

KING'S SERIES IN WOODWORK AND CARPENTRY

INSIDE FINISHING

BY

CHARLES A. KING

DIRECTOR OF MANUAL TRAINING

EASTERN HIGH SCHOOL, BAY CITY, MICHIGAN



LIBRARY OF
CALIFORNIA

NEW YORK .. CINCINNATI .. CHICAGO
AMERICAN BOOK COMPANY

TH 5606
K6

KING'S SERIES IN WOODWORK AND CARPENTRY

ELEMENTS OF WOODWORK

ELEMENTS OF CONSTRUCTION

CONSTRUCTIVE CARPENTRY

INSIDE FINISHING

HANDBOOK FOR TEACHERS

Price 10/-

**COPYRIGHT, 1912, BY
CHARLES A. KING.**

ENTERED AT STATIONERS' HALL, LONDON.

- W. P. I

TO THE
ASSOCIATION

PREFACE TO THE SERIES

THIS series consists of five volumes, four of which are intended as textbooks for pupils in manual-training, industrial, trade, technical, or normal schools. The fifth book of the series, the "Handbook in Woodwork and Carpentry," is for the use of teachers and of normal students who expect to teach the subjects treated in the other four volumes.

Of the pupils' volumes, the first two, "Elements of Woodwork" and "Elements of Construction," are adapted to the needs of students in manual-training schools, or in any institution in which elementary woodwork is taught, whether as purely educational handwork, or as preparatory to a high, or trade, school course in carpentry or vocational training.

The volumes "Constructive Carpentry" and "Inside Finishing" are planned with special reference to the students of technical, industrial, or trade schools, who have passed through the work of the first two volumes, or their equivalent. The subjects treated are those which will be of greatest value to both the prospective and the finished workman.

For the many teachers who are obliged to follow a required course, but who are allowed to introduce supplementary or optional models under certain conditions, and for others who have more liberty and are able to make such changes as they see fit, this series will be found perfectly adaptable, regardless of the grades taught. To accomplish this, the material has been arranged by topics, which may be used by the teacher irrespective of the sequence, as each topic has to the greatest extent possible been treated independently.

The author is indebted to Dr. George A. Hubbell, Ph.D., now President of the Lincoln Memorial University, for encouragement and advice in preparing for and planning the series, and to George R. Swain, Principal of the Eastern High School of Bay City, Michigan, for valuable aid in revising the manuscript.

Acknowledgment is due various educational and trade periodicals, and the publications of the United States Departments of Education and of Forestry, for the helpful suggestions that the author has gleaned from their pages.

The illustrations in this Series, with the exception of the photographs in "Elements of Woodwork" and "Elements of Construction," are from drawings made by the author.

BAY CITY, MICHIGAN.

CHARLES A. KING.

PREFACE TO INSIDE FINISHING

IN many places carpenters are classified as framers or outside men, and joiners or inside men; the subject matter treated in the following pages refers especially to the work of the latter, as it deals with the fitting up of the house to make it habitable after the framing, covering, and outside finishing have been completed. Certain aspects of carpentry of interest to the prospective contractor are also dealt with, and suggestions are offered which will be of assistance to him in placing his business upon a satisfactory basis.

In connection with this book, research, discussions, and the writing of essays on the various subjects presented should be required. The arithmetic includes many problems similar to those which the mechanic has to solve in his daily work, and a thorough drill upon these will add much to the equipment of the future workman.

TABLE OF CONTENTS

	PAGE
CHAPTER I. HEATING, VENTILATION, SANITATION, REFRIGERATORS. —	
1. Fireplaces and stoves; 2. Hot-air heating; 3. Steam and hot-water heating; 4. Steam heating; 5. Hot-water heating; 6. Ventilation; 7. Plumbing; 8. Sanitation; 9. Refrigerators; 10. Construction of an ice house	1
CHAPTER II. FLOOR LAYING, INSIDE FINISH. — 11. Floor laying; 12. Wood for finishing; 13. Casings; 14. Moldings; 15. Molding joints; 16. The dado; 17. Rake dado; 18. Soffits; 19. A splayed soffit; 20. Circular panel work; 21. Closets; 22. A drawer case; 23. A kitchen sink; 24. The bathroom; 25. Wood mantels, hardware	19
CHAPTER III. DOORS. — 26. Doors; 27. Stock sizes; 28. Selection; 29. Veneered doors; 30. The doorframes; 31. The doorframes of a brick house; 32. Setting doorframes; 33. Jointing; 34. Hanging a door; 35. Fitting locks; 36. The threshold	53
CHAPTER IV. WINDOW FRAMES AND SASH. — 37. Window frames; 38. Window sash; 39. Glazing sash; 40. Stock sizes of sash; 41. Fitting a sash; 42. Hotbed or skylight sash; 43. Store sash; 44. Blinds	69
CHAPTER V. STAIR BUILDING. — 45. Making measurements; 46. Laying out stairs; 47. Headroom; 48. Stringers; 49. Forms of stairs; 50. Stair posts; 51. Treads and risers; 52. Circular stair risers; 53. Handrails; 54. Balusters; 55. Handrailing	88
CHAPTER VI. PAINTING, HARDWARE. — 56. Painting; 57. Hardware	121
CHAPTER VII. ESTIMATING. — 58. Plans; 59. Location; 60. Method; 61. Excavations; 62. Stonework; 63. Brickwork; 64. Carpentry; 65. Roofing; 66. Joinery; 67. Plastering; 68. Hardware; 69. Painting; 70. Heating and plumbing; 71. Summarizing the estimates; 72. Stock bill; 73. The contractor	130

FIG.	PAGE
29. Joints of Door Jambs	58
30. Setting a Doorframe in Brickwork	58
31. A Fitted Door	60
32. Cutting in the Hinges	61
33. A. Loose-pin Butt ; B. Loose-joint Butt	62
34. Cupboard Hinges	63
35. A Rim Lock	63
36. A Mortise Lock	64
37. Placing the Striker or Latch Plate	64
38. Cutting down a Threshold	65
39. Window Frame with a Single Sill	69
40. Window Frame with a Subsill and Blind Stop	71
41. Window Frame for a Brick House ; a Box Frame	72
42. Stool and Sash with Drip	73
43. Sash Members	75
44. Mortised and Coped Joint	76
45. Meeting Rail Joint	76
46. The Strongest Form of Meeting Rail Joint	77
47. Section of a Glazed Sash	77
48. Bedding Glass	78
49. Setting Glass	78
50. Fitting Sash	81
51. Skylight Sash	83
52. Hotbed Glass Frames	84
53. Setting Glass in Store Windows	85
54. Method of Laying out a Stairway	89
55. Method of Turning the Angles of a Stairway	91
56. Laying out a Stringer	92
57. The Pitch Board	93
58. Intersection of Risers and Face Stringer	94
59. Fitting a Skirting Board ; Method 1	95
60. Fitting a Skirting Board ; Method 2	95
61. Fitting a Skirting Board ; Method 3	96
62. Construction of Buttress Stairs ; Method 1	97
63. Construction of Buttress Stairs ; Method 2	98

LIST OF ILLUSTRATIONS

xi

FIG.		PAGE
64.	Methods of Building Stringers	98
65.	Methods of Fastening the Tops of Stringers	99
66.	Dog-leg Stairs	100
67.	Intersection of Carriages and Risers with the Section Post	101
68.	Location of Stair Posts	101
69.	Laying out Stair Posts	103
70.	Construction of Treads and Risers	108
71.	A Method of Finishing the Ends of Treads and of Mitering a Riser and Face Scroll	109
72.	Methods of Making a Curved Riser	110
73.	Forms of Handrails	111
74.	Methods of Fastening Handrails to Posts	111
75.	Methods of Splicing Handrails	112
76.	Types of Balusters and Methods of Setting Them	113
77.	Handrailing	115
78.	Diagram	166
79.	Diagram	169

INSIDE FINISHING

CHAPTER I

HEATING, VENTILATION, SANITATION, REFRIGERATORS

1. **Fireplaces and stoves.** — (A.) The *heating of a building* is not a part of the work of a carpenter, but he should have some knowledge of the different methods of heating in common use.

Our forefathers used *fireplaces* for both heating and cooking, but as far as heating is concerned, they are unsatisfactory, as the room quickly cools off if the fire dies down. They are invaluable in the fall and spring, before and after it is necessary to heat the entire house, and as an auxiliary to the heating system during an extremely cold spell.

A fireplace furnishes a valuable means of ventilation, and thus adds much to the healthfulness of the house, besides imparting an air of cheerfulness. The center of the decorative scheme of a room is generally the fireplace and mantel.

(B.) *Stoves* are efficient as heaters, and may be regulated to radiate as much or as little heat as desired, within the capacity of the stove. They are inconvenient, and cause much dirt to be brought into the room.

2. **Hot-air heating.** — (A.) A system of *furnace heating* properly installed usually gives satisfaction, though there is an economical tendency to put in a furnace which is not quite large enough for extremely cold weather.

The furnace should be set low, and accordingly is often placed in a pit in the cellar, in order to give as much pitch to the conductor pipes as can be obtained, since a pipe with less rise than one inch to each foot in length is very apt to conduct heat unsatisfactorily, though the pipes leading to the upper floors of a building will give satisfaction with less pitch than those which heat the lower floor.

The furnace should be located very near the center of the system, but nearer the side of the house from which the prevailing cold winds come, to give as much pitch as possible to pipes running in that direction, which rarely conduct the heat as satisfactorily as others. These conductor pipes should be connected at the furnace upon the same level, or the highest pipes will take most of the heat and destroy the efficiency of the others. The conductor pipe leading to a room which is difficult to heat is sometimes placed above the others, but not unless it is very necessary.

(B.) A *cold air duct* of about half or two thirds of the capacity of all the conductor pipes it is to supply should connect the furnace chamber with the outside air, by means of which, pure air is heated before being used to heat the house. This cold air duct should be provided with a damper or slide, by which the air supply may be regulated; if the best results are desired, ducts should be taken from opposite sides of the house, as the direction of the wind often has considerable effect upon the efficiency of a furnace.

A register sometimes is placed in the floor or wall for the purpose of conducting impurities out of doors; this formerly was a common custom in the best houses, but is not used so much at the present time, as partly heated air is

wasted, and the expense of heating a house is increased. Instead of allowing this air to pass out of the house, it is usually conducted to the furnace chamber and reheated, and enough pure cold air allowed to enter the furnace chamber at the same time, to replace the vitiated air. From the standpoint of theory this is not desirable, but in an ordinary dwelling there are not enough impurities to make this method hygienically objectionable, as the opening of the doors and the crevices of the house will allow enough pure air to enter to make the air in the house suitable for use.

Since most of the impurities in the air are burned out by contact with the furnace drum, and since greater efficiency of the furnace is obtained at less cost, this method is being installed in nearly all of the best furnace-heated houses now in construction, and many are being remodeled to allow this system.

It is important that furnace pipes should be carefully wrapped in asbestos paper to retain the heat and to conform to insurance regulations; pipes which go in the partitions should be put in place before the house is lathed.

(C.) In a modern furnace, there is provision made for a *water pan* in the air chamber. The water becomes heated to a moderate temperature, so that moisture is given off by evaporation, and carried through the house by the movement of the heated air. Unless moisture is supplied, the air will be so dry that it not only is undesirable for breathing, but will cause the joints of the finish and of the furniture to open, the frame of the building to shrink so much that the plastering will crack, and the doors to warp and shrink so badly that they will not latch.

3. **Steam and hot-water heating.** — There are three methods of heating, by some one of which all steam or hot-water heating apparatus is operated.

(A.) The term *direct heating* is applied to the system in which heat radiates from coils of pipes or radiators directly into the room in which the appliance is located.

This method is used in places where little attention is paid to ventilation, though it should not be installed where there are to be many people, as the same air is simply heated over and over again.

(B.) The term *indirect heating* is applied to the system in which fresh air is heated by being passed through steam or hot-water radiators located outside of the room which is to be heated. Though not often so regarded, a hot-air furnace is an example of this system, as the outside air is heated before it is conducted into the room.

In this method of heating, a system of ventilation is frequently installed in connection with the steam or hot-water system, by which the impure and cold air is removed at the floor level, giving place to heated fresh air.

This method is sometimes applied by connecting the foul or cold air ducts with the heating coils, as described in furnace heating, and by allowing this partly heated air to be reheated more economically than if cold air were heated to the desired temperature. It is obvious that this system, which is in effect direct heating, is objectionable where many people have to breathe the same air over and over. This objection is to some extent removed by the introduction of a certain amount of fresh air to the heater to replace some of the vitiated air, as by the indirect method. (See the preceding page.)

(C.) The third method is known as the *direct-indirect*,

which, as its name implies, is a combination of the two above described.

In this system the radiator is placed in the room to be heated, and the air is reheated as often as it comes in contact with the radiator. To furnish a certain amount of fresh air, a duct is so located that air from the outside passes into the room through the radiator, replacing impure air which is removed through vents or foul-air ducts by natural or forced draft, the latter of which should be used if the most reliable results are wanted. This method is used a great deal in heating large halls, theaters, churches, etc., and gives quite satisfactory results, though the indirect method with a system of forced draft ventilation is generally considered the best device for heating large buildings; its expense, however, prevents its universal adoption.

The term direct, indirect, or direct-indirect, as applied to a radiator, refers to the relation of the radiator to the air supply and the room to be heated, and not to any peculiarity of construction or circulation of steam or hot water in the radiator itself.

4. Steam heating. — A *steam-heating* system may be installed after the house is built; this is often a great advantage, but as it is expensive to maintain for a small house, its principal use is to heat large buildings; in many locations, steam is conducted by the central-heating-plant system to all of the buildings within a radius of several hundred feet.

In places where steam power is generated, the radiators may be heated by exhaust steam, and the expense of heating, while the exhaust is being used, will be practically nothing. This is the method followed wherever possible. If direct steam is used, it is at a very low pressure, from

three to six pounds being sufficient to send the steam through the pipes and insure the return of the condensation to the boiler.

Steam radiators are connected by two systems; the *one-pipe system*, in which there is only one pipe to supply the steam, and to return the condensation to the boiler to be reheated, and the *two-pipe system*, in which each radiator or coil has a supply pipe, and a return to the main return pipe. Either system, if properly installed, will give satisfactory results. In neither system should there be pockets or sagging pipes in which the returning condensation may be trapped, as this will prevent the system from doing its work and, if the pipe should freeze, a new piece of pipe would have to be put in. In neither system should there be any part which cannot be drained.

5. Hot-water heating. — The initial cost of a system of *hot-water heating* is greater than that of a steam system, as more radiating surface is required, but it is less expensive in operation. As in steam heating, the pipes and radiators may be installed after the house is built. It is a very popular system for use in dwellings, as it requires but little care besides keeping the fires, which need less fuel than any other equivalent system.

In the pipes of this, as of the steam system, there should be no pockets or drops, and both should be so built that they can be thoroughly drained, to prevent freezing if the house is to be left vacant.

6. Ventilation. — *Ventilation* forms a part of most modern heating systems. Ventilation consists of more than furnishing a sufficient supply of fresh air; it should provide also for removing the air which has been breathed, or which has been polluted by coming in contact with unclean

bodies or clothing. An opening in the ceiling of a room is not satisfactory, if it is the only means of ventilation, as it allows a great deal of heat to escape. A ventilator of this sort should be used judiciously, especially in cold weather ; if a building or auditorium intended to accommodate large gatherings is constructed properly, the ceiling will be high enough to allow foul air to be well above the heads of the people, and the ventilator need not ordinarily be opened at times when the loss of heat would be a serious inconvenience.

The heat of an indirect system usually enters a room near the ceiling, and in its downward passage carries with it impurities and the most poisonous gases. These descend to the floor, and unless removed, will accumulate until the air is absolutely poisonous. To provide an easy exit for these gases, registers should be placed in the floor, or in the wall near the floor, through which the gases may be conducted out of doors by one of two methods, the *natural draft*, or the *forced draft*. The former allows gases to follow their own inclination, and while ventilators are made which, by various devices, accelerate the movement, the efficiency of the system depends, to a great extent, upon the condition of the outside atmosphere, which, if dead and heavy, checks the air current.

The forced draft is independent of the atmospheric conditions, and a current of air may always be maintained, as the draft is caused by a fan driven at a high rate of speed, which draws the impure air from the inside of the building, and forces it out of doors. This air, of course, is replaced by pure heated air, or in warm weather by artificially cooled air. Thus the air is kept continually in motion.

The contractor in building a house generally will sublet

the heating and ventilating, as this work, in order to insure satisfactory results, should be planned and installed by men who have made it a study and who are familiar with all the appliances and methods which will assist in making it efficient and satisfactory.

7. Plumbing. — It is the usual custom that the carpenter should do all of the cutting necessary to allow the plumber to lay pipes and to set his work properly. The soil pipes and all others which are to be laid in the walls or floors should be in place before the house is lathed or the floors laid.

The carpenter should not attempt to say whether the work is properly done or not unless he has had considerable experience with plumbers' work; if he is responsible for the work done upon a house for which there is no architect, he should engage some competent person to inspect the work thoroughly before it is covered. A guarantee from a responsible plumber is often accepted. In most cities where there are sewer and water systems, there is an official inspector of plumbing, who should be given every opportunity to look over work, for if a faulty place is discovered after the house is finished, considerable expense and annoyance may be caused in making it right.

That part of the work which is out of sight is most important; no elaborate fittings can compensate for imperfect plumbing in the wall or under the floor.

8. Sanitation. — (A.) The disposal of sewage is always one of the gravest problems to consider in the development of a community. The cities upon or near the seacoast have the nearest to ideal conditions for disposing of their sewage, as it is simply emptied into the ocean or one of its tributaries, generally by gravitation, and the action of the

tides will carry the matter out to sea, where it is scattered by the ocean currents, and in no case is there any danger of the water supply being affected, as salt water is not used for domestic purposes.

Any lake or river, no matter how large, if it continually receives sewage in any quantity, will eventually be contaminated.

It is not the purpose of this book to discuss the efficiency of the many various systems of disposing of the sewage of inland cities, so we will consider merely the aspects of sanitation with which the carpenter has to deal.

(B.) The *privy*, which is in common use in rural districts, is prohibited by law in modern towns and cities, where the houses are close together and where a sewer is provided. Even where there is plenty of room, care must be used that the privy is not placed where there is the slightest danger of affecting the water supply, or where it will drain into a brook from which cattle have to drink. It should be located always below the water supply if possible. A privy is usually very obnoxious in warm weather, even at some distance from the house, but it may be made inoffensive by scattering, in the vault, dry earth, which will prevent odors from spreading.

Chamber slops should not be thrown into a privy, but instead should be thrown upon the grass, or in any place where the sun can do its work of purifying.

(C.) Where there is no sewerage system and privies are in common use, the *dry earth closet* is a simple and efficient method of dealing with this problem. The closet should be light, well ventilated, and fly-proof. The equipment may consist of a box of dry earth or road dust, to be used as often as the closet is, or it may be an elaborate

arrangement, in which the earth is thrown in above and handled with a slide, as it is needed. A closet of this sort may be built as close to the house as desired, and if properly cared for, will never be objectionable.

If this form of closet is used, there should be provided a place, perfectly dry and large enough to contain a sufficient quantity of dry earth to care for the privy during rainy weather and the winter months. This should be kept full of road dust, which is well suited for this purpose. The receptacle should be a well made, water-tight, movable box with handles, so it may be easily emptied, though an ordinary vault may be used.

(D.) *Water-closets* are not possible in all localities, not only on account of the absence of a sewerage system, but because the soil is not adaptable to the construction of a cesspool, which is simply a deep hole, loosely walled to keep the earth from caving in, but which will allow the contents to seep away through the soil. This is connected by a drain to the house, and is the means of disposing of sewage and household waste in many places where there is a sandy subsoil and where there is no danger of contaminating the water supply. It is not considered a system suitable for general use, even in isolated places, as a well a long distance away may be affected; nevertheless, it is used in many places where there is a deep sandy soil.

A method of disposing of sewage, known as the sub-surface system, is sometimes used in localities where there are good natural drainage facilities. In this system, the sewage or other household waste is conducted to tanks in which the solid matter is precipitated, and the liquid is distributed through a series of drains laid under the surface of the ground, from which it finds its way to some natural

watercourse. This is a complex matter to discuss, and we shall not do more than mention it.

Another method known as the "Septic" consists of beds of sand located in some isolated place, lower than the area which is drained, in which the sewage is exposed to the action of the sun and the air. This method is being used with satisfactory results in small inland communities and by institutions.

(E.) *Sink drains* should carry as far as possible from the house, and should have as much pitch as can be obtained, not less than 1' in a run of 40', for a 4" drain tile, which is as small as should be used. Under the sink there always should be a trap made perfectly tight with solder. If more than a sink enters the drain, the work of connecting should be done by a plumber, for if improperly done, the effects may be very serious.

A drain should have as few bends as possible in it; the bottom should be laid straight, or in straight sections, regardless of the surface of the ground, and low enough to be well below the frost line.

The end of the drain should empty in a sandy place upon a side hill if possible, as high as the nature of the ground will allow, or otherwise the outlet will freeze in winter and possibly destroy several feet of the end of the drain.

In rural districts the drain often empties upon the top of the ground at some distance from the house, and for ordinary conditions in the country there is little to criticize in this, provided there is no danger of affecting the water supply, as the sun is a great purifier. The drain tile should be laid in cement, with perfectly tight joints, and without low places, or rough cement on the inside of the pipes, to catch the matter from the sink.

9. **Refrigerators.**—(A.) *Refrigeration* upon a large scale has become the work of the scientist and the engineer, and we shall not discuss the problem, as it includes very little in which the carpenter would be interested, but we will discuss the construction of an ice refrigerator suitable for family use, or for use in a meat market, or wherever one is needed.

(B.) A *refrigerator* operates upon the principle that air of a low temperature will descend, and that of a high temperature will rise if both are confined in the same compartment.

To make an efficient refrigerator the walls should be airtight, and the doors fitted closely and forced tightly into their places. The walls should be made of two or more thicknesses of ceiling, with air spaces dead between in which the air is perfectly dead. In order to insure this, there must be studding every 18" or 24", as the stock will work to the best advantage. The ceiling in every case should be laid upon dressed studding of an even thickness, say $1\frac{3}{4}'' \times 2\frac{3}{4}''$, and a good grade of sheathing paper laid between the stud and the ceiling.

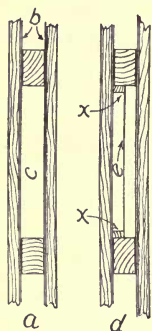

FIG. 1.—REFRIGERATOR WALLS.

Figure 1 shows two methods of building the walls of a refrigerator. At *a* is shown the method of constructing the wall. Ceiling is laid upon the studding or framework of the refrigerator, with sheathing paper (*b*) between it and the studding, leaving a dead air space (*c*) between the two layers of sheathing paper; this is an efficient means of preventing the inside of a refrigerator from being affected by the outside temperature. The space *c* may be filled

with shavings, which will settle vertically unless filled under pressure. This is often done, but it accomplishes little, or no more than does a dead air space.

At *d*, a piece of sheathing paper (*e*) is tacked tightly upon the small pieces of wood (*x*) which surround each space between the studs; this makes an extra air space to help make the walls impenetrable.

The walls of refrigerators are sometimes insulated with hair felting, or with mineral wool, which, if kept dry, will make an excellent wall to resist the passage of air from the inside or outside of the refrigerator.

For convenience, the ice door should open from the front of the refrigerator and be of a size to admit as large a piece of ice as possible; if the door is in the top, the ice will not melt so rapidly.

The doors and jambs should be made and fitted by some method similar to that shown in Fig. 2, by making as

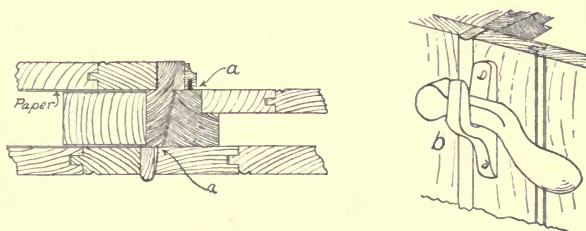

FIG. 2.—REFRIGERATOR DOOR AND LOCK.

nearly an air-tight joint as possible at *a* by means of a felt or rubber weather strip, and by forcing the door into its place by a lever lock (*b*), placed upon the outside of the door. There are several kinds upon the market, but the one illustrated at *b* is efficient and economical.

Figure 3 shows the construction of an ice chamber, which should occupy from one fifth to one third of the cubical contents of the refrigerator. At *b* is seen the ice rack, the top of which should be set level. The floor of the ice chamber (*c*) should be set

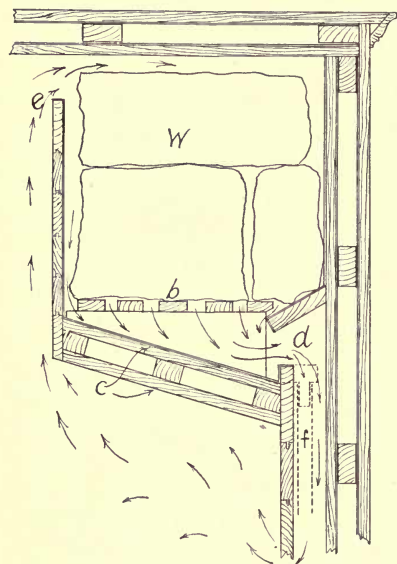

FIG. 3.—THE ICE CHAMBER.

at a pitch so that the cold air will have plenty of room to find its way to the cold air duct (*d*) through which it is carried some distance below the bottom of the ice floor. As the air absorbs gases and heat from the foods, its temperature rises, and it passes through the warm air flue (*e*) and into the ice chamber (*w*) where the gases condense upon the ice and pass off in water form through the waste pipe (*f*) which has a trap at the end

of it, to prevent the escape of cold air. The ice chamber should be lined with galvanized iron, which is very durable, but in the lower-priced refrigerators, zinc is much used.

This is, in substance, the method of the construction and operation of ice refrigerators. Other things being equal, the one which gives the freest circulation of air is the one which will give the best results, both in economy of ice and in the preservation of its contents.

In building a refrigerator, the workman cannot be too

careful in making all joints as nearly air-tight as possible. It is the poorest economy to save on the price of the refrigerator by omitting anything which will tend to make it air proof, as the additional cost of the ice unnecessarily used will soon be more than the extra cost of building the refrigerator properly.

10. **Construction of an ice house.**—Figure 4 indicates the method by which an ice house may be constructed.

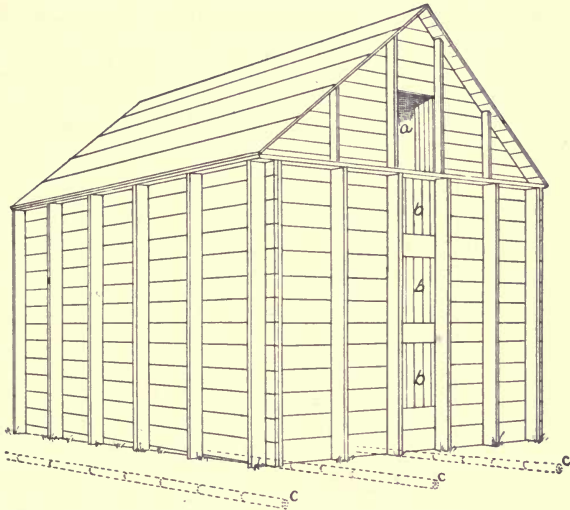

FIG. 4. — ICE HOUSE CONSTRUCTION.

The ground upon which the building is to stand should be well drained with a tile drain, as at *c*, not less than 12'' below the surface, and in rows not more than 6' apart. The site should be so graded that no surface water will run over the floor after the building is completed. A slope in the ground upon which the house stands will assist in the drainage.

The house should be large enough to allow at least one foot of sawdust, shavings, or hay under and on each side of the desired quantity of ice, which should be packed in a solid mass, with nothing between the cakes. Hay is preferred for the outside packing, as it may be handled more easily than either sawdust or shavings.

It is the custom of many, after the ice house is filled, to deluge the mass of ice with water, thus making nearly a compact mass, and preventing the circulation of air as much as possible. After the house is filled, the ice should be covered with at least a foot of hay.

The building should be covered with a tight roof, and the gables boarded up, with a door (*a*) at each end for ventilation. These should never be entirely closed during warm weather. Doors for convenience in filling and emptying should be made at *b, b, b*. In large ice houses, the filling and emptying is done by machinery and inclined planes.

SUGGESTIVE EXERCISES

1. Is a fireplace satisfactory for heating a room? For what is it chiefly valuable? What are the objections to stoves as a method of heating?

2. What is the general tendency in installing a furnace? At what level should a furnace be set? How is this sometimes done? Why is this necessary? What is the least pitch or rise a conductor pipe should have? Which pipes generally have less pitch? At what point should a furnace be located in regard to the heating system of the house? How should the prevailing winds affect the location of the furnace? Why? What should be the capacity of a cold air duct? How is the supply of cold air regulated? How is the cool air often taken from the house and used again? Is this a perfectly hygienic arrangement? Why is it a satisfactory method for dwelling houses? How should the conductor pipes be treated to retain the heat? When should the pipes be put in

the partitions? What provision is made to prevent the air from being too dry? What are the objections to very dry air?

3. What is meant by direct heating? Describe it. In what kinds of places is it used? For what places is it unfit? What is meant by indirect heating? Describe it. How is this method of heating used in connection with a ventilating system? What is the objection to conducting the partly heated air back to the heater? What is the advantage? How is it made less objectionable? What is meant by direct-indirect heating? Describe it. In what sort of places is this method of heating used? Which is considered the best of the three methods?

4. What is one advantage of a steam-heating system for an old house? In what sort of buildings is it generally used? Why is it undesirable for a small house? What methods of radiating may be used? What is generally the heating medium for the indirect method? What is the advantage of a steam-power plant as regards heating? What is the common pressure of a direct steam-heating system? What are the two systems of connecting radiators? What is the objection to sagging pipes?

5. Which is the more expensive system to install, steam or hot-water? Which is the more popular for dwellings? Why?

6. What are the requirements of a complete system of ventilation? Why should a room to contain a large number of people be high? Where is the heat of an indirect system usually conducted into a room? How are the poisonous gases removed from the room? In what part of the room do these gases gather? What are the two methods employed in removing vitiated air from the room? Describe the natural draft. Describe the forced draft. Compare them.

7. In what way is it customary for the carpenter to assist the plumber? When should the pipes in the walls be laid? What should the carpenter do in regard to the inspection of the plumbing? What is the most important part of the plumbing?

8. What cities have the best system of sewerage? What are the advantages to these cities? What is the objection to discharging sewage into a lake or river? Where should a privy be located? How may a privy be made inoffensive? How should chamber slops be disposed of? Describe the kind of house necessary for an efficient dry earth closet. Describe an earth closet receptacle. Describe a

cesspool system of sewerage. What is the objection to this method of disposing of sewage? What kind of soil is best for a cesspool? Given an outline of the subsurface drainage system. What should be the pitch of a sink drain? What should be its size? How should the drain tile be laid? Should the end of the drain rest upon the ground? Why?

9. What is the principle of the operation of a refrigerator? Describe the construction of the walls of a refrigerator. What is a necessary condition of the walls? How should the doors be fitted in order to be as nearly air-tight as possible? Describe the interior construction of a refrigerator. Describe the circulation of air in a refrigerator. Compare the different locations of the ice door. What is poor economy in building a refrigerator?

10. How should the ground under an ice house be treated? How should surface water be kept out? Describe the construction of an ice house. How much sawdust should surround the ice? How should ice be packed in an ice house? How should an ice house be ventilated?

CHAPTER II

FLOOR LAYING, INSIDE FINISH

11. **Floor laying.** — (A.) Floor laying is a branch of carpentry which, in some localities, is done almost entirely by specialists who can do a far greater amount than can the all-round man. Figure 5 shows the kinds of floors in most common use, the *matched* (a), and the *square-edged* (b). The former of these always should be blind nailed; that is, the nails should be driven into the edge as shown at c, with a nail set; the entire floor may then be laid with no nail heads showing.

This is the method by which the best floors are laid, though it is slower than the square-edged method, since the floor has to be laid one board at a time. Also it is a more expensive floor, as considerable lumber is used in making the tongue for matching the boards.

A piece of $3\frac{1}{2}$ " matched flooring or ceiling is made from a board $3\frac{1}{2}$ " wide, but its covering surface is only 3", as shown at a, Fig. 6. On account of the tendency of the grain of wood to straighten itself in drying, boards will frequently have "kinks" or short bends in them, due

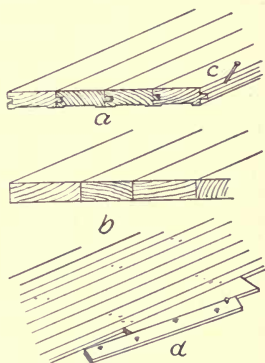

FIG. 5. — MATCHED AND SQUARE-EDGED FLOORING.

to cross-grained places; in order to straighten boards of this sort, it is often necessary, in matching them, to make their faces $\frac{3}{4}$ " or 1" less in width instead of only $\frac{1}{2}$ ", and $\frac{1}{4}$ " less in thickness instead of $\frac{1}{8}$ ", than the sawed

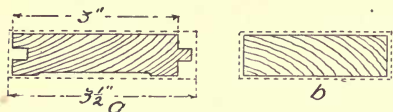

FIG. 6.—WASTE IN FLOORING.

dimensions, indicated in Fig. 6, which were based upon a straight board. Therefore it is customary to allow one quarter or one third of the floor area for waste in matching and in cutting out imperfections; while for a square-edged floor an allowance of one fifth or one fourth is sufficient, as there is no waste in matching. (See *b*, Fig. 6.)

Usually it is not necessary that matched flooring should be nailed at every joist; an 8d floor nail every second or third joist is sufficient for narrow flooring; for wide material the nailings may have to be closer to hold the floor down properly. The best grades of factory matched flooring are usually bored along the edge to allow nails to be driven without splitting the piece. If these holes do not come over a joist, the nails will generally hold well enough if driven into the under floor only, as they enter the wood at such an angle.

For a very nice floor it may be necessary to smooth, scrape, and sandpaper the boards after they are laid, though if the flooring has been well made at the mill, it will be enough for common work to smooth the few joints which may not have come down perfectly.

If paper is to be laid under the wearing floor, it should be laid from the side from which the flooring is laid, or else at right angles, so that the edges of the paper will not curl up and prevent the boards from coming to a joint.*

If a floor is to have a natural finish, the carpenter always should select wood of the same color. In no other place is thoroughly seasoned stock more necessary.

It is always best to lay a floor with as narrow boards as possible, as the shrinking effect of seasoning is thereby minimized; if wide boards are used, the cracks will be more open, and therefore more noticeable.

In laying matched flooring, much depends in getting a straight start. If the wearing floor is laid upon an under-

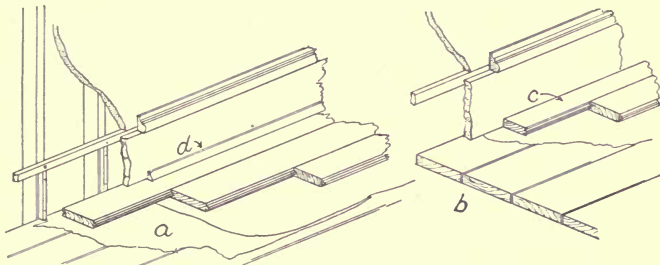

FIG. 7.—LAYING THE FIRST PIECE OF FLOORING.

floor, which is covered with sheathing paper, and if the base is cut down on top of it, as at *a*, Fig. 7, this is an easy thing to do, as the first two or three pieces may be nailed perfectly straight; but, if the base has been put on, as in *b*, the starting piece (*c*) should be carefully scribed to the base, the grooved edge being the one fitted. A straight piece must be selected for the first because a crooked one would make trouble in laying the next few boards. One with a bruised, grooved edge should be selected if there is such, as the bruise may be cut off in scribing, while it might destroy the piece for use elsewhere in the floor.

If a quarter round, or shoe strip is to be used, as at *d*,

Fig. 7, this fitting may be dispensed with, and the starting piece laid straight. A strip of any kind at the joint between the base and the floor always seems to hide a bad joint, and it is rarely used upon the best work.

If a floor is to be hand smoothed, time may be saved by using care in selecting the grain, and by laying as many pieces as possible of the same grain together, then several more of grain running in the opposite direction. This can be done only in a general way, but it is good practice.

(B.) A square-edged floor should not be laid one board at a time, but a "bay," two or three feet in width, of the floor boards should be cut to the same length, and wedged so tightly that each joint will be perfect, as shown at *d*, Fig. 5. Enough nails are driven to hold the boards in place while the process is repeated until the entire floor is cut down; in doing this, the different bays of flooring should be cut to different lengths, breaking joints with the adjoining bay at least 32", or the distance between centers of two joists; this will prevent a straight joint from extending across the floor and will add to the stiffness of the building. It is best to select boards for each bay of the same aggregate width as the boards they join endways. Any small spaces left open on account of the material not exactly fitting can be filled in after the floor is nailed. In heavy buildings, it is quite a common custom to lay the flooring diagonally, to add rigidity to the structure.

When the boards are all cut and laid, marks should be made with a chalk line or pencil, by a straightedge, to indicate the exact location of the joists as a guide in driving nails. The young workman must learn to keep his left hand full of nails and one nail in the wood all of the time; with a little practice, one at a time may be picked

out by the thumb and middle finger, and held for the first blow of the hammer.

12. Wood for finishing. — In selecting the inside finish for a house, care should be used to sort the different colors as much as possible; though the same grade and the same kind of wood may be used, some of it will be darker or lighter than the rest. The dark wood should be used in certain rooms, and the light wood in others.

All of the exposed finish of a room should be of the same wood, though the doors upon very good work are often, and upon common work are generally, of a wood different from that of the rest of the room. Almost any kind of wood may be used for inside finish, provided the desired dimensions can be obtained and the appearance is satisfactory, since very little wear comes upon it. Certain kinds of woods, as spruce, gum, and buckeye, do not hold their shape well unless very strongly fastened. Basswood is used to some extent, but it shrinks and swells considerably unless it has been well seasoned.

The woods commonly used are the pines, oaks, walnuts, whitewood, or poplar, red birch, black gum, ash, chestnut, cherry, cypress, redwood, maple, sycamore, and a few other woods, the use of which is largely local. Besides these, imported woods are used to some extent, chief among them being mahogany.

The best material should be selected, which should in every instance be thoroughly kiln dried, especially for mitered finish.

13. Casings. — (A.) The tops of all the openings of a room should be on the same line. This often is accomplished by putting a transom in over the doors, but the rule is disregarded as much as any other rule in carpentry,

even upon the best work, as it affects only the appearance of the room and in no way the comfort of the house.

(B.) Figure 8 shows three styles of finish for the casings of doors and of window frames. The *mitered* (*a*) is the style generally favored upon the best class of work. The

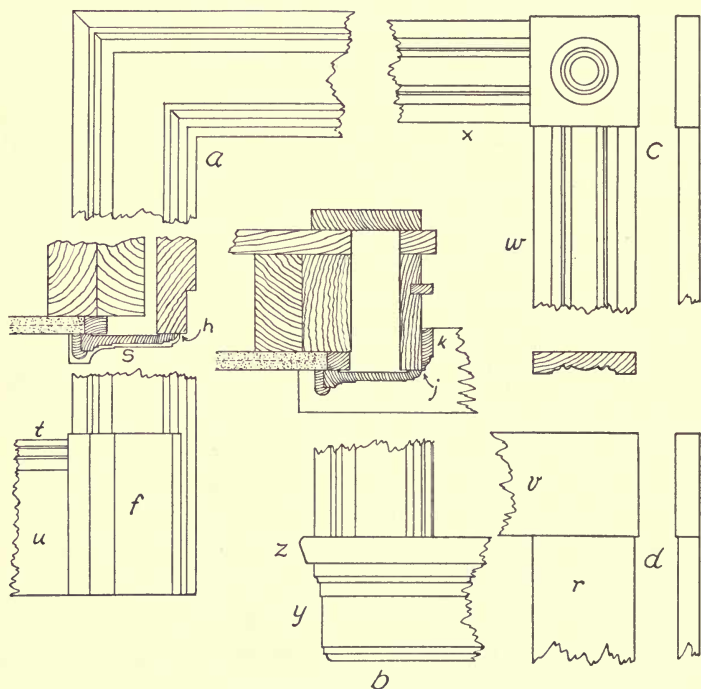

FIG. 8.—TYPES OF FINISH.

window casing and stool finish are shown at *b*. The end of the stool at *z*, and of the apron at *y*, should be mitered, or returned upon themselves; this applies to all forms of finish.

The *corner block* finish (*c*) is used commonly, as it is

more easily put in place than the mitered finish and more ornamental than the plain finish, shown at *d*; if the material shrinks or swells, the defect is not so evident as in the mitered finish. The corner block should be $\frac{1}{8}$ " thicker, and $\frac{1}{4}$ " longer and wider than the side casing or architrave (*w*), and the header (*x*).

The *plain* finish (*d*) is used in many places where it is difficult to obtain moldings, though unimportant rooms of good buildings are often finished in this style. The header or lintel (*v*) should be $\frac{1}{8}$ " thicker than the side casing (*r*) and should project equally at each end.

A *plinth* (*f*) 9" or 10" high should be used to finish the bottoms of the side casings of all forms of door finish, to give a place against which the baseboard (*u*) and molding (*t*) may stop, if the latter is separate from the baseboard. For economy the plinth is often omitted, and the base and molding stopped against the architrave or side casing. The plinth may be of a straight piece, but upon the best work it conforms to the shape of the casing, as at *s*.

If a plinth projects more than $\frac{1}{4}$ " beyond the face of the baseboard, it is a good plan to cut the front corner of the bottom end off about $\frac{3}{16}$ " from the floor, and back to the line of the base, to admit a carpet, instead of cutting it, or leaving a bunch where it comes against the plinth.

Door casings always should be set back to show $\frac{5}{16}$ " or $\frac{3}{8}$ ", as shown at *h*, Fig. 8; it is best never to finish flush. The fillet or corner thus left adds to the appearance of the work, for, if the casing were made perfectly flush with the door jamb, the slightest difference would be noticed. It also allows the latch of the lock to swing clear of the finish upon which it otherwise might make an ugly scratch. An exception to this rule is in putting the finish around win-

dows, where the edge of the casing should be flush with the inside of the pulley style, as shown at *j*, Fig. 8; the stop bead (*k*) hides the joint.

Casings never should be spliced, for in every instance an unsatisfactory job results, as the joint is certain to open or start if the wood shrinks or swells.

In putting up any kind of trim or standing finish, the workman will realize that it pays to be sure that the frames are set square and plumb, and that the ends of the casings are cut perfectly square and true both ways, and fastened exactly to their places.

If every piece is set accurately, the work of finishing is greatly reduced, as upon common work it is usually satisfactory to make a joint without planing.

(C.) In putting on the *corner block*, as in many other things which vary in different localities, it usually is expedient to follow the local custom. It should be put on with the grain running the same way as the header, of which it is a part. Generally it is the custom to put it on so that it is a part of the side casing; the only advantage of this is that the end wood does not show.

Again, no workman should cut the header of a plain door casing between the side casings, as that would give the opening an appearance of weakness which should be avoided, even where strength is unnecessary. Also, if the grain of the block is set vertically, the shrinking is apt to open the joint between it and the header, while if the grain of the block runs horizontally, the open joint will come between the block and the side casing, where it is less conspicuous.

14. Moldings. — (A.) Moldings are indispensable to the carpenter in putting the finishing touches upon any piece

of work. It is obvious that a molding which is intended to be used in a certain place might be entirely unsuitable for use elsewhere, for instance: the band molding, *b* of Fig. 9, would be entirely out of place if used instead of the

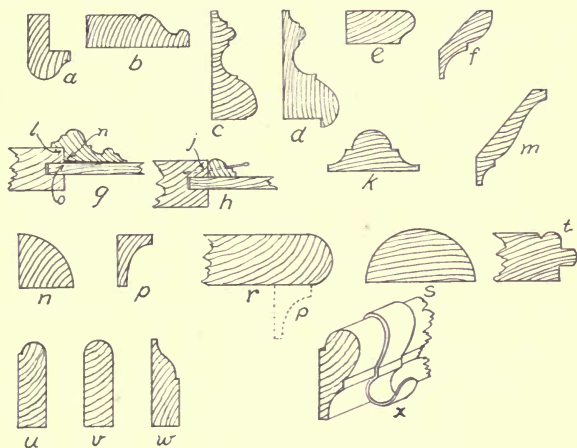

FIG. 9.—MOLDINGS.

cornice or crown molding which is shown at *m*. Thus it will be seen that the contour of the molding is not the important consideration, but its relation to, and the shape of the other surfaces of, the piece upon which it is molded. Lumber dealers keep in stock the standard forms of moldings, among which may be found types which are suitable for every purpose for which moldings are used upon buildings.

Those in most common use are shown in Fig. 9. The *band molding* (*a*) is used for the finishing member on the outside of a mitered casing; *b* is used sometimes for a band molding to form a rabbet upon a window frame, against which the siding is cut, to form a very tight joint.

The *base molding* (*c*) is nailed into the angle formed by the baseboard and the plastered wall, and the *lip molding*

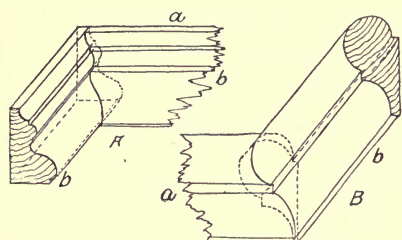

FIG. 10.—COPED JOINTS OF BASE AND PICTURE MOLDINGS.

(*d*) is for the same purpose, though rarely used. The molding should be nailed to the top of the baseboard, and not to the wall, as otherwise the shrinking of the baseboard will open the joint between it and the molding.

The outside corners of the base molding should be mitered, and the inside corners coped, as at *A*, Fig. 10.

The *cap molding* (*e*) finishes the top of a dado, or some such place.

The *bed mold* (*f*) is used to fill a corner or as part of a large cornice. In cutting the miters upon this type, the

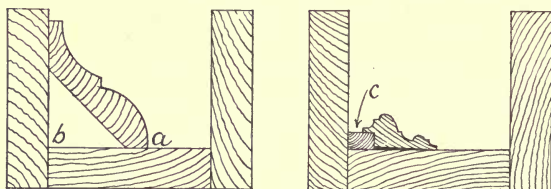

FIG. 11.—CUTTING THE MITER OF CROWN OR SPRUNG MOLDINGS.

molding should be held in the miter box as shown in Fig. 11, using care that the edge (*a*) is, throughout, the same distance from the back of the box (*b*).

Panel moldings are raised, as shown at *g*, Fig. 9, or sunk, as shown at *h*, and nailed to the frame of the panel work, as shown at *j*; if nailed to the panel, which may shrink, the molding would be pulled off the rails, making an

unsightly place upon the face of the panel work, while if properly done, the panel will shrink independently of the frame or molding.

The distance between the back (n) of the lip molding, and the under side of the lip (l) should be $\frac{1}{32}$ "', or less, smaller than the panel "sinkage," or the distance between the face of the panel work (l) and the face of the panel (o). This will allow the lip of the molding to fit closely against the face of the panel work, and will compensate for any slight inaccuracy. In mitering a lip molding, a small piece the size of the sinkage of the panel (l, o , Fig. 9) should be used as shown at c , Fig. 11, to allow the molding to be sawed at just the angle at which it finally lies.

A panel sometimes is laid out upon a flat surface by means of an *astragal molding*, shown at k , Fig. 9; it is used also to cover an open joint in a flat surface, and is valuable for a variety of uses.

The *crown molding* or *sprung molding* (m) is used as the highest or crown member of a cornice. Moldings of this type are suitable for the cornices of cases of shelves, closets, etc., and should be cut in a miter box as shown at a, b , Fig. 11.

The *quarter round* (n) is used, especially upon the cheapest work, to cover the joint in a corner, if the pieces which form the angle do not come together. It also is used as in Fig. 12, to put up partitions; one piece (a) is laid first and the ceiling partition (b) nailed against it; the quarter round (c) is afterwards nailed into the corner to cover the joint.

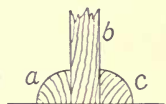

FIG. 12. — USE OF THE QUARTER ROUND.

The *scotia* or *cove* (p , Fig. 9) is used for purposes similar to those of the quarter round, and with other small

moldings for the purpose of building up large cornices. It is also placed under the nosing of a stair tread, as at *r*, under a dado cap, or wherever a finish under a cap or a molding is needed.

The *nosing* (*r*) is generally the edge finish of a stair tread, to round the edge of a board, a cap, or for similar purposes.

The *half round* (*s*) is applicable to many of the same purposes as the astragal. The *bead*, shown at *t*, is used upon ceiling, and wherever it is necessary to hide a joint. *Stop beads* (*u*) are used upon window frames to hold the lower sash in place; they are not confined to that design, as they may be shaped like *v*, or *w*, or any other desirable form.

Room or *picture molding*, as shown at *x*, Fig. 9, is fitted around a room near the ceiling, forming the lower edge of the frieze, or border. Its use is to support picture hooks, as shown. Its outside angles should be mitered, but the inside angles should be coped, as shown at *B*, Fig. 10.

(B.) Most of the moldings above described are mitered at both the inside and outside corners, except the base

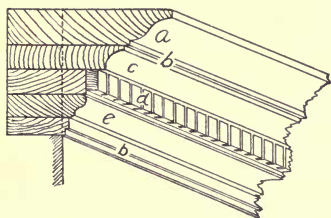

FIG. 13.—A BUILT-UP CORNICE.

They are made of *ogees* (*a*), *fillets* (*b*), *hollows* (*c*), *dentils* (*d*), and *quirks* (*e*). Different combinations of these details will furnish a great variety of larger moldings. They may be made of narrow pieces and fastened to the face of the work if desired, as indicated by the dotted line.

moldings, the room moldings, and other small moldings which should be coped at the inside angles, as described above, and shown in Fig. 10.

(C.) Specially designed cornices are frequently built up, as shown in Fig. 13.

They are frequently built up, as shown in Fig. 13. They

(D.) Nearly all of these moldings are modeled from those used by the architects and builders of the temples and public buildings which the Greeks and Romans erected.

There are eight distinct types of these moldings capable of great variation without losing their distinctive form. These forms are shown in Fig. 14; at *a* is seen the *ovolo* or *echinus*, which is the parent of the quarter round; at *b* the *talon* and *quirk*, or *bird's beak* molding, which should be used where it seems to support something as the shape suggests; at *c* the *cyma recta*; at *d* the *cyma reversa* or *ogee* moldings;

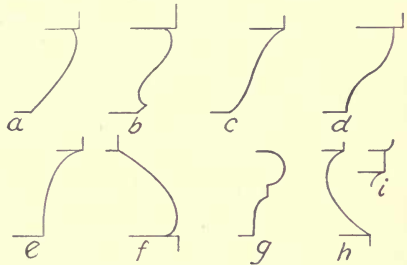

FIG. 14.—CLASSIC MOLDINGS.

at *e* the *cavetto*, *hollow*, or *cove*. The last three appear weak and should be used where they will seem to support no weight, as the upper member of a cornice, for instance.

The *torus* (*f*) (*bead*, *round*, or *thumb* molding) and the *astragal* (*g*) should appear to go around, as if to bind together. The *scotia* (*h*) and the *fillet* (*i*) are used as intermediates, to separate one member of a compound molding from another, and to give variety to a large cornice, or to form a break in a wide, flat surface.

The *ovolo* and the *talon* generally should be located above, and the *scotia* below, the eye.

The contour of moldings of the best periods of architecture is elliptical, not round, and in making and designing moldings, the workman should always strive for a graceful elliptical curve, instead of an arc of a circle.

A comparison of the two forms will show the difference in appearance.

In general, important moldings above the line of the eye extend upwards, and those below the eye extend downwards, from the vertical plane at an angle of about 45° , so that no important member of the molding will be out of the line of vision.

(E.) A *baseboard* is usually 8" wide, and should be well seasoned; it should not be put on until the plastering is thoroughly dry, or it will curl off, the moisture in the plastering swelling the back of the board, while the front remains dry.

When a single floor is laid, the baseboard is fitted upon the top of the floor boards, and a quarter round or shoe strip similar to *n* or *w* of Fig. 9 is nailed on to cover the joint, as at *d*, Fig. 7.

If the shoe strip is nailed to the baseboard, the shrinkage of the floor and baseboard will show a crack under the shoe strip, but if it is nailed to the floor, the shoe strip will follow the floor, and move with it, thus showing no joint.

If it is desired to dispense with the shoe strip, the baseboard should be nailed to the wall after the under floor is laid, and the wearing, or top floor, fitted to the baseboard, as at *c*, Fig. 7. Care should be used in fitting the ends of the flooring to the baseboard, for if one floor board is forced too much, it will push the base away from the one which was laid before it.

In cutting the baseboard down, the outside corners are mitered, and the inside corners cut square and butted upon common work; but upon the best class of work they should be housed, as shown at *a*, Fig. 15, to insure that the seasoning and settling of the building will not open the joint.

If it is necessary to splice moldings, the joint should be made in the least conspicuous place; to make the fewest possible splices, the long pieces should be fitted first. These splices may be made with either a butt or a miter joint, the latter of which is preferred by many workmen.

(F.) The quality of the work done with moldings depends to a great extent upon the condition of the

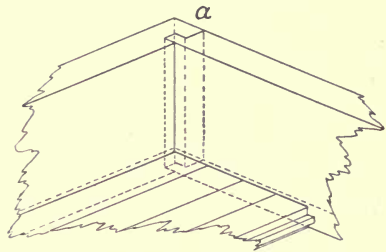

FIG. 15.—HOUSING CORNERS OF BASEBOARDS.

moldings used, and the selection of the material from which they are made. The lumber should be straight and straight-grained, and kept lying straight. After the moldings are “stuck,” that is, made, they must be handled with great care, or the corners and fillets will be bruised. One of the earmarks of a good workman is that he always leaves square corners; no rough, or “spalled” (rubbed), or broken edges should be permitted, but all corners and angles should be perfectly smooth and accurate.

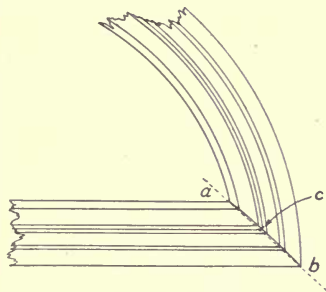

FIG. 16.—JOINTING A STRAIGHT AND A CURVED MOLDING.

15. **Molding joints.**—The curve of the joint *between a straight and circling piece* of molding may be found by the intersection method: place the moldings in their exact relation to each other, and mark the extreme points (*a, b*, Fig. 16). To ascertain *c* by another method than the

“cut and try,” lay out the moldings upon a board with a pencil, indicating a center line of each piece, and their intersection as *c*. The arc of a circle drawn through *a, b, c*, will give the sweep of the joint. Draw the chord of the arc of the joint as indicated by the dotted line, and measure the distance of its altitude at *c*; this must be transferred to each piece which is to form the joint. Upon a large molding, it may be easier to find the sweep by the well-known problem of constructing a circle from three given points.

16. The dado. — (A.) Woodworking machinery has made the construction of panel work, similar to the types indicated in Fig. 17, a simple matter. A dado of matched or beaded ceiling may be easily and economically made, and is often used in places where a more expensive dado is unnecessary. A ceiling dado is made upon the work, but paneled dado is usually made in a shop which has all of the appliances necessary for doing the work economically and well.

The measurements for dado should be taken at the building after the partitions are set, and it is possible to locate accurately all the openings and angles.

The different types of panel work, the names of their members, and the methods of construction in common use are illustrated in Fig. 17. At *a* is shown a plain panel, and at *b* a raised panel; either type may be used upon the cheapest or the best work, depending upon the effect desired. The grooves for the panels in the different members of the frame are usually $\frac{9}{16}$ " deep to accommodate $\frac{1}{2}$ " of the panel and to allow for any possible swelling.

The stiles (*c*) should be grooved, usually upon one edge only, to receive the panels and the ends of the rails *d, e, f*.

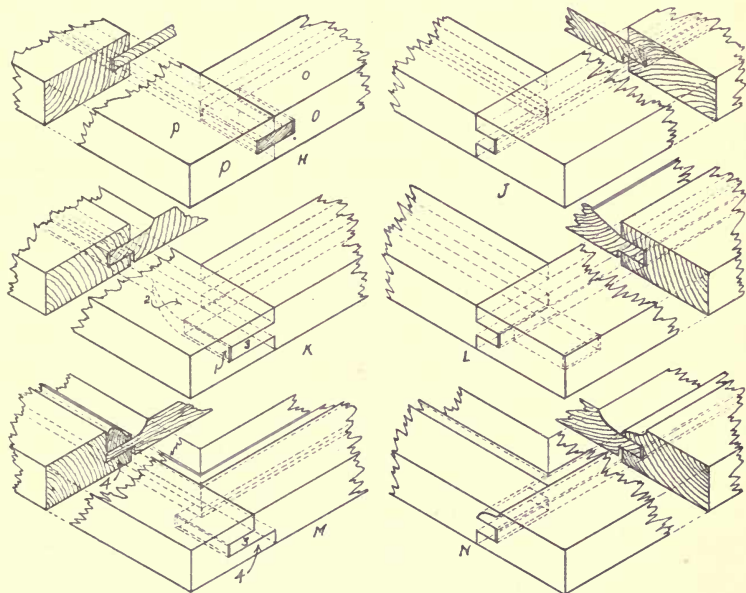
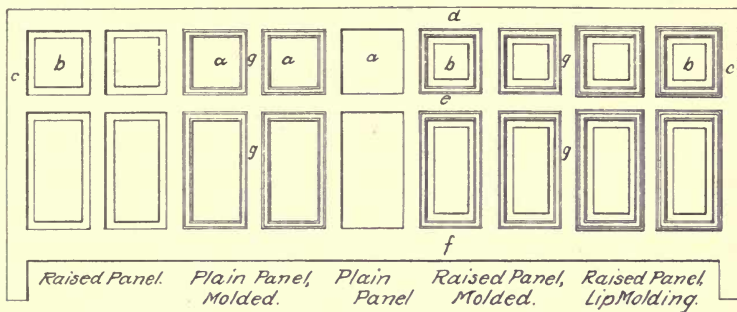

FIG. 17.—TYPES OF PANEL WORK AND METHODS OF CONSTRUCTION.

The top rail (*d*) is usually 1" wider than the stiles, to allow it to show the same width as the stile when the cap finish, similar to *p, r*, of Fig. 9, is in its place. One edge of the top rail and of the bottom rail (*f*) should be grooved, and their ends fitted to the stile. The bottom rail should be of a width to allow it to show at least $\frac{3}{4}$ " more than the width of the stiles when the base and the base molding are in place. The middle rail (*e*) should be somewhat narrower than the stiles, and grooved upon both edges, and fitted to receive the muntins (*g*) which should be the same width as the middle rails. The ends of the middle rails should be fitted to the stiles; the ends of the muntins should be fitted to the middle rails and also grooved to receive the panels.

Six different ways of constructing panel work are indicated. At *H* is shown the form of construction known as "*tongued and grooved*"; it should be used only in places where it will be firmly fastened, or where it will be required to do no more than to support its own weight. The thickness of the panel may equal the width of the groove, or it may be thicker, in which case it is rebated to allow it to enter the groove as shown at *J*. This is much better, as the panel, being thicker, is not so apt to be split by a blow.

The ends of the rails and muntins are grooved $\frac{9}{16}$ "; in this groove is placed a tongue, 1" long, made to fit closely, but not so tightly as to risk splitting the wood. The grain of the tongue should be parallel with the rails (*o*), so that when it is in place, it will be at right angles with the stile (*p*). This is usually done by planing a board to the thickness of the width of the groove, and cutting pieces 1" long off it as they are needed. If the work is well

made of dry material, and not roughly used, it will give very good satisfaction for a cheap grade of work.

J illustrates the panel *grooved and tenoned* construction, between which and *H* there is much similarity. It makes a better and stronger piece of work, and considering all things, it costs about the same. This form of construction is often reënforced by doweling the joints between the rails and stiles, and sometimes the joints of the muntins and rails are treated in the same way. The dowel holes must be bored before the grooves are made or there will be no center for the dowel bit.

In the *grooved and tenoned* method (*K*) the groove (1-2) is cut with a circular grooving saw about $1\frac{1}{4}$ " deep, the shape of the saw causing the curved shape indicated by the dotted lines. The tenon (3) is then fitted. The groove for the panels should be only $\frac{9}{16}$ " deep.

The *mortised and tenoned* joint, shown at *L*, is generally the method by which the best class of work is constructed. Instead of making the mortised joint, a doweled joint may be used. In this case there should be at least two dowels in each joint, which should be so located as to avoid the grooves which receive the panels. If a doweled joint is used, the holes must be bored before the pieces are grooved, or there will be no center for the dowel bit. If a mortised and tenoned joint is used, and the tenon coincides with the groove, there will not be so much work in digging out the mortise after the groove has been made. The doweled joint is often used, and with satisfaction, in shops which have neither mortising nor tenoning machines.

At *M* is shown *rebated* panel work ; this type is much used in places in which the work is built in because, if the

tenon (3) is omitted, it can be built one piece at a time, and can be nailed through the edges so that no nailheads will show. This method is sometimes applied by building the frame of square edged pieces, and furring out a distance equal to the back of the rebate (4). The thickness of a lath is about right for the furring. This form of construction is especially valuable in places where it is necessary that glass or wood panels should be put in place after the work is set up by using the back side of the pieces shown in the illustration as the face of the panel work. The panels may be put in from the back.

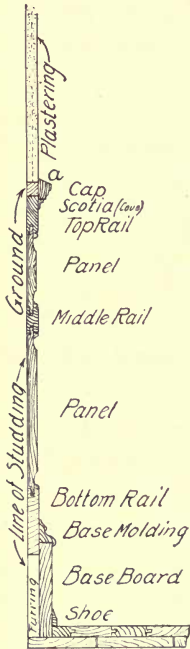

FIG. 18. — VERTICAL SECTION OF PANELED DADO AND SETTING.

At *N* is shown the *coped* panel work. This form of panel work is extensively used in the manufacture of furniture of all descriptions, and is abundantly strong for ordinary purposes. If good material is used, and the work is well done, a very handsome piece of work will result, as the effect of a molded panel will be obtained without the work of cutting in moldings, and there will be no nail holes visible.

(B.) Figure 18 shows the section of a paneled dado, with the different members used in setting it in place. The laps of the outside corners, around a chimney for instance, should be upon the side where they will be the least conspicuous; upon the best work these outside corners are mitered.

Panel work should be set directly upon the studding;

the spaces between the studding may be back plastered for either deadening or warmth, and the wall above plastered to a ground of the same thickness of the dado, as shown in Fig. 18, at *a*. One point of superiority of this method over nailing the dado upon the plastering, as is frequently done, is that the finish may be put on and the moldings stopped against the door casings much more easily and in a more workmanlike manner than if some of the moldings of the cap or base projected beyond the door casings, in which event they should be stopped by being returned upon themselves; that is, the contour of the face of the molding should be cut across the end, which will look as though the molding were mitered; small moldings should not be mitered if they return only their thickness, as the short grain of the return is apt to break off. Large moldings may be mitered when a return is necessary.

17. Rake dado may be made as easily as any other, if the work is done properly, the difficult parts being to get the clamps on so that they will not slip, and to prevent the muntins (*z*, Fig. 19) from slipping as the pressure is applied by the clamps.

As the top of the top rail and the bottom of the bottom rail of a piece of panel work usually are covered at least

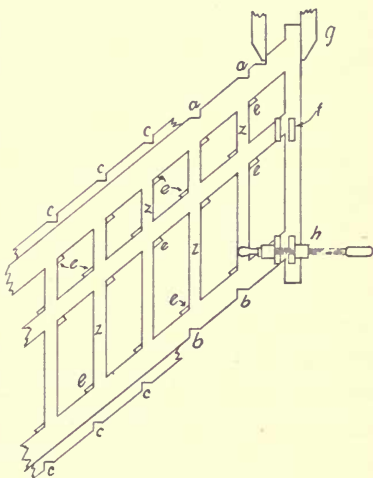

FIG. 19.—SETTING UP RAKE DADO.

one inch by the finish, they may be notched to receive the clamps as shown at *a*, *b*.

Another and better method is shown at *c*, Fig. 19, in which a piece $1\frac{1}{2}$ " wide is screwed to the outsides of the top and bottom rails to prevent their slipping, and the notches cut as indicated. These pieces may be used indefinitely upon similar work. To prevent the muntins from slipping when the pressure of the clamps is applied, a small piece of soft wood (*e*) may be cut upon the end at the angle at which the muntin intersects with the rails, and glued by a rub joint at the place where the long corner of the muntin will rest against it.

The panel work must be tried together to be sure that each piece will go to its place with the least pressure; pounding should be dispensed with as much as possible, as the small pieces (*e*) will be knocked off easily.

If there is trouble in getting the stiles on, they may be easily brought to their places by the glue blocks (*f*) being fastened on both sides of the rails and stiles, and hand screws applied. Hand screws (*h*) will draw the stiles up to a joint. The face of the stile should be fair with the face of the rail. This should be done at each joint of the rails and stiles; it is customary to put on the glue blocks (*f*) at the same time that the blocks (*e*) are applied. It is generally better to use cold glue for work of this sort.

Some workmen prefer to cut the ends of the rails, and make the joints against the stiles after the panel work has been glued up and the glue hardened, because it is sometimes difficult to keep the ends of the rails exactly in line. The top rail may be brought to the stile by applying a hand screw, as at *g*. The middle and bottom rails may be brought up to a joint by extending clamps across the face

of the panel work from the outside of the stile over a muntin; this method should be applied carefully, as the muntins may be pulled away from the rail, or the edges bruised. The former method is considered the better.

18. **Soffits.** — (A.) For a curved soffit, or the *jamb of an arched opening*, there are several methods of obtaining a piece of the desired sweep. One method known as

“kerfing” consists of making, with a clean cutting saw, a series of cuts or kerfs across the face of the soffit, and nearly through to the back. These cuts should not be made in a hit or miss manner, but at regular intervals, so that, when the soffit is bent to fit the arch, the sides of each

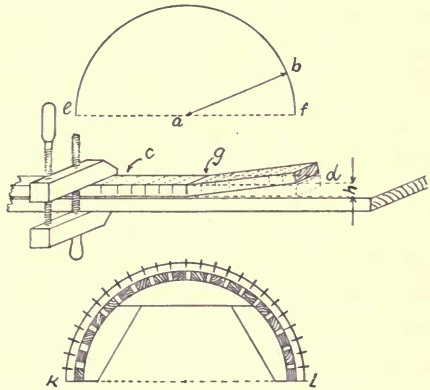

FIG. 20.—A SCARFED CIRCULAR SOFFIT.

saw cut will come together on the face. The distance between these cuts may be found by the method indicated in Fig. 20, in which ab and gd both equal the inside radius of the soffit.

The piece of wood from which the soffit is to be made should be of clear, straight-grained stock, and held upon a straight surface with a hand screw, as at c . The saw cut g should be made square with the edges of the piece, at the distance from the end of dotted lines d , which equals ab ; the end should then be lifted up until the saw cut g is brought together. The distance h should be carefully measured with a pair of compasses

and spaced from g a distance each way equal to the radius of the semicircle ef . All cuts should be made with the same saw with which the cut g was made, and to the same depth. In applying this method, it is necessary that the distance between the centers of the saw cuts shall equal exactly the distance h , so that when the soffit is in place the pressure necessary to bring it to the correct curve will force the sides of the cuts closely together, and conceal them as much as possible.

One objection to this method is that unless the face of the soffit is smoothed off with a crooked-faced smoother, after it is in place, the curve will appear to be a series of short faces between the cuts and, if the work is to be finished in the natural wood or stained, the cuts will show; if the wood is painted, a very satisfactory job may be made.

This work often is done by bringing the ends together and fastening them at the right place, after filling the saw cuts with glue. After the glue is set, the face may be smoothed off upon the bench.

Another modification of the same method is to make saw cuts in the back at equal intervals, and, after bending the soffit around a form to the correct curve, to fill the saw cuts with feathers of wood glued in, as shown at kl , Fig. 20.

After dressing the back off to the desired thickness, the piece may be handled as any straight piece, as it will hold its shape, though it will have but little strength.

(B.) A *circular soffit* may be made also of any kind of soft, flexible wood by preparing thin pieces which are to be bent to the desired form, the face piece being of the same kind of wood as the finish it is to match. These pieces should be bent to the required curve by means of pieces

fastened to the floor to the correct sweep, about twelve inches apart, as at *a*, Fig. 21, or over a form, as in Fig. 20. The pieces to be glued together are forced to the pieces upon the floor by means of hand screws, and held there until the glue has set.

There is a tendency for pieces glued in this way to straighten themselves. This may be counteracted by making the sweep a little smaller than desired, so that this tendency will bring it to about the proper sweep. As different kinds and thicknesses of wood act differently, no rule can be given which will apply generally,

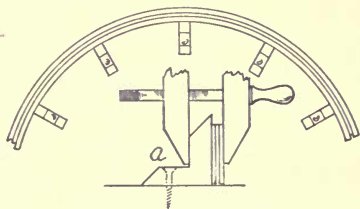

FIG. 21. — A BUILT CIRCULAR SOFFIT.

but a little experience will give the workman judgment. Usually, one twelfth or one fifteenth of the radius of the sweep will be a safe spring allowance. This is the method commonly used in cabinet shops upon the best class of work, as the piece may be handled with little danger of breaking it; if many are to be made, a form of the correct shape should be used, as that is the most economical way.

19. A splayed soffit for a circling top window may be made by the method described in Fig. 22. Points *a*, *c*, *b* show the face of the soffit, and *d*, *e*, *f*, the drop of the splay, or the size of the soffit at the window frame. At *g* may be seen the section of the reveal or jamb, its angle with the face of the casing, or line of the wall, being shown at *g*, *h*. It will be observed that *g*, *g*, *z* forms one half of a cone, and with *h*, *h* forms one half of the frustum of a cone. Thus we have the simple development of the frustum of a cone, one half of which will be the splayed soffit. With *z* as

center, and zg , as radius, describe the arc xy , and with the radius zh describe the arc vw , which will give the sweep of both edges of the soffit.

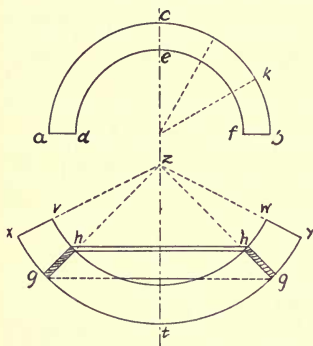

FIG. 22.—A SPLAYED SOFFIT.

Trisecting the arc bc , as at k , and spacing one of these three divisions six times upon the development of the frustum of the cone, working from the center e , we have the approximate length of the soffit, which should be cut longer to allow for fitting the vertical reveal casings. This splayed soffit may be bent by either of the methods described

in Topic 18, the saw scarfs radiating from the apex of the cone (z), or the center of the developed soffit.

20. Circular panel work.—In making circular panel work, the rails should be made and bent as shown in Fig. 21, the face piece (a , Fig. 23) being of the finish wood desired. The piece b , which forms the bottom of the groove into which the panel fits, should equal the desired width of the groove; the back piece (c) should be of the right thickness to make the rail match the straight panel work which it joins, or the stiles which are fitted upon the end.

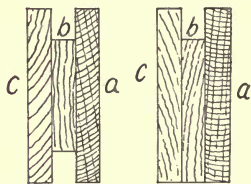

FIG. 23.—THE RAILS FOR CURVED PANEL WORK.

The rails may be built to any desired section, or for any method of construction used in panel work.

In circular panel work, the panels are usually plain and built up of several layers of veneer. If a raised panel is desired, the panels are sometimes planed to

the right curve and if a very quick sweep is wanted that may have to be done, but it is difficult to do it properly. This is a very laborious and expensive method, and the results rarely justify it; instead, it is quite the usual practice to warp the panels to the right curve after they have been molded or raised. This is done by wetting the side, which is to be convex, with moist sawdust, and exposing the other side to dry heat.

The panels should be watched carefully, and tried frequently with a pattern of exactly the desired curve, and when the panel has warped to fit the pattern, the wet sawdust should be brushed off, and the panel set where the air will reach both sides of it evenly, until it has dried thoroughly. As the panels are apt to straighten somewhat in drying, it is best to allow them to warp a little more than the pattern demands.

21. Closets. — (A.) Ample closets should be provided for various purposes, as nothing adds more to the livableness of a house, or appeals more to the heart of the housewife. In every kitchen there should be closets for groceries, dishes, etc. In many houses a dust and vermin proof closet is specified for holding the family linen. This closet should be fitted with shelves and drawers, the details of which generally are provided by the architect, or by the owner.

(B.) A *moth proof closet* should be built of a good grade of sound, well-seasoned lumber, and made proof against dust, moths, and vermin. The doors should be made tight by the use of weather strips; naphthaline or moth wax should be used plentifully to insure against damage by insect pests. A red cedar chest or closet, while new, is satisfactory, but the wood loses its aroma in a few years,

after which, unless the surface is planed, it is no more moth proof than any other wood, though it may still resist the ravages of boring insects and of mice.

(C.) *China closets* are built usually in the dining room. They should have glass doors, and be at least 12'' deep in the clear inside. *Clothes closets* may be of almost any size, but they should not be less than 48'' high. They should be provided with hooks; if there is a shelf, the capacity of the closet may be increased by screwing into its under side hooks which are especially useful as places to hang garments which are on forms.

(D.) The *pantry* should have shelves not less than 10'' wide above the principal shelf, which may be from 18'' to 30'' wide, and 30'' from the floor, to be used for a working table. Covers should be arranged in the wide shelf for the flour and sugar barrels, which should be in a closet underneath. Bins for meal, etc., are often wanted by the owner, who usually decides how the shelving is to be arranged. In the best houses, the pantry shelves are inclosed by doors, but this is not often done upon ordinary work.

(E.) A large *trunk closet*, or one for general storage, is a great convenience. In most houses planned by architects, these closets and their details are carefully worked out, and the carpenter who fits up these and other little conveniences in a new house is sure to be appreciated.

22. A **drawer case** for bedding, linen, or clothing is frequently needed, and should be placed where it is easily accessible from the bedrooms. It is a good plan to place it in a closet, so that when the door is closed the case will be out of sight. In some places the case of drawers may be placed across the end of a closet or alcove, so that there will

be no need of finishing the ends. Such a case is shown in Fig. 24.

In making the drawer case as illustrated, the joints of the partition frames (*a*) should be made by being tongued

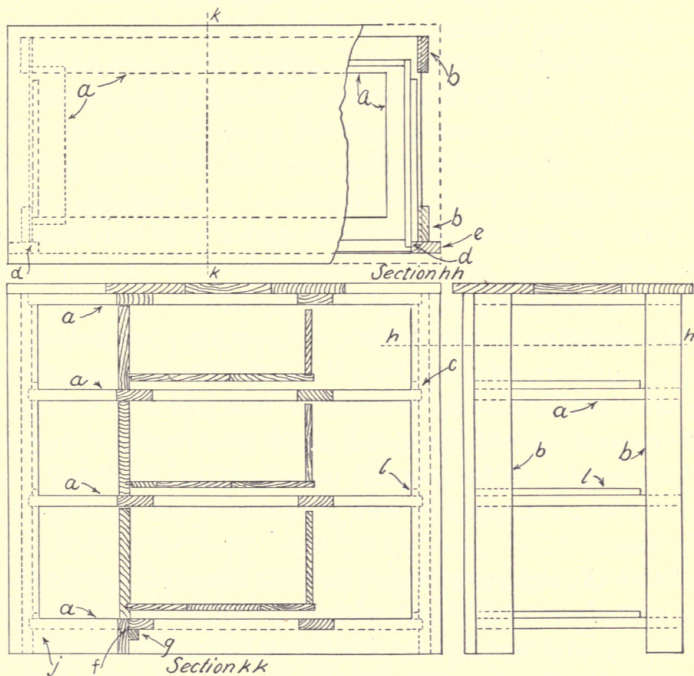

FIG. 24. — SKETCH FOR A DRAWER CASE.

and grooved, or doweled at the corners and glued. The standards (*b*) which support the partitions should be grooved at *c*, at the proper distances to fit the drawers which slide between them.

After the glue has set, the partitions should be planed square and fair, and all but the bottom one notched, as at

d, to receive the casings (*e*). The front rail of the bottom partition should be made narrow to allow the base to be glued upon it, as at *f*, the joint being strengthened by glue blocks (*g*) if desired. The standards and partitions may now be nailed together, the casings (*e*) and the base (*f*) being glued and nailed with finish nails, unless a very good piece of work is being done, when the pieces should be glued only. If nails are used, it will not be necessary to leave hand screws upon the work until the glue sets. The joint at *j*, between the casing and base, should be mortised, tongued and grooved, or doweled. One casing may be left loose if desired, as it will be easier to fit the case into the space which is to receive it, though if one end of the case is finished, the casings should be fastened permanently.

Be sure that a case of this sort is set up square, as it will save much trouble in fitting the drawers, the construction of which is indicated by sections *h, h* and *k, k*. The top of the case should be glued up, if one board of suitable width cannot be found, and may be either fastened on or left loose, as may seem wise considering the setting up of the case.

After the drawer is fitted and the front planed, leave it with the front flush with the face of the case, and mark with a pencil beside the drawer sides on the partitions; remove the drawer and nail the runs (*l, l*) in their places. It is obvious that any slight inaccuracy in the squaring of the drawer will make no difference in its running. After the runs are in place, the drawer should be stopped $\frac{1}{8}$ " or less back of the face of the case by nailing a piece back of the drawer to prevent its being pushed in too far.

The dimensions of the case shown are purposely omitted, as each piece of work will have its own length if the case is

to be fitted in; but cases in general range between 2' 6'' and 3' 0'' in height, and 16'' and 24'' in depth.

In fitting a drawer, many workmen make the mistake of running it too loosely; it should run as closely as possible against the guides. The less that can be planed from the bottom edges of the drawer sides the better, as any taken off there weakens the support of the drawer bottom; if the sides are too wide, they should be made narrower by planing off the top edge.

Be sure that the bottom of the drawer front does not drag on the partition, also that the ends of the front clear the space in which it runs, for if the outside of the face of the drawer front rubs against the case, it may splinter. Care should be used to leave an open joint; the least possible difference between the ends of the opening and the drawer front is sufficient.

The use of a wax candle, paraffin wax, bayberry tallow, or even a piece of soap, upon the drawer and guides where there is apt to be friction, is of great help. If a drawer runs hard in damp weather, do not plane off more than is absolutely necessary, as artificial heat will cure almost any drawer which ever fitted, if it is made of seasoned stock.

23. A kitchen sink should be set with a pitch toward the drain to allow the water to run off freely. The drain should be connected with a sewer, or carried to a sufficient distance to insure that there will never be any annoyance from it; this work should be done by a plumber in a sanitary manner. Upon one side of the sink, usually at the left, there should be a dish drainer for conducting the water into the sink as it drains from the dishes; this should be set at an incline of about 1'' to 1', as shown in Fig. 25, at *a*.

There should be no closet under the sink; the place should be left open to allow a free circulation of air.

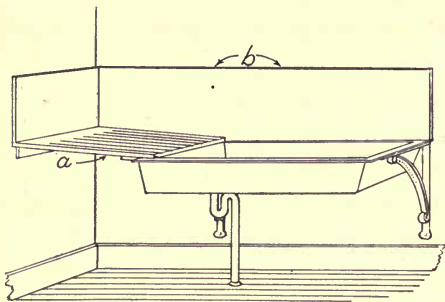

FIG. 25.—A KITCHEN SINK.

A splash board (*b*) should protect the wall from water, back of and above the sink.

24. The bathroom should be finished with well-seasoned wood, of a kind which is but little affected by dampness, and have either a ceiling or panel work dado, well painted and finished to protect it against water. As the modern open plumbing and the tile or marble bathrooms have supplanted the older fittings which had to be boxed in, there is little opportunity for woodwork in the bathroom of the modern house.

25. Wood mantels, hardware, and other special finish are often furnished by the owner, though a limit to the price may be specified in the contract. Any expense incurred in pleasing the owner's fancy is figured as an extra, though the best plan is to keep the cost of extras as low as possible, since it often causes misunderstanding, unless each matter is settled in writing as it occurs.

SUGGESTIVE EXERCISES

11. Is floor laying always done by house carpenters? What kinds of floors are in most common use? How should a matched floor be nailed? Which is the more expensive floor? Why? Should a floor be nailed at every joist? How should paper be laid under a floor? How should the stock for a natural finish floor be selected? Compare the merits of wide and narrow flooring. Why is the starting of a

matched floor an important matter? How is it brought about upon a floor which fits against the baseboard? Under the baseboard? What is the objection to using a quarter round or shoe strip? Will anything be gained by selecting the grain in the boards of a floor which is to be smoothed? How is a square-edged floor laid?

12. What is meant by inside finish? How should finish be sorted for colors? Why? Is it a good plan to use different woods in the same room? Does this rule apply to doors? What should be the relation of the tops of openings to each other? Is this usually followed? Why? What woods may be used for inside finish? What woods are unsuitable? What quality of material should be used?

13. Describe the different styles of casings. Compare the size of a corner block with that of the side casing. Compare the size of a lintel or header with that of its architrave. For what is a plinth useful? How should the bottom of a plinth be cut to allow a carpet to go under it? Should door casings be set flush with the edge of the doorframe? Why is this done? Is the finish put around a window in the same way? Is it good practice to splice a casing? Why is it cheaper to put the finish upon a perfectly plumb and square frame, than upon any other? What is the correct way to place the grain of a corner block? Why?

14. What part of a molding governs its use? Describe the shape of a band molding; of a base molding. How should a base molding be nailed? Why? Describe the shape and use of a cap molding. Of the bed mold. How should a bed mold be mitred? Describe a panel molding. How should it be nailed to its place? Why? For what is an astragal molding often used? Describe a crown molding. Describe the quarter round and some of its uses. Upon what grade of work is it much used? How is it used in putting up partitions? Describe the scotia and some of its uses. Describe a nosing and some of its uses. Describe a half round and some of its uses. For what purposes are beads used? Stop beads? Describe picture or room moldings. Describe the process of coping a room or base molding. What is the objection to mitering the inside corner of a base or room molding? Of what are large cornices composed? From what are the forms of moldings taken? How many types of moldings were used by the ancients? Describe the ovolo; the talon and quirk; the cyma recta; the cyma reversa; the cavetto; the torus; the astragal. Give the uses and location of the above moldings. What form did the ancients

avoid in designing moldings? What should be the angle of the face line of a cornice with the frieze? What is the usual width of baseboards? What will happen if the base is put on before the plastering is thoroughly dry? How is the base put on if a single floor is to be used? A double floor? Compare the two. How should the inside and outside corners of a baseboard be fitted for best results? From what quality of lumber should moldings be made? What mark of a good workman is shown by his work with moldings?

15. Describe the method of finding the joint between a straight and a circling molding.

16. Should exact dimensions be taken from the architect's plans or from the house itself? How may dado be made? Describe different methods of building panel work. Describe the members of a piece of panel work. How should laps of outside corners be made? How is a building prepared for panel work which is to be set flush with the face of the plastering? Compare the merits of setting the panel work flush with the face of the plaster, or on the plaster. How should moldings which project beyond the finish be treated?

17. Describe two methods of putting the clamps upon a piece of rake dado. How may the muntins be prevented from slipping? How may the stiles be put on?

18. Describe the method of finding the cuts for kerfing. How are circular soffits made? Describe the best method.

19. How may a splayed soffit be laid out?

20. How may the rails of circular panel work be made? How should the panels be treated to fit them to the sweep?

21. What closets should be provided in the kitchen? How may a moth proof closet be made? Is a red cedar closet a permanent preventive of moths? Describe the location and depth of a china closet. Describe a clothes closet, and its fittings. Describe a pantry.

22. What is a common mistake in running in a drawer? If the sides of a drawer are too wide, should they be planed off at the top or at the bottom? Why? How should the drawer front be fitted to prevent splintering at the ends? What will make a drawer run easier?

23. Describe the fittings of a sink.

24. Describe the fittings of a modern bathroom.

25. How are wood mantels sometimes purchased? What must the builder guard against when extras are asked for? How?

CHAPTER III

DOORS

26. **Doors** for all ordinary purposes can be purchased in stock sizes much more reasonably than if they were made to order. Stock doors usually are doweled, and if well made of thoroughly seasoned material are perfectly satisfactory; a doweled door can be made more economically than a mortised door, therefore it is sold at a less price, but if well made it will give just as good satisfaction.

For a $1\frac{3}{8}$ " door, $\frac{1}{2}$ " dowels, placed "staggering," as shown in Fig. 26, will make a stronger job than if a mortised joint were used, other things being equal. These doors usually are coped after the dowel holes are bored, as otherwise there will be no center for the bit. The grooves for the panels should be $\frac{9}{16}$ " deep, to allow the panels which enter $\frac{1}{2}$ " to swell $\frac{1}{8}$ " without opening the joints between the rails and stiles. Sometimes a shallower groove and cope are used, the panels being proportionately narrower.

The joints in the doors are made by machinery, and are forced to their places and held there by clamps while the glue sets.

27. **Stock sizes** of doors cover a wide range, but those most commonly used are 2' 6" \times 6' 6", 2' 8" \times 6' 8", 2' 10" \times 6' 10", 3' 0" \times 7' 0"; either $1\frac{3}{8}$ " or $1\frac{3}{4}$ " thick.

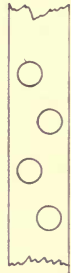

FIG. 26.— POSITION OF DOWELS.

TABLE OF REGULAR SIZES

WIDTH	LENGTH	THICK- NESS	WIDTH	LENGTH	THICK- NESS	WIDTH	LENGTH	THICK- NESS
2' 0" X 6' 0" X 1 $\frac{3}{8}$ "	2' 8" X 6' 6" X 1 $\frac{3}{8}$ "	2' 6" X 8' 0" X 1 $\frac{3}{8}$ "	2' 6" X 6' 0" X 1 $\frac{3}{8}$ "	2' 10" X 6' 6" X 1 $\frac{3}{8}$ "	2' 8" X 8' 0" X 1 $\frac{3}{8}$ "	2' 0" X 6' 0" X 1 $\frac{3}{8}$ "	2' 8" X 6' 0" X 1 $\frac{3}{8}$ "	2' 6" X 6' 0" X 1 $\frac{3}{8}$ "
2' 6" X 6' 0" X 1 $\frac{3}{8}$ "	3' 0" X 6' 6" X 1 $\frac{3}{8}$ "	3' 0" X 8' 0" X 1 $\frac{3}{8}$ "	2' 6" X 6' 6" X 1 $\frac{3}{8}$ "	2' 0" X 6' 8" X 1 $\frac{3}{8}$ "	3' 0" X 8' 0" X 1 $\frac{3}{8}$ "	2' 6" X 6' 0" X 1 $\frac{3}{8}$ "	2' 8" X 6' 6" X 1 $\frac{3}{8}$ "	2' 6" X 6' 6" X 1 $\frac{3}{8}$ "
2' 8" X 6' 0" X 1 $\frac{3}{8}$ "	2' 0" X 6' 8" X 1 $\frac{3}{8}$ "	3' 0" X 8' 6" X 1 $\frac{3}{8}$ "	2' 8" X 6' 6" X 1 $\frac{3}{8}$ "	2' 4" X 6' 8" X 1 $\frac{3}{8}$ "	3' 0" X 8' 6" X 1 $\frac{3}{8}$ "	2' 8" X 6' 0" X 1 $\frac{3}{8}$ "	2' 0" X 6' 8" X 1 $\frac{3}{8}$ "	2' 8" X 6' 8" X 1 $\frac{3}{8}$ "
3' 0" X 6' 0" X 1 $\frac{3}{8}$ "	2' 4" X 6' 8" X 1 $\frac{3}{8}$ "	3' 0" X 9' 0" X 1 $\frac{3}{8}$ "	2' 0" X 6' 8" X 1 $\frac{3}{8}$ "	2' 6" X 6' 8" X 1 $\frac{3}{8}$ "	2' 6" X 6' 8" X 1 $\frac{3}{8}$ "	2' 6" X 6' 0" X 1 $\frac{3}{8}$ "	2' 6" X 6' 8" X 1 $\frac{3}{8}$ "	2' 8" X 6' 8" X 1 $\frac{3}{8}$ "
2' 0" X 6' 6" X 1 $\frac{3}{8}$ "	2' 6" X 6' 8" X 1 $\frac{3}{8}$ "	2' 6" X 6' 6" X 1 $\frac{3}{8}$ "	2' 6" X 6' 8" X 1 $\frac{3}{8}$ "	3' 0" X 6' 8" X 1 $\frac{3}{8}$ "	2' 10" X 6' 10" X 1 $\frac{3}{8}$ "	2' 8" X 6' 8" X 1 $\frac{3}{8}$ "	2' 10" X 6' 10" X 1 $\frac{3}{8}$ "	3' 0" X 6' 8" X 1 $\frac{3}{8}$ "
2' 6" X 6' 6" X 1 $\frac{3}{8}$ "	2' 8" X 6' 8" X 1 $\frac{3}{8}$ "	2' 10" X 6' 10" X 1 $\frac{3}{8}$ "	2' 8" X 6' 8" X 1 $\frac{3}{8}$ "	2' 6" X 6' 10" X 1 $\frac{3}{8}$ "	2' 8" X 6' 10" X 1 $\frac{3}{8}$ "	2' 8" X 6' 8" X 1 $\frac{3}{8}$ "	2' 8" X 6' 10" X 1 $\frac{3}{8}$ "	2' 8" X 6' 10" X 1 $\frac{3}{8}$ "
2' 8" X 6' 8" X 1 $\frac{3}{8}$ "	2' 10" X 6' 10" X 1 $\frac{3}{8}$ "	2' 8" X 7' 0" X 1 $\frac{3}{8}$ "	2' 10" X 6' 10" X 1 $\frac{3}{8}$ "	2' 8" X 6' 10" X 1 $\frac{3}{8}$ "	2' 10" X 6' 10" X 1 $\frac{3}{8}$ "	2' 10" X 6' 10" X 1 $\frac{3}{8}$ "	2' 10" X 6' 10" X 1 $\frac{3}{8}$ "	2' 10" X 6' 10" X 1 $\frac{3}{8}$ "
2' 10" X 6' 10" X 1 $\frac{3}{8}$ "	3' 0" X 7' 0" X 1 $\frac{3}{8}$ "	2' 8" X 7' 0" X 1 $\frac{3}{8}$ "	2' 4" X 7' 0" X 1 $\frac{3}{8}$ "	2' 8" X 7' 0" X 1 $\frac{3}{8}$ "	2' 10" X 7' 0" X 1 $\frac{3}{8}$ "	2' 10" X 7' 0" X 1 $\frac{3}{8}$ "	2' 10" X 7' 0" X 1 $\frac{3}{8}$ "	2' 10" X 7' 0" X 1 $\frac{3}{8}$ "
3' 0" X 7' 0" X 1 $\frac{3}{8}$ "	2' 0" X 6' 0" X 1 $\frac{3}{8}$ "	2' 10" X 7' 0" X 1 $\frac{3}{8}$ "	2' 6" X 7' 0" X 1 $\frac{3}{8}$ "	2' 8" X 7' 0" X 1 $\frac{3}{8}$ "	3' 0" X 7' 0" X 1 $\frac{3}{8}$ "	3' 0" X 7' 0" X 1 $\frac{3}{8}$ "	3' 0" X 7' 0" X 1 $\frac{3}{8}$ "	3' 0" X 7' 0" X 1 $\frac{3}{8}$ "
2' 0" X 6' 0" X 1 $\frac{3}{8}$ "	2' 6" X 6' 0" X 1 $\frac{3}{8}$ "	2' 6" X 7' 0" X 1 $\frac{3}{8}$ "	2' 8" X 7' 0" X 1 $\frac{3}{8}$ "	2' 10" X 7' 0" X 1 $\frac{3}{8}$ "	2' 6" X 7' 6" X 1 $\frac{3}{8}$ "	2' 6" X 7' 6" X 1 $\frac{3}{8}$ "	2' 6" X 7' 6" X 1 $\frac{3}{8}$ "	2' 6" X 7' 6" X 1 $\frac{3}{8}$ "
2' 6" X 6' 0" X 1 $\frac{3}{8}$ "	2' 8" X 6' 0" X 1 $\frac{3}{8}$ "	2' 8" X 7' 6" X 1 $\frac{3}{8}$ "	2' 8" X 7' 0" X 1 $\frac{3}{8}$ "	2' 8" X 7' 0" X 1 $\frac{3}{8}$ "	2' 8" X 7' 6" X 1 $\frac{3}{8}$ "	2' 8" X 7' 6" X 1 $\frac{3}{8}$ "	2' 8" X 7' 6" X 1 $\frac{3}{8}$ "	2' 8" X 7' 6" X 1 $\frac{3}{8}$ "
2' 8" X 6' 0" X 1 $\frac{3}{8}$ "	3' 0" X 6' 0" X 1 $\frac{3}{8}$ "	2' 10" X 7' 6" X 1 $\frac{3}{8}$ "	2' 10" X 7' 0" X 1 $\frac{3}{8}$ "	2' 10" X 7' 0" X 1 $\frac{3}{8}$ "	2' 10" X 7' 6" X 1 $\frac{3}{8}$ "	2' 10" X 7' 6" X 1 $\frac{3}{8}$ "	2' 10" X 7' 6" X 1 $\frac{3}{8}$ "	2' 10" X 7' 6" X 1 $\frac{3}{8}$ "
3' 0" X 6' 0" X 1 $\frac{3}{8}$ "	2' 4" X 6' 4" X 1 $\frac{3}{8}$ "	3' 0" X 7' 6" X 1 $\frac{3}{8}$ "	3' 0" X 7' 0" X 1 $\frac{3}{8}$ "	3' 0" X 7' 0" X 1 $\frac{3}{8}$ "	3' 0" X 7' 6" X 1 $\frac{3}{8}$ "	3' 0" X 7' 6" X 1 $\frac{3}{8}$ "	3' 0" X 7' 6" X 1 $\frac{3}{8}$ "	3' 0" X 7' 6" X 1 $\frac{3}{8}$ "
2' 4" X 6' 4" X 1 $\frac{3}{8}$ "	2' 6" X 6' 4" X 1 $\frac{3}{8}$ "	2' 6" X 8' 0" X 1 $\frac{3}{8}$ "	2' 6" X 7' 6" X 1 $\frac{3}{8}$ "	2' 6" X 7' 6" X 1 $\frac{3}{8}$ "	2' 6" X 8' 0" X 1 $\frac{3}{8}$ "	2' 6" X 8' 0" X 1 $\frac{3}{8}$ "	2' 6" X 8' 0" X 1 $\frac{3}{8}$ "	2' 6" X 8' 0" X 1 $\frac{3}{8}$ "
2' 6" X 6' 4" X 1 $\frac{3}{8}$ "	2' 0" X 6' 6" X 1 $\frac{3}{8}$ "	2' 8" X 8' 0" X 1 $\frac{3}{8}$ "	2' 8" X 7' 6" X 1 $\frac{3}{8}$ "	2' 8" X 7' 6" X 1 $\frac{3}{8}$ "	2' 8" X 8' 0" X 1 $\frac{3}{8}$ "	2' 8" X 8' 0" X 1 $\frac{3}{8}$ "	2' 8" X 8' 0" X 1 $\frac{3}{8}$ "	2' 8" X 8' 0" X 1 $\frac{3}{8}$ "
2' 0" X 6' 6" X 1 $\frac{3}{8}$ "	2' 4" X 6' 6" X 1 $\frac{3}{8}$ "	3' 0" X 8' 0" X 1 $\frac{3}{8}$ "	2' 10" X 7' 6" X 1 $\frac{3}{8}$ "	2' 10" X 7' 6" X 1 $\frac{3}{8}$ "	3' 0" X 8' 0" X 1 $\frac{3}{8}$ "	3' 0" X 8' 0" X 1 $\frac{3}{8}$ "	3' 0" X 8' 0" X 1 $\frac{3}{8}$ "	3' 0" X 8' 0" X 1 $\frac{3}{8}$ "
2' 4" X 6' 6" X 1 $\frac{3}{8}$ "	2' 6" X 6' 6" X 1 $\frac{3}{8}$ "	3' 0" X 8' 6" X 1 $\frac{3}{8}$ "	3' 0" X 7' 6" X 1 $\frac{3}{8}$ "	3' 0" X 7' 6" X 1 $\frac{3}{8}$ "	3' 0" X 8' 6" X 1 $\frac{3}{8}$ "	3' 0" X 8' 6" X 1 $\frac{3}{8}$ "	3' 0" X 8' 6" X 1 $\frac{3}{8}$ "	3' 0" X 8' 6" X 1 $\frac{3}{8}$ "
2' 6" X 6' 6" X 1 $\frac{3}{8}$ "	3' 0" X 6' 6" X 1 $\frac{3}{8}$ "	3' 0" X 9' 0" X 1 $\frac{3}{8}$ "	3' 0" X 8' 6" X 1 $\frac{3}{8}$ "	3' 0" X 8' 6" X 1 $\frac{3}{8}$ "	3' 0" X 9' 0" X 1 $\frac{3}{8}$ "	3' 0" X 9' 0" X 1 $\frac{3}{8}$ "	3' 0" X 9' 0" X 1 $\frac{3}{8}$ "	3' 0" X 9' 0" X 1 $\frac{3}{8}$ "

Doors other than those commonly used are generally made in these same sizes, but they are kept in stock by none but the largest dealers.

28. Selection. — In selecting a door, be sure that the material and workmanship are all that the quality of the door demands, and that it is straight and out of wind; if these things are carefully considered in purchasing doors, time will be saved in hanging them.

Upon ordinary work the doors may be of any wood, regardless of the finish of the rest of the house, though often they are veneered to match the rooms which the doorway connects.

Solid doors are made of white pine, cypress, Carolina

pine, and poplar or whitewood, generally preferred in the order named.

There are usually three grades of doors recognized: #1, #2, #3 or common. The #1 door is supposed to be first-class in every respect; the #2 door may have a few blemishes which do not injure its strength or appearance greatly, and is the grade of door commonly used. A common door is of poor stock and workmanship, and is used only upon the cheapest grade of work, usually receiving a coat of cheap paint at the factory, to cover up some of the defects.

29. **Veneered doors**, if well made, are in general more serviceable than other kinds. Solid hardwood doors will

not hold their shape well, therefore they are veneered by the following process. A core (see *a* of Fig. 27) of thoroughly seasoned white pine is made by ripping a plank

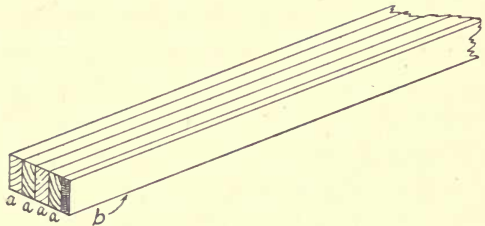

FIG. 27.—THE GLUED CORE FOR A VENEERED DOOR.

$1\frac{3}{8}$ " or $1\frac{3}{4}$ " thick into pieces at least $\frac{1}{4}$ " wider than the finished thickness of the core; these pieces are laid side by side or turned upon their edges, as shown at *a, a, a, a*, Fig. 27, until, with the face edge *b*, they aggregate a little more than the desired width of the member of the door for which the core is intended. The pieces are then turned end for end, or other edge up, to cross the grain, as at *a*, Fig. 27, thus counteracting the tendency of the different pieces to change their shape. After the joints have been fitted, the pieces are glued together. A piece of the finish wood

should be glued upon one edge of the stile at the same time, as at *b*, Fig. 27. After the glue has set, all the cores of the door should be jointed straight and out of wind and dressed to the desired thickness.

In preparation for veneering the sides of the cores, the backs of the veneers and each side of the cores should be planed with a scratch or tooting plane, to make the glue hold better. Veneering should be done in a hot shop, with wood thoroughly heated, and with hot glue, which should be of about the consistency of cream, so that it will spread evenly and rapidly. The glue should be applied with a broad glue brush, not a paint brush in which the bristles are usually set in glue, or the glue in the brush will soften and allow the bristles to come out. The glue should be spread thickly enough to cover the wood well, and the veneer of both sides put on at the same time. Several pieces of the same size may be piled and glued at once, and placed in a veneer press, or it is sometimes done with large hand screws, if a veneer press is not available. The former method is the better, but as the work has to stay in the press until the glue sets, few shops are fitted with a sufficient number of veneer presses to allow of their use exclusively. Care should be used that no glue is spattered upon the face side of the veneer, or the pieces will stick together. A caul, or a piece of thick, straight wood of the proper size, is placed between the hand screws or veneer press and the veneers of the outside pieces. The caul should be a little larger than the work which is being veneered; it should be waxed carefully to prevent the glue from sticking to it, and placed where every part of the surface of the veneer will be under pressure. The pile should be built carefully, to be sure that it is straight

and square, and that every part of each piece will receive the required pressure. The pile should be built vertically; unless this is done accurately, the pile may "buckle" or break when pressure is applied.

When the veneers have been glued upon the cores, the stiles and rails should be of the desired thickness of the door. After the veneering is done, proceed as with solid pieces.

30. **The doorframes**, if the finish is to be in the natural wood, should be of the same kind of wood as the trimming of the rooms which the door connects. Usually they are made $1\frac{1}{2}$ " or $1\frac{3}{4}$ " thick, and in width equal to the thickness of the partition, and rabbeted to fit the thickness of the door.

Upon common work, the door jamb is often made of $1\frac{1}{2}$ " stock. However, when rabbeted, this is not thick enough to hold the screws of the hinges properly. If this thickness of stock is used, a stop is sometimes nailed on to form the rabbet. This is not a workmanlike thing to do, as the stop is apt to be loosened by the slamming of the door. If $1\frac{1}{2}$ " jambs have to be used, grooves should be cut into them as shown at *a*, Fig. 28, to hold the stops.

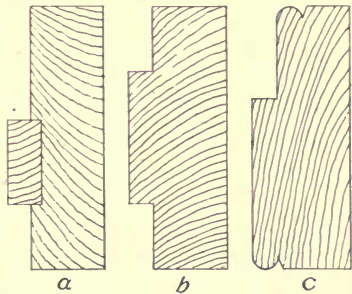

FIG. 28.—DOOR JAMBS.

There are several styles of door jambs or frames, but those shown are the ones most commonly used. Figure 28, *b*, is a popular form, as the door may be hung upon either side of the jamb. Doorframes between rooms which

are finished in different woods are veneered to match the rooms in the best class of work.

Door jambs like *a* and *b*, Fig. 28, generally are fitted together with a butt joint, as shown at *a*, Fig. 29, and those

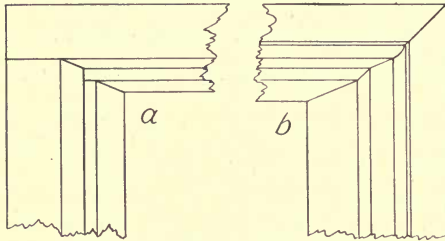

FIG. 29.—JOINTS OF DOOR JAMBS.

like *c* are mitered, as shown in Fig. 29, *b*. They should be fastened together by spikes, and squared, being held by battens tacked diagonally across the openings

from stile to header, and across the bottom of the frame to hold the stiles parallel. This is very important since, if the doorframe is not square, there will be trouble all through the casing and in hanging the door.

31. The doorframes of a brick house are wider than those of a frame building, as the walls are thicker. The frame is sometimes set as shown in Fig. 30. In this way any size of frame stock may be used, though a paneled frame as wide as the thickness of the wall is often preferred.

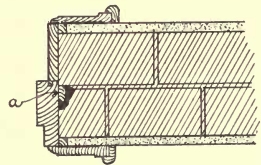

FIG. 30.—SETTING A DOOR-FRAME IN BRICKWORK.

32. Setting doorframes.—To set a doorframe economically, the opening left in the studs should be plumb on the sides, both ways, and 1" wider and $\frac{1}{2}$ " higher than the outside of the doorframe. In this opening, the doorframe should be set perfectly plumb and out of wind, in which position it should be wedged and fastened securely.

The time spent in setting a doorframe accurately is

more than compensated for in fitting the casings around it, and in fitting and hanging the door. If the doorframe is not set plumb, the door will swing of itself unless it is fastened open or closed.

Wedges or "shims" should be placed between the frame and the stud to allow the frame to be nailed straight; they are used also where the hinges are to be set, so that if it is ever necessary to put a long screw in the hinge, there will be wood to hold it. In setting a $1\frac{1}{2}$ " frame this always should be done.

In setting the doorframes of a brick house, a piece should be nailed the entire length of the wall side of the frames, so that the wall may be built around it, as at *a*, in Fig. 30. It should be so placed that the bricks will have to be cut as little as possible. A piece of $2'' \times 4''$ or $2'' \times 6''$ should be laid in the brickwork at the bottom of the door opening, level with the floor, to give a nailing for the flooring and the threshold.

It is the carpenter's business to assist the mason in setting the frame, and he should see that it is securely braced plumb and out of wind before the wall is built around it.

33. Jointing. — A door should be jointed before the threshold is cut down, and the edges made to fit the rabbets of the frame closely. In doing this, the advantage of setting the doorframe accurately will be appreciated.

The door should be fitted carefully to the header or top of the doorframe, at *a*, Fig. 31, pushed into its place, and wedged there, as at *b*.

The threshold, or a piece of the same thickness, should then be placed against the bottom of the door, as at *c*, and a pencil line (*d*) made on the door, to indicate the exact length of the door after the threshold is in place. The

door should be sawed off about $\frac{1}{8}$ " shorter than this line. If a carpet is to be laid over the threshold, either the door should be still shorter, or the threshold planed thinner.

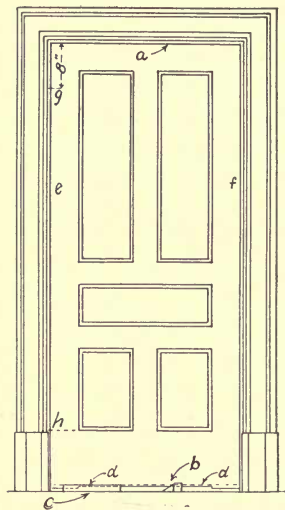

FIG. 31.—A FITTED DOOR.

It is a good plan to dispense with a threshold by building up $\frac{3}{8}$ " or $\frac{1}{2}$ " under the floor; this generally will allow the door to swing over a carpet or rug.

34. Hanging a door.—In hanging, or fitting the hinges to a door, trouble will be saved by using care and accuracy at each step of the work. If the hinge stile of the door is not perfectly straight sideways, the rounding side should be placed next the rabbet, as a good joint between the door and the back of the rabbet can be more easily

made than if the hollow side of the stile were to be fitted. This applies more especially to the hinge joint, as a slight hollow in the lock stile will be remedied by the latch.

After the door has been fitted to the side and head rabbets, as at *a*, *e*, *f*, Fig. 31, it should be dropped $\frac{1}{16}$ " by drawing out the wedge (*b*). Make a knife mark 8" from the top of the door, at *g*, to which the top end of the upper hinge should be placed; for the bottom of the lower hinge, make another mark at *h*, on line with the top of the bottom rail of the door. These marks should be made upon both door and doorframe simultaneously.

Remove the door; stand it edgewise on the floor with the hinge edge up; lay the hinge carefully in its place, the

top end at *g*, Fig. 32. With a knife, mark carefully the other edge of the hinge at *s*. Make corresponding marks in the rabbet of the doorframe, at *j*, Fig. 32. Gauge from the rabbet or back side of the door, or the side which fits against the rabbet, the distance, *k*, which marks the location of the back edge of the hinge. This distance is governed by the thickness of the door, and the projection of the round of the hinge beyond the face of the door, necessary to allow the door to swing wide open and clear the finish.

With a piece of wood of the same thickness as *k*, or the above gauged distance, laid in the rabbet of the doorframe, make the mark, *m*. This is the exact location in the rabbet of the back edge of the other half of the hinge.

Square the top and bottom marks of the hinge (*g*, *s* and *j*, *j*) to the lines *k* and *m*. Make the gauge mark upon the face of the door at *n*, and upon the frame at *p*, to denote the depth of the slot, in which each half of the hinge is to rest.

This should be of such a depth that the joint between the door and the frame at *r* will be a little less than $\frac{1}{16}$ " , to insure that the paint upon the door and upon the frame will not make the door "hinge-bound." With a sharp

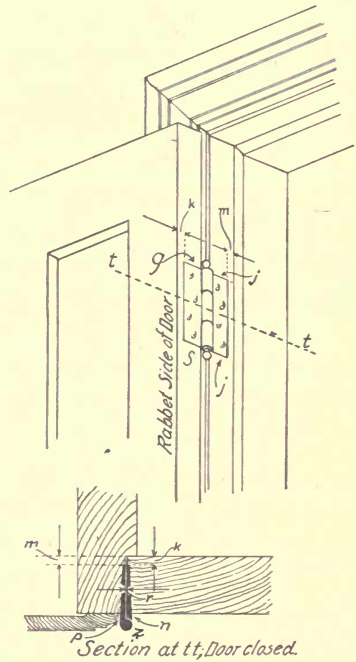

FIG. 32.—CUTTING IN THE HINGES.

chisel, cut carefully to the lines of both the top and bottom hinges; bore holes for the screws, and fasten the hinges on. Ordinarily a $1\frac{1}{4}$ " screw is used for this purpose.

If the door is sprung, and strikes the rabbet of the frame on the hinge stile, or does not fit the rabbet on the lock edge (*f*, Fig. 31), do not plane the stile of the door to fit, but instead mark the rabbet carefully, and with a rabbet plane take from the jamb the wood which prevents the door from closing.

The lock edge of the door should be jointed a little under so that it will clear the frame easily. It is quite a general rule among carpenters to fit the face of a door so that a twenty-five-cent piece will just slip into the joint all around it. After the door is fitted satisfactorily, it is ready for the lock.

The *loose-pin butt* (*a*, Fig. 33) and the *loose-joint butt* (*b*) are the types of hinges generally used. The latter has

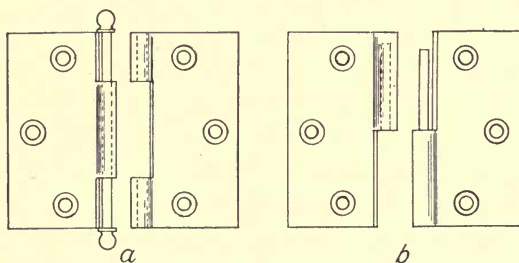

FIG. 33.— *a*, LOOSE-PIN BUTT; *b*, LOOSE-JOINT BUTT.

an advantage over the former in the ease with which a door may be removed and replaced, though some trouble may be caused in keeping the right and left hinges separate. The terms "right" and "left" as applied to hinges and locks refer to the direction in which the door swings when it is *pushed* open.

Also there are several forms of spring and special hinges, which are for use upon doors swinging both ways, or self-closing. Hinges should be set so that the door will swing wide open without touching the finish, as shown at *z*, Fig. 32. The pins of all the hinges should be upon the same vertical line.

Hinges for cupboard doors and other com-

mon work are often cut entirely into the door, as at *a*, Fig. 34; but upon the best work they are halved into both the door and the casing, as at *b*.



FIG. 34.—CUPBOARD HINGES.

35. Fitting locks. — (A.) The *rim lock*, shown in Fig. 35, is less expensive than a mortise lock, and as it may be put on very easily, is used upon the cheapest work. If the door rattles, the striker or latch plate (*a*) may be set back into the frame, or the lock itself may be set out by means of pasteboard or thin wood between it and the door.

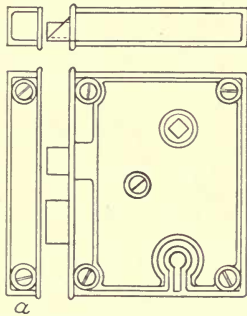

FIG. 35.—A RIM LOCK.

Padlocks are useless unless the hasp and staple by which they hold the door are fastened firmly in the wood; if padlocks are to be exposed to

dampness, those should be selected which have brass or bronze tumblers, otherwise they will rust so badly as to be worthless in a little while.

(B.) To fit a *mortise lock* (Fig. 36), bore a $\frac{3}{4}$ " hole for the knob spindle, as at *a*, and a $\frac{5}{16}$ " hole at *b*, for the key, being sure that they are accurately located before boring.

The mortise should then be marked, and "beat out"

or cut out with care, so that the sides of the mortise shall be parallel with the sides of the stiles of the door. No more wood should be cut out than is necessary, as the door stile may be weakened.

Put the lock in the mortise and mark around the face plate with a sharp knife; remove the lock and cut to these marks carefully, just deep enough to allow the face of the plate (*c*) to come flush with the edge of the stile.

The striker (*d*, Fig. 36) should be located in the doorframe as in Fig. 37, which shows a cross-section at *f, f* of Fig. 36, so that the inside of the door (*e*)

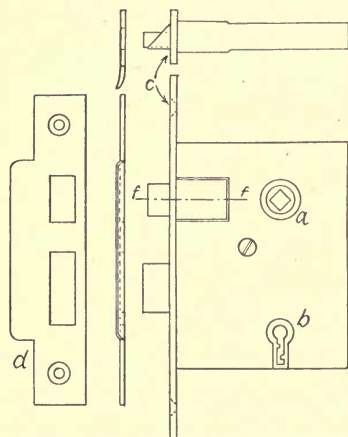

FIG. 36. — A MORTISE LOCK.

will be held closely against the rabbet of the doorframe at *b*, to prevent rattling. It should be placed at such a height that the bolt and latch will enter their places as near the vertical center of the hole as possible. It is important that the distance *c* should be the same both in the door and in the rabbet, otherwise the latch will not enter the striker, or the door will rattle. Be sure that the wood is cut away so that the latch and bolt will enter the openings in the striker easily.

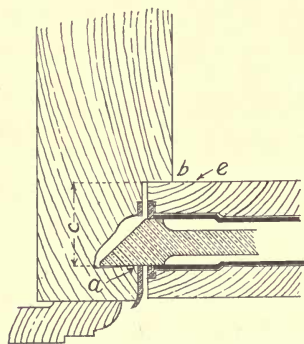

FIG. 37. — PLACING THE STRIKER OR LATCH PLATE.

Usually both rim and mortise locks are reversible, that is, their latches may be changed to suit either a right or left hand door.

Cupboard locks are usually screwed to the inside of the door.

36. The threshold.—In cutting down a threshold, considerable skill is necessary to make a good job. Figure 38 shows the different steps of the process. Drive nails in the floor at *a, a*, opposite each side of the doorframe, at

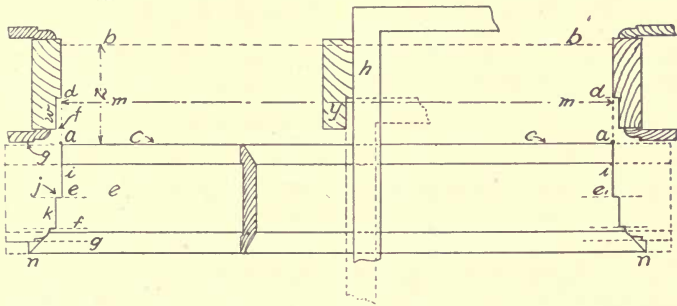

FIG. 38.—CUTTING DOWN A THRESHOLD.

exactly the same distance from each rabbet (*d*), and far enough from the plinth to allow the threshold to be moved endways without touching it. Mark lightly upon the floor the line *b, b*, the edge of the threshold when it is in place; this line should be parallel with the threshold when the edge *c, c* of the latter is resting against the nails *a, a*. The distance (*z*) between *b* and *c* should be taken with a pair of dividers, and with one leg touching the rabbet (*d*) make lightly a short scratch at *e* upon the threshold, marking the other end also. Without changing the dividers, lay off the same distance from the jamb (*f*) and from the face of the plinth (*g*), as these denote what will

have to be cut out to allow the threshold to go back into its place.

Do not use the try-square to lay out the ends, as they should be made to fit the horizontal section of the door-frame, which is rarely set perfectly square with the faces of the partition; therefore the cuts may be made with a knife at the angle of the jamb, which is found by using a straight-edge, or by the blade of a steel square, as shown at *h*. The square is in position to obtain the first cut (*i*) which is from the rabbet (*d*) to the edge of the threshold (*c*). Upon the line, *e*, of the threshold, lay off the exact size of the rabbet (*d*); measuring from *i*, mark *j* with the point of a sharp knife. With the steel square held against the long side of the rabbet, as indicated by dotted lines at *y*, move the threshold until the point, *j*, coincides with the edge of the square. Draw the line, *k*, which will rest against the long side of the rabbet at *w* when the threshold is in place.

Following the above method, make all marks necessary for the fitting of that end of the threshold. The length of the threshold is found by measuring the exact distance between the two jambs, from *m* to *m* opposite, and by laying it off upon the threshold from the cut, *i*, to the corresponding cut upon the other end. This should be a little long, not a measurable distance, say a little less than $\frac{1}{64}$ " in order to be forced to a close fit. Having obtained this point, proceed in the same way as in marking the first end, moving the threshold so as to make the points of length coincide with the straight-edge when held against the members of the doorframe which are to be fitted by corresponding members of the threshold, as described above.

All cuts should be made a little under, that is, shorter on the back or under side than on the face, so that the threshold may be forced into its place without marring the jamb. The outside ends of the threshold should be returned upon themselves, as shown at *n*.

The result of the work will depend upon the care used, and while the process may seem intricate, if it is followed through carefully once, it will be found to be much more simple than it appears.

SUGGESTIVE EXERCISES

26. Are the doors in common use made to order? Why? Compare doweled and mortised doors. What sized dowels should be used? Describe a coped-joint door. How is a door forced together and the joints held? Why should coping be done before the dowel holes are bored? Describe the groove and how the panel fits into it. Why should a panel be narrower than the distance between the bottoms of the grooves?

27. Give the sizes of the doors most generally used.

28. Describe the three grades of doors. What should be considered in buying a door? Of what kinds of wood are solid doors made?

29. How should hardwood doors be made? Describe the process of their construction.

30. What governs the kind of wood of which doorframes are made upon the best work? What governs the width of the door jamb? What should be its thickness? How is a rabbet sometimes formed upon cheap work? How should this be done? Describe a veneered door jamb, and tell why it is necessary. Describe two ways of fastening doorframes together.

31. Compare the doorframes of a frame house and of a brick house.

32. What is the relative size of a doorframe, and the opening in the partition? Describe the process of setting a doorframe. What should be done where the hinges are to be fitted to provide a "hold" for screws?

33. Describe the process of jointing in a door. If the stiles of a door

are not perfectly straight, which side should go next the rabbet? What difference will it make if a carpet is to go over the threshold?

34. Describe the process of marking and cutting in a hinge. Compare two kinds of hinges. How far should hinges project from the finish? Why should not the stile be planed straight? Describe the different forms of hinges in common use. What is meant by the "hand" of a door? How are cupboard hinges usually cut in?

35. Upon what grade of work is the rim lock generally used? Describe the process of putting on mortise locks. How should the striker be put on to prevent the rattling of the door? What kind of padlock should be used in damp places?

36. What is the first step in cutting down a threshold? Should the marks for the cuts to fit the inside of the jambs be made perfectly square with the edges of the threshold? Is it necessary that a try-square be used for this purpose? Describe the process of finding the cuts which are parallel to the edges of the threshold. The cuts for the ends. Should the marks be made with a knife or with a pencil? Should the ends be cut square or under a little?

CHAPTER IV

WINDOW FRAMES AND SASH

37. Window frames.— Window frames for common work are made generally in localities where labor and power are cheap, are sent to the market “knock down” (K.D.), or in “shooks,” and nailed together at the building where they are to be used. The size of the window frame is governed by the size of the sash it is to accommodate. The width of a window frame is between the pulley stiles (*a*, Fig. 39), and the height is measured from the point where the outside of the lower sash strikes the sill or stool (*g*), or at the inside of the partingstrip (*h*), to the header (*j*), as from *b* to *c*, Fig. 39.

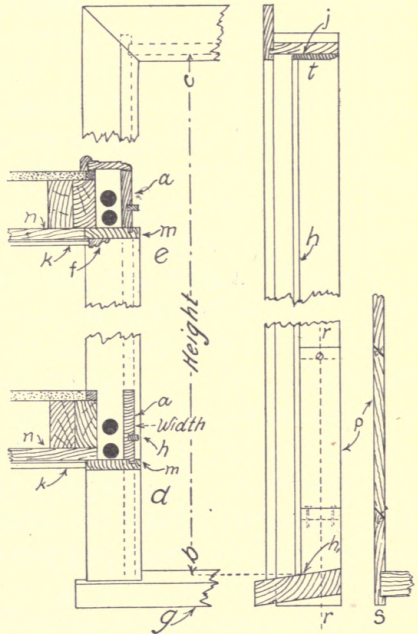

FIG. 39.—WINDOW FRAME WITH A SINGLE SILL.

There are a number of different styles of frames; those for common use are made usually after one of two

methods. The one shown in Fig. 39 generally is used upon the medium grade of work in the East, and has stood the test of many years of service in trying climatic conditions with perfect satisfaction. It has no subsill, and no blind stop, the blinds being hung upon the outside of the casing, as discussed later. Since there is but one sill, there is nothing to curl up and allow water to drive under.

As the clapboard, or siding (*k*), is generally thinner than that in common use throughout the West, a $\frac{7}{8}$ " outside casing (*m*) is all that is necessary to give sufficient sinkage to the siding. It is a cheaper frame to make than that generally used throughout the West.

Where this frame is in common use, it is quite the general custom to board the house upon the studding, and let the back of the outside casing (*m*) rest upon the boarding (*n*), cutting the siding (*k*) against it as at *d*.

To make a nice job, the frames are often set before the house is boarded in, with the outside casing (*m*) nailed to the studding, and the boarding (*n*) cut against it, as at *e*, Fig. 39. Before the frame is set, or while it is being made, a band molding (*f*) is mitered around the casing, $\frac{1}{2}$ " or $\frac{3}{4}$ " from the outside edge, and the siding (*k*) cut against it. In this case, the pulley stile (*a*) should be $\frac{7}{8}$ " narrower than if the frame were set as at *d*.

This makes a warm and a good looking piece of work, and is used often.

In making this frame, the pulley stile is grooved for the stool (*g*) upon a pitch of 1" in 7", and the stool nailed in, as at *s*. The bottom of the stile is cut off square with the edges about $\frac{3}{8}$ " below the stool at the outside edge; this gives a square base instead of a slanting one to rest the

frame on while handling or setting it. A piece known as the pocket (*p*) is cut upon the inside edge of each pulley stile as shown by section *rr*, at *s*, Fig. 39, for the purpose of allowing the sash weight to be removed easily. The pocket is afterward replaced, and fastened in with a screw at the top, and nails at the bottom, as indicated.

The parting strip (*h*) usually stops at the header, though a mortise is sometimes made there, to receive the top end of the parting strip. A wide stop bead (*t*) should extend from the inside of the upper sash to miter with the side stop strips; this is, however, part of the finish and not of the window frame.

The frame generally used throughout the West (Fig. 40) is a more expensive and finer looking frame than the one described above, but it gives no better satisfaction, as the subsill (*a*) is apt to curl up and allow water to drive under. The groove in the bottom of the sill of both frames is to receive the top edge of the siding. The pulley stile is sometimes cut off flush at the bottom of the subsill, as at *c*, and the sill (*b*) nailed upon the bottom of the whole frame, thus giving a slanting base upon which the frame must rest while it is being handled. Some manufacturers run the pulley stile down to the bottom of the sill, as indicated by dotted

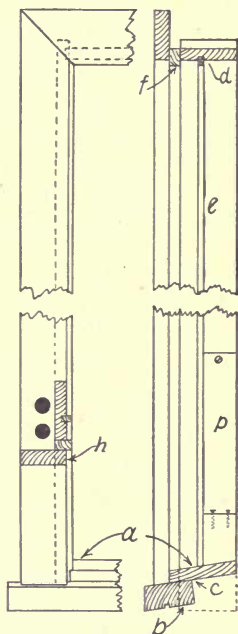

FIG. 40.—WINDOW FRAME WITH A SUBSILL AND BLIND STOP.

lines, grooving it to receive the sill as at *s*, Fig. 39. This makes a much better job.

The blind stop (*f*) and subsill (*a*, Fig. 40) add to the appearance of the frame, and allow the blinds to be

hung between the casings (*h*) which are generally $1\frac{1}{8}$ " or $1\frac{1}{4}$ " thick. Thick casings are necessary to allow the siding to be cut in and to prevent it from projecting beyond the face of the casing, as the siding generally is thicker than that used in the East, where a $\frac{7}{8}$ " casing is sufficient. In this type of window frame, the parting strip (*e*) is usually continued across the header, as at *d*. The pocket (*p*) is cut the same as in Fig. 39.

The outside casings of frames for wooden buildings are generally 4" or $4\frac{1}{2}$ " wide; this allows the frame to be fastened in its place by nailing through

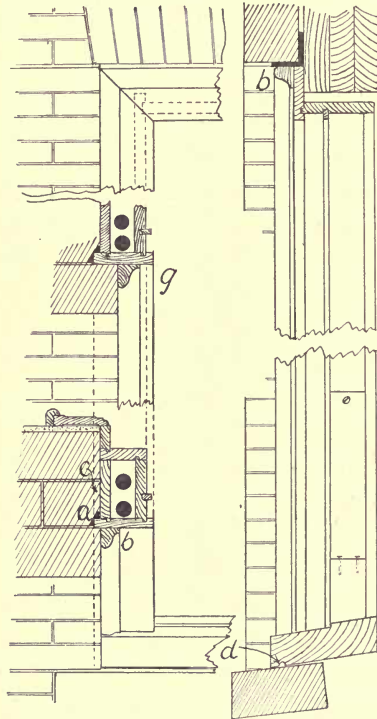

FIG. 41. — WINDOW FRAME FOR A BRICK HOUSE; A BOX FRAME.

the casing into the stud, upon which it bears one inch, allowing two inches between the back of the pulley stile and the stud, in which space the weight is to run.

A different form of construction is used in making the pulley stiles or boxes of window frames for a brick build-

ing, known as a box frame, Fig. 41. In this frame, the weights run in a box which is inclosed back of the pulley stile. The outside casing usually projects beyond the back of the pulley stile $\frac{1}{2}$ " as at *a*, Fig. 41, around which the bricks are laid, holding the frame firmly in its place.

The staff bead (*b*) generally is set about $\frac{1}{2}$ " from the back of the box, or the extreme outside of the frame, at *c*, and the brick laid against it as indicated, though sometimes as at *g*. Under the stool, as at *d*, is a groove which should be filled with cement when the frame is set upon the stone sill, thus preventing water from driving under. Aside from these distinctions there is no essential difference between the frames for a wooden and a brick building.

The architect often furnishes the details of the window frame and of the sash, and generally the only important point in which they differ from the ordinary stock window frame, aside from the specially designed moldings, is in the sill, as at *a*, Fig. 42, and in a drip upon the bottom rail of the lower sash (*b*). The advantage is that water cannot drive under the sash, as it may in an ordinary window. If the water drives under the sash, it has access to the end wood of the stiles, and will in time cause them to decay.

Mullion frames, consisting of two or more windows in one frame, are frequently used. The mullion pulley stiles should be $3\frac{1}{2}$ " or 4" apart, or far enough to allow the two sets of the window weights to work freely, if hung sash are used. A stud is frequently set in the mullion to support the header of the opening. If this is done it

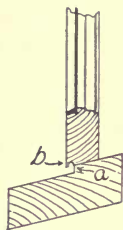

FIG. 42.—STOOL AND SASH WITH DRIP.

is plain that the backs of the mullion pulley stiles must be far enough apart to allow room for the stud and the two sets of weights. The header of the frame should extend the entire length between the end pulley stiles of the frame into which it should be grooved, the tops of the pulley stiles of the mullions being grooved into the underside of it.

The pulleys for all window frames should be strong and stiff, for if made of too light metal, they will wear out quickly, or heavy weights may spring them, thus allowing the cord to catch, causing much trouble and annoyance. The top of the pulley is usually placed 5'' from the under side of the header.

Frames for *casement windows* usually are made to allow the sash to swing out, as otherwise it is quite difficult to make them rain-proof. One objection to swinging the sash outward is that fly screens cannot be placed upon the outside of the window, though as they may be placed upon the inside, this is not a very important matter.

Window frames are often needed to accommodate *center hung sash*, which should swing with the lower half outward, otherwise the rain will be guided into the house. Sometimes sash are pivoted in the center of the top and bottom. This practice is not recommended for outside sash, as a rain-proof joint cannot well be made, though for inside work this method is quite satisfactory. A pin hinge is used for this, of which there are several forms upon the market.

38. Window sash. — The construction of window sash is practically the same in all parts of the country, though in some places the members are lighter than in others,

thus making it necessary that the frame and the sash should be of different sizes for the same size of glass, according to the style of sash used.

The names of the different members of a sash are given in Fig. 43. If the sash springs out of shape, it is difficult and often impossible to make it run smoothly, besides causing such a strain upon the glass that a slight jar may break it; therefore only the best seasoned stock should be used.

A sash should be made as light as possible, in order that the weight may be at a minimum and that the glass surface may be at a maximum.

The strength of a sash depends upon its construction at the corners, which should be made in the strongest way possible. Figure 44 shows the mortised, tenoned, and coped joints of the top and bottom rails.

The ends of the muntins are fastened to the rails by the same method. The tenon is split a little distance from the edge, as at *b*, or a saw cut is made by a thin saw, and a wedge (*c*) driven in, to make the tenon wider upon the outside of the stile than at the shoulder of the joint, thus forming a dovetail; the mortise is cut longer upon the ends to allow the split tenon to be pushed over. This should be done at each joint where a tenon comes through to the outside of the sash, though it is rarely done except

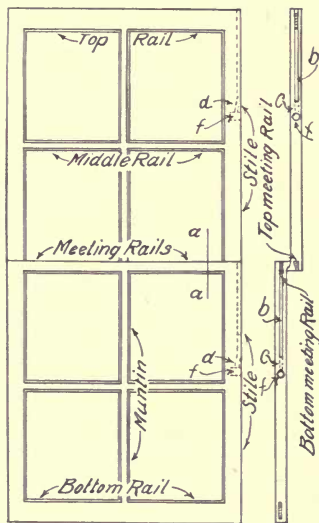

FIG. 43. — SASH MEMBERS.

upon the best work, or upon heavy sash. This is not the method in general use in the manufacture of common sash; commonly the tenons are pushed through, and the wedges driven between the ends of the mortise and the tenon. This gives fair satisfaction, and nearly all sash are made this way, as it is cheaper and easier. A hole is sometimes bored, and a pin driven through the mortise joint, and in large sash the joint is often draw-bored.

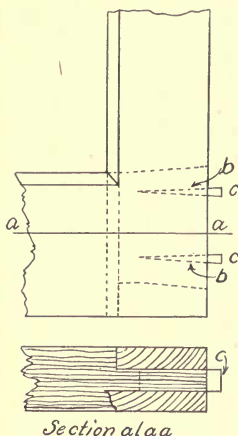

FIG. 44. — MORTISED AND
COPED JOINT.

The attention of the student is called to the joint between the meeting rails and the stiles (Fig. 45) as this has to stand hard usage. Most people in pushing up the bottom sash of a window lift under the middle of the top or meeting rail, and if the sash sticks a little, several heavy blows are usually given under it. In time, this will break the joint and destroy the sash; it may to some extent be prevented by using the strength as near the stiles as possible, working one side at a time, if the sash does not go up easily. To stand this usage the meeting rail is joined to the stiles by the dovetailed joint shown at *aa*, the strongest form of joint that can be used upon a sash of this sort.

A stronger form of sash than this is made, in which the stiles extend beyond the meeting rails about 3", as in Fig. 46.

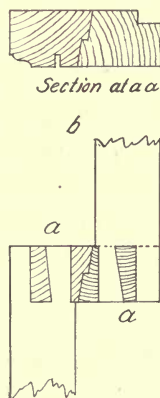

FIG. 45. — MEET-
ING RAIL JOINT.

This form of sash should be used where the greatest strength is necessary.

The edges of the meeting rails which form the joint between the upper and the lower sash are joggled and beveled; they should fill closely the space between the upper and lower sashes, as at *b*, Fig. 45, occupied by the parting strip, which will be described later.

A 1" hole, 1" deep, should be bored about 14" from the top of the edge of each sash as at *f*, Fig. 43, and a $\frac{3}{8}$ " groove $\frac{1}{2}$ " deep cut from near the hole to the top of the sash, as shown at *b*, *b*, leaving a space between its lower end and the hole, as shown at *c*. A $\frac{3}{8}$ " hole should be bored through *c*, from the groove to the hole, as shown at *d*, to allow a cord to pass through and to keep the knot in its place.

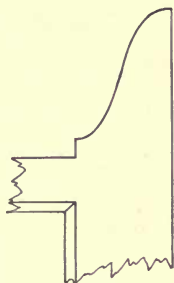

FIG. 46.—THE STRONGEST FORM OF MEETING RAIL JOINT.

When the sash are in place, the joint between the meeting rails is made tight by means of a sash fast, which pulls them together.

39. Glazing sash. — Glass should be cut about $\frac{1}{8}$ " smaller each way than the rabbet, to allow it to go in without forcing; it should be bedded before being laid in the rabbet. This is done by covering the part of the rabbet on which the glass rests with putty, as shown in Fig.

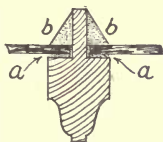

FIG. 47.—SECTION OF A GLAZED SASH.

47, *a*. In order to do this successfully, the putty should be as soft as it can be handled, for the glass has to be pressed into it until it bears evenly, and only about $\frac{1}{16}$ " of putty is left between the glass and the wood, as at *a*. This pressure should

be distributed lightly and evenly, therefore the necessity of soft putty. Another way of doing this, which is preferred by many workmen, is to roll a thin layer of soft putty upon a flat board; then by holding the glass at an angle, as shown in Fig. 48, a narrow strip of putty is taken off upon each edge as at *a*, and the glass laid in its place and carefully pressed down. This method can be applied only in a warm temperature,

as the putty chills quickly. When conditions are right, it is the best and fastest way of bedding glass.

The glass should be held in place by glazier's points while the putty sets. These are small triangular pieces of sheet metal which are driven into the sash with a chisel as shown at *a*, Fig. 49. The putty, as soft as can be handled, should be laid in and run down with a putty knife to the angle shown at *b* (also at *b*, Fig. 47), care being used that the putty does not project beyond the rabbet of the sash, so as to be visible from the other side.

If an old sash requires a new light of glass, the old putty should be cut out with a chisel, or if there is time, soften it with hot, soapy water, or some of the preparations made for the purpose of removing paint and putty, of which there are several upon the market. After the glass is set, the putty should be painted the color of the rest of the sash.

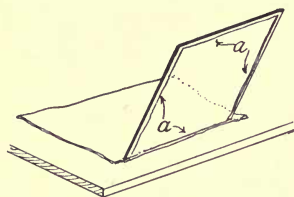

FIG. 48. — BEDDING GLASS.

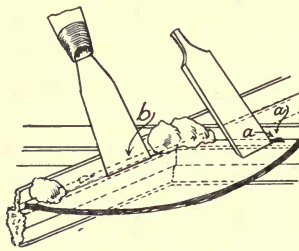

FIG. 49. — SETTING GLASS.

40. **Stock sizes of sash.** — Common sash are made in stock sizes in a variety sufficient for almost any purpose. These are determined by the regular sizes of glass, as the following list shows.

This list is for four-light windows, all $1\frac{3}{8}$ " or $1\frac{3}{4}$ " in thickness; it will be noticed that an allowance of 5" in width, and 6" in height, is made for the outside sizes of the sash, or the size of the frame, between the pulley stiles in width, and the stool and header in height at *b*, *c*, Fig. 39; if a different allowance is desired, it easily may be made.

SIZE OF GLASS	SIZE OF WINDOW	SIZE OF GLASS	SIZE OF WINDOW
10" × 20"	2' 1" × 3' 10"	14" × 26"	2' 9" × 4' 10"
10" × 22"	2' 1" × 4' 2"	14" × 28"	2' 9" × 5' 2"
10" × 24"	2' 1" × 4' 6"	14" × 30"	2' 9" × 5' 6"
10" × 26"	2' 1" × 4' 10"	14" × 32"	2' 9" × 5' 10"
10" × 28"	2' 1" × 5' 2"	14" × 34"	2' 9" × 6' 2"
10" × 30"	2' 1" × 5' 6"	14" × 36"	2' 9" × 6' 6"
10" × 32"	2' 1" × 5' 10"	14" × 38"	2' 9" × 6' 10"
10" × 34"	2' 1" × 6' 2"	14" × 40"	2' 9" × 7' 2"
10" × 36"	2' 1" × 6' 6"	14" × 42"	2' 9" × 7' 6"
12" × 20"	2' 5" × 3' 10"	14" × 44"	2' 9" × 7' 10"
12" × 22"	2' 5" × 4' 2"	14" × 46"	2' 9" × 8' 2"
12" × 24"	2' 5" × 4' 6"	14" × 48"	2' 9" × 8' 6"
12" × 26"	2' 5" × 4' 10"	15" × 24"	2' 11" × 4' 6"
12" × 28"	2' 5" × 5' 2"	15" × 26"	2' 11" × 4' 10"
12" × 30"	2' 5" × 5' 6"	15" × 28"	2' 11" × 5' 2"
12" × 32"	2' 5" × 5' 10"	15" × 30"	2' 11" × 5' 6"
12" × 34"	2' 5" × 6' 2"	15" × 32"	2' 11" × 5' 10"
12" × 36"	2' 5" × 6' 6"	15" × 34"	2' 11" × 6' 2"
12" × 38"	2' 5" × 6' 10"	15" × 36"	2' 11" × 6' 6"
12" × 40"	2' 5" × 7' 2"	15" × 38"	2' 11" × 6' 10"
12" × 42"	2' 5" × 7' 6"	15" × 40"	2' 11" × 7' 2"
12" × 44"	2' 5" × 7' 10"	15" × 42"	2' 11" × 7' 6"
12" × 46"	2' 5" × 8' 2"	15" × 44"	2' 11" × 7' 10"
12" × 48"	2' 5" × 8' 6"	15" × 46"	2' 11" × 8' 2"
14" × 24"	2' 9" × 4' 6"	15" × 48"	2' 11" × 8' 6"

Sash are spoken of as 2-, 4-, 8-, or more light; a hung window is composed of two sash, the upper and the lower. Thus in speaking of a window, a carpenter would say, "a 14 × 28, 4-light window," or "a 10 × 12, 12-light window," omitting the word "inches," as that is always understood.

To find the outside size of a sash, its different members must be estimated. To allow for any slight variation in cutting, or for the sash being out of square, the glass should have $\frac{1}{8}$ " play; that is, the opening for a 14 × 30 glass should be $14\frac{1}{8}$ " × $30\frac{1}{8}$ ". To this must be added the width of the stiles between the rabbet and the outside edge, and the width of the muntins between the rabbets; the same rule applies in finding the height of the opening.

Thus the outside dimensions of the sash of a 14 × 30, 4-light window, are 33" × 66".

Single sash may be described as being so many lights of a certain size, and to avoid mistakes, the size of the glass and the size of the outside of the sash should be given in an order, omitting nothing which will make the order plain.

41. Fitting a sash. — (A.) In jointing the sash to fit a window frame, the upper one should be fitted first, the edges being jointed so that the meeting rail will be as nearly level as possible. The edges of the lower sash should be jointed so that the tops of the meeting rails of both sash will be parallel in about the relation shown at *b*, Fig. 50; this distance should be taken with dividers and scribed off the bottom rail of the lower sash, as at either *c* or *d*. If a glazed sash is being fitted, it is obvious that the scribing should be done upon the inside of

the sash at *d*, before the stool cap of the window finish is nailed on, though it is equally plain that the best place upon which to scribe the bottom rail of an unglazed sash is upon the outside at *c*, as the inside, at *d*, will be out of sight when the stool cap is in place. A bevel should be set to the angle of the window stool with the pulley stile, and the bottom rail of the sash planed to fit it. The sash should be made to bear a little harder upon the outside than it does upon the inside, as at *e*, to prevent the water from driving under. When the sash are properly fitted, the tops of the meeting rails will be flush, as at *f*. The sides of the sash should be made to run easily, but not enough to rattle perceptibly.

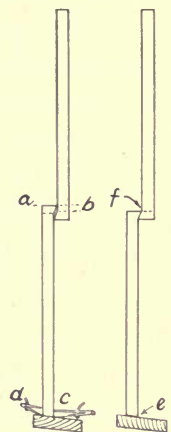

FIG. 50.—FITTING SASH.

(B.) Sash generally should be fitted and hung before the house is plastered; at all events before the finish is put up, as the house is thereby closed against the weather. Another advantage in hanging the sash before the finish is put on is that the cord may be pushed through the pulley from the window opening, and the weight tied on; the cord may then be cut and fastened to the sash without taking the pocket of the frame out, obviously an easier and more economical way than to hang the sash after the house is finished inside. If it is necessary that the house should be finished before the sash are hung, the weights are usually put in, and the cord run through the pulley from the back of the stile. A knot is then tied in it, so that it will not slip back, after which the sash may be put in at any time, as the cord is ready for it. This is not a desirable

thing to do, as the cord is in the way in jointing the upper sash.

If sash are not hung, nor the cord put in before the standing finish is put on, it will be necessary to remove the pocket of the window frame and to pass the cord over the pulley from the outside, and to pull it down to the pocket between the back of the pulley stile and the stud by means of a "mouse." This is a small weight which can be pushed through a pulley; it is often made on the job by tying a nail on a string, or by rolling a piece of sheet lead around the end of a piece of twine. After the other end of the twine has been tied to the end of the window cord which is to go through the pulley, the mouse may be pushed through the pulley and allowed to drop down between the stud and the pulley stile until it may be grasped by the hand through the pocket, at *p*, of Fig. 39. The weight is then tied on and pulled up to the back of the pulley; the sash is put in its place at the bottom of the opening in which it is to slide, and the cord cut off about 4" below the 1" hole in the edge of the sash at *f*, Fig. 43.

The end of the cord should then be pushed through the $\frac{3}{8}$ " hole (*d*, Fig. 43) and the knot tied, when the sash is ready for the stop strips which are to hold it in place.

42. Hotbed or skylight sash are made upon a principle entirely different from those in ordinary use, as they must be so constructed that water will run off easily. They are made to lay upon a pitch which should be not less than 2" to a foot. There are no middle rails; the bottom rail is thinner than the stiles or the top rail, the glass extending over it, so that the water will have no obstruction in its flow.

Upon sash of this description, the glass usually is lapped about 1" over the pane below, with no putty in the joint. It is bedded and puttied at the sides by the usual method, the glass being held in place by glazier's points, and prevented from dropping down while the putty is setting by means of a glazier's point bent to hold the glass or by a small brad driven in the sash be-

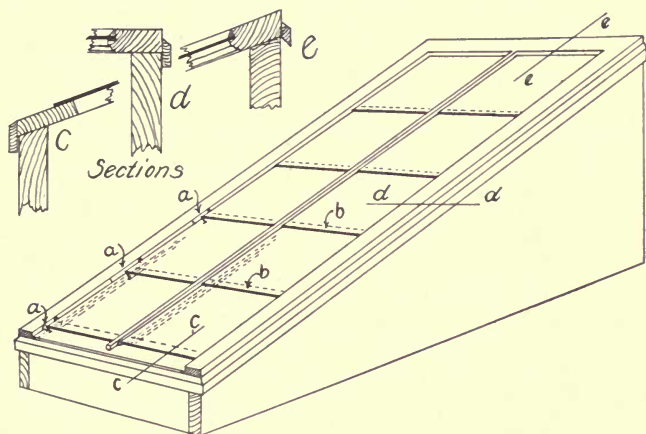

FIG. 51. — SKYLIGHT SASH.

low each pane of glass, as at *a*, Fig. 51. These brads or points should be driven so that the putty will cover them.

The sash for hotbeds and greenhouses need not be placed with so much care to prevent leakage as would seem necessary; the glass may be cut as square as possible, and laid end to end with a butt joint, instead of lapping as shown at *b*, Fig. 51; a strip is then screwed upon the frame of the sash to hold the glass in its place, as shown at *a*, Fig. 52. This eliminates all putty, and

allows repairs to be made easily, and the water which will leak through, if the glass is cut accurately, is insignificant.

In hanging a skylight sash, the joints should be made rain-proof by some method similar to that shown in Fig. 51, at sections *c*, *d*, *e*, in which strips are fastened upon the sash in such a way as to allow the sash to be lifted easily, but which will be water-tight when the sash is closed. The worst feature of a skylight is the condensation

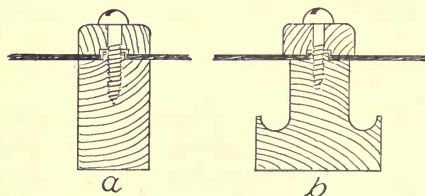

FIG. 52. — HOTBED GLASS FRAMES.

of moisture from the inside of the house upon it, the dropping of which is often mistaken for a leak. This may be remedied by an arrangement of grooves and gutters to carry the

condensation away and allow it to run out of doors upon the roof. This is not practicable nor advisable, unless there is a considerable area of roof to be treated, as in a dwelling house the skylights are rarely of a size which will make this an important matter.

There are patent forms of hothouse frames, similar to Fig. 52, *b*, which will care for the condensation of large areas of glass.

43. Store sash. — Sash for store fronts are of the same construction at the corners as other sash, except that the stiles and rails are heavier and should be put in place with the molded side out, instead of the puttied side, as in common sash. In store fronts large lights are sometimes held in place with a bead instead of putty, as in Fig. 53; this allows a certain amount of elasticity, as

the bead will spring and allow the glass to move a little, so that a strain, which would break the glass if it were held rigidly with putty, may do no damage.

If a large glass is broken, pieces may be left which would be of value if they could be removed safely, and the bead setting makes this possible. This method of setting glass has its disadvantages if the sash is to be exposed to the rain. This may be remedied by bedding the glass upon the outside with putty, or rubber tape.

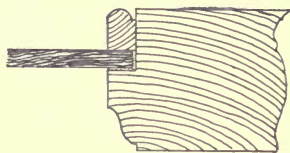

FIG. 53. — SETTING GLASS IN STORE WINDOWS.

Such bedding alone will not hold the glass sufficiently to interfere with removing it, if necessary, by simply taking out the bead from the inside of the sash.

In making glass doors which are to receive hard usage, the molded side of the door should fit against the rabbet of the doorframe, so that the weight of the glass will be against the wood instead of against the putty and points when the door is slammed.

44. Blinds are made in factories under the same conditions as are sash and window frames. They are ordered generally by the size of the glass, the same as sash. They usually are hung upon gravity hinges, which are so made that when the blind is swung past the center in either direction, it will swing the rest of the way itself, and will remain either open or closed.

Upon window frames which have blind stops, the blinds are hung between the outside casings, but if the frame has nothing but the casing outside of the pulley stile, the blinds are hung with special hinges. This latter is the usual method of hanging blinds in certain parts of

the country; in other places the gravity hinges are more popular.

SUGGESTIVE EXERCISES

37. Under what conditions are common window frames made? Describe and compare the frames in common use in different parts of the country. What should be the pitch of a window stool? What provision is made to allow the cord to be repaired? What is the difference between the frames of a wooden and of a brick building? How are the latter usually fastened in the wall? How is the joint between the stone sill and the window stool made tight? What is the principal difference between the frames for common and the best work? What is the advantage of the latter? What kind of frame is it that has two or more windows in the same frame? What is the objection to pulleys made of light metal? How should the sash in a casement frame swing? Why? How should a center hung sash be hung? Should a pivot hung sash be used for an outside window?

38. What is the chief difference in the construction of the sash in different parts of the country? Name and describe the different members of a sash. What kind of stock should be used in the manufacture of sash? What is apt to happen if the sash springs after the glass is set? Describe the joint used at the top and bottom rails of the sash. What is the best method of wedging the tenons of the mortise joints? Describe the joint of the meeting rails. Describe the form of sash which does away with the weakness of the ordinary sash at the meeting rail. What should be done to a sash to prepare it for the cord?

39. How should the size of the glass compare with the size of the rabbet? How is glass held in place until the putty sets? What should be the condition of the putty used in setting glass? Describe bedding a sash. How should a job of glazing be finished?

40. What is the basis for estimating the size of a sash? How does the carpenter speak of the size of a sash or window? How is the outside size of a sash estimated? Should the glass be the same size as the rabbet?

41. Describe the process of hanging sash before the building is plastered. What is the advantage of doing this?

42. Compare a hotbed or skylight sash with the ordinary form.

How is glass for hotbeds and greenhouses often laid and held in place? What is the most objectionable feature of a skylight sash? How may the trouble be remedied?

43. Describe the construction of the sash of a store front. What is the safest way to set a large glass in an inside frame? Compare the value of beads and putty for setting large glass. Upon which side of a glass door should the glass be set? Why?

44. What is the basis for ordering blinds? What kinds of hinges are generally used?

CHAPTER V

STAIR BUILDING

45. **Making measurements.** — The principal dimensions to be ascertained in measuring for a stairway are the *rise* and *run*. The term *rise* denotes the extreme height between the top of the lower floor and the top of the floor above, or the actual distance to be mounted in going from one floor to another; the term *run* refers to the horizontal distance which the treads must cover. It depends upon the size of the riser and of the tread whether or not an “easy” flight of stairs may be built.

Usually in localities where there is considerable building in progress, there are men, called stair builders, who make a specialty of this part of house construction, and who can do the work more cheaply than can the ordinary all-round workman. It is their custom to measure the building for the stairs after the floor joists are in place, as then there is less liability for mistakes. In fact, this custom is followed in every case possible in getting out any kind of finish.

A carefully dimensioned sketch of the stair opening is made, and the headroom calculated at the building, if there is any doubt as to the possibility of constructing a satisfactory stairway. This sketch should include the arrangement of the treads, platforms, landings, winders, and all dimensions necessary to enable the material to be prepared accurately at the shop.

46. **Laying out stairs.** — For an example of the method of laying out a flight of stairs, we will imagine a room 8' in the clear between the floor and the plastered ceiling, as in Fig. 54. Allowing the plaster and laths to be $\frac{3}{4}$ "

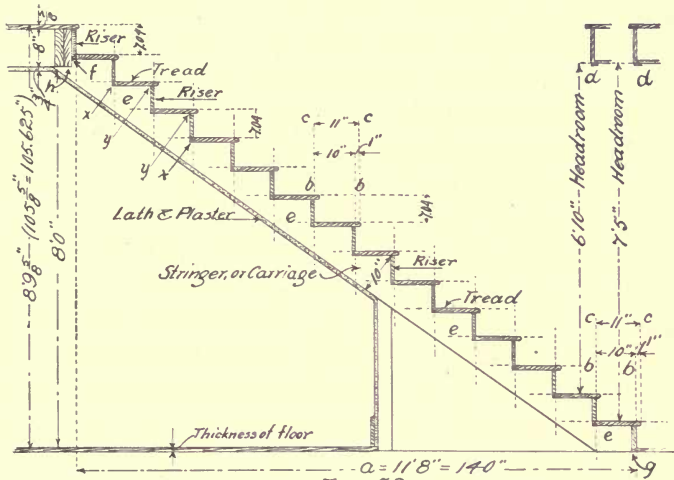

FIG. 54. — METHOD OF LAYING OUT A STAIRWAY.

thick, the floor joists 8'' thick, and a single matched floor $\frac{7}{8}$ '' thick, the entire rise of the flight will be $8' + \frac{3}{4}'' + 8'' + \frac{7}{8}''$, which is $8' 9\frac{5}{8}''$, or $105\frac{5}{8}'' = 105.625''$.

In order to find the exact *height of the riser*, which is usually the first part of the stairs calculated, we assume that 14 risers will be necessary to make an easy ascent; therefore the height of each will be $105.625 \div 14 = 7.54''$, or a little more than $7\frac{1}{2}''$. This rise may be satisfactory for a flight of stairs which has to be crowded into a small space, or where economy of space is necessary, but as it is desirable that the height of a step should be less than that, we will allow 15 risers to be used; therefore, the

height of each will be $105.625 \div 15 = 7.04''$, which will make a much better rise.

The height of the riser being found, the next thing is to find the *width of the tread*. If a straight run or a straight flight of stairs is being built, the horizontal distance between the starting and stopping points (a , of Fig. 54) may be divided into any number of treads; but if the flight has either a platform or winding treads, a plan should be sketched showing the location of the face of each riser, as in Fig. 55. A tread may be of any width sufficient to allow the foot to rest upon it safely, and the riser of any desired height not too high to reach easily by lifting the foot, but experience has shown that a certain range of proportions gives the best satisfaction. One method, as simple as any, of finding the width of the tread to fit a certain rise, is to subtract the sum of two risers from 24; the difference will equal the width of the tread. Thus, $24 - (2 \times 7.04) = 9.92$, practically 10; the flight would be spoken of as a $7'' \times 10''$ flight. The width of the tread is between the riser lines, as at b, b ; to find the exact width of the board which is to form the tread, it will be necessary to add to this the projection of the tread beyond the riser line for the nosing or finish of the front edge of the tread, usually $1''$, as at l . Thus the board forming a $10''$ tread will actually be $11''$ wide, as at c, c, l , of the two lower steps.

Another common method of finding the width of the tread is to divide 66 by the height of the riser; thus, $\frac{66}{7} = 9\frac{3}{7}''$, or the width of the tread. The student will see that the two most common methods give different results, therefore we may make the applications of the above rules somewhat elastic, as circumstances demand.

Experience has shown that a rise of between 7" and $7\frac{5}{8}$ ", and a tread of from $9\frac{1}{2}$ " to $10\frac{1}{2}$ " will give a satisfactory flight of stairs for ordinary use. For public buildings, and where the stairs are to be used by children to a great extent, the risers should be not over 7" high, and the treads should not be more than 12" wide.

Figure 55 shows a place where a flight of stairs requires a platform and winders. It will be seen that there are 15 risers and 14 treads, as the upper floor takes the place of the top tread.

In planning a flight of stairs, the number of risers is the first consideration, as the number and height of these determine the width of the treads, which must not be too narrow, nor too wide

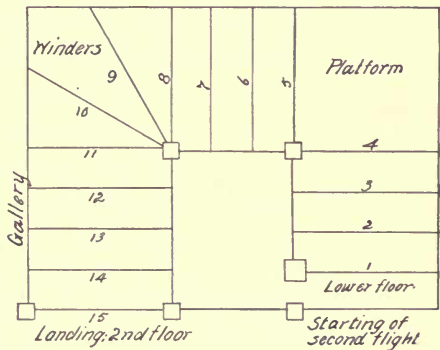

FIG. 55. — METHOD OF TURNING THE ANGLES OF A STAIRWAY.

for safety and comfort. In this case, though a platform would be desirable at both turns, it is plain that the two winders are necessary to allow the treads of the rest of the stairs to be of a satisfactory width. An extra tread could be placed in the lower run, but to have placed another tread in the upper run, which would have been necessary if a platform had been used, would have made each of the five treads in that run too narrow.

It is good practice to plan the winders so that at 18" from the post, they will be about the same width as the treads of the rest of the stairway; four winding treads will

be too narrow, and two treads in the winder would be too wide for safety and comfort.

47. Headroom. — It is necessary that judgment should be used in planning the headroom, or the vertical distance between the lower steps and the under side of the floor above (see *d, d*, Fig. 54), as any less than 7' 2'' will not allow a large piece of furniture to be moved from one floor to another without danger of defacing the wall. Though a headroom of 6' 6'' will allow a person of average height to pass without danger, any less than 7' 2'' appears cramped, and is inconvenient ; any more than this distance that can be allowed will add much to the appearance, as a roomy stairway gives the impression of spaciousness to the hall and to the whole house.

48. Stringers. — (A.) Stringers or carriages (*e*, Fig. 54) are the timbers or joists upon which the treads and risers are fastened, and as they support and give strength to the stairs, they should be made of lumber which is free from weakening defects.

Figure 56 shows one method of laying out a stringer. The full rise in inches is taken upon the tongue of a steel

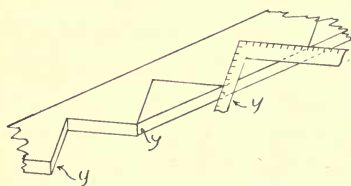

FIG. 56.—LAYING OUT A STRINGER.

or framing square, and the run or tread upon the blade, spacing off one tread at a time. If done with reasonable accuracy, this method is satisfactory for ordinary stairs, and where the head

or foot of the stringer can be moved a little to compensate for any slight inaccuracy ; but if intended for a place where a greater degree of exactness is necessary, another method should be used. The entire length of

the stair stringer should be laid out upon the piece, as between f and g of Fig. 54, which is the length of the stringer, regardless of the projection at h , which furnishes a nailing for the laths of the ceiling, at the same time making a stronger fastening possible. The angles and distances of x and y should be calculated carefully, and accurately laid off upon the stringer to be cut, the positions of the points y being averaged so as to make all the steps of the same size. This is the method in most common use. The length between the points f and g of Fig. 54, may be found mathematically by using the following formula:—

R = run of stringer, to g .

A = rise of stringer, to f .

H = hypotenuse or bridge measure.

$$H = \sqrt{R^2 + A^2}.$$

The pitch board, shown in Fig. 57, is preferred to the framing square by many workmen; it consists of a right-angled triangle of thin wood of the same dimensions as one of the steps, fastened to the side of another piece as shown. It is apparent that if the pitch board is used for the same purpose as the steel square in Fig. 56, it will be a convenience.

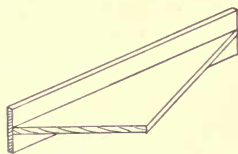

FIG. 57.—THE PITCH BOARD.

After the points of the stringer have been accurately laid out as described in the second paragraph of this topic, the exercise of a little judgment will make it possible to locate the intervening points y , of Fig. 56, so that any slight inaccuracies will not be apparent.

The pieces which are cut out of the side stringers may

be spiked upon the crowning edge of a piece of scantling, and used for the center string, instead of cutting another timber; in doing this, care should be used that the tread and riser lines are exactly in line with each other, which may be best assured by marking all by the first one made, working from points *y* of Fig. 54 and Fig. 56. The rough stringers are usually put in place as soon as possible for the convenience of the workmen.

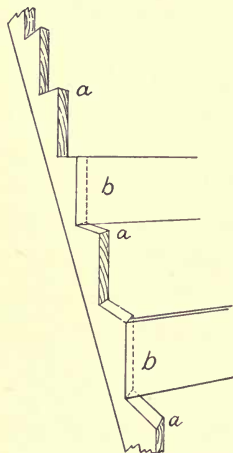

FIG. 58.—INTERSECTION OF RISERS AND FACE STRINGER.

If the face or outside string is to be of the same wood as the finish of the house, and is intended to take the place of the face casing or skirting board, the risers should be mitered into it, as shown at *a* and *b*, Fig. 58. Stairs built of this form of finish, that is, the ends of the steps open except at the balusters, are called an open string flight. The style is in common use, as it may be built as simply or as elaborately as desired. Upon ordinary work, the face stringer above described is the form in most common

use, but upon better work it is the custom to put the face casing on after the house is plastered, as it is apt to become discolored and marred before the stairs are ready for finishing.

(B.) The *skirting board* is sometimes fitted against the treads and risers, making a square joint, as shown at *a*, Fig. 59. The nosing is cut off, as at *b*, so that the skirting board may be more easily fitted. This method is used to some extent upon common work; the worst thing about

it is, that the seasoning of the building and of the skirting board will cause the joints to open eventually. It is a nice piece of work to fit the wall skirting board to the steps, but if done ever so carefully by the above method, the work will, on account of the shrinking of the material, in a few months look like a botch job.

Another method is to cut the skirting board into the treads and risers as shown in Fig. 60; the section *a, a* shows the groove which is continuous across both risers and treads, the nosing being cut out to allow the

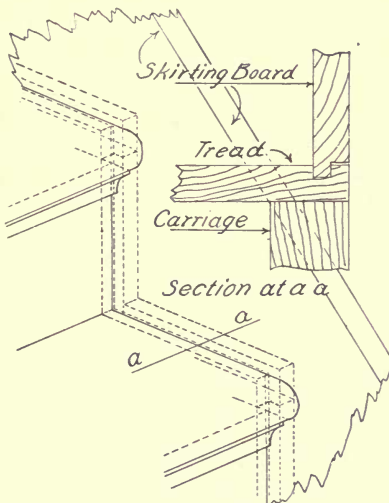

FIG. 60.—FITTING A SKIRTING BOARD; METHOD 2.

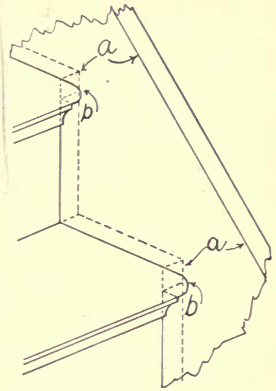

FIG. 59.—FITTING A SKIRTING BOARD; METHOD 1.

skirting board to fit between the end of the tread and the wall. This makes a very good job, and is a more economical method than that shown in Fig. 61, where the wall skirting board (*a*) is wide enough to receive the treads and risers, which are grooved, or housed in. A place is cut in the back of the vertical groove, as at *b*, and in the bottom of the horizontal groove, as at *c*, to receive the wedges (*d*), by means of which the tread

and riser may be pressed firmly into their places. This is the method commonly used upon the best work, and if the work is well done and of seasoned stock, there never will be any trouble from the opening of the joints, against which it is the first thought of the finished workman to

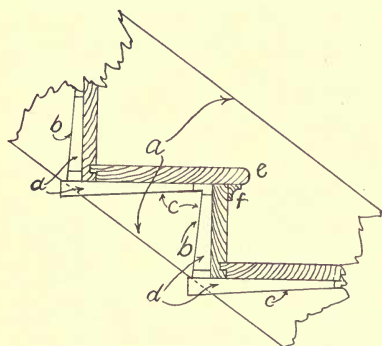

FIG. 61. — FITTING A SKIRTING BOARD;
METHOD 3.

guard. In this method, the nosing (*e*) and the scotia (*f*) both should be cut into the skirting board; however, the latter is sometimes butted against it.

In making attic and cellar stairs, and stairs in cheap buildings, a wide skirting board is sometimes nailed to the studing, and the treads and risers butted against it, supported by furring strips nailed to the skirting board. This method should be used only upon the most common work, since the joints are certain to open as the building seasons.

In building closed string, buttress, or curb stairs, the construction of which is illustrated in Fig. 62, the treads and risers are frequently housed into the wall string, or wall skirting board, as at *a*, and into the inside of the buttress, or face string, as at *b*, by the same method, and firmly wedged and nailed. The rest of the closed or buttress string is then built upon the inside piece, as at *c*. In constructing buttress stairs, the flight sometimes is built clear of any wall or other support, in which case the buttresses should be made of sufficient strength to support the flight and the heaviest load they ever will be

required to carry. If stringers are used, they should be far enough from the skirting board (*b*) to allow wedges to be driven which will force the treads and risers into their places, as illustrated in Fig. 61. If it is desired to build an economical flight of stairs of this type, a plank,

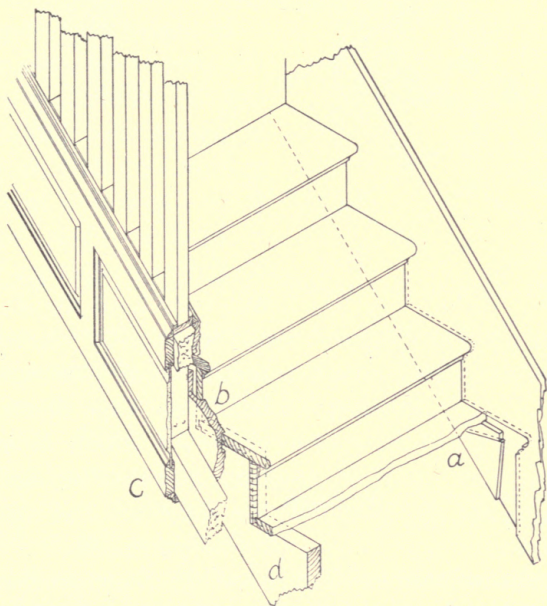

FIG. 62.—CONSTRUCTION OF BUTTRESS STAIRS; METHOD 1.

face stringer may be used, housed the same as the wall stringer, as indicated at *n*, Fig. 76.

Another method is shown in Fig. 63, in which the skirting board (*a*) of the face string is housed into the treads and risers; this is the stronger way, as the joints are less liable to open than if built by the other method, since the framework which supports the buttress, rail, and face casing

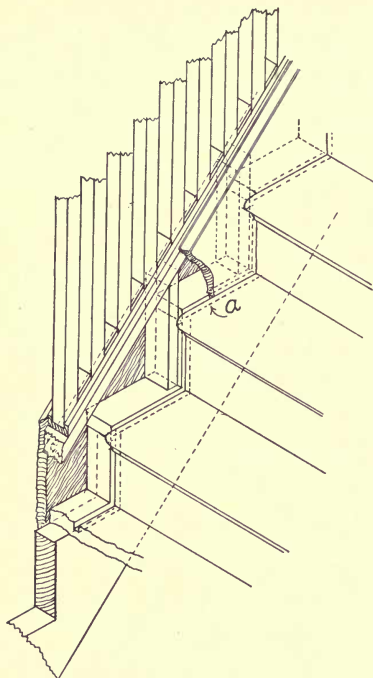

FIG. 63.—CONSTRUCTION OF BUTTRESS STAIRS; METHOD 2.

is fastened to the treads and risers. There are other methods of constructing a buttress string, but the two above indicate those ordinarily used.

In places where lumber of the proper dimensions cannot be secured, a stringer is sometimes built by a method similar to one of those illustrated in Fig. 64. A built stringer, however, is rarely satisfactory for any but very light flights.

Figure 65 shows two methods of fastening the heads, or tops of stringers, either of which is satisfactory, and may be used where the stairs are not supported by section posts.

49. Forms of stairs.—There are different forms of stairs which may be adapted to various shapes of stair openings.

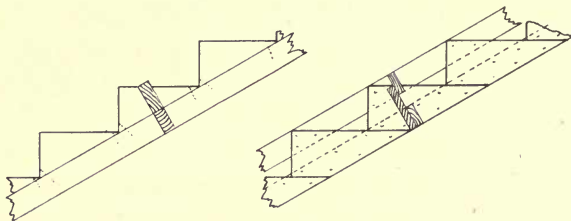

FIG. 64.—METHODS OF BUILDING STRINGERS.

The *straight run* (Fig. 54) has no turn, being straight from top to bottom, and is an inexpensive form of stairs to build. It is preferred upon common work for that reason, although a flight of this sort cannot be made so attractive as if it had an angle with a platform. It is less ornamental,

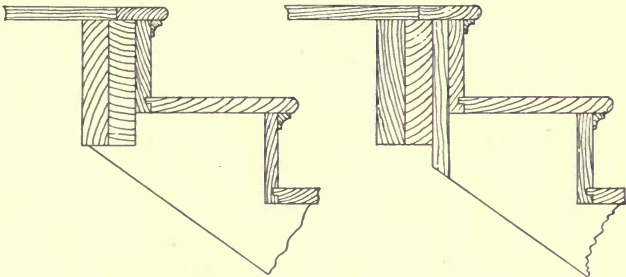

FIG. 65.—METHODS OF FASTENING THE TOPS OF STRINGERS.

and is used less than any other form, though in buildings where large crowds are to be accommodated the architect tries to secure a straight flight if possible.

A *platform flight* (Fig. 55) is a popular form, as it makes a safe and easy ascent. It may be made as ornamental as desired, and is frequently the center of the decorative scheme of an elaborate hallway. The figure shows a platform, illustrating all the turns of a full platform flight.

A *winding flight* usually is avoided as much as possible, as the narrow treads close to the post or rail cause many accidents, besides appearing small and pinched, as compared with the broad turns of a platform flight. A winding flight rarely should have more than four risers in the winding posts, though in attic or cellar stairs this is not observed, unless there is plenty of room. The upper half of Fig. 68 shows the plan; a full winding flight would make all of its turns by winders.

A *dog-leg flight* (Fig. 66) sometimes is used where it is necessary to economize in room and as wide a flight of stairs as possible is desired. The face string of the lower flight is directly under that of the upper flight, making an awkward place to receive the rail and balusters of the lower flight, since either they must stop under the face string of the upper flight, or there must be an easement to allow the hand to pass by, as at *a*. This makes the lower flight narrower. The rail therefore is frequently omitted between the place where the rail easement occurs and the post.

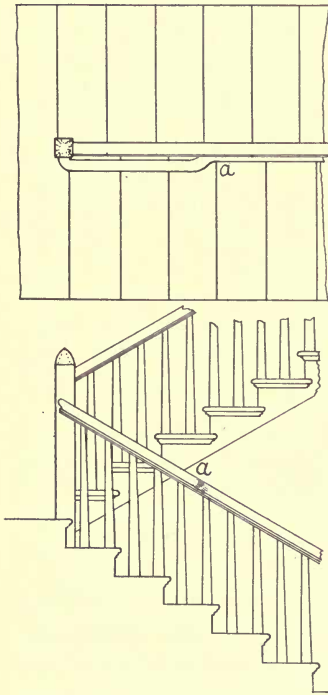

FIG. 66. — DOG-LEG STAIRS.

A *box flight* is built between two walls, and is the cheapest form of stairs to build, as there is no finish upon the outside, a skirting board being fitted against the steps at each side by one of the methods previously described, and a rail fastened to either one or both of the walls.

The method commonly used in framing the face string of stairs into the posts is shown in Fig. 67, where a finished face string (*a*) is used. A tenon is cut upon the end of the string to fit the mortise in the post, as shown at *b*. If the angle is turned by a platform, the risers (*c*, *c'*) are also mortised into the section posts, as shown at *d*, *d'*, the

top of the upper riser (*c'*) being the height of one step above the top of *c*. If the angle is being turned by winders, the risers, *c* and *c'*, are the lower and upper risers entering the section post.

Upon ordinary work the winding risers (*e, e'*), shown by dotted lines, usually are sawed to the correct bevel and nailed to the winding post; upon good work, and wherever the greatest strength is necessary, they should be tenoned into the section posts at the angle of their intersection, as indicated. These mortises should be placed so that the faces of the risers or face string will set back from the corner of the post the distance *g*, or enough to allow the nosing of the tread to stop against the post, and to bring the center line of the handrail and balusters in the center of the post. This distance will be governed partly by the projection of the finish of the tread, and principally by the size of the balusters, rail, and post. If a post $3\frac{3}{4}$ " square is to be used, the distance *g* will generally be about $1\frac{1}{4}$ ".

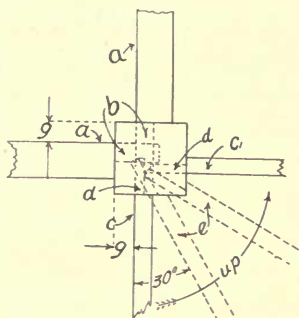

FIG. 67. — INTERSECTION OF CARRIAGES AND RISERS WITH THE SECTION POST.

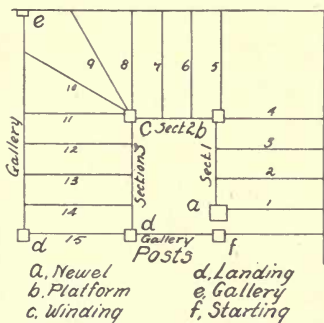

FIG. 68. — LOCATION OF STAIR POSTS.

50. Stair posts. — (A.) Stair posts are placed at the bottom, top, and angles of the stairs, as indicated in Fig. 68, the plan of a flight of stairs showing the location of

every stair post in common use. Figure 69 shows the method by which the squares receiving the carriages and rails are laid out.

(B.) The horizontal dotted lines denote the height of the risers, and the vertical dotted lines show the width of the treads; the points of intersection of these lines show the pitch of the stairs, with which the handrail is parallel, the angle of the pitch and the height of the handrail governing the vertical dimensions of the squares and turnings of the posts.

The *newel post* (*a*, Fig. 68) is located at the bottom of the flight, and is larger and more ornamental than the section posts, as it generally occupies a prominent place in the hall. The bottom square should extend 3'' above the top of the bottom tread and, if it is to receive more than one riser, the bottom end of the square should be enough longer to allow the risers to enter and leave the 3'' space above the top of the tread, the rest of the post being unchanged.

The *platform post* (*b*) is located at the angle formed by two short runs, a platform being the means of making the turn. It will be seen in Fig. 69 that there are three squares to this post, the two upper ones receiving the rails of the runs, 1 and 2, which form the angle in the stairs, and the lowest square receiving the carriages.

The *winding post* is shown at *c*, the bottom square extending high enough to allow it to receive the rail of the second section. It varies in length to allow the winding risers and the face stringers of the runs, 2 and 3, of the stairs to be mortised into it, the face of the stringer, or the face of the casing being kept back from the outside corner of the post $1\frac{1}{4}$ '', to allow the nosing or finish of

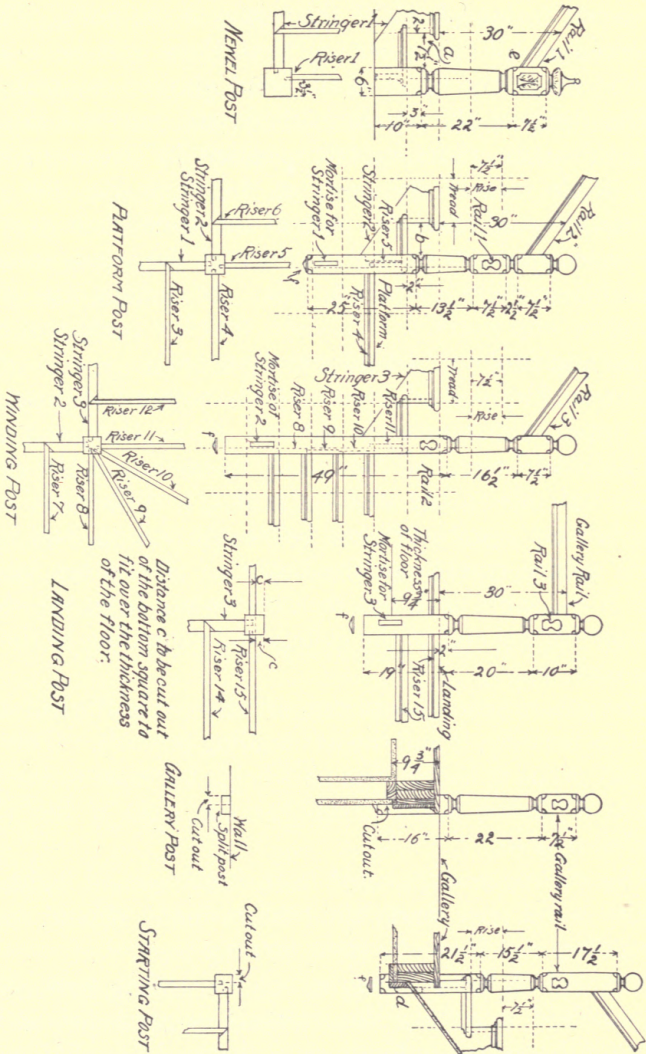

FIG. 69.—LAYING OUT STAIR POSTS.

the tread to land back of the corner of the post. This is observed in all the posts, so that there will be a place against which the finish of the steps may be stopped.

The risers of the winding treads are mortised into the bottom square, radiating from a point $1\frac{1}{4}$ " from the lower and inside face of the post, as shown in Fig. 69. The mortises should enter the post at the same angle at which the risers intersect it, the shoulder of the tenon upon the riser being upon the back side. In setting the posts, stringers, and risers, it is obvious that the posts and risers of the angles should be set simultaneously.

The *landing post* (*d*) is located at the head of the stairs; the upper square receives the rail of the third section of the flight of stairs, and the rail of the landing or the gallery which extends to the starting post (*f*) of the next flight. The bottom square extends below the ceiling, and is finished with a rosette on the bottom. The other landing post is the same as *d*, but receives no rail from the stairs; it supports one end of the gallery rail extending to the gallery post (*e*).

The *gallery post* (*e*) is to support the end of the rail which extends between it and the left landing post (*d*). This post usually is cut in halves, one part being fastened to the wall, where it makes a better appearance than if the whole post were used.

The *starting post* (*f*), used to start the second flight, just as the newel post starts the bottom flight, should receive the gallery rail from the right landing post, *d*.

(C.) All of these posts, except the gallery post, should be mortised to receive the stringers or carriages, and the joists of the gallery or landing; if the work is well done and the risers well fastened to the wall, the stairs will need no

additional support under the face stringer. However, unless there is another flight of stairs underneath, it usually is studded up for a closet.

Any stair post may be laid out by the above method, but in practice the builder will generally order his stair stock from the mill, or building supply house, or will have the stair-builder do the work. For ordinary work, the stock sizes of posts will be satisfactory, for by the exercise of a little judgment they can be made to fit stairs of almost any dimensions.

The squares of stock posts furnished by mills and supply houses are usually suitable for a rise of $7\frac{1}{4}''$ or $7\frac{1}{2}''$, these being about the average rises used for stairs.

The following table gives the vertical dimensions of posts which will, in most cases, be satisfactory; their locations are indicated upon Fig. 68. If a larger post is used, the squares should be lengthened, and the turnings shortened proportionately.

TABLE OF VERTICAL DIMENSIONS OF STAIR POSTS

KIND OF POST	SIZE	BASE	TURNING	SQUARE	TURNING	SQUARE	HEAD
Newel . .	6'' × 6''	10''	22''	7 $\frac{1}{2}$ ''	—	—	Any desired vertical dimen- sion.
Platform . .	4'' × 4''	25''	13 $\frac{1}{2}$ ''	7 $\frac{1}{2}$ ''	2 $\frac{1}{2}$ ''	7 $\frac{1}{2}$ ''	
Winding . .	4'' × 4''	49''	16 $\frac{1}{2}$ ''	7 $\frac{1}{2}$ ''	—	—	
Landing . .	4'' × 4''	19''	20''	10''	—	—	
Starting . .	4'' × 4''	21''	15''	17 $\frac{1}{2}$ ''	—	—	
Gallery . .	4'' × 4''	16''	22''	7 $\frac{1}{2}$ ''	—	—	

Concerning the sizes of the posts in the above table, it will be well to remember that a 6'' × 6'' post will be about $5\frac{3}{4}'' \times 5\frac{3}{4}''$, and a 4'' × 4'' post will be about $3\frac{3}{4}'' \times 3\frac{3}{4}''$ when they have been planed on all four sides, though the

usual way of speaking of them is upon the basis of their sawed dimensions.

If it is necessary that the base, or bottom square, of the newel post should receive more than one riser, or that the bottom square of the winder receive more than four risers, and the top end of the lower stringer or carriage, the aggregate height of the desired risers may be added to the length of the bottom square. If the angle included in the winder contains three risers, instead of four, the top of the bottom square should be lengthened the height of one riser, and the turning shortened an equal distance, to allow a landing for the top of the lower rail against the bottom square of the post.

The distance a of the newel post (Fig. 69) may be about the same as distance b of the platform post, though the newel post is sometimes set so that the bottom riser will come $1\frac{1}{4}$ " from the front of the post, instead of $3\frac{1}{2}$ " as indicated. This requires that there should be one less baluster upon the lower tread, and that the shaft of the post should be enough longer to allow the rail to land in the middle of the vertical height of the square. The dimensions indicated upon the table will generally be satisfactory, as the bottom square is often made somewhat longer than necessary, in anticipation of the necessity of adjustment and of scribing it to the floor. The height of the rail may be varied a little to allow it to come as near the middle of the square as possible.

The bottom square of a winding post, unless laid out for a certain place, should be about three inches longer than actually required, as any variation in the rise should be corrected at this place if possible, rather than by raising or lowering the rails sufficiently to make them perceptibly

out of pitch. The rosettes (*f*) should be turned separately, and nailed on after the bottom square has been cut to its exact length. This is the practice of many stair-builders, but others prefer to have the rosette turned on the post, and allow the bottom square to extend as it will below the ceiling or stair stringer.

The bottom squares of the landing, gallery, and starting posts are usually so cut that they apparently extend through the floor. They are notched over the thickness of the floor, which includes the ceiling, floor joists, and flooring, to rest against the side of the floor joist or header, the bottom end of the post showing its full size, ornamented with a rosette, as at *d* of the starting post. It is the custom of some stair builders to face the thickness of the gallery landing or floor its entire length, and notch the bottom square of the posts as above described; however, the post rests against the facing instead of the facing being cut against the post; in this case, the post projects $1\frac{1}{4}$ " to receive the nosing and scotia of the finish.

Upon common work, the riser between the last tread and the floor level, and the facing of the thickness of the floor, are often cut in square between the posts with a simple butt joint, but in the better class of buildings they are mortised into the posts, the same as in the winder and platform posts. It is plain that the former method will be affected by any settling of the building, while by the latter, the joints will not open. The bottom of a post which extends down upon a plastered or paneled wall, or in a corner, should be finished as shown by the bottom square of the gallery post.

A turned post should be laid out accurately, or there may be trouble in making the rails, stringers, and risers join

it properly. Upon the best class of work, turned posts are rarely used, some simply designed square post being in much better taste, in which case the connections may be made more easily, the post being cut to length at the bottom end, when its length can be measured exactly at the building.

51. Treads and risers. — Different methods of putting the treads and risers together are illustrated in Fig. 70.

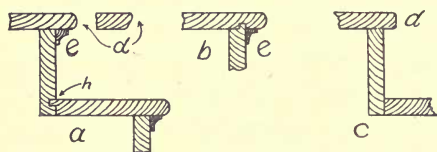

FIG. 70. — CONSTRUCTION OF TREADS AND RISERS.

The method shown at *a* is in common use upon the better class of work, as the tongue and groove joint between the tread and riser at *h* prevents dirt

from sifting through, and minimizes the effect of the shrinking of the tread and riser.

Some stair builders tongue and groove the riser into the tread above it, as shown at *b*, but the front edge of the tread is thereby weakened, so that when it is somewhat worn from rough usage, it will break off more easily than if the groove were not there. The cheapest form of construction is shown at *c*, all of the joints being square, with no grooves. This form is suitable for the cheapest class of work only.

The forms of moldings or nosings in common use for finishing the edges of treads are shown at *d*, Fig. 70, and the scotia at *e*.

A method of embellishing the risers of a flight of stairs which is capable of either simple or elaborate application is illustrated in Fig. 71. This method requires that a distance equal to the thickness of the scroll should be cut

off from the shoulder, or from the plumb cut of the top of the stringer, and that the mortise in the post should be set back an equal distance, as it is obvious that the face of the scroll should be considered the face of the stringer, and the mortises in the posts made accordingly. This method differs from the plain miter only in the addition of the scroll, in cutting the shoulder of the stringer to allow the risers to come where they would if a plain stringer were used, and in fitting a piece the same thickness as the scroll to prevent a hole between the face of the stringer and the back of the nosing (*b*). The risers and treads should of course extend to the outside of the scroll. The nosing, or the finish of the ends of the tread (*b*), is a separate piece, mitered into the front edge of the tread at *c*; the scotia (*d*) is mitered around the scroll at *e*. The back end of the nosing (*b*) should be returned upon itself in its proper relation with the scotia (*d*) and the bottom of the scroll of the riser above, which should be designed with this in view.

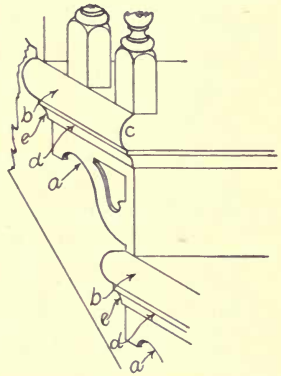

FIG. 71. — A METHOD OF FINISHING THE ENDS OF TREADS, AND OF MITERING A RISER AND FACE SCROLL.

A single piece of molding consisting of the nosing and scotia is sometimes used upon cheap work, as the end finish of the treads. In this case the ends of the treads are cut off flush with the face stringer, the front corner being mitered to receive the nosing of the end molding; the scotia under the front edge of the tread is then mitered in the usual way.

52. **Circular stair risers.** — A *circular stair riser*, illustrated in Fig. 72, is frequently needed, and one method by which it may be made is illustrated by Fig. 21. After the saw kerfs have been made, the riser is bent around a form and glued permanently, as at *a, b*, Fig. 72, and held in place by hand screws, as at *c, c* until the glue sets. The tread is fastened by nailing into the solid block (*a, b*).

A circling riser is sometimes built as shown at *b*, Fig. 72, the board being sawed, or planed thin enough to bend around the block (*e, f*). It is then glued there, being held

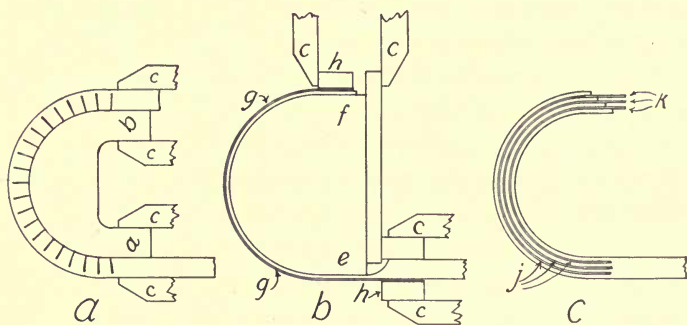

FIG. 72. — METHODS OF MAKING A CURVED RISER.

in place by a piece of sheet iron (*g*) which is fastened to blocks (*h*), and held in place by hand screws, as at *c, c*, until the glue is set.

Another method is shown at *c*, Fig. 72, in which the riser is resawed, as shown at *j*, and pieces of paper, pasteboard, or wood veneer (*k*), the thickness of the saw cuts placed in the cuts, and the joints filled with glue. The whole is then bent around a form, being held in place by some method similar to that illustrated at *b*. After the glue has set, the riser may be treated as straight. This

method may be used to make circular work of any kind, soffits, bases, etc., it being an application of the method explained in Topic 18, B. A curved board, made of thin pieces glued around a form, is the strongest kind.

53. **Handrails.**—There are many different designs of handrail, or stair rail, a few of which are shown in Fig. 73;

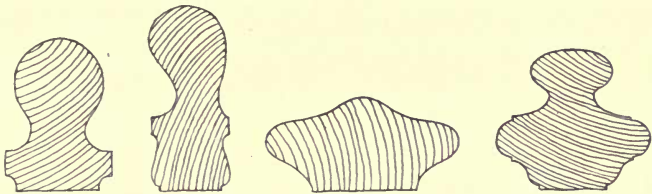

FIG. 73.—FORMS OF HANDRAILS.

only expense and individual taste can decide which is to be preferred, one of the principal considerations being the ease with which the rail fits the hand.

Figure 74 shows the usual methods of fastening rails to the posts,—*a* being suitable for use only upon the cheapest

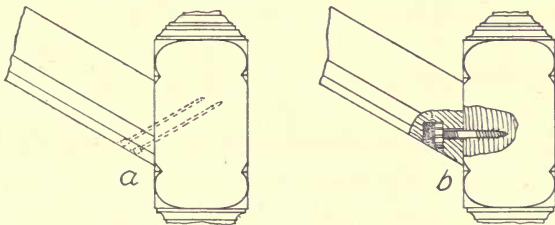

FIG. 74.—METHODS OF FASTENING HANDRAILS TO POSTS.

work and *b* indicating the best method for making a permanent job.

Sometimes it is necessary to splice a rail, though this should be done only as a last resort. If the long splice

method, shown at *a*, Fig. 75, is used, the point of the splice on the top of the rail should be pointed downstairs, and care should be taken to see that the rail is straight.

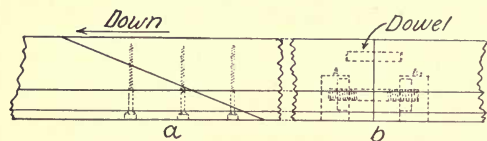

FIG. 75.—METHODS OF SPLICING HANDRAILS.

If the rail bolt method is used, as illustrated at *b*, Fig. 75, the rail should be handled carefully until it is in place, as a sudden twist or wrench may break the joint. The method shown at *a* is generally used on the best work. A splice always should be made as near the end as possible, and not in the middle of the rail.

The material from which handrails are made should be straight-grained and seasoned thoroughly, for if a rail springs after it is in place, the defect is difficult to remedy.

A handrail that is so long that it is not stiff enough sideways is often strengthened in the middle by a cast-iron baluster of the same design as the others, to the bottom of which has been added an angle-iron or brace, so that its bottom end may be set rigidly; the braces are covered by the finish. This baluster may be painted to match the rest of the stairs; if well done, its presence can be detected only by an expert.

54. Balusters. — Balusters are of many designs, suited to different styles of stairs, those with squares being used for the more expensive work. The balusters which are turned their entire length commonly are used upon stairs where economy is an object, though upon the best designed stairs a square, straight, or tapered baluster is frequently used.

Balusters are fastened to stairs by methods illustrated

in Fig. 76. At *a* is shown the method used in fastening square-ended balusters in the best open string work; they are mortised into the under side of the rail, as at *b* and section *k*, and dovetailed into the tread before the return or end nosing of the tread is put on. At *c* is shown the method by which the same style of baluster is fastened upon the cheaper grade of stairs; the top is cut at the

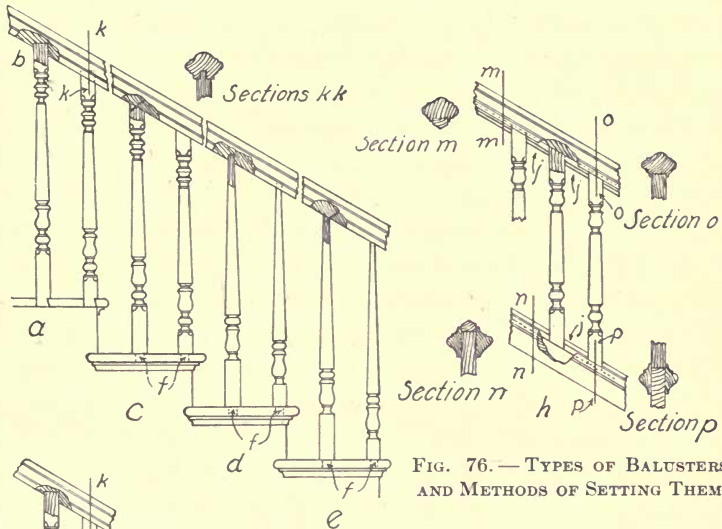
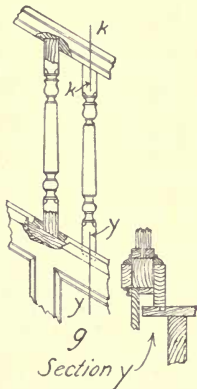

FIG. 76.—TYPES OF BALUSTERS AND METHODS OF SETTING THEM.



pitch of the rail and nailed, and a hole bored into the tread to receive the pin (*f*) which is turned on the bottom end of the square. At *d* is indicated the method by which round balusters usually are set upon the best class of work, and at *e* is shown a cheaper method, the same as method *c*, applied to round balusters. In methods *c*, *d*, and *e*,

the end finish of the treads (*b*, Fig. 71) should be in place before the hole is bored to receive the dowel (*f*).

In setting the balusters of a closed string flight, the tops and bottoms are sometimes treated as at *g*, though there is another method by which the balusters are set, as at *h*, the pieces, *j*, being fitted between the balusters at both the top and the bottom.

The lengths of the balusters upon most open string work are 2' 4" and 2' 8", as the top of the rail is supposed to be 30" from the tread, measuring from the riser line, and the same distance from the gallery floor.

55. Handrailing. — Laying out and making a wreath, or ease-off, or, as the process is called, "handrailing," forms one of the most interesting pieces of small work which the carpenter or stair-builder is called upon to do. The laying out of a wreath should be done upon a piece of thick paper or pasteboard, to be used afterward as a pattern.

Figure 77, *A*, shows the plan, or cylinder, or the top view of the outside of the wreath, which in this case is a quarter circle (*d*, *g*).

The lines extending to the right from *e*, *g*, and the center line, *f*, indicate the straight run of the rail joining the wreath. Draw the pitch line *K*, *M*, of indefinite length, found by a diagram of the tread and riser, as indicated by *K*, *L*, *M*, drawn at any convenient place, with *KL* parallel to the straight rail. Drop perpendiculars from *a*, *b*, *c*, *d*; mark point *N* at the intersection of the pitch line *KM* and the perpendicular dropped from *c*. Through *N*, draw *OP* parallel with *KL*; with *N* as the center, draw the arcs 1, 2; 3, 4; 5, 6; from 2, 4, 6, on *OP*, drop perpendiculars through the line *QR* (Fig. 77, *B*), which give the points of the ends of the top mold; transfer the

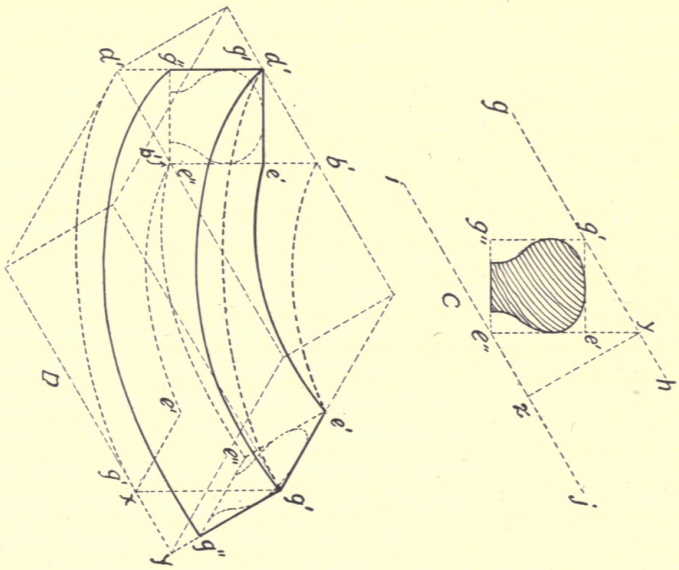
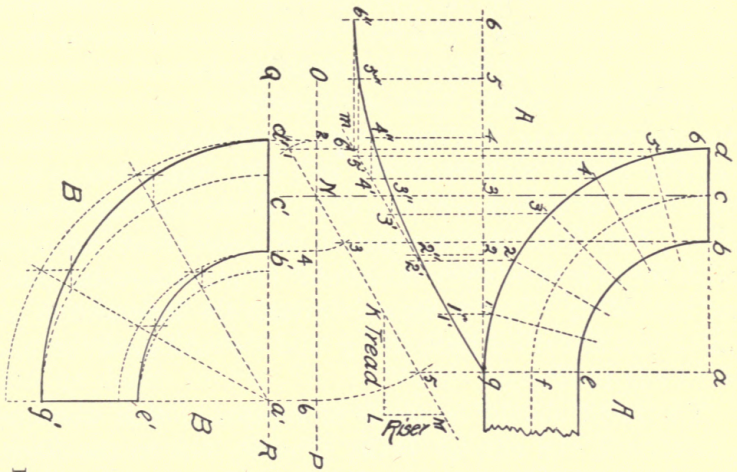

FIG. 77.—HANDRAILING.

distance a, e, g (Fig. 77, *A*) to a', e', g' , of *B*. The ellipses of the top mold, $d'g'$ and $b'e'$, may now be drawn by any method; that suggested is perhaps as convenient as any other. Three points upon an elliptical arc are ascertained by the following process: with a' as center, draw two quarter circles with radii $a'e'$ and $a'g'$, respectively, and one each of radius $a'b'$ and $a'd'$; trisect the right angle $d'a'g'$, and from the intersection of these trisecting lines with the four arcs, erect horizontal or perpendicular lines as indicated. Curves drawn through the intersection of these last described lines to $d'g'$ and $b'e'$ will give the desired elliptical arcs.

The mold should be made of a piece of thin wood or pasteboard, the ellipses being carefully cut to the lines. (Any plan of sweep may be drawn in place of the quarter circle a, d, g , of *A*, its pitch relation to the horizontal plane being found by the pitch diagram *K, L, M*.)

The next step is to mark the plank from which the wreath is to be made. The necessary thickness of the plank may be found by drawing a section of the rail and a square which will inclose it, as $g'e', g''e''$, Fig. 77, *C*; through g' and e'' draw the lines, gh and ij upon the same pitch as KM of *A*. The perpendicular distance between these, as at y, z , will give the thickness required. To find the length, continue $e'e''$ of *C* to y ; draw the perpendicular yz ; the distance $e''z$, plus the length of the top mold, $d'a'$, of *B*, equals the length of the piece. The width of the piece equals the distance $a'g'$ of *B*.

Lay the top mold on the plank from d' to g' of *D*, and mark around it; this will produce the upper pair of dotted lines $d'g'$ and $b'e'$. With a bevel set at the angle of the riser with the pitch line (KML , of *A*) mark the line $g'x$;

turn the plank the opposite side up, and place the angle g' of the mold at x , so that b' and d' on the bottom will be in exactly the right relation with b' and d' on the top of the plank, and mark around the mold, which will give the dotted lines $b'e'$ and $d'g'$ on the bottom.

Cut accurately both the inside and the outside of the wreath to the dotted lines $b'e'$, $d'g'$, thus obtained; do not cut the lines indicated by $g'x$, and $e'e'$, but allow the end at e'' , g'' , to extend its full length to y or beyond, as it will allow a square end to receive the straight rail.

For the side mold, draw the indefinite horizontal line $g6$, as shown in Fig. 77, A. Space the arc dg into any number of equal spaces, say six; transfer these to $g6$, a distance equal to the arc dg , or $g6$, by transferring the spaces 1, 2, 3, 4, 5, 6. Draw the indefinite pitch line of the arc gm from g , parallel to KM of B .

Drop vertical lines of indefinite length from 1, 2, 3, 4, 5, 6 of the arc dg , and where they intersect the pitch line gm , mark the points $1'$, $2'$, $3'$, $4'$, $5'$, $6'$. Drop indefinite vertical lines from points 1, 2, 3, 4, 5, 6 of $g6$, and draw a horizontal line from $6'$ of the line gm to the line which was dropped from 6, marking the intersection $6''$. Draw a line from $1'$ to 1 on gm , and mark the intersection $1''$. (This line will not exist, as the resulting curve is practically a tangent at this point.) Continue this process from $2'$ to $2''$; from $3'$ to $3''$, etc.

Connect points $6''$, $1''$, $2''$, $3''$, etc., with a curved line, which will equal $d'g'$ of D . Lay out the thickness $g'g''$ of the wreath parallel to line $d'g'$. After cutting paper or pasteboard to these lines, lay it upon the outside of the wreath as shown at line $d'g'$ of Fig. 77, D . This gives the outside top and bottom corners. Next lay out the squares

$g'g''$ and $e'e''$ upon each end, and proceed to cut to the lines thus obtained, keeping the top and bottom of the wreath square with the sides. If this is done carefully, the inside $e'e'$ and $e''e''$ of the rectangular form will be sufficiently accurate for the purpose.

After the rectangular form of the wreath is finished, mark the design of the rail upon each end, and with gouges and other convenient tools, work the rail to the shape of the one which it intersects.

The above is for a quarter turn stair, but if a circular, or winding flight is being built, the pitch line should be taken from the rise and run of the stairs directly under the center of the rail, which is also the center line of the balusters.

This may seem an intricate piece of work, but if it is once studied out carefully, and a wreath worked, it will be found to be a simple method for any one who can work accurately. In mills where there is a bandsaw, the piece from which the wreath is to be worked is held at the correct pitch by a jig, and the four sides of the wreath sawed. Upon ordinary work it is rarely necessary to work out a hand rail to special dimensions, as all that is needed may usually be found in stock.

SUGGESTIVE EXERCISES

45. What are the principal dimensions of a flight of stairs? What is the meaning of each of them? When should the building be measured for the stairs? When should the stringers or carriages be put in place?

46. Demonstrate the method of finding the rise of each step. The rise of the entire flight. How may a flight of stairs be planned, if a straight run cannot be used? Demonstrate two methods of finding the width of a tread. Between what points is the width of the tread? What is the common width of a 10" tread? Within what range of

dimensions for each step may a satisfactory flight of stairs be obtained? Is there any difference in the number of risers and treads necessary to build a flight of stairs?

47. What is meant by headroom? What is the least headroom allowable? What is desirable? In what way does a liberal headroom affect the appearance of a hall?

48. What are the timbers called which support the risers and treads? Demonstrate one method of laying out a common stringer. How should the stringers for an intricate flight be laid out? How may the length of a stringer or carriage be found mathematically? Describe a pitch board and its use. How may the pieces cut out of one stringer be used economically? How may the greatest degree of accuracy be secured in cutting a set of stringers? How should the outside or face string be sawed if it is intended to serve as the face skirting board? What is the advantage of not putting the face casing on until the house has been plastered? When are the rough stringers usually put in place? Describe three methods of making the wall stringer or carriage. Which is to be preferred for a first class job? Why? What is the cheapest way to build a flight of stairs? What are the objections to it? Describe a buttress flight. Describe two methods of building them. Describe other forms of stringers and carriages, and tell where they are used. Describe two methods of fastening the stringers at the top of a flight of stairs.

49. Describe a straight flight of stairs; its advantages and disadvantages. Describe a platform flight; a winding flight; a dog-leg flight; a box flight. Describe the method of framing the best stairs. In what way may the winding risers for an ordinary house be framed?

50. Demonstrate the method of laying out the squares upon a stair post. What governs the vertical dimensions of the posts? Describe the location of a newel post. How does it compare with the other posts? What should be the distance between the top of the tread and the bottom of the turning? Describe the platform post and its location. Describe the winding post and its location. How far from the face corner of the stairs should the mortises be placed? Why? From what point do the mortises radiate? Describe the landing post and its location; the gallery post; the starting post.

51. Illustrate and compare the different methods of putting together a step. What is the objection to grooving the front edge of a tread for

a riser? Describe different forms used in finishing the fronts and ends of treads and risers.

52. Describe different methods of making a circular stair riser. Which is to be preferred for a good job?

53. Describe two methods of fastening the rail to the posts. Which is the better way? Describe two methods of splicing stair rails. Which is the better method?

54. Describe two methods of fastening balusters in their places. Which is the better way? Describe and compare two methods of setting the balusters in a closed string stair. What are the usual lengths of balusters? From what point is the height of the rail measured?

55. Describe the method of laying out the top mold of a wreath. Describe the method of sliding the top mold along to mark the bottom of the wreath. Describe the method of laying out and marking the face of a wreath.

CHAPTER VI

PAINTING, HARDWARE

56. Painting is one of the most important of the trades with which the carpenter comes in contact, and it is the intention of this chapter, not to teach the carpenter to do the work of a painter, but to outline some of the facts which he should know regarding the common use of paint.

(A.) *In mixing* the priming coat, 100 lb. of white lead to 7 gal. of raw linseed oil and $\frac{3}{4}$ gal. of japan drier are the proportions commonly used upon the best work. After this first or priming coat has been put on, all nail holes, cracks, and other imperfections should be puttied; if this is done before the wood is painted, the putty is apt to fall out. For succeeding coats, 6 to 7 gal. of oil to 100 lb. of white lead will give good satisfaction; the drier is usually omitted after the first or priming coat.

Raw oil should be used upon outside work, as boiled oil does not stand so well, though a mixture of 3 parts of raw oil and 2 parts of boiled oil works more easily and dries faster, but is not so durable. However, it is used upon some of the best work. In many localities, boiled linseed oil is used entirely, but the work is not so permanent.

(B.) *Ready mixed paints* are used by some, but many of them are inferior to white lead and oil, or to white

lead, oxide of zinc, and oil, which are frequently specified upon the best work.

In using mixed paints, it is the safest plan to shun all makes which have not stood the test of time. Some ready mixed paints are hardly worth putting on; others will wear as well as the best white lead paint; in fact, the best brands of mixed paints are made of white lead, zinc, and oil, purchased and mixed in large quantities, under the most favorable conditions, and are generally superior to the white lead and oil mixed by the painter, both in spreading and wearing qualities. The price is about the same.

It is poor economy to purchase cheap paint, as paint costing 50 per cent more will often cover from 75 per cent to 100 per cent more surface than the cheaper kind, and give much better service under the same conditions.

(C.) *Knots* in pine and other pitchy woods should be covered with a heavy coat of brown shellac, to prevent the pitch from frying out.

(D.) *Metal work* should be covered with black varnish or asphaltum. Before being painted with oil paint, very rusty iron should be scraped and sandpapered to the clean iron. Boiled oil should be used, as raw oil requires so much time to dry that it is apt to be washed off by rain, or to catch the dust.

Upon metal roofs, iron oxide and boiled oil are about as satisfactory as anything which can be used, though there are many roofing paints of more or less efficiency made by different manufacturers.

A good roofing paint should be quick drying, of more body than is ordinarily used, should adhere closely to the roof without scaling, and should not blister in the sun.

(E.) Do not paint a *shingled roof*, as the paint covers only the exposed wood, and water which runs under the shingles of the course above will not dry out readily, thus causing decay and shortening the life of the roof. Shingles may be dipped in a creosote stain for about 9" or 10" from their butts before they are laid; this will act as a preservative to the shingles and increase their serviceableness.

(F.) *Wood adjoining masonry* should have a good coat of paint; this is not generally done except upon the best class of work.

(G.) *Wet or green wood* never should be painted, as the moisture in the wood is thereby confined and the result will be that either the paint will peel off or the wood decay, or both.

(H.) *Flat color* should be used upon inside work; this is made by mixing white lead with turpentine and a little varnish, together with the pigment necessary to give the desired color. If oil is used, the paint will turn yellow after a few months.

Instead of using a pure white paint, a little black should be mixed with it, or otherwise the white paint will be too glaring; this also prevents to a great extent the dingy appearance which a pure white has after the newness has worn off. Flat color is less transparent than oil color, and will, therefore, cover better, but it is not suitable for outside work.

(I.) It is often necessary *to remove old paint*; this may be done by burning with a gasoline torch, a method to be used only by a man of skill and judgment, as a fire is easily started while burning around places where the joints have opened and the wood is very dry. Old paint may be

removed quite well by using a preparation made of 2 oz. of soft soap and 4 oz. of potash mixed in boiling water, to which is added $\frac{1}{2}$ lb. of lime. Apply hot and leave it for 24 hours; wash it off with hot water.

Paint removers are made by paint manufacturers and sold at such prices that it is usually better to use them than to use any homemade mixture. They are generally quicker and surer in their action; some are apt to discolor the wood, but that is not an important matter, unless the work is to be finished in the natural wood.

(J.) In *finishing woods with an open grain*, as ash, oak, etc., it is necessary that the grain should be filled. Years ago this was done by applying several coats of shellac and rubbing each coat down to a surface with #00 sandpaper, or with pumice stone, but that method is very slow. Of late years the use of a paste filler has done away with the necessity of so much work.

There are several good makes of wood filler upon the market which are generally of the color of light wood; the addition of dry color will make it of almost any desired shade. If manufactured filler is not easily obtained, a fairly satisfactory substitute may be made by mixing cornstarch or whiting with turpentine or naphtha to form a thick paste, and by adding a little oil and japan to bind it together. Any desired dry color may be added after the paste has been thinned to about the consistency of cream by the addition of turpentine, or naphtha which is used by many for reasons of economy.

In applying the filler, it is not necessary to lay it smoothly, for when its surface has dried so that it resists slightly when rubbed with the finger, it should be cleaned off with excelsior or shavings by rubbing across the grain

wherever possible and by digging it out of the corners with a properly shaped stick and finishing with a soft cloth. Care should be used that the filler is not too dry or it will not rub off properly; if it is too moist, there will be too little left in the cells of the wood to fill the grain after the moisture has evaporated.

This filling may be applied to floors, standing finish, furniture, etc., of any open-grained wood after the filling has been brought to the proper shade or tint by the use of dry color.

(K.) For *finishing close-grained woods*, such as cherry, maple, birch, etc., the grain should be filled to prevent the finish from soaking in. This filling may consist of a coat of shellac, rubbed down, but there are substitutes in the market which are efficient and much cheaper and, for everything but the finest work, are perfectly satisfactory. These surface dressings usually are not intended for finish coats, as they will not stand rubbing, but simply for a surface upon which finishing coats of shellac or varnish are to be applied.

(L.) In *finishing floors* the nails should be set below the surface, and the cracks and imperfections thoroughly puttied; if finished in the natural wood, the pores and cells should be filled as above described, and the finish applied upon the surface thus prepared.

There are many good floor finishes upon the market, some of which are for finishing in the natural or stained wood, and others for painting the floors.

A good floor paint or finish should be tough, elastic, and able to resist the wear to which a floor is subjected.

(M.) Do not thin *shellac* with turpentine; alcohol or wood alcohol should be used for that purpose. Shellac

is a gum dissolved in alcohol and is used to give a fine permanent finish to woodwork. Orange or brown shellac should be used for dark woods, and white or refined shellac for all light colored woods, or where it is desired that the finish shall make as little change in the color of the wood as possible.

Considerable skill is needed in spreading it smoothly. It should be laid with moderately thick coats and rubbed down to a surface with #00 sandpaper, or pulverized pumice stone, after each coat. The last coat should be rubbed down in oil, and polished with a soft cloth. Though quite expensive, shellac makes a very satisfactory finish for a nice floor, if not exposed to water.

(N.) Do not thin *varnish* with alcohol, use turpentine. Varnishing always should be done in a room, the temperature of which is not less than 70 degrees; the room should be free from dust and drafts, and these conditions should be maintained until the varnish has set.

(O.) *Paint* and *varnish brushes* should be cleaned in benzine or turpentine; shellac brushes in wood alcohol; and if they are to be laid away they should be washed in warm soapy water, and rinsed in clean water. If paint brushes are to be used again soon, they may be hung in a vessel partly filled with water, so that the bristles do not touch the bottom. Shellac or varnish brushes may be suspended in a covered shellac or varnish pot.

57. Hardware. — The grade of hardware purchased for a house is generally in keeping with the kind of house being built, and is a fair index of the quality of the house throughout. However, expensive trimmings do not always indicate the true value of a house, because unscrupulous carpenters use them often with the purpose of deceiving.

(A.) *Wire nails* have but few points in their favor in comparison with *cut nails*; however, they drive more easily, are not so apt to split the wood, and as there are more in a pound, the original cost is less.

For the reason that wire nails do not resist the effects of moisture so well as do cut nails, the latter should be used for outside finish, though upon ordinary work this is not considered important, as the heads of the nails are painted, and are not exposed to the moisture so much as the nails with which shingles are fastened. If the best results are desired in shingling a house, cut nails should be used, especially in places near the salt water, where wire nails will sometimes allow the shingles to blow off a roof within three years from the time the roof was laid.

(B.) The *trimmings*, or the door knobs, window fasts, and other exposed hardware, should not be of plated ware, as the plating soon comes off. Brass or bronze trimmings are the best; bronzed iron trimmings are used upon common work where economy, rather than durability, is the object.

(C.) For *locks*, nothing is more secure than the time-honored bolt; our modern locks are simply applications of it, improved to meet modern demands. A lock which fastens automatically is called a spring lock, and one which has to be fastened and unfastened is known as a dead lock.

(D.) In putting on Yale or similar locks, the workman should follow the directions which usually accompany each lock. It is a good plan to set them back from the edge of the door a little, say $\frac{1}{16}$ " or less, to allow the door to be jointed at some future time if necessary.

(E.) Loose-pin and loose-joint butts or hinges are shown

may be removed for jointing more easily than if the loose-pin butt were used, and many workmen think that the loose-joint butts may be put on more rapidly.

SUGGESTIVE EXERCISES

56. What are the proportions used in mixing the priming coat of paint? How should all nail holes and cracks be treated? At what stage of the work should this be done? Why? What are the proportions for the succeeding coats? What kind of oil should be used for outside work? Why? Compare mixed paints with a mixture of white lead and oil. How should mixed paints generally be regarded? What is the best test? Compare the economy of using the cheapest and the expensive mixed paints. How should knots in pitchy wood be treated? What kind of oil should be used upon a metal roof? With what should metal work be painted? How should rusty metal work be treated before painting? What is a satisfactory roofing paint? What characteristics should a good roofing paint possess? Should a shingled roof be painted? Why? How should shingles be treated? How should wood adjoining masonry be treated? Is it a good plan to paint green or wet wood? Why? How should paint be prepared for inside work? Should a pure white paint be used? Why? How may old paint be removed? What is the objection to burning it off? What is the objection to some paint removers? How should open-grained wood be treated to prepare it for finishing? What was the old method of filling the grain? Why is that not necessary now? How may a wood filler be mixed? How should the filler be applied to the wood? How should it be treated afterwards? How are close-grained woods treated? What characteristics should a good floor paint possess? With what should shellac be thinned? How should it be laid? With what should varnish be thinned? What conditions are necessary for doing a good job of varnishing? Discuss the care of paint brushes.

57. What generally governs the grade of hardware purchased for a

house? Compare wire nails and cut nails. What kind of nails is best for use upon outside finish? Why is this considered unimportant? Why should cut nails be used to fasten shingles? What is apt to be the result if wire nails are used for shingling in a damp climate? Is there any objection to plated ware for the trimmings of a house? What kind of trimmings is best? Is a modern lock any more secure than a bolt? What is meant by a spring lock? A dead lock? Is it a good plan to set a lock exactly flush with the edge of the door? Why? Describe and compare the loose-joint butt and the loose-pin butt.

CHAPTER VII

ESTIMATING

58. Plans. — If work of importance is being considered, a contractor should always insist upon having a complete set of *plans*, a carefully prepared set of *specifications*, and a written *contract*, all so drawn as to insure against the possibility of a misunderstanding.

59. Location. — The contractor should be familiar with the location of the house and be thoroughly posted concerning the facilities for transportation and for obtaining material and help. He should know how far from the excavation the earth has to be carried and should have reliable information about the nature of the subsoil and the possibility of ledges and springs which might cause difficulty in making a dry cellar.

60. Method. — In writing the matter for this chapter, the plans of a house and its accompanying stock list and estimate have been purposely omitted, as it will be far better that the students or teacher should select a small accessible building, make a set of plans of it from actual measurements, and use these as the basis from which the estimates and the stock lists of the class should be made. In this case, the building can be used for the purpose of study and demonstration, thus giving the student the benefit of comparing his work with actual results.

By the approximation method¹ of estimating, the estimator works upon the basis that the use of a certain quantity of a certain sized material will accomplish a known result ; for instance, instead of counting the exact number of studs necessary to stud the wall of one side of the house, then of another, he measures the entire distance to be covered by all of the walls and partitions, and allows one stud to each foot, with an additional one for each angle and opening. Instead of figuring that a man can set a certain number of studs in a given time, the cost is found by figuring that it will cost a certain amount to set a thousand feet (board measure) of studs.

The estimate based upon the approximation method should be first worked out, followed by the stock bill from which the actual work would be done if the building was to be built. If the building which is being studied was built by contract, and copies of the contract and of the original stock bill could be secured, they would be of great value in criticizing the results of the work of the class.

A contracting carpenter may follow the safe method of getting estimates upon the different parts of the building which must be done by other workmen, then adding his own estimate; to this total are added the amounts for incidentals and profit, the sum of which is his bid for the contract. If he is awarded the contract, he treats the bid from each sub-contractor as a maximum, and tries to find a man who will do the work for a lower price. This method usually results in fewer contracts, but there is less risk

¹The term "Approximation Method," as used in this book, has no relation to the "Preliminary Approximation Method," which is based upon the cubical contents of a building and is principally used by architects in arriving at the approximate cost of a contemplated building.

than if the contractor depended upon his own figures entirely. It is impracticable to give here prices of labor and material, as they vary so that no list can be devised which will suit all localities and times; therefore we shall, in most cases, discuss only the time necessary for doing the work under average conditions, and the methods of estimating the materials, leaving the student to obtain the local prices. All estimates are based upon a day's labor of nine hours.

The contractor should not try to save too much time in estimating, but should aim at accuracy and safety, since this is as important as it is that the work is done well and economically.

NOTE. — In all estimates given, the student should not forget that they are based upon the actual cost, and that, for the estimate to be submitted, the profit is to be added to the total cost.

Whether he gets the job or not, the young contractor should keep a systematic and permanent record of all his estimates, the cost of material and labor, and any information he may think valuable; if he does the work himself, he should check his estimates when the actual results are known. This record will be found of great value in making succeeding estimates. A pocket size loose-leaf binder is a great convenience for the valuable data which is continually presenting itself.

In order to estimate successfully, there should be a schedule containing the items to be estimated. These should be considered one at a time to ascertain the necessary dimensions and quantities, after which similar items of the same price should be gathered together and the cost of the total quantity estimated as one item. The totals of these different items should be summarized, and their total

ascertained; to this should be added from 5 per cent to 25 per cent for incidentals, use of equipment, etc., and the same percentages should govern the amount to be added for profit. The grand total should be the amount of the bid.

61. Excavations. — Under the head of excavations, unless otherwise specified, should be included those for the cellar, piers under the partitions, porches, cisterns, cesspools, vaults, and trenches for the water and sanitary system of the house.

The excavated earth should be carried far enough away so that it will not interfere with the workmen, but if it is to be used for filling and grading around the house, work which is usually in the contract for the excavation, it should be carried as little distance as possible.

For a day's work, two men should excavate from 10 to 12 cubic yards of sand, gravel, or moderately soft clay, and carry it 60 feet in a wheelbarrow. Two men and the driver, with a horse and cart, should pick, throw out, and carry the same distance from 16 to 20 cubic yards of the same sort.

Filling in and grading around the house usually costs about a fourth as much as the excavating.

62. Stonework. — Masonry will be discussed under two heads, stonework and brickwork. The work of building the foundations, piers, chimneys, etc., is usually a sub-contract, and as such, the carpenter may have one or more masons figure upon the work and make their estimates the basis of his own, adding enough to reimburse himself for building the scaffolds, arch centers, and other work which the mason may require of him.

The items to be considered in estimating the mason-work of a building are as follows:—

<i>Walls</i>	<i>Settings</i>
Area.	Fireplaces.
Cesspools.	Furnaces.
Cisterns.	Hearths.
Foundation.	Range.
Outside.	
Partition.	<i>Miscellaneous</i>
	Arches.
<i>Material</i>	Chimneys.
Broken stone.	Cut stone.
Cement.	Footings.
Gravel.	Labor.
Lime.	Piers.
Sand.	Stone cutting.
	Tiling for drains.

The unit of measurement for stonework varies in different localities, cubic yard, perch, and cord being used. The following table will be found useful in estimating quantities.

27 cu. ft.	= 1 cu. yd.
128 cu. ft.	= 1 cord of uncut stone.
100 cu. ft.	= 1 cord of stone laid in the wall.
$24\frac{3}{4}$ cu. ft.	= 1 perch.
1 load of sand	= 25 bushels.
1 bbl. lime or cement	= $2\frac{1}{2}$ bushels.

In estimating the stone in a wall, it is customary to measure around the outside, thus reckoning the corners twice and allowing for the additional work and waste necessary to build them. This distance should be multiplied by the height and by the thickness of the wall in feet, the result being the quantity in cubic feet.

It is always wise for the contractor, before he sublets the foundation walls, to have an understanding with the mason, as usually local custom governs the measurements of openings. In laying a rubble wall, it is the common practice to measure all single openings as solid wall, as the extra work will make the cost about even. Of an opening larger than 16 sq. ft. a half usually is counted.

If the estimate is for stone in the wall, the price should be about a fourth greater, to allow for waste and extra work around openings.

One man and a helper should lay about $2\frac{1}{2}$ cu. yd. of rubble stone in a day, using 1 bu. of lime and $3\frac{1}{2}$ bu. of sand to each cubic yard of stone. If the stone is laid in Portland cement, it will require $\frac{1}{2}$ bbl. of cement and 4 bu. of sand.

One man and a helper should lay $1\frac{1}{2}$ cu. yd. of ashlar per day, or about 40 sq. ft. of 12" wall. The mortar with which it is laid will cost from 25¢ to 30¢ per cu. yd. of stone.

A stonecutter in a day should cut about 25 or 30 sq. ft. of bluestone or granite, rock-faced, pitched, random ashlar, with the beds straightened 3" back from the face; of coursed ashlar, the amount would be about a third less.

As the ashlars and rubble are the kinds of work commonly used, we will not discuss the more expensive and the less used tooled and draft methods of finishing stone.

63. Brickwork. — Under the head of bricklaying should be considered the items mentioned in connection with the preceding topic.

It is usual to measure a brick wall solid; however, in buildings where there are many openings, as in those of the slow burning or mill construction, in which about half of

the wall is occupied by windows, it is generally safe to deduct for the openings about 25 per cent of the wall area.

If estimated as above, it is not the custom to make any allowance for pilasters, arches, or any simple detail in the wall; if an opening occupies over 100 sq. ft., it is generally entirely deducted.

A square foot of brick wall contains $7\frac{1}{2}$ bricks, if the wall is two bricks thick it contains 15, and if the wall is 13" or three bricks thick it will contain $22\frac{1}{2}$ bricks to the square foot of wall surface. This is called a cubic foot of brick if estimated in the wall; if a large mass of brick masonry is being estimated, it is the usual custom to calculate that one cubic yard of brickwork will contain 575 bricks.

There is a loss by breakage and waste of 5 per cent, which should be added to the quantity estimated as being actually necessary in the building.

To lay 1000 bricks, it will take 3 bu. of lime and 12 bu. of sand; for pressed brick, it will need about $\frac{1}{2}$ of the above quantities, as the joints should be only $\frac{1}{8}$ ", while upon ordinary acceptable work they are $\frac{5}{16}$ " or $\frac{3}{8}$ ".

Under average conditions, a man should lay 1000 bricks a day, but upon some kinds of intricate work this amount may be reduced to 200 or less; if face brick are being laid, a man will lay only about a third as many as of the common brick.

64. Carpentry. — Under the head of carpentry we will discuss only the framing of a building, and its preparation for the outside finish, roofing, and lathing.

Some contractors make out a bill of the material as they estimate it, giving the dimensions for each piece as for the final list. This method has a high degree of ac-

curacy to recommend it, but as a piece of dimension timber must generally be cut from lengths of multiples of two feet, it is plain that the time spent in making such an accurate list is often wasted, as it is a very low estimator who is awarded more than one in five jobs on which he figures and for which there is much competition. The approximation method herein described is much quicker and the results will vary but little. (See Topic 60.)

For the purpose of subsequent checking and reference, a record should be kept of the quantities and dimensions included in the estimate.

The items which should be considered in connection with the framing of a building are as follows:—

Plan Members

Floor joists.
Girders.
Headers.
Plates.
Sills.
Tail beams.
Trimmers.
Trusses.
Under floors.

Elevation Members

Braces.
Corner posts.
Posts in cellar.
Sheathing for sides.
Stair stringers.
Studs.

Roof Members

Collar and tie beams.
Common rafters.
Cripple rafters.
Curb plates.
Hip rafters.
Jack rafters.
Lookouts.
Purlins.
Ridge.
Sheeting.
Shingles.
Valley rafters.

Miscellaneous

Bridging.
Furring and strapping.
Labor.

In estimating the quantities in the frame of a building, it is usual to select all of the rough lumber costing about the same, add the different kinds together, and estimate the aggregate at an average price.

Studs, if set 16" to centers, are counted one to each foot in the width of the walls and the partitions, and one for each opening and angle. This will give enough for gable studs, scaffoldings, and for various other purposes not included in any estimate. A more exact method is to calculate the width of the partitions and walls, to subtract a third of that amount in feet from the total, and to add one for each angle and two for each opening. The former method is the one in common use among builders.

In setting studding upon ordinary work, about 20 lb. of nails and spikes are used for each 1000 ft. Two men should cut and set from 600 to 800 ft. of 2" × 4" or 2" × 6" studding per day.

NOTE.—In all estimates for labor, handling lumber and erecting scaffolding are included.

Unless otherwise specified, the word "feet" used in connection with quantities of lumber means square feet or board measure.

As the corner posts are included with the studs, if the estimates are made as described above, do not estimate them again, but instead order them the full height of the corner.

Calculate the number of floor joists, common rafters, and tie beams needed, and add one for the starter. To find the number of jack rafters, those upon one side of each corner should be counted, and their length estimated as a full length common rafter, which will practically equal the actual measurement.

For setting rafters and floor joists, about 30 lb. of

spikes and nails per 1000 ft. will generally be used. Two men will cut and place about 500 ft. of rafters in a day, and, if the building is not too irregular, 1000 ft. to 1300 ft. of floor joists.

If sheathing is to be laid horizontally, estimate the actual area, making no allowance for openings or waste. If it is laid diagonally, allow 10 per cent for waste besides the openings. In estimating the roofing boards or sheeting, allow 25 per cent for waste if the sheeting is laid with close joints, but if there is a space of 2 inches between the boards, and they are not more than 6" or 7" wide, an estimate of a fourth less than the actual area will be safe. The above two items will require about 25 lb. of nails per 1000 ft.

For a day's work, two men should lay 1000 ft. of sheathing if laid horizontally, or 800 ft. if laid diagonally; if matched, the amount will be 20 per cent to 25 per cent less. Two men should lay from 500 ft. to 1000 ft. of roof sheeting per day, varying according to the number of hips and valleys in the roof. It generally costs about \$8 per M to handle and put sheeting in place.

A man should cut and nail six to eight sets of bridging per hour.

No prices for bolts, anchors, plates, and other iron work can be given which will be of any value, as they are governed by the state of the market, so the builder should always have figures submitted, if any considerable amount is to be used.

Circular towers, bay windows, etc., are usually estimated at twice the cost of straight work. Under floors may be laid at the rate of from 10 to 12 squares per day.

Many builders lump the above quantities, and estimate

the cost of the labor in framing to equal half of the cost of the material. Others estimate the framing at \$10 per M, which is in most places a fair price.

65. Roofing. — A carpenter will lay from 1500 to 2000 shingles per day, and use from $7\frac{1}{2}$ to 10 lb. of 4d nails, but there are professional shinglers who can lay as many as 5000. An all-round carpenter will rarely average more than the above, and not that if the roof is very badly cut up. Generally it will cost about \$1.50 per M to lay shingles.

A box of tin for roofing will cover about 180 sq. ft. and require about 10 lb. of solder, 2 lb. of tinned roofing-nails, and about 15 hours' work to prepare the tin for the roof and to put it on. To this is to be added the cost of painting the under side of the tin before laying. In dry climates this is not often done. Painting the roof after it is laid is often a part of the painter's contract, though the first painting is considered part of the original cost of the roof.

Though the price of a tin roof usually is estimated at from \$8 to \$10 per square, the above data will allow the roof to be estimated according to local conditions.

A slate roof should be estimated by one who makes that work a business, but generally \$9 per square is a safe estimate, though the price varies between \$7 and \$12, according to the nature of the roof, the quality of the material, and the work required.

66. Joinery. — Under the head of joinery we shall treat the building after the carpenter has finished the framing, covering, and roofing, and discuss the topics of inside and outside finishing.

The items to be considered under the above head are as follows: —

Outside Finish

Base or water table.
 Corner boards.
 Cornice.
 Moldings.
 Siding.

Windows

Blinds.
 Frames.
 Glazing.
 Sash.

Doors

Doors.
 Frames.

Inside Finish

Architraves.
 Baseboard.
 Corner blocks.
 Flooring.
 Moldings.
 Plinths.
 Wainscoting.

Stairs

Balusters.
 Handrail.
 Newel posts.
 Rail bolts.
 Risers.
 Section posts.
 Skirting boards.
 Stringers or carriages.
 Treads.

Veranda

Balusters.
 Brackets.
 Capitals.
 Floor.
 Posts.
 Rail.

Miscellaneous

Grounds.
 Labor.
 Sheathing paper.
 Shelving.
 Shingles.

Window frames may be bought at prices which range between \$1 and as high as a specially designed and very elaborate frame may cost ; but a good frame, and such as is in common use, may be bought for from \$1.25 to \$1.75. Usually they arrive from the factory in shooks, or knocked down, so about $1\frac{1}{2}$ hours should be allowed for nailing up and setting each frame. In this, as in all work, add 5 per cent for each story in height for the cost of handling.

Doorframes cost the price of the stock which is usually bought all rabbeted; smoothing, nailing up, squaring, and setting an inside frame will usually require about $1\frac{1}{2}$ or 2 hours. A common outside frame, with its casing and threshold, will require about another hour.

Two good men should build their scaffolds and put in place from 160 to 180 ft. of cornice per day, unless there are a great many angles. This includes all the work from the siding to the upper edge of the gutter bed, or to the place where the roof proper begins, and will require about $4\frac{1}{2}$ lb. of nails for 100 ft.

Another method is to figure the width of the cornice in inches, and allow 1^c per inch in width to each foot in length in the length of the cornice; this will pay for all the material and labor of scaffolding.

In estimating corner boards and siding, the actual wall area is taken, and no allowance made for single openings, thus balancing the waste upon ordinary houses. To this should be added a fourth for the lap of 6'' siding. If some form of matched siding is used, a third of the area should be added, as 4'' siding will usually cover about $3\frac{1}{4}$ '' upon the wall, and narrow boards cut to waste more than wide ones. When the above method is used, there is no need of estimating the corner boards separately.

Two men should lay from 500 ft. to 700 ft. of siding, and use from 9 to 12 lb. of nails for a day's work.

Many contractors consider the cost of the labor of putting on outside finish as half of the cost of the material.

In estimating the material for flooring, add a fourth to the area for waste, not measuring stairs or other large openings. A room which is badly cut up by angles and

curves generally should be estimated to its extreme dimensions, to recompense for the extra labor of cutting.

If a square-edged floor is to be laid, a fifth is sufficient allowance for waste.

From 2 to 3 lb. of nails per square are necessary to lay matched flooring.

A man should lay from 3 to 4 squares per day of matched softwood flooring of good material, blind nailed; if less than 4" wide, he should lay from 2 to 3 squares per day.

Of hardwood flooring, a man will lay from a fourth to a third less than the above quantities, and of a square-edged floor a man should lay from 6 to 8 squares per day.

Ceiling wainscoting, finished with cap and scotia, can be nailed and finished at the rate of from 2 to $2\frac{1}{2}$ squares per day upon ordinary straight work, using 2 lb. of 6d finish nails per square.

Panel work or dado may be set up (not made) and finished at the rate of about $1\frac{1}{2}$ squares per day, with an average amount of detail in the base and cap. No price can be given for the cost of paneled dado, as it can be made for almost any amount; the builder should obtain a figure from a factory before submitting an estimate.

It is usually safe to estimate a third more for the labor upon hardwood than upon softwood work.

A man should smooth, fit, and nail in place from 50 to 60 linear feet of three-member base per day, including mitering the outside and coping the inside angles, unless there are a great many.

It is a fair day's work to fit, hang, and mortise lock five inside doors; if rim locks are used instead, seven doors require about the same amount of work to fit the lock so that the door does not rattle.

It is about one hour's work to case around a door or window frame with a corner block and plinth casing; a mitered finish will require usually about one half more time. It is a common method to lump the mill work of a house and estimate the cost of the labor of putting it in place to equal one third or one half of its cost, according to the work required.

To fit, hang, trim, and put the stops on five windows, will constitute a fair day's work. Many contractors figure the windows as finished complete, with blinds and painting, at \$10 per opening, which is safe for an ordinary house.

Doors may be estimated by figuring the cost of the material and adding $1\frac{1}{4}$ day's work for an inside door, and $1\frac{3}{4}$ day's work for an outside door, if the latter is set with a hardwood sill and a thorough job is to be done. An inside door will require a good day's work to complete it, from making the frame to cutting down the threshold.

In the pantry, and other places which require shelving, a man should put in place from 60 to 75 ft. per day.

The cost of stairs varies greatly with the design, but it is usually safe to estimate that it will require one day's work to two and a half risers in height, if they are not too intricate in their design.

Box stairs usually require about one day's work to six risers in height.

A man should lay in place between 300 and 400 linear feet of grounds per day, straightening them up in good shape.

Mantels and other special woodwork are furnished some-

times by the carpenter. The owner often selects them himself, but the contractor pays for them, the owner paying any extra cost above the price allowed in the contract, which may be necessary to secure a special design to which he takes a fancy.

67. Plastering. — The material and labor required for 100 sq. yd. of three-coat work are as follows: —

1500 laths.	18 hours' work for two plasterers and one helper.
10 lb. 3d fine nails.	36 bu. sand.
7 hours' work in making up mortar.	8 lb. or 1 bu. of hair.
1 day's labor lathing.	$\frac{1}{2}$ bu. plaster of Paris.
12 bu. lime.	

The custom of measuring for plastering varies, though the square yard is generally the unit. It is quite usual not to deduct single openings, and to measure only half of the double openings, treating the rest as solid wall. All strips less than 12'' should be measured as 12''; for small closets add a half to the actual measurements. A man will lay about 1500 laths a day. Two plasterers and one helper will, upon ordinary work, build their stagings and do about 50 yd. per day of three-coat work. Roughly speaking, the plastering costs about 10 per cent of the entire cost of the house. Lathing and plastering vary in price according to locality from 20¢ to 25¢ for two-coat work, to 25¢ to 30¢ per square yard for three-coat work. In certain sections of the country, two-coat work is used exclusively.

68. Hardware. — The following is a list of the articles of hardware needed upon a house: —

<i>Doors</i>	<i>Windows</i>
Bolts.	Blind trimmings.
Butts.	Sash cord.
Cupboard catches.	Sash fasts.
Hinges.	Sash lifts.
Mortise locks.	Sash weights.
Rim locks.	Special glass.
Stops.	Transom lifts.
	Transom locks.

Miscellaneous

Anchors.	Ornamental iron work.
Bolts.	Plates.
Drawer pulls.	Rail bolts.
Hooks and eyes.	Rods.
Nails, spikes, screws, etc.	Washers.

Upon ordinary work, the hardware will cost from 3 per cent to 5 per cent of the cost of the house, and 20 per cent of their cost will pay for putting on the trimmings.

69. Painting. — The following figures are about the average for the whole country, but the builder should be sure that they are safe for his locality, before he uses them as the basis of an estimate.

One gallon of paint will cover 200 sq. ft. of new wood, two coats, and 300 sq. ft. of metal roof, one coat.

It is usually safe to estimate that the labor of putting on paint will cost about $1\frac{1}{2}$ times the cost of the paint upon plain work; and upon difficult work, or work in two or more colors, twice the cost of the paint should be allowed for the labor. The labor for varnished work should be estimated as costing about $1\frac{1}{2}$ times the material.

Interior work will cost about 20¢ per sq. yd. for two-coat, and 25¢ for three-coat work. A plastered wall sized and covered with three coats of paint will cost about 20¢ per sq. yd.; stippled, about 30¢. Hardwood finishing will cost about 40¢ per sq. yd. for filling and two coats of varnish.

Painting generally will cost from 12 to 16 per cent of the cost of the house, but upon rough buildings and cheap work it is sometimes reduced to 6 or 8 per cent.

It costs 25¢ per double roll to hang common wall paper.

In measuring for areas of painting, make no allowance for openings, as the difference in the work, the under edges of the siding, curves of moldings, etc., will make the measurement just.

A painter can legally claim the privilege of measuring the height of a building by a tape measure, carefully fitting it into all the angles and curves of the siding, water-table, and moldings of the cornice, as all of these surfaces have to be covered with paint.

70. Heating and plumbing. — We will not go into the detail of heating and plumbing, as in every case there are so many different methods of accomplishing results that any data which could be furnished here would be of little value. So we will simply state that a hot-air system will cost from 5 per cent to 8 per cent of the cost of the house, steam heat from 6 per cent to 10 per cent, hot water from 8 per cent to 12 per cent, plumbing about the same, and if the house is to be piped for gas, from 2 per cent to 4 per cent will pay for the piping without the fixtures.

71. Summarizing the estimates. — After the quantities and dimensions of the different sizes, kinds, and grades of material have been calculated and their totals ascertained,

the information should be filed away. This unpriced list should be sufficiently accurate, in regard to the quantities and dimensions, to be used in ordering much of the bill stuff, and of the cheaper lumber and other materials which can be ordered by quantity, and be cut afterward. If the figuring has been too close, there may not be enough of the rough material for use as temporary bracing, scaffolding, etc.

The totals of the above quantities and sizes should be arranged by the methods indicated in the following outline, which mentions only enough of the items to suggest the method to be followed; the prices should be carried out, and added to ascertain the total cost of the material.

To this should be added from 5 per cent to 25 per cent each for incidentals and profit. This should be enough, in the judgment of the contractor, to provide a safe margin for all reasonable contingencies, and at the same time to allow him a fair chance of being awarded the contract.

TIMBER

4654 ft. dimension lumber for bill stuff, at \$20 per M	\$93.08
3000 ft. hemlock sheathing 16' and 18' long, at \$18 per M	} 81.00
1500 ft. hemlock sheathing for roof, at \$18 per M	
12,000 best cedar shingles at \$4 per M	48.00
600 ft. maple flooring, 4" matched, at \$40 per M	24.00
Total	<hr/>

MILL WORK

4 cellar frames at \$1.25	\$5.00
3 window frames 14" × 30", 4 lt. at \$1.75	5.25
11 sets of door jambs at 60¢	6.60
3 porch columns 8" × 8', turned, at \$3.50	10.50
Total	<hr/>

CARPENTER WORK

4654 ft. framing lumber at \$10 per M	\$46.54
4500 ft. sheathing at \$8 per M	36.00
12,000 shingles at \$1.50 per M	18.00
90 ft. of cornice at 15¢ per linear foot	13.50
One third cost of mill work for finishing	42.90
Stairs	18.00
Total	<hr/>

SUMMARY

Excavating and masonry	230.00
Dimension lumber	315.64
Mill work	128.60
Carpenter work	235.67
Hardware	31.90
Tin work	13.60
Plastering. 450 yards at 25¢	112.50
Plumbing	190.00
Painting	49.60
Total	<hr/> \$1307.51
Incidentals, use of equipment, etc., 8 per cent	104.60
Profit, 10 per cent	130.75
Grand total	<hr/> \$1542.86

72. Stock bill. — After the estimating has been finished, the student should make out the stock list, which should include in detail the quantities and sizes of every item to be used in the construction of the building, which is not included with sufficient accuracy in the approximation list.

In making this bill, the student should follow closely the instructions and lists of items as included in Topics 61 to 69. Each item should be carefully considered and checked to insure that none are missed or figured twice. Each item to be listed should be specified and estimated generally to the nearest stock dimensions, when framing

material and other supplies, which will have to be cut to exact dimensions upon the work, are being considered.

The following bill should be ample to suggest the method generally followed in making out the stock list for a building; it includes only items which the carpenter uses, since the masonwork, painting, etc., are usually sublet, the subcontractors making out their own stock lists. The list is only suggestive, and is not to be followed in selecting items, as it is intentionally incomplete, it being assumed that the student will work in accord with the suggestions previously made.

JOHN DOE & SONS
CONTRACTORS AND BUILDERS
CHICAGO, ILL.

DATE, *Jan. 1, 1912.*

BILL OF MATERIAL FOR

6 Room Cottage

FOR *John Smith, Esq.,*
2240 Main Street,
Chicago, Ill.

MR. *Richard Roe,*

Dealer in Builders' Supplies.

Dear Sir:

Please deliver at the above address the following supplies, and charge them to our account.

Very truly yours,

John Doe & Sons.

FRAMING

- 6 2'' × 6'' × 12' sills.
- 14 2'' × 6'' × 14' sills.
- 9 2'' × 8'' × 16' girders.
- 24 2'' × 8'' × 12' floor joists.
- 68 2'' × 4'' × 14' studs, plates, etc.

FINISH

- 9 window frames, 14'' × 30'' × 1 $\frac{3}{8}$ '' 4 lt.
- 17 window frames, 14'' × 28'' × 1 $\frac{3}{8}$ '' 4 lt.
- 9 door frames, 2' 8'' × 6' 8'' × 1 $\frac{3}{4}$ '' . 1 $\frac{3}{8}$ '' × $\frac{1}{2}$ '' rabbet.
- 90 ft. 4'' crown molding.
- 90 ft. 3 $\frac{1}{2}$ '' × $\frac{7}{8}$ '' fascia.
- 2000 ft. 4 $\frac{1}{2}$ '' matched siding.
- 9 #2 doors, 2' 8'' × 6' 8'' × 1 $\frac{3}{8}$ ''.

HARDWARE

- 100 lb. 8d com. nails.
- 100 lb. 20d spikes.
- 50 lb. 8d finish nails.
- 6 mortise locks.
- 36 6-lb. sash weights.

Never use ditto marks ("") to repeat figures, as they very often cause errors. Stock bills should always be made out in duplicate, by means of carbon paper, one copy to go to the dealer, and one to be retained by the builder, as one may be lost, and mistakes may be checked.

73. The contractor. — Whenever unsuccessful, the young contractor should endeavor to discover, if possible, in what way his successful competitor was able to do the work more cheaply than he could. Did the successful competitor's figures differ in regard to material or labor? Was the material used the same that he would have furnished? If the builder who is doing the work is

a successful man, a young contractor may learn much in regard to the faults of his own estimate.

A feeling of antagonism exists among a certain class of builders toward an architect, and many do not hesitate to cause him all the annoyance possible. This is a very shortsighted policy, as an architect's advice to his client is usually of great weight, and the contract is not always awarded to the lowest bidder. If an architect has had unsatisfactory dealings with a builder, he will, like most people, avoid him as much as possible in the future.

Architects, as a rule, are suspicious of builders, and naturally so, as the antagonistic builder is found everywhere, and until confidence is established, the architect is apt to be very searching and particular in his examinations and requirements. The more friends among the architects a builder can gain by his honesty and ability, and the more he can inspire their confidence, the better work, the more work, and the better prices he can command.

The young contractor should be very careful in regard to the legal aspects of a contract, as there are many ways in which an unscrupulous man might take advantage of technicalities, and the young builder should make a study of forms of contracts and the conditions which govern them, and which they govern.

Blank contracts covering all of the conditions usually observed in a building contract may be secured from a stationer who deals in legal forms.

Every city of importance has building regulations suited to its own local conditions, and these should be carefully followed, or much expense and annoyance may be caused.

A building permit is usually required in most cities, and it is generally the builder's place to secure it.

A treatment of the legal aspects of the work of a contractor is not within the province of this book, therefore mention only is made of its importance.

SUGGESTIVE EXERCISES

58. What should the contractor always insist on having when estimating a house?

59. What should the contractor know of the location of the house and the subsoil?

60. Describe the approximation method of estimating. Describe a safe method of estimating. Are the prices of labor and material the same in all localities? What should the contractor endeavor to attain in estimating the cost of a building? What is necessary in order to estimate methodically? How are the different items treated? How is the total of each division of items treated to find the cost? What is the range of percentages added, and for what?

61. What is included in the estimate of the excavation of a building? What conditions govern the distance to which the excavated earth is to be carried? What is a day's work for two men excavating with a wheelbarrow? With a horse, cart, and driver? What is the proportion of the cost of filling and grading to the cost of the excavation?

62. What is the safest way for a carpenter to find the cost of the masonwork of a building? How should these estimates be made a part of the bid for an entire job? Name at least twelve items which should be considered in estimating masonry. What is generally the unit of measurement for stonework? Recite the table of quantities. How is a wall usually measured to estimate the quantity of stone in it? What is the usual rule in regard to the measurement of small openings? Of large openings? What is the proportion of stone in a wall to rough stone? What is a day's work for a man and a helper in laying rubble? Ashlar? How much lime and sand should be used for each? What is a day's work for a stonecutter upon granite or bluestone?

63. How is a brick wall usually measured? What is the method of measuring a brick wall for the slow burning type of building? How many bricks are there in a square foot of wall surface? In a two-brick wall? In a three-brick wall? How many bricks are there in a cubic yard of solid brickwork? What is the allowance for breakage and

waste? How much lime is used to lay 1000 common bricks? 1000 face bricks? What is a fair day's work for a bricklayer upon ordinary work? Upon face brick? Make a stock bill of the masonry work of a small house with the estimate, working from a plan.

64. Mention twenty-five items to be considered in estimating the frame of a house. What is the common method of finding the number of studs needed? Is this accurate? Why is it most used? Explain a more exact method, and compare the two. How many nails should be used in setting 1000' of studding? What is a fair day's work for two men in studding a house? How are the corner posts usually estimated? How are they ordered? How is the number of floor joists, rafters, etc., found? How is the number of jack rafters found? How many nails will be used in setting 1000' of the above? What is a fair day's work in setting the above?

How can sheathing be estimated if laid horizontally? Diagonally? How can the sheeting for the roof be estimated? If laid with 2" open joints? How many nails are used for these items per 1000'? What is a day's work upon each of the above? How many sets of bridging should a man make in an hour? Why cannot prices for iron work be given? Make a stock bill for the framing material for a small house, with the estimate, using a plan.

65. What is a fair day's work in shingling? Estimate the cost of a square of shingles laid. Estimate the cost of a square of tin roofing laid. What is an average price for slate roofing?

66. Name thirty items which should be considered in estimating joiner work. What is the approximate price of common window frames? How much does it cost to nail them together?

How much does it cost to set an ordinary frame? How does the cost of handling material differ with the stories of the house? How long will it take to smooth and set up a doorframe? How much cornice should two men put up in a day? Describe two methods of estimating cornice. How shall corner boards and siding be estimated? How much siding should two men lay in a day? How do some men estimate the cost of the labor upon framing and outside finish? How is flooring estimated? How many nails are used to a square of flooring? What is a fair day's work in laying pine matched flooring? Maple? What is the general proportion of cost between hardwood and softwood finish? How much square-edged flooring should a man lay in a day?

How much ceiling wainscoting should be completed in a day? What is a fair day's work in hanging and finishing doors? How long will it take to case around a door upon both sides? How many windows should a man finish in a day? How much three-member base should be put in place in a day? Describe a method of estimating a window in a lump sum. How long will it take to finish a door complete? How much shelving should be put in place in a day? What is a day's work in putting in a flight of stairs? What will the labor cost upon a flight of stairs of 16 treads? What will the labor upon a 12-rise box staircase cost? How many grounds should a man put in place in a day? Make the stock bill of finish for a small house, and estimate, working from a plan.

67. What material is necessary for 100 sq. yd. of plaster? Describe the rules for measuring plastering. How many laths should a man lay in a day? What is a day's work for two plasterers and a helper? What is the proportion of the cost of the plastering to that of the entire house? Make a stock bill for a small house with estimate, working from a plan.

68. Name ten items to be considered in estimating the hardware for a house. What per cent of the cost of a house is the cost of the hardware? Make a hardware bill for a small house with the estimate.

69. How much new wood will one gallon of paint cover? How much metal roof will it cover? What is the proportion between the cost of labor and the cost of paint? Between the cost of labor and the cost of varnish? How should the exterior of a house be measured? What is the approximate cost of interior work? What is the proportion between the cost of the painting and the cost of the whole house? What does it cost to lay paper?

70. What would be an approximate percentage of the cost of a hot-air furnace for the small house above estimated? Steam? Hot water? Plumbing? Gas piping? What should be considered in adding the profit?

71. Make a summary of all the estimates.

72. Make the stock bill of a small house with estimate.

73. What is a good plan for a young contractor to follow in estimating? Describe the relations between the architect and builder, as they sometimes exist. What is the reason for an architect's distrust of a certain class of builders? Why are such builders unwise?

CHAPTER VIII

ARITHMETIC

1. If it is estimated that 100 ft. of lumber are necessary to do a certain piece of work, and but 78 ft. are used, what per cent is saved?

2. If the hardware upon a \$1000 job cost \$18, what per cent of the whole was the cost of the hardware?

3. If the labor and material cost \$14.50, what will be the price if a profit of 8 per cent is charged?

4. What is the ratio of profit if a tool chest costs \$6 and sells for \$9?

5. If 45 ft. of lumber cost \$90, what will 150 ft. cost?

6. What per cent of profit is there in a job for which \$46.75 was paid, if the material costs \$32 and the labor, \$10.50?

7. If 200 ft. of lumber cost \$5 how much will 37 ft. cost?

8. If 30 ft. of lumber are estimated for a job, and only 27 ft. are used, what per cent is saved?

9. Measure the material in some article of furniture and estimate the quantity and price.

10. A lumber pile contains 1918 sq. ft., 575 sq. ft. are sold, what per cent is left?

11. What is the ratio of loss if an article costs \$5 and sells for \$3?

12. Estimate the number of bricks in a given wall or section of wall.

13. If $\frac{1}{3}$ of a piece of property is worth \$153, what is $\frac{5}{8}$ of it worth?

14. If 10 men do a piece of work in 12 hours, how long should it take 13 men to do it provided they could all work to advantage?

15. 150 ft. is the estimate for the stock of a job, but through careless cutting 165 ft. are used. What is the per cent of loss?

16. If A 's pay is 12¢ per hour, and B receives 60 per cent as much, what is B 's pay?

17. If they are put upon a job together and B does 50 per cent of the work, what per cent should B 's pay be raised, and A 's reduced, to make them even?

18. If a mason and helper can lay 1000 bricks a day, how long will it take them to lay a wall 40' long \times 18' high, and 20" thick, of low grade brick? As the bricks are over size, estimate 21 bricks to a cubic foot instead of $22\frac{1}{2}$ as usual.

19. If 15 lb. of nails cost \$.45, what will 40 lb. cost?

20. If 2000 ft. of lumber cost \$70, how much will 3500 ft. cost?

21. If A does a certain piece of work in 19 hours at 8¢ per hour, how much will it cost if B receives 10¢ per hour and does it in $\frac{2}{3}$ of the time?

22. If 17 per cent of a piece of work costs \$22, what will the whole work cost when completed?

23. Measure and estimate the material in a given length of fencing.

24. If $16\frac{2}{3}$ per cent of a piece of work costs \$7, what will the rest cost at the same rate?

25. What is the per cent of labor upon a job which costs \$46.17, if the material costs \$27?

26. Measure and estimate the material in the treads and risers of a given flight of stairs.

27. If A does 6 hours' work for 60¢, and B does the same amount of work in 5 hours, how much per hour ought B to receive for his labor?

28. Two men lay a floor containing 22 squares. A lays 8 ft. to B 's 10 ft. How much does each lay?

29. A , B , and C contract to do a certain piece of work for \$27. A does $61\frac{1}{2}$ per cent of the work, B $27\frac{2}{3}$ per cent, C $11\frac{2}{3}$ per cent. What amount of money will each receive?

30. If $12\frac{1}{2}$ per cent of a piece of work costs \$5.25, what will the entire work cost?

31. If 2 students do 10 per cent of a piece of work in 3 hours, how many will be necessary to do the whole in 10 hours if all work to advantage?

32. If 6000 ft. of lumber cost \$180, how much may be bought for \$967?

33. If 6 men are 9 days doing a piece of work, how long will it take 4 men to do it?

34. Divide 90 ft. of lumber into two parts having the ratio of 4 to 5 to each other.

35. Divide 246 into four parts which will have the proportions of 4, 6, 9, 13.

36. Measure and estimate the material in a given floor.
37. If a certain piece of work costs \$20 the first time it is done, and the next time it costs \$18.75, what per cent is saved?
38. The average work of *A* costs $\frac{2}{3}$ less than the average work of *B*. What per cent of difference should there be in their pay?
39. Two contractors figure \$3150 and \$3064.50 upon a job. What per cent of the larger bid was the difference in their bids?
40. Measure and estimate the material in a given case of drawers.
41. If two men can lay 6 squares of floor a day, what area of floor could thirteen lay in the same time?
42. 96 hours' work was divided equally between *A*, *B*, *C*, *D*, at 12¢, 10¢, 8¢, 6¢ an hour respectively. How much did each receive?
43. A cellar wall 8' high, 20' \times 35', and 12" thick is to be laid of stone costing in the wall \$4.50 per cu. yd. What will the wall cost?
44. *A* is paid 10¢ per hour for work, and his work is no better than that of *B*, who receives 8¢ per hour. What per cent should *A*'s pay be reduced?
45. Measure and estimate the cost of material in a given piece of furniture, and make a stock list including every piece used.
46. A certain room is 20' \times 30', and another room is to be made which is to be 20 per cent larger each way; what will be the area of the larger room?
47. At the rate of 12¢ for each $1\frac{1}{2}$ hours' work, how many hours' work will \$4.30 pay for?
48. If a floor is 20' wide, and $1\frac{1}{3}$ times as long, what is its area?
49. If 60 per cent of a job costs \$10, what will the whole job cost?
50. If 70 per cent of a job is material, what is the cost of a job, the labor of which costs \$22?
51. If a piece of work costs 7 per cent less than the contractor's estimate, which was \$1900, how much was his additional profit?
52. *A* generally requires $10\frac{1}{2}$ hours to do a piece of work which *B* can do in 9 hours. With *A*'s work as a basis, what should be the per cent of difference in their pay?
53. A shingle roof contains 88 squares, and must be done in two days; how many men laying 2 squares per day each will have to be hired?
54. What per cent of the cost of a job is the labor, if the material costs 61 per cent, and 10 per cent is allowed for profit?

55. In a heavy building, of mill construction, the bays are 8' to centers, timbers $12'' \times 14'' \times 20'$ long, and pieces of $6'' \times 8''$ are built into the walls to receive the ends of the flooring. The floor is to be $38' \times 80'$, $4\frac{1}{2}''$ thick, with floor openings aggregating 245 sq. ft. in area. Estimate the quantity of lumber necessary to construct the above floor, making no allowance for waste.

NOTE. — In the form of construction known as mill construction, the posts are placed from 7' to 9' apart, and support the floor timbers, which in turn support the heavy floor. The distances between the posts are called bays.

56. Make a stock list of the treads, risers, balusters, rails, and posts of a given flight of stairs.

57. Measure, make a stock list, and estimate the cost of the material of a given door.

58. A lumber dealer sells 100 ft. or 6 per cent of a lumber pile to one customer, 8 per cent to another, and the balance to a third at \$22 per M. What does he receive from the last customer?

59. *A* and *B* start upon two jobs just alike. *A* receives 10¢ per hour and *B*, 80 per cent as much as *A*; if *A* does his work in 9 hours, how long ought *B* to spend upon his?

60. If *A* and *B* do their work in the same time, what per cent of *A*'s pay should be withheld to make the cost of the two jobs the same?

61. If 12 men can build 180 ft. of fence in two days, how long will it take 18 men to build 500 ft.?

62. If a pile of lumber is worth \$168 at 4¢ per ft., and if a part worth \$23.52 is lost by fire, what per cent of the whole is left?

63. If it cost \$5 per square to lay a floor complete, how much will it cost to lay a floor 49' long, 30' wide at one end and $\frac{3}{5}$ as wide at the other?

64. A room is $24' \times 36'$, of which 13 per cent is to be occupied by a closet; what will be the remaining area?

65. If 26 per cent of the labor, the total cost of which was \$40, is furnished by *A*, and the rest by five others, what should each receive?

66. At \$6.50 per M, how much will the brick in a given chimney cost?

67. A workman estimates his time at 25¢ per hour and bids \$250 upon a contract. He receives the contract, which he fulfills in 883

hours. What per cent of his estimate has he made or lost by the transaction?

68. If a job costs \$6, of which \$2.25 is for material, what is the per cent of the cost of the material to the cost of the whole?

69. What are the total contents of two planks, if one contains 19 sq. ft., and the other 86 per cent of it?

70. If 60 ft. of lumber are cut for a certain piece of work, and but 42 ft. are used, what is the per cent of waste?

71. *A* and *B* could each accomplish about the same amount of work, but *A* was paid 30¢ and *B* 25¢, per hour. They were sent to do a piece of work together, which required 20 hours of each man. *A* cuts the material which he uses with practically no waste, while *B*, through carelessness, wastes $21\frac{1}{4}$ sq. ft. costing \$60 per M. Which is the less expensive man and by how much?

72. 1000 ft. of lumber weighing 3000 lb. was in the dryhouse 3 days, at the end of which time it had decreased 8 oz. per foot. What per cent of the original weight of the lumber had evaporated?

73. At the end of one week the lumber had thoroughly dried and its weight had decreased 40 per cent. What was its final weight?

74. If 1 cu. ft. of water weighs 62.42 lb., what would be the capacity of a tank to hold the water evaporated from the above lumber?

75. If a man pays \$5 for tools, and earns \$13.50 by his labor, what per cent has he made upon the money invested?

76. A building is 65 ft. span in the clear. The lower chord of the truss is $10' \times 14'$. Allowing the chord to rest 15 in. upon each side, how many sq. ft. are there in the timber?

77. Measure and estimate the cost of the floor joists which support a given floor.

78. Counting four courses to the foot, how many bricks will it take to build a three-flue chimney 42' high, flues to be one brick each way?

79. A cistern has 60 bricks to a course and four courses to a foot. What is the height to the arch if 2880 bricks are used?

80. If it takes 21 bricks to lay a cubic foot, how many bricks are there in a wall $60' \times 9' \times 16''$ thick?

81. A young man spends \$200 for his course in a trade school, and earns 75 per cent of it working for the school. How much does he have to obtain elsewhere?

82. After graduation the above young man earns \$50 per month for one year as a carpenter, and saves 50 per cent of it. What per cent of his entire earnings for the three years was left after his school debt had been paid out of his savings?

83. If the area of a certain wall is 88 sq. ft., and $33\frac{1}{3}$ per cent of it is glass, what is the area of the glass?

84. If a floor is 19' wide, and 40 per cent as wide as it is long, what is its length?

85. If 9 per cent of the above floor is cut out for a stairway, what is the area of the rest of the floor?

86. Estimate the cost of the hardware upon three given doors.

87. If *B* does a certain piece of work in 27 hours, and *A* does the same work in 11 per cent less time, how long does it take *A* to do it?

88. What per cent of the cost of a house is the painting, if the total cost of the house is \$1500 and the painting \$55?

89. What is the percentage of gain if lumber, bought for \$16 per M, is handled and worked at a cost of \$10 per M, and sold for \$29.02 per M?

90. Three boards measure 50 ft. One is $20\frac{1}{2}$ per cent of the whole, another is 35 per cent. What is the percentage of the other?

91. A student earns \$35 per term, of which he spends \$25. What per cent does he save?

92. A student borrows \$25, giving a note for 1 year at 6 per cent interest, payable at maturity. What will be the value of the note when it falls due?

93. A barn costs \$300, the stock inside \$500. If the barn burns and is a total loss, and 82 per cent of the stock is saved, what is the total loss?

94. If a circular saw does the work of 65 men, what per cent is gained if it takes one man to run it?

95. If the 65 men are paid \$1 per day each, and the cost for power, maintenance, and one man's time is \$6 per day, what is the actual per cent of profit from a circular saw?

96. What per cent of the cost of *A*'s work is the difference in the cost of two equal jobs, if *A* does one for \$6.40, and *B* the other for \$6.85?

97. If $12\frac{1}{2}$ per cent of the area of a room is occupied by a closet which covers $17\frac{1}{2}$ sq. ft. of space, what is the area of the room?

98. If the above room is $\frac{5}{7}$ as long as it is wide, what is its size?

99. What is the area of a board, if another, 85 per cent as large, contains 17 sq. ft.?

100. A house costing \$900 is built upon a lot of land which cost \$150. The property is insured for $\frac{2}{3}$ of the cost of the house, which burns, and is a total loss. What is the actual loss to the owner, after the insurance has been paid?

101. Measure, make the stock list, and estimate the cost of the stock in a given case of drawers.

102. A saw cuts 6000 feet of lumber in a day, which is sold for \$12.50 per M. If it costs 70 per cent of the selling price for stumps, hauling, sawing, and handling, what is the profit upon the day's work?

103. If 50 men are paid \$2 per day each, and it costs \$220 for the material they use, what must be received for the work to give a profit of 8 per cent?

104. Two jobs cost respectively \$12.80 and \$13.90. The difference is what per cent of the more expensive job?

105. If $12\frac{1}{2}$ per cent of the area of a room is occupied by a closet which covers 18 sq. ft. of floor space, what is the area of the room?

106. What is the size of the above room if it is 14' upon one side?

107. If the above room is $8' 11\frac{3}{4}''$ high, how many cubic feet of air will it contain?

108. Estimating 575 bricks to a cubic yard, how many bricks are there in a pile $3' \times 5' 4'' \times 15' 4\frac{1}{2}''$?

109. If a granite capstone 10'' thick will safely support a load of 700 lb. per sq. in., what should be the area to carry a load of 152,000 lb.? Give the answer in sq. ft.

110. If a limestone foundation is to support 395,000 lb., and the stone will safely carry 250 lb. per sq. in., what will be the required area?

111. If compact gravel and sand will carry a load of 7 tons per sq. ft., how large an area will have to be covered to carry a load of 360,600 lb.?

112. If clay will safely support a load of 2 tons per sq. ft., how heavy a load will a footing $7' \times 7'$ support?

113. If a Portland cement foundation made of 1 part of cement, 2 of sand, and 5 of broken stone will support 150 lb. per sq. ft., what will be the necessary area to carry safely 98,000 lb.?

114. If painting costs 10¢ per sq. yd., how much will it cost to paint 16 squares?

115. A house is built at a cost of \$860 and lies idle for one year. It is then sold for \$900.51, which includes cost of transfer. With interest at 6 per cent, what per cent is lost?

116. A workman made a tool chest, the material for which cost \$1.75; he sold it for \$8. What per cent of the selling price represented his labor?

117. A table which cost \$1.50 to make, sold for \$1.35. What was the per cent of loss?

118. Measure, make the stock list of a given fence, and estimate the cost of the material.

119. Measure and make the stock list of a given veranda floor and its supports.

120. A panel door has 2125 sq. in. of surface, 1241 of which are occupied by panels. What per cent of the entire surface do the panels occupy?

121. Select a small shed or outhouse, and make the stock list of all the material used in its construction.

122. What pay should be given to *A*, who does $\frac{7}{8}$ as much work as *B*, who earns 8¢ per hour?

123. If 571.32 ft. is 23 per cent of the amount of the stock required to do a certain job, how much is needed for the whole?

124. To decide which can produce work with less expense, *A* and *B*, receiving 28¢ and 30¢ per hour respectively, agree upon a contest, each to make three packing boxes of the same dimensions. *A* does his work in $2\frac{3}{8}$ hours, while *B* requires 3 hours to finish his work. Which is the more profitable man, and by how much?

125. Estimate the length of shelving necessary to accommodate a given quantity of books.

126. If 20 per cent of the cost of a job is labor, 7 per cent nails, 15 per cent painting, 10 per cent profit, what is the percentage of the value of the other material?

127. If 27 pieces of lumber are required for a piece of work, aggregating 165 ft. of material, what per cent of the whole is one piece?

128. What per cent of a pile of lumber containing 1972 ft. is left, if 1368 ft. are sold?

129. If 276.027 ft. are 19 per cent of a pile of lumber, how much is there in the whole pile?

130. If 5 ft. of lumber is wasted in sawing 600 ft., what per cent is wasted?

131. Make a stock list for the finish of a given room.

132. A bought a lot of land for \$100, giving his note at 7 per cent. He built a small barn upon it, the material for which cost \$175. At the end of one year he sold the property for \$350. What per cent of this amount was his own?

133. If $\frac{1}{3}$ of the cost of one piece of work is \$56, or the completed cost of another, what is the per cent of difference between the two?

134. What is the per cent of profit of a piece of work which cost \$28.50, and was sold for \$36.70?

135. If 7 men together do a piece of work, 2 of whom receive $\frac{1}{3}$ of the amount paid, what per cent will each of the other 5 receive if all receive equal amounts?

136. A builder borrows \$1000 on a 4 months' note to help him complete a contract. When the note matures his payment is \$1037.50. What was the annual rate of interest?

137. Estimate the siding of a given house, making no allowance for openings, and allowing $\frac{1}{4}$ of area for waste.

138. A house cost \$1225. The owner lived in the house three months, during which time he made repairs costing \$173.90. He then sold the property for \$1600. Estimating interest at 6 per cent, and the rent of the house at \$15 per month, what was the profit upon his investment?

139. A student works all summer, and all of the time possible outside of school hours. He earns \$135 per year, out of which he pays three terms' bills at \$30 per term, sends \$20 home, and uses the rest for incidentals. What per cent of the whole is the latter item?

140. A certain job requires $\frac{1}{2}$ as much lumber as is used upon two other jobs, one of which uses 29 ft., or 36 per cent as much as is used for the two. What is the total amount used for the three jobs?

141. A lumber dealer buys lumber for \$20 per M, holds it at an expense of \$2 per M, and sells it for \$30.50 per M. What is the per cent of profit?

142. A student pays 82 per cent of his money or \$30 for one term's school expenses, and the rest for incidentals. How much did he have originally?

(Questions 143 to 155 inclusive are suggestions for drill.)

143. What is the first power of 4; 8; 12?
144. What is the second power of 3; 9; 20; 25?
145. What is the third power of 6; 8; 12; 18; 30?
146. Raise the following numbers to the powers indicated by the exponents: 3^1 ; 12^2 ; 8^3 ; 12^3 ; 18^4 ; 30^3 .
147. Square 6; 3; 5; 80.
148. Cube 3; 5; 9; 17.3978.
149. What are the two equal factors of 25; 156.25; 324; 600.25; 1600?
150. Of what number is 4 the second power? 9; 49; 81?
151. How many orders are there in the square roots of 100; 2809; 36,864?
152. How many orders are there in the square roots of 9; 49; 64; 81?
153. What is the square root of 4; 9; 16; 25; 49; 81; 100?
154. What is the square root of 625; 768; 5280; 12,967; 192,621?
155. What is the square root of 9.612; 22.94; 323.96; 4919.61?
156. What is the length of the diagonal of the floor of a closet 8' long and 6' wide?
157. The floor of a building is $24' \times 32'$; what is the length of its diagonal?
158. The diagonal of a room is 16', the height is 12'; what is the length from the corner at the floor to the corner at the ceiling, diagonally opposite?
159. A ladder is resting against the plate of a house, at a point 20' from the ground. The foot of the ladder is 4' 9" from the house. What is the length of the ladder?
160. What would be the height of the riser of a flight of stairs which has a total rise of 9' 3" from floor to floor?
161. If a building is 8' clear from floor to ceiling, the lath and plaster 1" thick, floor joists $2'' \times 8''$, and the flooring of the second story 1" thick, what will be the rise of the stairs?
162. A flight of stairs in a school building has 18 risers which extend $10' 1\frac{1}{2}''$ from floor to floor. What is the height of each riser?
163. If there are 15 risers and the treads are 10" wide, what will be the entire run of a straight flight of stairs?
164. If a step has a rise of $7\frac{1}{2}''$, and a run of $10\frac{1}{2}''$, what will be the full width of the tread?

165. A straight run of stairs has 14 risers, and the treads are $11\frac{3}{4}$ " wide. What will be the entire run of the stairs?

166. If a floor has an area of 700 sq. ft., and one side is 20', what is the length of the diagonal?

167. What would be the dimensions of a perfectly square room 1.72 sq. ft. larger than the above room?

168. If the length of an armory is 80' and its diagonal is 100', what is the width?

169. A building is 28' high, and throws a shadow 18' on level ground. How far is it from the end of the shadow to the top of the building?

170. The distance from the top of a pole to the end of its shadow on the ground is 75.05'. If the shadow extends 40' from the base, how high is the pole?

171. What are the dimensions of each step of a flight which rises 108" and has a run of 135"?

172. What would be the full width of the tread of the above steps?

173. What will be the total fall of a drain which is 450' long, and has a pitch of 3" to every 50'?

174. What will be the pitch per foot of the outside drain of a house 28' \times 40', if it is 8" lower at the S.W. corner than it is at the N.E.?

175. A drain is to be laid around the inside of a cellar 32' \times 50', one foot from the center of the drain to the inside of the wall. If it has a fall of 4" to 50', what will be its total fall?

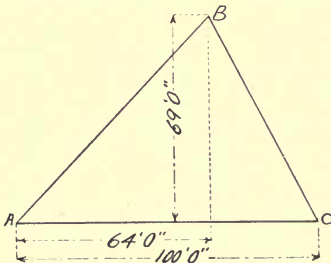

FIG. 78.

176. If the diameter of a circle is 23", what is its circumference?

177. What is its area?

178. The circumference of a circle is 45.86736 ft. What is its diameter?

179. What is the area of a circle 14'6" in diameter?

180. How many circles with an area of 2.1 sq. ft. will be contained in a circle with a circumference of 25.13 ft.?

181. What is the area of a lot of land of the dimensions shown in Fig. 78?

182. How many gallons of water may be contained in a cistern 10' in diameter, and 10' high? (See Table 29, page 216.)

183. How many gallons of water may be contained in a cistern 9' in diameter and 7' high?

184. What is the area of an irregular, four-sided floor the diagonals of which meet at right angles and are 70' and 39.889' respectively?
Suggestions for drill in the use of:

185. Signs of division.

- (a) $6 \div 3$; (b) $12 \div 6$; (c) $50 \div 2$; (d) $60 \div 3$; (e) $80 \div 4$;
 (f) $9 : 3$; (g) $8 : 2$; (h) $28 : 7$; (i) $110 : 11$; (j) $36 : 9$; (k) $50 : 25$;
 (l) $75 : 15$;
 (m) $49 / 7$; (n) $28 / 4$; (o) $96 / 24$; (p) $65 / 5$; (q) $80 / 16$;
 (r) $42 / 7$;
 (s) $\frac{24}{6}$; (t) $\frac{92}{2}$; (u) $\frac{22}{11}$; (v) $\frac{39}{13}$; (w) $\frac{165}{5}$.

186. Vinculum.

- (a) $\overline{5 + 6} \times 7$; (b) $\overline{9 - 6} \times 6$.

Parenthesis.

- (c) $(6 + 10) \times 9$; (d) $(5 - 3) \times (6 + 9)$;
 (e) $(5 \times 6) (7 - 5)$; (f) $(6 + 18) 12$.

Brackets.

- (g) $[9 + 12] \times 6$; (h) $[7 - 3] \times 12$; (i) $[6 + 4] \times [5 - 1]$;
 (j) $[5 + 3] \times 6$.

Brace.

- (k) $\{6 + 5\} \times 5$; (l) $\{5 + 3\} \times 2$; (m) $\{4 + 6\} \times 9$;
 (n) $\{4 - 3\} \times 21$.

187. Radical sign.

- (a) $\sqrt{3 + 6}$; (b) $\sqrt{32 \times 2}$; (c) $\sqrt{9 + 7}$; (d) $\sqrt{(3 \times 15) + 4}$;
 (e) $\sqrt{(7 + 5) \times 2 + 1}$; (f) $\sqrt[3]{(6 \times 4) + 3}$; (g) $\sqrt[3]{(4 \times 8) \times 2}$.

188. Use signs as follows:

- (a) $[(3 \times 4) + 6] 2$; (b) $[(12 \times 3 \div 4) \times 6]$;
 (c) $[(\overline{6 + 9 \times 3} - 5) \div 4] \times 12$;
 (d) $\frac{(6 \times 5 \times 3) \div 6}{5}$; (e) $\frac{\sqrt{12 \times 3} + (2 \times 21)}{16}$;

$$(f) \sqrt{\frac{\left(\frac{\sqrt{27 \times 3} + 149991}{3000}\right)}{\left[\frac{\sqrt{4 \times 5 + 5} + (20 \times 7 + 5)}{(2 \times 5) \times (10 + 5)}\right]}};$$

$$(g) \frac{\sqrt{[(9 \times 169 + 60) 87] 2 + (12 \times 73 \times 64 + 618)}}{9}}{(6 \times 9 \times 2 + 36)}.$$

18

Formulas.

189. What is the area of a rectangle 400' \times 296'? Use the following formula in the solution of this problem.

L = length. W = width. A = area.

Formula A. $A = L \times W$.

190. Find $\frac{1}{2}$ of the cubic contents of a room 15 ft. long, 12 ft. wide, and 9 ft. high, using the following formula:

L = length.

H = height.

W = width.

C = cubic contents.

Formula B. $C = L \times W \times H$.

191. How many square feet of boards will be required to cover the two gables of a half pitch house which is 20' wide? Make no allowance for waste.

Area of a triangle.

B = base.

H = height.

A = area.

Formula C. $A = \frac{B \times H}{2}$.

192. How many feet of boards will be required to cover the gables of a third pitch house which is 24' wide? Make no allowance for waste.

193. How many square feet are there in a room which is 30' upon one side, 35' upon the other, and 25' wide?

L = length of short side.

W = width.

B = length of long side.

A = area.

Formula D. $A = \frac{L + B}{2} W$.

194. What is the area of an octagonal room which is 5' upon each side, and 6' $\frac{1}{2}$ " from the center to the side?

L = length of one side. N = number of sides. A = area.
 W = perpendicular distance from the center to the side.

Formula E. $A = \frac{LNW}{2}$.

195. Find the area of an irregular polygon, by the method indicated in Fig. 79.

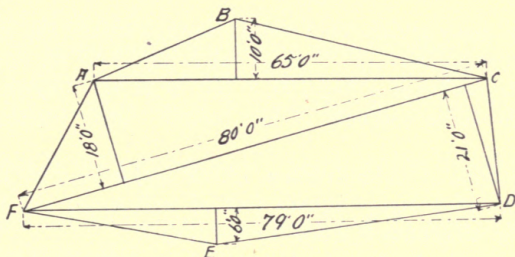

FIG. 79.

196. Find the circumference of a circle which is 9' in diameter.

π = pi, the ratio of the diameter to the circumference, = 3.1416.

C = circumference. R = radius. D = diameter.

Formula F. $C = 2 \pi R = D\pi$.

197. What is the diameter of a circle which is 39.27 ft. in circumference?

Formula G. $D = \frac{C}{\pi}$.

198. What is the area of a circle which is 7' in diameter?

Formula H. $A = D^2 .7854$.

Another method. Formula I. $A = \pi R^2$.

199. Find the diameter of a circle which is 314.16 sq. ft. in area.

Formula J. $D = \sqrt{\frac{A}{.7854}}$.

200. What is the area of a circular wall 12' in diameter outside, and 9' inside?

201. Find the length of an arc of 24° which has a radius of 6'.

L = length of arc.

R = radius.

N = number of degrees.

C = circumference.

Formula K. $L = \frac{RN}{57.3}$.

Another method. Formula L. $L = \frac{C}{360}N$.

202. What is the area of a circular auditorium which is 160' in diameter?

203. How many pupils could stand sideways around the wall, if each occupied approximately 12'' of space, allowing 30.46' for openings?

204. If the ceiling of a hall $150' \times 150'$ is 21.4377' above the floor, what are the cubic contents of the room? Omit fractions in the answer.

205. The walls of an auditorium, 120.58' square and 25' high, are to be plastered. How many square feet of wall space will have to be covered if no allowance is made for openings?

206. What is the brick area of a wall which is $39.20' \times 40'$ upon the outside, pierced with a circular hole which is 20' across?

The steel square is to be used as much as possible in the solution of the following problems.

207. If a building is $28' \times 40'$, and the batter boards are 5' from each corner, what is the distance between their corners?

208. What will be the length of the diagonals of the above batter boards?

209. If a building is $24' \times 32'$, what is the length of each diagonal?

210. What is the length of a brace completing a triangle, each of the two sides of which is 57'' long?

211. What is the length of a brace completing a triangle, the sides of which are 6' and 8' long?

212. Allowing $2\frac{1}{2}$ tons per square foot for a safe load, what will a footing course $6' \times 6'$ carry upon a bottom of hard clay?

213. A load of 300,000 lb. is to be supported upon a gravel bed, which will safely carry 8 tons per square foot. What should be the area of the foot of the pier?

214. If a foundation is $25' \times 32'$, how large ought the bottom of the excavation to be to allow for a footing course and a tile drain?

215. What is the length of a brace completing a triangle, the sides of which are 9.295' and 14' long?

216. Which will have the more sectional area, an 8" \times 8" sill, with a 2" \times 4" and a 2" \times 2" mortise, or a 6" \times 8", with no mortising, and a 2" \times 4" spiked on to support floor joists, and how much greater?

217. If a girt is 8" \times 8", and 2 floor joists are mortised into it each with a 2" \times 4" tenon, what is the actual area of the girt?

218. What is the length of a brace completing a triangle each side of which is 4' 6" long?

219. What is the length of a balloon brace for sides 30" \times 12' long?

220. If a floor is well bridged, and a load of 12,000 lb. causes a deflection of $\frac{1}{16}$ ", what would be the deflection if the floor were not bridged?

221. What is the greatest square which can be contained in a 24" circle?

222. What will be the size of a square $\frac{1}{2}$ of the area of one measuring 10' upon each side?

223. What will be the diameter of a circle which will equal the area of two given circles, one 5' and the other 8' in diameter?

224. If an octagon is 5' upon one side, what is its width?

225. If a hexagon is 5' 11 $\frac{1}{4}$ " upon each side, what is its width?

226. What is the length of the diagonal of an octagon which is 5' upon a side?

227. What will be the rise of a half pitch roof, if the house is 28' wide?

NOTE.—In problems 228, 229, 230, estimate the width of the shingled area of each side of the roofs, to equal the next larger foot than the actual dimensions.

228. If the above roof has a projection of 18" and the house is 35' long, how many shingles will be needed to cover the roof, allowing 1000 per square, the rafters being 2' longer than the actual length?

229. A third pitch roof house 28' \times 36' 9", with a lookout of 18" horizontal projection, is to be covered with a steel roof at a cost of \$3 per square. What will it cost?

230. The roof of a quarter pitch house, 30' \times 28', with a lookout of 12" horizontal projection, is to be painted at a cost of \$1.25 per square. What will it cost?

231. What is the length of a rafter of a half pitch roof, if the house is 29' wide?

232. If the rafters are to be set 24'' to centers, how many will be required for a roof which is 40' long?

233. What will be the length of the common rafter of a half pitch roof if the house is 24' wide?

234. What will be the rise and run of the common rafter of a third pitch roof of a building 32' wide?

235. What will be the length of a common rafter of a two-thirds pitch roof if the house is 24' wide?

236. What will be the length of a common rafter of a third pitch roof of a house which is 27' wide?

237. If a hip roof is to be built upon a house which is 28' square, will there be any ridge?

238. If a hip roof house is 26' wide and 29' long, how long will the ridge be?

239. If a ridge 2' 11'' long extends to take the entire side cut of the hip rafters, what will be the entire length of it?

240. If a 1 $\frac{3}{8}$ '' ridge board is used, how much shorter will each end of the ridge be? Give the answer to the nearest $\frac{1}{2}$ of an inch.

241. A shed roof rises 12'' to 12'. Allowing 1' for lookouts, what will be the entire length of the rafter?

242. What will be the entire rise of the roof from eaves to eaves?

243. What will be the length of the lookouts of a half pitch roof, which projects 22''?

244. What will be the length of the hip rafter of a half pitch house 24' wide?

245. What will be the length of the hip rafter of a third pitch house 28' wide?

246. What will be the length of the hip rafter of a quarter pitch house 25' 11'' wide?

247. What will be the length of a hip lookout for a third pitch house, if the common rafters project 18''?

248. How much shorter will a quarter pitch hip rafter be cut if a 2'' ridge is used, the ridge taking the entire joint of the hip?

249. What will be the length of the collar beam for a half pitch house, if the bottom is placed 6' below the apex of the roof?

250. Find the same for a third pitch house.

251. Find the same for a fourth pitch house.
252. What will be the length of the strut which supports the common rafter of a quarter pitch roof? It is square with the rafter and 6 ft. from the end.
253. Find the same for a third pitch house.
254. Find the same for a quarter pitch house.
255. An octagonal tower is to be built, 6' upon each side. What is the parallel width of the tower?
256. What is the diagonal of the above tower?
257. What is the length of the hip rafter of the above tower, if it is 10' high at the apex?
258. If a 6'' king post is used, how much will each hip rafter be shortened?
259. The common rafters of the roof of an addition are to be cut to dimensions instead of an ordinary pitch. If the run of these rafters is 10' 7'', and the rise 6' 4'', what will be their length?
260. If a hexagonal tower 8' upon one side is to be built, what is its diagonal?
261. What will be the parallel width of the above tower?
262. What will be the length of the hip rafter if the above roof rises 12'?
263. If a circular roof 22' in diameter and 11' high is to be built, what will be the length of the first pair of rafters?
264. Find the length of the second pair.
265. Find the lengths of the third and fourth pairs.
266. What will be the length of the valley rafter of a third pitch house, which is 24' wide, an ell 20' wide joining the main house?
267. If a 2'' hip is used, how much shorter will the valley rafter be?
268. If the common rafters of a half pitch roof meet at the apex and jacks are to be 2' to centers, how much shorter will the first jack be than the common rafter?
269. Work out the same problem for a third pitch house.
270. If the center of the common rafter of a quarter pitch roof is 9'' away from the hip apex and 22'' from the center of the first jack, how much shorter will the jack be than the common rafters?
271. If the common rafter of a third pitch house is 12' long, and is set 8'' from the apex of the hip, what is the length of the first jack?

272. What will be the length of the longest jacks of an octagonal roof which is 18' wide between sides, with a rise of 12', if they are placed 2' 6'' on centers at the plate? In this case, the middle rafter of each side of the roof is not considered a jack.

273. If 2'' hips are used, how much shorter will the top ends of these rafters have to be cut?

274. The material costs twice as much as the labor upon a certain house which is to be built upon a hilltop. On account of the location it costs 5 per cent more to get the material, and since the men come from the city to the building, the increase of the cost of labor is 4 per cent. If the cost of the house in an ordinary locality would have been \$2100, what will be the cost of this house?

275. At \$1.37 $\frac{1}{2}$ per minimum day's work, what will it cost to excavate and wheel 60 ft. the earth from a cellar 30' \times 45', and 4' deep?

276. If a mason is paid \$3 per day, and a helper \$1.50, how much will it cost to build the rubble stone wall of a house, 25' \times 32' \times 16'' thick, and 8' high?

277. How many bushels of sand and lime will be required in building the above wall?

278. How much will it cost for labor upon a brick wall, 40' long, 25.014' high, 16'' thick, allowing $\frac{1}{3}$ for openings? The bricklayer lays the average number of bricks, and receives \$3 per day, and the helper \$1.50.

279. How many bushels of sand and lime will be necessary to lay 24,330 bricks?

280. How many studs will be necessary for the outside walls of a rectangular building 25' \times 40', 12 openings?

281. The joists of a floor 32' long \times 18' wide are set 16'' on centers, and the floor is strengthened by two rows of bridging, which costs 4 ct. per set. What is the cost of the bridging?

282. How much horizontal sheathing will it take to cover the walls of a hip roof building 27' 6'' \times 38' 3'', and 16' high to the eaves? Make no allowance for openings.

283. If the house is boarded diagonally, how much will it take? Make no allowance for openings.

284. A floor 20' \times 16' is to be laid of 4'' matched boards. How many feet will it take?

285. What will be the amount if 3'' boards are used?

286. How many square feet of 6" siding will be required to cover the walls of an octagonal auditorium 64.1' upon each side, and 20' high, with the usual number of windows?

287. How much 4" matched siding would be used for the above building?

288. If a cornice 26" wide is to be built upon this house, how much will it cost, estimating the size of the house as the length of the cornice?

NOTE. — Questions 289 to 300, inclusive, refer to labor only.

289. If it takes 6000 ft. of studding to build a house, how much will it cost to set it, if the minimum day's work is done with wages at \$2.25 per day?

290. If it takes 3000 ft. of rafters to frame a house, how much will it cost with labor at \$2.25 per day?

291. If it takes 3375 ft. of floor joists to frame the floors of a certain building, how much will the labor cost at \$2.50 per day?

292. If it takes 14,500 ft. of sheathing to cover a house, how much will it cost if the men receive \$1.75 per day?

293. If a house requires 6300 ft. of siding, how much will it cost if the men receive \$2.25 per day?

294. If a house requires 30,220 shingles, how much will it cost to lay them?

295. How much will it cost to set 28 window frames, at \$2.50 per day of 10 hours?

296. How much will it cost to put a ceiling wainscot around 6 rooms, aggregating 275' spread, and 3' 6" high, if the men receive \$2.50 per day, and do a maximum day's work?

297. 62 inside doors are to be hung and trimmed. If the wages are \$2.75 per day, and if mortise locks are used, how much will the job cost?

298. At \$8 per square, how much will it cost to put a tin roof upon a building which is 20' \times 36' with a projection of 12'?

299. What will it cost at \$.22 per square yard to lath and plaster 6 rooms, 12' \times 16', averaging 8' high?

300. If it takes 18 inch laths per square yard and labor costs \$2 per day, what will the labor cost to lath a house containing 387 sq. yd.?

301. If the cost of building figures up to \$2533, what will be the estimate after the hardware is added, allowing the minimum estimate?

302. If the hardware in a certain house cost \$73.80, how much will it cost to put it on?

303. How many gallons of paint will be necessary to cover (2 coats) a building which has a surface of 9000 sq. ft.?

304. If the paint for a building costs \$84, how much should the labor of putting it on cost? (See Section 69.)

305. How many gallons of paint are necessary to cover (2 coats) 4200 sq. ft., allowing $\frac{1}{5}$ for large openings?

306. A job of papering requires 67 double rolls. What will the cost of laying it be?

307. If a job of paperhanging requires 93 double rolls of paper, at 8¢ per roll, and it costs \$.12 $\frac{1}{2}$ per single roll to lay it, what will the job cost?

CHAPTER IX

TABLES

TABLE 1

ASPHALT FLOOR

6 parts asphalt.
1 part coal tar.
3 parts sand.

TABLE 2

BENDING

Radius $\times .05$ = thickness of pine which will bend without special preparation.

TABLE 3

CELLAR SASH

TWO-LIGHT SASH $1\frac{3}{8}$ " THICK		THREE-LIGHT SASH $1\frac{1}{8}$ " THICK	
Size of Glass	Size of Sash	Size of Glass	Size of Sash
10'' \times 12''	2' 1'' \times 16''	7'' \times 9''	2' 1'' \times 13''
10'' \times 14''	2' 1'' \times 18''	8'' \times 10''	2' 4'' \times 14''
10'' \times 16''	2' 1'' \times 20''	9'' \times 12''	2' 7'' \times 16''
10'' \times 18''	2' 1'' \times 22''	9'' \times 13''	2' 7'' \times 17''
12'' \times 12''	2' 5'' \times 16''	9'' \times 14''	2' 7'' \times 18''
12'' \times 14''	2' 5'' \times 18''	10'' \times 12''	2' 10'' \times 16''
12'' \times 16''	2' 5'' \times 20''	10'' \times 14''	2' 10'' \times 18''
12'' \times 18''	2' 5'' \times 22''	10'' \times 16''	2' 10'' \times 20''
12'' \times 20''	2' 5'' \times 24''	12'' \times 12''	3' 4'' \times 16''
14'' \times 16''	2' 9'' \times 20''	12'' \times 14''	3' 4'' \times 18''
14'' \times 18''	2' 9'' \times 22''	12'' \times 16''	3' 4'' \times 20''
14'' \times 20''	2' 9'' \times 24''		
14'' \times 22''	2' 9'' \times 26''		
14'' \times 24''	2' 9'' \times 28''		

TABLE 4
SIZES AND WEIGHTS OF WINDOWS

SIZE OF GLASS	SIZE OF WINDOW ¹				WEIGHT OF WINDOW — GLAZED			
	2-light	4-light	8-light	12-light	2-light	4-light	8-light	12-light
8 X 12				2' 4 1/2" X 4' 6"				20 lb.
8 X 14				2' 4 1/2" X 5' 2"				22 lb.
9 X 12			1' 11" X 4' 6"	2' 7 1/2" X 4' 6"			17 lb.	22 lb.
9 X 14			1' 11" X 5' 2"	2' 7 1/2" X 5' 2"			18 lb.	24 lb.
9 X 16			1' 11" X 5' 10"	2' 7 1/2" X 5' 10"			19 lb.	27 lb.
10 X 12			2' 1" X 4' 6"	2' 10 1/2" X 4' 6"			18 lb.	23 lb.
10 X 14			2' 1" X 5' 2"	2' 10 1/2" X 5' 2"			19 lb.	26 lb.
10 X 16			2' 1" X 5' 10"	2' 10 1/2" X 5' 10"			22 lb.	29 lb.
10 X 18			2' 1" X 6' 6"	2' 10 1/2" X 6' 6"			24 lb.	32 lb.
12 X 14			2' 5" X 5' 2"	2' 3' 4 1/2" X 5' 2"			23 lb.	
12 X 16			2' 5" X 5' 10"	2' 3' 4 1/2" X 5' 10"			24 lb.	
12 X 18			2' 5" X 6' 6"	2' 3' 4 1/2" X 6' 6"			27 lb.	
12 X 20		2' 5" X 4' 2"	2' 5" X 7' 2"	2' 3' 4 1/2" X 7' 2"			32 lb.	
14 X 20		2' 9" X 3' 10"	2' 9" X 7' 2"				35 lb.	
14 X 24		2' 9" X 4' 6"	2' 9" X 8' 6"				40 lb.	
10 X 24		2' 1" X 4' 6"						
10 X 28		2' 1" X 5' 2"						
10 X 32		2' 1" X 5' 10"						
12 X 30		2' 5" X 5' 6"						
12 X 32		2' 5" X 5' 10"						
12 X 36		2' 5" X 6' 6"						
12 X 40		2' 5" X 7' 2"						
14 X 30		2' 9" X 5' 6"						
14 X 34		2' 9" X 6' 2"						
14 X 36		2' 9" X 6' 6"						

D. S.² S. S.³
 23 lb. 21 lb.
 25 lb. 22 lb.
 26 lb. 23 lb.
 26 lb. 24 lb.
 28 lb. 25 lb.
 30 lb. 27 lb.
 33 lb. 29 lb.
 29 lb. 26 lb.
 32 lb. 27 lb.
 33 lb. 29 lb.

SIZE OF GLASS	SIZE OF WINDOW ¹			WEIGHT OF WINDOW—GLAZED						
	2-light	4-light	8-light	12-light		2-light		4-light	8-light	12-light
						D.	S.			
14 X 40		2'9" X 7' 2"						35 lb.	31 lb.	
14 X 44		2'9" X 7' 10"						37 lb.	33 lb.	
14 X 48		2'9" X 8' 6"						40 lb.	35 lb.	
20 X 24	2'0 1/2" X 4' 6"						23 lb.	21 lb.		
20 X 28	2'0 1/2" X 5' 2"						25 lb.	22 lb.		
20 X 32	2'0 1/2" X 5' 10"						26 lb.	23 lb.		
20 X 36	2'0 1/2" X 6' 6"						28 lb.	25 lb.		
20 X 40	2'0 1/2" X 7' 2"						30 lb.	26 lb.		
24 X 30	2'4 1/2" X 5' 6"						26 lb.	24 lb.		
24 X 32	2'4 1/2" X 5' 10"						28 lb.	25 lb.		
24 X 36	2'4 1/2" X 6' 6"						30 lb.	27 lb.		
24 X 40	2'4 1/2" X 7' 2"						33 lb.	29 lb.		
26 X 30	2'6 1/2" X 4' 10"						28 lb.	25 lb.		
26 X 34	2'6 1/2" X 6' 2"						31 lb.	27 lb.		
26 X 36	2'6 1/2" X 6' 6"						32 lb.	28 lb.		
26 X 40	2'6 1/2" X 7' 2"						34 lb.	30 lb.		
26 X 44	2'6 1/2" X 7' 10"						36 lb.	32 lb.		
26 X 48	2'6 1/2" X 8' 6"						39 lb.	34 lb.		
28 X 32	2'8 1/2" X 5' 10"						32 lb.	28 lb.		
28 X 36	2'8 1/2" X 6' 6"						34 lb.	30 lb.		
28 X 40	2'8 1/2" X 7' 2"						36 lb.	32 lb.		
28 X 44	2'8 1/2" X 7' 10"						38 lb.	34 lb.		
28 X 48	2'8 1/2" X 8' 6"						40 lb.	36 lb.		

¹ Furnished by Chicago dealers. To find the sizes furnished by Boston dealers, subtract from the above figures for a 2-light window 1/8" in width, 1" in height; for a 4-light window 1 1/4" in width, 1" in height; for an 8-light window the same; for a 12-light window 7/8" in width, 1" in height. The thickness of the sash is 1 1/8" throughout.

² Double strength.

³ Single strength.

TABLE 5

PAINTING

To remove old paint : Dissolve 2 oz. of soft soap, 4 oz. of potash in boiling water ; add $\frac{1}{2}$ lb. of quicklime. Apply hot, and leave from 12 to 24 hours ; wash off with hot water.

To dip 1000 shingles a third of their length, requires $2\frac{3}{4}$ gal. of stain.

1 lb. of paint covers $3\frac{1}{2}$ to 4 sq. yd., the first coat ; $4\frac{1}{2}$ to 6 sq. yd. for each succeeding coat.

On brick 1 lb. of paint covers 3 sq. yd. the first coat, and 4 sq. yd. for each succeeding coat.

Colored paint covers about a third more than white.

1 gal. of paint will cover 250 to 300 sq. ft. two coats.

1 gal. of paint will cover 300 to 350 sq. ft. of metal, one coat.

1 gal. of paint weighs about 16 lb.

1 gal. of shingle stain will cover 200 sq. ft. or dip about 400 shingles.

Rough-sawed shingles require 50 per cent more stain than smooth.

1 lb. of cold water paint covers 50 to 75 sq. ft. for first coat on wood, or 40 ft. on brick or stone.

1 gal. of filler covers 300 to 400 sq. ft. the first coat, and 400 to 500 sq. ft. for succeeding coats. 10 lb. of paste filler will cover from 350 to 400 sq. ft.

1 gal. of varnish weighs 8 to 9 lb.

1 gal. of turpentine weighs 7 lb.

1 gal. of linseed oil weighs $7\frac{3}{4}$ lb.

5 lb. of putty will be required to putty 100 sq. yd. of ordinary surface.

Sizing ; $\frac{1}{2}$ lb. of glue to 1 gal. of water.

Priming coat ; 100 lb. of white lead, 7 gal. oil, $\frac{3}{4}$ gal. of japan drier.

Second coat ; 100 lb. of white lead, 7 gal. oil.

Third coat ; 100 lb. of white lead, $6\frac{1}{2}$ to 7 gal. of oil.

Three gal. of boiled oil to 2 gal. of raw oil for outside work.

Upon plain work the labor costs about $1\frac{1}{2}$ times the material.

Stippling costs about the same as two coats of paint.

TABLE 6

WALL PAPER

Double roll ; 16 yd. long, 18'' or 20'' wide.

Cartridge or felt papers ; 30'' wide, 16 yd. to a roll.

The usual cost of papering is from $12\frac{1}{2}$ to 25 ¢ per double roll lapped, and from 50 to 75 ¢, for glazed paper. Butted paper costs from 10 to 15 ¢ more per double roll ; in large cities the prices are generally from 20 to 40 per cent higher than those given above.

TABLE 7

PLASTERING (QUANTITIES FOR 100 Sq. Yd.)

1440 laths, 1½".	½ bbl. of plaster of Paris.
10 lb. nails.	Labor; plasterer 3¼ days.
Labor lathing, 1 day.	helper 2½ days.
3-coat work.	2-coat work.
13 bu. of lime.	10 bu. lime.
1 bu. of hair.	¾ bu. of hair.
1½ load of sand.	1 load of sand.
	¼ bbl. of plaster of Paris.

TABLE 8

SHINGLES

1000 WILL COVER			NUMBER OF SHINGLES REQUIRED TO LAY ONE SQUARE	
To Weather	4" Wide	6" Wide	4" Wide	6" Wide
4"	111 sq. ft.	167 sq. ft.	900	600
5"	139 sq. ft.	208 sq. ft.	720	480
6"	167 sq. ft.	250 sq. ft.	600	400
7"	194 sq. ft.	291 sq. ft.	514	343
8"	222 sq. ft.	333 sq. ft.	450	300

TABLE 9

NUMBER OF SLATES REQUIRED PER SQUARE

SIZE	NUMBER	SIZE	NUMBER	SIZE	NUMBER
6" × 12"	553	9" × 16"	246	14" × 20"	121
7" × 12"	457	10" × 16"	221	11" × 22"	138
8" × 12"	400	9" × 18"	213	12" × 22"	126
9" × 12"	355	10" × 18"	192	13" × 22"	116
7" × 14"	374	11" × 18"	174	14" × 22"	108
8" × 14"	327	12" × 18"	160	12" × 24"	114
9" × 14"	291	10" × 20"	169	13" × 24"	105
10" × 14"	261	11" × 20"	154	14" × 24"	98
8" × 16"	277	12" × 20"	141	16" × 24"	86

TABLE 10

SIZES OF NAILS AND NUMBER PER POUND

SIZE	LENGTH IN INCHES	NUMBER PER POUND			
		Common	Finishing	Casing	Flooring
2d	1	860	1558	1140
3d Fine	1 $\frac{1}{8}$
3d Com.	1 $\frac{1}{4}$	594	884	675
	1 $\frac{3}{8}$
4d	1 $\frac{1}{2}$	339	767	567
5d	1 $\frac{3}{4}$	230	491	396
6d	2	205	359	260	151
7d	2 $\frac{1}{4}$	135	317	239	136
8d	2 $\frac{1}{2}$	96	214	160	98
9d	2 $\frac{3}{4}$	92	195	148	86
10d	3	63	134	108	66
12d	3 $\frac{1}{4}$	52	120	99	51
16d	3 $\frac{1}{2}$	38	91	69	40
20d	4	30	61	50	29
30d	4 $\frac{1}{2}$	23	45
40d	5	17	35
50d	5 $\frac{1}{2}$	13 $\frac{1}{2}$
60d	6	10 $\frac{1}{2}$

TABLE 11

NUMBER OF NAILS REQUIRED

Shingles, per M.	5 lb.	4d com.
Laths, per M.	7 lb.	3d com.
Beveled siding, per M.	18 lb.	6d com.
Sheathing, per M.	{ 20 lb. or	8d com.
	{ 25 lb.	10d com.
Flooring, rough, per M.	{ 30 lb. or	8d com.
	{ 40 lb.	10d com.
Studding, per M.	{ 15 lb. or	10d com.
	{ 5 lb.	20d com.
Furring, per M.	10 lb.	10d com.
Finished flooring, per M.	{ 20 lb. or	8d & 10d fin.
	{ 1 $\frac{1}{8}$ "	10d fin.

TABLE 12
CHIMNEYS

NUMBER OF FLUE	SIZE OF FLUE	SIZE OF CHIMNEY	NUMBER OF BRICKS PER FOOT IN HEIGHT ¹
1	8" × 8"	16" × 16"	30
1	8" × 16"	16" × 24"	40
2	8" × 8"	16" × 28"	50
3	8" × 8"	16" × 40"	70
4	8" × 8"	16" × 52"	90
1	12" × 12"	20" × 20"	40
1	12" × 16"	20" × 24"	45

¹ Five courses of brick to a foot in height.

TABLE 13

STABLES ; MISCELLANEOUS INFORMATION

1200 cu. ft. per horse. (The U. S. Army allows 1500.)

16' 6" width of building for one stall.

29' 0" width of building for two stalls.

Box stalls: 12' 0" × 12' 0".

Single stalls: 9' 6" × 6' 2". Stalls are sometimes made as narrow as 4' 0", but only where space is very valuable.

A stall floor should not slant more than 1½" in its length.

Stall divisions should be 4' 6" high in the rear, 7' 0" at the head.

There should be 9 sq. ft. of glass space for each horse.

There should be ventilating shafts which will allow 18 inches square for each horse.

Doors should either slide, or open outwards.

TABLE 14

SIZES OF BOXES FOR DIFFERENT MEASURES

LENGTH INCHES	WIDTH INCHES	DEPTH INCHES	CAPACITY	LENGTH INCHES	WIDTH INCHES	DEPTH INCHES	CAPACITY
48	41	32	1 ton of coal.	8½	8	8	1 peck.
24	17	28	1 bbl. or 3 bu.	8	8	4½	1 gallon.
24	17	14	½ bbl.	7	7	2¾	½ gallon.
16	16	8½	1 bushel.	4	4	4½	1 quart.
16	8	8½	½ bu.	3	3	3½	1 pint.

TABLE 15. DIAMETERS, AREAS, AND CIRCUMFERENCES OF CIRCLES

DIAM.	AREA	CIR.	DIAM.	AREA	CIR.	DIAM.	AREA	CIR.
	0.0123	.3927	16	201.06	50.26	54	2290.2	169.6
	0.0491	.7854	$\frac{1}{2}$	213.82	51.83	55	2375.8	172.8
	0.1104	1.178	17	226.98	53.40	56	2463.0	175.9
	0.1963	1.571	$\frac{1}{2}$	240.53	54.98	57	2551.8	179.1
	0.3068	1.963	18	254.47	56.55	58	2642.1	182.2
	0.4418	2.356	$\frac{1}{2}$	268.80	58.12	59	2734.0	185.3
	0.6013	2.741	19	283.53	59.69	60	2827.4	188.5
1	0.7854	3.142	$\frac{1}{2}$	298.65	61.26	61	2922.5	191.6
	0.9940	3.534	20	314.16	62.83	62	3019.1	194.8
	1.227	3.927	$\frac{1}{2}$	330.06	64.40	63	3117.2	197.9
	1.485	4.319	21	346.36	65.97	64	3217.0	201.0
	1.767	4.712	$\frac{1}{2}$	363.05	67.54	65	3318.3	204.2
	2.074	5.105	22	380.13	69.11	66	3421.2	207.3
	2.405	5.498	$\frac{1}{2}$	397.61	70.68	67	3525.7	210.5
	2.761	5.890	23	415.48	72.25	68	3631.7	213.6
2	3.142	6.283	$\frac{1}{2}$	433.73	73.83	69	3739.3	216.7
	3.976	7.068	24	452.39	75.40	70	3848.5	219.9
	4.909	7.854	$\frac{1}{2}$	471.43	76.97	71	3959.2	223.0
	5.939	8.639	25	490.87	78.54	72	4071.5	226.2
3	7.068	9.425	26	530.93	81.68	73	4185.4	229.3
	8.296	10.21	27	572.56	84.82	74	4300.8	232.5
	9.621	10.99	28	615.75	87.96	75	4417.9	235.6
	11.044	11.78	29	660.52	91.10	76	4536.5	238.7
4	12.566	12.56	30	706.86	94.25	77	4656.7	241.9
	15.904	14.14	31	754.77	97.39	78	4778.4	245.0
5	19.635	15.71	32	804.25	100.5	79	4901.7	248.2
	23.758	17.23	33	855.30	103.6	80	5026.6	251.3
6	28.274	18.85	34	907.92	106.8	81	5153.0	254.5
	33.183	20.42	35	962.11	109.9	82	5281.0	257.6
7	38.484	21.99	36	1017.9	113.1	83	5410.6	260.7
	44.179	23.56	37	1075.2	116.2	84	5541.8	263.9
8	50.265	25.13	38	1134.1	119.4	85	5674.5	267.0
	56.745	26.70	39	1194.6	122.5	86	5808.8	270.2
9	63.617	28.27	40	1256.6	125.6	87	5944.7	273.3
	70.882	29.84	41	1320.2	128.8	88	6082.1	276.4
10	78.54	31.41	42	1385.4	131.9	89	6221.1	279.6
	86.59	32.98	43	1452.2	135.1	90	6361.7	282.7
11	95.03	34.55	44	1520.5	138.2	91	6503.9	285.9
	103.87	36.13	45	1590.4	141.4	92	6647.6	289.0
12	113.10	37.70	46	1661.9	144.5	93	6792.9	292.2
	122.72	39.27	47	1734.9	147.6	94	6939.8	295.3
13	132.73	40.84	48	1809.6	150.8	95	7088.2	298.4
	143.14	42.41	49	1885.7	153.9	96	7238.2	301.6
14	153.94	43.98	50	1963.5	157.1	97	7389.8	304.7
	165.13	45.55	51	2042.8	160.2	98	7543.0	307.9
15	176.71	47.12	52	2123.7	163.3	99	7697.7	311.0
	188.69	48.69	53	2206.2	166.5	100	7854.0	314.2

To find the circumference and area of any diameter *greater* than any in the preceding table. *Rule.* — Multiply any diameter given above by the factor 2, 3, 4, or 5, etc., the product of which will be the diameter whose circumference and area are wanted. *Example.* — What is the circumference of 140? Tabular diameter of $35 \times 4 = 140$. Tabular circumference of $35 = 109.9 \times 4 = 439.6$, circumference wanted. *Rule for the Area.* — Multiply the tabular area of tabular diameter by the *square* of the factor. *Example.* — What is the area of 140? Tabular area of $35 = 962.11 \times 16$ (is the square of the factor 4) = 15,393.76, area wanted. *The Circle.* — The circumference of a circle is equal to the diameter multiplied by 3.1416. The area of a circle is equal to the square of the diameter multiplied by .7854.

TABLE 16

DECIMAL EQUIVALENTS OF A LINEAR FOOT

LINEAR INCHES	LINEAR FOOT	LINEAR INCHES	LINEAR FOOT	LINEAR INCHES	LINEAR FOOT
$\frac{1}{64}$	0.001302083	$\frac{7}{8}$	0.15625	$6\frac{1}{2}$	0.5416
$\frac{1}{32}$	0.00260416	2	0.1666	$6\frac{3}{4}$	0.5625
$\frac{1}{16}$	0.0052083	$2\frac{1}{8}$	0.177083	7	0.5833
$\frac{1}{8}$	0.010416	$2\frac{1}{4}$	0.1875	$7\frac{1}{4}$	0.60416
$\frac{3}{16}$	0.015625	$2\frac{3}{8}$	0.197916	$7\frac{1}{2}$	0.625
$\frac{1}{4}$	0.02083	$2\frac{1}{2}$	0.2083	$7\frac{3}{4}$	0.64583
$\frac{5}{16}$	0.0260416	$2\frac{5}{8}$	0.21875	8	0.66667
$\frac{3}{8}$	0.03125	$2\frac{3}{4}$	0.22916	$8\frac{1}{4}$	0.6875
$\frac{7}{16}$	0.0364583	$2\frac{7}{8}$	0.239583	$8\frac{1}{2}$	0.7083
$\frac{1}{2}$	0.0416	3	0.25	$8\frac{3}{4}$	0.72916
$\frac{9}{16}$	0.046875	$3\frac{1}{4}$	0.27083	9	0.75
$\frac{5}{8}$	0.052083	$3\frac{1}{2}$	0.2916	$9\frac{1}{4}$	0.77083
$\frac{11}{16}$	0.0572916	$3\frac{3}{4}$	0.3125	$9\frac{1}{2}$	0.7916
$\frac{3}{4}$	0.0625	4	0.33333	$9\frac{3}{4}$	0.8125
$\frac{13}{16}$	0.0677083	$4\frac{1}{4}$	0.35416	10	0.83333
$\frac{7}{8}$	0.072916	$4\frac{1}{2}$	0.375	$10\frac{1}{4}$	0.85416
$\frac{15}{16}$	0.078125	$4\frac{3}{4}$	0.39583	$10\frac{1}{2}$	0.875
1	0.0833	5	0.4166	$10\frac{3}{4}$	0.89583
$1\frac{1}{8}$	0.09375	$5\frac{1}{4}$	0.4375	11	0.9166
$1\frac{1}{4}$	0.10416	$5\frac{1}{2}$	0.4583	$11\frac{1}{4}$	0.9375
$1\frac{3}{8}$	0.114583	$5\frac{3}{4}$	0.47916	$11\frac{1}{2}$	0.9583
$1\frac{1}{2}$	0.125	6	0.5	$11\frac{3}{4}$	0.97916
$1\frac{5}{8}$	0.135416	$6\frac{1}{4}$	0.52083	12	1.000
$1\frac{3}{4}$	0.14583

TABLE 17

DECIMAL EQUIVALENTS OF THE FRACTIONAL PARTS OF AN INCH

1-640156	33-645156
1-320313	17-325313
3-640469	35-645469
1-160625	9-165625
5-640781	37-645781
3-320938	19-325938
7-641094	39-646094
1-8125	5-8625
9-641406	41-646406
5-321563	21-326563
11-641719	43-646719
3-161875	11-166875
13-642031	45-647031
7-322188	23-327188
15-642344	47-647344
1-425	3-475
17-642656	49-647656
9-322813	25-327813
19-642969	51-647969
5-163125	13-168125
21-643281	53-648281
11-323438	27-328438
23-643594	55-648594
3-8375	7-8875
25-643906	57-648906
13-324063	29-329063
27-644219	59-649219
7-164375	15-169375
29-644531	61-649531
15-324688	31-329688
31-644844	63-649844
1-25	1	1

TABLE 18
CONTENTS OF ROUND TANKS IN GALLONS

DIAMETER		GALLONS 1 FOOT DEPTH	DIAMETER		GALLONS 1 FOOT DEPTH	DIAMETER		GALLONS 1 FOOT DEPTH
Feet	Inches		Feet	Inches		Feet	Inches	
4		93.97	9	3	502.55	17	9	1850.53
4	1	97.93	9	6	530.08			
4	2	101.97	9	9	558.35	18		1903.02
4	3	103.03				18	3	1956.25
4	4	110.29	10		587.35	18	6	2010.21
4	5	114.57	10	3	617.08	18	9	2064.91
4	6	118.93	10	6	647.55			
4	7	123.38	10	9	678.27	19		2120.34
4	8	127.91				19	3	2176.51
4	9	132.52	11		710.69	19	6	2233.29
4	10	137.21	11	3	743.36	19	9	2291.04
4	11	142.05	11	6	776.77			
			11	9	810.91	20		2349.41
5		146.83				20	3	2408.51
5	1	151.77	12		848.18	20	6	2468.35
5	2	156.78	12	3	881.39	20	9	2528.92
5	3	161.88	12	6	917.73			
5	4	167.06	12	9	954.81	21		2590.22
5	5	172.33				21	3	2652.25
5	6	177.67	13		992.62	21	6	2715.04
5	7	183.09	13	3	1031.17	21	9	2778.54
5	8	188.60	13	6	1070.45			
5	9	194.19	13	9	1108.06	22		2842.79
5	10	199.86				22	3	2907.76
5	11	205.61	14		1151.21	22	6	2973.48
			14	3	1192.69	22	9	3039.92
6		211.44	14	6	1234.91			
6	3	229.43	14	9	1277.86	23		3107.10
6	6	248.15				23	3	3175.01
6	9	267.61	15		1321.54	23	6	3243.65
			15	3	1365.96	23	9	3313.04
7		287.80	15	6	1407.51			
7	3	308.72	15	9	1457.00	24		3383.15
7	6	330.38				24	3	3454.00
7	9	352.76	16		1503.62	24	6	3525.59
			16	3	1550.97	24	9	3597.90
8		375.90	16	6	1599.06			
8	3	399.76	16	9	1647.89	25		3670.95
8	6	424.36				25	3	3744.74
8	9	449.21	17		1697.45	25	6	3819.26
			17	3	1747.74	25	9	3894.52
9		475.75	17	6	1798.76			

TABLE 19
WEIGHTS AND SPECIFIC GRAVITIES

BUILDING MATERIALS	WEIGHT IN LB. PER CU. FT.	SPECIFIC GRAV- ITY
Ash (all woods kiln dried)	36 to 42	.60 to .70
Brick, common	100	1.60
pressed	150	2.40
Cement, Portland	80 to 100	1.44
Rosendale	56	.89
Cherry	36 to 42	.672
Chestnut	24 to 30	.40 to .50
Coal, bituminous, broken	50	.80
Coke	28	.37 to .51
Cypress	24 to 30	.40 to .50
Earth, dry, loose	72 to 80	1.36
rammed	90 to 100	1.52
moist, loose	67 to 75	1.31
packed	90 to 100	1.74
soft mud	104 to 120	2.09
Elm, best	42 to 48	.70 to .80
Glass, common	157 to 186	2.52
Granite	170	2.72
Hemlock	24 to 30	.40 to .50
Hickory	42 to 48	.70 to .80
Ice	57.4	.92
Iron, cast	450	7.21
wrought	480	7.69
Lead	710	11.38
Lime	70	.80
Locust, black	42 to 48	.70 to .80
Mahogany	35 to 53	.56 to .85
Maple	36 to 42	.60 to .70
Masonry, granite or limestone	165	2.65
rubble	125 to 140	2.21
Mortar	103	1.65
Oak, white	42 to 48	.70 to .80
Pine, white	18 to 24	.30 to .40
yellow	30 to 36	.50 to .60
Poplar	18 to 24	.30 to .40
Sand, dry	90 to 106	1.80
wet	118 to 129	2.19
Spruce	24 to 30	.40 to .50
Steel	490	7.85
Sycamore	30 to 36	.50 to .60
Walnut, black	36 to 42	.60 to .70

NOTE. — Green timber will usually weigh from 20 per cent to 40 per cent more than the above given weights. Weather dried timber will generally weigh about 15 per cent to 20 per cent more.

TABLE 20

SQUARES, CUBES, SQUARE ROOTS, CUBE ROOTS

NUMBER	SQUARE	CUBE	SQUARE ROOT	CUBE ROOT
1	1	1	1.0000000	1.0000000
2	4	8	1.4142136	1.2599210
3	9	27	1.7320508	1.4422496
4	16	64	2.0000000	1.5874011
5	25	125	2.2360680	1.7099759
6	36	216	2.4494897	1.8171206
7	49	343	2.6457513	1.9129312
8	64	512	2.8284271	2.0000000
9	81	729	3.0000000	2.0800837
10	100	1000	3.1622777	2.1544347
11	121	1331	3.3166248	2.2239801
12	144	1728	3.4641016	2.2894286
13	169	2197	3.6055513	2.3513347
14	196	2744	3.7416574	2.4101422
15	225	3375	3.8729833	2.4662121
16	256	4096	4.0000000	2.5198421
17	289	4913	4.1231056	2.5712816
18	324	5832	4.2426407	2.6207414
19	361	6859	4.3588989	2.6684016
20	400	8000	4.4721360	2.7144177
21	441	9261	4.5825757	2.7589243
22	484	10648	4.6904158	2.8020393
23	529	12167	4.7958315	2.8438670
24	576	13824	4.8989795	2.8844991
25	625	15625	5.0000000	2.9240177
26	676	17576	5.0990195	2.9624960
27	729	19683	5.1961524	3.0000000
28	784	21952	5.2915026	3.0365889
29	841	24389	5.3851648	3.0723168
30	900	27000	5.4772256	3.1072325
31	961	29791	5.5677644	3.1413806
32	1024	32768	5.6568542	3.1748021
33	1089	35937	5.7445626	3.2075343
34	1156	39304	5.8309519	3.2396118
35	1225	42875	5.9160798	3.2710663
36	1296	46656	6.0000000	3.3019272
37	1369	50653	6.0827625	3.3322218
38	1444	54872	6.1644140	3.3619754
39	1521	59319	6.2449980	3.3912114
40	1600	64000	6.3245553	3.4199519

SQUARES, CUBES, SQUARE ROOTS, CUBE ROOTS — *Continued*

NUMBER	SQUARE	CUBE	SQUARE ROOT	CUBE ROOT
41	1681	68921	6.4031242	3.4482172
42	1764	74088	6.4807407	3.4760266
43	1849	79507	6.5574385	3.5033981
44	1936	85184	6.6332496	3.5303483
45	2025	91125	6.7082039	3.5568933
46	2116	97336	6.7823300	3.5830479
47	2209	103823	6.8556546	3.6088261
48	2304	110592	6.9282032	3.6342411
49	2401	117649	7.0000000	3.6593057
50	2500	125000	7.0710678	3.6840314
51	2601	132651	7.1414284	3.7084298
52	2704	140608	7.2111026	3.7325111
53	2809	148877	7.2801099	3.7562858
54	2916	157464	7.3484692	3.7797631
55	3025	166375	7.4161985	3.8029525
56	3136	175616	7.4833148	3.8258624
57	3249	185193	7.5498344	3.8485011
58	3364	195112	7.6157731	3.8708766
59	3481	205379	7.6811457	3.8929965
60	3600	216000	7.7459667	3.9148676
61	3721	226981	7.8102497	3.9364972
62	3844	238328	7.8740079	3.9578915
63	3969	250047	7.9372539	3.9790571
64	4096	262144	8.0000000	4.0000000
65	4225	274625	8.0622577	4.0207256
66	4356	287496	8.1240384	4.0412401
67	4489	300763	8.1853528	4.0615480
68	4624	314432	8.2462113	4.0816551
69	4761	328509	8.3066239	4.1015661
70	4900	343000	8.3666003	4.1212853
71	5041	357911	8.4261498	4.1408178
72	5184	373248	8.4852814	4.1601676
73	5329	389017	8.5440037	4.1793390
74	5476	405224	8.6023253	4.1983364
75	5625	421875	8.6602540	4.2171633
76	5776	438976	8.7177979	4.2358236
77	5929	456533	8.7749644	4.2543210
78	6084	474552	8.8317609	4.2726586
79	6241	493039	8.8881944	4.2908404
80	6400	512000	8.9442719	4.3088695
81	6561	531441	9.0000000	4.3267487

SQUARES, CUBES, SQUARE ROOTS, CUBE ROOTS — *Continued*

NUMBER	SQUARE	CUBE	SQUARE ROOT	CUBE ROOT
82	6724	551368	9.0553851	4.3444815
83	6889	571787	9.1104336	4.3620707
84	7056	592704	9.1651514	4.3795191
85	7225	614125	9.2195445	4.3968296
86	7396	636056	9.2736185	4.4140049
87	7569	658503	9.3273791	4.4310476
88	7744	681472	9.3808315	4.4479602
89	7921	704969	9.4339811	4.4647451
90	8100	729000	9.4868330	4.4814047
91	8281	753571	9.5393920	4.4979414
92	8464	778688	9.5916630	4.5143574
93	8649	804357	9.6436508	4.5306549
94	8836	830584	9.6953597	4.5468359
95	9025	857375	9.7467943	4.5629026
96	9216	884736	9.7979590	4.5788570
97	9409	912673	9.8488578	4.5947009
98	9604	941192	9.8994949	4.6104363
99	9801	970299	9.9498744	4.6260650
100	10000	1000000	10.0000000	4.6415888
101	10201	1030301	10.0498756	4.6570095
102	10404	1061208	10.0995049	4.6723287
103	10609	1092727	10.1488916	4.6875482
104	10816	1124864	10.1980390	4.7026694
105	11025	1157625	10.2469508	4.7176940
106	11236	1191016	10.2956301	4.7326235
107	11449	1225043	10.3440804	4.7474594
108	11664	1259712	10.3923048	4.7622032
109	11881	1295029	10.4403065	4.7768562
110	12100	1331000	10.4880885	4.7914199
111	12321	1367631	10.5356538	4.8058955
112	12544	1404928	10.5830052	4.8202845
113	12769	1442897	10.6301458	4.8345881
114	12996	1481544	10.6770783	4.8488076
115	13225	1520875	10.7238053	4.8629442
116	13456	1560896	10.7703296	4.8769990
117	13689	1601613	10.8166538	4.8909732
118	13924	1643032	10.8627805	4.9048681
119	14161	1685159	10.9087121	4.9186847
120	14400	1728000	10.9544512	4.9324242
121	14641	1771561	11.0000000	4.9460874
122	14884	1815848	11.0453610	4.9596757

SQUARES, CUBES, SQUARE ROOTS, CUBE ROOTS—*Continued*

NUMBER	SQUARE	CUBE	SQUARE ROOT	CUBE ROOT
123	15129	1860867	11.0905365	4.9731898
124	15376	1906624	11.1355287	4.9866310
125	15625	1953125	11.1803399	5.0000000
126	15876	2000376	11.2249722	5.0132979
127	16129	2048383	11.2694277	5.0265257
128	16384	2097152	11.3137085	5.0396842
129	16641	2146689	11.3578167	5.0527743
130	16900	2197000	11.4017543	5.0657970
131	17161	2248091	11.4455231	5.0787531
132	17424	2299968	11.4891253	5.0916434
133	17689	2352637	11.5325626	5.1044687
134	17956	2406104	11.5758369	5.1172299
135	18225	2460375	11.6189500	5.1299278
136	18496	2515456	11.6619038	5.1425632
137	18769	2571353	11.7046999	5.1551367
138	19044	2628072	11.7473401	5.1676493
139	19321	2685619	11.7898261	5.1801015
140	19600	2744000	11.8321596	5.1924941
141	19881	2803221	11.8743421	5.2048279
142	20164	2863288	11.9163753	5.2171034
143	20449	2924207	11.9582607	5.2293215
144	20736	2985984	12.0000000	5.2414828
145	21025	3048625	12.0415946	5.2535879
146	21316	3112136	12.0830460	5.2656374
147	21609	3176523	12.1243557	5.2776321
148	21904	3241792	12.1655251	5.2895725
149	22201	3307949	12.2065556	5.3014592
150	22500	3375000	12.2474487	5.3132928
151	22801	3442951	12.2882057	5.3250740
152	23104	3511808	12.3288280	5.3368033
153	23409	3581577	12.3693169	5.3484812
154	23716	3652264	12.4096736	5.3601084
155	24025	3723875	12.4498996	5.3716854
156	24336	3796416	12.4899960	5.3832126
157	24649	3869893	12.5299641	5.3946907
158	24964	3944312	12.5698051	5.4061202
159	25281	4019679	12.6095202	5.4175015
160	25600	4096000	12.6491106	5.4288352
161	25921	4173281	12.6885775	5.4401218
162	26244	4251528	12.7279221	5.4513618
163	26569	4330747	12.7671453	5.4625556

SQUARES, CUBES, SQUARE ROOTS, CUBE ROOTS—*Continued*

NUMBER	SQUARE	CUBE	SQUARE ROOT	CUBE ROOT
164	26896	4410944	12.8062485	5.4737037
165	27225	4492125	12.8452326	5.4848066
166	27556	4574296	12.8840987	5.4958647
167	27889	4657463	12.9228480	5.5068784
168	28224	4741632	12.9614814	5.5178484
169	28561	4826809	13.0000000	5.5287748
170	28900	4913000	13.0384048	5.5396583
171	29241	5000211	13.0766968	5.5504991
172	29584	5088448	13.1148770	5.5612978
173	29929	5177717	13.1529464	5.5720546
174	30276	5268024	13.1909060	5.5827702
175	30625	5359375	13.2287566	5.5934447
176	30976	5451776	13.2664992	5.6040787
177	31329	5545233	13.3041347	5.6146724
178	31684	5639752	13.3416641	5.6252263
179	32041	5735339	13.3790882	5.6357408
180	32400	5832000	13.4164079	5.6462162
181	32761	5929741	13.4536240	5.6566528
182	33124	6028568	13.4907376	5.6670511
183	33489	6128487	13.5277493	5.6774114
184	33856	6229504	13.5646600	5.6877340
185	34225	6331625	13.6014705	5.6980192
186	34596	6434856	13.6381817	5.7082675
187	34969	6539203	13.6747943	5.7184791
188	35344	6644672	13.7113092	5.7286543
189	35721	6751269	13.7477271	5.7387936
190	36100	6859000	13.7840488	5.7488971
191	36481	6967871	13.8202750	5.7589652
192	36864	7077888	13.8564065	5.7689982
193	37249	7189057	13.8924440	5.7789966
194	37636	7301384	13.9283883	5.7889604
195	38025	7414875	13.9642400	5.7988900
196	38416	7529536	14.0000000	5.8087857
197	38809	7645373	14.0356688	5.8186479
198	39204	7762392	14.0712473	5.8284767
199	39601	7880599	14.1067360	5.8382725
200	40000	8000000	14.1421356	5.8480355
201	40401	8120601	14.1774469	5.8577660
202	40804	8242408	14.2126704	5.8674643
203	41209	8365427	14.2478068	5.8771307
204	41616	8489664	14.2828569	5.8867653

SQUARES, CUBES, SQUARE ROOTS, CUBE ROOTS — *Continued*

NUMBER	SQUARE	CUBE	SQUARE ROOT	CUBE ROOT
205	42025	8615125	14.3178211	5.8963685
206	42436	8741816	14.3527001	5.9059406
207	42849	8869743	14.3874946	5.9154817
208	43264	8998912	14.4222051	5.9249921
209	43681	9129329	14.4568323	5.9344721
210	44100	9261000	14.4913767	5.9439220
211	44521	9393931	14.5258390	5.9533418
212	44944	9528128	14.5602198	5.9627320
213	45369	9663597	14.5945195	5.9720926
214	45796	9800344	14.6287388	5.9814240
215	46225	9938375	14.6628783	5.9907264
216	46656	10077696	14.6969385	6.0000000
217	47089	10218313	14.7309199	6.0092450
218	47524	10360232	14.7648231	6.0184617
219	47961	10503459	14.7986486	6.0276502
220	48400	10648000	14.8323970	6.0368107
221	48841	10793861	14.8660687	6.0459435
222	49284	10941048	14.8996644	6.0550489
223	49729	11089567	14.9331845	6.0641270
224	50176	11239424	14.9666295	6.0731779
225	50625	11390625	15.0000000	6.0822020
226	51076	11543176	15.0332964	6.0911994
227	51529	11697083	15.0665192	6.1001702
228	51984	11852352	15.0996689	6.1091147
229	52441	12008989	15.1327460	6.1180332
230	52900	12167000	15.1657509	6.1269257
231	53361	12326391	15.1986842	6.1357924
232	53824	12487168	15.2315462	6.1446337
233	54289	12649337	15.2643375	6.1534495
234	54756	12812904	15.2970585	6.1622401
235	55225	12977875	15.3297097	6.1710058
236	55696	13144256	15.3622915	6.1797466
237	56169	13312053	15.3948043	6.1884628
238	56644	13481272	15.4272486	6.1971544
239	57121	13651919	15.4596248	6.2058218
240	57600	13824000	15.4919334	6.2144650
241	58081	13997521	15.5241747	6.2230843
242	58564	14172488	15.5563492	6.2316797
243	59049	14348907	15.5884573	6.2402515
244	59536	14526784	15.6204994	6.2487998
245	60025	14706125	15.6524758	6.2573248

SQUARES, CUBES, SQUARE ROOTS, CUBE ROOTS—*Continued*

NUMBER	SQUARE	CUBE	SQUARE ROOT	CUBE ROOT
246	60516	14886936	15.6843871	6.2658266
247	61009	15069223	15.7162336	6.2743054
248	61504	15252992	15.7480157	6.2827613
249	62001	15438249	15.7797338	6.2911946
250	62500	15625000	15.8113883	6.2996053
251	63001	15813251	15.8429795	6.3079935
252	63504	16003008	15.8745079	6.3163596
253	64009	16194277	15.9059737	6.3247035
254	64516	16387064	15.9373775	6.3330256
255	65025	16581375	15.9687194	6.3413257
256	65536	16777216	16.0000000	6.3496042
257	66049	16974593	16.0312195	6.3578611
258	66564	17173512	16.0623784	6.3660968
259	67081	17373979	16.0934769	6.3743111
260	67600	17576000	16.1245155	6.3825043
261	68121	17779581	16.1554944	6.3906765
262	68644	17984728	16.1864141	6.3988279
263	69169	18191447	16.2172747	6.4069585
264	69696	18399744	16.2480768	6.4150687
265	70225	18609625	16.2788206	6.4231583
266	70756	18821096	16.3095064	6.4312276
267	71289	19034163	16.3401346	6.4392767
268	71824	19248832	16.3707055	6.4473057
269	72361	19465109	16.4012195	6.4553148
270	72900	19683000	16.4316767	6.4633041
271	73441	19902511	16.4620776	6.4712736
272	73984	20123648	16.4924225	6.4792236
273	74529	20346417	16.5227116	6.4871541
274	75076	20570824	16.5529454	6.4950653
275	75625	20796875	16.5831240	6.5029572
276	76176	21024576	16.6132477	6.5108300
277	76729	21253933	16.6433170	6.5186839
278	77284	21484952	16.6733320	6.5265189
279	77841	21717639	16.7032931	6.5343351
280	78400	21952000	16.7332005	6.5421326
281	78961	22188041	16.7630546	6.5499116
282	79524	22425768	16.7928556	6.5576722
283	80089	22665187	16.8226038	6.5654144
284	80656	22906304	16.8522995	6.5731385
285	81225	23149125	16.8819430	6.5808443
286	81796	23393656	16.9115345	6.5885323

SQUARES, CUBES, SQUARE ROOTS, CUBE ROOTS—*Continued*

NUMBER	SQUARE	CUBE	SQUARE ROOT	CUBE ROOT
287	82369	23639903	16.9410743	6.5962023
288	82944	23887872	16.9705627	6.6038545
289	83521	24137569	17.0000000	6.6114890
290	84100	24389000	17.0293864	6.6191060
291	84681	24642171	17.0587221	6.6267054
292	85264	24897088	17.0880075	6.6342874
293	85849	25153757	17.1172428	6.6418522
294	86436	25412184	17.1464282	6.6493998
295	87025	25672375	17.1755640	6.6569302
296	87616	25934336	17.2046505	6.6644437
297	88209	26198073	17.2336879	6.6719403
298	88804	26463592	17.2626765	6.6794200
299	89401	26730899	17.2916165	6.6868831
300	90000	27000000	17.3205081	6.6943295
301	90601	27270901	17.3493516	6.7017593
302	91204	27543608	17.3781472	6.7091729
303	91809	27818127	17.4068952	6.7165700
304	92416	28094464	17.4355958	6.7239508
305	93025	28372625	17.4642492	6.7313155
306	93636	28652616	17.4928557	6.7386641
307	94249	28934443	17.5214155	6.7459967
308	94864	29218112	17.5499288	6.7533134
309	95481	29503629	17.5783958	6.7606143
310	96100	29791000	17.6068169	6.7678995
311	96721	30080231	17.6351921	6.7751690
312	97344	30371328	17.6635217	6.7824229
313	97969	30664297	17.6918060	6.7896613
314	98596	30959144	17.7200451	6.7968844
315	99225	31255875	17.7482393	6.8040921
316	99856	31554496	17.7763888	6.8112847
317	100489	31855013	17.8044938	6.8184620
318	101124	32157432	17.8325545	6.8256242
319	101761	32461759	17.8605711	6.8327714
320	102400	32768000	17.8885438	6.8399037
321	103041	33076161	17.9164729	6.8470213
322	103684	33386248	17.9443584	6.8541240
323	104329	33698267	17.9722008	6.8612120
324	104976	34012224	18.0000000	6.8682855
325	105625	34328125	18.0277564	6.8753443
326	106276	34645976	18.0554701	6.8823888
327	106929	34965783	18.0831413	6.8894188

SQUARES, CUBES, SQUARE ROOTS, CUBE ROOTS—*Continued*

NUMBER	SQUARE	CUBE	SQUARE ROOT	CUBE ROOT
328	107584	35287552	18.1107703	6.8964345
329	108241	35611289	18.1383571	6.9034359
330	108900	35937000	18.1659021	6.9104232
331	109561	36264691	18.1934054	6.9173964
332	110224	36594368	18.2208672	6.9243556
333	110889	36926037	18.2482876	6.9313008
334	111556	37259704	18.2756669	6.9382321
335	112225	37595375	18.3030052	6.9451496
336	112896	37933056	18.3303028	6.9520533
337	113569	38272753	18.3575598	6.9589434
338	114244	38614472	18.3847763	6.9658198
339	114921	38958219	18.4119526	6.9726826
340	115600	39304000	18.4390889	6.9795321
341	116281	39651821	18.4661853	6.9863681
342	116964	40001688	18.4932420	6.9931906
343	117649	40353607	18.5202592	7.0000000
344	118336	40707584	18.5472370	7.0067962
345	119025	41063625	18.5741756	7.0135791
346	119716	41421736	18.6010752	7.0203490
347	120409	41781923	18.6279360	7.0271058
348	121104	42144192	18.6547581	7.0338497
349	121801	42508549	18.6815417	7.0405806
350	122500	42875000	18.7082869	7.0472987
351	123201	43243551	18.7349940	7.0540041
352	123904	43614208	18.7616630	7.0606967
353	124609	43986977	18.7882942	7.0673767
354	125316	44361864	18.8148877	7.0740440
355	126025	44738875	18.8414437	7.0806988
356	126736	45118016	18.8679623	7.0873411
357	127449	45499293	18.8944436	7.0939709
358	128164	45882712	18.9208879	7.1005885
359	128881	46268279	18.9472953	7.1071937
360	129600	46656000	18.9736660	7.1137866
361	130321	47045881	19.0000000	7.1203674
362	131044	47437928	19.0262976	7.1269360
363	131769	47832147	19.0525589	7.1334925
364	132496	48228544	19.0787840	7.1400370
365	133225	48627125	19.1049732	7.1465695
366	133956	49027896	19.1311265	7.1530901
367	134689	49430863	19.1572441	7.1595988
368	135424	49836032	19.1833261	7.1660957

SQUARES, CUBES, SQUARE ROOTS, CUBE ROOTS — *Continued*

NUMBER	SQUARE	CUBE	SQUARE ROOT	CUBE ROOT
369	136161	50243409	19.2093727	7.1725809
370	136900	50653000	19.2353841	7.1790544
371	137641	51064811	19.2613603	7.1855162
372	138384	51478848	19.2873015	7.1919663
373	139129	51895117	19.3132079	7.1984050
374	139876	52313624	19.3390796	7.2048322
375	140625	52734375	19.3649167	7.2112479
376	141376	53157376	19.3907194	7.2176522
377	142129	53582633	19.4164878	7.2240450
378	142884	54010152	19.4422221	7.2304268
379	143641	54439939	19.4679223	7.2367972
380	144400	54872000	19.4935887	7.2431565
381	145161	55306341	19.5192213	7.2495045
382	145924	55742968	19.5448203	7.2558415
383	146689	56181887	19.5703858	7.2621675
384	147456	56623104	19.5959179	7.2684824
385	148225	57066625	19.6214169	7.2747864
386	148996	57512456	19.6468827	7.2810794
387	149769	57960603	19.6723156	7.2873617
388	150544	58411072	19.6977156	7.2936330
389	151321	58863869	19.7230829	7.2998936
390	152100	59319000	19.7484177	7.3061436
391	152881	59776471	19.7737199	7.3123828
392	153664	60236288	19.7989899	7.3186114
393	154449	60698457	19.8242276	7.3248295
394	155236	61162984	19.8494332	7.3310369
395	156025	61629875	19.8746069	7.3372339
396	156816	62099136	19.8997487	7.3434205
397	157609	62570773	19.9248588	7.3495966
398	158404	63044792	19.9499373	7.3557624
399	159201	63521199	19.9749844	7.3619178
400	160000	64000000	20.0000000	7.3680630
401	160801	64481201	20.0249844	7.3741979
402	161604	64964808	20.0499377	7.3803227
403	162409	65450827	20.0748599	7.3864373
404	163216	65939264	20.0997512	7.3925418
405	164025	66430125	20.1246118	7.3986363
406	164836	66923416	20.1494417	7.4047206
407	165649	67419143	20.1742410	7.4107950
408	166464	67917312	20.1990099	7.4168595
409	167281	68417929	20.2237484	7.4229142

SQUARES, CUBES, SQUARE ROOTS, CUBE ROOTS—*Continued*

NUMBER	SQUARE	CUBE	SQUARE ROOT	CUBE ROOT
410	168100	68921000	20.2484567	7.4289589
411	168921	69426531	20.2731349	7.4349938
412	169744	69934528	20.2977831	7.4410189
413	170569	70444997	20.3224014	7.4470342
414	171396	70957944	20.3469899	7.4530399
415	172225	71473375	20.3715488	7.4590359
416	173056	71991296	20.3960781	7.4650223
417	173889	72511713	20.4205779	7.4709991
418	174724	73034632	20.4450483	7.4769664
419	175561	73560059	20.4694895	7.4829242
420	176400	74088000	20.4939015	7.4888724
421	177241	74618461	20.5182845	7.4948113
422	178084	75151448	20.5426386	7.5007406
423	178929	75686967	20.5669638	7.5066607
424	179776	76225024	20.5912603	7.5125715
425	180625	76765625	20.6155281	7.5184730
426	181476	77308776	20.6397674	7.5243652
427	182329	77854483	20.6639783	7.5302482
428	183184	78402752	20.6881609	7.5361221
429	184041	78953589	20.7123152	7.5419867
430	184900	79507000	20.7364414	7.5478423
431	185761	80062991	20.7605395	7.5536888
432	186624	80621568	20.7846097	7.5595263
433	187489	81182737	20.8086520	7.5653548
434	188356	81746504	20.8326667	7.5711743
435	189225	82312875	20.8566536	7.5769849
436	190096	82881856	20.8806130	7.5827865
437	190969	83453453	20.9045450	7.5885793
438	191844	84027672	20.9284495	7.5943633
439	192721	84604519	20.9523268	7.6001385
440	193600	85184000	20.9761770	7.6059049
441	194481	85766121	21.0000000	7.6116626
442	195364	86350888	21.0237960	7.6174116
443	196249	86938307	21.0475652	7.6231519
444	197136	87528384	21.0713075	7.6288837
445	198025	88121125	21.0950231	7.6346067
446	198916	88716536	21.1187121	7.6403213
447	199809	89314623	21.1423745	7.6460272
448	200704	89915392	21.1660105	7.6517247
449	201601	90518849	21.1896201	7.6574138
450	202500	91125000	21.2132034	7.6630943

SQUARES, CUBES, SQUARE ROOTS, CUBE ROOTS — *Continued*

NUMBER	SQUARE	CUBE	SQUARE ROOT	CUBE ROOT
451	203401	91733851	21.2367606	7.6687665
452	204304	92345408	21.2602916	7.6744303
453	205209	92959677	21.2837967	7.6800857
454	206116	93576664	21.3072758	7.6857328
455	207025	94196375	21.3307290	7.6913717
456	207936	94818816	21.3541565	7.6970023
457	208849	95443993	21.3775583	7.7026246
458	209764	96071912	21.4009346	7.7082388
459	210681	96702579	21.4242853	7.7138448
460	211600	97336000	21.4476106	7.7194426
461	212521	97972181	21.4709106	7.7250325
462	213444	98611128	21.4941853	7.7306141
463	214369	99252847	21.5174348	7.7361877
464	215296	99897344	21.5406592	7.7417532
465	216225	100544625	21.5638587	7.7473109
466	217156	101194696	21.5870331	7.7528606
467	218089	101847563	21.6101828	7.7584023
468	219024	102503232	21.6333077	7.7639361
469	219961	103161709	21.6564078	7.7694620
470	220900	103823000	21.6794834	7.7749801
471	221841	104487111	21.7025344	7.7804904
472	222784	105154048	21.7255610	7.7859928
473	223729	105823817	21.7485632	7.7914875
474	224676	106496424	21.7715411	7.7969745
475	225625	107171875	21.7944947	7.8024538
476	226576	107850176	21.8174242	7.8079254
477	227529	108531333	21.8403297	7.8133892
478	228484	109215352	21.8632111	7.8188456
479	229441	109902239	21.8860686	7.8242942
480	230400	110592000	21.9089023	7.8297353
481	231361	111284641	21.9317122	7.8351688
482	232324	111980168	21.9544984	7.8405949
483	233289	112678587	21.9772610	7.8460134
484	234256	113379904	22.0000000	7.8514244
485	235225	114084125	22.0227155	7.8568281
486	236196	114791256	22.0454077	7.8622242
487	237169	115501303	22.0680765	7.8676130
488	238144	116214272	22.0907220	7.8729944
489	239121	116930169	22.1133444	7.8783684
490	240100	117649000	22.1359436	7.8837352
491	241081	118370771	22.1585198	7.8890946

SQUARES, CUBES, SQUARE ROOTS, CUBE ROOTS—*Continued*

NUMBER	SQUARE	CUBE	SQUARE ROOT	CUBE ROOT
492	242064	119095488	22.1810730	7.8944468
493	243049	119823157	22.2036033	7.8997917
494	244036	120553784	22.2261108	7.9051294
495	245025	121287375	22.2485955	7.9104599
496	246016	122023936	22.2710575	7.9157832
497	247009	122763473	22.2934968	7.9210994
498	248004	123505992	22.3159136	7.9264085
499	249001	124251499	22.3383079	7.9317104
500	250000	125000000	22.3606798	7.9370053
501	251001	125751501	22.3830293	7.9422931
502	252004	126506008	22.4053365	7.9475739
503	253009	127263527	22.4276615	7.9528477
504	254016	128024064	22.4499443	7.9581144
505	255025	128787625	22.4722051	7.9633743
506	256036	129554216	22.4944438	7.9686271
507	257049	130323843	22.5166605	7.9738731
508	258064	131096512	22.5388553	7.9791122
509	259081	131872229	22.5610283	7.9843444
510	260100	132651000	22.5831796	7.9895697
511	261121	133432831	22.6053091	7.9947883
512	262144	134217728	22.6274170	8.0000000
513	263169	135005697	22.6495033	8.0052049
514	264196	135796744	22.6715681	8.0104032
515	265225	136590875	22.6936114	8.0155946
516	266256	137388096	22.7156334	8.0207794
517	267289	138188413	22.7376340	8.0259574
518	268324	138991832	22.7596134	8.0311287
519	269361	139798359	22.7815715	8.0362935
520	270400	140608000	22.8035085	8.0414515
521	271441	141420761	22.8254244	8.0466030
522	272484	142236648	22.8473193	8.0517479
523	273529	143055667	22.8691933	8.0568862
524	274576	143877824	22.8910463	8.0620180
525	275625	144703125	22.9128785	8.0671432
526	276676	145531576	22.9346899	8.0722620
527	277729	146363183	22.9564806	8.0773743
528	278784	147197952	22.9782506	8.0824800
529	279841	148035889	23.0000000	8.0875794
530	280900	148877000	23.0217289	8.0926723
531	281961	149721291	23.0434372	8.0977589
532	283024	150568768	23.0651252	8.1028390

SQUARES, CUBES, SQUARE ROOTS, CUBE ROOTS — *Continued*

NUMBER	SQUARE	CUBE	SQUARE ROOT	CUBE ROOT
533	284089	151419437	23.0867928	8.1079128
534	285156	152273304	23.1084400	8.1129803
535	286225	153130375	23.1300670	8.1180414
536	287296	153990656	23.1516738	8.1230962
537	288369	154854153	23.1732605	8.1281447
538	289444	155720872	23.1948270	8.1331870
539	290521	156590819	23.2163735	8.1382230
540	291600	157464000	23.2379001	8.1432529
541	292681	158340421	23.2594067	8.1482765
542	293764	159220088	23.2808935	8.1532939
543	294849	160103007	23.3023604	8.1583051
544	295936	160989184	23.3238076	8.1633102
545	297025	161878625	23.3452351	8.1683092
546	298116	162771336	23.3666429	8.1733020
547	299209	163667323	23.3880311	8.1782888
548	300304	164566592	23.4093998	8.1832695
549	301401	165469149	23.4307490	8.1882441
550	302500	166375000	23.4520788	8.1932127
551	303601	167284151	23.4733892	8.1981753
552	304704	168196608	23.4946802	8.2031319
553	305809	169112377	23.5159520	8.2080825
554	306916	170031464	23.5372046	8.2130271
555	308025	170953875	23.5584380	8.2179657
556	309136	171879616	23.5796522	8.2228985
557	310249	172808693	23.6008474	8.2278254
558	311364	173741112	23.6220236	8.2327463
559	312481	174676879	23.6431808	8.2376614
560	313600	175616000	23.6643191	8.2425706
561	314721	176558481	23.6854386	8.2474740
562	315844	177504328	23.7065392	8.2523715
563	316969	178453547	23.7276210	8.2572633
564	318096	179406144	23.7486842	8.2621492
565	319225	180362125	23.7697286	8.2670294
566	320356	181321496	23.7907545	8.2719039
567	321489	182284263	23.8117618	8.2767726
568	322624	183250432	23.8327506	8.2816355
569	323761	184220009	23.8537209	8.2864928
570	324900	185193000	23.8746728	8.2913444
571	326041	186169411	23.8956063	8.2961903
572	327184	187149248	23.9165215	8.3010304
573	328329	188132517	23.9374184	8.3058651

SQUARES, CUBES, SQUARE ROOTS, CUBE ROOTS — *Continued*

NUMBER	SQUARE	CUBE	SQUARE ROOT	CUBE ROOT
574	329476	189119224	23.9582971	8.3106941
575	330625	190109375	23.9791576	8.3155175
576	331776	191102976	24.0000000	8.3203353
577	332929	192100033	24.0208243	8.3251475
578	334084	193100552	24.0416306	8.3299542
579	335241	194104539	24.0624188	8.3347553
580	336400	195112000	24.0831891	8.3395509
581	337561	196122941	24.1039416	8.3443410
582	338724	197137368	24.1246762	8.3491256
583	339889	198155287	24.1453929	8.3539047
584	341056	199176704	24.1660919	8.3586784
585	342225	200201625	24.1867732	8.3634466
586	343396	201230056	24.2074369	8.3682095
587	344569	202262003	24.2280829	8.3729668
588	345744	203297472	24.2487113	8.3777188
589	346921	204336469	24.2693222	8.3824653
590	348100	205379000	24.2899156	8.3872065
591	349281	206425071	24.3104916	8.3919423
592	350464	207474688	24.3310501	8.3966729
593	351649	208527857	24.3515913	8.4013981
594	352836	209584584	24.3721152	8.4061180
595	354025	210644875	24.3926218	8.4108326
596	355216	211708736	24.4131112	8.4155419
597	356409	212776173	24.4335834	8.4202460
598	357604	213847192	24.4540385	8.4249448
599	358801	214921799	24.4744765	8.4296383
600	360000	216000000	24.4948974	8.4343267
601	361201	217081801	24.5153013	8.4390098
602	362404	218167208	24.5356883	8.4436877
603	363609	219256227	24.5560583	8.4483605
604	364816	220348864	24.5764115	8.4530281
605	366025	221445125	24.5967478	8.4576906
606	367236	222545016	24.6170673	8.4623479
607	368449	223648543	24.6373700	8.4670001
608	369664	224755712	24.6576560	8.4716471
609	370881	225866529	24.6779254	8.4762892
610	372100	226981000	24.6981781	8.4809261
611	373321	228099131	24.7184142	8.4855579
612	374544	229220928	24.7386338	8.4901848
613	375769	230346397	24.7588368	8.4948065
614	376996	231475544	24.7790234	8.4994233

SQUARES, CUBES, SQUARE ROOTS, CUBE ROOTS—*Continued*

NUMBER	SQUARE	CUBE	SQUARE ROOT	CUBE ROOT
615	378225	232608375	24.7991935	8.5040350
616	379456	233744896	24.8193473	8.5086417
617	380689	234885113	24.8394847	8.5132435
618	381924	236029032	24.8596058	8.5178403
619	383161	237176659	24.8797106	8.5224321
620	384400	238328000	24.8997992	8.5270189
621	385641	239483061	24.9198716	8.5316009
622	386884	240641848	24.9399278	8.5361780
623	388129	241804367	24.9599679	8.5407501
624	389376	242970624	24.9799920	8.5453173
625	390625	244140625	25.0000000	8.5498797
626	391876	245314376	25.0199920	8.5544372
627	393129	246491883	25.0399681	8.5589899
628	394384	247673152	25.0599282	8.5635377
629	395641	248858189	25.0798724	8.5680807
630	396900	250047000	25.0998008	8.5726189
631	398161	251239591	25.1197134	8.5771523
632	399424	252435968	25.1396102	8.5816809
633	400689	253636137	25.1594913	8.5862047
634	401956	254840104	25.1793566	8.5907238
635	403225	256047875	25.1992063	8.5952380
636	404496	257259456	25.2190404	8.5997476
637	405769	258474853	25.2388589	8.6042525
638	407044	259694072	25.2586619	8.6087526
639	408321	260917119	25.2784493	8.6132480
640	409600	262144000	25.2982213	8.6177388
641	410881	263374721	25.3179778	8.6222248
642	412164	264609288	25.3377189	8.6267063
643	413449	265847707	25.3574447	8.6311830
644	414736	267089984	25.3771551	8.6356551
645	416025	268336125	25.3968502	8.6401226
646	417316	269586136	25.4165301	8.6445855
647	418609	270840023	25.4361947	8.6490437
648	419904	272097792	25.4558441	8.6534974
649	421201	273359449	25.4754784	8.6579465
650	422500	274625000	25.4950976	8.6623911
651	423801	275894451	25.5147016	8.6668310
652	425104	277167808	25.5342907	8.6712665
653	426409	278445077	25.5538647	8.6756974
654	427716	279726264	25.5734237	8.6801237
655	429025	281011375	25.5929678	8.6845456

SQUARES, CUBES, SQUARE ROOTS, CUBE ROOTS — *Continued*

NUMBER	SQUARE	CUBE	SQUARE ROOT	CUBE ROOT
656	430336	282300416	25.6124969	8.6889630
657	431649	283593393	25.6320112	8.6933759
658	432964	284890312	25.6515107	8.6977843
659	434281	286191179	25.6709953	8.7021882
660	435600	287496000	25.6904652	8.7065877
661	436921	288804781	25.7099203	8.7109827
662	438244	290117528	25.7293607	8.7153734
663	439569	291434247	25.7487864	8.7197596
664	440896	292754944	25.7681975	8.7241414
665	442225	294079625	25.7875939	8.7285187
666	443556	295408296	25.8069758	8.7328918
667	444889	296740963	25.8263431	8.7372604
668	446224	298077632	25.8456960	8.7416246
669	447561	299418309	25.8650343	8.7459846
670	448900	300763000	25.8843582	8.7503401
671	450241	302111711	25.9036677	8.7546913
672	451584	303464448	25.9229628	8.7590383
673	452929	304821217	25.9422435	8.7633809
674	454276	306182024	25.9615100	8.7677192
675	455625	307546875	25.9807621	8.7720532
676	456976	308915776	26.0000000	8.7763830
677	458329	310288733	26.0192237	8.7807084
678	459684	311665752	26.0384331	8.7850296
679	461041	313046839	26.0576284	8.7893466
680	462400	314432000	26.0768096	8.7936593
681	463761	315821241	26.0959767	8.7979679
682	465124	317214568	26.1151297	8.8022721
683	466489	318611987	26.1342687	8.8065722
684	467856	320013501	26.1533937	8.8108681
685	469225	321419125	26.1725047	8.8151598
686	470596	322828856	26.1916017	8.8194474
687	471969	324242703	26.2106848	8.8237307
688	473344	325660672	26.2297541	8.8280099
689	474721	327082769	26.2488095	8.8322850
690	476100	328509000	26.2678511	8.8365559
691	477481	329939371	26.2868789	8.8408227
692	478864	331373888	26.3058929	8.8450854
693	480249	332812557	26.3248932	8.8493440
694	481636	334255384	26.3438797	8.8535985
695	483025	335702375	26.3628527	8.8578489
696	484416	337153536	26.3818119	8.8620952

SQUARES, CUBES, SQUARE ROOTS, CUBE ROOTS—*Continued*

NUMBER	SQUARE	CUBE	SQUARE ROOT	CUBE ROOT
697	485809	338608873	26.4007576	8.8663375
698	487204	340068392	26.4196896	8.8705757
699	488601	341532099	26.4386081	8.8748099
700	490000	343000000	26.4575131	8.8790400
701	491401	344472101	26.4764046	8.8832661
702	492804	345948408	26.4952826	8.8874882
703	494209	347428927	26.5141472	8.8917063
704	495616	348913664	26.5329983	8.8959204
705	497025	350402625	26.5518361	8.9001304
706	498436	351895816	26.5706605	8.9043366
707	499849	353393243	26.5894716	8.9085387
708	501264	354894912	26.6082694	8.9127369
709	502681	356400829	26.6270539	8.9169311
710	504100	357911000	26.6458252	8.9211214
711	505521	359425431	26.6645833	8.9253078
712	506944	360944128	26.6833281	8.9294902
713	508369	362467097	26.7020598	8.9336687
714	509796	363994344	26.7207784	8.9378433
715	511225	365525875	26.7394839	8.9420140
716	512656	367061696	26.7581763	8.9461809
717	514089	368601813	26.7768557	8.9503438
718	515524	370146232	26.7955220	8.9545029
719	516961	371694959	26.8141754	8.9586581
720	518400	373248000	26.8328157	8.9628095
721	519841	374805361	26.8514432	8.9669570
722	521284	376367048	26.8700577	8.9711007
723	522729	377933067	26.8886593	8.9752406
724	524176	379503424	26.9072481	8.9793766
725	525625	381078125	26.9258240	8.9835089
726	527076	382657176	26.9443872	8.9876373
727	528529	384240583	26.9629375	8.9917620
728	529984	385828352	26.9814751	8.9958829
729	531441	387420489	27.0000000	9.0000000
730	532900	389017000	27.0185122	9.0041134
731	534361	390617891	27.0370117	9.0082229
732	535824	392223168	27.0554985	9.0123288
733	537289	393832837	27.0739727	9.0164309
734	538756	395446904	27.0924344	9.0205293
735	540225	397065375	27.1108834	9.0246239
736	541696	398688256	27.1293199	9.0287149
737	543169	400315553	27.1477439	9.0328021

SQUARES, CUBES, SQUARE ROOTS, CUBE ROOTS—*Continued*

NUMBER	SQUARE	CUBE	SQUARE ROOT	CUBE ROOT
738	544644	401947272	27.1661554	9.0368857
739	546121	403583419	27.1845544	9.0409655
740	547600	405224000	27.2029410	9.0450417
741	549081	406869021	27.2213152	9.0491142
742	550564	408518488	27.2396769	9.0531831
743	552049	410172407	27.2580263	9.0572482
744	553536	411830784	27.2763634	9.0613098
745	555025	413493625	27.2946881	9.0653677
746	556516	415160936	27.3130006	9.0694220
747	558009	416832723	27.3313007	9.0734726
748	559504	418508992	27.3495887	9.0775197
749	561001	420189749	27.3678644	9.0815631
750	562500	421875000	27.3861279	9.0856030
751	564001	423564751	27.4043792	9.0896392
752	565504	425259008	27.4226184	9.0936719
753	567009	426957777	27.4408455	9.0977010
754	568516	428661064	27.4590604	9.1017265
755	570025	430368875	27.4772633	9.1057485
756	571536	432081216	27.4954542	9.1097669
757	573049	433798093	27.5136330	9.1137818
758	574564	435519512	27.5317998	9.1177931
759	576081	437245479	27.5499546	9.1218010
760	577600	438976000	27.5680975	9.1258053
761	579121	440711081	27.5862284	9.1298061
762	580644	442450728	27.6043475	9.1338034
763	582169	444194947	27.6224546	9.1377971
764	583696	445943744	27.6405499	9.1417874
765	585225	447697125	27.6586334	9.1457742
766	586756	449455096	27.6767050	9.1497576
767	588289	451217663	27.6947648	9.1537375
768	589824	452984832	27.7128129	9.1577139
769	591361	454756609	27.7308492	9.1616869
770	592900	456533000	27.7488739	9.1656565
771	594441	458314011	27.7668868	9.1696225
772	595984	460099648	27.7848880	9.1735852
773	597529	461889917	27.8028775	9.1775445
774	599076	463684824	27.8208555	9.1815003
775	600625	465484375	27.8388218	9.1854527
776	602176	467288576	27.8567766	9.1894018
777	603729	469097433	27.8747197	9.1933474
778	605284	470910952	27.8926514	9.1972897

SQUARES, CUBES, SQUARE ROOTS, CUBE ROOTS — *Continued*

NUMBER	SQUARE	CUBE	SQUARE ROOT	CUBE ROOT
779	606841	472729139	27.9105715	9.2012286
780	608400	474552000	27.9284801	9.2051641
781	609961	476379541	27.9463772	9.2090962
782	611524	478211768	27.9642629	9.2130250
783	613089	480048687	27.9821372	9.2169505
784	614656	481890304	28.0000000	9.2208726
785	616225	483736625	28.0178515	9.2247914
786	617796	485587656	28.0356915	9.2287068
787	619369	487443403	28.0535203	9.2326189
788	620944	489303872	28.0713377	9.2365277
789	622521	491169069	28.0891438	9.2404333
790	624100	493039000	28.1069386	9.2443355
791	625681	494913671	28.1247222	9.2482344
792	627264	496793088	28.1424946	9.2521300
793	628849	498677257	28.1602557	9.2560224
794	630436	500566184	28.1780056	9.2599114
795	632025	502459875	28.1957444	9.2637973
796	633616	504358336	28.2134720	9.2676798
797	635209	506261573	28.2311884	9.2715592
798	636804	508169592	28.2488938	9.2754352
799	638401	510082399	28.2665881	9.2793081
800	640000	512000000	28.2842712	9.2831777
801	641601	513922401	28.3019434	9.2870440
802	643204	515849608	28.3196045	9.2909072
803	644809	517781627	28.3372546	9.2947671
804	646416	519718464	28.3548938	9.2986239
805	648025	521660125	28.3725219	9.3024775
806	649636	523606616	28.3901391	9.3063278
807	651249	525557943	28.4077454	9.3101750
808	652864	527514112	28.4253408	9.3140190
809	654481	529475129	28.4429253	9.3178599
810	656100	531441000	28.4604989	9.3216975
811	657721	533411731	28.4780617	9.3255320
812	659344	535387328	28.4956137	9.3293634
813	660969	537367797	28.5131549	9.3331916
814	662596	539353144	28.5306852	9.3370167
815	664225	541343375	28.5482048	9.3408386
816	665856	543338496	28.5657137	9.3446575
817	667489	545338513	28.5832119	9.3484731
818	669124	547343432	28.6006993	9.3522857
819	670761	549353259	28.6181760	9.3560952

SQUARES, CUBES, SQUARE ROOTS, CUBE ROOTS—*Continued*

NUMBER	SQUARE	CUBE	SQUARE ROOT	CUBE ROOT
820	672400	551368000	28.6356421	9.3599016
821	674041	553387661	28.6530976	9.3637049
822	675684	555412248	28.6705424	9.3675051
823	677329	557441767	28.6879766	9.3713022
824	678976	559476224	28.7054002	9.3750963
825	680625	561515625	28.7228132	9.3788873
826	682276	563559976	28.7402157	9.3826752
827	683929	565609283	28.7576077	9.3864600
828	685584	567663552	28.7749891	9.3902419
829	687241	569722789	28.7923601	9.3940206
830	688900	571787000	28.8097206	9.3977964
831	690561	573856191	28.8270706	9.4015691
832	692224	575930368	28.8444102	9.4053387
833	693889	578009537	28.8617394	9.4091054
834	695556	580093704	28.8790582	9.4128690
835	697225	582182875	28.8963666	9.4166297
836	698896	584277056	28.9136646	9.4203873
837	700569	586376253	28.9309523	9.4241420
838	702244	588480472	28.9482297	9.4278936
839	703921	590589719	28.9654967	9.4316423
840	705600	592704000	28.9827535	9.4353880
841	707281	594823321	29.0000000	9.4391307
842	708964	596947688	29.0172363	9.4428704
843	710649	599077107	29.0344623	9.4466072
844	712336	601211584	29.0516781	9.4503410
845	714025	603351125	29.0688837	9.4540719
846	715716	605495736	29.0860791	9.4577999
847	717409	607645423	29.1032644	9.4615249
848	719104	609800192	29.1204396	9.4652470
849	720801	611960049	29.1376046	9.4689661
850	722500	614125000	29.1547595	9.4726824
851	724201	616295051	29.1719043	9.4763957
852	725904	618470208	29.1890390	9.4801061
853	727609	620650477	29.2061637	9.4838136
854	729316	622835864	29.2232784	9.4875182
855	731025	625026375	29.2403830	9.4912200
856	732736	627222016	29.2574777	9.4949188
857	734449	629422793	29.2745623	9.4986147
858	736164	631628712	29.2916370	9.5023078
859	737881	633839779	29.3087018	9.5059980
860	739600	636056000	29.3257566	9.5096854

SQUARES, CUBES, SQUARE ROOTS, CUBE ROOTS — *Continued*

NUMBER	SQUARE	CUBE	SQUARE ROOT	CUBE ROOT
861	741321	638277381	29.3428015	9.5133699
862	743044	640503928	29.3598365	9.5170515
863	744769	642735647	29.3768616	9.5207303
864	746496	644972544	29.3938769	9.5244063
865	748225	647214625	29.4108823	9.5280794
866	749956	649461896	29.4278779	9.5317497
867	751689	651714363	29.4448637	9.5354172
868	753424	653972032	29.4618397	9.5390818
869	755161	656234909	29.4788059	9.5427437
870	756900	658503000	29.4957624	9.5464027
871	758641	660776311	29.5127091	9.5500589
872	760384	663054848	29.5296461	9.5537123
873	762129	665338617	29.5465734	9.5573630
874	763876	667627624	29.5634910	9.5610108
875	765625	669921875	29.5803989	9.5646559
876	767376	672221376	29.5972972	9.5682982
877	769129	674526133	29.6141858	9.5719377
878	770884	676836152	29.6310648	9.5755745
879	772641	679151439	29.6479342	9.5792085
880	774400	681472000	29.6647939	9.5828397
881	776161	683797841	29.6816442	9.5864682
882	777924	686128968	29.6984848	9.5900939
883	779689	688465387	29.7153159	9.5937169
884	781456	690807104	29.7321375	9.5973373
885	783225	693154125	29.7489496	9.6009548
886	784996	695506456	29.7657521	9.6045696
887	786769	697864103	29.7825452	9.6081817
888	788544	700227072	29.7993289	9.6117911
889	790321	702595369	29.8161030	9.6153977
890	792100	704969000	29.8328678	9.6190017
891	793881	707347971	29.8496231	9.6226030
892	795664	709732288	29.8663690	9.6262016
893	797449	712121957	29.8831056	9.6297975
894	799236	714516984	29.8998328	9.6333907
895	801025	716917375	29.9165506	9.6369812
896	802816	719323136	29.9332591	9.6405690
897	804609	721734273	29.9499583	9.6441542
898	806404	724150792	29.9666481	9.6477367
899	808201	726572699	29.9833287	9.6513166
900	810000	729000000	30.0000000	9.6548938
901	811801	731432701	30.0166620	9.6584684

SQUARES, CUBES, SQUARE ROOTS, CUBE ROOTS — *Continued*

NUMBER	SQUARE	CUBE	SQUARE ROOT	CUBE ROOT
902	813604	733870808	30.0333148	9.6620403
903	815409	736314327	30.0499584	9.6656096
904	817216	738763264	30.0665928	9.6691762
905	819025	741217625	30.0832179	9.6727403
906	820836	743677416	30.0998339	9.6763017
907	822649	746142643	30.1164407	9.6798604
908	824464	748613312	30.1330383	9.6834166
909	826281	751089429	30.1496269	9.6869701
910	828100	753571000	30.1662063	9.6905211
911	829921	756058031	30.1827765	9.6940694
912	831744	758550528	30.1993377	9.6976151
913	833569	761048497	30.2158899	9.7011583
914	835396	763551944	30.2324329	9.7046989
915	837225	766060875	30.2489669	9.7082369
916	839056	768575296	30.2654919	9.7117723
917	840889	771095213	30.2820079	9.7153051
918	842724	773620632	30.2985148	9.7188354
919	844561	776151559	30.3150128	9.7223631
920	846400	778688000	30.3315018	9.7258883
921	848241	781229961	30.3479818	9.7294109
922	850084	783777448	30.3644529	9.7329309
923	851929	786330467	30.3809151	9.7364484
924	853776	788889024	30.3973683	9.7399634
925	855625	791453125	30.4138127	9.7434758
926	857476	794022776	30.4302481	9.7469857
927	859329	796597983	30.4466747	9.7504930
928	861184	799178752	30.4630924	9.7539979
929	863041	801765089	30.4795013	9.7575002
930	864900	804357000	30.4959014	9.7610001
931	866761	806954491	30.5122926	9.7644974
932	868624	809557568	30.5286750	9.7679922
933	870489	812166237	30.5450487	9.7714845
934	872356	814780504	30.5614136	9.7749743
935	874225	817400375	30.5777697	9.7784616
936	876096	820025856	30.5941171	9.7819466
937	877969	822656953	30.6104557	9.7854288
938	879844	825293672	30.6267857	9.7889087
939	881721	827936019	30.6431069	9.7923861
940	883600	830584000	30.6594194	9.7958611
941	885481	833237621	30.6757233	9.7993336
942	887364	835896888	30.6920185	9.8028036

SQUARES, CUBES, SQUARE ROOTS, CUBE ROOTS—*Continued*

NUMBER	SQUARE	CUBE	SQUARE ROOT	CUBE ROOT
943	889249	838561807	30.7083051	9.8062711
944	891136	841232384	30.7245830	9.8097362
945	893025	843908625	30.7408523	9.8131989
946	894916	846590536	30.7571130	9.8166591
947	896809	849278133	30.7733651	9.8201169
948	898704	851971392	30.7896086	9.8235723
949	900601	854670349	30.8058436	9.8270252
950	902500	857375000	30.8220700	9.8304757
951	904401	860085351	30.8382879	9.8339238
952	906304	862801408	30.8544972	9.8373695
953	908209	865523177	30.8706981	9.8408127
954	910116	868250664	30.8868904	9.8442536
955	912025	870983875	30.9030743	9.8476920
956	913936	873722816	30.9192497	9.8511280
957	915849	876467493	30.9354166	9.8545617
958	917764	879217912	30.9515751	9.8579929
959	919681	881974079	30.9677251	9.8614218
960	921600	884736000	30.9838668	9.8648483
961	923521	887503681	31.0000000	9.8682724
962	925444	890277128	31.0161248	9.8716941
963	927369	893056347	31.0322413	9.8751135
964	929296	895841344	31.0483494	9.8785305
965	931225	898632125	31.0644491	9.8819451
966	933156	901428696	31.0805405	9.8853574
967	935089	904231063	31.0966236	9.8887673
968	937024	907039232	31.1126984	9.8921749
969	938961	909853209	31.1287648	9.8955801
970	940900	912673000	31.1448230	9.8989830
971	942841	915498611	31.1608729	9.9023835
972	944784	918330048	31.1769145	9.9057817
973	946729	921167317	31.1929479	9.9091776
974	948676	924010424	31.2089731	9.9125712
975	950625	926859375	31.2249900	9.9159624
976	952576	929714176	31.2409987	9.9193513
977	954529	932574833	31.2569992	9.9227379
978	956484	935441352	31.2729915	9.9261222
979	958441	938313739	31.2889757	9.9295042
980	960400	941192000	31.3049517	9.9328839
981	962361	944076141	31.3209195	9.9362613
982	964324	946966168	31.3368792	9.9396363
983	966289	949862087	31.3528308	9.9430092

SQUARES, CUBES, SQUARE ROOTS, CUBE ROOTS — *Concluded*

NUMBER	SQUARE	CUBE	SQUARE ROOT	CUBE ROOT
984	968256	952763904	31.3687743	9.9463797
985	970225	955671625	31.3847097	9.9497479
986	972196	958585256	31.4006369	9.9531138
987	974169	961504803	31.4165561	9.9564775
988	976144	964430272	31.4324673	9.9598389
989	978121	967361669	31.4483704	9.9631981
990	980100	970299000	31.4642654	9.9665549
991	982081	973242271	31.4801525	9.9699095
992	984064	976191488	31.4960315	9.9732619
993	986049	979146657	31.5119025	9.9766120
994	988036	982107784	31.5277655	9.9799599
995	990025	985074875	31.5436206	9.9833055
996	992016	988047936	31.5594677	9.9866488
997	994009	991026973	31.5753068	9.9899900
998	996004	994011992	31.5911380	9.9933289
999	998001	997002999	31.6069613	9.9966656
1000	1000000	1000000000	31.6227766	10.0000000

WEIGHTS AND MEASURES

TABLE 21

AVOIRDUPOIS WEIGHT

United States and British

GRAINS	DRAMS	OUNCES	POUNDS	HUNDRED-WEIGHTS	GROSS TONS
1.	.03657	.002286	.000143	.00000128	.000000176
27.34375	1.	.0625	.003906	.00003488	.000001744
437.5	16.	1.	.0625	.00055804	.00002790
7000.	256.	16.	1.	.0089286	.0004464
784000.	28672.	1792.	112.	1.	.05
5680000.	573440.	35840.	2240.	20.	1.

1 pound avoirdupois = 1.215278 pounds troy.

1 net ton = 2000 pounds = .892857 gross ton.

INSIDE FINISHING

TABLE 22
 APOTHECARIES' WEIGHT
United States and British

GRAINS	SCRUPLES	DRAMS	OUNCES	POUNDS
1	.05	.016667	.0020833	.000173611
20	1.	.333333	.0416667	.0034722
60	3.	1.	.125	.0104167
480	24.	8.	1.	.0833333
5760	288.	96.	12.	1.

The pound, ounce, and grain are the same as in troy weights.
 The avoirdupois grain = troy grain = apothecaries' grain.

TABLE 23
 TROY WEIGHT
United States and British

GRAINS	PENNYWEIGHTS	OUNCES	POUNDS
1	.041667	.0020833	.0001736
24	1.	.05	.0041667
480	20.	1.	.0833333
5760	240.	12.	1.

1 pound troy = .822857 pound avoirdupois.
 175 ounces troy = 192 ounces avoirdupois.

TABLE 24
 LINEAR MEASURE
United States and British

INCHES	FEET	YARDS	RODS	FURLONGS	MILES
1	.08333	.02778	.0050505	.00012626	.00001578
12	1.	.33333	.0606061	.00151515	.00018939
36	3.	1.	.1818182	.00454545	.00056818
198	16.5	5.5	1.	.025	.003125
7920	660.	220.	40.	1.	.125
63360	5280.	1760.	320.	8.	1.

TABLE 25
 SQUARE OR LAND MEASURE
United States and British

SQUARE INCHES	SQUARE FEET	SQUARE YARDS	SQUARE RODS	ACRES	SQUARE MILES
1	.006944	.000771			
144	1.	.111111			
1296	9.0	1.	.03306	.0002066	
39204	272.25	30.25	1.	.00625	.00000977
6272640	43560.	4840.	160.	1.	.0015625
	27878400.	3097600.	102400.	640.	1.

1 square rod = 40 square rods. 1 acre = 4 square rods.
 1 square acre = 208.71 feet square.

TABLE 26
 CUBIC OR SOLID MEASURE
United States or British

1 cubic inch = .0005787 cubic foot = .000021433 cubic yard.
 1 cubic foot = 1728 cubic inches = .03703704 cubic yard.
 1 cubic yard = 27 cubic feet = 46656 cubic inches.
 1 cord of wood = 128 cubic feet = 4 feet by 4 feet by 8 feet.
 1 perch of masonry = 24.75 cubic feet = 16.5 feet by 1.5 feet by 1 foot. It is usually taken as 25 cubic feet.

TABLE 27
 DRY MEASURE
United States Only

PINTS	QUARTS	GALLONS	PECKS	BUSHEL	CUBIC INCHES
1	.50	.125	.0625	.015625	33.6003125
2	1.	.25	.125	.03125	67.200625
8	4.	1.	.05	.125	268.8025
16	8.	2.	1.	.25	537.605
64	32.	8.	4.	1.	2150.42

1 heaped bushel = 1.25 struck bushel, and the cone must not be less than 6 inches high.

TABLE 28

ROPE AND CABLE MEASURE

1 inch = .111111 span = .013889 fathom = .0001157 cable's length.
 1 span = 9 inches = .125 fathom = .00104167 cable's length.
 1 fathom = 6 feet = 8 spans = 72 inches = .008333 cable's length.
 1 cable's length = 120 fathoms = 720 feet = 960 spans = 8640 inches.

TABLE 29

LIQUID MEASURE

United States Only

GILLS	PINTS	QUARTS	GALLONS	BARRELS	CUBIC INCHES
1	.25	.125	.03125	.000498	7.21875
4	1.	.5	.125	.003968	28.875
8	2.	1.	.25	.007937	57.75
32	8.	4.	1.	.031746	231.
2008	252.	126.	31.5	1.	7276.5

The British imperial gallon = 277.274 cubic inches or 10 pounds avoirdupois of pure water at 62° F. and barometer at 30 inches.

The British imperial gallon = 1.20032 United States gallons.

1 fluid drachm = 60 minims = .125 fluid ounce = .0078125 pint.

1 fluid ounce = 480 minims = 8 drachms = .0625 pint.

TABLE 30

FRENCH MEASURES OF LENGTH WITH U. S. EQUIVALENTS

		METERS	U. S. EQUIVALENTS
	1 millimeter . . .	0.001	0.03937 in.
10 millimeters . . .	1 centimeter . . .	0.01	0.3937 in.
10 centimeters . . .	1 decimeter . . .	0.1	3.93704 in.
10 decimeters . . .	1 METER	1.0	{ 39.3704 in. 3.2809 ft.
100 centimeters . . .			
1000 millimeters . . .			
10 meters	1 decameter	10.0	32.8087 ft.
10 decameters	1 hectometer	100.0	328.0869 ft.
10 hectometers	1 KILOMETER	1000.0	3280.869 ft.
10 kilometers	1 myriameter	10000.0	6.21377 mi.

TABLE 31

FRENCH MEASURES OF SURFACE WITH U. S. EQUIVALENTS

		SQUARE METERS	U. S. EQUIVALENTS
	1 sq. millimeter	0.000001	0.00155 sq. in.
100 sq. millimeters . . .	1 sq. centimeter	0.0001	0.155 sq. in.
100 sq. centimeters . . .	1 sq. decimeter	0.01	15.5003 sq. in.
100 sq. decimeters . . .	1 sq. METER	1.0	{ 10.7641 sq. ft.
10000 sq. centimeters }			{ 1.1960 sq. yd.
100 sq. meters	1 sq. decameter	100.0	{ 1076.41 sq. ft.
			{ 119.601 sq. yd.
100 sq. decameters . . .	1 sq. hectometer	10000.0	{ 11960.11 sq. yd.
			{ 2.4711 acres.
100 sq. hectometers . . .	1 sq. kilometer	1000000.0	{ 1196014 sq. yd.
			{ 0.38611 sq. mi.
100 sq. kilometers . . .	1 sq. myriameter	100000000.0	{ 38.611 sq. mi.

TABLE 32

FRENCH MEASURES OF WEIGHT WITH U. S. AVOIRDUPOIS EQUIVALENTS

		GRAMS	U. S. EQUIVALENTS
	1 milligram	0.001	0.0154 gr.
10 milligrams	1 centigram	0.01	0.1543 gr.
10 centigrams	1 decigram	0.1	1.5432 gr.
10 decigrams	1 GRAM	1.0	15.4323 gr.
10 grams	1 decagram	10.0	{ 154.3235 gr.
			{ 0.3527 oz.
10 decagrams	1 hectogram	100.0	{ 1543.2349 gr.
			{ 3.5274 oz.
10 hectograms	1 kilogram	1000.0	2.2046 lb.
100 kilograms	1 metric quintal		220.4621 lb.
10 quintals	1 millier or tonne		{ 2204.6212 lb.
1000 kilograms }			{ 19.6841 cwt.
			{ 0.9842 tons.

TABLE 33

FRENCH MEASURES OF VOLUME WITH U. S. EQUIVALENTS

		CUBIC METERS	U. S. EQUIVALENTS
	1 cu. millimeter . . .	0.000000001	0.000061 cu. in.
1000 cu. millimeters . . .	1 cu. centimeter . . .	0.000001	0.061025 cu. in.
1000 cu. centimeters . . .	1 cu. decimeter . . .	0.001	{ 61.02524 cu. in. 0.0353156 cu. ft.
1000 cu. decimeters . . .	1 cu. METER . . .	1.0	{ 35.3156 cu. ft. 1.308 cu. yd.
1000 cu. meters . . .	1 cu. decameter . . .	1000	1308.0 cu. yd.

TABLE 34

FRENCH MEASURES OF LIQUIDS WITH U. S. EQUIVALENTS

		LITERS	U. S. EQUIVALENTS
	{ 1 centiliter . . . } { 10 cu. centimeters }	0.01	{ 0.61025 cu. in. 0.0845 gills.
10 centiliters	1 deciliter	0.1	{ 6.1025 cu. in. 0.2114 pt.
10 deciliters	{ 1 LITER } { 1 cu. decimeter . . . }	1.0	{ 61.02524 cu. in. 0.2642 gal.
10 liters	1 decaliter	10.0	2.6418 gal.
10 decaliters	1 hectoliter	100.0	26.418 gal.

INDEX

- Air, cold, 2;
 cooled, 7;
 heated, 2, 7;
 pure, 3;
 reheated, 3, 4;
 removal of impure, 4, 5, 7.
Air spaces in refrigerator walls, 12.
Apothecaries' weight, 214.
Approximation method of estimating,
 131, 137.
Architect, 152.
Areas of circles, 184.
Arithmetic questions, 156-176.
Artificially cooled air, 7.
Asbestos paper, 3.
Asphalt floor, 177.
Astragal molding, 29, 31.
Attic stairs, 96.
Avoirdupois weight, 213.
- Balusters, cast-iron, 112;
 designs of, 112;
 dimensions of, 114;
 methods of fastening, 113.
Band molding, 27.
Baseboard, fitting, 21, 32.
Base molding, fitting of, 28.
Bathroom, finish of, 50.
Bead, molding, 30;
 staff, 73;
 stop, 30, 71.
Bedding glass, with putty, 77, 83;
 with rubber tape, 85.
Bed mold, 28;
 mitering, 28.
Bending wood, table for, 177.
Bevel of bottom rail of sash, 81.
Bill of material, 150.
Bird's beak molding, 31.
Blank contracts, 152.
Blind nailing, 19.
Blind stop, 70, 72, 85.
Blinds, hinges for, 85;
 hung between casings, 72;
 manufacture of, 85.
- Boiled oil, 121.
Bottom rail of panel work, 36.
Box flight of stairs, 100.
Box window frames, 73.
Breaking joints in flooring, 22.
Brick, cubic measurements of, 136;
 days' work in laying, 136.
Brick buildings, allowance for waste in,
 136;
 window frames for, 72.
Brickwork, 135.
Bridging, 139.
Brushes, care of, 126.
Builders, stair, 88.
Building, permit, 152;
 regulations, 152.
Built stringer, 98.
Buttress stairs, 96.
Butts, or hinges, 62, 127.
- Cable measure, 216.
Capacity of boxes, 183.
Cap molding, 28.
Carpenter and mason, 59, 133.
Carpentry, 136.
Carriages, dimensions of, 93;
 for stairs, 92;
 laying out, 92.
Casings, estimating, 144;
 of doors and windows, 23;
 of stairs, face, 94;
 spliced, 26;
 width of, 72.
Caul, for veneering, 56.
Cavetto molding, 31.
Ceiling, dado, 34;
 used in refrigerator construction, 12;
 waste in, 20.
Cellar, stairs, 96;
 sash, sizes of, 177.
Center hung sash, 74.
Central heating-plant system, 5.
Cesspool, 10;
 subsoil for, 10.
Chamber slops, disposal of, 9.

- Checking estimates, 137.
 Chimneys, data of brick, 183.
 China closets, 46.
 Circles, areas and circumferences of, 184.
 Circular panel work, 44 ;
 stair riser, 110.
 Circulation of air in refrigerators, 14.
 Circumferences of circles, 184.
 Clamps on rake dado, placing, 40.
 Clapboards, 70.
 Closed string stairs, 96.
 Closets, china, 46 ;
 clothes, 46 ;
 dry earth, 9 ;
 moth proof, 45 ;
 trunk, 46.
 Cold air ducts, 4.
 Condensation on skylight sash, 84.
 Conductor pipes of hot-air furnace, 2.
 Construction, ice house, 15 ;
 sash, 74.
 Contour of moldings, 31.
 Contract, blanks, 152 ;
 legal aspects of, 152 ;
 value of, 130.
 Contractor, hints for the, 151.
 Contractor's estimates, 131.
 Coped, joint, 76 ;
 panel work, 38.
 Coping base and picture moldings, 28.
 Cord, sash, 77, 81.
 Core for veneering, 55.
 Corner, block finish, 24 ;
 boards, estimating, 142 ;
 joints of base board, 32 ;
 laps of dado, 38.
 Cornice, estimating, 142.
 especially designed, 30.
 Cove molding, 29.
 Crown molding, 28, 29.
 Cubes of numbers, 189-213.
 Cubic, or solid measure, 215.
 Curb stairs, 96.
 Curved panels, 44 ;
 soffit, 41-43.
 Customs in making measurements, 88, 135.
 Cut stone, estimating, 135.
 Cutting for plumbers, 80.
 Cyma, recta molding, 31 ;
 reversa, 31.
 Dado, ceiling and paneled, 34 ;
 measurements of, 34 ;
 rake, 39.
 Damper in cold air duct, 2.
 Day's work in, bridging, 139 ;
 building cornice, 142 ;
 casing, 144 ;
 cutting stone, 135 ;
 excavating, 133 ;
 fitting, and fastening base, 143 ;
 hanging and locking doors, 143-144 ;
 hanging windows, 144 ;
 lathing, 145 ;
 laying brick, 136 ;
 laying floor, 143 ;
 laying stone, 135 ;
 plan members, 138, 139 ;
 plastering, 145 ;
 putting on grounds, 144 ;
 putting on siding, 142 ;
 putting up wainscoting, 143 ;
 roof members, 139, 140 ;
 setting panel work, 143 ;
 sheathing, 139 ;
 studding, 138.
 Dead air space in refrigerator, 12.
 Decimal equivalents of a foot, 185 ;
 of an inch, 186.
 Dentils, molding, 30.
 Dimensions of, stairs for public build-
 ings, 91 ;
 stair stringers, 92 ;
 stair posts, 101.
 Direct heating, 4.
 Direct-indirect heating, 4.
 Dish drainer, 49.
 Dog-leg flight, 100.
 Doorframes, 57 ;
 estimating, 142 ;
 for brick house, 58, 59 ;
 setting, 58.
 Doors, 53 ;
 doweled, 53 ;
 estimating labor on, 143, 144 ;
 fitting, 60 ;
 grades of, 55 ;
 hand of, 62 ;
 hanging of, 60 ;
 in refrigerator, 13 ;
 selection of, 54 ;
 stock sizes of, 53 ;
 veneered, 55.

- Dovetailed joint of sash, 75, 76.
 Doweled joint in panel work, 37.
 Dowels, staggered, 53.
 Draft, natural and forced, 5, 7.
 Draining pipes, 6.
 Drain tile, 11.
 Drawbored joint in sash, 76.
 Drawer case, 46;
 fitting a, 49.
 Drier, japan, 121.
 Drip of sash, 73.
 Drum, furnace, 3.
 Dry earth closet, 9.
 Dry measure, 215.
 Duct, cold air, in furnace, 2;
 cold air, in refrigerator, 14;
 foul air, 4, 5.
 Easement of handrail, 100.
 Echinus, molding, 31.
 Embellishment of stair risers, 108.
 Estimates, checking, 137;
 records of, 132;
 sub-contractor's, 131;
 summarizing, 147.
 Estimating, 130-153;
 brickwork, 135;
 casings, 144;
 circular work, 139;
 corner boards, 142;
 cornice, 142;
 doorframes, 142;
 excavations, 133;
 floors, 143;
 frame of building, 136-139;
 grading, 133;
 grounds, 144;
 hardware, 146;
 heating, 147;
 iron work, 139;
 labor, 132;
 labor on doors, 143;
 labor on windows, 144;
 painting, 146, 147;
 plastering, 145;
 price of material, 138;
 roofing, 140;
 roof members, 138, 139;
 shelving, 144;
 siding, 142;
 stairs, 144;
 stonework, 134;
 Estimating, window frames, 141.
 Excavations, 133.
 Extras, price of, 50.
 Face brick, cost of laying, 136.
 Face string, framed into posts, 100;
 of stairs, 94;
 plank, 97.
 Fan, ventilating, 7.
 Filler, wood, 124.
 Fillet, molding, 30, 31.
 Finish, bathroom, 50;
 corner block, 24;
 mitered, 24;
 plain, 25;
 shellac, 124.
 Finishing close-grained wood, 125;
 floors, 125;
 open-grained wood, 124.
 Fireplaces, 1.
 Fitting base and picture molding, 28;
 baseboard, 21, 32;
 doors, 60;
 drawer, 49;
 hinges to door, 60;
 locks, 63;
 rabbet to door stile, 60;
 sash, 80;
 threshold, 65.
 Flat color, 123.
 Floor, asphalt, 177;
 breaking joints in, 22;
 diagonal, 22;
 estimates of, 142;
 finishing, 125;
 ice house, 15;
 laying, 19;
 matched, 19;
 paint, 125;
 single, 32;
 smoothing, 20;
 square-edged, 19, 22;
 starting, 21.
 Flooring, nails in matched, 20;
 narrow or wide boards, 21;
 paper under, 20;
 selection of wood for, 21;
 waste in, 20.
 Forced draft, 5, 7.
 Frame of a building, estimating the,
 136-139;
 items for, 137.

- Frame, window, 69.
 French measures, 216-218.
 Furnace, air chamber of, 3;
 drum, 3;
 heating, 1;
 location of, 2;
 setting a, 2.
- Galvanized iron lining for refrigerators,
 14.
- Gasoline torch, 123.
- Glass, cutting, 80;
 laid with a butt joint, 83;
 setting, 84, 85.
- Glaziers' points, 78, 83.
- Glazing sash, 77.
- Glue, its use in veneering, 56.
- Glued, curved soffit, 43;
 rails for circular panel work, 44.
- Gluing rake dado, 40.
- Grading, estimating the cost of, 133.
- Gravity hinges, 85.
- Grooved and tenoned panel work,
 37.
- Grooves under the bottom of the win-
 dow sill, 71, 73.
- Grooving, door panels, 53;
 skirting boards, 95.
- Grounds, cost of putting on, 144.
- Hair felting, 13.
- Half round molding, 30.
- Hand of doors, 62.
- Handling material, cost of, 141.
- Handrail, center line of, 101;
 easement of, 100;
 forms of, 111;
 height of, 106;
 material for, 112;
 methods of fastening, 111;
 methods of splicing, 112;
 pitch of, 102.
- Handrailing, 114.
- Hanging a door, 60.
- Hardware, 50, 126;
 items to be estimated, 146;
 trimmings, 127.
- Hardwood doors, 55.
- Header of window frame, 69.
- Headroom, 88, 92.
- Heating, by fireplace, stove and hot-
 air furnace, 1;
- Heating, direct, indirect, direct-indirect
 methods, 4;
 estimate of, 147;
 hot-water, 4;
 steam, 5.
- Hinges, blind, 85;
 butts or, 62, 127;
 fitting, 60;
 gravity, 85;
 pin, 74.
- Hollow molding, 30.
- Hot-water heating, 4, 6.
- Housing skirting boards, 95.
- Hung window, 80.
- Ice chamber, 14;
 rack, 14;
 refrigerator, 12.
- Ice house, construction of, 15;
 floor, 14;
 packing ice in, 16;
 ventilation of, 16.
- Incidentals, per cent added for, 133,
 148.
- Indirect heating, 4.
- Insurance regulations, 3.
- Iron oxide, 122.
- Iron work, estimating, 139.
- Items for estimating, brickwork, 134;
 framing, 137;
 hardware, 146;
 joinery, 141;
 stonework, 134.
- Japan drier, 121.
- Joggled meeting rails of sash, 77.
- Joinery, estimating, 140, 141.
- Joint, between straight and curved
 molding, 33;
 coped, 76.
- Jointing a door, 59.
- Kerfing circular riser, 110;
 curved soffit, 41.
- Kitchen sink, 49.
- Knock down window frames, 69.
- Knots, treatment of, 122.
- Labor on material, ratio of cost of, 140.
- Landing of stairs, 91.
- Lathing, estimates for, 145.
- Laying, drain tile, 11;

- Laying, out stairs, 89;
 stone, estimates of, 135.
- Linear measure, table of, 214.
- Linen closet, 45.
- Lip molding, 28;
 mitered, 28, 29.
- Liquid measure, table of, 216, 218.
- Location of house, 130.
- Lock edge of door, jointing under the,
 62.
- Locks, 127;
 fitting, 63;
 refrigerator, 13.
- Loose pin butts, 62, 127.
- Mantels, 1, 50, 144.
- Mason and carpenter, 59, 133.
- Matched floor, 19.
- Measurements of openings, 135;
 of stair, 88;
 of stone wall, 134.
- Meeting rails of sash, 76, 80.
- Metal work, painting, 122.
- Method, in estimating, 130;
 approximation, 131;
 heating, 1;
 saw kerfing, 41.
- Middle rail of dado, 36.
- Mineral wool, insulation by, 13.
- Mitered casings, 24, 27.
- Mixing paint, 121.
- Moisture in furnace, 3.
- Moldings, 27;
 astragal, 29, 31;
 band, 27;
 base, 28;
 bead, 30;
 bed, 28;
 bird's beak, 31;
 cap, 28;
 care of, 33;
 cavetto, 31;
 contour of, 31;
 cornice, 29, 30;
 cove, 29;
 crown, 28, 29;
 cyma recta, 31;
 cyma reversa, 31;
 dentils, 30;
 echinus, 31;
 fillets, 30, 31;
 half round, 30; .
- Moldings, hollow, 30;
 joints, 33;
 lip, 28;
 mitered, 28, 29;
 nosing, 30;
 ogee, 30, 31;
 ovolo, 31;
 panel, 28;
 quality of, 33;
 quarter round, 29;
 quirk, 30, 31;
 returned upon themselves, 39;
 room, or picture, 30;
 scotia, 29;
 "spalled" corners of, 33;
 sprung, 28, 29;
 stop bead, 30, 31;
 talon, 31;
 thumb, 31;
 torus, 31.
- Mortar, ingredients of, 135, 136.
- Mortised, and tenoned, panel work, 37;
 doors, 53;
 joint of sash, 75;
 locks, 63.
- Mortises in section posts, 101, 103.
- Moth proof closet, 45.
- Mouse, use of, 82.
- Mullion window frames, 73.
- Muntins, of panel work, 36;
 sash, 75.
- Nailing, blind, 19.
- Nails, 127;
 estimates of, 138, 139, 142, 143;
 in flooring, 20, 22;
 tables of, 182.
- Nail set, 19.
- Narrow boards for flooring, 21.
- Natural draft, 5, 7.
- Newel post, 102.
- Nosing of stair treads, 30, 96, 101;
 forms of, 108;
 mitered, 109.
- Ogee, molding, 30, 31.
- Oil, raw and boiled, 121.
- Old paint, to remove, 123.
- One-pipe system, 6.
- Openings, in brick and stone walls,
 measurements of, 135;
 in ceiling for ventilation, 7;

- Openings, for stairs, 88;
 tops of, 23.
 Open string stairs, 94.
 Outside finish, cost of, 142.
 Ovolo, molding, 31.
 Oxide of zinc, 122.
- Padlocks, 63.
- Paint, area covered by, 146;
 floor, 125;
 mixing, 121;
 priming coat of, 121;
 ready mixed, 121, 122;
 removing old, 123;
 roofing, 122, 140.
- Painting, 121;
 data for painting, 180;
 estimating, 146, 147;
 green wood, 123;
 measuring surface for, 147;
 metal work, 122;
 wood which adjoins masonry, 123.
- Panel moldings, raised and sunk, 28.
- Panel work, 34;
 circular, 44;
 coped, 38;
 grooved and tenoned, 37;
 mortised and tenoned, 37;
 muntins of, 36;
 panels of, 34, 36;
 rails of, 36;
 rebated, 37;
 section of, 38;
 setting of, 38;
 stiles for, 34;
 tongued and grooved, 36.
- Panels, 36;
 curved, 44;
 swelling of, 34.
- Pantry, 46.
- Paper, asbestos, 3.
 hanging, cost of, 147;
 table of wall paper, 180.
- Parting strip of window frame, 69, 71,
 77.
- Permit, building, 152.
- Picture molding, 30;
 coping of, 28.
- Pin hinge, 74.
- Pipes, draining, 6;
 hot-air conductor, 2;
 laid before house is lathed, 8;
- Pipes, pockets in, 6;
 soil, 8;
 wrapped in asbestos paper, 3.
- Pitch board, 93.
- Pitch of, hot-air pipes, 2;
 sink drains, 11.
- Planning stairs, 91.
- Plans of house, 130.
- Plastering, estimating, 145;
 measuring for, 145;
 table of materials, 145, 181.
- Platform, flight of stairs, 99;
 of stairs, 88, 90.
- Plinth of door casings, 25.
- Plumbing, cost of, 147;
 inspection of, 8.
- Pockets in, pipes, 6;
 window frames, 71, 72, 81, 82.
- Posts, bottom square of stair, 107.
- Posts section, 100;
 gallery, 104;
 landing, 104;
 newel, 102;
 platform, 102;
 setting, 104;
 starting, 104;
 square, 108;
 winding, 102.
- Privy, 9.
- Profit, per cent added for, 133, 148.
- Pulley stiles, of window frames, 69, 74;
 of mullion frames, 73.
- Putty, its use in glazing sash, 77;
 in painting, 121;
 knife, use of, 78;
 softening of, 78.
- Quarter round, use of, 21, 29.
- Quirk, molding, 30, 31.
- Radiators, steam and hot-water, 4, 5.
- Rails, dado, 36;
 sash, 75;
- Rain-proofing skylight sash, 84.
- Rake dado, 39.
- Ratio of cost of labor to material, 140;
 gas fitting to cost of house, 147;
 hardware to cost of house, 146;
 heating to cost of house, 147;
 painting to cost of house, 147;
 plastering to cost of house, 145;
 plumbing to cost of house, 147.

- Raw oil, 121.
Ready mixed paints, 121.
Rebated panel work, 37.
Red cedar closets, 45.
Refrigerator, 12;
 doors, 13;
 ice rack for, 14;
 waste pipe, 14.
Registers, hot-air, 2.
Regulations, building, 152;
 insurance, 3.
Rim locks, 63.
Rise of stairs, 88.
Risers, construction of, 108;
 height of, 89;
 fitting to wall skirting board, 96;
 housed to receive skirting board, 97;
 skirting board fitted to, 95;
 winding, 101.
Road dust for dry earth closet, 9.
Roof, painting a metal, 122.
Roofing, estimating, 140;
 paint, 122.
Room molding, 30.
Roots, square and cube, 189-213.
Rope measure, 216.
Run of stairs, 88.
Rusty iron, painting, 122.
- Sanitation, 8.
Sash, architect's details of, 73;
 center hung, 74;
 condensation on skylights, 84;
 construction of, 74;
 cord, 77, 81;
 drawbored joints of, 76;
 drip, 73;
 fitting, 80;
 glazing, 77;
 hotbed, 82;
 joggled meeting rails, 77;
 muntins of, 75;
 rails of, 75;
 rainproofing of skylight, 84;
 scribing bottom rails of, 80;
 skylight, 82;
 stock sizes of, 79;
 store, 84;
 table of cellar, 177;
 table of sizes and weights of, 178, 179;
 weights, 81, 82;
 window, 74.
- Saw kerfing, 41.
Scotia, or cove, mitered, 29, 31;
 use of, 96.
Scratch plane, use of, 56.
Scroll for stair riser, 108.
Section posts of stairs, 100, 101, 103.
Selecting, doors, 54;
 moldings, 33;
 wood, 23.
Septic method of disposing of sewage,
 11.
Setting doorframes, 58;
 glass with beads, 84;
 glass in door, 85;
 paneled dado, 38;
 window frames, 70.
Sewage, disposal of, 8-10.
Sewerage system, 9.
Shavings, for refrigerator insulation,
 13.
Sheathing paper, use in refrigerators,
 12.
Shellac, finish, 124;
 its use on knots, 122;
 substitutes for, 125;
 thinning, 125.
Shelving, estimating, 144.
Shims, 59.
Shingled roof, painting, 123.
Shingles, table of, 181;
 staining, 123.
Shoe strip for base, 21, 32.
Shrinkage of, baseboard, 32;
 treads and risers, 108.
Siding, estimating, 142;
 thickness of, 70.
Sill, window, 69.
Single floor, 32.
Sink, drains, 11;
 kitchen, 49;
 splash board for, 50.
Sinkage of panel molding, 29.
Sizes of cellar sash, 177;
 of doors, 54;
 of windows, 178, 179;
 of window frames and sash, 79.
Skirting board, 94;
 fitted to risers, 95;
 fitted to treads, 95;
 fitted to wall, 95;
 housed, 95, 97;
 seasoning of, 95.

- Slate roof, estimating, 140;
 table of, 181.
 Soffit, curved, 41;
 splayed, 43.
 Soil pipes, 8.
 "Spalled" corners of moldings, 33.
 Specifications, 130.
 Specific gravities of building materials,
 188.
 Splash board, 50.
 Sprung molding, 28, 29.
 Square, or land measure, 215;
 stair posts, 108.
 Squared end of pulley stile, 70.
 Square-edged floor, 19;
 laying, 22.
 Squares, of numbers, 189-213.
 Stables, data of, 183.
 Staff bead, 73.
 Staggered dowels, 53.
 Staining shingles, 123.
 Stair posts, 101;
 dimensions of, 105;
 square, 108;
 stock, 105;
 stringers, 92.
 Stairs, box flight of, 100;
 buttress, 96;
 closed string, 96;
 curb, 96;
 dog-leg flight of, 100;
 easy flight of, 88;
 estimating, 144;
 forms of, 98;
 headroom of, 92;
 landing, 90, 91;
 laying out of, 89;
 measurements of, 88;
 open string, 94;
 pitch of, 102;
 planning, 91;
 platform flight of, 99;
 straight run of, 99;
 winding flight of, 99.
 Steam, exhaust and direct, 5;
 heating, 5.
 Stiles of panel work, 34;
 pulley, 69, 73, 74;
 rake dado, gluing, 39, 40.
 Striker of door, 63.
 String, face, 94;
 open, 94.
 Stringer, built, 98;
 dimensions of, 93;
 laying out, 92;
 setting, 104.
 Stock bill, 131, 150.
 Stock sizes of doors, 53, 54.
 Stone wall, measurements of, 134;
 waste in laying, 135.
 Stonework, 133;
 items for estimating, 134;
 table of, 134.
 Stool, window, 69.
 Stop, for doorframes, 57;
 bead, 30, 71;
 blind, 70, 72, 85.
 Store sash, 84.
 Stoves, 1.
 Studding, estimating, 138;
 in refrigerator construction, 12.
 Sub-contractor, 131.
 Subsill, of window frames, 70.
 Subsurface drainage, 10.
 Summarizing estimates, 147.
 Swelling of panels, 34.
 Systems, one-, and two-pipe, 6.

 Tables, 177-218.
 Tanks, contents of round, 187.
 Tenon on, face string of stairs, 100;
 risers, 101.
 Thickness of outside casings, 70.
 Threshold, fitting, 65.
 Thumb molding, 31.
 Tin roof, cost of, 140.
 Tongued and grooved, joint, 108;
 panel work, 36.
 Tothing plane, use of, 56.
 Top rail of panel work, 36.
 Tops of openings, 23.
 Torus molding, 31.
 Traps under sink, 11;
 for refrigerator waste pipe, 14.
 Treads, construction of, 108;
 fitted to wall skirting board, 95;
 horizontal distance covered by, 88;
 housed to receive skirting board, 97;
 skirting board fitted to, 95;
 width of, 90;
 winding, 99, 104.
 Trimmings, hardware, 127.
 Troy weight, 214.
 Trunk closet, 46.

- Two-pipe system, 6.
- Varnish, thinning, 126.
- Varnished work, cost of, 146.
- Veneered doors, 55.
- Veneering 56.
- Ventilating, by fireplaces, 1;
by forced draft, 5, 7.
- Ventilation, 6;
contract sublet for, 7;
of an ice house, 16.
- Vents, foul air, 5.
- Vertical dimensions of stair posts, 103,
105.
- Wall paper, table of, 180.
- Wall skirting board, 95.
- Warping panels, 45.
- Waste, allowance for, 142;
in brickwork, 136;
in flooring, 20;
in stonework, 135.
- Waste pipe in refrigerator, 14.
- Water-closet, 10.
- Water supply, contamination of, 9, 10.
- Wearing floor, fitting to baseboard, 32;
paper under, 20.
- Weather strip on refrigerator door, 13.
- Wedges, in joint of sash, 75;
used in stair building, 95, 97.
- Weight, apothecaries', 214;
avoirdupois, 213;
troy, 214.
- Weights, of windows, 178, 179;
of building materials, 188.
- White lead, its use in paint, 121.
- Width of stair tread, 90.
- Winding flight, 99;
dimensions of, 91;
risers, 101, 104.
- Window, casement, 74;
mullion, 73, 74;
sash, 74;
sill, grooved, 71, 73;
weights and sizes of windows, 178,
179.
weights, space for, 72.
- Window frames, 69;
architect's details of, 73;
box, 73;
Eastern and Western styles, 70;
estimating, 141;
for brick buildings, 72;
mullion, 73;
setting of, 70.
- Windows, labor in fitting, 144.
- Wood, filler, 124;
finishing, 124;
for finishing, 23;
for floors, 21;
mantels, 50;
table for bending, 177.
- Woodwork, special, 50, 144.
- Wreath, laying out, 114.
- Zinc lining for refrigerators, 14.