

KING'S SERIES IN WOODWORK AND CARPENTRY

CONSTRUCTIVE CARPENTRY

BY

CHARLES A. KING

DIRECTOR OF MANUAL TRAINING

EASTERN HIGH SCHOOL, BAY CITY, MICHIGAN

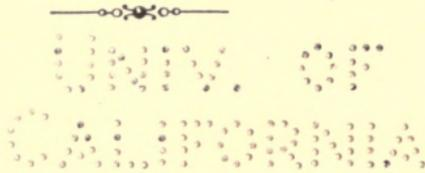

NEW YORK ∴ CINCINNATI ∴ CHICAGO
AMERICAN BOOK COMPANY

TH 5606
K5.

KING'S SERIES IN WOODWORK AND CARPENTRY

- ELEMENTS OF WOODWORK**
- ELEMENTS OF CONSTRUCTION**
- CONSTRUCTIVE CARPENTRY**
- INSIDE FINISHING**
- HANDBOOK FOR TEACHERS**

Pres' left.

**COPYRIGHT, 1912, BY
CHARLES A. KING.**

ENTERED AT STATIONERS' HALL, LONDON.

W. P. I

TO THE
LIBRARY OF
THE UNIVERSITY OF
TORONTO

PREFACE TO THE SERIES

THIS series consists of five volumes, four of which are intended as textbooks for pupils in manual-training, industrial, trade, technical, or normal schools. The fifth book of the series, the "Handbook in Woodwork and Carpentry," is for the use of teachers and of normal students who expect to teach the subjects treated in the other four volumes.

Of the pupils' volumes, the first two, "Elements of Woodwork" and "Elements of Construction," are adapted to the needs of students in manual-training schools, or in any institution in which elementary woodwork is taught, whether as purely educational handwork, or as preparatory to a high, or trade, school course in carpentry or vocational training.

The volumes "Constructive Carpentry" and "Inside Finishing" are planned with special reference to the students of technical, industrial, or trade schools, who have passed through the work of the first two volumes, or their equivalent. The subjects treated are those which will be of greatest value to both the prospective and the finished workman.

For the many teachers who are obliged to follow a required course, but who are allowed to introduce supplementary or optional models under certain conditions, and for others who have more liberty and are able to make such changes as they see fit, this series will be found perfectly adaptable, regardless of the grades taught. To accomplish this, the material has been arranged by topics, which may be used by the teacher irrespective of the sequence, as each topic has to the greatest extent possible been treated independently.

The author is indebted to Dr. George A. Hubbell, Ph.D., now President of the Lincoln Memorial University, for encouragement and advice in preparing for and planning the series, and to George R. Swain, Principal of the Eastern High School of Bay City, Michigan, for valuable aid in revising the manuscript.

Acknowledgment is due various educational and trade periodicals, and the publications of the United States Departments of Education and of Forestry, for the helpful suggestions that the author has gleaned from their pages.

The illustrations in this Series, with the exception of the photographs in "Elements of Woodwork" and "Elements of Construction," are from drawings made by the author.

CHARLES A. KING.

BAY CITY, MICHIGAN.

PREFACE TO CONSTRUCTIVE CARPENTRY

BEFORE undertaking the work included in the following pages, the student should have passed through that contained in "Elements of Woodwork" and "Elements of Construction," or their equivalent.

In preparing the material for this book, it has been the author's first purpose to arrange and present the subjects in such a manner that they will be easily adaptable to use in technical schools for students of architecture and engineering, and in trade and industrial schools for the teaching of the principles and methods of building construction, to students who plan to make carpentry a means of livelihood.

The matter as arranged has special reference to the laying out and planning of the construction of wooden buildings, for the foreman as well as for the one who is to work under his direction. The important problems met with in preparing a house for the inside finish are discussed, and the relation between the carpenter and other mechanics is explained.

The teacher should see that there is a select library for the use of the students, including the leading trade periodicals, from which should be selected subjects for discussion, research, and essays bearing upon the different stages of the work.

The method of teaching the use of the steel square was devised by the author to meet classroom conditions; the formulas and instruction given may be applied to any pitch or plate angle or to any combination of them.

TABLE OF CONTENTS

	PAGE
CHAPTER I. MASONRY, FOUNDATIONS. — 1. Building sites ; 2. Subsoil ; 3. Laying out the foundation ; 4. Excavations ; 5. Ledges ; 6. Footing courses ; 7. Stonework ; 8. Damp proofing ; 9. Brickwork ; 10. Bonding ; 11. Anchors ; 12. Openings ; 13. Corbelling ; 14. Brick walls ; 15. Chimneys ; 16. The carpenter and the mason	1
CHAPTER II. FORMS OF CONSTRUCTION. — 17. The full frame ; 18. The half frame ; 19. The balloon frame ; 20. Sills ; 21. Corner posts ; 22. Braces ; 23. Floor joists ; 24. Studding ; 25. Porch construction ; 26. Trusses ; 27. Timbers ; 28. Selection of timber	23
CHAPTER III. MILL CONSTRUCTION. — 29. Introduction ; 30. Details	44
CHAPTER IV. THE CARPENTER'S STEEL SQUARE, CARPENTER'S GEOMETRY. — 31. Steel square ; 32. Bevel board ; 33. To mark divisions ; 34. To lay out regular polygons ; 35. To bisect an angle ; 36. To find the center of a circle from three given points ; 37. To construct the greatest square within a given circle ; 38. To construct a square ; 39. To construct a circle which shall equal the area of two given circles ; 40. To octagon a given timber ; 41. Given the side of an octagon, to find the width ; 42. Given the side of a hexagon, to find the width ; 43. Given the side of an octagon, to find the diagonal ; 44. Given the side of a hexagon, to find the diagonal ; 45. Given the width of an octagon, to find the length of a side ; 46. Given the width of a hexagon, to find the side	53
CHAPTER V. ROOF CONSTRUCTION. — 47. Pitches of roofs ; 48. The different forms of roofs ; 49. The plan of the roof ; 50. The common rafter ; 51. Lookouts ; 52. The ridge ; 53. Hip rafters ; 54. Valley rafters ; 55. Jack rafters ; 56. Cripple rafters ; 57. Collar beams ; 58. Struts ; 59. Purlins and hoppers ; 60. Octagon rafters ; 61. Hexagonal rafters ; 62. The king-post roof ; 63. Backing an octagon hip rafter ; 64. Octagon cheek cuts ; 65. Irregular roofs ; 66. Curb roofs ; 67. Curvilinear hips ; 68. Flat roof ; 69. Dormer windows	68

	PAGE
CHAPTER VI. BOARDING IN. OUTSIDE FINISH. — 70. Boarding in; 71. Cornices; 72. Gable finish; 73. Outside finish; 74. Con- ductors; 75. Finials; 76. Circular gutters; 77. Rake moldings; 78. Siding a circular tower; 79. Scribing; 80. Dome roof . . .	108
CHAPTER VII. ROOF COVERINGS. — 81. Shingles; 82. Flashing; 83. Metal roofs; 84. Slate roof; 85. Gravel roofs . . .	128
CHAPTER VIII. PLASTERING. — 86. Laths; 87. Corner finish; 88. Grounds; 89. Plastering; 90. Back plastering; 91. Dead- ening	143
GLOSSARY OF TERMS USED IN ARCHITECTURE AND CARPENTRY . . .	153
INDEX	171

LIST OF ILLUSTRATIONS

FIG.	PAGE
1. Location of a House upon an Irregularly Shaped Lot	3
2. Laying out the Foundation	4
3. Large Square for Laying out Foundations	5
4. Building a Foundation upon a Ledge	7
5. Rubble Foundation built upon a Hillside	8
6. Coursed Ashlar	9
7. Broken Ashlar	10
8. Damp Proofing	11
9. Inside Blind Drain	12
10. Inside Open Drain	13
11. English Bond	15
12. American Bond	15
13. Brick Veneering	16
14. Strap Anchor	16
15. Plate Anchor	16
16. Lintels and Rowlock Arches	17
17. Corbelling	17
18. Wooden Plate for the Top of a Brick Wall	18
19. Mortised Joint, Drawbored	23
20. Full Frame House	24
21. Balloon Frame	25
22. Framing of Sills at the Corners	27
23. Beveled Shoulder Joint	28
24. Joint between the Corner Post and Sills	29
25. Built Corner Posts	29
26. Ledger Board, or Ribband	29
27. Position of the Framing Square in Finding the Length of a Brace	29
28. Beveled Shoulder Brace Joint	30
29. Sizing Floor Joists to fit Sills and Girders	31
30. Bridging	33
31. Partitions	34
32. Straightening a Crooked Stud	35

FIG.		PAGE
33.	Porch Construction	36
34.	Ramped Rail	37
35.	Trussed Girder	38
36.	Girder stiffened by Rods	38
37.	Built Trussed Girder	38
38.	Fitch Plate Girder	39
39.	Scissors Truss	39
40.	Howe Truss	40
41.	Floor Plan of a Section of a Mill	45
42.	Cross Section of Above Mill	46
43.	Longitudinal Section of Above Mill	47
44.	Construction of Above Mill at Wall and Posts	48
45.	The Carpenter's Steel Square	54
46.	Diagonal Scale of 100ths of an Inch	55
47.	Dividing a Board into Equal Spaces	56
48.	Construction of a Circle with a Steel Square	57
49.	Construction of an Equilateral Triangle	57
50.	Construction of a Hexagon	58
51.	Construction of a Rectangle	58
52.	Construction of an Octagon	59
53.	Bisecting an Angle	59
54.	Construction of a Circle from Three Given Points	60
55.	Construction of the Greatest Possible Square within a Given Circle	60
56.	Construction of a Square One Half of the Area of a Given Square	61
57.	Construction of a Square which shall Equal Twice the Area of a Given Square	61
58.	Construction of a Circle Equal to the Area of Two Given Circles	61
59.	To Octagon a Given Timber. Method 1	62
60.	To Octagon a Given Timber. Method 2	62
61.	To Octagon a Given Timber. Method 3	62
62.	To Octagon a Given Timber. Method 4	63
63.	Given the Side of an Octagon, to find the Width	63
64.	Given the Side of a Hexagon, to find the Width	64
65.	Given the Side of an Octagon, to find the Diagonal	64
66.	Given the Width of a Hexagon, to find the Side	65
67.	Roof Dimensions	68
68.	Roof Pitches	68
69.	Different Forms of Roofs	70
70.	Roof Plan	70
71.	Common Rafters	71

LIST OF ILLUSTRATIONS

xi

FIG.	PAGE
72. Laying out the Plumb or Ridge Cuts of a Common Rafter	73
73. Laying out the Seat or Plate Cut of a Common Rafter	75
74. To find the Length of the Lookout	77
75. Allowance for Thickness of the Ridge	78
76. Diagonal of the Thickness of the Hip Rafter	79
77. Ridge and Hip Rafters	80
78. Method of Finding the Hip Pitch Line of the Thickness of the Ridge	82
79. Method of Finding the Cheek Cuts	84
80. The Graphic Method of Finding the Lengths and Angles of Rafters	86
81. Plate Cut of Valley Rafters	86
82. Backed Hip Rafter ; Square Hip Rafter	87
83. Method of Laying out the Backing	87
84. Method of Finding the Lengths of Jack Rafters	89
85. Method of Finding the Lengths of Collar Beams	92
86. The Strut	93
87. Method of Finding the Length of a Strut	93
88. Method of Laying out Purlins and Hoppers	95
89. Second Method of Laying out Purlins and Hoppers	96
90. Third Method of Laying out Purlins and Hoppers	96
91. Fourth Method or the Graphic Method of Laying out Purlins and Hoppers	97
92. Apex of an Octagonal Roof	98
93. Apex of a Hexagonal Roof	99
94. A King-Post Roof	100
95. A King-Post and Finial	100
96. Laying out a Curvilinear Hip Rafter	103
97. A Dormer Window	104
98. A Lift Window	104
99. Boarding In	108
100. Scaffold Bracket	109
101. Open Cornice	110
102. Box Cornice	111
103. Eaves Troughs or Gutters	112
104. Lengthening Moldings	113
105. Corner Boards	114
106. Mitered Clapboards	114
107. Forms of Siding	115
108. Flashing over Openings	116
109. Water Table	117

FIG.		PAGE
110.	Curved Moldings	118
111.	Scarfig a Molding for Bending	119
112.	Laying out a Rake Molding	119
113.	Rake Box Cornice	120
114.	Rake Miter Box	121
115.	Siding a Circular Tower	122
116.	Scribing	123
117.	Boarding a Dome Roof	124
118.	Shingling a Roof	128
119.	Scaffolds for Shingling	129
120.	Hip Shingling ; Methods 1 and 2	131
121.	Hip Shingling ; Method 3	132
122.	Valley Shingling	133
123.	Repairing a Shingled Roof	134
124.	Shingle Nail Cutter	134
125.	Flashing a Dormer Window	134
126.	Skylight Flashing	135
127.	Saddle or Cricket Flashing	135
128.	Counter Flashing	136
129.	Metal Roofs : Standing Seam, Flat Seam	137
130.	Lathing an Inside Corner	143
131.	Lathing a Straight Wall	144
132.	Lathing on a Wide Timber	144
133.	Metal Corners	145
134.	Plaster Bead	146
135.	Grounds for Plastering	146
136.	Deadening a Floor ; Method 1	150
137.	Deadening a Partition	150
138.	Deadening a Floor ; Method 2	151

CONSTRUCTIVE CARPENTRY

CHAPTER I

MASONRY, FOUNDATIONS

1. **Building sites.**—(A.) In selecting the site for a dwelling, the most important considerations are those relating to its hygienic aspects. In order to insure that the flow of the surface water will be away from the house, the latter, if possible, should be located so that the land will fall away from it in all directions. It should not be located near a pool of stagnant water, as malaria and mosquitoes may result; nor should it be built in a deep grove, as the house is liable to be damp, which, aside from being unhealthful, tends to promote the decay of the building. This does not mean that there should be no trees near the house, but that the foliage should not be so thick as to prevent plenty of sunlight from reaching the building, or to impede the free circulation of air.

(B.) If practicable, the house should be set at an angle to the coldest prevailing winds, so that their full force will not be felt. A clump of pines, or similar trees, will be of great value in breaking the force of the wintry winds.

2. **Subsoil.**—As the subsoil has a great deal to do with the foundation, it is important to know the nature of the ground upon which the building rests, though it is usually

the architect who decides the depth and form of the foundation, and the width of the footing course. If the subsoil is not known, and a large building is to be erected, the architect generally will sink shafts some distance below the bottom of the proposed foundation, in order to ascertain the nature of the soil which is to support the building.

Rock makes the most solid foundation bed, but is apt to cause trouble in damp-proofing. The architect and builders should be careful not to mistake a large boulder for bed rock.

Clay, if hard, will usually be found sufficiently firm for any ordinary building, as it will support from $1\frac{1}{2}$ to 6 tons per square foot according to its nature. It should, however, be well drained for, if clay lies upon a slanting substratum, it is apt to slip when wet. (See Fig. 5.)

Gravel is the ideal soil upon which to build, providing it is compact, as it is not affected by water and very little by frost. It has a resistance of from 4 to 8 tons per square foot and, if the footing courses are properly estimated and the foundation well put in, will stand any load with safety.

Sand is useless as a foundation bed, unless it is confined laterally, in which case it is about as satisfactory as gravel in its resistance to frost and water, and will safely support from 2 to 4 tons per square foot.

If a building is to be erected upon *mud* or *silt*, piles should be driven. These are round, straight logs, usually of oak, hard pine, or cypress, though elm and spruce are often used. They should be driven into the ground to the desired depth by means of a pile-driving machine and, if not exposed to alternations of wet and dry, they are practically ever-

lasting. Sometimes foundations are laid upon mud by extending the footing course to give a very broad bearing. One of the methods of doing this is to lay plank in several layers, crossing each alternate layer, and building sufficiently thick to insure rigidity. This method has been used successfully in building upon marsh lands. Another method is to build a form which is then filled with concrete.

3. **Laying out the foundation.** — (A.) In laying out the foundation of a building where the lots are platted and the streets laid out, the front of the house generally should be parallel to the side of the lot which fronts the principal street. If the lots are narrow and the dividing lines extend at an angle with the front, the house is usually set parallel with the line separating the lots, thus bringing the front at an angle with the street, but square with the dividing line, as in Fig. 1, which shows a dwelling house located upon an irregularly shaped corner lot. In this way the waste of land is reduced to a minimum.

In places where there are building laws, the minimum distance at which the house may be set from the front of the lot usually is regulated, but in any case, it adds to the good appearance of a street to have the fronts of all of the houses upon the same line, and anything which improves the appearance of a neighborhood generally will increase the value of the property there.

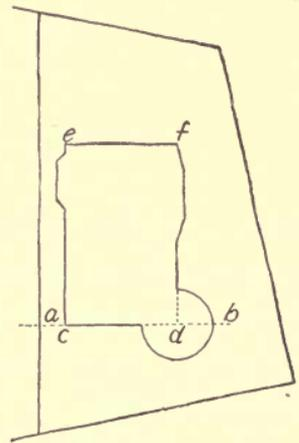

FIG. 1. — LOCATION OF A HOUSE UPON AN IRREGULARLY SHAPED LOT.

(B.) Having located the line of the front of the house (*ab*, Fig. 1), decide upon the relation of the corner *c* to the nearest side of the lot. With *cd* as basis, lay out the greatest rectangle possible to obtain from the plan of the house, as shown by the corners *c*, *d*, *e*, *f*.

In order to obtain the exact corners of the rectangle, it is necessary to stretch lines, the intersections of which will mark the corners *c*, *d*, *e*, *f*. That these lines may be stretched permanently and accurately, batter boards (see

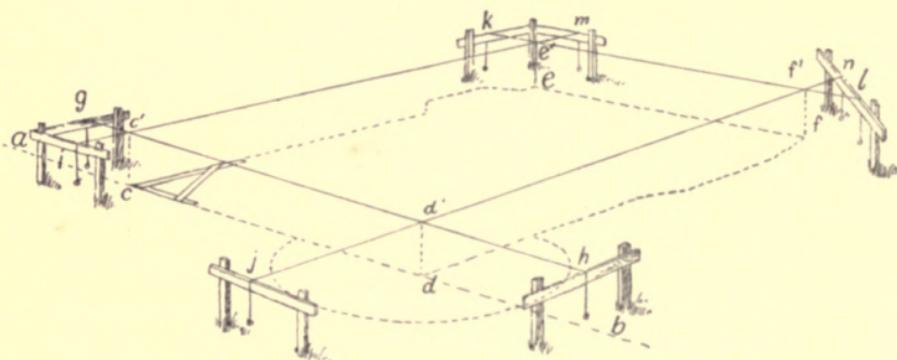

FIG. 2. — LAYING OUT THE FOUNDATION.

Glossary) should be erected as shown in Fig. 2, not less than five feet from the sides of the house at the corners which the approximate measurements have located. Three forms of batter boards are shown, the form at *c* and *e* being generally used, as it is more rigid than the others.

After the line of the front of the house *cd* is located, the line *gh* should be stretched by means of a piece of strong, small cord about two feet longer than the distance between the batter boards, dropped into the saw cuts which have been made at exactly the right places to locate the line permanently. Tie a stone at each end

of the cord to keep it stretched tightly, and to allow it to be removed easily.

Locate saw cut *i* in the front batter board at a distance equal to that of the side of the lot from the side of the house, and throw one end of the cord *m* over the rear batter board, each end of the cord being weighted with a stone. The saw cut should not be made in the rear batter board at this time, as the cord may have to be moved when squaring though, if the front line is accurately located, *m* will be parallel to the side of the lot. Measure from the cut *i*, parallel with the line *cd*, the exact length of the foundation of the front of the house (*cd*), and make saw cut *j* in the other front batter board; from this another line *jn* should be stretched to the corresponding rear batter board, and weighted. Parallel to *gh*, line *kl* should be stretched to locate the back of the foundation, saw cuts having been made so that the line may be dropped instantly into its place at either end.

It now remains only to make lines *im* and *jn* parallel to each other and square with *gh* and *kl*. This may be done by laying a square (see Fig. 3) upon the ground as at *c*, so that the tongue and line *gh* will exactly coincide, and by bringing line *im* to coincide with the blade of the square. Measure across the back and make line *jn* parallel with *im*.

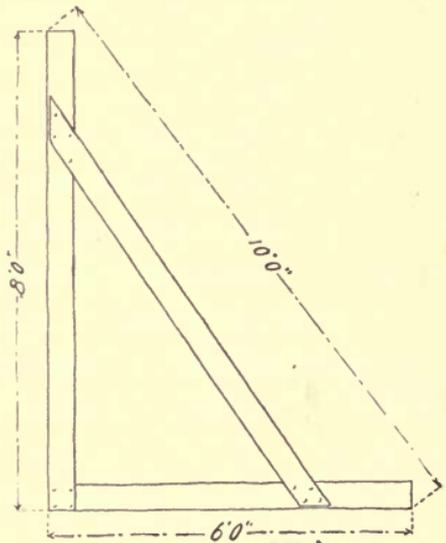

FIG. 3. — LARGE SQUARE FOR LAYING OUT FOUNDATIONS.

If the work has been done with accuracy, the intersections of the lines at c , d , e , f will denote the corresponding corners of the building; but as it is most important that the building be perfectly square, the work should be proved by measuring the diagonals ($c'f'$, $d'e'$) between the intersections of the lines: if they are equal, they are the corners of a perfect rectangle; if not, move the two points m and n simultaneously in the same direction, until the diagonals are exactly the same length. Having accurately located points m and n , make saw cuts in the batter boards to receive the lines, which may then be removed and replaced as often as necessary. Many carpenters doing the above work use, instead of a steel square, a large square, made like Fig. 3. After the great rectangle is located, the smaller angles and projections in the foundation may be placed by measuring.

It is quite a common custom for the mason and the carpenter to lay out the foundation in the presence of the architect; if a large and important building is being laid out, it is a wise plan to call in the services of an engineer to insure accuracy, and to locate points from which levels may be taken.

4. **Excavations.** — The excavation should be enough larger than the foundation walls at the bottom to allow the footing course to project beyond them and to include, if necessary, a drain to prevent the water in the ground from running into the cellar. Since every inch added to the excavation means that a great deal more earth will have to be removed, this needs careful thought. The sides of the excavation should slope enough to insure that there will be no caving in of the bank.

Finally, the footing course should be far enough from the surface to be several inches below the deepest frost line, and, to insure that the foundations of large buildings will never be thrown out of shape by the action of frost or water, the course should rest still deeper.

5. Ledges. — A ledge never should be allowed to run through the cellar wall, as water will seep into the cellar through minute crevices in the rock ; it should always be cut off, and the cellar wall built inside of it, as shown in Fig. 4. An open tile drain should be laid below the level of the cellar floor to carry away the water in the ground, as shown at *a*. This drain should be connected with the sewer by a trap outside the foundation wall, or if in an isolated district where there is no sewer, it should be carried to the nearest available spot giving sufficient pitch to allow the water to run off. If a ledge comes through the cellar floor, water may enter, as the moisture in the ground outside will force its way up through it. To prevent this, the floor should be dug away, and a Portland cement floor laid above it. (See Topic 8.)

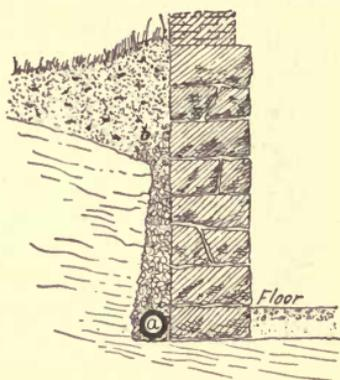

FIG. 4. — BUILDING A FOUNDATION UPON A LEDGE.

6. Footing courses. — Unless the footing course rests upon solid rock or upon clay, it should be considerably wider than the foundation upon each side, and should be made of large flat rocks, which have a good bearing upon the earth beneath. If a house is built upon a sidehill, the excavation for the footing course should

be in steps, as shown in Fig. 5, to guard against slipping down hill.

If the footing course rests partly upon a ledge, the bearings upon the earth should be very broad, in order to furnish as nearly as possible the same resistance as the ledge.

In laying the foundation for an ordinary house, the stones frequently are laid dry, and the mortar pushed into the cracks after the wall is entirely laid. This is called "pointing," and is a cheap way of doing work; but it is the

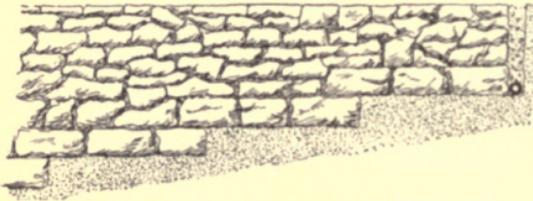

FIG. 5. — RUBBLE FOUNDATION, BUILT UPON A HILLSIDE.

method followed commonly in that class of work known as "Jerry building." If the wall is well bonded in laying, this method may be satisfactory for a light dwelling house,

but it will never be so safe as if the work had been done properly.

In constructing the foundation for an important building, each stone should be laid in mortar stiff enough to prevent the weight from forcing all the mortar out from the high places between the stones, and allowing the upper stones to rest directly upon those below them. If this happens, the shrinkage of the mortar in drying will leave the upper stones resting upon points, thereby lessening the stability of the wall. Little dependence should be placed upon stone chips, or "spalls," to make a stone rest firmly, as these often work out.

Foundations of heavy buildings sometimes are made of twisted bars, or railroad iron, or of I beams laid cross-

ways in different courses, with concrete worked into all the corners and angles, and thoroughly tamped to form a compact mass.

Concrete for work which is to support heavy loads should be made of 1 part Portland cement, 2 parts sand, and 4 or 5 parts broken stone. A cheaper grade of cement sometimes will give satisfactory results, though it is never so reliable as a standard and carefully tested brand of Portland cement.

7. Stonework. — The stonework of a building may be of several different styles of finish, of which we will discuss only those in most common use.

Rubblework is the name applied to rough unhewn stones laid as they may fit each other best. A bond stone should run through the wall about every 5 square feet. Underground foundations of this type are frequently laid. (See Fig. 5.)

Ashlar is the term applied to all stonework which has a finished face. Oftentimes a veneer of ashlar is used as a facing for a rough wall of either stone or brick, and is held in place by bond irons, or by faced bond stones which are built into the wall at frequent intervals.

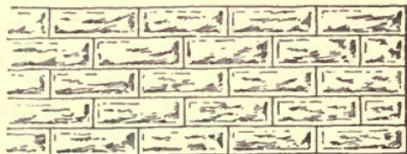

FIG. 6. — COURSED ASHLAR.

Coursed ashlar is the term applied to work formed by stones laid as shown in Fig. 6. The horizontal or bed joints are unbroken except at the openings.

Broken ashlar is the term applied to stonework laid as in Fig. 7.

A *draft* is a line cut around the face of a stone as in

Fig. 6, the face being first pitched off so that it is square with the bed.

Pitch, or *rock face*, means that the face is cut to a line, or "pitched" square with the bed of the stone and out



FIG. 7. — BROKEN ASHLAR.

of wind, leaving the rest of the face as it came from the quarry, or "quarry faced." If a stratified stone is used, such as limestone, it should be laid upon its natural bed, for when the stone is

exposed to the weather, it absorbs a great deal of moisture, and if the bed is laid vertically, freezing will cause the layers to scale off.

8. Damp proofing. — Dampness in a cellar may be due to different causes; generally the safest way to insure a reasonably dry cellar is to drain it from the outside, thereby preventing the water from soaking through the foundation. This may be done by laying drains of open-joint tiling outside of the cellar wall, as at *a*, Fig. 4, the bottom of the tiling being at least 6 inches lower than the level of the cellar floor at the highest place in the drain, with the pitch toward the outlet of at least 3 inches to every 50 feet in its length, and by connecting them with the sewer by a trap outside of the cellar wall, to prevent sewer gas from entering the house by way of the drain tile. The tiling or drain pipe should be laid straight upon a carefully prepared bottom, with no low places in it where sediment may collect and thereby impair the efficiency of the drain.

Above the drain, to about two feet or less from the grade line, the trench outside of the foundation wall

should be filled with broken stone or coarse gravel, as at *b*, Fig. 4, which allows the water in the ground and the surface water to go directly to the bottom of the trench and into the drain, thus preventing the water with which the earth is filled from standing against the wall of the cellar during a long wet spell. In order to assist the wall to resist the dampness, Portland cement should be plastered upon the outside, as at *a*, Fig. 8. All places

which would catch water and conduct it into the wall, as at *b*, should be carefully cemented, so that the water will be carried away. It is a good plan to give the outside of the walls a thick coat of asphalt pitch underground, as at *c*, directly upon the stone, or cement if that is used. Either of these methods of waterproofing will be satis-

factory if well done, and, in very wet locations, both are sometimes used, the asphalt being outside of the cement.

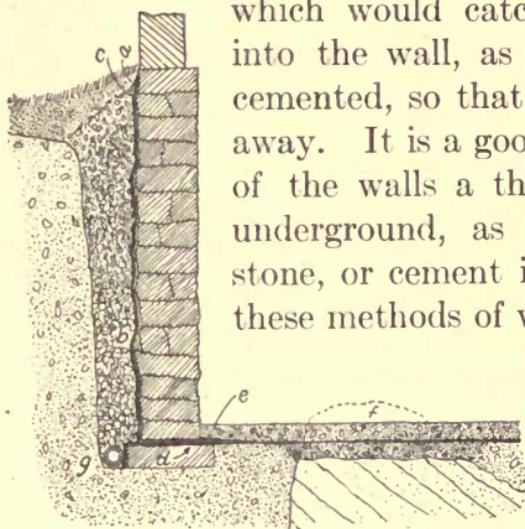

FIG. 8. — DAMP PROOFING.

In constructing any kind of building in a damp location, it is wise to take all possible precautions against dampness entering the basement. The top of the footing course should be well covered with a thick coating of asphalt as at *d*, Fig. 8; a piece of asphalt paper should be pressed into all the inequalities, and allowed to project several inches into the cellar, as at *e*, to connect with the asphalt which is to make the cellar floor waterproof. After this another coat of pitch should be added and the as-

phalt floor spread. The asphalt should be below the level of the cellar floor, and the foundation laid upon it, as usual; in wet places the foundation should be laid in cement and carefully pointed throughout. If a ledge comes through a cellar floor, as at *f*, it should be cut down at least six inches below the level of the finished floor and, to obtain the best results, should be covered with at least two inches of dry sand and broken stone well pounded down and leveled off. Over this should be spread evenly about a half inch of asphalt continuous with *d*. Above this should be laid the concrete floor. If this damp proofing is well done, there is little likelihood that the cellar will be damp from the water in the ground passing through the walls or floor.

A cellar often is damp because during the construction proper precautions were not taken to prevent it. In such

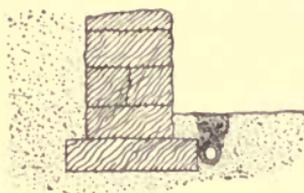

FIG. 9. — INSIDE BLIND DRAIN.

an event, if it is plain that the water comes through the walls, and since it is considerable expense to lay a drain as at Fig. 8, after the house is built, it will help greatly to dig a trench around the cellar inside of the wall as in Fig. 9, and to lay a *tile* or *blind*

drain with the pitch as described above, connecting it with the drain outside of the wall by means of a trap. The trench should then be filled with broken stone, and made flush with the cellar floor. If all the moisture comes through the floor, this method will only help; the floor should be cemented as described elsewhere.

Another method of keeping the moisture where it belongs is to cement the cellar floor, and the walls for two or

three feet from the floor or as high as the surface of the ground. If Portland cement is used, and sufficient ventilation is provided, this generally gives fair satisfaction, unless the house is in a very damp location. Unless the draining is properly done while the house is being built, it will be difficult to make a perfectly dry cellar.

If it is not desirable to go to more expense than that of cementing the floor after the cellar is finished, lay a tapered piece of joist, 3" \times 4", or 3" \times 5", with its bottom at the desired pitch, as close as possible to the inside of the cellar wall, and cement around it, as in Fig. 10. After the cement is set the joist may be removed, leaving a trench or *open drain* around the cellar, which, if connected with the drain outside, will carry off any water coming in during a long rain. Any connection of this sort with the sewer should be made with a trap, to prevent sewer gas from coming into the house. Neither of these inside drains is recommended except as a makeshift, as they will only carry off the water, and will not prevent the cellar, on account of the wet walls and floor, from being very damp.

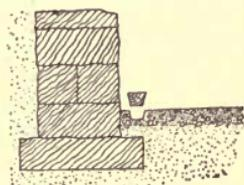

FIG. 10. — INSIDE OPEN DRAIN.

9. Brickwork. — *Brick* in common use has far greater resistance to fire than has stone and is for that reason, if for no other, better adapted for use in the construction of warehouses, common buildings, chimneys, and for many other purposes in building and engineering work.

Brick is used more than any other building material, except wood, though it appears that concrete sometime will take first place. For a better grade of work *face brick*

is used, but while it is much finer in appearance, it does not stand fire, being speedily destroyed if exposed to a great heat. It is made in innumerable designs, and in a great variety of colors, and is principally used for the face walls of buildings, and for decorative purposes in the interiors of large rooms, armories, libraries, etc., where the effect of a brick wall is appropriate.

Fire brick should be used where great heat is to be resisted.

A good brick for general use should give a clear, ringing sound if struck with a hammer, and if soaked for twelve hours should not absorb more than 10 per cent of its weight in water. In laying brick the joints should be level and plumb, and not more than $\frac{5}{16}$ " thick. Upon the best work, it is the custom to make a *shove joint*, that is, the brick is bedded in mortar, and shoved against the one next to it, thus filling the vertical joint; upon common work, the brick simply is bedded, and the plumb joints partly filled with the cleanings from the outside of the wall and with mortar from the bedding of the next course.

Mortar for brick laying should be mixed in the proportions of one of lime to three of sand, though this will vary according to the strength of the lime.

In building thick walls, piers, etc., *grouting* is sometimes done; this consists in laying the outside walls in mortar or cement, the inside being filled with "bats" or pieces of brick, and in pouring in after every second or third layer a thin mixture of mortar or cement over the inside courses. If the bricks are thoroughly wet before laying, and if the work is done well, satisfactory results may be obtained, though otherwise this method is worthless.

Bricks should be sorted for colors in fine work, and the poorer colors and quality used where they will be less conspicuous. Decorative effects are often obtained by laying the different colors in surface design.

If bricks are laid in very dry weather, they should be thoroughly wet before laying, for if laid dry, they absorb the moisture of the mortar before it has time to set.

It is not wise to lay brick in very cold weather, for if the mortar freezes the work will be worthless. It is sometimes necessary to lay brick in winter, in which case everything should be heated, and the walls should be kept covered, to hold the heat as long as possible, so that the mortar may set before it freezes. This is sometimes satisfactory, but the result is always doubtful.

10. Bonding. — (A.) *Bonding* is the term applied to the method of laying bricks by which the inside and outside walls are fastened together and at the corners to strengthen them. Bricks which are laid with their ends to the face of the wall are called *headers*, and

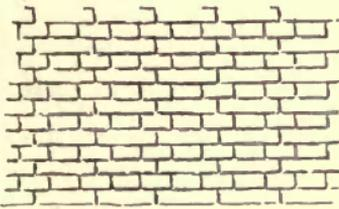

FIG. 11. — ENGLISH BOND.

those showing their edges are called *stretchers*.

The *English bond*, Fig. 11, consists of alternate courses of headers and stretchers, and is the strongest bond, though rarely used in this country except upon engineering works and important buildings.

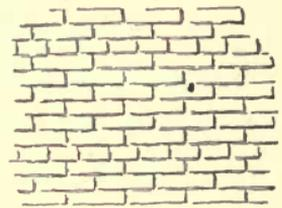

FIG. 12. — AMERICAN BOND.

The bond commonly used is known as the *garden*,

American, or running bond (Fig. 12), which is made by laying from five to seven courses of stretchers between the courses of headers.

There are many forms of patent *metal bonds*, which are used to hold walls together, especially a face wall upon which it is desirable that no headers shall show.

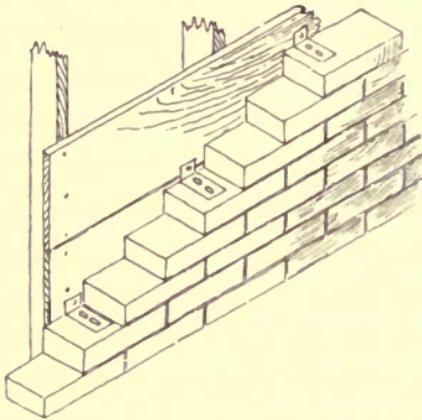

FIG. 13. — BRICK VENEERING.

(B.) A *brick veneered building* is one having a layer of bricks laid outside of a strongly braced wooden frame, which is boarded in to make it as rigid as possible and to which the veneer is fastened by means of an iron bond as shown in Fig. 13. This form of construction has many advantages and is increasing in use.

II. Anchors. — *Anchoring* is the method of fastening brick walls to prevent them from falling outward. One method is shown in Fig. 14, in which the floor joists are splayed or cut as illustrated, to allow the floor to fall in case of a fire, so that the wall will not be pulled over. The anchor *a* is fastened, as indicated, upon the side near the bottom edge of the floor joist which will split and release the anchor should the floor fall. The wall plate shown in Fig. 15 is

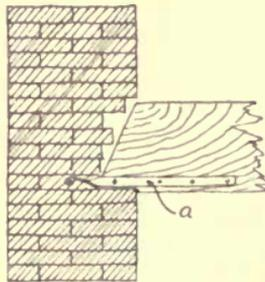

FIG. 14. — STRAP ANCHOR.

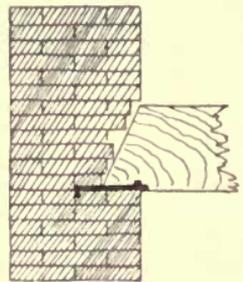

FIG. 15. — PLATE ANCHOR.

an efficient and simple way of anchoring a wall, the timbers easily freeing themselves in case of fire. *Anchor bolts* frequently are run through the building from one side to the other and screwed up on the outside. This gives great strength, but in case of fire, the walls probably will be pulled over, allowing the fire to spread.

12. Openings. — Unless the tops or openings in a brick wall are well arched, or have a stone, metal, or wood *lintel* showing in the face of the wall, they should have a beam of steel, or of thoroughly seasoned wood,

to support the wall above, resting at least 4 inches upon the wall at each side of the opening, and visible only from the back or inside of the wall. A double *rowlock*, or *relieving arch*, should be laid above the beam or lintel, showing upon the inside of the wall, as illustrated in Fig. 16 at *a*, or *b*. An anchor should be placed to resist the thrust of the rowlock arch as shown at *c*.

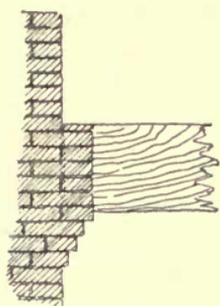

FIG. 17. — COR-BELLING.

13. Corbelling. — *Corbelling* (Fig. 17) gives a better support for timbers to rest upon. This often is made a place of decoration, or part of a cornice, or the base of the spring of an arch.

14. Brick walls. — (A.) Brick walls vary in *thickness* in accordance with the requirements in different cities,

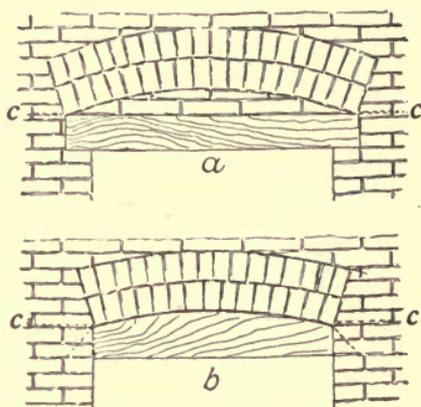

FIG. 16. — LINTELS AND ROWLOCK ARCHES.

but in general the thickness of the first story of the ordinary three-story dwelling is the width of three bricks or 13 inches, and the width of two bricks for the stories above, the foundation walls being from 4 to 8 inches thicker.

(B.) Upon the top of a brick wall, a *wooden plate* should be fastened by means of bolts extending down into the brick wall about three feet, to give a place to which the rafters may be secured, as shown in Fig. 18, and to strengthen the top of the wall.

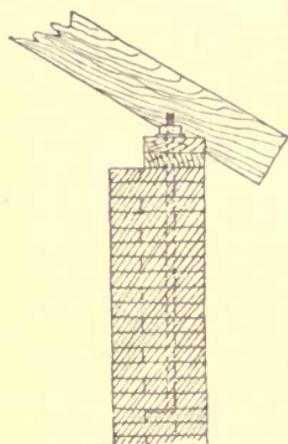

FIG. 18. — WOODEN
PLATE FOR THE TOP
OF A BRICK WALL.

(C.) *Wooden bricks* are pieces of seasoned wood made the size of a brick, but a little larger in the back than in the face, so that they will not pull out easily, and set in the wall at the proper places, to give a nailing for the finish and for the partitions.

(D.) A solid outside wall less than 16 inches thick should never be plastered directly upon the inside, as a long driving rain will soak through. A better way is to fur the inside with 1" strips and to proceed as if upon a stud partition, though the insurance men generally object to this method. In consideration of their opinion, it is a good plan to nail a horizontal piece at the top and the bottom and every few feet between, to prevent the circulation of air, though this to some extent destroys the efficiency of the air space, as ventilation is checked.

A ventilated wall, or a wall so constructed that there are continuous air spaces in it, will prevent the moisture from

coming through; it is warm in winter, cool in summer, and light in weight, but as it is an expensive wall to build properly, it is not used so much as it should be. Painting the outside of a brick wall is a fairly efficient method of preventing the rain from finding its way through, and in case poor bricks are used, as is common in some parts of the country, the wall should be painted. From an artistic standpoint, a painted brick wall is decidedly objectionable, as the texture of the bricks, and their soft color effects, are thereby destroyed.

(E.) If the inside of a building is to be plastered, the brick wall should be laid roughly, and the joints should have no more mortar in them than is necessary to give the wall stability, as the open joints will help the plaster to take firm hold of the bricks.

15. Chimneys. — Chimneys should extend above adjacent ridges to avoid a down draft. One or two bricks should be left out at the bottom of the flue, to allow it to be cleaned easily and the hole should be fitted with an iron cover.

If the chimney is more than three stories high, and if the best results are wanted, its walls should be double thick for a third of its height, as the smoke is kept warmer, thereby assisting the draft. For this reason, a chimney in the center of a house is more apt to draw better than one which is a part of the outside wall. A round chimney usually draws better than a square one. The flues of a chimney should be no larger than necessary, as the smoke cools, thereby decreasing its tendency to rise.

A chimney should not be plastered inside, though it is the custom in some localities. Experience has shown

that the mortar will drop off as the chimney expands and contracts, often taking the pointing from between the bricks with it ; this fact is so well established, that a chimney plastered in this way will be condemned in most large cities.

16. The carpenter and the mason. — In erecting a brick building, the carpenter should have the window and door frames ready to set when the mason is ready for them, and should assist in setting them. He also should see that they are properly stayed, and held in their places until the mason has built around them enough to hold them firmly.

Floor joists, wooden brick, and all other woodwork furnished by the carpenter should be ready to set when the mason is ready for them. Usually it is not the carpenter's place to furnish centers for arches, or to erect scaffolds for masons, though the customs in regard to these points vary in different localities.

SUGGESTIVE EXERCISES

1. What should be considered first in selecting the location of a dwelling? How should the land lie in relation to the house? Should a house be located near a pool of stagnant water? What are the objections to building a house in a deep grove? Are there any objections to a few shade trees?

2. How should the subsoil be investigated? Who usually does this? What mistake is sometimes made in building upon rock? What load will clay support generally? How may a clayey subsoil upon the side of a hill be made safe? What is the best soil upon which to build? Why? What is its resistance? How should sand be treated to prepare it for supporting a building? Compare sand with gravel. Describe piling.

3. With which side of a lot should the front of the house generally

be parallel? How should a house be located upon an irregularly shaped lot? What is the effect upon the property of a neighborhood, if the houses are arranged with no thought of regularity? What is the general shape to be located first in staking out a building? Describe the method of doing this. How can the accuracy of the work be proved?

4. What regulates the size of the excavation at the bottom? Should the sides of the excavation generally be plumb? What should be the relation of the frost line to the footing course?

5. Should a ledge be allowed to extend through the cellar wall? Why? How should a ledge be dealt with?

6. Should the footing course generally be as wide as the foundation? How should a footing course be laid upon a side hill? Should stones rest directly upon each other? Why? Should stone chips be depended upon to make a strong wall? How are cheap foundations laid? Is it a safe plan? How should the footing courses be laid, if a wall rests upon both sand and bedrock? How are the footing courses of heavy buildings sometimes put in?

7. What is meant by rubblework? How should it be bonded? What is meant by ashlar? coursed ashlar? broken ashlar? draft line? pitch, or rock face? How should stratified stones be laid? Why?

8. What is the safest way to insure a dry cellar? What is the least pitch a drain should have? How should the outside of the wall be treated? How should the top of the footing course be treated? If a ledge comes through the cellar floor, how should it be treated? How may a cellar floor be drained after the house is built?

9. Why are bricks better for general building purposes than stone? Compare common and face bricks. What kind of bricks should be used where a great heat is to be resisted? How should a brick be tested? Describe the usual methods of laying brick. What should be the proportions of lime and sand in mixing mortar? Describe grouting. Give the reasons for sorting bricks. How should bricks be treated in dry weather before laying? Is it a good plan to lay brick in very cold weather? How may it be done?

10. What is meant by bonding? What is a header? a stretcher? Describe the English bond; the American bond; a metal bond; a veneered wall.

11. What is meant by anchoring a building? What is meant by a splayed floor timber? Why should an anchor easily detach itself from the wall?

12. How should the tops of openings be treated?

13. What is corbelling?

14. What is the usual thickness of the brick wall of a dwelling house? How should the tops of the walls be treated? Why? Describe a wooden brick. Why not plaster a thin wall directly upon the inside? How should it be done? Describe a ventilated wall. Is it best to paint a brick wall? How should bricks be laid in a wall which is to be plastered?

15. How should the height of a chimney compare with that of adjacent ridges? Should a high chimney be of the same thickness throughout? Why? Which is the better location for a chimney, in the center, or in the outside wall of the house? Should a chimney be plastered on the inside?

16. How should the carpenter assist the mason?

CHAPTER II

FORMS OF CONSTRUCTION

17. **The full frame.** — Fig. 19 illustrates the joint forming the basis of construction of the heavier members of a full frame house (Fig. 20) in which every joint is a mortise and tenon joint, a pin being driven through the hole (*c, d* of Fig. 19), drawing the tenoned timber to its place. Floor joists, studs, tail beams, headers, etc., are mortised and tenoned; in fact, the best work of this form of construction is done without the use of nails, except for rafters and in spiking floor joists and small pieces to their places.

This is the old-fashioned way of framing, and until about 1850 was the method commonly used. A frame of this sort is rarely built now, as the heaviest buildings are of steel, or of the form known as the mill, or slow-burning, construction.

18. **The half frame.** — The *combination*, or *half frame*, a combination of the full and balloon frames, is quite generally used in the best class of dwellings, and other light frame buildings. It follows the full frame as far as the

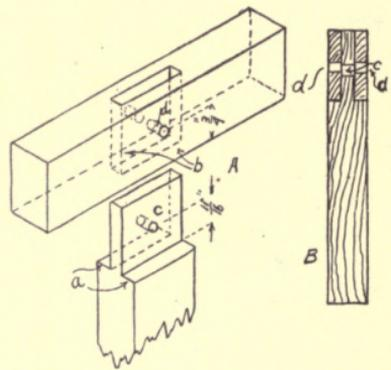

FIG. 19. — MORTISED JOINT, DRAWBORED.

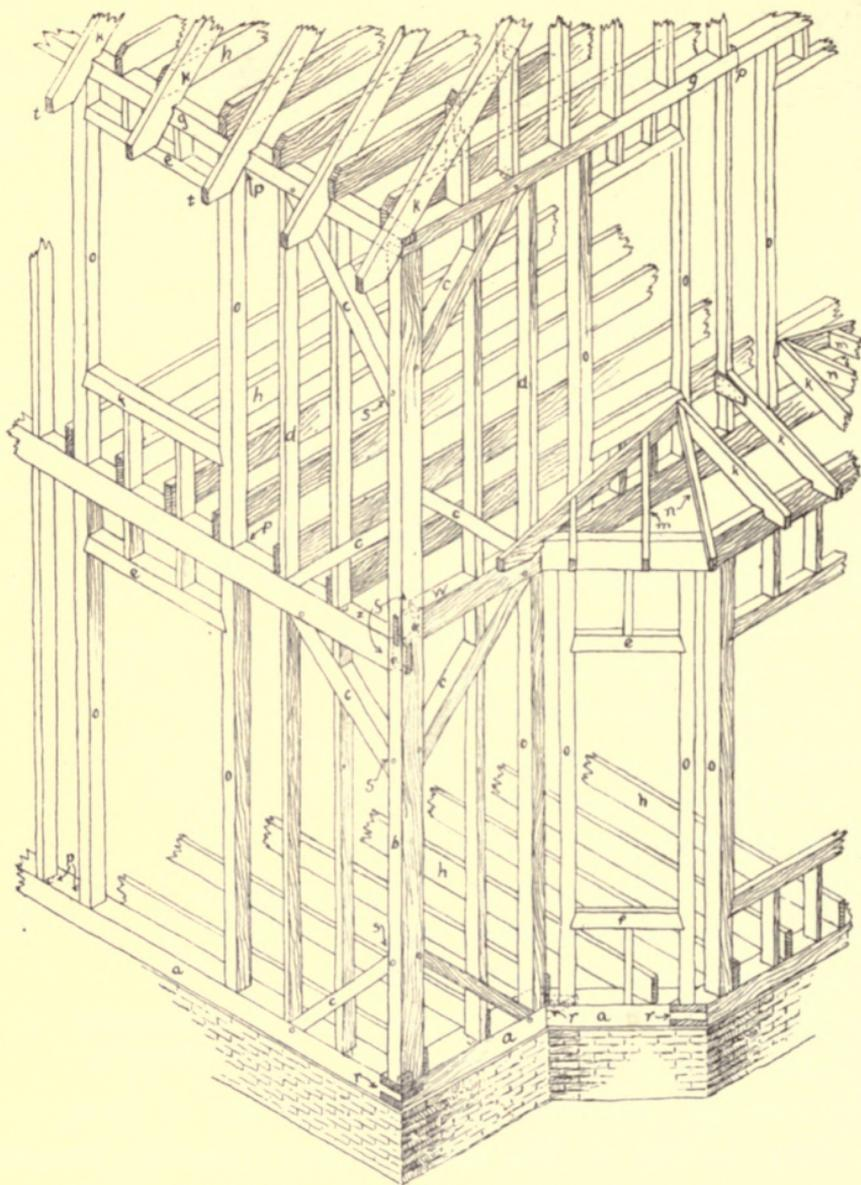

FIG. 20. — FULL FRAME HOUSE.

a, sill; *b*, corner post; *c*, brace; *d*, stud; *e*, head; *f*, stool; *g*, plate; *h*, floor joists; *k*, common rafters; *m*, jack rafters; *n*, hip rafters; *o*, double studs; *p*, mortised joint; *r*, open mortised joint; *s*, mortised joint, drawbored; *t*, end of rafters for box cornice; *w*, raised or flush girts; *z*, sunk or dropped girts.

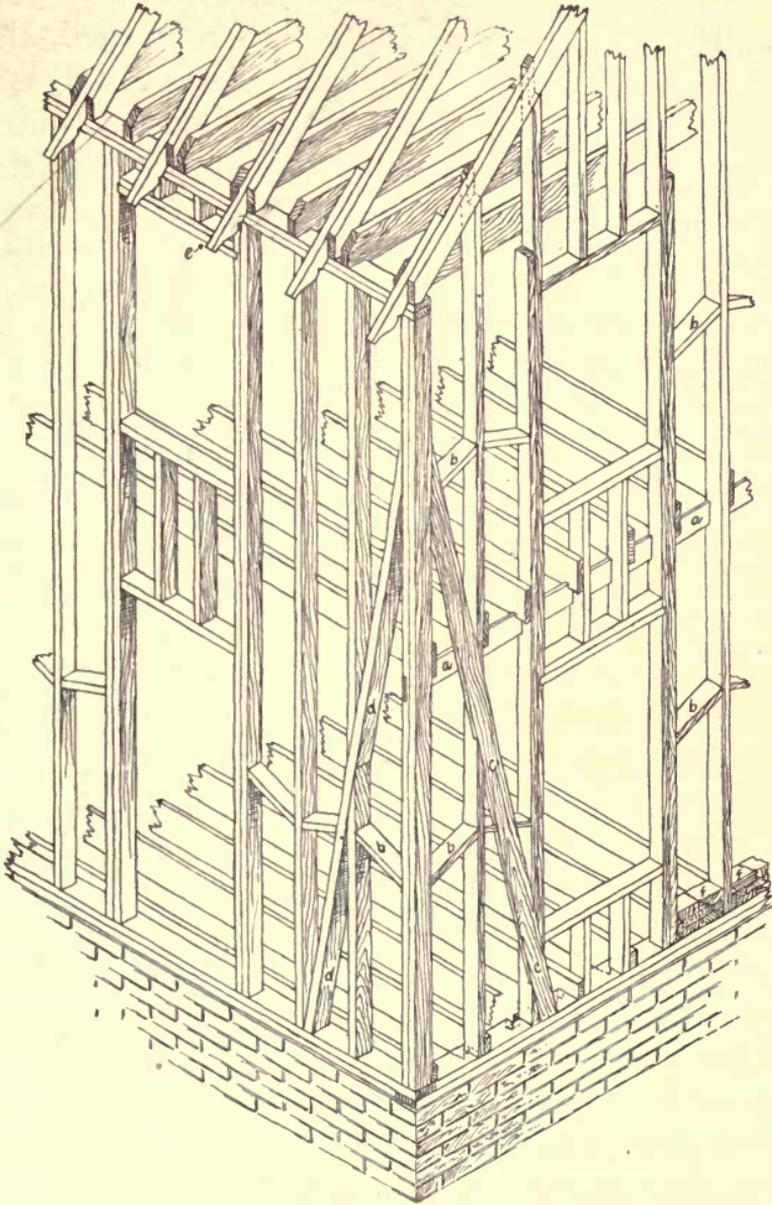

FIG. 21. — BALLOON FRAME.

a, ribband, or ledger; *b*, wall bridging; *c*, 1½" balloon brace; *d*, 2" × 4" balloon brace; *e*, sawed lookouts spiked to the rafter; *f*, brick noggin.

posts, girts, and often the braces are concerned, though the last are frequently of the balloon type, and only spiked. In the best frames of this type, the studs are mortised and tenoned at the top, and nailed at the bottom, though ordinarily they are nailed at both ends.

19. The balloon frame. — The *balloon frame* (Fig. 21) is built by spiking or nailing all timbers together, and is the cheapest form of construction for a frame house. The studs are usually continuous from the sill to the plate, on the sides of the house, except at the openings, and in the gables to the rafters, if pieces of the right length can be secured, otherwise they are usually pieced by means of a fished joint.

The *ribband*, or *ledger board* (*a*), is cut into them to support the floor joists of the second floor.

The *braces* usually extend from the second or third stud on the sill to about 2' 6" from the plate on the corner posts, though they are sometimes not extended above the second floor. Braces are frequently made of 1" or 1 $\frac{1}{8}$ " stock, being let into the studding flush with the outside of the wall, as at *c*. The better method is to use a 2" \times 4", as shown at *d*. It is characteristic of this form of construction to use only the lightest timbers, and, unlike the full and half frames, to build one piece at a time.

A balloon frame is a fire trap unless bridged by pieces of scantling (*b*), which are cut between the studs to prevent the circulation of air, thereby reducing the danger from fire. *Bridging* also makes it difficult for vermin to pass from one story to another, and adds much to the warmth and stiffness of the house. It is a good plan to fill in between the floor joists upon the sills with a brick

nogging (*f*), which assists the fire and vermin-resisting qualities of the building. In the full and combination frames this protection is formed by the solid girts.

A well-built balloon frame is satisfactory for a moderate-sized house, but since it invites poor work and a certain class of builders cannot resist such a temptation, this form of construction has a worse reputation than it deserves. In many cities a balloon frame is not accepted within the fire limits, though a half frame usually will be accepted wherever a wooden building is allowed.

20. Sills. — In framing the sills of a house the corner joints usually are made by being halved together as at *a*,

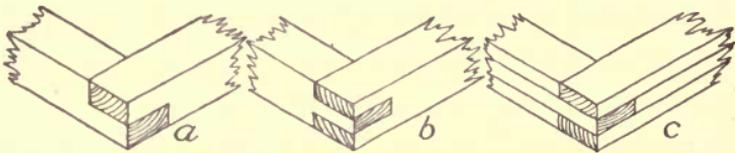

FIG. 22. — FRAMING OF SILLS AT THE CORNERS.

Fig. 22. The sills of a heavy building are frequently fitted together by an open mortised joint, as at *b*, Fig. 22. If the sills are built up and spiked together, they should be crossed at the corners as at *c*, Fig. 22. Large straight timbers are difficult to obtain in long lengths, and are therefore often built up of others of smaller dimensions. Timbers built up in this way have about 75 per cent of the strength of solid timbers of the same size. If the pieces are sprung, or crooked, they often may be straightened by nailing pieces together which are sprung in opposite directions, one piece straightening the other. In a cheap building, the sills sometimes are fitted against each other with a square butt joint, depending upon the boarding and the

finish to hold them together. This is bad construction, and never should be used by a carpenter who values his reputation.

The girders, which extend across the house to support the floor joists and the partitions, are made uniform in size with the sills, and the floor joists are cut to fit them by the same method as at the sills.

21. Corner posts. — The *corner posts* of a full or of a half frame house are framed at the girts by a mortise and tenon joint, the tops of the raised girts being flush with the floor joists, as at *w*, Fig. 20 ; and, in order to prevent cutting away the post too much at one place, and to allow a longer tenon upon each girt, the sunk or dropped girts are placed low enough to allow the floor joists to rest upon their tops, as shown at *z*, in Fig. 20.

The girts sometimes are cut into the corner post with a beveled shoulder, as shown in Fig. 23, to prevent the entire weight of the girt from resting upon the tenon, though this is not usually done upon ordinary work.

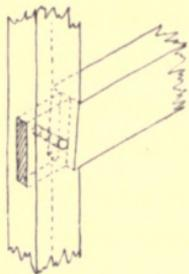

FIG. 23. — BEVELED SHOULDER JOINT.

In a full or a half frame house, the timbers are often weakened by the mortises cut in them, unless stirrup irons are used to support the joists, which would otherwise be tenoned into headers or girts. Other timbers which are usually supported by mortise and tenon joints may be supported in the same way, though a mortise cut in the middle of the depth of a timber affects it less than if cut upon one edge or corner.

The joints between the corner posts and sills of all frame

buildings usually are made as shown in Fig. 24, though frequently they are spiked in the cheaper balloon frames.

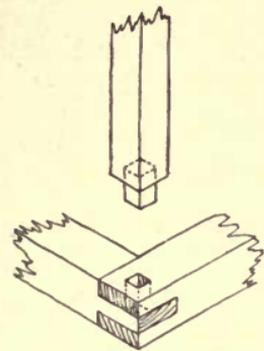

FIG. 24.—JOINT BETWEEN CORNER POST AND SILLS.

Corner posts may be built by one of the methods shown in Fig. 25.

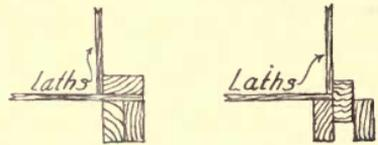

FIG. 25.—BUILT CORNER POSTS.

The ribband

pieces, or ledger boards, which support the floor joists above the first floor, are cut into the studs and corner posts. The depth of the cut is gauged from the outside of the stud, as shown in

Fig. 26, in order that the shoulders or notches of the floor joists may all be cut the same length and that no variation may show upon the outside of the building.

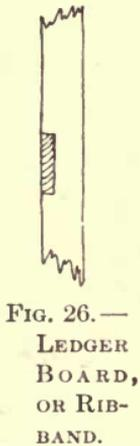

FIG. 26.—LEDGER BOARD, OR RIBBAND.

22. Braces.—In making the cuts, and finding the *lengths of braces* shown in Figs. 20 and 21, the steel square is used. All measurements generally are worked out upon the scale of 1" to 1'. The square most conveniently marked for the use of the framer is divided on the outside into twelfths of an inch. This division may be used easily in working to an inch scale, each inch being read as one foot.

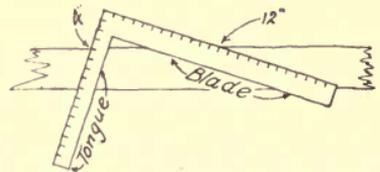

FIG. 27.—POSITION OF THE FRAMING SQUARE IN FINDING THE LENGTH OF A BRACE.

square most conveniently marked for the use of the framer is divided on the outside into twelfths of an inch. This division may be used easily in working to an inch scale, each inch being read as one foot.

In using the steel or framing square, the tongue or short side should be held in the left hand, and the blade or long

side in the right, thereby bringing the square into the position shown in Fig. 27. This brings the 1" scale upon the outer edge.

If the brace is to be of 45 degrees, that is, to extend the same distance on each side of the angle it is to strengthen, say 48", find upon the tongue of the square the figures 48 67.88, the two equal figures giving the distance from the angle, and the other giving the length of the brace, or its hypotenuse. If for any angle other than one of 45 degrees, take the distance from the corner to the brace, say 4', upon

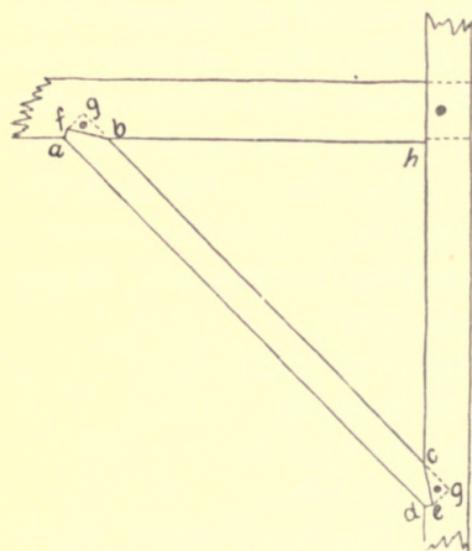

FIG. 28. — BEVELED SHOULDER BRACE JOINT.

the tongue of the square, and the other distance, say 12', upon the blade; as we are working to the inch scale, this means that the measurements to be used are 4" and 12", as in Fig. 27. By marking along the two edges of the square, we have the angles of the cuts, 4" giving the horizontal cut and 12" the vertical. To find the length of the brace, measure across the angle from 4" to 12", the distance given as

inches being read as feet. The accuracy of the result depends entirely upon the accuracy with which the work has been done.

To find *beveled shoulder cuts*, as shown in Fig. 28, find and mark the length and angles of the brace, as if it had

no shoulder, by the method above described, and make the mark upon the brace denoting the length as shown at *ad*. Lay the square with the size of the shoulder, (*de*, or *af*), say 1", upon the tongue, at point *a* or *d*, and bring the square around until the blade coincides with point *b* or *c*. Connect *e* with *d* and with *c*; *f* with *a* and with *b*. These lines denote the cuts of the shoulders at each end. The entire length of the brace, including the tenons, should be from *f* to *e*. The ends of the tenons, (*g, g*), will allow sufficient wood for drawboring. Upon common work, the joints of the brace usually are cut to the lines *ab* and *cd*, and the joint firmly spiked.

To cut the post, and the sill plate, or girt for the brace, or the horizontal and vertical members to be braced, measure from the corner *h*, to points *a* and *d*, and from them mark points *b, c*, and lay off lines *af, fb, de*, and *ce*, by the same method used in obtaining the corresponding lines upon the ends of the brace. The length of the brace is always between the points *a* and *d*.

23. Floor joists. — The methods of resting the floor joists upon the sills and girders are shown in Fig. 29: *a* is the method frequently used upon cheap buildings; *b*, upon the best class of buildings; and *c* illustrates a

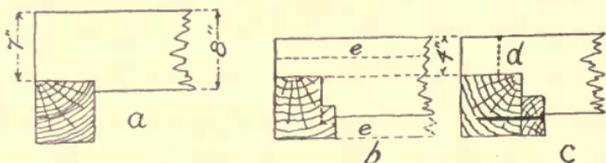

FIG. 29. — SIZING FLOOR JOISTS, TO FIT SILLS AND GIRTERS.

method sometimes used where it is necessary to avoid the height above the sill at *a*, and where it is not desirable to take the time to cut mortises. The joists need be no longer than to reach the stud, as at *d*, though if they extend to the

outside of the stud, they may be spiked to the side of each stud they come against, thus giving additional strength.

As there is so much difference in the size of timbers, it is necessary, in order to make the floor joists line up straight on top, always to size the floor joists to 1" narrower than the timber, as shown in Fig. 29. This sizing should be done from the top edge of the joist, which in every case should be the crowning or rounding edge, so that when the floor is loaded, the deflection will tend to straighten the joists.

A floor joist should be nailed against the outside wall, to give a nailing for the floor boards and the ceiling laths.

Two floor joists, with a 2" space between them, should be placed under the partitions, or a double floor joist may be used instead, if a piece of 1" \times 3" is nailed to each side of it, to give a nailing for the flooring and the ceiling laths.

Floor joists in almost every case should be placed 16" to centers. As laths are cut 48" long, this distance gives four nailings to each lath and makes cutting unnecessary. If the space to be filled is not a multiple of 16", the variation should all come at one side of the room, so that the laths will not have to be cut more than necessary. In heavy work the floor joists are often placed 12" to centers. If floor beams are used as trimmers, to carry the header of a flight of stairs, they should be doubled, unless otherwise supported. Headers and trimmers carrying but one or two tail beams will do if a single thickness is used.

If a floor joist is sprung sideways, it must be held straight by "battens" or *bridging* until the flooring is nailed, or there will be enough deflection when the weight is placed upon it to crack the plastering of the ceiling below.

Floor joists over 12' in length should have, in the center, a row of bridging (see Fig. 30), which imparts sufficient stiffness to require three times the load to cause the same deflection as without, and which insures that the joists will never buckle. Rows of bridging should not be more than 8' apart; for a small house 1" \times 3" material will generally answer, but for a large building, nothing less than a 2" \times 3" should be used. To make bridging, it is the usual custom to saw one end of a long piece at the correct angle, and place it as shown at *a*, or the height of the beveled end above the bottom edge of the floor joist.

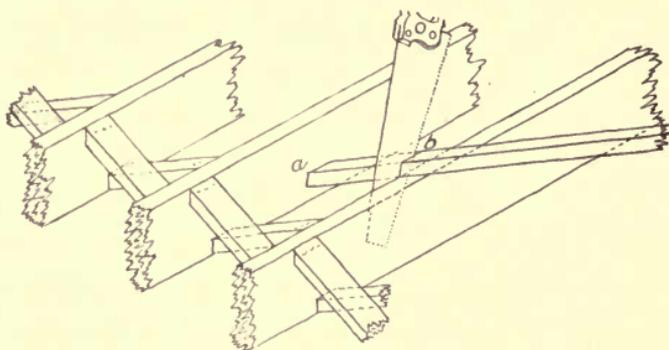

FIG. 30. — BRIDGING.

With a cutting-off saw, cut the other end of the bridging, carrying the saw by the side of the floor joist as at *b*. This cuts the piece to the desired length and angle without any further measuring, or the use of any other tool, and at the same time gives the angle for the lower end of the next piece. Some workmen have a miter box with a bridging cut made in it, and saw the bridging for an entire floor before nailing. The uneven spaces will have to be cut separately.

24. Studding. — The studs of a house are generally spaced 16" between centers, in order to accommodate the laths, which are 4' long. It is always best to use stuff which has been run through a planer and sized down to an

even width, as time will be saved in straightening up the partition, and a much better job of plastering can be made than if it depended upon the plasterer to make a straight wall.

The best constructive practice is to bring the partitions directly over one another as much as possible, as in Fig. 31, supporting the upper by the lower, with a scantling plate between the two to prevent the passage of fire and vermin,

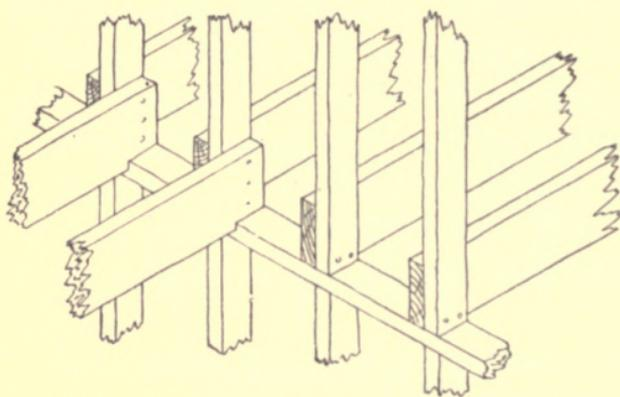

FIG. 31. — PARTITIONS.

and to support the floor joists. This method of putting in the partitions minimizes the danger of plaster cracks in the corners, as the partitions of both floors are supported by the girt of the lower floor, thus making the shrinkage of the house practically the same in the partitions and outside walls. If a house is built by laying a floor and constructing the partitions upon it, there will always be cracks in the plastering, as soon as the building seasons. This method has nothing to recommend it but its inexpensiveness, and is used only upon the cheapest class of houses, except as it is the method by which a closet or other unimportant partition is built.

In setting a partition, care must be used that the studs are set upon a straight line, with straight, double studs at the openings and angles. If a stud is so crooked that the

laths and plaster will not cover the defect, say, over $\frac{1}{4}$ " in the height of the partition, straighten it by making a saw cut in the the concave edge, and driving in a wedge as shown in Fig. 32. Nail a fishplate upon one side of the stud to give stiffness as indicated. A scantling which is badly sprung should be cut for headers and other short pieces, unless it is to be used in a place where it can be spiked straight.

Partitions should be bridged as at *b*, Fig. 21, for the reasons discussed in Topic 19. This is rarely done upon cheap balloon buildings, and it is this, more than anything else, which has won for this type of building the name of "fire trap." Unless necessary for stiffening, this bridging is often omitted in building a full or half frame house, as the solid girts close the fluelike spaces between the studs.

25. Porch construction. — The *floor joists* of a porch should run parallel with the house (see Fig. 33), as the floor boards should be laid square with the front, and should pitch 1" in 5' in order to allow water to run off easily.

Porch floor boards should be not over 4" wide, and should be laid open about $\frac{1}{8}$ " to assist in ventilating underneath the porch. This is not always done. Laying a porch floor in this way has its disadvantages and, if the porch is well ventilated otherwise, it will be unnecessary. A tight-jointed porch floor should be laid of well-seasoned matched boards, and the joints well leaded before laying.

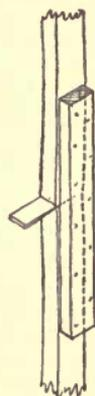

FIG. 32. — STRAIGHTENING A CROOKED STUD.

It is a good plan to leave the porch open underneath, but if it is to be boxed up, lattice work should be used or open-jointed boards laid in order to allow a free circulation of air, the most effective preventive of decay.

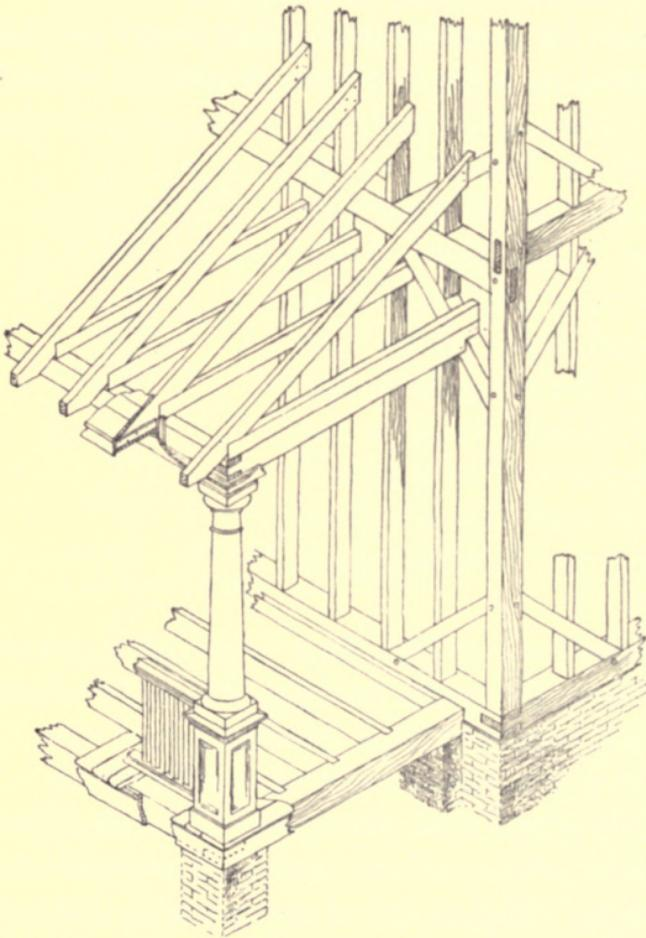

FIG. 33. — PORCH CONSTRUCTION.

In general the porch floor should be one step lower than the floor of the house, especially in northern climates, as it will, to a great extent, prevent snow from driving under the door, or piling up against it. This also gives more height to the porch, or more pitch to the roof, which is apt to have less pitch than it requires, its rise being limited by the second story windows.

The *foundation* of a porch is liable

to be neglected, as it is generally a light structure; but a careful builder will see that it is well supported below the frost line.

The porch roof and floor should be fastened to the building by some method similar to that illustrated in Fig. 33.

The *height* of a porch ceiling ordinarily should not be less than 8'. If it is too low, the roof excludes light from the house; if too high at the eaves, the roof may have insufficient pitch to allow the water to run off freely.

The required details of the cornice and frieze of a porch govern the construction above the columns and at the eaves, but the illustration indicates a common method of constructing a box-finished porch roof.

A *metal roof* should be used if the pitch is less than 5" to a run of 12'. If a flat metal roof is to be walked upon, it should be protected by a movable wooden floor.

As the porch usually is the entrance to a house, and a prominent feature, it is more or less embellished. There are many different designs for the details, but where *straight rails* are used, the work is practically the same. There should always be a *wash* pitched about 1" in 7" upon the top and bottom rails. The top of the top rail may be about 30" from the floor, but it often is not more than 26". The bottom rails should be placed about 3" above the porch floor, so that water may run under them easily, and sufficient room be left for sweeping.

If a *ramped rail* is used (see Fig. 34), the joint between *a* and *b* should be made very strong; rail bolts (*c*) and dowels (*d*) should be used to insure rigidity. The ramp (*a*) is made usually of one piece, worked by machine to the same

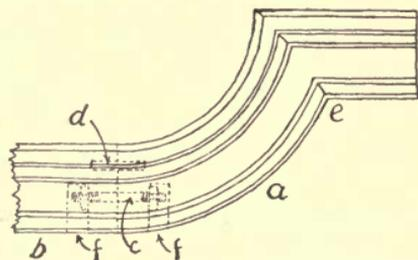

FIG. 34. — RAMPED RAIL.

molding as the rail. The holes (*f*) should be plugged up after the rail is together. All joints should be fitted carefully, and well doped with white lead.

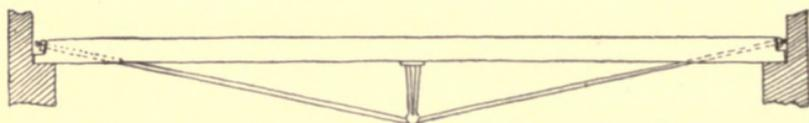

FIG. 35. — TRUSSED GIRDER.

26. Trusses. — It is not within the province of this book to discuss the stresses which a *truss* is called upon to resist, or to enter upon the engineering problems which are neces-

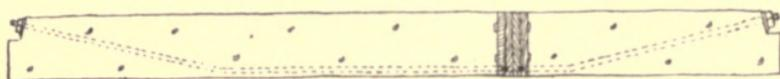

FIG. 36. — GIRDER STIFFENED BY RODS.

sary to be solved in order properly to design a truss; we will, however, endeavor to say something of the different forms of trusses with which the carpenter has to deal in the

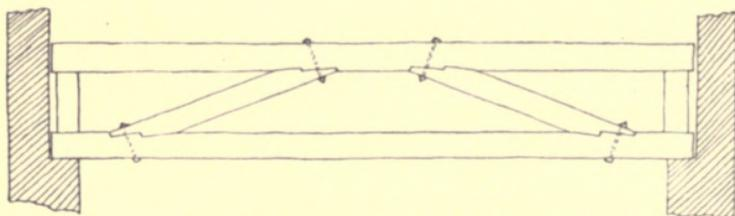

FIG. 37. — BUILT TRUSSED GIRDER.

ordinary course of his work, and the details of their construction.

(A.) A *trussed girder*, or *belly rod truss* (Fig. 35), is an efficient method of strengthening beams and girders. Fitting the rod in the depth of the beam, as in Fig. 36, does not add a great deal to its strength, because if loaded to its

limit, the beam will generally fail on the upper edge first, the fibers crushing by compression, before the bottom fibers break under the tensile strain.

(B.) A satisfactory form of trussed girder is shown in Fig. 37, which may be used in places where it is desirable that as little vertical space be occupied as possible.

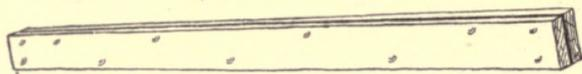

FIG. 38. — FLITCH PLATE GIRDER.

(C.) A *flitch plate girder* (Fig. 38) is sometimes used where it is desirable that the girder shall be contained in the thickness of the floor. This consists of iron plates bolted

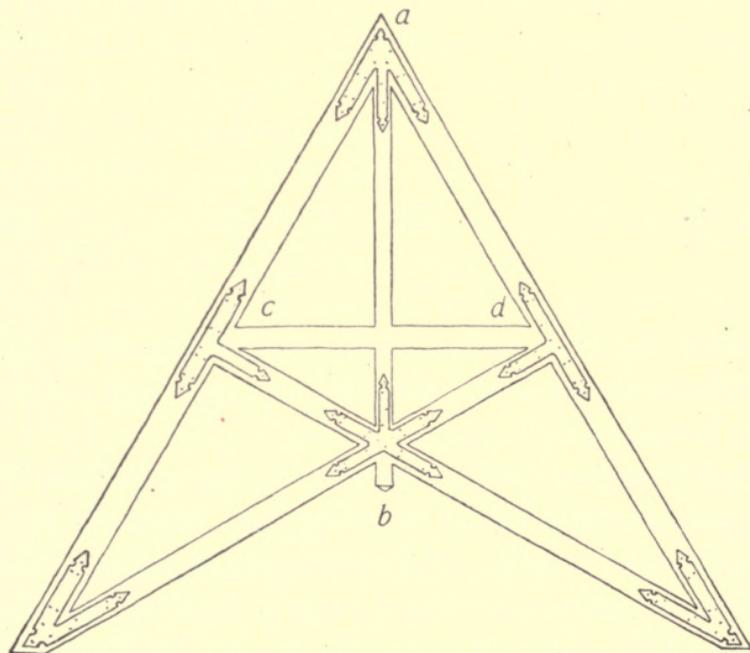

FIG. 39. — SCISSORS TRUSS.

between floor joists. An iron I beam when available is used generally for this purpose.

(D.) The *scissors truss* (Fig. 39) is used a great deal in the

construction of churches and other buildings where it is necessary to obtain all the height possible at the center. The *kingpost* (*ab*) and the *tie beam* (*cd*) should be very carefully planned, as these members are depended upon to hold the truss in shape, and to prevent the building from spreading at the eaves. This truss may be built of small timbers; if the maximum of strength is desired, an iron plate should be made to extend for a sufficient distance at each side of all the joints and should be securely bolted in place there.

(E.) The *Howe truss* (Fig. 40) is the form generally used

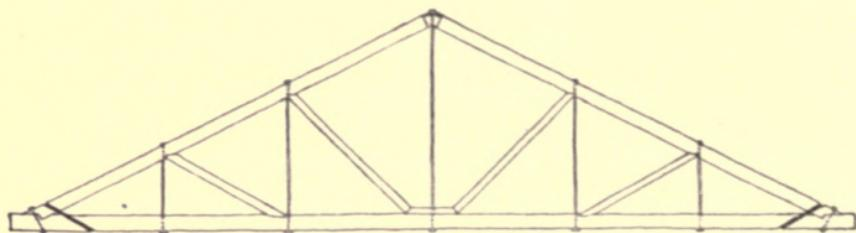

FIG. 40. — HOWE TRUSS.

in constructing the roofs of large buildings where there is no middle support, as a truss of this type may be made to support a roof of any pitch.

It is in accordance with the best modern practice to build important trusses of steel, as they may be made lighter in appearance and weight. The strength of a steel truss may be estimated more accurately than that of one built of wood, and but slight variation is caused by shrinking.

The above forms of trusses are capable of variation in design, but the simple trusses built by the carpenter are usually based upon one of these. Unless the builder has the training to design an economical and efficient truss, he

should not attempt to design one by guesswork, but should engage the services of an engineer.

27. Timbers. — The sizes of timbers are governed by the needs of the building. The *sills* of a moderate-sized dwelling should be 4'' × 6'', 6'' × 6'', or 6'' × 8''. The plates should be 4'' × 4'' or 4'' × 6'', or the same size one way as the width of the studs.

The *studs* should be 2'' × 4'' for the main partitions and the outside walls, while for cross and minor partitions 2'' × 3'' studding is sufficient.

Stair strings or *carriages* should be 2'' × 10''. For lower floor *joists* from 12' to 14' long, with one row of bridging, material 2'' × 10'' should be used, though for a light framed house, 2'' × 8'', if well bridged, is generally sufficient. For spans of over 14', 2'' × 12'' should be used.

Second floor joists should be 2'' × 8'' or 2'' × 10'', though the former, with bridging, is generally used in light buildings and for short spans.

Rafters, not over 14' long, if well supported by purlins and collar beams, will be satisfactory if made of 2'' × 4'' material. Rafters longer than 14' should be made of 2'' × 5'' or 2'' × 6'', unless very well supported.

It is not a good plan to make a roof heavier than it need be, as unnecessary weight adds to the difficulty of keeping the building in shape. Unless the plates are well tied, the house is apt to spread at the eaves, causing great difficulty if there is a room in the attic.

Collar beams over 8' long should be made of 2'' × 6'', though for a light framed house 1'' × 6'' is often used.

28. Selection of timbers. — The selection of timbers is a matter of great importance in the building of a house.

None should be used which show any signs of decay, or which have a sour or musty smell, as they will in time, unless in a well-ventilated place, affect all wood with which they come in contact.

There should be no large knots nor other defects which weaken the timber to an appreciable extent, and timbers which have the heart in them should not be depended upon to resist heavy strains. This rule generally is followed more closely in small timbers than in those of large dimensions, as it is difficult to obtain timbers of large sizes without heart.

SUGGESTIVE EXERCISES

17. Describe the principal features of a full frame.
18. Describe a half or combination frame.
19. Describe a balloon frame. Compare the three types of frames, and the work upon which they are generally used. What is the chief objection to the balloon frame in a crowded locality?
20. Describe built-up timbers. Compare the efficiency of built and solid timbers.
21. Describe the method of framing the girts into corner posts. What is the objection to cutting mortises into timbers? In which part of the timber does the mortise do the least damage? In what respect is a balloon frame superior to other forms? Describe the joints between the corner posts and sills of full, half, and balloon framed buildings. How are ledger boards cut in? From which side of the studs should the depth of the cut be gauged? Why should the ledger be parallel with the outside of the wall?
22. Describe the use of the steel square in framing a brace. Demonstrate the marking of a shoulder, and the length of a brace. Demonstrate the method of marking the brace cuts in the corner posts and sills, plates, or girts. Between what points is the length of a brace?
23. Describe the sizing of a floor joist. Why is it necessary? How are floor joists placed if they support a partition? How is a nailing for the floor boards and ceiling laths secured? What is the usual distance

between the centers of floor joists? How should floor beams which carry headers be treated? What are floor beams called which extend from a header to the wall? How should a floor beam which is sprung sideways be straightened? What is the advantage of bridging?

24. What is the usual distance between the centers of studding? Why? How should studs at angles and openings be set? How should studding be treated before it is taken to the building? Why? How can a stud in the partition be straightened? Where should the crookedest pieces be used? What should be done to the studding of a balloon framed house to prevent continuous air spaces? What other purposes would this serve?

25. How should the floor joists of a porch run? Should a porch floor be laid perfectly level? Why? Describe and compare methods of laying porch floors. Should a porch be boarded up tightly underneath the floor? Why? Should the porch floor be level with the floor of the house? Why? Describe the method of fastening a porch to the house. What should be the height of a porch? Why not more nor less? What should be the height of a veranda rail? What is the least rise upon which anything but a metal roof should be used? How should a metal roof be protected?

26. Describe a belly rod truss. What is the value of a belly rod fitted in the depth of the girder? Upon which edge does a timber fail first? Describe a simple form of trussed girder. Describe a fitch plate girder. Describe a scissors truss, and its advantages. Describe the form and uses of a Howe truss. Why is steel construction supplanting wood for heavy work?

27. How large should the sills for a moderate-sized dwelling be? the plates? the studs? the stair strings? the floor joists? the rafters? the collar beams?

28. What imperfections in timber should cause it to be rejected? What imperfections usually have to be permitted in large timbers? Why?

CHAPTER III

MILL CONSTRUCTION

29. Introduction. — The type of building known as the *slow-burning*, or *mill construction*, recommended by the Associated Factory Mutual Fire Insurance Companies of Boston, Massachusetts, is used extensively for the construction of buildings for manufacturing purposes. Wherever reasonable safety from fire is desired at minimum cost, this form of construction is considered the best.

(A.) It is a well-established fact, that *cast-iron* or *steel construction*, unless thoroughly protected by a fireproof casing, will collapse in time of fire sooner than heavy timbers, as the heat so softens the metal that it will not sustain its own weight, while a heavy timber, perhaps, would not weaken enough to fail before the fire is under control.

It is not claimed that this form of construction is fireproof; but it is claimed that it does not burn readily, that on account of its peculiarities every opportunity for fire-fighting is given and that a fire, which in an ordinary building might be disastrous, would in one of this type do comparatively little damage.

(B.) Prior to the origin of this form of construction, insurance companies refused to insure, except at prohibitive rates, factories making certain lines of goods; but upon the introduction of this building type by Mr. Edward Atkin-

son of Boston, to whose courtesy is due the material for this chapter, it became possible for these buildings to be insured if properly constructed. This type of building is rapidly replacing all others; especially is this true of cotton factories, of which a great many have been built in the Northern States, and through the cotton belt of the South.

(C.) Slow-burning construction is used in building moderate-priced factories, warehouses, business blocks, and

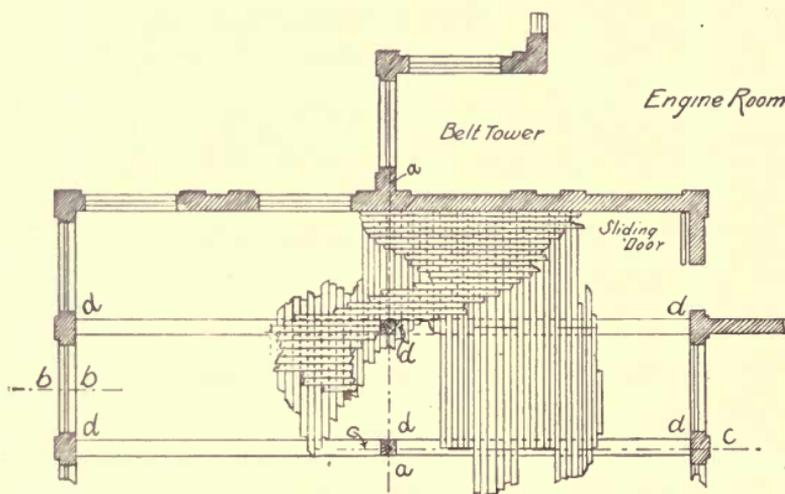

FIG. 41. — FLOOR PLAN OF A SECTION OF A MILL, SHOWING TWO BAYS.

dwelling houses because of its simplicity, strength, and the rapidity with which it may be erected, and also because of its adaptability to very fine architecture if the designer uses judgment and skill.

30. **Details.** — (A.) The details of this form of construction are shown by the three accompanying illustrations. Fig. 41 shows the floor plan of one end of a small factory building, and the horizontal section of the walls and the

posts. It will be seen that the building can be made of any width or length, and that the posts should be arranged in regular rows, or bays, which may be of any size from 7' to 10' to accommodate the building for which they are intended. The bays are generally planned to be between 7' and 9', so that either 14', 16', or 18' lumber may be used

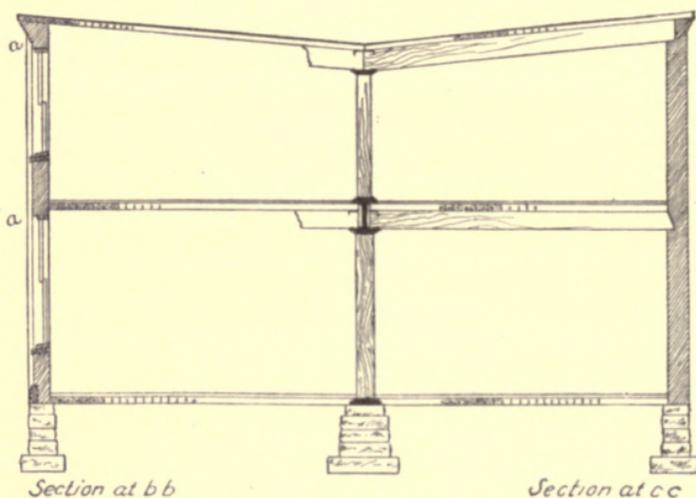

FIG. 42. — CROSS SECTION OF ABOVE MILL.

for the under flooring, in this way allowing each piece to land upon three floor timbers.

Fig. 42, *a*, shows the *cross section* of Fig. 41 at *bb*, in which it will be seen that the windows extend above the line upon the wall upon which the floor timbers rest; *cc* shows the corresponding section of Fig. 41. A pitch in the roof toward the center of the building allows the water to be conducted economically to cisterns, and will, in most localities, furnish a valuable supply of soft water. In case of fire the walls are less liable to be pushed over by the falling in of the roof.

Fig. 43 shows the *longitudinal section* of Fig. 41 at *a a*. It will be noticed that there are no girders, as the heavy floor plank make them superfluous. The brick work should be corbelled out at *a a*, to support a piece of 6" \times 6" which will furnish a nailing for the ends of the heavy floor timbers. This piece should be anchored to the wall.

From the above illustrations it will be seen that the posts extend continuously from the foundation to the roof, the floor timbers resting on caps upon the tops of the posts, and the posts above upon the pintles (*c*) and the bases (*d*), as shown in Fig. 44, the timbers being anchored to the walls and posts as shown at *a* and *b*. Thus the entire building is supported at certain points directly upon the foundation, which therefore does not have to be continuous.

(B.) In the old form of construction, the floor joists were placed 12" or 16" on centers, making it necessary that the walls and foundations should be of equal strength throughout their length, while in the type of building we are discussing, the weight is carried at the places where the large floor beams rest upon the walls, as at *d*, Fig. 41. This allows the walls to be built with *pilasters*, strong enough to support the weight, and the spaces between to be filled with brick, or with a metal panel or curtain, which need not be of the same thickness as the pilaster, as it has only its own weight to support. The arrangement

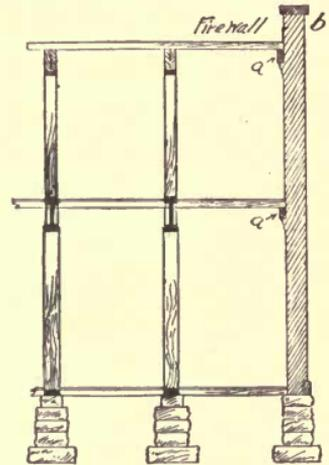

Section *aa* of Fig 41

FIG. 43. — LONGITUDINAL SECTION OF ABOVE MILL.

bers are large enough to support the load safely after a third of their strength has been burned away.

Posts should not be painted nor in any way kept from the air until they have been thoroughly seasoned, — which may take two or three years from the time the timber was cut, — or dry rot may result.

To obtain the best results, an $1\frac{1}{2}$ " hole should be bored lengthwise of the column, with a $\frac{1}{2}$ " venthole at the top and bottom; this will help to prevent checking, as well as to assist the column in drying out more rapidly.

(D.) The heavy *under floor* which is laid upon the floor timbers should be at least 4" thick and bear upon three of them; the joints should be broken every few planks.

This under floor generally should be tongued and grooved or keyed together, as at *e*, Fig. 44, upon the top of which are sometimes laid 2" strips, the space between being filled with mortar for giving additional security from fire above, and also for deadening, as sound travels easily in buildings of this type, unless some preventive is used.

Upon the 4" under floor is laid a *wearing floor*, as at *f*, Fig. 44, or, if the 2" strips are laid as above described, the wearing floor is laid upon them.

This floor may be of any kind of wood, generally oak or maple, at least $1\frac{1}{4}$ " thick, matched, though $\frac{7}{8}$ " flooring is sometimes used. The wearing floor usually is laid at right angles with the under floor but, if placed directly upon it, is laid diagonally. Though this is more expensive, it often is preferred, as a better brace is secured, but in no case should the two floors be parallel, as any unevenness, or shrinking will affect them.

(E.) One important feature, and a great advantage of

this type of building, is that about one half of the wall space may be of glass, a factor of great value for manufacturing purposes.

The *windows* usually are extended as high as possible, as at *a*, Fig. 42, not only for light, but for ventilation, and may in most cases be placed directly under the floor above, between the floor timbers.

This is a great improvement over the old form of construction, in which the tops of the windows had to be kept down to allow the floor joists to rest upon the wall above them. Mill construction allows the tops of the windows to be about 2' higher than those of other buildings of the same size.

(F.) Fire should be retarded in its passage from room to room by *tin-covered wooden doors*, — sheet metal doors will warp badly in case of fire, — and by partitions of solid wood, which should never be less than 3" in thickness. Brick partitions, or fire walls, should extend above the roof as at *b*, Fig. 43.

(G.) No holes should be cut through the floors; the stairways, elevators, lavatories, and other closets should be in a part of the building separated from the rest by means of brick walls and fireproof doors.

There should be neither inclosed corners nor continuous air spaces to allow fire to be carried from one part of the building to another, and the rooms should be so planned that a stream of water may be thrown into any part of them.

(H.) *Belt holes* should be avoided as much as possible; the main belts may be carried from the engine room to the main shafts in a brick belt tower, as in Fig. 41, the hole in the wall through which the shaft passes being the only hole

opening into the main building. In this way a fire may be confined in one place and kept away from the engine room.

In the most up-to-date manufactories, the power is transmitted by electricity. If the wires are properly installed, this is the ideal way, since there is at least a separate motor for each main shaft or one for each machine.

NOTE.—A number of different forms of fire-fighting apparatus, adapted to the protection of these buildings and their contents, have been invented, and an up-to-date building of this sort should be thoroughly equipped with them, but as they are not within the province of this book, they will not be described here. Information regarding them, and a more complete description of mill construction may be obtained from the Inspection Department of the Associated Factory Mutual Fire Insurance Companies, 31 Milk Street, Boston, Mass.

SUGGESTIVE EXERCISES

29. Compare the effect of fire upon unprotected iron or steel, and upon heavy timbers. What is claimed for Mill construction in regard to its fire-resisting qualities? What were the conditions which led to the invention of this form of construction? For what kinds of buildings is Mill construction used?

30. Describe the chief characteristics of this type of building. What conditions govern the size of the bays? In what way is it possible to save expense in laying the foundation of a building of this sort, as compared with that of an ordinary building? Compare the walls of a building of this type and those of the ordinary type. What is the smallest size of timber which should be used in this sort of building? Which is the stronger, an 8" × 8" timber, or a 4" × 14" set edgeways? Should the floor timbers of this type of building be of a size simply to support the weight in safety? Why? Should green posts be painted? Why? How long should they be allowed to dry out? Describe the purpose of boring a hole lengthwise of the column. How should the heavy flooring be laid? How thick should a floor of this sort be? How is a floor sometimes deadened? What should be the thickness of the wearing floor? How is the top floor generally laid in relation to the

under floor? How may it be laid to strengthen the building? Why should it not be laid parallel with the under floor? Compare the possible light area of Mill construction with that of the ordinary building. Why is this possible? What sort of door should be used in Mill construction? Why is a sheet metal door less serviceable? Where should the elevators, lavatories, etc., be placed? What was said of inclosed corners and continuous air spaces? Why? How should the main belts be carried from the engine room? What is the object of this? What is the best method of transmitting power?

CHAPTER IV

THE CARPENTER'S STEEL SQUARE. CARPENTER'S GEOMETRY

31. **Steel square.** — (A.) The *blade* of the standard steel square (Fig. 45) is 24'' long, 2'' wide; the *tongue* is 14'', 16'', or 18'' long and 1½'' wide. The widths are so made for the sake of quick and convenient measure: the blade width corresponding to the thickness of most material used in framing an ordinary building, such as rafters, studing, etc., the tongue width corresponding to the size of the common mortise.

The edges of the back side of the square are divided into 16ths of an inch upon the outside, and 8ths or 4ths upon the inside. The face side of the square is divided into 12ths of an inch upon the outside edge, and 8ths or 4ths upon the inside.

(B.) For our purposes we will consider the side of the square which is used the most by the framer as the *face side*. In holding the square, take the tongue in the left hand, and the blade in the right, bringing the face of the square uppermost. In this way it is used in doing ordinary work, as the 12ths of an inch upon the outside edge divide each inch into one foot, making a 1'' scale. Thus the blade, if used as a scale, is 24' long, and the tongue 14', 16', or 18' long.

(C.) Upon the face of the square, as at *a*, Fig. 45, is the *board measure*, the use of which is very simple and often

a great convenience. The figures denoting the width of the board will be found under the figure 12 upon the outside edge, as at *b*. Having found the width, say

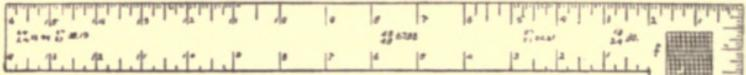

FIG. 45. — THE CARPENTER'S STEEL SQUARE.

10'', follow the line upon which it is located to the figures of the inch division which denotes the length, say 16', as at *c*; upon the same line as that upon which the 10'' is located the figure 13.4 will be found, which represents the surface measure of a board of the above dimensions.

This method is not generally used by carpenters, but accuracy may be obtained in this way without estimating.

If a very wide board is to be surveyed, say 22'' wide and 16' long, the area may be found by doubling the result of 11'' and 16', or 29.4 square feet.¹

A rafter measure is sometimes placed on a square instead of the board measure. As this is read by a very simple principle, it will not be discussed here.

(D.) The *brace measure* is found upon the face side of the tongue of the square, and is read by looking for the figures which denote the distance from the corner of the angle to be braced, to the point of intersection of the brace and the two

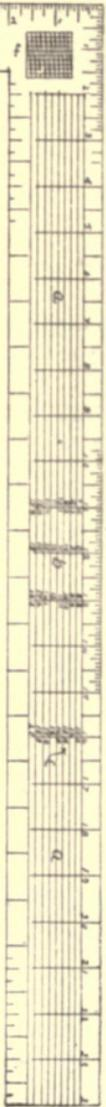

¹ Topic 12, of "Elements of Woodwork" describes and illustrates the use of the lumber scale, which is similar to the board scale, as the same principle applies in the use of each.

sides of the angle, if the angle is a right angle. The use of the brace measure is explained in Chapter II, Topic 22.

(E.) The diagonal scale of 100ths of an inch (Fig. 46) is used when it is necessary to work to 10ths or 100ths of an inch. It is found generally upon the face of the square near the angle, as at *f*, Fig. 45, though an inch divided into 100ths is often used instead. Many squares do not have either scale, as it is rarely used by the carpenter, because the fractions to which he works are based upon 16ths of an inch. The principle of the diagonal square is not hard to understand, as it is a square inch divided into 100 squares.

A line connecting *a* with *b* divides each line through which it passes into tenths; thus, if 1.57'' were desired, the distance from *x* to *y* would give it more easily than if the measurement were taken from an inch divided into 100ths, where the divisions are so small that they are difficult to read.

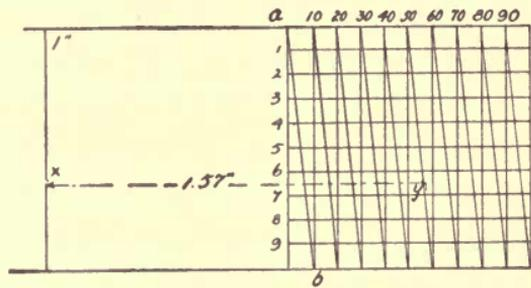

FIG. 46.—DIAGONAL SCALE OF 100THS OF AN INCH.

32. **Bevel board.** — In working out steel square problems, use a planed board, 12'' or 15'' wide, and about 3' long, which we will call a *bevel board*.

One edge of this board should be jointed perfectly straight and square. In marking, a knife or a very hard, sharp pencil should be used, and the greatest accuracy should be continually exercised. As the workman acquires experience, he will be able to dispense almost

entirely with this board, laying out his work directly upon the material.

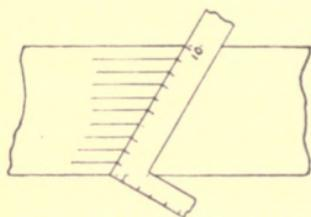

FIG. 47. — DIVIDING A BOARD INTO EQUAL SPACES.

33. To mark divisions. — Lay the square upon the board, as shown in Fig. 47. To divide the board into any number of equal parts, say 10, mark the inch divisions upon the board. By this method a board may be divided, using any convenient divisions upon the square. A rule may be used in the same way.

34. To lay out regular polygons with a steel square. — (A.) *Any regular polygon*, or any polygon of equal sides and angles, may be inscribed within a circle. Each side of such a polygon forms the base of an imaginary triangle, the apex of which is the center, or axis of the polygon, and the sides of which form the miter of the polygon. See the construction of a hexagon, Fig. 50.

Thus each of the five triangles, which constitute a five-sided polygon or pentagon, will have $\frac{360^\circ}{5} = 72^\circ$ in its vertex angle.

The angles formed by the base of each triangle, or side of the pentagon with the sides of its triangle, may be found by dividing the vertex angle by two, and subtracting the quotient from 90° ; in the case of a pentagon, this angle would be, $90^\circ - \frac{72^\circ}{2} = 54^\circ$.

In using a steel square, to lay out a *right angle triangle*, the student should remember that the sum of the two angles with the hypotenuse is always 90° , or the angle of a

perfect square, because this is the mathematical basis of nearly all of the work which can be done with the steel square. Thus, if one angle of a right-angled triangle is 40° with its hypotenuse, the other angle will be 50° , and if the blade of the square is at an angle of 30° with the diameter of the semicircle in Fig. 48, the tongue will be at an angle of 60° . If pins were driven at a and b , and the square rotated against them, the angle c would describe the arc of a circle.

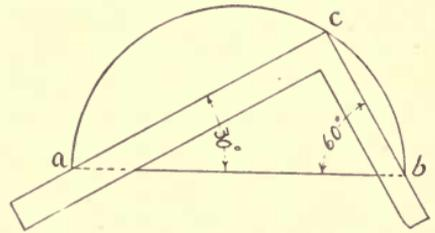

FIG. 48. — CONSTRUCTION OF A CIRCLE WITH A STEEL SQUARE.

NOTE.— Hereafter “the tongue” or “on the tongue” will be designated by *To.*, and “the blade” or “on the blade,” by *Bl.*

In laying out polygons, the student should construct the geometric figure, extending the base line as in Fig. 50, in order to find the exact figures on *To.* and on *Bl.*, which will construct the angle. Numbers commonly used will be remembered easily.

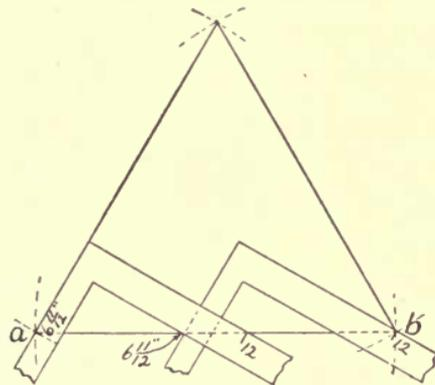

FIG. 49. — CONSTRUCTION OF AN EQUILATERAL TRIANGLE.

Hold the square as described in Topic 31, B; keep 12 *Bl.* upon the base line, and swing the square around until *To.* exactly coincides with the side of the polygon.

(B.) An equilateral triangle (Fig. 49), constructed in this way, will give 12 *Bl.*, $6\frac{1}{2}$ *To.*; *To.* = outside angle of the sides as at a . The miter of the triangle will be found upon

the blade at *b*. Throughout work of this kind, the number 12 will be almost invariably the blade number, hence the tongue number will be the only one to be kept in mind.

NOTE.—The figures given may not be found absolutely correct if calculated mathematically, but they are sufficiently accurate for all practical purposes, and adapted to the 1" scale upon the square.

(C.) The *hexagon* may be constructed by joining six equilateral triangles within a circle, the radius of which equals one side of a triangle. The vertex angles of a hexagon are $\frac{360^\circ}{6} = 60^\circ$; thus the same figures upon the square are used as for the equilateral triangle, the tongue giving the angle, as at *a*, Fig. 50. The miter, being the side of an

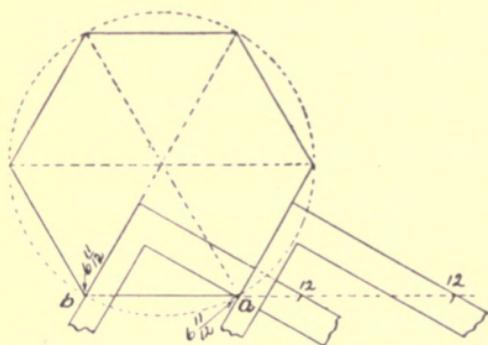

FIG. 50.—CONSTRUCTION OF A HEXAGON.

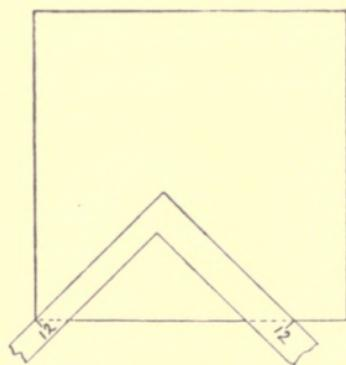

FIG. 51.—CONSTRUCTION OF A RECTANGLE.

equilateral triangle, is found by using the same figures, the tongue giving the miter cut, as at *b*.

(D.) The sides of a *rectangle* are square with the base line, or at an angle of 90° , the miter of which, $\frac{90^\circ}{2} = 45^\circ$,

may be obtained by using the same figures on both *To.* and *Bl.*, say 12, either side giving the cut. (Fig. 51.)

(E.) The *octagon*, or eight-sided polygon, treated in the same way, gives 12 *To.*, 12 *Bl.*, for the outside angle, either side giving the cut. For the miter, 12 *Bl.*, $4\frac{1}{2}$ *To.*; *To.* = cut. (See Fig. 52.)

The above-mentioned polygons are the ones commonly used by carpenters, though any regular figure may be constructed by the same methods.

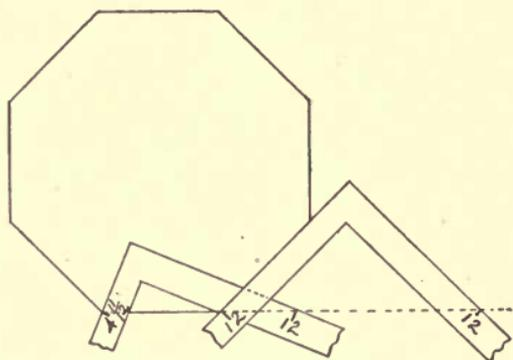

FIG. 52. — CONSTRUCTION OF AN OCTAGON.

(F.) A bevel set to the figures upon the square which have been found by the above methods will be found more convenient than the square itself in marking cuts and angles, if a number are to be made alike.

35. To bisect an angle. — (Fig. 53.) Measure equal distances on each side of the angle, *abc*, for points *d*

and *e*. With the same figure upon each side of the square held to the points *d* and *e*, *f* of the square will indicate the point through which a bisecting line, *bg*, may be drawn.

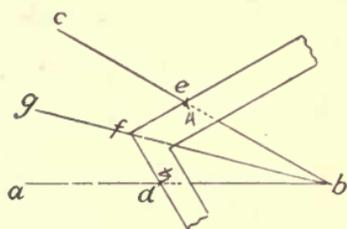

FIG. 53. — BISECTING AN ANGLE.

36. To find the center of a circle from three given points. — (Fig.

54.) Given points *a*, *b*, *c*, connect *a*, *b* and *b*, *c* with straight lines.

Find exact centers of these lines, and mark them *d*, and

e, respectively; from *d* and *e*, at right angles with lines *ab* and *bc*, construct lines extending in the direction in which they will meet. The point of intersection is the center of a circle which will pass through the given points.

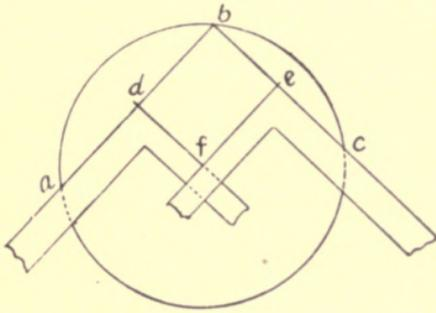

FIG. 54. — CONSTRUCTION OF A CIRCLE FROM THREE GIVEN POINTS.

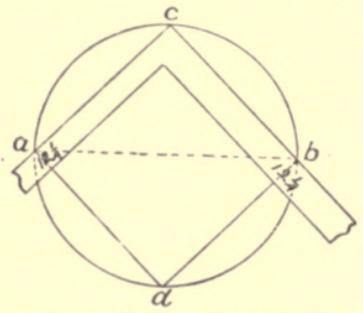

FIG. 55. — CONSTRUCTION OF THE GREATEST POSSIBLE SQUARE WITHIN A GIVEN CIRCLE.

37. To construct the greatest square within a given circle. — (Fig. 55.) Draw the diameter, *ab*, and place the angle of the square upon the circumference within the circle, moving the square until equal figures upon both *Bl.* and *To.* rest upon the diameter at its intersection with the circle. The angle of the square should be marked *c* upon the circumference; a line drawn through the center of the circle from *c* to the other side will give *d*, or the fourth corner of the square. Connect *a*, *c*, *b*, *d*, with straight lines.

38. To construct a square. — (A.) $\frac{1}{2}$ area of a given square. (Fig. 56.) Given the square *a b c d*, lay the framing square upon one side, say *ab*, with equal figures upon *To.* and *Bl.*, resting upon *a* and *b*. Lines drawn along the two edges of the framing square to *e* will give two sides of a square $\frac{1}{2}$ the area of the given square. Locate *f* by turning the square around.

(B.) *Twice the area of a given square.* — (Fig. 57.) The same solution may be applied, by using the diagonal of the given square $a b c d$, as one side of the desired square.

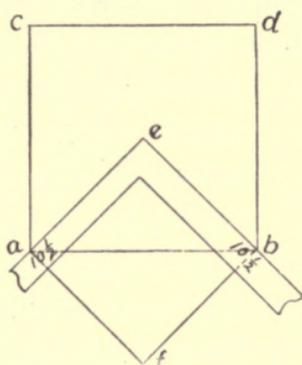

FIG. 56. — CONSTRUCTION OF A SQUARE OF ONE HALF OF THE AREA OF A GIVEN SQUARE.

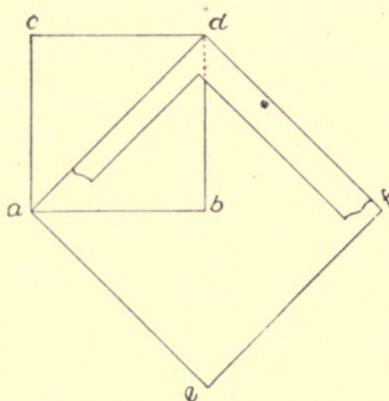

FIG. 57. — CONSTRUCTION OF A SQUARE TWICE THE AREA OF A GIVEN SQUARE.

39. *To construct a circle which shall equal the area of two given circles.* — (Fig. 58.) With the diameter of the smaller circle a upon $To.$, and that of the larger circle b upon $Bl.$, the bridge measure, c , or the hypotenuse, will equal the diameter of a circle equal to the area of the two given circles. By working circles in pairs, one may be found which will equal any number of circles.

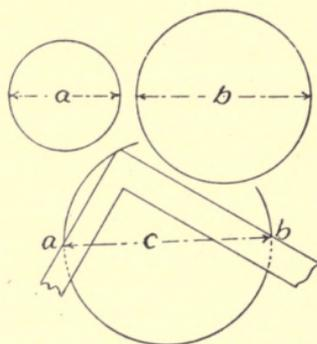

FIG. 58. — CONSTRUCTION OF A CIRCLE EQUAL TO THE AREA OF TWO GIVEN CIRCLES.

40. *To octagon a given timber.* — (A.) *Method 1.* — (Fig. 59.) In the middle of $To.$, upon the back of the square, will be found a series of dots, $a-b$, forming the octagon scale.

In using this scale to octagon a 6'' × 6'' timber for instance, a center line is drawn upon one side of the timber

and a space equal to six dots of the octagon scale laid off each side of the center line, as indicated at *c, d*. This gives the width of one side of the octagon, and the distance from the corner may then be

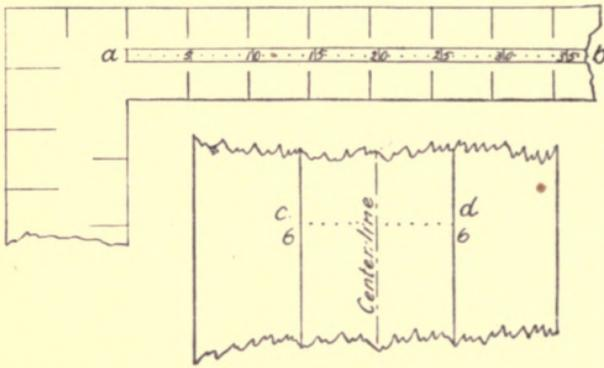

FIG. 59. — TO OCTAGON A GIVEN TIMBER. METHOD 1.

lined off from the edge of each side, or if preferred, from the center line.

(B.) *Method 2.* — (Fig. 60.) Lay *B1.*

of the square upon the given timber, as shown in the figure, the angle of the square and the outside corner of the other end just touching the edges of the sides of the timber; with a sharp pencil make points at 7 and 17. A line drawn through these points parallel with the edge will give the corners of the octagon.

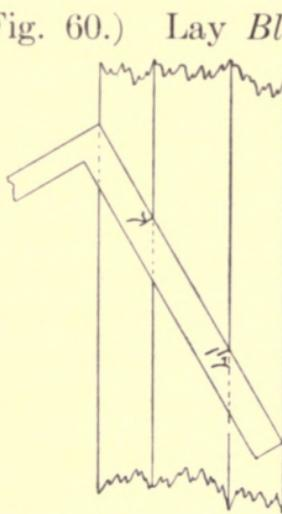

FIG. 60. — TO OCTAGON A GIVEN TIMBER. METHOD 2.

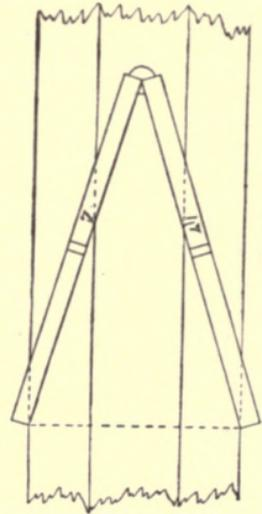

FIG. 61. — TO OCTAGON A GIVEN TIMBER. METHOD 3.

This process should be repeated upon each side of the

timber or lined off from the corners. A rule may be used in the same way, working from end to end.

(C.) *Method 3.* — (Fig. 61.) Lay a rule upon the timber, as shown in the figure, with the inside points just touching the sides, and upon a line perfectly square with the edge; mark, 7 and 17, as shown, and proceed as previously described.

(D.) *Method 4.* — (Fig. 62.) A very common method is to lay out the side of the timber, as shown in the figure, using the corners as centers, and one half of the length of the diagonals as radii of circles.

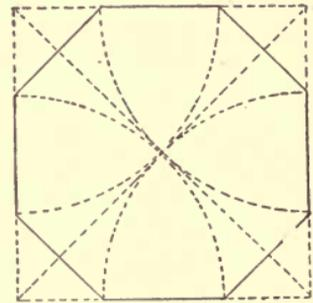

FIG. 62. — TO OCTAGON A GIVEN TIMBER. METHOD 4.

The following problems will be found valuable in laying out the runs of rafters for buildings which are octagonal or hexagonal in shape.

41. Given the side of an octagon, to find the width. — (Fig. 63.)

Given the side ab of the octagon, locate point c by resting equal figures of $Bl.$ and $To.$ upon a and b .

Apply Formula 1.

W = width of octagon.

FORMULA 1. $W = ab + 2ac$.

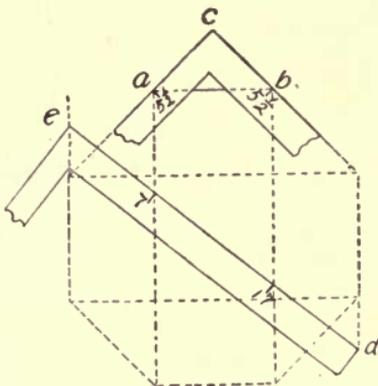

FIG. 63. — GIVEN THE SIDE OF AN OCTAGON TO FIND THE WIDTH.

Another method is to reduce the side of the octagon to an inch scale, and to make two parallel lines upon the bevel board as far apart as the

45. Given the width of an octagon, to find the length of a side. — (Fig. 63.)

Draw two parallel lines as far apart as the width of the octagon, generally using the inch scale. Use the figures 7 and 17, as described in Topic 40, B.

Another, and the more common method, is to construct a square on the given width of the octagon, and work from the diagonals, as described in Topic 40, D. (See Fig. 62.)

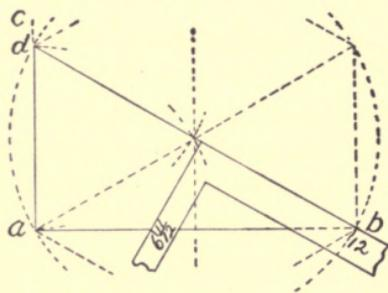

FIG. 66. — GIVEN THE WIDTH OF A HEXAGON TO FIND THE SIDE.

46. Given the width of a hexagon, to find the side. — (Fig. 66.)

S = side of hexagon.

Method 1. Draw the line ab = given width of the hexagon. Erect an indefinite perpendicular, ac , from a .

Let 12 *Bl.* rest at b ; $6\frac{1}{2}$ *To.* on ab . Continue line of *Bl.* to ac . Mark intersection, d . Apply Formula 5.

$$\text{FORMULA 5. } S = ad.$$

Method 2. Bisect the line ab and erect an indefinite perpendicular; use the square as in method 1. The intersection of the line bd with the perpendicular = S .

SUGGESTIVE EXERCISES

31. What are the dimensions of the blade and the tongue of the standard steel square? Into what fractional parts of an inch is each edge of a square divided? Which is the face side of the square? What is the length of the blade upon the scale of 1'' to 1'? Of the tongue? Lay off 18' 9'', using the 1'' scale; 21' 6''; 9' 7''. Demon-

strate the use of the board measure. How many feet are there in a board 16' long, and 11'' wide? 18' long, 22'' wide? Demonstrate the use of the brace measure. The use of the diagonal scale.

32. What are the accessories for working out steel square problems?

33. Demonstrate the use of the steel square in dividing a board into any number of equal parts.

34. Demonstrate the method of finding the number of degrees in each angle of a regular polygon. Of finding the degrees in the miter of a polygon. What is always the sum of the two angles with the hypotenuse of a right angle triangle? What are the symbols of the blade and the tongue? Demonstrate the method of finding the figures upon the square which will give the angles and miters of a polygon.

Construct by this method an equilateral triangle; a rectangle; a hexagon; an octagon. What tool is a convenience in marking duplicate angles?

35. Demonstrate the method of bisecting an angle with a steel square.

36. Demonstrate the method of finding the center of a circle which will pass through three given points.

37. Demonstrate the method of finding the greatest square which can be contained within a given circle.

38. Demonstrate the method of finding a square one half the area of a given square. Demonstrate the method of finding a square twice the area of a given square.

39. Demonstrate the method of constructing a circle equal in area to two given circles. How may the problem be applied to any number of circles?

40. Demonstrate the use of the octagon scale. What figures upon the side of a square will give the width of the side of an octagon? Demonstrate its use. What other tool may be used in the same way? Demonstrate the method of finding the sides of an octagon from the diagonals of a square.

41. Demonstrate the method of finding from a given side the width of an octagon. What previously given method may be reversed to give the same results?

42. Demonstrate the method of finding from a given side the width of a hexagon.

43. Demonstrate the method of finding the diagonal of an octagon from its given side.

44. Given the side of a hexagon, demonstrate the method of finding its diagonal.

45. Given the width of an octagon, demonstrate the method of finding the length of the side. By what other previously described method may the problem be solved?

46. Given the width of a hexagon, demonstrate two methods of finding the length of the side.

CHAPTER V

ROOF CONSTRUCTION

47. **Pitches of roofs.** — There are three terms used in describing the dimensions of roof pitches: the “run”

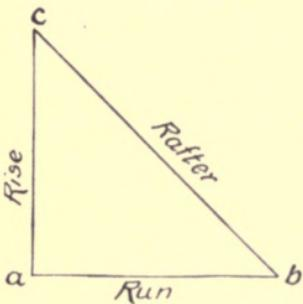

FIG. 67. — ROOF DIMENSIONS.

(ab , Fig. 67) is the horizontal distance between the plate, b , and the point a , directly under the apex of the roof, c ; the “rise” is the vertical distance between a and the apex of the roof, c ; the “pitch,” or “line of the rafter,” is the angle or line between b and c .

There are three pitches in common use in the construction of pitch roofs, the *half*, *third*, and *quarter* pitches (Fig. 68). The angles at b and c (Fig. 67) of any one of these pitches are always the same, no matter what the dimensions of the run and rise or the plan of the house may be.

The run of a pitch roof house is half of its width at the outside of the plate.

The rise of any of the above pitches may be found

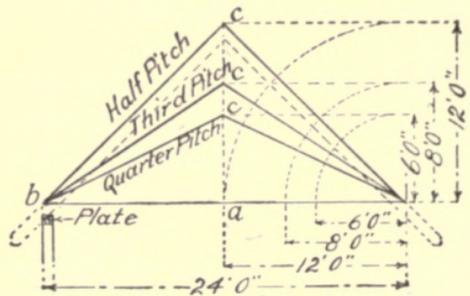

FIG. 68. — ROOF PITCHES.

by dividing the width of the house, or the distance between the outsides of the opposite plates, by 2, 3, or 4,

as a half, third, or quarter pitch may be desired. This will give the height of the roof to its apex, measuring from the base line, or the line of the outside of the plate, upon the top of the rafters, as shown at *k*, Fig. 71. The rafter will be discussed later.

The following formulas illustrate the mathematical method of finding the lengths of the run and of the rise of a roof.

W = width of the house.

R = run.

A = rise of the roof, or altitude of the triangle.

$$\text{FORMULA 6. } R = \frac{W}{2}.$$

Rise of the half pitch roof.

$$\text{FORMULA 7. } A = \frac{W}{2}.$$

Rise of the third pitch roof.

$$\text{FORMULA 8. } A = \frac{W}{3}.$$

Rise of the quarter pitch roof.

$$\text{FORMULA 9. } A = \frac{W}{4}.$$

Thus, the dimensions of a third pitch roof, of a house 28' wide, would be found as follows:—

$$R = \frac{W}{2} = \frac{28'}{2} = 14'.$$

$$A = \frac{W}{3} = \frac{28'}{3} = 9' 4''.$$

48. The different forms of roofs are illustrated in Fig. 69. The *lean-to*, or *shed roof*, *a*; the *pitch* or *gable roof*, *b*; the *hip roof*, *c*; the *gambrel roof*, *d*; the *French roof*, *e*; the

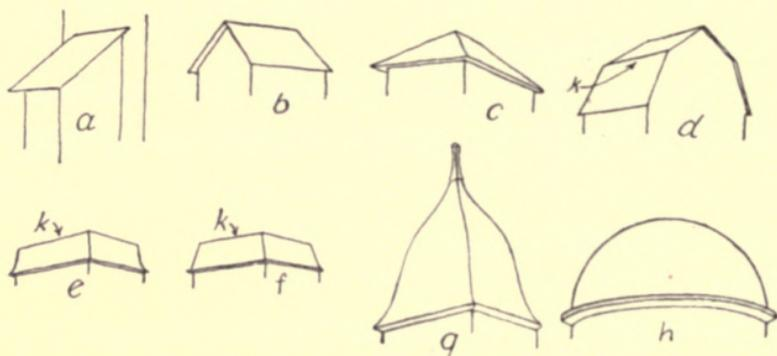

FIG. 69. — DIFFERENT FORMS OF ROOFS.

a, shed or lean-to; *b*, pitch or gable; *c*, hip; *d*, gambrel; *e*, French; *f*, mansard; *g*, ogee; *h*, dome.

mansard roof, *f*; the *ogee roof*, *g*, used in turret and tower construction; and the *dome roof*, *h*. The hip roof here illustrated is also a pitch roof, but the term "hip" applies to any one form of roof pitch which has hipped corners. Its general application is, however, to the roof illustrated. The roofs *d*, *e*, and *f* are known also as *curb roofs*, since a curb plate is used in their construction, at *k*.

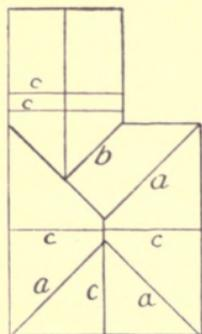

FIG. 70. — ROOF PLAN.

49. The plan of the roof. — (Fig. 70). In *laying out the plan of a roof*, it is best to be governed by the greatest rectangle that can be obtained from the plan of the house, angles and projections being framed by means of hip rafters (*a*) or valley rafters (*b*). This roof contains all the rafters and cuts necessary for framing any rectangular pitch

roof of equal pitches, though the principles involved may be applied to any angles or to any combination of pitches.

In laying out the rafters and cuts of a roof, a plan or sketch showing the location of every piece entering into its construction should be made, unless the roof is a very simple one. If an architect draws the plans of the house, a roof-framing plan is generally furnished. The safest plan is to estimate the lengths of the principal members of the roof before commencing work, as the men may more easily be kept working to advantage; in fact, this should be done, in order that lumber of the dimensions which will cut most economically may be upon the ground ready for work.

50. **The common rafter.** — (Fig. 71). (A.) The length of a *common rafter* is not from the apex of the roof to the eaves, but from the apex of the roof to a point directly over the plate, upon the top edge of the rafter, as in the figure. If a ridge is used, one half of its thickness must be taken off parallel with the plumb cut at the top end of the rafter, as will be described later in this topic. If there is a lookout upon the rafter, the stick must be long enough for it to be added, though upon an open cornice roof the lookouts are usually sawed to some design, and nailed upon the sides of the rafters.

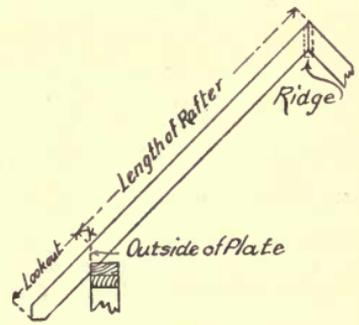

FIG. 71. — COMMON RAFTERS.

The following is a key to the formulas for finding the length of a common rafter:—

H = length of rafter.

R = run of rafter.

A = rise of rafter.

T = pitch line of $\frac{1}{2}$ of the thickness of the ridge.

X = bridge measure.

T_1 = thickness of ridge.

P = plumb cut (ridge, or face cut).

C = constant of rise of roof — 6, 8, or 12.

S = seat (plate cut).

The length of any kind of rafter of any pitch may be found mathematically by using the following formula:—

$$\text{FORMULA 10. } H = \sqrt{R^2 + A^2}.$$

The length of any rafter may be found upon the steel square thus:—

$$\text{FORMULA 11. } H = X \text{ of } R \text{ on } Bl., A \text{ on } To.$$

If the square is laid upon the rafter with A on the tongue, and R on the blade, $To.$ will give P , and $Bl.$ will give S ; these figures are rarely used in marking angles, as their principal use is in ascertaining the length of the rafters, though they are frequently used when irregular roofs are being framed. The length of any straight rafter, of any pitch, anywhere in the roof, may be found by applying the above method, though in certain instances there are better methods of finding it. Upon intricate work, it is best to use the mathematical formulas, as well as the steel square, to insure accuracy, as one proves the other.

(B.) The cuts of any of the three common pitches may be found by using formulas 10 and 11, working from the

actual dimensions of the roof; but in practice it is the custom to use constants which will always give the cuts for the standard pitches, since, if the rafters are square with the plate, neither the pitch nor the angle of the cuts changes, whatever the length of the rafter, or the size of the house.

These constants are obtained by using the dimensions of a house 24' wide, as 12' is the run, and the rise of all of the standard pitches will be even feet with no fractions. Thus working from an inch scale, 12 *Bl.* will be the constant for the run of all pitches.

The constant for the rise of a half pitch roof, on the above house, is therefore: $\frac{24}{2} = 12$; for a third pitch roof: $\frac{24}{3} = 8$; for a quarter pitch roof: $\frac{24}{4} = 6$; either 12, 8, or 6 *To.*

If a two thirds or a three fourths or any other pitch is wanted, its constant may be found in the same way.

In Fig. 72 is illustrated the method of laying off the angles of common rafters, giving the constants to be used for the common pitches, —

the edge *ab* of the bevel board being the pitch, or rafter line, the line of *Bl.* being the run, and the line of *To.* being the rise. This

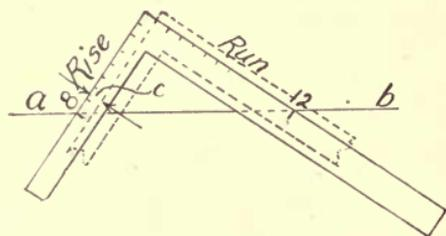

FIG. 72. — LAYING OUT THE PLUMB OR RIDGE CUTS OF A COMMON RAFTER.

seems an awkward position, but after a little practice the student will have no trouble. Thus, 12 *Bl.*, 12 *To.* = $\frac{1}{2}$ pitch; 12 *Bl.*, 8 *To.* = $\frac{1}{3}$ pitch; and 12 *Bl.*, 6 *To.* = $\frac{1}{4}$ pitch. In every case *To.* gives the plumb or ridge cut, and *Bl.* gives the seat or the plate cut.

It should be remembered that in all of the following

problems in the use of the steel square, those which deal with rafters, the runs of which are square with the plate, have in every instance 12 *Bl.* as the constant for the run. The student should be careful not to use the constant for the *length of the rafters*, unless a house 24' wide is being framed, and the rafters are square with the plate. A house of that width, or one with a run of 12', is the only one for which the constants will give the correct results. Instead, use the actual dimensions of the rise and the run to obtain the length, as in formulas 10 and 11. In laying out rafters of all kinds, always work from the top of the stick, which should be the crowning or rounding edge.

In laying out the common rafters, or any pieces which should be just alike, it is the custom to lay out one, and mark the others by it. For an example, we will lay out the first common rafter for a third pitch roof.

Lay the square upon the stick, as shown by the full lines of Fig. 72, and mark *To.*, the angle of the plumb cut. Calculate the length of the rafter by either or both, formulas 10 or 11; measure this distance from the ridge cut toward the other end of the stick, and mark the seat cut. In laying out the length of common rafters, for instance, for a third pitch house with a run of 12' 8'', the length of the rafter, working to the nearest 16th of an inch, would be 15' 3''.

The method of using the square in laying out the seat or plate cut is shown in Fig. 73 in which the apparently awkward position of Fig. 72 is repeated. The end of the rafter at the plate is indicated by point *k*, which is made upon the top edge of the rafter, and is identical with point *k* of Fig. 71. It will be directly over the outside of the

plate when the rafter is in position. Fig. 73 shows the method of working from point *k*, to lay out the "bird's mouth" joint which fits over the plate. A line is drawn from *k* to the under edge of the rafter, as at *kc*, and the plumb height, *kd*, about 3", is measured from *k* upon this line. Keeping the square at the same figures, 12 *Bl.* and 8 *To.*, slide it along until the *Bl.* coincides with *d*; draw this line from *d* to *e*. The triangular piece, *cde*, must be cut out to allow the rafter to fit the plate. The seat or plate cut, *de*, will rest upon the top of the plate; while *dc* fits against the outside of the plate when the rafter is in position, as in Fig. 71. A plumb height of from 3" to 4" according to the pitch and size of the stick is left from the plate to the top of the rafter, as at *dk*, Fig. 73, to give room for fastening the lookout on its side.

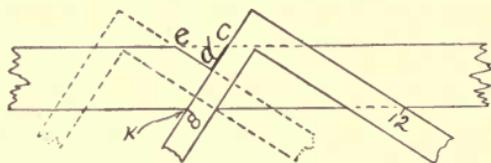

FIG. 73. — LAYING OUT THE SEAT OR PLATE CUT OF A COMMON RAFTER.

If a ridge is to be used, the mathematical formula for finding the length of the rafter is as follows:—

$$\text{FORMULA 12. } H = \sqrt{R^2 + A^2} - \frac{\sqrt{T_1^2 + \left[\frac{C}{T_1} \right]^2}}{2}$$

In using a steel square to lay out a common rafter, which is to rest against a ridge, the first rafter should be laid out as though it were to be cut full length. Measure the distance *c* (Fig. 72), which equals one half of the thickness of the ridge, square from the plumb cut of

the rafter, and draw a line as indicated by *To.* of the dotted square. Square across the edges of the rafter at the plumb and seat cuts, and saw accurately to the marks. Using this rafter as a pattern, lay out and cut as many as may be desired.

(C.) The sizes of the common rafters generally used upon ordinary work are as follows: 10' 0" or less in length, 2" \times 4"; if longer, a purlin should be used or a 2" \times 5" or a 2" \times 6" rafter. If a rafter more than 16' long is needed, it is common practice to use a purlin if possible, rather than very heavy rafters.

(D.) Upon the better class of buildings it is customary to space the rafters 16" to centers, thus allowing both the covering boards and laths to be cut economically, and giving four nailings for the latter. Many architects and builders consider that this spacing adds to the weight and expense of the roof more than is necessary upon ordinary buildings, and therefore space the rafters 20" or 24" to centers. The former distance requires that 10' or 12' covering boards should be used to prevent too much waste if a plain roof is being built, but if the roof is broken by dormer windows, hips, and valleys, this is not an important consideration. If the ceiling of the attic is to be plastered, the 20" spacing will not allow the laths to be cut economically.

The 24" spacing will allow both the covering boards and the laths to be cut with the minimum of waste, though the distance between the rafters is greater than it should be for nailings, more especially in nailing the laths, though many reputable builders consider that as there is not the vibration to the roof that there is to a

floor, the 24'' spacing gives satisfactory results if thick laths are used and the mortar is well clinched.

51. Lookouts. — *Lookouts* for the common rafters of a box-corniced house are usually part of the same stick as the rafter, if they do not require too long a stick to be practicable; but if an open cornice is to be built, the lookouts are generally sawed to some design, and the pitch ends of the rafters cut as shown in Fig. 21, the lookouts being spiked on as indicated. The length of the lookouts may be found by using the pitch and the base lines of the rafters, laying *Bl.* upon the base line, and sliding it until the figure upon *Bl.* denoting the horizontal projection of the lookout beyond the plate coincides with the pitch line, say 20'', where a mark by the tongue upon the pitch line should be made, as shown at *a* in Fig.

74. The distance, or bridge measure, between *a* and *b*, is the length of the lookout on the line with the top of the rafter of which it is a continuation. To this must be added about a foot for spiking to the rafter.

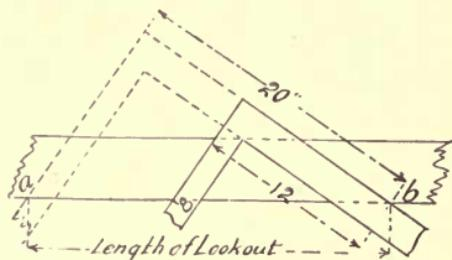

FIG. 74. — TO FIND THE LENGTH OF THE LOOKOUT.

The formula for finding the length of a lookout for a common rafter is as follows : —

L_2 = horizontal projection of lookout.

L_3 = length of lookout.

X = bridge measure.

FORMULA 13. $L_3 = X$ of L_2 on *Bl.* as base line, and intersection of *To.* with pitch line.

The mathematical formula for finding the length of the lookout is as follows:—

A = rise of lookout.

$$\text{FORMULA 14. } L_3 = \sqrt{L_2^2 + A^2}.$$

52. The ridge. — Many houses are built without a ridge, the common rafters fitting against each other, and being spiked there, but it is better to use one, especially upon a hip roof, where it is almost a necessity, though the hip rafters are supported sometimes by the common rafters, a practice not recommended.

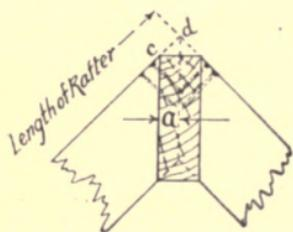

FIG. 75. — ALLOWANCE FOR THICKNESS OF THE RIDGE.

A 2'' × 6'' is sometimes used as a ridge, though a 1'' board is used commonly upon light buildings. The hip and common rafters should join the ridge as shown in Fig. 75, and upon a pitch or gable-roofed house, the

ridge should be cut the same length as the plate with which it is parallel.

The formulas for finding the length of the ridges of roofs which have hips are both mathematical:—

L_1 = length of ridge.

R_3 = run of common rafter.

T_4 = horizontal width of cheek cut of hip.

T_1 = thickness of ridge.

L = length of side plate.

To find the length of a ridge for a half hip house, or one gable and two hip rafters:—

$$\text{FORMULA 15. } L_1 = L - \left(R_3 + \frac{T_4 + T_1}{2} \right).$$

To find the length of the ridge for a full hip roof :—

FORMULA 16. $L_1 = (L - W) + (T_4 + T_1)$. See *b*, Fig. 77.

To find T_4 by the square, lay the square across the edge of the hip rafter at the horizontal angle at which the ridge intersects it (the same figures upon both $To.$ and $Bl.$ for a rectangular house) when in position, as in Fig. 76; the distance from a to $b = T_4$.

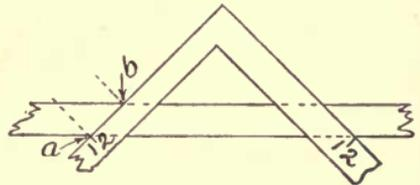

FIG. 76. — DIAGONAL OF THE THICKNESS OF THE HIP RAFTER.

53. Hip rafters.— (A.) By referring to Fig. 70, it will be seen that the plan, base line, or the run of a hip rafter, a , of a rectangular roof of equal pitches, is at an angle of 45° with the plates of the house, and equals the length of the diagonal of a square formed by the runs of the common rafters, c , of the adjoining sides of the main house.

The rise of a hip rafter is the same as the rise of the common rafter which extends to the same height as the top end of the hip rafter, or which stops at the ridge against which the hip rafter is fitted, if a ridge is used.

(B.) The length of a hip rafter is measured from the apex of the hip to the line of the outside of the corner of the plates, upon the top of the rafter, and is the hypotenuse of a right angle triangle, of which the other two sides are the rise and the run.

Its length may be found mathematically by using the following formula:—

$$R = \text{run of the hip rafter} = X \text{ of } R_3 \text{ upon } To. \text{ and } Bl.$$

$$X = \text{bridge measure.}$$

A = rise of the roof.

H = length of the hip rafter.

R_3 = run of the common rafter.

$$\text{FORMULA 17. } H = \sqrt{\sqrt{2} R_3^2 + A^2}.$$

The length of the hip rafter may be found with the steel square thus:—

FORMULA 18. $H = X$ of R on $Bl.$, and A on To .

If a perfectly square roof is being framed, the hip rafters should be joined at the apex of the hip by the method indicated at a , Fig. 77. The first pair of hip rafters c, c , should be

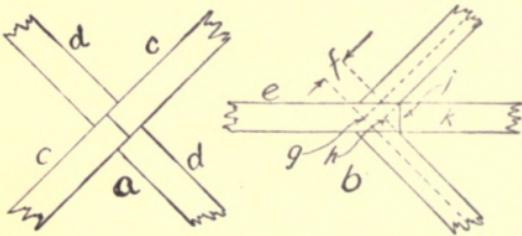

FIG. 77. — RIDGE AND HIP RAFTERS.

a , method of joining hip rafters of a square house;
 b , method of joining hip rafters to a ridge.

d, d , should be made shorter than rafters c, c , a distance equal to one half of the thickness of the rafters c, c , for the same reason that the plumb cuts of common rafters which rest upon a ridge are shortened one half of the thickness of the ridge, as explained in the last paragraph of B, Topic 50. The cuts of both ends of the hip rafters framed by this method are square with the sides, as though common rafters of the same dimensions were being cut. See Formulas 11–12.

If the house is longer than it is wide, a ridge should be used; in which case, the hip rafter will have to be short-

ened by measuring back from the plumb cut, which indicates the exact length of the rafter, a distance equal to f , of Fig. 77, or one half of the diagonal thickness of the ridge; this must be measured square from the plumb cut upon the side of the rafter. In doing this, it should be remembered that the measurements of a rafter are made upon the center line of its top edge, thus the long corner of a hip rafter, see a , of a , Fig. 79, will be longer than the actual length of the rafter. This difference will equal the distance of the hip pitch line in a run equal to one half of the thickness of the hip rafter. K of Fig. 77 shows a common rafter which should be shortened the distance from g to the end of the ridge j , parallel with the plumb cut.

The length of a hip rafter which fits against a ridge may be found mathematically by using the following formula:

H_1 = length of a hip rafter which rests against a ridge.

R_3 = run of the common rafter.

A = rise of the roof.

C = constant; found by calculating the ratio of the rise of the hip to its run; for half pitch it is equal to .707; for a third pitch, .47; and for a quarter pitch house, .353.

D = diagonal thickness of the ridge at the angle of the intersection of the hip rafter; in a rectangular house, it would be equal to $\sqrt{T_1^2 + T_1^2}$. If a 2" ridge is being used, $D = 2.823''$. If the ridge is a $\frac{7}{8}''$ board, $D = 1.23''$.

T_1 = thickness of the ridge.

$$\text{FORMULA 19. } H_1 = \sqrt{\sqrt{2 R_3^2 + A^2} - \frac{\sqrt{D^2 + C^2}}{2}}$$

The formula would be applied to the steel square as follows:—

X = bridge measure.

R_1 = run of hip rafter.

A = rise of hip rafter.

H_1 = length of hip rafter.

T_3 = hip pitch line of the thickness of the ridge.

FORMULA 20. $H_1 = X$ of R_1 on $Bl.$, A on $To.$ — $\frac{T_3}{2}$.

The method of finding T_3 upon the steel square is illustrated by Fig. 78. Upon the top edge of the ridge indicate

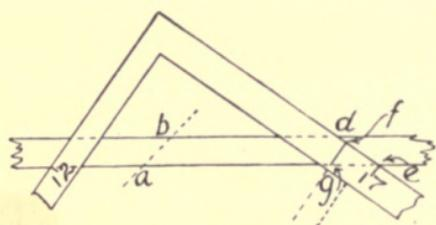

FIG. 78. — METHOD OF FINDING THE HIP PITCH LINE OF THE THICKNESS OF THE RIDGE.

the angle at which it is intersected by the hip, as at ab , using the constants described in subtopic *C* of this section — in this case, 12 $To.$, 17 $Bl.$ — lay out R_1 by the blade of the square as indicated at de ; transfer the distance ab , the run of the hip in the thick-

ness of the ridge, to ef ; erect the perpendicular, fg , by sliding the tongue of the square to f , marking g accurately. The distance $ge = T_3$. For a house in which R_1 is at any angle but 45° with the plates, the actual rafter dimensions should be used.

In finding the length of the common rafters, we used the common rafter dimensions, though they may have been used for the cuts; likewise, in obtaining the length of hip rafters, we use the hip rafter dimensions, though the same figures may be used for the plumb and seat cuts.

(C.) As there are constants which give the cuts for common rafters, so there are constants which will give the angles of the *seat and plumb cuts* for hip rafters.

As we have found, the run of a hip rafter equals the diagonal of a square formed by the run of the common rafters. Therefore, returning to the 24' house mentioned in *B*, Topic 50, we find that the run of the common rafter is 12' 0'', the diagonal of which will be a constant applicable to the runs of all hip rafters, as 12 is the constant of the run of all common rafters.

With the usual mathematical formula for finding the length of the hypotenuse of a right-angled triangle, we will find the desired constant for the run of the hip.

B = base.

A = altitude.

H = hypotenuse.

$$\begin{aligned} \text{FORMULA 21. } H &= \sqrt{B^2 + A^2} = \sqrt{144 + 144} \\ &= \sqrt{288} = 16.971 \text{ feet.} \end{aligned}$$

This means that the run of the hip rafter of a 24' house is 16.971', but in practice it is customary to use 17 for the constant, as it is near enough for all practical purposes.

As the rise of the roof is the same for a hip rafter as for a common rafter, it is obvious that the constant used for the rise of the common rafters will be used for the rise of the hip.

Thus the constant for the run of the hip and valley rafters of any rectangular house of even pitches will be 17, and the constant for the rise of the hip and valley rafters will be 12, 8, or 6, as the roof is half, third, or quarter pitch.

$A = 12, 8, \text{ or } 6$, the constant of the rise of the hip rafter.

$P =$ plumb cut.

$S =$ seat cut.

$R_1 = 17$, or the run of the hip rafter.

FORMULA 22. 17 on *Bl.*, A on *To.*, $Bl. = S$, $To. = P$.

(D.) Having found the plumb and seat cuts, we must next find the *side or cheek cuts*, which should be made at the same time that the ridge or plumb cut is made, as the rafter fits against the ridge, which it intersects in the plan at an angle of 45° , upon an ordinary roof, as shown at *b*, Fig. 77. The simplest method of obtaining this cut, for a square house, is to lay off the plumb cut, ab , of a , Fig. 79, upon the side of the hip rafter; measure the thickness of the rafter, c , or $2''$ parallel with the plumb or ridge cut, and draw the line de . Square across the top edge of the rafter to the other side, locating the point f ; draw a line from f to a diagonally across the top edge of the hip, obtaining thus the desired cheek or side cut.

FIG. 79. — METHOD OF FINDING THE CHEEK CUTS.

The student should study this problem carefully, as it involves the principle by which all side or cheek cuts are made, according to the method taught in this book. It will be seen by the plan of the roof that the horizontal angle of the intersection of the hip rafter and the ridge is an angle of 45° ; the fact that the center of the roof is higher

than at the plates does not alter in the slightest degree that angle. Therefore in taking off the cheek cut equal to the thickness of the rafter we are making what is simply a square miter joint, when the horizontal section is considered.

In order to assist the student to a better understanding of this problem, let him draw a diagram similar to *b*, Fig. 79. Square across the hip rafter from the short corner *a* to the long side, at *b*, and measure from *b* to *c*. This will give the distance which should be measured back parallel to the ridge or plumb cut of the rafter, as at *c*.

In this case it will be the thickness of the rafter, but if the angle of contact between the hip and the ridge was any other angle, the distance *bc* would vary accordingly, as indicated by the dotted lines. This method may be applied to any angle of intersection where a cheek cut is necessary.

In cutting hip rafters the top end usually is cut first, and the length taken from the center of the side or cheek cut, upon the top edge, as at *b*, Fig. 77. Point *g* indicates the exact length, and the distance *f* shows the horizontal allowance which must be made for one half of the thickness of the ridge.

(E.) The *graphic method* of laying out the cuts of hip rafters is described in Fig. 80, and is sometimes used upon intricate roofs, to prove the angles found by the steel square, though its principal use is in solving problems in roof construction which are published in the periodicals that circulate among carpenters.

In Fig. 80, the angle *a* is the plumb or ridge cut, and *b* the seat cut of a common rafter of a third pitch roof.

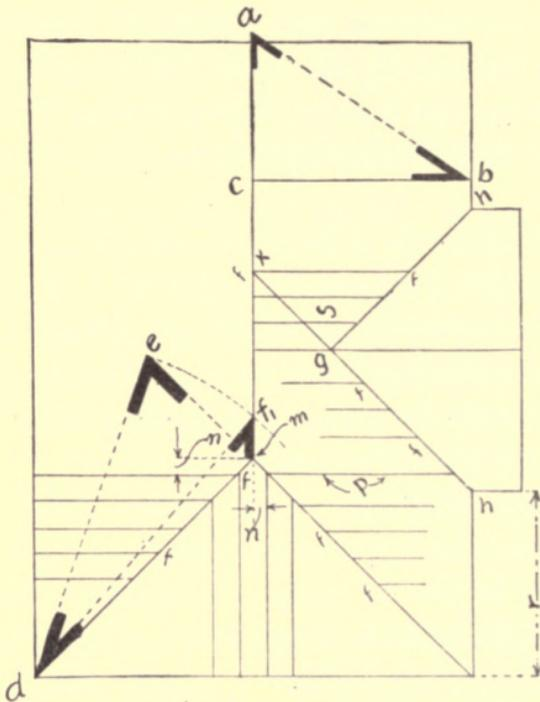

FIG. 80. — THE GRAPHIC METHOD OF FINDING THE LENGTHS AND ANGLES OF RAFTERS.

These may be found by drawing the run, *cb*, and the rise, *ca*, as shown, and connecting them by the line *ab*, which indicates the top or pitch of the rafter.

The roof plan of a house 24' wide of any pitch may be drawn to a scale and the bevels found; these will be the same in all rectangular houses of the same pitch.

In ascertaining the length, *de*, the plumb cut, *e*, and the seat cut, *d*,

of a hip or valley rafter, the same graphic method may be followed, the results being shown at *e* and *d*.

In order to obtain the cheek, or side cuts of the hip, valley, jack, and cripple rafters, set compasses at the radius *de*, and, with *d* as center, draw an arc cutting the ridge at *f*₁; connect *d* and *f*₁. The angle *f*₁ is the cheek cut of all of the rafter ends marked *f*. The top end of the valley rafter (*gh*) is cut the same as the plumb cut of a common rafter of the same rise and run. The plumb cut at the plate or at the end, *h*, of the valley rafters should be cut as shown at *a*,

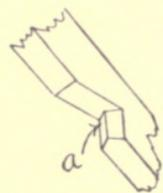

FIG. 81. — PLATE CUT OF VALLEY RAFTERS.

in Fig. 81, to allow them to fit into the inside angle of the plate.

(F.) *Backing a hip rafter* is illustrated by *a*, Fig. 82. The student should understand that as the rafter is measured in the center of the top edge, which is the line of the hip, the corners of the upper edge of the hip will project above the line of the common rafters, leaving a triangular space, as at *b*, if the plumb height at the plate is the same as that of the common rafters. The process of

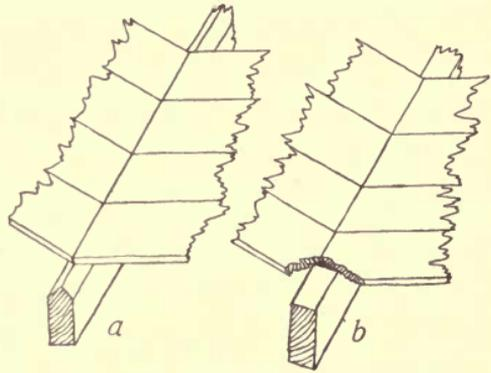

FIG. 82.

a, Backed Hip Rafter; *b*, Square Hip Rafter.

laying out and beveling the top of a hip rafter, as at *a*, so that the roof sheathing, or sheathing, will lie perfectly flat, and meet that of the other side of the hip, directly over the line of the hip, as at *a*, is called backing.

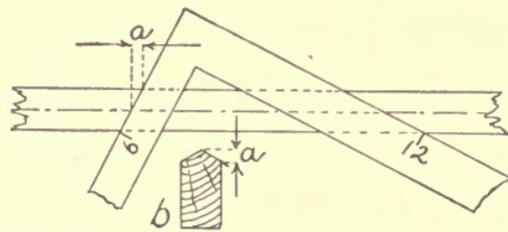

FIG. 83. — METHOD OF LAYING OUT THE BACKING.

the rafter; in this case, a half pitch rafter is illustrated. Transfer the distance, *a*, Fig. 83, to the side of the rafter, as shown at *b*. The wood between the center of the rafter on the top edge and the distance *a* on the side should be cut away.

The following formula will give the necessary bevel for the backing, or the amount which is to be cut off, and which should be laid off on the top of

B = backing.

R_3 = run of common rafter.

A = rise of the roof.

FORMULA 23. $B = R_3$ on $Bl.$, $\frac{A}{2}$ on $To.$ $To. = B.$

Hip rafters are rarely backed upon common work, as there is not enough gained to make it advisable. As a substitute, the plumb height of the rafter at the plate may be shortened a distance equal to the height of the backing (a , Fig. 83), which should be found by the above method. After the rafter is in place, the sheeting may be nailed across to meet that of the other side of the roof. This will leave a triangular hole between the sheeting and the top of the hip rafter, as shown at b of Fig. 82.

This method is perfectly satisfactory for common work, as the nails are driven into the corners of the hip which are flush with the common rafters.

54. Valley rafters. — The lengths and cuts of *valley rafters* (gh , Fig. 80) may be found by the same methods as those used in finding the lengths and cuts of hip rafters; if the valley is to fit against the ridge, as at k , the top cut is the same. The plumb side of the seat cut should be made as shown in Fig. 81, so that the center of the rafter may be fitted to the plate, as the center, a , is upon the line of the plumb cut. There is no difference in the plumb height of the valley and the common rafters at the plate, as the roof sheeting of both sides of the valley meets at the center of the top edge of the valley rafter, which is in line with the common rafters.

If the top of a valley rafter is cut against a hip, as at g ,

Fig. 80, the plumb cut is the same as that of a hip rafter, but the end cut is square across. This applies only to roofs of rectangular shape, and of even pitches.

55. Jack rafters. — The length of *jack rafters* may be obtained by using Formula 24, which is applicable to all pitches and angles.

R_4 = run of jack rafter.

A_2 = rise of jack rafter.

C = constant, which may be found by calculating the ratio of the rise of the jack rafter to its run. In a half pitch it = 1.00; in a third pitch, it = .67, and in a quarter pitch, it = .50.

D = horizontal thickness of the hip rafter at the angle of its intersection with the jack; upon a rectangular corner D would = 2.823".

H = length of the jack rafter.

$$\text{FORMULA 24. } H = \sqrt{R_4^2 + A_2^2} - \frac{\sqrt{D^2 + C^2}}{2}$$

A method of using the steel square to find the lengths of the jack rafters or of roofs of any pitch or angle is illustrated by Fig. 84, which is based upon quarter pitch, common rafters spaced two feet to centers. In finding the length of the jack rafter, draw the common

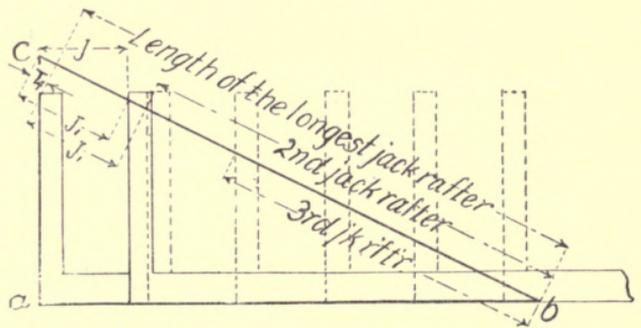

FIG. 84. — METHOD OF FINDING THE LENGTHS OF JACK RAFTERS.

rafter vertical diagram a, b, c , scaled, upon the bevel board; slide the square back from the rise, ac , of the common rafter upon the base line, ab , the distance equal to J of Formula 25. J_1 will give the distance, less the length of the common rafter, which the jack rafter should be cut, and from this must be subtracted $\frac{T_4}{2}$ of Formula 25. (See T_3 of Formula 20, Fig.

78.) The result thus obtained will be the actual length of the longest jack, and the others will be shortened a distance equal to the pitch line of J , or the distance J_1 of Fig. 84.

In using the square to lay out the length of the jack rafters, the following formula may be applied, if the center of the common rafter is placed at the apex of the hip rafter.

J = horizontal distance between centers of jacks. *

H = length of jacks.

H_1 = length of common rafter.

T_4 = pitch line of jack rafter, of the diagonal of the thickness of the hip.

J_1 = pitch line of J .

$$\text{FORMULA 25. } H = H_1 - \left(\frac{T_4}{2} + J_1 \right).$$

The above assumes that a common rafter is located at the apex of the hip; but if the center line of its top edge is not in line with the apex of the hip rafter, as shown in the rafter plan at m , Fig. 80, the above formula may be used by changing J in the formula key to read as follows: J = distance between the apex of the hip rafter, and the center line of the longest jack, as at n , Fig. 80. This will give only the length of the longest jack; the length of

the others may be found by shortening each one a distance equal to J_1 .

Many framers use the lower end of the hip rafter as the starting point, instead of the apex of the hip. The length of the first, or shortest jack, equals $J_1 - T_4$ of the above formula, laid off upon the base line of the roof, and each rafter is made longer than the preceding one, by a distance equal to J_1 .

The same principle is applied, but J_1 is added instead of subtracted, as described.

In favor of this method it may be said that if the rafters are set 2' to centers, throughout the length of the house, there may be less waste of stock in cutting sheeting, and in covering boards, and, if an open finish house is being built, uniformity in the spacing of the lookouts may sometimes be obtained more easily than if the common rafters were fixed at the apex of the hip rafters.

In finding the plumb and the seat cuts of jack rafters, the same constants are used as when cutting the common rafters. The side or cheek cuts are obtained in the same way as those of a hip rafter, since the jack comes in contact with the hip at the same horizontal angle as the hip and the ridge.

56. Cripple rafters. — In finding the length of the *cripple rafters* of a rectangular roof, in which a hip and the valley rafters are parallel, as at p , Fig. 80, the run equals the projection in the plan of the house as at r . The rafters at s are cripples, as they have a cheek cut upon each end; all of those between h and k are the same, as they do not rest upon the plate. Their length may be ascertained by shortening either or both ends the distance of J_1 , starting

from a rafter of known length, as described in the previous problem.

There is no seat cut to a cripple rafter, but instead a plumb, or ridge cut, or a cheek cut may be made at one or both ends. The cheek cuts may be found by the method used upon the jack and hip rafters.

In nailing the cripple rafters to their places, they should be raised until their top edges are in line with the center of the valley rafter against which they are fitted, as the sheeting should be cut to that point. In nailing the jacks and cripples, be sure that the hips and valleys are nailed perfectly straight, and not sprung sideways.

57. Collar beams. — The method of finding the lengths and of cutting *collar beams* is illustrated in Fig. 85. The

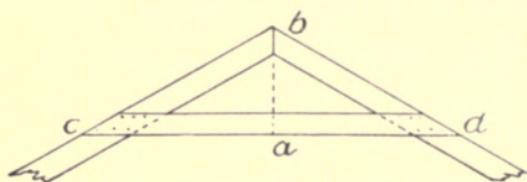

FIG. 85. — METHOD OF FINDING THE LENGTHS OF COLLAR BEAMS.

distance ab stands in the same proportion to the length of the collar or tie beam as the rise of the roof to the width of the house. Thus, if the distance ab is given,

the following mathematical formula will give the length of the collar beam.

A = distance between the bottom of the collar beam and the apex of the roof.

C_1 = length of collar beam.

C_2 = denominational constant of the pitch of the house, or 2, if half pitch ; 3, if third pitch ; and 4, if quarter pitch.

$$\text{FORMULA 26. } C_1 = A \times C_2.$$

The application of the above formula upon the steel square is as follows: using the bevel board as illustrated in Fig. 84, slip *Bl.* along the base line, *ab*, until *A* on *To.* intersects with the pitch of the roof (*cb*). The reading of $Bl. \times 2 = C_1$.

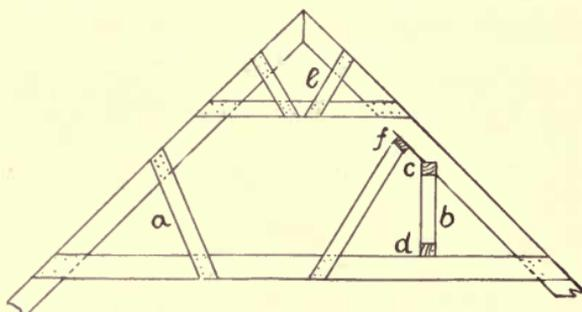

FIG. 86. — THE STRUT.

The cut of the end of the collar beam is found by placing the square as in marking the pitch of the roof (see Fig. 72). *Bl.* = end cut.

58. Struts. — The position and use of a *strut* are shown in Fig. 86 at *a* and *b*.

A strut is often used as the support for a purlin, as at *c*, in which case it is cut short enough to allow for the thickness of the purlin (*c*) which rests upon it, and of the plate (*d*) upon which it rests.

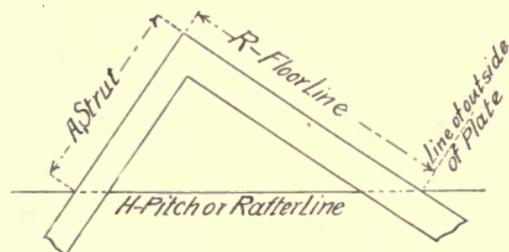

FIG. 87. — METHOD OF FINDING THE LENGTH OF A STRUT.

A strut is frequently set vertically, and used as studding for the sides of a room in the attic.

The *length of a strut* may be found upon a steel square, placed upon *H* (Fig. 87) to the constants of the rise and run of the house. Slide the square along to the given distance, *R*, upon the floor line. *R* equals the base of a right-angled triangle, of which *A* is the altitude, or length of the strut,

measuring from R to the common rafter H , the hypotenuse, or the line of the common rafter, and gives the distance of the strut from the outside of the plate. The steel square formula is as follows:—

A = length of the strut.

H = pitch of the roof.

R = distance upon the floor from the plate line.

FORMULA 27. Slide B l. on floor line to H . Reading of T o. at $H = A$.

If a strut like b , Fig. 86, is to be used, the thickness of the purlin, c , and of the plate, d , must be subtracted from A . If a strut like a is being cut, the length is usually found after the rafters and floor joists are in place; to this length must be added enough to provide nailings at each end. This latter form of strut is often used, as at e , to form a truss.

59. Purlins and hoppers.—(A.) The position and use of *purlins* are shown at c , Fig. 86. Their lengths may be found by calculations based upon the known length of the plates. If placed as shown in Fig. 86, the cuts at the angles will be square, but if set with the faces upon the same pitch as the pitch of the roof, as at f , the cut will be a hopper cut, explained later. There are several methods of finding the bevels for cutting a purlin. In the miter method, illustrated by Fig. 88, the work should be laid out upon the bevel board, and the bevels transferred with a bevel square. The following key will explain the diagram.

HH (in a) = pitch of common rafters.

A, B, C, D = section of purlin.

RR (in b) = run or plan of hip rafter, showing top view.

B = longest point of purlin.

BE (in c) = line, square with edge at B , and extending around purlin.

AE = distance from the line BE upon the top edge of purlin.

EC = distance from the line BE upon the bottom edge of purlin.

A, B, C, D (in c) = cut.

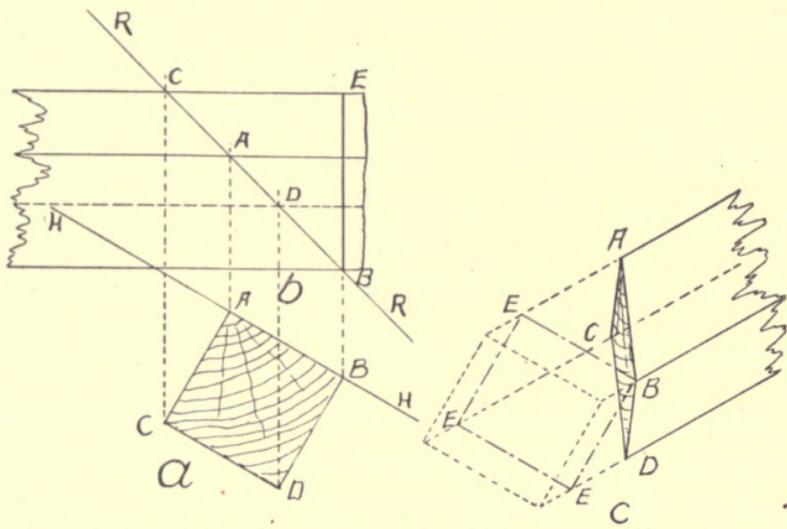

FIG. 88. — METHOD OF LAYING OUT PURLINS AND HOPPERS.

The cuts shown in c may be applied to the ends of purlins found by this method, on roofs of any pitch. For any but a square corner, it will be necessary to adapt RR to any angle of plate ; hoppers of any angle may be cut by the same method.

A purlin may be cut by using the steel square, if the method illustrated in Fig. 89 is followed. Any flare of purlin or hopper may be cut by this method. The flare of

the purlin or hopper should be laid out upon the bevel board, as shown by the diagram, which will be understood if the following key is studied.

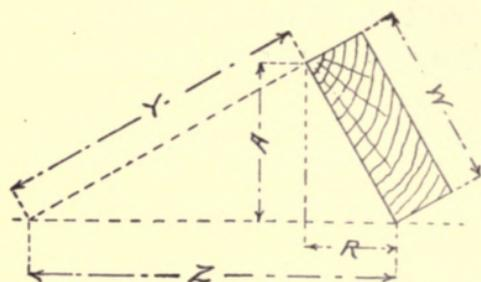

FIG. 89.—SECOND METHOD OF LAYING OUT PURLINS AND HOPPERS.

- F = face cut.
 W = width of the face.
 B = side cut or butt.
 R = run.
 A = rise.
 M = miter.

The diagram may be applied by the steel square by using the following formulas:—

FORMULA 28. $F = W$ on $Bl.$, R on $To.$ $To. = F.$

FORMULA 29. $B = Y$ on $Bl.$, R on $To.$ $To. = B.$

FORMULA 30. $M = Z$ on $Bl.$, Y on $To.$ $To. = M.$

In Fig. 90 is illustrated a simple method of laying out the cuts of a purlin, after the roof is partly constructed. The stick from which the purlin is to be cut is laid upon the outside of the rafters, as at ab , or held against them on the inside, parallel with its position when in place. The end should project over the hip rafter as at a , the extreme length of the purlin at point c , coin-

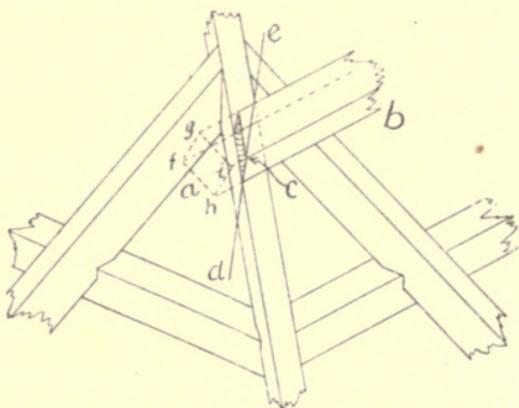

FIG. 90.—THIRD METHOD OF LAYING OUT PURLINS AND HOPPERS.

ciding with a straight edge held against the side of the hip rafter as indicated by line *de*. Draw a line by this method across the sides *fg* and *hi*, and connect them across the faces *fh* and *gi*, thus completing the lines for the cuts.

A purlin is frequently used as the top member of a truss to support a roof in the middle of the rafters, and the struts are so placed as to serve as a partition, as shown at *b*, Fig. 86.

(B.) Fig. 91 illustrates a method of laying out a hopper graphically. In this diagram, *yz* represents the bottom of the hopper; *ab*, the flare of the hopper. Continue the flare indefinitely toward *c*. From any point on *yz*, as at *d*, drop a perpendicular to *c*; with the radius, *de*, and *d* as the center, draw the arc to *f*; connect *f* and *c*; at *f* is the angle of the face or side bevel. Draw *bg* square with the flare or face of the hopper. With *d* as the center, and *dn* as radius, draw an arc to *h*. Connect *h* and *c*; at *h* is the bevel of the side or cheek cut.

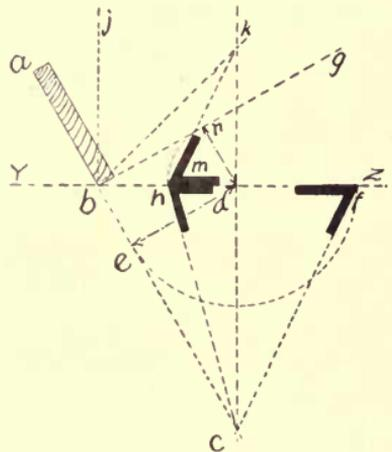

FIG. 91.—FOURTH METHOD OF LAYING OUT PURLINS AND HOPPERS.

To find the miter cut of a butt joint hopper use only the dotted lines. Erect the perpendicular *bj*, which, with the line *yz*, forms the top view of one corner of the top of the hopper which may be at any angle. Bisect this angle, and continue *cd* until it meets the bisecting line at *k*; connect *h* and *k*. The angle of the miter or cheek cut is at *m*.

60. **Octagon rafters.** — There are two ways of framing the apex of an *octagonal roof*, one of which is illustrated in Fig. 92. In this it will be seen that the rafters are framed in pairs, the first pair being cut as though they were

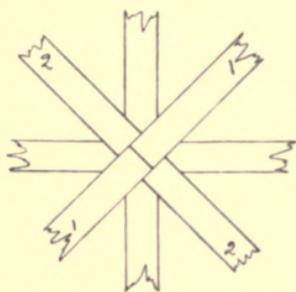

FIG. 92. — APEX OF AN OCTAGONAL ROOF.

common rafters of a rectangular roof, the run of which equals one half of the diagonal of the octagon. The following formula may be used to find the length of the first pair of rafters.

A = rise of the rafter.

R = run of the rafter.

X = bridge measure.

H = length of the rafter.

$$\text{FORMULA 31. } H = \sqrt{R^2 + A^2}.$$

To find the length of this pair of rafters by the steel square, the following formula may be applied:—

$$\text{FORMULA 32. } H = X \text{ of } R \text{ on } Bl., A \text{ on } To.$$

The length of the second pair of rafters is the same as the first, except that they are shortened at the top end by cutting a distance equal to one half of the thickness of the first pair of rafters off of the plumb or ridge cut, in the same way as common rafters are cut to fit against a ridge.

The third and the fourth pair of rafters are fitted at the top as shown in Fig. 92. The length of these rafters may be found by using the following mathematical formula:—

X = bridge measure,

H = length of the 3d and 4th pairs of hip rafters.

R = run of the hip rafters.

C = constant same as C in Formula 19.

A = rise of the hip rafters.

T = pitch line.

D = diagonal thickness of the first pair of rafters upon the line of intersection of the third and the fourth pairs.

$$\text{FORMULA 33. } H = \sqrt{R^2 + A^2} - \frac{\sqrt{D^2 + C^2}}{2}.$$

To find the length of the third and fourth pairs of rafters with the steel square, the following formula may be used:—

$$\text{FORMULA 34. } H = X \text{ of } R \text{ on } Bl., A \text{ on } To. - T \text{ of } \frac{D}{2}.$$

In order to find the side or cheek cuts of these rafters, measure back from the plumb cut a distance equal to one half of the thickness of the rafter, and work to the middle or the top of the plumb cut, as shown in Fig. 92. This involves the principle illustrated in Fig. 79.

61. Hexagonal rafters.— In cutting the rafters for a *hexagonal roof*, the same formulas and methods may be used as described in the previous topic. The first pair of rafters may be cut the same as a pair of common rafters of the same dimensions; but the cheek cuts of the second and third pairs may be made as illustrated in Fig. 93.

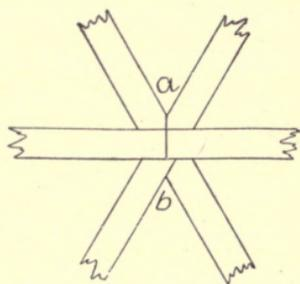

FIG. 93. — APEX OF A HEXAGONAL ROOF.

Notice that if the rafters are placed as shown at *a*, the cheek cut upon one side of the rafter will be larger than that upon the other. Many workmen prefer to cut a rafter of the sort at *b*, where it will be seen that one rafter has but one cheek cut, which brings equal cheek cuts upon the other rafter.

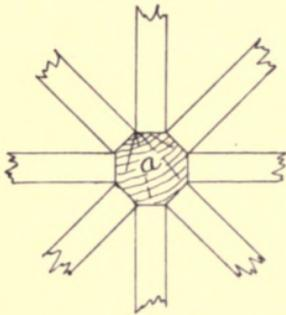

FIG. 94. — A KING-POST ROOF.

62. **The king-post roof.** — Another method of framing a *pyramidal*, or *circular roof*, known as the “king-post method,” is shown in Fig. 94. This is preferred by many workmen, as all of the rafters may be cut alike, and as all common rafters, and the king-post, *a*, may be extended indefinitely above the roof as a support to a *finial*, or ornamental finish for the peak of the roof. (*a*, Fig. 95.) This shows a finial made as part of the king-post, a common method where a piece of wood suitable for turned work can be obtained. It can be extended also below the roof, as at *b*, if the connection of the rafters at the peak needs strengthening. This is generally advisable if the roof is of half pitch, or less.

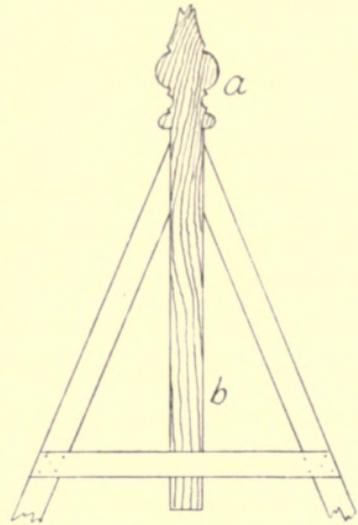

FIG. 95. — A KING-POST AND FINIAL.

63. **Backing an octagon hip rafter.** — The *backing* of the *hip rafters* of polygonal roofs may be obtained by using the following formulas : —

B = backing.

R = $\frac{1}{2}$ width of the house between parallel sides.

A = rise of the roof.

For an octagonal roof : —

$$\text{FORMULA 35. } B = \frac{A}{4} \text{ on } To., R \text{ on } Bl. \quad To. = B.$$

For a hexagonal roof : —

$$\text{FORMULA 36. } B = \frac{A}{3} \text{ on } To., R \text{ on } Bl. \quad To. = B.$$

The backing frequently is omitted upon the roofs, and the hip rafters are treated as described in Topic 53, F, under the subtopic of backing.

64. Octagon cheek cuts. — In cutting the cheeks of jack rafters for a polygonal roof, the method illustrated by b , Fig. 79, should be employed. The distance ab should be measured parallel with the plumb cut, at the top of the rafter. The length of the jack rafter, found by the method described under Topic 55, Fig. 84, is shortened the distance equal to the pitch line of one half the diagonal of the thickness of the hip rafter, on the line of the intersection of the jack, as described in Topic 55. The plumb and seat cuts may be obtained from the actual rise and run.

65. Irregular roofs. — In laying out the rafters of an irregularly shaped house or one with *unequal pitches*, a plan should be drawn showing every rafter in the roof, and the angles of their intersections with the plate, hip, and valley rafters.

The lengths of all kinds of rafters and their plumb and seat cuts may be found by using the actual figures of their rise and run, unless they are of the ordinary pitches ; then

the constants for the cuts should be used, as previously described. Thus the bridge measure of the run on *Bl.* and the rise on *To.* will give the length, and the plumb and seat cuts of any rafter in any roof.

Each side of a roof of unequal pitches should be laid off with little attention to the intersection of the rafters and those of the adjoining sides. The run of each rafter may be taken from the plan, the rise of the jack and cripple rafters from the bevel board. Slide the square along the base line of the roof, as described in Topic 55, the rise of the common, hip, and valley rafters being found by the usual methods, the bridge measure giving the lengths.

The side or cheek cuts are usually confusing to the young workman who frames his first irregular roof, but if the principle illustrated by *b*, Fig. 79, is fully understood and accurately applied, there need be no trouble, as the distance *ab* will give the cheek cut of any angle of intersection, if measured square with the plumb cut. The same method may be used in cutting the rafters against a circle or any irregular shape.

It will be seen that the eaves of an uneven pitched house will not have the same projection upon all sides if the plates for both pitches are of the same height ; therefore this defect may be corrected by raising or lowering the plate upon one or the other of the sides, or by making the bird's mouth joint so that it will give the same projection upon all sides, and so that the eaves will be upon the same line all around the house. If there is not too much difference in the pitches, this is the usual method.

66. **Curb roofs** is a term applied to mansard, French, and

gambrel roofs, which have an angle in their contour above the plate of the house. This angle is formed by a curb plate which is supported by the rafters of the lower section of the roof, and which supports the rafters of the upper section. A curb plate is used also where a deck or flat section of the roof is necessary, for instance, where the hip and valley rafters meet in an awkward manner, or where other members of the roof do not intersect as they should, though a deck is often desired and planned.

67. Curvilinear hips. —

The hip rafter of a French or other curvilinear roof may be laid out as shown in Fig. 96. The outline of the common rafter is shown by *ac*, its run being *ab*. The run, *bd*, of the hip should be drawn in such a position as to receive the projection

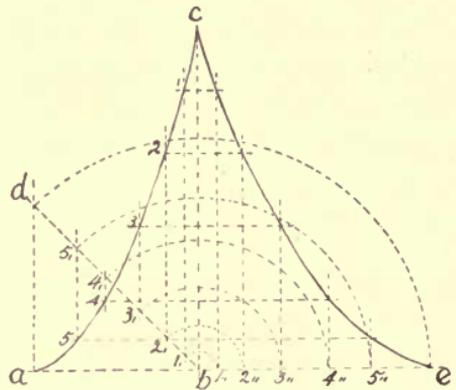

FIG. 96. — LAYING OUT A CURVILINEAR HIP RAFTER.

lines 1', 2', 3', etc.; which should be transferred to the base line, *be*, by a method similar to that indicated at *bd*. From these points 1'', 2'', 3'', etc., erect lines to intersect with horizontal lines 1, 2, 3, etc., which will give the outline of the hip rafter.

68. Flat roof.—Any roof of less rise than 1' in 9' is called a flat roof; and the same methods of finding the lengths and cuts of the rafters may be used as upon a pitch roof.

69. Dormer windows are of many shapes and sizes, and are frequently used as means of decoration, being embel-

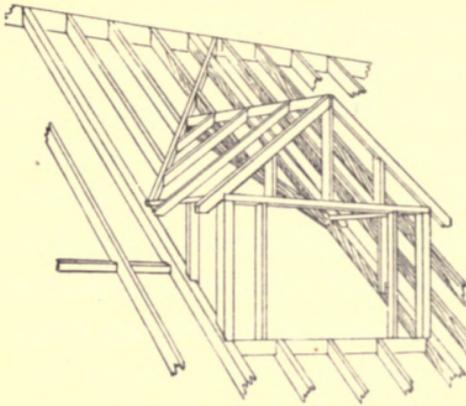

FIG. 97. — A DORMER WINDOW.

lished to a greater or less extent. They frequently form an important element in the architecture of a house.

Their construction is illustrated in Fig. 97.

A "lift" is a form of dormer window, used in places where a gable is either not desired or impracticable. It is also frequently used where economy is an important consideration, though upon the best class of work it has a good architectural character. The construction of a lift is generally similar to that shown in Fig. 98.

The finish of the dormer windows and of the lifts should be in keeping with the rest of the house; but it should be considerably lighter, being only a detail.

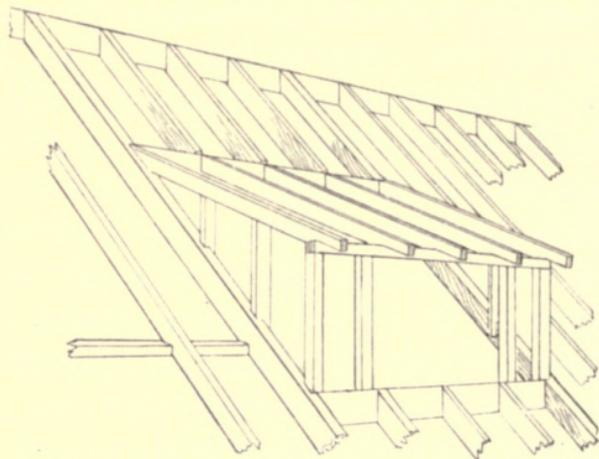

FIG. 98. — A LIFT WINDOW.

SUGGESTIVE EXERCISES

47. What is meant by the pitch of a roof? The run of a roof? The rise of a roof? What are the three pitches in common use? Do the angles of each pitch vary in different-sized houses? Prove it. Does a difference in the rise of a house affect its run? What does it affect?

Find by the use of formulas the rises of a half, a third, and a quarter pitch house, 26' wide.

48. Name and show by diagrams the different forms of roofs. What is a curb roof?

49. What shape should always be striven for in laying out a roof? Why is this advisable?

50. From what points is the length of a common rafter measured? Is the length of the rafter affected if the lookout is cut upon the lower end? Demonstrate the use of the formulas in finding the length of a common rafter. Could the dimensions of the roof be used in obtaining the cuts of the rafters? Is it a practical thing to do? What are the standard figures or constants used in laying out the cuts of the different common pitches? Should these figures be used to find the lengths of the rafters? Why? Is there any case in which they may be used for that purpose? Demonstrate the method used in obtaining these constants. Will these figures give correct results if used upon a rafter which is not square with the plate? Which edge of a rafter should generally be placed uppermost? Which part of the square should be used in measuring the run of a roof? In measuring the rise? What figure upon the blade is used in laying out all rafters which are parallel with the plate? Demonstrate by the formula the method of shortening a common rafter to allow for the ridge. Demonstrate the method of laying out the joint at the plate. What is the name of this joint? What is meant by "plumb height" at the plate? What are the sizes of rafters commonly used? How far apart are they usually placed?

51. Demonstrate from the formula the method of finding the length of a lookout.

52. What is the value of a ridge? Is it always used? What governs the length of the ridge of a gable roof? Demonstrate by the use of the formula the method of finding the length of the ridge for a half hip roof. For a full hip roof.

53. What part of a hip rafter is seen in looking at a roof plan? What is its angle with the plate, if the house is square and the pitches are equal? Between what points is the length of a hip rafter measured? What part of a right-angled triangle is the rafter? Demonstrate with a steel square the method of finding the length of the hip rafter. How should the top ends of the rafters of a perfectly square hip roof be fitted?

How much shorter should a hip rafter be cut if a ridge is used? Demonstrate the method of finding the neat length of a hip rafter by means of a steel square. How is the pitch line of $\frac{1}{2}$ of the thickness of the ridge found with the steel square? In what respect is this method of finding the length of a hip rafter similar to that of finding the length of a common rafter? What is the relation of the run of a hip rafter to that of a common rafter? Demonstrate the method of finding the constant for the run of a hip rafter. What constants are used for the rises of the hips of a half, a third, and a quarter pitch roof? Demonstrate the method of finding the plumb and seat cuts of a hip rafter by means of a steel square. How are the side or cheek cuts found? Does the pitch of a roof change the horizontal angle at which the hip intersects the ridge? Explain the principle involved in this method of finding the cheek cut, and its application to different angles of intersection. Which end of a hip rafter is usually cut first? From what point on the rafter is the length measured? Demonstrate the graphic method of laying out the bevels of a hip rafter. Describe the methods of backing hip rafters. Upon which edge of the rafter is the backing laid out? How may a roof be framed to make backing unnecessary?

54. Describe the method of finding the length of a valley rafter. How is the cheek cut found if the rafter extends to the ridge? How is the angle found for a valley rafter which fits against a hip rafter?

55. Demonstrate the method of using the steel square in finding the length of a jack rafter, if the common rafter intersects the hip at the apex. If the common rafter does not intersect the hip at its apex. Demonstrate the method of obtaining the length of jack rafters working from the lower end of the hip. What are the constants for cutting the bevels of jack rafters?

56. What is the method of finding the run of a cripple rafter? What allowance should be made in the length of a cripple rafter? Demonstrate the method of laying out the bottom and top plumb cuts of a cripple rafter. What should be the relation of the cripple rafter to the top edge of the valley rafter which it meets? What must be guarded against in nailing cripples and jacks in their places?

57. Demonstrate with the steel square the method of finding the length of collar beams. What is the purpose of a collar beam?

58. What is the purpose and position of a strut? Is it always square

with the rafters? Demonstrate the method of finding the length of a strut with the steel square. How may the formula of a common rafter be used in finding the length of a strut?

59. What are the purpose and position of a purlin? How is its length found? Illustrate a graphic method of finding the length of a purlin. Compare a purlin cut with a hopper cut. Demonstrate the method of using a steel square, to find the cuts of a purlin or a hopper. Describe a simple method of marking a purlin from a partly completed roof.

60. Describe the method of framing an octagonal roof by cutting rafters in pairs. Of framing a hexagonal roof: How can the length of the first pair of rafters be found? Of the second pair? Of the third pair? Describe the method of obtaining the cheek cuts of the third and fourth pairs.

61. Describe the method of finding the cheek cuts of the apex of rafters for a hexagonal roof.

62. Describe the king-post method of framing a polygonal or circular roof. What are its advantages?

63. Demonstrate the methods of finding the backing for a hexagonal or octagonal roof.

64. How can the cheek cuts and the lengths of jack rafters of a polygonal roof be found?

65. How may the seat and plumb cuts of any rafter be found? How may the rise and the run of any rafter be found? How can you find the length of any rafter of any pitch? Is there any difference between the methods of finding the lengths of rafters of a house of uneven pitches, and of one which has the same pitch upon each side? Describe the method of finding the side cuts of hip, jack, and valley rafters of a roof which has different pitches. Compare this principle with that of making the side cut of a jack rafter of a rectangular roof. What is the effect of unequal pitches upon the eaves? How may this be remedied?

66. Describe the methods of framing curb roofs.

67. Describe the method of laying out the hip rafter of a French roof.

68. What is the greatest pitch of a flat roof house?

69. Is a dormer window ever planned for any reason aside from light and ventilation? Describe the construction of a dormer window. What is sometimes used as a substitute for a dormer window? Compare the finish of the dormer windows with that of the rest of the house.

CHAPTER VI

BOARDING IN. OUTSIDE FINISH

70. Boarding in. — (A.) In the warmer sections of the country, the houses are built with nothing upon the outside studding except the siding, but in the North, 1" boards planed to an even thickness are nailed outside of the studding with 8d or 10d common nails. Upon the best houses these boards are often matched; in most cases they are laid as closely as possible, and covered with sheathing or building paper, which increases the warmth of the building.

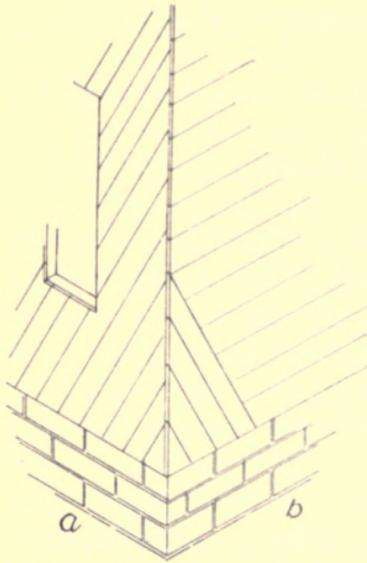

FIG. 99. — BOARDING IN.

(B.) If a heavy building is being erected, it is best to lay the boarding *diagonally*, as at *a*, Fig. 99; the frame is thereby much strengthened. For an ordinary dwelling house, unless exposed to severe winds, horizontal boarding is suf-

ficient, if the building is well braced at the corners. (See *c*, Fig. 20; *c* or *d*, Fig. 21.)

Diagonal boarding is more expensive than that laid horizontally, as a square the width of each board is

wasted, and a man can cover only about two thirds as much surface in a day.

Upon many good buildings, the corners inside of the braces are often laid diagonally, and the rest of the house horizontally. (See *b*, Fig. 99.)

(C.) In *covering* or *sheeting* the roof, matched boards are used in some localities, and are covered with sheathing paper for warmth. This is a good method in a cold climate, but as the air can reach only the part of the shingle exposed to the weather, that part will dry out, and the rest will retain its moisture. This causes one part to warp and split, and the other to decay.

In a climate where durability is a more important consideration than warmth, boards from $2\frac{1}{2}$ " to 4" in width are usually laid, for sheeting or sheathing. Between them is left a space about 2" wide, allowing the air from the house to reach the under side of the shingles; this aids materially in their drying, and prolongs the life of the roof.

71. **Cornices.** — (A.) The *cornice*, or *eave finish*, is next in order after the house is boarded in and the roof covered, as it is essential that the roofing should be laid as soon as possible, not only to protect the house, but to allow the men to work during stormy weather upon partitions, rough floors, etc.

For this work it is necessary to build a strong *scaffold* or place staging, or scaffold brackets, shown in Fig. 100. These are used by many builders in preference to a scaffold, as they

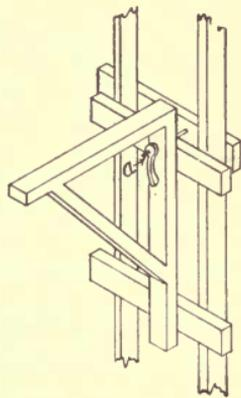

FIG. 100. — SCAFFOLD BRACKET.

may be put up and taken down with little trouble. They may be placed, as shown, before the house is boarded in, or may be fastened directly upon the boarding to allow the outside to be finished. These brackets are used quite commonly in some parts of the country, more especially in the east, where the clapboards used are made with a very thin edge, so that they may be pushed under the lower edge of the course above.

In other parts of the country, the siding is laid from the bottom; in which case it is plain the brackets are not so

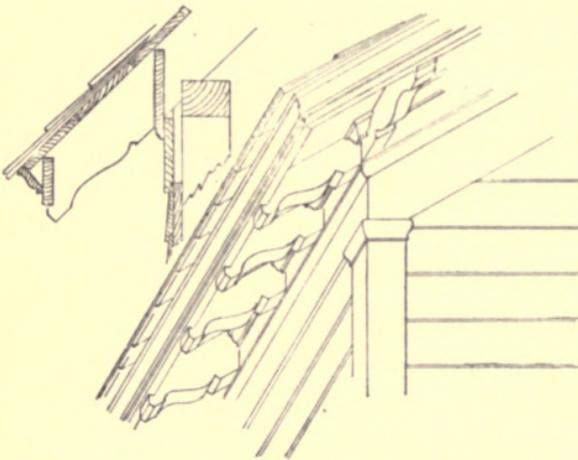

FIG. 101. — OPEN CORNICE.

desirable, since they necessitate boring a hole through the siding, as at *a*, for the bolt which holds the bracket in its place.

(B.) The *open cornice* (Fig. 101) and the *box cornice* (Fig. 102) are the types used in finishing frame buildings. They will both admit of much varia-

tion without departing from the type. The open cornice costs less than the other, but does not make so warm a house. As it projects beyond the finish of the house, the water from a leaky gutter will run outside; while, if there is a leak in the eaves of a box cornice, the water is very likely to work its way into the outside walls of the house.

If a box cornice is built, as shown at *a*, Fig. 102, with the

frieze (*b*) extending a little above the top side of the *plancer* or *soffit* (*c*) as at *z*, a space of $\frac{1}{4}$ " being left between the frieze and the soffit, any water which finds its way into the cornice will drop behind the bed mold (*d*) outside of the house. The chief objection to this is that water may stain the frieze, but it is better that this should happen than that the water should find its way inside of the house.

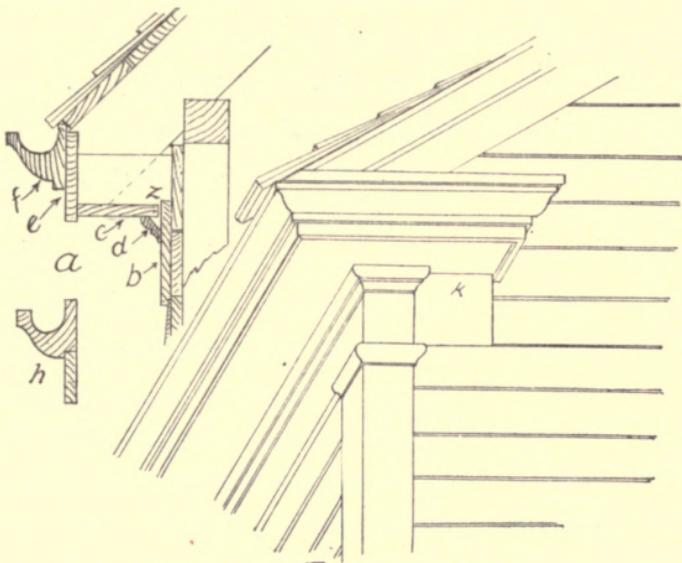

FIG. 102. — BOX CORNICE.

The *fascia* (*e*) should extend about $\frac{1}{2}$ " below the plancer. It will be noticed that the outside of the gutter (*f*) is lower than the part extending under the shingles; this allows the overflow to run over the gutter and drop clear of the house.

A box cornice does not dry out so readily as the open cornice, and therefore will need to be repaired more often.

There are several forms of *gutters* and *eaves* illustrated in Fig. 103, besides that of Fig. 102, all of which should

have a pitch of at least 1" in 20' toward the outlet. The forms shown at *a* and *b* are used commonly upon ordinary buildings; the sheet metal lining of *b* should extend under the second course of shingles above the gutter. The form

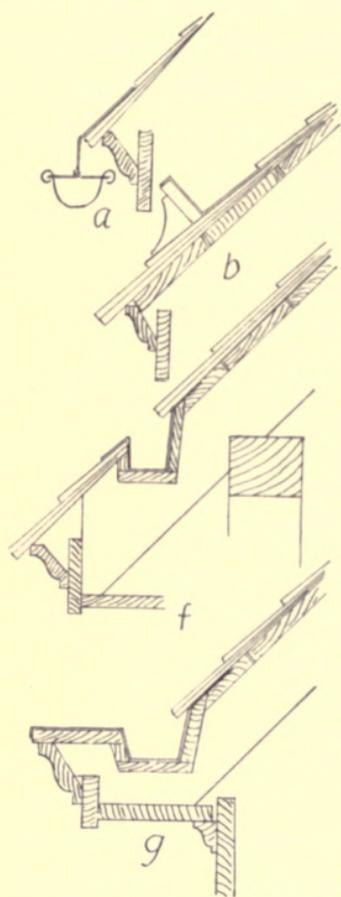

FIG. 103. — EAVES TROUGHS OR GUTTERS.

of gutter shown at Fig. 102 is an old one, still largely used upon the best residences. This gutter, which should be made of cypress, is sometimes put up as shown at *h*, in Fig. 102. In Fig. 103, *f* is frequently used upon dwellings. *G* is the type of gutter used upon large buildings, as it can be more easily repaired than any of the other forms; its pitch can be obtained without showing at the eaves, and it provides a place from which small repairs upon the roof can be made without building a scaffold.

Upon the best class of work, every joint of a wooden cornice or gutter, should be thoroughly doped with white lead or thick paint, as the cornice is difficult to repair and the use of lead will prolong its life.

The joints in the moldings of the cornice and whatever splicings are necessary, should not be made with a square butt, but should be mitered as shown in Fig. 104. This rule applies to all moldings and other finish which are lengthened. Great care must be used to make all joints in

the least conspicuous places and to face the miter in such a direction as to prevent the prevailing winds from driving into the joint, and water from running into it.

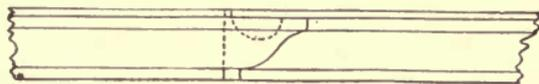

FIG. 104. — LENGTHENING MOLDINGS.

72. Gable finish. —

Gable finish should cor-

respond with that of the sides of the house in all of its details; and if a box cornice is to be returned upon the gable, the return should be the same as the projection upon the sides, as at *k* in Fig. 102. The peak of the gable is a suitable place for ornamentation, but, while a simple design often may be desirable, much of the decoration which is made there is not artistic. It is impossible for many workmen to realize that expensive elaboration is not so pleasing to the cultured taste as a simple, dignified design.

73. Outside finish. — (A.) The *lumber used for outside finish* should be selected for its ability to stand the weather and to hold its shape. Only well-seasoned wood should be used. The most satisfactory kinds are white pine, cypress, redwood, and poplar. Though the last does not stand so well as the others, yet, if kept painted, it will give good satisfaction.

(B.) *Accuracy* is needed in putting on the outside finish; the joints should be perfectly square; the time spent in securing plumb and level, framing and finish will be more than compensated for, because the work of finishing down the outside then can be done to marks made by a try-square, instead of scribing or using a bevel, and the use of the block-plane will be reduced to a minimum. For the same

reasons the door and window frames should be squared carefully and set perfectly plumb.

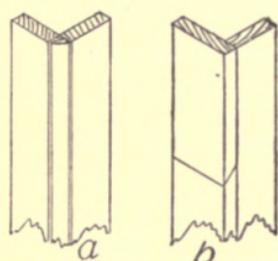

FIG. 105. — CORNER BOARDS.

(C.) The narrower the corner boards and the door and window casings, the less chance there is of their shrinking and opening the joints at the end of the siding, and unless a quarter round is used in the corner, as shown at *a*, Fig. 105, the lap of the corner board at *b* should be made upon the side where it will be the least conspicuous.

Joints made in splicing corner boards should be made as shown at *b*, Fig. 105, and doped to prevent the rain from driving into the splice.

Corner boards are usually 4" wide, though they may be of any width to suit the fancy of the builder or architect, provided that a nailing for the ends of the siding is secured upon a stud. Siding, when mitered at the corners, as shown at *a*, Fig. 106, shows no corner boards, and gives but one joint through which the

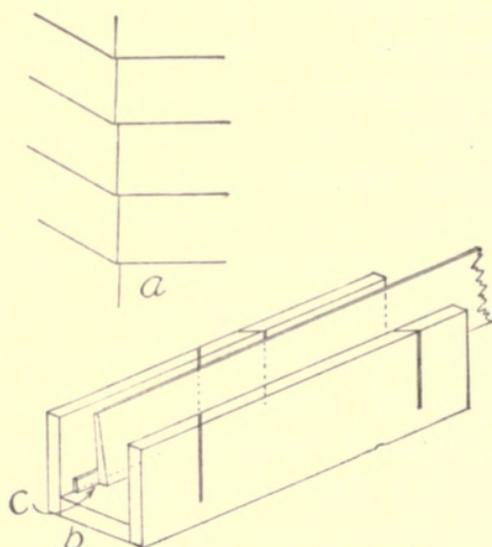

FIG. 106. — MITERED CLAPBOARDS.

weather may find access to the house. In making this sort of corner finish the miter box is used, as shown at *b*. The distance between the back of the box and the

back of the clapboard or siding, at *c*, should be the same as it will be when it is in place. Care should be used that the clapboard is not sprung in the sawing.

(D.) Sheathing paper usually is laid under the siding of a well-built house, and its use always should be encouraged, especially in the colder parts of the country, as nothing else costing as little adds so much to the warmth of the building. It should be laid under the corner boards, casings, frieze, and water table, and should project several inches on the boarding, so that the paper which is laid under the siding will lap over and make a tight joint.

(E.) Fig. 107 shows a few of the different forms of siding. It is largely a matter of preference, which form is the best,

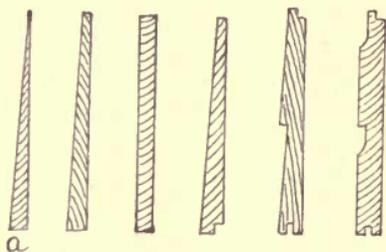

FIG. 107. — FORMS OF SIDING.

though the matched forms are the warmest. *A* is the form largely used in New England; it is laid from the top, the lower courses being pushed under the upper. In laying this form of siding, the scaffolding may be taken down as soon as the siding has been finished and has received the first, or priming coat of paint; thus when the house is sided the scaffolding is out of the way, and the house has been primed. As the chalk lines will not be covered up, a number may be made at once; this is an advantage over making a line for each course as it is laid, which is necessary if the siding is laid from the bottom.

In finding how much each piece of siding is to be exposed to the weather, it is the usual custom to estimate the exact height which the siding is to cover, and divide it by

$4\frac{1}{2}$ " , or the desired exposure, thus allowing the difference to be distributed throughout the entire height, instead of in the last few courses. This method is not used upon matched siding, as the width of that is fixed, and with the exception of a little variation upon the last few courses it is carried up the width of the boards.

Beveled siding usually is laid from $4''$ to $4\frac{1}{2}''$ to the weather; the exact distance being found by the above method, and laid out upon the corner boards, or casings of the opening.

As beveled siding is laid from the bottom, it is laid to a chalk line upon the course below a straightened edge, or a siding gauge is often used to assist in keeping the courses above parallel.

All joints in the siding and other vertical square joints, should be cut a little under, not enough to be seen, but to insure that the joint is perfectly tight upon the outside.

(F.) It was the custom formerly to lead every joint of the outside finish of a house, but this is one of the good habits of our forefathers which we have allowed to fall into disuse. While it adds to the expense of the labor upon a house, it also adds much to its durability.

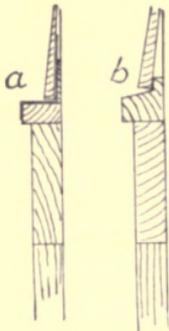

FIG. 108. — FLASHING OVER OPENINGS.

(G.) The *joints* between the tops of all openings and the siding should be flashed with tin, zinc, lead, or copper, as shown at *a*, Fig. 108. A cap with a wash rabbet is often preferred. (See *b*.)

(H.) If *shingles* are used for siding, they are laid from $5''$ to $6''$ to the weather. There is much to be said in their

favor, as they are cheaper, warmer, and more easily kept in repair, and the side walls may be boarded in with sheeting, like the roof, with a space between boards. Besides these advantages, shingles may be stained, a process cheaper than painting, and more artistic; the shingles may be arranged in designs to assist the general effect of the house.

(I.) The *water table*, or base, Fig. 109, generally is used upon all but the cheapest houses, as it gives a finished appearance to the lower part of the building, besides allowing the drip, from the sides of the house, to fall clear of the foundation, over which it would otherwise wash, depositing the accumulated dirt.

74. Conductors. — *Conductors*, or *down-spouts*, are made of round, or corrugated, galvanized iron, and are held in their places by brackets adapted to the shape of the conductor. The corrugated spouts are better, for if they become clogged with leaves, and water freezes in them, they will expand and not break, as the round ones will.

75. Finials. — *Finials* made of sheet metal are used as an ornament to finish the peaks of gables, turret roofs, etc. They may be made of almost any design; but as they are kept in stock in many different forms and sizes by different manufacturers, it is rarely necessary to design a special form.

Wooden finials are used a great deal in certain localities, and if kept well painted are satisfactory. They are sometimes made as part of a king-post for a turret roof, as shown in Fig. 95.

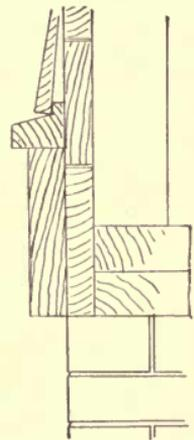

FIG. 109. — WATER TABLE.

76. Circular gutters.—*Circular gutters* and moldings may be made by three different methods, one of which, and perhaps the most common, is to saw a plank of the right thickness to the desired sweep, and work the molding around it. This is done usually at the planing mill,

but the objection to this method is that the pieces upon ordinary towers are very short, and as they are cut out of wide plank there is considerable waste of material.

If this method is used, the joints must be doped, and the work well painted. Only thoroughly seasoned stock should be used upon this kind of work, as in seasoning the sweep will change, and the molding may check badly.

Another way of treating moldings which have to be carried around curves of any common radius is to select enough straight-grained, perfect pieces of molding to reach the entire distance twice, with allowance for waste. These should be taken to a mill and cut with a sharp, smooth-cutting circular saw, as shown in

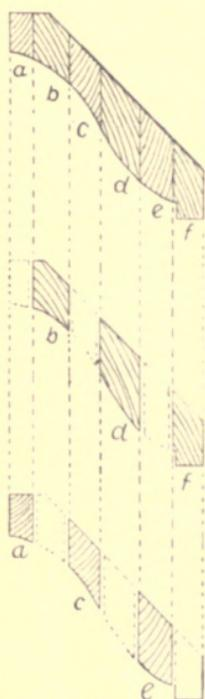

FIG. 110.—CURVED MOLDINGS.

Fig. 110, alternating the cuts in the different pieces, in order to replace the saw cut, so that when the work is done there will be one piece of molding sawed into thin strips which will bend around any ordinary sweep, as the pieces may be sawed to any thickness. They are then put into place upon the building, each piece being nailed upon the one under it and each joint plentifully doped with white lead.

If this is done accurately and the work well smoothed and painted, it is difficult to discover from the ground how the work was done.

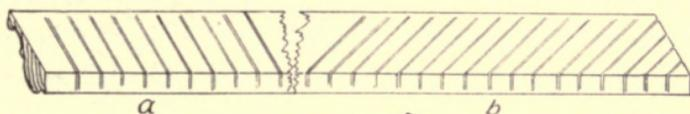
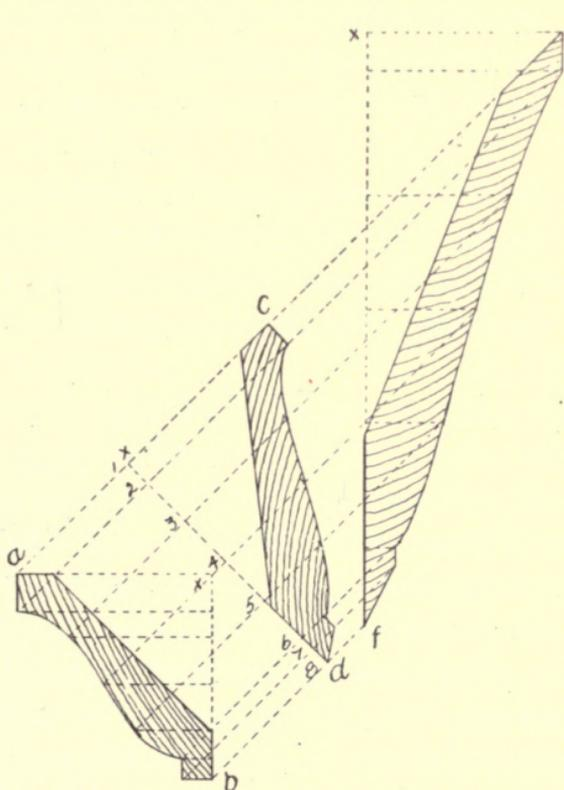

FIG. 111. — SCARFING A MOLDING FOR BENDING.

Another method, adaptable to small moldings, is to saw into them, as in Fig. 111 (see Topic 22, A, of "Inside Finishing"), though this method is not recommended upon work which is to be exposed to the weather, as there is so



much short wood between the cuts that may drop out after the work has been in place a few years. The cuts may be made either square, as at *a*, or at an angle, as at *b*; if made in the latter way, the wood will bend more evenly.

77. Rake moldings.

— (A). The method of finding the shape of *rake moldings* is illustrated in Fig. 112, all of the moldings but the regular patterns being worked out by

FIG. 112. — LAYING OUT A RAKE MOLDING.

hand if there is no mill conveniently located where cutters may do it, though even then it is often more economical to work the molding out on the bench if properly shaped molding planes are available. Worked rake moldings are not used so much to-day as they were formerly, as upon common buildings the eaves are so designed as to make them unnecessary.

The molding *ab* governs the shape of the others, and is used upon the level eaves; it should be drawn at the angle at which it will rest in relation to the level, and working lines should be drawn from it, at the pitch of the gable. The molding *cd* is the pattern used upon the gables, or the pitch of the roof. The molding *ef* is to be used upon the finish of the upper edge of a shed roof, though this form of rake molding is rare.

The lines, 1, 2, 3, etc., are for the purpose of determining the points which give the contour of the moldings, and in every case they are the same distance from the back line, *xd*, and *xf*, as from the line *xb*.

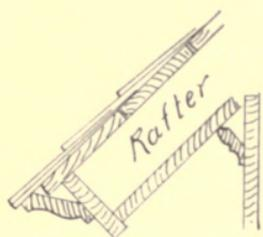

FIG. 113. — RAKE BOX CORNICE.

The rake cornice and molding upon a moderately expensive house are often put on as shown in Fig. 113, the ends of the rafters being square with the pitch of the roof, and the fascia mitered around it, upon which the molding is nailed. By many carpenters this method is considered neither architectural nor workmanlike; it certainly permits quite a saving in labor, and aside from appearances is quite as efficient; it is used upon many good buildings.

(B.) The method of making a miter box for the sawing of rake moldings is shown in Fig. 114, in which c, a, b , of A shows the plan of the house, and ad the miter of the molding; the diagram, a_1, b_1, c_1, d_1 , shows the method of finding the miter if the building is not rectangular in plan. B shows the pitch of the roof, and baz the plumb cut of the mitered corner, which is the same as that for common rafters. C shows the top view of the miter box, the angle bad of which equals the angle bad of A , according to the angle of the corner of the house. A line, squared across the miter box from d , gives x ; for a square house, ax will equal the width of the box.

D shows the edge view of the miter box, the angle baz of which equals the angle baz of B . Draw the line ax , of C , square with az and line xy , parallel with line az , and therefore square with line ax .

E shows the angle which is the miter of the rake molding, in order to obtain which, ay , of D , is laid off upon box E , and a line squared across the box as at wy ; by connecting a and w , we have the miter. Thus, za of D , and aw of E , will give the down or plumb cut and miter of

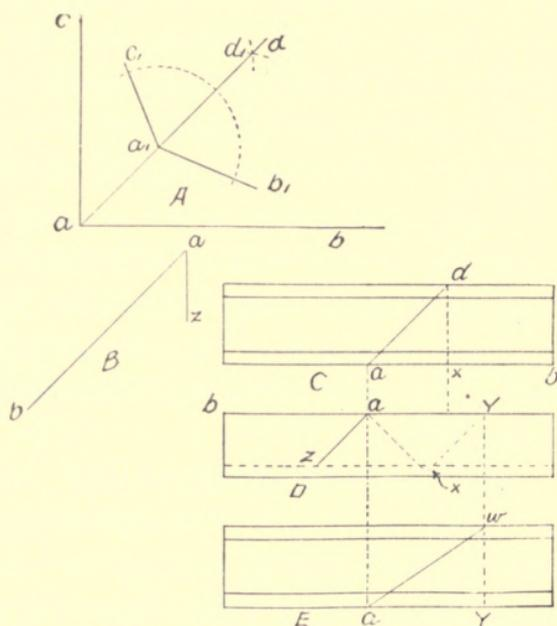

FIG. 114. — RAKE MITER BOX.

the gable piece of the rake molding; the horizontal, or eaves piece being cut in the miter box to the angles shown in *bad* of *A*. For a square corner this latter cut may be made in a common miter box. It is not necessary to make a separate box for each cut, as one box three or four feet long will be ample for any job of cornicing. For cutting the rake miter of the other end of the eaves, the cuts should be made the other way, or the molding cut the other side up, though unless great care is used this method is apt to give unsatisfactory results.

Some mechanics make a deep box with the ordinary miter cuts, and hold the rake moldings at their angles when in position, as the horizontal angle of each miter joint is always the same upon corners of the same horizontal plan or angle.

78. Siding a circular tower. — In *siding a circular tower* with beveled siding, it will be found necessary to cut the lower edge of each piece to such a form that when it is in place it will be parallel with the line of the water table.

Let *abc* (Fig. 115) represent the section of a piece of siding. Place it with its back at the angle it will assume when in position upon the house.

The distance *be* equals one half of the width of the tower, or the radius of its plan,

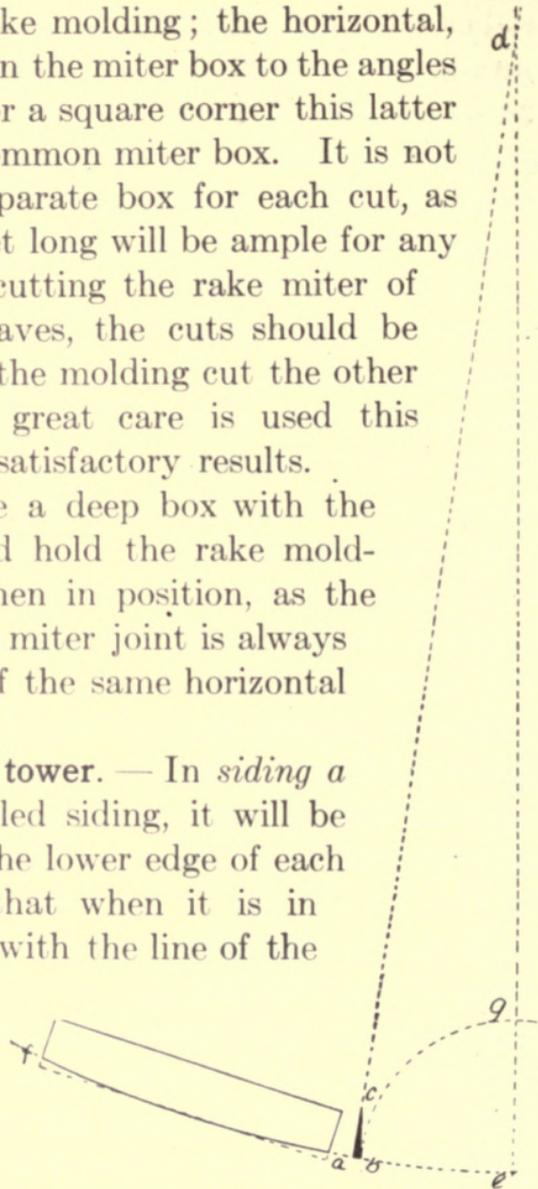

FIG. 115. — SIDING A CIRCULAR TOWER.

indicated by the arc bg . Erect a perpendicular of indefinite length from e , and continue the line ac , or the face of the siding, until it intersects the perpendicular from e at d . With d as the center, and db as the radius, describe the arc ef . If the bottom edge of each piece of the siding is cut to this arc, there will be no trouble in fitting it around the tower, unless the circle is so small that the material will not bend.

Clapboards should be bent dry, if possible; if they are soaked in hot water, they will bend more easily. Cold water is generally used, as hot water is not always available.

79. Scribing. — *Scribing* is the term applied to the process of fitting wood to the irregularities of any uneven surface, as, for instance, in fitting a piece of ceiling against a stone wall, as in Fig. 116. Here it is necessary that the tongue edge of the piece of ceiling should stand plumb, resting at one or more places as at a , as it is to be the first board of a ceiling partition. Dividers should be used to transfer the irregularities of the stone wall to the piece of ceiling. First, fasten the ceiling firmly in the place as indicated, and set the compasses at the greatest distance between the stone wall and the edge of the ceiling, as at b . In making the mark, or scratch, f , the points of the compasses should be carried perfectly level, or square with the edge of the ceiling; to insure accuracy the greatest depressions and angles, as at c , should be transferred to the ceiling by means of a try-square.

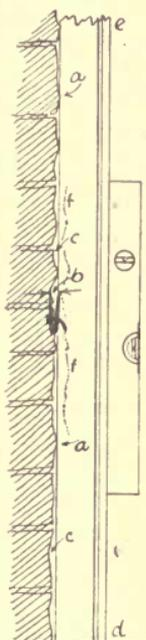

FIG. 116. —
SCRIBING.

Some workmen prefer a pair of scribing dividers which have very stiff legs and a pencil attachment that makes a mark which may be more easily followed in cutting than one made with the legs of a compass.

The cut should always be made so that the joint will fit on the face; therefore the face of the piece being marked, the wood in its thickness should be cut far enough back

to insure that it will not prevent the piece from making a joint on the face.

This process is useful in fitting against moldings, finish, floors, or in any place where a joint, not perfectly straight, is necessary.

80. Dome roof.—In boarding a dome roof, it is the usual custom to lay the boards vertically, as shown in Fig. 117, as it is more economical than to cover it

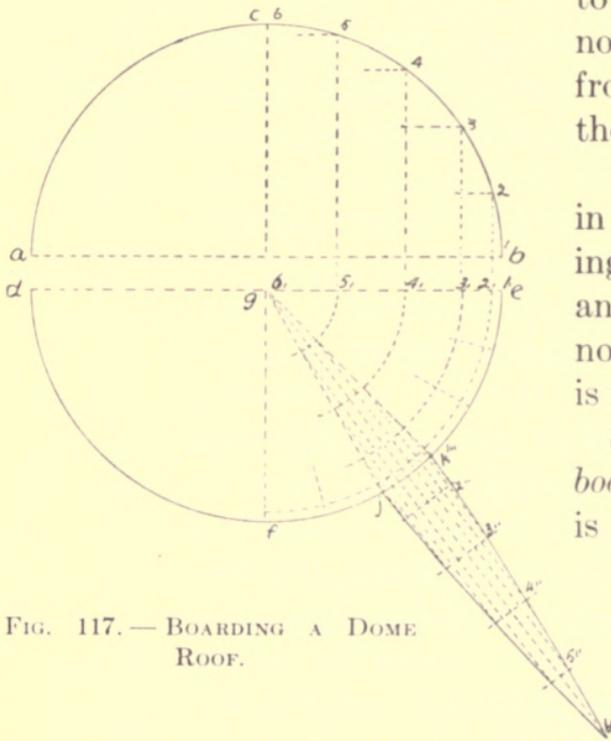

FIG. 117. — BOARDING A DOME ROOF.

horizontally, since by the latter method each course of boards has to be cut to a different sweep, causing a great waste of material, and since it is difficult to bend the boards to the shape of the roof as the top is approached, unless boards are used which are too thin to hold the nails by which the roofing is fastened on.

In laying out the boarding for a dome roof vertically, the elevation of the dome, acb , should be drawn, and points 1, 2, 3, etc., marked at any convenient distance upon the surface of the dome. These points should be projected to the diameter of the semi-circular plane de , and one quarter of the circle ef , divided into any number of equal parts, say six, denoting the width of the boards at the base of the dome. Connect two adjacent points, as j, k , with g by straight lines. Draw an indefinite center line between j and k , from g toward b'' ; space from jk , toward b'' the distances 1, 2, 3, etc., of the elevation, and mark them $1''$, $2''$, $3''$, etc.; upon these lay off the corresponding distances from arcs $1', 2', 3'$, etc., working from the center line. Connect b'' with j and k , by a curved line drawn through these points; this gives the shape of the roofing boards, of which there will have to be four times as many as were laid off in the quarter from which the drafting has been done.

Upon full-sized work, this curve should be marked by a batten, a thin piece of wood which will bend easily. The method described above is sufficiently accurate for practical purposes, but, as the length of the boards will be a little more than the result obtained, the butt or wide end of the board should not be cut to its neat length until it has been tried in its place and the length accurately marked. This is necessary on account of the rise in the surface of the dome between the points 1, 2, 3, etc. The edges of the boards should be cut under enough to allow them to come to a joint upon the surface.

SUGGESTIVE EXERCISES

70. What is the difference in the methods of finishing the walls of a house in the colder Northern States, and in the South? How should a heavy building be boarded in? What is a safe method of boarding in an ordinary house? Which is the more expensive method of boarding in? Why? How may the braced corners of a house be boarded to add to the strength of the house? What is the warmest way to sheet a roof? What is the objection to it in a damp climate? Describe a method better suited to a warm climate. Compare the two methods.

71. Describe an open cornice. The box cornice. Which is the cheaper form? Compare the two for warmth and durability. Describe different forms of eaves troughs. What should be the pitch of a gutter to allow the water to run off easily? How should the joints of a gutter be treated?

72. What should be the relation between the finish of the gable and that of the sides? How may the gables be treated to add to the appearance of the house? What should be guarded against in designing the ornamentation of the gables?

73. What should be the qualities of lumber suitable for outside finish? Name several woods. What is the most important thing to do after a house is boarded in? What has to be done before the roof can be put on? Why should a house be covered as soon as possible? Why is it economy to spend time in securing accuracy in the framing of a building, and in putting on the casings and corner boards? What is the advantage of narrow corner boards and casings? Where two boards are lapped together, is there any preference as to which side the lap should come upon? How should a joint be cut to insure a perfect fit upon the face? Should moldings and butt joints in the finish be made square? Is it best to put anything upon the joints? Is it the common practice? How much is siding usually laid to the weather? Describe the different forms of siding commonly used. Compare the methods of siding generally used in the east and in the west. What is gained by the use of sheathing paper? How is it put under corner boards and other finish?

74. How are conductors usually made? Which is the best form? Why?

75. For what are finials used? How are they generally made? How is a wooden finial sometimes used in framing a tower roof?

76. Describe the method of getting curved moldings out of plank. What is the objection to this method? Describe two other methods of getting out sweeps. Compare the three.

77. Describe the method of finding the shape of rake moldings. How are they usually made? Describe a miter box for making the cuts for a rake molding. How may a roof be finished without using a rake molding?

78. Can straight siding be laid upon a circular tower? Describe the method of finding the sweep of the lower edge.

79. What is meant by "scribing"? In fitting a piece of ceiling against a rough brick wall, what is the first step? At what place should the dividers be set? How should prominent points be marked upon the ceiling? What tool is preferred for scribing by many workmen to a pair of common dividers?

80. Describe the method of boarding a circular dome roof.

CHAPTER VII

ROOF COVERINGS

81. Shingles. — (A.) In *shingling a roof*, the shingles should be laid from 4'' to 5'' to the weather; the steeper the pitch, the greater the exposure which may be allowed. A quarter pitch roof should be laid with an exposure of from 4'' to 4 $\frac{1}{4}$ '' to the weather; a third pitch from 4 $\frac{1}{4}$ ''

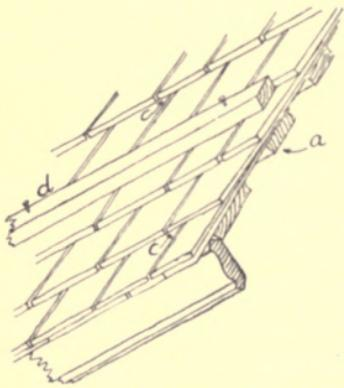

FIG. 118. — SHINGLING
A ROOF.

to 4 $\frac{1}{2}$ ''; and a half pitch roof from 4 $\frac{1}{2}$ '' and 4 $\frac{3}{4}$ '' . The distance should in no case be more than 5'', as each shingle should lap over the two courses below it, as at *a*, Fig. 118, and at *w*, Fig. 119. A 16'' shingle would not permit this if more than a 5'' lap were allowed.

It is necessary that the finish of the eaves, or the outside members of the cornice, should be in place before the lowest course of shingles is laid. This course should be laid double, as shown. This is done by fastening a shingle at each end of the roof, and tacking one every eight or ten feet, with the desired projection, generally about 1 $\frac{1}{2}$ '' . A chalk line is then stretched, supported by these shingles, and the lower course laid to it. The joints of all courses should

be broken at least $\frac{3}{4}$ ". By this is meant that the joint of the upper course should be at least $\frac{3}{4}$ " from the nearest one of the course below, as at *c*, Fig. 118. It is good practice to break the joints of two courses as far as possible. A shingle over 8" wide should be divided in the middle, and laid as two shingles, or it may split over the joint of the course below after it has been exposed to the weather.

Two 4*d.* nails should be used in each shingle, and should be put in not less than 9" or 10" from the butt, or thick end, for if a joint or a nail hole in a shingle comes over a nail in the course below, rust may cause a leak here before the roof needs repairing elsewhere. Such a leak will be difficult to locate.

If the shingles are very dry they should be wet thoroughly before laying, or laid with the joint at least $\frac{1}{8}$ " open; otherwise they will buckle and split when wet by the rain.

If the best results are desired, the shingles should be nailed with cut nails, which do not rust out so quickly as wire nails; unless used in a damp locality the wire nails prove satisfactory.

There are two methods of shingling above the lowest course; one is to tack a straight edge to the course below, and lay the next course against it, as shown at *d*, Fig. 118.

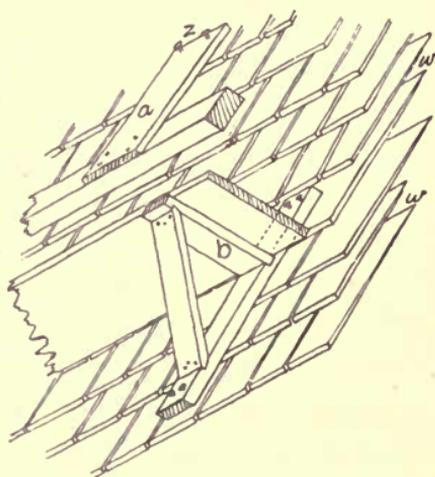

FIG. 119.—SCAFFOLDS FOR SHINGLING.

A number of shingles may then be laid upon the roof and nailed rapidly.

Another way, which is preferred by many, is to make a chalk line mark; by this method, as the shingles are laid one at a time, two courses may be carried along together.

Care must be used that the joints between the shingles be kept square with the eaves; if the butts are not square, the worst of them should be made so with a saw.

The scaffolding for finishing down the outside and putting on the cornice should be put up to prepare for shingling, as it may be used to advantage in laying the lower courses, and in working around the roof.

Some workmen lay the lower courses from above, and in repair work it is often better to do this, than to go to the expense of a staging or scaffolding.

There are numerous devices for shingling-scaffolds, or supports upon the roof, two of which are shown in Fig. 119. That shown at *a* is a very simple device, being nothing but a piece of 2" \times 4", with pieces of board about 20" long nailed upon it about six feet apart, through the upper end of which, at *z*, a couple of nails are tacked into the roof. Shingles are used by some workmen for this purpose, in place of the 20" boards. This form is preferred by many to the more elaborate bracket shown at *b*. Several of these are placed at convenient distances, and a board laid across them, providing a much safer foothold than does the one above described.

(B.) We will discuss *three methods of shingling hips*. Tin shingles are used in two ways, as shown in Fig. 120, *a* and *b*. In nailing the hip shingles laid by either of the

two methods, it is necessary that nails should be driven near the points to resist the tendency to warp.

Tin shingles should correspond in shape to that of hip shingles; they should be at least 7" wide, and long enough to reach well under the tin shingles of the course above, as at *w*. At *a*, the tin shingles are laid so that the lower end will just be covered by the hip shingle of the course above; this method is not so serviceable as that illustrated at *b*, as the short grain of the hip shingles at *z* will in time split off, and the hip be destroyed, though the former makes the better-looking hip when first laid. In *b*, the tin shingles are laid over the hip shingles, flush with the lower edge of each course; this protects the short grain, and is a very satisfactory way of finishing a hip. In all cases, care should be used that the line of the hip is kept perfectly straight from the eaves to the peak. Some workmen make their tin shingles long enough to allow the bottom end to be turned down the thickness of the butt of the hip shingle, and drive nails through the tin into the butt. This holds the lower end of the tin shingle without any nails directly through it, which should be avoided if possible, as the action of the weather is apt to make

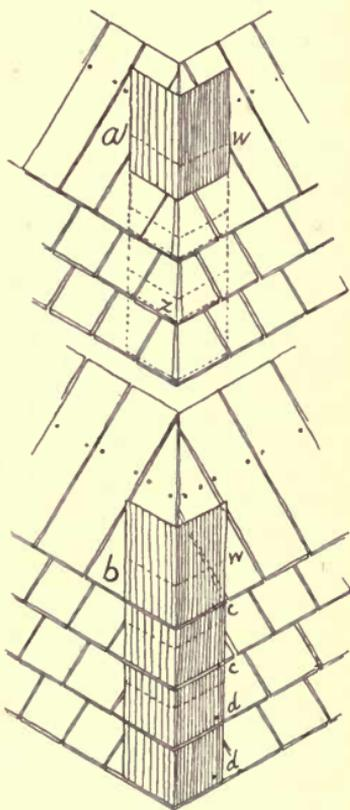

FIG. 120. — HIP SHINGLING;
METHODS 1 AND 2.

a leak where a nail is unprotected. The top end of the tin shingle should be held by driving nails where they will be covered by the hip shingle of the course above.

In Fig. 121 is shown the third method of hip shingling, the short grain of the above methods being done away with. The tin shingle *z* may be cut square upon both ends and laid under the hip shingle out of sight, as at *a*, the hip

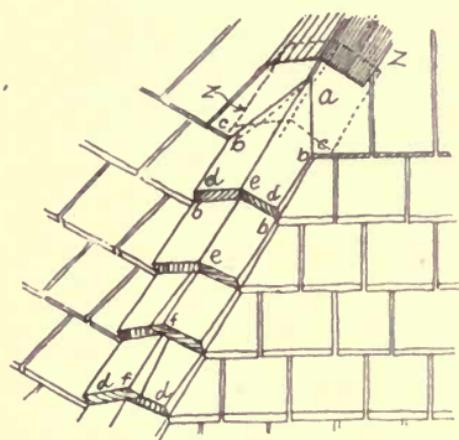

FIG. 121. — HIP SHINGLING;
METHOD 3.

shingles forming a row of raised shingles along the hip. In this case, the hip shingles may, if necessary to hold them down, be nailed at the butt end, *d*, as the upper end of the "sight" at *b*, or that part of the shingle "to the weather," is not so thick as the lower end of the course it fits against, as at *c*, which may leave a space between the back side of the hip shingle, *d*, and the face side of *b*, unless the upper shingle is nailed down to a joint. This should be avoided if possible, and the nails driven where the hip shingle of the next course will cover them. In most cases these nails will be sufficient.

The hip joint may be mitered, as at *e*, or lapped, as at *f*.

The hip is less apt to leak than any other place upon the roof, as the water runs away from it; but since it is so prominent, the work should be well done, and all lines from the ridge to the eaves should be straight and parallel.

(C.) In *valley shingling*, a strip of tin, lead, zinc, or copper 20'' wide should be laid in the valley, as at *a*, Fig. 122, and nailed only at the extreme edges. The best shingles should be laid in a valley, allowing a wash of at least 6'', as at *b*, except in the valleys of small roofs, dormer windows, etc., which may have sheet metal 16'' wide, and a wash of 4½''.

Shingles should not be laid in a valley beyond the place where those of the course above will meet them; for instance, course *c* need not be continued beyond *d*, where it meets the course above. This leaves a

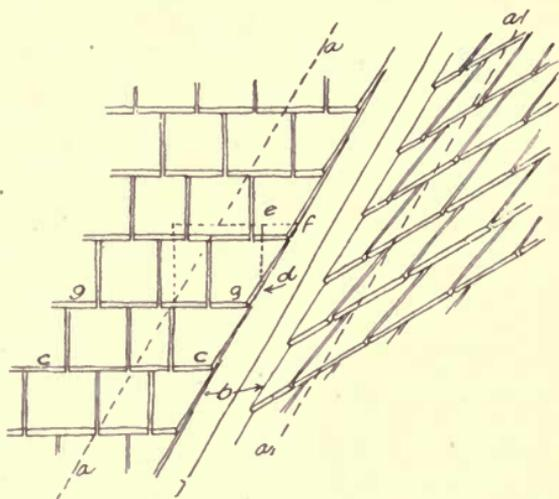

FIG. 122. — VALLEY SHINGLING.

triangular space, *def*, in which the shingles do not lie closely against the tin, but which allows the air to enter under the valley shingle of course *g*, thus assisting the shingles in drying out, and also making it unnecessary to drive nails through the tin, as would be required if the courses were carried out to the valley. The valleys usually leak before any other place in the roof, as they are apt to be more in the shade, and to have less circulation of air; the snow and leaves find lodgment there, and are often retained after the rest of the roof has dried out.

Another method is to lay the valley shingles close, using a tin shingle under each course, an application of method 1

under hip shingling. This is used by many, but it does not stand so well as a valley with a wash, as it does not dry out so readily.

(D.) In repairing a split shingle upon a roof, a tin shingle about $3\frac{1}{2}'' \times 7''$ may be pushed under the split as in Fig.

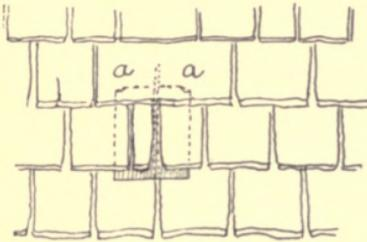

FIG. 123. — REPAIRING A SHINGLED ROOF.

123; by turning up the upper corners, as at *a*, the tin shingle will be held in its place. If there is a serious leak, the place should be reshingled; the old shingles should be torn off by means of a thin piece of steel shaped as in Fig. 124, and from 24'' to 30'' long, which may be thrust under

the shingles to cut the nails by means of the edges *b*. Unless this is done, it is difficult to stop the patch upon the upper end.

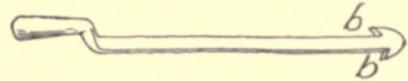

FIG. 124. — SHINGLE NAIL CUTTER.

82. Flashing. — *Flashing* is the term applied to the process of making a joint water-tight, by fitting tin, lead, zinc, or copper in

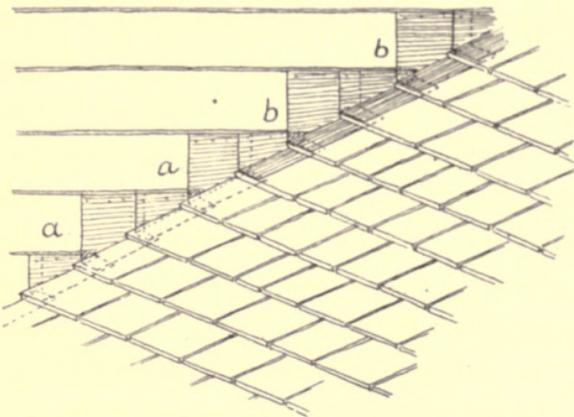

FIG. 125. — FLASHING A DORMER WINDOW.

such a way as to prevent the water from running into the joint. The flashing of slate roofs should be of copper, as the slate will, if laid properly, out-wear all other sheet metals.

Figure 125 shows two methods of *flashing around a dormer window*, or any place where shingles or clapboards join a shingle roof. At *a* the flashing runs under the roof shingles and carries the water under the course of shingles above, causing them to decay more quickly than they otherwise would, while if flashed as at *b* the water will run onto the roof and away; *a* makes the better looking job, but *b* is the more satisfactory.

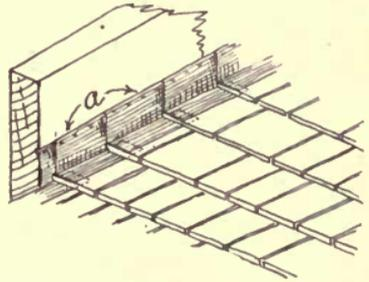

FIG. 126. — SKYLIGHT FLASHING.

For *flashing around a skylight*, or any smooth wooden work, the sheet metal should be cut into the vertical side of the joint, as shown at *a*, in Fig. 126, and the top bedded in white lead, and nailed into the cut securely. At the upper side of the frame there should be a cricket, or saddle;

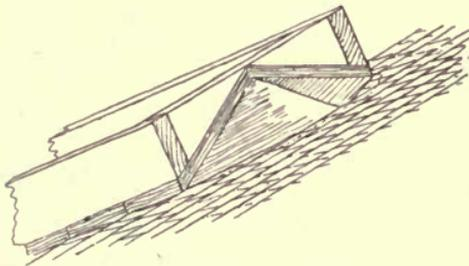

FIG. 127. — SADDLE OR CRICKET FLASHING.

this is a board, covered with sheet metal, for the purpose of shedding the water, as shown in Fig. 127. This saddle also should be placed behind chimneys, and all other places where a roof pitches toward a vertical or perpendicular surface.

A *brick chimney always should be counterflashed*, as in Fig. 128. The flashing, *a*, should be carried under the course above, and nailed well under the butt of the next course, but not nailed to the chimney at all, as there is a certain amount of shrinking and swelling of the timbers

of the house, as well as of expansion and contraction of the chimney, as it alternately heats and cools, besides the settling which always takes place in a new house. If the flashing is fastened rigidly to the chimney, a leak will probably occur sooner or later.

In putting the counter flashing, *b*, in brick work, the mortar should be raked out, and the flashing metal entered at least $\frac{3}{4}$ "

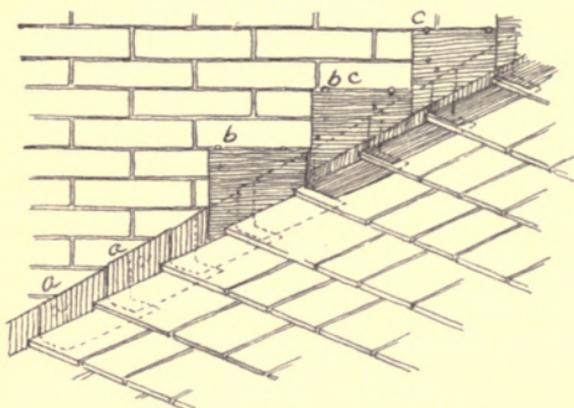

FIG. 128. — COUNTER FLASHING.

and held in place by a metal wedge, or a hook-shaped tack made especially for that purpose. A 10d. common nail is sometimes used for the same purpose, the head holding the flashing in place, after which the joint is well pointed with elastic roofing cement.

At *c* is shown a third method, with the flashing resting upon the shingles. To repair the roof, the counter flashing may be lifted up, and the flashings easily removed, while by the other methods the flashing would be destroyed.

Flashing should extend not less than 3" above the roof in its lowest place, and in a pocket or place where snow is apt to accumulate, it should be high enough to insure that there will never be any trouble. No shingles should be laid over the metal, as the nail holes will cause a leak, though the flashing should extend under the shingles to the first row of nails.

In flashing any but a very simple roof, there generally will be places where the soldering iron will have to be used, and the carpenter who neglects to have the work done properly will find that his reputation will suffer; the architect or owner may make him pay for any damage to the inside of the house resulting from a leak.

83. Metal roofs. — (A.) In recent years, *steel roofs* have come into use in different parts of the country. The standing-seam steel roof (Fig. 129, *a*) is well adapted for use upon barns and warehouses. If used upon a roof which has no long valleys, it may be laid rapidly by unskilled labor with a little oversight, and will give good satisfaction, though steel is soldered with the greatest difficulty.

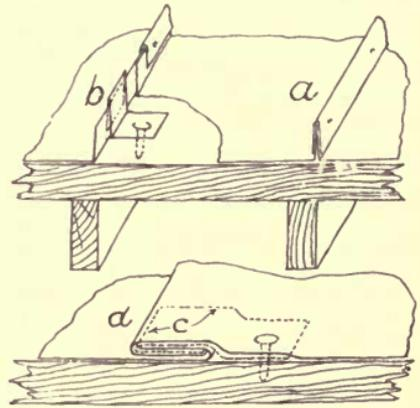

FIG. 129. — METAL ROOFS.

a, standing seam; *d*, flat seam.

Tin roofs may be laid by this method, and are to be preferred to the flat seam shown at *d*, as the roof may be repaired more easily, and expansion and contraction in different temperatures will not be so apt to break the metal.

Dealers who handle the standing seam roofing generally have a set of tools to lend with which to lay the roof. They are very simple in their operation, doing all the work of laying the roof except fitting and driving the nails.

Steel or tin roofs should be painted upon the under side before being laid; then if kept painted upon the outside, they usually prove satisfactory.

If a metal roof is nailed directly upon the boards of the

roof, it will buckle, and in time crack, on account of the expansion and contraction; therefore roofing tacks, (Fig. 129, *b*), strips of tin or steel, are hooked over a standing seam, as at *b*, or a flat seam, as indicated by the dotted lines at *c*, to allow the roof to expand and contract, as the temperature changes.

The boarding of a roof which is to be covered with metal, should be perfectly smooth; upon the best work the roof is covered with matched boards. Upon all roofs which are to receive metal, the boards should be thoroughly seasoned, and carefully nailed down, to prevent any future warping and twisting. All nailheads should be set below the surface of the wood, to prevent the frost from backing them out. If there are knotholes, they should be covered with tin, and there should be no places where a corner of the boarding is likely to bear against the under side of the metal. Under the roofing there should be laid one or more thicknesses of paper, which add much to the life of the roof. Do not use tarred paper, as the acids in it will destroy the metal. Some builders object to the use of paper under a metal roof, claiming that it holds moisture, but it is certainly the best practice to use it, because it furnishes a cushion which protects the roofing from the roughness of the roofing boards; this is more important than any possible condensation.

If the carpenter is responsible, he should see that the work is done properly by the tinsmith, and that the right grades of all materials are used; only high-grade metal is suitable for roofing.

(B.) *Tin roofs* are often laid with a flat seam, commonly known as a lock joint, which should be made as shown in

Fig. 129, at *c*, and thoroughly fastened, not nailed through the tin into the roof, but through the cleats. These should be at the top of the sheet, which is usually 20'' × 28'', and should be placed between 12'' and 14'' apart. The seam should be well pounded down to make the joint as tight as possible.

In soldering, rosin should be used as a flux, but no acid, as it is apt to destroy the tin. No rosin should be left upon the tin, as it will prevent the paint from holding well.

Where a tin roof comes against a place which is shingled or sided, the tin should be turned up, and the shingles or clapboards of the lower course laid over it.

After the tin roof is laid, a good plan is to leave it for a few days, as it will then take the paint better, and if it is exposed to a shower, no harm will be done; this does not mean that an exposure to a long rainy spell is recommended.

The workmen must be careful to leave no loose nails upon the roof while at work, for if stepped upon they may punch a hole through the roof.

84. Slate roof. — A *slate roof* always should be laid by a thoroughly competent and reliable man, as any skimping of the work may not be discovered until the roof has served a part of its usefulness.

It is not good practice to lay a slate roof with a rise less than 5'' to 1'. The slate should be carefully selected for its color, and a brand used that is known to be tough and non-absorbent. The ordinary wire nail should not be used to fasten the slates, as it will rust off before the roof needs repairing otherwise. A tinned or galvanized nail will give good satisfaction, but upon the best work copper nails

should be used, and in all cases they should be driven where there is no danger of a joint coming over them.

In flashing a slate roof, the most durable material is generally the cheapest in the end; therefore copper is the best, though it is used only upon the most expensive work. Tin is used ordinarily and, if well painted before laying, and kept in good condition, it will be satisfactory, though the necessity of climbing over the roof to paint it is often the cause of breaking slates. Sheet lead often is used upon buildings of medium cost.

85. Gravel roofs. — *Gravel roofs* are used upon flat-roofed buildings. First it is necessary that there should be a smooth, tight roof upon which this is to be laid. There should be four thicknesses of roofing felt, laid with a lap of two thirds of the width, starting with one third of the first course of the second layer of felt at the eaves. All the layers after the first should be well mopped with pitch. The first should be laid dry, because, if laid in pitch, it will be cemented to the roof, and the shrinking of the roofing boards will be apt to break the paper.

The last layer should be nailed with 3d common nails, driven through tin disks about 30'' apart. A thick coat of moderately hot pitch is then laid on, over which is spread clean, well screened gravel, which, if laid in cold weather, should be warmed thoroughly.

In flashing a gravel roof the felt is turned up from 4'' to 6'', and held to a brick wall by nails driven through wooden laths, or to wood with nails driven through disks of tin; the whole is carefully bedded in thick pitch, and thoroughly doped. Care should be used that pitch is not daubed where it is not needed.

There are many different kinds of patent roofings upon the market, many of which are perfectly satisfactory, but a carpenter cannot afford to risk his reputation by putting on anything which he does not know to be all right, and which has not stood a reasonable test of time.

SUGGESTIVE EXERCISES

81. What is meant by the term "to the weather"? How much of a shingle is usually laid to the weather? Why is a shingle not laid 6" to the weather? What should be in place before the shingles are laid? In what respect does the lowest course differ from those above? What is the usual method of laying the lowest course? What is the least a joint should be broken? What sized nails and how many should be driven to each shingle? Why not more? Describe the method of treatment and the laying of dry shingles. Describe and compare two methods of laying shingles. Is it always necessary to build a scaffold in order to reshingle a roof? Describe and compare four different methods of hip shingling. Describe the common method of valley shingling. Describe a closed valley, and compare it with an open valley. How are tin shingles used in repairing leaks? How should a large leak be repaired? Describe the special tool used in removing shingles from a roof.

82. What is meant by "flashing"? Describe and compare three methods of flashing a shingle roof. Why is it the best method to use counter flashings around chimneys? How should the upper edge of the flashing be fastened to a skylight frame? How should the counter flashings be fastened to a brick chimney? How is it usually done? How should the flashing be put on in places where snow might collect?

83. Describe the standing-seam roof. How should the under side of the metal be treated before being laid? How should a tin roof be fastened to the roofing boards? How should roofing boards be laid? What should be their quality? How should nailheads be treated? How should knotholes be treated? Why is it advisable to paper a roof before putting on the roofing? What kind of paper should be avoided?

Describe a flat-seam roof. How should the roofing material be selected? How should a flat-seam roof be fastened? What should be used as a flux in soldering a tin roof? Is it the best plan to paint a tin roof as soon as it is laid?

84. What is the least rise which a slate roof should have? What kind of nails should be avoided? What is the best kind to use? What kind of nail is generally used? What is the best material for flashing a slate roof? What is ordinarily used?

85. When are gravel roofs laid? Describe the method of laying a gravel roof. How is a gravel roof flashed? What should be the attitude of the carpenter regarding patent roofings?

CHAPTER VIII

PLASTERING

86. **Laths.** — (A.) *Laths* are made of poplar, pine, spruce, oak, or almost any wood which may be desired, though the harder woods are less desirable, for if not thoroughly seasoned before laying, they may twist and either break the clinch or crack the mortar. Laths are usually made at the sawmills of the waste and edgings, and are of two widths, 1" and 1½". The former gives a better clinch to the mortar, while the latter makes the spaces between the studs stiffer; thus the conditions are about even as far as holding the mortar is concerned, but the wider laths may be laid faster, and require fewer nails.

(B.) *To minimize the danger of cracks* in an inside corner, it should be tied together by breaking the joints of the laths by some method similar to that indicated in Fig. 130, pieces of 2" × 4" (e) being nailed on after the laths are in place. On account of the length of time this takes, it is done only upon the best class of work. Ordinarily, the laths are

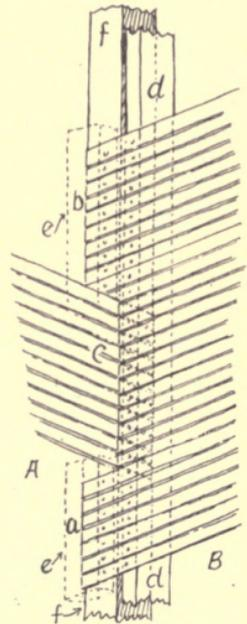

FIG. 130. — LATHING AN INSIDE CORNER.

laid the entire height of one wall, and nailed upon the stud, *f*, as shown by the dotted lines at *c*, and the furring piece, *d*,

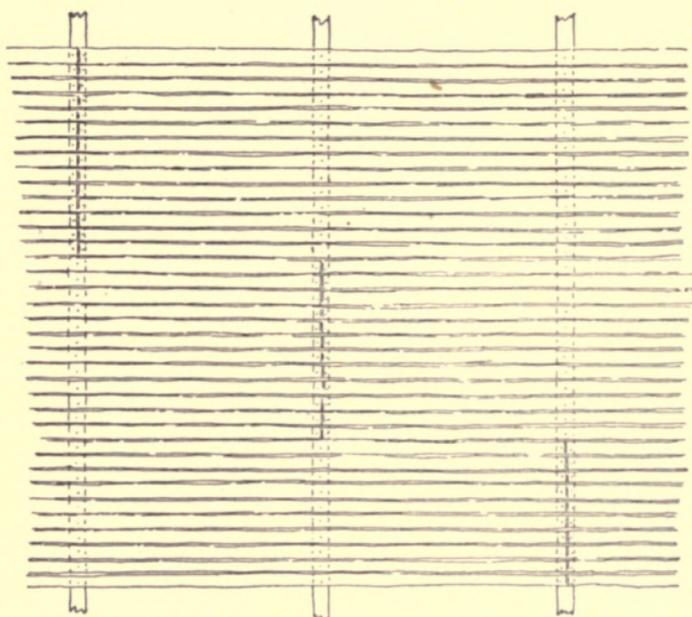

FIG. 131. — LATHING A STRAIGHT WALL.

nailed upon them to furnish a nailing for the laths of the other wall. Joints should not be made in the laths upon the stud above either side of a door frame, as the swinging and slamming of the

door will in time break the plastering at these joints. Laths should not be laid more than $\frac{5}{16}$ " apart, with one *3d* fine nail to each bearing.

The joints of the laths of a plain wall should be broken every 12 or 15 laths, as in Fig. 131. When the laths are laid directly upon a wide timber, their edges should be cut under, as shown in Fig. 132, to allow the mortar to clinch.

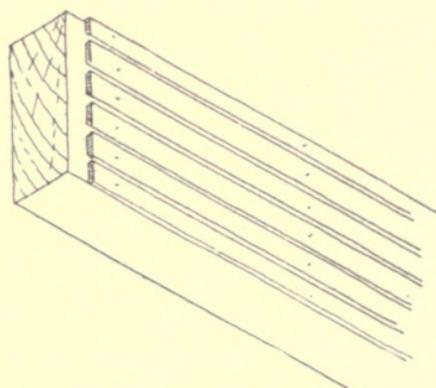

FIG. 132. — LATHING ON A WIDE TIMBER.

(C.) *An outside brick wall less than 16'' in thickness should have furring strips laid upon it, upon which laths should be laid. This allows an air space, which insures against moisture destroying the surface of the plaster, or causing the paper to peel off. (See D, Topic 14.)*

Studs for lathing should be 12'', 16'', or 24'' between centers, as the common length of laths is 48''. (See Topic 24.) Upon most work 16'' is the usual distance, but 12'' is sometimes used upon heavy buildings; 24'' is often the distance between centers of rafters, as sufficient strength is thereby secured, and unnecessary weight and expense is avoided; 16'' and 20'' spacing is common.

(D.) There are *several forms of patent laths*, some of wood made in the form of matched boards, which add much to the strength and warmth of the building. Others are of metal, and are used chiefly upon fireproof work, and for fitting around circular walls and awkward places.

In localities where considerable building is in progress, there are men who do nothing but lathing, and who are exceedingly expert at it. As these men usually are paid by the thousand it is the carpenter's place to prepare the nailings.

87. Corner finish.—Some form of corner finish is a necessity upon outside corners of a plastered wall, and *galvanized metal corners* should be nailed upon the laths. Of these there are several kinds, one of which is shown in Fig. 133. There is little choice among them. They

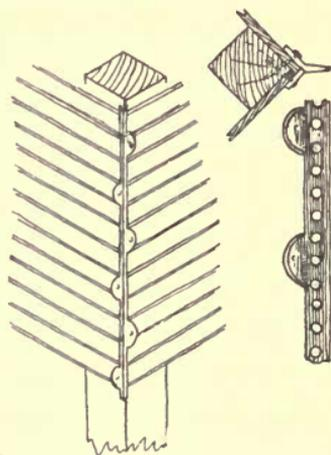

FIG. 133. — METAL CORNERS.

have supplanted all other methods of corner finish upon the best class of work.

Strips or casings should not be used upon corners, as they always make a bungling job, while the metal corners are perfectly firm and rigid. Another, and until recent years the common way, is to finish the corner by a *corner bead*, as shown in Fig. 134. This method makes more work for the plasterer, as the plastering has to be stopped against it, forming a querk, as at *a*, but it is still used to some extent, since if well done it makes a good-looking corner.

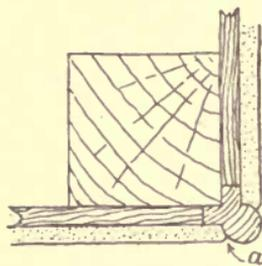

FIG. 134. — PLASTER BEAD.

88. Grounds. — *Grounds* should be nailed upon the studs around all openings before the house is lathed, at a distance sufficient to allow the casings to cover them, as shown at *a*, Fig. 135. They are also nailed to the bottoms of the partitions, at the proper height to receive the top of the baseboard, as at *b*, and a short strip for furring behind the base, as at *c*. They are for the purpose of giving the plasterer a ground upon which he may run his straightedge, to insure a straight wall, against which the finish may be fitted.

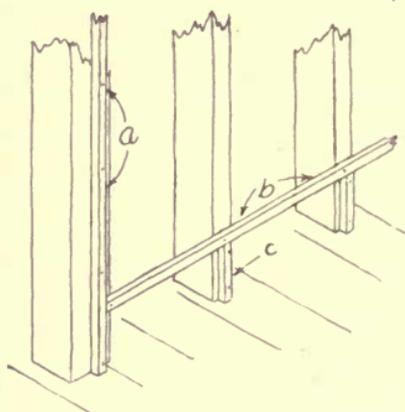

FIG. 135. — GROUNDS FOR PLASTERING.

The sizes of grounds vary in different localities; in some places they are $\frac{3}{4}'' \times \frac{7}{8}''$, laid so that the laths and plaster will be $\frac{3}{4}''$ thick. They are sometimes made of $\frac{7}{8}''$

square material, which makes the plaster $\frac{1}{8}$ " thicker. If the grounds are to receive the nails of the finish, they are sometimes 2" wide.

89. Plastering. — (A.) *In making mortar for plastering,* it is always wise to purchase some well-known make of lime, as it varies in quality and strength; but it is usually safe to allow 3 bushels of sand to one of lime and $\frac{2}{3}$ of a pound of hair.

Sand for plastering should be coarse, sharp, and clean; that taken from a river bed may be clean, but usually it is not sharp, though it is often used for mortar where none other is obtainable.

To test sand for clay or loam, put it in a glass of water. After being stirred, the sand will settle to the bottom, and the loam and clay, if present, will settle upon it. Another way is to squeeze a little damp sand in the hand; if it is free from clay or loam, it will fall apart as soon as the hand is opened.

If in doubt as to whether or not the sand is sharp enough, examine it with a microscope: if the corners of the grains are rounded, and the surface smooth and glassy, the sand should not be used.

Hair should not be put in the mortar until the lime has thoroughly slaked, as the heat will destroy it.

Either cow's or goat's hair is the kind generally used, the latter being preferred, as it is longer, finer, and mixes better. Manila and wood fiber are used to some extent as a substitute for hair, it being claimed that they are not affected by heat from imperfectly slaked lime.

It is a good plan to allow the mortar to stand a few days before it is used, as the quality of it is much improved, and

there will be no small lumps left unslaked, which often happens in mortar which has been made too hurriedly.

(B.) The plastering upon the best buildings is usually three-coat work.

The first, or *scratch coat*, consists of a layer of mortar $\frac{1}{4}$ " in thickness, spread evenly over the laths, and well pressed between them to form a clinch. The durability of the work depends to a great extent upon the strength of this clinch, so care should be used to make it effective. After the scratch coat has hardened from two to four days, it is scratched so that it will form a good key for the next coat, though some plasterers sweep the wall with a coarse broom while this coat is moist.

The scratch coat should be nearly dry, so that it will be stiff enough for the second or *brown coat* to key well into the scratches, and at the same time not so dry that the brown coat will not unite to it. If it is too dry, it should be dampened. After the brown coat is hard, but not thoroughly dry, it is ready for the *skim, or putty coat*, which is made of a thin coat of lime and plaster of Paris, and worked down very carefully to a smooth, hard finish. If the skim coat is not well put on, or if the plastering underneath is improperly dried, small cracks probably will appear upon the wall.

There are several methods of doing the different parts of the work, but the above is the method generally followed.

Upon work where economy is necessary, quite satisfactory results are obtained by two-coat work, in which the first coat is left in nearly the shape of the second coat, as above described; after drying sufficiently, the finishing

coat is laid directly upon it, being a little thicker than the skim coat of three-coat work. This method is not recommended where the best results are desired, as the skim coat is apt to crack or peel off.

Generally it is the carpenter's place to close in for the plasterer, by which is meant the closing of all openings to keep out cold and drafts which would cause freezing or uneven drying. Many builders plan to have the window sashes in place before the plasterers begin their work, especially in the winter time, but in general it is the custom to make rough frames and to cover them with a cheap cotton cloth, which allows the light to pass through, but keeps out the drafts. If the air is very dry and warm, this is sometimes as necessary as it is to keep out the cold in winter, for if plaster dries too rapidly, it will crack badly; the surface should not dry faster than the back. When it is necessary to have fire to assist in drying out plaster, or to keep it from freezing, it is generally the plasterer's place to maintain it. In many parts of the country, it is rarely necessary to use these precautions, but in parts where there is danger of the plaster freezing, or of drying too rapidly or unevenly, all reasonable precautions should be taken.

There are a number of different makes of prepared plaster upon the market, which are fast gaining the favor of architects, as they are lighter than lime mortar, more easily applied, dry more quickly, are less apt to freeze, and are not so liable to crack after the wall is finished, and when the building seasons. There is little doubt that ultimately they will be used almost universally, as they are now specified upon the best work.

90. Back plastering. — *Back plastering* consists of laying a coat of plaster upon laths which are nailed upon the inside of the outside boarding between the studs, and is frequently used in the outside walls of the better houses in the cold climates, as it adds much to the warmth of the building. Only one coat of low grade mortar with a little hair is necessary, but it must be well clinched and spread thickly, though it may be put on very roughly, as it is out of sight. It is not so expensive as it may seem at first, and the additional comfort with the resulting economy of fuel will repay in a short time the extra cost.

91. Deadening. — By *deadening* is meant the constructing of floors and partitions so that the passage

of sound is reduced to a minimum. Figure 136 shows a method in which a weak mortar, or mineral wool,

is the means of deadening a

floor, the mortar being of the proportions of one of lime to seven or eight of sand, the hair being omitted altogether. If used in a partition, laths should be laid diagonally, as shown in Fig. 137, and plastered as described in the previous topic.

There are several varieties of sheathing paper or quilt upon the market which may be used, by spreading one or more layers upon the under floor, and laying the wear-

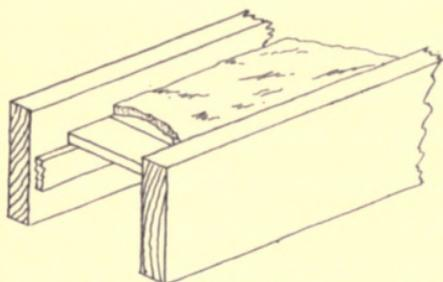

FIG. 136. — DEADENING A FLOOR; METHOD 1.

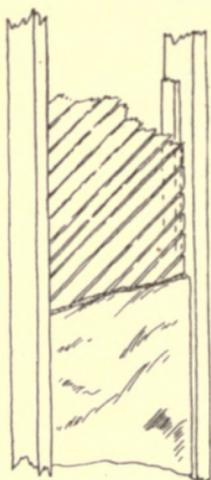

FIG. 137. — DEADENING A PARTITION.

ing floor upon it. While this is of some help, it does not give satisfactory results.

Another method of treating a floor is shown in Fig. 138, which is more expensive, but also more efficient than that described in Fig. 136, as the mineral wool is only about a sixth as heavy as the lime mortar. In this latter method, the 2" piece supporting the wearing floor should not be nailed

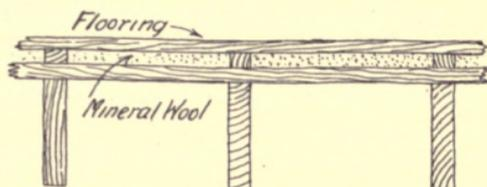

FIG. 138. — DEADENING A FLOOR ;
METHOD 2.

to the under floor more than necessary, as a connection will thereby be formed which will impair the efficiency of the deadening. Several thicknesses of sheathing paper between the deadening and the under floor will aid a great deal.

SUGGESTIVE EXERCISES

86. Of what kinds of wood should laths be made? Why? Compare the efficiency of the two widths of laths. The economy. Illustrate the methods of joining laths at the inside corners. How should laths be laid over door studs? How should laths be treated which are laid upon a wide timber? How should the inside of a 12" brick outside wall be treated if it is to be plastered? Why?

87. How should outside plastered corners be treated? Describe and compare two other methods of finishing corners.

88. What are grounds used for? What are the common sizes of grounds?

89. What are the proportions of sand, lime, and hair used in making mortar? When should the hair be put in? Which is the kind of hair generally preferred? What kind of sand should be used in mortar? How can sand be tested for clay or loam? Is creek sand suitable for mortar? Should mortar be used as soon as it is made? Why? How

should plastering be put on to insure that it will hold? Describe the different coats of three-coat work. Of two-coat work. What governs the thickness of the plastering? What is the carpenter's work in making the building ready for the plasterer? Compare lime plaster, and ready mixed plaster.

90. Describe back plastering. What is the value of it to a house?

91. What is meant by deadening? Describe a method of deadening a floor. A partition. Describe the most efficient method of deadening a floor.

GLOSSARY

OF TERMS USED IN ARCHITECTURE AND CARPENTRY

- ABACUS.** The upper plate of a capital, upon which the architrave rests.
- ABUTMENT.** A foundation ; a support.
- ACANTHUS.** A leaf, the conventionalized form of which is used upon the Corinthian and composite orders of architecture.
- ALBURNAM.** Sap wood.
- ANCHOR.** Irons of special form used to fasten together timbers or masonry, or both.
- ANNULET.** A small, flat fillet encircling a column.
- ARCADE.** A series of arches ; a long arched building.
- ARCH.** A form of construction which is supported by the pressure of each member against those adjoining.
- ARCHITRAVE.** The part of an entablature which rests upon the column. The term is also applied to door and window casings.
- ARRIS.** The edge formed by two concave surfaces meeting each other, as the edges which separate the flutes of a Doric column.
- ARRIS FILLET.** A triangular piece of wood so arranged as to conduct the water away from the joint between the roof and a chimney or other vertical projection ; a cricket ; a saddle.
- ASHLAR.** A wall of cut stone.
- ASTRAGAL.** A small round molding surrounding a column. It is also applied to a molding used in laying off panels upon flat surfaces and for similar purposes.
- BACK FLAPS.** Oblong-shaped hinges, shorter than strap hinges but generally applied in the same manner.
- BACKING.** The bevel upon the top edge of a hip rafter which allows the roofing boards to fit the top of the rafter without leaving a triangular hole between it and the back of the roof covering.

- BALCONY.** A platform projecting from the side of a house, usually inclosed with a balustrade, and more or less embellished.
- BALDACHIN.** A canopy placed over doors, thrones, etc., and supported either from the wall or by columns.
- BALLOON FRAME.** The lightest form of construction, generally used only upon the cheapest grade of work.
- BALUSTER.** A small column used to support a rail.
- BALUSTRADE.** A row of balusters with the rails, generally used for porches, etc.
- BAND.** A low flat molding.
- BARTIZAN.** A small overhanging turret which projects from the angles of towers or other parts of a building.
- BASE.** The bottom of a column; the finish of a room at the junction of the walls and floor.
- BAST.** The inner bark of a tree.
- BASTON.** A round molding used in the base of a column; the torus.
- BATTEN.** A narrow strip of board.
- BATTER BOARD.** A temporary framework used to assist in locating the corners when laying out a foundation. *See* Topic 3.
- BATTLEMENT.** A parapet used upon ancient fortresses, notched to give protection to those behind it.
- BAY WINDOW.** A window projecting beyond the wall, sometimes called a bow window.
- BEAD.** A small round molding.
- BEAM.** A horizontal timber used to resist weight or to hold other timbers in their places.
- BEDDING.** A filling of mortar, putty, or other substance in order to secure a firm bearing.
- BEVEL BOARD.** Used in framing a roof to lay out bevels.
- BLOCKINGS.** Pieces of wood fitted and glued to the inside angle of a joint in order to strengthen it; glue blocks.
- BOARDING IN.** The process of nailing boards upon the outside studing of a house.
- BONDING.** The method of laying brick so that each course will strengthen the one below it and assist in binding the wall together.

- BRACES.** Pieces fitted and firmly fastened at an angle with two others in order to strengthen the angle thus treated.
- BRACKET.** A support for a shelf.
- BREAK JOINTS.** To arrange joints so that they will not come directly under or over the joints of adjoining pieces, as in shingling, siding, etc.
- BRICK NOGGIN.** A few courses of brick laid dry at the bottom of a studded wall to prevent the passage of flames or vermin.
- BRIDGE MEASURE.** The distance across an angle from a given point upon each side of it; the hypotenuse of a right-angled triangle.
- BRIDGING.** Pieces fitted in pairs from the bottom of one floor joist to the top of the one next to it, and crossed to give additional strength to the flooring.
- BUILDING PAPER.** Cheap, thick paper, used for additional warmth in covering a building before the siding is put on.
- BUILT TIMBER.** A timber made of several small pieces and forming one of large dimensions.
- BUTTRESS.** A projecting support which adds to the strength of a wall.
- BUTTRESS, FLYING.** Used to strengthen a part of a building which is higher than the rest; a sort of curved brace.
- BUTTRESS, HANGING.** A buttress supported upon a corbel.
- BUTTRESS STEPS.** Sometimes applied to a flight of closed string steps.
- CAMBIUM.** The part of a tree between the bast and the sap wood, from which is developed the new wood each year.
- CANOPY.** An ornamental projection over doors and windows.
- CANTILEVER.** A timber, stone, or metal beam which projects to form a support, and extends back far enough over its own support to carry its load safely.
- CAPITAL.** The upper part of a column which supports the entablature, usually more or less ornamented.
- CARRIAGES, OR STRINGERS.** The supports of the steps and risers of a flight of stairs. The wall string is fastened to the wall, and the face string is upon the outside of the stairs.
- CASEMENT.** A glazed sash or frame which opens upon hinges.

- CASING.** The trimming around a door or window opening, either outside or inside.
- CASTELLATED.** Having turrets and battlements like a castle.
- CASTING.** The bending of a board widthways; warping.
- CATHERINE-WHEEL WINDOW.** A window divided into radiating sections.
- CAUL.** A piece of wood used between the clamps and veneer to clamp thin veneer to its place.
- CAVETTO.** A hollow molding, used generally in cornices.
- CEILING.** Narrow matched boards; sheathing; the surface which encloses the upper side of a room.
- CENTER HUNG SASH.** A sash hung on its centers so that it swings horizontally.
- CHAMFER.** A bevel upon the corner of a square piece of wood.
- CHANCEL.** The space between the altar and the rail inclosing it.
- CHAPTREL.** The capital of a pier or pilaster, which receives an arch.
- CHATTERS.** The splinters which are broken off if end wood is planed unskillfully.
- CHECKS.** Splits or cracks in a board, — generally called shakes.
- CHEEK, OR SIDE CUT.** The cut made upon the side of a rafter to allow it to fit against the piece with which it intersects.
- CHORD.** Applied to an arch. The span or the distance between its supports.
- CINQUEFOIL.** An ornamental foliage having five points or cusps.
- CLAMP.** A device used to strengthen, or to hold in place.
- CLAPBOARDS.** The outside covering of a house; siding.
- CLUSTERED COLUMN.** One composed really or apparently of a number of columns together.
- COLUMNS.** A support, generally cylindrical in section, for roofs, ceilings, etc., composed of base, shaft, and capital.
- COMBINATION FRAME.** A combination of the principal features of the full and balloon frames.
- COMPOSITE ORDER.** A combination of the Ionic and Corinthian orders.
- CONCRETE.** A combination of sand, broken stone, and cement used in foundations, building construction, and for walks.

- CONDUCTORS.** Pipes for the purpose of conducting water from a roof to the ground, or to a receptacle or drain; a downspout.
- CONSOLE.** A bracket, or projecting ornament on the keystone of an arch, often used to support small cornices.
- COPING.** The highest, or covering course of masonry. Often beveled to carry the water away; also called capping.
- CORBEL.** A bracket used to support arches, statuary, etc.
- CORE.** The basis of veneer work, usually of soft wood, thoroughly seasoned.
- CORINTHIAN ORDER.** The most delicate and elaborate of the orders. The order which governed much of the later Grecian architecture.
- CORNER BOARD.** The casing which finishes the corner of a frame house.
- CORNICE.** Any molded projection which finishes the top of the piece of work upon which it is used.
- BOX CORNICE.** The form of cornice which is finished under the eaves, or boxed in.
- OPEN CORNICE.** A form of cornice which allows the ends, or look-outs of the rafters to be seen.
- CORONA.** The principal projection of a cornice.
- COUNTER FLASHINGS.** Used to prevent water from entering the top edge of the vertical side of a roof flashing. Also they allow expansion and contraction without danger of breaking the flashing.
- COVE.** An arch or hollow molding where the ceilings connect with the walls.
- CRICKET.** A piece of wood fitted between a slanting roof and a vertical surface to carry the water away from the joint; a saddle. *See Arris Fillet.*
- CROCKET.** An ornament to represent foliage; much used upon Gothic buildings.
- CROWNING SIDE OR EDGE.** The side or edge which is rounding, or of convex shape. Generally applied to the edges of boards, or to any surface which is higher in the middle than at the sides.
- CROWN-POST.** The middle post of a trussed roof; a king-post.
- CUPOLA.** A domelike structure upon the top of a building; a term commonly applied to a small tower or turret.
- CURB PLATE.** The plate in a curb roof which receives the upper rafters.

CURB ROOF. A roof formed by two sets of rafters meeting at an angle and supported at the joint by a curb plate.

CURB STAIRS. Stairs with a closed string.

CYMA. A molding composed of a hollow and a round; an ogee.

DADO. The part of a pedestal of a column which is between the base and the cornice, under the base of the column itself; the panel work or other method of filling between the base board and the cap molding or chair rail.

DADO, RAKE. Dado extending along a flight of stairs, the rails parallel with the pitch of the stairs and the stiles, muntins, and panels running plumb.

DEADENING. Construction intended to prevent the passage of sound.

DECK. A flat place upon the roof of a building.

DENTILS. Formed by a series of blocks of different shapes, generally rectangular, and used in the cornices of the Ionic, Corinthian, and composite orders.

DORIC ORDER. Distinguished for its simplicity and strength.

DORMER WINDOW. A window placed upon a roof, the frame being vertical, and the plate parallel with the main plates of the house.

DOWEL. A round stick, commonly used in gluing up, as a substitute for a mortise joint, and in strengthening the joints in a wide board.

DOWN CUT. The vertical cut of rafters. Also called the plumb, or ridge cut.

DRIP. The projection of a window sill or water table to allow the water to drip clear of the side of the house below it.

DURAMEN. Heart wood.

EASEMENT. A section of the handrail for stairs which allows the hand to glide easily from one level to another, or around an angle; an ease-off.

ECHINUS. A molding of the shape of the ovolo or quarter round, which is decorated with an egg and dart design.

EIGHT-SQUARE. Of octagonal shape.

END FOR END. Reversing ends.

- ENGAGED COLUMNS.** Columns sunk partly into the wall to which they are attached.
- ENTABLATURE.** The part of either of the orders of architecture which is above the capital, including the architrave, frieze, and cornice.
- FAÇADE.** Front view, or elevation of an edifice.
- FACE SIDE, OR EDGE.** The side or edge from which all of the measurements, and all tests for accuracy are made.
- FAIR.** When a piece of wood or work is perfectly straight, true, and out of wind; not necessarily level, as the board may be set at any angle.
- FASCIA.** A flat member of a cornice or other finish, generally under the upper member of the cornice.
- FENCE.** A part of a molding tool which regulates the distance of the cut from the edge; a piece of wood, adjustable upon the steel square to enable the square to be used as a bevel.
- FESTOON.** An ornament, generally of fruits and flowers, hanging from the ends, the middle being allowed to drop to a natural position.
- FILLET.** A small square member of a molding.
- FILLING THE GRAIN.** A process of filling the pores of the wood so that there will be a perfectly smooth surface upon which to apply the finish.
- FINIAL.** An ornament which forms the finish for the tops of towers, and points of pitch roofs.
- FINISH.** A term applied to stain, varnish, etc.; the woodwork which completes the inside or the outside of a house.
- FLASHING.** . The process of making the roof, and other exposed places upon the outside of the house watertight.
- FLUE.** The opening in a chimney through which the smoke passes.
- FLUSH.** When two pieces are perfectly even.
- FLUTE.** An ornamental, concave groove used for the purpose of decoration.
- FOIL.** A leaflike ornamentation of windows, niches, etc.
- FOLIATION.** An enrichment by ornaments resembling leaves.
- FOOTING COURSES.** The bottom and heaviest courses of a piece of masonry.

- FRESCO.** A method of painting on plastered walls and ceilings.
- FRET.** An ornament consisting of intersecting lines.
- FRIEZE.** The part of an entablature between the architrave and cornice.
- FULL FRAME.** The old-fashioned, mortised and tenoned frame, in which every joint was mortised and tenoned. Rarely used at the present time.
- FURRINGS.** Narrow strips of board nailed upon walls and ceilings to form a straight surface upon which to lay the laths or other finish.
- GABLE.** The vertical triangular end of a building from the eaves to the apex of the roof.
- GABLE WINDOWS.** A window in a gable, or one pointed at the top like a gable.
- GAIN.** The shoulder upon the tenoned piece of a mortised and tenoned joint.
- GALLERY.** A partial story.
- GIRDER.** A principal beam.
- GIRT.** A small girder, used in roofs. Sometimes in practice the term is used interchangeably with girder. The horizontal member of the walls of a full or combination frame house which supports the floor joists, or is flush with the tops of the joists.
- GLUE BLOCKS.** *See* Blocking.
- GOTHIC.** The style of architecture with high gables, pointed arches, clustered columns, etc. Used extensively for churches.
- GRAVITY HINGES.** Those which open and close if once set in motion.
- GROINED ARCH.** The intersection of two arches.
- GROUNDS.** Strips of wood for the purpose of assisting the plasterer in making a straight wall, and in giving a place to which the finish of the room may be nailed.
- GUTTER OR EAVES TROUGHS.** Troughs which catch the water from the roof and carry it to the conductors.
- HEADER.** A short joist supporting tail beams, and framed between floor joists. The piece of stud or finish over an opening. A lintel. The piece against which the top ends of stair stringers rest.

- HEADROOM.** The height between the top of the tread at the riser line, and the ceiling directly above it.
- HELIX.** The shape of the elevation of a flight of circular stairs.
- HIP MOLDING.** A molding which covers the hip of a roof.
- HIP ROOF.** A roof which slopes toward the center from all sides, necessitating a hip rafter at each corner.
- HOOD MOLDING.** A molding projecting over the head of an opening.
- HOPPER CUT.** The cut necessary to allow the sides of a hopper to fit together.
- IMPOST.** A capital from which springs an arch. A chaptrel.
- INTERLACING ARCHES.** Arches so constructed that their curves intersect or interlace.
- IONIC ORDER.** Distinguished by the volute in its capital. Column more slender than the Doric or Tuscan, but less slender and less elaborate than the Composite or Corinthian.
- JAMB.** The side piece or post of an opening. Sometimes applied to the door frame.
- JOGGLES.** Projection of timbers or stones fitting each other.
- JOINT, STANDING.** A joint which allows light to be seen under a try-square upon the face corner.
- UNDER.** A joint which allows light to be seen under a try-square upon the back corner; the reverse of a standing joint.
- JOINTS, BUTT.** Squared ends or ends and edges adjoining each other.
- DOVETAIL.** Made by cutting pins the shape of dovetails in section, which fit between other dovetails upon another piece.
- DRAWBORED.** A mortise and tenoned joint with holes so bored that when a pin is driven through, the joint will be made tighter.
- FISHED.** An end butt joint strengthened by pieces nailed upon the sides.
- GLUE.** A square edged joint held together with glue.
- HALVED.** Made by cutting half of the wood away from each piece, so as to bring the sides flush.
- HOUSED.** Grooved to receive the piece which is to form the other part of the joint.

JOINTS. LAP. Two pieces lapping over each other.

MORTISED. Made by cutting a hole, or mortise, in one piece, and a tenon, or piece to fit the hole, upon the other.

RUB. A glue joint made by fitting carefully the edges together, spreading glue between them, and rubbing the pieces back and forth until the pieces are well rubbed together.

SCARFED. A timber spliced by means of cutting various shapes of shoulders, or joggles, to fit each other.

JOISTS. Timbers supporting the floor boards.

KERF. The cut made by a saw.

KILN. An apparatus for rapid artificial drying.

KILN-DRYING. The process of drying in a kiln.

KING-POST. A post rising from a tie beam to the apex of the rafter.

LANCET WINDOW. A narrow, pointed window.

LATHS. Narrow strips to support plastering.

LATTICE. Crossed wood or iron slats or bars.

LEDGER BOARD. The support of the second floor joists of a balloon-framed house, or for similar uses; a ribband.

LEVEL. A term describing the position of a line or plane when parallel to the surface of still water.

LIFT. The section of a roof raised to form a substitute for a dormer window. An elevator or dumb waiter.

LINTEL. The piece of construction or finish, stone, wood, or metal, which is over an opening. A header.

LOCK JOINT. A form of halved joint in wood. Upon metal roofs, the edges are turned over and lapped into each other, flattened down and soldered.

LOOKOUT. The end of a rafter, or the construction which projects beyond the sides of a house to support the eaves.

MANTEL. The shelf over a fireplace.

MATCHING, OR TONGUEING AND GROOVING. The method commonly used in making the best grades of flooring.

MEETING RAIL. The bottom rail of the upper sash, and the top rail of the lower sash of a two-sash window.

- MINARET.** A slender lofty turret.
- MITER.** The joint formed by pieces meeting at an angle.
- MODILLION.** An enriched block used under a cornice of the Corinthian order, and to some extent in the other orders.
- MOLDING. BASE.** The molding upon the top of a base board.
- BED.** Used to cover the joint between the plancer and the frieze; also as a base molding upon heavy work, and sometimes as a member of a cornice.
- LIP.** Has a lip which overlaps the piece against which the back of the molding rests.
- RAKE.** The cornice upon the gable edge of a pitch roof, the members of which are made to fit those of the molding of the horizontal eaves.
- ROOM.** Shaped so as to form a support for picture hooks. Placed some distance from the ceiling upon the wall, to form the lower edge of the frieze.
- MORTISE.** The hole which is to receive a tenon, or any hole cut into or through a piece by means of a chisel; generally of rectangular shape.
- MULLION.** The construction between the openings of a window frame made to accommodate two or more windows.
- MUNTIN.** The vertical member between two panels of the same piece of panelwork.
- MUTULE.** A projecting block under the corona of a Doric cornice; used in a manner similar to the modillion of a Corinthian cornice.
- NAVE.** The main part of a church.
- NECKING.** A small molding used to surround a column, forming a neck below the capital.
- NEWEL.** The principal post at the foot of a staircase; also the central support of a winding flight of stairs.
- NICHE.** A cavity or recess; usually the receptacle for a bust or a piece of statuary.
- NOSING.** The part of a stair tread which projects over the riser, or any similar projection; a term applied to the rounded edge of a board.

OGEE. A molding consisting of two members, a hollow and a round; a compound curve. *See* Cyma.

ORIEL WINDOW. A large bay window in a hall or chapel.

OVOLO. A round molding; a quarter round.

PANEL. The sunken portion of a door; a depression in a wall lower than the surrounding portions.

PAVILION. A temporary movable building or tent.

PEDESTAL. The support of a column; generally consisting of a base, panel, and cornice.

PEDIMENT. The triangular, ornamental facing of a portico, or similar decoration over doors and other openings; also applied to circular or other spaces.

PENDANT. A hanging ornament; a drop.

PIAZZA. A veranda.

PIERS. Masonry supports, set independently of the main foundation.

PILASTER. A square column, usually set within a wall.

PILES. Long posts driven into the soil in swampy locations or wherever it is difficult to secure a firm foundation, upon which the footing course of masonry, or timbers, are laid.

PINNACLE. A slender turret, or the part of a building elevated above the main building.

PITCH. The inclination, or slope of roofs or stairs.

PITCH BOARD. A board sawed to the exact shape of a stair tread and riser, and used to lay out the stringers.

PLANCER. The under side of a cornice; a soffit.

PLATE. The top piece of the walls of a frame building, upon which the roof rests.

PLATE CUT. The cut is a rafter which rests upon the plate; sometimes called the seat cut.

PLINTH. A projecting, vertically faced member, forming the lowest division of the base of a column.

PLUMB CUT, RIDGE CUT, OR DOWN CUT. The cut made at the top end of a rafter to allow it to fit against the ridge or the rafter of the other side.

PORCH. An ornamental entrance way.

- PORTICO.** A covered space inclosed by columns at the entrance of a building; a porch.
- PULLEY STILE.** The member of a window frame which contains the pulleys, and between which the edges of the sash slide.
- PURLIN.** A timber supporting rafters in the middle.
- PUTLOG.** A piece of timber supporting the planks of a staging, one end of which rests in a hole in the wall left for it, and the other upon the ledger board.
- QUARTER ROUND.** *See* Ovolo.
- QUEEN-POST.** A post framed between the tie-beam and the rafter.
- QUIRK.** A small acute member of a molding.
- RABBET, OR REBATE.** A corner, cut out of a piece of wood.
- RAFTERS. COMMON.** Those which run square with the plate and extend to the ridge.
- CRIPPLE.** Those which cut between a valley and hip rafters.
- HIP.** Those extending from the outside angle of the plates toward the apex of the roof.
- JACKS.** Those square with the plate and intersecting with the hip rafter.
- VALLEY.** Those extending from an inside angle of the plates toward the ridge or center line of the house.
- RAIL.** The horizontal members of a balustrade, or panelwork.
- RAIL BOLT.** A specially shaped bolt which is used to strengthen the joint of a rail, or to fasten it to the stair post.
- RAKE.** Work extending in an oblique direction, as rake dado, or molding.
- RAMPED RAIL.** A veranda rail curved upward near its end to which is joined a straight piece of the same molding.
- RECESS.** Part of a room formed by the receding of the wall; an alcove; a niche.
- RELISH.** The short tenon between the edge of the tenon and the edge of the rail; used upon the top and bottom rails of panelwork.
- RETURN.** The continuation of a molding or finish of any kind in a different direction.

- REVEAL.** The brick or stonework visible between a window frame and the face of the wall.
- RIBBAND.** *See* Ledger Board.
- RIDGE CUT.** *See* Plumb Cut.
- RISER.** The vertical board between two treads of a flight of stairs.
- RISER LINE.** The line formed by the face of the riser.
- ROWLOCK ARCH.** An arch preventing the weight of the wall above from bearing entirely upon the lintel, often called a relieving arch.
- RUBBLE.** Masonry of uncut stone.
- SADDLE.** A piece of wood fitted to carry water away from a slanting roof and a vertical surface. *See* Cricket; Arris Fillet.
- SADDLE BOARD.** The finish of the ridge of a pitch roof house.
- SAWING. PLAIN.** Lumber sawed regardless of the grain, the log simply squared and sawed to the desired thicknesses; sometimes called slash or bastard sawed.
- QUARTERED.** Sawed as nearly parallel to the medullary rays as possible; much used in woods with a coarse medullary ray, and for lumber which has to stand hard usage or resist trying conditions. Also called rift sawed, and comb or vertical grain.
- SCAFFOLD. STAGING.** A temporary structure to allow the workmen to reach a high place.
- SCALE.** A short measurement used as a proportionate part of a larger dimension.
- SCANTLING.** Pieces of light framing material.
- SCARFING.** A joint between two pieces of wood which allows them to be spliced lengthways.
- SCOTIA.** A hollow molding used as part of a cornice, and frequently under the nosing of a stair tread. A cove molding.
- SCRIBING.** Fitting a piece to an irregular surface.
- SCROLL.** A spiral ornament.
- SEAT CUT OR PLATE CUT.** The cut at the bottom end of a rafter to allow it to fit upon the plate.
- SEAT OF RAFTER.** The horizontal cut upon the bottom end of a rafter which rests upon the top of the plate.

- SETTINGS.** Masonry for installing a furnace, fireplace, or other work which is supported by masonry.
- SHAKES.** Imperfections in timber caused during the growth of the tree by high winds or imperfect conditions of growth.
- SHEATHING.** Ceiling or narrow matched boards; the term is often applied to covering boards or sheeting.
- SHEATHING PAPER.** The paper used under the clapboards to assist in making the house warmer; building paper.
- SHEETING.** SHEATHING. Roofing boards; generally applied to narrow boards laid with a space between them.
- SIDING.** The outside finish between the casings; clapboards.
- SILLS.** The timbers of a house resting upon the foundations.
- SIZING.** Working material to the desired size; a coating of glue, shellac, or other substance applied to a surface to prepare it for painting or other method of finish.
- SKEWBACK.** The stone upon which an arch rests, shaped to resist the thrust.
- SLIP STONE.** A whetstone of a form to fit irregularly shaped tools.
- SOFFIT.** The under side of stairways, arches, cornices, etc.
- SPALLS.** The splinters caused by corners rubbing together; stone cuttings or chips.
- SPAN.** The distance between the bearings of a timber or arch.
- SPECIFICATIONS.** The written or printed directions regarding the details of a building or other construction.
- SPIRE.** The tapering portion of a steeple.
- SPLASH BOARD.** A board arranged to prevent the splashing of water from damaging a building.
- SPLAYED JAMB.** A jamb, the face of which is set at an angle of other than 90° with the face of the wall.
- SPLICING.** Joining wood lengthways.
- SQUARE.** A tool used by mechanics to obtain accuracy; a term applied to a surface including 100 square feet.
- STAFF BEAD.** The molding between a window or door frame and the masonry of a brick or stone building.
- STAIR-POSTS.** GALLERY. Situated at the end of the landing or gallery which supports the stairs, and connected with the landing post by the gallery rail.

- LANDING.** The post at the head of an ordinary flight of stairs.
- NEWEL.** The main post at the bottom of the flight. *See* Newel.
- PLATFORM.** The post supporting the stair stringers when the angle is turned by a platform.
- STARTING.** The post used to start the stairs from the second floor.
- WINDER.** The post to receive the risers of the winding treads.
- STAIRS. BOX.** Those built between walls.
- DOG-LEG.** The face stringer of one flight directly under that of the one above.
- PLATFORM.** A tread which turns an angle in the stairs with but one riser.
- STRAIGHT.** A flight with no turn.
- WINDING.** A flight with an angle which is turned by two or more steps.
- STALL.** A small place of business, where merchandise is exposed for sale; a compartment in a stable for the accommodation of a horse.
- STANDING FINISH.** Term applied to all of the finish of the openings, the base, and other finish necessary for the inside of a house.
- STILE.** The vertical pieces at the ends of a piece of panelwork.
- STOOP.** A small porch, usually but little wider than the width of the steps, and protected by a hood roof.
- STRAPPING.** Narrow boards so placed as to furnish a straight surface for lathing and plastering.
- STRIKER.** The piece of metal upon the jamb against which the latch of a door strikes when the door is closed.
- STUCCO.** A plaster used for interior decoration and fine work.
- STUDDING.** The framework of a partition or the wall of a house.
- SURBASE.** A cornice or series of moldings on the top of the base of a pedestal; the finish of the top of a piece of dado or wainscoting; sometimes called the chair rail.
- TAIL BEAM.** The joists extending from a header to the wall.
- THIMBLE.*** A terra cotta or metallic tube for the purpose of allowing a stovepipe to pass through a wooden construction without danger of fire.
- THOUSAND SHINGLES.** The equivalent to 1000 shingles 4" wide.

- THRESHOLD.** The beveled piece over which a door swings. Sometimes called a carpet-strip.
- TIE-BEAM.** A beam so situated that it will tie the principal rafters together, and prevent them from thrusting the plate out of line.
- TIN SHINGLE.** A small piece of tin used in flashing and repairing a shingle roof.
- TORUS.** A large semicircular molding.
- TO THE WEATHER.** The projection of shingles or siding beyond the course above.
- TOWER.** A lofty building, standing separately, or a part of another building.
- TRACERY.** The ornamental arrangement of the members of the window frames and sash, into arches, etc.; much used in Gothic architecture.
- TRANSEPT.** The part of a church at right angles to the nave.
- TRANSOM.** A horizontal crossbar over a door or window.
- TRANSOM SASH.** The sash supported by a transom bar.
- TREAD.** The horizontal part of a step.
- TRELLIS.** A screen. Often used as a support for plants or running vines.
- TRIM.** A term sometimes applied to the finish around an opening.
- TRIMMING.** Putting the hardware trimmings upon doors or other pieces of wood work; painting the trimmings of a house.
- TRUSS.** A specially constructed girder or other timber; a form of construction used to support a roof, floor, or where it is undesirable that a post should be used.
- TURRET.** A tower or spire attached to a building and rising above it.
- TUSCAN ORDER.** The most ancient and simple of the orders of architecture.
- VENTILATED WALL.** A brick wall containing hollow spaces, which add much to the warmth and dryness of the house.
- VESTIBULE.** An entrance to a house; usually inclosed.
- VOLUTE.** A spiral scroll; used in the more ornamental orders of architecture.

WAINSCOTING. Panelwork finish upon a wall.

WARP. The convex or concave shape assumed by a board exposed to dampness upon one side, and drier air upon the other.

WASH. The slant upon a sill, capping, etc., to allow the water to run off easily.

WATER TABLE. The finish at the bottom of a house which carries the water away from the foundation.

WEATHER DRIED. The term applied to lumber which has been dried by the open air.

WELL-HOLE. The opening through the center of a flight of circling stairs; also present wherever stairs are built above each other, unless a dog-leg flight is built.

WIND (*i* as in *kind*). A term used to describe the surface of a board when twisted, or when it rests upon two diagonally opposite corners, if laid upon a perfectly flat surface.

WOODEN-BRICK. Pieces of seasoned wood, made the size of a brick and laid where it is necessary to provide a nailing.

WREATH. A piece of specially made stair rail which carries the hand easily around a curve and to a different level at the same time.

INDEX

- Air spaces, 18.
Anchor bolts, 17.
Anchoring, 16.
Arched openings, 17.
Arches, rowlock or relieving, 17;
 thrust of, 17.
Architect, 2, 6.
Ashlar, broken and coursed, 9.
Asphalt, damp proofing with, 11;
 paper, 11.
- Backing of hip rafter, 87;
 for polygonal roofs, 100.
Balloon frame, described, 26;
 relation to the half frame, 23;
 reputation, 27.
Bank, caving in of, 6.
Bars, twisted, 8.
Base, or watertable, 117.
Batten, laying out curves with a, 125.
Batter boards, use of, 4.
Beams, use of I, 8.
Bedded flashings, 135.
Bed rock, for foundation, 2.
Belly rod truss, 38.
Belt holes, 50.
Bevel board, 55, 73.
Beveled siding, 116;
 for circular tower, 122.
Bird's mouth joint, 75, 102.
Boarding in diagonal corners, 109;
 diagonal and horizontal boarding,
 108;
 for sheet metal, 138.
Board measure, 53.
Bonding, in brick work, 15-16;
 with metal, 16.
Bond stone, 9.
Brace measure, 54.
Braces, 29;
 dimensions of, 26.
- Brick, bats, 14;
 bedded in mortar, 14;
 corbels, 17, 47;
 face, 13, 14;
 fire, 14;
 flashing around, 135;
 headers, 15;
 joints, 14;
 laying in cold weather, 15;
 noggin, 27;
 painting brick walls, 19;
 partitions, 50;
 plastering brick walls, 19, 145;
 resistance to fire, 13;
 sorting, 15;
 stretchers, 15;
 testing, 14;
 thickness of brick walls, 17;
 uses of, 13;
 vener, 16;
 wooden brick, 18.
Brickwork, 13;
 decorative, 15.
Bridge measure, 61.
Bridging, 26, 33;
 partitions, 35.
Building paper, 108;
 sites, 1.
Built-up timbers, 27;
 corner posts, 29.
- Cast-iron construction, 44.
Cement, elastic roofing, 136;
 Portland, 7, 9, 11, 13.
Chalk line, in shingling, 128, 130;
 in siding, 115.
Cheek cuts in cripple rafters, 91;
 in hip rafters, 84;
 in jack rafters, 91;
 in polygonal hip and jack rafters,
 101.

- Chimneys, 19, 20.
 Circular roof, framing of, 100.
 Circulation of air, prevented, 18;
 under porch floor, 36.
 Clapboards or siding, 110;
 laying, 115.
 Clay, foundation bed of, 2.
 Collar beams, lengths and cuts of, 92,
 93.
 Combination frame, 24.
 Common rafters, 71;
 lookout allowance, 71;
 ridge allowance, 71;
 sizes, 76;
 spacing, 76.
 Concrete, its composition, 9;
 floor, 12.
 Conductors, or downspouts, 117;
 corrugated, 117.
 Continuous air spaces, 18.
 Copper flashing, 140.
 Corbelling of brick, 17, 40.
 Corner, finish for plastering, 145, 146;
 metal, for plastering, 145.
 Corner boards, 114.
 Corner posts, 28;
 built, 29.
 Cornice, 109;
 durability, 111;
 joints, 112;
 open and box, 110.
 Counterflashing, 135.
 Covering roof, 109.
 Cricket, for flashing, 135.
 Cripple rafters, 91, 92.
 Crowning edge of rafter, 74.
 Curb plate, 103;
 roof, 102.
 Curvilinear hip rafters, 103.
 Cuts of rafters, for polygonal roofs,
 101;
 graphic method, 85.
 Damp proofing, 10.
 Deadening, 150, 151.
 Deck roof, 103.
 Diagonal scale, 55.
 Dividers, for use in scribing, 123.
 Dome roof, 70.
 Doors, fireproof, 50.
 Dormer window, 103;
 finish, 104;
 flashing, 135.
 Down draft in chimneys, 19.
 Downspouts, *see* Conductors.
 Draft, in chimneys, 19;
 in stone cutting, 9.
 Drain, blind, 12;
 cellar, 10;
 open, 13;
 open tile, 7, 10, 12;
 pitch of, 10.
 Eaves, finish of, 109, 111;
 of uneven pitches, 102.
 Engineer, 6.
 Excavations, size of, 6.
 Expansion and contraction of metal
 roofs, 137.
 Fascia of cornice, 111.
 Finial, with king-post, 100;
 use of, 117.
 Finish, eave, 109, 111;
 gable, 113;
 outside, 113.
 Fire, protection from, 51;
 walls, 50.
 Fish plate, 35.
 Flashing, 134;
 around brick chimneys, 135;
 counter, 135;
 cricket, 135;
 dormer window and skylight, 135;
 gravel roof, 140;
 slate roof, 140;
 soldering, 137.
 Flat roof, 103.
 Fitch plate girder, 39.
 Floor joists, crowning edge of, 32;
 double, 32;
 carrying headers, 32;
 mortised, 23;
 relation to girders, 28;
 relation to sills, 31;
 sizing, 32;
 spacing, 32;
 spiking, 24.
 Footing course, damp proofing top of,
 11;

- Footing course, distance below the surface of the ground, 7;
 on a side hill, 7;
 projection of, 6;
 resting partly on a ledge, 8;
 width of, 2, 3.
- Foundation beds, 2, 3;
 laid on asphalt, 12;
 laws concerning, 3;
 laying out, 3, 4;
 of slow burning construction, 47;
 underground, 9;
 walls, the thickness of, 18.
- Frame, balloon, 26;
 full, 23;
 half, or combination, 23.
- Framing of sills, 27.
- French roof, 70, 102, 103.
- Front of house, location of, 3.
- Frost, action of, 7.
- Gable, finish, 113;
 ornamentation of, 113;
 roof, 70.
- Gambrel roof, 70, 103.
- Gas, sewer, 10.
- Girders, use of, 28;
 fitch plate, 39;
 trussed, 38.
- Girts, mortised, 23;
 raised and sunk, 28.
- Graphic method of finding rafter angles, 86.
- Gravel, foundation bed, 2;
 roof, 140.
- Grounds, for plastering, 146.
- Grouting, 14.
- Gutters, circular, 118;
 cypress for, 112;
 of cornice, 111;
 pitch of, 112.
- Hair for mortar, 147.
- Half pitch roof, 68.
- Headers, brick, 15;
 in floor, 32.
- Hexagonal roof, rafters of, 99.
- Hip, lines, 132;
 roof, 70;
 shingles, 130.
- Hip rafters, 79;
 backing of, 87;
 connection with ridges, 80;
 curvilinear, 103;
 dimensions of, 79, 83;
 plumb and seat cuts, 84;
 side or cheek cuts, 84.
- Hoppers, *see* Purlins.
- Howe truss, 40.
- I beam, 8.
- Irons, stirrup, 28.
- Irregular roofs, 101.
- Jack rafters, 89;
 for polygonal roofs, 101.
- Jerry building, 8.
- Joints (masonry), horizontal and bed,
 9;
 shove, 14.
- Joints (wood), between corner board
 and siding, 114;
 cutting under, 116;
 drawbored, 23;
 flushed, over openings, 116;
 mortise and tenon, 23;
 of hip shingles, 132.
- Joists, floor, deflection of, 32;
 doubled, 33.
- King-post roof, 100, 117.
- Knotholes, covered with tin, 138.
- Land, waste of, 3.
- Lathing, breaking joints, 144;
 on wide timbers, 144;
 over door frame, 144.
- Laths, cutting, 76, 145;
 patent, 145;
 sizes, 143.
- Lattice, under porch, 36.
- Leaks around chimney, 136;
 in cornice, 110;
 in shingle roof, 129.
- Lean-to, or shed roof, 70.
- Ledger board, 26;
 fitting, 29.
- Ledges, through cellar walls, 7, 12;
 through cellar floor, 7.
- Lift in roof, 144.

- Line of common rafter, 68.
 Linings, metal, for gutters, 112 ;
 for valleys, 133.
 Lock joint of metal roof, 138.
 Lookout, 71 ;
 allowance for, 71, 77.
- Mansard roof, 70, 102.
 Mason, relation to carpenter, 20.
 Metal corners for plastering, 145.
 Metal roof, condensation on under side
 of, 137 ;
 expansion and contraction, 137 ;
 for porch, 37.
 Mill construction, 44 ;
 details of, 45 ;
 its use, 45.
 Mineral wool for deadening, 150.
 Miter box, 114 ;
 for rake moldings, 119.
 Moldings, circular, 118 ;
 rake, 119.
 Mortar, clinch over laths, 143 ;
 for brick laying, 14 ;
 for plastering, 147 ;
 hair for, 147.
 Mortise and tenon joint, 23 ;
 effect upon the strength of timbers,
 28.
 Mud, or silt, for foundation bed, 2.
- Nails, for metal roof, 139 ;
 for slate roof, 139 ;
 shingle, 129 ;
 sunk below surface of board, 138.
- Octagon roof, rafters of, 98.
 Ogee roof, 70.
 Openings in brick work, 17 ;
 studding at, 34.
 Outside finishing, 113 ;
 accuracy in, 113.
- Paint, on brickwork, 19 ;
 on wooden posts, 49 ;
 priming coat of, 115.
 Paper, building or sheathing, 109 ;
 tarred, 138.
 Partitions, brick, 50 ;
 bridging, 35 ;
 setting, 34 ;
- Partitions, vertical relation of, 34.
 Patent, roofings, 41 ;
 laths, 145.
 Piles, 2.
 Pitches of roofs, 68 ;
 cuts for different, 72.
 Pitch face of stone work, 10.
 Pitch (asphalt) for roofing, 140.
 Pitch roof, 70 ;
 hip rafters of, 83 ;
 jack rafters of, 91.
 Plancer of cornice, 111.
 Plastering, back, 150 ;
 brick walls, 19 ;
 different coats, 148 ;
 inside corner, 143 ;
 metal corners for, 145 ;
 mortar for, 147 ;
 protection of soft, 149.
 Plate, curb, 103 ;
 wall, 16 ;
 wooden, 18.
 Plumb, and level framing, 113 ;
 cuts of common rafters, 73-75 ;
 height of rafter at plate, 75.
 Pocket in roof, 136.
 Porch, construction of, 35 ;
 floor, 35 ;
 foundation of, 36 ;
 posts, 37.
 Posts, mill construction, 48 ;
 painting, 49 ;
 porch, 37.
 Purlins, position and use of, 94 ;
 angles and cuts, 95-97.
 Pyramidal roof, 100 ;
 framing, 100.
- Quarter pitch roof, 68 ;
 exposure of shingles of, 128.
 Quarter round, in corner boards, 114.
 Quilt, *see* Sheathing Paper.
- Rabbet, wash, 116.
 Rafter, common, 71 ;
 cripple, 91 ;
 crowning edge of, 74 ;
 hexagonal, 99 ;
 hip, 79 ;
 jack, 89 ;

- Rafter, length of, 74 ;
 line of, 68 ;
 measure on steel square, 54 ;
 octagon, 98 ;
 valley, 88.
- Rake, miter box, 121 ;
 molding, 119.
- Ramped rail, 37.
- Relation of carpenter and mason, 20 ;
 of carpenter and plasterer, 149.
- Relieving arch, 17.
- Repairing shingled roof, 134.
- Ribband, *see* Ledger Board.
- Ridge, allowance for, 71, 75 ;
 cut of common rafters, 73 ;
 length, 78 ;
 use, 78.
- Rise of roof, 68.
- Rock, face, or quarry face, 10 ;
 for foundation bed, 2.
- Roof, apex of, 68 ;
 boarding for sheet metal, 138 ;
 construction, 68 ;
 covering or sheeting, 109 ;
 curb, 70, 102 ;
 dimensions, 69 ;
 dome, 70 ;
 lean-to, 70 ;
 pitches of, 68 ;
 plan, laying out, 70 ;
 shed, 70 ;
 slate, 139.
- Roofing felt, 140 ;
 patent, 41 ;
 tacks, 138.
- Rosin, flux for soldering, 139.
- Rowlock arch, 17.
- Rubblework, 9.
- Run of roofs, 68.
- Saddle, for flashing, 135 ; *see* Cricket.
- Sand, for plastering, 147 ;
 as foundation bed, 2 ;
 test, 147.
- Scaffold, or staging, 109, 115 ;
 brackets, 109 ;
 use in shingling, 129, 130.
- Scantling, to straighten, 35.
- Scarving, or molding, 19.
- Scissors truss, 39.
- Scribing, 123 ;
 dividers for, 124.
- Seat cut, of common rafter, 74 ;
 of hip rafter, 83 ;
 of jack rafter, 91 ;
 of valley rafter, 88.
- Selection of timbers, 41.
- Sheathing paper, 108, 115 ;
 for deadening, 151.
- Sheeting, roof, 109 ;
 cutting, 76.
- Sheet lead flashing, 140.
- Sheet metal linings, for gutters, 112 ;
 for valleys, 133.
- Shingles, double courses, 128 ;
 dry, 129 ;
 exposure, 128 ;
 for siding, 116 ;
 hip, 130 ;
 repairing, 134 ;
 tin, 131 ;
 wide, 129.
- Shingling, 128 ;
 hips, 130 ;
 valleys, 133.
- Shoulder cut, beveled, 30.
- Side, or cheek cut, cripple rafter, 92 ;
 hip rafter, 84 ;
 jack rafter, 91.
- Siding, beveled, 116 ;
 circular tower, 122 ;
 different forms, 115 ;
 exposure, 115 ;
 mitered, 114.
- Sills, 27.
- Silt, for foundation bed, 2.
- Sizing floor joists, 32.
- Slate roof, 139 ;
 nails, 139.
- Slow-burning construction, 44 ;
 its uses, 45.
- Soldering, flashing, 137 ;
 tin roof, 139.
- Spalls, stone, 8.
- Splayed timbers, 16.
- Square, large, 6.
- Standing seam, metal roof, 137.
- Steel construction, its fire-resisting
 qualities, 44.
- Steel roofs, 137, 138.

- Steel square, board measure, 53;
 brace measure, 54;
 description of, 53;
 diagonal scale, 55;
 for laying out braces, 29;
 octagon scale, 62;
 principles and applications of the,
 56-65;
 problems in roof construction, 68-
 104;
 rafter measure, 54.
- Stirrup irons, 28.
- Stone, laying, 10;
 quarry faced, 10;
 stratified, 10.
- Stone wall, laying, 8;
 pointing, 8.
- Stonework, 9.
- Straight edge, its use in shingling, 129.
- Stretcher, brick, 15.
- Strut, use, 28;
 length, 93.
- Studs, double, 34;
 for lathing, 145;
 in half frame, 26;
 mortised and tenoned, 23;
 sizing, 33;
 spacing, 33;
 splicing with fished joint, 26;
 straightening, 35.
- Subsoil, nature of, 1;
 testing, 2.
- Surface water, 1.
- Tacks, roofing, 135.
- Tail beams, 32.
- Third pitch roof, 68;
 exposure of shingles of, 128.
- Thrust of arches, 17.
- Timbers, defects of, 42;
 large sizes, 42;
 selection and dimensions of, 41.
- Tin roof, 138;
 flat, or lock seam joint, 138;
 painting, 139.
- Traps, 7, 10, 12, 13.
- Trench, inside of foundation, 12;
 outside of foundation, 10.
- Trimmers, 32.
- Trusses, different forms, 38-40.
- Try-square, its use in scribing, 123.
- Unequal pitches, in eaves, 102;
 in roofs, 10;
 side cuts of rafters of, 102.
- Valley, rafters, 88;
 shingling of, 133.
- Veneer, ashlar, 9;
 brick, 16.
- Ventilated wall, 18.
- Wall plate, 16;
 ventilated, 18.
- Wash, in valley, 133;
 rabbet, 116.
- Water, in cellar, 7;
 proofing, 11-13;
 table, or base, 117.
- Wearing floor, over deadening, 151;
 in mill construction, 49.
- White lead, for bedding flashing, 135;
 joints doped with, 112, 114, 116.
- Windows, dormer, 103;
 mill construction, 50.
- Wooden bricks, 18;
 plate, 18.
- Wood fiber, use, 147.

COMMERCIAL GEOGRAPHY

\$1.25

By HENRY GANNETT, Geographer of the United States Geological Survey and the Twelfth Census; CARL L. GARRISON, Principal of the Morgan School, Washington, D. C.; and EDWIN J. HOUSTON, A. M., Ph.D. (Princeton), Emeritus Professor of Physical Geography and Physics, Central High School, Philadelphia.

IN this book commercial geography is presented in a simple, methodical, and logical way, to the end that its study shall be not only informative, but truly educative and worth while. The treatment is divided into three parts: Commercial Conditions; Commercial Products; and Commercial Countries. The first portion gives a clear, brief statement of the physical, social, and economic conditions that largely influence commerce in every region.

¶ The second part treats of the cultivation of the soil, and of the vegetable, animal, and mineral products that enter commerce. The great commercial staples are taken up separately, and their production, manufacture, and use described. Diagrammatic maps and graphic diagrams are presented, showing where each staple is produced, and the percentage of the world's product supplied by each of the chief contributing countries.

¶ The final and largest division is devoted to a careful description of each of the countries of the earth with special reference to its industries and commerce. Maps of the countries indicate the location of the chief industrial centers, the trade routes, and the production areas. Diagrams or tables of imports and exports, etc., are also numerous.

¶ The present condition of the world's commerce is carefully and accurately portrayed. In the text figures of absolute quantities and values have been largely avoided, because it is the relative rather than the absolute quantities that the pupil should remember. Hence the products of countries are usually given in percentages of the world's total. Absolute quantities can easily be deduced by comparing these percentages with the tables at the close of the book.

AMERICAN BOOK COMPANY

WILLIAMS & ROGERS COM- MERCIAL PUBLICATIONS

THE success and popularity of these books for business colleges, and for commercial departments of high schools, are well-known. No other series of a similar nature is so widely used, and none fits the pupil so well for the practical pursuits of later life. Among these publications are:

MODERN ILLUSTRATIVE BOOKKEEPING

Introductory, Advanced, and Complete Courses.

MODERN ILLUSTRATIVE BANKING

OFFICE ROUTINE AND BOOKKEEPING

Introductory, and Complete Courses.

BOOKKEEPING AND BUSINESS PRACTICE

THREE WEEKS IN BUSINESS PRACTICE

PRACTICE SYSTEM OF BUSINESS TRAINING

FIRST LESSONS IN BOOKKEEPING

NEW INTRODUCTORY BOOKKEEPING

NEW COMPLETE BOOKKEEPING

ADVANCED BOOKKEEPING AND BANKING

MENTAL COMMERCIAL ARITHMETIC

BUSINESS ARITHMETIC

MOORE'S NEW COMMERCIAL ARITHMETIC

GANO'S COMMERCIAL LAW

TEST QUESTIONS IN COMMERCIAL LAW

MILLS'S MODERN BUSINESS PENMANSHIP

NEW PRACTICAL GRAMMAR

BELDING'S COMMERCIAL CORRESPONDENCE

STUDIES FOR LETTERS

ENGLISH PUNCTUATION

PITMANIC SHORTHAND INSTRUCTOR

SEVENTY LESSONS IN SPELLING

TEST LESSONS IN SPELLING

NEW CIVIL GOVERNMENT

DESCRIPTIVE ECONOMICS

AMERICAN BOOK COMPANY

ADVANCED ARITHMETIC

\$0.75

By ELMER A. LYMAN, Professor of Mathematics,
Michigan State Normal College, Ypsilanti

THIS book meets the requirements of secondary and normal schools. In its preparation the author has aimed to make the work a study of the fundamental principles of arithmetic, and thereby emphasize the disciplinary value of the subject, and at the same time to apply these principles to the solution of practical business problems. To this end such methods as are used in the best commercial practice are emphasized throughout the work, and obsolete methods and problems are carefully excluded.

¶ The exercises have been selected largely from actual business transactions, and nearly all of the problems in the application of percentage have been secured from business houses, or reviewed by representative business men. The chapters on banking, and stocks and bonds, give information of a practical character which, though indispensable to a proper understanding of the subject, is rarely found in text-books.

¶ In order to economize time, pupils are encouraged to use every practical labor-saving device known to the science of arithmetic, but so-called short processes, which are complicated or cumbersome, have been carefully avoided. The use of checks is also strongly recommended, because it contributes greatly to accuracy in results, and cultivates a spirit of self-reliance.

¶ In addition to the special methods for solution given in connection with the various subjects, a chapter is devoted to the general method of approach to any problem. This offers pupils much helpful advice in attempting the solution of problems of a miscellaneous character, such as are given in examinations. Attention is also called to the historical notes, to the treatment of graphical representations, and to the chapter on approximate results.

AMERICAN BOOK COMPANY

COMPOSITION-RHETORIC

(Steps in English Series)

By THOMAS C. BLAISDELL, Ph. D., Professor of English,
Michigan State Agricultural College

\$1.00

THIS book, which aims to teach young people to write effectively, is suited for use in any secondary school. Its ingenious method of treatment, its fresh and interesting character, its great simplicity and suggestiveness, will prove stimulating and inspiring to every student. The work lays a foundation for the appreciation of literature.

¶ Models from the master writers are furnished and pupils are asked to use their own experiences as working material. They are taught to write accurately by being trained to recognize, and thus to avoid, their errors. Principles are studied only when they are encountered, each pupil being obliged to learn merely those of which he is ignorant.

¶ The most important qualities which characterize literature are each taken up in turn and considered. Selections from the works of famous writers are inserted at frequent intervals for purposes of illustration, and it is shown by analysis how they appeal to the feelings, and why they attain the various results necessary to an interesting expression of their thoughts. The student is taught that literature is full of suggestion, and he is made to understand the various devices by which an author conveys this suggestion.

¶ When these methods have been discovered and sufficiently illustrated, the learner is asked to use them in writing about familiar experiences. In these exercises, which are very numerous, while accuracy of expression is sought, fluency of expression is considered of chief importance. At first compositions of only a few paragraphs in length are required, but later the character sketch, the short story, and the essay are taken up. Letter writing is emphasized throughout the book.

AMERICAN BOOK COMPANY