

# CANADIAN MOTOR, TRACTOR AND IMPLEMENT TRADE JOURNAL

Published Monthly by THE MACLEAN PUBLISHING COMPANY, LIMITED, TORONTO

MONTREAL, Southam Bldg. WINNIPEG, 1103 Union Trust Bldg. VANCOUVER, 39 10th Ave. West. LONDON, ENG., 88 Fleet St., E.C. 4. NEW YORK, 111 Broadway. BOSTON, 734 Old South Bldg. CHICAGO, 1401 Lytton Bldg

VOL. II, No. 1

TORONTO, JANUARY, 1920

Subscription Price  
\$1.00 Per Year

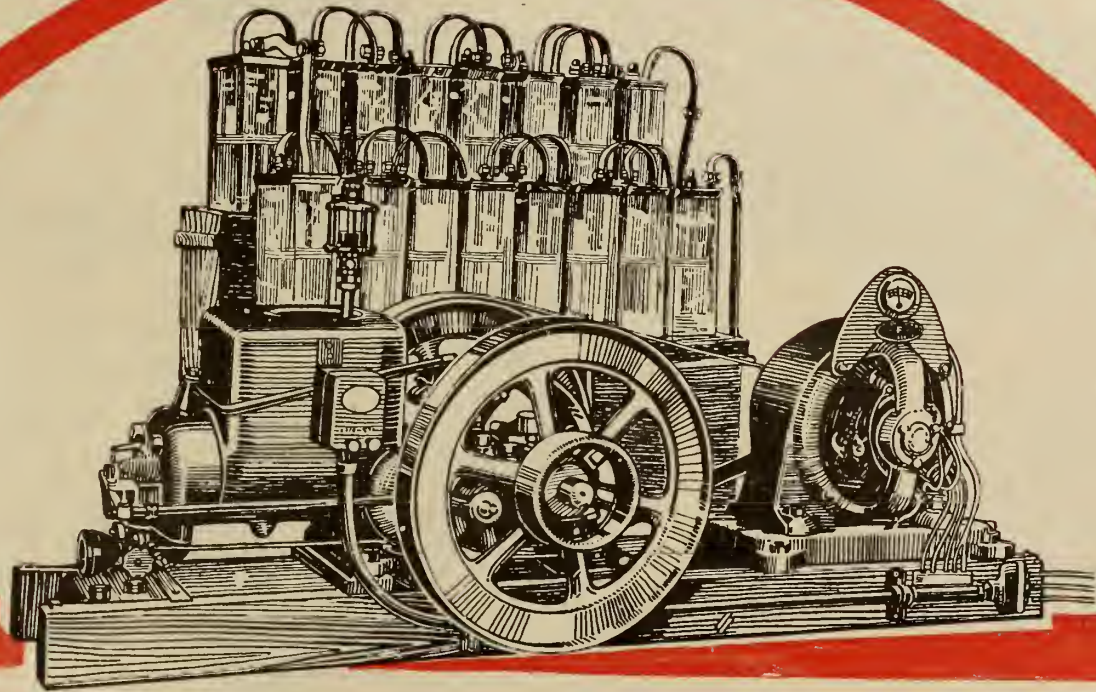

Made in 40, 65, 100 and 200 light sizes

## The "F" Power and Light Plant Opens Exceptional Sales Possibilities in Every Rural District

To sell the thousands of rural dwellers, in communities not supplied with electric power, and the tens of thousands of farmers who need power and light on their farms, we have created an intensive marketing plan. This selling campaign will enable agents for Fairbanks-Morse "F" Power and Light Plant to make thousands of dollars each year.

Representation is wanted in every part of Canada, and men who are capable of handling a business running well into five figures have an opportunity—now—to secure this exclusive agency.

Agencies are being placed daily, so that it will be advantageous to you to get the particulars of this proposition without delay.

### The Canadian Fairbanks-Morse Co., Limited

Fill in the coupon on opposite corner and send to our nearest branch, if you want a business which is interesting as well as profitable.

St. John  
Toronto  
Saskatoon

Ottawa  
Winnipeg

Quebec  
Hamilton  
Calgary

Victoria  
Regina

Montreal  
Windsor  
Vancouver

The Canadian Fairbanks-Morse Co., Ltd.  
Please send me particulars of the "F"  
Power and Light Plant Agency.

NAME.....  
ADDRESS.....





## The Wedge Does It

Back of *WedgeRite Piston Rings* is a principle used for ages by woodmen in splitting giant trees. The advance agents of civilization know the value of the *wedge* and increase their efficiency by using it. In adapting the *wedge* principle to the construction of piston rings we have solved one of the most troublesome problems facing the motorist. The *WedgeRite Piston Ring* is made up in three sections—two outer or bearing rings and a wedge-shaped ring of untempered spring steel. This spring steel ring is slightly larger than the two outer rings and when placed between them it exerts a constant outward pressure, wedging the outer rings apart and pressing them firmly against the groove walls. *WedgeRite Piston Rings* excel because of this exclusive feature.

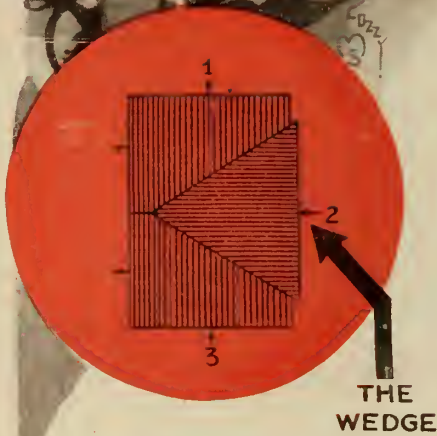

### CROSS SECTION OF RING

1. Section pressing outward and upward.
2. Spring section of ring.
3. Lower outward and downward section.

### ILLUSTRATING THE WEDGE PRINCIPLE

The Wedge principle employed in the making of *WedgeRite Piston Rings* is shown in the accompanying drawing. Its superiority, measured by its ability to expand in WIDTH as well as in diameter, means utmost satisfaction for motorists.

## More Power—Smoother Operation

*WedgeRite Piston Rings* are power boosters for the farm tractor. Running along the level, over rough ground, or up an incline, *WedgeRite Piston Rings* hold tight giving the engine every ounce of power generated. You cannot do a better stroke of business than sell a farmer friend a set of *WedgeRite*. They will save him money and give him more and smoother power. He will want a set on his motor car, too.

Explain to your customers the principle of *WedgeRite*. It is so obviously correct any user of gasoline power will see it. If you are not wised up yourself, write us for full information.



**WedgeRite**  
PISTON RING  
COMPANY

LIMITED

92 Notre Dame St. E., MONTREAL

*Sold by all Jobbers*



Sure  
Satisfaction

# Lister

POWER ON THE FARM

Good  
Profit

## The Quality Line of Farm and Dairy Machinery

Users speak well of Lister lines everywhere.  
They are your friends and business boosters.

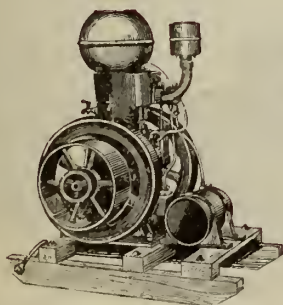

### The "Lister" Engine

The modern farmer wants the "Lister" Engine—because in efficiency, workmanship and equipment it is away ahead of all others.

Compare the "Lister" with any of its competitors and its superiority will at once be obvious to you.



### THE "LISTER" MILKER

Has proved its wonderful efficiency and exceptional qualities in actual operation by thousands of farmers during the past ten years. Can be used on all grades and breeds with entire safety.

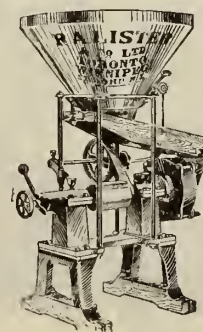

### The "Lister" Grinder

Guaranteed to do more work (whilst grinding as fine) than any other grinder made or offered for sale in Canada, the same power being used and all other conditions being equal.

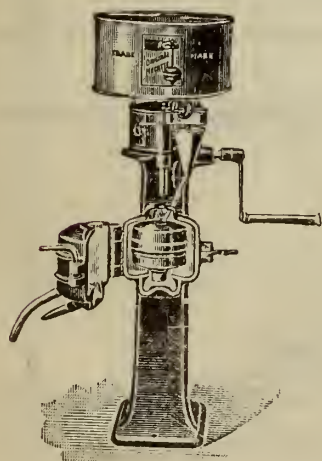

### The "Melotte" Cream Separator

The Original Melotte—a marvel in skimming efficiency, ease of operation and long life.

### The "Premier" Cream Separator

British made—and its service shows it. Easy to operate. Easy to clean.

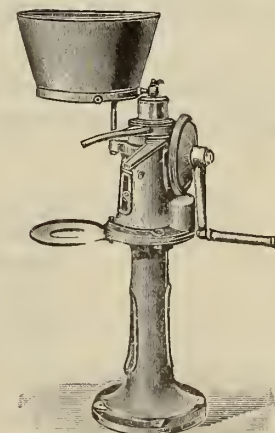

### "AVERY" TRACTORS

"Avery" Tractors are built in seven sizes—a size for every size farm—and sold at popular prices.

Write us for the "Lister" Agency proposition and full information.

**R. A. LISTER & CO. (CANADA) LIMITED**  
58-60 Stewart Street, TORONTO

Also at Wall Street, WINNIPEG



# YOU'VE HEARD OF THE NISCO? SURE!

It's the **BIGGEST SELLING SPREADER** in the **WORLD!**

## WHY?

Because it is in a class by itself in performance and exceptional service.

It's the biggest money-maker for the farmer,---the agent,---and the implement dealer who sells it.

Isn't this a cracking good line for you to get next to?

**THERE IS BIG MONEY IN IT FOR YOU**

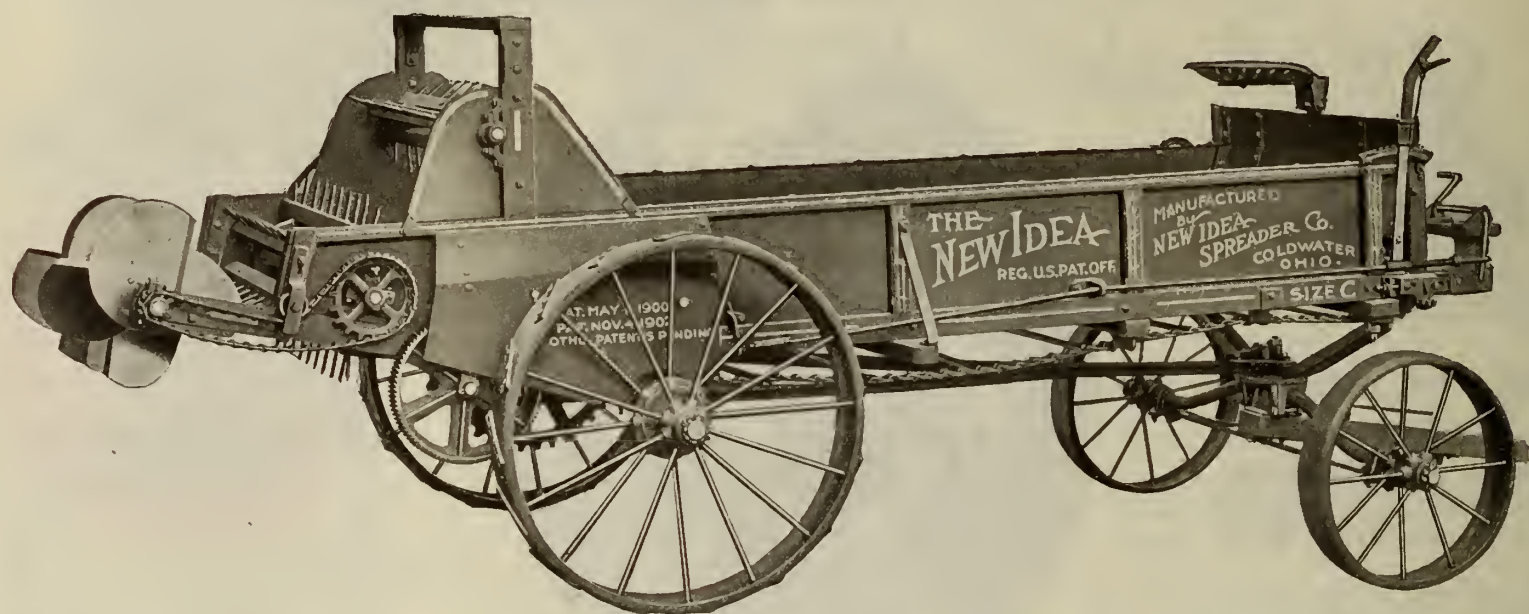

Indications show that this year will be a record-breaker for Spreader sales.

Spreader profits are generous—Here's the chance for you.

You want the Spreader that will bring the most money into your pocket. Isn't that so?

Gilson Nisco Spreaders are making thousands of dollars for other dealers. Why not you?

They are easy sellers because they dominate in service, quality and satisfaction.

The Gilson Nisco is the accepted standard of Spreader value.

Here are a few outstanding points:—

The original wide spread  
Improved feed  
Low draught  
**BIG DEMAND**

No complicated parts  
No gears  
Thoroughly standardized  
**NO EXPENSIVE REPAIRS**

They advertise themselves—one in your locality will bring many sales. You will make the profit on them all. The Gilson Nisco is in the public eye. You will pocket the cash. It's no trick to sell a Gilson Nisco.

Our entire organization is behind you. At the present time we are spending thousands of dollars on the biggest advertising campaign ever carried out for Spreaders in Canada

Let's get together. It's a chance you can't afford to pass up. Do not fail to write us regarding our agent's proposition.

Better still, send in for sample Spreader. We are making a specially low price on all machines for demonstrating purposes.

**ANSWER THIS ADVERTISEMENT IMMEDIATELY**

**GILSON MFG. CO., LTD.,** Factory and Head Office, Dept. C, Guelph, Ont.  
Branch and Warehouse, 354 Elgin Ave., Winnipeg, Man.





*Hard going here, but -*

*Easy on a TRACK, the Cletrac way*

## Sell Cletracs Now

You can sell Cletracs all Winter long.

The farmer is through with his horses for the Winter. They're not working—but the farmer is still feeding them costly feed every day and doing his horse chores morning and night.

Careful estimates prove that it takes the crops of at least five whole acres, the average value of which is \$297.00, to keep one horse one year.

The Cletrac easily replaces six horses with their yearly feed bill of \$1,782.00.

Get the farmer to sell his horses and buy a Cletrac with the proceeds.

He'll keep the Cletrac busy in Winter clearing the wood-lot and the roads, sawing wood, grinding feed and doing other Winter chores. In Spring, he lets go with the Cletrac—does 30 days' work in a week and gets a bigger yield per acre.

The Cletrac is sturdy, powerful, economical, easy to operate. Runs on its own tracks—turns short—goes everywhere. Burns coal oil (kerosene), perfectly.

For the farmer, the Cletrac is a big-paying, all-year investment. For you, it is a ready, profitable, all-season seller.

Don't wait for Spring. You can sell Cletracs now—in Winter.

**If you are not a Cletrac dealer, you're losing a chance for all-year profitable sales. Write for our proposition to-day.**

**THE CLEVELAND TRACTOR COMPANY  
OF CANADA, LIMITED**

*Head Office:*  
WINDSOR, ONTARIO

*Western Sales Branch:*  
REGINA, SASK.



GET IN ON THE

1920  
Series

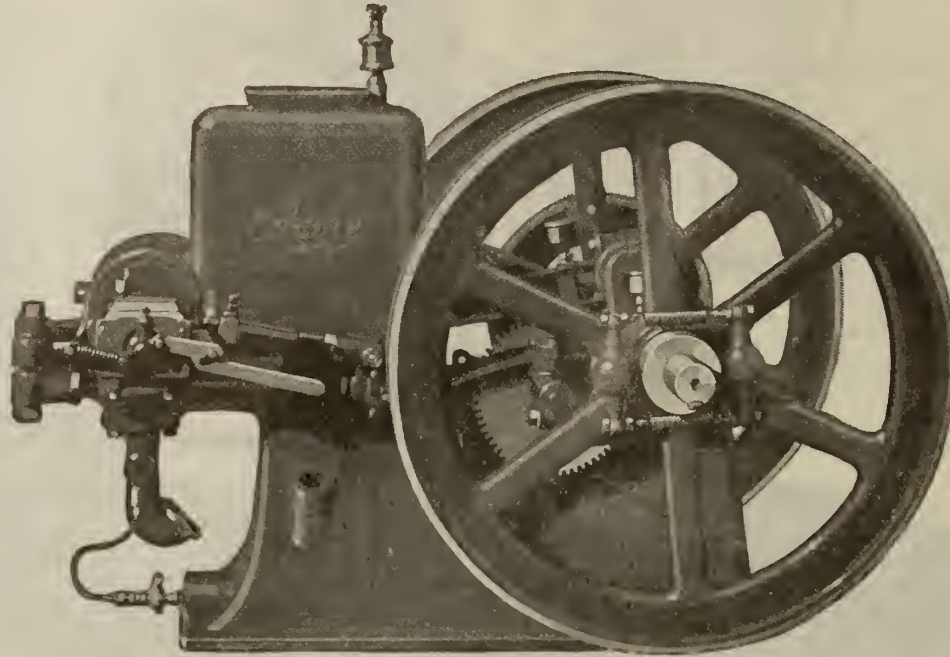

1920  
Series

QUALITY - QUANTITY

PRODUCTION OF

# ACME ENGINES

*Canadian Made for Canadian Trade*

Full range of sizes between 1<sup>3</sup>/<sub>4</sub> hp. and 15 hp.

### A FEW REASONS WHY

YOUR CHOICE SHOULD BE THE  
ACME

*Extra Heavy* Weight and Rugged Design ensures  
Stability and Power of Endurance.

*Will Develop* ratings far in excess of specifications.

*Have Fewer* moving parts and greater accessibility.

*All Parts* are interchangeable.

*Start Easier* regardless of climate.

*Wide Range* of speed control.

*Perfect Balance* enforced by heavy fly-wheels.

*Economy* ensured by special carburetor

*Equipped* with Webster Tri-Polar Oscillating Mag-  
neto, and all modern improvements.

*Ideal* in lines and finish.

*Fourteen Years'* Record for durability and satis-  
factory service behind them.

*Backed* by a jealously guarded reputation.

### THERE ARE OTHERS

*Write us for "POWER," our 1920 Catalog*

Acme Engine Plant has obtained 20,000 extra feet of floor space for 1920 output.  
Acme Foundry Division is doubling its capacity for 1920 demand on Engine Castings.

*Some Good Territories Are Still open*

*Yours May Be One*

## FISHER-WILKIE, LIMITED

SANDWICH, ONTARIO



# NOW Is The Time To Tell Farmers About The Famous John Deere Low Down Manure Spreader and "Waterloo Boy" Kerosene Engine

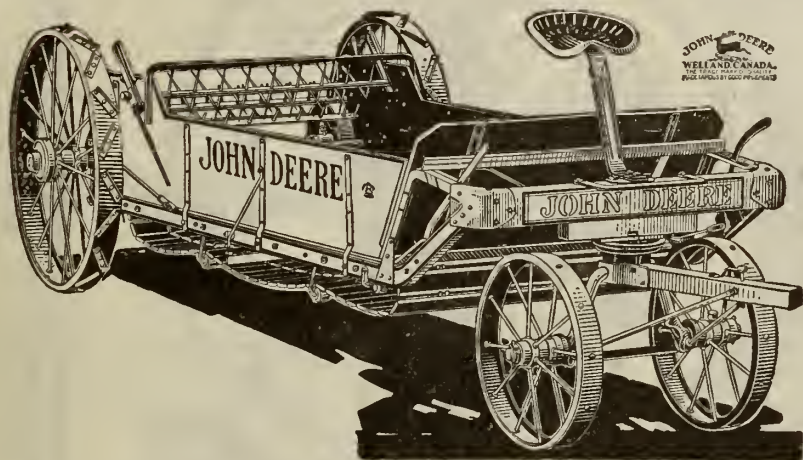

## John Deere Low Down Manure Spreader

Just compare the John Deere Low Down Manure Spreader with spreaders of other makes. Note the many exclusive features of the John Deere—its many points or superiority—the ease with which it is possible to interest farmers and to sell the John Deere.

The John Deere has revolutionized the art of spreader building.

The John Deere Low Down Manure Spreader is the only gear driven spreader on the market. The gears are covered—they are watertight and cannot freeze or become clogged. There are no clutches or chains to create trouble. It is easy to assemble—easy to load, and easy to operate.

The John Deere is the only spreader with the beater on the axle—a feature that is covered by basic

patents. It has high drive wheels, insuring proper traction and light draft. It is simple in construction, having nearly 150 less working parts than other spreaders. No adjustments, nothing to get out of order. It has a revolving rake—the manure does not bunch and clog the beater. It makes for uniform spread. These and other features make it a wonderful sales proposition.

## "Waterloo Boy" Kerosene Engines Stationary or Portable

The Waterloo Boy gives the greatest power from the cheapest fuel. It is an original kerosene engine—it is not a gasoline engine adapted to kerosene. That means a lot to you, the salesman.

The Waterloo Boy is easy to operate. It is long-lived and absolutely dependable. It is simply and carefully proportioned; it is equipped with Oscillating Magneto and requires no battery; the magneto is built in—it is not an attachment. Simple carburetor gives perfect fuel mixture at all loads. There are few working parts and all accessible.

requirement. Built in sizes from 2 to 25 H.P., stationary or portable. It is guaranteed to give satisfaction under extreme conditions.

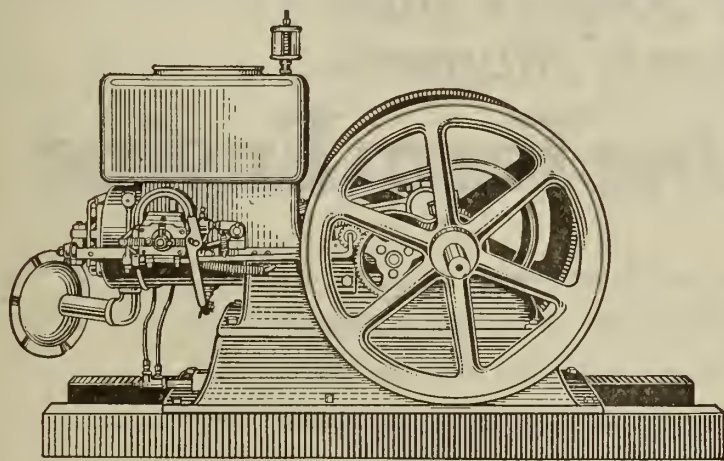

The Governor is of high speed, centrifugal type, positive gear driven, with machine cut gear. The Waterloo Boy is a powerful, sturdy and economical engine—a size and horse-power to meet every

### A GREATER INCOME FOR YOU

Put your sales energy back of the John Deere line—it goes farthest in creating substantial business for dealers everywhere. Remember this: John Deere Equipment is sold through John Deere dealers only. The John Deere sales proposition is decidedly liberal, free from red-tape and highly profitable. We want live dealers to work with us; such men will become a real part of a large and thoroughly modern organization.

Get the utmost out of your sales ability—sell John Deere equipment. Write us now regarding our sales proposition.

**JOHN DEERE MANUFACTURING COMPANY LIMITED**  
W E L L A N D . . . . . O N T A R I O



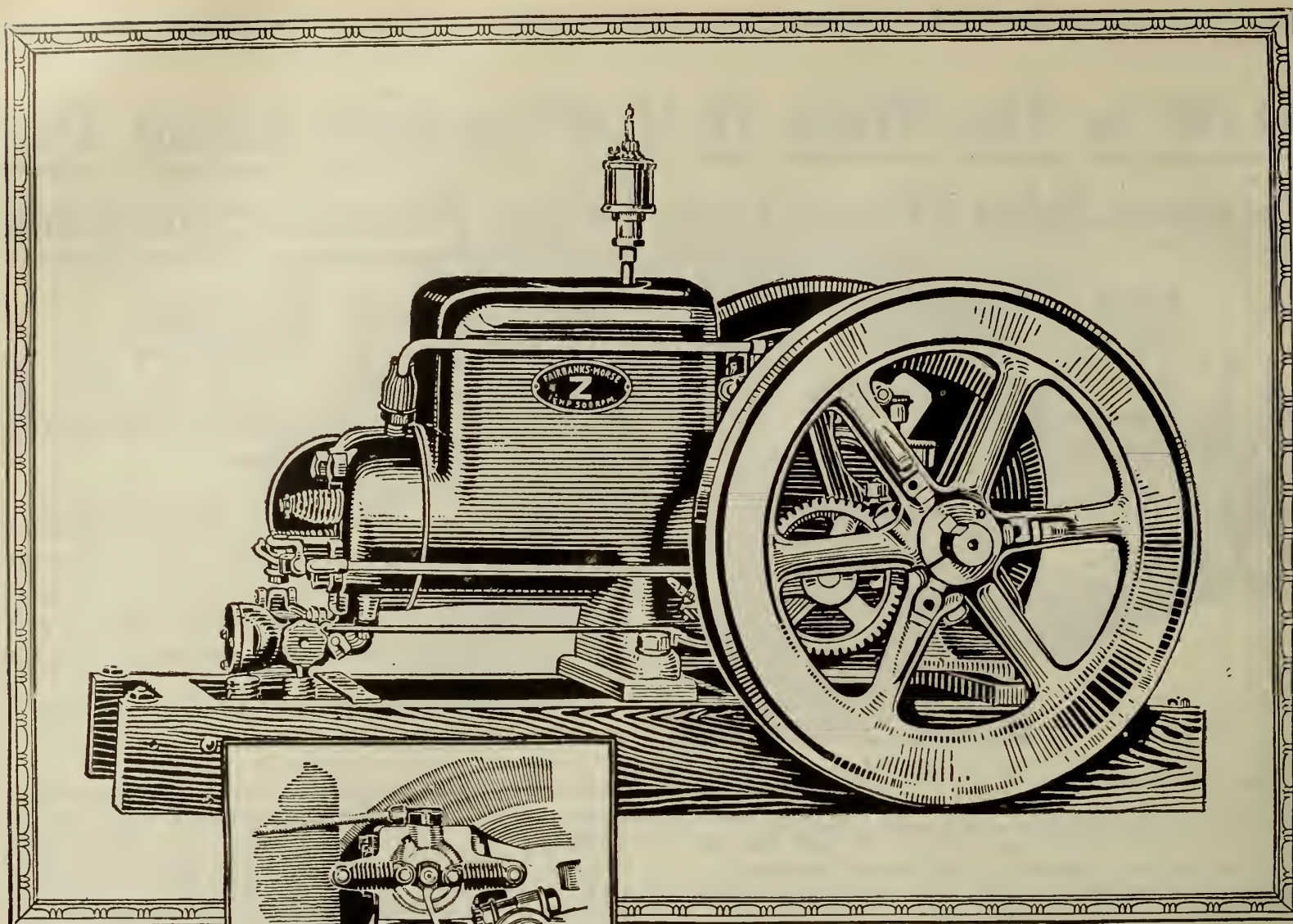

*Fairbanks-Morse  
"Z" Engine with  
Bosch Magneto*

## Now-There is Only One Farm Engine

JUST think of the famous "Z" Engine with a Bosch high-tension, oscillating magneto—which delivers a steady succession of hot, intensive sparks. ¶ Every farmer in Canada should at once call on the nearest "Z" Engine dealer and see the result of this recent epoch-making combination—FAIRBANKS-MORSE "Z" ENGINE WITH BOSCH MAGNETO. ¶ Mechanical perfection, plus power—and right price—to date sold the "Z" Engine to over 250,000 farmers. ¶ This quality and quantity production enabled us to contract for a large proportion of the extensive Bosch facilities for making this one possible "Z" betterment, which establishes a new farm engine standard. ¶ And all Bosch Service Stations throughout Canada will assist our dealers in delivering maximum engine service.

*The Canadian*

MADE IN TORONTO, CANADA, BY

# Fairbanks-Morse

*Co., Limited.*

HALIFAX

ST. JOHN

QUEBEC

MONTREAL

OTTAWA

TORONTO

HAMILTON

WINDSOR

WINNIPEG

SASKATOON

CALGARY

VANCOUVER

VICTORIA



# CANADIAN MOTOR, TRACTOR AND IMPLEMENT TRADE JOURNAL

Volume 2

TORONTO, JANUARY 5, 1920

Number 1

## Implement Dealer **DROPPED \$700** His First Season

*But He Got It All Back In Two Weeks Next Season*

**T**HERE are primarily three reasons for whatever success I have had in selling implements. These are:

Quality in the goods I handle;  
Intelligent Service; and last—but most important—  
Hard Work!"

So said J. E. Nesbitt, implement dealer of Newmarket, when interviewed by M. T. I. We found Mr. Nesbitt a very keen and wide-awake business man, who has thought out a policy for himself and has followed it consistently. He started selling implements in Newmarket nine years ago and has, with hard work, business ability and audacity, built up a very extensive and prosperous business.

"When I started in at Newmarket nine years ago, I recognized at once that I had no cinch of a job," said Mr. Nesbitt. "I was breaking in on territory that had been—to all appearances—pretty well canvassed and sold by a dealer further up the street. This man was doing all the business. However, I had to begin somewhere, so I hired a rig by the day and commenced operations. I sold a few machines but not enough to cover expenses; in fact, that first season I went in the hole \$700.

**A**LTHOUGH I lost money that season, I didn't throw up my hands and howl to the skies like Jeremiah; instead, I got my brain working and very soon evolved a plan with which I hoped to break through on the right side.

"My plan was to arrange with the Deering Co., to ship a carload of spreaders when the spring season opened, and have them send an expert—at my expense—to assemble them. This was done, and when the farmers came to town one day that spring, they were amazed to see twelve gaily-painted spreaders, assembled and arranged in a certain way at the Newmarket depot. I had them placed in such a manner that the farmers were obliged to thread their way through them.

"I hired a man and posted him on the ground with orders to jot down in a book the names of the farmers who took any interest at all in the display.

"Believe me, that little exhibit caused a stir, and was some 'ad.' I remained at home, leaving the man I had hired to gather all the information he could. As he was working on the quiet he was able to mix with the farmers and hear their talk.

"Farmers on all sides were asking questions about the line-up, and 'who this new man Nesbitt was.' Of course my man was right on the spot to give all the details concerning the 'new man.'

**T**HE spreaders were left assembled for about a week, then I got busy canvassing the names we secured. For some days I sold at the rate of three spreaders a day, and, with the help of one of the manufacturer's salesmen, was able

at the end of two weeks to sell three carloads—36 spreaders—cleaning up \$900. That overcame my first season's deficit, put me on my feet and sent me on the road to success.

"Since that time, I have been gradually adding to my line, till, to-day, there isn't an implement for farm use that I don't handle.

"I have a certain cast-iron plan which I follow and only deviate from it under exceptional circumstances. When I take on a new line, I first of all examine the stability of the manufacturers behind the goods, thus protecting myself and my customers.

"I buy everything from the manufacturers for cash and take advantage of the discount, which, in a year's time, amounts to a considerable sum.

**I** ALWAYS impress on my prospects the advantages of buying for cash—even though it may mean getting a loan from their bankers. If the man is worth his salt, I have always found that such loans are easy to procure. On the other hand, if for any reason a man doesn't care to purchase a loan, and decides to buy on terms, I say to him:

"Well, Bill, if you want some time, I can take care of you from here, and I am the worst man you will have to deal with.' By buying everything for cash myself I am in a position to do this.

"I keep samples on hand of most of the lines I handle, first to show the customer what he is buying, and if necessary to give a demonstration. It is no use trying to sell something if you can't demonstrate what that something can do!

"There is nothing like keeping up the interest, and bringing your goods constantly before the public, if you want to succeed in selling.

"I do this by advertising in the local papers, by letters, and posters scattered through my territory.

"My system of advertising in the local press is this: "For two weeks I will run one 'ad.' describing one article; for instance, if it is a tractor I wish to advertise, I have that in and that only, with a cut to illustrate it. When this has run two weeks I change it for something else until I have gone through all my lines. Of course this plan is modified slightly to meet seasonal requirements.

**I**N going after sales I study my prospect, the conditions he is up against and endeavor always to find out what machinery will help him best. It is bad business to force on a man an article for which he has little or no use.

"I always show a prospect in facts and figures why he should buy my article; and try to make him see that he can't afford to be without it.

"After I have sold a man I make a point of a prompt delivery. This leads me to a very important phase of selling implements and this is: SERVICE!

"There is much talk these days of service; how it should be given and who should pay for it, but it is up to each dealer to settle these points for himself. Personally, I keep two service men to look after my work.

"Whether a prospect should pay for service, or whether he should get it free, depends on circumstances. I don't weigh the paying point too seriously; my business is to please my customers and make them all my friends.

"Talking about service and pleasing customers reminds me of an incident that happened to me some time ago. One of my customers came to me one day and said:

"Jack, I want to buy a separator and I want such and such a make, can you get it for me?"

"I didn't handle the separator he wanted, and told him so, but I said I had one which I thought was just as good. After I demonstrated the machine to him he was satisfied and bought it, and I had it delivered. In a week or so he had the opportunity of comparing his machine with the machine he wanted to buy originally, with the result that the other machine, in his estimation, was much superior to his own. He came right down to me with his story. He was certainly dissatisfied with his separator. So after discussing the merits of the two machines with him, I said:

"Look here, Bill! You go back home, put that separator on your rig, throw something over it and bring it back to me!"

**A**WAY he went, and like the good sport he was, drove a round-about course when coming in so that the man 'up street' wouldn't see him bring back that separator. I gave him back his money and told him to go to the other man and buy



J. E. Nesbitt's premises, Newmarket. Note the slope at right of photo. Under the level of main entrance is the garage end of business. There are few implement dealers more alive than "Jack" Nesbitt.



the separator he wanted. By that act I made one of my best friends. In fact he has acted on his own initiative as a sub-agent for me. I may say I lost no time in getting the agency of that other separator.

"I have a host of self-constituted sub-agents among my prospects who, because I tried to please them in every way, are eager to return the compliment by helping me all they can.

"FOR years it was the custom with me in the spring to have the customers I had sold during the winter come in on a certain day for their goods. In they would come from every direction with great noise and clatter. After loading up the rigs—about 70 in number—I entertained them all to refreshments. And

if they weren't the pleased bunch! It was a great sight to see that long procession moving out of the town.

"I think out the best policy to pursue in my business and rigidly adhere to it. I am opposed to begging for business. The man who is sincere and has confidence in the lines he handles will have no need to beg, business. Persuasive power—a thing you hear much about these days—matters little if you can't show facts and figures.

"I never load a man down with a great amount of detail about his machine; I tell him enough so that he can run it intelligently. No farmer wants a machine if he thinks it is so complicated that only an expert can handle it. Go easy on the details, but emphasize

fully the ability of the machine to do the work it was designed to do!"

MR. NESBITT, besides handling farm implements, runs a garage, and handles repairs, automobiles and accessories. He has the agency for the Nash, Overland and Dodge cars. He also handles water systems, power- and hand-washers, and pianos and grafanolas.

In all his lines he is successful. He believes that work, service, sincerity, and then more work will bring success in any line of endeavor. When the M. T. I. representative was leaving, Mr. Nesbitt said: "Yes, sir, it is a great game! A splendid game, and I love it!"

There is the secret—ENTHUSIASM!

# SELLING WINTER ACCESSORIES

*Sell Your Customer What He Really Needs; If He Doesn't Know, Tell Him*

THE successful selling of seasonable accessories depends upon two things, according to Alex. Renaud, of the Renaud Motor Supply Co., Montreal:

1. Stock up with what you really want.
2. Sell the customer what he really needs.

If the customer doesn't know what winter accessories he needs, it is up to the dealer to advise him. Often an auto owner is too inexperienced, and should be given useful tips by the accessory dealer.

Mr. Renaud has been selling accessories on his own account for the past six years. Each year has recorded an increase of turnover. And this year's records, already, in those lines that may be styled as "Winter Accessories," prove that the business is increasing. And this, let it be emphasized, when there are more dealers handling the lines than ever there have been, since automobiles became so numerous as to demand that many dealers handle repairs and supplies for the upkeep of these cars. "We are all getting good business," continued Mr. Renaud, "and there is a big future ahead.

"For \$2,000 or \$2,500," said Mr. Renaud, "a good stock of accessories can be bought. And the best way, if the dealer has confidence in the salesman, is to let him select a stock that will suit his needs. Of course this depends upon the salesman being fair with his customer."

There is much soundness in this suggestion. For the auto dealer who has not handled accessories will not know just what he requires, while the travelling man, having sold others along the line for several seasons, and being conversant with their sales, is in the best position to help the dealer in his selections. Such a plan, if adopted, would quite probably overcome a stocking of unsaleable lines which would only keep good money tied up. Therefore, even a somewhat more modest beginning could be made than that suggested, and the extent of stock will be determined, quite naturally, by the district in which one is located.

THE use, and quite naturally the sale, of automobiles is increasing every year. "Oversold." What a distasteful word that has come to be for the man who wants stock; for the man who has the orders either in hand or to be had for the going after; for the live-wire merchant, who has, indeed, had few quiet months during the past two or three years! And, from the best-authenticated sources, the demand will not only continue; it will increase, that is, if the capacity of the motor car makers can be so increased as to meet the seeming unceasing demand.

Up to the end of December, 1918, the number of cars throughout Canada was over a quarter of a million; in exact numbers, 269,727. It is estimated that not less than 100,000 cars were added during the present year, 1919. With even a fair increase added to this in 1920, it will be no length of time before Canadians are the owners of half a million cars. Think of it! What does this mean to accessory dealers? It means, in a sentence, that there will be an enormous and increasing demand for accessories, and it is the man who goes after this business who will acquire the profits.

Mr. Renaud, in developing his business for automobile accessories, has issued what he calls a "Winter Catalogue." This contains illustrations of such lines as are required by the auto owner. Mr. Renaud states that, with three or four exceptions, the lines shown were real necessities.

Aside from tires, which are always seasonable, there will be a big sale for warm robes, as in our Canadian climate these are indispensable. Non-skid chains will be a big seller, also lifting jacks. An extensive demand is bound to develop for trouble lamps and bulbs for these, and for headlights, tail-lights, etc.

A line of radiator covers, the extent of which will depend upon the probable trade to which one may cater, will prove to be good profit-yielders. Then follow windshield wipers, side, rear, and front curtains, celluloid for windows, electric radiators and foot warmers, charcoal heaters, driving gauntlets, packings, oilers, etc.

One of the best sources of turnover is that afforded by oils. The dealer can easily secure a reliable line of oil which will prove good advertising, that is, if he can offer his customers a brand of oil which will be of uniform good quality. Graphites, non-freeze radiator compounds, etc., all come under this head. And there are, in addition, the many kinds and grades of tools, including pliers and wrenches. Added to these, packings and various nuts, washers, copperaskets, and many other staple, as well as some special, lines will be in regular and steady demand.

IN getting after winter accessory business, two things are very important. Mr. Renaud, himself, realizes the importance and value of good window display, and he spends a considerable amount of money in this way. If you have the prospects passing your window, that's the time to seek their interest; the window is an excellent medium, and as you must pay rent for the store, make its "face" so attractive that the buyer will have the very best excuse in the world for entering your store and making the purchase.

Then there is advertising. This must be made as effective as is possible, and the plan of hitching up to this "Winter Accessories" caption will appeal to many. To use the words of Mr. Renaud again:

"Some think that we ought to create a demand on the part of the consumer, and then they—the dealers—will buy, instead of the dealer getting out and showing the car owner what he needs. There are many things that can be sold and which will readily meet the wishes of the car owner if he be shown them. Through pointed, effective advertising, great improvement of sales can be effected, and it is now the eleventh hour, so to speak, if the dealer has not already mapped out his campaign."

Mr. Renaud is one of those who is convinced that, in the immediate future, lies an opportunity for the aggressive dealer to exert his initiative, and to secure business for the going after which will yield excellent profits. There has been great growth in Quebec and Eastern Ontario, Mr. Renaud says; and there should be a growth in every part of Canada. The accessory dealer has a mine-field before him which only needs consistent, relentless mining, to reveal the hidden profit nuggets.

## M.A.T.A. SHOW, JANUARY 17-24

ALL is merry and bright in Montreal Automobile trade circles now; peace prevails, but not quietness, for there's an immense bustle going on just at present as the Montreal Automobile Trade Association prepares for the big show which is scheduled for January 17 to 24, inclusive, in the Grand Palais, Sherbrooke Street East, near St. Denis Street.

The Canadian manufacturers, distributors and dealers in pleasure and commercial cars, tractors, accessories—and even aeroplanes—will be present en masse. This will be the big event of the auto year in Quebec, and as all the space has long been booked up there is no doubt as to the success of the affair.

A list of exhibitors has been received at the M. T. I. office, with enough names to fill about two columns. It is expected that manufacturers or distributors of cars new to the Canadian trade will be represented, and in addition several lines of accessories new to this country will be shown. Every automotive dealer who can get there should visit the M. A. T. A. exposition.

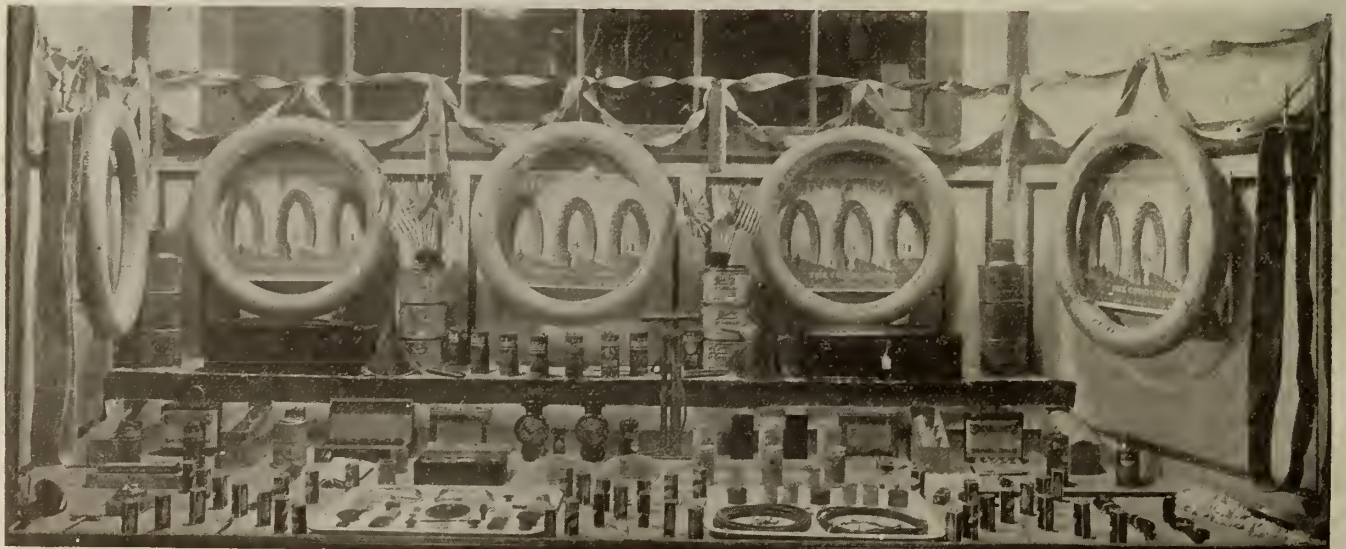

A window display of auto accessories carries a real interest for every car owner. Do you know that there are 9,000 cars being turned out every day and that the auto factories are still away behind with orders?



# Stories of Implement Dealers' Successes

## Doing Ninety per cent. Cash Business

"NINETY per cent. of our 1919 business has been for cash."

This statement, which, until very recently, would have been almost incredible in the implement business, and even now is all too rare, is made by Hartman and Card, of Napanee, Ontario, who handle farm machinery and supplies. According to their letter-head, this includes also: Buggies, cutters, wagons, pianos, farm tractors and Gray-Dort cars.

Knowing what a large proportion of their business is closed for cash, it is not surprising to learn that this agency is amongst the most successful of the I.F.C. agencies in Canada. Mr. Hartman was asked by the M.T.I. to put into a nut-shell some of the reasons for the success attained by Mr. Card and himself. His five rules for doing business are as follows:—

"1.—We try to do a square business with the customer, as well as with the company, by treating him just the same after we sell him as before.

"2.—We endeavor to handle only the best lines of goods on the market, and we make a point to put them into first-class condition before they are handed over to the purchaser, as well as to keep them in A-1 shape after they are sold.

"3.—We try to show every prospective customer where he can save money and labor by buying—and by buying from us.

"4.—We have just one price to all—and that is the list price. This prevents any hard feelings, or friction, or talk that we have a 'preferred' list of customers.

"5.—We always do just what we agree to do, and never promise anything that we do not expect to make good on. It is a fatal mistake to promise more than you are able to perform, or to exaggerate the abilities of any piece of machinery, just for the sake of making a sale.

"I feel that I am well within the truth in stating that our business during 1919 has been nine-tenths cash," continued Mr. Hartman. "Just think of all the bookkeeping this alone saves! I always try to show the customer where it will pay him to go to the bank and borrow the money, rather than sign even a short-term note for half or two-thirds of the purchase price."

There is no "live" bank manager who will not lend a competent farmer money to purchase an implement which will help him increase his production. This has been found particularly true where farmers are contemplating buying tractors. A bank manager will at once recognize how much this will mean in increased production. He usually is only too willing to finance the transaction—or at least a portion of it.

## Put Yourself in Your Prospect's Place

INTEREST yourself in your customer's business and get him interested in yours.

This is the secret of successful business, says W. J. Clark, implement dealer, of Aikona, Ontario, in discussing with the M.T.I. some of the points which lead to profit, as well as to the maintaining of a high standard of business integrity. Mr. Clark was asked to itemize the fundamentals which have been responsible for his business growing to its present proportions, and after innate feelings of modesty had been overcome he listed some "pointers" as follows:—

"1.—An implement dealer must have confidence in the goods that he is offering for sale, otherwise prospective buyers will, in some way or another, become unfavorably impressed. I firmly believe the lines I handle are the best on the market to-day—away ahead of any other competing goods. I believe in selling the class of goods that I would buy and use myself. I suppose this is really an application of the Golden Rule: Put yourself in your prospect's place.

"2.—I endeavor to give service—promptly and efficiently—to any person who buys from me; accordingly, customers learn by experience that they will not be left tied up, or in the lurch, at any time.

"3.—I study my lines of machines every minute, and also study the other fellow's. I am thus in a position to point out to all prospects where my lines have it over the lines handled by my competitors.

"4.—I always try to appear cheerful and bright, even though I have my own troubles the same as anyone else; thus I endeavor to put good humor into my prospects.

"5.—I try, if possible, to arrange my calls so that I can visit a prospect under the most favorable conditions. I don't talk to him if he is too busy, and if he is perturbed by some difficulty I try to give him a hand to help him out. Then I leave him without taking up his time to discuss the implement I am trying to sell him, and make a point to drop around some day soon afterwards, when he is likely to be in a happy mood.

"6.—I do not like pessimists—nor do I like to be a pessimist myself. This world would be a better world if there were more optimists in it, and there would be more successful implement dealers if they were more optimistic as a class. If a prospective customer is feeling blue and gloomy, I tell him things are bound to change for the better; and try to convince him that implement prices and agricultural prospects are sure to improve.

"7.—I try to be generous in small things; this helps to turn small deals into larger deals.

"8.—I endeavor to be kindly disposed to all men. I laugh with those who are merry, and weep with those who are sad. I tell a story to those who like stories, and try to cheer up the sad ones. I study each customer so that I will be familiar with his every mood and quirk.

"9.—I get my prospects interested in my business, just as intensively as I am interested in theirs. I ask each man the names of persons in his community who wants a binder, or a mower, or a tractor, and he feels that he is helping me to sell a machine. I find it is a greater incentive for him to buy when he feels that he is co-operating with me and helping me sell.

"10.—I try to be lenient where the occasion demands it, and I endeavor always to keep my word to the letter. An implement dealer may find he occasionally suffers a temporary loss by sticking to this policy, but it will be a gain in the long run."

## Service, Clean Business and Frankness

"SERVICE and clean business"—this is the motto which has enabled Charles I. Edwards, of Rocky Mountain House, Alberta, to put across a record business for 1919, and start 1920 with the brightest prospects of any implement dealer in his section of the province.

A policy of absolute frankness has also combined to build up Mr. Edwards' business. Discussing this phase of implement dealing with the M.T.I. he says:

"When a prospect comes into my place and wants a piece of machinery, I always endeavor to find out exactly what he wants it for. If, after discussing the question with him, I come to the conclusion that he does not need this piece of machinery—or, at any rate, does not need it now—I tell him so, frankly.

"If I have a line which is more suitable, I show him this, and let him decide between the two. It is poor business to sell a man an article which is useless to him—or even one where he won't get as much value from it as he should. It is far better to let that sale pass; in this way you will keep him as your friend, and you will do business with him later.

"Cash sales are better for the implement dealer as well as decidedly better for the customer.

"Last month a farmer wanted to buy an Oliver gang plow, a third cash, the balance in a little more than two months. I pointed out the difference between the cash price and time price, and then drew his attention to the fact that interest at 8 per cent. started from the date on the note. I figured it out for him and showed him that the short convenience was not worth what he would have to pay for it. He took the plow for spot cash. He is now satisfied, and has no worry over a note coming due. I also am satisfied.

"Service is one thing that I always make a strong feature of in my business.

"The mail service here is tri-weekly, so in the rush seasons if a man comes along for a part which I don't have in stock, I wire for it.

"I am firmly of the opinion that the man in the garage or implement business, who makes a specialty of giving the very best service is the man who is going to get ahead. I know of a case where a farmer called his neighbor on the 'phone, and said: 'Say, George, I've broken a ring on my engine; who's the best man to call up to get it?'

"I would call up Edwards; he keeps a good stock of parts and repairs on hand, and if he doesn't happen to have a ring in stock he will sure do his best to get it for you in a hurry.'

"My experience has firmly convinced me that farmers' talk and rapid, up-to-date service will keep your place of business humming."



George Hartman, Napanee, Ont.



# CANADIAN MOTOR, TRACTOR AND IMPLEMENT TRADE JOURNAL

Published on the fifth of each month by

The MacLean Publishing Co., Limited  
TORONTO, MONTREAL, WINNIPEG

JOHN BAYNE MACLEAN,  
President.

H. T. HUNTER,  
Vice-President.

H. V. TYRRELL, General Manager.

LONDON, ENG., THE MACLEAN COMPANY, OF GREAT  
BRITAIN, LTD., 88 FLEET STREET, E.C.

BRANCH OFFICES: Montreal, Southam Building, 128 Bleury  
Street; Winnipeg, 1103 Union Trust Building; Vancouver,  
39 Tenth Ave. West; New York, Room 620, 111 Broadway;  
Chicago, 1401 Lytton Bldg.; Boston, 734 Old South Building.

SUBSCRIPTION PRICE—\$1.00 A YEAR.

OFFICE OF PUBLICATION—143-153 University Ave., Toronto.

Vol. II. TORONTO, JAN. 5, 1920. No. 1

## INCREASED DISCOUNTS

**I**MPLEMENT dealers, both in Canada and in the United States, have been agitating for larger discounts, and the agitation has attracted a great deal of attention, from manufacturers and distributors both. M. T. I. is strong for increases, and sizable ones, and for months has been campaigning toward this end. Several letters have reached this office, indicating that this series of articles on "Implement Dealers' Problems" has been followed with great interest.

One of the most successful dealers in the Canadian West writes M. T. I. as follows:

"There is no doubt but that the manufacturers are following you closely, and I should like to see you cover the ground so thoroughly, and place the whole case before them so clearly, that they would be forced to act."

An Ontario dealer, who is struggling to build a small business into a big one, writes:

"Keep up the good fight; I am having a tough time of it making both ends meet, but I won't have to quit here if discounts are raised. More power to your elbow!"

There will be no let-up in our attitude on this subject. At times throughout the year there will be further articles, giving facts and figures which will prove irrevocably the implement dealers' right to larger margins—and a living profit.

Apropos of this, it is interesting to note that one of the largest plow and tillage implement concerns is now billing repairs to dealers at a 35 per cent. below list price. This discount applies to most of the items on the implement list—the exceptions are ploughshares, mouldboards and landsides, on which a discount of 25 per cent. is allowed.

## PEN FOR PAN MAN

**A** WARNING to all automotive Wallingfords who pass the border line of legitimate stock promotion, and thus get within the law's clutches, may be seen in the stiff sentence handed out just recently to Samuel C. Pandolfo—and none too stiff, either, under the circumstances. Pandolfo, who sold several million dollars' worth of stock in the Pan Motors Co., St. Cloud, Minn., got ten years and a fine of \$4,000, on the charge of using the mails to defraud.

Charter members of the M. T. I. subscribers may remember that last spring we ran a couple of photographs showing the Pan car. At that time it was mentioned that Pandolfo was under indictment, and our readers were allowed to draw their own conclusions. Twelve directors, also under indictment, were acquitted.

The verdict finds Pandolfo alone is guilty morally of making misrepresentations to some 60,000 stockholders who up to the present time have paid for some \$7,000,000 worth of Pan Motors Co.'s stock. The stock is \$5 par and was sold for \$10. Pandolfo explained that the additional \$5 was to be used for developing the company. He took as his share that part of the extra \$5 left after paying promotion and development expenses.

## MILKING MECHANICALLY

**T**HE man who first got the idea of milking old "co-bossy" by machinery was a daring inventor, says an exchange. No doubt he encountered the gratuitous advice right and left that this was a function which could not be performed mechanically; that it took the living flesh and blood of a man's hand

## CECIL DIXON JOINS M.T.I.

**C**ECIL DIXON, until the end of 1919 manager of the auto accessories and bicycle department of Hyslop Bros., and one of the best-known men in Canada in his field, has joined the staff of M.T.I.

This is in line with strengthening the publication which, although not yet a year old, has made record progress and already has 3,000 subscribers.

Mr. Dixon will contribute occasional articles and his services will be available to any M.T.I. subscribers who wish to consult him on automotive accessory topics. If there's anything you want to know, write the Editor of M.T.I. and the query will be turned over to Mr. Dixon. He's at your service.

or a calf's mouth. Yet to-day we have a number of mechanical milkers on the market that milk cows.

There is a great and undeniable demand for the milking machine. Properly operated, it solves the acute problem of dairy labor. No dealer can afford to give it any but his most earnest consideration. The future of the milker business is going to be much greater than its past.

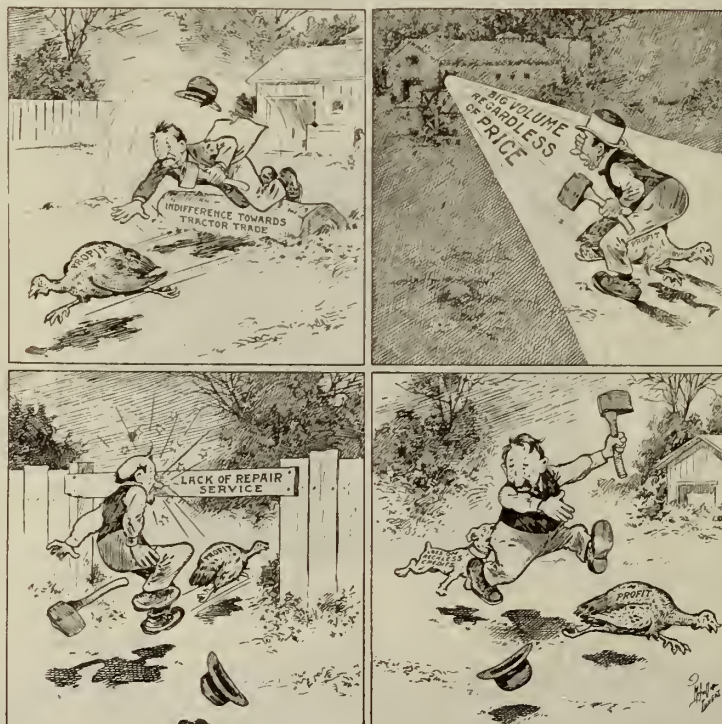

—“Farm Implement News.”  
Some ways that profit may escape.

## SALESMEN—KNOW THY STOCK

**H**OW often has it happened that you have told an inquiring customer you haven't a certain device in stock, only to find out sometime afterward that you had it after all in some unsuspected place? It is safe to say that this happens occasionally in the best of stores. The loss of the immediate sale is something to ponder over, but the effects are much worse if the customer finds later on that perhaps a friend of his went into your store the very next day and bought the same article the first man inquired for.

Every salesman should be kept posted all the time as to just what material is in stock. If the store is too large or the stock too varied for a salesman to

remember every item, the stock should be systematically arranged and carefully indexed so that any salesman in the store can locate any article a customer asks for.

Illustrated catalogues are useful, and well-arranged show cases or sample boards are even better, in enabling customers to pick out articles that they may want. Moreover, a customer looking through a catalogue or on a sample board for some article he has in mind will frequently run across something else that he did not know you had in stock.

The point to remember is that every salesman must know the stock thoroughly, otherwise he cannot hope to realize all the sales possibilities that come his way.—Auto Trade Journal.

## MUST HANDLE TRACTORS

**A**N encouraging sign of the times is the mental attitude of the implement dealer toward the proposition of power farming equipment merchandising. There was a time, not more than a year or two ago, when implement dealers really considered whether they should handle tractors or not. Last year the National Federation at its annual meeting adopted resolutions expressing a belief that the sale of tractors belongs by right to the implement trade. This year at implement dealer conventions discussions are not as to whether they should handle tractors or not, but how best to readjust their business along power farming lines. The thought is being generally expressed that unless the implement dealer does handle tractors, he won't be an implement dealer very long.—Exchange.

## DEALER'S SOUND ADVICE

**T**HAT every member of the automotive industries should be a booster for improved highways is the contention of an automobile dealer who is a leader in Ottawa trade circles. He offers the suggestion that every newspaper advertisement and printed circular used by an automobile house should carry a slogan which refers to the subject of good roads. This man is Fred L. Murphy. Murphy practises what he preaches because his recent newspaper advertising has had the following line:—"Build now the county and provincial roads we need and prosperly will ride to every Canadian's gate."

He has suggested that the Automotive Trade Association of Ottawa adopt such a slogan for general use.

## PREVENTING "LOST SALES"

**A**SUCCESSFUL accessory dealer has adopted a plan whereby he can determine what line of accessories he should stock. He has a printed "Lost Sale" slip, and whenever he has a call for any article he does not carry in stock he requires that the salesman fill out one of these slips, entering the name of the article, the possible amount of the sale, the reason the sale was lost, name and address of party calling for the article and also whether the party wishes to be notified when the store has that particular item in stock. These slips furnish him with a complete history of lost sales and through them he is able to know the number of sales lost on any one item. They not only post him upon articles for which there is a demand that he does not carry in stock, but they also show him the number of sales he closes because of insufficient stock.

For instance, he had never carried a stock of wheel lugs. He merely had a sample of the various designs, and when a customer called for wheel lugs he would show him the samples and order them for the customer. This caused several days' delay, often for weeks. After installing this "Lost Sale" slip, he found that he was losing a large number of sales on these articles simply because he did not carry them in stock. During one week he lost sales amounting to more than \$14 on this one item. It did not take long to place an order for wheel lugs, and thereafter he had them in stock.

Trouble lamps proved another item upon which he found he was losing a large number of sales because he did not have these in stock.



# ROSENHEIM BUYS A FARM

Pinched (With Permission) From "Timken Magazine." Sketches by CLYDE E. DARR



"I contract with a feller to take the extry aigs"

Emporium, high-grade men's and boys' clothing, as he placed a paper bag on the table, the knotty projections proclaiming its contents.

"Sixty cents a dozen did the robbers charge me, without the customary two per cent. off for cash and if I claim a rebate for spoilage a liar I am and nothing I get. A farm I'll buy and be innerpendent."

"Don't get foolish in the head, Max," said Rachel, his wife; "a shoe-maker should stick to his last, remember. You are a business man and can fail any time at a profit, but if as a farmer you fail they take it your farm away and then they laugh in your face."

"Yes a shoemaker should stick to his last and a tailor he should stick by his bench, but the farmer feller he sticks everybody. Sixty cents I pay me now for a dozen aigs laid by a hen what aint worth more as a dollar on the hoof. It don't take any brains to be a farmer. If a farmer was a business man like me he could from a forty acre place be richer than Andy Rockeyfeller. See what he misses by not being a finanseer. A hundred dollars what is invested in them Liberty Buns, works nearly a week to make a nickel, and here one of them dollar hens lays a five cent every day in the week. Each hen represents an earning capacity of seven hundred dollars, and with a hundred hens he could form a company capitalized at fifty thousand dollars and sell stock. Oil wells they go dry and gold wells they play out, but a hen has gotta lay them aigs—they can't help it.

"A great head you got for business, Max, I know, but runnin' a farm aint like a clothing store, and—"

"BUT, nu, I should say it aint, sixty cents they charge me for aigs what I don't see the inside of, which is, perhaps, like a glue factory. When a man buy from me one of them all-wool fifteen-dollar suits he bargains me down to eleven-ninety-eight, which leaves me only seven dollars profit, and I have to throw in a pair of suspenders and keep the suit in repair for a year. Does the farmer feller agree to keep them aigs fresh for even a week?"

"I like it the idee of a farm because of Abie and Rebecca, but, Max, you don't know it even how to milk a cow."



"So easy as sellin' a zoot yes"

"Rachel, how often is it I tell you I got brains? Milkin' a cow is so easy as sellin' a Palm Beach suit to a fat man in July. You just get one of them separators and you just take milk from the cow like water from a faucet."

"Say, Pop," said Abie, who had been an interested listener, "if you go buy a farm you will be called a Rube and a Hayseeder."

"Abie, you get your eidees from them vawdville theatres, where a farmer looks like something left over from a fire sale. Believe me, the Rube is the feller who pays sixty cents a dozen for aigs what is laid by a dollar hen."

"All I can say is, Max, don't let them real estaters cheat you. About a farm nothing you know, remember."

"Rachel, is it you think a man can be cheated buyin' a farm when me they charge five dollars a bushel for pertaters and sixty cents a dozen for sight-unseen aigs? Land is land, aint it? Never you have to allow for shrinkage, styles don't change on you in the middle of the season, and steal it from you nobody can. I go me right now and see about it. If Misses Cohen comes over to borry an aig, remember none you have in the

house. Sixty cents a dozen with no insurance is too big a risk with Misses Cohen's poor memory."

WITH Rosenheim the birth of an idea was a signal for immediate action and soon he was in the office of a real estate dealer who welcomed him effusively. "So, you want to buy a farm? Great idea, Mr. Rosenheim, grand idea. The farmer is certainly a lucky man these days, with wheat at two dollars, butter at fifty cents and—"

"And them aigs at sixty cents for mebbe a short dozen when you count 'em. Nothin' you can tell me about that already. What I want me now is a small farm where I can stick someone else like I get it."

"I have just the place for you. Beautiful little farm of forty acres, well watered—"

"I dunno about that. My dockitor he tells me that them well water is dangerous for them typhoid fever bugs, for me I like the hydrant."

"Oh, well in the country, of course, you will have to put up with minor inconveniences. But think of the fresh air and the pure milk, fried chicken, and fresh

fruit to offset that purely artificial regime that you have lived under so long that you consider it necessary, but which is not. You have a car and can motor to the city every morning in half an hour, and back again in the evening. You can raise everything you eat and have a surplus to sell. All the petty cares and annoyances of city life are forgotten as under your

own vine and fig tree you contemplate life in its wider range, your leisure moments devoted to the study of Nature at first hand, your children joyous and happy, your wife contented and cheerful, greeting you upon your return from business cares with a smile of perfect peace. Such is the home life of the modern gentleman farmer."

"Oi, oi, man, what a clothing salesman you would make! If ever you are out of a job come by the Scotch Woollen Mills and I take you on at your own price. Such langwidge you can use, I like it the way you tell it about that vine and fig tree. Figs they charge me forty cents a pound for, so I guess I raise them myselluf." The deal was quickly consummated after a hurried motor trip to the farm, and Rosenheim lost no time in moving to his country home.

"What you want to do first, Mr. Rosenheim," said the agent after the deed was recorded, "is to get you a good light tractor."

"What it is a tracker?"

"WITH a tractor you can do all your farm work, plowing, cultivating, discing, etc., without employin' a horse at all. I would recommend one driven by a worm. A small one, not the large caterpillar."

"And is it an animal trainer you think I am? Me, I got no time trainin' a worm and I don't think it could be done anyway. Caterpillars there are a lot about the place I know, because Abie put a dozen in Mommer's bed, and a good lickin' he gets, but I think I farm without them."

"You're quite a joker, Rosenheim; but seriously, if you get a small tractor equipped with Timken-Detroit worm gearing and Timken Bearings you'll get good results. Plow deep, cultivate thoroughly, keep out the weeds, be liberal with the fertilizer and you'll win out."

"Rachel," said Rosenheim a few days after they were settled. "This farmin' I think I like. Already I have bargained for a cow. The feller tells me she is dry and he will sell her cheap, so I pay him right away. Water we have a plenty so she will not be dry here. I guess we better speshulize in chickens. I get me one of them inkerbaters and teach you how to wind it up and soon we be getting sixty cents

a dozen for them aigs. I was going to raise pertaters like what we payed five dollars a bushel last winter, but I read in this farm paper, that pertaters is raised in hills, and this farm is as level as a floor."

Rosenheim purchased twelve chickens from a neighbor who guaranteed them to be of a laying stock. Taking them from the car he untied their legs and turned them loose. "A dollar apiece I pay for you and now you lay me them sixty center aigs."

"Max," said Rachel, "is it sure you are now that you will be able to sell all them aigs? Twelve you say we will get every day, which makes seven dozen by the week, with no neighbors to borry, and eat them all we cannot?"

"Ah, Rachel that shows what a business man I am already. An egg peddler I do not wish to be, and the grocery man probably would be a cheater, so when I buy me the chickens I contract with the feller to take the extry eggs. An' honest man he is too"; he says, "Mr. Rosenheim, you aint got the time to sell all them aigs what you are going to get, so I will take them to the market with mine and not charge you a cent c'mishun. He said he would take over ever aig them chickens laid and pay me full price whatever he gets. I like it in the country where the neighbors is so honest and ackomerdatin'."

EARLY in the morning Rosenheim called, "Come on Abie, we go out and pick up the aigs for breakfast—a dozen we should get."

The most painstaking search failed to reveal an egg. "Well maybe they aint got used to the place yet," mused Rosenheim.

"Say, Pop, I didn't know a hen could crow."

"And they can't, Abie, a hen kuckles and a roositer crows."

"Listen Pop, your twelve hens are all crowin'."

Rosenheim's bitterest pill was when Cohen thrust his head into the door of the store and said, "Max, Jakey Steinfelz was tellin' me that you have gone into the 'male order' business."



"Say Pop, I didn't know a hen could crow"



"Sixty cents a dozen did the robbers charge me"



"Great idea, Mr. Rosenheim"

## Auto Production Sets New Record

TOTAL motor vehicle production in 1919, including passenger and commercial, reached 1,891,929, representing a wholesale valuation of \$1,807,594,580, establishing a record in the automobile industry, the National Automobile Chamber of Commerce announces. Passenger car production was slightly less than in 1917, totalling 1,586,787, as against 1,740,792. Truck production, however, advanced from the previous high record of 227,500 in 1918 to 305,142 in 1919. Motor vehicles exported during 1919 aggregated \$110,000,000 in value.

Combined with the wholesale value of bodies and accessories, last year's wholesale valuation places the automobile industry on approximately a two billion dollar basis, with prospects, it was said, that the business during the current year will rank second to steel among the manufacturing industries of the United States.

The largest percentage of increase in registration of cars during the past two years has been in the agricultural districts, Tennessee, Alabama, Louisiana and Georgia leading. New York leads in the actual number of registrations with 570,000 or one for every eighteen persons in the state. Ohio is second with 511,000. Nebraska and Iowa divide honors in leading with the greatest number of cars per capita, statistics indicating one for about six persons.—New York



# Almost Any Garage Can Be Improved—and WITHOUT SPENDING REAL MONEY!

WE have often been told how to improve our places of business, and as a rule the suggestions are good, with this exception, that they call for real money to put them into effect; and who ever heard of a garage man who had any money that he could possibly spare? The "big bugs" in the city might have lots to spend on "trimmings" but we little fellows out in the country are nearly always "shy." So it's no use telling us how nice we could make our place if it means spending some of that money we are always trying to corral, and which keeps us just one jump ahead of the sheriff. However, here are a few ideas that won't cost you anything to speak of, and are absolutely sure "result getters." I know, for I've tried them.

Don't buy anything that you have to educate the public to understand; there are enough lines that they know well to make you a living!

Most places have a showcase of some kind; it should be kept clean inside and out. Don't let the help plant an oil can on it to leave a greasy circle, to which the dust will stick. It is a mistake to pile any old junk inside the case; one of a kind is enough if the case is small, and when you sell that, replace it with a bright new one out of the package. A few attractive showcards will also help to sell different lines. I make it a rule to stock nothing until the public begins to ask for it. When a traveler tries to sell me something and tells me what a wonderful thing it is I put the issue squarely up to him and say, "When you have created a demand for the article and have the public asking for it, then I will stock it." I stand a chance to lose one or two sales at the start by not having it on hand, but I do not stand the risk of having a lot of money tied up in dead stock.

EVERYBODY has heard that "first impressions are the most lasting." This being so why not make the first impression anyone gets of your place a pleasant one? By keeping the entrance spick and span, you will go a long way to accomplish this. Of course the back should be just as clean, but, *Keep the Front Clean.* Give the gasoline pump a coat of nice red paint each spring, and wipe down the lubricating oil tank. Have a rod handy to test gasoline in tanks and to turn on the oil level cocks of Fords without crawling underneath.

If you do storage business, or have occasion to drive other people's cars, either to test them or move them around the place, have a clean dust coat and cotton mitts to put on. This will prevent your overalls, or the overalls of your men from soiling the trimmings of any car, or leaving grease spots that are likely to come off on the good clothes of your customer. What is more annoying to a lady entering her car than to have a nice dress soiled, or a pair of white gloves marked by taking hold of a steering wheel recently held by a pair of grimy hands.

I know you can't keep your hands clean in the garage business, but you can have a pair of cotton washable mitts to avoid handing on this grease to people who want to be your customers. You will probably find an old dust coat and mitts—that only require the attention of the "Chink" to put them into your service—are a pair of business-getters.

When a man rents space in your garage *keep it for him.* Don't plank other cars in his stand, even if he is out. He rents it for 24 hours a day and is entitled to it. Of course if he is away on a vacation or you know definitely that he will not be in for a certain length of time it would be all right to use his space if you are pushed for room, but not otherwise.

YOU will probably have a certain number of cars laid up for the winter. Make a point of having the customer take out all his tools and loose equipment and leave them at home; if he doesn't do this, take them out yourself, tag them and put them away in a safe place. Nothing is so annoying or does more harm to a place than to have stuff lost off cars while in your care, and it is practically impossible to be watching them all the time. Should you even replace a lost article it is never the same as not losing it at all, and the customer is apt to think that there is the chance of losing tools if the car is left with you. Get

the reputation of not having stuff lost on your premises.

Lime wash the place inside every two years or so; you will have to spend a little cash but you can surely "spring" enough to do it when you consider the difference in the appearance of the place. As a matter of fact the saving you will make on electric light bill will soon pay for any outlay in decorating.

Put water in every customer's radiator without waiting for him to ask for it, he is pretty nearly certain to need it. While you are doing this, ask him if he has put lubricant in his axle or transmission lately. You will sell quite a bit more grease and heavy oil if you do this and there is good money in these sales. Such parts are out of sight and consequently often out of mind; the customer will appreciate your mentioning it. Don't forget to shoot a little oil over the spring shackles and leaves, it will help out on the squeaks and cost you nothing. You can keep an old paint brush for this purpose, and the oil you drain out of engines can be used economically. The action of the spring leaves while running will draw it in and eliminate a lot of "rough riding."

WHEN a man is paying you for something he has done, don't forget to ask if there is "anything else." This will bring to his mind in many cases some little thing he needs and you will be surprised how often you can "keep the change."

The small sales help out the year's total and most of them give you a nice margin of profit and after all that is what we want.

## Unsympathetic—But—



—From "Motor World."

Then on the question of stock, don't get loaded up with a whole lot of any one article. Travelers will spin that old, old yarn of the desperate shortage there is going to be; but never mind, spread your money over more than one size of tire or spring; keep, say, two of each of the smaller sizes, except the 30 x 3½, which is the fast seller. You can put a few more into stock without any risk—but only one of a size when you get amongst the big fellows—and replace them as they are sold. It will cost you a little more express; but the extra discount you can get by paying cash when due will easily cover this; and besides, your standing with the manufacturers will be much higher than if you are unable to meet drafts when due. The manufacturers would sooner see you do a sound business and "clean up" every fall than have a lot of dead stock that you want to hand back to them instead of paying that overdue account.

Get a good slogan for your business and include it in all your advertising and on all your stationery; print it on your road signs if you have any out, and if you haven't for goodness sake get some out, they are real business-getters.

These are a few tried and tested plans, and if you can show me where any of them are going to cost you much real money I would like to hear of it. They will put money in your pocket and raise your place out of the common rut. When you once get to this stage it will be no trick at all to pay for the extra paint and fittings you have been wanting to put on the place, and it will work just like compound interest. The more you do, the more you will be able to do. Get busy and try out some of these schemes; they cost you nothing and are surely worth trying.

## How NOT to Adjust a Carburetor

By F. H. SWEET

AN OLD warrior writes to ask how to adjust a carburetor. (He's a warrior, because he says he's repaired every Ford in his county, by heck, and any fellow who can battle that many Ford owners is a warrior.)

Adjusting a carburetor is perhaps the most delicate operation that a Ford can be put through. For seventeen long years we adjusted from one to eight carburetors a day—and truly the first hundred are the worst.

This is the way to do it: First, ask the owner a lot of fool questions—this: "Do you have to put much air in your tires?" If he says, "Quite a good deal," look wise and say, "I thought so—too much gas." Then tell him a long story about how much power it takes to run a Ford when you have to put air in the tires quite often. Of course that has nothing to do with the carburetor, but what's the diff. anyway? He's paying money for your advice—so give him a lot.

IF you have on very greasy overalls, get up on the seat. While you are racing the motor, rub as much grease off onto the seat as you can. Rub your greasy hands all over the steering wheel, too. This helps the owner to remember your garage.

Be sure to open the cutout. Race the motor likell. This racing is good for any motor, and besides you never can tell how the mixture is—unless you race it for about ten minutes.

Then after you have decided that the motor will really go—in spite of you—look under the hood. This is to see if the carburetor is still there. Some mechanics go so far as to touch it. We don't recommend this. If the owner insists on looking over your shoulder, turn your head quickly several times and spit tobacco juice in his general direction. About two spits will keep him out of range. Monkey around a little with timer wires and the radiator and fan. Then put on the hood. Tell the owner he's "sittin' pretty now." Charge him two bucks.

The driver will believe you, and away he'll go—hell-bent for election. Don't laugh until you are sure he's around the corner.

## NO U.S. TRACTOR MEET

ONCE again it has been decided by tractor manufacturers in the U. S. that there will be no sanctioned national or regional tractor demonstrations during 1920. This was decided early in December, at the annual meeting in Chicago, of the Tractor and Thresher Department of the National Implement and Vehicle Association. It is not anticipated that this decision will have any effect on demonstrations planned in Canada, although the feeling of the tractor dealers, distributors and manufacturers in every province of the Dominion is setting more and more against "shows" which are really no test at all. There will be dozens of district, or regional, demonstrations in all parts of Canada during 1920, it is confidently anticipated.



By D. R. A. DRUMMOND

—some of the wisdom given to the C.F.M. Co. dealers at their recent convention in Toronto.

IT is misleading to say I am to talk of the American dealer; I will talk of the American and Canadian dealer; I know them both.

I was in the office of the president of one of the large tractor manufacturers, a short time ago, when the representative of a "Farm Paper" came in. You know these men have a bad habit of hunting up the president of a firm first and then asking him embarrassing questions. The first question this man asked was: "What do you know about service?" The president just threw up his hands and cried, "HELP."

I do not think you have had it quite as bad here as in the States. We have misconstrued the word until we hardly know what service is. Service has come to mean a great many people going out and taking care of a man, not charging him anything for it. That is not service.

To give you an illustration of that: I am not altogether an example of what a young man should be. When I was younger I was a lot worse than I am now; my mother died when I was a baby, and I was the only son my father had, and he would give me everything he could; he gave me about half what he was making, and I was living in hopes that I would get three-quarters. They will do it every time and you can ruin a boy at that rate just as fast as you want to, and you can ruin a customer in the same way. Giving a man his repairs free is doing him harm; he comes to the place where he is helpless; he has forgotten how to think. If a man is going to give himself any service, he has to use his brains, and if you don't use your brains, they will go out of business. I don't mean every time you give a man a bolt or a nut you should charge him \$5.00 for it.

I WAS one of the original men in Western Canada; I was born in the Province of Quebec and went west when sixteen years old. I gained the title of "The Tramp Engineer," because I was always on the move. I had just one policy when I was doing repair work, and that was, "When you see a man with \$5.00, if you can get \$4.95, take it; if you come to another man who has only a nickel, let him keep it; he needs it worse than you do." Let the rich man pay for the poor man's repairs. That is one system that fell down; it was all right with us, but you cannot handle it.

The system originally put up by the Canadian Fairbanks-Morse Company and the J. I. Case Company was to put a machine in the field and take care of it for nothing. The only thing they charged a man for was when he broke something; you could make him pay for the parts, but not for putting them on.

That was a fine policy for the farmer. When I started to work for the Case Company, they were doing that. I was called out from Winnipeg to Mackle-rob, on the Saskatchewan line; I had to get off the train at three o'clock in the morning; it was nice and cold, and there was no one to meet me. At last a Ford car came along and took me out nineteen miles. The man said: "I do not know what is the matter with this machine; it never will go." I walked over to the engine, cranked it up and it went, and it is going yet as far as I know.

We changed our system. When a machine goes out of our factory we are confident that it is in good shape. That is the first service we give. The biggest part of our service is making the machine right. We say it will work, if it does not we will stand behind it. When that machine goes out, we send a man out with it, if possible; if it is sold from a dealer to a customer, the dealer takes care of it, but we see that the dealer can handle the machine. Once we get the dealer educated that is done. When he understands that machine then it is up to him to pass his information along. If he sends that engine 25 miles or 2,500 miles, it is up to him to see that the man who gets it, knows what he

# Dealer Service Methods

has got, and the more he tells that man what he has got, the less trouble he will have in service.

THE instruction book is a small thing, but instruction books to-day are almost a text-book. We have two men in our office doing nothing else but writing instruction books. They spend their time hunting up every little detail, and making sure they put into the instruction book what a man needs. One of the dealer's biggest services to his customer is to make him read his instruction book, even if he has to stand over him with a club. There is something in them that the average dealer does not know, because he does not read them up. The time spent with a customer on his instruction book is worth a lot of money.

After you have him started, when you are driving through the country, it won't take you very long to stop off and ask how he is getting on, and see if you can tell him anything that he does not know. If you have made a study of your engine, there is something you can tell them that they would be glad to know. That little piece of service to some dealers means thousands of dollars—just dropping in on your customer a month or six weeks after you sold the machine.

Of course, you have to understand it yourself first. That is rapidly bringing the service line to a matter of education, and this educating of the customer has become so important that the big tractor manufacturers are spending thousands and thousands of dollars in nothing else but straight education.

Last week I sent two men on the service work. I gave them \$350 expense money apiece. One went to San Francisco and the other to St. Louis. Each man carried a trunk that cost \$55; in that trunk he had 360 slides that cost 20 cents apiece; he had a protector and it cost us \$4.80 wholesale; he had two extra lamps and they cost \$7.50 wholesale, and he had a good deal more equipment. Last summer we had three men working on school equipment, and they were getting pretty good pay; we have 15 of these outfits this year. Next year we will have to have 50.

WE are going to hold about 200 service schools in the United States and Canada. That gives you

want to put their hands up, so I asked those who did not know the difference in the principle of the two, and nearly every hand in the room went up.

THERE is information dug up by the Agricultural Colleges, by the Experimental Farms, at an enormous cost which does not get to the men it should reach. I believe in Canada it gets to the farmer better than any place else in the world. I know that is the case in Western Canada. The Western Canada farmer is a great reader and he gathers up a lot of this information. Where he does not do it, it is a good idea for the dealer to see he gets the books, and persuade him into reading them.

I walked into a dealer's place in the West; he had done a big business this year. I said, "Where did you get it?" He said, "You see that bulletin board; there is not a bulletin published at the Agricultural College that is not put up there." He said, "I take every farm paper and dealers' paper I can get, and any useful information I get goes on that board. I never used to have a farmer come in here unless he wanted to keep the stove warm, but now they stand up and read everything on that board. I do not believe there are 4 per cent. of the farmers in this district who do not read that board every Saturday. When they find out how to use my tractors, they will buy my tractor." Every dealer has a little proposition of his own.

I ASKED one dealer what he did about service; he said: "I found that the first man I had to give service to was myself. I could not have these men abuse me and have me tearing all over the country doing their work for nothing." If you don't give free service, the farmers will kick for a while, but they will soon wake up to the fact that you cannot give them that. If you give that service free of charge, you have to figure what your service has been on a certain number of tractors, and add to every tractor just about that much to allow for service. That means that every man who does not call on you for service is paying for the man who does, and out of deference to your good customers you cannot do that.



Here is an interesting stunt, in which a dealer got lots of advertising for Fisk tubes. A vaudevilleian with strong teeth pulled the Studebaker through the streets of a large city. Some tow-line!

an idea of what value the manufacturer places on education. It is merely a matter of getting a man acquainted with his machinery so that he knows what he has got. For a man to give that, you have to have the confidence of the man you are talking to, and the way to get confidence is to know the thing yourself before you try to teach it to someone else. To learn this thing yourself is a simple matter; you can get all the help you want from the J. I. Case Company and from Fairbanks-Morse.

Put yourself in the position where you can handle this stuff, and don't stop there; that is where a great many men make their mistake. They think as soon as they know the mechanical part of a tractor they have gone as far as they need to go, but that is just the beginning. You would be surprised how few people know what they can do with a tractor. You would be surprised how few people know the difference between tractor power and horse power, and there are still people who don't know the difference between tractor and horse implements.

A man to be a successful dealer has got to study. In one school last winter, just for fun, I asked every man who knew the difference between a tractor plough and horse plough to hold up his hand, and there were two hands up. I thought it was because they did not

charge on each car, followed by a refund when the dealer reports the sale of the car, together with the name and occupation of the purchaser. This plan has proved of value not only to the company, but also to the purchasers in tracing stolen cars.

Up to the present, this second benefit has been more clearly demonstrated in the States than in Canada, although it has also proved its usefulness in a number of cases recently in Western Canada.

Under the system a certificate is attached to each car sent out from the factory, calling for a refund of \$5, which the distributor is compelled to pay to the factory. The distributor collects from the dealer and the dealer in turn, in order to get his \$5, returns the certificate to the factory, with the name, address and occupation of the purchaser thereon and the factory refunds his money.

The certificate bears on its face the serial number of the car, the engine number of course being on record at the factory. Shifting an engine thus is of little benefit to the thief for a wire to the factory, in case of suspicion that a car may have been stolen, brings the name of the purchaser, the number of the car and the number of the engine which should be in that particular car. Inquiry of the purchaser enables officers to determine whether it has been stolen.

## One Way to Check Thefts

WILLYS-OVERLAND, Limited, of Canada, has followed the plan, also in use in the American company, of making a \$5 sur-



Buys Car and Pays For It With Nuggets

# 23,700 CITY has \$50,000 GARAGE

“ONE of the finest and most modern of garages,” is the claim made by Angrove Bros., concerning their garage on the corner of Bagot and Queen Streets, Kingston, Ontario. After making a tour through the garage, the M. T. I. representative avers that in no Canadian city of 20,000 is there a larger or more up-to-date one.

H. and T. Angrove have been connected with the automobile business in Kingston for about twelve years. They were the pioneers in Kingston in the then new industry, having bought and sold the first car in their district. In 1907, they were engaged in selling sporting goods, bicycles, sewing machines, etc.

When a representative of the Ford Motor Car Co., in 1907, came to Kingston to establish an agency, he was directed to the Angrove brothers, by prominent citizens, as being the most likely men. The result of the interview was, that Angrove Bros. started in on a new and comparatively unknown field, and Kingston had its introduction to the latest means of locomotion.

For the first season, Harry Angrove, the younger of the two brothers, went around the district soliciting orders. Then they bought one car and commenced a series of demonstrations which amounted to numerous joy rides—but business was rather slow. However, after some strenuous work, they managed to sell their first car, but at a loss of \$300. After this first sale was made they started slowly to sell a few.

The next season there was a marked improvement, as they succeeded in selling about thirty cars; very good business indeed, when one considers that the public was still skeptical, and that bankers regarded the car as a dangerous business and purely a luxury.

THE Angrove brothers now considered, if they wanted to succeed in their new line, that they had to break away from their sporting line and open up a garage, where they would be in a position to handle their now rapidly-growing trade, and be able to give the proper service to their customers. They therefore fitted up a small garage and directed all their energies to expanding their business.

From early morning until late at night they made a personal canvass, not only of Kingston, but also the whole county of Frontenac. They circularized by letter and post card. On the post cards were printed statements and short striking notes regarding the utility of the car. They found this system very productive and kept it up for several years.

Four years ago, they again found it necessary to seek larger quarters, and as the Salvation Army building was for sale, they purchased that, and had it transformed into an up-to-date garage and show-room. It is situated at the corner of Bagot and Queen streets, and has a frontage on Bagot street of 130 feet. The location is an excellent one, being right in the heart of the city and very convenient for motorists.

The garage consists of a ground floor and two upper stories. A two-car capacity elevator connects the ground floor with the upper stories. The entire building is constructed of brick and reinforced concrete, and is absolutely fireproof.

The lighting system is worthy of special mention: large windows, extending from the ground to the top storey, give so much light that comparatively little artificial light is required in the day time.

THE show room and garage proper are on the ground floor. They are equipped with every modern improvement. The appointments of the office, adjoining the show room, are par-

## Kingston Garage Has Windows Two Storeys High



In the early years of the century, Angrove Bros. ran a bicycle and sporting goods store. They graduated into the auto business in 1907. Harry Angrove can be seen at the left, John in the center.

ticularly fine; a multigrapher is one of the features.

The workroom on the first floor is 90 x 53 feet and has a capacity of 25 cars, on a working basis, with lots of room.

raise 140 pounds pressure in about five minutes. In mid-summer, when the season is in full swing, about twenty-five men are employed in the repair department. The services of about fourteen are retained during the winter months.



Exterior of Angrove Bros.' "Salvation Army" Garage, Kingston.

One of the most important features of the workroom is the oxy-acetylene welding department. This department is claimed by the proprietors to be the equal to any garage welding department. They can

“In this business one has a good opportunity to observe and study human nature. By studying the people we come in contact with from day to day in the pursuit of our business, and trying to sense their needs, in a large measure, is the reason of whatever success we have achieved.

“It is our motto to deal honestly; give good service; and favor none.



Harry Angrove, at the helm of the first Ford in Kingston, more than a dozen years ago.

do any kind of welding, cast-iron and aluminum included.

“We attend to all wiring troubles,” said J. Angrove. “In fact we do all repairs required on a car from start to finish.”

In their storage battery department, Angrove Bros. have a Stahl Rectifier, capable of charging 30 batteries at one time; and a storing rack with a 200-battery capacity. They make a specialty of battery work and find it is a growing branch of their business. Motorists are more and more taking advantage of the spacious racks, for storing their batteries, where they can be properly attended to.

The garage boasts a fine paint shop, and an expert is kept who is capable of doing the finest work. When the M. T. I. representative was being shown through the garage there were two cars in the paint shop receiving their final coat of varnish, after having been built up from the foundation.

In the stock room they carry about \$25,000 worth of accessories and tires. The machinery, in the machine shop, and the vulcanizing department, is operated by a 4½-horse-power motor. This motor also provides the power for driving the air compressor. Motorists don't require to wait for air at Angrove's, as their compressor can

AS can readily be imagined, this garage came into being through hard work, and the exercise of fine business acumen. All departments are systematized and put on their own feet. Books are kept in each department, and when an operation is completed, it is recorded in detail in the department book, and an itemized charge-slip is then made out and sent to the office, to be entered up in the ledger.

“Only in this way,” says J. Angrove, “can we keep proper track of our various departments; and at a glance can tell whether or not the different departments are paying.”

“It is a wonderful business,” said Mr. Angrove, speaking of his experience in selling cars. “Though we have had to work hard, and—in the early days especially—progress seemed to be slow, we have enjoyed it immensely, and have had many interesting and varied experiences.”

“In this business one has a good opportunity to observe and study human nature. By studying the people we come in contact with from day to day in the pursuit of our business, and trying to sense their needs, in a large measure, is the reason of whatever success we have achieved.

“It is our motto to deal honestly; give good service; and favor none.

“WE make it a rule never to sell a car to a prospect unless we know he can afford to buy. During the war we refused to sell on many occasions, because we considered the parties concerned were not in a position, financially, to purchase and keep up a car. Some may think this bad business, but we have found it necessary, in the interests of our customers, and in our own interests, to adopt such a strict measure. By selling to parties who can ill afford the purchase of a car, it only leads us into trouble.

“During the war, a woman bought a car from us; at the time of purchasing, she paid half the price, agreeing to pay the other half by short note payments. When she had finished paying for the car we learned that she had two sons overseas and had been using their assigned pay



to meet the payments. If we had known that at the time, we should have refused to sell to her, considering that the money was required for other purposes.

“AS I said before, we have had many curious experiences in selling cars. A man blew in one day, curiously attired. He was dressed partly in a miner’s outfit, and partly in ordinary civilian garb. He wanted to buy a car, and asked for a demonstration. After fully demonstrating the car, and quoting him the prices, he decided there and then to purchase. The bill was made out and handed to him. He glanced at it a moment, then stooping down and fumbling inside his leather leggings, pulled out a packet of gold nuggets and tendered them in payment. Needless to say we were very much surprised; but the gold was good, we liked the look of our miner, and the bank valued the nuggets for us. Thus we registered our most unique sale.

“In accordance with our motto—to give good service at all times—when taking on a new man in any of our departments, we always impress on him the importance of real service. We say to him, something like this:

“YOU are employed here at so much per week; now, don’t forget that your first duty is to look after our customers’ interests; in everything you do, see that it is done as well as it is in your power to



This picture shows Angrove Bros.’ workroom and repair shop to-day. The workmen can repair twenty-five cars at once here, and many more can be packed in if necessary.

do it; and don’t overcharge: if you do this, you will be looking, not only after the customer’s interests, but after your own and ours as well.

“Some of our best customers—who use our garage all the time—like us to look over their cars from time to time, and do whatever repairs are necessary, without their having to tell us.

“A short time ago, I filled a customer’s radiator with anti-freeze—sufficient to protect him in any weather all season—without his knowing it. A few

days afterwards he came in and had some little thing done to his car; and as the weather was rather cold, he thought it a good time to put in some anti-freeze. So this man—not knowing I had already filled the radiator, and as I was away at the time—ran off the anti-freeze, thinking he was running off water, and filled up the radiator again. Of course, that was a dead loss to us as we had to make it good. We considered it better to pay eight dollars for anti-freeze than to offend a good customer.

“WE believe in advertising, and doing it extensively. In the local daily papers we run ads. from one to three times a week; seldom inserting the same one twice. We also distribute circular letters profusely among our prospects. A prospect file, giving all details, is kept and is practically indispensable.

“To take care of our business in the outlying parts of our district, we have found it necessary to employ sub-agents at four different points. In this way we can thoroughly dragnet the country, and keep track of its pulse, so to speak.”

For years, after Angrove Bros. entered the automobile business, they handled Ford cars exclusively; then they took on the agency for the Chevrolet and McLaughlin cars. They now specialize in the sale of McLaughlins.

## Westlock’s “Service Garage”

WESTLOCK, ALTA.—So rapid has been the extension of automobile traffic in this section of the Province that the Service Garage, Ltd., which now has accommodation for forty cars, is being enlarged so that it will hold twice the number.

“See us for correct lubrication of your motor and tractor,” is the huge sign that makes a very effective greeting as you approach the Service Garage. This was formerly known as the Wheatley Garage, but has recently been taken over by Alfred D. Jorgensen, who came to Canada a short time ago from Minnesota. It is a red brick structure, electrically-lighted throughout. Repairing on both tractors and autos is being made a specialty. When the addition is completed there will be nothing superior anywhere in this section of the Province.

One of the leading implement and tractor dealers in the vicinity is Albert Montpelier, who was originally in the blacksmith business. He specializes in welding.

W. R. Tennant and Sons—Leslie and Alex.—have seen their Ford agency business grow so rapidly that it has been found necessary to put up a new building. At present they are in temporary quarters in First Street, but in the spring they will move into a fine

new brick structure, a garage and show-room, 45 by 60, and modern in all respects.

O. B. Prosser, whose garage burned down in September, causing a very considerable loss, is already

### IT’S ALDERMAN CLOW, NOW

*Fred. M. Clow, Kingston’s live implement dealer, jumped into the municipal contest January 1, and emerged as alderman. If he makes good in the civic arena as fast as he has done in the implement business he’ll be Mayor soon. M.T.I. has sent a staff writer to see Mr.—beg pardon, Alderman—Clow, and this article will be one of the features of next month’s issue.*

in business again, handling his work as if nothing untoward had happened. Prosser’s was the first implement agency in Westlock, and he claims other

“first” records: The first Ford agency in the district; the first Bowser service pump; the first electric-lighted garage. He is located in First Street, and owns the first theatre erected in this town.

It is just five years and a little more since Prosser left Muskoka to come West, and yet his turn-over last year was \$50,000, including eleven tractors placed with enterprising power farming converts in the adjacent territory.

### DEMONSTRATION IN QUEBEC

THE next big plowing match and tractor demonstration for Eastern Ontario and Western Quebec will be held in the fall of 1920, at Ste. Anne de Bellevue, Quebec, according to the decision announced after a meeting held December 16, at Montreal, of the Inter-provincial Plowmen’s Association of Eastern Ontario and Western Quebec. John Hay, M. L. A., of Lachute, Quebec, was elected president for the ensuing year, and the secretary will be selected at a later meeting.

### COMING AUTO SHOWS

OTTAWA.—February 21-28. Automobile and Truck Show.

MONTREAL.—January 17-24, auto, truck, tractor, and accessory show, under auspices M.A.T.A.



This is a splendid garage, in Northern Alberta; formerly Wheatley’s Garage, but recently taken over by A. D. Jorgensen.



The General Ordnance Company of Cedar Rapids, Iowa, Derby, Conn., and New York City, has just closed a contract with the Ontario Wind Engine and Pump Co. of Toronto, Canada, whereby the latter Company will become active distributors for the G-O Tractor in Ontario, Quebec and Eastern Canada. The first shipment on the initial contract is now in Canada to supply the demand which this Canadian concern is arousing by an aggressive advertising campaign. It reaches the farmer through its many agents, who will sell the G-O direct.



# The LIVE DEALER is ALWAYS the ADVERTISING DEALER

Experience of M.T.I. Representative, After Talking to Scores of Auto, Implement and Tractor Dealers Throughout Canadian West

**D**URING the past few months the writer has visited scores of implement houses and garages throughout Western Canada, from Winnipeg to the foothills of the Rockies, as a representative of MOTOR, TRACTOR AND IMPLEMENT TRADE JOURNAL. Early in May he embarked on a voyage of discovery the sole object of which was to find and tip off to other dealers methods of business that would make more money for them. With no other object in view he visited the scores of implement men, told them point blank the object of his visit, and tried in the most earnest way possible to draw these men and locate original and live methods of doing business. It may awake some interest, and arouse some dealers to their position to state the bald truth. In fully seventy-five per cent. of these cases the visit was as barren of results as William Hohenzollern's attempts to reach Paris.

Since these Western wanderings were completed a short time since there has been time for reflection and analysis, and an attempt will be made in this article to tell why it is that some implement men are conducting a thriving, successful business while great numbers of others are standing still. There must be clear-cut reasons for this, for barring those districts where crop failure has played havoc with business all of these dealers are more or less on an even footing.

To strike right at the root of the thing the great bulk of implement men seem possessed of the hallucination that to succeed all that is necessary is to establish a warehouse with a dinky little office in one corner of it, put in a nice, comfortable swivel chair and wait for business to come to them. In countless numbers of warehouses visited these men were to be found—waiting. They invariably believed too that business could only be done in certain seasons of the year.

**W**ALK in on one of these dealers and ask him if he employed any special methods of drawing business, and you had him floored at the outset. Many would argue that it did not pay to urge the farmer to buy; that he knew his own business, and that when he wanted any implements he would come in his own good time and buy them. They argued that their game was to wait until they came. They stated that they could not go after business because in their absence a customer might come to the warehouse and they would lose a sale. They could not afford to keep an assistant who would stay in the office, they said. They depended for a living largely on the business done in the spring months of the year.

To one of these dealers the argument was advanced that a wholesale house would soon go broke if it simply waited for business to come to it, but he was right there with the alibi that that was altogether a different case.

Meantime, while these dealers were waiting, what happened? The farmers, flushed with money obtained during a long period of high prices for agricultural products, were looking for places to spend it, for spend it they do in large quantities. Not being constantly invited and urged to replace their old equipment of worn-out implements, or go in for modern methods of farming with tractors, individual threshing machines, gasoline stationary engines, power pumping outfits, lighting systems, or any of the lines that the implement dealer has for sale, he buys more land, takes a trip to California or Ontario, buys his equipment from the mail order houses, lays out money for phonographs, etc., etc. Somebody gets the money, and you can lay a dollar to a doughnut that it is the man who goes after it.

And this suggests that portion of the story which deals with that section of the trade who are out after business and who invariably are getting it.

**T**HE first thing that puts you wise to the live wire dealer is that he is an advertiser. Not only does he advertise his goods in the newspaper, using all those helps provided by the manufacturer such as cuts, and prepared literature of a high class, but he advertises himself. He is usually a man of some personality, self-developed though his pushing proclivi-

ties. He is a good mixer, he cultivates optimism even when business looks blue, he takes a prominent part in church and lodge life, he takes part in the affairs of the town—in brief, he seeks by every means in his power to make friends, but in a country district, friendship is nine-tenths of the battle.

The successful dealer is always an all-season man. He tries to forget that there are any seasons, for he aims to put in so many side lines that there will always be a big demand for some article he carries. He goes by the principle that if you can get people coming to your shop on any pretext, you are establishing custom and building up trade. And so he takes several trade magazines, and is constantly "taking his pen in hand" to enquire about new lines that are being placed on the market, and to seek the agency for them in his town and district. He is not fussy about whether the new line is closely allied with the implement business. The main thing with him is to get the coin, and when he has stocked up on all the lines of implements, tractors and automobiles he can carry consistent with the trade offered and crop conditions, he goes in for gas engines, pumps, lighting systems, auto accessories,

power washing machines, lightning rods, hail insurance, phonographs, ranges, safes, cream separators, bob sleighs, cutters, grain crushers, fanning mills, small threshing machines, windmills, etc., etc. He is a busy man. He looks it, he acts it, and his very activity brings trade.

**O**NE of the primary reasons for the success of this man is that he studies the need of the community. He makes a study of what implements the farmers want to deal with the nature of the soil in that district. He never allows himself to become loaded up with dead stock through negligence in this regard. If he finds that too, that the haying season is coming to a close and he has a stock of mowers and rakes on hand, he sacrifices them to get rid of them rather than carry them over to another year. He believes in making friends by giving an occasional bargain, and that there is money in a quick turnover.

Incidentally, the live wire is careful with his credits. He uses diplomacy. He does not rush to offer goods on fall terms without first attempting to have the farmer secure the money from the bank. He does not hesitate to gauge his man and refuse credit to one who is already overburdened with debt.

The successful implement dealer is usually to be found located in a prominent position where he can display his goods to advantage, for this business is the same as any other in that respect, and goods well displayed bring buyers. Even a side street location can be made more attractive by erecting an elevated platform for the placing of the various lines offered, by the use of a little paint, and by some good painted signs. Coupled with the display of goods a live dealer will have a card file giving the names and addresses of all the farmers within 30 or 40 miles of his town. This he will compile from the tax lists, from the telephone directory, and by gradually building it up. He will not only send farmers his own printed literature, but will co-operate with the various manufacturers in supplying them with lists of names for the mailing of cleverly worded circulars from the head office. He will insist upon this co-operation if it is not voluntarily proffered by the manufacturer, and they will appreciate his enterprise.

**B**EST of all he will find a way of getting out after business personally. In these days of motor cars, it is not a difficult thing for a man to run ten or fifteen miles out into the country now and again in search of business. If it is impossible to leave his wife or son in charge of the shop in his absence, he can run out early in the morning or in the evening to offer his goods to the farmer at his own door. There will be no fear of the farmer taking offence at that. Fact is, on the word of several dealers, he likes it. It flatters him to think he is getting a little attention, and he invariably opens up his heart and talks business, telling of his requirements, his likes and dislikes, and becomes a friend and a prospect.

And at those periods of the year that are generally described by his slacker friends in the trade as "off seasons," it will pay him to get right out after business, and spend one-half of his time on the road.

Apart from everything else, the hustling implement dealer will give generous and unstinting service in the matter of repairs. Through no other agency will he make quicker friends of the farmers. He will be willing to go out at any time of the day or night, for that matter, to render service when it is urgently required in a busy season.

To sum up: the difference between the dead and the live agent is: the latter follows in the lines of all modern business by using every method and every agent in his power to invite and land trade. The very fact that he is a live wire and busy takes him out of himself and makes him more sociable and approachable. His spirit of win is contagious. The fact of the matter is that if a man is going to do business, whether he is an implement agent or a peanut merchant, he must get out and START SOMETHING. Nothing nowadays comes to the man who waits.

## IT PAYS TO ADVERTISE

**N**OT long ago the Avery Tractor Company, Peoria, Ill. (whose product is handled in Canada by the R. A. Lister Co.), began to wonder just how many of their dealers believed in advertising and lived up to this belief to the extent of investing their money in paid space. So they sent out a form letter to 100 retailers, requesting information.

To these hundred letters they received ninety-one replies and the resultant statistics disclosed by an examination of the manufacturers' books were illuminating in the extreme.

Eighty-one of the ninety-one dealers stated that they advertised, more or less regularly, and the total amount of their expenditures for the year was given as \$11,746.76, or approximately \$140 each. As the retailers who believed in advertising sold goods valued at \$848,508.71 during the year, the percentage of advertising expenses to sales was only 1.38 per cent.

The average yearly sales of these eighty-one merchants was a little over \$10,475 each.

The ten dealers who did not advertise—one of them stated in his letter that he "never could see any sense in spending good money to help support a newspaper"—sold only \$8,000 worth of goods during the year, an average of only \$800 each.

In other words the entire ten non-advertisers failed to reach the figure attained by the average business of any one of the eighty-one who believed in the power of the printed word.

And the difference between \$800 and \$10,475 is considerably more than the \$140 which the advertising retailers spent to increase their business every year.—"Retail Public Ledger."



# A Story of Progressive Industrial Service---and its close relation to the Farmers of Canada



One of the Harvester Company's large open pit mines.



The Harvester Company has its own coal mines and coking ovens.



Bird's-eye view of the Harvester Company's ore docks, blast furnaces, and steel mills.



Large saw mill, which has a capacity of fifteen million feet of lumber a year used in International machines.



Hamilton, Ont., works of the International Harvester Company—largest and most modern farm machine factory in the Dominion. Machines go from here to every province in Canada.



International Plow Works at Hamilton, Ont. This immense plant devoted to building high grade plows. Largest output by far of any plow factory in the Dominion.

## International Service Begins with the Raw Material

**T**HE great iron ore mines, coke-coal mines and timber lands, owned and operated by the International Harvester Company, which supply the raw material used in the construction of I.H.C. farm machines and implements, form the solid foundation upon which International service is built.

Without an assured supply of raw material, "service" is nothing more than a meaningless word—empty talk. For service, like a chain, is "no stronger than its weakest link." Raw material purchased from outside sources is a weak link because the supply to the manufacturer is not absolutely assured as the producing company has many clients to look after. In case of curtailed production of raw material the manufacturer who does not control his source of supply is going to suffer: The International Harvester Company controls the majority of its raw material supply used in building machinery for the farmers of Canada. Its service begins here—

## And Harvester Service Never Ends!

**I**NTERNATIONAL service and quality continue all the way through the process of original ore and timber production and reduction to workable raw material—continues through transportation to the Company's steel mills and factories, being shipped by the boats owned or leased by the Harvester Company. It continues through the process of manufacture from the time the raw material is dumped into the factory warehouse until the finished products are loaded into cars for shipment to the farmers of Canada.

The raw material is inspected and tested before it is accepted for manufacture and is inspected and re-inspected all through the process of manufacture. The finished machines also are inspected, tested and re-inspected so that the farmer will be assured of good service from the I.H.C. machines he buys and be protected against defective material or workmanship.

Later, when the finished machines are loaded into the cars, International service and quality are loaded into the cars with them. The agent, when he sells a farmer any of the Full Line of International Harvester machines, sells service along with that machine. The farmer knows when he buys a machine bearing the I.H.C. trade-mark that he can get repairs and expert service for that machine whenever needed. The International Harvester Company of Canada, Limited, has sixteen large branch houses conveniently located in the best agricultural sections of Canada, which supply over 3,500 local agents with repair parts, twine and emergency shipments of machines and implements when the farmer wants something in a hurry.

These facts are full of meaning and opportunity for any International agent and for any man who will sell International machines in the future. Write the nearest branch for any desired information.

## INTERNATIONAL HARVESTER COMPANY OF CANADA LTD.

WESTERN BRANCHES — BRANDON, WINNIPEG, MAN., CALGARY, EDMONTON, LETHBRIDGE, ALTA., ESTEVAN, N. BATTLEFORD, REGINA, SASKATOON, YORKTON, SASK.

EASTERN BRANCHES — HAMILTON, LONDON, OTTAWA, ONT., MONTREAL, QUEBEC, QUE., ST JOHN, N. B.



# Quebec Has a Novel Tractor Plow

At this time, when mechanical power has been so much in the public eye owing to the enquiries made for war, it is but logical, as was the case following the great American Civil War, to find numerous inventions for agriculture following rapidly in succession. Recently a Quebec man, L. A. Desy, a civil and mechanical engineer of Montreal, has designed and even constructed a tractor gang plow of unusual form.

Preliminary trials have been successfully carried out by the machine on a farm close to Montreal, and some conception of the work may be gathered from the illustrations here shown.

One of the outstanding advantages that is incorporated in this power plow is the fact that a plurality of plows can be carried by the tractor, the entire mechanism of the machine being operated by the tractor motor located on the front end of the framework. Another feature of economic interest is the light construction of the various parts, thus assuring high efficiency and low operating costs. Still another factor of interest is the saving of time and labor required to run the plow.

Viewed from the near distance it has the appearance of a queer sort of biplane about to take the air, or a mammoth bird with its wings outspread. On closer observation, however, the idea of a flying machine is readily dispelled, as one can immediately see by the construction that the machine is intended for plowing the ground, and not flying above it. The exact method of operation, at first glance, would be somewhat a puzzle to the uninitiated, but the mechanical mind would at once see and understand the principle upon which it worked.

## A One-man Plant

The arrangement of the plow frame and the operating lever is such that the control of the entire machine can be easily manipulated by one experienced man, although it is intended that the engineer in charge will have the aid of an assistant.

That a better idea of the construction and operation may be had, the following brief description is given. The frame of the machine proper is made of light steel channels and angle irons, and steel castings, the latter being largely made on the box pattern, to give strength with lightness. The line drawings shown herewith are to scale, but accuracy of detail in general assemblies has been dispensed with, the various views being sufficiently clear for descriptive purposes.

In the different views the same parts are indicated by the same reference letters and figures. It will be seen that the power from the engine is transmitted through the drive shaft, and the different gears and clutches, to the various shafts for operating purposes. The main shaft carries the friction discs, and the sliding gears that provide two different speeds for the caterpillar tractors. These gears may also be located in a neutral position so that elevation of the plow frames, or the lateral movement of the plow shears, may be obtained independent of the advance movement of the tractor.

The forward motion of the machine is obtained by engaging the gears keyed to the small countershaft.

Raising or lowering of the plow frames (both of which act in unison), is obtained by the movement of another lever in front of the driver's seat. The outer end of the cable is fastened to the upper end of a triangular frame, one of these being located at either side of the machine. From the outer end of each triangle the plough frame is suspended when raising or lowering it into position, and at such a point that the weight of the frame, plows and supporting links, is practically balanced.

The unique feature of the machine is arrangement of the plow shears. The plough "chain" is driven by means of lugs on the outer periphery of the driving sprockets, these lugs being of the forged variety to guide the chain in its passage round the sprockets. The sprockets on either side are staggered so that interference of the plow shears will not take place.

The entire machine and equipment weighs approximately eight tons, and it is estimated that upwards of ten acres can be plowed in less than ten hours. The test, however, was made on land that had not been plowed in three years, and as this machine is primarily intended for Western farming, where extensive cultivation is continually carried on, the amount of work that may be performed may be materially increased.



## THE PLOW PICTURES

The top picture shows a rear view of the plow with the plow frames elevated to allow the machine to turn for the next trip. The second is a side view. The one opposite is a close up view of the plow showing the details of the frames and furrows. The bottom one shows a rear view of the plow in operation.





# COCKSHUTT

## "Victory" Plow

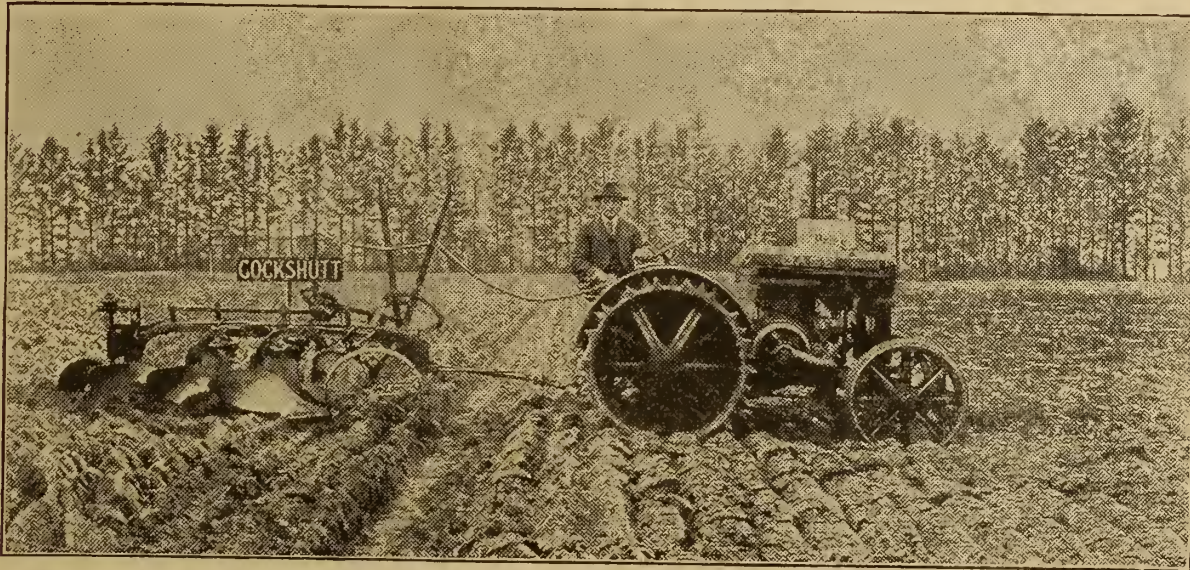

### This splendid Cockshutt Plow won the International Plowing Match at Chatham, Ont.

At the International Plowing Match held recently at Chatham, Ont., Mr. J. B. Cooperthwaite, of Agincourt, Ont., won **FIRST PRIZE** in the Tractor Plowing Competition with his Cockshutt 3-Furrow "VICTORY" Plow. In that contest were 27 Tractor outfits—with 19 of them pulling Cockshutt Plows. Experienced plowmen and tractor operators everywhere realize that for best results with any make of Tractor and under all kinds of plowing conditions, the **COCKSHUTT** is the Plow to use.

#### Cockshutt "VICTORY" PLOW

The Cockshutt "Victory" Plow is built in 2-Furrow and 3-Furrow sizes and with 10-in., 12-in. or 14-in. bottoms.

Automatic Power Lift raises and lowers the bottoms. Operator sits on his Tractor and simply pulls a cord. Extra clearance provided between beams for working dirty land. Every part has surplus strength. Design of moldboards and shares is the result of long experience. They will give YOU the same splendid service they are giving others.

The Cockshutt Agency is a "power lift" that with the proper co-operation from you will make you the busiest and most looked-up to Implement man in your section. Let us send you full particulars.

#### COCKSHUTT PLOW CO., Limited

BRANTFORD, ONTARIO

Winnipeg Regina Calgary Saskatoon Edmonton

*Sold in Eastern Ontario, Quebec and Maritime Provinces by*

#### FROST & WOOD CO., Limited

SMITH'S FALLS, ONTARIO Montreal St. John, N.B.

#### Here is a Business Winner for You Too

A Plow with the proven record of the Cockshutt is bound to be a sales-maker for the dealer who is known to sell it. And we're not content with our victories in the field, but we publish them far and wide and our advertising plans for 1920 are on a bigger scale than ever. There are probably dozens of your customers right now who are thinking about buying a Cockshutt Plow this Spring, so now is the time to get busy.

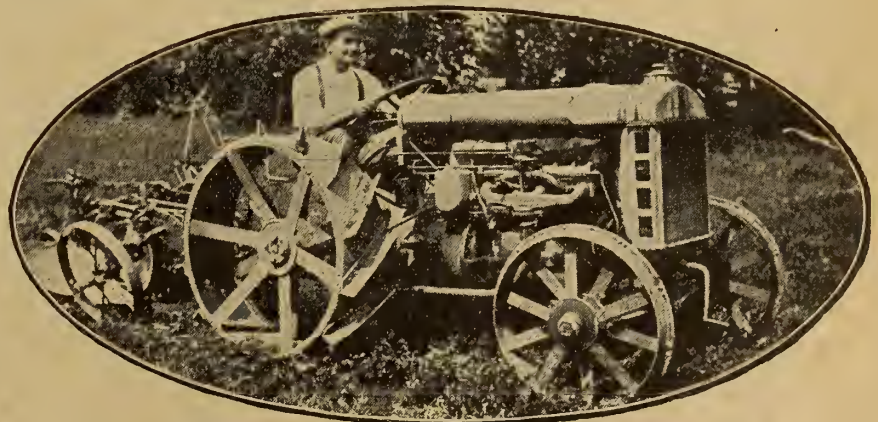

Hon. E. C. Drury, Ontario's Victorious Premier, operates a Cockshutt Victory Plow on his farm at Barrie



# SHOP NOTES FOR THE GARAGE MAN

Rapid Tire Tool—How to Use a Hack Saw—Testing Rod Play

Conducted by SCOTT T. DUTHIE

## HOW TO USE A HACK SAW

A DEAL of skill is required in the use of a hack saw, that is if saw breakage is to be avoided. In the first place the saw requires to be set quite firmly in its frame, given a fair amount of tension, and so held that twisting is prevented. In its use it must be remembered that the teeth are given a certain amount of rake or inclination in order to cut one way only, that is in a forward direction. Therefore, cutting pressure should be applied only on the forward stroke, the saw being eased slightly out of the cut on each return stroke. As a rule, a hack saw frame is so arranged that the saw can be fixed in four positions, this being often a great convenience. Always use the full length of the blade if it is at all possible, the general inclination among workers being to devote all their energies to the middle three or four inches, hence a saw is often scrapped as worn out when only about half its length is unfit for further service. The other half being practically as good as ever. When putting a new saw to work on hard metal, tool steel, or the like, use very little downward pressure, otherwise the danger of ripping off three or four consecutive teeth, and so utterly spoiling the saw, is always present. Use a dry saw for cast iron, brass or gunmetal, but slightly grease it when sawing mild or tool steel. When a saw chokes withdraw it from the cut and rub it downwards with the finger and thumb pressed tightly against the teeth. Present-day hack saws are invariably too hard to be re-sharpened when becoming dull; and it is questionable if it would be a paying policy to do so, were it possible.

## BETTER LUBRICATION FOR VALVE STEMS

T. F. GRAYDON, of Kingston, has revised a simple, but effective, means for lubricating the valve stems on a McLaughlin car, or any car with overhead valves. His idea is to countersink the valve stem guide at the top—as shown in accompanying sketch—so that a pocket will be left to retain the oil, in sufficient quantity to lubricate the valve stem, and in cases where the stem has become sticky from carbon, etc., a little kerosene can be applied to cut the carbon, and allow the valve to move freely.

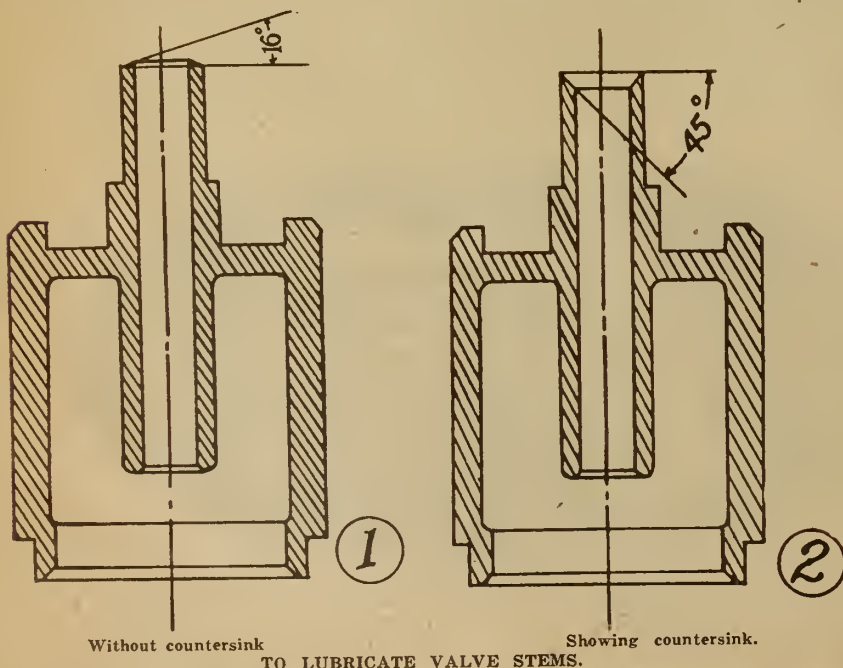

## BUTTER WILL REMOVE TAR

OIL or tar can be easily removed from varnish by laying butter over the spots and allowing it to stand for half an hour or so, when it will soften the material and permit it to be rubbed off easily with a piece of cheesecloth.

## TESTING ROD PLAY

THE connecting rod bearing of an engine can be tested for play by tapping the bearing caps lightly with a hammer. The crank shaft should run snugly, but not too tightly, so that it can be moved backwards and forwards by hand when the compression is relieved by opening the priming cocks.

## OPPORTUNITIES FOR VULCANIZERS IN THE CONSERVATION FIELD

FROM time to time attention has been called to the enormous wastage on automobile tires. In 1918 it was estimated that the loss on tires, that had gone out of service prematurely, was \$75,000,000. It was to stop this waste that The Goodyear Tire & Rubber Company evolved the idea of tire conservation.

Examination of the facts underlying this tire wastage revealed the fact that there were two principal causes—ignorance and neglect. To correct this loss, every possible medium was used to reach the dealer and consumer, to emphasize the necessity for tire conservation.

But there is another factor in conservation—the vulcanizer. Conservation work can be most efficient only when the vulcanizer provides ways and means to get the ultimate mileage out of the tire.

In the small towns where there is no vulcanizer the tire user, who has a damaged tire, has either to scrap it or express it to the nearest town where there is a vulcanizer. The first course involves total loss, while the second wastes time and incurs express charges which are often 50 per cent. of the cost of the repair.

To the young men, particularly the boys coming back from France, the vulcanizer's business offers a particularly attractive field—an opportunity to get into the fast growing rubber business with its unlimited possibilities, for the

vulcanizer's business will grow in the same ratio that cars come into the territory. In 1919 the output of cars is estimated at \$1,500,000.

## RAPID TIRE TOOL

A NEW tool of much interest to garage men, known as the Rapid tire tool, has been invented by a Toronto man, M. P. Wood. It is for putting on and taking off clincher tires. It is made of cast steel and is in two sections. At one end of the longer

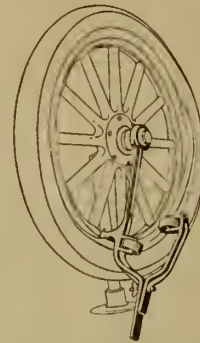

Removing Tire. Rapid Tire Tool.

section there is a ring for fitting over the hub, and midway on the same section there is a hook for inserting under the tire.

To remove the tire, the hook is inserted between the tire and the rim, the ring placed over the hub—allowing the free end to rest on the ground—and by one complete turn of the wheel, the tire is off. In putting the

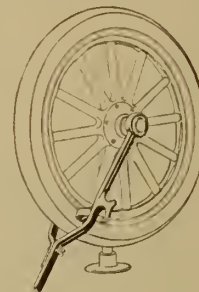

Putting on Tire. Rapid Tire Tool.

tire on, the ring is again placed over the hub, allowing the two small contact wheels, provided for the purpose, to ride on the tires then, by placing the shank on the ground and giving the wheel one turn, the tire goes smoothly into place. There is an adjusting screw on the shank for bringing the two wheels into proper contact on each side of the tire, thus—the inventor says—putting both sides on at once and making it impossible to pinch or otherwise damage the tube. The tool is being manufactured by M. P. Wood, 141 Simcoe street, Toronto.

THE head of the firm, when walking round the works, spies a young apprentice holding his hammer close up to the head. "Look here, my boy, that is not the way to hold a hammer. When I see a man holding a hammer properly by the end of the shaft I pay him \$15 a week; when he holds it halfway along I pay him \$10 a week, and when he holds it higher up still I only pay him \$5 a week; do you understand?" "Yes, sir," says the boy, "will you please say where I am to hold it? I get \$1.25 a week."

## FUSE TESTER

A SIMPLE, rapid and sure fuse tester is a necessity in any shop. When a heavy current flows through the line it is often one and not two or three fuses which blow. Even in a three-phase circuit it frequently happens that the fuse on only one phase will blow. Hence the necessity of a fuse tester. As a tester nothing could be simpler than a single dry cell with a short length of fine iron wire running from one terminal. The wire should be extremely fine and should be iron because the resistance of this metal is high. Place one end of the fuse on one binding post and touch the free end of the wire to the other end of the fuse. If the fuse is O. K., the wire will become appreciably hot in an instant. At the same time the circuit may be broken before it becomes hot enough to burn.—Motor Age.

## Queries of Interest

### REBORING OR REGRINDING

FROM E. L. K.—Will you kindly give me your opinion as to the merits of reboring as contrasted with regrinding of cylinders? Which type of repair is considered the best?

Reply.—We recommend either method for doing the work, depending entirely upon the shape of the cylinders. For oval cylinders or for cylinders that have been scored only slightly, regrinding is sufficient. Where the cylinders are badly worn, or badly scored, reboring is believed to be the cheapest.

In many cases the old pistons can be used if the cylinders are reground, for in the regrinding process, only a small amount of metal is removed.

If the work is done correctly, either method will prove satisfactory.

### RINGS DO NOT FIT CYLINDERS

FROM M. C. C.—I recently overhauled a Ford engine which had been in service about 16 months. Owner had been troubled with excessive cylinder carbonization. Acting upon the advice of the local supply company's manager, I installed Inland piston rings in the two lower piston ring grooves and McQuay Norris' rings in top grooves of each piston. I ground valves, removed carbon, adjusted bearings, etc.

The car has been run, since the overhaul, about six weeks, averaging 100 miles per week, but the compression is poor and carbon deposits excessive. Plugs foul easily and engine skips unless cleaned regularly. The car is given the best care and it would seem that the rings should work satisfactorily by this time. Can you advise me what is wrong and what can be done?

Reply.—This is one of the troubles with which the manufacturers of leak-proof rings have to contend. The rings in all probability are correctly installed, but it is the cylinders that are at fault. If you will measure the cylinders very carefully you will find that they are worn out of round. The manufacturers are specific in their directions. They say that the rings will not give satisfaction unless installed in perfectly round cylinders.

We do not hesitate in saying that the two types of rings you mention have been giving satisfaction. If correctly installed so that they fit the grooves without binding and without undue side-play they will prevent oil leakage.



# Northern Electric POWER and LIGHT

The complete line of Electric Farm  
Plants and Accessories

PLANTS—WATER SYSTEMS  
MOTORS—HOUSEHOLD DEVICES  
WIRES AND SUPPLIES

Northern Electric Power and Light plants are backed by one of the largest electrical manufacturers and distributors in Canada. For more than twenty years we have specialized in electrical supplies FOR THE FARM.

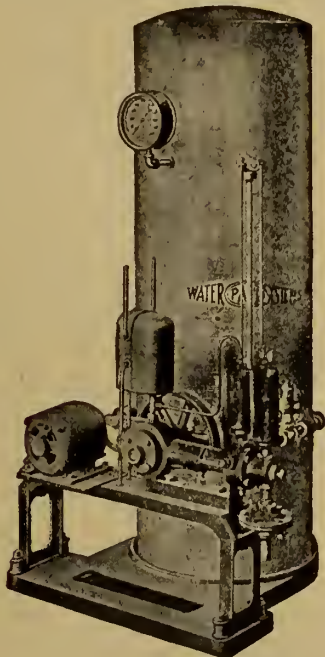

Tank, Pump and Motor

Hundreds of farmers are now buying water systems. Are you selling them? At your service, the most complete line—any size. Automatic — Air-pressure — open tank or hand controlled.

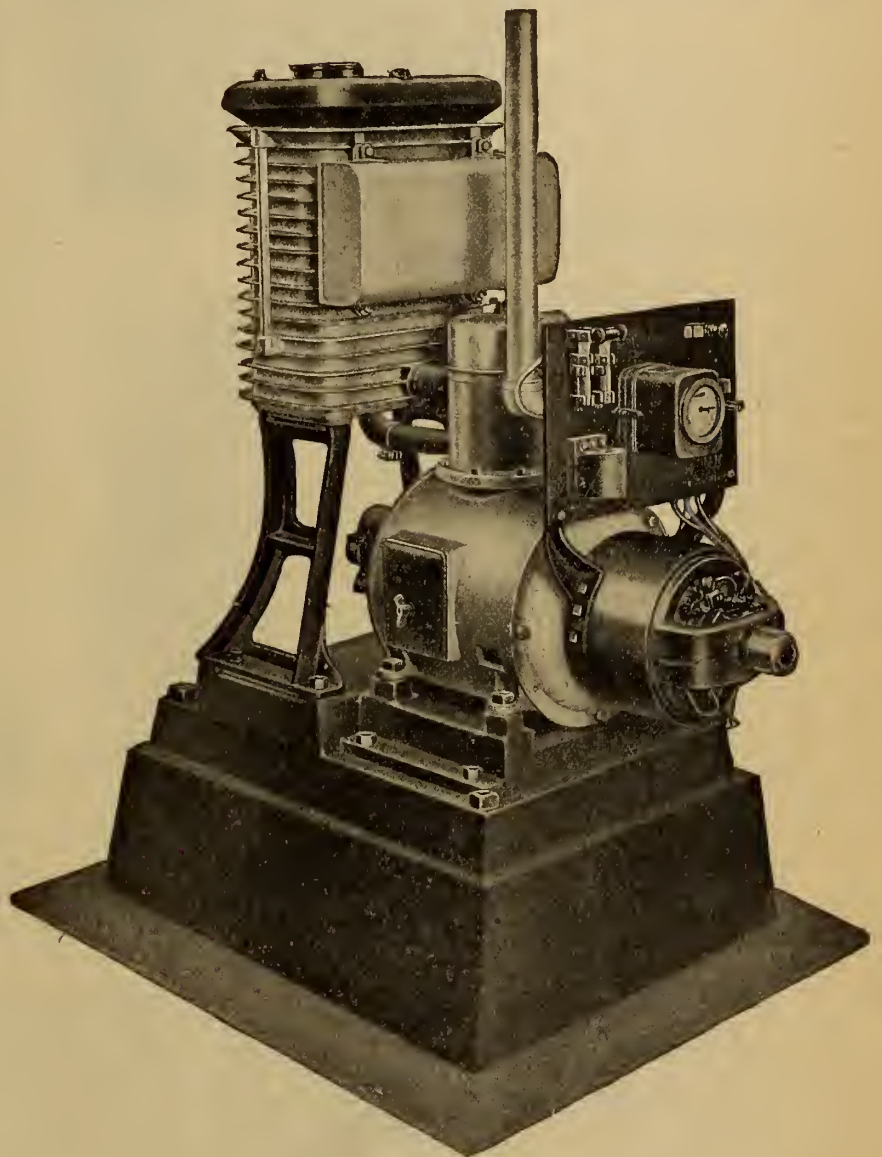

3/4 KW—Utility Plant—32 Volt

*The greatest value ever offered the Canadian Farm*

**DEALERS:**

*The Electric Farm Plant field is practically untouched. Your prospects are numbered by the thousands. You can get into this profitable business by writing our nearest house to-day.*

## Northern Electric Company

LIMITED

Montreal  
Halifax  
Ottawa

Toronto  
London  
Winnipeg  
Vancouver

Regina  
Calgary  
Edmonton



# Automotive Accessories and Implement Equipment

## PORTABLE AUTOMATIC ELECTRIC COMPRESSOR

A NEW automatic electric compressor outfit is being manufactured by the Black and Decker Manufacturing Co., Towson Heights, Baltimore, Md. It is designed primarily for the inflation of pneumatic truck tires, and the heaviest sort of tire inflation service. The motor, gear train and compressor, are enclosed in one housing, the top covering of which is easily removable in three sections.

The makers say the machine is air-cooled; and in a test has run for twenty-four hours, continually pumping against one hundred and fifty pounds pressure. The entire outfit is lubricated by grease, which only requires renewing three times a year.

The cooling chamber at the top of the compressor is provided with fins to dissipate the compression heat. The automatic switch starts the compressor when the pressure in the tank drops to one hundred and fifty pounds, and automatically stops it when the tank pressure has reached two hundred pounds. The possibility of overloading the electric circuit, when the motor is started, is prevented by an automatic unloader.

The outfit is complete with a special air reservoir, tested to four hundred pounds; large pressure gauge; safety valve; twenty-five feet of special woven hose with all fittings, piping and wiring, ready to run. There is a special whistle at the top of the tank providing a means of signalling the garage man in case he is not on hand when a customer wants air.

The carriage and frame are enamelled in B. and D. green; the compressor and tank are grey enamelled and the trimmings are nickelled. As the carriage of this outfit is provided with lugs, it can be easily converted into a stationary tank outfit by merely removing the wheels and handle.



Automatic Electric Compressor



Motor Support

## MOTOR SUPPORT

THE Liberty Motor Support, manufactured by the Motor Support Co., 434 S. Dearborn St., Chicago, for use on Ford cars and trucks, can be installed in twenty minutes. It is claimed that it stops vibration by reinforcing the regular Ford arms with "U" shaped hangers by following the lines of the Ford arms, locking over them on top of the frame and connecting to the saddle on each side of the crank case. It also stops oil leaks if installed before this trouble originates by forming a complete saddle support for the motor and taking the strain off the regular arms. There are no bolts to loosen, no nuts to take off and the support gives a three-point suspension.

## SIPHON AIR WASHER

THE Siphon Air Washer is designed for removing dust particles from the air before admission to the carburetor and cylinder of a tractor. The makers say the entire device is rigidly constructed, the container being of cast iron and sheet metal parts of ARMCO IRON. Large clean-outs, and filler fittings are provided, covers for which are held in place by simple clamping devices. It has no float or other loosely mounted parts, and works upon the principle of injecting a liquid into the air stream.

As the air is drawn through the curved tube, a partial vacuum is created at its lowest point. Water at this point enters and commingles with the air. The tube being comparatively thin and wide, all of the air current is subjected to the spray of water.

After the mixture of water and air leaves the tube, it is impinged against the plate, which forms the partition between the upper and lower chamber of the device, and the velocity of air at this point being relatively low, a part of the water drops from this plate through the air stream; thus again bringing the air and water into contact.

The air then passes upward to the upper, or separating chamber, where, by means of a great reduction of velocity, and properly placed baffle plates, all surplus moisture is deposited and the air is allowed to pass to the motor in a dry but highly saturated state.

When properly connected to the motor, no appreciable amount of vacuum is caused. With the motor at rest, the tube will fill up with water; and when the motor is started, a considerable amount of vacuum will be created in the carburetor until the tube is freed from surplus water. The Siphon Air Washer is made by the Tractor Appliance Co., New Holstein, Wis.

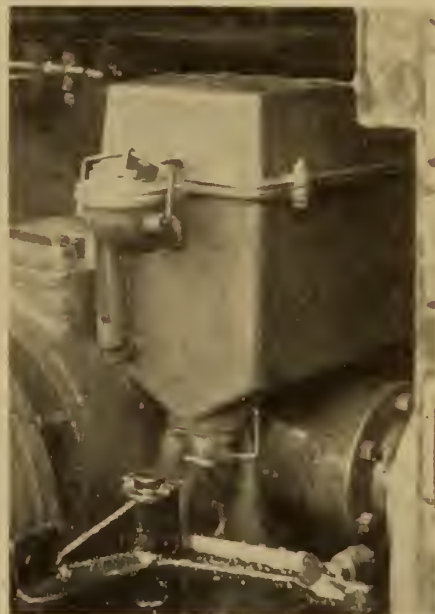

Siphon Air Washer

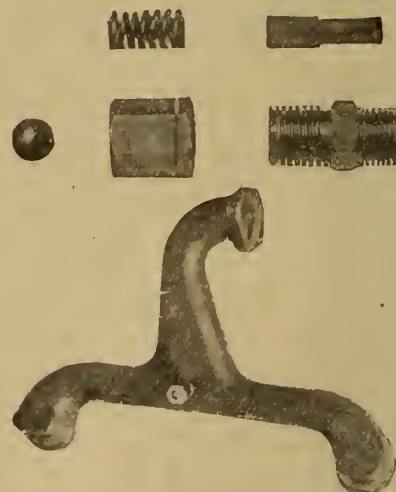

Ha-Maa Automatic Manifold Air Adjuster

## NATIONAL SHOCK LOADER

THIS is a machine constructed for the purpose of loading wagons in the harvest field, with sheaves and bundles in shocks, or loose grain lying in windrows or swaths. The makers, the National Shock Loader Company, Minneapolis, Minn., say that the machine is built of the best materials, including a 4½ x 5 Model B Red Wing Thorobred Tractor Motor, 32-horse-power, and adapted to either gasoline or kerosene.

The principal feature of the loader is the pick-up device, which differs from the old cylinder type, in that it consists of four sets of forks, or tines, which have a movement similar to hand labor. It has an attachment of arms, or rakes, extending beneath each tine, which doubly rakes the ground and picks up cleanly all the loose grain the machine passes over. A full load of grain can be handled by "The National" in four to five minutes.

It is controlled from the driver's seat. The side carrier runs independently of the front carrier and pick-up. The machine can be moved by its traction without running machinery, or can be put in operation and remain stationary. No extra tractor is necessary to pull the loader, for it travels under its own power.

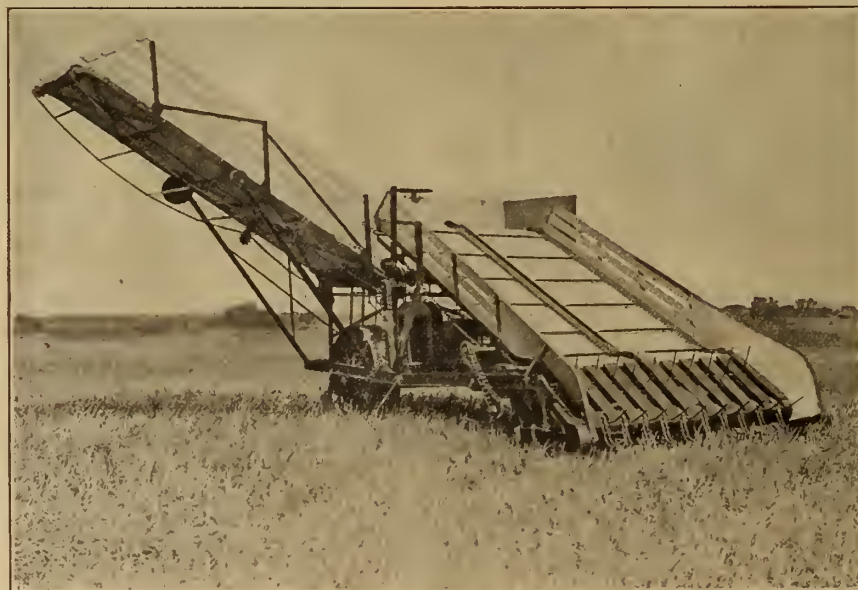

National Shock Loader

## AUTOMATIC MANIFOLD AIR ADJUSTER

THE Ha-Maa Hudson Automatic Manifold Air Adjuster, is manufactured by the Hudson Motor Specialties Co., Philadelphia, Pa. It is designed to automatically adjust the air feed through the manifold, at all speeds. The makers say it is a motor saver and also a gasoline saver. It will keep the motor cool in the hottest days. The Ha-Maa is of simple construction, is very durable and comparatively inexpensive.





Look for the  
EAGLE  
Our Trade Mark

**Bankers Encourage Purchase of Tractors**

**To Develop Agriculture is to Create Wealth**

The functions of the Tractor on the farm are to increase production—to lower expense—to save time. In just such measure as these objects are accomplished,—in just that measure will any farming community prosper.

In just such degree as a Tractor is dependable, durable and simple of operation and maintenance,—in just that degree will it benefit its owner.

CASE Kerosene Tractors are manufactured by the J. I. CASE THRESHING MACHINE COMPANY. For seventy-seven years we have been building superior farm machinery and demonstrating its superiority before offering it. We have never built a failure nor sold an experiment.

Any farmer in your community who needs a Tractor, and wants a Case Kerosene Tractor, has shown one qualification for credit,—good judgment.

If his health and character are as good as his judgment, help the whole community by helping him!

**J. I. CASE THRESHING MACHINE COMPANY, Inc.**  
Dept. O-1, Racine, Wis., U. S. A.  
Makers of superior farm machinery since 1842

**J. I. CASE THRESHING MACHINE CO. INCORPORATED RACINE WIS. U.S.A.**

NOTE: We need the public to understand that our name is not the same as the J. I. Case Plow Works. To avoid confusion, the J. I. CASE THRESHING MACHINE COMPANY is now distributing its American-made tractors under the name of Case Plow Works, Inc. and its Canadian-made tractors under the name of Case Plow Works (Canada), Inc. The J. I. Case Plow Works Company.

## Make Allies of Your Local Bankers!

The wide-awake banker is a power for progress in his—in your—community. He is quick to translate into terms of dollars and cents the value of Case Power Farming Machinery in conserving labor,—increasing production—creating wealth.

But the banker "must be shown"! And the more he knows about you, and the reliability, power, and simplicity of operation of the products of the J. I. CASE THRESHING MACHINE COMPANY, which you sell, the more readily will he help to finance purchases by your customers.

For your benefit, Mr. Dealer, we are running full page advertisements in

every issue of the leading magazines devoted to banking and read by bankers. One of these advertisements is here reproduced in miniature.

Make allies of your local bankers. Tell them of the superiority of Case Power Farming Machinery as you know it; that the famous old trade mark of the Eagle on the Globe stands for reliability—for 77 years of building of successful farming machinery.

Along this line exists a real opportunity for you as dealer in, and the company as builders of a great line of farm machinery that is *right* agriculturally as well as mechanically. Do your part locally as we are doing our part nationally.

**J. I. CASE THRESHING MACHINE COMPANY, Inc., Dept. O-1, Racine, Wis., U. S. A.**  
*Making Superior Farm Machinery Since 1842*

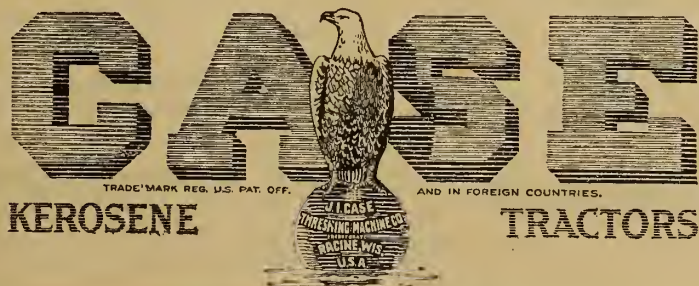



# Have you got your test for this tried and proven

**R**ENFREW Truck Scales are selling quickly everywhere our agents show them. Jonas Hagerman's record of \$3405 in commissions for five months, due to handling them in car-lots, is going to be eclipsed by many of our agents who are likewise busy in this "gold mine", as Mr. Hagerman calls it. The ground has hardly been scratched. If you are open for a tried-and-proven-rich WINNER right from the word go, it's time you were selling the

## Renfrew Truck Scale

Don't get the idea that the government inspector in the picture is testing this scale for accuracy alone. The government

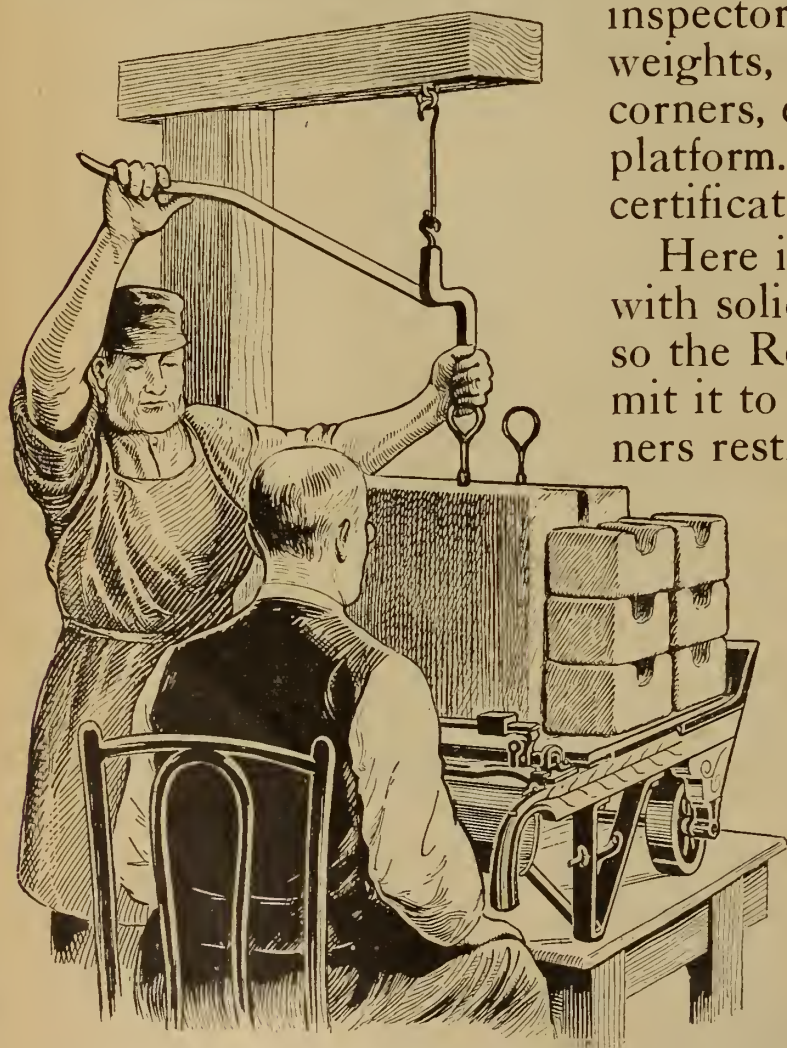

inspector tests the Renfrew for all weights, from a pound to a ton, on corners, ends, sides and centre of the platform. Every scale carries a certificate of correct weights---and our guarantee.

Here is the big idea: The ordinary stationary scale with solid contact points must stand *level* always. Not so the Renfrew. Its self-adjusting contact points permit it to weigh with precise accuracy with the four corners resting either on level or slanting ground. Con-

### Big Money in Car-Lots

"You save money when you handle these scales in car-lots," writes Jonas Hagerman. And think of the big cheques you can have from the larger turnover. Mr. Hagerman's average monthly commission during 5 months was \$681 per month, or a total of \$3,405.00. This is at the rate of over \$8,000 a year! Write us for terms on car-lots.

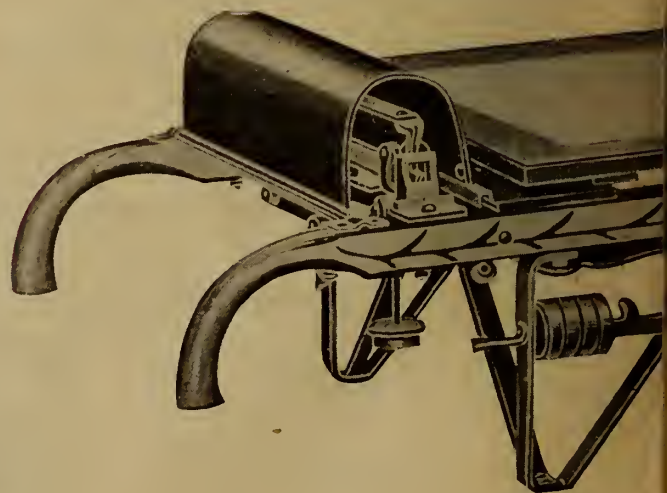

A Government Certificate with Every Scale

# The Renfrew Machinery Company, Ltd.

AGENCIES ALMOST EVERYWHERE IN CANADA

EASTERN

Other Lines: Renfrew Cream S



# Territory yet WINNER?

**BIG  
MONEY  
IN  
CAR  
LOTS**

sequently, it must weigh correctly on every square inch of the platform.

You see that the Renfrew gives all the accuracy and service that a clumsy platform scale can give—and then a lot more service besides. And the Renfrew costs *less* than the old-fashioned scale. The farmer is quick to see its value, too. Hence your easy sales.

Lugging heavy bags to the platform scale is a back-breaking, time-wasting job. Just stick the nose of the Renfrew truck under the bag and tip it up. Easy!

Think of the money farmers lose through wrong guesses of weights when selling live stock on the hoof! Imagine weighing a cow on a platform scale! With the Renfrew and a little platform arrangement, it is no trick at all to weigh everything from a hen to a horse.

Where's the thinking farmer who is proof against the accurate scale that is also a truck and a stock weigher? He can weigh anything anywhere on uneven ground. And

he can back up the accuracy of his weights against those of any other scale on earth.

Remember. If Jonas Hagerman, and other Renfrew agents, can make big money handling Renfrew Scales in car-lots—so can you. It is the prince of easy sellers!

**Renfrew  
SCALE**

## Secure Your Territory NOW Every Day Counts



You know how men rush to the gold fields. That is what they're doing on this proposition which Jonas Hagerman rightly calls a regular "gold mine." Our literature is free for the asking. Write for it and terms today.

**"A Gold-  
mine"**

Jonas Hagerman



*The End Test*

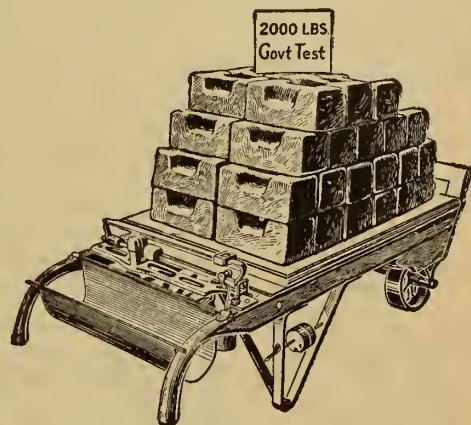

*The Heavy-weight Test*

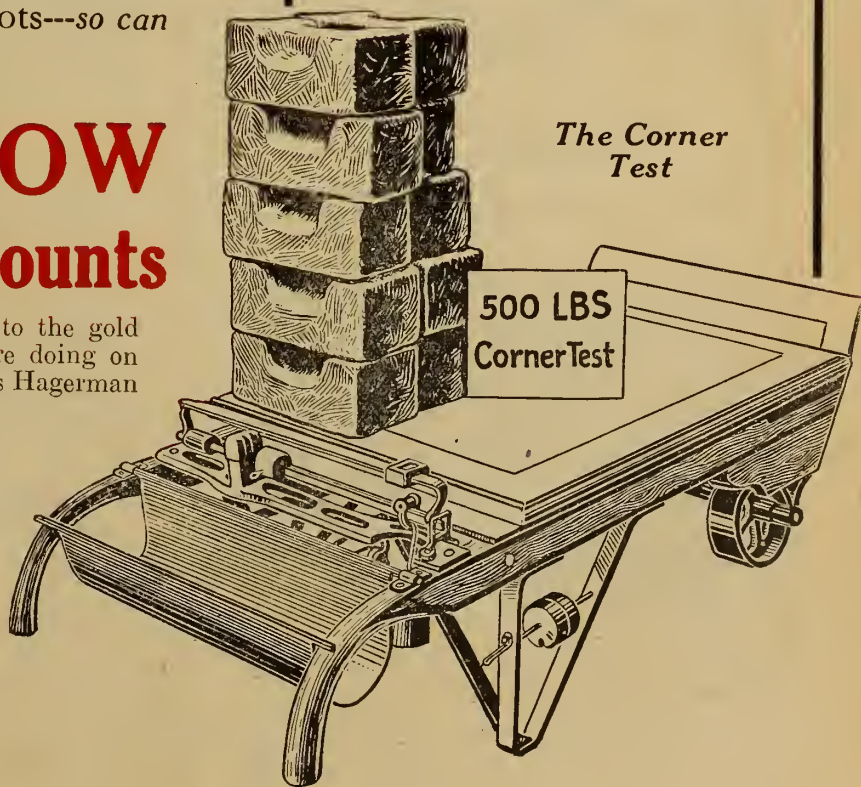

*The Corner  
Test*

imited, Head Office and Works: **Renfrew, Ontario**

ANCH, SUSSEX, N.B.

QUEBEC BRANCH, MONTREAL, QUE.

ator—Happy Farmer Tractor



## "Casco" Coil Box Protector

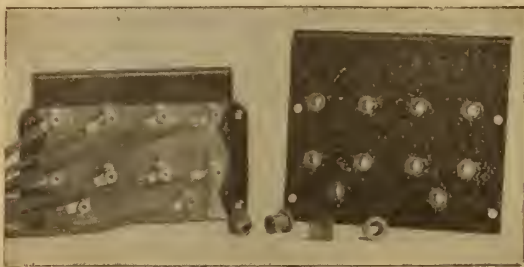

*The Only Protector for FORD CARS  
Against Rain and Wet Weather*

Ford cars frequently stall in wet weather. The water works in between the hood—into the coil box, causing short circuit.

This inconvenience is prevented if you use the "Casco" Box Protector. It covers the Ignition and Coil Box.

Dryness is guaranteed.

Without Rubber ..... \$1.00  
Rubber Insulated ..... 1.50

## "Casco" Fan Belt Guide

Put on in  
a Minute



50 c.

Clamps here  
to Crank Case  
Flange

Clamps here to  
Crank Case  
Flange

## "Casco" Oil Drain Cock



Pat. Oct. 7, 1919

The "Casco" Oil Drain Cock is Automatic in action. No cock wrench is required.

No Ford owner should be without one, as it enables him to easily keep close tab on the oil level and prevent unnecessary wear of bearings.

Complete, per pair, \$1.50

## Hold 'Em in the Road

\$5.00



"Hold 'Em in the Road" for Ford Cars

Here it is, the Radius Rod Brace, Anti-Rattler Axle Support and Safety Device all in one.

There is no Ford car accessory made that possesses such a strong combination of strength and safety.

Fits all model Fords to 1919 inclusive.

# Sell These Ford Necessities

**Every Ford Owner in Your  
Vicinity is a Good Prospect**

Put this claim to the test by showing a Ford owner some of "Casco" products. He will go away with one or more of them—you make a sale and a good profit.

**CASCO MANUFACTURING CO.**  
THOMASVILLE, GA., U.S.A.

Canadian Registration Applied for

**A. H. Frazier, 1150 Homer St., Vancouver, B.C.**  
*Manufacturers' Agent*

**CANADIAN JOBBERS**  
Merrick-Anderson Co., Limited, Winnipeg  
John Millen & Son, Limited, Montreal, Toronto



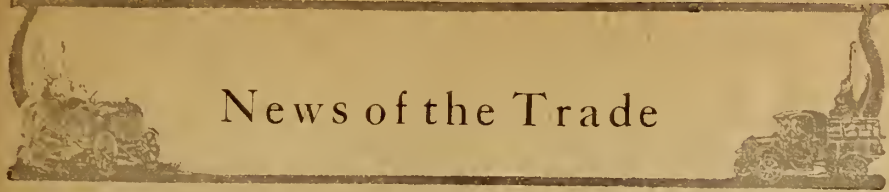

## News of the Trade

**ONTARIO**

**CLINTON.**—A. Seeley has branched out and, in addition to his machine shop, now has erected a garage, 80 x 100.

**TORONTO.**—The C. and C. Motors, Ltd., capital \$100,000, head office Toronto, will manufacture and deal in autos and auto accessories.

**WALKERVILLE.**—The Hills Jansen Company, Ltd., capital \$40,000, head office here, has been incorporated to manufacture and deal in auto accessories.

**GRAND VALLEY.**—T. H. Hamilton, dealer in Canadian Ford cars, accessories and repairs, is building a new garage which will be ready in the spring.

**HAMILTON.**—The Universal Battery Company, Ltd., head office here, capital \$40,000, plans to carry on a general automobile repair business and deal in batteries and accessories.

**SEAFORTH.**—E. Mitchell and Sons have taken over the Adams garage. They have the Overland agency and will specialize on battery work. B. T. Reid will handle the repair end.

**SARNIA.**—Seagrave, Loughead Co., Ltd., will manufacture automobile fire department apparatus, heavy commercial trucks, trailers and semi-trailers. Stock in the company is now being sold.

**WALKERVILLE.**—A company engaged in the manufacture of brakes and clutches has purchased a plant on Argyle road for \$40,000. Operations are expected to commence this month.

**HAMILTON.**—The Firestone Tire and Rubber Company of Canada, Ltd., capital \$5,000,000, with head office here, will manufacture and deal in rubber products, automobile accessories and metal rims.

**LONDON.**—A new automobile show room will be opened shortly, opposite the Grand Theatre, by Messrs. O'Brien, Sheraton and Pennock. The new concern has secured exclusive agency of the Dodge car for Middlesex County.

**BELLEVILLE.**—A Canadian company, known as the H. A. Wood Company, Limited, has been formed, and is being incorporated, with a capitalization of \$1,000,000. The company has obtained the Dominion rights of an American concern for the manufacture of automobile valves.

**BLLENHEIM.**—Bruce V. Cameron, of Woodstock, and T. Dymond, of Goderich, have bought the automobile plant and equipment of E. W. Knight. They will also take over the Ford and McLaughlin agencies. The change will take effect in a few weeks, but Mr. Knight is to remain with the new proprietors for some time. Both the men are returned soldiers.

**TORONTO.**—A school of instruction in tire repairing and vulcanizing is being conducted by the Goodyear Tire and Rubber Co. in their factory at New Toronto. The instruction is free, and is given by experts, to anyone desirous of learning this part of the automobile business. The course is continuous, and the student may remain as long as he chooses.

**HAMILTON.**—The employees of the International Plow Works recently presented George X. Beaudway, who is severing his connection with the plant, with a handsome watch and Masonic ring. A. C. Dann, superintendent, made the presentation. Mr. Beaudway was the works' auditor, and has been identified with the works since ground was first broken for the plant.

**MANITOBA**

**WINNIPEG.**—A permit has been secured by the Western Canada Motor Company for the erection of an additional storey to their premises on Edmonton Street, at a cost of \$17,000.

**WINNIPEG.**—The distributor for the G. M. C. trucks, for the whole of Saskatchewan and Manitoba, is the Cadillac Motor Sales Co. of Winnipeg. A first shipment has reached the company.

**WINNIPEG.**—The Winnipeg Automobile Club held its annual banquet at the Fort Garry Hotel recently. In the absence of Premier Norris, the Hon. G. A. Grierson presided. There was an attendance of about 500.

**GLADSTONE.**—The McAskill Adamson Co., Ltd., who purchased the hardware business of Williams Hardware Co., Ltd., and the implement business of Nichol Hornsby, will operate both businesses in the Williams Block. The implement side of the business is under the care of "Rod" McAskill.

**SASKATCHEWAN**

**REGINA.**—General Motors, Limited, organized with a capital of \$200,000, is locating here.

**REGINA.**—The Goodyear Tire and Rubber Co. has decided to build offices and warehouses in Regina, in an effort to increase its trade in the Province of Saskatchewan. A site has been secured, and the company proposes to spend \$75,000 in opening up the new Saskatchewan headquarters.

**SASKATOON.**—The Saskatoon branch of the McLaughlin Motor Car Company, Ltd., held its first annual banquet recently in the King George Hotel. About thirty of the employees and guests were present. The program was under the direction of J. D. Leach. It was decided to make the banquet an annual affair.

**REGINA.**—The Legislative Committee of the Saskatchewan Grain Growers' Association, at a recent meeting, decided to lend its support to the movement to secure legislation compelling auto dealers to carry repairs for autos sold by them for a period of five years after they have ceased to sell such automobiles.

**WOLSELEY.**—The J. I. Case Threshing Machine Co. held a tractor school here on January 6, 7, 8 and 9, in the Wolseley Garage building. The course, which was free, was the same as that given in Regina and other large centres and was conducted by experts provided by the company.

**SASKATOON.**—The John East Machine Company recently built a new type of threshing machine for deseeding flax, for the Dominion Experimental Farm at Ottawa. The machine was designed by F. W. and F. L. Van Allen. It is intended to do away with the hand pulling system used in threshing up till now.

**ALBERTA**

**RED DEER.**—All local garages have increased their storage rates from January 1: live, \$8 per month; dead, \$6.

**MORINVILLE.**—John Graf, who has branches at Bon Accord as well as here, has built up an annual business of \$122,000 in the eight years he has been here, he states. Pretty good for a town this size, and with keen competition.

**MORINVILLE.**—The automotive business has grown apace in this, one of the most progressive French settlements in Northern Alberta. The Central Garage, E. C. Cournoyer, proprietor, reports a monthly turn-over in excess of \$3,000.

**BRITISH COLUMBIA**

**ABBOTSFORD.**—C. Spring has purchased the K. and K. Garage from Mr. Krevouski.

**CLOVERDALE.**—The Highway Garage, under the management of Mr. Carmichael, is now open for business.

**UNION.**—Ground has been obtained by Mr. Neil, formerly of the B. C. Telephone Company, for the erection of an up-to-date garage.

**VANCOUVER.**—The McCandless Motor Company has erected an up-to-date garage in Howe Street. They specialize on Diamond "T" trucks.

**CHILLIWACK.**—S. Patterson has been appointed manager of the Canadian Garage, which handles Studebaker cars and Ever-Ready Storage Batteries.

**CHILLIWACK.**—Frank Edwards and S. Parlow have opened a new garage under the name of the Chilliwack Garage. They have the Gray-Dort agency.

**VANCOUVER.**—Mr. Knight of Calgary has bought the interests of Mr. Ferguson, of the Ferguson-Higman Motor Company. The business will still be carried on under the old name.

**MISSION CITY.**—Stuart and Miller now handle the agency for Chevrolet and Dodge cars. They complain of not getting enough of them to meet the demand of their rapidly growing business.

**VANCOUVER.**—Albert Wilson, formerly master mechanic of the Vancouver Fire Department, along with other two mechanics, has opened an up-to-date garage, to be known as the Rotary Auto Machine Shop.

**VICTORIA.**—Capt. Carl All, of the firm of Pattison and All, Vancouver, distributors in British Columbia for the "Roamer" Motor Cars, was in the city recently with the idea of establishing an agency for the Roamer car.

**VANCOUVER.**—Edward B. Welch has received a permit to erect a large two-storey garage and service station on Howe Street. The new garage will be of reinforced concrete and tile construction, and will cost \$24,400. Work on it will be started at once.

**MARITIMES**

**CHARLOTTETOWN, P. E. I.**—At a meeting of the Retail Merchants' Association, Hon. George E. Hughes, member of the Government, announced recently that the Government is planning to take advantage of the Federal road grant and expect to expend \$400,000 on roads next year.

**FREDERICTON, N. B.**—Phillips and Pringle, Limited, have been incorporated with a capital stock of \$49,000. The company will deal in motor vehicles, gasoline tractors and motor accessories.

**ST. JOHN, N. B.**—The body of William McDonald was found in the City Garage one night recently, his death being done, apparently to patrol fumes.

**E. S. WEST APPOINTED EMPIRE SALES DIRECTOR**

**THE Empire Cream Separator Company** advises us of the appointment of Mr. E. S. West as their Canadian Managing Director in full charge of their Montreal office and also governing the business activities of the Toronto office.

Mr. West comes well qualified for this important position. He has had years of good successful experience and knows the Canadian sales conditions thoroughly. He became first associated with the Empire Company as stenographer and order clerk, at the Portland office, and by reason of his ability became chief accountant, and later credit manager of the Portland office. Mr. West succeeded so well that he was appointed manager of the Denver office, in which capacity he served for some time. He is now assistant at the Canadian office taking full part in directing and managing Canadian activities.

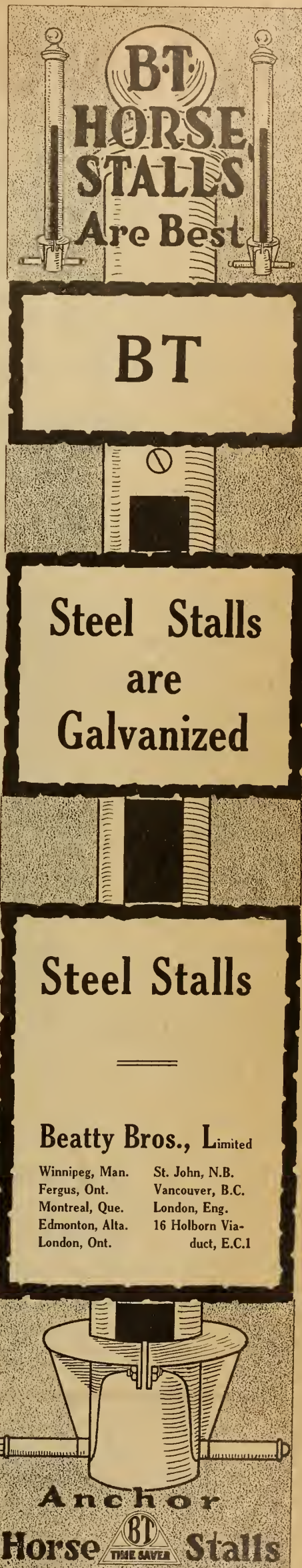

**B.T. HORSE STALLS Are Best**

**BT**

**Steel Stalls are Galvanized**

**Steel Stalls**

**Beatty Bros., Limited**

Winnipeg, Man.	St. John, N.B.
Fergus, Ont.	Vancouver, B.C.
Montreal, Que.	London, Eng.
Edmonton, Alta.	16 Holborn Via-
London, Ont.	duct, E.C.I.

**Anchor Horse Stalls**



# ANNOUNCING

# The VET

Designed by  
Financed by  
Built by  
in a

## Canadian

Engineers  
Capital  
Workmen  
Factory

Note the  
Wheelbase  
Loading Space  
Engine  
Governor  
Carburettor  
Muffler  
Clutch  
Transmission  
Shaft  
Axles  
Steering Gear  
Wheels

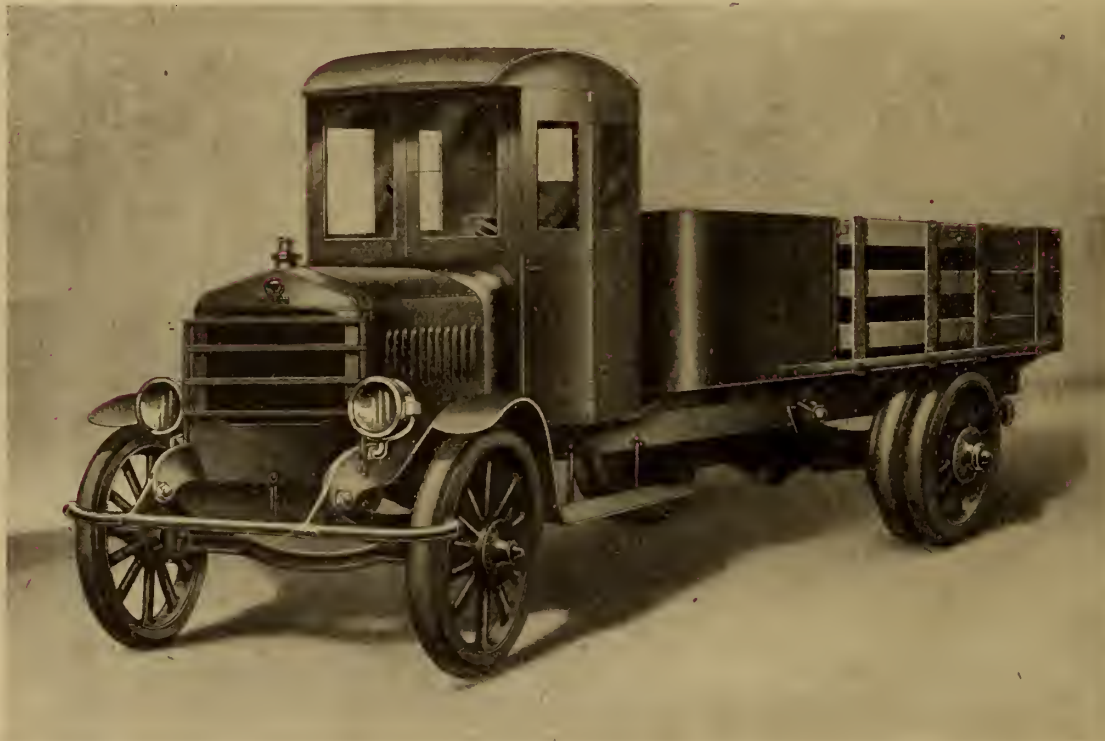

2-Ton Model complete with Cab and Stake Body

## Our Guarantee

Our Guarantee is not a scrap of paper, but REAL MONEY and apart from this Cash Guarantee the makers stand behind their product at all times.

There is room in our organization for capable dealers who want to handle a line of quality and profit---Write about territory.

---

EASTERN CANADA MOTOR  
HULL

---



# ERAN

Dependent, Economical in operation and adapted to efficient service in every line of business.

## OUR CREED

We believe in building the best truck possible regardless of price.

We believe in dealing fairly and squarely with dealers and purchasers.

We believe in maintaining at all times the good will of all with whom we do business.

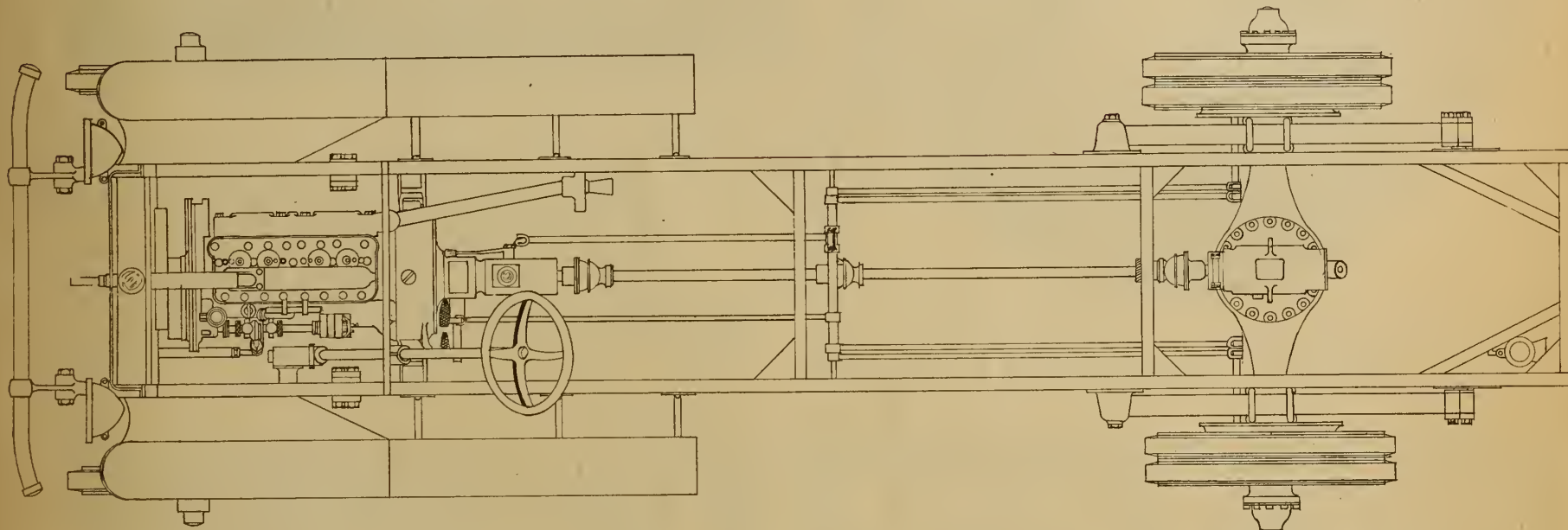

### Specifications 2 Ton Model

<b>WHEELBASE</b>	156 inches.	<b>REAR AXLE</b>	Sheldon Worm.
<b>LOADING SPACE</b>	Back of seat to end of frame—141 inches.	<b>FRONT AXLE</b>	Sheldon dropped forged "I" Beam.
<b>TREAD FRONT</b>	58 inches.	<b>BRAKES</b>	Two sets, internal expanding.
<b>MOTOR</b>	Buda, Model HTU, 4 cylinder three point suspension. Bore $4\frac{1}{4}$ in., Stroke $5\frac{1}{2}$ in. Detachable cylinder head. Developing 33.1 h.p. at 1100 revolutions.	<b>FRAME</b>	6-in. Rolled Channel. Width 34; in. overall 19ft. 7 in.
<b>GOVERNOR</b>	Simplex. Model M	<b>SPRINGS</b>	Crome Vanadium Steel—Front; Semi-elliptic 42 in. long. Rear; Semi-elliptic 52 in. long.
<b>CARBURETTOR</b>	Zenith.	<b>STEERING GEAR</b>	Ross Irreversible, worm and nut type. 18 in. hand wheel. Left hand drive
<b>MUFFLER</b>	Vacuum type	<b>GAS TANK</b>	Capacity, 17.5 Imperial gallons. Mounted underneath seat, with filler opening at right side of cab.
<b>IGNITION</b>	Eisemann Model GU4, high tension Magneto, with impulse starter.	<b>WHEELS</b>	Smith Steel Wheels
<b>COOLING SYSTEM</b>	Tubular Radiator "built up" type, cast top and bottom tanks. Pump circulation.	<b>TIRES</b>	36 x 4 in. front. 36 x 4 in. dual, rear. Pneumatics furnished at extra cost.
<b>CLUTCH</b>	Borg & Beck Dry Disc type, completely enclosed in bell housing.	<b>CONTROL</b>	Gear shift and brake lever-mounted in centre of chassis. Equipped with accelerator pedal and hand spark and throttle controls on steering column.
<b>TRANSMISSION</b>	Cotta constant mesh type, four speeds forward and one reverse.	<b>CAB</b>	Solid steel cab with demountable doors furnished as standard equipment. Locker for tools and retainers for spare oil, gas and water, on left side. Trap door on right side to accommodate gasoline filler.
<b>PROPELLER SHAFT</b>	Spicer 3-joint shaft with S.K.F. self-aligning centre bearing.		

# TRUCK COMPANY, LIMITED

- P.Q.



# Hold Tite Nut Lock

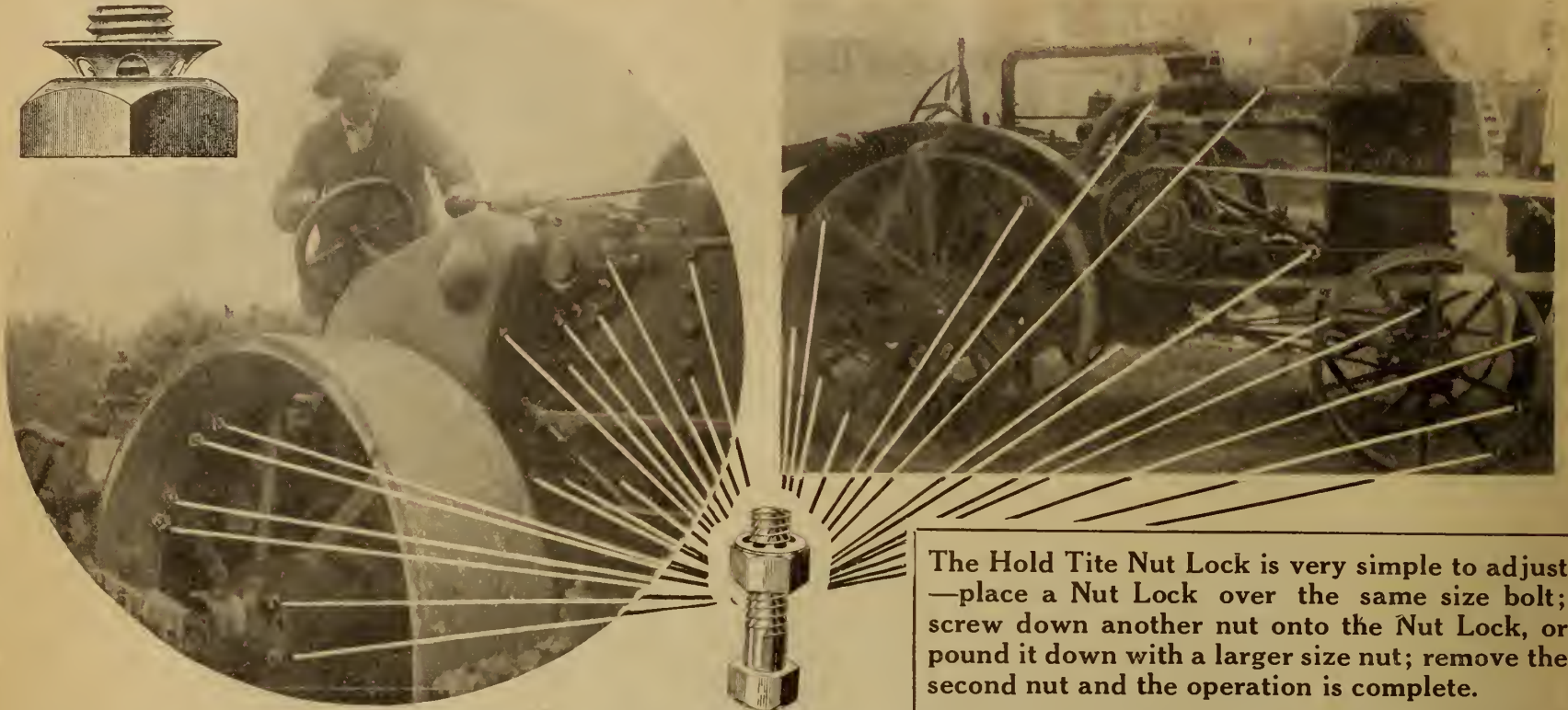
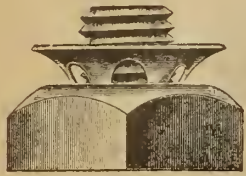

The Hold Tite Nut Lock is very simple to adjust—place a Nut Lock over the same size bolt; screw down another nut onto the Nut Lock, or pound it down with a larger size nut; remove the second nut and the operation is complete.

The Hold Tite Nut Lock is a simple, inexpensive but positive appliance. A safeguard wherever a nut needs locking.

Applied to automobiles, trucks, tractors, stationary engines and all kinds of agricultural machinery, this invention makes each bolt as tight as a rivet.

The cost is little because the construction is economical. There is no waste material. Every particle of the lock does its work.

Nothing could be more efficient. The nut lock holds on like grim death. No vibration can shake it off; the nut is there to stay when this little collar of steel is pressing it into position.

Start your patrons off right by equipping the machines you sell them with Hold Tite Nut Locks. Sell the Nut Lock to those who have already purchased machines.

Write to us to-day for full particulars.



Manufactured  
Only By

Some of the  
Satisfied users  
of the Hold  
Tite Nut Lock

Canadian Pacific  
Railway Co.,  
Montreal.

Canadian Vickers  
Co., Montreal

Renfrew Electric  
Co., Renfrew,  
Ont.

Canada Cement  
Co., Montreal.

Packard Electric  
Company.

Gray and Davis,  
Inc.

Electric Auto-  
Lite Corp.,  
Toledo.

Grandall Packing  
Co., Boston,  
Mass.

**EDWARD A. ROBINSON CO., LIMITED**  
228 CRAIG St. W. AMERICAN FACTORY: WALTHAM, MASS. MONTREAL



THE COMMERCIAL CREDIT COMPANY OF CANADA LIMITED

IS

A CANADIAN COMPANY offering service of interest to and in the interest of Canadians.

Time payments made possible and profitable for Manufacturer, Dealer and Customer. Of particular interest to Automobile and Musical Instrument Trades.

LET US KNOW YOUR REQUIREMENTS

THE COMMERCIAL CREDIT COMPANY OF CANADA LIMITED

Bank of Hamilton Building, Toronto, Ontario  
McArthur Building, Winnipeg, Man.

WE GIVE

**“Quality and Service”**

IN

TRACTOR and TRUCK  
STEEL CASTINGS

**JOLIETTE STEEL CO., LIMITED**

903 Read Building, Montreal  
JOLIETTE, P.Q.

The Sign of Quality

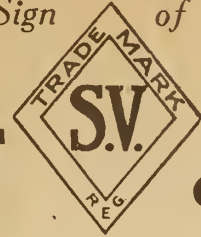

**VESSOT**

**FEED GRINDERS**

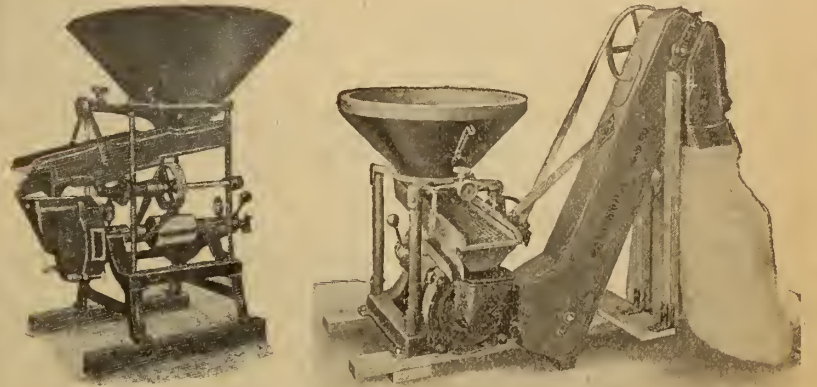

Elevator and Bagger

Wherever you find a “Vessot” Grinder you will find a contented user. The “Vessot” always satisfies.

Vessot Grinders have obtained medals and highest awards wherever exhibited—Chicago, Paris, etc.

We make nine different sizes of grinders 6½”, 8”, 9”, 9¼”, 10½”, 11” B Farm Type and 11”, 13” and 15” Mill Type, or in other words, we build a machine to meet any requirements.

The agency for Vessot Grinders will net you a good commission. May we mail you our proposition?

INVENTORS AND MANUFACTURERS

**S. VESSOT & COMPANY, Joliette, Que.**

Sold exclusively in Canada by

International Harvester Co. of Canada, Limited.

Branches: Calgary, Edmonton, Lethbridge, North Battleford, Regina, Saskatoon, Yorkton, Brandon, Winnipeg, London, Hamilton, Ottawa, Montreal, Quebec, St. John.



# TURNER

## Simplicity

### The Tractor You Sell

is only as attractive as the tractor is tried and proven, practicable, and economical in operation. Continued sales, easy service demands, and contract renewals throughout the country prove that Turner success is hinged upon built-in principles of proven merit, of economy and service.

Turner Simplicity has met the demand for a tractor that can be relied upon for constant performance on a wide range of work. On drawbar and pulley jobs the efficient delivery of power to wheels and belt has won Turner lasting reputation.

Its reserve power to meet overload conditions, its low fuel costs, easy handling and thorough dust protection, contribute to the increasing sales records that have grown apace with production facilities.

It is significant that the Turner is handled by leading distributors the country over. For immediate action on territory proposition—address

**The Turner Manufacturing Co.**

441 Lake Street, PORT WASHINGTON, WIS.

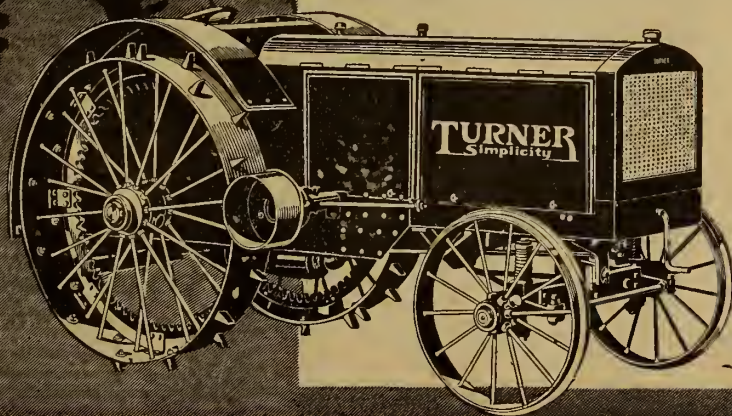



### HYDRATE ELECTRIC BATTERY OVEN

SERVICE station and garage men who handle battery repairs will find this device useful in removing the jars and covers.

It consists of a metal box open at the bottom, and containing three electric heating units in upper portion. The back of the box is attached by means of a bracket, to an upright pipe standard, and held in position by a thumb screw, making it easily adjustable.

The oven is 21 $\frac{3}{4}$  inches long, and 9 inches wide inside. It will hold any standard starting, lighting, and ignition battery. The heating units are designed for any 110 to 115 volt lighting circuit, either direct or alternating current.

The makers say the power required is one and one-half kilowatts. The front side of the oven is hinged and may be opened to examine the condition of the battery being heated. It is shipped completely assembled and ready for installation. The manufacturers are the Service Station Supply Co., Detroit, Michigan, U. S. A.

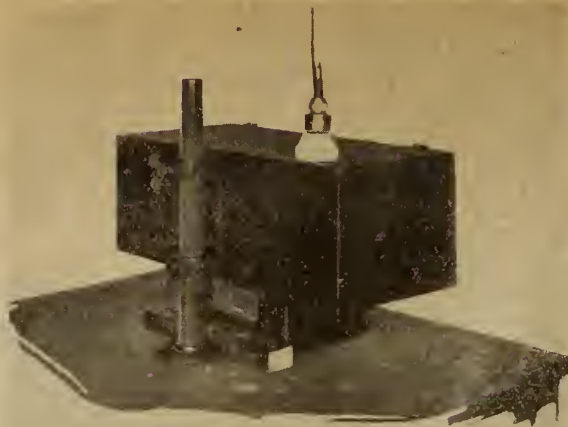

Hyrate Battery Oven

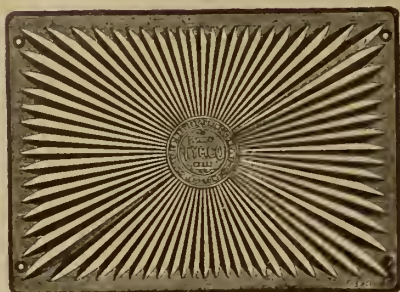

Tyler Safety Step Plate



Speed Nut Wrench

### ELECTRIC GAS PRIMER

THIS is a starting device and battery saver, electrically operated. It consists of a copper tubing, wound in spiral form, surrounded by an electrical heating unit, composed of iron wire, insulated with asbestos; the entire unit is covered with asbestos and placed in the centre of a brass container known as the bowl.

The primer is operated from a dash pump. The process is to turn on a dash switch, giving one or two injections of gasoline by the dash pump, which forces the gas through the heating coil and comes out in the form of a hot vapor, which is sucked into the engine, forming a highly explosive mixture which ignites instantly in the coldest weather. The primer is placed as near the intake manifold as possible.

The makers, the Auto Distributing Co., Plainfield, New Jersey, say the outfit is self-regulating inasmuch as the iron wire, upon heating, automatically shuts off the current due to the rapid rise in its resistance.

It starts with twenty amperes and in a few seconds registers the minimum consumption of seven amperes. It can only be used on cars equipped with storage batteries. The primer is distributed in Canada by the Canadian Fairbanks-Morse Co.



Hollingshead Electric Tool, Removing Nuts

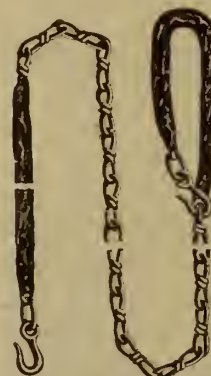

Bulldog Towing Chain

### NEW AUTO RECORDER

WILLARD CHIPMAN, of 219 Concord Avenue, Toronto, has invented a new device known as the Chipman Auto Recorder. The invention keeps a record of the speed made at every hour and minute during the day. The instrument is nine inches long and four wide, and is set in the dash of the car. On the right is a speedometer and on the left a clock. A pencil in the centre operates on a chart and indicates the exact speed made by the car. The clock controls a tape and the speedometer controls the pencil, which writes on the tape.

The tape is on a spool similar to a kodak film spool. The spools are made to last a day or a week, and are divided horizontally into mileage spaces, and vertically into five-minute spaces.

The recorder will show exactly at what minute you were running, or when you stopped, and at what speed you were running at any particular time. When the car stops, the clock continues to run, and a blank space is shown on the chart.

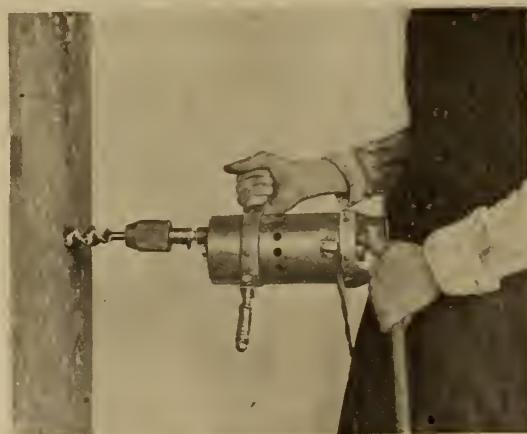

Hollingshead Electric Tool, Showing Boring Operation

### MOTOR HEATER

THE Myall Motor Heater, which is manufactured by Motor Sundries, Limited, 420 Foy Building, Toronto, may be installed in ten minutes, without any trouble. The manufacturers claim that it is adaptable for use in any of the standard makes of cars, and that it will keep the engine warm and

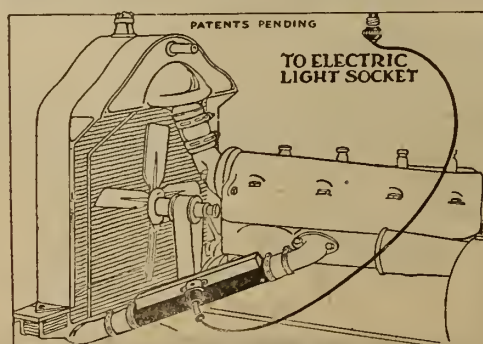

Myall Motor Heater

ready for instantaneous service, in any garage, in any weather. It is quickly attached to any electric light socket.

### SAFETY STEP PLATE

THE Tyler Manufacturing Co., Boston, Mass., have put on the market a new safety step plate for the running board of automobiles. The makers say it provides an absolutely sure footing and keeps the inside of the car clean. The step plate has an upper surface made in a solid compact form, which will retain its appearance and shape. The ribs will not break away in use, and there is ample space between them to take care of whatever dirt is removed from the boots. The type D plate, shown in illustration, is made of black rubber, with red rubber centre. The makers can supply the type D step, bearing the name of the car, at short notice.

### THE COCHRAN SPEEDNUT WRENCH

THIS is a handy wrench with a rapid automatic adjustment to fit any size of nut. It is manufactured by the Cochran Manufacturing and Forging Co., Chicago, Ill., who say it is simple in construction, having only three parts, is very powerful and durable. It is made in two sizes: a 6-inch, weighing 7 $\frac{1}{2}$  oz., and an 8-inch, weighing 17 oz.

### HOLLINGSHEAD ELECTRIC WRENCH

THE Hollingshead electric wrench, drill and screw driver, is a new power driven combination wrench by screwed in place and removed without danger of breaking the bolts or stripping the threads. It is a light hand tool that makes available in a safe and efficient way large amounts of power for a considerable number of uses. The machine weighs about 14 lbs., the body is 10 inches long and four inches in diameter. The power is obtained from a small high speed electric motor encased in a metal cylinder with specially arranged gears and worms. The motor operates in either direction, having three speeds forward and three speeds in reverse.

The makers say the electric wrench can be used for power drills for any size portable drill or revolving tool used by miners or stone cutters. Under proper conditions it will do the work much faster and cheaper than can be done by any other portable power tool. It can also be used for grinding auto cylinders and valves. This tool is made by Hollingshead and Co., 55 Liberty Street, New York.

### BULLDOG TOWING CHAIN

THE Chain Products Co., Cleveland, Ohio, have placed on the market a towing chain known as the Bulldog Towing Chain. The makers say the links are unusually heavy and strong and the hook at each end is drop forged. Both ends of the chain are covered so that the enamel of the car towing or being towed can in no wise be scratched by the links. The chain is made of 5/16 in. material with a tensile strength of 4,400 lbs., and is 18 ft. long.

### BENCH JOINTER

AN interesting machine has been developed by J. D. Wallace and Company, Chicago, known as the six-inch Wallace Bench Jointer. The machine is portable and can be carried by one man. It is equipped with its own motor and can be operated from an ordinary lighting circuit by lamp cord and plug, which it carries. A fence is mounted on the motor, and slides backward and forward on rods. The cutter head is easily removed, say the makers, and other heads inserted.

The device is designed for doing small work right at the bench.





*IN spite of a far higher selling price, Bethlehem Tractor Plugs are the largest selling tractor plugs on the market.*

The International Harvester Company and other prominent tractor manufacturers use them as standard equipment. Price is no argument, because performance—*real performance*—is built into every plug.

Stock the Bethlehem line of tractor plugs, and build a growing, profitable business among tractor owners in your territory.

THE SILVEX COMPANY  
**BETHLEHEM PRODUCTS**  
 E. H. SCHWAB, President  
 BETHLEHEM, PA., U. S. A

*Bethlehem*  
**SPARK PLUGS**

3/4 inch long mica tractor plug Used as standard equipment on International Harvester Tractor and others.

# ALLIS-CHALMERS

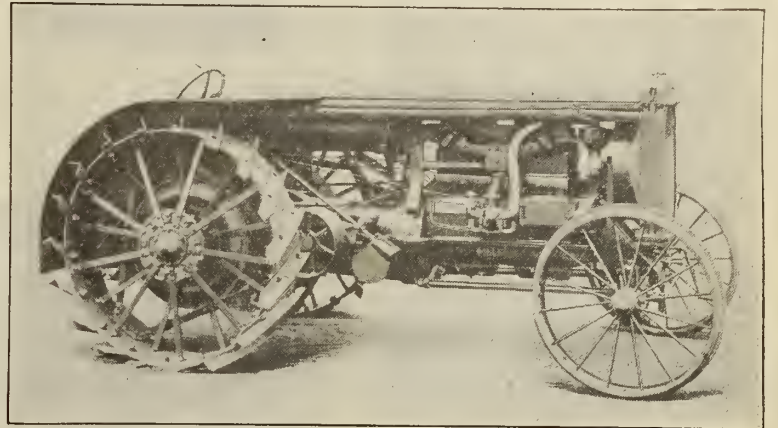

The 18-30 Tractor embodies the most modern engineering and construction. Officially proven a leader in the Tractor Field. Price complete, \$1,785.00 f.o.b. Factory.

With 1920 has dawned a new era in Canada.

Prosperity will reign again.

Have you investigated the money-making possibilities of the Allis-Chalmers Tractor Line?

DO IT NOW!

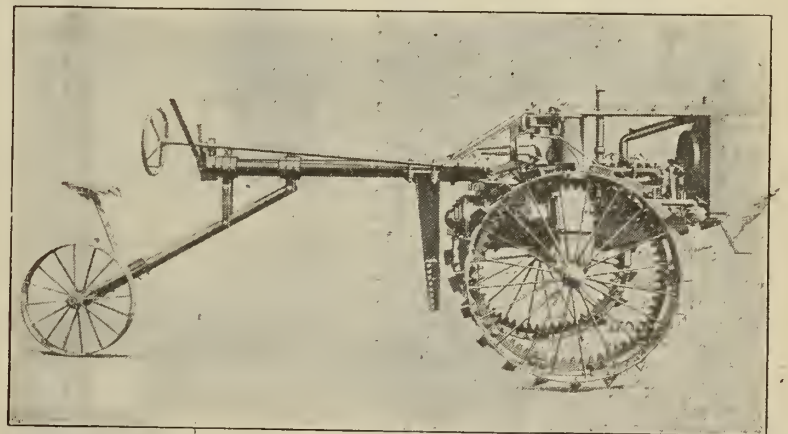

The 6-12 Tractor is readily attached to any implement the farmer may already have requiring four horses or less, and forms a real one-man outfit. 12 belt h.p. Price complete \$795.00, f.o.b. Factory.

**Canadian Allis-Chalmers, Limited**

Head Office: 212 King W. Toronto

## BIRDELL CLOVER HULLERS

Best for Thrashing, Hulling and Cleaning

Little Red or Common Clover Seed  
 Big English or Mammoth Clover Seed  
 Alsike Clover Seed  
 Sweet Clover Seed



THREE SIZES FOR CANADA

No. 2	Cylinders 27" x 32"	Capacity 3 to 5 bushels per hour,	Power Required 6 to 8 H. P.
No. 1	Cylinders 30" x 36"	Capacity 5 to 7 bushels per hour,	8 to 10 H. P.
No. 8	Cylinders 40" x 52"	Capacity 7 to 10 bushels per hour,	10 to 12 H. P.

WE HAVE A SIZE TO SUIT EVERY NEED

## ANN ARBOR HAY PRESSES

If in the market for a Hay Baler we can furnish in any size to meet your requirements. Write us or call and see us while in the city.

**Birdsell Manufacturing Co.**

Foot of George Street  
 Toronto, Canada



### RADIATOR COVER

THE Atlas Radiator and Combination Radiator and Hood Cover, manufactured by the Atlas Specialty Mfg. Co., 18 East Twenty-fourth Street, Chicago, are constructed with one-piece detachable curtain which may be used to cover either upper or lower half, right or left side of radiator front. The manufacturers claim the cover is especially desirable on cars where there is a lack of space between headlight brace and radiator as the curtain is detachable. While driving during extremely cold weather the lower half may be covered. Carburetor and manifold may be protected by adjusting the curtain to cover side on which they are located. The cover is attached to the car by means of metal clips. The hood cover is well reinforced at all places subject to excessive wear, and is fastened to the radiator by means of glove buttons, and is tailor finished. It is weatherproof and will not crack.



Radiator Cover.

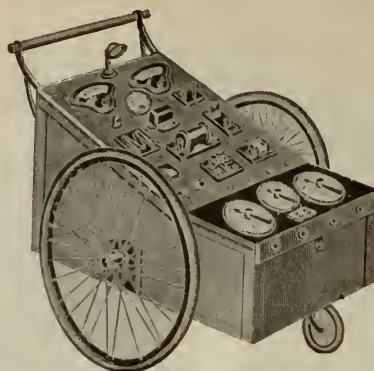

Niehoff Test-Kart.

### THE NORVELL INSIDE HOOD COVER

THE Norvell Inside Hood Cover is being marketed by the Missouri Insulating Co., St. Louis, Mo. It is a hood cover designed to fit underneath the hood of an automobile—out of sight and out of the way. The Norvell Inside Hood Cover is composed of a specially prepared fibre composition coated with a waterproof liquid making it resistant to weather conditions. It is applied to the louvre sections underneath the hood and does not interfere with the raising or lowering of the hood nor does it mar the beauty or appearance of the car.

The hood cover comes in two sections, which are made to adhere to the louvre sections by means of flexible metal clips that slip through the openings in the joints of the hood and which are bent into place with the fingers. It is built on the principle of retaining the heat from the engine in the hood chamber enabling the engine to respond quickly in cold weather.



Norvell Inside Hood Cover.

### FEDERAL CYLINDER—TEST GAUGE

THE Federal Products Corporation, Providence, R.I., has placed on the market an instrument for testing the cylinder vibrations of automobiles and trucks.

The gauge feelers of the Federal Cylinder Test Gauge are inserted in the cylinder. These bear at their inner ends, by means of spiral springs, against a cone cam, which is directly connected by a steel rod, running through an outer casing to a rack and spur movement operating the gauge dial. A lever is also attached to the steel rod by means of which the cone cam is lowered, thus permitting the feelers to recede sufficiently to be inserted in the cylinder. Once the feelers are inside the bore, pressure on the lever is withdrawn and the feelers are automatically released against the inner sides of the cylinder.

A centralizing support holds the apparatus in position. This support is placed at the mouth of the cylinder and has three fingers which bind firmly against the walls of the cylinder by a scroll and rack movement operated by a hand wheel.

The gauge body turns freely and slides in and out through the centralizing support, permitting the feelers to bear wherever desired on the inner cylinder walls.

The makers say the Gauge Dial, which is graduated in thousandths of an inch, can also be turned to any position on the same axis as the hand wheel, so that readings can be taken with the best possible light and the least effort.

In practice the feelers before insertion in the cylinder are set to a master gauge, while, at the same time, the face of the dial is turned until the hand points to zero. Then when the feelers are moved about in the cylinder all variations from the correct dimensions are indicated by a movement of the dial

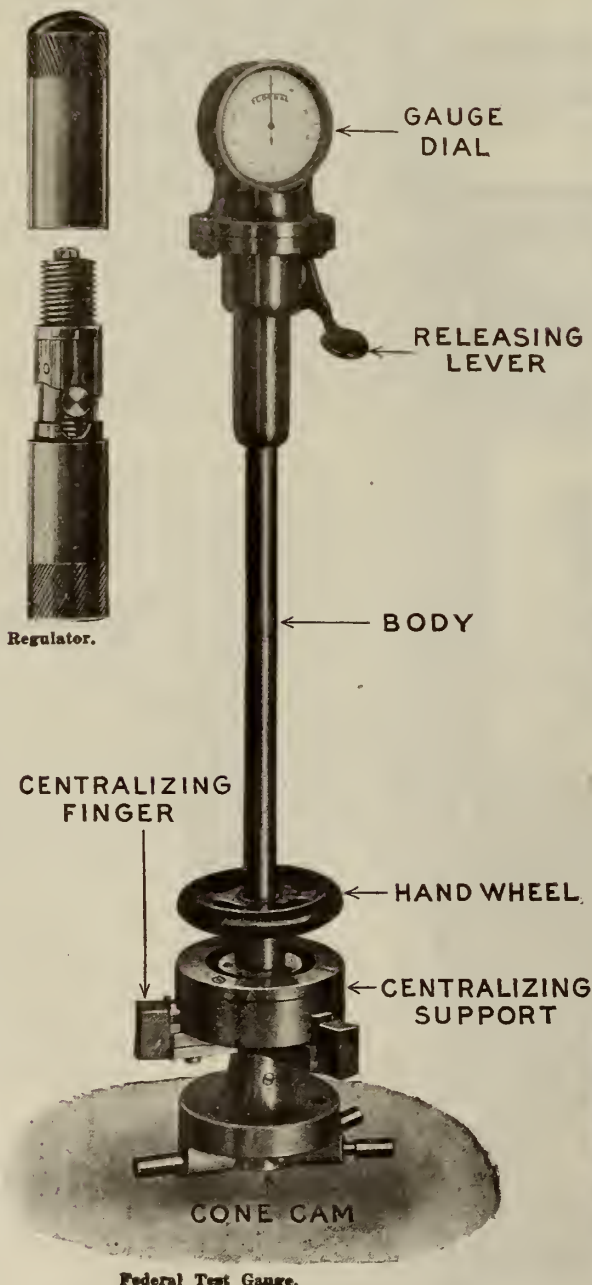

Federal Test Gauge.



Safetee Glass—weight test.



Safetee Glass—the weight test.



Niehoff Spark Tester

hand to either side of zero. Caps are furnished for the gauge feelers so that they can be set to fit any size of bore.

### NIEHOFF TEST-KART

THE Paul G. Niehoff Company of Chicago has placed on the market a new machine for locating all electrical trouble in connection with the electrical mechanism of an automobile, such as the ignition, starter, generator, battery, wiring relays, meters, etc. The makers claim their machine is a money-saver and a positive convenience to the public as it enables the repairman to determine the trouble and estimate the approximate cost while the motorist waits. The wagon is equipped with leads, ready for attaching to any part of the electrical system for locating shorts and grounds. Storage battery fits right in the wagon. All meters are special and of Western make. It is recommended for general automotive garage service stations.

### ROSE PUNCTURE PLUG

THIS is a device for repairing inner tube punctures. It consists of a pneumatic plug operated by a special tool. The makers say a perfect repair can be made in twenty seconds. It has been subjected to severe tests and has proved satisfactory. The manufacturers are the Rose Pneumatic Plug Co., 2133 Michigan Avenue, Chicago.



Rose Puncture Plug

### SAFETEE GLASS

THIS is a new glass for automobile windshields, windows, lamps, etc., manufactured by the Super-Glass Company, Philadelphia. The makers say it absolutely eliminates the possibility of accident from shattered flying glass. You can hit it with a hammer, and it will not crack, but it will not shatter, nor will any pieces fly. It is fifty per cent. stronger, and will stand more abuse than ordinary glass. When cracked it remains windproof and waterproof.

A machine gun bullet shot through this glass makes only a hole, as it would through steel the same thickness.

It consists of a sheet of Du Pont's best grade "Paralin," welded between two sheets of glass, at very high heat and tremendous pressure, by a patented process.

### PRESSURE REGULATOR

THE Automatic Safety Pressure Regulator manufactured by the Automatic Safety Tire Valve Corporation, 1765 Broadway, New York, insures tires against prematurely going to the junk man. The manufacturers claim that it is designed to do away with all guesswork in the matter of inflation.

The regulator consists of an adjustable spring mounted valve. This is screwed onto the existing valve without changing the latter in any way. The air supply is connected to the top of the device and when the pressure inside the tire reaches the point set on the adjusting collar the regulator whistles and all surplus air is emitted through a hole in the side. The regulating collar is notched so that it cannot accidentally slip out of adjustment.

### COMPRESSION SPARK TESTER

THE Niehoff Compression Spark Tester is an apparatus that enables one to make a test, and determine accurately, the status on any coil or magneto under conditions corresponding to the compression of the motor. It is an airtight metal chamber, provided with a standard spark plug, an air gauge and air valve, which fits any tire or bicycle pump. The spark can be readily seen through a lens constructed for that purpose. The makers, Paul Niehoff and Co., Chicago, state that its construction is very durable, and method of operation simple. There are three styles for single, four, and six-cylinder.



# Cletrac Closes Huge Quebec Contract

**T**REMENDOUS sales of Cletrac tractors in the Province of Quebec are expected within the next few years, according to an announcement made by Hon. J. E. Caron, Minister of Agriculture, who is also Cletrac distributor for the province. An Association Press despatch under date of December 19 says:

"The Provincial Government has entered the field as a competitor in the development of the motor industry, and has entered into a contract with a company across the border to supply tractors for the farmers at cut rates.

"The decision was arrived at on November 5 last, when a contract was entered into with the Cleveland Tractor Company to supply Cletrac tractors to farmers in the province at a special price of \$1,100 f.o.b. Cleveland, instead of the regular price of \$1,585, on condition that the orders for these machines are transmitted by the Minister of Agriculture, without any obligation on the part of the latter to buy any number whatsoever of the machines. The Cleveland Tractor Company undertakes to organize a service to put into operation the machines in question and for the sale and exchange of all parts, the cost of the delivery and demonstration of the tractors being paid by the company.

"The information given above was secured from the Minister of Agriculture, the Hon. J. E. Caron, in reply to a question put by C. E. Gault, on behalf of Mr. Sauve, yesterday afternoon.

"In reply to a question the Minister of Agriculture said it was true that he was the distributor of the Cletrac tractors for the Province of Quebec. He further stated that no tenders for the sale of tractors were requested from other companies, and he had no statistics on the number of companies that manufactured or sold tractors in the province. He added, in reply to a query as to why the Government had preferred the Cleveland company that it was because the tractor of the Cleveland company is one that is best adapted for the farms of the province."

Note.—The despatch is incorrect in stating that the contract is made with a "company across the border." It is with the Cleveland Tractor Co. of Canada.—Editor.

**I**T WAS stated in a report to the M. T. I. that the Cletrac company expected to sell 6,000 tractors in Quebec alone during the next three years, and in order to verify the terms of the contract W. G. Bell, managing director of the Cleveland Tractor Co. of Canada was requested to add any further information. Mr. Bell believes the future for tractors in Quebec province is very rosy, but does not commit himself to any statement as to numbers.

## Windsor

"There is very little information to give out in reference to the Quebec deal outside of that already announced by the Hon. J. E. Caron, Minister of Agriculture to the Associated Press.

"We have entered into a contract with the Department of Agriculture of



This is the man who "put across" the contract.

## Selling Tractors and Implements in the Winter

[By A. H. ALFSEN

**T**HE tractor and implement dealer during the winter should map out his campaign for the coming year. The tendency in the past has been to slacken off during the winter months, to take things easy and wait for spring, in the belief that winter sales were impossible, or, at least, hard to get. The progressive dealer has gotten away from that idea now and takes advantage of the winter to do his mapping out, and most aggressive work. He recognizes that, in the spring, when the farmer is getting ready for his season's work, there are only a few, a very few, precious days in which he can sell the farmer.

Time is money, whether in selling farm implements or doing any other thing that counts; the time to sell the farmer, especially in the big farm implements, is in the winter.

I always made it a practice to start my canvass for the next year's goods in October, and met with wonderful results. As an inducement for the farmer to take his machines early, I offered to deliver them free of charge. As my prospects were located from seven to twenty miles away from my place of business, I devised a scheme for securing cheap delivery of goods sold.

In that district, most of the farm produce in the winter was hauled into market on sleighs, so I got in touch with farmers from the various sections, and bargained with them to deliver machinery on their homeward journey at so much a load. I had it arranged so that no man would require to go out of his way to make a delivery. The result of this plan was: I got a cheap delivery—expenses amounting to less than 1 per cent.—and had all my machinery delivered during the winter. The men whom I had out on the road selling—usually two—did all the assembling as well,

the Province of Quebec, whereby they will distribute Cletrac tractors to the farmers through their large organization. We maintain control and handling of the service. The Department of Agriculture have some 1,200 agronomists in the Province of Quebec, which is an average of approximately one to each parish. It is through these agronomists that we expect to reach the home of every farmer, which gives us a Cletrac selling force of 1,200 salesmen in the Province of Quebec. These men will be directed and instructed by the Department along the same lines as we instructed our own salesmen. A service station will be appointed in each parish to take care of the service and sale of parts. The exact number of tractors that will be sold under this plan is more or less guesswork at the present time, but we anticipate tremendous sales in the next three years."

and had machinery ready in ample time for the commencement of the spring work.

The first season I adopted this plan I sold more than twice as much as my competitor; and while he had considerable trouble in getting his machines set up in time for the work, I experienced none whatever.

**D**URING the winter months, the farmer has less to do than at any other time of the year, and is always willing to talk. He is eager for information, and likes to discuss new things. In discussing the tractor, I show him the advantage of buying in the winter and having his machine at hand when the spring season opens, and how it can be used for plowing, when the condition of the soil is such that horses cannot be used.

If you can't close at first with the farmer, it is a good plan to make a definite date with him. In my experience I have found that 90 per cent. of the farmers I made a date with were eagerly waiting on my visit, and after further discussion almost invariably made a sale.

The dealer should see to it that he has on view in his showroom a more or less complete tractor outfit, illustrating to the visitor its uses in the field, and in connection with the various implements.

A vigorous advertising campaign in the local papers at this time, coupled with personal letters showered among the farmers, will go a long way to prevent a dull season, and prepare the ground for next year's sales.

## GRAY-DORT DEALERS IN CONVENTION

**S**EVENTY Gray-Dort automobile dealers, from Toronto and Hamilton, on Dec. 5, were the guests at a conference and banquet given by the Gray-Dort Motors, Limited, at the works in Chatham. W. E. Finnegan, general sales manager, was in charge of the program. The principal business was discussing the campaign for 1920. Addresses were given by R. A. Baker, of Toronto, and K. P. Albridge, chief engineer for the Gray-Dort Company, Chatham. At the banquet, Wm. Gray, vice-president of the company, gave an address of welcome and encouragement to the dealers. As a result of the conference, the company received an order, through the dealers, for 48 carloads of cars for immediate shipping.

The Gray-Dort Motors has adopted the Industrial Council system for amicably settling disputes between employer and employees. A system has also been adopted whereby every employee will have his life insured at the expense of the company. The corporation has decided to grant a bonus of 5 per cent. for punctuality and regular attendance, and plans are well on the way for the erection of a club house for members of the staff and employees—the expense of which will be borne by the management.

## "M" HAPPY FARMER

**A** NEW Happy Farmer tractor, Model "M," will be placed on the Canadian market early in 1920, and distributed by the Renfrew Machinery Co. It will be a light tractor, and for 1920 the allotment for Canada will not amount to more than 25, in all likelihood, as the production for the first year will not be very large.

A Model "M" is scheduled for exhibition at Renfrew during the Renfrew Machinery Co.'s convention there January 6-8. Regarding this new model, the distributors write:

"It is handy, light, has a draw-bar pull of 1,000 lbs.—the working load of four or five horses. On the belt it develops 12 h.p., sufficient to operate a small ensilage cutter, corn cutter, wood saws and similar machinery. It also does all light field work done by horses; has a 30 in. clearance and will draw either horse-drawn or tractor implements. It can be used for cultivating, pulling plows, discs and harrows, hauling the manure spreader, drill and seeder, mower and hay rake. In fact, it will haul any farm implement on which horses are used at the present time.

"This tractor has the line drive attachment and the farmer is perfectly comfortable on his corn cutter, for instance, using his tractor as he would a team of horses. What is particularly attractive about this little tractor is that it will reach the small farmer—the man with the hundred acres—on account of its price, which will be reasonable; and secondly, it is not the type of machine that has any particular parts to go wrong, and it will therefore need very little looking after."

## B T VANCOUVER OFFICE

**A.** K. FREEBORN, who has been handling Beatty Bros., Fergus, Ontario, business in British Columbia for some years, has been appointed manager of the new branch which this organization has just opened in Vancouver. The office is located at Block 900, Granville street. Mr. Freeborn is particularly well known to the B. C. trade.



A. K. Freeborn.



Here is a line-up of Cletracs outside the store of the aggressive Omega Machinery Co., St. Hyacinthe, Quebec.



"Pressure Proof—Competition Proof"



## Pressure Proof Piston Rings

LINE THEM UP TO-DAY!

See that your customer's piston ring needs are met with the one mechanically correct piston ring.

Sell Pressure Proof rings. Their exclusive features will find ready buyers and Pressure Proof performance will create a steady, increasing demand.

A nice profit to you results from the first sale. Order your shipment now!

*A booklet telling the Pressure Proof story will be sent you free on request. Ask us to quote you trade discounts.*

### PRESSURE PROOF RINGS, LTD.

SHERBROOKE, QUE.

## Hindview AUTO MIRRORS



Style A



Style D—for Motor Trucks



Style F  
for Front Fenders



C Bracket  
for Closed Bodies



Style A—Long

The "Hindview" Auto Mirror prevents accidents by enabling the driver to keep an eye on the rear traffic without losing sight of the road ahead. Our Ball Joint allows immediate adjustment to any desired angle without the use of any tool.

Substantially made—nicely finished—has five inch plain, or lens, plate glass mirror. The lens mirror increases the field of vision about 50 per cent. without distorting the view. Note large, firm clamp for attaching to windshield.

Write for our folder showing complete line  
Agents, Jobbers, Write for our Proposition



Superior Quality

Prompt Deliveries

PRESSED METAL PARTS, LIGHT AND MEDIUM WEIGHT STAMPINGS

Our complete plant, superior equipment and efficient organization are at your service. You will insure satisfactory results by letting us make your stampings. Motor, axle, transmission and clutch stampings. Write to-day enclosing blue prints or samples for estimates and our catalog.

**KALES STAMPING COMPANY**

446 West Lafayette Blvd.

Detroit, Michigan

Canadian Representative: Donald F. Johnston, 146 Bleury St., Montreal, Que.; Yonge and Dundonald Sts., Toronto, Ont.; 612 Portage Ave., Winnipeg, Man.

NEWS — OF THE TRADE  
FOR THE TRADE

### ONTARIO

**DESERONTO.**—The new Quinte Garage, proprietor W. N. Myles, is open for business.

**TORONTO.**—The Puncture Proof Tire Company, Limited, has been voluntarily wound up.

**BADEN.**—N. M. Steinman, furniture dealer, has taken on the agency for Maxwell cars.

**TORONTO.**—The Ontario Motor League will hold its annual meeting in Toronto, Wednesday, Jan. 21.

**ALLISTON.**—H. Gibson, of Barrie, has bought A. E. Stephens' Garage and will handle the Chevrolet car.

**COOKSTOWN.**—H. T. Rankin, owner of Rankin's Garage, is installing a steam heating system in his garage.

**CHATHAM.**—A new La France combination truck has been purchased by the Fire Department at a cost of \$14,500.

**WOODSTOCK.**—The Central Garage opened at 526-532 Dundas Street, has many new features, including a rest room for ladies. It is 100 x 67 feet.

**LONDON.**—Wilfrid Hodgins has been elected president, and F. D. McLaughlin, secretary, of the London Auto and Accessory Dealers' Section of the R. M. A.

**PARKHILL.**—A new garage, 50 x 150 feet, has been opened by A. D. Calvert and C. Rawson. They have the agency for Ford cars. Both men have returned from overseas.

**LONDON.**—The F. E. Partridge Tire and Rubber Co., Guelph, entertained a number of members of the trade at a business dinner, December 5, at the Tecumseh Hotel.

**TORONTO.**—The Chief of Police has intimated that time for parking automobiles at curbs in the downtown section of the city will have to be limited to five or ten minutes.

**NEWMARKET.**—Hamilton Bros. are fitting up a new garage on the corner of Main and Water streets. They have the Chevrolet agency and will carry a line of accessories. The garage will be ready in the spring.

**WOODSTOCK.**—F. Craig has been elected president, and W. Berlangette secretary of the Woodstock and Oxford County branch of the auto dealers section of the R. M. A. of Ontario.

**CHATHAM.**—The Gray-Dort Motor Co. entertained about 70 of their dealers from Montreal and Ottawa at a banquet recently. Addresses were given the keynote of which was "co-operation and 'pep'."

**GODERICH.**—The citizens of Goderich will be asked to vote on a by-law in January, to grant exemption of taxes, except school taxes, to the Dominion Machine Company, for a further period of ten years.

**TORONTO.**—G. E. Gooderham and Co. are constructing a large portion to their motor car show-rooms and garage on the property recently purchased by them from Fred H. Ross and Co., in Sheppard Street.

**STRATFORD.**—A new business, Keil's Tire Vulcanizing and Welding Plant, has been opened up in Ontario Street. It has all latest equipment and will handle vulcanizing, welding, repairing, tires and accessories.

**TORONTO.**—The office staff of the Willys-Overland Co., presented E. A. Olson, secretary-treasurer, with a gold watch on the occasion of his leaving the company to take up a position with the Continental Guarantee Co., of New York.

**TORONTO.**—The Commerce Motor Car Company of Detroit is expected to

locate in Toronto, and is looking for a factory site for the manufacture of Commerce trucks. Receipt of a large British order is said to be the incentive for this move.

**TAVISTOCK.**—A new garage has been opened by M. McDermott and Son. It is 40 x 80 feet and has modern improvements. The new concern has the agency for Chevrolet cars, and handle blacksmithing and repairing, tires, tubes and accessories.

**TORONTO.**—Thieves made a fine haul of aluminum castings and auto fittings recently, at the Toronto Automobile Wrecking Company, 179 Queen Street West. The loss amounted to upwards of \$500; more than 1,500 pounds of aluminum castings alone were taken.

**LONDON.**—J. Gavnor, motor truck inspector for the International Harvester Company of Canada, London branch, had the misfortune recently to accidentally scald his face near his right eye. Although it was quite painful, Mr. Gavnor was able to remain "on the job."

**WINDSOR.**—The Ford Motor Co. of Canada has purchased the properties of the Dominion Stamping Co., at a cost of approximately \$450,000. The manufacture of fenders, sheet metal work and other auto accessories made by the stamping company will now be manufactured by the Ford Company.

**ST. CATHARINES.**—The Board of Health has decided to purchase a motor ambulance. The order has been placed with the Wells Garage Co. The ambulance will be a 144-inch wheel base, six cylinder McLaughlin-Buick chassis. The body will be built in the city by R. Hamil. The total cost is expected to be \$3,150.00.

**WOODSTOCK.**—The Rudd Sales and Feed Stables, on Graham Street, are being remodelled into a modern automobile garage and service station. The new garage will be ready shortly, and is being equipped to handle repairs, accessories, tires, oils, gasoline, etc. There will also be ample space for storage during the winter.

**WOODSTOCK.**—A fire, started by a spark, which resulted when a mechanic touched two electrically charged wires on a car he was repairing, caused considerable damage to the Oxford Garage, Dundas Street. A number of automobiles were destroyed and a considerable amount of stock. The damage is estimated at \$20,000.

**HAMILTON.**—Messrs. Walker-Vallance, Limited, 131 King Street West, have been made direct factory representatives of the Dodge Bros. They also handle the Hudson Super-Six and the Republic trucks. Messrs. Walker-Vallance, Limited, have found it necessary to enlarge their show-room owing to increasing business.

**BRANTFORD.**—Motor Trucks, Limited, is asking the civic authorities for a refund of \$3,861 business tax, paid for 1918, during which year the plant was closed up. The civic authorities contend that the tax was paid by the United States Government, but the company declare that that sum was deducted from their payment when the final settlement was made.

**HAMILTON.**—G. H. Long, and D. L. McIntyre, of Hamilton, have invented a small motor tractor which they believe will have a powerful effect on the tractor industry. They have taken a Ford truck as the foundation for their invention, using the Ford engine and the front end of the Ford truck, a chassis and traction connection, and have constructed a tractor of wonderful pulling powers. In a test it proved highly satisfactory.





**YOU** get a bigger yield on every acre when you prepare the seed bed with

12 H. P. on Draw-Bar

25 H. P. on Belt Pulley

**THE HUBER Light Four**

Draws three bottoms

Turns an acre an hour

"The Tractor Dependable"

Plows more deeply. Discs and harrows more thoroughly. And it gets the work done quickly when the soil is just right. The increased yield pays back the cost of the tractor in a little while.

Because of its simple power-saving design, and the nice balance between power and weight, the Huber Light Four gives you more work to the gallon of fuel used.

All spur-gear-drive to the draw-bar converts the highest possible portion of the power developed by the motor into useful work. High test alloy steel makes the tractor light—it will not pack plowed ground; center draft, conserves power; high wheels roll easier and provide greater traction grip.

Huber simplicity is the mark of experience in tractor building. It explains the Huber reputation: "It always keeps running"—and farmers above everything else must have reliability. *Write now for "The Foundation of Tractor Reliability."*

**The Barkley Tractor & Separator Co.**  
Edmonton, Alta.

**The Huber Manufacturing Co.**  
Brandon, Man.

Weight 5,000 pounds; pulls three 14" bottom plows; Waukesha, four-cylinder motor; Perfex Radiator; Hyatt Roller Bearings; burns gasoline, kerosene or distillate; center draft; two speeds, 2½ and 4 miles per hour.

The Huber Jr. Thresher and the Huber Light Four are made by the Huber Manufacturing Co., Marion, Ohio, U. S. A.



**Begin The New Year Right!**

Much of a dealer's success lies in his ability to gain and to retain his customers' confidence. You have an excellent opportunity to foster this confidence by selling the dependable

**FLEURY Farm Implements**

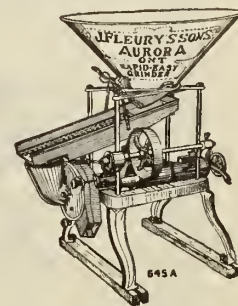

The farmer naturally relies upon the dealer to a large extent for advice. Be careful, therefore, to advocate the use of only such goods as you can be sure will prove satisfactory.

**SELL FLEURY IMPLEMENTS**

**THE BEST THAT SKILL AND EXPERIENCE CAN PRODUCE**

**OUR RECORD OF SIXTY YEARS IS YOUR BEST PROTECTION**

Send your application now for Fleury Contract for 1920.

**J. FLEURY'S SONS, Aurora, Ont.**

**Lubricants of Quality**

A LITTLE GOES A LONG WAY

**HARRIS OILS AND GREASES**

AND EVERY DROP COUNTS

**HARRIS TRACTOR CYLINDER OILS**

MADE IN FOUR GRADES

**HEAVY, EXTRA HEAVY, SPECIAL AND EXCELLO**

from Premium Pennsylvania Crude by a careful process to meet the exacting conditions of the Tractor Motor---HARRIS OILS have a high fire test and are very viscous. One of the four grades above listed will properly lubricate any Tractor---HARRIS OILS have been on the market for over 35 years and have won the distinction of being



**AMERICA'S LEADING LUBRICANTS**

*Write for Prices and Booklet*

**A. W. Harris Oil Co.**  
326-328 South Water St.  
PROVIDENCE, R.I.



## THE BEST BUMPERS OBTAINABLE



"KABEE"  
SPRING ARM CHANNEL  
BUMPER

"LYON"  
RESILIENT BAR  
BUMPER

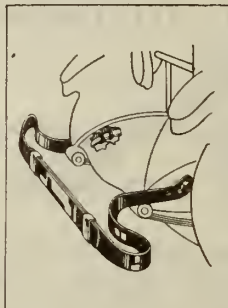

DURABLE BRILLIANT FINISH  
PATENTED "HOOKBOLT" ATTACHMENT  
FITS 90% OF STANDARD CARS  
OBTAINABLE FROM JOBBERS & DEALERS  
CATALOGUE ON REQUEST

**KINZINGER BRUCE & CO. LTD.**  
NIAGARA-FALLS, CANADA  
SOLE MANUFACTURERS UNDER  
LYON CANADIAN PATENTS.

# Mr. Dealer! IF

Price  
Quality of Material  
Workmanship  
Close Skimming  
and  
Easy Turning

are considered by your  
customers in buying a  
Cream Separator, then  
we claim that the

## Sanitary King

is the best buy in Can-  
ada to-day. Write for  
prices and terms.

## King Separator Works of Canada

Limited  
Bridgeburg or Whitby, Ont.



SAYS THE MASTER MECH-  
ANIC: The Greb Automatic Grip  
Puller is a One-Man Puller —  
Quick-acting, strong and simple  
in the extreme. May be locked in  
any desired position. A combina-  
tion of two or three arms. Heavy  
Duty Size capacity 1" to 1 1/2"  
Junior Size capacity 1" to 7/8". Two  
sets of jaws furnished with each  
size.  
TEN DAYS' TRIAL — If your  
dealer or jobber does not have  
them we will send you one. Try  
it ten days. If not satisfactory,  
return to us and we will refund your money. We also  
make the GREB RIM TOOL.

THE GREB COMPANY, 319 State St., BOSTON

### NEW SHARPLES MANAGER

THE Sharples Separator Company  
announces the appointment of W.  
H. Jensen as manager of the Sharples  
branch office at San Francisco, Cal.  
Mr. Jensen first joined the Sharples  
organization, in 1910, as a traveling  
salesman on the Portland territory,  
and in 1914 was made manager of the  
branch office at Portland Ore.

### WESTERN CANADA DAIRY SHOW

The Western Canada Dairy Cattle  
Show will be held in Winnipeg from  
February 16 to 22. The auditorium of  
the Industrial Bureau has been secured;  
and as several alterations have been  
made, giving increased space, the pro-  
moters are looking forward to a record  
show. There will be many exhibitors  
of household and dairy equipment.

### ROLLER-SMITH CHANGE

NEW YORK. — The Roller-Smith  
Company, 233 Broadway, New York  
City, makers of electrical instruments,  
meters and circuit breakers, announces  
the appointment of G. Linnstrom as  
works manager of its plant at Bethle-  
hem, Pa.

### SOME CHRISTMAS GIFT

TORONTO.—A motorist walked into  
the Automobile and Supply Co., Ltd.,  
around Christmas time and purchased  
three Hupmobiles for Christmas gifts.

## Dairy and Household Supplies

### GET WIFE'S GOOD WILL

FRED. M. CLOW, implement deal-  
er of Kingston, has a few points  
to make in regard to selling  
household and dairy labor-saving de-  
vices, which are of interest to dealers.  
He says the best way to get a farmer  
interested is to first of all get the good-  
will of his wife.

"Women, for some reason or other,"  
says Mr. Clow, "look on most imple-  
ment dealers with suspicion. Therefore,  
it is up to the dealer to win her over to  
his side. When he accomplishes this  
his task of selling the farmer becomes a  
comparatively easy matter."

Mr. Clow proceeds to do this by put-  
ting a washing machine on his car, and  
taking it out to the farm for a demon-  
stration. He shows the machine in op-  
eration, and even does a little washing  
himself. He enlarges on the folly of  
the old method of washing, both from  
an economic and hygienic standpoint;  
and, as a rule, he seldom fails to inter-  
est the "gude wife." When she sees a  
machine that can—without much effort  
on anybody's part—do a large washing  
in an hour or so, which usually takes  
five hours of her time, she is not hard  
to convince.

After selling a washing machine—you  
see Mr. Clow takes it as a foregone  
conclusion that a machine will be sold—  
an order for a separator or a milking  
machine often follows.

### SELLING LIGHT PLANTS

THE dealer who hasn't yet taken on  
the farm lighting plant should  
seriously consider doing so now. The  
farmers all over the country are becom-  
ing alive to the advantages of an elec-  
tric generating system. Their sons and  
daughters go to the cities to get an  
education, and when they come home  
for the holidays, the farmers feel the  
necessity of providing for them as  
many of the modern conveniences they  
are accustomed to in the cities as pos-  
sible.

Once a lighting system is installed,  
the labor-saving devices that can be  
used with it on the farm, and in the  
household are without number. It is  
one of the most useful systems on the  
farm to-day. It eliminates the danger  
of fire from overturned lamps and  
lanterns, and reduces considerably the  
fire insurance rate. The light is al-  
ways ready; and the time, formerly  
used for cleaning and trimming the oil  
lamps—to say nothing of the constant  
watching and anxiety lest they fall, or  
through the neglect of someone, creep  
up and explode—can be used to better  
purpose around the ever busy farm and  
household.

Besides providing a better light, the  
generator can be used in conjunction  
with a pump for providing a full water  
supply, always ready for instant use.  
The dealer has some of his best argu-  
ments right there.

The advantages of a good water sup-  
ply in the house are manifold. The  
sewage problem, always a serious trou-  
ble on the farm, is done away with; and  
the luxury of a real bathroom is made  
possible. The separator, milking ma-  
chine, washing machine, etc., can all be  
operated by the electric motor.

The arguments in favor of the light-  
ing plant are numerous, and the live  
dealer should have little difficulty in  
convincing his prospects and making  
farm lighting a profitable part of his  
business. It can be sold in any season  
and installed anywhere. It is light  
enough so that it can be put in a car  
and taken to the farm—the proper  
place—for a demonstration. In the  
winter time, when business is not so  
pressing, the dealer can use his time to

advantage and profit by handling this  
live line.

### EMPIRE OFFICES MOVED

The Empire Cream Separator Com-  
pany has found it necessary, owing  
to increasing business, to secure more  
space and additional facilities for  
both the factory and advertising or-  
ganization. It has been decided to re-  
move all executive, sales, advertising,  
etc., to 150 Nassau street, New York  
City. The manufacturing plant will  
remain at Bloomfield, N.J., and will  
absorb all the space formerly occupied  
by the general offices.

H. A. McArthur, who was for sev-  
eral years Canadian director of the  
Empire Co., and is now assistant gen-  
eral manager of the parent company,  
paid a brief visit to the Canadian of-  
fice a few days ago. He reports 1919  
as a very good year for his organiza-  
tion, and looks forward to 1920 as one  
with unprecedented opportunities.  
When Mr. McArthur first took charge  
of the Canadian Empire office, milk-  
ing machines were not the recognized  
success and necessity they are to-day.  
Prior to this he spent a great many  
years in the implement game, running  
his own fine business at Sussex, New  
Brunswick, so that he is in a good  
position to know the dairy business  
and the implement man's problems  
thoroughly.

### ESSEX CO OFFICERS

ESSEX.—The following officers have  
been elected by stockholders of the Es-  
sex Tractor Company: President, L. F.  
Bedal; Vice-President, R. D. Potter;  
Secretary-Treasurer, J. F. Taylor; As-  
sistant Secretary, R. T. Drope; Direc-  
tors, L. P. Wigle, R. F. Taylor, James  
Jenkins, P. G. Ludwig. The company  
has decided to put on a stock issue of  
\$50,000, in order to go more extensively  
into the manufacture of tractors and  
trucks. An order for 500 tractors and  
an equal number of trucks for shipment  
to British West Indies has been re-  
ceived.

### THOS. FINDLEY'S GIFT

TORONTO.—Thomas Findley, man-  
ager of the Massey-Harris Company,  
was the recipient on Christmas morning  
of an illuminated Christmas address to  
which were attached the signatures of  
more than 4,000 employees in the Tor-  
onto, Weston, Brantford and Woodstock  
factories of the company. Mr. Findley,  
who is recovering after a period of ill-  
health, highly appreciated the employ-  
ees' expression of feeling.

### NEW B. & D. CATALOGUE

The Black and Decker Mfg. Co.,  
Baltimore, Md., has published a new  
catalogue describing their various elec-  
tric tools. The catalogue is printed on  
coated book-paper and beautifully illus-  
trated with photographs. The tools are  
described in detail and their functions  
explained. There are also photographs  
of the B. and D. plant at Towson, Md.,  
and the Baltimore plant and general  
offices.

FORD.—The Ford Motor Co. has  
purchased the properties of the Domin-  
ion Forge and Stamping Co., at a figure  
stated to be about \$750,000. The newly  
acquired plant will be used for the man-  
ufacture of finished parts such as fend-  
ers and frames. The services of the  
forging company employees will be re-  
tained by the Ford company at the  
same rating.



# DE LAVAL

## Dependability

The DE LAVAL Cream Separator is a dependable skimmer. With ordinary care it will keep its remarkably close-skimming qualities for a lifetime.

The DE LAVAL capacity rating is dependable. Each size exceeds its advertised capacity under ordinary, and even under unfavorable, farm conditions.

The De Laval Company is dependable---the oldest and largest cream separator manufacturers in the world.

The DE LAVAL Agency Contract can be depended on to return more and easier separator profits than any other contract.

There is no better time than right now to send in an application for a De Laval contract. There is more profitable cream separator business with the De Laval than with any other separator.



## The De Laval Company, Ltd.

*Largest Manufacturers of  
Dairy Supplies in Canada*

Montreal    Peterboro    Winnipeg    Vancouver

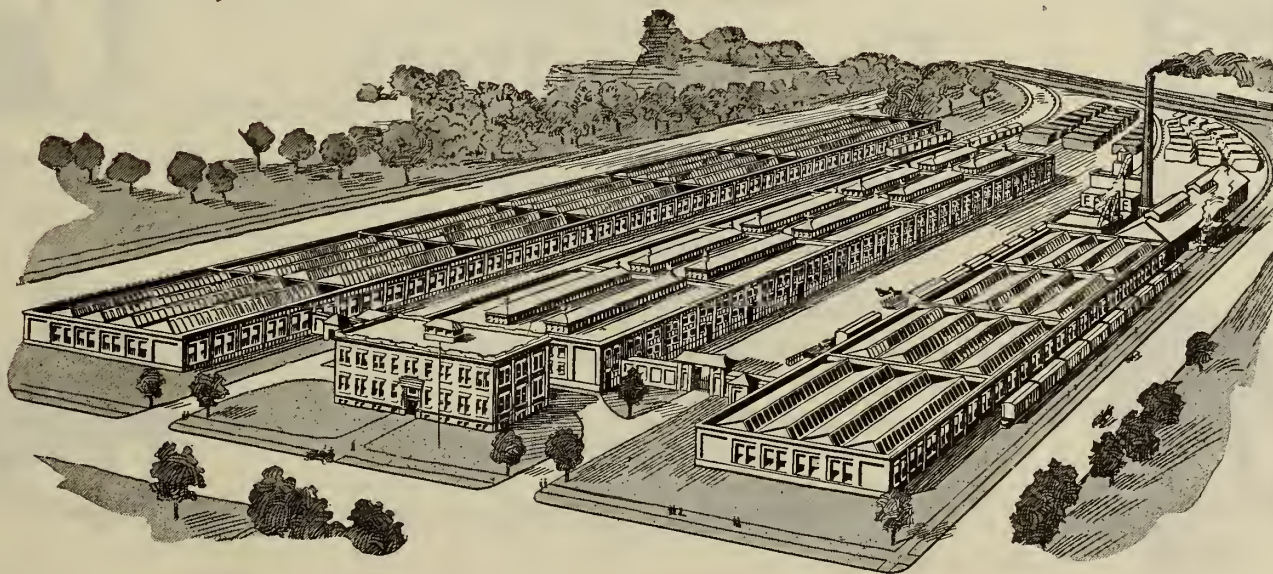



# The Ford Steering Control Sells Easily and Quickly:

## A Real Money Maker

With this steering appliance you can absolutely derive the same pleasure and safety in driving a Ford, as you experience in the highest priced cars

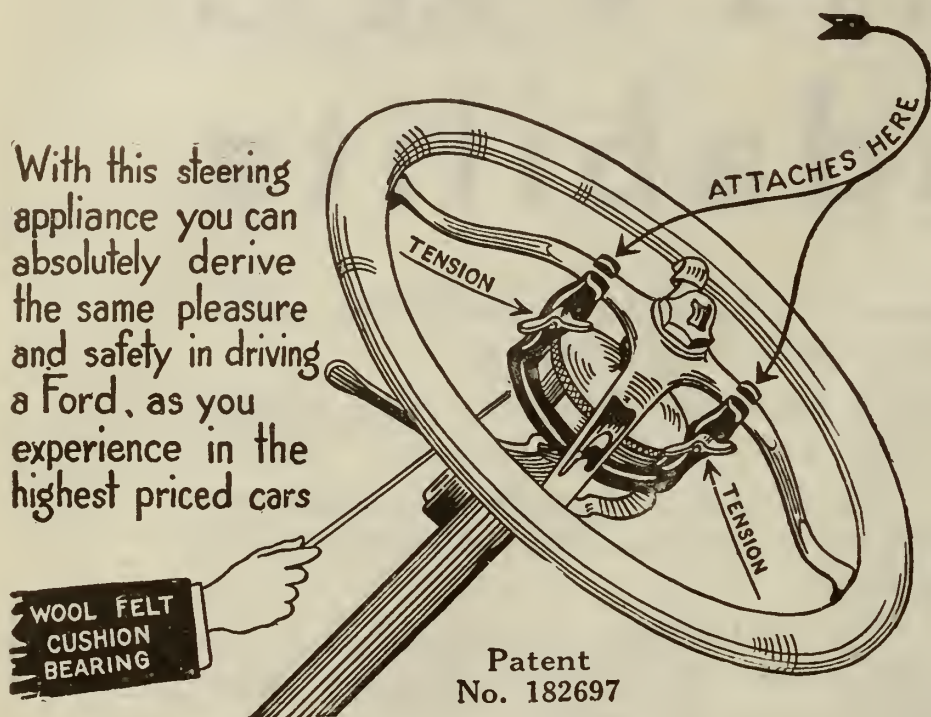

Patent  
No. 182697

Every Ford owner needs this device. A short demonstration clinches the sale. Sold on a "Drive it for TEN DAYS and if dissatisfied get your money back" guarantee. You can easily sell 9 out of 10 owners in your locality. The price \$3.75 (retail) is right.

Relieves all the strain of gripping the wheel. Saves tires by eliminating the quiver of front wheels. Minimizes the danger of swerving on rough roads. Guides the car in a straight line. Practically does away with cold hands in winter caused by gripping the wheel tightly.

Drop us a line for agency proposition and full particulars of terms and prices.

McKenzie, Crews & Company, Richmond Bldg., Toronto, Ont.

# More Business for YOU

Every farmer in your territory who feeds stock is a prospect for the dealer handling the

## Peter Hamilton Hand and Power Feed Cutters



No. 6 STRAW CUTTER  
Hand or Power  
The Dandiest, Handiest Cutter Built.

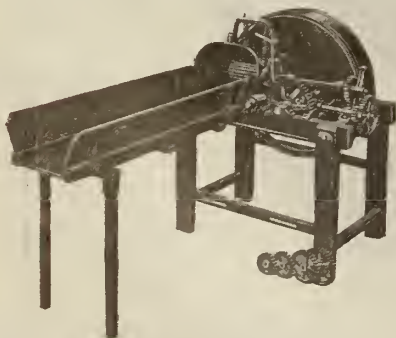

No. 7 STRAW CUTTER  
Twelve-inch Opening  
A Large Machine With Great Capacity

These cutters are appreciated on sight—they practically sell themselves. They will produce profitable business for you right now when other lines have slackened off. A little pushing of Hamilton Feed Cutters will start you off and build up sales for gas engines and other lines. We'll furnish you circulars for distribution on request if you will show Hamilton cutters and talk them up.

Made in all sizes, from hand machines to the power-run machines for the big stock raisers.

You can rely on Peter Hamilton goods—they make you friends. Write us to-day. Territories open for live dealers.

**The Peter Hamilton Co., Limited**  
*Makers of Agricultural Implements*  
PETERBORO ONTARIO



No. 3 PULPER  
The Cleanest Cutting and Easiest  
Driven Pulper Manufactured

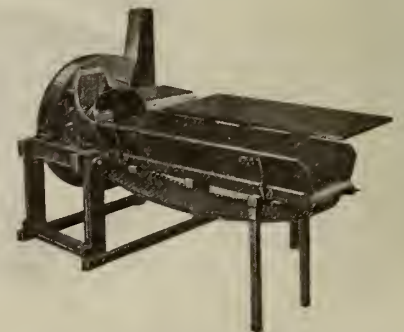

No. 7 BLOWER CUTTER  
Extraordinarily Good for Straw  
Cutting.  
We Also Build Mounted Blowers



# A special lubricating oil that makes separators run more smoothly and last longer

The Sharples Separator Company, the pioneer and largest manufacturer of separators, has made and put on the market a special oil for separators.

This oil has been perfected after many tests in the Sharples factory---first to make a separator run faster and better, and second, to keep the separator in a uniformly good condition. Fifty per cent of the break-downs in all separators is due to the use of the wrong oil. The high speed which a separator attains requires

## SHARPLES SEPARATOR OIL

As a dealer, you should feature and sell Sharples Separator Oil because of the large profit it pays and because every owner of a separator, emulsifier or clarifier is a logical prospect. The field is *wide open*.

The strong, handsomely lithographed container is an advertisement in itself. Display it on shelf or showcase. It will attract attention and bring sales. Arrange now for an advertising display of Sharples Separator Oil.

Write today for full particulars, prices and selling plan.

*Sharples Separator Oil comes in quart and gallon cans.*

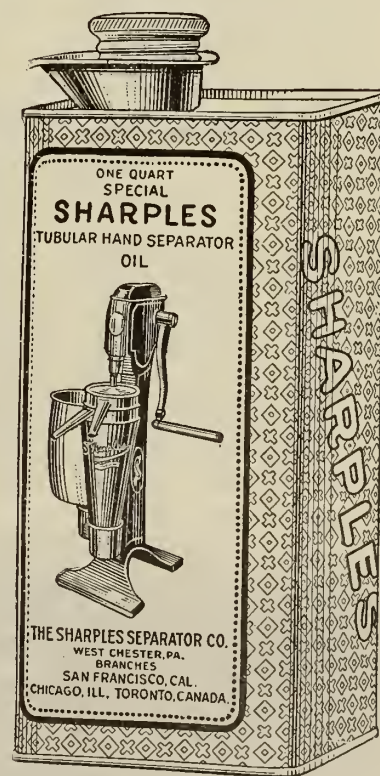

P-85

**The Sharples Separator Company,** Toronto, Ont.  
Regina, Sask.

THE LOUNSBURY CO.  
Newcastle, N. B.

Distributors through all their branches  
"Over 2,425,000 Sharples Separators in Daily Use" L. CLARK & SON  
Fredericton, N. B.



### PETITION FOR SERVICE SCHOOL

THE tractor enthusiasts of Plains, Kansas, didn't know whether they were on the Avery Company's schedule of Service Schools or not. In order to be sure that they were going to have one they made up a petition to the Avery Company, Wichita, Kansas, as follows:

"We, the undersigned tractor owners, operators of tractors, or tractor prospects, do hereby ask that the Avery Company hold a tractor school in Plains some time this winter.

"We do hereby promise that it is our intention to attend the school, if possible, to do so and to do all in our power to make it a success and to learn all that is possible for us to in the time that the school is here, in the operation, care and repair of tractors and their appliances."

Then follows the list of forty-three tractor enthusiasts, among whom are thirty owners; the operators number ten, while there are three prospects. Since a good attendance is assured, the Avery Company have granted the request.

### ADVANCE-RUMELY CONVENTION

ADVANCE-RUMELY'S branch managers from the United States and Canada gathered in LaPorte, Indiana, recently for their annual convention at the big plant. More than a week was spent in renewing friendships, and discussing the company's business and future plans. A trip through the plant was made. The convention closed with a banquet and entertainment at LaPorte, and a trip to Battle Creek, Michigan, to visit the Advance-Rumely factory there, where a farewell dinner was served. The Canadian dealers who attended were: C. W. McDonald, Saskatoon; P. Arnot, Regina; and M. J. Carrothers, Winnipeg.

### NEW GARAGE

SECORD AND HOWIE, Ford dealers, Dundas Street, Toronto, have completed the erection of their new building. The building is fire-proof and has a frontage of 66 feet by 110 feet deep. It has all the latest and up-to-date improvements. The showroom and offices, fitted up with a complete accessory department, occupy a space of 32 x 66 feet. There will be a service department with a floor space of 45 x 66 feet. The firm intend to build another storey, where all repair work and storage will be taken care of.

### AVERY CREATES OWN POWER

DUE to the existing shortage of fuel, the executives of the Avery Company, Peoria, Ill., faced with the alternative of closing down the plant or furnishing their own power, got out of the dilemma in a novel way. At the suggestion of Mr. Brandon, the mechanical engineer, they decided to further develop the motor tests at Plant No. 2 and tractor tests at Plant No. 1, in

order to furnish sufficient power to run the plant. The result was the company ran practically at full capacity during the coal shortage.

### SANAGAN PROMOTED

CLAUDE SANAGAN, a well-known Canadian newspaperman, for many years with the Toronto *Globe*, and who recently joined the staff of Willys-Over-

partments of the Russell Motor Car Co., Ltd. Major Birchard is a graduate of Toronto University.

### QUEER AUTO SMASH

BY one of the most curious of the many accidents that have happened on the Toronto-Hamilton highway a brand new car en route from the Ontario factory to a local dealer had its

## LAOCOON

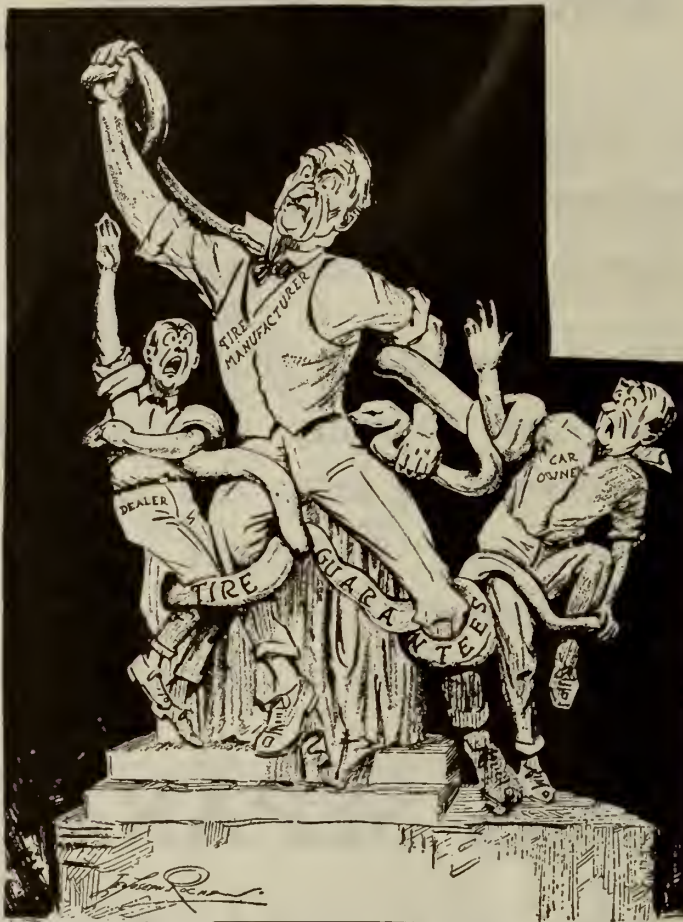

Like the priest Laocoön and his sons, portrayed in a famous sculptural group, in the coils of serpents sent by a goddess whose enmity they had incurred, tire manufacturers, dealers and users are in the grip of the mileage guarantee evil. Why not break the coils?

—“Motor World.”

land, West Toronto, has been promoted to the position of advertising manager.

### MAJOR BIRCHARD WITH REPUBLIC CO.

MAJOR E. R. BIRCHARD, B. A. Sc., has joined the forces of the Republic Motor Car Co., Toronto, Oldsmobile and Cole distributors, as service manager. Major Birchard has had wide experience in the care and repair of motor vehicles. Previous to enlisting in 1914, in the Eaton Machine Gun Battery, he was in charge of the experimental department, and the trouble de-

partment of the Russell Motor Car Co., Ltd. Major Birchard is a graduate of Toronto University.

“innards” ripped right out Saturday night. The time was about 5 o'clock, the place near Aldershot. At a spot very close to the village the driver apparently lost control, for the auto apparently left the concrete, crossed the ditch without mishap, went out into a frozen field (there being no fence at that point), turned right around, returned to the ditch along which it ran with two wheels in the ditch and the other pair of wheels up on the highway, until the machinery was torn out by being dragged over the frozen ground. The top and body of the car are still in fine shape.

### AUTOMOBILES IN CITIES

A COMMISSION has been appointed in Paris to study automobile traffic and suggest some better system of handling the cars and safeguarding pedestrians. Paris is not alone in facing this problem. London, New York, Chicago and other large cities are almost in despair at the volume of motor traffic and the apparent impossibility of coping with it. Every city, large or small, is involved in the same trouble.

What is to be done when all the automobiles in a community insist on crowding into the down-town section at the same time?

The situation has developed so suddenly that even the newest boom-city, laid out in order to suit the demands of modern civilization, is hardly prepared to handle it. The older the city, the worse the traffic congestion. The

streets were never intended to accommodate a line of parked cars along each curb, with two other lines in continuous and opposite motion, with perhaps trolley cars running along the middle, and vehicular traffic crossing at every intersection, and pedestrians complicating the mix-up by streaming through at every cross-walk.

It gets worse all the time. What is to be done with the parked cars, and how are the moving cars to be kept in motion with the least friction and peril? Must there be great public garages built down town, in every city, under the streets or in the basements of office buildings or elsewhere, to take the standing cars off the streets? Must there be a transformation of the street and sidewalk system, with some streets for cars only and others for walkers only, or different street levels for cars and pedestrians and trolleys?

Here is a transportation problem just as serious as any connected with the railroads, and of more immediate interest to great numbers of people. Where is the genius that can solve it—and persuade the public to spend the money that the solution will probably require?

### ITALY NEEDS IMPLEMENTS

There is a good market in Italy for agricultural implements and machinery. The needs of Italy in this particular were set forth by the Department of Agriculture of that country, as follows: 30,000 plows, 20,000 sowers, 3,000 scrapers and weeders, 9,000 reapers, 2,000 binders, 2,000 harrows, 800 rakes, 1,500 threshing machines, 500 hay presses and 1,000 tractors. This equipment is required in Italy at the earliest possible moment, and while the department expressed the hope that it might be manufactured within that country, they admitted that this was impossible under current conditions of industry there.

### MOTORISTS' RIGHTS

OTTAWA.—The Ottawa Electric Railway Company has issued a statement, concerning street traffic, which is likely to cause trouble between automobile owners and the company. The statement in effect means, that the company, claiming right of way at all times on streets traversed by its lines, and over all traffic, intends to institute suit in the courts where autos collide with its street cars doing damage to them, when reckless driving on the part of the drivers of said autos has been in evidence.

### FINE TRACTOR SLOGAN

LONDON.—J. W. Kilbride, Strathroy, I.H.C. salesman in Sarnia district, is noted as a magic tractor business writer, and has a fine motto (or slogan): “Count that day lost whose descending sun sees not at least one tractor order won.”

### HOUSE ORGAN GROWING

“Canadian Tractor Farming,” Canadian I.H.C. house organ, is growing rapidly, since its inception a year ago, and plans in the near future to print talks dealing more particularly with the different parts of the I.H.C. tractors.

His Reason.—Redhead—“Why did you quit your job? Did you have a disagreement with your boss?”

John Blank—“Oh, no, not at all. I told him I had to have more money or I would quit, and he said that was mutually satisfactory.”

TORONTO.—Fred W. Schuch has severed his connection with Willys-Overland and joined the staff of the G. B. M. Motor (G. E. Gooderham & Co.), Studebaker and Chevrolet distributors.



This shows the world's largest gang plow, with fifty shares. (Courtesy the Guaranty Trust Co., Toronto and New York.)

F. E. Raymond



**MAYBE ADAM  
LAUGHED  
AT THESE**

*The Cheerful Flivver.*—"He says that he never lets anything pass him."  
"You ought to see him when the plate comes along in church."—*Goodyear News.*

\* \* \*

*No Speed, No Speed.*—Host—"What delayed you? Did you have to change a tire?"

Guest—"No, my wife had to change attire."

\* \* \*

*Supplying the Fire.*—The man of law—"But, my dear madam, there is no insurance money for you to draw. Your late husband never insured his life; he only had a policy against fire."

*The Wonderful Widow.*—"Precisely. That is the very reason I had him cremated!"—*London Passing Show.*

\* \* \*

*Studying the Case.*—"You're under arrest," exclaimed the officer, as he stopped the automobile.

"What for?" inquired Mr. Chuggins. "I haven't made up my mind yet. I'll just look over your lights, an' your license, an' your numbers, an' so forth. I know I can get you for somethin'."

\* \* \*

*Removal Notice.*—George (affectionately)—"Helen, dear I've had something hesitating on my lips for some time now and—"

Helen (interrupting)—"Oh, George, how I do hate those little mustaches."—*Lehigh Burr.*

\* \* \*

*Auto Epigramotaphs.*—At 60 miles Across he flew  
The fast mail came  
At 62.  
These bones of Bill's  
Do not disturb;  
At 60 miles  
He hit the curb.—*Detroit News.*

\* \* \*

*Engine Casualties.*—"He says that his engine reminds him of a casualty list."

"How so?"  
"Because it is always either dead or missing."—*Goodyear News.*

\* \* \*

*Her Turn Next.*—Jones had recently been married. The evening of his first pay day he gave his bride fourteen dollars of the fifteen dollar salary, and kept only a dollar for himself. But the second pay day, Jones gave his wife one dollar and kept fourteen for himself.

"Why, Jones," she protested in injured tones, "how on earth do you think I can manage for a whole week on a paltry dollar?"

"Darned if I know," was the cheerful answer. "I had a rotten time myself last week. It's your turn now."

\* \* \*

*Humor and Garage Signs.*—Some of the signs to be found on garages are surely right to the point. In one garage is a very conspicuous sign immediately over the work bench, which reads: "Don't take the tools unless you want to die." Another garage sign is displayed which evidently had been written by someone who was "bothered to death and then some" by people who took things which did not belong to them. The sign was as follows: "Notice To Whom It May Concern: If you want to take something, please take something worth while, like a piano, or pool table, or a clock. Please leave tools alone as they are worth something to us and we want to use them once in a while." Another man, this time a little more emphatic: "Notice: The Lord helps the man who helps himself; but Lord help the man caught helping himself here."—*Goodyear News.*

## Hotter Spark Means More Power in Your Car

The way your car responds with an M. & S. Spark Plug is an eye-opener. The hotter the spark the quicker response from your engine. M. & S. Spark Plugs produce a hotter spark. The heavy ball-point concentrates the current and intensifies the heat. —Quicker ignition—more complete combustion and better results in general.

And the one-piece center electrode is 97% nickel-steel—which reduces the danger of carbon fouling. The high grade porcelain has perfect chemical glaze unaffected by heat. High heat test ensures against spark troubles. And mark this—

M. & S. porcelain is *interchangeable*. One porcelain fits all plugs.

The Three-in-one Terminal is adapted to any style ignition wiring. Special Chevrolet model ball terminal. (M. & S. Spark Plug No. 500 is standard equipment on Model 4 Overland).

M. & S. plugs are *Made-in-Canada* by Canadian workmen.

Tip-top quality of both material and workmanship and the most exacting tests warrant our guarantee of complete satisfaction—or free repair or replacement.

*Dealers! Order from your nearest Jobber or write direct for descriptive circular.*

**M. & S. Spark Plug No. 500 is Standard Equipment on Model No. 4 Overland**

No. 500  
1/2" Standard with Three-in-One Terminal

Made in Canada

# M & S

**The Plug with the Hotter SPARK**

**Machine & Stamping Co., Limited**  
Commercial Dept.—Russell Motor Car Co., Limited  
1209 King Street West, Toronto, Ontario

Also Models No. 501, 3/8 inch Standard with "3 in 1" Terminal; No. 502, 3/8 inch long with "3 in 1" Terminal; No. 503, 3/8 inch with Chevrolet Ball Terminal; No. 506, 1/2 inch long with "3 in 1" Terminal; No. 504, Regular Porcelain with "3 in 1" Terminal and Gaskets; No. 505, Porcelain with Chevrolet Ball Terminal and Gaskets.

## Costs Little—But



**T**HOUGH you protect your home—your barn—your stock with insurance against fire does not free you from the loss following damage to many valuable documents and papers that maybe you now keep in an ordinary locked drawer.

The extra protection against fire, loss or theft outweighs the slight cost of installing a "Taylor" 199—It just fits the Farm Home.

Dealers and supply houses write for terms.

**J. & J. Taylor  
LIMITED**  
Toronto Safe Works  
TORONTO

Be Sure to See the Exhibit of the J. I. Case Threshing Machine Company at the Minneapolis Tractor Show, January 31 to February 7. Tractors and Other Power Farming Equipment in space H-2, Overland Building.



Don't Fail to See the  
**National Motor Show**  
of Eastern Canada

Held in the

**"MOTORDROME"**

228 Sherbrooke St. East, near St. Denis St., Montreal

as the

**1920 - MONTREAL MOTOR SHOW - 1920**

January 17th to 24th, inclusive

under the auspices of



The

**Montreal Automobile Trade Association**

Limited

Room 64 Dandurand Building - Tel. East 2566

294 St. Catherine East

**MONTREAL**

*The Biggest and Best Automobile Show Ever Held in Canada*





# Champion

## Dependable Priming Plugs

*Put Quick Life Into a Cold Motor and  
Eliminate Most Cold Weather  
Motor Troubles.*

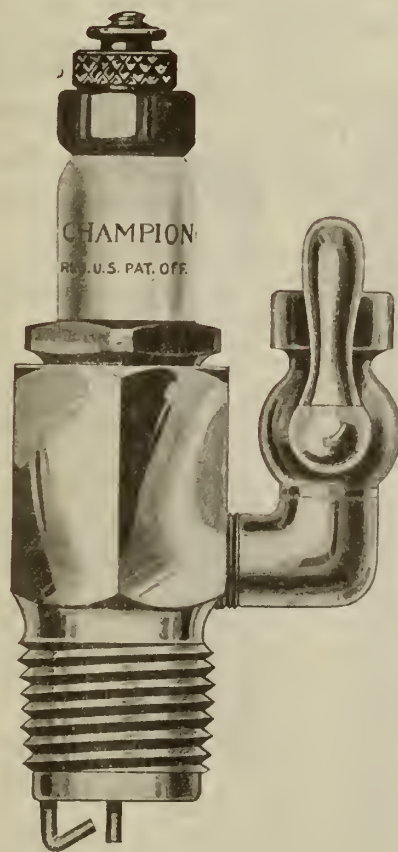

**CHAMPION**  
Priming Plug  
Price \$1.50

They insure a quick, sure start, even in coldest weather. They do away with unnecessary worry, cranking, wear and tear on starter, the exhaustion of batteries and wastage of gasoline.

Champion Priming Plugs in all cylinders put the gasoline at the vital spot—the sparking point where it gets a big hot spark on the first revolution of the engine.

Champion Priming Plugs enable the driver to stop the engine when car or truck is standing idle, thereby conserving gasoline.

Every Motor Car owner needs Champion Priming Plugs from now until next April. Get a set now and motor in comfort.

If you are an accessory dealer or garage man, a stock of Champion Plugs will guarantee a service that your customers will appreciate, and help to increase sales in a dull period.

*Your jobber has them*

**Champion Spark Plug Company  
of Canada, Limited**

WINDSOR

ONTARIO

*A Prime Saves Time, Worry, Equipment  
and Gasoline*



# CANADIAN Motor Tractor and Implement Trade Journal BUYERS DIRECTORY

This directory will help you with your buying and your planning. The advertisers listed here are thoroughly reliable and leaders in their respective fields. They are looking for live, wide-awake representatives. Study their advertisements carefully because they contain valuable information which will dovetail with your plans. We are glad to go to the trouble of arranging this list—to make it easy for you to select new lines. If it so happens that what you want is not here, write us, and we will tell you where to get it.

## AUTO ACCESSORIES

Can. Fairbanks-Morse Co., Ltd., Montreal.  
Kales Stamping Co., Detroit, Mich.  
Kinzinger Bruce Co., Niagara Falls, Ont.  
Machine and Stamping Co., Ltd., Toronto  
Northern Electric Co., Ltd., Montreal.  
Champion Spark Plug Co., Windsor, Ont.  
The Greb Co., Boston.  
Casco Mfg. Co., Thomasville, Ga., U.S.A.  
McKenzie, Crew & Co., Toronto.  
Robinson, Edward A., Co., Ltd., Montreal.

## AUTOMOBILE CHAINS

Can. Fairbanks-Morse Co., Ltd., Montreal.  
Can. General Electric Co., Ltd., Toronto.

## AXLE GREASE

A. W. Harris Oil Co., Providence, R. I.

## BARN EQUIPMENT

Beatty Bros., Ltd., Fergus, Ont.

## BEAN MACHINERY

John Deere Mfg. Co., Welland, Ont.

## BEET MACHINERY

John Deere Mfg. Co., Welland, Ont.

## BINDERS

The Frost & Wood Co., Ltd., Smiths Falls, Ont.  
International Harvester Co., Ltd., Hamilton, Ont.

## BELTING

The Renfrew Machinery Co., Ltd., Renfrew, Ont.

## BATTERIES

Can. Fairbanks-Morse Co., Ltd., Montreal.  
The Renfrew Machinery Co., Ltd., Renfrew, Ont.

## CARRIAGES

Cockshutt Plow Co., Brantford, Ont.

## CREAM SEPARATORS

De Laval Co., Ltd., Peterboro, Ont.  
King Separator Co., Bridgeburg, Ont.  
R. A. Lister Co., (Canada) Ltd., Toronto.  
The Renfrew Machinery Co., Ltd., Renfrew, Ont.  
Sharples Separator Co., Toronto.

## CEMENT MIXERS

Can. Fairbanks-Morse, Ltd., Montreal.

## CASTINGS

Joliette Steel Co., Joliette, P.Q.

## CORN HARVESTERS

Cockshutt Plow Co., Brantford, Ont.

## CORN MACHINERY

John Deere Mfg. Co., Welland, Ont.

## CULTIVATORS

Cockshutt Plow Co., Brantford, Ont.  
John Deere Mfg. Co., Welland, Ont.  
The Frost & Wood Co., Ltd., Smiths Falls, Ont.  
Peter Hamilton Co., Ltd., Peterborough, Ont.  
International Harvester Co., Ltd., Hamilton, Ont.

## CUTTERS

Butterfield & Co., Inc., Rock Island, Que.

## DAIRY SUPPLIES

International Harvester Co., Ltd., Hamilton, Ont.  
R. A. Lister Co., (Canada) Ltd., Toronto.

## DITCHING MACHINES

Can. Fairbanks-Morse Co., Ltd., Montreal.

## DRILLS, TWIST

Butterfield & Co., Ltd., Rock Island, Que.

## DIES

Butterfield & Co., Inc., Rock Island, Que.

## DRILLS, GRAIN

Cockshutt Plow Co., Brantford, Ont.  
John Deere Mfg. Co., Welland, Ont.  
The Frost & Wood Co., Ltd., Smiths Falls, Ont.  
Peter Hamilton Co., Ltd., Peterborough, Ont.

## ENGINES

Can. Fairbanks-Morse Co., Ltd., Montreal.  
Gilson Mfg. Co., Ltd., Guelph, Ont.  
International Harvester Co., Ltd., Hamilton, Ont.  
John Deere Mfg. Co., Welland, Ont.  
R. A. Lister Co., (Canada) Ltd., Toronto.  
The Renfrew Machinery Co., Ltd., Renfrew, Ont.  
Fisher, Wilkie, Ltd., Sandwich, Ont.  
Sharples Separator Co., Toronto.

## ENSILAGE CUTTERS

Can. Fairbanks-Morse Co., Ltd., Montreal.  
Peter Hamilton Co., Ltd., Peterborough, Ont.  
Matthew Moody & Sons Co., Terrebonne, P.Q.  
The Renfrew Machinery Co., Ltd., Renfrew, Ont.

## FEEDERS

John Deere Mfg. Co., Welland, Ont.

## FARM MACHINERY

Can. Fairbanks-Morse Co., Ltd., Montreal.  
Cockshutt Plow Co., Brantford.  
Fisher, Wilkie, Ltd., Sandwich, Ont.

John Deere Mfg. Co., Welland, Ont.

Peter Hamilton Co., Ltd., Peterborough, Ont.  
International Harvester Co., Ltd., Hamilton, Ont.  
The Frost & Wood Co., Ltd., Smiths Falls, Ont.  
R. A. Lister Co., (Canada) Ltd., Toronto.  
Matthew Moody & Sons Co., Terrebonne, P.Q.  
The Renfrew Machinery Co., Ltd., Renfrew, Ont.

## FEED CUTTERS

Can. Fairbanks-Morse Co., Ltd., Montreal.  
Peter Hamilton Co., Ltd., Peterborough, Ont.  
Renfrew Machinery Co., Ltd., Renfrew, Ont.

## FINANCIAL

The Commercial Credit Co. of Canada, Ltd., Toronto.

## GRINDSTONES

S. Vessot & Co., Joliette, P.Q.

## GRINDERS

Can. Fairbanks-Morse Co., Ltd., Montreal.  
Fleury's Sons, J., Aurora, Ont.  
International Harvester Co., Ltd., Hamilton, Ont.  
R. A. Lister Co., (Canada) Ltd., Toronto.  
The Renfrew Machinery Co., Ltd., Renfrew, Ont.  
S. Vessot & Co., Joliette, P.Q.

## GREASES

A. W. Harris Oil Co., Providence, R.I.

## HARROWS

Cockshutt Plow Co., Brantford, Ont.  
John Deere Mfg. Co., Welland, Ont.  
The Frost & Wood Co., Ltd., Smiths Falls, Ont.  
Peter Hamilton Co., Ltd., Peterborough, Ont.  
The Matthew Moody & Sons Co., Terrebonne, Que.

## HARDWARE

Can. Fairbanks-Morse Co., Ltd., Montreal.

## HAY LOADERS

John Deere Mfg. Co., Welland, Ont.  
The Frost & Wood Co., Ltd., Smiths Falls, Ont.

## HAY RAKES

John Deere Mfg. Co., Welland, Ont.  
The Frost & Wood Co., Ltd., Smiths Falls, Ont.  
Peter Hamilton & Co., Ltd., Peterborough, Ont.

## HAY CARRIERS

Beatty Bros., Ltd., Fergus, Ont.

## HAY PRESSES

Birdsell Mfg. Co., Toronto

## HULLERS (Clover)

Birdsell Mfg. Co., Toronto

## LIGHTNING SYSTEMS

Can. Fairbanks-Morse Co., Ltd., Montreal.  
Can. General Electric Co., Ltd., Toronto.  
R. A. Lister Co., (Canada) Ltd., Toronto.  
Northern Electric Co., Ltd., Montreal.

## LIME AND FERTILIZER SOWERS

John Deere Mfg. Co., Welland, Ont.

## MANURE CARRIERS

Beatty Bros., Ltd., Fergus, Ont.

## MANURE SPREADERS

Cockshutt Plow Co., Brantford, Ont.  
John Deere Mfg. Co., Welland, Ont.  
The Frost & Wood Co., Ltd., Smiths Falls, Ont.  
International Harvester Co., Ltd., Hamilton, Ont.  
The Matthew Moody & Sons Co., Terrebonne, Que.

## MARINE FITTINGS

The Northern Electric Co., Ltd., Montreal.

## MOWERS

Cockshutt Plow Co., Brantford, Ont.  
The Frost & Wood Co., Ltd., Smiths Falls, Ont.  
Peter Hamilton Co., Ltd., Peterborough, Ont.

## MILKING MACHINES

R. A. Lister Co., (Canada) Ltd., Toronto.  
Sharples Separator Co., Toronto.

## MILLING CUTTERS

Butterfield & Co., Inc., Rock Island, Que.

## NATIONAL MOTOR SHOW

The Montreal Automobile Trade Association, Ltd., Montreal.

## NUT LOCKS

Robinson, Ed. A., Co., Ltd., Montreal.

## ORCHARD TOOLS

Peter Hamilton Co., Ltd., Peterborough, Ont.

## OILS

A. W. Harris Oil Co., Providence, R.I.  
The Renfrew Machinery Co., Ltd., Renfrew, Ont.

## PISTON RINGS

Pressure Proof Rings, Ltd., Sherbrooke, Que.  
WedgeRite Piston Ring Co., Ltd., Montreal.

## PLOWS

Cockshutt Plow Co., Brantford, Ont.  
Fleury's Sons, J., Aurora, Ont.  
John Deere Mfg. Co., Welland, Ont.  
The Frost & Wood Co., Ltd., Smiths Falls, Ont.  
Peter Hamilton Co., Ltd., Peterborough, Ont.  
International Harvester Co., Ltd., Hamilton, Ont.  
The Renfrew Machinery Co., Ltd., Renfrew, Ont.

## POLICE AND FIRE ALARM EQUIPMENT

The Northern Electric Co., Ltd., Montreal.

## POWER MACHINERY

Can. Fairbanks-Morse Co., Ltd., Montreal.  
John Deere Mfg. Co., Welland, Ont.  
Peter Hamilton Co., Ltd., Peterborough, Ont.  
International Harvester Co., Ltd., Hamilton, Ont.

## POWER AND LIGHT EQUIPMENT

The Northern Electric Co., Ltd., Montreal.

## POWER SWITCHBOARDS

The Northern Electric Co., Ltd., Montreal.

## POTATO MACHINERY

John Deere Mfg. Co., Welland, Ont.  
Matthew Moody & Sons Co., Terrebonne, Que.  
Cockshutt Plow Co., Brantford, Ont.

## PULVERIZERS

Cockshutt Plow Co., Brantford, Ont.

## PULPERS

Cockshutt Plow Co., Brantford, Ont.

## RAKES

The Frost & Wood Co., Ltd., Smiths Falls, Ont.

## REAPERS

The Frost & Wood Co., Ltd., Smiths Falls, Ont.

## REAMERS

Butterfield & Co., Inc., Rock Island, Que.

## ROLLERS

Cockshutt Plow Co., Brantford, Ont.

## SAW MILL OUTFITS

Matthew Moody & Sons Co., Terrebonne, Que.

## SCUFFLERS

Cockshutt Plow Co., Brantford, Ont.  
John Deere Mfg. Co., Welland, Ont.

## SCREW PLATES

Butterfield & Co., Inc., Rock Island, Que.

## SPARK PLUG CLEANERS

Champion Spark Plug Co., Windsor, Ont.

## STABLE EQUIPMENT

Beatty Bros., Ltd., Fergus, Ont.

## SILOS

Gilson Mfg. Co., Guelph, Ont.

## SLEIGHS

Cockshutt Plow Co., Brantford, Ont.

## SILO FILLERS

Gilson Mfg. Co., Guelph, Ont.

## SPREADERS, MANURE

Cockshutt Plow Co., Brantford, Ont.  
John Deere Mfg. Co., Welland, Ont.  
International Harvester Co., Ltd., Hamilton, Ont.

## SAFES

J. & J. Taylor, Ltd., Toronto.

## SPARK PLUGS

Champion Spark Plug Co., Windsor, Ont.  
Machine and Stamping Co., Ltd., Toronto.  
The Silvex Co., Bethlehem, Penn.

## TRACTORS

Advance-Rumely Thresher Co., La Porte, Ind.  
R. A. Lister & Co. (Canada) Ltd., Toronto.  
Canadian Allis-Chalmers, Ltd., Toronto.  
Cleveland Tractor Co., Windsor, Ont.  
Gilson Mfg. Co., Guelph, Ont.  
Huber Mfg. Co., Marion, Ind.  
International Harvester Co., Ltd., Hamilton, Ont.  
J. I. Case Co. Thresh'g Mach. Co., Inc., Racine, Wis.  
The Turner Mfg. Co., Port Washington, Wis.

## TRACTOR PLOWS

Cockshutt Plow Co., Brantford, Ont.  
International Harvester Co., Ltd., Hamilton, Ont.

## TELEPHONE APPARATUS

The Northern Electric Co., Ltd., Montreal.

## THRESHERS

Can. Fairbanks-Morse Co., Ltd., Montreal.  
J. I. Case Threshing Mach. Co., Inc., Racine, Wis.  
R. A. Lister Co., Ltd., Toronto.  
Matthew Moody & Sons Co., Terrebonne, Que.  
The Renfrew Machinery Co., Ltd., Renfrew, Ont.

## THREAD CUTTING TAPS

Butterfield & Co., Inc., Rock Island, Que.

## TWIST DRILLS

Butterfield & Co., Inc., Rock Island, Que.

## TRUCKS

Beaver Truck Builders, Limited, Hamilton, Ont.  
Eastern Canada Motor Truck Co., Ltd., Hull, P.Q.

## WHEELBARROWS

Cockshutt Plow Co., Brantford, Ont.

## WAGONS

Cockshutt Plow Co., Brantford, Ont.  
International Harvester Co., Ltd., Hamilton, Ont.

## WATER BOWLS

Beatty Bros., Ltd., Fergus, Ont.

## WIRES AND CABLES

The Northern Electric Co., Ltd., Montreal.

## WEEDERS

Cockshutt Plow Co., Brantford, Ont.



# Butterfield

## Drills, Taps, Dies, Reamers and MILLING CUTTERS

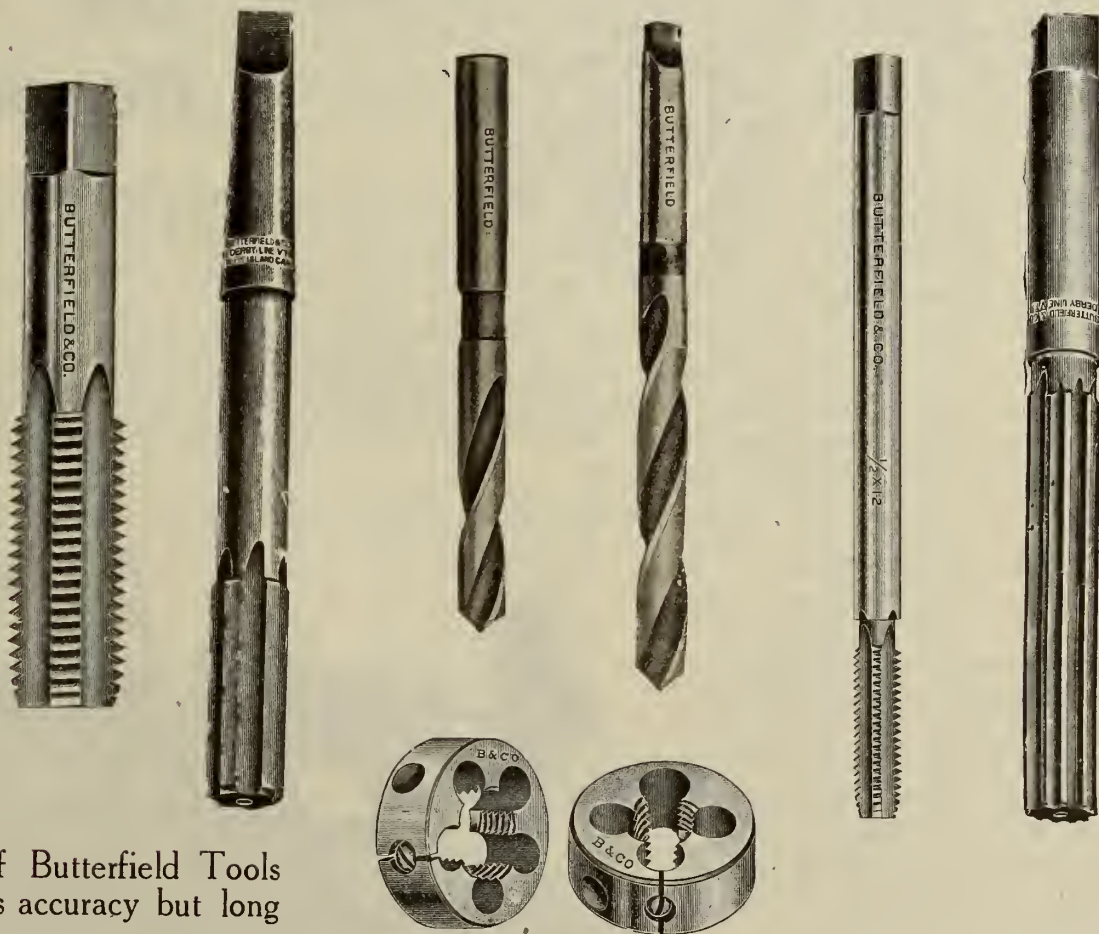

The quality of Butterfield Tools not only ensures accuracy but long service and economy.

Try them and you soon will be convinced that they play an important part in keeping down the overhead in repairs.

**TOOLS THAT  
KEEP THEIR EDGE**

The use of High Quality Tools on repair work is one of the essentials to the highest class job, and Butterfield Quality is the BEST.

### BUTTERFIELD & CO., INC., ROCK ISLAND, P.Q.

TORONTO OFFICE: 220 King St. W.



*The Moody  
Drag Saw  
Machine*

*Improved  
Design*

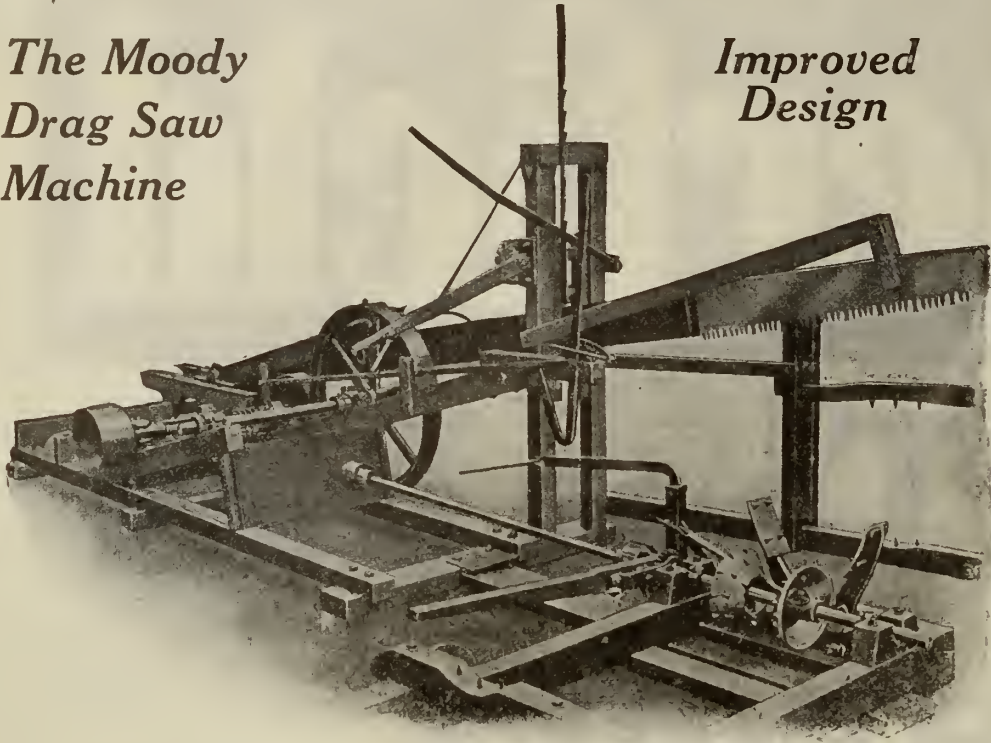

# MATTHEW MOODY SAWS

**The Moody Improved Drag Saw Machine**

Recent and ingenious improvements made on this drag saw have made it superior in service to any machine of its kind on the market. By means of a new special device the saw is put to rest and the self-feed continues running. No stopping is necessary now in moving the log. There's no inconvenience or delay of any kind. Our pressure lever is another new improvement which can be used with convenience when required. Still another new and important feature is the log holder. It permits the convenient cutting of short cord-wood without the slightest danger. The whole outfit is made stable and rigid by a still, hardwood connecting plank. No other machine compares with it for service.

*Handy,  
Strong  
and  
Durable*

Moody Saws are handy, strong and durable. They are first-class machines at low prices. Farmers everywhere are now appreciating the advantage and profit in owning and operating a sawing machine of their own. They can cut their own wood and make money cutting their neighbor's wood, too.

Cutting qualities are not the only essentials to be considered in selecting a good circular saw. Consideration should be given to its safety in operation. This Moody Long Swing Table Saw is designed to be absolutely safe as well as to possess superior cutting qualities. Carefully seasoned hardwood, of ample size and weight, strongly braced and bolted together, give it exceptional strength—no gears, no complicated pieces. Log tables are plated with heavy steel plates and every saw that leaves our factory is equipped with a safety strap around the shaft close up to the circular saw, a precaution against accident in case box of saw shaft or bolt should break.

The machine could not be made safer.

*The Moody Long  
Swing Table Saw*

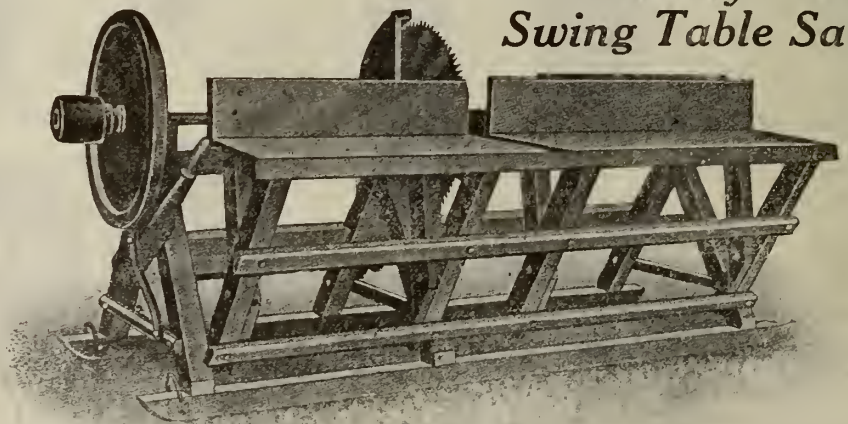

## MATTHEW MOODY & SONS COMPANY

*Head Office: TERREBONNE, QUE.*



# What kind of a tractor are you going to sell this year?

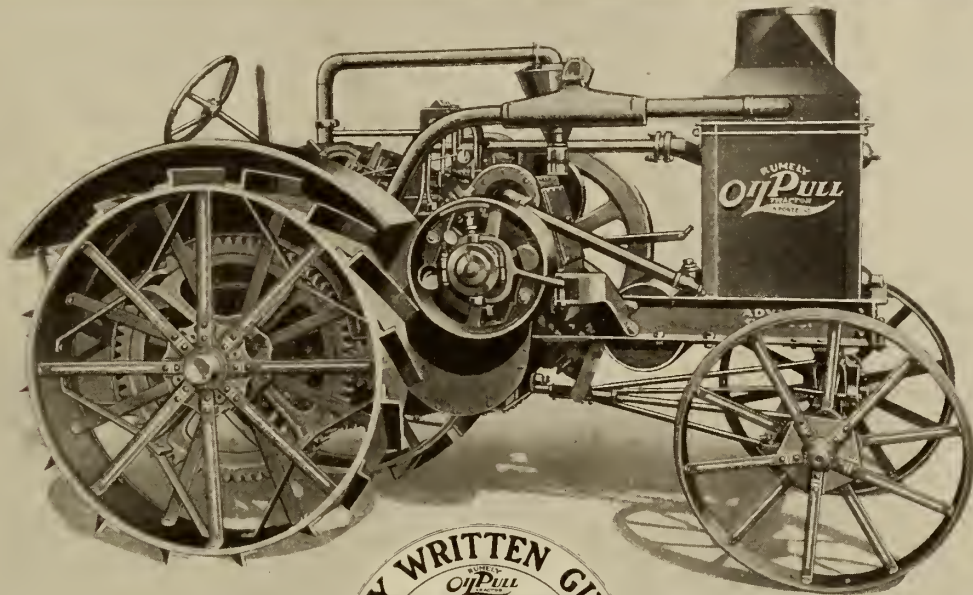

THE 12-20 OILPULL



**U**PON your answer to this question depends largely the tractor profits you will enjoy during the coming season. And the right decision is not difficult to make if you give some study to the matter.

First, you want a tractor combining these qualities that insure a maximum of dependable operation in the field with a minimum of occasion for service. You want a tractor that is not only easy to sell but that stays sold and delivers a brand of performance that sells others.

You want the tractor that has been proved most dependable—that one is the *Rumely OilPull*. Ten years ago the first OilPull tractors were sold for breaking sod in the Northwest—a tough, heart-breaking job. And those same OilPulls have been working steadily ever since. The first OilPull is still on the job—over 15,000 are now in service.

You want the tractor that will operate at the lowest cost—that one is the *Rumely OilPull*. The OilPull is especially made to burn kerosene—not “made over”. From the ground up the OilPull is designed and built to burn oil fuel. *The Rumely OilPull will plow an acre of ground at less cost than any other tractor built.*

You want the tractor that is backed by a written guarantee—that one is the *Rumely OilPull*. Every OilPull tractor is guaranteed in writing to

burn successfully all grades of kerosene under all conditions at all loads to its full rated brake horsepower.

You want the tractor that delivers more power for its size and rating than any other made—that one is the *Rumely OilPull*. All OilPull tractors will deliver 25% more power than their rating.

You want a tractor in which simplicity and ease of operation are “inbuilt”. You find them in the *Rumely OilPull*. No complicated mechanism—all operating levers within easy reach—all working parts carefully protected, yet easily accessible for inspection. High, properly spaced front wheels permit easy steering and operating on rough ground.

You want to represent a tractor manufacturer who backs you with genuine service. Where can you find the equal of *Rumely service*? At each of the 28 branch offices and warehouses, located at central shipping points in the United States and Canada, is carried a complete stock of machines and parts, also an organization of trained tractor experts.

You want a tractor that will fit the power needs of each of your customers. Such is the *Rumely OilPull*, for there are four sizes, standard in design—12-20, 16-30, 20-40 and 30-60 H. P.

Our dealer proposition may help you decide about this year's contract—write for it.

ADVANCE-RUMELY THRESHER COMPANY, Inc.

La Porte, Indiana

Calgary, Alta.  
Saskatoon, Sask.

Regina, Sask.  
Winnipeg, Man.

48 Abell Street, Toronto, Ont.

# ADVANCE-RUMELY





## Mr. Dealer,

The Beaver Agency is a big  
**Money Maker**

The Beaver Truck, which is the result of actual truck knowledge, based on approved engineering, is

### Canada's Lowest Hauling Cost

We can prove these statements by comparative demonstrations---by comparative values.

*Write for full details and Agency Proposition*

---It is built on sound engineering practice and built to endure.

---It is built by Canada's largest exclusive truck factory.

---It is built by men long experienced in the manufacture of motor-trucks and who know Canada's transportation problems.

---Part of the large saving in duty on American trucks is put into extra built-in value and the balance is deducted from the usual list price of the trucks.

# Beaver Trucks

*Manufactured in Canada by*

---

**Beaver Truck Builders, Limited, Hamilton, Ont.**

---



# CANADIAN MOTOR, TRACTOR AND IMPLEMENT TRADE JOURNAL

Published Monthly by THE MACLEAN PUBLISHING COMPANY, LIMITED, TORONTO

MONTREAL, Southam Bldg. WINNIPEG, 1103 Union Trust Bldg. VANCOUVER, 39 10th Ave. West. LONDON, ENG., 88 Fleet St., E.C. 4. NEW YORK, 1133 Broadway. BOSTON, 734 Old South Bldg. CHICAGO, 1401 Lytton Bldg

VOL. II, No. 2

TORONTO, FEBRUARY, 1920

Subscription Price  
\$1.00 Per Year

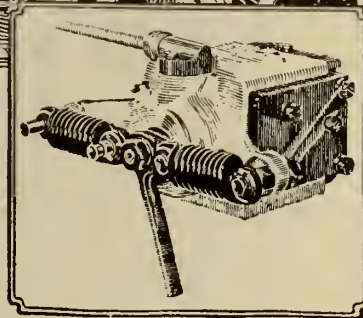
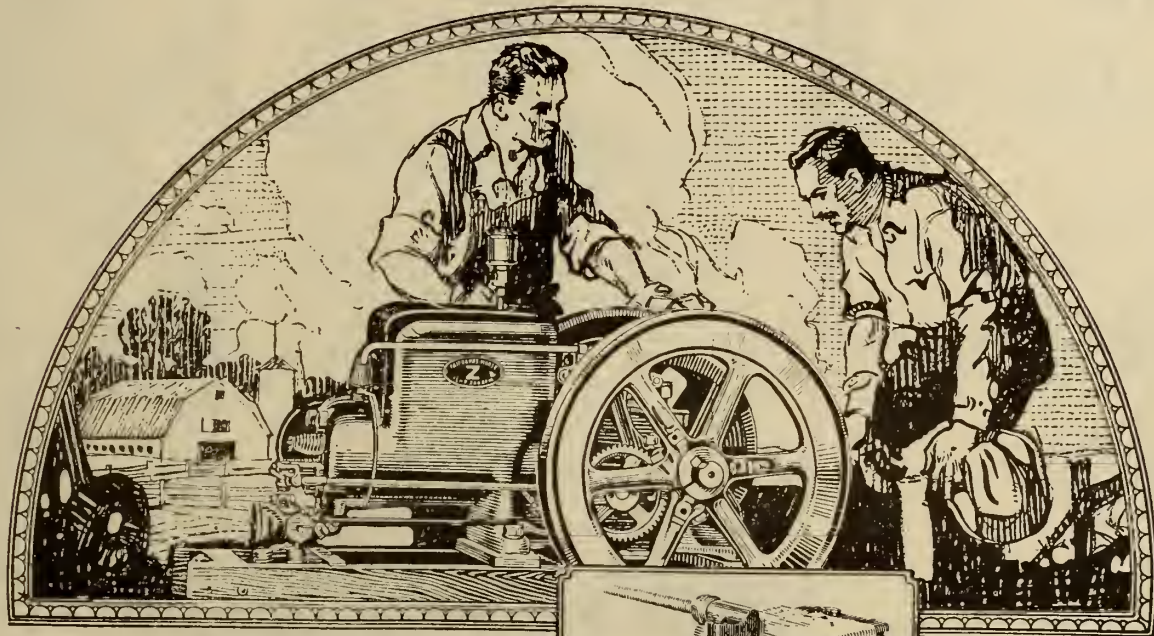

*Fairbanks-Morse  
"Z" Engine with  
Bosch Magneto*

## Farm Engine Supremacy

The famous "Z" Engine and the Bosch high-tension, oscillating magneto combine to make the one SUPREME farm engine. The dependability of the Bosch in delivering a steady succession of hot, intensive sparks is well known, and adds the one possible betterment to the "Z"—always recognized as the foremost of farm engines. Ask your customers to see the results of this newest combination—FAIRBANKS-MORSE "Z" WITH BOSCH MAGNETO. It will multiply farm engine sales—sales of the "Z", the choice of over 250,000 farmers.

*Made in Toronto and Guaranteed by*

*The Canadian*  
**Fairbanks-Morse**

Halifax St. John Quebec Montreal Ottawa Toronto  
Hamilton Windsor Winnipeg Saskatoon  
Calgary Vancouver Victoria

*Co., Limited.*





# The Wedge Does It

## The Mighty Force that Holds the Reins of Power

The finest motor in the world cannot deliver the power which it is otherwise capable of furnishing if there is loss of compression.

To fully protect themselves against loss of compression by their engines, thousands of motorists are utilizing the mighty force of the "Wedge"—by installing WEDGERITE PISTON RINGS.

As the WEDGERITE equipped piston comes up on the compression stroke the impenetrable "wedge" pressure of these remarkable Rings prevents the slightest escape of gas or oil. Result: Perfect compression; 100% generation of power.

Ask your repair man to show you these fuel and tire-saving rings.

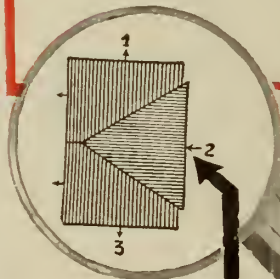
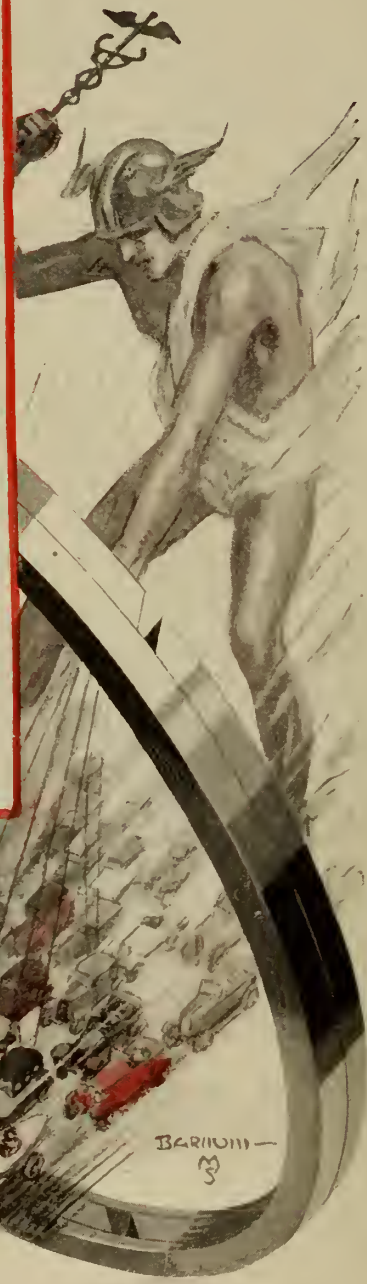

THE  
WEDGE



CROSS SECTION OF RING  
SHOWN IN CIRCLE

- 1—Section pressing outward and upward.
- 2—Spring section of ring.
- 3—Lower outward and downward section.

### ILLUSTRATING THE WEDGE PRINCIPLE

The wedge principle employed in the making of WedgeRite Piston Rings is shown in the accompanying drawing. Its superiority, measured by its ability to expand in WIDTH as well as in diameter, means utmost satisfaction for motorists. The repairman who uses WedgeRite Rings is one who can be trusted. By using the Best Piston Ring he shows a real desire to give you better repair service.

**Dealers and Garagemen**—The only profitable trade is that built up of satisfied customers. Sell WEDGERITE PISTON RINGS and quickly add to your list of satisfied customers.

Write for further information.

# Wedge Rite

PISTON RING  
COMPANY  
LIMITED

92 Notre Dame St. E., Montreal

AT ALL DEALERS AND GARAGES



# A Good Name Everywhere

Users are always boosters

# Lister

POWER ON THE FARM

The high grade, dependable line of  
**FARM AND DAIRY MACHINERY**

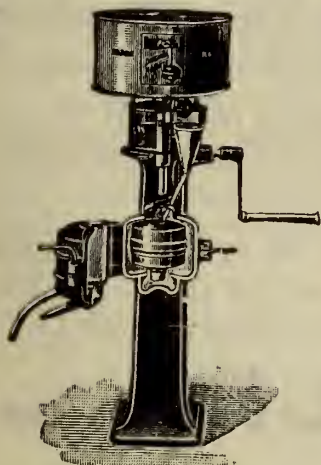

**The "Melotte" Cream Separator**

The Original Melotte—a marvel in skimming efficiency, ease of operation and long life.

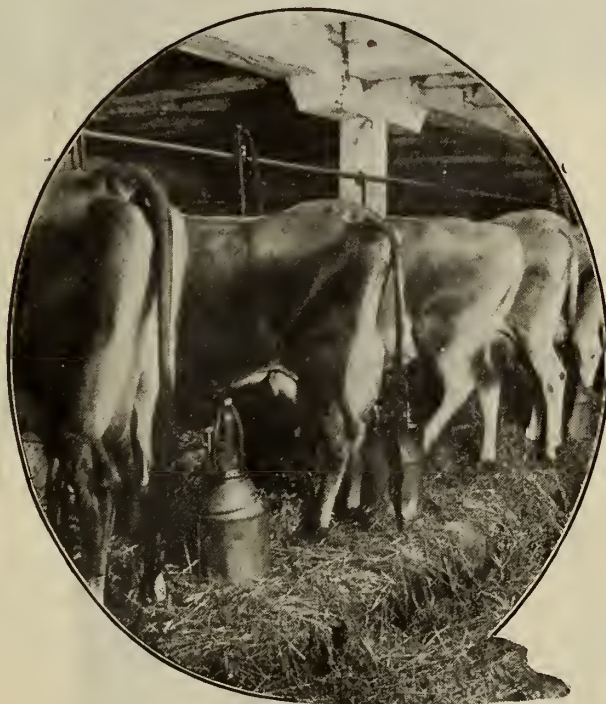

**The "Lister" Milker**

"A wonderful milker"—say users everywhere. Thousands in daily use. Can be used on all grades and breeds with entire safety.

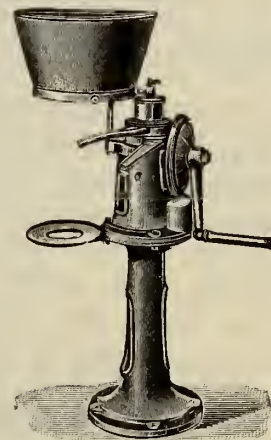

**The "Premier" Cream Separator**

British made — and its service shows it. Easy to operate. Easy to clean.

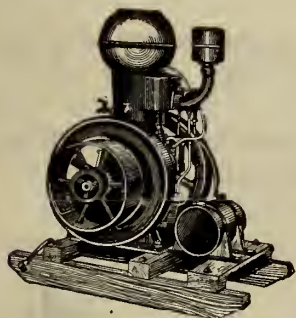

**The "Lister" Engine**

A leader in efficiency, workmanship and equipment. Compare the "Lister" with any of its competitors and its superiority will at once be obvious to you.

**"Lister" Silos**

The care used in the construction of the "Lister" Silo is equal to that employed in the other top-quality Lister lines. Every Lister Silo you sell ensures a satisfied customer.

## "AVERY" TRACTORS

"Avery" Tractors are built in seven sizes—a size for every size farm—and sold at popular prices.

Lister products are business-builders and they pay a good commission. Write for agency proposition.



**The "Lister" Silo**

**R. A. LISTER & CO. (CANADA) LIMITED**

58-60 Stewart Street, TORONTO

Also at Wall Street, WINNIPEG



# —AND WE'LL SEND YOU A CHECK FOR \$1,000

## GILSON dealers are making thousands of dollars selling **HYLO SYLOS** **WHY NOT YOU?**

There's big money in the game!—We want you to get in on it!

You've heard of the HYLO-SYLO! You know that it represents the highest achievement in silo construction.

The HYLO-SYLO puts the Gilson Dealer in the strongest position of any silo agent.

The HYLO-SYLO price is as low as the lowest—and its value is as high as the highest.

It is made of either the well-known Long Leaf Yellow Pine or of Hardy Northern Grown Canadian lumber. The latter is treated in special preservatives. Both are exactly the same in construction.

With this combination you can lock the door on your competitors.

### Do It Now!

You can double your profits—we will show you how!

Write to-day.

You'll hear from us by return mail.

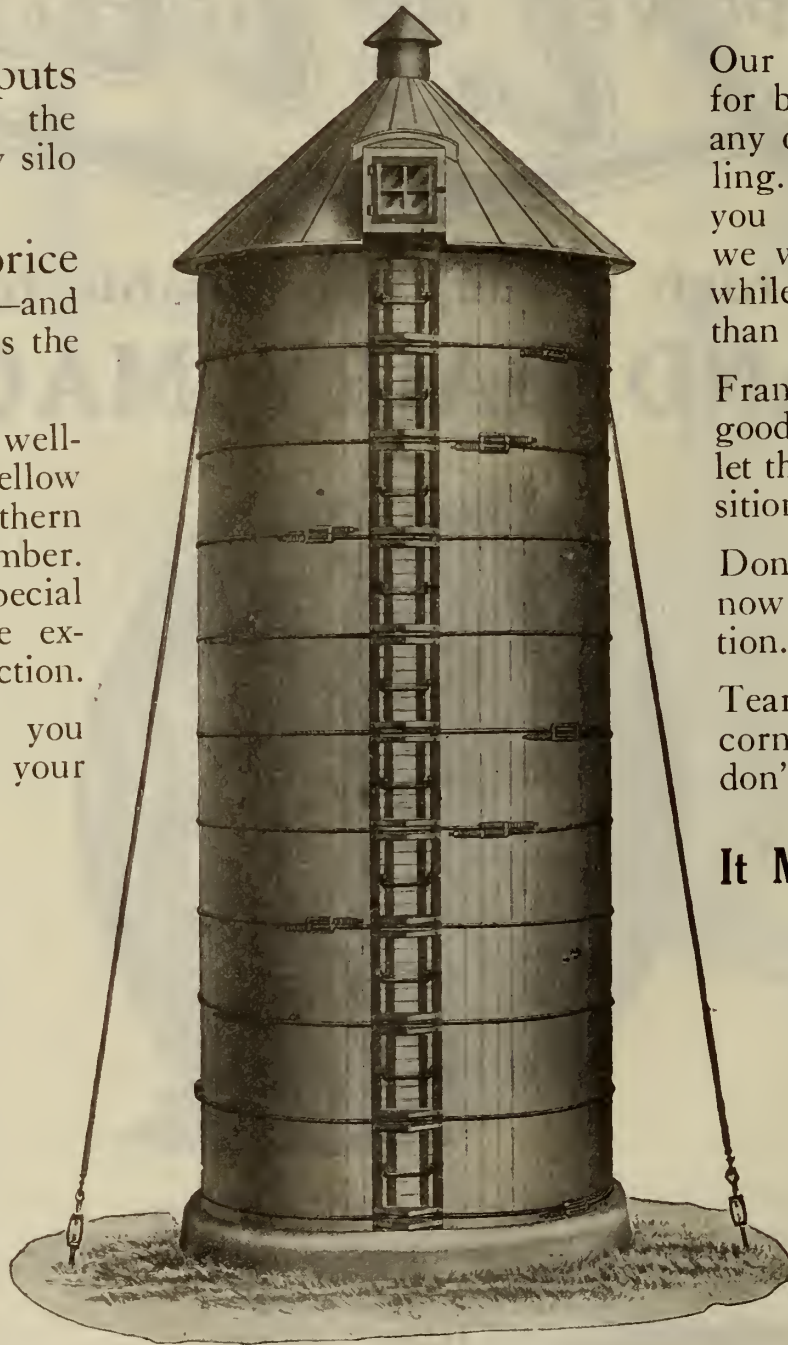

Our 1920 contract provides for bigger commissions than any other line you are handling. We have the goods—you have the connection—we will make it worth your while to push our silos harder than any other goods you sell.

Frankly now, doesn't it look good? You can't afford to let this money-making proposition go!

Don't put it off! Write us now for the agents' proposition.

Tear off, fill in and return the corner of this page. If you don't someone else will!!

### It Means Dollars to You!

No silo is complete without the wonderful Gilson Silo Filler!

It has the largest sale of any under the British flag.

**BIG PROFITS — EASY SELLER.**

Something worth adding to your lines.

## GILSON MFG. CO., LIMITED

Factory and Head Office, Dept. D  
GUELPH, ONT.

Branch and Warehouse  
355 Elgin Ave.  
WINNIPEG, MAN.

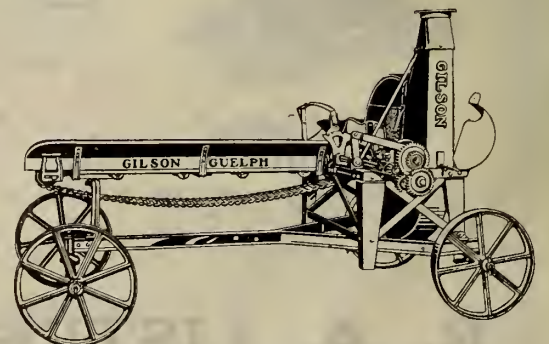

The Wonderful Gilson

**FILL IN AND RETURN AT ONCE!**  
TEAR OFF HERE

Without any obligation on my part you may send me your agent's proposition on:  
(Put an X opposite the product that interests you)

Silo  
 Silo Filler  
 Engine  
 Thresher  
 Tractor  
 Manure Spreader

Name .....  
 Post Office .....  
 R. R. No. ....  
 Remarks .....  
 Prov. ....



**Cletrac**  
TANK-TYPE  
TRACTOR

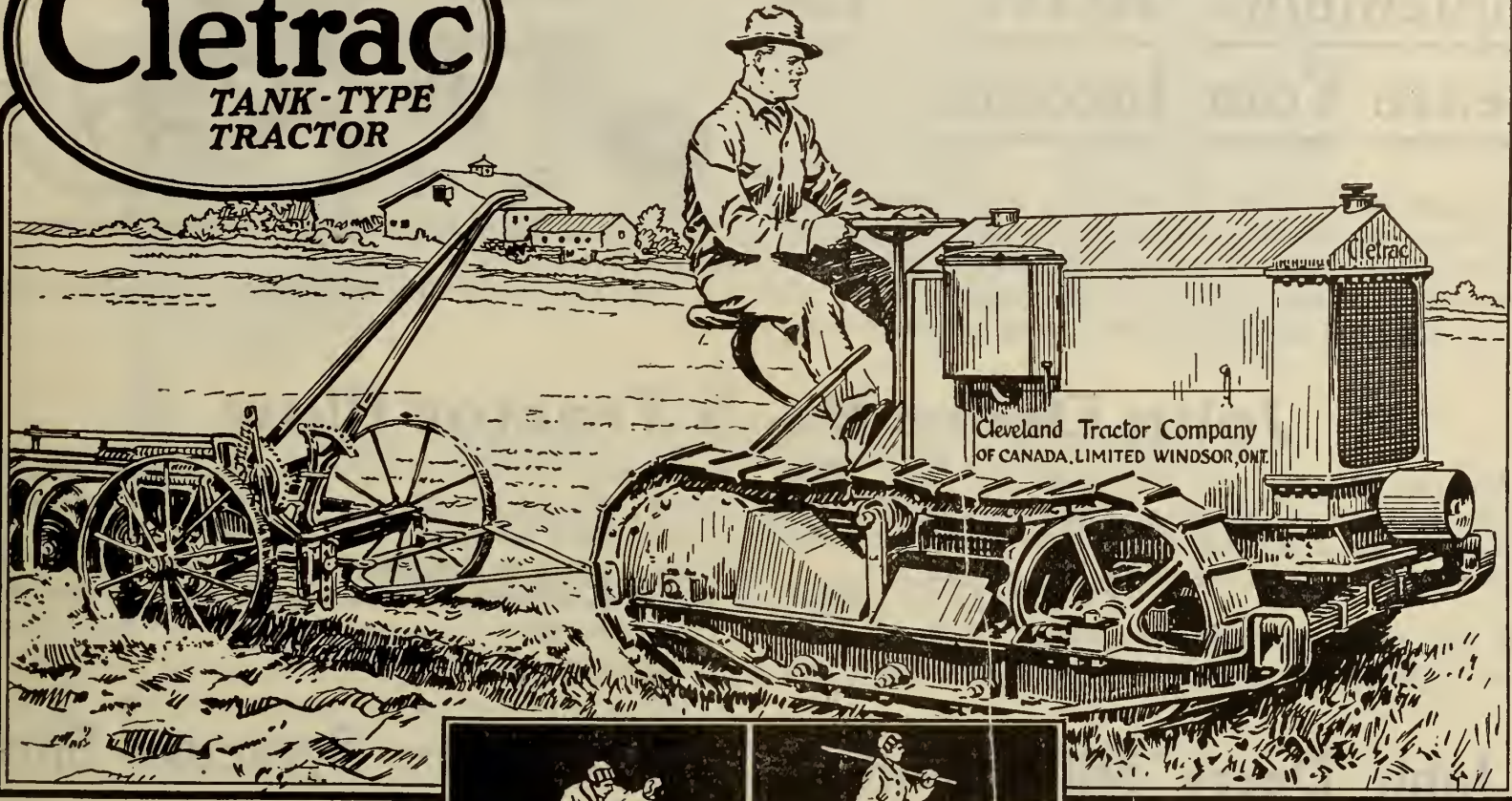

The foot that carries the man's weight has a small area---NOT THE CLETRAC WAY---so the man sinks through.



Not the Cletrac Way



The Cletrac Way

With the snow shoes the weight is distributed evenly over a larger area---THE CLETRAC WAY---and the man glides over the surface.

# Share Cletrac Profits

THE Cletrac will pay dividends to thousands of Canadian farmers this season. There will be a lot of Cletrac dividends to divide among dealers, too. You are overlooking the "one best bet" if you are not arranging to get your share of these dividends.

Wherever a tractor of any sort can be sold, the Cletrac can be sold. Big farms or little farms, rough land or level, wet land, sandy land—they all look alike to the Cletrac. With the Cletrac Agency, no tractor prospect need be passed up.

The Cletrac does more kinds of work and works more days each year—you will find sale for the

Cletrac more days in the year, too. Start selling now. Get right in the lead with the Cletrac.

If there was ever a tractor that could get by without advertising, it is a Cletrac—it has so many exclusive good features. But the Cletrac is backed by one of the most effective advertising campaigns that has ever helped dealers to easier tractor sales.

Many farmers already know about Cletrac handiness; that it burns cheap coal oil, (kerosene); that it is the **Tank-Type** that carries, lays down and travels on its own tracks. All farmers will know about these before the season ends.

*Get a Cletrac contract. Get Cletrac literature. Study up on the Cletrac and get your full share of Cletrac profits.*

**The Cleveland Tractor Company  
of Canada Limited**

HEAD OFFICE  
WINDSOR ONTARIO

WESTERN SALES BRANCH  
REGINA, SASK.



# Sell These John Deere Implements NOW. In- crease Your Income.

Everywhere farmers are showing a preference for John Deere implements. Dealers, too, are enthusiastic. The John Deere sales policy enables dealers to get the utmost out of their investment and their sales ability. This is a decidedly profitable combination—John Deere quality and the liberal sales policy. Make **your** arrangements now.

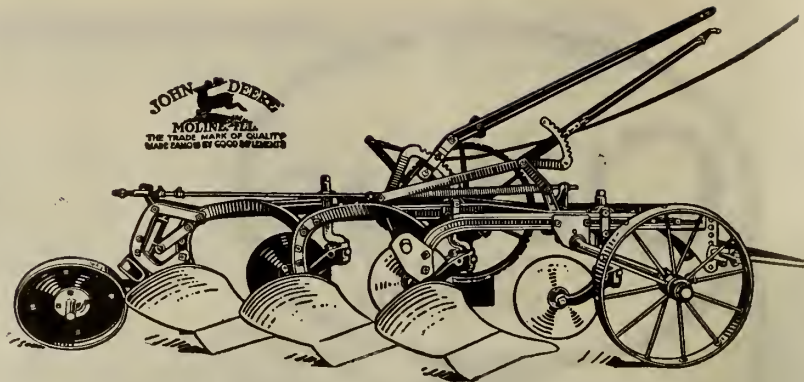

John Deere No. 5 Tractor Plow—3 Bottom

## John Deere No. 5 Tractor Plow

This year farmers want extra good seed beds. They want to speed up production. They want big yields and big profits. The John Deere No. 5 Tractor Plow—2 or 3 bottoms—will enable them to get best results.

It has Quick, Detachable Shares. Bottoms enter ground quickly and wear, scour and pulverize to best

advantage. It holds to its work at uniform depth. Extra heavy beams of special John Deere steel—**guaranteed** not to bend or break. It lasts longer and does better work. Hitch is adjustable for any size tractor. Farm paper advertising is interesting farmers in this tractor plow—the farmers in your vicinity will hear about it. Co-operate!

## John Deere Stiff Tooth Cultivator

Consider these features of the John Deere J.B. Level Lift Cultivator for instance. Easily adjusted to cultivate rows from 28 inches to 48 inches apart — has a handy spacing lever that farmers like. The wheels are easily set for close or wide tread. Farmers can guide the rigs by slight pressure on convenient pedals.

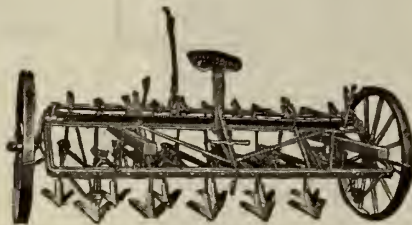

The shovels always face squarely to their work—no tracking or trailing. Uniform cultivation is the result. The lift of the rigs is nearly automatic. The farmer simply unlatches the master lever—gives a slight pull and up go the rigs high and level—front and rear shovels having a high clearance.

All levers are within convenient reach. All adjustments are made from the seat. Close hitch and direct pull—it's a light draft cultivator. We can furnish a two-row attachment that can be put on in about 10 minutes. Doubles the cultivating capacity. Easy to operate. It is easy to sell John Deere Cultivators.

## John Deere Syracuse Spring Tooth Harrow

It can be used on all kinds of land. It pulverizes better—the spring teeth penetrate to a greater depth, dig up the under soil and mix it with the top soil.

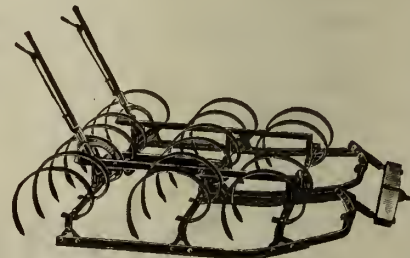

Note the frame between the sections—it has a small opening in front which widens toward the rear. There can be no loading or choking at this point.

The teeth are spaced so that all trash works toward the center and out through the opening. Teeth are instantly adjusted. Just demonstrate this harrow to farmers on sandy, gravelly or stony ground. It will sell on demonstration.

### Sell These Quality Implement

- |  |  |
|--|--|
| John Deere Low Down Manure Spreader            | John Deere-Dain System Left Hand Side-delivery Rake  |
| John Deere-Van Brunt Grain Drill               | John Deere-Dain Hay Loader                           |
| John Deere-Van Brunt Fertilizer Drill          | John Deere One-horse Steel Cultivators               |
| John Deere-Van Brunt Lime and Fertilizer Sower | John Deere Syracuse Spring Tooth Harrows             |
| Hoover Potato Diggers                          | John Deere Corn Planter                              |
| Hoover Potato Planters                         | John Deere Cultivator                                |
| Hoover Potato Cutters                          | John Deere Beet Tools                                |
| John Deere Scufflers                           | John Deere Syracuse Plows—(Riding, Tractor, Walking) |

# John Deere Manufacturing Company, Limited

Welland - Ontario





## The Sales Possibilities for Power and Light Plants, and Necessary Equipment

**T**HE hour is ripe for the farmer market. The tremendous buying power of the farmer and rural dweller is waiting for aggressive men to develop.

As far as farm lighting and power plant sales are concerned, the market has hardly been touched. The automobile demonstrates what can be done, and what kind of a buyer the farmer is.

In two decades, automobile sales in Canada have exceeded \$450,000,000. How much has the farmer contributed to these enormous figures? In Ontario 65,000 cars are owned outside of cities; in Quebec and the Maritime Provinces 60% are owned outside of cities, and in the Prairie Provinces nearly 80% are owned by the rural population.

The market for power and light plants in rural districts is potentially as great as the number of automobiles now owned in those districts. Like the automobile, the power and light plant is a necessity to the farmer and rural dweller, because it means greater comfort, convenience and economy, and labor saving. The shortage of farm labor has forced the farmer to depend more and more upon labor saving equipment.

That the farmer needs power and electric light plants is evident by the growth of hydro service in those parts of the country which are served by the great transmission lines. Thousands of inquiries for hydro service

have been made in Ontario, the greater portion of which cannot be supplied.

In the Prairie Provinces over 11,000 self-contained electric light plants have been sold. In Ontario 2,130 plants have been installed, of which number 25% have been sold during the last twelve months alone.

These rural dwellers have learned that better equipment produces better returns.

Great as is the profit to be made from the sale of "F" Power and Light Plants, still more money will be made from their installation and the sale of equipment, such as electric washing machines, churns, vacuum cleaners, irons, cream separators, water pumps and water systems, which will more than double the sales possibilities of the plants themselves.

The sale of Fairbanks-Morse "F" Power and Light Plants will run into millions of dollars for those men who are awake to the possibilities of this business.

### AGENTS WANTED

Exclusive territories for this agency are now being allotted. If you want to make money, and make it faster than you have ever made it before, send the Dealer's coupon inside this insert, with your letter-head, to our nearest branch, asking that your territory be reserved for you.



## The Canadian Fairbanks-Morse Co., Limited

HALIFAX    ST. JOHN    QUEBEC    MONTREAL    OTTAWA    TORONTO    HAMILTON  
WINDSOR    WINNIPEG    SASKATOON    REGINA    CALGARY  
VANCOUVER    VICTORIA



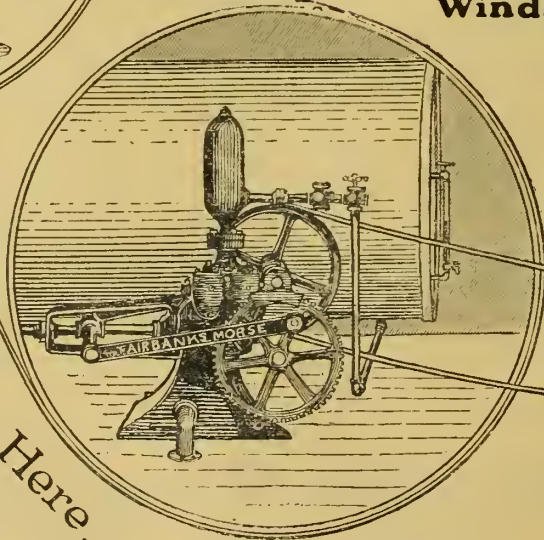
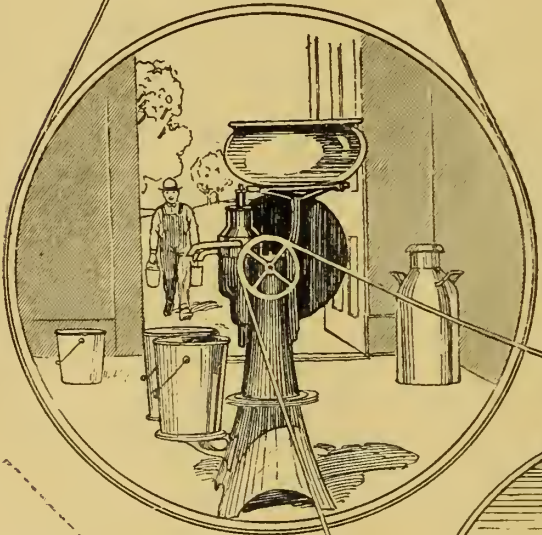
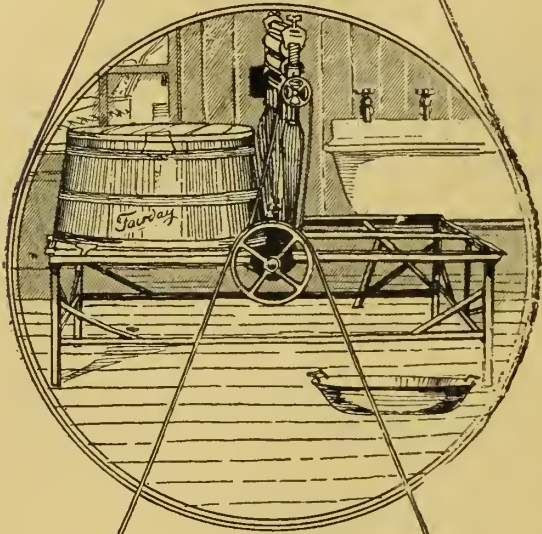
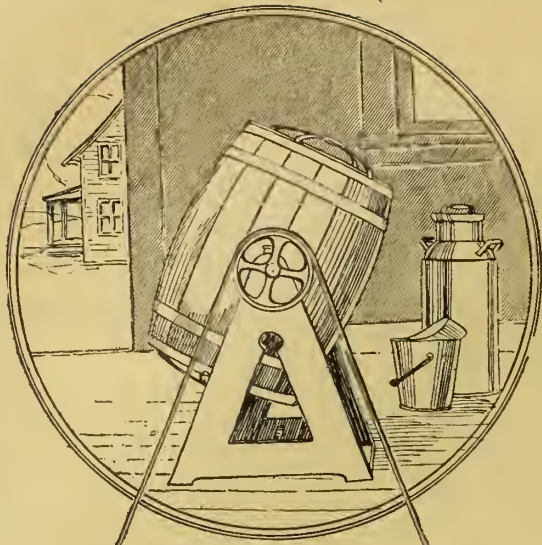

# If You Want Greater Comfort Install a Fairbanks "F" Power and Light Plant

**I**N a short time you will find that this plant is the biggest thing on your farm. Big in value, in comparison with the purchase price—big in the amount of drudgery it saves you—big in its labor-saving for your wife—big in its convenience—big in its comfort—big in its economy.

It is a separate unit plant, driven by the famous "Z" Engine, which more than 250,000 farmers are using. It permits of the greatest possible saving in power, because you can utilize the full power of the engine to drive other machinery by simply unbelting the generator and driving direct from the engine, thereby saving the 50% power loss caused by driving machinery with motors.

And you can, if you wish, drive another machine while you are charging your batteries.

It is so simple that any boy can run it. There are no costly,

## Agents

We need good live agents in every section. Clip coupon on the left corner and send it for full particulars of the biggest and

## The Canadian Fairbanks-Morse

- |                 |                  |
|-----------------|------------------|
| <b>Montreal</b> | <b>Quebec</b>    |
| <b>St. John</b> | <b>Ottawa</b>    |
| <b>Toronto</b>  | <b>Hamilton</b>  |
| <b>Windsor</b>  | <b>Winnipeg</b>  |
|                 | <b>Regina</b>    |
|                 | <b>Saskatoon</b> |
|                 | <b>Calgary</b>   |
|                 | <b>Vancouver</b> |
|                 | <b>Victoria</b>  |

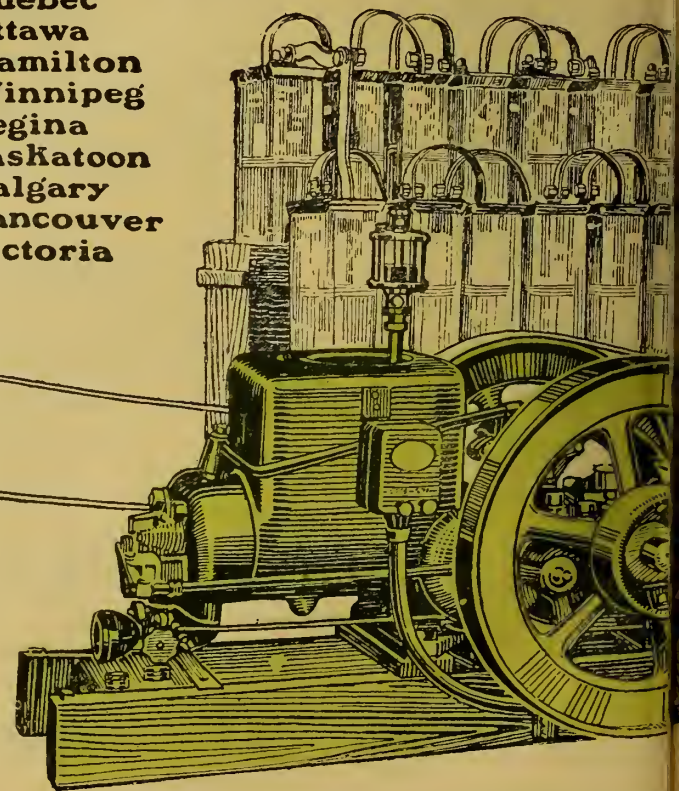

**Clip Coupon Here**  
**DEALER'S COUPON**  
 Fill in this coupon and enclose it with your letter-head and mail to our nearest branch for full particulars of Fairbanks-Morse "F" power and Light Plant Agency.  
 Name.....  
 Address.....



# Efficiency, and Economy, Fairbanks-Morse Light Plant

licate parts to get out of order, and it requires little attention and  
eldom needs adjustment or repairs.

It is strong, sturdy and the most efficient Power and Light Plant  
made. It has ample power to drive a churn, separator, pump, washing  
machine, etc., direct from the engine or from a line shaft, and it will  
furnish a flood of clean, brilliant light in your house and other build-  
ings, whenever you push the button. It also furnishes current for  
vacuum cleaner, electric iron, toaster, coffee percolator, etc., and  
there are no smelly lamps to fill and clean, and no danger of fire.

Thousands of farmers and rural residents will soon be equipped  
with a "F" Power and Light Plant, because it saves labor, time, worry  
and enough money to pay for itself. Clip the coupon on the right  
corner and send it to our nearest branch for full information. It  
places you under no obligation.

## Wanted

every city and district in Canada. Clip the  
coupon on your letterhead, to our nearest office  
for the best selling proposition on the market.

## Fairbanks-Morse Co. Limited

### 40-LIGHT PLANT

### \$495.00 F.O.B. Toronto

Also made in  
65, 100 and  
200-light sizes



Clip Coupon Here

USER'S COUPON  
Canadian Fairbanks-Morse Co. Limited  
Tell me, without obligation, the advantages  
of Fairbanks-Morse Power and Light  
Plant.  
Name \_\_\_\_\_  
Address \_\_\_\_\_



# OPPORTUNITY

## The Greatest Money-making Agency in Canada



Wherever there is an oil lamp on a farm there is an opportunity for a lighting plant sale.

WE want at once, aggressive representatives in every section of Canada to handle the "F" Power & Light Plant Agency. The market for farm lighting and power plants is second only to the automobile field—we know that to be true because we have made a thorough investigation of the rural market in every province.

To supply the number of plants which can be sold *now*, were every district in the country in the hands of aggressive agents, would take the Fairbanks-Morse factories several years, running day and night.

The Fairbanks-Morse "F" Power and Light Plant fills the requirements of this immense market. We know it to be the lowest-priced plant made—we know it is the most flexible and economical in operation, and we know it is the most efficient plant ever constructed.

Behind this superior equipment stands The Canadian Fairbanks-Morse Co., Limited, with an intensive plan of co-operation, through which you cannot help selling the "F" Power and Light Plant.

### THE DOMINATING ADVERTISING CAMPAIGN FOR 1920

will blanket practically every prospective buyer of a farm lighting system in Canada, and every inquiry which it produces will be turned over at once to our agencies to follow up for sales.

The representatives selected to fit into this organization, to cash-in on such a tremendous money-making proposition as the selling and installation of our "F" Power and Light Plant, must have known responsibility and be willing to work the territory as it has never been worked before.

Each agent must make it his business to see that every plant is properly installed, and he must be able to render service to those to whom he sells. He need not be a practical electrician himself, but he should be able to hire one, or form a working connection with one already established.

He must invest in a plant for demonstration purposes, for we know *this is the one successful way* to sell lighting plants. People insist on being shown before they buy.

He must realize the great possibilities each installation offers for selling other electrical equipment; he must be capable of handling a business which will make his bank account grow by thousands of dollars each year.

If you mean business, fill in the Dealer's coupon inside this insert now, with your letter-head, and send it to our Branch nearest you.



The Canadian Fairbanks-Morse Co., Limited

HALIFAX

ST. JOHN

QUEBEC

MONTREAL

OTTAWA

TORONTO

HAMILTON

WINDSOR

WINNIPEG

SASKATOON

REGINA

CALGARY

VANCOUVER

VICTORIA



# CANADIAN MOTOR, TRACTOR AND IMPLEMENT TRADE JOURNAL

Volume 2

TORONTO, FEBRUARY 5, 1920

Number 2

*Pull Together—Not Separately*

## Dealers' Organizations Should Be:

CORRECTIVE—CONSTRUCTIVE—PROTECTIVE



**T**HE purpose of this article on "Trade Associations" and "Get-Together Meetings" is to try and show their usefulness. Many dealers are already convinced of the value of the idea, and it is hoped that the suggestions described herein will prove helpful to others.

A Trade Association is the application to your business of the principle "In union there is strength," "Two heads are better than one." Two or more horses pulling together will get somewhere; 20 horses pulling in different directions will not. The principle of organization was convincingly evidenced in the various war activities, and we have all been astonished at the wonderful results obtained—for example, the Red Cross and Victory Loan drives. In co-operation

with others in your own line of business you get access to those business methods which somebody else has found contributed to his success and growth, and you can with greater certainty apply these new methods to your own particular business.

Organization should be *corrective, constructive and protective*. Your association should seek to correct unfavorable conditions; then strive to set in motion *constructive* policies; then study to *protect* what it has done.

An association can accomplish that which an individual might not be able to do—such as correcting unfavorable sales and financial policies of the motor car, truck, tractor and tire factories; taking up with the factories the matter of national advertising of the lines of goods you handle; also any unsatisfactory methods of your wholesale jobber in automotive equipment. A good opportunity is given to you as a member to remedy by suggestion and example any incorrect practices of your local competitors. Your association may set out to get favorable publicity in general for the members and prevent "fake" advertising. By pooling advertising funds and carrying on a good, constructive advertising campaign you may obtain that which no one member could afford to carry on alone. Such advertising can carry the name of all dealers who contribute and this will often help to get small dealers to join the association when other methods of persuasion fail. If the members get down and keep down to the real business of doing something constructive for the general good of the industry in their community most of the price-cutting squabbles and petty jealousies will fade away.

By **CECIL DIXON**

(Now on M.T.I. Staff; until Jan. 1, 1920, with Hyslop Bros.)

**A**T THESE "Get-Together" meetings a programme should be prepared by the chairman that will produce discussions on how to eliminate wasteful methods; comparison of office methods or system of records; promotion of road and highway improvements; better trade methods; and assist by education and conference the status of any dealer who may have recent-

prices, which injures his business as well as the industry as a whole. Through the medium of your association you will often find that some other members in a *different locality* can use your overstock.

Another point, and that is, if you are now a member of a local or Provincial trade association, do not expect that it is going to show 100 per cent. results immediately. None of us is perfect. There is a lot of work for an organization to do, and until every dealer gets behind the industry as a whole the result will be under 100 per cent. Attendance at every meeting is absolutely necessary and all must take part in the proceedings.

You can be absolutely certain of this: That *you* will be successful only insofar as *the industry* in which you are engaged is successful. You and every dealer ought to and must do his part—to put the industry as a whole on the soundest possible basis, and this you can accomplish to a high degree by co-operation through a trade association.



**THAT MOTOR TRUCK DEAL!**  
Hon. E. C. Drury: "There goes in this one spill five years' savings of that \$3,000 cut in my salary."  
—From Toronto "Telegram."

ly started in the business and who from inexperience may fall into some of the pitfalls and ruin his business as well as destroy a portion of your own. A discussion along the lines of the cost of doing business will always be helpful and usually cure any price-cutting habits. Cut prices are resorted to in most cases through ignorance of the cost of doing business. If overstocked on any line it is far better for the dealer to try and dispose of the surplus stock to his competitors *at cost* rather than indulge in ruinous cut

### "Owl" Truck Service

**V**ICTORIA, B.C.—The motor truck has become so vital to the daily carrying of Victoria's business that operators are put to a serious inconvenience when even one machine is laid up for a day or a part of a day.

This situation has called into existence a service station that takes a sick truck after the day's work is over, and before daylight next morning turns it out whole and sound as long as the ailment is something that can be remedied by an expert mechanical staff within sixteen hours. Of course if the work takes longer than sixteen hours it can be carried on during the following day, and in the end the owner of the truck will be sixteen hours ahead in getting his truck on the road again.

The men responsible for this innovation in the motor service business of Victoria are Harry Cook and Bill Mason, who are operating the Acme Auto Repair Service Station at 741 Fisgard Street.

This "owl" repair service, business firms who are using it say, is saving them much money, especially when all their trucks are working to capacity during the day and the laying off of one truck means a serious dislocation of their whole delivery service.

Because of the "owl" service these two men have handed over to them the entire mechanical supervision and regular inspection of several of the largest fleets of delivery trucks in Victoria. By the service the trucks are always kept on the road, and in their maximum state of efficiency.

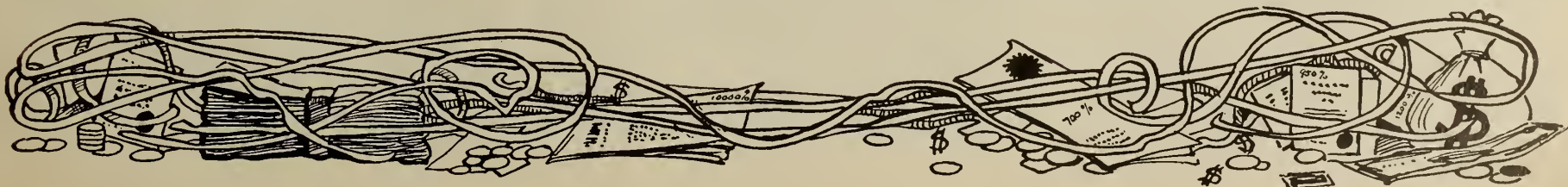



# BUG-BEAR of Implement Business

## Don't Trade New Implements for Old, Says M. Clow

FOR some reason or other a university education and the selling of agricultural implements are not usually linked up with each other — though why this should continue to be so in these days of modern merchandising we do not know.

Last month it was announced that Fred M. Clow, implement dealer, of Kingston, Ontario, had been elected an alderman of the city, and we promised to tell the story of his success — that is to say, his implement success, not his aldermanic. In his first few sentences Alderman Clow revealed the reason for his success in both "games." He enjoys selling implements, and he enjoys politics, and being as good a mixer as he is business man, he puts both across effectively.

"If I had to start life over again, I would take advantage of a university education, and then sell implements," said Mr. Clow. "I had a public school and high school education, but will always regret I didn't have the advantages a university course offers."

Mr. Clow loves the implement business and thinks it is the greatest in the world. As the foregoing will show, he thinks a man can't be too well educated to sell farm machinery. Continuing, he says:

"I always intended to become an implement dealer. I think it must have been bred in me. I was born on a farm, and when old enough worked on one; then for years my father has been selling horse trucks, cutters, buggies, stable fittings, etc. So you see I come by my love for the business honestly.

"I am convinced that in order to succeed in this business a man must be enthusiastic, sincere, honest, and a hard worker. He should love work for its own sake. He should not be hide-bound to any method, but be able to step easily from an old principle to a new one.

"I BROKE in on the implement field four years ago, full of hope, enthusiasm and schemes. For the first two years it was very much of an up-hill grind. I went down considerably, but I am pleased to say in the past two years I have been able to pull ahead.

"On my trips around the country I have learned many things. It wasn't long before I learned the value of honest dealing. It happened this way:

"I heard of a man one day who wanted to buy an engine, so decided to call on him. When I got out to his farm I found I was too late, as he had already bought one from another dealer. However, in course of conversation he said that he didn't like the engine he had bought and was going to try and get the dealer to take it back.

"Some weeks later I met him again and enquired how he made out. He informed me that the dealer refused to take the engine back unless he would consent to buy some other article. The farmer was furious; but, as he didn't want the engine at any price he decided to take the articles.

"Thinking the moment opportune I immediately tried to sell him one of my engines. The farmer, still smarting under his last deal, refused to consider the matter, and said:

"'You agents are all alike; you will say anything to get an order, and don't know the first principles of honest dealing.'



This picture shows F. M. Clow's premises at Kingston. The man on the left wearing a straw hat is Mr. Clow; his father is in the centre. Mr. Clow plans to extend his premises shortly.

"THAT WAS a pretty stiff blow, straight from the shoulder. However, I stuck to my guns and told him I would send him an engine and put it in on a sixty-day trial; and if at the end of that time it didn't prove to his satisfaction, I would take it out and it wouldn't cost him a cent.

"I got him to sign an order to that effect, and the engine was delivered and set up for him. He had the engine only a few days when he 'phoned me, saying he could not start it. I at once drove out to his place — six miles — and found his only trouble was flooding. I took pains to show him how to avoid a repetition of his trouble and he remarked:

"I believe you are honest and want to do what is right."

"He then asked me if I would arrange a time to come out and start the engine on his saw, as he wanted to cut up his Summer supply of wood. A time was set, and I went out and stayed with him about two hours, until his engine and saw were working in good shape. In less than sixty days he came to me and said he wanted to pay for his engine. After I had given him a receipt and thanked him he put his hand out, saying:

"I have found one dealer who is trying to do business with the farmer as it should be done; and, believe me, there never will be anything bought on my farm that doesn't come from you; and just so long as you do business in that manner you will have my hearty support."

"That principle is the keynote of my success. I put great stress on service and fair dealing. It has always been my policy to handle nothing but the best kinds of implements, manufactured by reliable firms. I don't try so much to make a sale as to sell my goods to a contented customer.

"I never sell a man an article for which he has little or no use. If I did it would surely come back on me, and one day would drive me into that 'limbo' where all dishonest merchants go.

"Service, it seems to me, plays a dominant part in selling farm machinery.

"One of my customers, to whom I had sold a milking machine, 'phoned in one night in a great rage, saying that his milking machine wouldn't work. I got up at 3 o'clock next morning and rode out to his farm. When I got there I found that his machine was dirty and only required to be properly cleaned. I stayed all day until I had it in working shape again. The farmer was so pleased that before I left he gave me an order for some more goods.

"The question as to what service should be given free, and what should be charged, doesn't worry me

a bit. I give all service necessary and find, in almost every case, by doing the best I can for my prospects, that more business comes my way.

"THE farmer is a hard man to sell; the hardest in the world. Oftentimes he wants to trade an old tool for a new one. To my mind this kind of trading is the bugbear of the implement business.

"I attribute my loss in the first two seasons to this cause alone. It pulls down your profits, and loads you up with a lot of useless junk. Why should a farmer expect an implement dealer to take an old drill, say, as part payment on a separator, any more than a tailor should take an old suit as part payment on a new one?"

"I am against such trading. It is a Gipsy business which

should be opposed by all implement men. "I believe if we had dealer's association in each Province, it would be possible to grapple with this unfair trading. Such an association could help considerably, by excluding from its membership all dealers who practised trading; and, again, by impressing on the manufacturers, the advantage of looking to the members of the said association, for dealers in the various territories. This, to my mind, would go a long way to solve the problem."

Mr. Clow, as the foregoing will show, is a wide-awake young man. He has ideas, and watches the trend of things. He makes friends with everybody and goes everywhere. Even the school children all know his little Ford car, with the small lorry attachment for carrying goods out to his prospects.

If he should be passing the country school-house when the children are coming out, he invites as many as can get on to his "bus" to "come on," and drives them towards their homes.

His store has an excellent location on the Kingston Road. He shares it with his father—who is still selling buggies and cutters. Most of the farmers, when coming in to the market, have to pass his way, and many additional sales are thus made.

Mr. Clow showed rare business ability when he got the tax collector for the township of Kingston to receive the farmers' taxes in his store. This brings a lot of business during the Christmas season, as all the farmers on their way to town stop off on certain Saturdays to pay their taxes.

When the M.T.I. representative saw Mr. Clow, it was on such a Saturday morning, and as the collector was an hour or so late in coming, the store was filled with farmers.

When we left Mr. Clow had sold some separator supplies, and had contracted to do some repairs; and was negotiating with a farmer for the sale of a cutter. That is one way to bring prospects through your door.

Mr. Clow believes in a cash business. If there are any discounts going, he also advises his prospects to buy for cash and points out where they gain by doing so.

He is arranging with one of his manufacturers to get out large signs, four feet long, by two feet wide, for advertising purposes. These will be placed on the main roads of the city, and at important crossings. The manufacturers are paying half of the cost of making and installing the signs. He is also working on small posters of his own and will distribute them around his territory.



# Palms, Shrubs, Feature Truck Show-Room

*British Columbia Displays Garfords In  
Exotic Surroundings*



**I**F THERE is any word in the automotive world to-day which is being over-worked it is — Service.

Yet, properly applied, there is no word which *should* be worked harder, and no word, or act, more productive of results. The manufacturer, whether it be of motors, trucks, vacuum cleaners, or fountain pens, who can give adequate service is the man whose product will win out every time.

What product will you find at the top of the industrial heap? Why, the product which is built right in the first place, and kept right ever afterward.

The service given by the manufacturers, distributors and dealers to purchasers of the Garford truck is so extensive, so efficient, and so unusual in its completeness that we believe readers of M. T. I. will be interested in the details.

The Garford truck is manufactured in and is distributed in British Columbia by the Motor Service, Limited, 1105 Granville Street, Vancouver. New show rooms and service station have been opened within the past few weeks, and they embody all the most up-to-date ideas. It is only in the largest dealers' show rooms in the United States and Canada that palm trees, flowers and shrubs are used to create pleasant surroundings for prospective customers. But in the Garford Vancouver show rooms masses of flowers and shrubs are used in profusion to beautify the truck show rooms. Some class!

**T**HE OFFICES at the rear are commodious and provide for greater expansion of the organization. The service department, still further in the rear, is thoroughly equipped and is manned by Garford experts. Above this department is located the "spare" room, which is one of the most important items in the building. Here is kept a complete stock of all Garford parts, thus ensuring quick service.

George A. Sabourin, the head of Motor Service, Limited, is a truck man of many years' practical experience in the United States and British Columbia. He is supported by a trained staff, always ready to give not only mechanical service, but also ready and able to advise business men frankly regarding their haulage problems.

The M. T. I. asked Mr. Sabourin to go into his service problem in detail, and he states:

"Motor Service, Limited, works in co-operation with the Garford factory with the purpose of giving the best service on Garford trucks. Through its extensive organization the Garford Company retains a direct service-interest in every Garford truck in operation. This organization embraces its branches, its distributors, its dealers, a corps of travelling inspectors and the facilities of the factory.

"A corps of travelling inspectors is maintained to assure a high degree of service. It is the duty of these trained experts to inspect three or four times each year every Garford truck. They stand ready at all times to co-operate with distributors and dealers

and their staffs, and to aid them in rendering maximum service to users.

"Motor Service, Limited, makes a monthly inspection of all trucks. Each truck is therefore inspected about twelve times per year by us and four times per annum by travelling inspectors. An inspection sheet is made out each time, a copy going to the factory, one to the distributor and one to the customer. These inspections are of great benefit to the user, and last, but not least, to the factory. The factory is able, by reference to these service sheets, immediately to detect any weak points, and immediately correct them. The result is that the Garford Company will continue to make better and better trucks.

"**T**HE PRINCIPLE behind all this service is to keep Garfords continuously in operation. As a part of this service, we carry a complete stock of spare parts. The inspection, however, seems to eliminate to a large extent all call for spare parts."

Motor Service, Limited, also distributes the Columbia Six in British Columbia, and carries out its truck service ideas in regard to this line also, insisting that all Columbia Six owners bring their cars in for inspection at least once a month.

## Movie Publicity for Accessory Dealer

By F. H. SWEET

**T**HERE are many ways in which the enterprising accessories dealer can keep his name before a given community, but probably none of them offers the possibilities that intelligent movie slides do. Advertising depends on several things in order to be successful. In the first place, your advertisement must be seen and it must be so worded or arranged that it attracts attention. This the movie slide will do in a way that cannot be approached in any other fashion.

Slides are used in the moving picture theatre for a definite purpose, namely, as fillers to divert the attention of the audience while reels are being changed or the orchestra given a rest. People do not object to them, provided there are not too many, as they prefer watching the screen to sitting in dreary idleness. Not only that, but people sitting in a darkened theatre will be forced to see your advertisement whether they are willing or not. Such is not always the case with other mediums. By a careful selection of the localities in which you are particularly anxious to build up business, you can cultivate that field in no better than by having attractive movie slides made and used in the progressive movies of that section. But much care is needed in selecting the proper shows in which to advertise.

There are undesirable shows just as there are undesirable newspapers and magazines. Then, again, some operators are very lax in taking care of slides.

They allow them to become dirty, cracked and soiled or fail to run them for days at a time. Such practices will not bring the desired results any more than a newspaper that runs your advertisement every once in a while would. Men who follow such courses should, of course, be avoided.

**T**HERE are theatres also to be avoided. Because of the very class of patrons and films to which they cater, they are undesirable mediums for the accessories dealer to use. It is only the modern theatre in the best districts that should be cultivated to any extent.

The designing and wording of the slide must be as carefully worked out as the best magazine or newspaper advertisement. It should convey a message that will get across quickly. There should be little wording on it. The appeal should be through a picture rather than through wordy reasoning.

Remember that people in a movie theatre are there to be amused before they are to be instructed or induced to do anything else. Do not antagonize them by wordy advertisements in small type. If you have any new or attractive accessory or article you wish to bring before the public, show a picture of it. If you are making a specialty of something, show it up, with appropriate surroundings or things that go with it—whether a car, tractor, various accessories, or standard hardware. The most prominent thing in a movie slide, outside of the lesson you are trying to get across in your picture, is your firm's name. It should be in large type, easy to read—above all, your street number or 'phone number.

Slides may be had to cost almost any price. They run as low as thirty-five to fifty cents each for stock slides, on up to almost any price you care to pay. While this is usually a small initial cost, the real matter of expense comes in the rate charged by the theatre manager to run your slide.

Theatre rates are almost wholly made up on the basis of monthly showing. This means that your slide will be shown upon the screen an average of three to five times a day, between every change of program. Managers generally have their own ideas as to the value of such service, basing it sometimes upon guesswork, but more often upon some definite basis of calculation, such as an estimate of the daily attendance throughout an average month.

**R**ATES will vary according to the character of the advertisement, usually running from \$5 up to as high as \$50 per month in some of the more exclusive theatres.

The possibilities of movie advertising have, as yet, only been slightly touched. They will become more and more a factor of accessories, repair parts, and of general hardware, in the future. One of the best appeals that a dealer can use in this class of advertising is the appeal to the beautiful.



# CANADIAN MOTOR, TRACTOR AND IMPLEMENT TRADE JOURNAL

Published on the fifth of each month by

The MacLean Publishing Co., Limited  
TORONTO, MONTREAL, WINNIPEG

JOHN BAYNE MACLEAN, President. H. T. HUNTER, Vice-President.

H. V. TYRRELL, General Manager.

LONDON, ENG., THE MACLEAN COMPANY, OF GREAT BRITAIN, LTD., 88 FLEET STREET, E.C.

BRANCH OFFICES: Montreal, Southam Building, 128 Bleury Street; Winnipeg, 1103 Union Trust Building; Vancouver, 89 Tenth Ave. West; New York, Room 620, 111 Broadway; Chicago, 1401 Lytton Bldg.; Boston, 784 Old South Building.

SUBSCRIPTION PRICE—\$1.00 A YEAR.

OFFICE OF PUBLICATION—143-153 University Ave., Toronto.

Vol. II. TORONTO, FEB. 5, 1920 No. 2

## ALL-CANADA ISSUE

THIS is the twelfth number of M. T. I. We started with 50 paid-in-advance subscribers and with a 32-page issue. With this issue we have more than 3,000 subscribers, and as you will notice there are 60 pages in this issue. You may also be interested to note that this is a truly national medium, as there are articles and news items from every section of Canada; there are one or more from the Maritimes, Quebec, Ontario, Manitoba, Saskatchewan, Alberta and B.C. Truly Canadian and representative of All Canada.

## WHAT WOULD YOU DO?

IF YOU were an implement dealer, and closed a sale for a power-lift sulky plow;

And you made the delivery, giving the farmer the two extra shares that go with the machine;

And the farmer came into your office a few days later, asking for two shares, claiming that he had never received the two shares sent out to him;

What would you do?

This is the problem that was put up to an Eastern Ontario implement dealer a short time ago. He tried to explain, but no use; the farmer raged, and threatened never to do any more business with that dealer unless he immediately was handed over two shares.

The dealer knew the shares had been delivered; he was as morally certain as we humans can be that the farmer had received the shares, and was merely trying to be what he thought "smooth" and gouge the dealer for two more.

What would you do? Would you give him the shares?

This dealer did. But it looks to us like this:

Ever afterwards the farmer—and perhaps other farmers—will play this dealer for an "easy mark."

If he can "get away with it" once, why not again?

Besides, it's encouraging dishonesty.

Now, honestly, what would you do?

## "I SHOULD WORRY"—A FAILURE SLOGAN

MENTAL attitude has everything to do with progress—success—retrogression—failure! The "I should worry" point of view of thousands of tractor dealers, and potential tractor dealers, has lurking in it a composite danger beyond computation, and, to say the least, is a commercial death-knell if not quickly overcome by a change of mind upon the part of those guilty of possessing this alarming guide-thought.

"I should worry" is the slogan of the dealer who fervently demands everything and shirks every responsibility possible.

The "I should worry" thought is father to slow sales methods, lack of adequate service, proper representation of lines carried, and short-measure performance. The tractor industry can not progress speedily with her dealers assuming the "I should worry" attitude.

Every dealer has his important place in the plan of the tractor industry's great future, and his office is not that of a stumbling block.

Laggards, time-stealers, and followers of easy ways, have no place in the economics of the great tractor industry.—Exchange.

## \$15,000 TRUCK BOUQUET

WHEN a New York truck dealer sells \$100,000 worth of trucks, he feels pleased with life, and ready to blow some of his 12 per cent., 15 per cent., or 18 per cent., as the case may be, in a Gotham lobster palace. When a Montreal or Toronto dealer closes a deal like this, he can justly pat himself on the back, and feel that he has come pretty close to a record, and maybe can afford even to buy tickets for himself and wife and a friend or two at the King Edward Hotel, New Year's Eve blow-out—at \$7.50 per each.

But, what do you think when an auto dealer in a town of 5,000—Dundas, Ontario, to wit—puts across a \$100,000 truck deal? Pipe-dream? Not on your life;

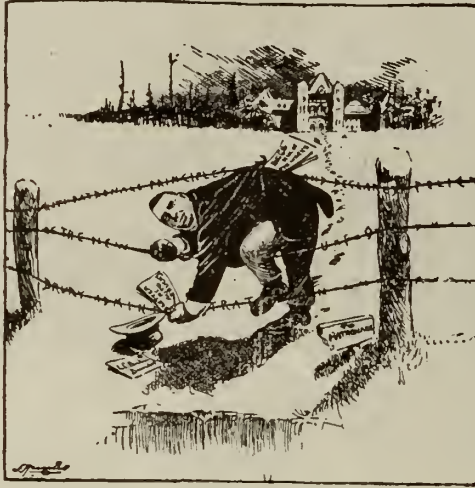

Hunter, in Toronto "World."  
"Who said 'Trespassing'?"

that's what was done one day last month by Len Parkin, auto dealer, who sold \$100,000 worth of Sterling trucks to Hon. F. C. Biggs, Minister of Public Works for Ontario, with commission said to be 15 per cent. On this deal, the *Toronto Mail and Empire* says:

"Hon. F. C. Biggs, Minister of Public Works for Ontario, is receiving more publicity than he hoped for by reason of the order for nearly \$100,000 worth of motor trucks of United States manufacture placed with Len Parkin, a Dundas dealer, who lives in Mr. Biggs' riding. The usual procedure of the department had been followed, he said, and he simply o.k.'d the order on the recommendation of the two chief engineers for the Works Department. Other tenders for trucks had been received by the department, he said, following invitations to dealers to submit figures. This was the only one to tender on the particular make of trucks desired by the department. The Dundas order for ten trucks, he said, was only the first of a number of orders for trucks for highway construction and the dealers would have a chance to tender. It had not been the custom of the Public Works Department to advertise for tenders for equipment, but to order in this way. In connection with the matter, D. G. Bawtinsheimer, National truck



"Farm Implement News."  
Are YOU passing up any chances?

dealer of Dundas, to-day denies the report that he stated that the \$100,000 truck order was handed to a Dundas garage man on a silver platter by the Minister of Public Works."

## BEWARE WORKING IN CLOSED GARAGES

DID you ever stop to realize that working in a small, closed garage with the engine of your car running is like gambling with death? The newspapers have reported several cases of persons collapsing and perishing under such circumstances before aid could reach them. This should serve as a warning to all car owners. Unfortunately it is easy to forget the warning on a cold winter day when you are pottering around the car and have closed the door and windows of the garage, and have started the engine running, perhaps to secure a little heat from the muffler and radiator.

There is no mystery about the cause of disaster lurking in the closed garage. It is the deadly gas carbon monoxide which is mixed with the exhaust gases from the engine. Even small quantities are disastrous; in fact, this gas formed the principal constituent of one of the worst of the poison gases used in the war.

The U.S. Bureau of Mines recently issued a technical paper dealing with the vitiation of garage air, in which it was stated that air containing as little as one-fifth of one per cent. of carbon monoxide will cause a man at rest to collapse within an hour. Experiments made to determine to what degree air in a closed garage is vitiated by running a four-cylinder engine of 30 horsepower, proved the presence of dangerous proportions of carbon monoxide in the most distant parts of the garage after running the engine less than a half hour, while near the exhaust muffler the air was extremely unsafe after the engine had run 15 minutes. These results were secured with various settings of the throttle and spark.

The worst feature of carbon monoxide poisoning is that there are likely to be no symptoms to serve as a warning. Collapse comes suddenly, while the running engine is constantly making the air still more poisonous; hence everything is in favor of the victim perishing before help could arrive.

Always open the doors and windows of your garage before starting your engine, or better still, take the car out into the open and you will thereby avoid exposing yourself to a very real danger.

## GOOD AND BAD ADS

IF YOU write a good ad. for your local paper—one that has style, snap, vigor and an unusual twist to it—one that you're really quite pleased with—send a copy to the Editor of M. T. I. We must confess we notice very few really good ads. in looking over Canadian dailies and weeklies occasionally. Maybe the good ones slip past our notice.

So, whether you sell autos, tractors, implements, accessories, or household and dairy supplies, let us see what it looks like in print. Also, if you want our advice re your advertising writing any time, don't feel bashful about it. Drop the M. T. I. a line, outlining your desires and problems, and the resources of our entire organization will be at your disposal.

## A GOOD AD

THE other day a dashing new, maroon-colored, sporting body roadster sped past, about 25 miles an hour. It was a classy-looking 'bus, and naturally we turned to look at it after it passed, mentally wondering:

"What 'bus is that, anyway?"

But there was no need to worry. In letters six inches high, on the cover of the spare tire carried behind, stood out the name of the car, like:

BING BOY.

If you sell a model that's a little out of the ordinary, put the name conspicuously on the car, particularly in the rear. You know that impulse to turn and look after a snappy model when it passes? Well, capitalize that impulse!

## PRICES GOING UP, UP!

DO YOU notice how auto prices, and also the prices on some implements, are jumping? We don't like to say: "We told you so," but this is what we were arguing editorially last spring and summer. And the limit is not yet.



# ROSENHEIM BUYS PROTECTION

Pinched (With Permission) From "Timken Magazine." Sketches by CLYDE E. DARR.

"MAX," said Meyer Feldman to Max Rosenheim, proprietor of the Scotch Woolen Mills, High-Grade Men's and Boy's Clothing, as they sat talking in the latter's office, "such a carelessness you do, and it's goin' to cost you money some time. Why don't you buy it one of them ottermobel lockers? You leave your car standin' around in the street like it was a wheelbarrer already, and the first thing you know along comes a thiefver."

"Meyer, you gotter admit I'm a good bizness man, and why should I get me one of them expensive lockers



"Alright, maybe it's a mistake I make, but I take it anyway"

which if a thiefver steals the car, he steals the locker, too. No, sir; I got me a better way. Herman Epstein he writes me out one of them all-around policies what covers stealin', fire and damages by collusions or skidders. I let Herman do the worryin', yes—"

"Max," shouted Meyer excitedly, "what am I tellin' you? There goes a Holler for the police,

feller now, drivin' off your car. get it to the telephone."

Rosenheim's automobile, which a moment before stood at the curb, was now rapidly disappearing up the street, a bold robbery in broad daylight, but Rosenheim smoked on contentedly and made no move to have the thief taken.

"Already I pay Herman three premiums, and now I guess I get me a new car. There's Herman now. I think I tell him." Opening the window, he called: "Hey, Herman, I got news for you; come up here right away now."

When the insurance man entered, Rosenheim handed him a cigar from a drawer marked "High-Grade A, Number One Customers," and said: "Well, Herman, you're stuck. Just now while I was talkin' to Meyer here, one of them ottermobel thieves jumps in my car and drives it away. Make me a check right off, because I want to drive the new car home."

"Not so fast, Max," said Herman, calmly. "Was you car provided with a lock?"

"It was not. For why should I get me one of them expensive lockers when it was insured?"

"Did you notify the police immediately?"

"Of course not. They might have caught him, then my insurance premiums would have been a dead loss. No, I think I like better a new car. I get one with them wire wheels this time, I guess."

"Not at my company's expense. Listen to section four of your policy. 'It is understood and agreed that the party of the first part shall, within twenty-four hours after the issuance of this policy, provide said automobile with a lock of approved design, if the machine is not already so equipped, otherwise this contract shall be held null and void.'

"Also section eight," continued Mr. Epstein: "In case the said automobile is stolen, it is understood and agreed that the party of the first part shall immediately notify the police authorities, and at once endeavor to accomplish a recovery prior to notifying the party of the second part. Any failure or negligence of this provision automatically cancels the contract and, by agreement, prevents the institution of an action in court to recover any claim for loss.' So, Max, I would advise you to call up the police department. Your policy is null and void on two counts."

"So, you low-lifer," said the angry Max, "I pay you my money and now you and this feller Nulland Void, who I don't know at all, cheat me. And I thought you was honest."

Rushing to the telephone, he called the police department. "Hey, you bum policers, this is Max Rosenheim. My car was stole just now. What's that? You have the car? My, my, that's fine. Such a grand policer department what we have. What? All smashed up? Run into a telumgraph pole? All right. I come down in a hurry."

Hanging up the receiver, he turned to Epstein and said, "So smart you are, you and your friend Nulland Void. How you like this? That feller runs into a pole and makes it a wreck. Now you pay the damages. Ah, ha! He who laughs last tickles himself most, yes."

But Herman refused to be disturbed. "Section twelve of your policy reads: 'It is understood and agreed that the party of the second part shall not be held liable for damages should said automobile be impaired or injured when being driven by an unauthorized party. This policy covers only damages sustained while the machine is being operated by the party of the first part, or his authorized and accredited agent.' Max, in legal matters it is always well to read every line, and abide by your signed agreement." And Herman walked out exuding clouds of expensive smoke.

The car was not completely wrecked—a broken radiator, one wheel demolished and the front axle bent. Rosenheim had it towed to a garage for repair.

"It's pretty bad, Mr. Rosenheim," said the repair man, "but it might have been worse. It's a lucky thing you have a good front axle to take the shock, otherwise the whole car would have been junk. The axle beam can be straightened and it will be as good as new."

Rosenheim gloomily took the interurban trolley to his country home, where he told the sad news.

"Max," said Rachel, his wife, "so foolish you was not to get one of them lockers. I saw an advertisement of one, and now I'm going to write the firm."

When the Invincible Automobile Lock Company received Mrs. Rosenheim's letter it was given to the salesman covering that territory, and a few days later he was passing through. Although the letter was from his wife, he concluded to see Mr. Rosenheim at the store and make the sale there.

Rosenheim, still angry over a fifty-dollar garage bill, was in a bad humor, but he knew he needed the lock. The price, however, made him hesitate.

"Twenty dollars you ask me for such a little thing? Man, I can buy a lock for my house for a dollar and a halluf. Never will I pay me such a price. Fifteen dollars and a halluf at the outside; take it or leave it."

In vain the salesman talked, argued and pleaded. It was no use. It was the reduced price or no sale, and at last the man capitulated, angry at the deep cut in his commission. After handing over the lock the salesman angrily stalked out, leaving Rosenheim in a much better humor.

The lock salesman suddenly remembered that the inquiry had come from Mrs. Rosenheim, and feeling rather bitter toward the haggling clothing dealer he decided to make a hurry call at Rosenheim's home—perhaps he

might make a sale at full price. Catching a car, he rapidly made the trip and found the lady at home.

"Now, Mrs. Rosenheim, I have made this trip in direct response to your letter, and I think my house is entitled to the sale, since you admit that our advertising impressed you and that the lock is assuredly a perfect mechanism."

"All right; maybe it is a mistake I make in not consulting with Max, but if I telephone him, right away he thinks up them objeckshuns, so I take it."

"Thank you very much, Mrs. Rosenheim," said the salesman as he pocketed the twenty, "and now I must be going. I want to take the four-ten train, and I can just about make it by catching this car that is coming."

Soon after the departure of the salesman Max arrived in his repaired car, having decided to come home early. When Rachel informed him that she had bought an Invincible lock he exploded in wrath.

"And now I got me two of them. Oi, oi! had I my hands on that scoundrel, kill him I would. I get that feller. He takes that four-ten train, hey?"

Going to the telephone, he called up Isaac Meyerbaum.

"Say, Ikey, look out by the depot platform, and if you see a feller in a gray suit, with a brown hat and a speckled tie, carryin' a grip, hold him for me till I come," then he hurried to his car.

On the platform awaiting the arrival of his train stood the enterprising salesman. Mr. Meyerbaum approached and said, "Max Rosenheim, he just telephoned me to say he wanted to see you. He's coming from his home now in his ottermobel. He seemed excited."

"Rosenheim, Rosenheim. Let me see. Oh, yes, you mean the proprietor of the Scotch Woolen Mills.

Well, well, that's fortunate. The matter slipped my mind entirely. You see, here is a letter from Mrs. Rosenheim, wanting to buy one of our Invincible locks. Now isn't it too bad that I can't wait? I must catch this

train that is coming now. Say, Mr.—ah, Meyerbaum, isn't it? Mr. Meyerbaum, you can do your friend an immense favor. Here is one of the locks, twenty dollars. You take it and Mr. Rosenheim will be eternally grateful."

"Oh, well, I don't mind doing Max a favor. Here the twenty is, and here comes Max, waving one hand like he was crazy."

The salesman boarded the train and was whirled away just as Rosenheim's car halted at the platform.

"Ikey, Ikey, for why didn't you hold him?"

"S all right, Max; I got it for you."

"You got it, you got it! You idioter, what you mean, you got it? What! Anodder von? Oi, oi! Oi, oi!"

"Max," said Meyerbaum, after explanations had been made, "telegraf to the policers and they will hold him for you."

"Nu," said Rosenheim, wearily, "he would sell them mebbe a gross of the dam things for me. Never do I want to see him again, unless it is to hire him as head salesman. I know when enough it is I get."

## SASK. IMPLEMENT DEALERS ORGANIZING FOR EFFICIENCY

A NUMBER of implement dealers of the Province of Saskatchewan, members of the Retail Merchants' Association, met as a Trade Section of the Association, in Regina, Jan. 6, for the purpose of discussing various matters of interest affecting the retail implement trade as it stands at the present time. In May last a joint meeting of retail and wholesale implement dealers of the province was held in Regina, when various resolutions were adopted with regard to the retail implement trade, which the wholesalers promised should be submitted to the various offices as recommendations with a view to some action being taken. The present meeting considered it somewhat unfortunate that no steps had apparently been taken in this direction, which consequently meant that the matter stood as at the time of the previous meeting.

In order to overcome this condition of things and to ensure a greater measure of success and in view of the increased amount of clerical work to be done at the provincial office since the amalgamation of the implement dealers with the Retail Merchants' Association, it has been found necessary to employ a man who thoroughly understands the implement business to devote his entire time to the implement section. It is also necessary to compile the necessary details in order to show the position in which the retailer in the implement business is placed to-day, and to bring about greater co-operation, not only in the Province of Saskatchewan but throughout the West.

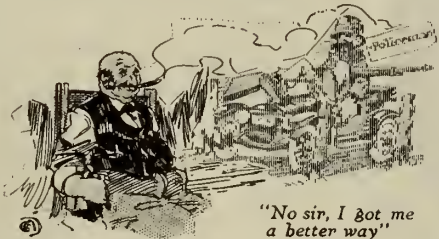

"No sir, I got me a better way"



"Max," shouted Meyer, "there goes a feller now drivin' off your car"



"You got it; you idioter, what you mean you got it"



# Three Storiottes of Implement Dealers' Successes

## A Satisfied Customer Will Send You Prospects

**B**UY EVERYTHING for cash and take whatever discount is going.

This is the practice which has helped Leonard Farr, implement dealer, of Woodbridge, Ont., along the road to success. Mr. Farr has been selling implements in Woodbridge for five years, and during that time, by intelligent handling of the financial end of his business, has managed to work up a sound connection. Discussing with the M.-T.-I. some of the chief points which helped to build up his business he says:

"The first thing an implement dealer should do is to educate himself; he should study carefully everything he handles and earn a reputation for knowing his goods. Such a reputation will give the dealer a prestige that will do great service for him among his customers. He should never forget that the farmers talk, and if he can get them talking about him his battle is half-won.

"I buy everything for cash.

"It didn't take me long to see that it would be to my advantage to drop the consignment policy and operate on a cash basis. On the present margins offered by the manufacturers—which, by the way, I think are too small when one considers the service a dealer is expected to give—the discount allowed for cash helps out considerably. I also advise my customers to buy for cash, and about 80 per cent. of them do so.

"I believe in service, and in giving the best quality of service of which I am capable, I try to make my customers feel when they deal with me that they will be well looked after. It is a good thing to have customers say:

"If you buy from So-and-So you are quite safe; he can fix it."

"I endeavor at all times to give prompt service and handle all the repairs myself.

"Most of my prospects are obtained through satisfied customers. I don't suppose I have gone out one day in a year without having had a prospect or a definite objective.

"I find many of the farmers who come in to my place are interested in machinery and love to talk about it—even when they have no intention of buying. When I find a man like that I discuss my goods with him and supply him with lots of literature, and it is surprising how interested he becomes. He talks about my machinery among his neighbors and is delighted when he can help me make a sale.

"There is just one thing more I would like to mention, and that is trading in second-hand goods. It is a bad business, and one for which I have no sympathy. As I said before, the margins are small enough without reducing them any further by handling whatever 'junk' a farmer pleases to trade on a new article.

"There is one case, however, where I make an exception, and that is when a farmer has an engine—in good repair—which has become inadequate for his purposes. When I sell him a larger engine I allow a discount on the original one, because someone is sure to want just such an engine."



LEONARD FARR.  
Woodbridge, Ont.

## Case Winner Gives Some Rules For Success

"**A**N IMPLEMENT dealer nowadays has to be a truthful man if he would succeed in his business," said Delos Ressor, implement dealer of Agincourt, Ont., when discussing with M.-T.-I. some of the points which led to his becoming the banner salesman in 1919 for the Case tractor people in the Toronto district.

"Whatever success I have had," says Mr. Ressor, "has been achieved by hard work, honest dealing, a belief in the goods I handle, and last, but most important, service.

"I don't make a promise unless I know for a certainty I can keep it. Every promise I make I fulfill to the letter. An agent who treats his promises lightly will one day find himself without a job. No farmer will do business with such a man.

"Next to honest dealing I place service; in fact, they are often one and the same thing. In order to give proper service, a dealer should be more or less of a mechanic.

"Before entering the implement field I was a railway mechanic. I served an apprenticeship of five years and worked as a full-fledged mechanic for many years. I attribute a great deal of whatever success I have achieved in selling implements—tractors especially—to my knowledge of mechanics.

"There is nothing about the machines I sell I cannot repair. I make a point of completing a repair in one day—even where there is a serious breakage. In the event of a serious breakage, if I have no spare part on hand to replace the broken member, I jump on my car, go to Toronto, secure the required piece, return to the job and make a satisfactory repair, all in one day. So far I have always succeeded in doing this.

"A customer to whom I had sold a tractor one day went out to do some plowing for a neighbor near whose farm a sale was going on. He wanted to do a neighborly turn and also show off his machine to advantage.

"He arrived on the scene bravely enough, but when he commenced to plow the tractor balked and positively refused to work.

"He immediately 'phoned me, but I was away at the time. He was very much upset about his little exhibition falling through. He got a neighbor to drive him to Toronto, but on reaching the Fairbanks-Morse factory he was told all the service men were out. He was very angry and said some nasty things to the people at the factory. They advised him to go back and try again to get in touch with me, which he did, this time succeeding.

"When I went out and looked the tractor over I found the whole trouble was simply a dirty spark plug, which I fixed in ten minutes. The farmer was delighted, offered to pay me and asked me to send his apologies to the Fairbanks people for things he had said. I find a satisfied customer is the best advertisement.

"Last year I succeeded in selling four-teen tractors, 90 per cent. of which were sold for cash. I didn't start in until June, and I believe if I had had adequate help I could have sold twice as many."

## He 'Cops' Five Century Notes

"**S**TEVE" Mc Cann is the live community. surrounding Eganville means the best tario, yet Mr. McCann is a dealer trade that in the best The business was father 40 years

"My trade," said limited by the na land surrounding ample, the rocky the sale of trac "It has been our customers a service them permanent matter what diff has with machin purchased it we try to solve it tance is too far for cases. It is this service that gains the confidence of farmers. They don't forget when buying new equipment. I can recall numerous cases where farmers have come to our warerooms for equipment when I was out on my territory. They knew from experience they would get the best price and all the service that went with it.

"The success of the dealer to-day depends on the honest service he is rendering his community as a citizen and a merchant. If he connects up with the manufacturers who are leaders in their respective lines and then keeps goods on hand commensurate with the needs of the community, he has laid the foundation for a profitable trade

"I try to take full advantage of the co-operation given by the manufacturers. When their travellers come into my territory I take them right out among my prospects so as I can get from their selling new ideas and arguments which will help me later. I have driven 35 or 40 miles a day with them, called on customers even as late as eight or nine o'clock at night—and signed up orders, too, at that hour.

"**I**N selling farm equipment I try to be more than a mere connecting link between the factory and the farmer. I aim to impress on the farmer what the installation of our equipment will do to lighten farm work and make life more pleasant.

"I have noted with a great deal of satisfaction the tendency on the part of farmers to pay cash. I would say about 50% of my sales are cash sales."

Mr. McCann won the \$500 prize awarded by the Renfrew Machinery Co. to the dealer signing up most business during 1919.



J. S. McCann, Eganville, Ontario, winner of the \$500 prize awarded by the Renfrew Machinery Company to the dealer sending in the greatest volume of business during 1919.

CANN is known wire dealer in his While the territory ville is not by any farm land in On-Cann has develop-which will rival sections of Canada. established by his ago.

Mr. McCann, "is ture of the farm Eganville. For ex-land limits greatly tors."

aim to give our which will make customers. No culty the farmer ery, whether he through us or not, for him. No dis- us to drive in such

They don't forget when buying new equipment. I can recall numerous cases where farmers have come to our warerooms for equipment when I was out on my territory. They knew from experience they would get the best price and all the service that went with it.

The success of the dealer to-day depends on the honest service he is rendering his community as a citizen and a merchant. If he connects up with the manufacturers who are leaders in their respective lines and then keeps goods on hand commensurate with the needs of the community, he has laid the foundation for a profitable trade

I try to take full advantage of the co-operation given by the manufacturers. When their travellers come into my territory I take them right out among my prospects so as I can get from their selling new ideas and arguments which will help me later. I have driven 35 or 40 miles a day with them, called on customers even as late as eight or nine o'clock at night—and signed up orders, too, at that hour.

In selling farm equipment I try to be more than a mere connecting link between the factory and the farmer. I aim to impress on the farmer what the installation of our equipment will do to lighten farm work and make life more pleasant.

I have noted with a great deal of satisfaction the tendency on the part of farmers to pay cash. I would say about 50% of my sales are cash sales."

Mr. McCann won the \$500 prize awarded by the Renfrew Machinery Co. to the dealer signing up most business during 1919.





# Are YOU, Mr. Dealer, Really Dozing?

*M.T.I. Correspondent Suggests That Caravan of Motor Trucks Should Turn West*

**Y**OU CAN count me in on it with a couple of trucks if the rest come in."

The speaker was H. E. Walker, Western manager of the Grace Motor Company, the largest dealers in motor trucks in the Prairie Provinces, and his statement was made at the close of a long and interesting conversation in which we discussed the suggestion that a caravan of motor trucks of all makes should make a tour of the Prairie Provinces this Spring in order, by this spectacular advertising method to arouse enthusiasm and awaken interest in the motor truck as a factor in solving transportation problems.

Mr. Walker made an astounding statement:

"Western Canada," he said, "is one of the greatest potential fields in the world for motor trucks. I have learned at a cost of many hundreds of dollars during recent months that the consumers are right now ready and willing to buy, but it is simply impossible to awaken the interest of the dealers."

"The farmers cannot buy until the trucks are offered to them for sale, and the fact of the matter is that the dealers will not apparently be forced into introducing the truck until the demand becomes so overwhelmingly great that they cannot avoid taking action. As near as I can figure, it will be two or three years before this can happen if something is not done to awaken the West and set it talking motor trucks."

"I am intensely interested in M. T. I.'s suggestion," said Mr. Walker, "and I will go so far as to say that I will come in on it if you can induce the other motor truck dealers to do the same. While I am naturally of an optimistic nature, I must say that I have little hope of arousing the Western dealers by any method. Just this morning I talked for an hour and a half to one of my travellers who has been to many points in the West, and I may tell you that what he said was very discouraging. Like everyone else who has travelled the West, he found the buying public was greatly

**By E. H. SCOTT**

## IS THIS TRUE?

**"Whole West is ready to buy trucks, but dealers are lifeless. It is impossible to wake them up," says H. E. Walker, of Grace Motors.**

interested in motor trucks; in fact, the whole West seems ready to buy trucks, but the dealers are lifeless on the subject. It is impossible to wake them up.

"Now, the expenses of this traveller ran into a very considerable figure, and it looks as if it will be a very long time before we get back the money expended in an effort to educate the dealers. The only bright spot in this dark outlook was the sale of a five-ton truck in Moose Jaw.

"Take a look at that map on the wall with points in the Prairie Provinces marked with colored stick-pins. It cost us many hundreds of dollars to learn where to place those pins, and every one of them represents a possible sale. We not only hear from our own travellers, but from many others returning from the West, that the field is ripe and more than ripe for trucks. The problem is to connect up the demand with a source of supply."

**"BUT,"** I INTERJECTED, "surely it would be better for the motor truck manufacturers to combine in one great effort to arouse the dealers rather than sit calmly back and wait for events to take their course!"

I discoursed at length on the advertising possibilities of a truck parade around the West.

"Listen," said Mr. Walker; "I have been through every phase of the truck-selling game, and while I am optimistic, and while I am willing to try this stunt and lend all my endeavors to make it a success, I

think it will take something more in the nature of dynamite to move the dealers. Suppose, for instance, that a representative of this firm were to go right out onto the farm and sell a truck to the farmer through the local dealer. What would the dealer do? He would demand 20 per cent. commission. He would order that one truck, and the matter would end there. The thing has been tried again and again."

Mr. Walker went on to state that there were other phases of the problem. For instance, he had found from his investigations that in Southern Alberta the larger trucks were in demand, while in Central Saskatchewan much smaller trucks were wanted. He concluded with the statement that it might cost as much as \$3,500 to send out a couple of trucks on the proposed trip, to say nothing of the depreciation in value, but he was willing to charge this up to advertising and take a chance if all the truck dealers would come in.

Personally I can vouch from my own experience for the statement by Mr. Walker that the Western demand is there. If there was one thing more than another that impressed me in the course of my perambulations around the West in recent months, it was the fact that the prairie country is ripe for the introduction of the motor truck. In various issues of M. T. I. I have given the views of dozens of Western implement men on the subject. Most all of them with whom I talked were agreed that the enquiries of the farmers had reached a point where it was time to get action. The sale of automobiles by tens of thousands has thoroughly converted them to the use of gas-driven vehicles over those drawn by horses. They have figured it out that, in especially the case of long hauls of wheat to the elevators, the superior carrying capacity of the motor truck, coupled with the speed at which round trips can be made, would result in a marked economy over the tedious methods now in vogue of taking a day or a day and a half for a round trip of say fifty miles with horses.



Quite unexpectedly I was apprised of the interest of the farmers themselves on this subject during a visit at harvest time to a settlement 25 miles from Empress, Alberta. As usual at this season of the year, the farmers were co-operating with each other in the work of threshing the grain on each other's land, and I happened to catch a goodly number of them at the home of the friend I was visiting. In a kitchen so blue with tobacco smoke as almost to obscure the big nicked range, the talk swung from one thing to another until the question of hauling grain to town became the subject of conversation.

IT WAS then that I realized the deep interest that these Westerners are taking in the development of the motor truck. That they had been thinking pretty deeply on the matter was apparent from the spontaneity with which they voiced their opinions on the cost of operation. Figures were quoted freely on the cost of motor trucks laid down in their home town, and such questions as the consumption of gas, the use of trailers, the cost of upkeep, the number of trips that could be made in a day followed in rapid succession. There was never a word said about road conditions that would mar the working of the scheme. Some of the farmers favored the smaller types of one-ton trucks, but the majority had it figured out that the larger types, capable of hauling trailers, would be the most economical. The figures they quoted with regard to the cost of hauling wheat with four-horse teams made the motor truck a very attractive and alluring proposition indeed.

The question of purchasing a big motor truck on shares seemed to meet with approval, and it was made very clear in the course of the debate that such a truck could be kept pretty busy throughout the Spring, Summer and Fall hauling in food supplies, lumber, coal, etc., when not in use hauling grain to market.

With these farmers located twenty-five miles from a town the question of transportation was a vital thing, and the problem that confronts them confronts many thousands of farmers in all parts of the West similarly located. Accustomed as they are to running into town in an hour with their motor cars, they do not take readily to getting up before dawn in a chill October morn, to feeding four horses, hitching them up, and starting off on a five-hour trip to town perched on a load of sixty bushels of wheat.

It is really a surprising thing, as I told Mr. Walker, that in view of all the talk on the subject the great and wealthy West is comparatively barren of motor trucks. The only reason I could ascribe to this condition, I told him, was that the manufacturers have not taken the proper means to introduce and develop this business in the West. I urged upon him that *the manufacturers and the trade in general must get together and do something spectacular in order to get the movement of trucks under way.*

I told him that I had thought over the problem a great deal in recent months, and that the answer came to me the other day when I purchased a copy of the *Los Angeles Times*. Coming to the automobile section of the big Sunday issue the first thing that hit my eye was an illustration the full depth of the page showing a long line of motor trucks, each of them decorated with cotton signs and flags, and extending in an unbroken line almost to the horizon it seemed. I read the story with the keenest interest. It went on to tell how the manufacturers of many of the best known trucks in America had combined to put on this most striking demonstration of the practical utility of the motor truck for hauling freight between the various towns of Southern California.

MAKING THE city of Los Angeles a starting point, the long line of trucks, loaded to capacity, started out on an itinerary that was to take them on schedule time to most of the important towns in a wide area north and west of the City of the Angels. Later, so the story ran, they were to make a trip through the south even more ambitious in scope.

The whole thing was an advertising stunt pure and simple and conducted along colossal lines, and while it was not exactly free advertising, I doubt if these manufacturers could have achieved the same results by spending hundreds of thousands of dollars through the legitimate advertising channels. As a matter of fact they did use the advertising columns of the newspapers freely, but the manner in which the various papers competed with one another to give space in their news columns to the exploit overshadowed everything that was done in the form of display advertising.

The most exhaustive detailed figures were given of the power and capacity of each truck, together with the load it carried, and as the demonstration proceeded details were given of the amount of gas consumed, and the actual cost of delivering freight by this method. The plans must have been made weeks in advance for there was not a thing overlooked that would tend to attract the interest of business men along the route. Receptions were planned at every centre. The newspapers in each town heralded the arrival of the advancing train and kept their readers advised of its progress. As the journey proceeded it was arranged that the trucks would pick up freight for the return trip to Los Angeles. The whole thing went swimmingly. It was a tremendous success in every way.

But perhaps the most remarkable feature of this brilliant idea was that the manufacturers saw the need of an educative campaign of this kind in a district where everybody is supposed to be as familiar with the motor vehicle as a baby is with its toes. One would think that in a district so densely populated as Southern California, where motor cars are legion, that there would be no need of such a campaign. In the same issue of the *Times* that this story appeared there was more than a page of condensed advertisements of motor cars for sale.

MR. WALKER told me I had made my point clear: That if California needed such a demonstration, how much more urgent was it that spectacular means

should be taken to waken Western Canada to what it is missing.

What I proposed to him was a parade next May through Saskatchewan and Alberta of all the motor trucks that can be gathered into line. I would have them swing around the loop up through Saskatoon to Edmonton; down to Calgary and Lethbridge, and back through the south country to Regina. If it were feasible Manitoba points might be included in the journey, but there is not the same need for trucks in the older Province, with its network of railways, that there is farther west. I think that the trip would prove a revelation to the West, and that it would accomplish in a few weeks what might otherwise take years to bring about by the slow method of waiting for the idea to take root.

Every detail of the California plans could be carried out in Western Canada, and not only would it prove to the farmers that trucks can be used on the western roads, but it would bring the merchants of the various towns to see the value of the motor truck in their various lines of business.

A stunt of this kind could only be pulled off by manufacturers broad-minded enough, and unselfish enough, to forget competition in order to pave the way for a great volume of business for all concerned. Results should be achieved immediately, for agents could be appointed in every town, and the ball set rolling toward a truck output that would bring handsome returns. The West is wide open and ready for a campaign of this kind. Will the manufacturers come in?

## From Oxen To Tractors

FROM oxen—to horses—to tractors, have been the usual steps in the farming evolution of most countries, but Turkish farmers are going this one better and changing from the plodding, swaying oxen direct to the modern tractor.

They have been quick to see the great advantage in using a tractor, over their old custom approximating six oxen to one plow. By this modern method, they say, they can accomplish their own salvation through the cultivation of their large areas of fertile soil that have lain idle for many years.

Every demonstration draws a crowd of keenly interested farmers who watch closely and comment freely. At one demonstration near Constantinople, where the G-O Tractor plowed 8-inch furrows in a large tract of land that had not been plowed for over

a hundred years, one wearer of the Fez said that it would take 20 oxen to pull the same load.

### TO-DAY'S BOUQUET

Editor, M. T. I.—Allow us to express once more our great appreciation of the *MOTOR, TRACTOR AND IMPLEMENT JOURNAL*; it has filled the want in the most satisfactory way. It has certainly made a hit with the dealers and we are frank to admit that it is the most up-to-date journal in Canada to-day.

Yours very truly,

Western Motors, Ltd.

G. W. Nearing.



Above—Groups of interested Turkish farmers follow the tractor up and down the furrows at every demonstration. Note the attention the tractor gets even from horses.  
Below—Closer view of a Turkish one-plow equipment. Three such as this are being replaced by one good tractor.



# The PERSONAL ANGLE of SERVICE

Who Said "Free" Service? There's No Such Animal!

By H. E. BRASIER



H. E. BRASIER.

NEW thoughts on any subject are generally found to be old thoughts in new dress, so that I cannot attempt to be original for in reality I am dealing with a very, very old subject.

Service is an important proposition in any organization,

but especially so to us engaged in the automotive industry, for there are very few of us who do not look back to the time when service was the bugbear that haunted us and to which we attributed most of our hardships.

Service means the performance of any good, and when we apply it to the automobile business a clear definition may be set forth in this way: To do what is necessary promptly, courteously and efficiently at a proper remuneration.

It is the duty of the automobile service man to stand between the owner of the car and the producer in such a way as to preserve that integrity which should always exist between buyer and seller, and whereas it is the function of the Sales Department to sell cars, we may consider it the function of the Service Department to keep those cars sold.

When a man buys an automobile we must think of him as making a greater cash investment than he does on perhaps any other occasion, except of course, when he may buy property or some wonderful art treasure, but he buys the car for a distinct purpose—he expects to get both pleasure and profit from its use, and further, he expects to get pleasure and profit from its continual use. It is, therefore, the duty of any Service Department to protect the owner against tie-ups which necessarily mean a great deal to him in a way both directly and indirectly expensive.

The factors that count for the most in Service are available in unlimited quantity and without cost, and I refer to three essential things:

## COURTESY, CARE and CLEANLINESS

The average automobile owner when in trouble is generally in a rather irritable frame of mind—all of his plans upset and for the moment at sea. The first impression that courtesy makes upon him is to minimize his difficulty, to make him feel that he is in a friendly court and that everything possible will be done for him.

CARE comes on the scene when we listen to his report, when we make our diagnosis and when we carry out the necessary operations towards getting his car back on the road. Everyone touching his car must be careful, and it is astonishing the results that will follow a crusade for greater care in handling repairs for owners and in safeguarding their cars while in your possession.

For an owner to come into a clean garage will immediately register in his mind an impression of reliability, and will send him out of your establishment with a feeling of confidence in you and in your methods. By cleanliness I can hardly mean that dirt will be entirely eradicated, but especially in this day of closed jobs there should be a clean smock very handy so that when the necessity of handling a closed job arises, you are able to protect expensive upholstery by merely insisting that your mechanic put on a clean smock before going at the car. Dirty steering wheels and soiled cushions have caused more cussing and lost as much business as any other mean element in our work.

Develop these three factors of Courtesy, Care and Cleanliness, and in order to do this it is necessary to more closely study the members of one's staff—get under their belts and bind them to your institution so that their loyalty is yours. I can hardly give you a formula for doing this because men are different, but you get my thought when I tell you that the man who merely comes to your establishment in the morning, stays there all day and goes home at night, even

though busy all day, may not be getting the results that you require. Every tap of work done must have a definite purpose.

It is a good thing to go over your wage scale once in a while. 2½c more an hour voluntarily extended by you at the right time will bring you greater returns than the extension of five or ten cents following agitation and discussion, and will command the personal interest of your worker.

Supposing you put a new car at the disposal of your garage foreman and tell him that you want him to go on a test run; that he would likely be gone a couple of months and that he was to see that his car was in good shape for starting at a certain time. It would be human interest for that man to take a greater interest in the preparation of that car for its journey than he would take if you gave him the same instructions and told him you were going to drive the car. It is our natural inclination to be scrupulously careful where our own comfort and convenience is concerned, and if we can step into the other fellow's shoes once in a while and get things from his angle, we are going to get results.

WE have heard a great deal about the duty of Service to Sales, and, on the other hand, Sales owes a considerable duty to Service, and I may say with all respect that weak selling methods have been responsible for a great deal of the vagueness that has

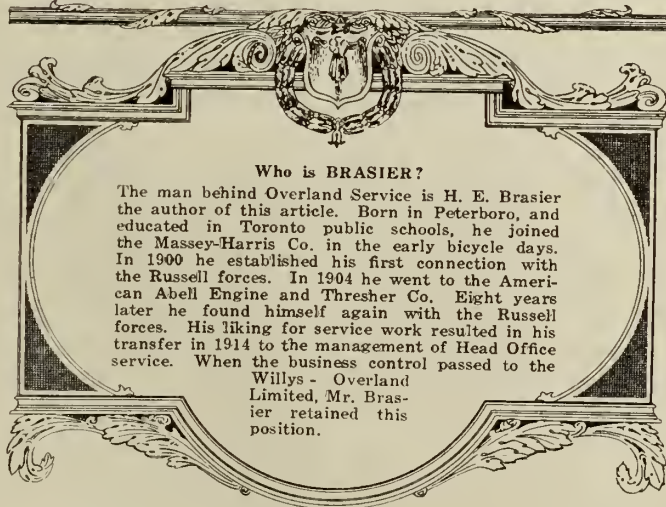

### Who is BRASIER?

The man behind Overland Service is H. E. Brasier the author of this article. Born in Peterboro, and educated in Toronto public schools, he joined the Massey-Harris Co. in the early bicycle days. In 1900 he established his first connection with the Russell forces. In 1904 he went to the American Abell Engine and Thresher Co. Eight years later he found himself again with the Russell forces. His liking for service work resulted in his transfer in 1914 to the management of Head Office service. When the business control passed to the Willys - Overland Limited, Mr. Brasier retained this position.

become associated with Service in the owner's mind when he buys his car.

I think a more straightforward setting forth of what is to be expected will win the owner's respect, and he will feel a great deal happier if he knows how far he can go and where he stands in the case of attention being necessary. The Warranty should be very carefully explained and, most important of all, the owner of a car should not be turned loose with his new vehicle until more than ordinary care has been taken to educate him in its care and operation. Evening classes to which owners have been invited have been very popular.

Sometime ago the Sales organization throughout the country got the idea that they would be better off if they got their Service on a back street, away from the Sales room, but I want to tell you that if the Service is handled right the very best place for it is in the same building. The trouble has been that the owner has been put into a new car and away he goes without becoming acquainted with the Service Department and without any idea whatever as to how to get results when necessary. I believe the average man will appreciate it very much if told when buying his car just how your Service Organization operates. Introduce him to your Service Manager, and let them chat things over. Good results will follow.

Just a word or two on another angle: How can the dealer help the factory? Primarily, by full accumulation of facts on any incident requiring discussion. When writing to your headquarters give

them full information as to the model and serial number of the car, when purchased, number of miles it has been driven—every possible piece of information that will assist the Service Department at headquarters in studying your particular proposition and in getting results for you.

This feature of care is also especially necessary in placing parts orders. Make sure that your stockman has proper publications at his disposal from which he can secure the exact identity of any parts that are required.

YOUR repair department should be very closely in touch with your parts stockroom, and it should be an unheard of thing for a repair to be commenced without ascertaining whether the parts required are available or not. Fancy what happens if you tear a car down and then find yourself stuck for some little part. You not only lead the owner of the car into a condition of worry, but you also disorganize your repair shop, and when you finally secure the part required, you find somebody has misplaced this or that part prematurely removed from the car.

If we could only catch the fellow who first associated the word "Free" with Service, or, in fact, if we had caught him young enough, we would have saved ourselves a lot of unpleasantness. I do not think there should be any such thing as "free" service—in fact there is not—somebody has to pay for it.

Another bugbear in the Service end is the use of coupons. Why give a man \$40.00 worth of coupons entitling him to free service when there is reasonable indication that his car may run along smoothly and he will not require that service? You cannot control the amount of service you extend in this way for upon the forty hours' service being exhausted something might happen in which you should take a hand and it would be your duty to ignore the coupon idea entirely and consider the situation on its merits. I think we should extend service where service is due. Be very careful about accumulating all facts, and then it will not be hard for you to decide upon your happiest solution by simply doing the fair thing.

We have all noticed that good service can come from the small establishment with mediocre equipment as well as from the splendid establishment equipped with every up-to-date facility, so that there must be some element involved in service that is more than a material one, and after watching this work for a good many years I am convinced that the amount of personal interest that is injected into your Service organization by yourself and by those under you will measure very accurately the degree of success that is attending your operations.

The laws of business are at work whether we realize it or not, and you can take a very valuable lesson from the present exchange situation, i.e., export more personal energy into your business than you take from it and in that way protect your personal business valuation.

## PRODUCTION IN 1930!

A WRITER, with a rather facetious turn of mind, has a story in a recent number of *Engineering*, in which he describes a motor car being turned out in batches of 10,000 at £50 each. The story is dated 1930, and released for publication now, no doubt, in order that people may hold their automobile orders for the new car.

The manner in which automobile production has been brought to a science, and turning out of parts speeded up to a tremendous rate, also has the tendency to open the door to the writer who sees in this age of specialization the opportunity to lead in the absurd and the ridiculous.

So when the mechanical specialists of the automobile world find writers having their little fling at them and at their work, they will simply have to grin and bear it. Such is fame.



THIS probably will be the last article for some months in M. T. I. by Mr. Glover, whose contributions since last August — bristling with ideas for the small-town garage man—have been such a popular feature of this publication.

Mr. Glover, who went to Goderich, Ontario, nine years ago with nothing but a kit of tools, several years' practical experience in repairing autos, and a few dollars—plus ideas—has disposed of his East Street Garage for 'ump-teen thousand dollars. We hate to say exactly how many—it makes a mere editor envious!

The purchaser is T. F. Holland, who takes charge March 1, with a wonderful asset of good will in the community, left with the business by Mr. Glover. The latter, we are pleased to say, is taking his first holiday in nine years, and going to motor to California.

# What Does the Credit Man Think of You?

By ARTHUR M. GLOVER

financial end is concerned. If the business is operated at 75 per cent. of its efficiency it can be made a paying proposition, and if at 100 per cent, why it will make money in "chunks" for the owner.

IN THE first place we have to get the fact that the terms on which goods are bought are serious obligations, and if goods are bought on terms calling for payment in thirty days, they have to be paid, by hook or by crook, in *thirty days*; not *thirty-five* or *forty*, but *thirty days*. If you have any doubt at the time of buying of your ability to meet the account at the stated time, and this fact is mentioned to the traveller with the request for six-days, in nine cases out of ten the extra accommodation will be granted. It is the carelessness in regard to accepted obligations that makes the bad impression on the "credit man," not a little extra time for payment.

Then again it is the usual practice for wholesale houses to allow a discount if an account is paid "on or before" a certain date. This date is marked on the order and invoice, and is also plainly shown on the statement rendered. It is a common practice to allow the account to become overdue, and when a "dunner" is sent the garage man will send a check *with the discount deducted*.

Is this honest? I don't think it is. It amounts to this: You are using money which by all moral and legal rights belongs to another man or firm. They were good enough to allow you the use of their goods — which is only money in another form — for a period of say thirty or sixty days — whichever the case may be—free of all cost, but you now return this favor by taking it for a further term and not paying a cent for the obligation. In fact, you pay them less than you owe them, for you have deducted discount that you were only entitled to "if you had paid on the date due."

Would you go to any bank or private person and ask for a loan to operate your business for a period of thirty days or more and expect to get it free of cost? You would stand a pretty poor chance of getting it if you did. Because you happen to have your hands on money — or goods — of a firm, you take the extreme liberty of operating your business on their capital.

THIS question of credits is a vexed one, and at times a serious one, especially with the small man starting in on limited capital. I know from my own experience what it is to operate with insufficient money; but that is no excuse why one should use the other fellow's money in direct contradiction to the contract entered into to pay on a certain date. I have bought hundreds of dollars' worth of goods with no cash on hand at all. Before ever giving the order, I would put the matter plainly before the firm from whom I was purchasing and tell them I would require credit until it was possible to move at least a portion of the goods, undertaking to remit as fast as goods were sold. If firms are approached in this way, and if it is possible for them to modify their rules to meet the case, they will do it, for they are just as anxious to get all the business they can as you are.

It is a well-known fact that a man's own personality counts for more in most credit men's opinion than actual capital. A man whose integrity is unquestioned can go to any firm of standing and get a line of credit that will enable him to open up a business on very small capital. The known "crook," or one who makes every effort to avoid fulfilling his obligations, sometimes cannot buy goods even if he has the cash in his hand to pay for them. High-class business houses prefer to do without their business. After all it comes down to the old proverb, "Honesty is the best policy."

If we were in a business that was operating on a basis of 10 or 15 per cent. profit, there might be more to the argument for not meeting our obligations when due; but you know as well as I do that the average profit on our total turnover in a season is much higher than this, and it simply means that you have *got* to collect the amounts that are due you from your customers, so that you in turn can "pay up" at the right time. You can use the argument I have outlined above on your customer, for its logic is unshakable, no matter from what angle it is attacked.

It is no use writing to your supply houses and telling them you find it difficult to make collections; that's no affair of theirs, and they have troubles of their own in that respect. Get out and do what is necessary to put you in such a position that you can hold up your end of the game, for this credit is an endless chain affair.

YOUR customer has to pay you before you can settle; you have to settle before the jobber can settle; the jobber has to settle before the manufacturer can settle for material and wages; if your manufacturer doesn't get his wages he cannot pay you, and after all it is *your* fault that he didn't get his wages. Very few large firms are careless as regards their payments, and it is certainly up to the retailer to see that his link in the chain will carry its load along with the others. He can do it by a little careful study of conditions surrounding his business.

In the first place, get out your accounts and make a *serious effort to collect them*. Drop those that are notoriously *bad pay*—you will find yourself "dropped" by the jobber one of these days if you continue to be "bad pay." Then when you have done your very best — and please see that it is your very best — clean up your stock and get rid of some lines that are proving stickers, even if you have to sell them for half what you gave for them. The only way they will ever help you to get abreast of those accounts owing is by turning them into currency, and you had better get half what they cost than lose the whole thing; for that is just what you are going to do if they lie in stock much longer.

Then look around the workshop and cut out a lot of the waste that is continually going on there by stuff not being accounted for and tools lost. Watch the floor sweepings for a few days and see how many nuts, bolts, washers and cotter pins are to be found in the pile of dirt.

One might go on to almost unlimited lengths expounding this subject, but it shouldn't be necessary to go any further. Simply live up to the *Golden Rule*—"Do unto others as you would they should do unto you"—even if the "others" are the wholesale houses you are always fighting—and you will soon be sailing along in much smoother waters.

## AUTOMOTIVE IMPORTATIONS, 1919

MORE than 10,000 tractors were imported into Canada during 1919, according to figures furnished M.-T. I. by the Department of Trade and Commerce. The passenger cars imported totaled 9,367, and trucks 2,113. The pleasure cars were stated to cost \$9,304,235, and the trucks \$3,437,464.

The exact number of tractors admitted through the customs is 10,092, valued at \$10,647,557. It is interesting to note that only 317 were valued at more than \$1,400.

IN THE course of conversations with travellers from various houses and in answer to the question, "Tell me frankly what the credit manager really thinks of the average garage man as a credit risk?" I have received this answer, or one amounting to the same thing:

"Look out for the garage man, he is pretty sure to be either bad pay or at least slow in making settlements."

This attitude naturally re-acts to the detriment of our business, and is a state of affairs that ought not to exist. We are in the best paying business to be found in the world to-day, if only a portion of the business sense, used in the conduct of other lines of business, be displayed in the operation of the garage business.

This is our own paper, so we can stand plain talking, for it is not going into the hands of the consumer — besides it is better to be perfectly honest with ourselves and try to find out the reason why some of us are not making the money we should while engaged in a business so potent with opportunities.

In how many businesses will you find so many shipments sent C. O. D.? Not many, I warrant; and the only reason for C. O. D. charges is that our credit will not stand the pressure of a charge account.

Some firms will say that they send shipments C. O. D. to cut down bookkeeping; of course, we all know that they book C. O. D. shipments, and keep track of them until returns come in, and this is little less trouble than entering them up in the usual way. Does the grocer, sending for an odd case of cereals, or the shoe merchant for a special pair of shoes, get them C. O. D.? Not very often; and these items will often amount to less than what the garage man is told "is too small to keep accounts for."

It is not that our items are too small to keep account of, but that the maker sees in his mind's eye a whole string of small accounts that he may have to send three or four "dunners" to, and maybe threaten legal proceedings to collect. I can prove that it isn't the bookkeeping they object to by the very fact that they are all willing to open a "charge account" if you will place a deposit with them. If they didn't want the trouble of bookkeeping they certainly would object just as much to charging shipments against a deposit as against a regular account.

It would surprise the average small garage man to know what he pays out each year in C. O. D. charges. He would find that — if this amount could be eliminated — he would have enough extra profit to buy the clothes he needs for himself. Surely that is an item worth considering. The custom has become so firmly established with the different houses as to be impossible of removal in a short time; but it can be removed by putting our house in order as far as the



# SELLING THE FARMER ON BELT POWER



Many thousands of tractors in Canada are usefully and profitably employed filling silos.

SUPPOSE "madam" were in need of a new kitchen range. She calls on one of the local household furnishings or hardware dealers and asks to see some stoves—a kitchen range, specifically.

Now, just suppose the dealer leads her to a handsome six-hole, blue-steel affair, shining and attractive to the eye, and says:

"Here, madam, we have the greatest cookstove in the world. It will bring ice-cold water to a boil in five minutes and at the same time it has such a sensitive, variable-temperature heat adjustment that you can place a kitten on top of the stove with a hot fire going without danger of scorching pussy's footpads or singeing his whiskers. Wonderful stove! Instantaneously adjusted to any temperature—warm, hot, red-hot or white-hot. Why, you can drop a piece of asbestos, which you know is fireproof, any place on top of this marvel when it's going at its best and cause the heat-defying stuff to curl up its toes in agony like a fresh slice of bacon dropped into an extra hot frying pan. Yes, ma'am, this is, without doubt, the most unique and efficient cookstove to be found anywhere between Hudson Bay and Cape Horn!"

"But," madam will question, "how does it bake? That's what I'm interested in mostly. Of course I want a stove that is a good cooker, but at the same time it must bake well. I want to know about the oven—how well it will hold the heat and maintain a uniform temperature; how long it requires for it to warm up; whether it throws the heat from all sides or from just the top—and all about it. You see, I have a family to look after and have bread to bake, not to mention cookies, pies, cakes, roasts and no end of things to be prepared in the oven. To me the oven is the most important feature."

Do we hear someone ask: "What's that got to do with selling the farmer on belt power?" Thanks; glad you mentioned it.

AS AN illustration it has a lot to do with selling the farmer on belt power. The stove dealer whom we created for the purpose of the example is just like the tractor dealer who sells tractors merely as drawbar machines for pulling plows, harrows, drills, binders, etc. These dealers overlook the fact that the belt pulley of a tractor is just as important a part of the machine as the drawbar, if not more so. It bears the same relation to the tractor as the oven does to the kitchen range.

Madam was interested in the baking capabilities of the range just as much as in its surface cooking efficiency. If the dealer should fail to convince her that the culinary implement he had for sale would bake to

## By B. J. PAULSON

just as good advantage as it would cook, she'd march right across the street to the store where she could get a range that would cook and bake equally well.

Same way with a tractor. To-day when a farmer comes in to buy a tractor he is learning to be just as canny about the belt pulley as the madam is about the oven of the kitchen range. The farmer has grain to thresh, silage to cut, corn to husk or shell, wood to saw, hay to bale—tasks that a tractor will handle to excellent advantage—but *not with the drawbar*. The tractor dealer, therefore, should be well-versed in belt-pulley mechanics and able to explain to his prospective tractor customers the good points of the particular pulley with which his tractor is equipped.

But the big advantage of a belt pulley as a tractor selling proposition is to use it as an argument to sell the farmer who is not particularly interested in tractors—*sell him on belt power*. In every community there are many farmers who figure that they have been getting along very nicely with horses ever since they can remember—and their fathers and grandfathers, too—so why buy a tractor to perform work that can be done just as well with horses? (They refuse to recognize the economy of tractor operation and the greater efficiency and tirelessness of the tractor.) How are you going to sell a tractor to this type of farmer? How are you going to arouse in him a keen desire for the possession of a machine that he is "dead sot agin?" The answer is, *sell him belt power!*

PERHAPS this seemingly hopeless "prospect" has a large acreage of grain and depends upon custom threshermen for his threshing. He has had possibly the experience of long delays waiting for the threshing outfit when he was ready—perhaps held up by an extended run for some neighboring farmer or an unavoidable breakdown. He may also have had the experience of paying what he considered prohibitive threshing rates to the custom threshermen, making a big hole in his profits. Perhaps he has had bitter quarrels with the neighborhood threshermen and dislikes engaging them to thresh his crop just as much as he'd dislike having good teeth pulled. It may be that he has suffered grain losses because of poor threshing—any number of such possibilities.

The tractor dealer, by exercising a little tact, can learn all these facts and convert them into tractor selling capital. With a tractor at his disposal—and a *small thresher*—the farmer could thresh his crop whenever he might be ready—no exasperating de-

lays. And he'd save for himself the profits that the custom thresherman has been earning through threshing his crops. At the same time he'd have the satisfaction of knowing that the job was being done right—that all of the grain was being put into the sacks or granary and not into the straw pile.

A little tactful argument along these lines, and before he knows it the dealer sells his prospect not only a tractor but also an *individual thresher*. He is most assuredly killing two birds with one stone. And he does it by capitalizing *belt power*.

Or the prospect may have a large hay acreage—hay that would bring high prices in outside markets. All the farmer requires is a hay baler—which he can operate with his tractor—with which to bale the hay for shipment. Of if he believes in keeping his hay under cover and thus conserve the elements of nutrition a baler will enable him to put five times as much hay into the same space that loose bulk hay would occupy. A little diplomatic suggestion now and then by the dealer bringing out the advantages of a hay baler that could be operated during "off seasons" when other work is slack, and it will be only a matter of time before the prospect will begin to weaken, then ask the price of a baler—and buy both a *baler and a tractor*.

Every farmer has need for belt power in some form, whether it be for threshing, hay baling, grinding feed, cutting silage, husking and shelling corn, sawing wood, etc. And each need represents possible sales of tractors—sales that can be effected by featuring the tractor's belt power efficiency. And, as has been shown already, a tractor sale in such cases also means the sale of a belt power machine to go with the tractor.

AND quite aside from selling tractors, belt power enables the live dealer to work up a good trade selling power machines to farmers who already own tractors. The average tractor stands idle six months or more during the year. While idle it represents dead capital—an investment upon which the farmer is losing interest and depreciation without producing revenue to offset this expense. But—with belt power equipment, operating by the tractor, the idle days can be transformed into busy, profitable days whether working for the farmer individually or rendering service to other farmers in the community in some form of custom work.

The next time you try to sell a customer a tractor, think about the kitchen range without an oven—and what a tractor would be without a belt pulley. As Shakespeare would say, if he were with us to-day, "The pulley's the thing!"



The Story of Motor Sales Co's. Success in Halifax

# BUILDING N.S.'s. BIGGEST AUTOMOTIVE BUSINESS

THE MERCHANDISING of motor cars, trucks and tractors is very similar to that of any other commodity—strictly a matter of building up an efficient business organization, and conducting it along the usual, common-sense business principles.

This is the practical statement enunciated by Frank A. Gillis, president of Motor Sales Company, Limited, Halifax, N. S., who for ten years has been engaged in the merchandising of builders' supplies in the Maritime Provinces, and calls his automotive business a "side-line."

"Personally," says Mr. Gillis to the M. I. T., "I am absolutely new at the motor vehicle business, and although we have the largest motor business in the city of Halifax, and possibly in the Province, it is a side-line with me. I have sold builders' supplies for ten years, and I make this explanation to show that motor vehicles can be merchandised successfully the same as any other commodity.

"The successful marketing of the Cleveland Tractor, for example, was through no personal effort of my own, but owing to an efficient staff of salesmen and sub-dealers' organization, obtained by process of patience rather than elimination.

"WHEN I SAY it was obtained by 'patience rather than elimination,' I mean that I preferred waiting for the right man to handle my goods rather than place the marketing of them with anyone that applied, and who had a prospect or two. It has been my endeavor to get as representative men who have standing in their communities for fair dealing; men who would not make rash statements, knowing that neither they nor the machine could back them up; men who could swing the deal and give the necessary service, both by carrying parts and looking after customers; and men financially responsible in every way.

"My one particular instruction to a sub-dealer or salesman has been that under no consideration would he try to give a demonstration where conditions were not right, as I saw salesmen of some other concerns were trying to do the impossible with their machines, and in consequence were giving a black eye not only to their own tractors, but also to tractors in general.

"In Nova Scotia there are about six counties that are really farming districts, and in these different counties we have placed sub-dealers. These sub-dealers pay us cash for the machines as we ship them out; in several cases these men are also doing a general store business, and they in turn get a fair proportion of cash, and the balance by note, payable when the farmer harvests his crop.

"THESE LOCAL dealers arrange credit for this with their bankers, who are only too glad to have this sort of paper, realizing that a farmer who buys a machine of this character and cost has given the question considerable thought, and undoubtedly will increase his production sufficiently to pay for the machine in one season. This is particularly true in this Province, where the season between frost out and crop in is probably the shortest of any Province in Canada; without a properly prepared seed-bed the crop at many times has been an absolute failure.

"We also find that in many cases the boy who has returned from the front has gone on the farm, and insists that he must have motive power in order to face the prospect of breaking soil that has gone unbroken for the past four years. Where the Cletrac has in three different cases plowed ten acres in seven hours, operated by the farmer himself, it is rather a



Photo by International Press  
FRANK A. GILLIS.  
Government statistics showed Nova Scotia as the proud possessor of 43 tractors at the end of 1918. Mr. Gillis' organization sold 47 tractors in N.S. in 1919.

good selling proposition, because back of it is what I consider the one essential—first-class service. Thus I consider the future of the tractor in this Province most roseate.

"All credit should be given manufacturers who stand behind their machines. This has been done by us, even to the extent of adding new improvements to old machines, without charge to the owner. A service man, as well as a salesman, is kept continuously on the territory."

Nineteen nineteen was the first year that Mr. Gillis had the agency for the Cletrac, and they are particularly pleased that they disposed of forty-seven tractors before the end of the year. In Nova Scotia alone Motor Sales Company confidently expect to sell 100 tractors during 1920.

the policy, and if the facts show that the car was not in the possession of a thief, then must pay such damages as may be assessed against the owner.

"By keeping clearly in mind what the policy of insurance is there will be no doubt about the extent to which the company must cover the owner."

## THE LAW ON LIENS

A QUESTION that has frequently arisen is: "What is the right of a garage to retain possession of a motor vehicle for the costs of repairs, accessories, etc.?"

The solicitor for the Ontario Motor League, replies as follows:

1. By common law a garage owner is entitled to a lien upon a car for labor supplied upon it, or parts furnished for it, and this lien he has the right to enforce by retaining possession of the car until paid.

2. The lien and the right to possession ceases once the owner is permitted to remove the car from the garage.

3. Even if the car is returned to the garage subsequently, the lien does not re-attach, unless it was previously agreed that the lien should continue, notwithstanding the removal of the car.

4. No lien and consequently no right to retain possession arises at law in respect of charges for storage or accessories supplied.

Katzman & Mannie, 16 O. W. N. 362.

Automobile Supply & Hards, 28 O. L. R. 585.

## AUTO PROPHECIES

A WRITER in *Motor World's* mammoth winter number has some interesting forecasts regarding the future of the automobile—the growth, improvements, etc. He prognosticates that:

We shall soon see the "after the war" cars that it was impossible to make in 1919.

There will be no immediate fall in prices.

Twelve new companies are entering the field.

Most new cars are forced to list at more than \$1,500.

Enclosed cars will replace present open models. There will be at least 15,000,000 cars in use by 1925.

Motor vibration is becoming ancient history.

Oiling methods permit higher speed.

Small motors will be more numerous—and give more power.

As motors grow smaller bodies will become roomier. Bodies may change materially.

Primers may become stock equipment.

We shall see aluminum wheels.

New materials will be used in manufacture.

New methods will be found for handling present materials.

Steel may be made twice as strong as now, effecting lightness.

Higher grades of workmanship have resulted from the demands of war.

Cars will be studied from a sales and up-keep point of view by the engineer.

Good roads will be the greatest development of the next few years.

The business is passing into the hands of a few—and will probably stay there.

## Legal Cases of Interest

### INSURANCE PROBLEM.

T. N. PHELAN, solicitor of the Ontario Motor League, writes in the *Toronto Sunday World* as follows:

"I note my opinion is quoted with reference to the liability of an insurance company to indemnify a policy-owner in case damage is done by a car which was stolen from the policy-holder.

"In nearly all these policies the obligation of the company is to indemnify the owner "against loss from the liability imposed by law upon him" for damages for bodily injuries or for the destruction of property.

"It follows that if the car causing the damage is in the possession of a person who has stolen it, that there is no liability imposed by law upon the owner, and, therefore, no liability for the insurance company to assume, but in all these cases the question of liability or no liability is usually fought out and determined in the courts and the insurance company must, without a doubt, defend such action according to the terms of



Left to right: Tracey Walker, implement agent (this man died since); Hudson Grant, representative farmer of the Malmo District and a very successful one; E. L. Fenton, farmer, of Wetaskiwin, who has taken a great interest in race horses and who has gone in for power farming; Mons Dyberg, one of the largest farmers in the Wetaskiwin District; G. A. Ferguson, a farmer of the Malmo District who has also gone in for power farming on a large scale.



# He DOFFED His DIRTY DUNGAREES

Riddel Made More Money Wearing a White Collar

By G. H. SALLANS

FROM a "one-horse" blacksmith shop in 1912 to one of the most modern plants in Saskatchewan, in 1919, is the speedy romance achieved by the big carriage and motor works in Saskatoon, owned and operated by G. G. Riddel. But Mr. Riddel's story is not one of romance. It is rather one of hard work, whole-hearted enthusiasm, and a constant reaching out for bigger and better things, which, coupled with ingenuity and not a little imagination, has brought him to his present place.

As will be seen in the illustration, the new building is built on the corner, adjoining the old one. The plant is one of Saskatoon's best business streets, and has been the centre of activity ever since the first building went up. In 1912 he started; in 1913 he had a good business in blacksmithing and a coming industry in carriage repair work. In 1916 he gave up the forge, employed more and more men to fill up his growing plant, and applied himself solely to the business end of it.

Therein is the first point in Mr. Riddel's discoveries, that a man must do business, and business alone. He can not stick at the forge and meet his customers, his salesmen, his business acquaintances, in a coat of grease and grime. He must look the part he is playing.

THE new building is 75 by 52 by 35 feet, with three floors; and the old building measures 75 by 90 feet, giving him a total of 18,490 square feet floor space, of which 10,690 square feet are on the street level. While the big plant is equipped for all sorts of garage work, his specialty is woodwork and upholstery, and there is nothing in this line he cannot undertake.

On the ground floor of the old plant are all the machines used in carriage repair work, all run by an electric motor. They are arranged compactly, yet are so placed that the longest plank will not be in the road of any machine.

To the rear of the repair room is a large warehouse and store room, in which he has a stock of various woods, wheels, rims, spokes, everything that could be used in carriage repairs; more stock than all the rest in the city added together.

BESIDE the store room, extending to the same depth, is the upholstery room, fitted with two stout sewing machines, and a long table, on which all the work is done. On either side, extending the full height of the walls, are shelves, in which are packed every variety of upholstery, even to the coarsest material used in rain-proof tops. A door from this room leads directly into the repair room, so that a car can run straight in from the street entrance, be repaired, go straight ahead into the upholstery room, back into the garage in the main building, and thence through the exit door; or vice versa.

To go back to the repair room: Here we find the machinery in orderly array—lathe, drilling machine, sand-drum and sand-belt, screwing machine, heavy upsetter, shaper, tenoning machine, two buzz planers, rip saw, band saw, jointer and planer, vertical and horizontal wood boring machines, and motor shaftings.

The body department is next all the woodworking machines, and near that is the joining department, where bodies of any kind are made—commercial, delivery, truck, auto bus, cabs, ambulances, Ford racing bodies

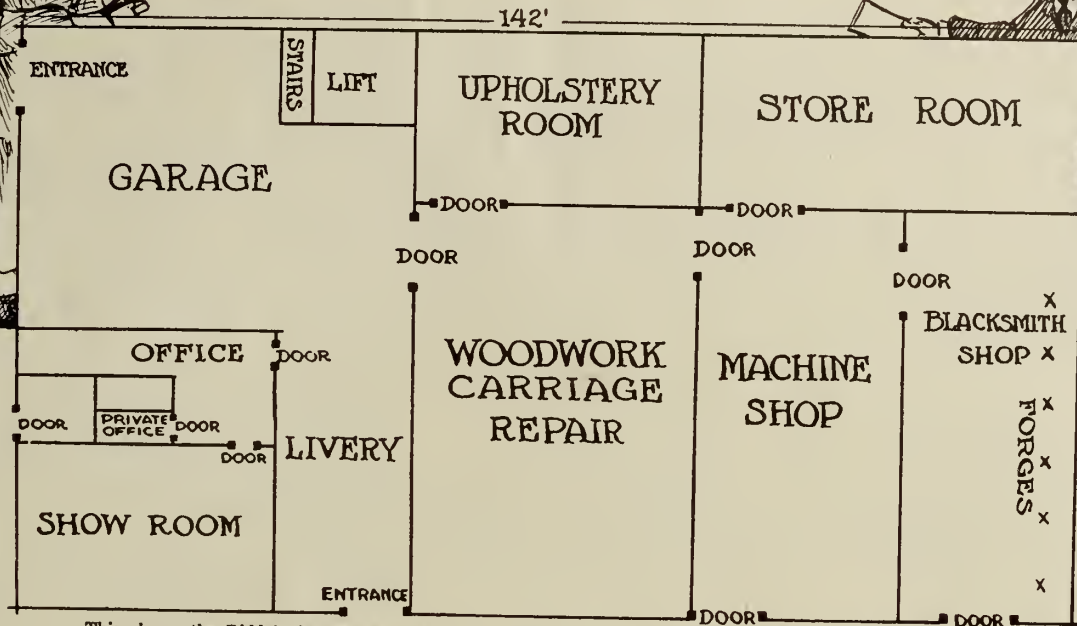

This shows the Riddel place as it is laid out to expedite work, and facilitate its routing through the plant.

— anything that can be put on a chassis. Going on from there to the upholstery, is found everything in that line—tops, windshields, cushions, curtains, plate-glass lights, auxiliary side windshields, seat covers, radiator covers, and tire covers.

In the new building, ground floor, is the garage, with showrooms and office in front, facing on the street, and lighted through two immense show windows. Floors here are of concrete, and automatically drained. The building being on a corner, wide doorways face on each street, one the entrance and the other exit. In the rear corner is the lift, capacity five tons, driven by a five-horse-power motor. The lift is Mr. Riddel's own designing, and presents a finished appearance equal to a \$3,600 installation, although its total cost was little more than \$600. Beside the lift are the stairs.

Stepping from the lift on to the second floor, an immense work bench stands to the right, in the corner, and the entire floor space is available for repair work on cars. Next the bench is the stock-room, where all parts are collected in shelves, and classified, thus eliminating all confusion and waste of time. The only obstructions are the giant 24-by-10 beams, which run the full depth of the building, supporting each ceiling with absolute security.

THE THIRD floor is given over entirely to paints and varnishes. In one corner is the varnish room, thirty by fifty feet, made of two-ply boards,

till night. A row of twenty rings was constantly occupied. To-day every ring in the shop is rusty with disuse, while on the opposite side is a startling array of horseshoes, all getting rusty. The motor has supplanted the horse; but the business of the blacksmith shop is, nevertheless, as heavy as ever, if not heavier.

It is up to date in every respect. Electric blowers keep the forges going. A cold tire setter, an emery wheel, a threading machine, a tire shrinker, a cutter and punch, are the principal features in the blacksmithing machinery worked out to a system.

In business Mr. Riddel has insisted upon system in all departments. He learned the value of this when he left the forge, doffed his greasy overalls, put on a white collar and started in to save through management about nine times as much as he was saving by working himself, instead of hiring help to take his place. This at any time would have taken two men at least.

"I used to supply my employees with all the dust-rags and waste they wanted. It was always there, and they could get it whenever they wished. I found they always wished. Now I don't supply them with a single rag; and they get along just as well. Rags, when multiplied by several thousand, cost money. Oils of all kinds are the same. Supply them free, and you'll always have to supply them. Hundreds of dollars in oil are wasted in this country every day through this lavish system. But not here. It costs too much." Thus Mr. Riddel sums up the situation.

IF ANY employee wants anything whatever, he has to sign a requisition. In this way an accurate record of everything given out is kept in the office.

The big plant is steam-heated throughout by a large plant in the basement, with jacket tested to fifty pounds, and carrying thirty. On each floor of the new building are twelve radiators, so that cold is not to be thought of.

Light is abundant, both during the day and night. Skylights in the old building, and large show windows in the new, make ample provision for sunlight in the daytime, and at night each floor is lighted by eighteen electric lights, each of 100-candle-power. Throughout the interior is kalsomined a bright color, which makes a hundred per cent. difference to the lighting facilities.

In the busy season the plant keeps twenty-five men busy, and never less than eighteen are employed, even in the slackest months. At present Mr. Riddel has openings in the painting line, though for finished experts only.

beaver board inside lining, ceiling plastered and the whole hermetically sealed and thoroughly dust-proof. The third and second floors are hardwood throughout.

The roof is tar and gravel, and one-way slant.

Business romance is not generally connected very closely with blacksmith shops, but with this one it is. The history of that portion of the establishment is remarkable. In 1912 Mr. Riddel started with two forges. In 1914 he had four forges, employed six men in the shop and carriage repair room, and worked the first forge himself. Between 1914 and 1916 his average monthly business was approximately \$3,000. But he had not a moment to himself. As he himself says, he worked so hard it took the heart out of him for anything else.

In those days the shop was full of horses from morning



This shows the commanding position of the Riddel Building in Saskatoon.



# Plan Your Business Intelligently For 1920

WARREN McBRIDE, who has been doing a huge repair business in his garage, Pears Avenue, Toronto, is an auto man who has ideas—worth while ones. Recently when asked for his 1920 plans, he said:

"Since you have asked me to tell you of the preparations I am making for the 1920 season, it is really best to tell you first just why I am making any preparations at all. Well, in the first year of my career as a tire dealer, I just drifted along like many other fellows, trusting to luck that I would be able to conduct the business, and meet conditions as they occurred. Frankly, if competition had been as keen that year as it is now, I should have lost every cent I had. But the field wasn't crowded, and I managed to get through the year with a fair balance on the friendly side of my profit and loss sheet. But at the end of the season I felt that I should have had a better profit, so I sat down and gave a couple of hours to reflection on the way the business had been run.

"One of the first things that occurred to me was that a good deal of my time was unnecessarily taken up with untangling mix-ups which resulted from the loose manner in which my stock and accounts and other divisions of my business were running. For instance, I was not keeping daily stock records, and very often I lost customers because I unknowingly let my stock run completely out of some urgently needed article; and when salesmen called I had to go over my entire stock to see what I needed, and usually I would forget to order if there were not one or two articles left to remind me; and when a customer asked for a statement of his account, I could not give it to him for a week or more.

"See why I wasn't making enough profit? It is quite clear. The time I should have used for aggressive efforts to increase my sales was being taken up by these tangles; and the profit I was making was being eaten up by the inevitable leakage of a loosely-conducted business. I will not bore you with details of my reflections, but the result was that I resolved to always lay out my plans for the coming year's business.

"SOME of my plans for 1920 are new; others are renewed. A summary of what I must do next year to make a good showing against the higher class competition we now have is as follows:

"1. I must have good tires, tubes and accessories to sell.

"2. I must plan a Service programme which will assure my customers satisfaction from their tires, so that I may retain these customers.

"3. I must let prospective customers know that I have for sale their tire necessities, and I must sell them the goods that I have.

"4. I must have a proper bookkeeping system.

"5. I must have up-to-date stock inventories.

"These features are named in order of appearance, rather than in order of importance. Each is equally important, and each depends on the others for its success.

"In choosing a line of tire products to sell, I decided that I would handle one good line exclusively, because this should simplify my stock problems, and make my selling more consistent. I turned over in my mind the different good lines on the market and finally decided on a line,—not *entirely* because I believed it to be highest in quality. If the features that accompany this line were taken from it, and attached to a slightly inferior line, I would choose the latter. Fortunately, the line I considered highest in quality had also the merchandising policy attached to it, which I knew to be necessary to enable me to carry out the remaining four features of my plan. The proposition which was presented with the product I chose gave me the all-important assurance that my fair profit would be protected against price-cutting, hidden competition by special brands, and by manufacturer-to-consumer selling. In short, the proposition was essential to the remainder of my program, and by coincidence,—due to a common purpose,—my programme was in accord with the undertaking required on my part in handling the line.

"By the way, you may wonder why I list Service ahead of selling. The answer is that my Service programme is just as much my stock-in-trade as tires,—I SELL SERVICE. And, of course, I must provide Service before I can sell it.

"SERVICE has been called everything in the criminal code from petty larceny to high treason. But it isn't any of those things. I have learned to have a high regard for that feature of business,—the name of which has been so profaned. That's human of me.—Service has brought me much good business, so I should hold it in high esteem. I have a pet definition for Service,—'The lubricant of the selling machine.' Without Service your selling will burn itself out. With genuine Service your selling will run smoothly

and will generate greater power as it goes. I plan to give the following Service to my 1920 tire customers:

"The prime motive of Advisory Service is to act as a trouble preventive. First of all, I will tell each customer of the tire's capacity to deliver mileage, and of its limitation. The customer will be told that the tire he buys is warranted by the manufacturer to be perfect. The capacity of the tire to deliver mileage will be in measure with the customer's willingness to get from it all the mileage that is built into it. The tire's only limitation will be the owner's neglect to give it a fair chance to do its work. To give his tires a fair chance, each customer will be advised to watch the wheel alignment, the inflation, the load, the brakes; to avoid sudden starting and stopping, reckless turning, severe road shocks, and misuse of chains; and to promptly attend to tread cuts and necessary repairs.

"Of course, the best way to get a man to practice what I preach to him is to make my doctrine practicable. So, I'll have the 'Free-Air' signs out,—test each customer's wheels and brakes occasionally,—and (here is where I fool the something-for-nothing idea) I'll sell tire saver kits and pressure gauges and take in the repair jobs, even if I have to send them out to be done.

"My next problem is to sell the tires I have chosen and the Service I have provided to prospective customers. First, to put it simply, I must let all my prospects know that I have the tires and the Service which will give them the low cost-per-mile and the uninterrupted Service which they desire.

"BESIDES my general newspaper advertising, I am going to have more direct, more personal messages go to the car owners in this district. These will be mailed at regular intervals. They are the most effective substitutes for personal calls on customers that a dealer could use. I say that confidently,

## Made Record Separator Sales

"I HAVE been covering the same territory for the last four years," said Mr. MacQuarrie, "and I find that cream separators can be sold as readily in August as they can in June. Right there is where many dealers make a big mistake. They count



C. H. MacQuarrie, Fredericton, N.B., winner of the first prize, a 4 h.p. engine valued at \$315 given by the Renfrew Machinery Company to the dealer selling the most Renfrew Separators during 1919.

on March, April, May and June as being the months when cream separators are in greatest demand. I have found from experience that the dealer who works his territory all the year round gets the best results. I sold two machines on the 31st day of December last. February and August were, I think, my best months. Many will tell you the farmer is too busy in August to talk to you. It is during his busy time he feels the

because I have used the direct mail messages in previous years and know that they produce sales.

"At some time during the season I may want to make a special sales 'drive' on some particular article or line. My experience in this regard has shown me that direct mail advertising has an important part to play in such a sales 'drive.'

"This big show window in front of my store is another feature of my sales effort. It is admitted by all successful merchants that good window displays bring passing customers in; and as someone has said, 'Goods well displayed are half sold.' I am going to use all the suggestions and helps for making good window displays that the manufacturers offer me.

"When my advertising and window displays have brought customers into my place, I am going to make sure that they are well received and that they buy their tires, tubes and accessories from me. I believe many tire dealers get people coming to their stores and then neglect to take advantage of these opportunities to increase sales. Of course, we will not bother the life out of every one who comes in to make him buy something. I have a man who will serve gasoline, oil and air, and do other service work. This man becomes acquainted with my customers and their needs, and when he notices that they need spare tubes, patches, tire putty, or other accessories, he can suggest to the customers that these tire-savers will add to the mileage of their tires and he will sell the customers these articles. I am confident that this service salesman will sell enough accessories to make this division of my sales quite large and profitable.

"THIS service salesman will also sell tires. I have trained him to know the qualities of the tires we sell and to know also the necessary conservation advice which should accompany each tire sale. In selling tires this man will also sell our customers on the Service we have provided to ensure entire satisfaction and low-cost-per-mile from the tires. With this combination of selling—quality and service—we have not much to fear from cut-price or low-quality competition.

(N. B. The bulk of this article by Mr. McBride appeared in *Goodyear Tire News*, to the editor of which M. T. I. is thereby indebted.)

need of labor-saving machinery. If your machine meets his requirements he is quicker to close a deal, as time is then an important factor.

"Many of my sales are the result of tips given me by my old customers: I aim to have every customer a booster and it is wonderful how it helps sales. My interest in a customer does not cease when I sell a separator. I make it a point to call when possible, make any little adjustments necessary, and to see that they are thoroughly pleased with their buy. This extra service is highly appreciated and I am often rewarded by being told of neighbors who are in the market for separators.

"I'm a firm believer in tying up with a progressive house—who put their very best into their products and who back you up with live publicity. The farm paper advertising done by our company reduces the resistance in selling to a minimum. When farmers tell you they saw the separator advertised in their farm paper and are familiar through that advertising with the strong points of the machine, much of the missionary work is done. Advertising in local papers also helps.

"TOO MUCH time cannot be taken to impress on the customer the importance of proper oiling and cleaning the separator. The dealer who does this is doing much to insure a repeat sale later. Machines are sometimes scrapped at the end of two or three years and other makes purchased through no fault of the machine, but through the ignorance or carelessness of the customer. This reacts to the dealer's disadvantage, whereas a separator giving satisfactory service for eight or ten years is selling itself to neighbors in that community.

"And don't overlook the importance of the farmer's wife when selling a cream separator. She is his business partner, very often the head of the dairy department, and in many cases the banker. When she is sold the deal is more than half-closed. I have sold several separators to farm women without having to spend time in going to the field to interview the farmer."



## SCORES OF WINDOWS AND NO PILLARS

# Feature Webber's Garage In Calgary, Alta.

**W**INDOWS everywhere and pillars nowhere—such are two of the main features in Webber's Garage, which was opened in Calgary last June, and has since been doing a capacity business. Several of those chiefly responsible for the success of the business are returned soldiers with splendid war records.

George Webber, the proprietor, knows the garage business from A to Z, and has more than a Provincial reputation among the auto fraternity. He knows how to pick men, too. At the end of the year the foremen and employees of various departments received substantial bonuses, according to the profits of their departments. This system has been found to ensure super-efficiency.

Situated on the south side of Fifth Avenue, between First Street West and Centre Street, the building is away from heavy through traffic and still within three blocks of the exact centre of the city. It is of the most modern fireproof brick construction, two storeys, measuring 50 by 140. The front of the building, housing the offices and accessory department, is 65 feet wide.

**T**HERE is not a pillar or post in the building. Their absence greatly increases the amount of available space and facilitates the movements of cars. The ground floor of concrete is the finest in the city, being very carefully laid so as to avoid puddles. There is a slight slope toward the sides of the building, drain troughs being along the walls. Over \$350 was spent in giving this floor a thorough acid treatment, which has made it extremely hard and impervious to all liquids. It is so hard that blows with a hammer fail to make any mark on it.

A modern hydraulic elevator is set at an angle in one corner at the back. This elevator, which is of large capacity, is so conveniently placed that it requires no maneuvering to get a car or truck on it, as is the case with so many garage elevators. Webber says it is guaranteed not to get "out of order."

Webber's experience as a garageman again manifests itself in the unusually adequate lighting of the building, both upstairs and down. Windows are everywhere. Walls are kalsomined white, and will be kept fresh and clean. Light is essential to good mechanical work of any kind, especially in getting at awkward spots in a motor car, and light is surely provided. In addition to a modern overhead night lighting system, extension cords are everywhere in evidence for night work or inspection. There must be over thirty-five of them in Webber's.

**I**N FRONT of the building there is a paved space where motorists will take on fuel and oil and be furnished with free air and water. The facilities provided are sure to be appreciated by all car owners. Everything is in duplicate so that there will be no waiting. One big curb pump delivers five gallons of White Rose gasoline at a shot. A few feet away is another pump which serves the same quantity of Red Crown gas. There are two pumps which serve the best brands of motor oils in exactly measured quantities; two sets of air and water lines for curb service. This curb service will be kept brightly lighted at all hours, according to Webber. Gasoline and oil pumps are also installed within the building, air and water as well.

A feature of the ground floor is the convenient toilet facilities for men as well as women. The ladies' rest room is especially attractive, being fitted with comfortable chairs. Late magazines are provided. The washrooms are tiled and are of ample size. Such conveniences are much appreciated by tourists as well as motorists in the city.

Webber has evidently tried to live up to the motto which he set forth in this city over three years ago: "Everything for the Motorist." First mentioned is the accessory department. This is an attractive room facing the street, stocked with all that is approved in the way of supplies for the motor car. Jimmie Bell is in charge of this department. Tires, tools, touring and camping equipment are some of the things which may be purchased in the accessory shop.

**U**PSTAIRS is the vulcanizing room, the battery plant, radiator repair plant, the machine shop with its tool room, and the repair shop. Each of these de-

partments shows the results of very careful study. Things are so well arranged and so well lighted that it should be easy to turn out good work.

The battery plant, in charge of Albert Dyson, employs one of the new Tungar rectifiers for charging purposes. This is the last word in battery charging. Perfect equipment is there for the complete repair and rebuilding of batteries.

The radiator shop is just as modern and just as complete. Testing tanks, gas and compressed air are placed with an eye to convenience and efficiency. Ed Desutter is in charge of this department.

The tire shop is ready for all kinds of tire work, tube repairs, sections or retreads.

In the stockroom Frank Donnelly has a complete line of Ford and Chevrolet parts, as well as other standard fittings for automobiles.

In the machine shop, which extends across the north end of the second floor, brand-new equipment of the finest pattern and quality has been placed. There are lathes, drills, emery wheels and other standard shop equipment. But equally important, Webber has secured the latest devices for putting through Ford and other repair jobs quickly and well. For instance, he

has one of the new outfits for burning in Ford bearings. These machines are great labor-savers, besides doing better work, and since they were marketed a few months ago most of the big shops in the States have installed them. Webber read of them in a trade journal and ordered direct from the factory. He doesn't seem afraid to spend money to get results.

In the machine shop is installed the air compressor (incidentally the largest in the Province) and a great steel air tank built specially for Webber here in Calgary. This tank is tested for 250 pounds' pressure, and a pressure of some 200 pounds will be maintained day and night the year round.

The floor is entirely clear of obstructions in the repair department. Each workman has his own bench with lock drawers, obviating confusion and consequent loss of time. Each car stands over a pit, if pit work is necessary. In the pit is an extension cord for light. At the wall beside every repair stall is a long air line with nozzle, used for blowing dirt out of parts. Overhead is a travelling crane the entire length of the shop, carrying three chain tackles. With this unique equipment only a moment is required to raise either end of a car undergoing repairs.

## Renfrew Holds Annual Banquet



Dealers and members of the Renfrew Machinery Company who attended the three-day convention at Renfrew, Ontario. The convention was the most successful one in the history of the Company.

**T**HE annual convention of the Renfrew Machinery Company was held at Renfrew on January 6, 7 and 8, and was attended by travellers and dealers from Ontario, Quebec and the Maritime Provinces. C. G. Rose, general sales manager, presided. In his opening address he welcomed the visitors to the head office and referred to the satisfactory business done in 1919. He dealt with the programme outlined by the company for 1920—the biggest and most comprehensive ever planned by the company. He urged dealers to improve their sales organization so as to get their share of the increased trade which will go to the live, progressive dealers in 1920.

A notable feature of 1919 sales, he said, was the large number of dealers who ordered separators and scales by the carload. The company were anxious to see more dealers doing business on this large scale, and were spending thousands of dollars in farm and dealer paper advertising and dealer helps, to develop business on a large scale.

After the general meeting the convention was subdivided into three sections—Ontario, Quebec and the Maritime Provinces—to discuss their individual problems. The three sections were presided over by the sales managers for the respective fields, C. J. McMahon for Ontario, H. M. Vigneux for Quebec, and E. H. Vickers for the Maritime field.

**A** TOUR was made of the manufacturing plant and dealers had an opportunity to see for themselves the Renfrew plant.

On the evening of the sixth a smoker was held at Hotel Renfrew. A special attraction was staged at O'Brien's Theatre the second evening for the entertainment of the visitors. The convention was closed by an excellent banquet given by the company at Hotel Renfrew. N. L. Murray, vice-president of the company, was the toastmaster, and addresses were delivered by leading speakers. During the evening

the prize winners in the 1919 sales contest were announced by General Sales Manager Rose. The winners were as follows: J. S. McCann, winner of the \$500 supreme prize; J. Hagerman, winner of a 3 h. p. engine valued at \$210 for the sale of the greatest number of scales during the year; A Bureau, winner of a 3 h. p. gas engine, valued at \$210, for the sale of the greatest number of engines; W. H. Sutherland, winner of a 3 h. p. engine, valued at \$210, for the largest volume of sales in the Maritime Provinces; C. H. MacQuarrie, winner of a 3 h. p. engine, valued at \$210, for the largest number of separators sold during 1919.

### USES FORD YARNS IN ADS

**M**EDICINE HAT, ALTA.—M. A. Corey, of the Central Garage, is using a Ford story in each of his display ads, which he runs in the Medicine Hat dailies. Here is one—just a sample, not the best by any means—

#### A NEW ONE EVERY DAY

Beat it, beat it, little car,  
How I wonder what you are,  
Climbing up the hills on high,  
Passing all the others by.  
As it passed the first man fussed,  
While the second mildly cussed,  
But the last man yelled and roared,  
"You can't stop it—it's a Ford."

The ad. is headed "Daily Ford Story," and underneath is a little hint, as: "Do you grind feed? Power attachments for Ford cars. Saves the price of an engine."

In discussing this novel ad. with the M. T. I., Mr. Corey says the idea is his own and "as a salesman the benefit is questionable, but the public certainly read the ads."



# Do You Use Your Smile In Your Business?

## C. O. BAPTIST DOES

IF you were selling automobiles or agricultural implements, and you had in your territory ten farmers or more, along one stretch of road, where each farmer was worth from \$100,000 to \$125,000, wouldn't you consider that a potential dealers' paradise?

This is a part of the territory that C. O. Baptist, of Three Rivers, Quebec, who handles McLaughlin and Studebaker cars, Cleveland tractors and Stewart trucks, has to exploit, and when you learn that last year he disposed of 140 cars you can see that he is more than moderately successful.

"It's nothing at all," replied Mr. Baptist, turning full on to the M.T.I. man the engaging smile that ripples over his countenance at every possible excuse. "I simply get acquainted with everyone who is a prospect, tell my man what a fine car—or truck—or tractor—I am selling, and then he signs the order sometimes.

"There are still hundreds and thousands of prospects in my territory, whom I am planning to sell this year, or next year—or some year after that. I could take you out to the country that lies around Three Rivers—some of the most fertile and productive farming land in the world—and give you name after name of farmers, along one single stretch of road, every one of whom is worth \$100,000 or more."

"It must be pretty easy to sell men like these," we suggested.

"On the contrary, it's not any 'cinch.' They have not been used to spending their money freely, and they have been accustomed to hoarding it, rather than investing in time- and labor-saving devices. But gradually they are changing their attitude, and before very many years Quebec will have almost as large a number of automobiles in proportion to population as any of the other provinces."

MR. BAPTIST started to sell Cletracs last year, and disposed of sixteen, practically all for industrial purposes. The work they are doing is to some extent still in the experimental stage yet, but shows infinite possibilities. Almost all the sixteen were sold to lumber companies, who are using these tractors to haul out the logs during the winter. Six were sold to the Wayagamack Co., three to Laurentide Paper Mills, one to the Rat River Co., and so on.

Logs are being pulled out from Flamond Creek, along a special road on which \$10,000 in improvements has recently been spent, over a twelve-mile stretch. At present each tractor is pulling two sleighs, with a load of from 120 logs or more. It is hoped that within a short time improvements will be made which will enable each tractor to pull as many as 200 logs, each machine thus displacing several horses, and doing the work at a time and in places where horses could not be satisfactorily employed.

"I am always glad to place a tractor at the disposal of any industrial concern, for I believe that after experimenting with it they will be convinced as to its efficiency, and this will lead to more orders. Let 'em try out the tractor; they'll learn to appreciate it," says Mr. Baptist.

IT'S very satisfactory to go down the main street of a city and see mostly McLaughlins or Studebakers—that is, if you happen to be the dealer handling these two makes of cars.

"I sold nearly all of the 140 cars myself," says Mr. Baptist. "I believe that I made 125 of the sales personally, as I do not make use of sub-dealers and have no assistance in this part of the work. Nearly all the sales made were of new cars, too. As far as I can learn, the dealer who handles a certain make of low-priced car sold only eight during the season."

A smile and a laugh—in season—and a jolly or joshing word in the right place—these all help sales. As you can see by this sketch of Mr. Baptist, he has a fine, wide, all-pervasive smile—and he uses it in his business.

"You have to have the goods to sell," emphasized Mr. Baptist, "but a smile's always useful, or a good

story, or an appreciative phrase to some one who may be feeling just a little disheartened or out of sorts.

"And, after you've sold a man a car, tractor or truck, don't forget all about him. Give him the same

kind of treatment and service as you would your best friend among your customers. That's the way to make for repeat business, and make all your customers your friends."

A good receipt, n'est-ce-pas?

## Montreal Show "Big" Success; Dealers and Public Profit

THE Motor Show held in Montreal January 17 to 24 was a huge success, whether you look at it from the stand-point of the dealer or of the public. There were about sixty cars shown, including between thirty and forty different makes; more than a dozen trucks; and large displays of accessories.

Dealers reported large numbers of likely prospects obtained, and even chronicled quite a fair number of actual sales. One quietly-dressed man walked into the corner where a certain high-priced car was displayed, listened to the salesman descant on its merits for half an hour or so, and then casually remarked:

"All right; I'll take two—one closed, one open type."

The Cole Aero-Eight had a list of "Sold to —" names hung on the front of the radiator which on a final day of the show was twelve names in length. Rival salesmen claimed these represented all the Cole prospects for the whole winter, but the Cole man claimed all to be bona-fide sales closed during show week. The Essex displayed on a Sedan very prominently the sign:

"Sold to Mayor Mederic Martin."

Many other cars boasted "Sold to —" signs, also. There were no English cars shown—for the very good reason that it will be years before Great Britain will be ready to export cars. There was one British truck displayed—The Albion—which was used so largely during the war that the manufacturers have been able to get on a production basis earlier than rivals.

Similarly, there were no French cars on display, and only one Italian—the Fiat. One of the chief centres of interest was this new Fiat post-war, touring sport model, shown by the Italo-Canadian Trading Co., of Montreal, Quebec distributors. (Canadian Importers Limited, temporarily located at 1 Wellington Street West, Toronto, are Ontario distributors.) The car is a beautiful model in contour, body work and details, equipment, and in chassis. Its V-type radiator and wind-shield, straight line, stream line, hood body and mudguards, and disappearing top, with many mechanical refinements and departures, gives the car an atmosphere that is at once luxurious, racy, distinctive and distinguished. It is an aristocrat six—ninety miles per hour.

Two new trucks were expected—both Canadian ones. The one announced by the Eastern Canada Motor Truck Co.—the "Veteran"—had reserved space but had no truck at Montreal, though they announce that everything will be ready without fail for the Ottawa show the end of this month. The Maple Leaf truck, manufactured by the Maple Leaf Manufacturing Co., Montreal, attracted a good deal of attention. They announce a wholly-built Canadian truck, financed by Canadian money, and are putting four sizes on the market—running from 1½ tons to 5 tons. The truck on exhibition was a serviceable-looking machine, with neat lines, and sturdy parts.

The first Willys-Knight 20 to be exhibited in Canada was shown at Montreal. This new model has been expected for some time.

The accompanying illustration will give an idea of the general body-lines of the new cars. Hood design has been changed to one of pentagonal character,



The New Willys-Knight "20," Shown for the First Time at the Montreal Show

while the various units, the lamps, radiator, and low-slung body, are all in harmony. The chassis is one of remarkable balance. Long, flexible, semi-elliptic springs give the car an increased degree of comfort. The engine is the Knight sleeve-valve motor.

Everything possible was done by the officers of the Montreal Automobile Trade Association, under whose auspices the show was held, to further the comfort and convenience of the public. It is estimated that more than 60,000 persons attended the show, and in the evenings if arrangements for seeing the various exhibits had not been very carefully worked out it would have resulted in a jam or blockade, the crowds were so dense. Those responsible for the success of the venture are: President, J. O. Linteau, Legare Automobile and Supply Co.; vice-president, J. E. Millen, John Millen and Son, Ltd.; treasurer, N. J. E. Catudal, McLaughlin Motor Car Co.

THE Motordrome is a huge building, with 75,000 square feet of floor space contained in the three stories. The management wisely decided that the exhibits should not be classified according to floors, but exhibitors of trucks, passenger cars and automotive accessories were found on each floor, so arranged that the effect which met the eye of the observer was one of perfect harmony.

The visitor entering the show building was at once impressed with the effect. The scheme was beautiful and impressive. The entrance wood lattice work was covered with natural foliage and over the inside doorway the flags of the Allied nations were harmoniously arranged, the many colors of the decorations being sympathetically blended by the electrical decorations. As one passed into the main exhibition section of the building the effect presented is that of the Spring season blending, as one passed through the hall into Summer months. The central well, extending from the ground floor to the roof, was turned from day into night and the roof developed into a night scene with a canopy of stars. Around the galleries and side pillars the wood work was hidden completely by an abundance of natural plants in bloom and the openings into the balconies curtained. The central main pillars were covered with rich crimson and green draperies.

Regarding the cars: The greatest attention has been given to body design, to engines and to chassis detail, while clutches, transmissions, steerings and axles already highly refined, reveal but slight changes. Certain improvements, however, will be noted with respect to universal joints and to wheels, but aside from these the underneath parts of the car are virtually unaltered. This is not to say they will not undergo changes in a year or so, but there has not yet been time to permit engineers to get to every part of the car.

In looking over the new productions one was impressed with the great attention to the smaller items of equipment, to such things as door and door handles, cowl boards, instruments and fendering. For the most part designers have adhered to the basic body lines shown last year, having a high hood, usually with an angle at each side, the line of the angle meeting the top edge of the body. Hoods have more louvres, windshield supports are more substantial, and shields are much in evidence, while a few concerns have taken up small built-in side pieces attached to the windshield. This form will undoubtedly be standard equipment in a few years.

MORE overhead valve engines were seen, and those that are not new have been improved especially in lubrication. Power output is greater on the average engines, though displacement has not varied much. The fuel problem has brought about a number of changes in manifolding, and practically every engine has some means of heating the mixture. The detachable cylinder head, vacuum fuel feed, battery ignition, six-volt separate unit starting and lighting are features that have not changed.

There were some fine examples of advanced engineering, evidenced in such new practices as bearings without shims and new designs of high pressure oiling systems, improvements in valve gear, and the freer use of aluminum and other metals.



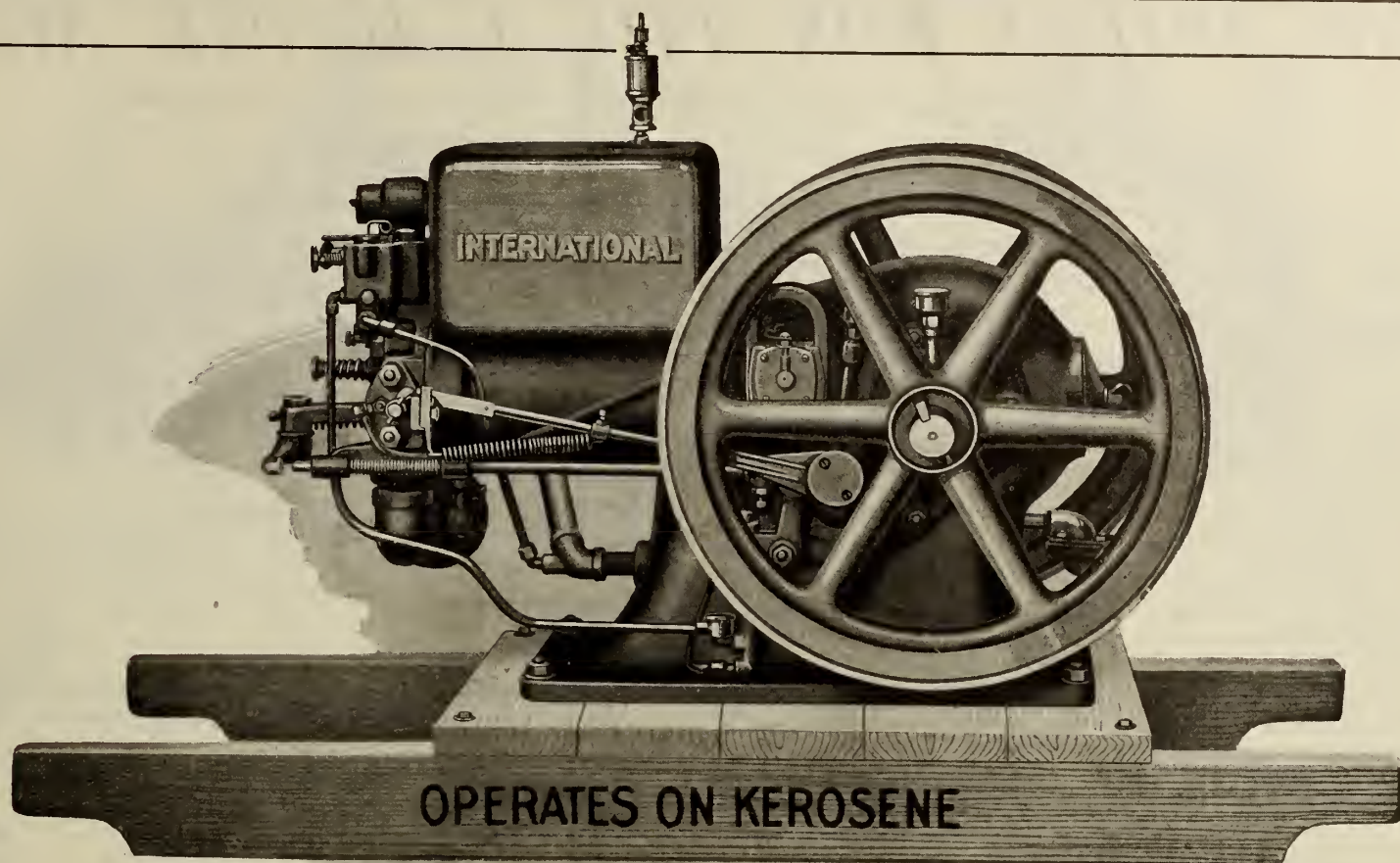

## INTERNATIONAL ENGINES

### *Little Brothers of the Tractors*

**N**EVER was there so glowing an opportunity for you to put small engines on farms as now! Labor is rare and restless—infected by the high-wage short-day agitation of the cities; money is plentiful in the farm pockets; and the drudge jobs of house and barnyard go on nagging at the patience of farmer-and-his-wife.

**INTERNATIONAL KEROSENE ENGINES** — good, sensible, long-lasting, economical in first cost and in operation—are waiting to go out to work in two dozen homes of your community. Present them as the popular power to shoulder the never-ending burdens—pumping, washing, sawing, separator turning, churning, grinding, shelling, etc. They will deliver steady, uniform power, doing better work, much faster, and more cheaply. They are made right in mechanical details and your farmers need them. There are four sizes—1½, 3, 6, and 10 h.p.

Ask the International blockman about the complete and thorough selling assistance we have ready to apply.

### INTERNATIONAL HARVESTER COMPANY

OF CANADA LTD.

HAMILTON CANADA

WESTERN BRANCHES — BRANDON, WINNIPEG, MAN., CALGARY, EDMONTON, LETHBRIDGE, ALTA.,  
ESTEVAN, N. BATTLEFORD, REGINA, SASKATOON, YORKTON, SASK.

EASTERN BRANCHES — HAMILTON, LONDON, OTTAWA, ONT., MONTREAL, QUEBEC, QUE., ST. JOHN, N. B.



# SHOP NOTES FOR THE GARAGE MAN

Where to Get Thrust Bearings—Repair Broken Mica Windows—Wheel Hub's Service

Conducted by SCOTT T. DUTHIE

## Ideas for the Automobile Man

By DONALD A. HAMPSON

**S**ATISFACTION with an auto truck or a passenger car can only be obtained by attention to little details in the matter of handling, of maintenance, and of repairs. The man whose chief claim to recognition lies in the statement of facts that he has "run a car (or worked in a garage) for five years" is twin brother to the man who "has run a boiler for years" and some of the latter fail to come back after the inevitable disaster. The garage man who "uses his head" is in the best possible position to locate mechanical troubles and apply remedies, to advise in the matter of repairs, and to drop veiled hints that will correct bad operating habits without offending.

Advice on proper methods of gear-shifting may be tactfully, and usefully

wheels, are traveling at about the same speed as the clutch and the shift is merely a movement of two parts traveling of the same speed relation and doing no relative work—just as a man may walk from one passenger coach to another of a moving train without jar to his person.

This down hill condition may be created for an instant by giving the car an extra spurt just before shifting—this supplies a momentary drifting period during which the gears may be changed without a struggle. It is so simple and so easy that any driver who has tried it wonders that he did not think of it before—it consists merely of bringing the meshing parts to about the same speeds and of then moving them while they are traveling "light."

Some drivers are slow thinkers—consequently they are poor gear shifters because they must precede each step with a mental process of the same, and meanwhile their car is losing speed. If they can be taught to push out the gear shift lever at the same time that they push out the clutch, instead of doing this in one-two fashion, they will materially improve their work. In fire apparatus work, where time is at a premium, all drivers are taught this important detail of clean, quick gear changing.

### Where to Get Thrust Bearings

**E**VERY so often, the repair man finds a thrust bearing that must be renewed but it happens to be one of those that cannot be had for a month. To tie up any machine that long for a simple part is the height of exasperation. The man with general shop experience takes a leaf out of his past, turns to a list of stock ball thrust bearings that a dozen makers and dealers carry, and phones his wants for shipment the same day. In a majority of cases, one of these catalogued bearings can be made to answer nicely; the O. D. must be ground down a little or a liner must be set behind it but otherwise this part from the machine trades is as good as the far more expensive apart from the auto maker. The auto part, however, has greater life than the other because there is a round instead of a flat raceway for the balls.

### Repair Broken Mica Window

**G**LASS windows are now being put in automobile tops of pantasote and sometimes in the mohair tops, though the latter are really too light

in the rather unsatisfactory glass light. Scores of owners run their cars in this slipshod condition because they cannot get a proper renewal, and the part is not a vital one so it is let pass.

The harness and carriage shop is the place where a man can get service in this respect. Mica sheets are carried in stock and there are workmen who know how to unfasten the old light and sew in a new one in the most workmanlike manner. In every community there is one such place at least—they have been doing this work on carriage tops for generations—it is a real boon to the motorist to know where new

popular priced make in use, giving almost perfect satisfaction except for rear wheel trouble. The construction was the usual non-floating one having a taper axle end over which the wheel hub fitted and the drive through a  $\frac{1}{4}$  in. square key. Like all parts of this type, the keyseats were cut with  $\frac{1}{4}$  in. cutters and standard key stock was used for the keys—this of course meant that the keys were slightly loose.

A few months running gives the parts a chance to work and in this case it was the wheel hub that suffered—the keyseat would "slop over," or cut out,

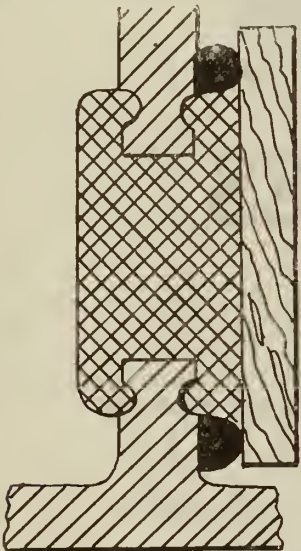

FIG. 1 - PLUGGING INACCESSIBLE HOLE IN TRANSMISSION CASE

given by the diplomatic garage owner or mechanic. Gear shifting has been the bane of many a would-be careful man; also it has been one of the chief causes of transmission expense. Practically all cars have clutch brakes which are intended to prevent clutch spinning and, in that way, aid in noiseless gear shifting. Noiseless shifting comes pretty near to being wearless shifting. An adjustment of this brake will correct all the faults that may rightly be laid to the car itself.

Some drivers resort to "double clutching." This consists of dropping in the clutch momentarily while the transmission is in neutral, and after the clutch has been disengaged previous to sliding out the gear. This evens up the clutch and engine speed so there is no pronounced clashing when the newly selected gear is engaged. This trick is valuable in changing gears on an ascent, where the change is (say) from high to second.

But in changing from a lower to a higher speed, thousands of drivers are uselessly destructive; their gear changing when starting a car may often be heard for several blocks. The trouble is invariably that of engaging gears that carry a load. "There must be a load in starting the car." I hear some one say, "unless it's going down hill." And the reason there is no clash in starting on a descent is because the transmission parts driven by the road

to support as rigid and weighty a material as glass. Most older cars and many of the modern ones of medium price have the rear light an oval of mica. When this gets cracked, or when the crack has extended and a piece chips out, the car presents a most disreputable appearance.

Makers usually refer inquirers for this part to the local garage and the garage in turn refers the customer to some glazier, who (naturally) must put

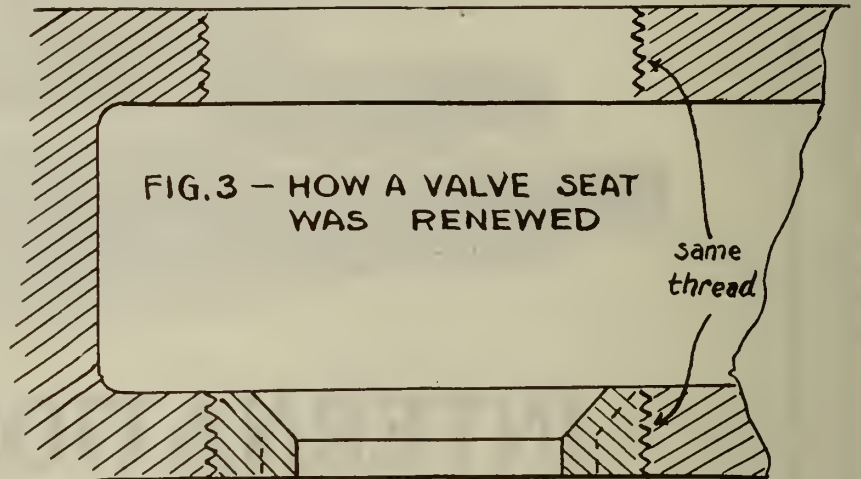

FIG. 3 - HOW A VALVE SEAT WAS RENEWED

Same thread

lights can be obtained and it is surprising that such shops do not advertise in order to get the automobile trade.

### Filling Inaccessible Hole

**T**HE car of a rather important personage had been changed from a wet to a dry plate clutch. The clutch compartment was a part of the transmission case, separated by a partition wall having a good sized hole near the bottom which permitted circulation of oil which was kept high enough for both gears and clutch to reach. The change to a dry clutch meant filling this hole, but just how to fill it was a puzzle for a time.

Finally it was decided to fill it with lead. This was done as shown in Fig. 1. About the only tool that could be worked in the bottom of the case was a long chisel; this was employed to cut a groove around the hole on each side of the wall and back from the hole about one-quarter inch. Rings of putty were laid to the outer edge of the grooves, as shown, forcing dams for the lead as poured. On one side a piece of board, suitably blocked in place, served as a form for the incoming lead while on the other side pouring was stopped when a corresponding height

and a new hub would be required. Some of these hubs we re-cut on the opposite side, making new keys that were a driving fit in both hub and axle, this helped materially, but was not wholly satisfactory because the hub castings of steel were still the softest member and cut out in spite of careful fitting.

Finally the whole trouble was eliminated as shown in the drawing by the use of double keys. The axle shaft was amply strong for this. The double keyseat in the hub gave additional surface for bearing and when keys were carefully fitted none of them ever cut out. Our procedure was first to cut the second hub keyseat, then mark the axle from this and cut to the lines.

### Cylinder Case

**O**NE of the valve seats of the cylinder of a big Mack truck had cut away as shown by the dotted lines in Fig. 3. When you took off the bonnet, you could see what was left of the seat, three inches down inside in the inner wall. The valve too was badly cut up, but this was not serious like the cylinder which looked like a case for an entire new block.

However, examination and some measurements disclosed that the largest diameter of the original seat was  $\frac{1}{16}$  in. less than the inside diameter of the bonnet threads and it was decided that a further reduction of a good sixteenth would do no great harm if we could get sufficient body of cast iron to make a tight bushing. This was successfully done as shown.

The block was put on the faceplate of the large lathe and centered by the bonnet hole. The seat wall was bored out to the same I. D. as the threads. Then the thread was "picked up" and made continuous through both walls and of the same size except a little tapering by hand of the inside thread, making it slightly smaller at the extreme end. A bushing of cast iron was made up and threaded on the outside, finally running it down through the bonnet threads, through the gas space, and screwing home in the new threads until the taper in the latter prevented further movement.

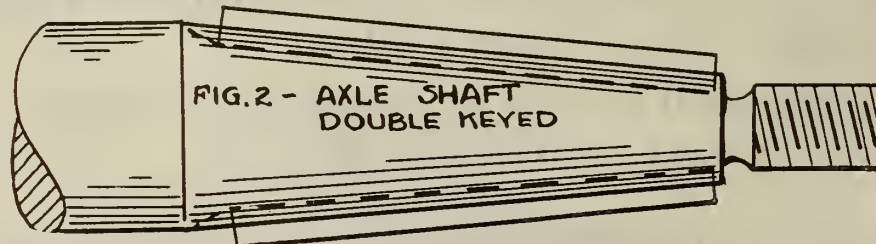

FIG. 2 - AXLE SHAFT DOUBLE KEYED

was reached. To reach the mould, the lead was run through a tube. The chisel grooves formed anchors for the soft metal and the contraction drew the metal into a tight joint. At last accounts, the job was still oil tight after a year's running.

### Wheel Hub's Service

**O**URS was a rugged country naturally somewhat hard on cars. There were a good many sedans of a



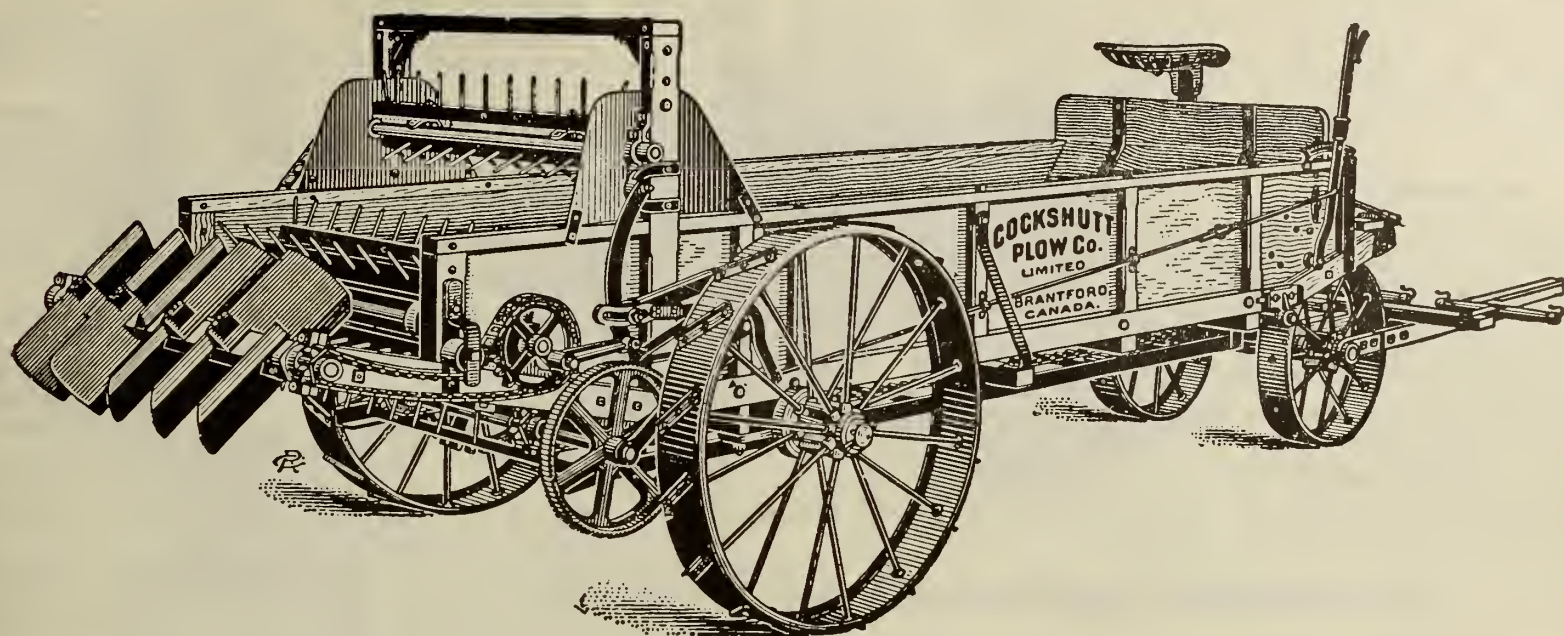

**Mr. Implement Dealer:**

**Your Prospects are Good if You Sell the**

# Cockshutt Manure Spreader

The quality and reputation of Cockshutt and Frost & Wood Implements are known everywhere. Choosing this line means you get a combination of co-operation, service and value that will certainly build up a big business for you. Cockshutt and Frost & Wood Implements are widely advertised—they're favourably known—they make their own "prospects" in every section.

The successful farmer knows the value of proper fertilizing and wants a real spreader. Be prepared to supply him with a

## Cockshutt Manure Spreader

The Cockshutt ideals—rugged simplicity, light draft, and super-efficiency—are fully worked out in this spreader. It really spreads the manure—does not merely "dump" it. It thoroughly carpets the field. Two revolving spike-studded cylinders break up the lumps, and special distributing paddles behind pulverize the manure still more, and spread it over much more than the machine's width.

There are no gears to freeze or break—a strong, direct, chain drive does the work. Specially low box for easy loading. When not spreading, machinery is not running. A handy lever does the trick. The flow of manure can be altered in a second. Feed is simple and positive no matter how big the load.

Two sizes, 50 and 65 bushels.

*Let us send you particulars of the quick-selling, business-building Cockshutt-Frost & Wood lines.*

**Cockshutt Plow Co.**

Limited

Brantford

-

Ontario

*Sold in Eastern Ontario,  
Quebec, and the Maritime  
Provinces by*

**The Frost & Wood Co.**

Limited

Montreal

Smith's Falls

St. John



By making this bushing a half inch longer than required a projecting end was left which we slotted for a half inch bar that extended up and outside the cylinder where a wrench could be used to tighten. Lastly, the excess of bushing was turned off, the seat beveled, and the casting removed from the lathe. Turning the valve finished this satisfactory job.

#### Tire Troubles

**A**MONG the minor annoyances of the automobile, tire troubles rank first. Leaky valves are the cause of many flat tires. Turning the wheel so the valve stem is up and placing a glass of water over the stem will show up any leaks here; a bubble of air escaping a minute will produce a flat tire on a car that is standing unused a week.

It is an excellent plan to make this test on the valve after the cap is screwed on. Many a puzzling slow leak has come from the gasket inside the cap getting bunched up in such a manner that it presses on the valve stem, opening it enough to let out a small but

steady stream of air. Screwing on the cap tighter only aggravates the trouble. Thus it is that when a person feels that they have everything completely sealed when they screw the cap on tightly, they may actually be doing the very thing that is causing a leak.

#### Square Scraper For Brass

**A**UTOMOBILE mechanics generally buy such tools as scrapers rather than make them as do their brothers in the machine shop. The scrapers bought are invariably of half round cross section, a shape that is not ideal for bronze and brass since the included angle of the cutting edge is so small that the scraper digs in. A better tool may be made from old square or flat files by grinding all of the teeth off and working down until sharp corners are obtained. The included angle will then be 90 degrees, much more than the half round scraper, and the tendency to dig in is greatly reduced—also this angle gives the cutting edge "negative rake," the proper condition for a yellow metal cutting tool.

donald College Farm. The following dates have been chosen: Oct. 12, 13 and 14. L. C. McQuat, of Macdonald College, has been appointed secretary in place of F. C. Nunnick, who has resigned on account of pressure of other work.

### MANITOBA

**ROLAND.**—W. Remicks has purchased the implement business of C. S. Jones.

**WINNIPEG.**—Announcement has been made of the incorporation of Winnipeg Accessories, Limited.

**BRANDON.**—An Exide Battery station, a branch of F. C. Young & Co., Winnipeg, has been opened at 236 Rosser Avenue.

**BRANDON.**—According to a commercial report, the capital stock of Manitoba Engines, Limited, has been reduced to \$100,000.

**MORDEN.**—The Overland garage, formerly operated by R. Frank, has been taken over by Frank Pegg, who will conduct a general repair business.

**ST. BONIFACE.**—A Dominion charter has been granted to the Western Wheel and Foundries Company. The company is incorporated with a capitalization of \$2,000,000.

**WINNIPEG.**—W. H. Sutton, 244 Chamber of Commerce Building, has been appointed representative in Western Canada for the Standley Skid Chain Co., Boone, Iowa, U. S. A.

**WINNIPEG.**—The Winnipeg Automobile Club will urge upon the Provincial Government the policy of jail without the option of a fine for motor car drivers found operating their cars while in an intoxicated condition.

**WINNIPEG.**—The Sterling Motor Sales, a new concern, received recently their first shipment of Beaver trucks, the latest Canadian-made truck, for which they are the agents. They also handle Sterling trucks and Highway trailers.

**WINNIPEG.**—P. A. C. McIntyre, of P. A. C. McIntyre & Co., and his assistant, K. B. Wathen, distributors of garage equipment, attended a convention recently held by the Weaver Manufacturing Company, Springfield, Ill., for their North American representatives.

**WINNIPEG.**—George E. Utke, manager of a motor school, was held up recently by auto bandits and ordered out of his car and robbed, at the point of a gun. This was the fourth holdup in one week. The affair took place on Water Street, and the thugs beat up their victim so that he had to be taken to the hospital.

**WINNIPEG.**—A course for prospective owners and drivers of automobiles has been opened in the Imperial Garage under the auspices of the Y. M. C. A. W. B. Burchall, who has had considerable experience as an instructor and mechanic, is giving the lectures. The course will cover care of cars, how to detect faults and make minor repairs.

**WINNIPEG.**—The figures of the municipal commissioner for 1919 show that only about one-third of the motors in Manitoba are owned by city residents. Of the total cars in the Province—29,313—only 9,006 were the property of Winnipeggers; Brandon claims 884, and Portage la Prairie 484. This indicates that 18,936 motor cars are operated by farmers and residents of the small towns in Manitoba.

### SASKATCHEWAN

**REGINA.**—Ryan Motors was incorporated at Regina recently.

**ATWATER.**—D. R. Williams, hardware and implement dealer, has sold out.

**SASKATOON.**—The capital stock of Canadian Motors, Saskatoon, has been increased to \$50,000.

**REGINA.**—The price of gasoline has been advanced 10 cents, and that of kerosene 3 cents in this city.

**MOOSE JAW.**—Messrs. Grant and Styles have purchased the automobile business of M. A. Hutchin.

**REGINA.**—A new concern, Halifax Motors, has been formed here.

**REGINA.**—Announcement has been made that the Imperial Oil Company will spend \$300,000 in Southern Saskatchewan this year, exclusive of extensions in Regina.

**WATSON.**—T. J. Gormican and E. E. Phillely have purchased the Joseph Vossen property on Main Street, where they will conduct an implement business. They expect shortly to have an up-to-date service garage in operation, where they will give first-class service on automobile and tractor work.

### ALBERTA

**LEDUC.**—G. G. Crossa, implement dealer, has sold to Adolph Kuhn.

**LEDUC.**—S. G. Tobin has purchased the implement and harness business of Banska & Gerogeran.

**CALGARY.**—E. J. Gifford, Western manager of the Tudhope-Anderson Co., recently paid a visit to the company's branch here.

**CALGARY.**—The Maytag Co., Winnipeg, has opened a branch here to handle Alberta and British Columbia trade. C. W. Gilson is manager.

**CALGARY.**—A new company, the Auto Top and Trimming Company, has been formed for the manufacture of auto tops, auto trimmings, seat covers, curtains, radiator covers, etc., with headquarters at 103 Twelfth Avenue East. The principals are F. W. Hoare and J. Poach.

### BRITISH COLUMBIA

**VANCOUVER.**—The Bowell - Macdonald Motor Company, Limited, have received the Provincial agency for Oldsmobile cars.

**VANCOUVER.**—The exclusive British Columbia agency for Foley tractor rims has been secured by the Giant Truck Company.

**VANCOUVER.**—The A. S. Franch Auto Company, which at present handles the new Overland "H," are now the distributors in British Columbia for the Cole car.

**VICTORIA.**—W. B. Milliken, of the Milliken-Downes Motor House, has returned from Harrison Hot Springs, where he was recuperating after a busy season last summer. The Milliken-Downes house handle the Commerce truck.

**VANCOUVER.**—Bourne & Rogers, Limited, proprietors of the Central Garage on Seymore Street, have applied to the registrar of joint stock companies for permission to change their name to that of the Corfield & Langley Motor Company, Limited.

**VANCOUVER.**—A. E. Bell, proprietor of the Ford livery at the corner of Seymore and Dunsmore Streets, has secured the Vancouver agency for the Stanley "steamer." The patrons of the Ford livery have at their disposal Hupmobiles and Fords.

**VANCOUVER.**—The officers elected for the Vancouver Motor Dealers' Association during the coming year are: President, Fred Rolston; first vice-president, J. R. Sigmores; second vice-president, M. Bowell; treasurer, R. J. Patrick; executive, Messrs. A. A. Ross, E. J. Parker and L. W. Pearson.

**VICTORIA.**—The southeast corner of Gordon and Courtney Streets has been purchased by Jameson, Rolfe & Willis, automobile dealers, for \$25,000. The firm has been operating its automobile garage headquarters on the site for several years. The property is 70 x 80 feet and occupies a space of 5,600 square feet.

**NELSON.**—The Nelson Auto Company will build a modern fireproof two-storey garage on Baker Street this spring. It will be equipped for repair work and for gasoline and oil service. A full line of accessories will be carried. At present the company is in temporary premises in the old Sunnyside Hotel building, Baker Street.

## Trade Notes

### ONTARIO

**TORONTO.**—Stephen Noxon, of the Noxon Manufacturing Company, makers of agricultural machinery, died suddenly in his rooms at the King Edward Hotel on Jan. 26 of heart failure. Mr. Noxon, whose home is in Ingersoll, was in his seventy-sixth year. He is survived by his wife and one daughter.

**TORONTO.**—Arrangements have been completed by W. J. Walker of the Lexington Motor Sales, Limited, 589-591 Yonge Street, for appointment of the Lexington Motor Sales, Limited, as contractors and distributors for airplanes and commercial and pleasure flying, for the Bishop-Barker Airplane Company, Limited.

**KINCARDINE.**—Messrs. Kenny Matheson and George Conley have purchased the implement business conducted by D. R. McPhail, which includes the Massey-Harris agency. The new firm has also purchased the vacant lot north of Baron & Co.'s store on Queen Street, upon which they will erect new warerooms this coming summer.

**HAMILTON.**—A. C. Dann, for the past nine years superintendent of the International Plow Works of Canada, has resigned to accept a position with the Oliver Chilled Plow Works, South Bend, Ind. The employees presented him with a gold watch on the eve of his departure from the city, and Mrs. Dann with a cut-glass vase filled with flowers.

**ELMIRA.**—A. Hemme, of Dublin, Ont., has bought from the town council the building formerly occupied by the Ideal Shoe Company. Mr. Hemme paid \$4,500 for the building, which includes the furnace, shafting, pulleys, pipes and belts. Mr. Hemme will use the building for the manufacture of an improved seeder, weeder and animal trap of which he is the inventor.

**OTTAWA.**—F. Frank Hayden has been appointed outside sales manager of the Dixon Motors, Limited. Mr. Hayden has had eleven years' experience in the automobile business, divided between Canada and the United States. It will be his duty as outside sales manager to appoint district agents for the different cars and trucks sold by the Dixon Motors, Limited, and to see that service is given with every sale throughout the district.

**BRANTFORD.**—It is announced that a plant will be established here for the manufacture of Bluebird electrical appliances. Local capital to the extent of \$200,000 already has been subscribed and the new company promises to employ 1,500 hands within two years. J.

B. Detweiler, general manager of the Steel Company of Canada in Brantford, will be president of the new company. The new concern will take over the local plant of Motor Trucks, Limited.

**HAMILTON.**—Frank A. Padgett, who is one of several retail auto truck dealers of Hamilton, who associated themselves together last year in an attempt to supply the demand for a wholly Canadian-built one-ton truck, reports that there is a constant demand for them. At present the company is limited to an output of six trucks a day, but with some extensions to their factory they expect to raise their output to fifteen a day by February.

**TORONTO.**—The Prest-O-Lite Company of Canada, Limited, and the Canadian National Carbon Company, Limited, have jointly purchased property at the southwest corner of Bathurst Street and Davenport Road as a site for a large new manufacturing plant. Work on the new factory will start at once. It will consist of two buildings, one of which will be 80 x 400 feet, two storeys high, with one section 80 x 80 three storeys high, to be occupied by the Canadian National Carbon Company, Limited. The second building, for the Prest-O-Lite Company, will be 80 x 400 feet and two storeys high.

### QUEBEC

**MONTREAL.**—C. M. Woodburn, of the Hamilton branch of the Dunlop Tire and Rubber Goods Company, Limited, visited Montreal recently.

**MONTREAL.**—A joint dinner of the Canada Cycle and Motor Company and the Dunlop Tire and Rubber Goods Company, Limited, salesmen and executives, was held here recently.

**MONTREAL.**—The National Motor Show of Eastern Canada was held in Montreal from January 17 to January 24, under the auspices of the Montreal Automobile Trade Association, Limited.

**MONTREAL.**—President M. J. Slack of the Montreal Automobile Association announces that the annual members' meeting of the association will be held on April 5. The business will be the election of officers and committees. Committees for the following objects will be appointed: Membership, Safety First, Sign Placing, Streets and Roads, Legislation, Publicity, etc.

**STE. ANNE DE BELLEVUE.**—Under the auspices of the Eastern Ontario and Western Quebec Plowmen's Association, the interprovincial plowing match, tractor and farm machinery demonstration will be held at the Mac-





Look for the  
EAGLE  
Our Trade Mark

Below:  
Aeroplane View  
Case 22-40 Kerosene Tractor

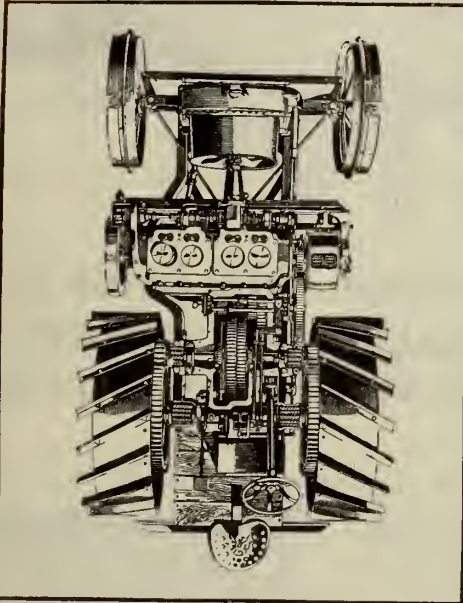

Case 22-40 Kerosene Tractor

## Here's the New Big Brother of all CASE Tractors

Conservatively rated at 22-40 h. p., with a substantial margin of excess power in reserve; a characteristic of all CASE tractors. Standardized in design along the same lines as the familiar Case 15-27 and 10-18 Kerosene Tractors, with such modifications as are necessitated by its greater dimensions and power.

The new 22-40, with all the simplicity of operation and adjustment of the smaller sizes, is offered as the ideal tractor for heavy duty, where the utmost dependability is equally essential with power.

Will drive a Case 32x54 Thresher, with windstacker, feeder and grain handler; will handle a No. 20 Case Ensilage Cutter with 40 feet of blower pipe attached; will pull four 14 in. plows in hard ground, or five plows under favorable conditions; will pull a battery of grain drills, or a pair of 8 ft. road graders, or other loads requiring similar power.

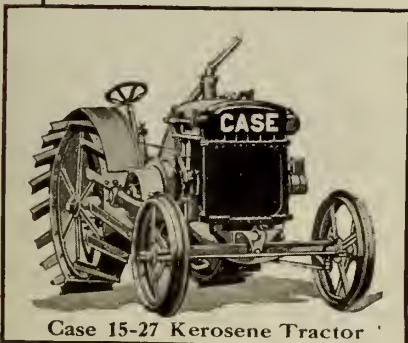

Case 15-27 Kerosene Tractor

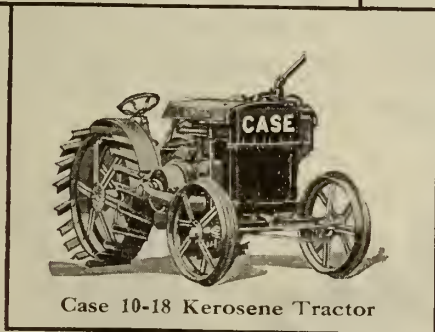

Case 10-18 Kerosene Tractor

### See the CASE Line of Tractors at the National Tractor Show

Kansas City, Mo., February 16 to 21, 1920

We invite all dealers to look over the big line at the big show. We want you to see the other lines too, and compare them with the Case.

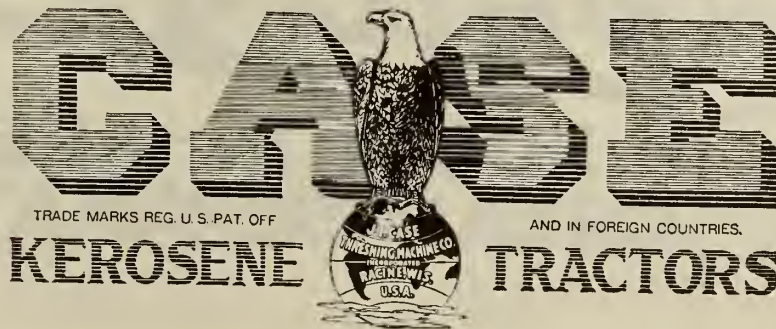

To avoid confusion, the J. I. CASE THRESHING MACHINE COMPANY desires to have it known that it is not now and never has been interested in, or in any way connected or affiliated with the J. I. Case Plow Works, or the Wallis Tractor Company, or the J. I. Case Plow Works Co.

**J. I. CASE THRESHING MACHINE COMPANY, Inc.**

Dept. O-2, Racine, Wis., U. S. A.

Making Superior Farm Machinery Since 1842

**NOTE:**

We want the public to understand that our plows and harrows are NOT the Case plows and harrows made by the J. I. Case Plow Works Co.



# The Dairy Farmer —the Man of the Hour



**AS** a producer, he is all important. His dairy products are *vital* to the health and welfare of America. The demand is large—and ever-growing.

As a purchaser, the dairy farmer is level-headed and progressive. He wants to increase his profits by using the most efficient means. He can afford the *best* because it is cheapest in the end.

The Sharples Suction-feed is the cream separator that appeals to the modern dairy farmer

The Sharples is the *only* separator that

—*skims clean at any speed* and gives cream of even destiny.

—has a knee-low supply tank and automatic “once-a-month” oiling system.

—has a single one-piece bowl. No discs to wash.

The successful dairy farmer of today can easily see the superiority of the Sharples Suction-feed. When he buys a cream separator, it is inevitably the SHARPLES dealer who secures the order.

Certain territories are open to dealers who measure up to the Sharples requirements.

# Sharples

## SUCTION-FEED CREAM SEPARATOR

THE SHARPLES SEPARATOR CO.  
West Chester, Pa.

Branches: Chicago San Francisco Toronto



Skims  
clean  
at any  
speed

The American doughboy was milk-fed. The future health and strength of this nation will depend largely on the continued use of dairy foods. The dairy farmer has a national duty in the efficient production of this food.

—P. M. SHARPLES

“There are no substitutes for dairy foods.”



**It's Your Aim—**

To Increase Sales, at an Attractive Margin of Profit, on Known, Quick-Moving Lines. That is Why You Should Carry

# “HEXALL”

Trade Mark Reg. U.S. Patent Office

## SOCKET WRENCHES



“HEXALL” Ratchet Socket Wrench No. 1--16 Pcs.

experience shows that “HEXALL” is one of the few things that they come back for and ask for by name. That's because there are no better wrenches made.

Handles are drop-forged; sockets are made from the bar on automatic machines, broached and case-hardened—every “HEXALL” is as perfect mechanically, as human skill can make it. Expert eyes

IN “HEXALL” Socket Wrenches—a set for every need—you have a highly-profitable “repeat” line, for, once you sell your trade, ex-

**“Break Any Sedgley Wrench and We Repair It---No Charge”**

watch unceasingly for flaws in material and workmanship, so that

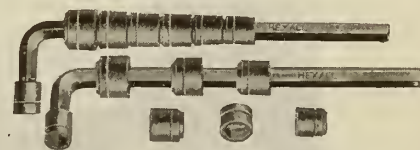

“HEXALL” Socket Wrench No. 5--8 Pcs.

when a “HEXALL” leaves the factory, the well-known Sedgley guarantee is placed upon it.

**“Break Any Sedgley Wrench and We Repair It--No Charge”**

—our bond of faith with you and a challenge to the master-workers who make “HEXALL.”

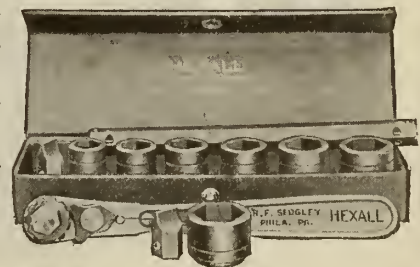

“HEXALL” Ratchet Socket Wrench No. 2--11 Pcs.

**R. F. SEDGLEY, Inc., Estab. 1897**

2311-13-15 N. 16th Street

Philadelphia, Pa.

*Also Manufacturers of “BABY” Hammerless Revolvers*

Canadian Representatives: Lamontagne, Limited, 338 Notre Dame St., Montreal, Canada



# The Renfrew Truck Scale

**D**EALERS everywhere are reaping a harvest of sales. One man sold 800 scales in seven months. We will be glad to give you his name and that of many others who order from us in carload lots and sell them easily.

This Renfrew Truck Scale is so obviously a good thing for the farmer that, often as not, he buys it on sight.

This handy Renfrew Truck Scale enables the farmer to check up on both what he buys and what he sells. It enables him to see that he gets full weight and that he loses no profits.

It weighs anything and everything from 1 pound to 2,000 pounds. Its self-adjusting platform enables it to weigh accurately on uneven ground. It weighs equally as accurately on corners as in centre of platform.

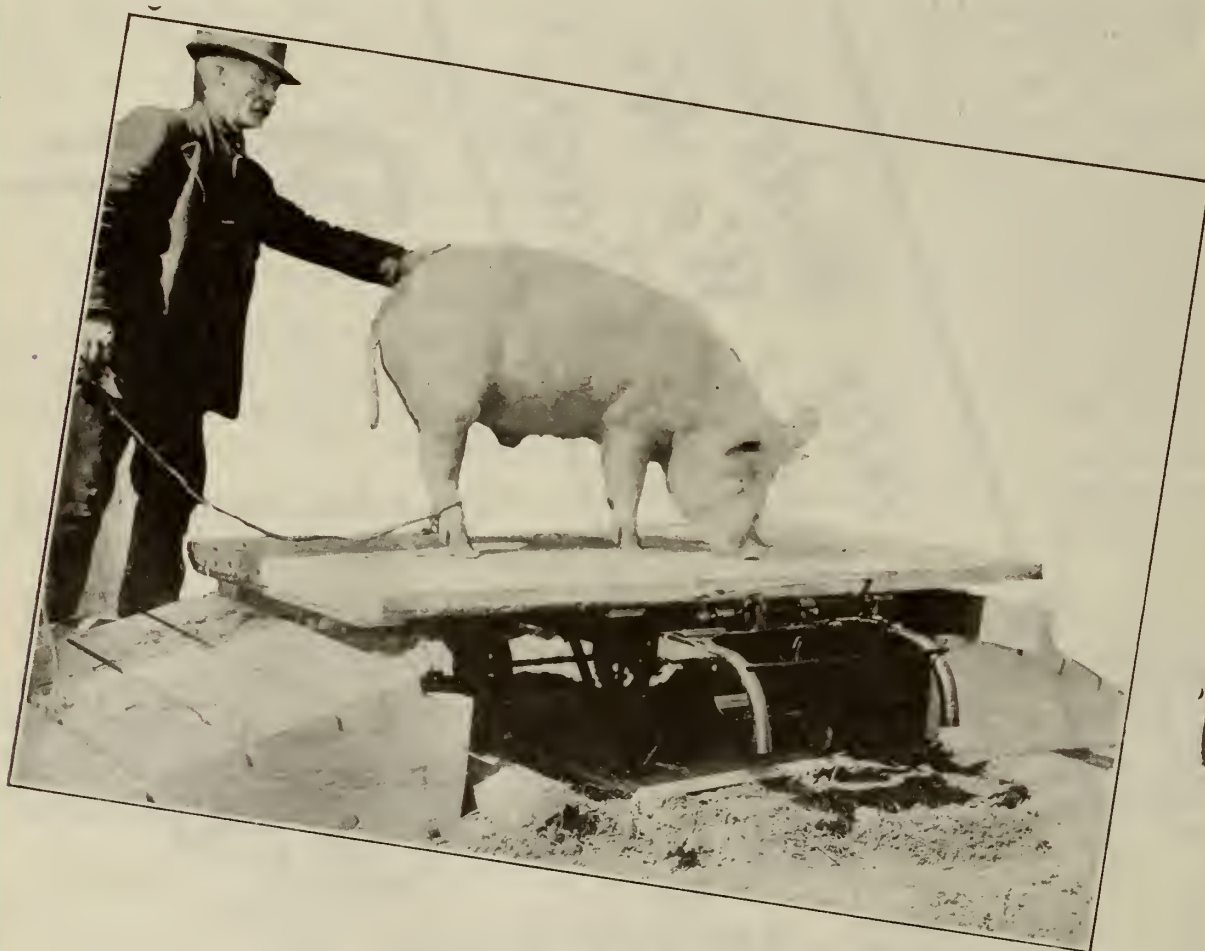

*Renfrew*

**2000-lb T**

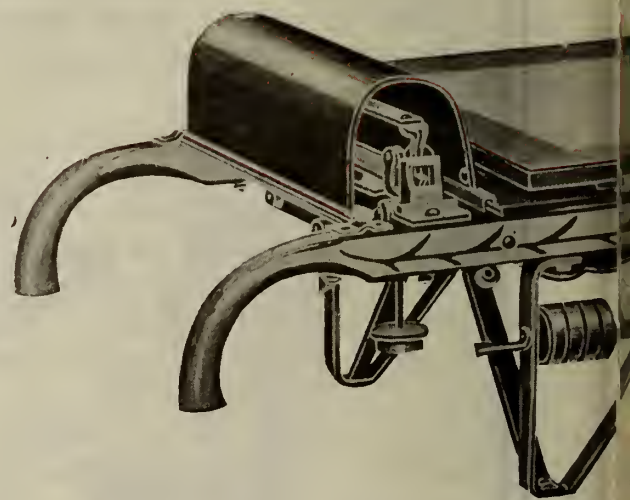

## The Renfrew Machinery Company

*Agencies Almost Everywhere in Canada*

**Other Lines: Renfrew Household Scales---Renfrew Cream S**



# Sells "Like Hot Cakes"

The farmer can place his full confidence in the accuracy of Renfrew weights. Every Renfrew Truck Scale is Government inspected and each scale carries a Government certificate of correct weight.

It is built strongly enough to carry a 2,000-lb. load yet it is not too heavy or cumbersome to wheel about like an ordinary truck.

It is simple in construction and there is nothing to get out of order.

On many farms it pays for itself in less than three months. One farmer writes, "Just this morning I saved \$20 on the sale of a few cattle and sheep."

*Every dealer in Canada should handle this live seller. Our well-equipped factory can keep you well supplied with stock for quick turnovers. We have a handsome proposition for new dealers in open territory. Write for it right away. These agencies are being snapped up quickly everywhere in Canada.*

**Renfrew**

**Truck Scale**

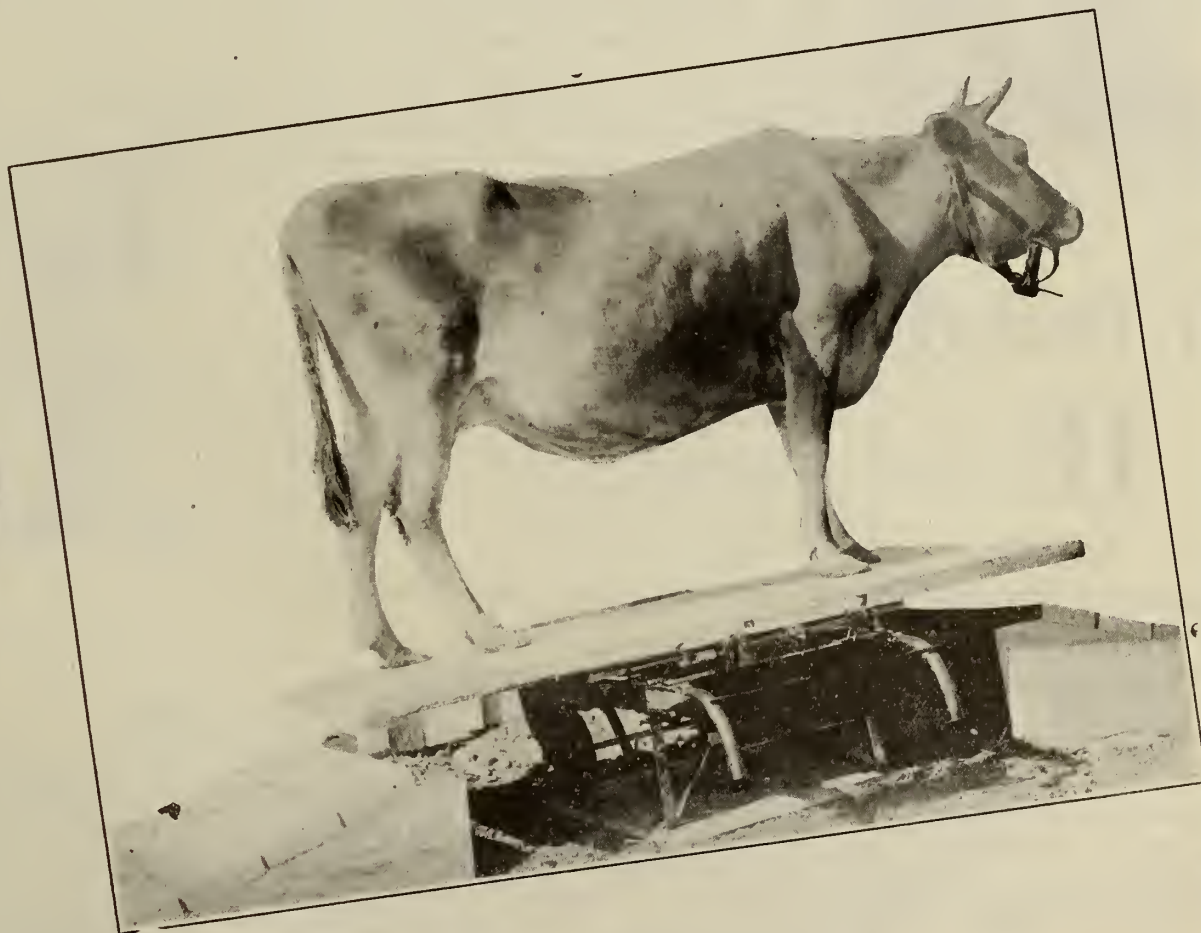

**Limited, HEAD OFFICE AND WORKS: Renfrew, Ontario**

*Eastern Branch - - - Sussex, N. B.*

**Separator---Renfrew Kerosene Engine---Happy Farmer Tractor**





We have manufactured  
**GRINDERS**  
and nothing but grinders  
for over 35 years

## "VESSOT" FEED GRINDERS

set the pace for grinding, efficiency and economy

Vessot Grinders have obtained medals and highest awards wherever exhibited, Chicago, Paris, etc.

They have become world-famous for the efficiency and durability of their grinding plates.

Write for our Agency Proposition. We pay good commissions.

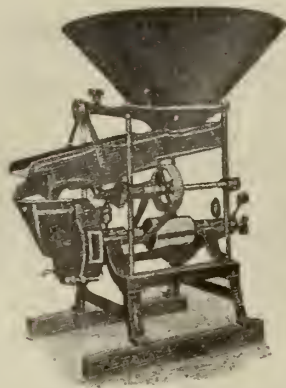

Inventors and Manufacturers

**S. Vessot & Co.**  
JOLIETTE, QUE.

Sold Exclusively in Canada By

**International Harvester  
Co. of Canada, Limited**

Branches: Calgary, Edmonton, Lethbridge, North Battleford, Regina, Saskatoon, Yorkton, Brandon, Winnipeg, London, Hamilton, Ottawa, Montreal, Quebec, St. John.

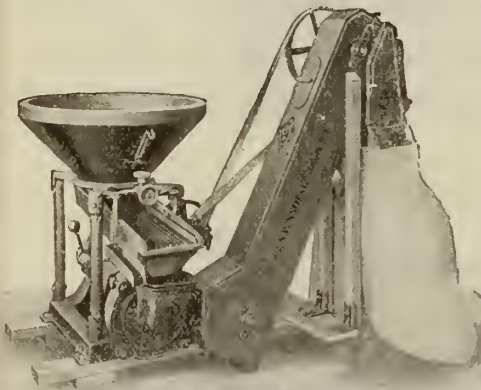

Grinder with Elevator and Bagger

# Mr. Dealer! IF

Price  
Quality of Material  
Workmanship  
Close Skimming  
and  
Easy Turning

are considered by your customers in buying a Cream Separator, then we claim that the

## Sanitary King

is the best buy in Canada to-day. Write for prices and terms.

—

## King Separator Works of Canada

Limited  
Bridgeburg or Whitby, Ont.



return to us and we will refund your money. We also make the GREB RIM TOOL.  
**THE GREB COMPANY, 319 State St., BOSTON**

SAYS THE MASTER MECHANIC: The Greb Automatic Grip Puller is a One-Man Puller—Quick-acting, strong and simple in the extreme. May be locked in any desired position. A combination of two or three arms. Heavy Duty Size capacity 1" to 1 1/2". Junior Size capacity 1" to 7". Two sets of jaws furnished with each size.

TEN DAYS' TRIAL. — If your dealer or jobber does not have them we will send you one. Try it ten days. If not satisfactory, return to us and we will refund your money. We also make the GREB RIM TOOL.  
**THE GREB COMPANY, 319 State St., BOSTON**

### MILKING MACHINE A GENUINE LABOR-SAVER

PROFESSOR F. W. Well of the California Experiment Station, after an investigation of the efficiency of milking machines, gave a lengthy report which we quote in part. He says:

"The modern milking machine is a practical and safe labor-saving device. This has been proved by the results of carefully conducted experiments, and is also borne out by the experience of practical dairy farmers in all parts of the country during the past dozen years or more.

"The investigations of this and other experiment stations have shown that milking machines, properly operated, do not injure the udder of cows, or cause garget or other udder diseases. The actual saving in the cost of milking by machine over hand milking is, however, greater in the case of large herds than with small ones and will, in general, be in proportion to the size of the herd.

"With the present scarcity of reliable, efficient milkers, and the high cost of labor, feed, and dairy supplies, the necessity of reducing the cost of milk production becomes greater than ever before. The milking machine is an important aid in reducing these expenses. We have now entered on an era of machine milking; it is the next step in the economical, efficient management of fair-sized or large dairies."

## Dairy and Household Supplies

### WHAT THE DEALER SHOULD TEACH

ONE of the most difficult problems the dealer in dairy machinery has to contend with is the education of the dairyman in the operation and proper care of milking machines and separators.

In making a sale, it is, perhaps, not a wise policy to elaborate too much on details, but once a milker or separator has been sold, the dealer should not rest until he is satisfied his machine is getting every chance, and is being properly cared for.

The production of clean, sweet milk is of as much importance to the dealer as the dairyman.

In the first place—in the case of the milking machine—the barn where the cows are being milked should be kept clean, well lighted, well ventilated and free from strong odors. After each milking the rubber tubes and teat cups of the milker should be thoroughly rinsed, and washed once daily in hot water containing a little washing powder. Special brushes should be used instead of a cloth—as it is impossible to keep a cloth in a sanitary state. A tank containing a disinfectant solution, or lime water, should be kept handy for submerging the rubber tubes and teat cups, etc., when not in use; this will keep them sweet and ensure clean milk free from putrefactive germs.

The dealer should start a campaign now among his customers to educate them in right principles. Carelessness seems to be the real trouble; carelessness in reading the instruction books and total disregard of the elements of cleanliness. Slipshod and unclean people we will always have with us, but the dealer should see to it that such people are not included among his dairy customers.

He should teach his customers to read their instruction books and follow the directions as closely as possible. If the dealer can reach this point with the dairymen he will have less trouble with milking machines going out of order, and there will be fewer complaints of bad milk, and such instances as the following would rarely occur:

A farmer came into Agincourt, Ont., one day complaining to his dealer, Delos Ressor, that his milking machine would not work. Mr. Ressor went out to the farm and when he took the machine apart found it in a fearful condition.

The rubber tubes were full of filth, swollen to twice their normal size, cracked and sucking air. The teat cups were stretched so that it was necessary to tie them on the cow with a piece of rope. When Mr. Ressor asked for an explanation he was told the machine had not been washed for eight months. This same man also had a separator which ran all summer without a drop of oil, and, like the milker, was in a filthy condition.

Of course that is an extreme case but it only goes to show the need for a persistent educational campaign. The dealer will find that a careful customer is his best advertisement.

### WATER SYSTEMS

THE live dealer, looking for a new and profitable line, should consider the water system. That there is a demand for such system goes without saying. The real need for a satisfactory water supply on the farm, and rural districts generally, becomes apparent when one considers that typhoid fever is more prevalent in the country than in cities.

By installing a water system, the farmer immediately overcomes his most troublesome problem—sewage disposal—and, simultaneously, takes an important step towards better health for his

community. The value of the farm is also considerably increased, and better insurance rates obtainable.

The prospect of having water piped to barns, dairy house, hog houses, etc., and the immense saving in labor derived thereby will make a strong appeal to the farmer.

### NEW ELECTRIC MILKER

A SMALL electric milking machine mounted on wheels so it can be moved from cow to cow has just been announced. The new Moto-Milker requires no pipe-line or installation, is ready to use when unboxed, and is so simple and handy that it is suitable for the vast number of dairies having from 8 to 20 cows.

Cups which have rubber linings fit over the cows' teats, and a gentle suction sucks the milk out. Then, intermittently, compressed air squeezes and massages the teats to keep them in perfect condition. The gentle massage by compressed air is comfortable to the cow and makes her let her milk down faster. The same milking principle in exactly similar teat cups with the compressed air squeeze is now in use on over one million cows, many of them pure-breds that have been milked in this way for six and seven years running.

The new electric milker is simple in the extreme. An electric motor drives a slow moving piston which makes suction on the back stroke and compressed air on the forward stroke. This piston



New Portable Milker.

gives the slow pulsation of suction and pressure which milks the cow so comfortably. Rubber tubes connect the pump to the milk pail and teat cups. No gas engine is necessary and most of the parts needed on pipe-line milkers are eliminated. There are no pulsators, no gauges, no tanks, no belts, no pipe lines, no stall cocks, no springs, and the high speed pump and gas engine are eliminated. Any 3/4 K. W. farm lighting plant will run the milker, the power cost being about 2c per day.

Two cows (eight teats) are milked at a time, and one man can milk about 18 to 20 per hour. Thus, one man does the work of about three.

This machine is a product of the Sharples Milker Co., West Chester, Pa., Canadian office, West Toronto, Ontario, tario.

*Mixing Her Animals.*—The 17-year-old daughter of a city man was visiting a farm for the first time.

She immediately became interested in the prize cattle and asked many questions.

One evening, just at dusk, as the girl was standing at the open door of the farm-house talking to the farmer, there came the low, mournful note of a cow.

"Just listen to that poor cow," said the girl, "mewing for her colt."



# DE LAVAL

## S i m p l i c i t y

The DE LAVAL Cream Separator is remarkably simple. Thousands of DE LAVALS are run and cleaned by children every day.

This simplicity means long life and freedom from repairs, and is the outcome of over forty years of unquestioned leadership in the manufacturing of cream separators.



Every part has been developed to its highest degree of simplicity, coupled with efficiency, and the DE LAVAL has earned for itself the reputation of "the world's standard separator."

The DE LAVAL Agency Contract is the simplest means of controlling the bulk of the separator business in any territory.

There is no better time than right now to send in an application for a De Laval contract. There is more profitable cream separator business with the De Laval than with any other separator.

### The De Laval Company, Limited

*Largest Manufacturers of Dairy  
Supplies in Canada*

Montreal, Peterboro, Winnipeg, Vancouver

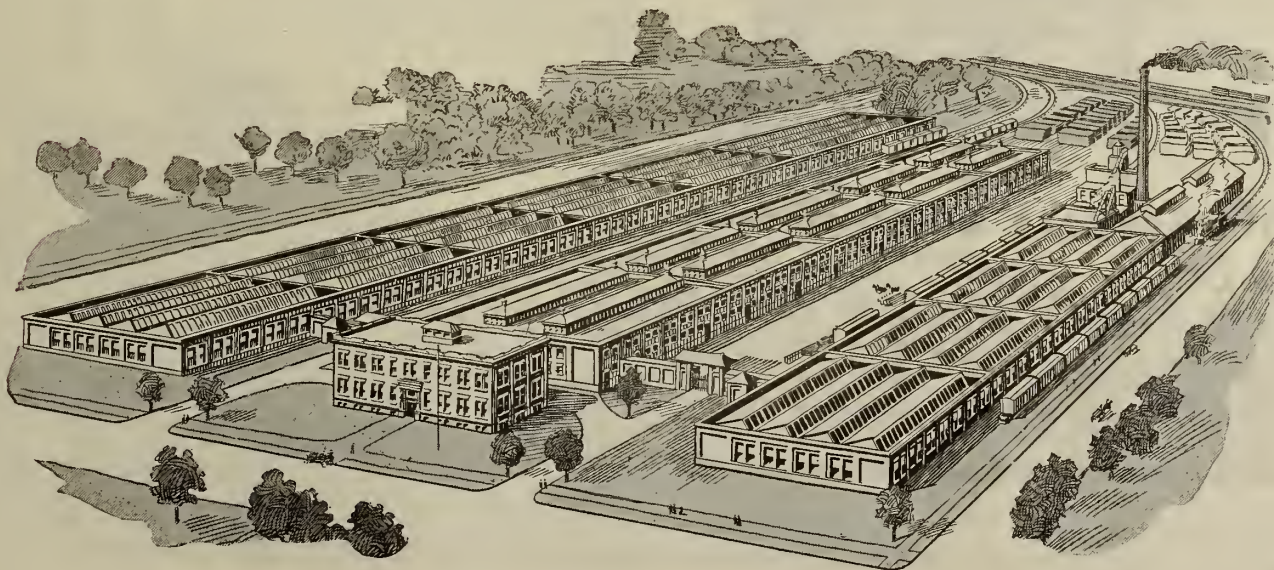



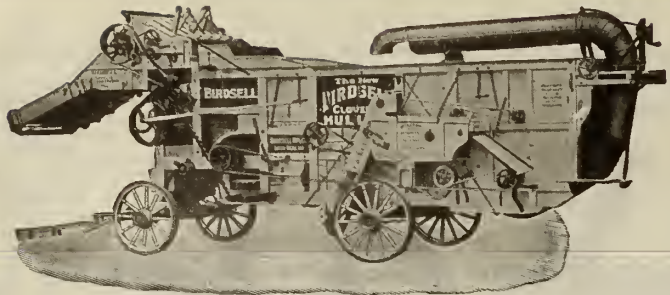

## BIRDELL CLOVER HULLERS

65 YEARS IN THE FIELD

In these days of high costs you must get **RELIABLE GOODS** for money spent or your **WASTE** will consume all of your profit.

There was never a time when "QUALITY" has been in such demand. In Quality and Honestly constructed goods lies the hope of industry today. Buy wisely and you will have economy.

**BIRDELL HULLERS** have years of experience behind them. They are not an experiment. They are built well and will last a life-time.

They hull and clean Red Clover, Mammoth Clover, Alsike and Sweet Clover seed.

BUILT IN THREE SIZES FOR CANADA

**Birdsell Manufacturing Co.** Foot of George St.  
Toronto, Canada

## Extract Wild Oats From Your Seed Grain

BRING UP THE TEST WITH A MERRYFIELD GRAIN GRADER.

Every farmer who grows grain for market should have a Merryfield Grain Grader. With this machine you can actually raise the price of the grain you market by raising its grade. With a

### MERRYFIELD Grain Grader

You can actually separate No. 1 from No. 2 wheat. You can separate wild oats from tame oats. You can separate mustard from wheat, barley, rye or oats. You can eliminate the dockage that you get at the elevator. You can make as good, if not a better separation of fowl seed from good seed than is usually made in the best equipped elevators in the country.

#### A WILD OAT EXTRACTOR.

The Merryfield Grader was built primarily for the purpose of extracting wild oats from tame oats. When this machine was perfected to a point where it would accomplish this purpose it would make every other separation desired.

## Increase Grain Growers' Profits 15 to 20%

With this machine you can increase your grain-growing profits from 15% to 20%. Your grain if cleaned and separated by this machine will command a better market, a better price, a more ready sale than is possible by not owning one of these machines.

### Cedar Rapids Foundry & Machine Co.

C. J. No. 1 Cedar Rapids, Iowa

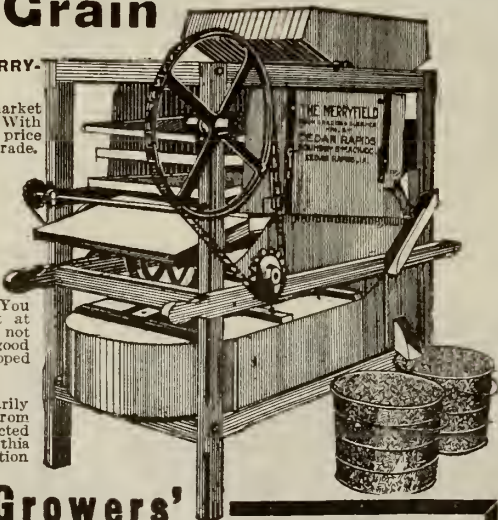

#### SOWING PURE SEED

With land values where they are today no farmer can afford to sow impure seed. If you sow mustard, wild oats or other fowl seed, you will reap just what you sow. Clean up your soil by sowing pure seed. Make farming a business. It will pay and pay big. Let us help you get more money for your grain.

Our circular "A" will tell you how. Write for it.

## NEWS — OF THE TRADE FOR THE TRADE

### ONTARIO

**LANARK.**—The Dixon Motors, of Ottawa, have opened a showroom in the Arcade Building. T. Lett Simpson is the manager and salesman.

**WALKERVILLE.**—Kales Stamping Company, Detroit, Mich., are preparing to open a Canadian factory here for the manufacture of automobile mirrors.

**KEMPTVILLE.**—Samuel Hope, of Hope Bros.' Garage, Arnprior, will open a battery-charging station and vulcanizing plant here in the spring.

**DUNDAS.**—M. and H. Jerome have started work on the erection of an up-to-date two-storey garage. The building will be 58 feet frontage with a depth of 141 feet.

**PAISLEY.**—J. B. McArthur, inventor and maker of the McArthur plow, died at his residence here on Jan. 8, after an illness of about a week, in his eighty-eighth year.

**TORONTO.**—Under direction of the Department of Highways, the annual convention of the County Road Supervisors of Ontario will be held here on March 1, 2 and 3.

**GUELPH.**—As a result of a recent trip to Britain, the vice-president of the F. E. Partridge Rubber Company, Limited, secured for the company very large export business.

**SHELBURNE.**—Robert Harrison, who has been Massey-Harris district agent in Walkerton for seven years, has moved here and will go into business on his own account.

**TORONTO.**—The Campbell Agencies, McKinnon Building, Jordan and Melinda Streets, have been appointed distributors for the Standley Skid Chain Company, Boone, Iowa.

**TORONTO.**—The new road policy of the Ontario Government, as outlined by H. F. C. Biggs, Minister of Highways, has been approved by the Dominion Good Roads Commissioner.

**NAPANEE.**—J. M. Graham has opened a new garage opposite Gibbard furniture factory. He will do repairing and painting on all makes of cars and handle tires, gasoline, oils, etc.

**BELLEVILLE.**—A. O. Roblin, of Adolphustown, has purchased the implement business of R. B. Wiseman. Mr. Roblin for a number of years was a traveling salesman of the I. H. C.

**TORONTO.**—Willys-Overland Company has purchased a lot on Don Mills road, bordering on East Queen Street, to be used as an entrance to a station which they propose to erect.

**GALT.**—Waterloo County will build a concrete road from Galt to Hespeler, and to the borders of Waterloo County, between Guelph and Hespeler, as part of the Provincial county highway system.

**SAULT STE. MARIE.**—The fire losses for 1919 totalled \$65,000, a reduction in the 1918 losses of \$150,000. Credit for this tremendous reduction in loss is given the new motor fire-fighting equipment.

**BRANTFORD.**—Messrs. Elmo Near and Stewart Wilson have purchased the automobile business known as Houlding & Walker, and will operate it in future under the name of Houlding & Walker, Limited.

**KINCARDINE.**—William Watson has purchased the store on Queen Street occupied by T. R. Reed & Son, feed merchants, and will erect thereon warerooms where he will conduct an implement business.

**GLENCOE.**—The garage and automobile business of Duncanson & McAlpine has been purchased by Messrs. Snelgrove and Faulds. They will handle all repairs, and will do special battery work and winter storing.

**TORONTO.**—A permit has been granted T. and J. Creighton for the repairing of their garage at 1244-1252 Dundas Street, which was recently damaged by fire. The cost of the repairs is placed at \$1,500.

**BROCKVILLE.**—M. B. Stack, of Lyn, has purchased from R. B. Heather the property at the corner of King and Garden streets, together with the vacant lot adjoining, and will shortly erect a two-storey fireproof garage.

**GUELPH.**—At a recent meeting of the civic fire, light and water committee, Chief John Smith of the fire department recommended the purchase of a triple combination hose and chemical car for use in the congested part of the city.

**KITCHENER.**—J. A. Martin, of Montreal, has been appointed manager of the Dominion Tire Factory. Mr. Martin, who has had seventeen years' experience in the automobile trade, is a brother of the Hon. Wm. A. Martin, Premier of the Province of Saskatchewan.

**TORONTO.**—R. B. Morley, general manager of the Ontario Safety League, advocates stricter enforcement of the present laws in regard to regulation of traffic on streets and highways, and urges the reduction of the speed limit to the old figure of fifteen miles per hour.

**TORONTO.**—The partnership between Thomas B. Haley and Joseph Bruder in the "Canada Garage," situated at 466 Bathurst Street, has been dissolved by mutual consent. The business hereafter will be carried on by Thomas B. Haley, who will receive and pay all claims.

**WELLAND.**—The incorporation is announced of the Marvel Company, Limited, of Welland. The new concern will manufacture automobiles and accessories, including the steering device for Ford cars known as the "Marvel," and also deal in electricity, motor power, heat and light.

**TORONTO.**—At the annual Ford Company banquet, held recently in the King Edward Hotel, about 300 Ford dealers from the Toronto, London and Windsor branch districts were present and had an enjoyable time. G. M. McGregor, general manager of the Ford Company of Canada, presided.

**ST. THOMAS.**—W. H. Thibeaudau and W. H. Kettle have purchased the garage and auto business of James D. Black and will continue the business under the name of the St. Thomas Motor Sales Company. The garage will be thoroughly renovated, and the firm has contracted to handle McLaughlin cars exclusively.

**MERRITTON.**—General Forgings and Stampings, Limited, is the new name of the Canada Pole and Shaft Company, Limited. It has been deemed advisable to change the name owing to the fact that the business has changed from that of a pole and shaft business to that of an automobile forging and stamping business.

**LINDSAY.**—The plant of the Dominion Wheel Company, which has been closed down for three years, has been re-equipped with machinery for the manufacture of truck wheels, passenger car wheels, and some special repair work on passenger car and truck wheels, and will be operated by the Hayes Wheel Company of Canada.

**WINDSOR.**—The first annual show of the border automobile manufacturers will be held in the Windsor Armories March 2 to 6. The show was originally planned as an exclusive exhibition for Canadian manufacturers, but it is now thrown open to the United States. Robert Jaffray, manager of the exhibition, says floor space is at a premium.

TO SUBSCRIBE FOR THIS PAPER JUST SIGN THE COUPON, PUT \$1.00 WITH IT AND MAIL IT IN CANADIAN MOTOR, TRACTOR AND IMPLEMENT TRADE JOURNAL, Toronto, Ontario.

I have pinned \$1.00 to this coupon. Please send me CANADIAN MOTOR, TRACTOR AND IMPLEMENT TRADE JOURNAL.

Name .....

Address .....



# “We Handle the OilPull *because*

—it burns kerosene successfully,  
—it delivers its rated horsepower,  
—it stands up for years at hard work.”

—*Thronsen & Lindahl.*



“WHEN we were considering a few years ago what tractor we should sell,” said Thronsen & Lindahl of Canby, Minn., “we wanted one that would burn kerosene successfully, that would deliver the power claimed for it and would stand up for years at hard work. While looking up the record of various machines we found three 30-60’s and one 15-30 OilPull that had been doing hard work for about nine years. They are all on the job yet and will be for years to come. They all burn kerosene now as well as they did when new, and have plenty of power.

“Second, the OilPull is well known and well advertised. The Rumely organization is well founded and will not blow up over night.

“They have large branch houses that give good service and the factory guarantee is a winner. The advertising and sales help given the dealer is something unusual and the territory reserved for each dealer is large enough to justify an investment.

“But, after all, the main reason for wanting the Rumely OilPull agency is our honest desire to sell a machine that we know is good.”

The Advance-Rumely line for 1920 includes four sizes of OilPull Tractors—12-20, 16-30, 20-40 and 30-60 H. P., and five sizes of Ideal Separators—22 x 36, 28 x 44, 28 x 48, 32 x 52 and 36 x 60, all standard in design and construction.

We have a dealer proposition that offers unlimited possibilities. Ask for it.

## ADVANCE-RUMELY THRESHER COMPANY, Inc.

Calgary, Alta. La Porte, Indiana Regina, Sask.  
Saskatoon, Sask. Winnipeg, Man.  
48 Abell Street, Toronto, Ont.



Seven reasons why Thronsen & Lindahl find tractor business profitable.

# ADVANCE-RUMELY



# Automotive Accessories and Implement Equipment



## TACO TRACTOR GOVERNOR

A new TRACTOR governor with many features is being manufactured by the Tractor Appliance Co., New Holstein, Wis. The makers say that friction in the throttle valve of the Taco Governor is eliminated by mounting same on ball bearings. The valve is properly balanced, so that there is no tendency to close when released. By means of the unique arrangement, the speed of the engine can be changed during the load range by means of a regular speed control.

The entire mechanism is enclosed in a dust-proof housing of neat appearance, the governor shaft, upon which the balls are mounted, runs in ball bearings, and the end thrust due to the control spring, is taken up by the end thrust ball bearings. The governor weights are heavy enough, insuring a good pull or torque on the throttle valve.

The installation of the governor is simple, and can be done by one man in less than an hour's time. No tools other than those furnished with the tractor are required, as there are no holes to drill and no other mechanical operations to perform. It fits right in and forms a part of the machine. The makers guarantee the governor to maintain a speed within 10%.

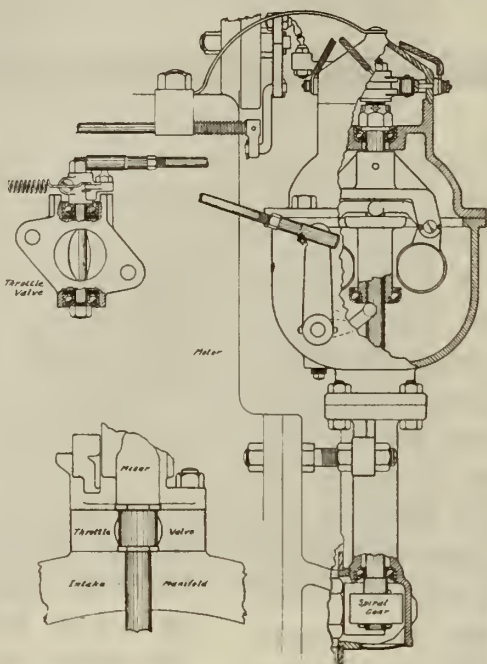

Sectional View Taco Tractor Governor.



Gilmer Woven Endless Fan Belts.

designed carburetor choke lever. A carefully prepared instruction book accompanies the outfit giving complete details for installation.

## GILMER FAN BELT

WOVEN from tough long-fibre cotton yarn specially spun, the Gilmer endless fan belts, manufactured by the L. H. Gilmer Co., Philadelphia, are made to cover practically the entire range of flat type fan belt demand. The makers say they are neither spliced nor laced, like most ordinary belts and they do not slip or jerk but run evenly and smoothly, driving the fan quietly and with minimum wear. Each belt is treated with a special non-evaporating compound developed by chemists; by this process every thread is thoroughly impregnated, making the belt unaffected by heat, moisture, dust or mineral oils. These belts are distributed in Canada by the Canadian Fairbanks-Morse, Canadian General Electric and several other prominent distributors.

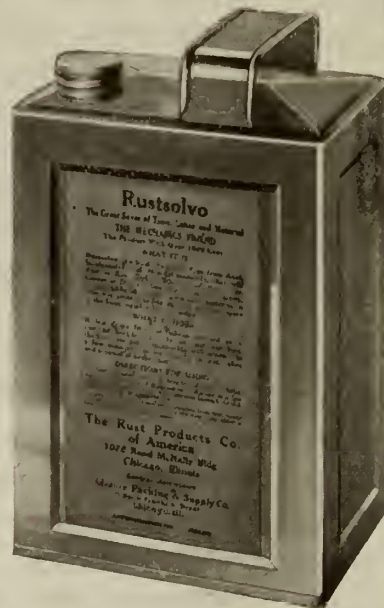

Rustsolvo.

## GEMCO OVERLAND "4" BUMPER

THE Gemco Manufacturing Co., Milwaukee, Wis., has brought out a new bumper to fit the rear of Overland "4" cars. One of the most important features, the makers say, is the fact that the bumper fits on the frame of the car without loosening any bolts, or damaging the machine in any way. Each bracket is attached by means of a forged hook; the lugs on the brackets being staggered to fit on each side of the channel of the frame. These lugs hold the bumper from sagging when attached. The bumper is finished in the highest grade of black enamel or nickel plated.

## RUSTSOLVO

THE Rust Products Company, 1026 Rand McNally Building, Chicago, Ill., have put on the market a product for removing rust or carbon, known as Rustsolvo. It is a free flowing fluid, non-inflammable, a few drops of which—the makers say—will cut any deposit of rust, carbon, graphite, or green corrosion, enabling bolts, nuts, pins, etc., which have become rusted in, to be easily loosened and removed.

## TREX RIM COMPRESSOR

THE Trex Rim Compressor is designed for removing and replacing automobile rims of the split type. It is adjustable to any size rim, and holds it in collapsed position, while the tire is taken off. When the tire is replaced, it forces the rim back into place. The makers say it does not injure rim, or spring it out of shape; and there is no danger of pinching the inner tube.

In replacing the tire, the flat end of the compressor is placed against the inside of the rim. The other end of the tool is hooked over the opposite side of the rim and when the ratchets are reversed the handle is worked back and forth until the rim goes back into place. The device also locks the rim. It is made of malleable iron and works like an ordinary jack. It is distributed in Canada by the Trexler Company, 397 Guy Street, Montreal.

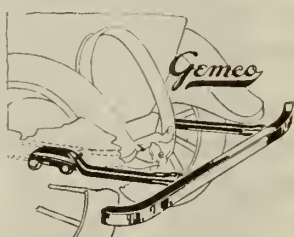

Gemco Overland "4" Rear Bumper.

## STARTING AND LIGHTING SYSTEM

THE Atwater Kent ignition system is the six-volt, single-wire type, designed for the new style 1919 Ford. It is furnished complete, say the makers from the tail lamp and bulb, to the smallest washer required for installation. It is manufactured by the Atwater Kent Mfg. Co., 4937 Stenton Avenue, Germantown, Philadelphia, who say it is easy to install and requires little attention. The generator is the compound wound type, which automatically adjusts itself to the load, and delivers to the battery its proper charge under all conditions.

The starting motor is equipped with a standard Bendix Drive, and is of the series wound type with large brushes and commutator. The system is fitted with an exide, 80 amp. storage battery, and the instrument board is complete with switch, ammeter, and a specially

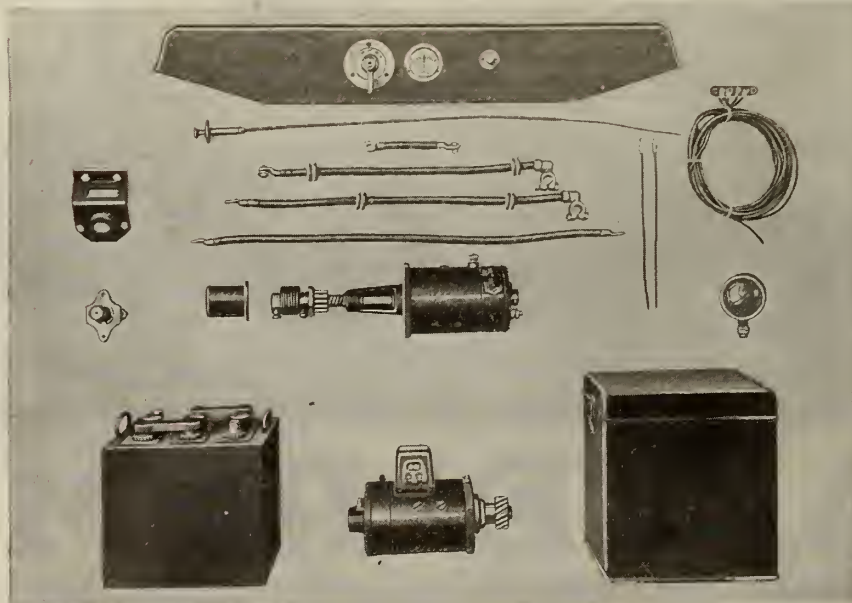

Atwater Kent Starting and Lighting System.

## STEEL SPRING AND TIRE

A TIRE has been invented, which, it is said, will revolutionize the tire industry. The inventor is an Akron rubber worker, Guy Stever, who has received his patent papers. In place of an air cushion, Stever has substituted flexible steel springs. The casing is also of flexible steel in lieu of rubber. Stever was working on his invention for five years, during which time he guarded his secret very closely. No working model has been made yet. The only rubber used in Stever's tire is in the cord tread. For 30 x 3 inch tires, Ford size, a 3-16 inch steel spring forms the cushion. The tread is supported by a flexible steel band with the spring beneath. The tire is built onto steel rims and ready for adjustment.



# SATISFACTION

## Dealers, Garagemen, Customer

"CHAPMAN" bearings are husky-strong bearings filled with long hardened steel rollers that will stand the load, better than balls, actually too small for the job.

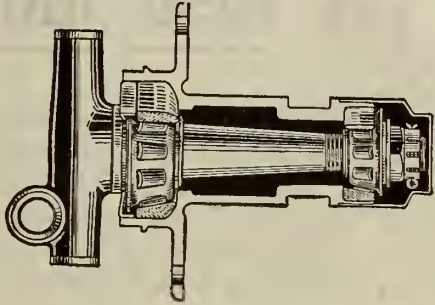

They will outlive the machine in which they are fixed and are only a small investment.

They pay for themselves over and over again during the first season.

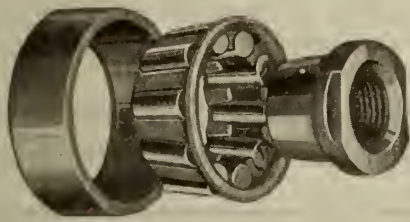

These bearings are Made in Canada and they are carried by jobbers everywhere.

## ADD TO YOUR PROFITS AND GOODWILL

Dealers need them because they are what the customer wants. They make good profits for the Garage man, and since they give the best service to everybody concerned, they spell satisfaction all round and satisfaction means increased profits.

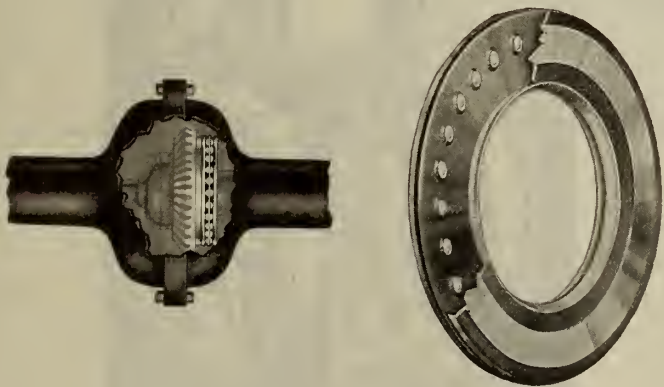

*Write to Us for Full Particulars*

**The Chapman Double Ball Bearing  
Co., of Canada, Limited**

347 Sorauren Ave.

Toronto

# ALLIS- CHALMERS TRACTORS

The 6-12 Tractor is readily attached to any implement the farmer may already have, requiring four horses or less and forms a real one-man outfit. 12 Belt Horse Power.

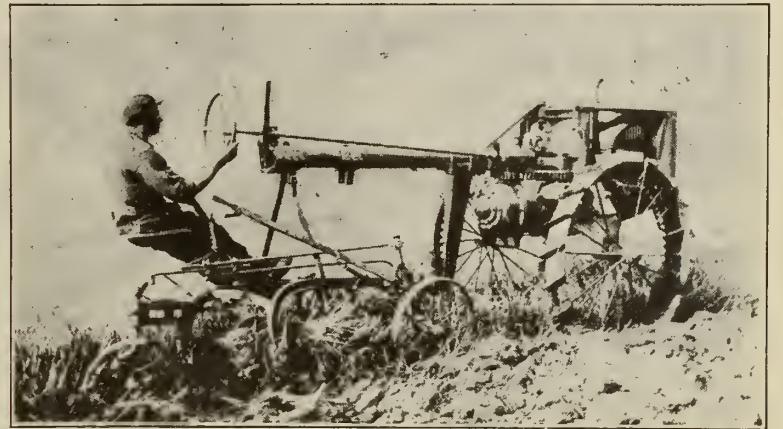

## DEALERS:

Territory being rapidly taken.  
The Sales Proposition is right.

**APPLY NOW**

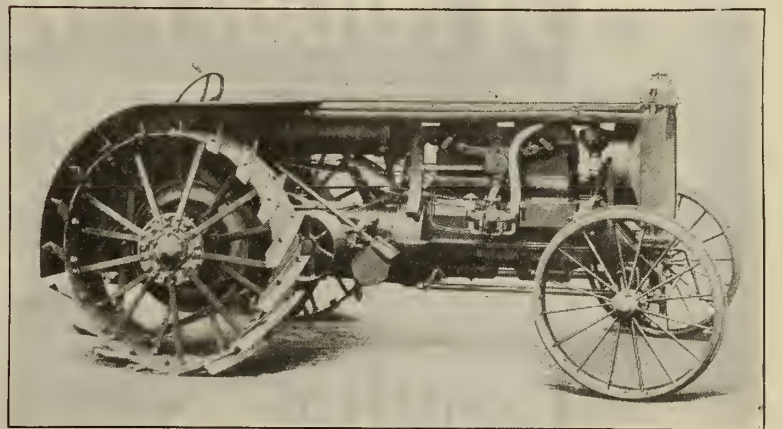

The 18-30 Tractor embodies the most modern engineering and construction. Officially proven a leader in the Tractor Field.

**CANADIAN  
ALLIS-CHALMERS, LIMITED**

Head Office, 212 King West

**TORONTO**



# The Ford Steering Control Sells Easily and Quickly:

## A Real Money Maker

With this steering appliance you can absolutely derive the same pleasure and safety in driving a Ford, as you experience in the highest priced cars

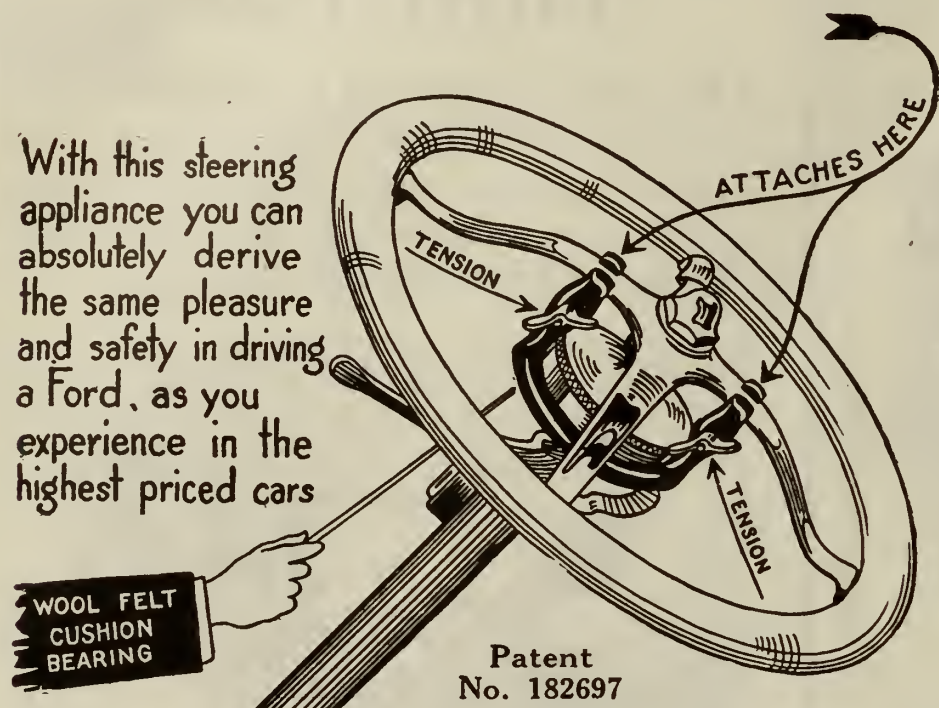

Patent  
No. 182697

Every Ford owner needs this device. A short demonstration clinches the sale. Sold on a "Drive it for TEN DAYS and if dissatisfied get your money back" guarantee. You can easily sell 9 out of 10 owners in your locality. The price \$3.75 (retail) is right.

Relieves all the strain of gripping the wheel. Saves tires by eliminating the quiver of front wheels. Minimizes the danger of swerving on rough roads. Guides the car in a straight line. Practically does away with cold hands in winter caused by gripping the wheel tightly.

Drop us a line for agency proposition and full particulars of terms and prices.

### Rothwells Auto Specialties

Successors  
to

McKenzie, Crews & Company  
Richmond Bldg. Toronto, Ontario

## A MIGHTY HELPING HAND

### Guaranteed? You Bet!

Any part found defective during the life of the engine is replaced by us, free, but we don't have to make good on that guarantee very often.

Dealers! You want to handle an engine you can tack your personal guarantee onto.

Go as far as you like in recommending the

## London Engine

She's a smooth-running, regular performer—lots of power and no fuss or trouble. Vertical type, same as high-grade auto engines. No trouble from dirt in cylinder—no tank—no fan—no leaky joints—no freezing in zero cold. Gasoline is contained in the base—means safety and lower insurance rates.

This engine will win you FRIENDS. It's "The Right Arm of Power"—a grand piece of work you'll admit when you see it.

We are advertising the "LONDON" Engine from Coast to Coast.

Write for terms and territory

LONDON GAS POWER CO., Ltd.,

29 York Street, LONDON, Canada.

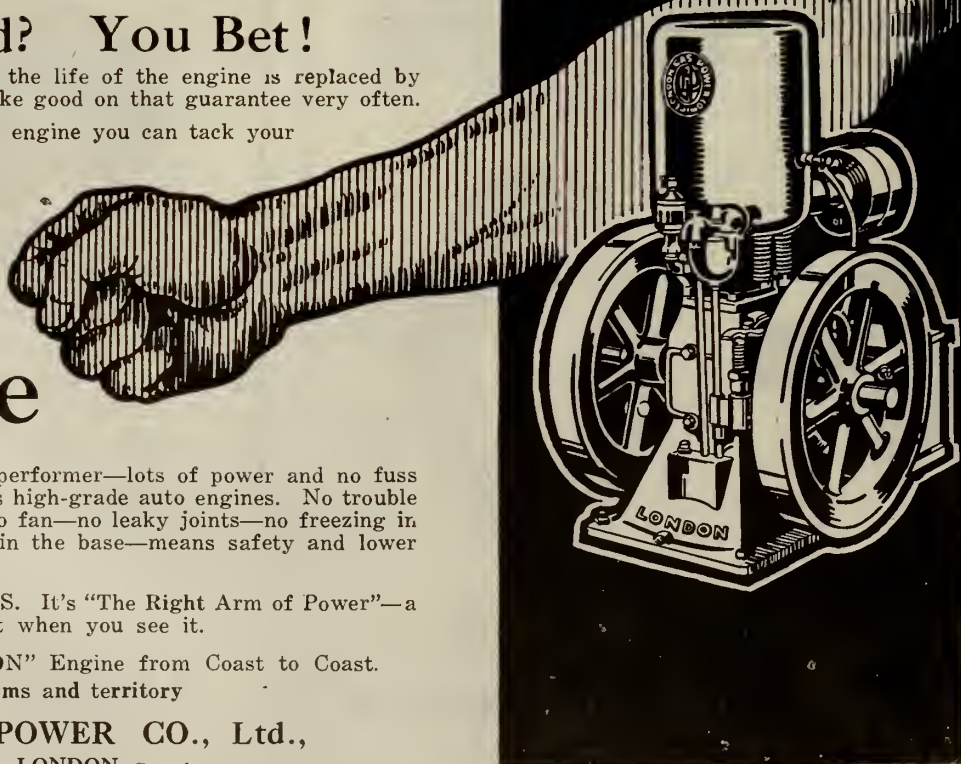



# Power Plants Make Farms More Livable

By FRANK SCOTT

**E**XPERTS who have analyzed the rapidly increasing demand for electric light plants on the farms estimate that within the next five years more than 60 per cent. of the farms of the country will be so equipped. It is simply another illustration of the increasing ability of the farmer to take advantage of all labor-saving and comfort-giving devices.

A few years ago such an innovation as electricity on a farm was the greatest rarity except in those districts where the power could be obtained with short transmission. But the high prices paid in recent years for farm produce have so increased the farmers' buying powers that the purchase of an electric lighting plant becomes entirely possible.

It is a big field for the dealer in implements and automobiles and one that has rarely been touched. Unlike the tractor, which has to be demonstrated widely before its advantages become manifest to the average farmer, electric lighting is a thing with which the farmer is thoroughly familiar: He knows its advantages; he sees them when he attends a motion picture theatre, when he switches on the lights of his car, when he rides in a trolley car. It is something with which he has been familiar all his life.

And its advantages to him are obvious. The farmer is coming to realize more and more that mechanical power will give him better results than the old-fashioned, back-breaking methods. He has witnessed it time and again in the tractor, in the automobile—in dozens of other devices he had adopted.

The installation of electricity provides advantages quite as great. With electricity, the wife's tasks of washing, ironing, churning, running sewing machines, will be lightened in some cases as to become almost negligible. And the comfort and appearance of a house lighted by electricity compared with the old-fashioned, smelly, often dangerous oil lamp are patent. Electricity, too, will bring what the farmer usually regards as luxuries in his home. At his disposal will be electric toasters, chafing dishes, heating pads and other domestic conveniences.

**T**HAT is in the house. Outside, the advantages of an electrical plant are quite as great. One of the chief of these lies in the elimination of the danger connected with the use of an oil lantern. Many a fine barn has been reduced to ashes through a lantern being kicked over.

The rays of a lantern are feeble, too. In a large barn or stable they penetrate only a very few feet. Electricity, however, will illuminate the largest farm building by means of a very few bulbs. And good lighting is both economical and labor-saving. On the average farm in winter time a great deal of the work is done during the hours of darkness, in the early morning and in the evening. Horses are harnessed, unharnessed, fed and their stalls cleaned; milking is done. It is easy to see how much the farmer would gain through being able to do this work in a well-lighted structure.

The simplicity of the modern electric light plant is another strong argument in its favor. The unit system, by which generator, storage battery and switch are mounted on the same base, is especially easy to handle.

The best way to form an accurate idea of the demand for electric lighting plants is to make a trip through the country and remark the number of houses without them. It will convince the dealer of the splendid prospects for such a line.

The logical dealer or distributor for farm lighting plants is the car or implement dealer, for the reason that, if operating in a town of any considerable size, he has a sales force and advanced selling methods—a considerable advantage; but whether a dealer on a large or small scale he usually has a financial and business standing in the community that should give him an advantage over competitors.

In the case of the auto dealer, it is further apparent that he would be particularly suitable for such work, because he usually has a car; and it would be easy for him to attach a cabinet in which could be carried the lighting plant and take it out to the house of the man who wants a demonstration.

**F**OR the dealer operating on a big scale, there is no doubt that the sale of such devices should be established on a system independent of the other activities of the agency. But in the case of the small dealer such sales could be undertaken in conjunction with other work quite profitably.

Regarding methods, the best the average dealer could adopt would be to go right out and work the territory, while at the same time distributing the advertising literature—if of a convincing nature—of the company whose product the dealer is placing.

The great trouble with the trade in this commodity in the past has been the inclination of the dealer to treat it as a side line of secondary importance, to be worked at only when there was an off season in autos, tractors or farm implements. This is a mistaken idea. It is not a matter to which casual reference should be made only spasmodically, but one which, if success is to be attained, should be given as much attention as any of the above-mentioned articles.

The one great objection in the way of selling plants lies in the fact that the average farmer is firmly convinced that electric lighting is a luxury to be enjoyed by town folk; that the lighting of farm houses by electricity is a far cry. But it should be easy to disabuse his mind of that idea, because the farmer is thoroughly conversant with electricity. He realizes its advantages—it requires little demonstration. And that is a point to keep well in mind: the farmer knows the values of such equipment just as well as he knows the advantages of farming with motive power. The only thing required is to convince him that he is in a position to enjoy those advantages, that he can afford them just as well as the inhabitants of the towns.

## NO MOTOR SHOW FOR TORONTO

**T**HE annual meeting of the Automotive Industries Association of Canada was held at the National Club on Jan. 26. The two most important matters under discussion were motor exhibitions and the purchase of trucks and cars by the Government without tenders. It was decided at the meeting that no motor show would be held in Toronto this winter, owing to the fact that no suitable building was available. It was further decided that a deputation from the association wait on the Government asking that all public automobile equipment be purchased hereafter by tender.

Among those present were: R. Gray of Gray-Dort Motors, T. Russell of Willys-Overland, Ltd., S. McLaughlin, McLaughlin, Oshawa, and T. McGregor of Ford Car Co. G. M. McGregor was elected President and R. S. McLaughlin of Oshawa, Vice-President.

## THE BEST BUMPERS OBTAINABLE



"KABEE"  
SPRING ARM CHANNEL  
BUMPER

"LYON"  
RESILIENT BAR  
BUMPER

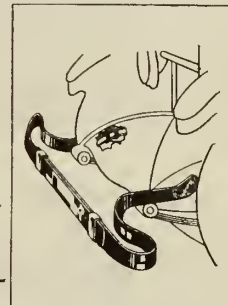

DURABLE BRILLIANT FINISH  
PATENTED "HOOKBOLT" ATTACHMENT  
FITS 90% OF STANDARD CARS  
OBTAINABLE FROM JOBBERS & DEALERS  
CATALOGUE ON REQUEST

**KINZINGER BRUCE & CO. LTD.**  
NIAGARA-FALLS, CANADA  
SOLE MANUFACTURERS, UNDER  
LYON CANADIAN PATENTS.

## Hindview<sup>®</sup> AUTO MIRRORS



Style A

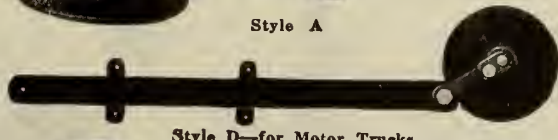

Style D—for Motor Trucks



C Bracket  
for Closed Bodies



Style A—Long



Style F  
for Front Fenders

The "Hindview" Auto Mirror prevents accidents by enabling the driver to keep an eye on the rear traffic without losing sight of the road ahead. Our Ball Joint allows immediate adjustment to any desired angle without the use of any tool.

Substantially made—nicely finished—has five inch plain, or lens, plate glass mirror. The lens mirror increases the field of vision about 50 per cent. without distorting the view. Note large, firm clamp for attaching to windshield.

Write for our folder showing complete line Agents, Jobbers, Write for our Proposition.



Superior Quality

Prompt Deliveries

## PRESSED METAL PARTS, LIGHT AND MEDIUM WEIGHT STAMPINGS

Our complete plant, superior equipment and efficient organization are at your service. You will insure satisfactory results by letting us make your stampings. Motor, axle, transmission and clutch stampings. Write to-day enclosing blue prints or samples for estimates and our catalog.

## KALES STAMPING COMPANY

446 West Lafayette Blvd.

Detroit, Michigan

Canadian Representative: Donald F. Johnston, 146 Bleury St., Montreal, Que.; Yonge and Dundonald Sts., Toronto, Ont.; 612 Portage Ave., Winnipeg, Man.



## RADIATOR GUARD

THIS new motor truck accessory consists of a section of Irving Subway grating, mounted in a strong steel frame shaped to conform with the radiator. Irving Subway, is a form of grating; its exclusive and distinctive feature is its truss-like arrangement of alternate straight and reticulate steel bars, solidly riveted up and taking a blow or pressure edge-on.

The makers say that in tests Irving Subway has proved to be one of the lightest and strongest forms of grating made. The full advantage of this great shock-resisting material is embodied in the Safety Radiator Guard. The opening through the grating is 80 per cent. of the panel area, so that ample air circulation is assured. The device is made in a variety of styles and sizes adapted for all standard makes of trucks. It is manufactured by the Irving Iron Works Co., Long Island City, N.Y.

## RIE NIE FABRIC FAN BELT

THE Durkee-Atwood Co., Minneapolis, Minn., have placed on the market a new type of fan belt for automobiles and trucks, known as the Rie Nie fabric fan belt. The makers say a special feature of the belt is a wrapper, or jacket, which encloses the filler plies, preventing fraying, and leaving no raw edges to absorb oil or the possible clogging of the fan belt bearing. This belt has been tested on all makes of cars and proved satisfactory.

## BURD PISTON RING

THE new Burd piston ring is of the step-joint type; the outer surface, which comes in contact with the cylinder wall, having raised edges which, the makers say, wear down quickly, seating perfectly with a glass-like surface in harmony with the cylinder wall, in about 45 minutes. A channel, .002 of an inch in depth, is in the centre of the face, and carries an oil film, that prevents cylinder wear during the seating process.

The Burd quick seating piston ring is made in all sizes, for practically every make of motor. The makers say the material used is of the highest quality, dense, tough gray iron, filtered so that all impurities are removed. The rings are ground to micrometric accuracy of .00025 of an inch, are exceptionally resilient, and will not break down under cylinder heat conditions. They are made by the Burd High Compression Ring Co., Rockford, Ill., Auto Sales, Ltd., 545 Yonge St. Toronto.

## STOW TWO-SPINDLE DRILL

THIS machine is a two-speed, two-spindle portable electric drill, designed for doing exacting work. The makers say, by means of the two spindle drills, from 1-16 to 3/4-inch can easily be used, and drilling efficiency and accuracy assured. It is fitted with a heavy-duty type of motor, extra heavy bearings and grease-encased gears made of specially treated steel.

No. 1, or centre, spindle is fitted with Jacobs chucks, taking S.S. drills 0 to 1/2-inch, speed 450 revolutions per minute. No. 2, or the offset, spindle, is fitted with a Morse taper socket and takes Morse taper drills up to 1 inch, speed 225 r.p.m. This tool is specially adapted for use in a small shop or garage where not more than one tool of this kind is desired. It can be supplied for either alternating or direct current, and is manufactured by Stow Manufacturing Company, Binghamton, N. Y., U. S. A.

## JEFFERY'S MARINE GLUE

THIS is a powerful glue for waterproofing boat decks, hulls, covering canvas, ammonia pipes, etc. The makers say its peculiar properties are those of flexibility and durability, and although it becomes soft and pliant under heat, it still retains its strong adhesive properties, and is clean and insoluble

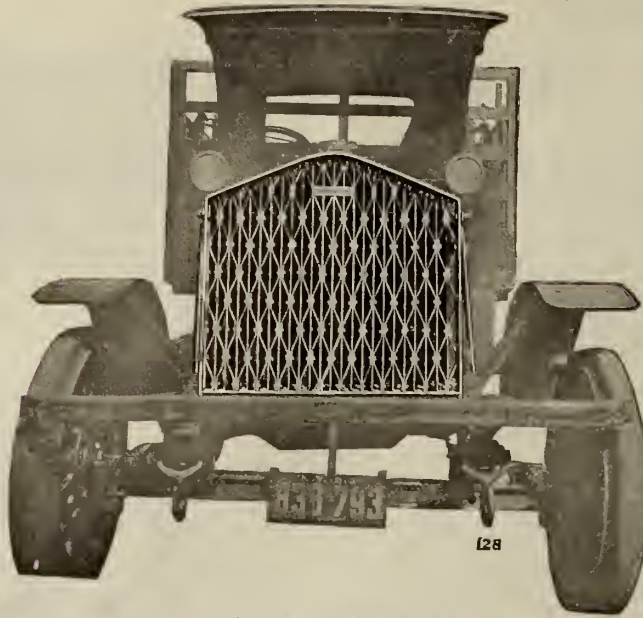

Irving Safety Radiator Guard.

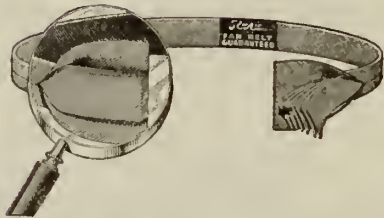

Rie Nie Fan Belt.

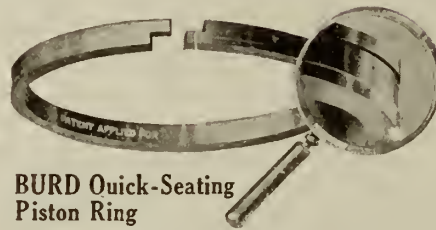

BURD Quick-Seating Piston Ring

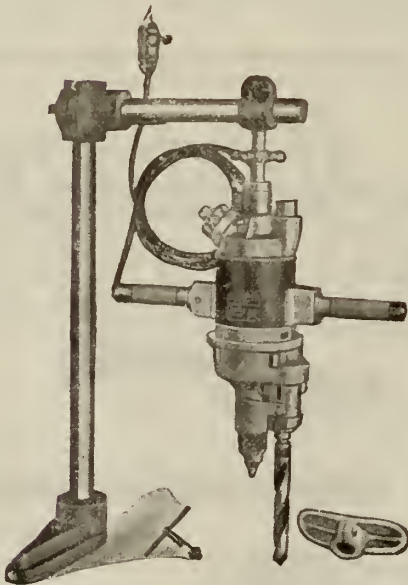

Stow Two-Spindle Drill.

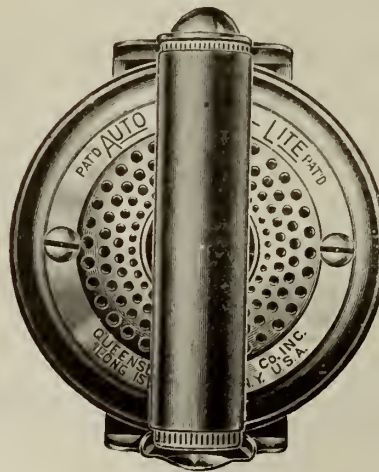

Auto Spark Lite



Vulcan Tool Holder

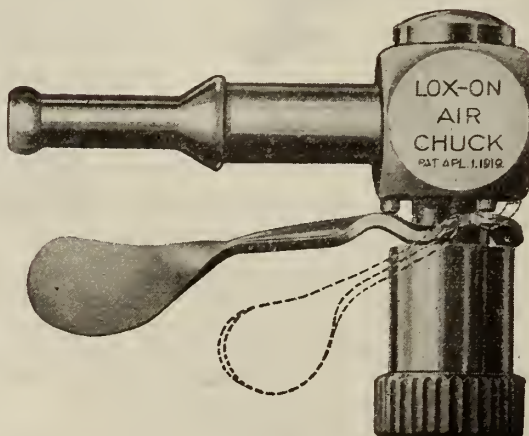

Lox-on Air Chuck

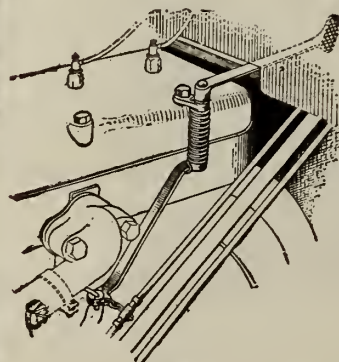

Accelerator

in water. It is manufactured by L. W. Ferdinand & Co., 152 Kneeland Street, Boston, Mass.

## AUTO SPARK CIGAR LIGHTER

A DEVICE of special convenience to motorists who smoke, known as the Auto Spark Lite, is being marketed by the J. C. McAdams Sales Company, 51 East 42nd Street, New York. The makers say it will operate on any make of car or motor boat using gasoline as fuel. In operation it is simplicity itself, insuring a reliable light, as it operates by simply igniting a gasoline-soaked wick from a spark taken from any one of the spark plug circuits of the motor.

The Auto Spark Lite is attached to cowl board and connected to a spark plug. It is made of metal, black enameled, with nickel-plated centrepiece; contact points are enclosed in porcelain body. The Canadian distributors include John Millen & Son, Ltd., Montreal; Hyslop Bros., Toronto; and Bowman Bros., Ltd., Saskatoon.

## FORGED-CUTTER TOOL HOLDERS

THE Vulcan forged cutter tool holders are manufactured by J. H. Williams & Co., Brooklyn, N.Y. The makers say the holders are all drop-forged from a fine grade of special steel, so heat-treated as to develop its maximum toughness and stiffness. They are simple in construction, being composed of but three parts—the holder proper, a square-head cam, and a locking pin.

The cutters are also drop-forged from "Agrippa" high-speed steel, and are finished and hardened ready for use. They are furnished in a wide range of sizes and types—diamond-point, roughing, hog-nose, flat-nose, threading, etc. The angular seat on the rear of the shoulder permits the locking pin to force the heel, or step, of the shoulder directly against the holder proper. The Canadian distributors are the A. G. Low Co., Saskatchewan, Sask.

## FOOT ACCELERATOR

ADAMSON foot accelerator, which is manufactured by Adamson Manufacturing Company, Hamilton, Ont., is specially designed for use on Ford cars. The manufacturers claim that this new device can easily be attached in a few minutes by Ford owners, and that it is only necessary to remove one of the cylinder head screws to clamp the accelerator in position, a wrench being the only tool required.

Another feature claimed for this accelerator is that, owing to the simple construction, no fitting or altering is necessary, thus making it an easy matter for almost anyone to install.

The attachment cannot rattle, and consists of only one moving part supported by a spring tension bearing as shown, and is a practical device, giving the operator complete control of the throttle with the foot. It is operated entirely independent of the hand throttle, similar to that regularly used on all other cars, and is of equal convenience.

## LOX-ON AIR CHUCK

THIS is a device of special use in the garage and air station. It is made by the Automatic Safety Tire Valve Corporation, 1765 Broadway, New York, who say the Lox-On Air Chuck cuts down electric bills, lengthens the life of the compressor and stops the expense of replacing rubber washers every day. It slips over the valve and then grips it, or releases it by turning the lever.

The air chuck is guaranteed not to leak. It is provided with a metal baffle-plate which prevents the chuck from being pushed down over the valve shoulder. All parts are accessible and interchangeable.

The device is made with a universal stem to fit either 1/4-inch or 3/8-inch hose. When the lever is turned on, the rubber is pressed in, gripping the valve tightly and preventing any escape of air.



# Sales are Quick

---the Profit **GOOD**

## “Casco” Coil Box Protector

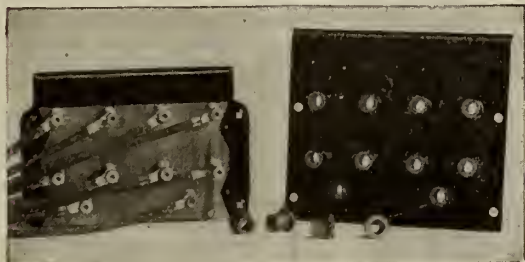

*The Only Protector for FORD CARS  
Against Rain and Wet Weather*

Ford cars frequently stall in wet weather. The water works in between the hood—into the coil box, causing short circuit.

This inconvenience is prevented if you use the “Casco” Box Protector. It covers the Ignition and Coil Box.

Dryness is guaranteed.

Without Rubber ..... \$1.00  
Rubber Insulated ..... 1.50

## “Casco” Oil Drain Cock



Pat Oct. 7, 1919

The “Casco” Oil Drain Cock is Automatic in action. No cock wrench is required.

No Ford owner should be without one, as it enables him to easily keep close tab on the oil level and prevent unnecessary wear of bearings.

Complete, per pair, \$1.50

## “Casco” Fan Belt Guide



There are many good prospects in your vicinity for these

# Ford Necessities

They aren't accessories in the ordinary sense of the word—they're necessities. Show them to a Ford owner and he wants them immediately. He *needs* them, and when he sees the price is right they go like hot cakes.

“Let Ford Owners Know You Sell Them  
—the rest is easy”

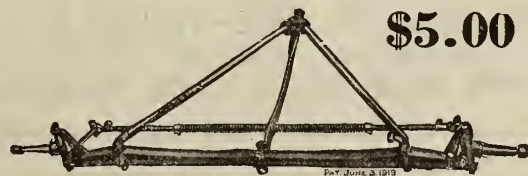

\$5.00

“Hold 'Em in the Road” for Ford Cars

## Hold 'Em in the Road

Radius Rod Brace, Anti-Rattler, Axle Support and Safety Device All in One. There is no Accessory Manufactured for Ford Cars that carries as Strong Combination of Strength and Safety. FITS ALL MODEL FORDS TO 1919 INCLUSIVE.

**Cooper Auto Supply Co., Thomasville, Ga., U. S. A.**

A. H. Frazier, 1150 Homer St., Vancouver, B.C.

Manufacturers' Agent

CANADIAN JOBBERS

Merrick-Anderson Co., Limited, Winnipeg  
John Millen & Son, Limited, Montreal, Toronto



Made in Canada



No. 500  
1/2" Standard with  
Three-in-One Terminal



No. 501  
3/8" Standard with  
Three-in-One Terminal



No. 502  
3/8" Long with  
Three-in-One Terminal



No. 503  
3/8" Long with  
Chevrolet Ball Terminal



No. 506  
1/2" Long with  
Three-in-One Terminal

## Hotter Spark for All Cars

M. & S. Spark Plug No. 500 is Standard Equipment on Model No. 4 Overland

M. & S. three-in-one terminal is adapted to any style ignition wiring. For the Chevrolet there is a special model ball terminal.

Hotter Spark! You can feel the quicker response the moment you start your car—if you have the M. & S. hotter spark!

The M. & S. ball point, concentrating the current, and thus intensifying the heat, means a larger and hotter spark.

You can feel your car answer to the better ignition and more complete combustion. It's great! Alone this hotter spark justifies a trial of M. & S. Plugs.

The high grade porcelain has perfect chemical glaze unaffected

Dealers! Order from your nearest Jobber or write us direct for descriptive circular

**M & S**  
The Plug with the Hotter SPARK

by heat. High heat test ensures against spark troubles. And mark this—

M. & S. porcelain is interchangeable. One Porcelain fits all plugs.

One - piece Centre Elec-

trode of 97% nickel-steel eliminates the danger of carbon fouling.

M. & S. Plugs are Canadian made by Canadian workmen. Nothing but very highest class materials and workmanship.

Our hard and fast guarantee means just what it says—complete satisfaction or free repair or replacement.



No. 504  
Regular with  
Three-in-One  
Terminal  
and Gaskets



No. 505  
Porcelain  
with Chevrolet  
Ball Terminal  
and Gaskets

**Machine & Stamping Co., Limited**

Commercial Dept.—Russell Motor Car Company, Limited,  
1209 King Street West, Toronto, Ontario

## Costs Little—But

THOUGH you protect your home—your barn—your stock with insurance against fire does not free you from the loss following damage to many valuable documents and papers that maybe you now keep in an ordinary locked drawer.

The extra protection against fire, loss or theft outweighs the slight cost of installing a "Taylor" 199—It just fits the Farm Home.

Dealers and supply houses write for terms.

**J. & J. Taylor**  
LIMITED  
Toronto Safe Works  
TORONTO



## Manager Wanted, for Canadian National Newspapers and Periodicals Association

To act also as Secretary-Treasurer, and carry on the Association's general work, under the direction of the President and the Board of Directors, study the interests of the various classes of publications in the Association, and plan and carry on promotion work in their interests. Applicants should understand advertising and merchandising.

Apply in writing only, stating age, full details of experience, and salary expected. Applications will be treated as confidential.

Address Acton Burrows, President, Canadian National Newspapers & Periodicals Association, 70 Bond Street, Toronto.

## ENGLISH MOTOR AMALGAMATION

LONDON, ENGLAND.—What the biggest motor amalgamation in England hopes to achieve in the way of mass production was set forth at a recent luncheon at the Savoy Hotel. The new organization will be known as Harper, Bean, Ltd., H. J. Whitcomb, chairman of its board, stated. Associated with it are such firms as Hadfield's, Ltd., Harper, Sons & Bean, Ltd., the Vulcan Engineering Company, Ltd., Swift, Ltd., the British Motor Trading Corporation, Ltd., the Harvey-Frost Company and the Birmingham Aluminium Company. It represents £6,000,000 in capital.

Mr. Whitcomb rejected the description of combine for the organization, explaining that that was the point against which, in this amalgamation, the whole energies, intentions and principles of the directorate would be firmly concentrated.

"It is estimated that not less than two years must elapse," said he, "before our ideal magnitude of production can be achieved and we can enter upon our projected programme of units for 100,000 motor vehicles. Thus we shall start with a completion of only fifty cars per week in January and increase this number gradually until we expect to complete by July, 1920, 300 per week; by December, 1920, 600 per week; by July, 1923, 2,000 per week.

"Our programme does not include the high priced vehicles, but the car for the multitude—50,000 of one type (the small car), 25,000 of the medium car and 25,000 of the commercial vehicle—three types only.

"Provision has been made to give our employees a real and tangible interest in the results in the form of 500,000 fully paid ordinary shares, to be held by trustees on behalf of the employees as a whole for the purpose of a benevolent fund for them and their dependents."

## ONTARIO MOTOR LEAGUE BANQUET

THE annual banquet of the Ontario Motor League was held in the King Edward Hotel on Jan. 19, when upwards of 700 members were present. The President, J. J. Gibbons, presided, and in his remarks announced that representatives of 80 distinct affiliated organizations were in the room. The principal speaker was the Hon. F. C. Biggs, who spoke at some length on the new road policy of the U. F. O.

The officers elected for the ensuing year were: President, G. A. Hodgson; First Vice-President, A. R. Green; Second Vice-President, W. F. Goforth; Third Vice-President, J. B. McKillop, President of the London Motor Club, London, Ont. Ald. F. M. Johnston, Brig.-Gen. H. C. Bickford and Brig.-Gen. John A. Gunn were added to the Board of Directors.

## DEALERS ENTERTAINED

THE management of the J. I. Case Co., Saskatoon, entertained their local dealers recently to a banquet at the Hub Cafe. The gathering was held in connection with their annual school for dealers and farmers handling their implements. W. L. McQuarrie, the organizer for Northern Saskatchewan for the Retail Merchants' Association, attended and gave an address on the work that was being done by the Saskatchewan-Alberta Branches of the Association, from their Provincial office at Saskatoon.

VANCOUVER. — The Rand Tire Company has secured a lease on a property at the corner of Granville and Drake Streets, and work is already under way on an up-to-date garage with a frontage of 50 feet on Granville and 120 feet on Drake Street. The company expects to occupy the new premises in February.



THE COMMERCIAL CREDIT COMPANY OF CANADA LIMITED

IS

A CANADIAN COMPANY offering service of interest to and in the interest of Canadians.

Time payments made possible and profitable for Manufacturer, Dealer and Customer. Of particular interest to Automobile and Musical Instrument Trades.

LET US KNOW YOUR REQUIREMENTS

THE COMMERCIAL CREDIT COMPANY OF CANADA LIMITED

Bank of Hamilton Building, Toronto, Ontario  
McArthur Building, Winnipeg, Man.

WE GIVE

**“Quality and Service”**

IN

TRACTOR and TRUCK  
STEEL CASTINGS

**JOLIETTE STEEL CO., LIMITED**

903 Read Building, Montreal  
JOLIETTE, P.Q.



**EXCLUSIVE FEATURES AT  
SEED-BED PREPARATION**

No other tractor is so well adapted to this work as the GRAY. The Wide Drive Drum and wide front wheels distribute the weight so that no wheel marks or ruts are left in the seed-bed. The side hitch permits the easy hitching of all tillage tools,—discs, packers, harrows and cultivators.

You can also plow and do belt work. It is truly a general purpose tractor.

It also has a reputation for quality and a low repair record. It has proved itself over a long period of years. It is here to stay.

Dealers—we have territories open.

Write for full information

**THE GRAY TRACTOR CO. OF CANADA, LIMITED**

307-9 Electric Railway Chambers  
WINNIPEG, MAN.

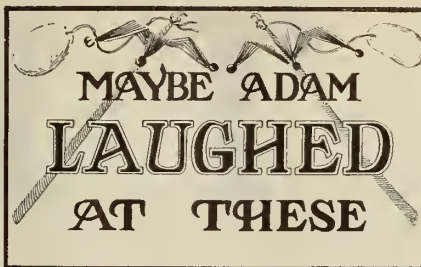

*A Real Job.*—A financier is one who can keep up both the auto and the mortgage that got it.—Greenville (S.C.) Piedmont.

\* \* \*

*What Was He Starting?*—Mr. Ed. Grosch had the misfortune of having a bone in his right arm broken while he was attempting to start it one morning last week.—Mendotta Reporter.

\* \* \*

*Raising the Rent.*—“If you can supply me with two rooms I’ll give you fifty dollars a week.”

“You’re too late; a gentleman’s promised to marry me for them two rooms.”

\* \* \*

*Right on the job.*—“What’s that big crowd up at Smith’s place?”

“Well, they are salesmen that the old man sort of promised he’d buy a new tractor from some time durin’ the year. Twenty-six landed this afternoon, and the road is full of them on their way.”

\* \* \*

*A Little Early.*—The kind old gentleman met his friend, little Willie, one very hot day.

“Hello, Willie!” he exclaimed. “And how is your dear old grandpa standing the heat?”

“Aint heard yet,” said William. “He’s only been dead a week.”

\* \* \*

*Nothing on Him.*—“You know,” said the lady whose motor-car had run down a man, “you must have been walking very carelessly. I am a very careful driver. I have been driving a car for seven years.”

“Lady, you’ve got nothing on me. I’ve been walking for fifty-four years.”

\* \* \*

*Out of Countenance.*—A Wichita woman, while reading football reports one day recently, chanced to inquire of her husband if he ever played football at college.

“Yes,” he replied. “I played one game and they just simply walked all over my face.”

“Oh,” she rejoined, “so that is what happened to it then!”—Wichita Eagle.

\* \* \*

*Made a Difference.*—Collector to small boy. “Is your father home?”

Small Boy: “Lemme see if I can remember. If you’re the man that sold Pa the threshing machine, he has gone to town and don’t know when he will be back. But if you are the man that owes him for threshing your crop, he is right around there in the woodshed.”—Minneapolis S. & M. Co. Bulletin.

\* \* \*

*Too Good to Be True.*—Anxious Inquirer: “Is it true that for five dollars I can insure my house for \$3,000?”

Clerk: “Quite true, madam. If your house burns down we pay you \$3,000.”

“And do you make any inquiries as to how the fire originated?”

“Certainly. We make the most careful inquiries.”

“Ah! I thought there was a catch in it somewhere!”

\* \* \*

*Horn Was O. K.*—Possibly the apex of sarcasm or something was reached the other day when Jones took his fliiver to a repair shop and asked the man there what was the best thing to do with it.

The repair-man looked the car over in silence for several minutes, after which he grasped the horn and tooted it. “You’ve a good horn there,” he remarked, quietly. “Suppose you jack it up and run a new car under it!”—Boston Transcript.



**NO  
Fumes**



Sell the Time Saver Engine Drive Washer with a good engine and a BT Line Shaft. The Operator does not get the gasoline fumes, as she does when the engine is attached to the washer.



**Time Saver  
Engine Drive Washer**

The small engines attached to some washers are a troublesome proposition. The engine runs under variable conditions. Women don’t understand it. It means numerous trips on your part to make explanations and repairs.

Larger engine with a line shaft, will run the washer better. It will give you less trouble. It will run other machinery as well. Send to our nearest branch for catalogue.

**Beatty Bros., Limited**

St. John, N.B. Fergus, Ont. Winnipeg, Man.  
Montreal, Que. London, Ont.  
Edmonton, Alta. Vancouver, B.C.  
London, Eng. 16 Holborn Viaduct, E.C.1.





# VETERAN

## MOTOR TRUCKS

*Made in Canada*

### POWER, LOW UPKEEP, LONG LIFE

This combination interests the man who has freight to haul

#### Why We Use The Buda Model H.T.U. Engine

**Because** it is essentially a real Truck engine, weighs 800 lbs., heavy duty type,  $4\frac{1}{4}$ " bore,  $5\frac{1}{2}$ " stroke.

**Because** it develops its maximum horse power, 33.1, at the low speed of 1100 R.P.M.

**Because** it has full forced feed lubrication, even to the wrist pins.

**Because** of the greatly increased cooling area for cylinder walls.

**Because** it has detachable cylinder head, thus top overhauls can be made without taking down the engine.

**Because** the water circulating passages are so arranged as to produce the greatest efficiency with proper cooling around the valves and a uniform temperature of the entire combustion chamber.

**Because** of its oversize crank shaft bearings. Front bearing,  $2\frac{1}{8}$ " x  $3\frac{1}{8}$ "; Middle,  $2\frac{1}{4}$ " x  $2\frac{3}{4}$ "; Rear,  $2\frac{3}{8}$ " x 4".

**Because** of the extra wide face,  $1\frac{1}{2}$  inches of the timing gears, and their accessibility.

**Finally, Because** we consider that it is the best.

#### Why We Use the Cotta Transmission

**Because** the gears are always in mesh, and there is no gear shifting, the reductions being made by means of dog clutches, the gears remaining in mesh, careless drivers cannot rack or strip the gears.

**Because** we get four speeds forward, the extra cost entailed being more than compensated for by the diminished wear and tear to working parts.

**Because** the four speeds permit a wider range of intermediate speeds and give to the wheels a greater amount of power when in low gear. Therefore, when in low gear the load can be got under way with a minimum strain on all parts.

**Finally, Because** we do not know of a better.



2-2½ Ton Model complete with Cab and Stake Body

## Eastern Canada Motor Truck Co., Limited

HULL, QUE.



# Possibilities of the Motor Truck

*A Review of Its Present Uses and Possible Developments.*

**W**HAT the motor truck is doing for us in our everyday life and what it is likely to do in the future is the subject of an article in *Colliers'* by Joseph Brinker.

In the everyday work of the motor truck, he says, some uses stand out prominently—for instance, the chain-store idea as applied to groceries, meats, cigars, shoes, clothing, and many other products. In fact the motor truck has really been responsible for the success of the chain-store idea. It was cheaper and quicker than railroad, express, or horse-drawn vehicle. One large wholesale grocery concern, with warehouses in Jersey City, N.J., increased its chain stores from 712 in 1914, when it first used the motor truck, to 3,900 in 1919; fully 60 per cent. of the goods was forwarded by motor truck and 40 per cent. by freight, express, or horse wagon. The 108 motor trucks employed by the concern mentioned are operated in ten cities and handle nearly 200,000 tons of groceries a year.

**S**EVERAL years ago meat packers maintained that it was impossible to distribute fresh meat between one city and another, or in the outlying territory of a large city, by means of motor trucks. While refrigerator trucks won the confidence of the packers in the beginning, it is a fact that fresh meat wrapped in burlap and covered with tarpaulin is now being carried in open truck bodies without spoiling, even in summer weather. One truck owned by a Detroit packer now makes a daily round trip between that city and Toledo, a distance of over fifty miles. By the use of a trailer, it carries 9 tons of meat and makes the trip one way in six hours. Previously by rail it took two and one-half days. The truck service rendered has been so satisfactory that the packer is now contemplating extending it to branches in Flint, Lansing, and Pontiac, Mich., and to other cities within a 100-mile radius.

**W**HENEVER you think of the high cost of shoes, remember that shoes are shipped from the factories to the retail dealers in wooden boxes and that the cost of these boxes must be included in the selling price of the shoes. One progressive shoemaker in Brockton, Mass., is not held up by embargoes. He transfers the lumber used for making the shoe cases in 9-ton lots daily by means of a 5-ton truck pulling a 4-ton trailer.

Nearly everything that we eat, wear, and use is now handled one or more times by motor trucks on its journey from the point of origin to the final consumer. Milk, for example, is generally hauled in cans from the farm to the railroad in horse wagons or motor trucks. This is expensive, and in certain sections the dairies are now employing 500-gallon tanks mounted on motor trucks. This bulk handling is so economical that it gives promise of eventually becoming the general practice.

Upon reaching its rail destination in the city, the milk is again handled by motor trucks from the terminals to the pasteurization plants and thence to the distributing stations. Any of the inhabitants of New York City who are awake between midnight and 3 a.m. and happen to cross the thoroughfares leading from the milk terminals in New York and New Jersey, or the bridges over the East River to Long Island, will be surprised to find that this haulage is carried on almost exclusively by giant 10-ton tractors and trailer equipments. The final delivery from house to house is made in horse wagons, but the inhabitants of New York—and many other cities—would not receive their milk and cream in time for their breakfast were it not for the part

which the motor truck plays during the silent hours of the morning.

**H**ORSES are becoming rarities on all of our big construction jobs. As a rule they are so slow that they get in each other's way and hold up the unloading operation for such material as sand, stone, cement, brick, lime, steel girders, boilers, engines and practically every other piece of material which goes into the making of a modern fire-proof structure. Motor trucks do practically all this work now.

Department stores, florists, and retailers of all kinds are relying more and more upon the motor truck to help them increase their business by providing their customers with a quick and reliable service. As the business of a department store expands and substations are established in the outlying territory, the motor truck carries the packages at night between the store and the substation in huge steel bodies locked to prevent theft. In the morning they are loaded on to smaller vehicles which serve the outlying territory.

Passing from the work of the truck to the truck itself, the 1920 commercial vehicle is not radically different from its predecessor of 1919. Steps taken toward the solution of the problem of the use of heavy fuels have progressed only slightly during the year. Mechanical changes have been few, and what changes have been made are more in the line of improvements on existing designs than innovations. Due to the experience of our war trucks abroad, there has been a tendency to strengthen such parts as steering knuckles, steering gears, springs, and spring supports. In the larger truck, especially the 5-tonners, greater pulling power at low speeds has been secured by the installation of four-speed instead of three-speed gear boxes with an especially low-gear reduction to enable the trucks to show a better performance on hills and to pull out of mire on unimproved country roads.

**T**HERE also has been a tendency to make the truck as fool-proof as possible. This has been secured by the employment of motor governors which in general regulate the speed of the truck and in some cases automatically proportion the fuel fed to the carburetor in accordance with the running conditions.

Closed drivers' cabs and self-starters have also increased in vogue, principally the former.

The owners of trucks are realizing more and more that efficient operation of the truck depends to a great degree on how the driver handles it. If the driver is comfortable, warm, and well protected from the rain and sleet, he is likely to do more work and do it better than when he is cold, wet, and dissatisfied. As a result, a very large percentage of owners are now fitting their trucks with winter cabs or with permanent cabs which are convertible for winter use by the addition of side panels of glass and wood or metal. Sensing this demand on the part of the truck owner, many of the truck makers are now selling their chassis complete with some form of inclosed cab.

The self-starter on motor trucks has gained somewhat, particularly on trucks up to 2 tons capacity. While only a few trucks in this classification are finished with self-starters as a standard equipment, many may be fitted with such apparatus at an extra charge. There is no argument against the advantages of the mechanical starter in saving fuel, wear and tear on the engine, and the physical exertion of the driver. That the use of such apparatus has not increased more rapidly and become standard on even 5-ton trucks is due to the mechanical construction of the equipment and the

question about its ability to stand up under the severe vibration imposed on solid-tired trucks when operating over rough or cobble-stoned pavements. The increased use of the pneumatic tire on trucks up to 2 tons capacity has had considerable influence on the fitting of starters on such vehicles, and the continued development of the pneumatic tire on trucks up to 5 tons capacity will undoubtedly be followed by a more general use of mechanical starters on the heavier vehicles.

Truck prices have gone up anywhere from 10 to 20 per cent. and there seems to be no likelihood of any price reduction during the coming year so long as the material and labor markets remain unchanged.

**A**SIDE from the changes in the design of the truck itself, perhaps the biggest development in highway transportation by motor vehicle is the continued development of the giant pneumatic tire. It promises to revolutionize all forms of motor-truck transport. The greatest advantage of the giant pneumatic tire is its ability to save time by increasing the speed and thereby enabling a given size of load to be delivered over the road in less time than is possible by any means previously employed. This has been made possible by the use of the cord-tire principle instead of the fabric design. Pneumatic cord tires for trucks are now made in widths of from 6 to 9 inches. These are suitable for use on trucks up to 2 or 3 tons capacity. Pneumatic tires 10 and 12 inches in diameter are fast nearing the end of their experimental periods. A 5-ton truck, mounted on 38 by 7 pneumatics in the front and 44 by 10 or 48 by 12 pneumatics in the rear, is capable of running at speeds of from twenty to twenty-five miles an hour without harm to the truck, its load or to the road, as compared with not over fifteen miles on the best kind of road with solid tires.

Aside from the greater speeds made possible by the pneumatic tire for any type or size of truck, its continued development may also result in radical changes in truck design. Experience with giant pneumatic tires on trucks of large capacity has already shown the necessity for engines with greater power. This experience has likewise indicated the possibility for considerable weight reduction in the chassis because of the greater shock-absorbing properties of the pneumatic as compared with the solid tire. And better brakes are needed. Trucks weighing 5 tons themselves and carrying 5 tons are dangerous objects when traveling at speeds close to twenty-five miles an hour, unless they are under positive control at all times. One of the possible developments is pneumatic air brakes. An adequate air pump on the engine could supply the brakes and provide for the inflation of the tire on the road to pressures as high as 140 pounds to the square inch.

**P**ASSING now from the truck itself to the truck industry and the makers, 1919 was a year in which practically all makers were faced with the problem of returning from war to peace conditions. Whereas 1917 and 1918 were eminently years of great production to meet the requirements of motorized apparatus in the war, the year 1919 showed a slight falling off in production until perhaps the end of the year. Sales organizations in the truck field were literally shot to pieces during the war in most cases, for practically every maker accepted war orders to such a large extent that he had few, if any vehicles left for commercial service. With no trucks to sell, the sales organizations were naturally depleted and the year 1919 was one in which these important sales forces had to be rebuilt from the ground up.

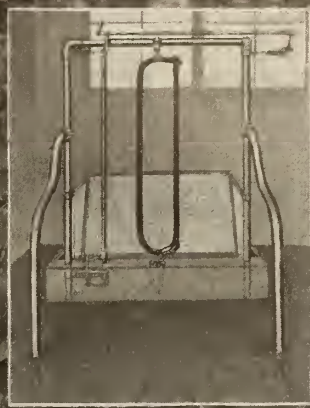

**BT  
STEEL  
STALLS  
ARE  
Galvanized**



**STEEL  
STALLS**

**Beatty Bros., Limited**

Winnipeg, Man. Fergus, Ont.  
Montreal, Que. Edmonton, Alta.  
London, Ont. St. John, N.B.  
Vancouver, B.C.  
London, England, 16 Holborn Viaduct,  
E.C.1.



# The "ACME" Line Affords Power Supremacy

SIZES:  
1 $\frac{3}{4}$ , 2 $\frac{1}{2}$ , 4, 6, 8, 10, 12  
and 15 Horse-Power

A  
C  
M  
E

AN ENGINE OF  
TESTED WORTH

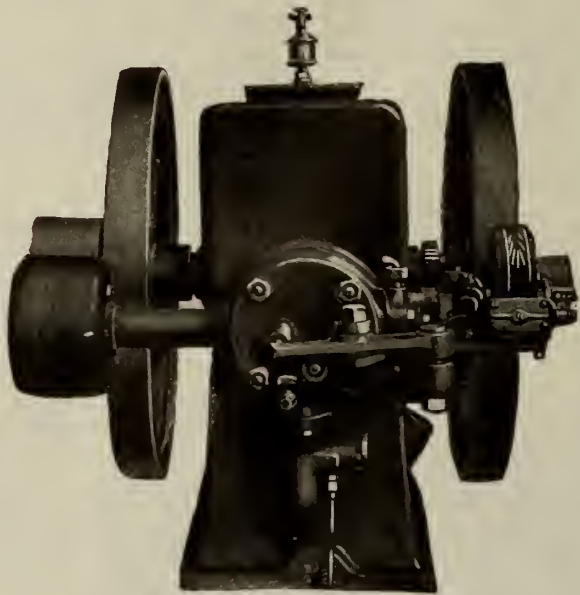

COMPLETE  
POWER PLANT

A  
C  
M  
E

14 YEARS  
ON THE MARKET—  
STILL GOING STRONG

## Absolutely Best Balanced Engine on the Market

### SOME FEATURES THAT HAVE MADE THE "ACME" FAMOUS:

Extra Heavy weight and rugged design, insuring stability and power of endurance.

Development on ratings far in excess of specifications.

Castings are sound and true, having been tested out in our own Chemical Laboratory.

Fewer moving parts and greater accessibility.

Every part is interchangeable.

Wide Range of speed control, with proper timing adjustment.

Perfect Balance enforced by heavy fly-wheel and solid construction.

Economy insured by specially designed carburetor which admits air at proper velocity in accordance with speed of engine.

Easy Starting, regardless of climate.

Webster Tri-Polar Oscillating Magneto is standard equipment, with the addition of all modern appliances.

Ideal in lines and finish.

## Comparison Assures "ACME" Selection

FISHER-WILKIE, LIMITED

--

SANDWICH, ONTARIO



# Repainting the Auto

PERHAPS one of the principal difficulties which the car owner, employed in painting an automobile encounters, is that of laying the various coats of pigment over the surface, perfectly fine and smooth and without brushmarks. Within, say, the last half dozen years, the practice has gained a foothold in the best shops, of using coats of color and other pigment, from the coarsest to the finest, a little thinner and lighter in body than formerly.

This plan, of course, sometimes makes it necessary to use an extra coat of material, but it has been found to pay in the better appearing and finer conditioned surface results. The coat of color, or other pigment, when used a little too heavy may not actually show brushmarks when it finds a place upon the surface, but it may roll up and take on a rough, cloudy effect that is out of place and produces a bad finish. Brushmarks are more often than not, the direct result of using the material excessively heavy, although, naturally, even the properly thinned coat of color may easily be brushed until it becomes brushy and coarse in appearance.

The best grades of black, for example, are almost without exception poor covering pigments, being, in the matter of composition, to no small extent, transparent. The coarser grades of black, lacking the brilliancy and tone of the finer ones, cover well, and many times, perfectly, at one coat. In the case of a fine and sensitive black, any attempt to secure perfect covering capacity at one coat by means of a heavier and thicker consistency of color, must result, therefore, in a brushy, furrowy coat which no amount of after treatment will suffice to soften down and blur.

AS in the case of the black, so must the case of all other pigments be considered. It simply resolves into the need of using the coats of color and other pigments thinner in body and consistency so that when brushed out they will lay smooth and perfectly free from brush-marks. This will help to produce a satisfactory finish at a minimum outlay of surfacing labor.

The main thing leading up to the varnish stage, and thereby making it necessary to use fewer coats of varnish, is to get the paint and color coats placed upon the surface, free from brushmarks and in as clean a shape as may be possible. This helps to make the labor of varnishing, and of surfacing the varnish, a cheaper and easier process of work. Also, in the end, it saves material.

Going back to the roughstuff coats the same adherence to the thinner coats of material is found. It has been demonstrated satisfactorily that thinner coats lessen the labor of getting a smooth surface, although it may take a coat or two extra to bring the body of the pigment up to a sufficient depth to make a level surface when it comes to rubbing the roughstuff. Whatever extra work is made by using the additional coat or two of pigment, is more than recovered when the surfacing is performed, because it will need much less rubbing to bring down the surface properly with the smoother coats. This matter of thinner coats does not, however, apply to the varnish coats, for it is most desirable to have these coats flowed on in all the volume the surface will take care of and hold.

IN the application of color it is always best to consider that lustre, brilliancy and tone are chief factors, and without regard to the covering power, these are the virtues which must be esteemed above all others. It is well to understand that color brilliancy and tone may be materially increased by the use of varnish-color as soon as the necessary density of covering material is secured. If the surface

is covered fairly well at the first coat, then the application of the varnish-color may be taken in hand. Flow on a free, generous coat of the varnish-color for the first coat; rub this lightly with a soft wool sponge moistened with water and then dipped into pumice stone flour.

This treatment will break down any existing dirt atoms and similar foreign matter. Lessen the quantity of black color for the next coat of varnish to the extent of one-half, at least. Let the last coat of rubbing varnish go without any color in its composition. Arrange to stripe on the varnish-color preceding the application of the final coat of varnish.

Always mix enough of the color for the job at one mixing in an effort to avoid using two or more batches or color upon the same surface, with the chance of having part of the surface one shade of color and another part a different shade.

At the first mixing prepare enough color for the job, and then make it a point to keep some of the color against the day of accident or emergency. Nothing mars an otherwise good job of painting quite so much as to have the field color show two or more shades, a result that can easily happen in the case of some special color when the supply runs short and a second batch must be mixed in order to supply the surface with two coats.

In the application of numerous shades of green it is necessary to brush the color one way only; cross brushing almost always produces two or more shades. This usually happens at the ends of the panels where the brush strokes are caught up. Also in the use of the various greens it is important that these colors be allowed to dry very thoroughly before varnishing over them, otherwise the shade and tone of color will appear distinctly different on the surface from the wet color in the container prior to application.

Many of these greens had best be permitted to stand over night before varnishing to insure a perfect state of drying and a certain one-color job throughout. Blues are always giving the painter, not fully familiar with their peculiarities, more or less trouble; first of all, it must be kept in mind that varnish is exceedingly injurious to the blue, most especially to the darker shades of the color. If possible, some of the color should be used in all the coats of rubbing varnish, as a means of counteracting the discoloring effects of the varnish. It is a good plan for the painter to advocate the use of the lighter tones of blue, for with these better results are certain.

OF all the blues, the ultramarine blue, light shade, is perhaps the most beautiful. There are two deeper shades of the color, but the darker shade has the disadvantage already referred to, as it suffers from the effects of varnish. The medium shade can be handled nicely if precautions are observed in application and a portion of the color employed in each of the varnish coats with the possible exception of the last coat of rubbing and the finishing coats. This will give the opportunity of striping and ornamenting on the next to the last coat of rubbing varnish.

A deep brown, or, for that matter, lampblack, will give a good ground for the ultramarine. Then for the first coat of the field color mix three ounces of color in one pound of elastic rubbing varnish for application to the largest surfaces; for the smaller surfaces a quicker drying varnish may be used.

For the second coat of varnish the quantity of blue may be reduced at least one-half. If a third coat proves desirable the varnish will not need more than an ounce of the color. The main thing, next to securing purity of shade and tone, is to have a solid and uniform shade of the color along with perfect covering results. In this

manner is brought out the wonderful brilliancy and depth of color tone characteristic of ultramarine when properly developed upon the surface.

In the preparation of the blue varnish-color the right way to proceed is to first thin the blue to quite a limpid condition with turpentine before adding the varnish. This plan will insure a perfectly uniform and evenly balanced material, with a smooth, free working condition all the way through. In fact, this is the proper way to make all varnish-color in order to have free and uniform properties.

FOR a reliable ground for any of the light yellow pigments now largely used for business motor cars and trucks a ground color of pure white makes one of the most suitable bases. The blank white ground serves to check the bleaching habit of the yellow. All of the lighter colors, including pale yellow, have a natural tendency to darken as they gradually age, and lose some of their original color, but with the white base, this habit is distinctly checked.

For a cheap, inexpensive ground for the pale yellow, use a salmon color, dull in shade. One coat of this will serve the purpose. Then apply one flat coat of the yellow, and one coat of varnish-color. The salmon perfectly blankets whatever color the ground may chance to have, and it shows a plain affinity for the yellow and is perfectly shut in by the latter.

In the work of shop mixing gray colors now so freely called for (by many automobile owners, the safe way is to break the white and the black up separately, reducing each to a cream-like consistency, and then uniting gradually to get the desired shade and the correct brushing condition.

The disadvantage or the gray pigments, especially when shop mixed, consists in the black streaking out or unduly asserting itself. The most careful mixing is necessary to overcome this tendency, and it is a wise precaution, frequently to stir the material in the container while it is being used. The gray color should also be brushed one way only, for like the greens it will show one color results under this treatment; whereas, if cross brushed at the ends of the panels a different shade is practically sure to develop.

The lake pigments are many of them exceedingly attractive colors, but the small shop painter is inclined to avoid using these splendid pigments fearing that he will fail to apply them correctly or properly prepare them for use. The main thing is to get the ground color of the right shade and rich enough to hold out the lake becomingly.

To tell the reader that lakes, as a rule, are rich in proportion to their depth, is a true statement, to be sure, but it is not definite. What the inexperienced man wants is a practical working plan to help him in making reading for the lake, applying it, etc. The ground color should be manifestly, very closely matched to the lake. For English scarlet lake, make the ground of English vermilion, the base for the latter being made of white and Indian red, adding white to the red until a positive peach blow color is reached. English crimson lake will need a deep red ground, and for Munich lake a ground of medium shade of wine color will suffice.

English purple lake should have a plain black ground. Numerous members of the lake family may be used with fine effect, over a ground of Tuscan red and drop black. For a light ground add some vermilion to Tuscan red. In the making of the surface for these lake pigments it is necessary to get it both smooth and level before applying the ground color, for after this coat is in place it will be too late to rectify surface defects. The great advantage will be in having all surface irregularities worked out prior to putting on either the ground or the field color. It should be kept in mind that these are transparent colors and any slight defect in the ground is sure to show through the lake.

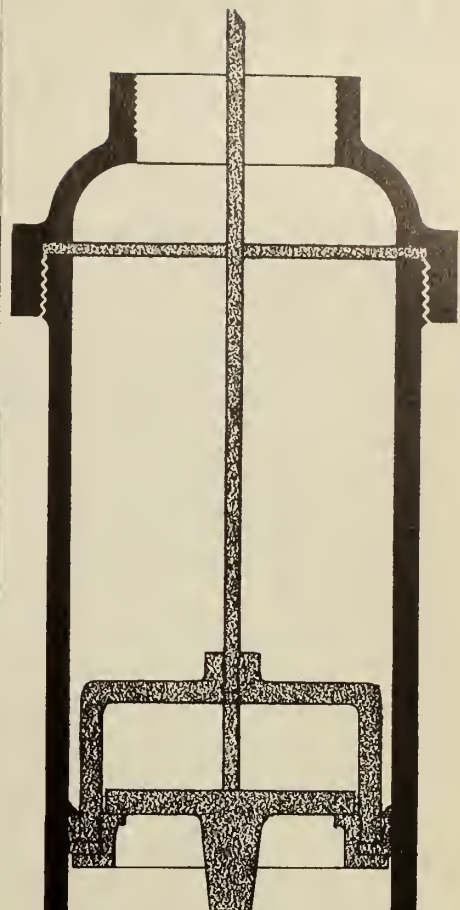

## BT CYLINDERS ARE BEST

The pumps you sell cannot work right if the cylinders are not well made.

BT Cylinders are carefully designed and manufactured in every detail. The valve seats are brass, and will not rust out. Plunger cages are made of malleable and will not crack or break. All threads are most carefully made so that they fit tight. Only the highest grade pump leathers are used.

BT Cylinders satisfy your customers.

Drop us a card for catalogue and prices.

### Beatty Bros., Limited

London, Ont. Fergus, Ont.  
Winnipeg, Man. Montreal, Que.  
St. John, N.B. Edmonton, Alta.  
Vancouver, B.C.  
London, Eng., 16 Holborn Viaduct, E.C.1

Well Pumps





# Do Clerks Really Know How to Sell?

THE accessories business which I established in 1908 now has four branches.

Last August, while visiting these branches, I discovered that some of my clerks did not know even the rudiments of salesmanship.

I happened into one of the stores, just as a customer stepped to the counter and asked for some dry cells. The clerk was a newcomer, and did not know me. I watched him sell the batteries. When the customer left, I turned to the clerk.

"If you will allow me to say so, sir, you did not take enough trouble to satisfy your last customer. You might have made a better customer of him."

The clerk looked at me astonished, as much as to say, "Who on earth are you, anyway?"

"If you think you know so much about waiting on customers," he said, "why don't you try it and show us how?"

"That's a good idea," I answered, and before the clerk had time to protest. I threw off my hat and coat, stepped behind the counter, and turned to a customer who had just entered. "May I wait on you, sir?"

"I want a couple of spark plugs." I showed the customer the various kinds we handled, and he chose a set. Then I suggested to him that it would be wise to have an extra set for emergency use. The result was that he bought two sets instead of one.

AS he started to go out, I called his attention to a lubricating oil display rack standing next to the door. I showed him a copy of a correct lubrication booklet. He was very much interested, and wanted to know all about correct lubrication. I soon convinced him that he should try it out, and succeeded in selling him a 5-gallon can of oil for his Chevrolet car.

Then I showed him the 15-gallon drum, and explained the advantages of buying a year's supply at one time. He said he would watch the result from the 5-gallon can, and if he found it would do what I claimed, he would be back after the drum. He thanked me for the attention I had given him, and went out, a very much satisfied customer.

"Say," said the clerk, when the customer had gone, "you are certainly some seller; you ought to get a job here."

It was time to make myself known. When I produced my card he burst out with a flood of apologies.

"Never mind apologizing," I said. "It's my own fault that you don't know how to sell. You've never been shown how until just now. Did you notice how I got that last customer interested, and sold him two sets of spark plugs and a 5-gallon can of Gargoyle Mobiloils, instead of merely a couple of spark plugs? That shows you the difference between being a salesman and being a mere clerk."

"Now you go at the next customer the same way. Talk to him,—be pleasant and courteous—show him some of the things we carry, besides what he asks for. You'll find that in nine out of ten cases you can sell a man more than he asks for at first. And not only that, but you can make him feel that this is a good place to trade, and he'll come back."

This incident set me thinking. If I could give one clerk a lesson in salesmanship, why couldn't I teach them all?

I COULD—and I did. I gave my clerks a series of sales talks—not long drawn-out lectures, but simply

## Manufacturers Demonstrate to Auto Specialty Salesmen

WINNIPEG.—When a firm of manufacturing agents stages a series of practical demonstrations to reveal the merit of their lines to the travellers of Winnipeg's wholesale houses it represents an advanced

informal 10 or 15 minute talks on how to sell.

During these discussions, I distributed literature about our accessories, and asked my clerks to learn certain facts about the business and the stock.

In short, I educated my clerks to know their business. I made salesmen out of them. I intend to continue giving these talks occasionally, as long as I'm in business.

Someone asked me the other day if I thought it paid me to put so much time and effort into educating my clerks. Most emphatically yes! My sales records prove it!

If you would ask me for one of the best ways to increase sales, I would answer: "Educate your clerks—first teach them the stock, then teach them how to sell it."

It may take time and effort, but it will come back to you—in bigger profits and more satisfied customers. — *The Gargoyle.*

The occasion came when the travellers were mobilized by their different firms for the usual January conference. It was a good guess that the knights of the grip needed a little tutoring on this phase of their business.

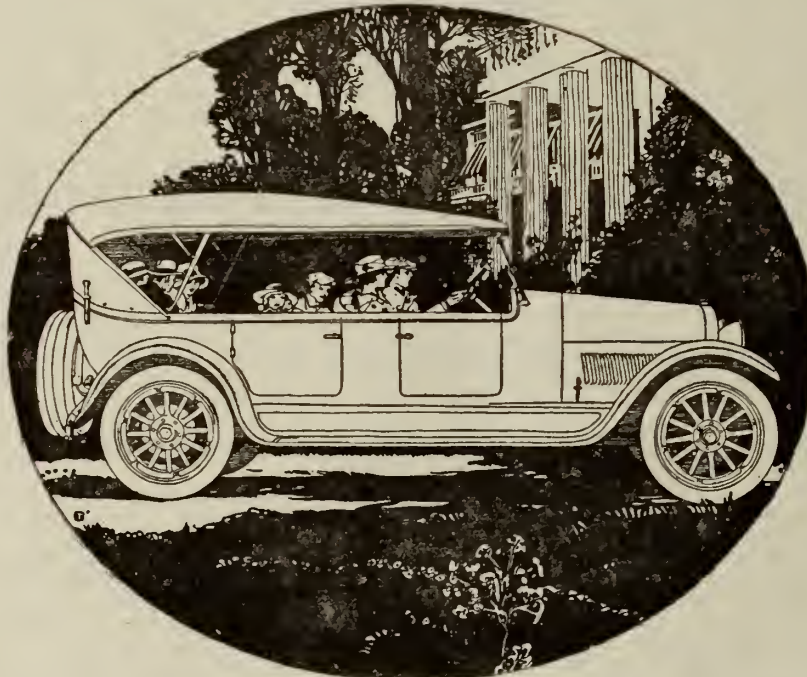

New model Case car, which is now being sold in Canada. It is handled by Croftan Storage Battery Co., 436 Yonge St., Toronto. It is manufactured by the J. I. Case Co., Racine, Wis.

method of salesmanship which is unique so far as any Western experience is concerned. The occasion and necessary inspiration presented themselves to P. A. C. McIntyre and Co., Confederation Life Building, whose particular trade sphere is largely confined to garage equipment.

and it was a propitious time to supply them with the necessary information for their prospective assaults on the garage establishments. As to the prospects for developing new trade in this direction there was little room for argument. The West stands far ahead of the East as regards the number of

### BOOST FOR BETTER ROADS!



Here's one reason. This photo, sent in by an M.T.I. subscriber, shows the Highway Road, north of Jock River, Ontario, last spring.



They're getting busy here—making a rock fill to widen the road-bed.

motor cars per 100 people, and the road men did not need to be told anything of the allurements of a practical line of garage equipment. What they did need was the first hand knowledge of the virtues and selling points of the different contrivances, and this is what they got.

THAT the different wholesale firms were alive to the value of such a demonstration was evidenced by the response. Special dates were made for travellers of each of the wholesale and jobbing houses, and the men attended in a body. As a result the benefit performance was witnessed at one time or another by the road men of the J. H. Ashdown Hardware Co., Ltd.; Wood Vallance Co., Ltd.; Marshall Wells Co., Ltd.; Canadian Fairbanks-Morse Co.; Canadian General Electric Co., Ltd.; Northern Electric Co.; General Supply Co. of Canada; Motor Products Ltd.; A. R. Williams Machinery Co. of Winnipeg, Ltd.; Great-West Saddlery Co., Ltd.; D. Ackland and Sons, Ltd.; Wilkinson Ltd.; Merrick Anderson Co., Ltd., and Plewes Ltd.

It was no behind-the-counter "stunt" which Mr. McIntyre staged for the salesmen. With his assistant, K. B. Wathen, he was present at all demonstrations, dressed in a pair of overalls and prepared for any hard work or grease oil which might encounter. Accommodation was secured in a Princess street building, and a Ford car was on hand to illustrate the different tests. Nothing was taken for granted. The travellers were "shown" exactly how the appliances worked, and the different points of merit were called to their attention. Care was taken to point where the achievements overshadowed the performances of competitive lines, and merits of construction were commented upon in an entertaining and instructive manner.

TO complete the exhibition in a four hours' session speed was required, and plenty of it was supplied. Nothing was allowed to drag, and yet thoroughness characterized the whole proceedings. On the other hand the audiences were not easy to satisfy. Questions were freely asked and careful examinations made of the work done as well as of the tools and appliances. The whole "show" was enlivened by a rapid fire repartee.

The writer was present at the demonstration given to the salesmen of The J. H. Ashdown Hardware Co., 30 of whom were on hand. The demonstrations covered all the garage equipment lines handled by McIntyre and Co., including cylinder reboring tools, jacks, auto hoists, tire tools, air compressors, and welding outfits, etc.

### RUSSELL TENDERED BANQUET

T. A. Russell, recently, was the guest at a banquet in the King Edward Hotel given in his honor by executives, office staff and foremen of the industries operating under his direction. The industries represented were the Russell Motor Car Co., Ltd., Toronto, the Willys-Overland Limited, Canada Cycle and Motor Co., Limited, Machine and Stamping Co., Ltd., and Russell Motor Car Co., Buffalo. J. R. Marlow, manager of Willys-Overland branch, Montreal, presided and introduced the speakers. J. W. Gibson and A. E. Ames proposed the toast to "Our Honored Guest," Mr. Russell responded with an optimistic address on Canada's future. Other speakers were J. F. MacKay, J. N. Shenstone, Lloyd Harris and C. R. Burt.

### SOMBRE COLORS GOING?

That the black and sombre tones of the pre-war automobiles are going out of fashion and giving place to lighter colors has been clearly shown at the great automobile show at Paris this year. Especially is this the case with limousines and coupes. The wives of car owners have no doubt influenced the change.



## ALBERTA TRUCK TRANSPORTATION COMPANY, LIMITED

We have adopted these trucks for our transportation system because they are the best trucks. They have been placed in the Class A category for low cost ton-mile which is the first and last requirement of the purchaser and the highest achievement of the truck manufacturer.

Distributors for the GARFORD, WHITE, MACK, F.W.D. and MASTER TRUCKS.

*For information on our trucks and transportation system call or write*

303 Beveridge Block, Calgary, Alberta

Phone Main 2976



## RENFREW CHANGE

"I AM a firm believer in getting one live, progressive dealer in a territory rather than two half-hearted ones," says C. J. McMahon, recently appointed Ontario sales manager of the Renfrew Machinery Co. "Through our farm paper advertising and our dealer helps we aim to help the dealer



C. J. McMAHON

to get the most out of his territory. It is very interesting to note the number of our dealers who started by ordering equipment from us in single lots and who are now ordering our scales and separators by the carload.

"I am most enthusiastic about the future of the tractor. The farmer is

sold on the tractor. The demonstrations given in this province last year proved that. Greater production is what the world is crying for and I know of nothing which has contributed more to agricultural production during the war than the tractor. The farmer through working his automobile and gas engine has become a mechanic, so the tractor is no mystery to him. If dealers would make it a point to carry a tractor in stock it would sell itself."

## HAYNES COMPANY GIVES BONUS

The Haynes Automobile Company, Kokomo, Indiana, had such a successful year in 1919 that it was decided to share the profits with the employees. Forty thousand dollars was distributed, the amount each received being based on length of service. No employee, no matter how short a time he had been on the pay roll, received less than five dollars, while many received as high as twenty dollars.

## W. W. GASKILL ROLLER-SMITH AGENT

THE Roller-Smith Company 233 Broadway, New York City, manufacturers of electrical apparatus, announces the appointment of Walter W. Gaskill, Boston, Mass., as its agent for Boston and vicinity and other parts of the New England territory. Mr. Gaskill, will supersede the P. I. Perkins Company, who represented the Roller-Smith Company in the said territory prior to the first of this year. Mr. Gaskill was graduated from Harvard in 1908 and took a one year post graduate course in 1909. In addition to the Roller-Smith lines Mr. Gaskill will handle the products of the Ward-Leonard Electric Company, Mt. Vernon, N.Y. and the Brown Instrument Company, Philadelphia, Pa.

## 1920 BURD DIRECTORY

A VERY interesting and complete piston ring directory has just been published by the Burd High Compression Ring Company, Rockford, Ill. The book has an attractive cover design in four colors. Compression rings are listed for practically every make and model of gasoline engine. In addition to the tabulation of rings and correct sizes for every type of engine, the directory contains complete instructions for the installation of piston rings, helpful hints about motor troubles and several useful tables.

## HAYWARD JOINS AYERS

HARRY HAYWARD, who has an international reputation as an agricultural expert, has joined the staff of N. W. Ayer and Son of Philadelphia. His services will be at the disposal of the agricultural clients of the Ayer advertising agency.

## CANADIAN FIRESTONE'S NEW CHIEF

R. H. JEFFERS has been appointed general manager of the Firestone Tire and Rubber Co., of Canada, Limited, at Hamilton, Ont. The company has purchased a 135-acre site, which will be known as Bartonville. On one half of the site will be built a large plant with a floor space of about 320,000 square feet. The remainder of the site will be used for model houses, community halls, and stores for the employees of the company. The Canadian Firestone Company is capitalized at five million dollars and will employ about three thousand men.

## G-O VICE-PRESIDENT

F. B. CLARK, who, until December 31, 1919, was Eastern sales manager for the General Ordnance Co., has

been promoted to vice-president of the same company, and assumed his new duties January 1, 1920.

Mr. Clark has had charge of the Eastern Sales of the G-O Tractor since he resigned his commission as Major in the Ordnance Department of the army, where he had charge of a special department for small arms ammunition production.



F. B. CLARK

For practically thirteen years previous to this he was associated with the Remington Arms-Union Metallic Cartridge Co., occupying various progressive positions, including that of general manager of the U. M. C. Swanton Works.

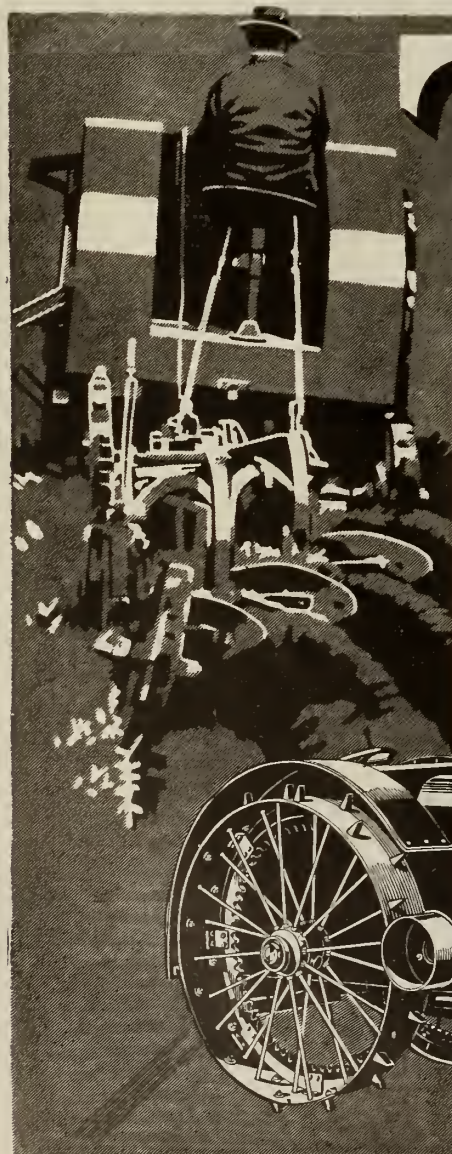

# TURNER

## Simplicity

### The Tractor You Sell

is only as attractive as the tractor is tried and proven, practicable, and economical in operation. Continued sales, easy service demands, and contract renewals throughout the country prove that Turner success is hinged upon built-in principles of proven merit, of economy and service.

Turner Simplicity has met the demand for a tractor that can be relied upon for constant performance on a wide range of work. On drawbar and pulley jobs the efficient delivery of power to wheels and belt has won Turner lasting reputation. Its reserve power to meet overload conditions, its low fuel costs, easy handling and thorough dust protection, contribute to the increasing sales records that have grown apace with production facilities.

It is significant that the Turner is handled by leading distributors the country over. For immediate action on territory proposition—address

**The Turner Manufacturing Co.**

441 Lake Street, PORT WASHINGTON, WS.



# MATTHEW MOODY SAWS

*Handy, Strong  
and Durable*

**First-Class Machines at Low  
Prices**

*The Moody  
Drag Saw  
Machine*

*Improved  
Design*

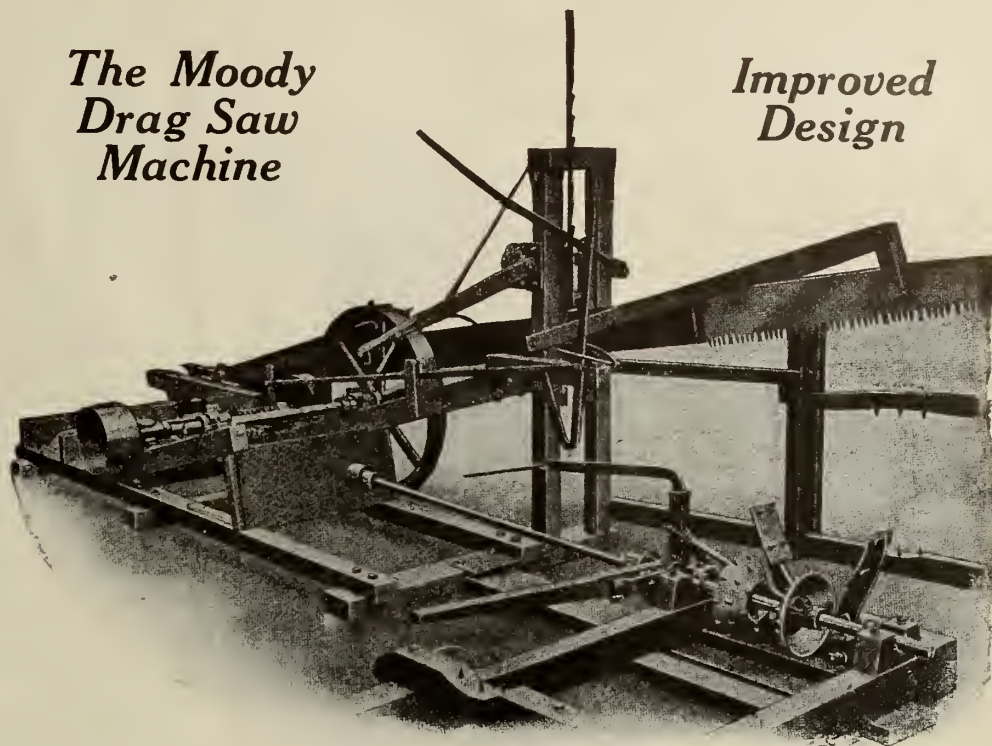

## **The Moody Long Swing Table Saw**

Cutting qualities are not the only essentials to be considered in selecting a good circular saw. Consideration should be given to its safety in operation. This Moody Long Swing Table Saw is designed to be absolutely safe as well as to possess superior cutting qualities. Carefully seasoned hardwood, of ample size and weight, strongly braced and bolted together, give it exceptional strength — no gears, no complicated pieces. Log tables are plated with heavy steel plates and every saw that leaves our factory is equipped with a safety strap around the shaft close up to the circular saw, a precaution against accident in case box of saw shaft or bolt should break.

The Machine could not be made safer.

Farmers everywhere are now appreciating the advantage and profit in owning and operating a sawing machine of their own. They can cut their own wood and make money cutting their neighbor's wood, too. **DEALERS**, there is your opportunity. Sell the well-known Matthew Moody Sawing Machines and reap the handsome profits that always come to a dealer handling a reliable line.

**Matthew Moody saws embody all the essential points necessary to attract buyers—practical, convenient, fool-proof, advanced in design and very moderate priced.**

## **The Moody Improved Drag Saw Machine**

Recent and ingenious improvements made on this drag saw have made it superior in service to any machine of its kind on the market. By means of a new special device the saw is put to rest and the self feed continues running. No stopping is necessary now in moving the log. There's no inconvenience or delay of any kind. Our pressure lever is another new improvement, which can be used with convenience when required. Still another new and important feature is the log holder. It permits the convenient cutting of short cord-wood without the slightest danger. The whole outfit is made stable and rigid by a still hardwood connecting plank.

No other machine compares with it for service.

Better service and greater value are not obtainable than that represented in Moody saws or other Moody farm implements! You can order a Moody Machine with full assurance of quality, service and value.

Are you acquainted with our full line of machines? Whether you are or not, send for our latest catalogue.

*The MOODY Long Swing  
Table Saw*

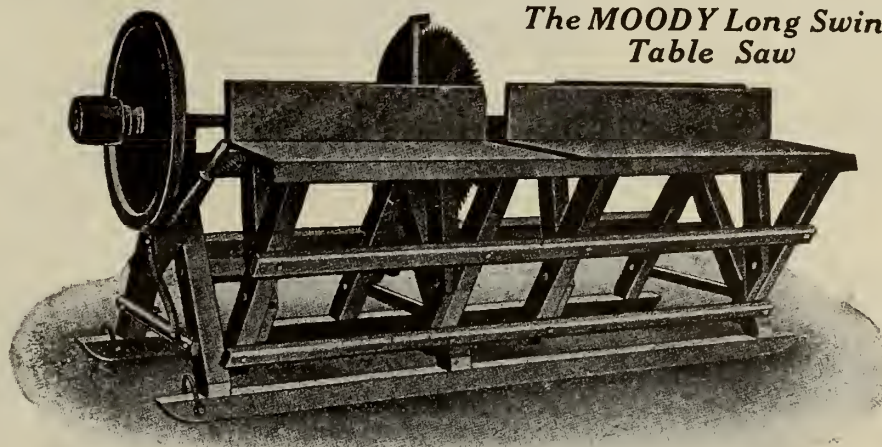

**MATTHEW MOODY & SONS CO.,** HEAD OFFICE, **Terrebonne, Que.**

REPRESENTED IN THE WEST BY

Messrs. Francoeur Bros., Camrose, Alta.

New Home Machinery Company, Saskatoon, Sask.

Mitchell's Hardware Company, Brandon, Man.



## WHO IS LOGICAL DEALER?

THE controversy which raged—in some waters—a season or so ago as to whether the implement dealer or the automobile man would get the tractor business has been subsiding. The question is settling itself, as the *Implement and Tractor Trade Journal* always thought it would. The better class of implement dealers, for the most part, have caught the vision of power farming and, what is somewhat more important, they have attached themselves in a thoroughgoing and practical way to the new business, determined to push it in their long-established capacity as experienced advisers to the farmer.

Automobile men, in many instances, have entered and retired from the tractor business, discovering their limitations and realizing that there is a world of difference between automobile salesmanship and service, and farm equipment salesmanship and service. So far as we have been able to see, the main point on which the real farm implement trade should be solicitous is that the tractor business gets into competent hands. If an automobile dealer fits himself to furnish the exacting service required by farmers, he is sure to be welcomed into the farm equipment fraternity, for his very act of taking on tractors and power farming lines reclassifies him as a merchandiser of farm equipment.

It is interesting to observe that this same controversy now has its counterpart in England, where the motor interests are claiming the tractor business for their own. T. R. Actour, the *Implement and Tractor Trade Journal's* English correspondent, reports that, as was the case in this country, the motor trade's concern about the tractor was born of the wartime necessity for diverting attention from passenger cars to "essentials." The tractor happened to be the most essential domestic machine in any way allied with the motor car, so with commendable versatility, both the automobile manufacturers and dealers turned their energies into the new power farming channel.

It has availed little for the partisans of either the farm equipment field or the motor field to debate this question so hotly, either in America or England. All the "arguments" in the world cannot change the face of the fundamental "facts." These surround the central circumstance that the tractor is a farmer's implement and those who would sell it to the farmer must be familiar with the farmer's problems and needs. If the automobile man can qualify with the respect to this paramount requirement, he immediately becomes something other than an automobile man—no less than a farm equipment dealer. To this evolution nobody in the established farm equipment trade has the slightest objection. On the other hand, the "new blood" is especially esteemed because of the contributions of initiative and high-power selling methods it may bring into the trade.—From *Implement and Tractor Trade Journal*.

## GRAY TRACTOR IN WEST

THE "Gray Wide Drive Drum Tractor," handled by the Gray Tractor Co., Winnipeg, although a practically new one this year in the Canadian field, is the result of development begun as far back as 1908.

The characteristic feature of the tractor is that of a wide drive drum at the rear instead of two wheels. The advantages claimed for it are the additional traction afforded by the drum and the distribution of the weight over a larger area, thus reducing the objectionable feature of soil packing, which argument is so often advanced by farmers as a great objection to "power farming." This feature is claimed to be of particular advantage at seed bed preparation as packers, harrows, discs, drills and cultivators can be hitched to the tractor and a perfect seed bed made without leaving wheel marks or ruts in

the field. In plowing also they claim the advantage of rolling the soil ahead of the plows, crushing all weeds, stubble and vegetation flat so that perfect furrows can be turned and an even surface will be found in the finished field with all trash buried.

Gray Tractor operators have competed successfully at plowing matches.



W. ALBERT PRUGH,  
Appointed Manager Gray Tractor Co.,  
Winnipeg.

Bert Lytle of High Bluff, Manitoba, won first prize in the Four Plow Class at the Manitoba Provincial Plowing Match, held at Portage la Prairie on June 18 and 19, 1919.

## VALUE OF DEALERS' ASSOCIATION

ROBERT W. Martland of Oakland aroused enthusiasm at a recent auto convention with a story of how the California Automobile Trade Association has grown and benefited the trade in that state. He said it started five years ago in Oakland with 68 members and in a month had four local associations and 210 members. To-day there are 42 locals with 2,700 members. He stated that the association endeavors to teach the trade that there is such a thing as overhead and that the public is entitled to courtesy and fair treatment. The public has approved of these principles and the association has made it possible for members to take advantage of this approval by lending to members an insignia which tells the motorist that a garage is a member.

If any car owner receives what he considers unfair treatment, he may complain to headquarters and he will receive redress. If the dealer or garageman is found to have overcharged, he must make a refund to the customer or his insignia is taken away from him.

Martland told of instances in which association effort has led to the establishments of supply departments in garages with an increase in business from \$75 to \$1,000 a month.

He said that one day in the San Joaquin Valley he found a clean garage and said to the man: "It's a wonder you don't carry accessories." In a closet the garageman showed him a \$1,000 in staples under lock and key and explained that if he put them outside some one would steal them. This man's stock in seven months increased to \$2,500 and his business from \$75 to \$1,000 a month.

In Pomona, two years ago, was a man with an 80-ft. front and 25 ft. of it devoted to a display window which was far from clean. To-day the window is clean, there are 32 ft. of show-cases on the driveway and the man is making \$12,000 a year out of supplies. Martland told of another man who

began in 1912 and in the first year made \$5,000, but at the end of June, 1917, he was a thousand dollars worse off than he was when he started. Through association effort his business was so improved that in December, 1917, he deposited \$13,000 in the bank and bought a \$690 cash register.

Last September the California trade went on a cash basis to the extent of about 75 per cent. of the association membership.

Martland urged the jobbers to go home and lend all the assistance they could in the organizing of the dealers and garagemen in their territories.

## TESTING TRACTORS IN NEBRASKA

PROFESSORS L. W. Chase, O. W. Sjogren and E. E. Brackett, constituting the board of engineers in charge of the tractor tests to be conducted under the new state law by the University of Nebraska, Lincoln, have outlined the following tests to which all tractors sold in Nebraska will be subjected, by Claude K. Shedd, engineer-in-charge, and his assistants:

(a) Draw-bar work at from 1/3 load to full load for 12 hours. This test gives opportunity for the tractor to "limber up."

(b) Brake horse-power test at rated load and rated speed for two hours. This test will show whether or not the tractor will carry its rated load on the belt; also, show fuel consumption at rated load.

(c) Brake horse-power test at load varying from maximum to no load, with all engine adjustments, as in test (b), for one hour. This will show fuel consumption and speed control on varying load.

(d) Brake horse-power test at maximum load for one hour with governor set as in test (b) and carburetor adjusted to give maximum power. This will show the maximum horse-power of the tractor on the belt.

(e) Brake horse-power test at 1/2 load for one hour with governor set as in test (b) and carburetor adjusted for most economical operations at one-half load. This test will show fuel consumption at one-half load.

(f) Draw-bar horse-power test at rated load for ten hours. This will be made on a half-mile cinder track and will show whether or not the tractor will carry its rated draw-bar load continuously, also show fuel consumption on draw-bar work.

(g) Maximum draw-bar horse-power test. This test will be a series of 50-foot runs with an increase of load for each run until the engine is overloaded or the drive wheels slip excessively.



The "speed-bug's" dream of Heaven.

(h) Miscellaneous. This may include investigation of work on inclines, turning radius, effectiveness of brakes, or any other feature of the tractor which may seem to require special observation.

(i) Tractors will be under observation for endurance throughout the complete test as outlined above.

## CUSHMAN HANDLES LAUSON

THE John Lauson Mfg. Company of New Holstein, Wis., announce that they have completed a contract with the Cushman Motor Works of Winnipeg, Man., Canada, to distribute Lauson tractors in Western Canada. The Cushman Motor Works of Winnipeg are a branch house of the Cushman Motor Works of Lincoln, Nebr., manufacturers of the well-known Cushman engines.

A. E. Donovan of the Winnipeg office, who is well versed in power farming, machinery and tractors, directs the sales of the Lauson in Western Canada.

The Saskatchewan Lauson Tractor Co. of Saskatoon, and McCleneghan & Taylor of Lethbridge, Alta., distributors, who have been handling the Lauson for some time, will work hand in hand with the Cushman Motor Works. Complete stock of tractors and repair parts will be carried at Winnipeg as well as throughout the three provinces covered, and Lauson users and dealers can expect good service.

—Open Edmonton Branch

## OPEN EDMONTON BRANCH

THE United Engines and Threshers Ltd., Calgary and Edmonton, report a very successful year, in spite of somewhat adverse crop circumstances in Southern Alberta. This company was organized in May, 1919, and handles the Gould, Shapley and Muir line of gas engines, windmills and the Beaver tractor. They are also Alberta agents for the Waterloo Manufacturing Co. of Portage la Prairie, who have the Canadian distribution for the Rock Island Plow Co.'s Herder tractor. They are distributors for the Maple Leaf Rubber Co. and recently formed a connection with the Genco Electrical Engineering Co. Selling the Genco lighting plant, in conjunction with their other lines. A branch office and warehouse was recently opened at Edmonton, the head office being located at Calgary. T. R. Scott is the managing director.

## GETS OVERLAND, ALBERTA, DISTRIBUTORSHIP

THE Great West Motors, Ltd., P. J. Kennedy, manager, has recently obtained the entire province of Alberta for Overland distribution. Mr. Kennedy has established one of the finest salesrooms in the West at Calgary and is noted for unique window displays. He is opening an office and salesroom at Edmonton, and is enlarging his organization considerably. The Great West Motors is one of the liveliest sales organizations in Western Canada, and now that Mr. Kennedy has obtained the entire province, will go after spring trade more aggressively than ever. The big difficulty at the present time, he says is in getting the cars, as the Overland 4 has gone strong in this territory.

## CALGARY MOTOR CHANGE

LEAVING the retail trade entirely, the Motor Car Supply Co., L. A. Cavanagh, manager, has moved its head offices to a Ninth Avenue warehouse. The company will confine itself exclusively to the wholesale trade in future, the retail business having been taken over by Capt. J. J. Jamieson, under the name of Jamieson Motors, Ltd. The Lethbridge and Edmonton branches of the Motor Car Supply Co. will be maintained as usual.

## IMPLEMENT MANUFACTURERS PLAN PROPAGANDA WORK

AT a recent meeting of manufacturers of farm implements held in Quebec, to discuss the best means of promoting the use of modern implements, to further increase production and facilitate the work on farms, it was decided to adopt a propaganda campaign. This campaign is expected to start immediately.



**ADVANCE-RUMELY CONVENTION**

LARGE numbers of Canadian Advance-Rumely dealers from Western Canada are attending the two-weeks tractor schools which are being held during the winter months by the Advance-Rumely tractor company at the head office, La Porte, Indiana. G. W. Matheson, of Craik, Sask., one of the members of the executive of the Implement Dealers' Association of Saskatchewan, paid a visit early in February to the editorial offices of M. T. I. and estimates that at the various schools there will be about 200 to 300 Canadian dealers in attendance. Mr. Matheson, who has handled tractors since 1909 and can therefore be termed a real veteran in this game, is very enthusiastic over the value of the Advance-Rumely School, and favors the holding in Canada of similar schools—schools of more value to dealers, and on a more pretentious scale than hitherto held in this country.

**UNIVERSAL JOINTED VALVE GRINDER**

THE Hudson Universal Jointed Valve Grinder is especially useful in grinding the valves on the fourth cylinder of Ford engines, which are difficult to reach with the usual solid grinder. It is manufactured by the Hudson Motor Specialties Co., Philadelphia, Pa., who say that it is fitted with a universal joint, which allows the working end a certain amount of motion in any direction relative to the shank. When the shank is being revolved between the palms of the operator the entire valve is accurately ground.

The tool is of simple construction, and durable. The universal joint is formed by simply pinning the tool head to the shank with a pin which is much smaller than the hole through the shank. A coiled spring between the head and the shoulder of the shank takes up all looseness, and holds the head normally square with the shank.

**AN ALIGNMENT TEST**

TO test the alignment of the front wheels a gage is made of a rod sliding within a tube. A hole is drilled and threaded in the tube so that a set screw can be tightened against the rod



to hold it in any position.—F. E. Patch, McKee Sales & Service Co., Sherbooke, Quebec, Can.

**B. AND D. CHANGES**

THE Black and Decker Mfg. Co., Baltimore, Md., have established a branch office at 6523 Euclid Avenue, Cleveland, Ohio.

Garth A. Dodge, formerly connected with the Austin Company, at their Cleveland headquarters, has recently joined the B. and D. forces, in the capacity of branch manager for the states of Ohio and Indiana, and will be in charge of the Cleveland branch.

**NEW TRUCK COMPANY FORMED**

THE Alberta Truck Transportation Company, Limited, with head offices in Calgary, has been formed recently with a capitalization of \$150,000.00. The new company will handle the Carford, White, Master Mack and F. W. D. lines and in the near future will operate a fleet of fifty motor trucks for daily freight, covering such routes as Calgary to Medicine Hat, Calgary to Lethbridge and Calgary to Banff, taking in all the intermediate towns.

**News of the Trade**

**CORNWALL.**—R. J. Furzey has secured the agency for the Maxwell car.

**TORONTO.**—James Francis has succeeded B. W. Lilson in Eastern Ontario territory for the Moline tractor.

**GANANOQUE.**—Messrs. H. Wilson and Sons, who have the Buick agency, have now taken on the agency for the Gray-Dort cars.

**BROCKVILLE.**—The Phillips and Soper Motor Car Company has added a battery service department to their up-to-date garage.

**TORONTO.**—E. S. Kelly, of Picton, Ont., who has been distributor for Moline tractors in Prince Edward county, has taken a position on the service staff of Willys-Overland for Moline tractors in territory east of Toronto.

**TORONTO.**—F. C. Wilson, Ontario service manager of Willys-Overland, Limited (tractor division), has returned from Moline, Ill., where he spent two weeks in the head office in the interests of service.

**RENFREW.**—W. F. Webster, formerly connected with the La Crosse Tractor Company, has been appointed by the Renfrew Machinery Company to be in charge of their tractor sales for Western Ontario. His headquarters will be at London, Ont.

**RENFREW.**—C. Chase, who has charge of the United States business of the Renfrew Machinery Company, attended the Renfrew Machinery Company's convention here last month. Mr. Chase has also built up an extensive foreign business outside of United States for the Renfrew lines.

**NIAGARA-ON-THE-LAKE.**—A. R. Inskeep has taken F. Currie into partnership with him in his business of automobiles, repairs and supplies. The new partners have installed an oxy-acetylene welding plant and are now equipped to handle all kinds of automobile, farm implement and welding repairs.

**BROCKVILLE.**—Messrs. Blacock and Co. have installed a battery charging outfit which is said to be the equal of any outfit in Eastern Canada. The outfit has a charging capacity of 80 batteries at one time. It consists of a Fairbanks-Morse 5 H.P. motor, a 3½ kilowatt generator, and four charging panels with rheostat.

**INDIAN HEAD.**—The Union Garage and Machine Shop Co. has secured the agency for the new Overland "4."

**REGIA.**—Auto vendors in Saskatchewan, by the provisions of a bill now before the Legislature, must file a list of prices of cars and parts with the Provincial Secretary early in February and keep the list corrected from time to time.

**NANAIMO.**—The Sampson Motor Company is installing an up-to-date system for storing accessories and repair parts.

**VACOUVER.**—R. H. D. Couper, formerly of Moose Jaw, has opened an up-to-date garage at 6172 Fraser Street, South Vancouver.

**NANAIMO.**—H. E. Dendoff, oxy-acetylene welder, is equipping his plant for the manufacture of auto springs for any make of car.

**DUNCAN.**—The Central Garage is installing a battery service station. This firm has a large tourist trade and is especially well equipped.

**NANAIMO.**—J. A. Irvine, proprietor of Nanaimo Vulcanizing Works, is enlarging his plant to take care of his rapidly increasing business.

**NANAIMO.**—Hugh Gibson, dealer in automobiles, accessories and bicycles, is moving into larger quarters and contemplates increasing his stock.

**NANAIMO.**—Weeks Motors, Limited, agents for Chevrolet, Dodge, Chalmers, Hudson and Cadillac cars, report a record year for 1919. They sold 195 new cars from January, 1919, to January, 1920.

**Sell the Separator that the Farmer ought to have---THE VIKING**

Farmers should have the VIKING because it is

- simple
- durable
- fewer parts to wear out
- runs easier

*The VIKING makes the dealer more profit on his investment, sells readily, and backed by the best selling and service organization.*

We own the exclusive straight disc skimming device which insures ease of operation—closer skimming and most easily washed device made.

If you want the best profit-making line of separators on the market—**BE the VIKING dealer in your territory.**

**Write us to-day for VIKING dealer proposition.**

Dept. BJ

**Swedish Separator Company**

Montreal: - 422 Power Bldg.

Winnipeg: - 714 Confederation Life Bldg.



**OPPORTUNITY**

**Mr. Dealer, are you taking advantage of it?**

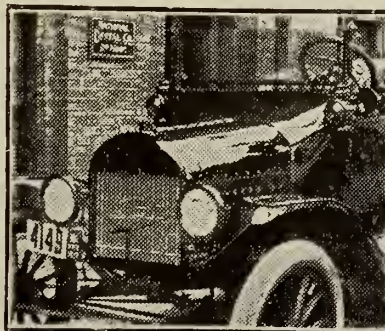

The demand for the Burrowes Patented de Luxe FORD CAR STREAMLINE HOOD is greater than ever.

Quick sales and big profits.

Fits Ford Cars previous to 1917.

Order in advance for prompt delivery or write for Dealer's Prices.

**The Burrowes Mfg. Co., 611 King St. W., Toronto, Ont.**

**The Highway to Success**

Every young man or woman needs an education to get ahead in life. But many cannot afford it.

Here is YOUR opportunity to earn the money you need, in your spare time. We need representatives in all parts of Canada to take subscriptions to MACLEAN'S MAGAZINE and FARMERS' MAGAZINE—and we pay you well.

**Sign this coupon and mail it now**

The MacLean Publishing Company,  
Agency Division, Toronto.

Please send full particulars re your money-making plans for me.

Name .....

Address .....



# Hold Tite Nut Lock

*The nut that holds  
on like grim death.*

*No vibration can  
loosen it.*



*A safeguard where-  
ever a nut needs  
locking.*

**SIMPLE  
INEXPENSIVE  
POSITIVE**

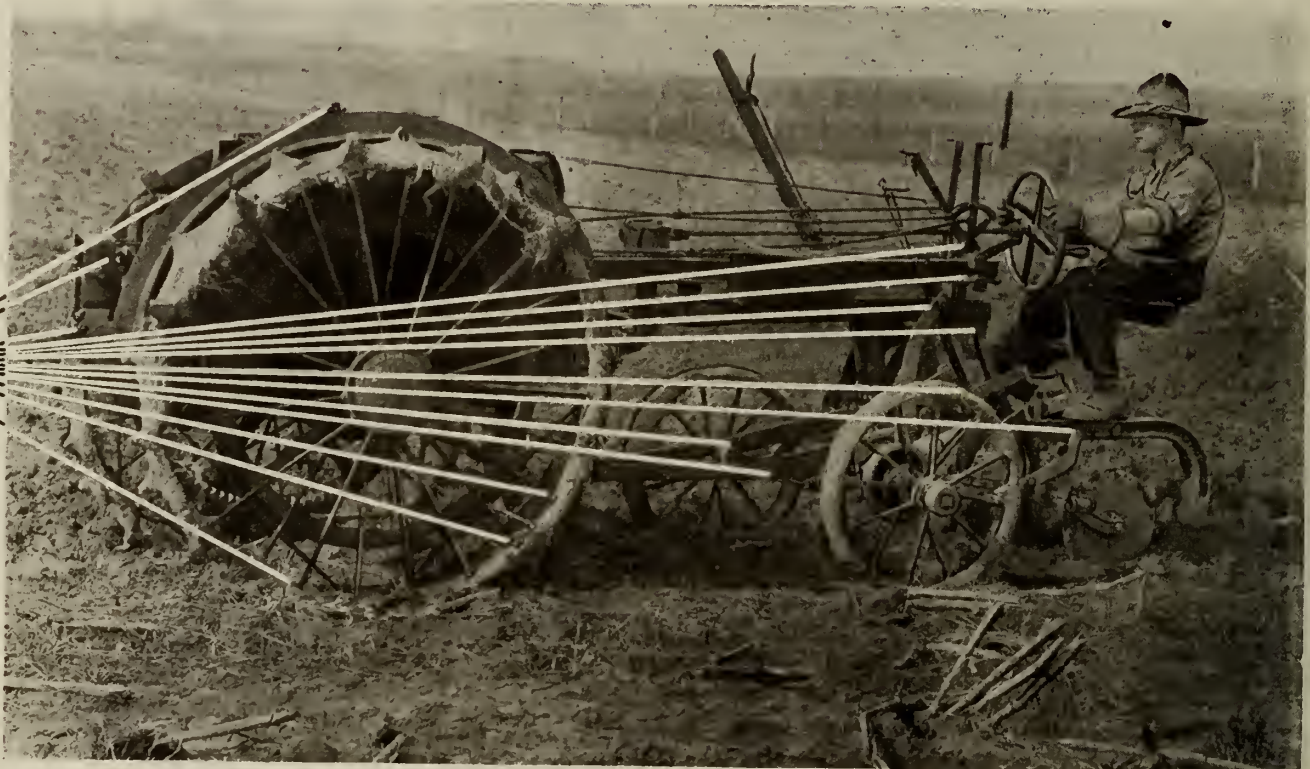

**For Automobiles, Trucks, Tractors, Stationary Engines  
and all kinds of Agricultural Implements**

Loose fastenings are the first signs of old age in any machine. Make sure that the machines you handle have a long life. It means more and better business for you.



Some of the  
Satisfied Users  
of the Hold Tite  
Nut Lock

Dominion Oilcloth  
Co.  
Montreal Tramways  
Carter White Lead  
Co.  
Canadian Transfer  
Co., Ltd.  
A. C. Lariviere Auto-  
mobile Shop  
St. Lawrence Sugar  
Refinery  
Northern Electric  
Co., Ltd.

Simple Method of Applying

*FIRST*

Knowing the Size Bolt—  
Use Same Size Nut Lock  
Place Over Bolt — THIS WAY

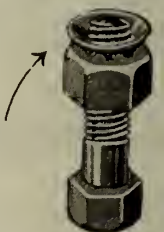

*SECOND*

Screw Another Nut Down  
onto Nut Lock and Depress It  
THIS WAY

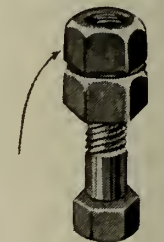

*THIRD*

Remove Second Nut and  
Nut Lock will Lock  
THIS WAY



Write to-day for full particulars to

**EDWARD A. ROBINSON CO., LIMITED**

228 CRAIG ST. W.

AMERICAN FACTORY: 166 Montague St., BROOKLYN, N.Y.

MONTREAL



**MOTOR HANDLING MACHINE**

THIS machine is especially constructed to handle any motor without the use of special bolts or blocking, as the universal clamping heads adjust themselves to any position or shape. The makers say it combines a crane, swinging engine stand, rear axle vise, and a bearing burning-in machine, in one. As the motor holder is supported by one end only, the engine can be revolved in either direction a complete revolution, permitting the workman to get at the engine at every angle. One man with the aid of the crane can remove or install any engine in a chassis.

The motor attachment is detachable and has been especially designed for portable floor jobs. All parts of the handling machine are made from semi-steel, and the projecting arms or housings are reinforced with a heavy rod iron band.

In operation, the load is raised with a lifting crank or gear shaft, and can be locked at any point by means of pawl and ratchet, the yoke rests on an eccentric axle. The axle is thrown back by raising the handle against the arm, and weight of machine then rests on the front wheels. The height of the crane is 7 ft. 6 in., and the lift 6 ft. 4 in. Overhang is 3 ft. 6 in. and the capacity 2,500 lbs.

The burning-in machine comprise a three horsepower motor, back geared 9 to 1 ratio, which, the makers say, can be detached from the machine and used for cranking a stiff motor in a car, locating ignition troubles, running or burning in bearings, without removing the motor from the car. The handling machine is manufactured by the Western Manufacturing Co., Oskaloosa, Iowa.

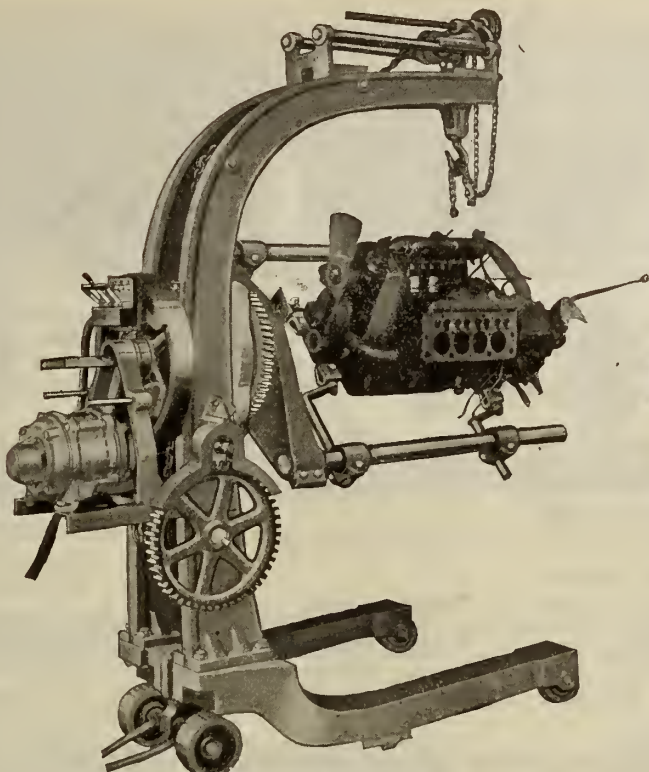

Eco Universal Motor Handling Machine.



Motalarm

The heater can be closed entirely for summer driving. It is 9 3/4 inches long and 5 1/2 inches wide, and finished in nickel. The only labor required in installing is the sawing of a hole in the floor-board and fastening the six screws.

**THE MOTALARM**

THIS is a signal for use on automobiles which is operated by steam and air pressure and only functions when the water runs low in the radiator. When the level drops to a certain point, the steam operates a whistle which continues to shrill until the radiator is perfectly dry and then keeps up the signal until the radiator is filled. The makers say when the signal is first heard there is sufficient water to travel 30 miles. It is easy to install and can be attached to the radiator cap of any car.

In addition to the warning signal, the pipe which goes down into the tank is coated with a specially-prepared paint to which the water adheres, and by lifting it out the water level can be determined. It is manufactured by The Motalarm Corporation, 1777 Broadway, New York City.

**VALVE SPRING RELEASE**

THE Mertz valve spring release, adapted for use on all types of motors, is manufactured by the H. B. Mertz Co., 1408 Rutherford Avenue, Pittsburgh, Pa. The release consists of a vertical bar on which a sliding arm locks automatically at the desired position. On the lower end of the bar is a fork which straddles the lower end of the valve stem. This fork has an adjustable gage for centering around the stem. A hand screw on the sliding arm has a swivel button with a centre point attached which centres on the valve head.

The valve spring release is made in five sizes. It is constructed of malleable iron and still is light in weight and—the makers say—is quickly disassembled for small space in the tool chest.

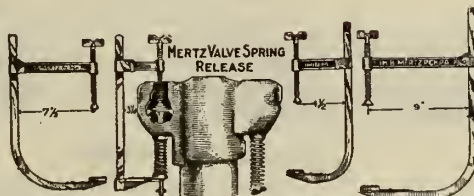

Valve Spring Release

**MANLEY GARAGE CRANE**

THIS is a crane designed for all lifting purposes inside the garage. It is manufactured by the Manley Manufacturing Co., York, Pa., who say that a half dozen different pieces of equipment are combined in one. It may be used inside, the service station and because of its portability can be used as a wrecking crane and for towing of all kinds. It can be taken down and put together again by two men in five minutes and so can be changed instantly into a wrecking crane and mounted on a service truck with the beam at any desired angle.

The capability of the crane when used on the floor is 1 1/2 tons and when used as a wrecking crane is two tons.

It is powerfully built and the materials used in the construction make it practically unbreakable.

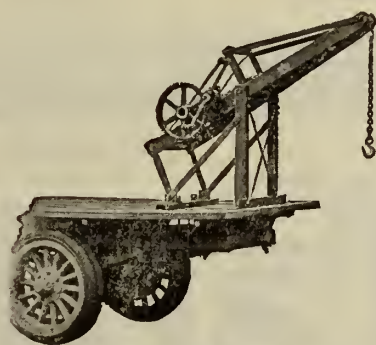

Manley Garage Crane

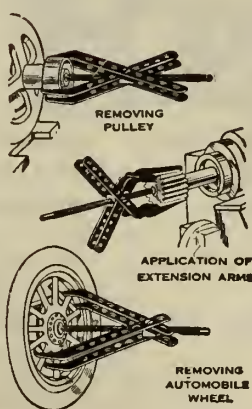

Little Giant Puller

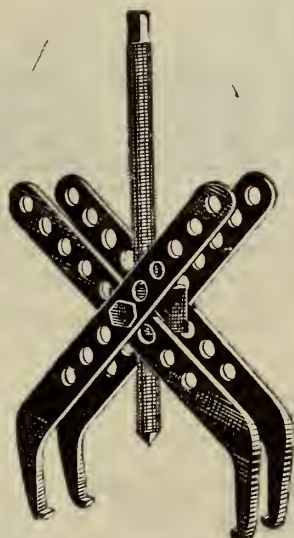

Little Giant Puller



Spark Plug.

**LITTLE GIANT PULLER**

THE Little Giant Puller, made by the Premier Motor Products Company, Robey Street and Irving Park Boulevard, Chicago, is designed for removing automobile gears, wheels and pulleys. The makers say it can be adjusted for inside and outside, and all sorts of angular pulls. It has long, strong and quickly adjustable arms to get into cramped and limited spaces where a pull has to be made. It is easily adjustable up to 13 inches in diameter. The puller is distributed in Canada by the Cochrane & Stephenson Co., Ltd., 602 Block Avenue, Winnipeg.

**DEFLECTOR SPARK PLUG**

THE Norris Company, 332 South La Salle Street, Chicago, Ill., are putting on the Canadian market, through their agents, The Vimy Supply Co., 585 College Street, Toronto, Ont., a new spark plug, called the Unique Deflector Spark Plug, which they claim is a real practical spark plug of merit, that will give satisfaction and that it is economical as well as efficient.

The steel body is massive, sturdy and strongly made of high-grade material and the porcelain heavy and of good quality, and also that a cylinder throwing oil does not interfere with its operation.

The working description given is as follows: The concave deflector disc is designed to throw off from the sparking area the soot-forming elements in order to prevent choking up with carbon. The firing area being the only opening to the chamber between the disc in porcelain, it is intended that the suction created by the cylinder action, in conjunction with the explosion, should eject and sweep clear, intruding particles of carbon. The circular firing area provides a 360 degree circle of flaming sparks, which flash around the edge of the deflector, giving thorough ignition.

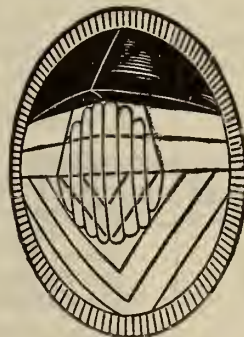

Violet Ray Lens

**VIOLET RAY LENS**

THE demand for a headlight to light up the road ahead of the motorist that would eliminate the glaring red and yellow rays, and still retain the power of the lights, has been met by the Violet Ray Headlight Lens, say the makers, the L. E. Glass Co., Mt. Pleasant, Pa.

The manufacturers have made exhaustive laboratory experiments with the constituents of light and its projection, resulting in the development of a steel-blue glass which, by eliminating the glaring red and yellow rays, produces in effect an artificial daylight. The makers say it is attractive and adds to the appearance of the car. It is easy to install, and is made in all sizes.

**SHURNUFF HEATER**

SHURNUFF Manufacturing Co., 3147 Locust Street, St. Louis, Mo., have put on the market an automobile heater designed for all makes of cars. The makers say the heater is easily installed, and is opened and closed by a touch of the foot, like a hot-air furnace register. It utilizes the heat from the exhaust pipe and engine when installed in front, and the heat from the muffler when used in the rear.



Automobile Heater.



# CANADIAN Motor, Tractor and Implement Trade Journal BUYERS DIRECTORY

This directory will help you with your buying and your planning. The advertisers listed here are thoroughly reliable and leaders in their respective fields. They are looking for live, wide-awake representatives. Study their advertisements carefully because they contain valuable information which will dovetail with your plans. We are glad to go to the trouble of arranging this list—to make it easy for you to select new lines. If it so happens that what you want is not here, write us, and we will tell you where to get it.

## ACCESSORIES

Chapman Double Ball Bearings Co., of Canada, Toronto.  
R. F. Sedgely, Inc., Philadelphia, Pa.  
The Burrows Mfg. Co., Ltd., Toronto.  
Can. Fairbanks-Morse Co., Ltd., Montreal.  
Kales Stamping Co., Detroit, Mich.  
Kinzinger Bruce Co., Niagara Falls, Ont.  
Machine and Stamping Co., Ltd., Toronto  
The Greb Co., Boston.  
Casco Mfg. Co., Thomasville, Ga., U.S.A.  
Rothwell's Auto Specialties.  
Robinson, Edward A., Co., Ltd., Montreal.

## AUTOMOBILE CHAINS

Can. Fairbanks-Morse Co., Ltd., Montreal.

## BARN EQUIPMENT

Beatty Bros., Ltd., Fergus, Ont.

## BEAN MACHINERY

John Deere Mfg. Co., Welland, Ont.

## BEEF MACHINERY

International Harvester Co. of Canada, Ltd.  
John Deere Mfg. Co., Welland, Ont.

## BINDERS

The Frost & Wood Co., Ltd., Smiths Falls, Ont.  
International Harvester Co., Ltd., Hamilton, Ont.  
Massey-Harris Co., Toronto.

## BELTING

The Renfrew Machinery Co., Ltd., Renfrew, Ont.

## BATTERIES

Can. Fairbanks-Morse Co., Ltd., Montreal.  
The Renfrew Machinery Co., Ltd., Renfrew, Ont.

## CARRIAGES

Cockshutt Plow Co., Brantford, Ont.

## CREAM SEPARATORS

De Laval Co., Ltd., Peterboro, Ont.  
International Harvester Co. of Canada, Ltd.  
King Separator Co., Bridgeburg, Ont.  
Massey-Harris Co., Toronto.  
R. A. Lister Co., (Canada) Ltd., Toronto.  
The Renfrew Machinery Co., Ltd., Renfrew, Ont.  
Sharples Separator Co., Toronto.  
Swedish Separators Co., Montreal.

## CEMENT MIXERS

Can. Fairbanks-Morse, Ltd., Montreal.

## CASTINGS

Joliette Steel Co., Joliette, P.Q.

## CORN HARVESTERS

Cockshutt Plow Co., Brantford, Ont.  
International Harvester Co. of Canada, Ltd.  
Massey-Harris Co., Toronto.

## CORN MACHINERY

International Harvester Co. of Canada, Ltd.  
John Deere Mfg. Co., Welland, Ont.

## CULTIVATORS

Cockshutt Plow Co., Brantford, Ont.  
John Deere Mfg. Co., Welland, Ont.  
Massey-Harris Co., Toronto.  
The Frost & Wood Co., Ltd., Smiths Falls, Ont.  
International Harvester Co., Ltd., Hamilton, Ont.

## CUTTERS

Butterfield & Co., Inc., Rock Island, Que.

## DAIRY SUPPLIES

International Harvester Co., Ltd., Hamilton, Ont.  
R. A. Lister Co., (Canada) Ltd., Toronto.

## DIES

Butterfield & Co., Inc., Rock Island, Que.

## DISCS

Massey-Harris Co., Toronto.

## DITCHING MACHINES

Can. Fairbanks-Morse Co., Ltd., Montreal.

## DRILLS

Massey-Harris Co., Toronto.

## DRILLS, TWIST

Butterfield & Co., Ltd., Rock Island, Que.

## DRILLS, GRAIN

Cockshutt Plow Co., Brantford, Ont.  
International Harvester Co. of Canada, Ltd.  
John Deere Mfg. Co., Welland, Ont.  
The Frost & Wood Co., Ltd., Smiths Falls, Ont.  
Peter Hamilton Co., Ltd., Peterborough, Ont.

## ENGINES

Can. Fairbanks-Morse Co., Ltd., Montreal.  
Gilson Mfg. Co., Ltd., Guelph, Ont.  
International Harvester Co., Ltd., Hamilton, Ont.  
John Deere Mfg. Co., Welland, Ont.  
London Gas Power Co., London, Ont.  
Massey-Harris Co., Toronto.  
R. A. Lister Co., (Canada) Ltd., Toronto.  
The Renfrew Machinery Co., Ltd., Renfrew, Ont.  
Fisher, Wilkie, Ltd., Sandwich, Ont.  
Sharples Separator Co., Toronto.

## ENSILAGE CUTTERS

Can. Fairbanks-Morse Co., Ltd., Montreal.  
International Harvester Co. of Canada, Ltd.  
Massey-Harris Co., Toronto.  
Matthew Moody & Sons Co., Terrebonne, P.Q.  
The Renfrew Machinery Co., Ltd., Renfrew, Ont.

## FEEDERS

John Deere Mfg. Co., Welland, Ont.

## FARM MACHINERY

Can. Fairbanks-Morse Co., Ltd., Montreal.  
Cockshutt Plow Co., Brantford.  
Fisher, Wilkie, Ltd., Sandwich, Ont.  
John Deere Mfg. Co., Welland, Ont.  
International Harvester Co., Ltd., Hamilton, Ont.  
London Gas Power Co., London, Ont.  
Massey-Harris Co., Toronto.  
Matthew Moody & Sons Co., Terrebonne, P.Q.  
The Frost & Wood Co., Ltd., Smiths Falls, Ont.  
R. A. Lister Co., (Canada) Ltd., Toronto.  
The Renfrew Machinery Co., Ltd., Renfrew, Ont.

## FEED CUTTERS

Can. Fairbanks-Morse Co., Ltd., Montreal.  
Massey-Harris Co., Toronto.  
Renfrew Machinery Co., Ltd., Renfrew, Ont.

## FINANCIAL

The Commercial Credit Co. of Canada, Ltd., Toronto.

## GARDEN TOOLS

Massey-Harris Co., Toronto.

## GRAIN GRADER

Cedar Rapids Foundry & Machine Co., Cedar Rapids, Iowa.

## GRINDSTONES

S. Vessot & Co., Joliette, P.Q.

## GRINDERS

Can. Fairbanks-Morse Co., Ltd., Montreal.  
International Harvester Co., Ltd., Hamilton, Ont.  
Massey-Harris Co., Toronto.  
R. A. Lister Co., (Canada) Ltd., Toronto.  
The Renfrew Machinery Co., Ltd., Renfrew, Ont.  
S. Vessot & Co., Joliette, P.Q.

## HARROWS

Cockshutt Plow Co., Brantford, Ont.  
International Harvester Co. of Canada, Ltd.  
John Deere Mfg. Co., Welland, Ont.  
Massey-Harris Co., Toronto.  
The Frost & Wood Co., Ltd., Smiths Falls, Ont.  
The Matthew Moody & Sons Co., Terrebonne, Que.

## HAY LOADERS

International Harvester Co. of Canada, Ltd.  
John Deere Mfg. Co., Welland, Ont.  
The Frost & Wood Co., Ltd., Smiths Falls, Ont.

## HARDWARE

Can. Fairbanks-Morse Co., Ltd., Montreal.  
Massey-Harris Co., Toronto.

## HAY RAKES

John Deere Mfg. Co., Welland, Ont.  
The Frost & Wood Co., Ltd., Smiths Falls, Ont.

## HAY CARRIERS

Beatty Bros., Ltd., Fergus, Ont.  
Massey-Harris Co., Toronto.

## HAY PRESSES

Birdsell Mfg. Co., Toronto  
International Harvester Co. of Canada, Ltd.

## HULLERS (Clover)

Birdsell Mfg. Co., Toronto

## LIGHTNING SYSTEMS

Can. Fairbanks-Morse Co., Ltd., Montreal.  
R. A. Lister Co., (Canada) Ltd., Toronto.

## LIME AND FERTILIZER SOWERS

John Deere Mfg. Co., Welland, Ont.

## MANURE CARRIERS

Beatty Bros., Ltd., Fergus, Ont.

## MANURE SPREADERS

Cockshutt Plow Co., Brantford, Ont.  
International Harvester Co., Ltd., Hamilton, Ont.  
John Deere Mfg. Co., Welland, Ont.  
Massey-Harris Co., Toronto.  
The Frost & Wood Co., Ltd., Smiths Falls, Ont.  
The Matthew Moody & Sons Co., Terrebonne, Que.

## MOWERS

Cockshutt Plow Co., Brantford, Ont.  
International Harvester Co. of Canada, Ltd.  
Massey-Harris Co., Toronto.  
The Frost & Wood Co., Ltd., Smiths Falls, Ont.

## MILKING MACHINES

R. A. Lister Co., (Canada) Ltd., Toronto.  
Sharples Separator Co., Toronto.

## MILLING CUTTERS

Butterfield & Co., Inc., Rock Island, Que.

## NUT LOCKS

Robinson, Ed. A., Co., Ltd., Montreal.

## OILS

The Renfrew Machinery Co., Ltd., Renfrew, Ont.

## PISTON RINGS

WedgeRite Piston Ring Co., Ltd., Montreal.

## PLOWS

Cockshutt Plow Co., Brantford, Ont.  
John Deere Mfg. Co., Welland, Ont.  
The Frost & Wood Co., Ltd., Smiths Falls, Ont.  
International Harvester Co., Ltd., Hamilton, Ont.  
Massey-Harris Co., Toronto.  
The Renfrew Machinery Co., Ltd., Renfrew, Ont.

## POWER MACHINERY

Can. Fairbanks-Morse Co., Ltd., Montreal.  
John Deere Mfg. Co., Welland, Ont.  
Massey-Harris Co., Toronto.  
International Harvester Co., Ltd., Hamilton, Ont.

## POTATO MACHINERY

John Deere Mfg. Co., Welland, Ont.  
Matthew Moody & Sons Co., Terrebonne, Que.  
Cockshutt Plow Co., Brantford, Ont.

## PULVERIZERS

Cockshutt Plow Co., Brantford, Ont.  
International Harvester Co. of Canada, Ltd.

## PULPERS

Cockshutt Plow Co., Brantford, Ont.

## RAKES

International Harvester Co. of Canada, Ltd.  
The Frost & Wood Co., Ltd., Smiths Falls, Ont.

## REAPERS

International Harvester Co. of Canada, Ltd.  
The Frost & Wood Co., Ltd., Smiths Falls, Ont.



# Butterfield

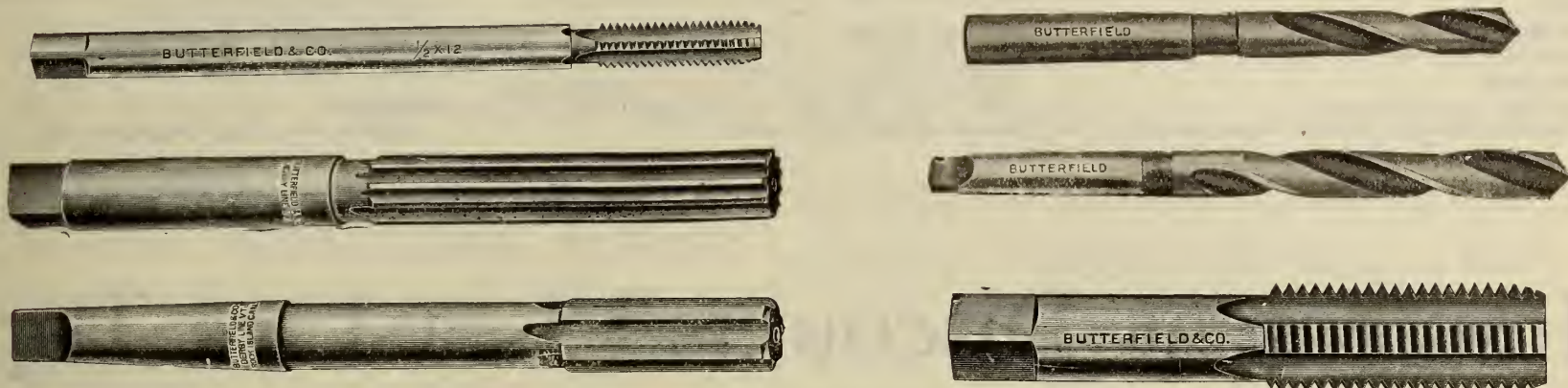

## Drills, Taps, Dies, Reamers and MILLING CUTTERS

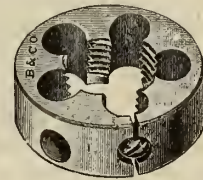
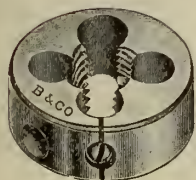

The quality of Butterfield Tools not only ensures accuracy, but long service and economy.

Try them and you soon will be convinced that they play an important part in keeping down the overhead in repairs.

The use of High Quality Tools on repair work is one of the es-

**Tools That Retain  
Their Keen Edges  
After Long Usage**

entials to the highest class job, and Butterfield Quality is the BEST.

Every nickel you save in tool service, adds another nickel to your profit on repair work.

May we send you our catalogue?

**BUTTERFIELD & CO., INC., ROCK ISLAND, P.Q.**

TORONTO OFFICE: 220 King St. W.



**REAMERS**

Butterfield & Co., Inc., Rock Island, Que.

**ROLLERS**

Cockshutt Plow Co., Brantford, Ont.  
Massey-Harris Co., Toronto.

**SAW MILL OUTFITS**

Massey-Harris Co., Toronto.  
Matthew Moody & Sons Co., Terrebonne, Que.

**SCUFFLERS**

Cockshutt Plow Co., Brantford, Ont.  
International Harvester Co. of Canada, Ltd.  
John Deere Mfg. Co., Welland, Ont.

**SEEDERS**

Massey-Harris Co., Toronto.

**SCREW PLATES**

Butterfield & Co., Inc., Rock Island, Que.

**STABLE EQUIPMENT**

Beatty Bros., Ltd., Fergus, Ont.

**SILOS**

Gilson Mfg. Co., Guelph, Ont.

**SLEIGHS**

Cockshutt Plow Co., Brantford, Ont.  
International Harvester Co. of Canada, Ltd.

**SILO FILLERS**

Gilson Mfg. Co., Guelph, Ont.  
International Harvester Co. of Canada, Ltd.

**SOCKET WRENCHES**

R. F. Sedgley, Inc., Philadelphia, Pa.

**SPREADERS, MANURE**

Cockshutt Plow Co., Brantford, Ont.  
John Deere Mfg. Co., Welland, Ont.  
International Harvester Co., Ltd., Hamilton, Ont.  
Massey-Harris Co., Toronto.

**SAFES**

J. & J. Taylor, Ltd., Toronto.

**SPARK PLUGS**

Machine and Stamping Co., Ltd., Toronto.

**TRACTORS**

Advance-Rumely Thresher Co., La Porte, Ind.  
R. A. Lister & Co. (Canada), Ltd., Toronto.  
Canadian Allis-Chalmers, Ltd., Toronto.  
Cleveland Tractor Co., Windsor, Ont.  
Gilson Mfg. Co., Guelph, Ont.  
International Harvester Co., Ltd., Hamilton, Ont.  
J. I. Case Co. Thresh'g Mach. Co., Inc., Racine, Wis.  
Massey-Harris Co., Toronto.  
The Gray Tractor Co. of Canada, Ltd., Winnipeg.  
The Turner Mfg. Co., Port Washington, Wis.

**TRACTOR PLOWS**

Cockshutt Plow Co., Brantford, Ont.  
International Harvester Co., Ltd., Hamilton, Ont.  
John Deere Mfg. Co., Ltd., Welland, Ont.  
Massey-Harris Co., Toronto.

**THRESHERS**

Can. Fairbanks-Morse Co., Ltd., Montreal.  
International Harvester Co. of Canada, Ltd.  
J. I. Case Threshing Mach. Co., Inc., Racine, Wis.  
R. A. Lister Co., Ltd., Toronto.  
Matthew Moody & Sons Co., Terrebonne, Que.  
The Renfrew Machinery Co., Ltd., Renfrew, Ont.

**THREAD CUTTING TAPS**

Butterfield & Co., Inc., Rock Island, Que.

**TWIST DRILLS**

Butterfield & Co., Inc., Rock Island, Que.

**TRUCKS**

Alberta Truck Transportation Co., Ltd., Calgary.  
Beaver Truck Builders, Limited, Hamilton, Ont.  
Eastern Canada Motor Truck Co., Ltd., Hull, P.Q.  
International Harvester Co. of Canada, Ltd.

**WHEELBARROWS**

Cockshutt Plow Co., Brantford, Ont.  
Massey-Harris Co., Toronto.

**WAGONS**

Cockshutt Plow Co., Brantford, Ont.  
International Harvester Co., Ltd., Hamilton, Ont.  
Massey-Harris Co., Toronto.

**WATER BOWLS**

Beatty Bros., Ltd., Fergus, Ont.

**WEEDERS**

Cockshutt Plow Co., Brantford, Ont.

# “Implement Discounts” Is a Live Topic

*Manufacturers Have Made Slight Increases, But Still More Urgently Required.*

**T**HE question of more adequate discounts to agricultural implement dealers is as vital a topic of discussion in the United States as in Canada, and the *Farm Implement News* is among those dealer-journals which has “fought the good fight” in behalf of dealers and agents. M. T. I. has agitated for this, and will always back any movement for betterment of conditions for the implement dealer. The *Farm Implement News* says editorially:

“Several dealers lately expressed the opinion that we are too optimistic over the settlement of the repair discount question as reported at the recent meetings of the dealers’ National Federation and the manufacturers’ organization. One dealer went so far as to say that we were too credulous. He said further, as did the others, that expectations as expressed in our editorials discussing the subject and implied in our news stories telling what had happened had not been realized to any considerable extent; in fact, that comparatively few of the manufacturers had increased the discounts on repairs in accordance with the spirit of the joint resolution adopted by committees from the dealers’ and manufacturers’ associations.

“**W**E were told also that in some cases manufacturers had made slight increases, and when asked why they were not allowing the amount of discount which dealers understood they were to receive, had replied to the effect that the resolution mentioned no amount. This is said to be the attitude of a number of manufacturers whose increased discounts are considerably less than the average discounts allowed before the joint resolution was passed.

“We have known of course from the beginning of the effort to get a recommendation for increased discounts from the manufacturers’ association that such recommendation would not be legally binding upon the members of the organization. No committee of an association can enter into an arrangement with another committee whereby the factors in one branch of the trade will be guaranteed that the factors in another branch will do thus and so. The committees can do no more than recommend; it is then optional with the members whether they shall comply.

“But we felt that this particular question, having been under discussion so long, was the subject of a recommendation which the members of the manufacturers’ committee were sure would be approved by the other members of the association. We felt that the personnel of the committee was such that its recommendations would have great weight, if indeed the committee had not canvassed the membership and

ascertained the views of the majority. The faith was also justified by the fact that a few of the large concerns already had increased discounts to meet the views of the dealers, had done this in some cases before the committees from the two associations held their conference, and in others before the proceedings of the conference had been made public. One was warranted in believing that this recognition of the dealers’ contention involving increased discount indicated a general adoption of the same policy, especially after a committee of leading manufacturers had publicly recommended such action.

“**T**HE weak point in the whole proceeding, from the dealers’ point of view, is that no rate of discount was mentioned in the resolution. But a rate was frequently mentioned by the members of the dealers’ committee in their pleas offered at the conference. The largest producer of farm equipment already had increased discounts to 35 per cent., with an additional percentage for cash, and one of the largest tillage concerns had adopted the same discount in its home office territory. This rate of discount was frequently put forward as the one dealers required; in fact, it was claimed by the members of the dealers’ committee that anything less would be inadequate. And the resolution stated in so many words that ‘the dealer’s cost of handling repairs makes the present average discount inadequate,’ and that ‘members should immediately analyze their conditions and institute such new plan as will be fair to the dealer.’

“Now, if the average rate of discount at the time the conference was held was inadequate, certainly a rate that does not exceed that average to some extent is still inadequate, and a manufacturer belonging to the association who refuses to allow a rate better than the old average, by such refusal repudiates the action of his own committee. And at this point it is pertinent to say that every member of the association who was present at the convention when Executive Chairman Wallis reported the action of the conference on repair discounts, and who did not then and there publicly protest against the action, is morally bound to follow the recommendation of the committee. The same obligation extends to all members who were aware of the committee’s action and made no protest before the report submitted by Mr. Wallis was approved and accepted by vote of the convention.

“**W**E realize of course that the use of the term ‘average discount’ raises a question as to what the average was at the time the subject was threshed

out by the two committees. Nobody knows exactly; nobody has any way of ascertaining exactly. But it has long been the opinion of leading dealers who have given much thought to the question, and who have made careful surveys among the retail establishments, that the average is, or was, at least 25 per cent., and that it was inadequate; in other words, 25 per cent. was not sufficient margin to cover the cost of doing business at a fair profit. This contention of the dealers was accepted by the several concerns to which we have referred, and the increase to 35 per cent. in their rate of discount was the result.

“Moreover, the trade relations committee of the dealers’ Federation, the committee which represented the dealers’ interests at the conference, said in its report to the Federation:

“‘The conclusion of the conference was that list prices on small parts, in part, and wood parts were in many cases ridiculously high; that similar parts as priced by different concerns vary as much as 50 per cent.; and that nothing less than 35 per cent. discount will net an adequate return to the dealer.’

“**T**HIS of course was not the formal conclusion, for it was not put in the resolution, but apparently it was the individual opinion of the members of both committees. Had it not been, the trade relations committee would not have so reported to the dealers attending the Federation convention.

“Have we been too credulous? We think not. To be credulous means ‘to believe on slight evidence.’ This evidence we have set forth is far from slight; it is ample. Perhaps we have expected too much from the mere recommendation of a committee, but we expected no more than we were warranted in expecting in this particular case, all things considered. And we are still expecting.

“At the Federation meeting one member of the trade relations committee ‘cautioned the dealers not to expect a complete change immediately.’ Further along in the report of the convention we read: ‘Opinions were expressed that it would not be long until the rate of discount mentioned would prevail throughout the horse-drawn implement trade and in many cases in the power-farming machine trade.’ If this opinion is not verified within a reasonable time, we’ll say that trying to adjust such matters through means of association committees represents a sinful waste of time.”



# What Massey-Harris Service Means to the Local Agent

**S**ERVICE is what counts in the implement business, and it is Service that is the outstanding feature back of the name Massey-Harris.

A manufacturing Service equal to supplying the most improved implements, of the best quality materials and the highest grade of workmanship.

A Service that can furnish exact duplicates of any part of any machine bearing the name Massey-Harris, and with speedy dispatch by means of the many branches and warehouses placed at strategical points across the Dominion.

And, a corps of Field Experts at your Service.

Thus the Massey-Harris Agent is enabled to render a most efficient service to the farmer. You can demonstrate this service in these quiet winter days by reminding the farmer to order the repairs he will require for his old machines for the coming season. This will help the farmer and save you valuable time in the busy season.

## MASSEY-HARRIS CO., LIMITED

Head Office: - Toronto, Ont.

Branches at Montreal, Moncton, Winnipeg, Regina, Saskatoon, Swift Current, Yorkton, Calgary, Edmonton. Transfer Houses at Vancouver and Kamloops. Warehouses at many other points.





## Mr. Dealer,

The Beaver Agency is a big  
**Money Maker**

The Beaver Truck, which is the result of actual truck knowledge, based on approved engineering, is

### Canada's Lowest Hauling Cost

We can prove these statements by comparative demonstrations---by comparative values.

*Write for full details and Agency Proposition*

---It is built on sound engineering practice and built to endure.

---It is built by Canada's largest exclusive truck factory.

---It is built by men long experienced in the manufacture of motor-trucks and who know Canada's transportation problems.

---Part of the large saving in duty on American trucks is put into extra built-in value and the balance is deducted from the usual list price of the trucks.

# Beaver Trucks

*Manufactured in Canada by*

---

**Beaver Truck Builders, Limited, Hamilton, Ont.**

---



# CANADIAN MOTOR, TRACTOR AND IMPLEMENT TRADE JOURNAL

Published Monthly by THE MACLEAN PUBLISHING COMPANY, LIMITED, TORONTO

MONTREAL, Southam Bldg. WINNIPEG, 1103 Union Trust Bldg. VANCOUVER, 39 10th Ave. West. LONDON, ENG., 88 Fleet St., E.C. 4. NEW YORK, 1133 Broadway. BOSTON, 734 Old South Bldg. CHICAGO, 1401 Lytton Bldg

VOL. II, No. 3

TORONTO, MARCH, 1920

Subscription Price  
\$1.00 Per Year

## A Quick Sales Proposition

Put an Acme  
where your  
customers  
can examine  
it carefully.

It will sell it-  
self.

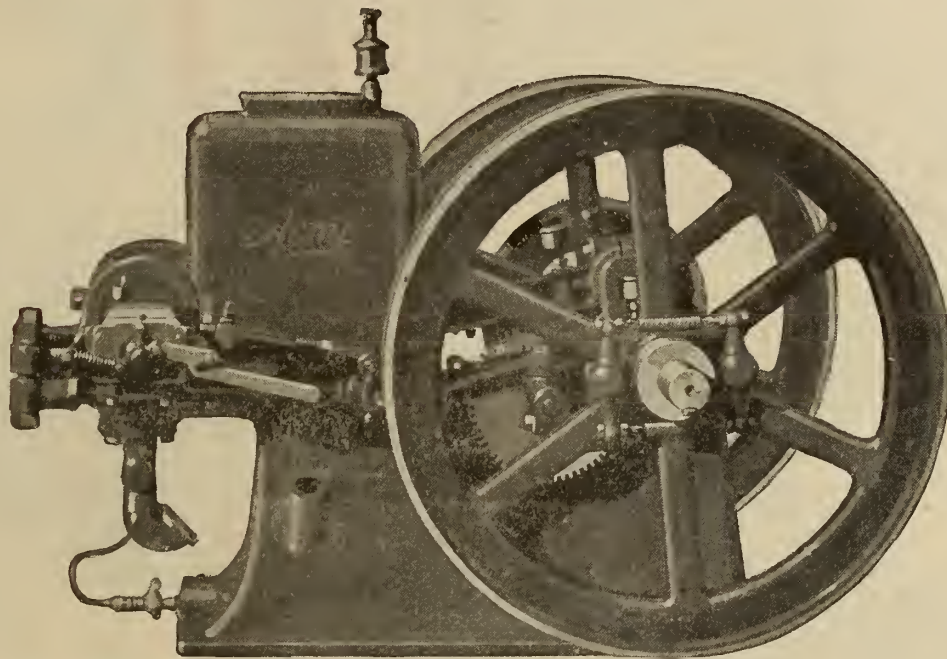

## Powerful Dependable Economical

The Acme  
develops  
power far  
in excess of  
its rating.

# “ACME” ENGINES

---1920 Series

Canadian-made machines of quality built in a full range of sizes between  $1\frac{3}{4}$  and 15 h.p. Manufactured by efficient quantity production methods which enable us to offer these machines at a price that makes them the best engine value on the market.

Acme reputation obtained through fourteen years' experience as builders of high-grade engines is jealously guarded by thorough, searching inspection of every part before it is allowed to leave the shops.

Some of the characteristic and exclusive features of the Acme line are:

Extra heavy and rugged design.

Perfect balance and smoothness of running, with absence of vibration.

All parts interchangeable and readily accessible.

Improved economy, excess power, and easier starting.

Special carburetor and improved magneto.

Every refinement of design or construction which ensures absolute dependability.

There are many other features which place the Acme alone in its class.

Demands on our 1920 output have forced us to extend our engine plant by 20,000 square feet, and to double the capacity of our engine castings foundry.

There are some territories still open—yours may be one.

**FISHER-WILKIE, LIMITED**  
SANDWICH, ONTARIO



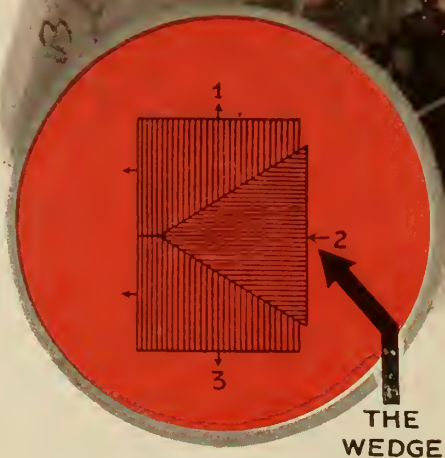

## The Secret of Its Permanence is in the Wedge

Many piston rings hermetically seal the combustion chamber—for a few days, a few weeks, or a few months. WedgeRite Piston Rings seal permanently. Of course there is a final limit to the efficient performance of any product, but WedgeRites are distinctly in a class of their own by lasting longer than any other rings made.

This is due to the application of the wedge principle, which automatically takes up wear and preserves an even pressure on all sides of the cylinder wall.

*Order through your favourite Jobber*

**Wedge Rite**  
PISTON RING  
COMPANY  
LIMITED

92 Notre Dame St. E., Montreal



CROSS SECTION OF RING

- 1—Section pressing outward and upward.
- 2—Spring section of ring.
- 3—Lower outward and downward section.

**ILLUSTRATING THE WEDGE PRINCIPLE**

The wedge principle employed in the making of WedgeRite Piston Rings is shown in the accompanying drawing. Its superiority, measured by its ability to expand in WIDTH as well as in diameter, means utmost satisfaction. The repairman who uses WedgeRite Rings is one who can be trusted. By using the Best Piston Ring he shows a real desire to give a better repair service.



# Lister

POWER ON THE FARM



The "Lister" Silo

## The high grade, dependable line of FARM AND DAIRY MACHINERY

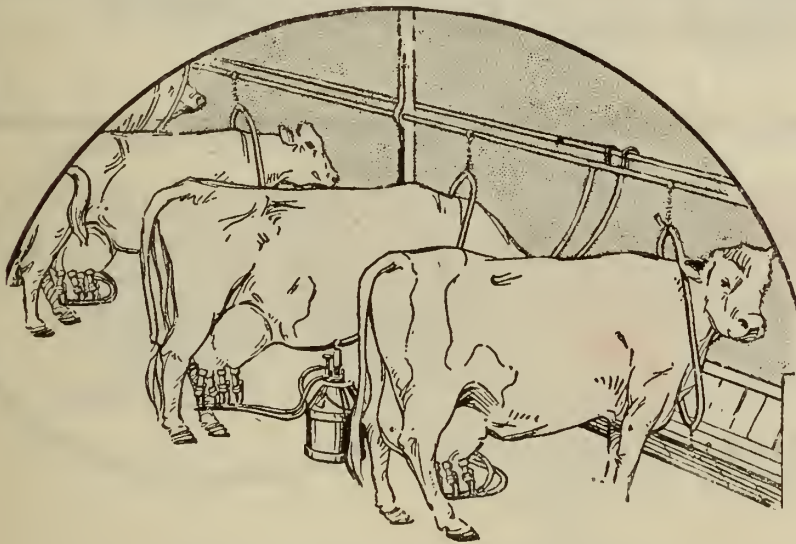

The "Lister" Milker

"A wonderful milker"—say users everywhere. Thousands in daily use. Can be used on all grades and breeds with entire safety.

### "Lister" Silos

The care used in the construction of the "Lister" Silo is equal to that employed in the other top-quality Lister lines. Every Lister Silo you sell ensures a satisfied customer.

The users of "LISTER" Machinery are our best advertisement. They are always boosting and the result is a good name everywhere that Farm and Dairy Machinery is used.

### "AVERY" TRACTORS

"Avery" Tractors are built in seven sizes—a size for every size farm—and sold at popular prices.

Lister products are business-builders and they pay a good commission. Write for agency proposition.

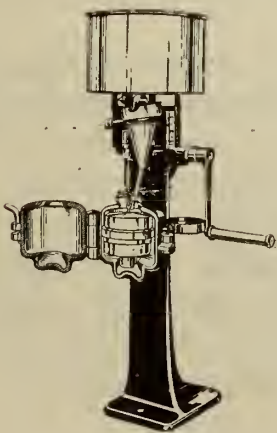

The "Melotte" Cream Separator

The Original Melotte—a marvel in skimming efficiency, ease of operation and long life.

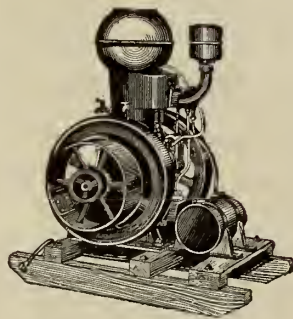

The "Lister" Engine

A leader in efficiency, workmanship and equipment. Compare the "Lister" with any of its competitors and its superiority will at once be obvious to you.

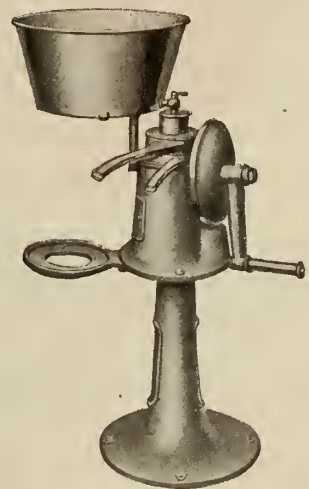

The "Premier" Cream Separator

British made—and its service shows it. Easy to operate. Easy to clean.

**R. A. LISTER & CO. (CANADA) LIMITED**

58-60 Stewart Street, TORONTO

Also at Wall Street, WINNIPEG





# Cletrac

## TANK-TYPE TRACTOR

**Added Power — No Increase in Weight  
Wider Tracks — Lighter Tread — Stronger Ground Grip**

*More kinds  
of Work  
More days in  
the year*

## Line Up For Progress

**C**ATCH on to the Cletrac idea. A Cletrac means *more kinds of work more days in the year* and lower costs on every job.

Engineers and army experts long ago saw the advantage of the endless track as a device for turning motor power into draw-bar pull. The popularity of the Cletrac is not an accident. The public waited only to see the same principle built into a serviceable small tractor and the Cletrac proved to be that tractor. Farmers everywhere put their O.K. on the small *tank type* and now the Cletrac is the fashion.

The Cletrac used alone or in "fleets" is the right

size and type for almost any farm—the one tractor adapted to all conditions. It has proved its ability to stand up to its work—and now that the public has realized its worth it is out in front to stay.

The Cletrac now has more power yet no added weight or increased friction to use up the power. Its track is one-third wider which gives it a lighter tread and a stronger grip on the ground. Read up on Cletrac literature and you will find dozens of other points that will help you to Cletrac sales—that will convince you that the Cletrac is the profitable way, both for yourself and your tractor customers.

*You are lining up with progress and prosperity when you push Cletrac sales. You can't go wrong on it.*

## The Cleveland Tractor Company of Canada Limited

Head Office:  
WINDSOR, ONTARIO

Western Sales Branch:  
REGINA, SASK.



# YOU'VE HEARD OF THE NISCO? SURE!

It's the **BIGGEST SELLING SPREADER** in the **WORLD!**

## WHY?

Because it is in a class by itself in performance and exceptional service.

It's the biggest money-maker for the farmer—the agent—and the implement dealer who sells it.

Isn't this a cracking good line for you to get next to?

**THERE IS BIG MONEY IN IT FOR YOU**



Indications show that this year will be a record-breaker for Spreader sales.

Spreader profits are generous—Here's the chance for you.

You want the Spreader that will bring the most money into your pocket. Isn't that so?

Gilson Nisco Spreaders are making thousands of dollars for other dealers. Why not you?

They are easy sellers because they dominate in service, quality and satisfaction.

The Gilson Nisco is the accepted standard of Spreader value.

Here are a few outstanding points:—

The original wide spread  
Improved feed  
Low draught  
**BIG DEMAND**

No complicated parts  
No gears  
Thoroughly standardized  
**NO EXPENSIVE REPAIRS**

They advertise themselves—one in your locality will bring many sales. You will make the profit on them all. The Gilson Nisco is in the public eye. You will pocket the cash. It's no trick to sell a Gilson Nisco.

Our entire organization is behind you. At the present time we are spending thousands of dollars on the biggest advertising campaign ever carried out for Spreaders in Canada.

Let's get together. It's a chance you can't afford to pass up. Do not fail to write us regarding our agent's proposition.

Better still, send in for sample Spreader. We are making a specially low price on all machines for demonstrating purposes.

**ANSWER THIS ADVERTISEMENT IMMEDIATELY**

## GILSON MFG. CO., LTD.

Factory and Head Office, Dept. E, Guelph, Ont.  
Branch and Warehouse, 356 Elgin Ave., Winnipeg, Man.

Without any obligation on my part you may send me your agent's proposition on:—  
(Put an X opposite the product that interests you)

Silo  
 Silo Filler  
 Engine  
 Thresher  
 Manure Spreader  
 Tractor

**FILL IN AND RETURN TO-DAY  
TEAR OFF HERE**

Name .....  
Post Office .....  
R.R. No. ....  
Remarks .....  
Prov. ....



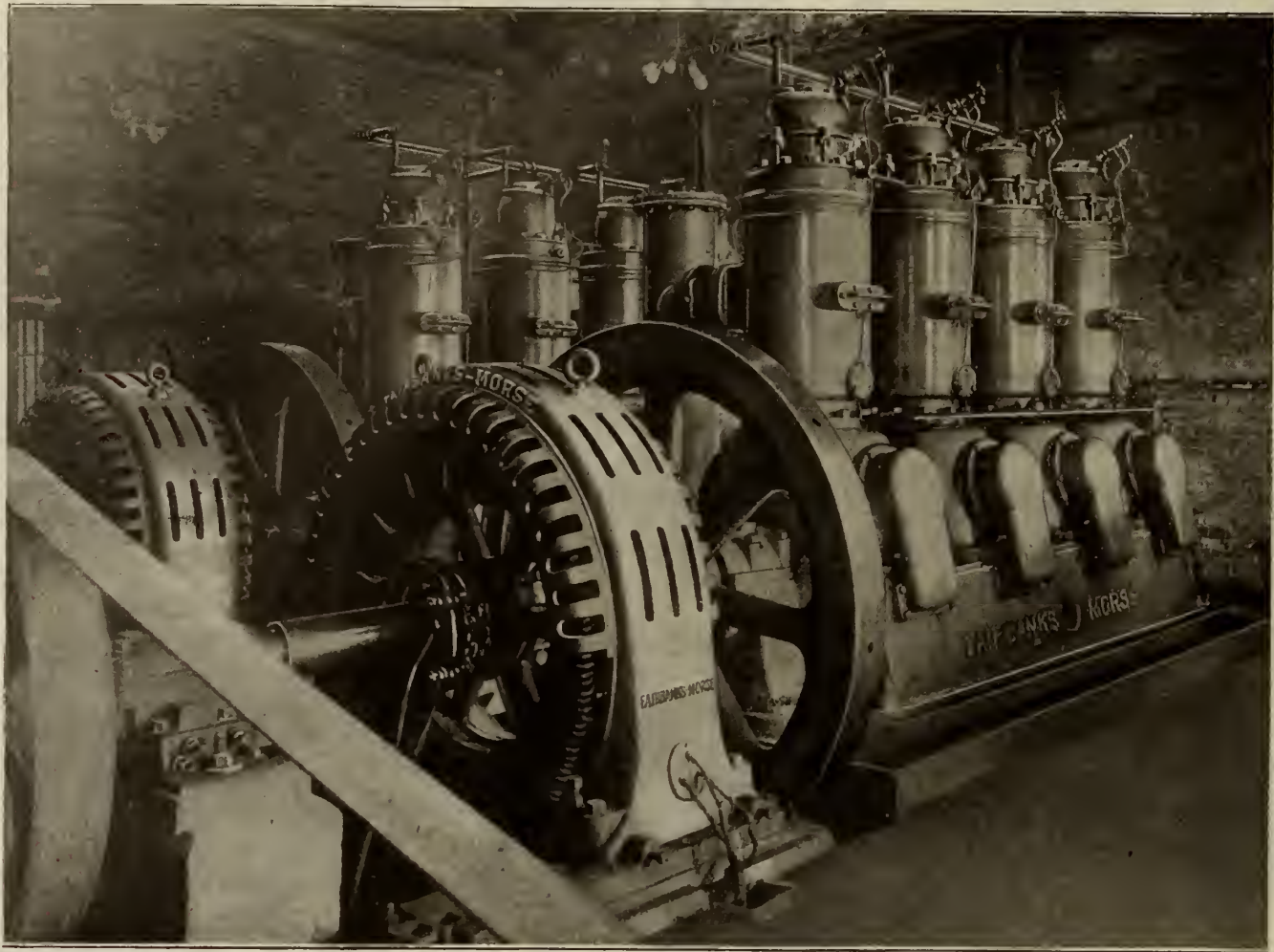

# FAIRBANKS-MORSE

## ELECTRIC POWER MACHINERY

Each of the units shown above consists of a 200 H.P. Semi-Diesel Oil Engine and a 170 K.V.A. Generator.

Our smallest plant is a 1½ H.P. 9 K.W. Automatic Suburban Lighting Outfit.

Fairbanks-Morse Electrical Machinery covers the entire range between the above sizes.

Our experience is at your service.

### The Canadian Fairbanks-Morse Co., Limited

*"Canada's Departmental House for Mechanical Goods"*



ST. JOHN	QUEBEC	MONTREAL	OTTAWA	TORONTO	HAMILTON
	WINDSOR	WINNIPEG	SASKATOON	CALGARY	
		VANCOUVER	VICTORIA		





## The Sales Possibilities for Power and Light Plants, and Necessary Equipment

**T**HE hour is ripe for the farmer market. The tremendous buying power of the farmer and rural dweller is waiting for aggressive men to develop.

As far as farm lighting and power plant sales are concerned, the market has hardly been touched. The automobile demonstrates what can be done, and what kind of a buyer the farmer is.

In two decades, automobile sales in Canada have exceeded \$450,000,000. How much has the farmer contributed to these enormous figures? In Ontario 65,000 cars are owned outside of cities; in Quebec and the Maritime Provinces 60% are owned outside of cities, and in the Prairie Provinces nearly 80% are owned by the rural population.

The market for power and light plants in rural districts is potentially as great as the number of automobiles now owned in those districts. Like the automobile, the power and light plant is a necessity to the farmer and rural dweller, because it means greater comfort, convenience and economy, and labor saving. The shortage of farm labor has forced the farmer to depend more and more upon labor saving equipment.

That the farmer needs power and electric light plants is evident by the growth of hydro service in those parts of the country which are served by the great transmission lines. Thousands of inquiries for hydro service

have been made in Ontario, the greater portion of which cannot be supplied.

In the Prairie Provinces over 11,000 self-contained electric light plants have been sold. In Ontario 2,130 plants have been installed, of which number 25% have been sold during the last twelve months alone.

These rural dwellers have learned that better equipment produces better returns.

Great as is the profit to be made from the sale of "F" Power and Light Plants, still more money will be made from their installation and the sale of equipment, such as electric washing machines, churns, vacuum cleaners, irons, cream separators, water pumps and water systems, which will more than double the sales possibilities of the plants themselves.

The sale of Fairbanks-Morse "F" Power and Light Plants will run into millions of dollars for those men who are awake to the possibilities of this business.

### AGENTS WANTED

Exclusive territories for this agency are now being allotted. If you want to make money, and make it faster than you have ever made it before, send the Dealer's coupon inside this insert, with your letter-head, to our nearest branch, asking that your territory be reserved for you.



## The Canadian Fairbanks-Morse Co., Limited

HALIFAX

ST. JOHN  
WINDSORQUEBEC  
WINNIPEGMONTREAL  
SASKATOONOTTAWA  
REGINATORONTO  
CALGARY

HAMILTON

VANCOUVER

VICTORIA



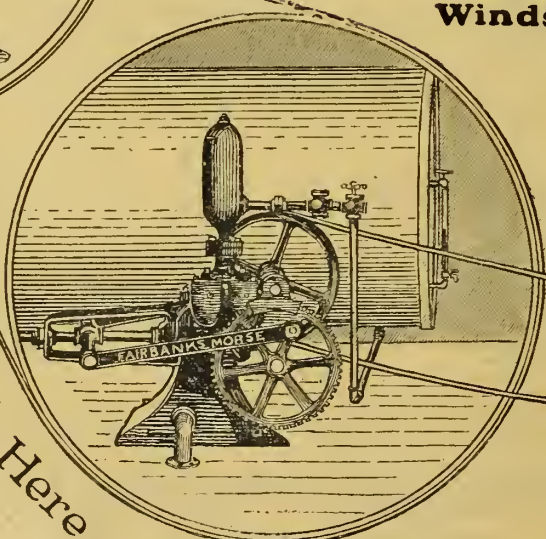
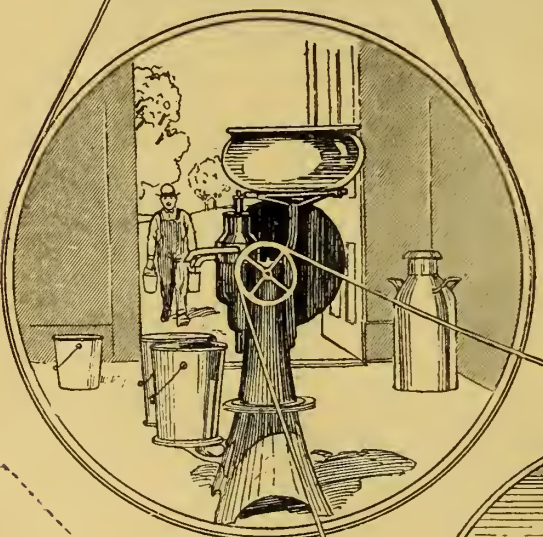
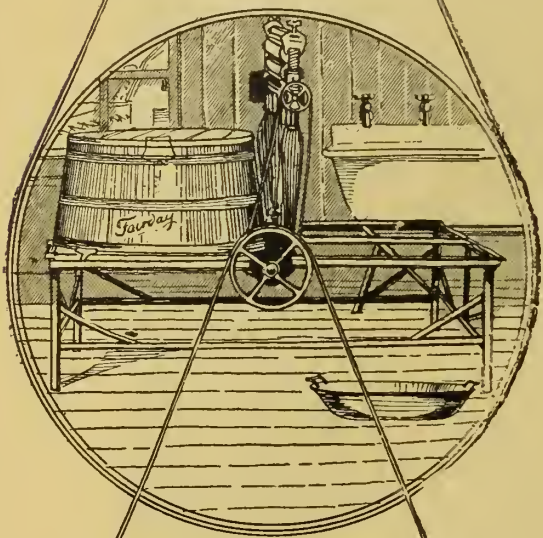
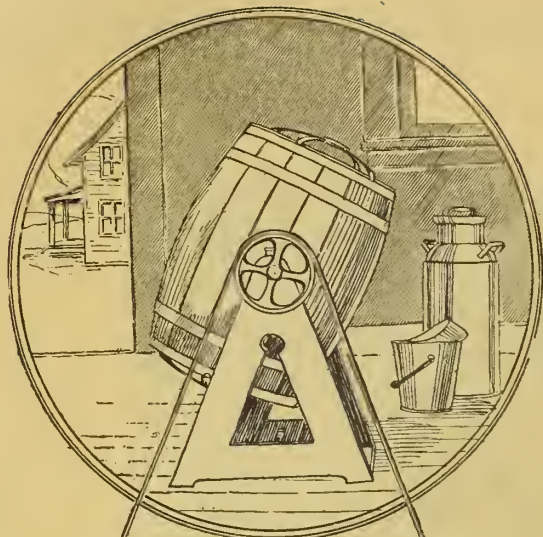

# If You Want Greater Comfort Install a Fairbanks "F" Power and Light Plant

**I**N a short time you will find that this plant is the biggest thing on your farm. Big in value, in comparison with the purchase price—big in the amount of drudgery it saves you—big in its labor-saving for your wife—big in its convenience—big in its comfort—big in its economy.

It is a separate unit plant, driven by the famous "Z" Engine, which more than 250,000 farmers are using. It permits of the greatest possible saving in power, because you can utilize the full power of the engine to drive other machinery by simply unbelting the generator and driving direct from the engine, thereby saving the 50% power loss caused by driving machinery with motors.

And you can, if you wish, drive another machine while you are charging your batteries.

It is so simple that any boy can run it. There are no costly,

**Agents**

We need good live agents in every section. Clip coupon on the left corner and send it, for full particulars of the biggest and best.

## The Canadian Fairbanks-Morse

- Montreal
- St. John
- Toronto
- Windsor
- Quebec
- Ottawa
- Hamilton
- Winnipeg
- Regina
- Saskatoon
- Calgary
- Vancouver
- Victoria

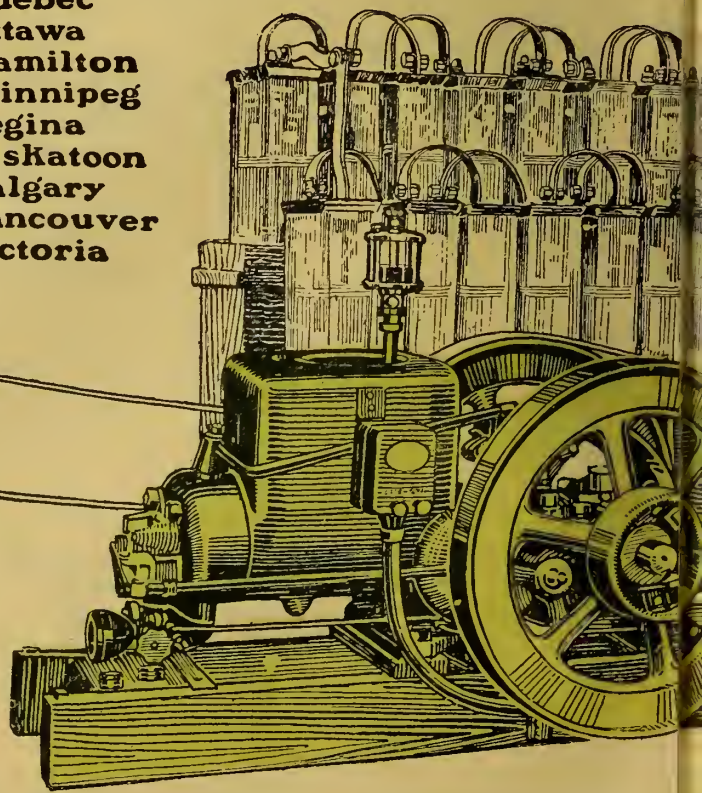

**Clip Coupon Here**  
**DEALER'S COUPON**  
 Fill in this coupon and enclose it with your letter-head and mail to our nearest branch for full particulars of Fairbanks-Morse "F" Power and Light Plant Agency.  
 Name.....  
 Address.....



# Efficiency, and Economy, Fairbanks-Morse Power and Light Plant

delicate parts to get out of order, and it requires little attention and seldom needs adjustment or repairs.

It is strong, sturdy and the most efficient Power and Light Plant made. It has ample power to drive a churn, separator, pump, washing machine, etc., direct from the engine or from a line shaft, and it will furnish a flood of clean, brilliant light in your house and other buildings, whenever you push the button. It also furnishes current for vacuum cleaner, electric iron, toaster, coffee percolator, etc., and there are no smelly lamps to fill and clean, and no danger of fire.

Thousands of farmers and rural residents will soon be equipped with a "F" Power and Light Plant, because it saves labor, time, worry and enough money to pay for itself. Clip the coupon on the right corner and send it to our nearest branch for full information. It places you under no obligation.

## Wanted

every city and district in Canada. Clip the coupon on your letterhead, to our nearest office for the best selling proposition on the market.

# Fairbanks-Morse Co.

Limited

## 40-LIGHT PLANT

### \$495.00 F.O.B.

### Toronto

Also made in  
65, 100 and  
200-light sizes

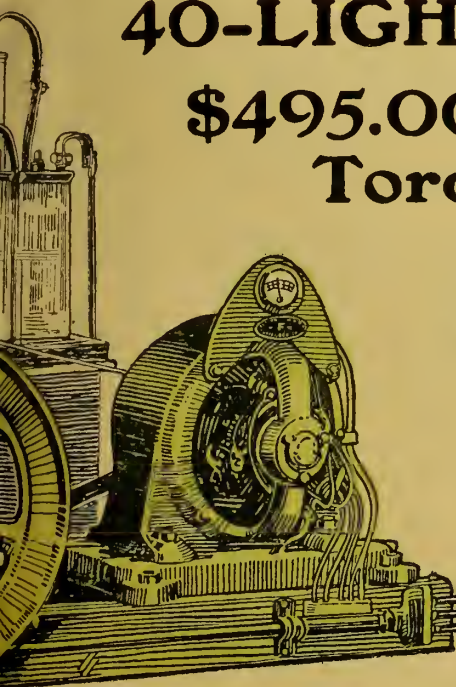

Clip Coupon Here

USER'S COUPON  
Canadian Fairbanks-Morse Co. Limited  
Tell me, without obligation, the advantages  
of Fairbanks-Morse Power and Light  
Plant.

Name

Address



# OPPORTUNITY

## The Greatest Money-making Agency in Canada



Wherever there is an oil lamp on a farm there is an opportunity for a lighting plant sale.

WE want at once, aggressive representatives in every section of Canada to handle the "F" Power & Light Plant Agency. The market for farm lighting and power plants is second only to the automobile field—we know that to be true because we have made a thorough investigation of the rural market in every province.

To supply the number of plants which can be sold *now*, were every district in the country in the hands of aggressive agents, would take the Fairbanks-Morse factories several years, running day and night.

The Fairbanks-Morse "F" Power and Light Plant fills the requirements of this immense market. We know it to be the lowest-priced plant made—we know it is the most flexible and economical in operation, and we know it is the most efficient plant ever constructed.

Behind this superior equipment stands The Canadian Fairbanks-Morse Co., Limited, with an intensive plan of co-operation, through which you cannot help selling the "F" Power and Light Plant.

### THE DOMINATING ADVERTISING CAMPAIGN FOR 1920

will blanket practically every prospective buyer of a farm lighting system in Canada, and every inquiry which it produces will be turned over at once to our agencies to follow up for sales.

The representatives selected to fit into this organization, to cash-in on such a tremendous money-making proposition as the selling and installation of our "F" Power and Light Plant, must have known responsibility and be willing to work the territory as it has never been worked before.

Each agent must make it his business to see that every plant is properly installed, and he must be able to render service to those to whom he sells. He need not be a practical electrician himself, but he should be able to hire one, or form a working connection with one already established.

He must invest in a plant for demonstration purposes, for we know *this is the one successful way* to sell lighting plants. People insist on being shown before they buy.

He must realize the great possibilities each installation offers for selling other electrical equipment; he must be capable of handling a business which will make his bank account grow by thousands of dollars each year.

If you mean business, fill in the Dealer's coupon inside this insert now, with your letter-head, and send it to our Branch nearest you.



The Canadian Fairbanks-Morse Co., Limited

HALIFAX

ST. JOHN  
WINDSOR

QUEBEC  
WINNIPEG

MONTREAL  
SASKATOON

OTTAWA  
REGINA

TORONTO  
CALGARY

HAMILTON

VANCOUVER

VICTORIA



# CANADIAN MOTOR, TRACTOR AND IMPLEMENT TRADE JOURNAL

Volume 2

TORONTO, MARCH 5, 1920

Number 3

## THE COMPANY AND THE DEALER

*Co-operation Necessary to Success—Team Work Wins the Game*

By G. B. WHEELER

THE successful dealer in the company's experience is not the one who is constantly asking for special assistance, but is the man who takes full advantage of the opportunity, listens to the sales arguments of the special salesmen and soon is able to present his machine or proposition far more convincingly than any special man, because he knows personally the man to whom he is endeavoring to make a sale. The dealer who knows his line will secure the order while the dealer who does not know his line is sitting in his office waiting for special salesmen to arrive. Many a dealer has lost a beautiful order in just such a manner. To be successful a dealer must stand on his own feet, and use the special salesmen only as an instructor while getting the necessary information.

We are convinced that there is no more profitable way for a dealer to spend a part of his time, than in a few hours extra educational work when he first delivers a machine to a customer. Did you ever notice how confidence breeds enthusiasm? The customer who knows his machine thoroughly has confidence in it and is always a great booster for it, and for the dealer who imparted the information to him.

The company is doing its utmost to assist the dealer. They believe that through the dealer is the proper method of marketing goods, but realize they can only be successful in any one territory as their dealer in that particular territory is successful. They, therefore, maintain a staff of special salesmen to assist in particularly hard sales and to instruct the local dealer concerning the merits of the goods, company's methods of doing business, and best means of making sales and educating the customers.

A staff of special mechanics is maintained in order to assist the dealer out of any serious mechanical trouble and to educate them, so they in turn may be able to properly educate the customer.

The repair department is usually in the hands of men who realize the necessity of prompt and accurate filling of orders, but they are not mind readers, and must have the necessary information before an order can be filled accurately, and any dealer will tell us that a repair order filled incorrectly is worse than not filled at all.

None of us are celebrating any personal independence day. We are all interdependent. The salaried man depends on the company for his pay envelope; the local dealer on the company for his commission; the purchaser depends on the company for the goods; the company depends on the purchaser for payment, on the salaried man—whether salesman or mechanic—for such service as will make the goods appeal to the purchaser, and on the local dealer for the order.

The whole question of sales and service is summarized in co-operation. If the company isn't prepared to fully co-operate with its corps of local dealers, it should change its method of marketing goods, and if the dealer isn't prepared to fully co-operate with the firms he represents he should go out of business because he only cumbers the ground. Our experience proves, however, that when company and dealers have mutual confidence in each other and the goods they are manufacturing and selling, and co-operate with each other as they should, the business then is a pleasurable and profitable undertaking.

Every man placing his shoulder to the wheel, carrying his own share of the load, will make the way easier and the financial returns will be all they should be; the customers will think well of the people with whom they are doing business, and a good, clean, healthy business and business growth will be enjoyed by both the company and the dealer.

THERE is one more important point I would like to emphasize and that is the ordering of repair parts.

The dealer should be accurate in placing his orders for repair parts, furnishing shop number and type of machine and when possible symbol number of part.

The Repair Department staff has a thankless job at best, but are usually ambitious and sincere and can only ask for co-operation on the part of the dealer in order to give the service that holds the customers.

The inside sales organization is usually made up of men who might readily be termed a "ways and means committee." They are always puzzling and planning as to how to increase the sales volume, and dealers will admit that the company's staff is usually doing its best and while sometimes that best may seem none too good, yet TEAM WORK WILL WIN THE GAME. That applies to baseball, lacrosse, football or war, and is also more than true in business.

After all it don't make a lot of difference to the farmer whether it is a worm drive or a snake drive—just so she does the work.

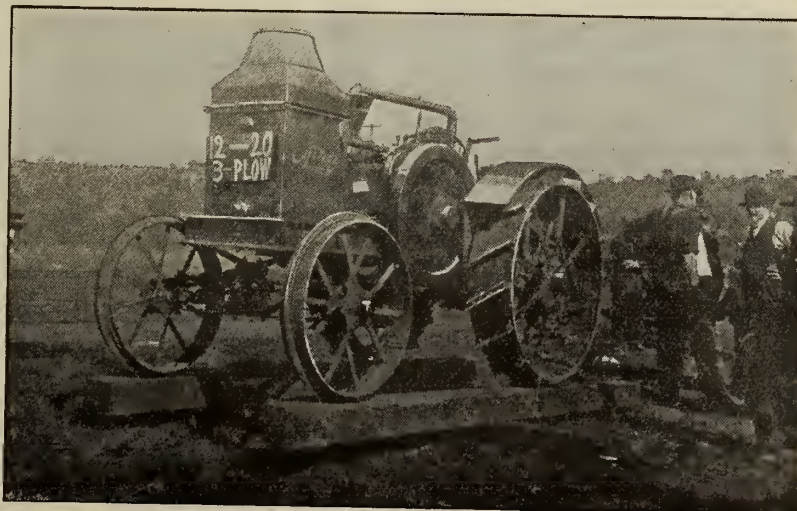

The 12-20 Oil Pull as displayed at a County Fair by an enterprising dealer. This tractor was run on skids balanced on a cross timber at a perfect balance and ran throughout the day to show absolute non-vibration. L. J. Stalbaum, Elkader, Iowa, dealer.

IN TALKING to a local dealer he will usually refer to the firm he is representing as "The Company" and it isn't always in complimentary terms that he discusses the subject. In our experience, however, we usually find that the successful dealer who has extensive dealings with the companies he represents is more than friendly and ready to co-operate, hence his success.

The dealer is on the firing line, in direct personal touch with the ultimate purchaser, and his success depends on:—

His integrity and reputation for fair and square dealing.

The quality of the goods he sells.

His energy in going after business.

The intelligent service rendered his customers.

Advantage he takes of assistance the companies he represents are prepared to render.

Every reliable concern is more than anxious to co-operate with its dealers and customers in getting best possible results from equipment marketed. Unfortunately some machines of almost all kinds, harvesting, tractors, automobiles, etc., have gone on the market in the experimental stage, and the experience of both dealers and customers has been both patience trying and financially costly. Some freak ideas of design seem to have a great appeal on paper, but in the field, on the point of actual work, they fall down miserably. There is an excuse for a consumer being "taken in" by these unsound ideas, but an experienced machinery dealer should have no trouble in avoiding them.

We are sure that the sales manager of any company marketing its products through a corps of local dealers will agree with us when we say that one of the hardest problems we have to solve is the overcoming of inertia in our dealers. It seems to require a stick of dynamite to wake some men up to the possibilities of business and profits that are at their very doors.

The successful dealers as they are viewed from the companies' point of view are not the men with most pretentious premises, etc., but are the men who are aware that when they contract to sell a line of goods in a given territory, realize that they have assumed a two-fold obligation, viz.:—

To themselves, to build up a profitable business and thus improve the condition of themselves and their families; and an obligation to the company to secure all the business possible from the territory assigned to them.

Such a dealer will have his place of business clean and orderly. If able to carry stock it will be in good condition and ready to make a sales appeal.

He will be familiar with the talking points of his machines, prices and terms on which they can be sold.

His staff will include a man—himself if no other available—who can teach the customer how properly to operate the machine he has purchased.



# Wake Up! Go Ahead! Implement Dealers

*Don't Shout Disaster From the Housetops—The Woods Are Full of Prospects Who Want What You Have to Sell*

**I**N MY opinion, every man's duty at this hour can be expressed in two words, 'GO AHEAD.'



That's what Thomas A. Edison said a few weeks after the armistice, when everyone seemed to be waiting for something to happen. They were afraid of this and talked collapse of that, and they waited, waited, WAITED—goodness knows what for. This policy

of indecision was fatal to a good many business enterprises, and Edison's advice was timely.

The waiting malady seems to have settled in epidemic form in a good many parts of Canada, and unless some dealers wake up and "GO AHEAD," they are likely to start going the other way, and won't be able to stop. What Mr. Scott said in the last issue of M. T. I. about truck dealers, which was the opinion of one of the largest distributors in the country, is applicable to many other dealers as well. They can't seem to grasp the situation that confronts them and somehow fail to realize what enormous sales opportunities are waiting right in front of their noses. They apparently have a sort of business sleeping-sickness. I don't think this applies to dealers in Alberta so much as in some other sections of the west, but there is apathy and indifference even in Alberta, a country noted for its optimism.



During the past two years we have had partial crop failures in Alberta, and naturally there was quite a falling off in business. And the dealers didn't pass up any opportunities to tell the world about it either. I had an interview with C. Haskins, vice-president of the International Harvester Company last August, and he vehemently deplored the general tendency on the part of dealers—and distributors and branch managers—to foist all the blame on the country when their sales fell down. He said that dealers' reports of conditions in Southern Alberta were woefully pessimistic and very much overdrawn. Those who foresaw abnormally low sales owing to crop conditions painted the blackest kind of a picture so the head office would thoroughly understand that it was not their fault. I know this to be a fact because I visited numerous head offices of implement companies in the United States last fall and their Alberta dealers had sure done the thing up brown. Many executives who didn't know conditions thought the country had gone to the everlasting "bow-wow."

This is just a point in passing, and I want to emphasize it if I may, because dealers who do this not only condemn their own territories, but they literally damn the whole country. Its pretty hard to say business is good when its rotten, but surely there's enough good things to talk about without shouting disaster from the housetops.

**PROSPECTS?** Every other man you meet is a prospect. For what? For motor trucks, tractors, automobiles, electric lighting plants, electrical appliances, building materials, gas engines, windmills, water systems, accessories, separators, scales, feed grinders, fanning mills, every kind of seasonable farm machinery, stable equipment, lightning protection,



ventilating systems, and every mortal or immortal thing YOU have to sell.

Take motor trucks. They won't need much selling in Alberta this year. Everybody wants trucks, not only the city buyer but the farmer. The Western farmer is absolutely sold on the truck idea. A big advertiser of tractor attachments for Ford cars

By C. McLENNAN

Sketches by LOUIS KEENE

carried a small line in six-point type at the bottom of his ad. which read: "we also distribute the—truck. If interested mark the coupon." Over fifty per cent. of the inquiries signified interest in trucks. The bulk of the replies came from Alberta.

In a recent investigation, a well-known Western farm paper brought out the following information on trucks among farmers:

	Reports Received	Number Using	Could Use
Manitoba .....	58	50	1,181
Saskatchewan .....	168	313	4,122
Alberta .....	106	630	6,301
	332	993	11,604

In this investigation which was conducted through branch bank managers, 141,436 farms were reported on.

Study these figures carefully and watch your territory closely. The "woods are full" of prospects who want what you have to sell and want it now.

Another farm paper showed through an investigation that there were approximately 10,000 truck prospects among its readers.

Is this conclusive enough?

Take tractors. I venture the assertion that 1920 will see the biggest volume of tractor sales that Canada has ever known. The farm paper mentioned discovered approximately 12,500 tractor prospects among its readers alone! It found 22,500 electric lighting plant prospects, and 65 per cent. of the farms covered indicated that they would erect some buildings this year.

The list included modern dwellings, bunkhouses, cow barns, horse stables, piggeries, granaries, etc. That means lumber, cement, hardware, lightning rods, water systems, plumbing, lighting equipment, stable equipment, etc., etc. The average size of farm covered was 487 acres, and 90 per cent. of the owners specified that they bought advertised goods in preference to non-advertised.

This was in Alberta, mind you, in the fall of 1919, when so many dealers were bewailing their fate and talking calamity.

Reports show a 437 per cent. increase in automobile registrations in Western Canada since 1914. In 1919 the gain over 1918 was 26 per cent.

In the year of our Lord 1919, in the face of so called crop failure, thresher licenses numbered more than 3,000, whereas in 1918 registrations were only 2,000.

The wheat yield in 1918 was 23,091,000 bushels valued at \$50,800,200. In 1919 it was 25,451,000 bushels valued at \$54,719,80. Total agricultural wealth of the province was \$477,803,711, an increase of \$31,205,350, over 1918.

In the driest of the dry belt, land sold last fall for \$100 an acre—for 640 acres, and all cash, too, \$64,000. The C.P.R. sold over a million dollars worth of irrigated land last spring.

Take Calgary as a gauge. It reflects pretty accurately conditions in the surrounding country, and it depends absolutely on agriculture for its prosperity. Collections were better last fall than ever before; profits were returned on all municipal utilities; bank clearings and deposits increased steadily during the year; building permits exceeded 1918 by over

\$1,000,000. And Calgary doubled its victory loan allotment, subscribing \$5,117,100.

I could pump optimism into this article endlessly. But these few remarks ought to inject a little pep where it is needed. I have dealt largely with Alberta because I know it best. But the majority of the statements apply broadly to all Canada.

The dealer who appreciates what is transpiring around him and who goes after the support of his distributor or factory, who insists on dominant advertising in mediums he recommends and who follows up his inquiries till they either "buy or die," will get the business. The ones who remain in their present state of lethargy will get left.

1920 is a year full of promise. As I said before, every other man you meet, Mr. Dealer, is a prospect who wants what you have to sell and wants it now. Get going early and be sure you



**"Go Ahead."**

## A TOWN TRACTORS AWAY

TRACTORS have been used for numerous purposes apart from regular farm work. Farmers are more and more recognizing their usefulness in heavy hauling. Contractors frequently use them for moving houses from place to place. Yet when every cottage and store in a town of 300 inhabitants is hitched to a tractor and pulled across country to a new site surely we have reached the limit. That is exactly what happened recently, in Texas.

The village of Ochiltree, disappointed in a long cherished ambition, when the new railroad cutting across its county passed it by and went instead through a smaller and rival town, decided, when the railroad would not come to the town, that they would take the town to the railroad. So procuring all the husky tractors available the indignant town moved over beside its sister settlement and thereby secured its much coveted place on the railroad map.

THE following letter was received recently at the Essex factory from J. Y. Cawagoe, Tokio, Japan.

"Dear, my dear: "Sweet home of the white triangle.

"I am happy to write to you that your babies in this land are also treading the joyful life.

"—And the Essex loiters along the country lane, where the Japanese iris smiles during an interval of the rainy season.

"Say flying rather than riding in it.

"It should be real comfort of motoring to drive an Essex."



If you are in love with your business and are putting all your heart into courting it, you won't even hear that designing spinster, Miss Pessimism, when she comes wailing her leap-year serenade



# TRUCK TRANSPORTATION

THE farmers' big problem to-day is how to get his commodities hauled to the market. With this problem solved the possibilities of increased crop production are materially strengthened.

Lack of efficient transportation between the farm and the city market is a most serious handicap to farm progress. The statement has been made after careful investigation that half of our perishable food-stuffs never reach the consumer. This is largely due to the weakness of our present transportation methods to meet the farmer's needs. 40 per cent to 60 per cent. of the total crop is wasted because of lack of means to haul it to the market.

To the farmer the waste through inefficient, expensive means of reaching the market works a tremendous loss in time, labor and material and robs him of his legitimate share of what he produces. The wastage, with its loss to the farmer, can be eliminated by proper transportation facilities from farm to market.

## Rapid Access to Market Necessary

The highways are the natural lines of communication between the rural districts and the centres of population. On them the farmer must depend for access to his markets. But increasing population and rising demand for food has made more rapid access to markets as necessary as enlarged productivity. Horses are not only inadequate but are more urgently needed on the field.

In this emergency the farmer naturally turned to the Motor Truck to solve this problem. Awake to its important advantages over horse-drawn vehicles and hampered by scarcity of man-labor he impressed the truck into use to bring his markets nearer, even before the manufacturer was fully alive to its great potential usefulness on the farm. By bringing the kitchen door of the consumer closer to the field, the farmer has greatly extended the market for his products.

So well has it solved the perplexing haulage problem that many farmers, truck gardeners and dairymen declare that without this improved means of transportation they would be obliged to seek a more profitable occupation.

## Rising Farm Values

The use of the truck for advanced efficiency on the farm follows the natural trend of progress. Increasing production has developed the necessity for time and labor-saving machinery that has gradually evolved from the cradle scythe of a hundred years ago to the tractor of to-day. In the same way the great need for the means of conveying the immense farm production of the present to the market has called for machinery to replace the horse.

With the ability of the farmer to cultivate more acres more intensively and bring his market closer, farm values have shown a vast increase. Under the old hand methods of farming, from 1850 to 1900, farm values in America increased from four billions to twenty billion dollars. In the regime of labor-saving machinery, from 1900 to the present day, farm values have shown a phenomenal rise from twenty billion to seventy-five billion dollars.

EVEN if horses could be spared for the important work of transportation, their use for the purpose is wasteful and inefficient, as compared to the advantages of truck service. This is convincingly shown by the results of an investigation made recently by the U.S. Bureau of Crop Estimates. The data, which is based on 898 country reports covering the year 1918, gives some interesting figures on the use of motor trucks in hauling from the farm to the market or shipping points.

According to these reports the average length of haul by motor truck was 11.3 miles, against that by team of 9 miles. On these hauls the truck made an average number of 3.4 round trips while the wagon made 1.2 round trips. The average truck load was 58 bushels of corn on the cob and 84 bushels of wheat, as compared with 39 bushels of corn and 56 bushels of wheat per wagon load.

This shows the superior advantages of the truck in the larger quantities that can be hauled per load and in the greater number of trips that can be made in a day.

By M. D. EAST

*Mr. M. D. East is President of the Alberta Truck Transportation Co., which is establishing a truck transportation system in Alberta. Mr. East will contribute an article in the near future on the organization of this company. The Co. handles five standard trucks—F. W. D., Garford, White, Mack and Master. Mr. East has organized several truck transportation companies in the U.S.*

A great field for usefulness of the truck on the dairy farm is demonstrated by a recent investigation. Of the milk produced in 70,000 dairies, 50 per cent. is hauled an average of 3½ miles to the creamery. One-half the farmers make this 7-mile trip every day, which makes an average yearly total of 2,555 miles for each dairyman. The average time for the round trip is 2½ hours. If the use of the motor truck shortened this time by only an hour the saving in a year in this industry alone would amount to substantial proportions.



Showing how Trucks may be used on bad roads.

## Overland Haulage

Overland motor truck haulage has developed into a permanent institution and is no longer an experiment or a new thing, to handle a certain percentage of the nation's goods. Its future development will depend upon the speed with which new and better highways are built and will follow closely the principles of railroad growth. The most successful concerns will operate large fleets of trucks and run them in much the same manner as railroad trains. These concerns will erect warehouses in the various terminal cities to which goods may be brought for the assembling of full loads, so that the overland trucks can operate with capacity loads from each direction.

Many of the failures of concerns entering into the overland haulage business have been due to unfamiliarity with the work and to the belief that business would be forthcoming without any serious effort on the part of the truck owners. Such concerns obtained sufficient work during the embargo period, but



Truck Transports Collecting Farm Produce.

these once over, they were at a loss as to how to instill the idea of motor transportation into the average shipper, so they failed.

## The Organization Policy That Will Hold

THE Transportation Company organizes all farmers, merchants, wholesalers, retailers, manufacturers and industrial concerns who want the use of the transportation system, and must become part of that great system, together with the employees of the organization, so that at any period of the year when hauling is light the Transportation System has only purchased enough equipment to take care of its own stockholders and its stockholders' business and amount of production over their own system, and in this way there is no danger of the Transportation Company going broke. Further, the Transportation Company secures the agency of the trucks which it operates, thus saving a profit of some 20 to 30 per cent. on the purchase price of trucks and all its equipment, which gives the company twelve months of operation without a depreciation, as their trucks are still worth at the end of one year what has been actually paid for them in cash; and the investor is absolutely secured on his investment. The profits that are made by the Transportation Company are then divided back among its stockholders, who are no other than the shippers.

It is true that if a truck driver has an interest in the truck or the equipment that he handles he is more efficient and takes far better care of the truck and goods in his charge and the company will not be tied up with a strike for the simple reason that its employees are stockholders and are getting paid equally with each and every stockholder by dividing their profits, and they also get a good salary and are able to live cheaper than any other employees at truck work for the reason that they are permitted to haul their products from the farm and only pay the Transportation Company the hauling charge.

A truck transportation company can operate cheaper than an individual truck owner or the average concern as in most cases transportation companies are distributors of the trucks in the district or territory in which they operate and will save the dealer's or middleman's profit otherwise made. They are also able to buy tires, oils, greases and repair parts at a greatly reduced price over that of any individual operator and operate with 100 per cent. efficient driver against the average individual who cannot afford to pay a first class driver or who probably has no means of proving whether the driver is first class or not.

## WHOLESALE EXCLUSIVELY

AN important announcement has been made by John Millen and Son, Ltd., automotive equipment jobbers, that after February 29 they would discontinue retail sales and devote all their energies to a wholesale business exclusively. This change in policy has been brought about by the expansion of the automotive equipment business, and is in accord with the policy of the Automotive Equipment Association.

It is no longer necessary to refer the car owner to the wholesale warehouse in order to secure an adequate selection. The garageman and dealer today carries a comprehensive stock and is able to cater to the consumers' needs.

## BRITAIN SEES ADVANTAGE OF MOTOR TRUCKS

DURING the recent railroad strike in Britain hundreds of army motor trucks were put into freight and express service as an "emergency measure." The trucks did so well that they are to be used permanently for hauling small package freight for short distances. When the railroad strike began yards and warehouses were terribly congested and it was in order to relieve this congestion that the transportation authorities decided to use the truck. Many permanent rural lines have been established and before long it is expected that they will embrace the more thickly populated sections.



# Oldest Implement Business Has Newest Ideas

*Practical Demonstrations—Important Part of Sales Campaigns—  
Knowledge of Parts Essential*

**H**AVE you seen THE ARK?

The Ark is the name the farmers of Oxford County have given the implement store of John Fowell & Son, Woodstock, Ont.

"If you cannot get it at the Ark," the farmers say, "you cannot get it at any other place."

Edward C. Fowell is the proud head of this business, which, by the way, is one of the pioneer and at the same time one of the most progressive farm implement businesses in Canada. Forty-three years ago the business was started by his father, John Fowell, who when he died in the spring of 1919 in his eighty-second year, was about the oldest implement dealer in the whole of this broad Dominion.

It was in 1876 that John Fowell broke into the implement field, in the days of the wobble-gear mower, and old wooden-frame binder, which bound the sheaves with wire instead of cord, as used today. He was a true pioneer, and had the honor of introducing to the Canadian farmer several of the labor-saving machines he now enjoys. He was one of the first agents in Canada to handle the machinery of the Deering Harvester Company of Chicago—now the International Harvester Company—and the John Deere Plow Company of Moline, Ill., and for years had imported their machinery from the United States prior to their opening factories in Canada.

The business gradually grew under the direction of John Fowell until to-day it is one of the most extensive and progressive in Eastern Canada. Under the name of John Fowell & Son a wholesale and retail trade has been carried on. For years the firm has been

the wholesale distribution in Ontario for the Planet Junior garden tools, selling only to the dealers. They were also frequent exhibitors at the Canadian National Exhibition, Toronto, where, in 1910, they were granted a diploma for the excellence of their exhibit.

In the spring of 1919 Mr. John Fowell died, practically in harness, leaving a well-organized and healthy business to his son, Edward C. Fowell. Discussing with the M.T.I. the principal points which helped to build up such a fine business, Mr. Fowell said:

**"I**N THE first place, we handle nothing but the best goods manufactured by the best firms. That was my father's policy and it will continue to be mine as long as I sell farm implements. One of my father's favorite maxims and one which impressed me very forcibly was: 'The best is not too good and the price is no object.' He followed that up by saying: 'Superior goods will remain long after price is forgotten.' We have always offered the best to our customers and have no reason to regret doing so. In fact, our place has earned the reputation of being 'a safe place to deal.'

"We never knock the other fellow's goods, but try at all times to show the superior qualities of the machines we handle. A knocker sooner or later gets into trouble and loses the confidence of his customers.

"We study our machines so that we can talk intelligently about them and can answer any question likely to be asked by our prospects. *How can a man successfully handle a line like the tractor, for instance, who has taken no pains to master the various parts and their functions?* We make it our business to know our machines, what they can do, and how they are suited to the conditions prevailing in our territory.

"Fortunately for us, we are situated in the midst of the richest agricultural district in Ontario. All-year dairying is the rule in Oxford County, consequently the dairy machinery can be sold all the year round. This is one of our big lines and we endeavor to push it all we can.

"We buy everything for cash, from the smallest bolt in our repair stock to the complicated tractor. Our revenue from cash discounts in a year amounts to a considerable sum. We have always taught our customers to buy for cash, and, roughly speaking, about fifty per cent. of them do so. I have no doubt in a year or so, when the advantages of buying for cash are more fully appreciated by the farmers, we shall be doing practically 100 per cent. cash business. Buying on time has been a long-standing habit with the farmer, and like all bad habits, will take a little time to eradicate."

"What is your idea of service, and to what extent do you give service?" asked the M.T.I. representative.

**"SERVICE,"** said Mr. Fowell, "is the central pivot on which our business swings. We undertake to give full service on every machine we sell; that is, we see that they are properly installed, kept in good working condition and doing the work for which they were designed. I have driven miles and miles to do some small repair or adjustment. Some of my friends have criticized me for doing so, but I have found it pays to keep the machines working. As I said, I have travelled miles to do some service, and sometimes, when I would reach a far distant farm in response to an urgent appeal, would find that the trouble was simply a dirty spark-plug. At such moments I comfort myself for my long drive with the thought

that it was *only* a dirty spark-plug and not a bad breakage.

"We keep a large stock of repair parts on hand covering all our lines, and we are in a position to handle any repair. We are careful to keep all our lines full so that at no time may we be caught napping.

"Our service system also takes in demonstrations. By demonstrations I don't just mean placing a machine on the floor and showing it off to prospects; but a real live demonstration and at the proper place—the farm. When we started to handle tractors in 1918 we decided that the best way to sell the farmer on this new machine was to give a series of demonstrations. These demonstrations had a twofold effect: they were instructive—both to ourselves and the farmer—and were powerful advertisers.

**"W**E demonstrated the tractor in the field and on belt work. In one test, that of harvesting grain, we cut one hundred acres, using only a gallon and a half of kerosene per acre. In another test we filled and refilled two silos, 14 x 40, at the small cost of eight dollars. In a threshing test we threshed wheat for four hours at the rate of one gallon of kerosene, or in other words, 22 1/2 cents per hour.

"These tests caused a stir among the farmers and started them talking, with the result we sold nine tractors.

"That was last year. During 1920 I believe we can easily double our tractor sales. I have bought a building, adjoining our present premises, which will be used this year as a tractor garage. In this garage we will have a tractor housed and give demonstrations at every opportunity. We are well situated for doing this, as our warerooms

look into the Woodstock market, and here the farmers collect two and three days each week to dispose of their produce.

"It is our intention to display a tractor on market days. For this purpose we shall employ a man to do nothing else but drive the machine around, in much the same fashion as a horse-dealer would display a horse. In this way we hope to reach every farmer in our territory.

"We keep samples of practically every line we handle and have them displayed in our windows, at the door and on the floor.

"To sum up in one sentence: our business has been built up by hard work, perseverance, selling only the best goods, studying our lines so that we have a thorough knowledge of them, and giving adequate service—which we interpret as keeping machines going and doing the work for which they were designed."

Mr. Fowell's store is 50 x 60, two storeys and basement. An elevator connecting the three floors makes it possible to store any machine, large or small, conveniently. All repair parts are kept in the basement, neatly arranged in wooden compartments built on a frame in tiers along the walls. The arrangement of the different parts has been carefully thought out so that there is no difficulty or confusion.

Mr. Fowell, besides handling the usual implements and machines, carries cutters, incubators, extension ladders, concrete mixers, storage tanks, windmills and scales, etc.

**A**S CAN be gathered from the foregoing, he is well sold on the implement business. He takes it seriously and looks far ahead—witness his idea of a



This picture shows the ARK as it is to-day. Note the fine display of goods. Insert is Edward C. Fowell, proprietor



tractor garage and plans for practical demonstrations.

In actual salesmanship he combines nicely the aggressive and persuasive. While we were present we had an opportunity of witnessing his method of bringing a hesitating farmer to the point and clinching a good sale. It happened this way:

Two farmers came in, obviously father and son, and in a very casual way asked a few questions about a pump. Mr. Fowell showed them a pump, explained its operation and possibilities. When this was done to the farmers' evident satisfaction they prepared to leave. Mr. Fowell, with a well-timed remark, arrested their attention, and once more the discussion began, this time on a slightly different tack. The advisability of installing an engine to operate the pump and do away with useless hand-pumping was emphasized. Then with a little talk on the merits of the engine and its thousand and one uses, he had fairly



This picture shows the late John Fowell, founder of the business of John Fowell & Son, sitting in his office. Note the diploma above the filing cabinet granted by the Canadian National Exhibition, Toronto.

captured the farmers' attention. From the engine proper the discussion passed on to the various types of magnetos, and from there back to the original subject—the pump.

The farmers were fully convinced by this time that they required not only a pump, but an engine as well, but they thought another time would do to buy, and that they would come back again, etc., etc. Mr. Fowell walked with them to the door and again by a happy remark induced the men to come back to his office. Eventually, after about an hour's discussion he succeeded in registering a sale of upwards of \$200.

When the farmers had gone Mr. Fowell turning to the M. T. I. representative said:

"That is a fair illustration of what we dealers have to do to make the majority of our sales. These men really wanted that machinery and wanted it badly but they hated to spend the money. When I see a case like that I never let up until I get a result of some kind.

# If You Start An Accessory Business

By R. LAIRD BRISCOE

**B**REAKING into the accessory business on a small capital is a very interesting and, in some cases, daring venture, but the returns are often well worth the plunge. A man's chances of success depend almost entirely upon himself—whether he has the requisite character, stick-to-it-iveness, education and training in the accessory or allied lines. A very interesting letter reached the desk of the Editor of M.T.I. a few days ago, which should be of interest to so very many hundreds of our readers that we are reproducing the letter in full on this page, and in this article you will find answers to the questions which are given in the letter.

First of all, read the letter, which you will find in the panel on this page. Then go ahead and read this article.

Answers to questions:

1. Is it possible to make a beginning on a small capital?

On a capital of from \$500 to \$1,000 a man has to go very carefully, and feel his way, as it were, and he cannot look for such immediate or large returns, but by careful buying and close attention to his business he can soon see ways in which he can make his stock turn over very quickly. It may mean that he will have to be "on the job" from seven o'clock in the morning until eleven or twelve each evening for a few weeks or a few months, particularly during the busy season, but as his capital and stock increase, he will find things easing up. It would be just as well to remember that a man with small capital like this should do all the work himself, and thus save the expense of any hired help.

2. Is it customary for wholesale firms to back up an accessory dealer?

**I**T DEPENDS entirely upon the man's moral risk and his business ability. If he has had experience in the tractor or hardware line, with tractor and other accessories, he will likely have made the acquaintance of several travellers who may be useful to him in putting in a good word to the head office. In this connection any man going into the small town or small city garage or accessory business should read the article by Arthur M. Glover in the February M.T.I.

3. Can a trade be worked up without gas and free air fixtures?

Yes; but—gas and free air are the same to the garage business as sugar is to flies. Why pay no attention to one of your chief lures? A nickel-in-the-slot arrangement for air has been found very useful in a few of the urban centres. It might be just as well not to try this "pay" method until you get well established.

*Last June M.T.I. ran an account of Briscoe's accessory business, London. Mr. Briscoe has since received several inquiries, asking for suggestions. This letter, below, is answered on this page, as one of general interest.*

R. L. Briscoe, Esq.,  
258 Dundas Street,  
London, Ont.:

Dear Sir—I read, in the MOTOR, TRACTOR AND IMPLEMENT TRADE JOURNAL of June, 1919, an account of an interview you gave the journal regarding the auto accessory business, and contemplating the opening of a business of the same kind here, I need some advice, and I am convinced you can give good advice, therefore I take the liberty of approaching you on the subject. I know you must be a busy man and I do not want to encroach on your time, yet if possible, I would be very glad to hear from you.

1. In the first place, I have a very limited capital to work on—\$500 to \$1,000. Is it possible to make a beginning on a small capital? Taking into consideration that there are other firms doing business with large stocks on hand, and no doubt considerable capital.

2. Is it customary for wholesale firms to back up accessory dealers to any extent, and will they give long-term credits?

3. Can a trade be worked up without gasoline and free-air fixtures?

4. Would it be necessary or advisable to have a battery service station in conjunction?

5. In handling agencies, say for wheels, do the manufacturers sell outright to the dealer? Or do they advance him supplies?

6. Does location of store play a big part in building up a business? Would a location among or close to the other dealers be preferable?

7. What would be the most practical lines to start out with? Where the stock must of necessity be small, does the list you give in the journal apply to an exclusive accessory business or to a side line with, say a hardware or implement business.

8. I have considerable experience in hardware lines and tractor motor accessories, but I have never been in business for myself, and if you can give me a few pointers I will appreciate it very much.

Thanking you kindly in advance.

Yours very truly,

JOHN W. A., Saskatchewan.

4. Would it be necessary to have a battery service?

Battery service is going to be one of the most profitable departments of any garage or accessory business. Practically all cars are now equipped with batteries and car owners do not yet understand them, in the great majority of instances. If you have adequate accommodation to store batteries during the winter, so much the better. When the fall comes and winter draws on apace, send out letters to all your clients and prospective clients and tell them what facilities you have for storing their batteries and giving them to customers in perfect condition when they want to take their car out in the spring.

5. Do manufacturers sell wheels, and other articles, outright?

**Y**ES, THEY will sell these or any other articles outright, or on regular terms—the terms depending upon what arrangement you can make with them personally, what the traveller thinks of you, and what kind of a credit rating you ultimately secure. Do not neglect this question of credit rating; it is extremely important.

6. Does location of store play a big part in building up a business?

Yes, necessarily; it might be better in very many instances to locate at some point other than those occupied by other dealers, so long as you can get on a main thoroughfare. A side thoroughfare is of no value unless it is one of those streets popularly known as an "auto row." There are, on the other hand, some towns and cities where the automobile and accessory men have congregated in one section and to be away from here might be a serious disadvantage. You want to study the problem from the standpoint of conditions prevailing in Regina, and to observe the cars that pass different localities every day, taking into consideration their make, etc.

7. What would be the most practical lines to start out with?

We cannot do better than refer you to the article in June M.T.I., about the London Accessory dealer's business. Get as many articles on this list as you can. The prices may since have been changed somewhat, but you should be able to get all this list and more for less than \$1,000, even buying outright. It does not apply so much to an exclusive accessory business as to a side line, say with a hardware, or implement, or automobile trade.

8. Advice?

Do a cash business; sell at regular prices, never cut; keep your place clean; put out a good sign; tell everyone what you can do—and then do it; let everyone know what goods you sell—and keep them in stock.



# CANADIAN MOTOR, TRACTOR AND IMPLEMENT TRADE JOURNAL

Published on the fifth of each month by

The MacLean Publishing Co., Limited  
TORONTO, MONTREAL, WINNIPEG

JOHN BAYNE MACLEAN,  
President.

H. T. HUNTER,  
Vice-President.

H. V. TYRRELL, General Manager.

LONDON, ENG., THE MACLEAN COMPANY, OF GREAT  
BRITAIN, LTD., 88 FLEET STREET, E.C.

BRANCH OFFICES: Montreal, Southam Building, 128 Bleury  
Street; Winnipeg, 1103 Union Trust Building; Vancouver,  
39 Tenth Ave. West; New York, Room 620, 111 Broadway;  
Chicago, 1401 Lytton Bldg.; Boston, 734 Old South Building.

SUBSCRIPTION PRICE—\$1.00 A YEAR.

OFFICE OF PUBLICATION—143-153 University Ave., Toronto.

Vol. II. TORONTO, MARCH 5, 1920 No. 3

## STILL GROWING

WITH this issue of M. T. I., we celebrate our first anniversary. Just a year ago we were born, a tiny 32-page baby; but look at us to-day. We have grown to our sixtieth page and are known to more than 3,000 interested readers. We expect to keep on growing until we burst our cover strings; then something will have to be done.

## REPAIR MACHINES EARLY TO SAVE MONEY

DEALERS, now is the time to impress your customers with the fact that if missing bolts are supplied, worn and broken parts replaced, movable parts cleaned, grease cups filled and a little paint applied, their farm machines are worth more, look better and are more efficient. Improperly housed farm machinery represents a big loss, but an equally great loss comes from negligence or improper care of machines. At a time when prices of new machinery are extremely high this point is of special significance.

Getting everything lined up now in preparation for the busy season is another big saving. Labor is scarce and the loss of even a small amount of time is going to be serious again this year. The loss becomes greater as the machines men operate become larger. One man operating a tractor and three-base plow tied up for an hour is the same as one man operating a team and one-base plow tied up for three hours.

It is difficult to repair machinery if no warm place is available, but the machines can be gone over thoroughly and all broken and missing parts ordered, at any rate. This is the slack time with implement concerns, and orders received now will be promptly and carefully filled. On the first warm day the repairing can be done. A good machine shed with a repair room will show its value at this time, and it will be wise to begin planning for one next year.

General repairing consists in going over all the machines, replacing all worn or broken parts or missing bolts, tightening them thoroughly, cleaning all movable parts and bearings, filling grease cups, and getting the machines all ready to go when the season opens.

When the general repairing has been done and the parts are clean and free from grease, it is time to apply paint. Machinery should be painted occasionally, as the paint becomes worn and scales off. Ordinarily bridge paint, the universal paint for all conditions, serves the purpose best. The paint can be applied with a big brush and the work done rapidly. Paint goes a long way toward saving the life of machinery, particularly the wooden parts, as well as improving the appearance.—*Sharples News.*

## NOVEL STUNT IN ADVERTISING

DO YOU ever experience difficulty in getting the public interested in your goods? If so, how do you overcome the difficulty? We have seen many good advertisements and have heard of hundreds more, but here is one from Russia, where we have been accustomed to think the natives—like the bears—go to sleep for the best part of the year—which seems to us to take the bun. But are they so slow? Listen:

An American relates that while in Moscow before the war he one day saw a crowd gathered around a little fellow who was bawling at the top of his lungs. Many asked him what the trouble was, but he kept

on crying, and the crowd increased; then all of a sudden he stopped and said in a clear, loud voice: "I am lost. Will somebody please take me home to Ivan Tobinsky, the champion clothier of Moscow, who has a full supply of autumn overcoats, suits, neckties, shirts, hats and umbrellas, which he will sell cheaper than anyone else in the city."

## AN IDEA THAT ATTRACTED CUSTOMERS

ONE of the strongest and most direct advertising mediums a dealer or merchant has is his window. It should be skilfully arranged, renewed frequently, and on occasions an extra special display or stunt introduced, if the maximum benefit is to be derived.

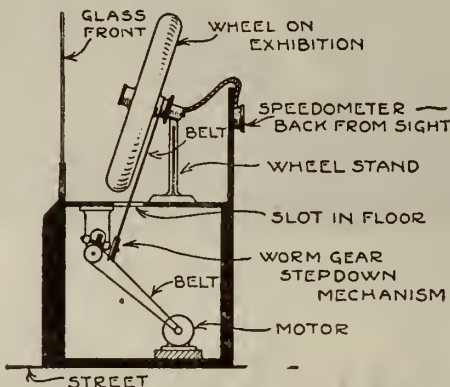

This novel tire display for a show window will attract additional customers to your store

An energetic tire dealer recently thought out a scheme whereby he could compel the public attention to his line of goods. On a display stand in his window he rigged up an automobile wheel carrying on its rim the tire he sold. By means of a small motor and borrowed worm-gear step-down mechanism, he was able to reduce the speed of the wheel to about fifty revolutions per minute. A round leather belt ran from the pulley of the worm-gear to the back hub of the wheel, which was dished, then through a slot in the floor to the driving mechanism below.

The wheel was rigged to a speedometer with its face hid from the public. A card in the window announced that a new tire would be given to the person who came nearest to guessing the reading of the speedometer at the end of the week.

Needless to say the display attracted a great deal of attention and the dealer was able to add a number of new customers to his books, which more than paid for the expense of the display.

## MORE ABOUT INCREASED MARGINS

FROM time to time there have appeared in M. T. I. articles and letters about larger discounts and margins for the implement dealer. This question is causing quite a stir among manufacturers and distributors both in Canada and the United States. As we have repeatedly stated we are strong for increases and would welcome letters from our dealer-readers stating their views on this important subject.



The Whole World Clamoring for Cars.  
—Toronto "World."

One of Saskatchewan's most up-to-date dealers, who has followed our campaign closely, writes M. T. I. as follows:

"I am very much interested in your campaign for better margins for tractor dealers. I think you are to be commended for the stand you take. I feel sure that the agitation will through time bring good results.

"I believe that a better margin of profit for the dealer would result in more and better business. The dealer should have better margin on tractors on account of the extra service that he is unavoidably called upon to render free of charge

"I believe it would result in better business for the manufacturer as the dealer would be encouraged to buy the goods outright for cash and deal direct with the farmer, thereby making more cash business for manufacturer.

"I also think it would result in a larger volume of business, as the dealer in buying outright could make terms with the farmers that at times the manufacturers would not care to make. I may add that the dealers in the United States receive a better margin in a great many cases than Canadian dealers, and it has proved there that most of the goods are bought out by the dealers and paid for in cash at time of delivery.

"I think what has proved good business over there would do the same thing here."

## THE RIGHT OF WAY

THE implement dealers of Saskatchewan are the only ones in the Dominion now organized in a section of the Retail Merchants' Association. They have been in existence a year or two, have accomplished some things, but are still feeling their way slowly.

Read Mr. Dixon's article on the first page of February's issue, addressed to auto men, and the article by G. H. Sallans on page 18, to implement dealers.

In order to further the interests of the retail implement or auto dealer in Saskatchewan or any other province, absolute co-operation and support of the association is essential. The R. M. A. officers hope that every retail implement dealer who is already a member of the Retail Merchants' Association will use his influence, by emphasizing the benefits to be derived by organization and co-operation, to induce every implement dealer in the province to become a member of the Association.

Individually it is impossible to accomplish anything, and it is only through co-operation and association with their fellow merchants, in other words, the efforts of an organized body, that any very material benefits can be obtained or useful work accomplished in the interests of each.

If the individual implement dealer is dissatisfied with the present condition of things there is only one practical method of bringing about an alteration, and that is by at once becoming a member of an organized body such as the Retail Merchants' Association.

It is certainly a move in the right direction to employ a paid organizer and managing secretary. He should be well paid, too.

## POWER ON THE FARM

AS farming enters more and more into competition with other industries in the employment of labor, and as production costs increase, the more is the need for labor-saving equipment emphasized. The farmer must call in such aids as science and invention have provided for him; he must rely more upon mechanical power and less upon brute force. As he finds it increasingly difficult to secure sufficient help to farm by his usual methods, he must necessarily turn to the employment of machinery that will increase his own ability.

More power is one of the needs of the farm to-day. Not only must our farmers employ more brain power and use greater judgment in their work but with the larger plows, cultivators and other implements they are being forced to utilize in order to obviate the shortage of help and accomplish their tasks on time, more horsepower is required. This extra power can be obtained either by keeping more horses or by using a tractor. Feed is costly and horses must eat whether they work or not. The expense on a well-cared-for tractor ceases when it stops. For this reason, the field for the tractor is broadening and as this power machine is developed to fit the needs of the general farmer, he is calling it to his assistance.

*Indiana Farmers' Guide.*



# Window Dressing for the Garage Man

By CECIL DIXON

**E**VEN a 50 per cent. garage man doesn't need to be told that his windows are a most important asset. Every progressive automobile dealer appreciates to the full extent that his window offers the most economical form of advertising that he can possibly get. Furthermore, he knows that his window DOES ADVERTISE him, whether he wills or not—he can't help it. If your window is empty it advertises the fact, if it is half full of junk it is still advertising you; there is no way of "side-stepping" this window proposition—it is speaking for you in terms of PROFIT and LOSS every minute of the day and night that it can be seen.

If you want to buy anything, from a shirt collar to a lunch, you invariably pass up the careless, untidy places, and step in and spend your money where a clean, attractive window invites you.

How often have you bought something unexpectedly because it was displayed in an appealing way that caught your eye in passing a window? How often has that new pair of shoes, that electric stove, that pipe or tobacco, that toy or doll for the youngster, that victrola, and all the other cunning inventions designed to take your money, GOT YOU, MR. GARAGE MAN? And just because it shouted to you every time you passed that window until at last you fell for it. Get wise, and play the same game yourself. *Clean up—clean up your store, clean up your window and put something in it.*

You have as good a chance as the baker, the bookseller, and shoe-man as well as the whole crowd of other merchants—they have to fill their windows full of things and keep renewing and re-arranging them. If you haven't got a good window, think it over and see if it won't pay you to have one put in. Remember this—YOUR WINDOW SHOULD PAY YOUR RENT.

**T**HE first step in any window arrangement is to get a clean start. The glass should be cleaned, for no matter how bright and shiny is the coat of nickel and enamel on the bumper, clock, mirror, speedometer, etc., the desire of the passerby to own it does not make a 100 per cent. appeal if that passerby sees it through dust and flyspecks.

Start by giving the glass a thorough cleaning inside and out. After cleaning the glass the next step is to see that you have a proper floor or base, and background. Try and arrange a suitable background, for without it the eye travels on through the window to



An excellent window with goods well grouped in the centre.

other things and the value of the "Window Picture" is lost. The background can easily be made and covered with canvas, burlap or some material like "Beaverboard"; this board has the advantage of taking a good coat of paint and looks like a permanent thing.

The material necessary to properly dress a window properly is not very hard to obtain; and if you get in touch with the merchants in your town who carry a stock of Dennison's goods you will find you can get nearly everything you could ask for in the way of paper for window-trimming material.

Attractively dressed windows have many points of

tion to call; and if you are successful in getting enough people to step into your store, or garage, your battle is half won.

You will grant that the arrangement of your store is important in its effect on customers; then, it follows that the care and arrangement of your windows is even more important, because for every one person who sees the inside of your store there are hundreds who see the windows and judge you by them. An ill-kept window repels, and a crowded window fails to attract. A well-planned and frequently changed window display sells a large portion of your stock. The art of window dressing has developed wonder-

value; they attract more people to your store.

They make a person desire the articles either for his own car or to give to a friend.

They give you an opportunity of showing NEW lines of accessories.

They fix your store in the minds of people, who will speak of you and send you business even though they never come to your store themselves.

They put character into your business and elevate your standing as a merchant.

One of the first points to keep in mind is not to put too much in the window. Keep the idea of simplicity in mind.

Raise the small accessories a few inches above the floor by setting them on blocks or bricks covered with the same material as used on your floor.

Use neatly printed price cards.

Change your windows often and always keep them clean.

**A**S you are the local representative of a great modern industry, with an enormous consumer demand and behind which there is a capital of millions of dollars, ample brains and honest high-class effort, you must try to keep abreast of the progress which is being made by the industry you represent. Make your window a polite invita-

tion to call; and if you are successful in getting enough people to step into your store, or garage, your battle is half won. You will grant that the arrangement of your store is important in its effect on customers; then, it follows that the care and arrangement of your windows is even more important, because for every one person who sees the inside of your store there are hundreds who see the windows and judge you by them. An ill-kept window repels, and a crowded window fails to attract. A well-planned and frequently changed window display sells a large portion of your stock. The art of window dressing has developed wonderfully, but any garageman can easily master the essentials, or hire some smart, young fellow to do it, and with a little effort, and practically very little extra expense, increase his sales and better his standing in the community.

Select what you wish to sell most and let that have the prominent place; not in one corner but in the middle, well back from the window pane so that the eye falls upon it readily and easily. Let the small articles be so arranged that they do not distract attention from the main feature of your display, but draw the eye to it.

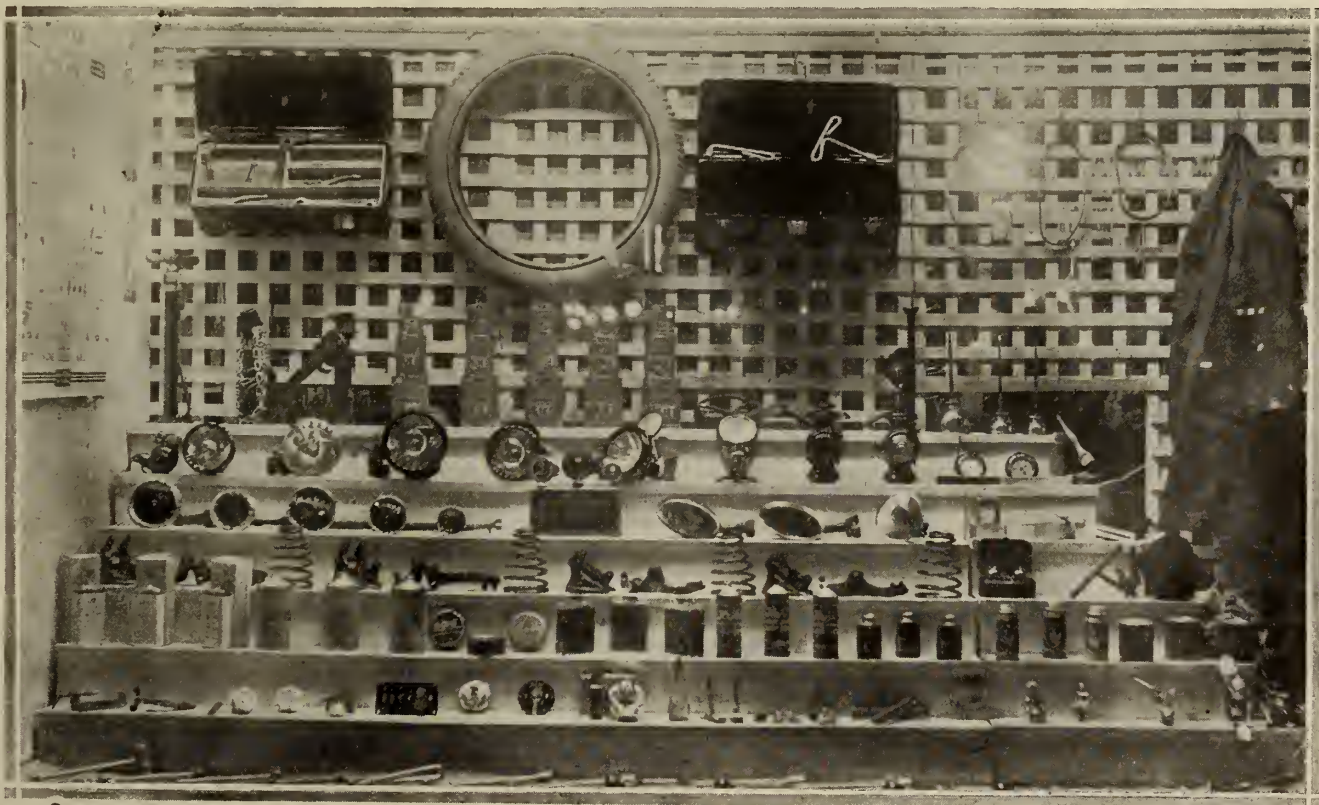

A window of a different type, but equally effective—no suspicion of crowding.



# THE IRON JINX

By B. J. PAULSON

Illustrated by  
LOUIS KEENE

TED FLANDERS, traveling road engineer for the Jumbo Tractor Company, Ltd., was guiding the Iron Jinx over the broad, level benches of the Happy Land country of Northern Saskatchewan, some hundred odd miles north of Maple Creek.

Flanders did not call himself an "engineer." He preferred to be known as a plain, ordinary "trouble shooter," for, he always maintained, "trouble" was his middle name. Nevertheless, he was a tractor engineer—a traveling expert—whose duty it was to deliver and keep in repair tractors sold to farmers in his territory by the Jumbo Tractor Company, Ltd.

On the cold, blustery November day on which this tale begins Flanders was anticipating trouble for the simple and obvious reason that his erstwhile charge, which he was navigating over the wide expanse of Happy Land, was the "Iron Jinx." The "Jinx," as the reader has already surmised, was a tractor—a hoodoo tractor, according to Flanders. He mistrusted the great, hulking creature of steel and iron—and for a number of very good reasons.

Back in the early days of gas-tractioning, shortly after the first Winnipeg tractor plowing contest which, you will remember, was held in 1908, Flanders had been introduced to the Iron Jinx. At that time the Jinx was a new tractor—a powerful, twin-cylinder monster with a 45 h.p. belt rating. To Flanders, then but a novice in gas-tractor experting, had been assigned the task of delivering this tractor to the first purchaser—a little jaunt of forty miles inland from the railroad. He had had a strenuous experience.

In fact, he had many strenuous experiences with the Jinx, beginning with the date of his introduction to the tractor and continuing until the November afternoon where we now find him. The Jinx had been sold on three different occasions, to three different farmers, taken back as many times due to failure of the purchasers to meet their fall notes when due, which had been tendered to the Jumbo Tractor Company, Ltd., in payment of the tractor on long time sales—and in each case the "remains" had been practically rebuilt by Flanders before the next sale was made. And between times Flanders had experienced no end of trouble in keeping the great tractor in proper working condition, as the purchasers in each case knew but little about gas-engine operation and consequently failed to care for the tractor properly.

The last time that the Jinx was taken back—and it had been Flanders' duty to reclaim it—he had considered the tractor quite beyond redemption and had loaded it onto a flat-car and shipped it to the nearest branch house of the Jumbo Tractor Company with his recommendation to sell it for junk.

But here was the Jinx, still very much alive and barking, on its way to the fourth purchaser, with Flanders again in charge. The tractor had been rebuilt and repainted and really looked as good as new. The sturdy main frame and great drive wheels seemed to be practically all that was left of the original tractor—and the tell-tale number plate that had long since become obnoxiously familiar to Flanders. A kerosene mixer had been added for economical operation and a snug operator's cab equipped with side, front and rear curtains which rolled up and were held in place by small straps, had been provided as an additional improvement, superseding the old canopy top which had furnished but scant shelter from inclement weather.

On the whole, the remodelled Jinx appeared to be an entirely new creation—a thing to excite admiration and command respect. Flanders, in spite of his natural aversion to this particular tractor, could not help but favor the once-more-resplendent Jinx with a grudging admiration. The job of rebuilding the old tractor had been well done. Flanders recognized this fact and he was one who always unhesitatingly gave where credit was due.

"I've got to hand it to you, old girl," mused Flanders, addressing his old-time enemy. "They sure fixed you up like a new church and made you look right pious and respectable. But down underneath the paint I know you've got a bad heart, so don't get smart and try to spring any of your old tricks this trip, such as dropping through bridges and little things like that. If you go pulling any of your raw stuff—that's where you see your finish cold, and that goes!"

Flanders derived some satisfaction from relieving his feelings in this manner occasionally. Slow, tedious tractor delivery trips over long, sunbaked miles or windy, blustery leagues had developed the habit of talking, at times, to the tractors assigned to his care. Tractor delivery trips sometimes become very monotonous and lonely. The trip ahead of him promised to be lonely—and cold.

The season was rather late for a tractor delivery but the new purchasers of the Jinx had bought the tractor for power to operate a thresher, replacing an-

other tractor of the same type which was growing wheezy and rheumatic from over-work and standing in the open during the long winter months. Flanders did not relish winter or near-winter tractor deliveries. In the present instance he had a twenty-mile delivery trip ahead of him.

However, if it had not been for a bad cold that he had contracted several days before Flanders would not have minded greatly the task now before him. But a bad cold sometimes makes lots of difference. It is quite apt to give one a pessimistic view-point. At any rate, combined with the nefarious character of the Jinx, it made Flanders feel somewhat pessimistic. He was sure that something would happen and was quite disappointed when he found that he had covered fifteen miles of his trip without incident. It was easy to determine his mileage because the Jinx had a road speed of three miles an hour and Flanders had been on the road just five hours. He had almost a two-hours' run still ahead of him and, barring accidents or unforeseen delays, would reach his destination by nightfall, as it was now mid-afternoon.

The road led over a magnificent sweep of comparatively level country which was broken by occasional coulees, usually invisible even at a short distance on the flat bench lands. Some of these coulees were deep and precipitous, necessitating laborious detours in the shape of "horse-shoe" or "S" grades which crept diagonally down the sides of the coulees, and similiary up the slopes of the opposite sides.

A stiff, biting wind which had sprung up, breezed gustily through the tractor cab and penetrated Flanders' heavy bear-skin top coat. He chilled uncomfortably and his cough began to bother him.

A thick blanket of clouds was coming up from the West and spreading over the sky. After all it might be possible that some of Flanders' calamitous predictions might be realized. This possibility became more and more probable. Snow was in the air. According to all indications a blizzard was brewing. Flanders regarded the manifestations with some uneasiness.

Northern Saskatchewan had been visited by several snow flurries earlier in the season, but in each case the fall had melted quickly. Old Boreas had been holding off his forces for an unusually long time and was now apparently growing very restless. So was Flanders. He puffed at his battered old pipe mediatively that an attack of Boreas' forces at this particular time would be highly undesirable to say the least. He hoped "Borie" would be reasonable.

But his hopes were quickly dashed. The attack began. Flanders observed the beginning of the advance in the distance. It approached with the speed of an



Flanders looking out into the storm observed a sudden commotion; a wild buck; a riderless horse; an inert body lying huddled in the road just ahead of the tractor.



express train driven and lashed by a forty-mile gale. Straight across the treeless prairie it came, a full-fledged snorter of a Western blizzard—a solid wall of white rolling forward irresistibly. It was but the space of minutes before Flanders and Jinx were enveloped in the swirling, icy onslaught.

Like the good navigator he was, Flanders took his bearings before the surrounding scenery was entirely obliterated from view. He made out a homesteader's shack straight ahead—possibly one or two miles distant—which appeared to be the nearest haven of refuge. Fixing the direction in his mind he decided to make a bee-line for that goal. Darkness would soon be upon him but the Jinx could cover the intervening distance in less than an hour's time barring accidents. On the other hand—oh, well, one always took his chances, you know.

Relieving himself of a few choice and feeling remarks as the storm gobbled up the Jinx, Flanders brought the great tractor to a standstill and proceeded to make use of the new improvements, the cab curtains, which he unrolled and fastened securely in their places by means of the metal buttons provided for the purpose. The front curtains had celluloid windows so that the operator could look ahead.

After all, the situation was not as bad as it might have been under other circumstances. The new tractor cab furnished excellent protection from the direct force of the driving storm. Flanders was very grateful for this particular improvement to the old tractor. The enclosed quarters were quite snug and the twin cylinder heads of the engine abutted into the cab, furnishing an appreciable amount of heat—especially so in view of the fact that kerosene was being used for fuel as kerosene generates considerably more heat than gasoline.

Having securely fastened the cab curtains in place Flanders decided to make his shelter still cosier and forthwith squirted a liberal amount of kerosene from an oil can into the automatic force-feed lubricator that supplied oil to the cylinders and main bearings. The object of this was to thin out the lubricating oil and consequently cause the engine to run hot—the hotter the better, concluded Flanders. He completed this little chore by giving the hand crank of the oiler a number of turns to get the kerosene-thinned oil into immediate circulation, incidentally, thereby, introducing a liberal quantity into the cylinders. He now once more gave his attention to the matter of progressive locomotion—or started to, at any rate.

Flanders was about to shift the forward-speed lever into place for a fresh start when he was aware of a horse and rider passing the tractor at a gallop. At the same instant the over-nourished cylinders of the Jinx back-fired like the report of a cannon—boong, boong! The over-dose of kerosene-thinned lubricating oil had evidently given the Jinx the hiccoughs.

Flanders, looking out into the storm through the celluloid windows of the front curtains, observed a sudden commotion: a wild buck; a riderless horse scampering away into the storm; an inert body lying huddled in the road just ahead of the tractor.

"Hell's blazes—now you're gone and done it!" groaned Flanders in eloquent accusation. "A Jinx to the finish. I might have known it. I always had a hunch that you'd do murder before you got through and now you've done it!"

Loosening the cab-entrance curtain Flanders stepped to the ground and hastened forward. He feared the worst but hardly expected the actuality. The victim was a woman; and she was not dead. To the contrary, she was sitting up by the time Flanders reached her side.

Now, if there was any one thing that could fluster Flanders, even under the most conventional conditions, it was a woman. And here was one thrust upon him in a decidedly unconventional situation! He was prepared to a face a man, but the discovery that he had to deal with a woman almost frightened him into igno-



The Jinx lurched forward at a perilous angle, and for a fraction of a second Flanders experienced a sickening gone feeling.

minious flight. However, he could hardly dodge such an issue as this.

"Er—er—I thought you were killed," stammered Flanders by way of introducing himself to his "victim," at the same time bravely assisting her to her feet—or attempting to, rather.

"Well, I'm sure it's not your fault that I'm not, so you shouldn't feel too keenly disappointed about it," replied the unskilled one with some asperity. "Why did you shoot?"

"But I didn't shoot, Miss—I didn't for a fact," protested Flanders confusedly. "That was only the Jinx heavin' a sigh—that's what scared your cayuse."

"The what?" queried the girl, for it was plain to see that she was not many summers past maturity, as she brushed the snow and dirt from her red sweater and khaki divided riding skirt and regarded Flanders quizzically.

"The Jinx heavin' a sigh," repeated Flanders desperately. "My tractor—she back-fired."

"Oh, so that was it." The storm and Flanders were both treated to a merry ripple of laughter following this acknowledgment of comprehension.

The tension being broken, Flanders somewhat belatedly bethought himself to enquire as to the lady's immediate state of health and well-being.

"Not hurt, are you?" he asked solicitously.

"I did feel rather absent for a moment," she replied good-naturedly, "but I don't seem to be able to find any bones missing—yet. I must say, however, that this road is dreadfully hard and unyielding. Fortunately I am pretty well bundled up so my fall was cushioned to a certain extent and I'm not what you could call real heavy. By the way," she continued as she straightened the becoming knit cap with two saucy white knobs on the side, which kept her head and ears warm, "does your tractor ever sneeze?"

"Er—er—you've got me guessin'," stammered Flanders.

"I merely ask," stated the questioner as she tucked a few gay stray wisps of hair into her cap, "because in the event that it does, I'd like fair warning as I wouldn't want to be anywhere in the neighborhood if

that 'sigh' was a fair demonstration of your monster's lung power, suppressed so to speak."

Flanders laughed good-naturedly and assured her that there would be no further bombastic outbreaks from the Jinx. He now recalled the stern facts of the situation.

"This puts you in a bad fix," he ventured. "Your horse went home without you. I'm mighty sorry."

"Oh, that's quite all right," she assured him generously. "Accidents will happen even to the best regulated tractors, I presume. I cannot see where you are to blame any more than my cayuse was."

"I'm afraid the best I can do to make for wrecking you this way is to offer you a lift in my private car," said Flanders. "She aint much on speed but she usually gets to where she's goin' sooner or later—mostly later. Please come aboard."

"Thank you; I'll be delighted. There seems no other course—unless I walk and I hardly feel up to it at this moment. However, I'm sure riding in your 'private car,' as you call it, will be much nicer than riding a-top of Mike—he's my horse, you know. I was getting real chilly, as this wind cuts right through to the marrow and the snow is simply dreadful!"

"It's sure fierce," agreed Flanders as he guided the girl to the tractor cab. He held aside the rear curtain and assisted his passenger aboard. He followed and snugly fastened the curtain behind him.

"Have a seat," shouted Flanders, for it was necessary to shout in order to be heard above the roar of the tractor engine and the whine of the storm. He indicated a built-in tool box at the left side of the tractor cab.

"Thank you," shouted the passenger as she seated herself.

"Come all the ways from town?" bellowed Flanders by way of making conversation, at the same time taking the steering wheel and engaging the forward speed.

"I not only rode out from town, but I rode in to town this morning," screamed the passenger in reply, as the tractor once more lurched forward and rumbled on into the storm, "eighteen miles going and sixteen miles on the return trip before the road flew up and struck me."

"Sufferin' shades of exploded gasoline!—that's some navigatin'," shouted Flanders in open admiration. "You make me plumb ashamed of myself. Here I've been complainin' pretty nearly all day because I had to make a little trip behind a pair of warm cylinders in a nice, comfortable cab—an' you ridin' over thirty miles on a cayuse without mindin' none whatever! You're sure a game one if you don't mind my sayin' so. Must have been a matter of life an' death, though."

"Hardly," replied the "game one" at the top of her voice. "I had to get a slab of bacon and my mail, you know. I enjoy riding—when it's not so terribly blizzardy."

"Homesteader?" queried Flanders in the same strain.

"Yes." There followed a brief pause.

"Used to be a school-marm, didn't you?"

"No. Guess again," was the shouted reply.

"I give up."

"Just a broken-down trained nurse."

"No—guess not 'broken down'," shouted Flanders, turning to favor his guest and passenger with a frank smile of admiration for she was decidedly good to look upon and just as wholesome and fresh as the great outdoors from which Flanders had just plucked her.

"No?" There was a pert inflection to the shouted monosyllable that invited repartee.

"Not unless that tumble broke you down—and it didn't," grinned Flanders boldly.

"You're smart," responded the "tumblee" warningly.

"Yes. My mother always thought so."

After this brief conversational exchange, if a series of shouts can be dignified by the term conversation, the two occupants of the tractor cab remained silent for some time while the ponderous tractor pounded along on its more or less uncertain way with the wind-driven snow sifting into the cab around the cur-

Continued on page 49



# ORGANIZE IMPLEMENT DEALERS AND BEAT THE DEAD BEAT

ARE you, Mr. Implement Dealer, selling implements? If so, how long does it take you, on the average, to effect a sale? How many days, weeks, years? That is, bearing in mind that a deal is not a sale until both parties have fulfilled their part of the contract, or, in other words, till the other party has the implement and you have the money.

The credit question is of prime importance to implement dealers to-day, more so than to other retail branches, because rarely, if ever, is an implement sold for cash. This is an accepted custom, a thing that has grown up with the country and has become a creed with the ultimate consumer, even though he might pay cash for everything else. Yet he got this idea from somewhere, and it grew on him. Why? Because from the start the implement dealers got down to business with the firm conviction that credit was the middle name in implement business. If you had told any implement man a few years ago that he should conduct his business on a cash basis, he would have laughed. To-day he sighs. For in some instances at least he has learned the fallacy of trying to reconcile the two by ordinary means and has possibly come to the conclusion after what he thought a full-time effort, that the thing can't be done.

Of course we know it can, for in some cases it has been done. It took initiative, but it worked out all right. It required a good start, because there was a big handicap of accepted custom to overcome. But stranger things have happened.

A HARDWARE and implement man came into the office of his friend the other day, and said: "I'm in a rather bad way. I have about fifteen thousand dollars out in unpaid accounts." He seemed naturally anxious, but any man with fifteen thousand out is going to be anxious.

"Why have you got fifteen thousand out? Why, indeed, have you any unpaid accounts?"

"What else could I do?" asked the implement man and hardware dealer, with a ghastly effort at a smile, the ghost, as it were, of his lost accounts passing over his face. "I was starting business, had to get the trade. Couldn't come out flat-footed and say this to one and that to the other. So and so wanted a binder. I sold it to him. Had to be diplomatic, most natural thing in the world, so far as I could make out. I had to give the credit."

"Why did you have to give the credit?"

"Because if I hadn't I'd have stood a fat chance against the mail order houses."

"But the mail order houses sell for cash, too?"

"Yes, but they can undersell me. I can't touch their prices."

"No you can't. And why? Because you're paying interest on that fifteen thousand. Not only that, but it's out of your hands, and you're losing interest on it that you should have. I guess you're paying the bank about eight per cent. to carry you, so that you can carry them. If you had that money you wouldn't be paying interest. The money would be paying you. Therefore, with sixteen per cent. interest against you on fifteen thousand every year, you can't compete with the mail order house. If you were free of that interest you could. Your overhead is possibly between eighteen and twenty per cent. The mail order house operates under twenty-two per cent. and can still undersell you because it sells strictly for cash."

THAT would appear to be the thing in a nut-shell. But it is not. There are other aspects which the retail implement men does not always take into account. His manufacturers and wholesalers trade all the information they can get. That's one of the most important parts of their business. "Know thou thyself, but know thy customer also."

Where the retailer loses out is in reluctance to trade information with his fellow dealers. I have a dollar, and you have a dollar. We trade, and still

By G. H. SALLANS

have each a dollar. But I have some information and so have you. We trade. The difference between the two trades is often the fence between success and failure. A would-be customer goes into one store, or implement shop. Wants to buy a binder. The dealer knows his paper is of little use and doesn't sell him a binder. The man goes across the street and buys a binder off the other man. Meanwhile you chuckle to yourself. It's good, all right. Let the other fellow give away a binder. But the next day, though you don't know it at the time, the other man turns the tables. That's where the trade comes in.

In all fairness, it might be well to remember that there are four classes of customers—farmers in this case: the farmer who can and does pay cash for his implements—there are some; the man who could pay cash but takes advantage of credit, paying in good time; the farmer who takes credit and means to pay in good time; and the man who takes credit knowing that he will not pay and does not intend to—the *dead-beat*. The last named is, fortunately, the very small minority. Even the last two are in the minority. But it is with the minority in this case that the dealer is concerned. The man who pays up in good time is not the bugbear of the business

"It all seems to me a matter of mutual education among the dealers. They don't have to be taught, exactly, but if they'd only reason it out together, they'd see that there's no necessity for credit systems unconfined. By doing business on a cash basis they can compete with the mail order house in price and can far surpass them in service. Because they have their goods right on hand, and they're right there with the advice. If a farmer wants to buy a plow for \$200, he's going to buy the plow he can examine ahead of the one in the catalogue, be it ever so well colored and described.

"Two things the dealers should remember, as absolutely essential. First, they must have a means of knowing to whom they are selling, that is if they are to continue the credit system, which, after all, cannot be done away with in a night. Then they must have a means of getting this information, and the simplest is by exchange of information. Get a line on everybody. If they can't do this, then they can inform a third party, and that third party can distribute the information. How is that all to be done? Who is the third party to be?"

A PRETTY good answer to all these questions is, "Organization." Organization with its co-operation, its endless possibilities, its credit rating bureau. The Retail Merchants' Association of Saskatchewan

has found this to answer the question so well that a special department is being created at the present time, for the express benefit of implement men and automobile dealers. Eventually this will be extended to all branches of retail service, but at present the implement men are most acutely in need of help.

A specialist right now is starting investigations, digging up files for four years back, to find out how the prices of implements have increased, whereas the margin allowed the dealer has remained practically the same, or has dwindled until there is now little or no attraction in the implement business. When he has these figures complete he will shoot them straight to the manufacturers, and he will have the retail merchants of Saskatchewan solid behind him.

But the credit bureau is the master achievement. This service is free to every retailer who cares to make use of it. With very little trouble to himself or to anyone else, he can absolutely satisfy himself as to the standing of any man in this community.

Mr. Implement Dealer, are you selling implements? Organization will not make 100 per cent. of your transactions sales, but it will bring the percentage up so close to that figure that the dead-beat will be ruled out.



A Tip to the Hibernating Dealer.

—"Motor Age."

THEREFORE, dealing with the minority, the man who meant to pay but couldn't—and the dead-beat—suppose you don't know the man's standing. That's unfortunate, for you're making a deal that is not a sale, and probably never will be a sale, for the same implement on which the wholesaler or the manufacturer made a sale to you. Of course, if you had known he didn't have the money, or that he was a dead-beat, you wouldn't have sold the implement, say it was a plow. There's profit for a month or two gone. Perhaps your fellow dealer across the way could have put you wise. If you had the credit rating of the whole community you wouldn't have needed any further advice. But, of course, you couldn't afford a credit man. Perhaps a number of dealers together could; and if he saved ten such deals—not sales—a year, he'd pay his own salary.

"It is always the merchant who makes the dead-beat," said a man recently, a man who knows the credit game from A to Z. This man says:

"A dead-beat is certainly never born. He's made; and once a dead-beat always a dead-beat.

## Automobile Shows in Belgium

THREE International Exhibitions of Automobiles and Accessories will be held this year at Antwerp, Belgium, on the occasion of the international Olympic Games which are expected to draw a large crowd of visitors to Antwerp from all over the world.

The first exhibition will take place from May 15th to June 13th, and will include motor cars, tires and wheels, mechanical parts and separate pieces, and all sorts of accessories connected with the automobile industry. The second exhibition runs from June 26th to July 25th, and will make a speciality of commercial vehicles, agricultural tractors, camions and motors. The third show will take place from August 7th to September 15th, and will be devoted to motorcycles, sidecars, bicycles etcetera, including accessories.

Reports indicate that Belgium offers a good market for manufacturers of automobiles, cycles and accessories, also for commercial vehicles and farm tractors. Accessories and parts are specially scarce there at the present time. There is also a large demand for bicycles which are very popular in Belgium on account of the flatness of the country, and which are now selling at prices 300 to 400 per cent. above pre-war figures.



*Below is one of the advertisements of Deering and McCormick Drills. This one appears in Eastern farm papers.*

*Showing McCormick Shoe Drill. Made with 14, 16, 20 and 22 shoes, 6-inch spacing. For Western Canada.*

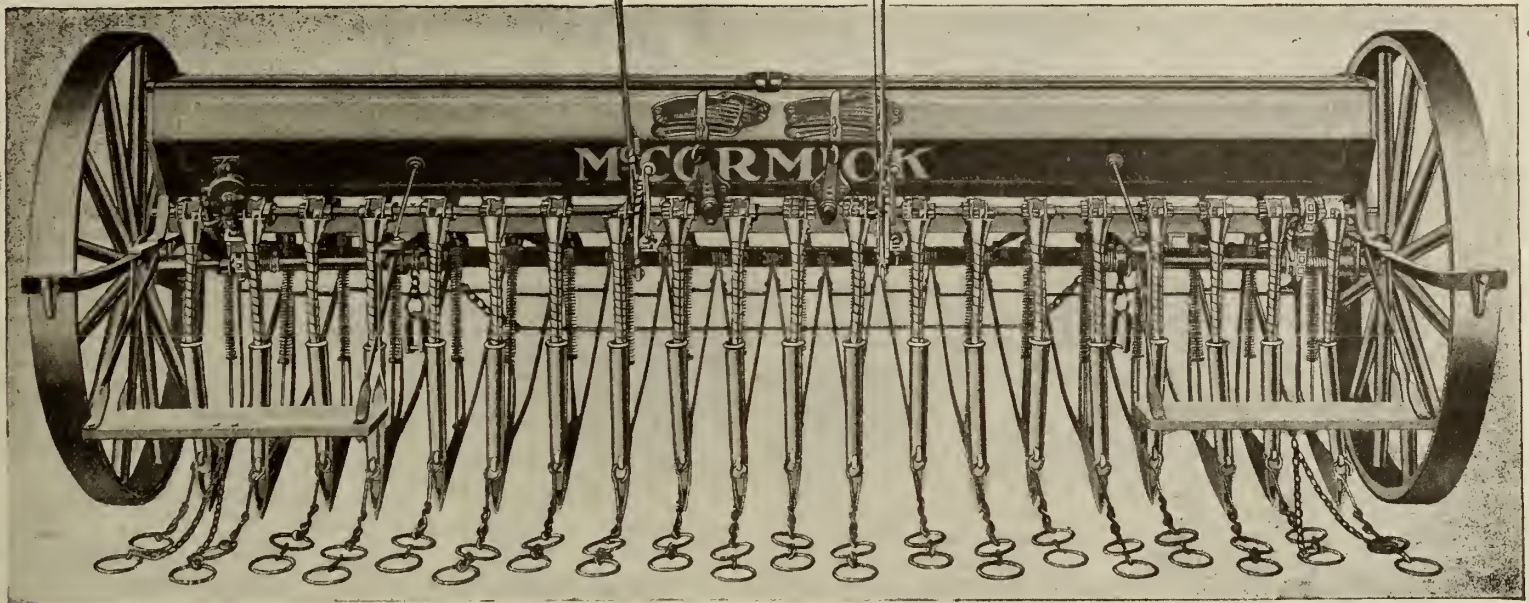

Anything  
from Flax to Beans

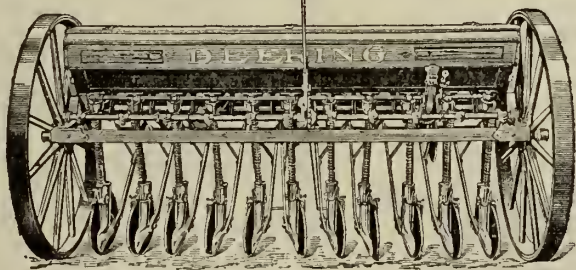

**DEERING** and McCormick single disk grain drills are adaptable. They are designed to handle successfully every kind of grain and seed from flax to corn and beans. This is accomplished by means of what is known as the double-run force feed, which consists of a small feed wheel, one side of which is made to handle small grain and the other side designed for handling large seeds, such as corn and beans. This feed is very positive in its action—it distributes the seed uniformly and there is no wedging, clogging or bunching. All that is necessary when you want to change from small seed to large seed is to flip over the feed wheel cover from one side to the other, as one side of the wheel is always kept closed by means of a center partition and this cover.

Deering and McCormick Grain Drills have many other interesting features that are fully described in the pamphlet that we will mail you immediately upon receipt of your name and address. Write to the nearest branch house. And see your International local agent now in regard to a new drill for early delivery.



**INTERNATIONAL HARVESTER COMPANY**  
OF CANADA LTD.  
HAMILTON CANADA

WESTERN BRANCHES—BRANDON, WINNIPEG, MAN., CALGARY, EDMONTON, LETHBRIDGE, ALTA., ESTEVAN, N. BATTLEFORD, REGINA, SASKATOON, YORKTON, SASK.

EASTERN BRANCHES—HAMILTON, LONDON, OTTAWA, ONT., MONTREAL, QUEBEC, QUE., ST. JOHN, N. B.

## Time for Selling Deering and McCormick Grain Drills

Magnified grain values have given a new energy to the trade in good drills. Farmers are keenly aware that every half bushel saved or added counts. They are in just the right mood to heed the many good arguments in McCormick and Deering Drills—seed-savers, crop-increasers.

With our well-laid campaign of advertising and your efforts on all the prospects you can locate—not to forget the well-merited success and popularity of these drills—you can do much with McCormick and Deering. Begin now. Our advertising in Canadian farm papers is helping you. A sample of this advertising is shown here. See the blockman.

**INTERNATIONAL HARVESTER COMPANY**  
OF CANADA LTD.

WESTERN BRANCHES—BRANDON, WINNIPEG, MAN., CALGARY, EDMONTON, LETHBRIDGE, ALTA., ESTEVAN, N. BATTLEFORD, REGINA, SASKATOON, YORKTON, SASK.

EASTERN BRANCHES—HAMILTON, LONDON, OTTAWA, ONT., MONTREAL, QUEBEC, QUE., ST. JOHN, N. B.



# THE MOTOR CAR OF TO-MORROW

*A Consideration of the Probable Change of the Immediate Future and of Possibilities Still Farther Ahead*

WHAT changes and improvements will be brought about in the evolution of the motor car within the next five or ten years? This question is the subject of a forecast by George W. Sutton, Jr., in *Collier's*. He also indulges in speculation as to the possibilities of the more distant future—crossing the continent on 10 to 25 gallons of fuel—ordinary speeds of 100 to 150 miles an hour—and other dreams such as those of Jules Verne, most of which, as he points out, came true. The following are some of the most interesting of his ideas:

Let us star-gaze a bit into the really near future and see what is going to happen during the next five or ten years. We can see these probabilities with a fair degree of accuracy.

It will be a period of gradual evolution of existing practices, with changes important and vital, but not necessarily revolutionary. Motor-car design is on a less experimental basis now so far as the main essentials and general layout of the motor car are concerned, and where improvements are made they will be of a kind not so quickly appreciated by the buyer of a car, although just as important to him as anything yet done. For example it was a big development when the six-cylinder motor first came out; another spectacular step was taken when the eights and the twelves appeared on the scene. But now we are past those major changes—we are entering on the period of refinements. For instance, engineers will be giving increasing attention to the development of the carburetor to cope with the heavier fuel of to-day. They will do great things in this direction. They must. But the buyer will appreciate it only mildly.

Undoubtedly the quantity car manufacturer is paying more attention to the appearance of his product than in any previous year. Better finish, and a proper regard for fit of the parts, have resulted in the average stock car looking more like a custom-built model than ever before. Doors shut with a better fit and there are no quarter-inch cracks between their edges and the body openings.

Upholstery in almost every case is of a better quality than in the past and cushions are so built that they will not "settle" after a few weeks' use. There really has been a great advance in the construction of motor-car cushions—due to the use of main and auxiliary springs, the placing of each in a separate pocket of heavy cloth so that it will not get out of line and sag—and in other details. But since these improvements are not seen, most of us give little thought to them.

Many of the high-class bodies are designed with much thought for the convenience of the user. There are special cabinets in some bodies for the jack, the tools, and the side-curtain fittings. Inbuilt locks for the doors and for various parts of the mechanism are placed on many of the new cars. Devices that make it easy to dim the headlights or to throw the rays of light downward when passing other cars are mounted on the steering column in several popular makes. Nearly every car now is offered with some kind of dimming lenses for the headlights. The manufacturers are simplifying this problem for the owner.

The aim to-day is to make the motor car as fine and as complete a product as ingenuity and resourcefulness can make it. Everything imaginable is done to anticipate the wants of the exacting public, not by tacking on this or that gimcrack which might possibly be of advantage, but by incorporating such conveniences as have been tried out thoroughly and found to be of practical value to the man who drives and those who ride with him.

In the mechanical feature of the 1920 car perhaps the one thing that stands

out as having received most attention is the carburetion system. Recognizing that the modern car must handle efficiently heavier fuels than heretofore, nearly every motor shows evidence of deep thought on this matter. Manifolds are provided with hot sections through which the gas must pass on its way to the cylinders, in order that it may vaporize better. Carburetors have been altered to work better with this less volatile material; and the result is that, although present-day motor fuel is far from the kind of stuff we used to buy, so far as the amount of heat required for its efficient combustion is concerned, the carburetion system has been so improved that the motorist knows very little of the worries of the engineer. To put it differently, the carburetion system has been carried forward in step with the lowering of the volatility of the fuel. And it is undoubtedly a safe prediction for the future that the motor-car engineer will meet any emergency that may arise in the fuel situation. He is at work constantly, never satisfied with the advances he has made. If anything, he has overtaken the reduction in the quality of the motor fuel and to-day the motor-car engine works more efficiently on the fuel it has to use than did the engine of a few years back on a much lighter grade.

The tendency is undeniably toward the plate type of clutch. Out of sixty-six new models made by representative car builders, fifty-seven have some form

steps, and they are usually individually illuminated by a light set flush into the apron just above.

And perhaps you have noticed that a great deal more attention is being paid to the top. It is a much more substantially mounted affair than heretofore. It appears with bevel-plate windows instead of celluloid, and in general comes nearer to being in keeping with the general appearance of the car than in former years.

A refinement which the average car owner will appreciate is the tendency to make it easier to lubricate the various parts. One or two makers have already fitted special couplings to the various grease cups on their chassis, and provide special grease guns that are easy to couple to these cup ends. By thus making it a simpler matter to lubricate the hidden parts, there is much more chance of the chassis receiving needed attention at intervals. Improvement in this vital feature will be continuous and radical.

Looking ahead for a few years, it seems probable that we are not to see any very revolutionary changes in the motor car as we know it. There will be improvements from time to time—for the industry never stands still—but it is not likely that the 1920 motor car will be out of date nearly as quickly as the models of a few years back. If you bought a 1912 model, for instance, there were so many improvements in the next twelve months that you were

Really, the outlook for the immediate future is for nothing sensational at all. The public will continue to buy the conservative and good-looking product of the wise manufacturer in preference to anything freakish.

There is a very perceptible leaning toward the car with inclosed drive, especially the sedan type where the driver sits in the same compartment with the other passengers. I have no hesitancy in predicting great falling off in the production of touring cars in favor of sedans. This movement is already taking place, and within the limit we have set, five to ten years, it will not be at all surprising to see the disappearance of the touring car as a stock model. Nor would any extras be issued by the papers if the heavy, expensively operated limousine should pass into history before the light sedan with an adjustable plate glass to exclude the driver when desired.

But what of the future car—the car of ten, fifteen, or twenty years hence? It is an interesting speculation; one in which we may all indulge freely.

The car of the future, if it is still an automobile as we know it, which the writer doubts, will be much lighter than anything of the kind we know now. It will give a new conception of road comfort; the worst roads will be smoothed out into a perfect surface for occupants of the future vehicle. Motor will be refined to the point where they will deliver to the rear wheels a greater percentage of the power in the fuel in the form of rotative effort. The wastage of to-day—the large percentage of energy that passes out in the exhaust—will be reduced to the point where for a given amount of power output, only a very small percentage of our present gallonage of fuel will be consumed. In other words, is it too much of a dream to think of a car crossing the continent on say 10 to 25 gallons of fuel? That fuel may not be the stuff we know as motor fuel—it may be a synthetic fuel of highly concentrated form—it may be an entirely new chemical combination as yet unknown for the purpose of producing motive power, but it will be a cheap product and one that will work to utmost advantage in the future engine. Even now the Government mail planes are using Liberty fuel (industrial alcohol).

Our future car will perhaps be shod with tires capable of many times the wear of our tires to-day. They may be of a puncture-proof type, very resilient, yet possessed of now unknown wear-resisting ability. Possibly they will not even be made of rubber—who can tell?

In twenty years we may have a network of underground or overhead roads for motor cars only. This is suggested by the thought that our modern car is a slow vehicle indeed as compared with a future car capable of making 100 to 150 miles an hour. We will think nothing of such speeds—they will mean no discomfort because the spring suspension—or perhaps it will be pneumatic—will be such that no bouncing will occur in the body.

We are on the eve of an era of great scientific possibilities. There is no reason for having wild dreams concerning our future method of road transportation. Likewise there is no reason why we shouldn't have them if we want to. Jules Verne had them and most of his came true.

The telephone, the wireless, the phonograph, the motion picture, the trolley car, and dozens of other revolutionary inventions are well within our memories. The motor car is almost the baby of the lot. Why should we suppose that the future holds no inventions which will supersede some or all of these things, including the automobile? But we must say, as a parting shot, if the motor car is the baby of the lot, it is some baby.



of plate or disk clutch, while only nine retain the cone type. The point is that the cone type is perhaps just as efficient as the other, but for equal smoothness of operation it must be better made and is more costly than the modern disk type. Therefore it would appear to have no advantage over the disk, and several disadvantages from the production standpoint.

Much attention is being given to methods of maintaining the space under the hood or the cooling water at an even temperature regardless of the outside temperature. This is done either by thermostatic control devices similar in action to the regulating outfit which maintains an even temperature in the home during cold weather, or it is accomplished by means of shutters that go in front of the radiator.

A rather noticeable tendency in some quarters is toward the elimination of the conventional running boards in favor of an individual step at each door. Several cars have come out with these

really out of date with your 1912 creation as compared with a fellow piloting a 1913 car. You felt it, too. But that isn't going to be the case from now on—at least, a 1920 car will not be out of date inside of three or four years.

Of one thing we can be sure. Weight is going to be cut from year to year, and no doubt new types of spring suspension will come to the front so that the riding qualities of the car of 1925 may far surpass those of our present-day cars. Much experimental and development work is being done by the spring makers, and the results so far attained are far in advance of anything the engineer even dreamed of ten years back.

No doubt we shall see changes in the styles of bodies from year to year. That is but natural. People like a change, and the manufacturers will meet that desire, but we can be sure that the lines cannot be much more graceful nor more in harmony with the best in design than they are to-day.



This Advertisement will work for you—if you are a Cockshutt Dealer.

It is one of the many attractive sales makers appearing in the larger Canadian Farm Papers.

Steady advertising and plenty of it is always behind the Cockshutt Dealer.

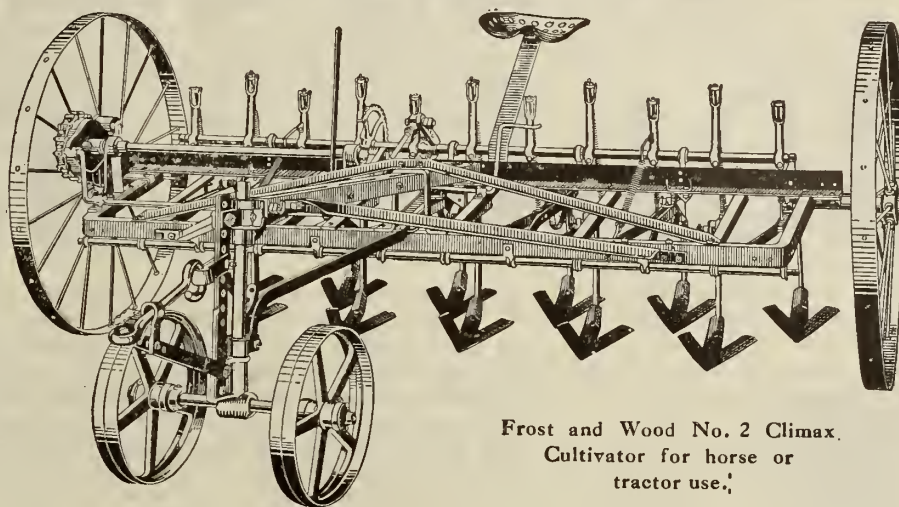

Frost and Wood No. 2 Climax. Cultivator for horse or tractor use.

## Kill the weeds and let the dollars grow—use a Climax!

The farmer who realizes the big benefits of soil cultivation is quick to see the advantages of the special design, the rugged strength, and the one-hundred-per-cent effectiveness of Frost and Wood Climax Cultivators.

The narrow points dig deep into the soil and bring up weeds—roots and all. The wide points, working at varying depths as desired, bring sure death to thistles, mustard, and everything that robs your land of fertility and moisture.

Automatic power lift works by a pull of a cord

—raises and lowers the points as desired. Handy adjustments vary depth of cut. Strength—no end to it! Strong safety springs save breakage of teeth.

Used with a tractor it cleans up your fields in short order—that's the way to get bumper crops. We have a very interesting folder—"Better Cultivation, Less Weeds" explaining these popular implements. Write us for a copy today.

See our nearest Dealer, too, and our complete line of Farm Implements.

**The Frost & Wood Co.**  
Limited  
SMITHS FALLS, ONT.  
Montreal St. John, N.B.

Sold in Western  
Ontario and Western  
Canada by

**Cockshutt Plow Co.**  
Limited  
BRANTFORD, ONTARIO.

# Cockshutt "Climax" Power Lift Tractor Cultivator

Built in two sizes—9 ft. 11-tooth and 12 ft. 15-tooth—and built for hard work.

Notice the heavy angle frame and cross bars, the substantial braces and the way the frame is trussed. Draw bars and legs to which points are fitted are carefully made. Each leg has relief spring to prevent breakage should solid obstruction be met. A pull of the cord attached to clutch lever (simple

and positive in its action) raises or lowers the teeth, as desired.

It's the latest addition to the well and favorably known line of Cockshutt Cultivators, and popular, indeed among tractor owners—farmers who must have results.

For farmers without tractors any one of the horse-drawn, lever-lift Cockshutt models will prove equally efficient for the work intended.

Get Cockshutt Literature and Dealer Proposition.  
There's money for you in handling the Cockshutt Lines

**Cockshutt Plow Co.**  
LIMITED  
Brantford, Ontario

Sold in Eastern Ontario,  
Quebec and the Maritime  
Provinces by

**The Frost & Wood Co.**  
LIMITED  
Montreal Smiths Falls St. John



# Selling Tractors Without Tractor Implements

ONCE upon a time there was a fellow who ran what he called a clothing and gents' "furnishing store." He carried a full line of collar buttons, shoe strings and other small articles. He also sold shirts, collars and underwear, but when it came to men's suits, which were the most profitable line for many of his competitors, he sold only coats and made no attempt to furnish complete suits.

Some of his friends tried to point out to him that this policy was hurting his business, and that if his customers could not buy pants at his store to go with the coats they would probably go elsewhere for the suit. He insisted, however, that there was not much money in pants anyhow, and that the coats he sold were so good that people would be glad to buy them even if they would have to try to match up pants with them from some other source, and his competitors were welcome to the pants trade.

Of course, his customers soon got to taking all their trade to the stores where they had to go to buy pants, and it was only a short time before he failed.

Then he took what was left from the wreck of his business and opened up a farm implement store, but he had not learned his lesson. He put in a stock of ordinary farm machines and was even enterprising enough to take on a line of tractors, but he drew the line at handling tractor plows and other tools for use with the tractor.

HE put up the same arguments in favor of this policy that he used to advance with regard to his clothing business. He did not believe there was much money in the tractor tools, for one thing, and anyhow, he was handling such a good tractor that the farmers in his neighborhood were sure to buy their tractor from him. He did not care if they did go to someone else to buy their plows or other tractor machines for use with the tractor, the tractor line was the big thing anyhow.

Perhaps we are in error as to the previous business experience of the implement dealer who follows this policy, but we have simply made a guess as to the manner in which an implement dealer who carries tractors only without the machines to go with them would undertake to run any other line of business. Certainly it is just as logical to attempt to sell coats without pants as to try to carry on a farm implement business, including a line of tractors, but not including tractor plows, disks and other similar machines. And the results in either case are pretty sure to be similar.

There are several good reasons why the implement dealer who undertakes to handle a tractor should also sell the various field implements and stationary machines which his customers will want to use with it.

IN the first place, it has been clearly demonstrated in numerous instances that a tractor which will work quite satisfactorily with one particular make of plow or other implement will not work nearly so satisfactorily with some other make of machine, because of a difference in the height, angle or length of hitch, or other peculiar feature.

By A. P. YERKES

A farmer judges the success of a tractor almost as much by the quality of the work he can do with it as by the performance of the tractor itself. Inasmuch as a prime requirement for the success of any tractor dealer is to have satisfied customers, and since the wrong machine behind his tractor is apt to result in a dissatisfied customer, it is quite obvious that it is decidedly to his interest to see that his customer gets the proper tools to put behind the tractor. And certainly the best way to do this is to handle those machines which have proved that they will give satisfaction behind that particular tractor.

THE dealer who takes the attitude that the tractor is practically the whole thing in the power farming line is making a serious mistake. Special tractor tools are already constituting an important proportion of business of many implement dealers, and this portion is destined to increase rapidly as time goes on. This for the reason that the number of tractors is sure to increase, creating a greater demand for tractor-drawn machinery, and at the same time the sale of horse-drawn implements is bound to decrease considerably. Then, too, the development of machines specially designed for use with the tractor is still in

its infancy. There will undoubtedly be more and more of these machines placed on the market in the future.

The dealer who refrains from taking on a line of these is not only missing the opportunity of immediate business, but is helping out his competitor to establish himself more firmly in a business which is sure to increase rapidly in importance.

There is no use in one closing his eyes to the fact that a farmer who buys a tractor from one dealer and has to go to another to obtain plows and other tools to use with it, is quite likely to transfer more of his business to the second dealer in the future because he must deal with him more or less in the matter of repair parts and replacements. If the service he receives on the tractor tools appears to him to be superior in any respect to that he receives on the tractor, which is quite likely to be the case, because of the more complicated nature of the latter machine and the greater number of parts which may need replacing, he is apt to decide to transfer all his trade to the second store, which will likely include another tractor within a few years.

Fortunately the number of dealers who persist in trying to sell tractors without machines for use with them is growing less, but it is still altogether too common to find the type of dealer who believes he can sell coats without pants.

## When Should the Farmer Buy His Tractor

By EARL B. STONE

RECORDS of retail tractor sales for more than five years past show that the farmers of America buy more tractors in April and September than at any other time in the year. And since these two months mark the opening of the busiest seasons of seed bed preparation, we are forced to conclude that our farmers wait until the very last minute before selecting their tractors. This is a practice which sooner or later will cost the majority of tractor owners a whole lot of trouble and delay and it has already brought discredit upon more than one worthy tractor. If our farmers are to get full value from their tractor investments they cannot wait until the season is on before buying.

A tractor, like any other piece of hauling machinery, whether it is mechanical or alive, must be worked in gradually to bring out its full efficiency. No farmer would think of driving his horses at a mid-season pace after months of inactivity in the barn. He knows their limitations and so works easily for only a few hours at first, gradually increasing the load and the hours as sinews harden and their wind improves. This method of building up horse flesh is such common knowledge to the farmer that he forgets or neglects to apply it to his tractor. But when the tractor gives way under the sudden strain of spring work, he refuses to consider himself in any way at fault.

Even the lesson learned from their first automobile experience, fails to impress our farmers as applicable to tractors. The auto dealers wisely cautioned them to take it easy at first. Some heeded the caution and become enthusiastic over their first machines, while others "stepped on the gas" right from the start and they got nothing but trouble and expense in return.

How much more this take-it-easy warning should be observed when starting a tractor is evident from the fact that a tractor motor does more than 20 times the work of an automobile engine in travelling the same distance. If it paid to give the automobile a thorough working in it will pay ten times over to give your tractor the same care and attention. No farmer will ever get all he is entitled to get from his tractor if he buys it the day or the week before he starts to plow. The tractor will do its level best of course—perhaps it will go through one whole season without a hitch, but he has shortened its life and in the end he will pay dearly for his last-minute purchases.

THE time to buy a tractor is a month or two before it will be needed for the hard job of breaking ground and fitting the seed bed. The farmers who are going to buy this spring will save money by making their purchase now. A month or more of easy work will get the new tractor "fit" for the strenuous day when it must sometimes work 24 hours without a stop.

Most wood lots have some fallen timber which should be snaked to the barn yard and sawed. The tractor will do both jobs and welcome the chance to limber up its gears. Or there is corn to shred, feed to grind, manure to haul, roads to clear of snow and ditches to run.

These odd jobs do two things which insure the successful operation of the tractor in the future. First of all they acquaint the owner with his tractor as nothing but actual use can do. They give him the "feel" of his machine and develop an "ear" for its song of satisfaction or cry of pain. Second, they give the bearings a chance to work and help the valves to seat more snugly. They fit piston rings to cylinder walls more perfectly than the most exact machine can do it and they limber up every gear and pinion much as the first days of easy work take the kinks out of a horse's back and legs.

Once worked in and properly maintained, the tractor is as far ahead of the horse as the Twentieth Century Limited is ahead of the olden stage coach. But it cannot do its best without a chance to limber up. When the farmer buys his tractor a month or more ahead of the busy season and works up to his peak load gradually, he will get the maximum return from his investment. He cannot expect it in any other way.



C. O. Baptist's Garage, Three Rivers, Quebec. Note the line up of Cletracs as used in Victory Loan Parade.



# Northern Electric POWER and LIGHT

A Complete Line of Electric  
Farm Plants and Accessories—

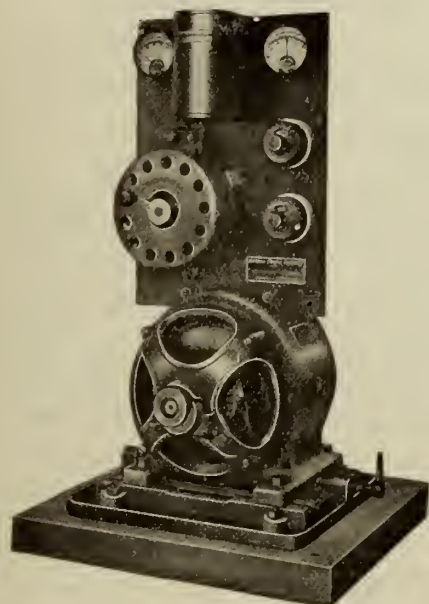

Belt connected plant—operates from any good engine.

- Belt Connected Plants
- Direct Connected Plants
- Water Systems
- Portable Motors
- Farm Accessories
- Wires and Supplies

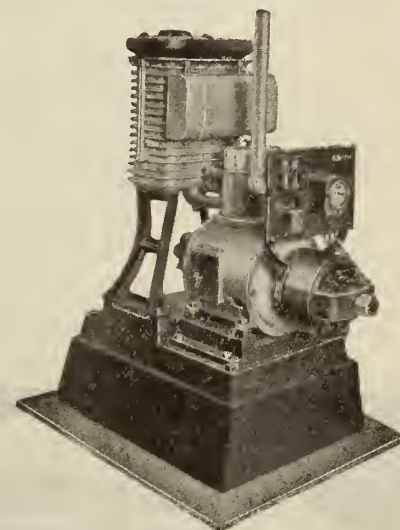

Direct Connected Utility Plant  
¼ K.W.—32 Volt

This line will make you the  
Electrical Headquarters of  
your District.

With the plant you can usually  
sell a water system while limit-  
less follow-up sales possibili-  
ties are yours with Utility  
Motors, Electric Churns,  
Vacuum Cleaners, Washing  
Machines, Dishwashers, Irons,  
Toasters, Percolators, Wiring  
Devices of all kinds, Fixtures,  
etc.



Automatic Water System show-  
ing Tank, Pump and Motor.  
Capacities 100 to 1,400 gallons  
per hour.

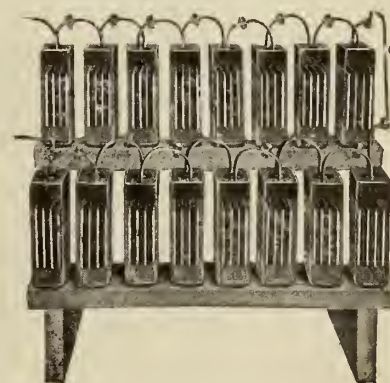

TITAN Storage Battery. 16  
Cells supplied with each plant.  
120 or 216 Ampere Hours.

Write Our Nearest House Now.  
Be the Farm Electrifier of your District.

## Northern Electric Company LIMITED

Montreal Quebec Toronto Winnipeg Calgary Vancouver  
Halifax Ottawa London Regina Edmonton



*There's Profit in Selling  
Belting, Hose, Packing to  
Farmers on the Goodyear Plan*



**B**ECAUSE Goodyear places in the hands of every Goodyear Mechanical Goods Service Station (1) quality products already sold in large quantities to farmers; (2) a selling plan which has proved time and time again the most effective means of securing big sales quickly.



# Sales Brought to You

Goodyear believes that the man who sells belts, hose, packing, to the farmer should have more direct, valuable selling assistance from the manufacturer. Customers should be brought to him. Sales should be made easier. Information of value in his business should be given to him.

Goodyear Mechanical Goods Service Stations get that kind of assistance.

## Advertising to Every Farmer

Goodyear Mechanical Goods for farms are advertised to every farmer in Canada through all the leading farm publications.

## Analyzing Your Territory

We have found very many dealers who did not know the possibilities which their territories offered. Any general store can add materially to its business by properly going after the farm trade. Every Goodyear Mechanical Goods Service Station can secure from us an analysis of his territory which will clearly point the way to every possible sale—show him how to get those sales.

## Giving You Prospects

We have on file the names of possible purchasers of Goodyear belting, hose, packing. These names are free to any Service Station. You can find out from us the men in your district who should be your customers.

## Advertising for You

We will advertise you to your prospects at a small expense to you. We will mail them letters and printed matter bearing your name. This advertising is prepared by an expensive staff of writers and artists. It costs far more than any one dealer could afford

to spend. But it is offered to Goodyear Mechanical Goods Service Stations.

## A Farm Encyclopedia Free

There are many different machines in use on farms—tractors, gas engines, electric plants, threshers. No one has ever before told the dealer exactly what belting or hose or packing to give out for each particular machine. Goodyear has done it now. Goodyear Mechanical Goods Service Stations receive free a big encyclopedia containing all this information.

## Selling for You

*Wherever a Service Station requests it we will send a Goodyear salesman to help call on his prospects.*

There are no strings to this extraordinary offer. The Goodyear salesman helps call on your prospects, sells them all he can, and turns the orders over to you.

You get every cent of profit on the sale. You get the benefits of a highly-trained selling force.

A Goodyear salesman will gladly call on you and explain our co-operative plan of selling. Wire or write the nearest branch if you are interested.

**The Goodyear Tire & Rubber Co. of Canada, Limited**

Toronto

Ontario

**GOODYEAR**

MADE IN CANADA

**BELTING - HOSE - PACKING - FOR FARMS**



# SHOP NOTES FOR THE GARAGE MAN

Where to Get Thrust Bearings—Repair Broken Mica Windows—Wheel Hub's Service

Conducted by SCOTT T. DUTHIE

## Dry Cure Methods of Vulcanizing

By F. H. SWEET

THERE are two methods of vulcanizing when making sectional repairs or retreading, that best adapted for general use being the dry cure system in which the desired pressure for vulcanization is secured with pads instead of with an air bag, and where the tire is cured by the application of heated elements rather than wrapping it and placing it in a steam oven. A number of moulds used in the dry cure system and sold for use with the vulcanizer are used. A useful one is known as an inside patch or relining mould and may be used in relining, patching or for drying out the interior of a casing before a reinforcing is started. On blowout work, especially of the larger and more difficult class, it is often necessary to apply two or three layers on the inside of a tire, and although considerable heat is conducted from the outside it is well to give the repair a twenty minute cure on the inside.

Solid pads and clamps are used in connection with various types of moulds for obtaining pressure on the curing stock. These pads conform to the curvature of the mould on which they are used. There are a number of advantages given for the pad and clamp system, over the air bag system. It is said that the properly built pads last indefinitely, whereas the air bags have a definite life and are subject to the uncertainty incidental to the use of pneumatic appliances. With a solid pad on one side of a repair and a substantial accurately machined mould on the other, and with three to five heavy iron clamps drawing the two together, it is possible to exert more pressure on the curing stock than by any other system, and pressure is considered an essential to good work.

The pad and clamp system is simple and easy to operate, and there is nothing in its operation that calls for skilled labor. It not only produces considerable pressure on a repair, but localizes the heat to the portion being repaired. Retreading may also be easily accomplished by the dry cure method, but this is only practical if the layers of fabric are in good condition. The old tread is stripped off and the new tread cemented on and vulcanized by the use of a retreading mould.

These retreading moulds are about 26 to 28 inches in length and heat approximately one-third of the circumference of the tire at one time. The moulds are hollow, allowing steam circulation from one end to the opposite and have an opening at the lowest point to exhaust the products of condensation. Sectional moulds are simply short retreading vulcanizers. They are used for curing the tread portions where the injured section is not long enough to call for the use of the retreading mould. Sectional moulds are the forms to use for surface cuts, and blisters, stone bruises, short patches of loose tread and other defects confined to a specific area of the tire.

### SOFT-NOSED HAMMER

THE repair man often requires the use of a soft-nosed hammer, especially when replacing bushings and such work. He can make his own hammer without much trouble. A T-connection

filled with babbitt and a half-inch pipe for a handle and the hammer is made. The outer end of the babbitt should be lapped over the pipe to make it secure and prevent it from being knocked from inside the T-connection.

### PUNCH AND DIE

IT IS much easier to punch holes in thin metal, fibre or composition, than to drill them. A drill press may be used for this work and the set up is

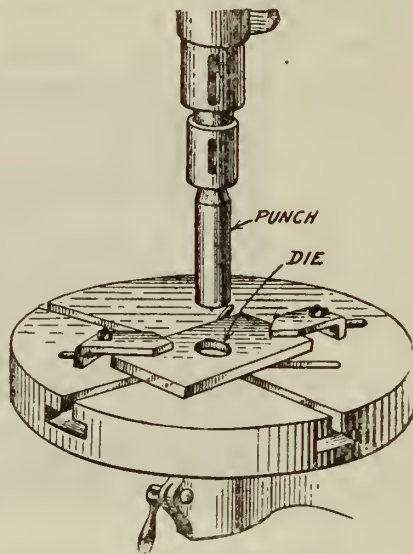

Drill Press Punch and Die

shown in our illustration. The drill and punch may both be of soft steel, but if so, it will be found necessary to case harden the end of the punch. The punch makes a better and rounder hole than is possible with a drill.

### STRAIGHTENING BENT AUTOMOBILE FRAME

THE repair man is called upon almost every day to straighten a chassis frame that has been bent. There are many ways of doing this but the

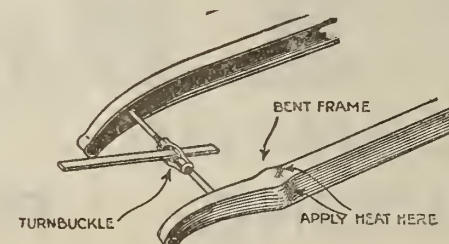
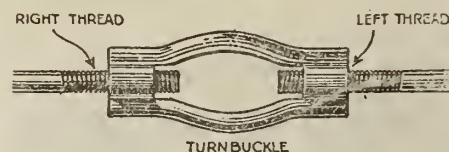

method indicated in the illustration would seem to be the simplest and quickest. The heat from an ordinary

gasoline torch is sufficient to soften the metal to the point of bending, and with the use of a turnbuckle the chassis is easily straightened. As it only requires enough heat to bring the metal to the bending point a comparatively small torch can be used.

### MAKING THE CONE CLUTCH TAKE HOLD

THE cone clutches, when they are inclined to slip, can be induced to take hold by applying some glycerine of the best quality to the leather facing. If the clutch is fierce in biting a little graphite added to the glycerine will correct the fault.

### TO PREVENT SHORT CIRCUITS

THERE is frequently danger of short circuits in the battery because of the fact that one of the terminals is located near the metal handle used for lifting the battery. To obviate this, it is only necessary to slip a short length of rubber tubing over the wire at the point where the contact might be made.

To do this the tubing should be slit lengthwise, slipped over the wire and taper firmly in place. It is a good plan to follow this practice wherever there is danger of the wires rubbing off their insulation and so establishing a short circuit.

### TO LOOSEN VALVE CAPS

WHEN a valve cap sticks and refuses to yield to ordinary efforts, it can be loosened by allowing the engine to run for several minutes until the cap is heated; and then by pouring a little water in the recess of the cap a sudden contraction takes place allowing the cap to be unscrewed.

### V LIFT

A HANDY lift to be used in conjunction with chain blocks for raising the front end of Ford cars has been devised by J. Angrove, Kingston, Ontario. A piece of 1 1/2" steel about 5' 6" long

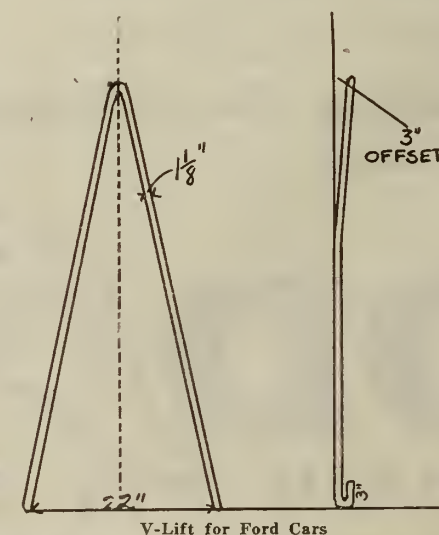

is bent in the shape of a V, as shown in illustration. There is a "turn up" of about three inches at each end to enable the lift to engage the lamp bracket nuts under each end of the front cross member. An offset to clear the radiator completes the tool.

### TUBE SKIVING MITRE BOX

IT IS necessary in splicing inner tubes to "skive" or bevel the ends prior to splicing. The illustration shows a mitre box designed for that purpose. It consists of a narrow board screwed to the bench, and carrying a hinged channel piece that is slotted at 45 de-

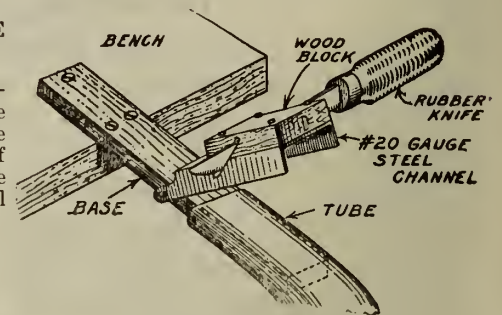

Tube Skiving Mitre Box

grees and has a slotted wooden block mounted on it. The tube to be beveled is slipped over the board as shown in illustration, until the end lines up with the slot. The channel is then pressed down, the rubber knife inserted in the slot, and the tube beveled. It is of course necessary to turn the tube around that all parts of the end come successively beneath the knife—Good-year School of Tire Repairing.

### SOME NOVEL TROUBLES

H. F. CURRAN, in *Motor Trade*, says: "A customer came to me not long ago, with the story that there was something wrong in the rear axle of his roadster, as she was making a slight bump or knock. He suggested that there was trouble in the gears. I tried the car out and sure enough he was right about the knock, but the rear gear knock proved to be only a loose rim on the rear wheel. Although the lugs seemed to be tight at first, a little muscular effort on the wrench soon silenced his gear knock.

"I heard of a car owner who complained of a noise as though there were some of the gears in the transmission or differential rubbing and making a mild sort of a grind, and nothing would do but the transmission and differential must be taken down and examined to find the noise. This was done at a cost of about fifty dollars; but no trouble was found in either place. After another tryout the noise was found to have been caused by the fibre speedometer gear meshing too tightly with the large gear on the front wheel. This owner wasted \$49.75 on his car.

"I had another case where a customer called me up and told me that his carburetor was dirty or needed adjusting as his car would not pull up the slightest grade even in low gear, and was continually spitting back through the air intake. I found the trouble to be that the breaker points were too close together. This was caused by using a pair of pliers to loosen the steel breaker cam, which roughened it up and caused it to act like a file on the fibre insulation on the breaker arm. This caused the points to come together with the above result."

CHILLIWACK.—A. S. Goard Motors Limited, dealers in Canadian Ford cars, accessories, trucks, tractors and implements, are erecting a new garage and showroom, 55 x 100, with a workshop 50 x 20.



# You Can Increase Your Income By Selling John Deere Implements

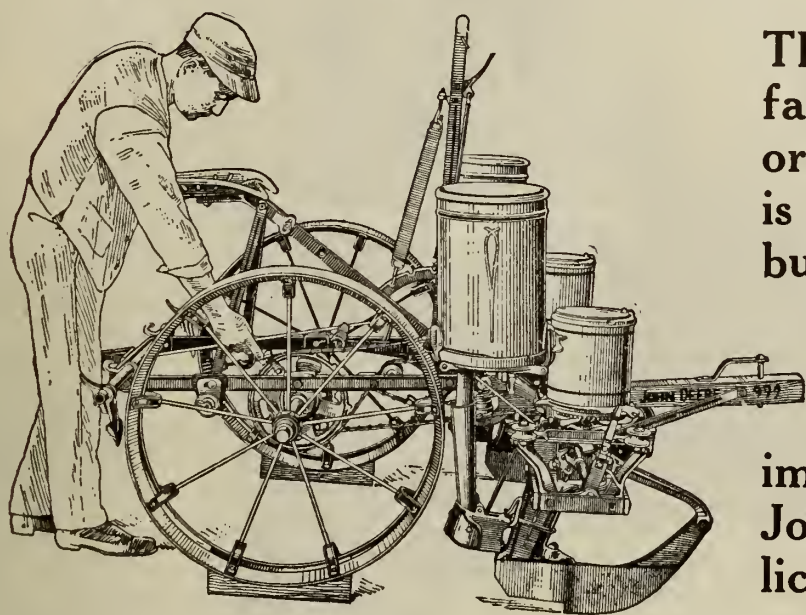

They have exclusive features. Farmers favor them. You are sure of repeat orders and the John Deere sales contract is decidedly liberal. Capitalize on your business investment and on your ability as a salesman. John Deere will go farthest toward helping you do that very thing. Here are a few of the implements that you can sell right now. John Deere advertising in the farm publications will help you.

## John Deere No. 999 Corn Planter

This is known as the accurate corn planter. It is as accurate as the human hand. Farmers prefer it. It is possible to plant 2, 3 or 4 kernels without changing the seed plates or stopping the team. The operator can change from hilling to drilling instantly. He gets nine different drilling distances without changing the plates. A kick of the foot does it. He doesn't have to get off the seat.

You can sell the John Deere Co. 999 Corn Planter equipped with a fertilizer attachment. This successfully distributes any standard fertilizer at the same time the corn is planted. It won't choke up and the fertilizer cannot come in contact with the seeds.

### Hoover Visible Potato Planter

Another implement that is a money maker for dealers as well as farmers. It is absolutely accurate. It enables the farmer to do better work faster. The picking and dropping mechanism accurately plants seeds in each

hill and spaces properly without effort on the farmer's part, except to adjust easily operated levers. The dropping mechanism is in plain view all the time—the farmer sees the result of his planting as he goes along. Then there are the spring-pressure furrow openers and adjustable disc coverers regulated by one lever. This machine is easy to sell.



### John Deere-Van Brunt Drill

(Single or Double Disc)

This machine has the wonderful Adjustable Gate Force Feed that is protected by patents. It is a big selling point. It is a feed that handles any size seed without choking. Seeds leave the grain box in steady streams. The flow is absolutely uniform. A simple lever regulates the flow of seed. No seed wasted. A farmer can soon pay for this machine with the saving on seed.

The John Deere-Van Brunt Fertilizer Drill is the most efficient drill you can sell. It is a combination grain and fertilizer drill that can be used to sow either single or both at the same time. All Van Brunt Disc Bearings are guaranteed for the life of the drill. If they should happen to show signs of wear we will replace them free of charge.

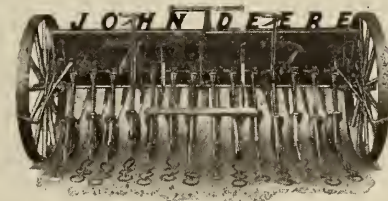

Get behind the John Deere line of quality implements—get the utmost out of your sales efforts

**JOHN DEERE MANUFACTURING COMPANY, LIMITED**  
WELLAND ONTARIO



# THE BIG SPRING OPPORTUNITY

*Dealers Should Profit by Selling Barn and Stable Equipment*

ON every hand there are evidences of a coming boom in barn building this spring. Implement dealers, implement salesmen, roofing and paint companies all report more prospects for new barns than they

summer. Certainly the demand is there and everything indicates a rush of barn building contracts when spring opens up.

But the labor question is another matter. There seems to be only one

in bad state of repair. This has brought home to many farmers the impermanence of wood equipment. The durability of steel is one of its many good features. In another ten years, hundreds of the farmers who are building or remodeling now, will be thinking of retiring. They will want to sell their farms and will naturally want to get the best possible prices for them. By that time there will be small demand for barns equipped with rotten wood floors and untidy worn out stalls. In ten years' time steel equipment in the barn will be demanded by the man who purchases a farm.

In addition to this, Government regulations are rapidly growing more strict. The conditions under which milk and cream may be produced for city consumption are becoming more stringent every year. The Act of the Eastern Ontario Dairymen in requesting the enforcement of the Dairy Standards Act of 1916 is in itself a striking sign of the growing demand for clean, sanitary, dairy products. Cattle cannot be kept free from disease in unsanitary stables. This fact is rapidly becoming more widely appreciated by Canadian farmers. As a result the demand for sanitary stable equipment is growing by leaps and bounds and the aggressive agent cannot fail to profit by it.

ONE extremely good feature of the stable equipment business is that there are no second hand goods to bother with. When a farmer tears out old stabling there is nothing which he

steel stalls are there for a lifetime. Every implement dealer knows how much time and energy he spends in making trips to repair and fix up different kinds of farm machinery. One of the great beauties of steel stable equipment is that this is unnecessary. Any minor repairs that are required can be made by the farmer himself without the necessity for calling on the dealer.

At this season of the year, when other lines are comparatively slack, the implement dealer can very profitably employ his time in canvassing the good farmers on his territory with a view of finding out these men who are intending to build and remodel this year. The lumber dealers, sawmills, barn framers and carpenters can often give the dealer a good idea of the men who are putting such work in hand.

The margin of profit in the steel barn equipment line makes the agency desirable. In 1920 of all years, there is an exceptional chance to make money in this way. Profits of \$500 to \$1,000 in a season are not by any means uncommon, as a good outfit of stable equipment runs into a large figure. Any implement dealer, even if he never gave any particular share of his time and attention to this line in former years, would be well advised to do so now. Some dealers are going to do well this coming season by the sale of stalls and stanchions.

Now is the time to sell this equipment. By getting in touch with farmers now, when they are thinking the matter over, their order can be made secure. Talk over the stable plans with them. A farmer will be only too pleased to discuss plans for his barn. In another couple of months, farmers will be busy on the land and will be too busy to talk. They are in the humor now.

TORONTO.—The Fire Chief the Architect and the Property Commissioner, have sent a strong recommendation to the Property Committee, opposing the issuing of any permits in the future for the erection of public garages with living apartments over them.

## THE CHAUFFEUR'S VIEW

"So you find pedestrians very careless?"

"They're the limit. The last fellow I ran over ruined one of my tires. He must have been carrying a package of tacks in his pocket."—*Browning's Magazine.*



Tractors owned by King Albert of Belgium, on his farm near Gaile, twenty-five miles from Antwerp. These tractors were delivered last year through New York representatives of the Rumely Company. His Majesty is well pleased with these tractors, which have proved themselves "fit for a King."

ever had before. Firms supplying barn equipment and all the various materials required in building a barn report the largest volume of business for spring delivery they have ever experienced, in their history.

Everything points to the biggest barn building year on record. 1919 was a big year, but the war was only just over, and there were many uncertain factors. Many a farmer waited to see how prices would go, whether the tariff would be amended and so on. Practically all these uncertain elements are now on as permanent a basis as they are likely to be for many years to come. No sudden changes can be looked for. This being the case, farmers all over the Dominion are preparing to increase their facilities and produce the maximum in crops, produce and livestock in order to cash in on the abnormally heavy demand with its consequent high prices.

The logical outcome of this almost complete stoppage of normal building activities is that cities and rural districts alike find themselves short of absolutely necessary buildings. It is for this reason that we feel there is a tremendous opportunity awaiting the live implement dealer. Prices of farm products are still high. This spring there is every chance that they will reach new high levels.

As we write the wheat commission has increased the price of Ontario wheat by 25c per bushel following the increase a few weeks ago of 50c per bushel for Western wheat. Hogs are back to high levels again, and in common with cattle are bound to be high from now until next summer. Dairy products have reached new high levels with no end in sight.

When the farmer lacks buildings and facilities for increasing production (as he emphatically does at the present time owing to suspension of building during the war) and at the same time has the money to buy them, it is only logical to expect a boom in barn building.

Nor is this all. On no class has the present labor shortage fallen with greater weight than on the farmer. Not only has the war left him short of buildings and equipment but good farm help is, in many localities, unobtainable. It is to be expected that many men will build afresh or extend their existing buildings this coming spring and

way out of the difficulty and that is to so improve equipment in the barn that one man can do more work in a given



With belt power equipment, operated by the tractor, idle days can be transformed into busy, profitable days, whether working for the farmer individually or rendering service to other farmers in some form of indoors work. Illustration shows tractor baling outfit engaged in baling straw—a profitable "idle days" enterprise in many localities.

time. The invention of the modern steel stall and stanchion combined with the manure and feed carrier, the automatic watering system and the like have done a great deal to make stable work easier for the farmer.

EVERY modern invention has to go through a period of suspicion. This has been true of the binder, the cream separator, the milking machine and many other time and labor-saving appliances sold to-day by the implement dealer. Steel cow stalls and stanchions have also had to establish themselves in the esteem of the agricultural community, and they have certainly done so. Their greater permanence and greater convenience have quickly made them popular. They have been proved on so many farms to save time, feed and labor; to keep the cattle cleaner and more comfortable and to stand up under the hard wear and tear of daily work that they are easy to sell. Beyond all question, the aggressive implement dealer who handles barn and sanitary stable equipment during this spring and summer should make good profits. The demand exists and only needs attention to turn it into tangible orders and profits.

The wood stalls installed in many barns ten or twelve years ago are now

can expect the implement agent to take in part payment for the new material.

There is no necessity for extra trips to make repairs. When once installed,



Winter scene on the farm without a water system.



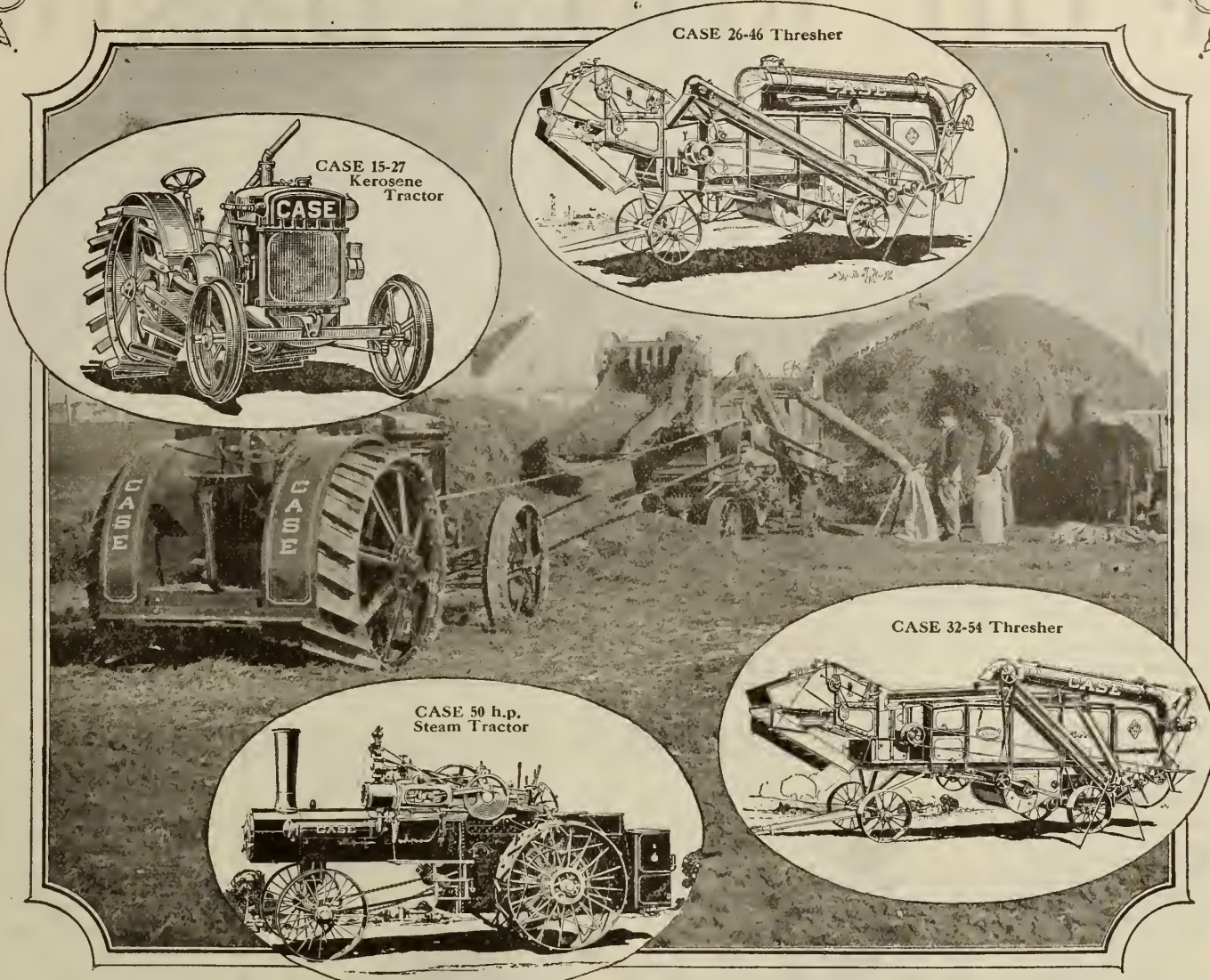

## Steam Tractors as well as Kerosene Tractors are Built by The J. I. Case Threshing Machine Co.

Don't let the popularity of Case Kerosene Tractors blind you to the sales opportunities in Case Steam Threshing rigs.

Many years before the first Gas Tractor was thought of, we were building the best Steam Tractors that *could* be built. Some of these old-time Steam Tractors, older than many of the men who read this, are still in service, delivering their full rated power at drawbar and belt.

Do not think that because of the great demand for Case Kerosene Tractors, we have neglected the Case Steam Tractor. Each has its field of usefulness and both have been developed to the highest standard of modern efficiency and economy of operation and maintenance. No dealer should overlook the sales opportunities in the Case "steamer". It always has been in demand and always will be.

Write for any sales information you need on Case Tractors, Kerosene or Steam, and the great line of tractor drawn or driven machinery we build for use with them.



Look for the EAGLE Our Trade Mark

**J. I. CASE THRESHING MACHINE COMPANY, Inc.**  
Dept. O-3, Racine, Wis., U. S. A.

*Making Superior Farm Machinery Since 1842*

**Case Distributors in Eastern Canada:** Canadian Fairbanks-Morse Company  
Montreal Toronto Hamilton Halifax Quebec St. John Ottawa Windsor

*To avoid confusion, The J. I. CASE THRESHING MACHINE COMPANY desires to have it known that it is not now and never has been interested in, or in any way connected or affiliated with the J. I. Case Plow Works, or the Wallis Tractor Company, or the J. I. Case Plow Works Co.*

**CASE**  
TRADE MARKS REG. U. S. PAT. OFF. AND IN FOREIGN COUNTRIES.  
**POWER FARMING MACHINERY**



# THE OIL ROOM DANGERS

*An Underground Tank is the Only Safe Place For Storing Gasoline and Naphtha*

By F. H. SWEET

**I**N CONSIDERING the dangers attendant upon the storage and handling of oils, we are apt to think only of gasoline and naphtha. This is a great mistake, as every oil carries with it a menace to life and property, and its handling should be safeguarded in every possible manner. Until this fact is universally recognized and all oils are handled in fire-proof, evaporation-proof, steel storage tanks, we may expect to pay an enormous fire loss due to the careless handling of these products. It is true that the danger of handling gasoline is greater than in handling other oils. This danger is so well known, however, that familiarity with it has in many cases induced carelessness, so it is well that we consider the treacherous nature of this product that we may always be on our guard.

Gasoline, unlike the other heavier petroleum products, throws off an explosive vapor constantly, even at extremely low temperatures. Five gallons of gasoline will generate eight thousand cubic feet of gas, which, when ignited, expands to four thousand times this space. The explosive force of one gallon gasoline properly mixed with air and compressed is equal to eighty-three and two-thirds pounds of dynamite. This means that if you have one hundred gallons of gasoline on hand, you are storing the equivalent in explosive force to 8,366 pounds of dynamite. Gasoline is, in fact, more dangerous to handle than dynamite, and there is more liability of an explosion. Dynamite will only explode from two or three causes, which may be easily guarded against and which must occur in its immediate vicinity.

The vapor from gasoline is heavier than air. It settles to the floor and runs along the floor much as a stream of water would, only that it is an invisible stream. This vapor will settle and remain in a depression in the floor or under the floor for days and even weeks, unless disturbed by a circulation of air, until a spark causes the accumulated vapor to explode. This spark does not necessarily have to come from a lighted fire, but may occur through a person striking a nail in their shoe on a nail in the floor, or other similar unavoidable causes. The records show that under certain atmospheric conditions, spontaneous combustion will occur in this accumulated vapor. A case is on record in which the gasoline fumes were carried outside of a building, to a lighted lamp thirty feet away from the building, taking fire and flashing back to the building, which was entirely consumed. If you are handling gasoline in any way but the right way, you are in just this position and you can never foresee when the blow will fall.

**I**T IS past understanding, in view of these facts, that many concerns, with their entire capital invested in the business, will give so little thought to safeguarding their interests. With the factory, shop, mill or mine heated, they will at night lock up this explosive in a warehouse or building adjacent to or connected with the main plant. After locking up fire and this explosive together, they will, in effect, wager their entire investment against the merely nominal expense of fire-proof storage that this vapor and the fire will not get together.

Kerosene is not as dangerous as gasoline, yet at a temperature of seventy degrees or over it throws off an explosive vapor. At a higher temperature, say eighty degrees, in order to properly ventilate a room in which there is an open tank of kerosene, there should be kept up a circulation of air equal to two hundred cubic feet a minute for each gallon of the exposed oil. These figures vary, of course, with the volatility of the oil and the temperature of the air and oil. Such a circulation of air is not practical in the usual manufacturing establishment. Hence

the necessity is apparent for evaporation-proof, scientifically correct storage for kerosene as well as for gasoline.

All petroleum products, including lubricating oils, produce this explosive vapor. The danger from lubricating oils, however, is chiefly from spontaneous combustion where waste, sawdust or shavings are used to absorb the oils spilled on the floors. Many fires in factories and the oil rooms have been traced directly to this cause, as it is a very common practice to neglect the accumulated refuse, which, in time, bursts into flames.

The gravest danger that confronts the consumer of oils aside from the gasoline danger is, however, from the paint oils, such as linseed oil and turpentine. A piece of cotton waste saturated lightly with equal parts of linseed oil and turpentine will, if left in a closed room, such as an oil house or

quantities of various dangerous oils. Happily, we are, also, in an age when master minds have set themselves to the problem of minimizing all such dangers. The storage and handling of oils has been reduced to an exact science, so that there are now available means of handling gasoline as safely as spring water.

Special equipment has, also, been designed for handling each and every oil in a manner best suited from the standpoint of economy, convenience and safety. The up-to-date merchant and garage man to-day is taking advantage of these appliances, so that we may in confidence look forward to a time when fires caused by careless handling of oils will be unknown. This will be brought about by various causes. The instinct of self-preservation is strong with everybody, and all must realize the risk in the careless handling of explosives.



The Right Kind of a Strike.

store room for the night, burn from spontaneous combustion in three hours' time. Instances are not even lacking of fires being started in this manner when the waste of oil-soaked cloth was left in the open air. Two years ago a fire occurred in one of our large cities from a cloth which had been used in oiling a floor and was left on the porch. One small state that I happen to know of has, in the past year, suffered a loss running up into hundreds of thousands of dollars from fires started by spontaneous combustion in oil houses. This property loss is appalling, but who can estimate the value of lives sacrificed annually to the mistaken policy of "economy" in equipping an oil room?

**W**E are living in an age of increasing danger to life and property from many causes unknown to our fathers. Developments of modern inventions in all lines, such as electricity, automobiles, etc., each brings its corresponding increase in danger to life and property. These advances in the development of our civilization bring a responsibility that we cannot ignore. The merchants and the manufacturers to-day are compelled to meet the conditions. For instance, they are compelled to store large

The fact that these safety appliances conserve the efficiency of the product, preserve the quantity intact and enable losses to be turned into profits brings enormous pressure to bear on the thoughtful man. Public opinion, national and state safety boards, will soon demand that every man will, at least, cease to menace his neighbor's property and his neighbor's life by unnecessarily lax methods in the handling of dangerous explosives.

The prices of all kinds of oil and general economic requirements demand the proper storage and distribution of these liquids. Millions of dollars are annually lost, due to the deterioration of the quality and waste in handling improperly stored oils. Hot and cut bearings, prematurely worn machinery are very frequently due to deteriorated or contaminated oil. This enormous loss is usually never traced to the right source—poor oil storage. The same criticism can be made of improperly stored paint oils, varnishes, dryers, etc. Competition in practically all lines demands economical production—that means elimination of waste so far as possible in every department of the industry.

Your oils, etc., can be checked as they are received and accurately recorded as arrived at.

they are used. You can keep just as accurate account of your oils as you can of your tools.

All railroads, mines or manufacturing institutions maintain stockrooms for the purpose of receiving and distributing all of the supplies used by the institution. This is considered absolutely necessary in order to reduce losses and to maintain a cost system.

Money is invested in oils just the same as any other supplies, yet it is a known fact that in most institutions no record is maintained as to the quantities received or dispensed.

Industrial plants of all kinds, especially railroads, are experimenting continually to learn how the cost of lubricating can be reduced and methods improved, forgetting apparently to investigate the oil house of the store-room where the oils are stored and issued—the place where the percentage of loss is usually the greatest.

**T**HE installation of a modern storage system for oils, etc., need not necessarily imply the outlay of large sums. We have found this "big investment" idea on the part of men in charge of garage and industrial institutions has frequently prevented them from considering the purchase of equipment. It is not always necessary, or even advisable, to put in at one time all the equipment the management might feel would be needed ultimately. In many instances storage is provided for those oils or other liquids which most urgently require it. The balance of the equipment can be added as finances permit or exigencies demand.

Modern storage equipment for handling liquids is really divided into two general types. One for handling volatile liquids, such as gasoline, naphthas, paint oils and varnishes, and the other for handling non-volatile liquids such as lubricating oils.

The first of the two general types requires underground storage tank for gasoline or naphtha, and above-ground storage for the paint, oils and varnishes. This arrangement usually meets with the demands of the various state laws governing this type of storage. Where under-ground tanks are required they should be cylindrical in design. If made of galvanized steel, all seams and rivets should be carefully made and then soldered inside and out. If heavy metal is used, such as three-sixteenth steel or heavier weights as conditions or the capacity of the tank may make necessary, then all seams and rivets should be carefully caulked. Storage tanks for volatile liquids require special care in construction. A tank may hold water or steam pressure, but is often unfit for volatile liquid storage purposes.

Specially designed pumps of either measuring or non-measuring type are connected by pipe lines to tanks buried under-ground or inserted in the top of tanks for above-ground use. Accurate devices are provided on the measuring pumps for the delivery of desired quantities of liquid. Gear-driven meters may be added for the purpose of checking consumption. Locks are supplied on both types of tanks and on the pumps as well. This prevents unauthorized usage and theft.

Where a battery of individual units is used, barrel track and barrel drainers are employed in connection with small chain hoists. This makes it very easy to handle the barrels and drain them completely into the manhole of the tanks. This saves labor, time and liquid, and prevents the loss of liquid due to the return of it in barrels which have not been properly drained by the old style spigot method. Dust, dirt and sediment are kept from the liquids, fire danger is entirely eliminated, valuable storage space is saved, labor is lessened, and cost and consumption are easily ascertained.



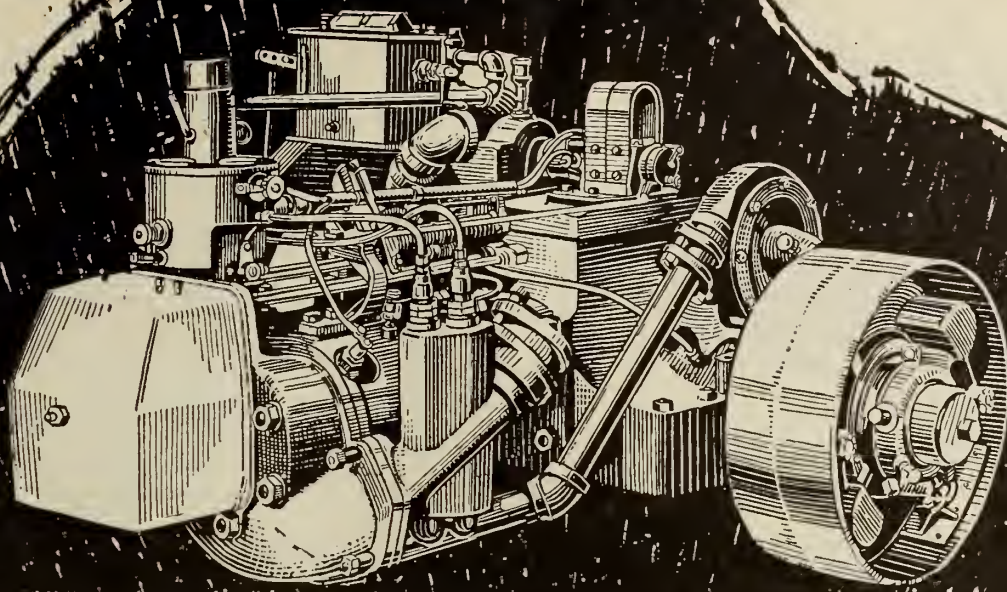

The 12-20  
Oil Pull Motor

## The Oil Pull Motor Demonstrates Oil Pull Quality

Oil Pull Quality—proved by the remarkable 10-year Oil Pull Record of Performance—is well demonstrated by the Oil Pull motor, the finest tractor motor in the world.

This is a broad statement—but it is amply borne out by the facts. The Oil Pull motor possesses more genuine quality in materials and workmanship than many of the finest automobile engines. It is the type of tractor motor that has proved the most efficient and durable in public and private tests for the past 10 years—two cylinder, low speed, heavy duty, valve-in-head.

And these are the outstanding features of this Oil Pull motor:—

—it is built complete in Advance-Rumely factories.

—it stands absolutely alone for fuel economy—especially built for fuel oils and guaranteed in writing to operate successfully on kerosene under all conditions.

—it follows automobile practice in machining—37 motor parts, including the cylinders, are ground to the thousandth part of an inch.

—it is the only oil cooled tractor motor—unaffected by extremes of heat and cold.

—its crankshaft is built to U.S. naval specifications—80,000 pounds tensile strength as against the usual 50,000 pounds.

—it is throttle governed—the speed of the engine automatically and instantaneously adjusted to meet changes in the load.

—the belt wheel runs directly off crankshaft—no intermediate gears—clutch operates from driver's seat.

—it employs a fresh oil system of combined force feed and splash—equipped with Madison-Kipp lubricator.

—it is equipped with a Bosch High Tension Magneto, the best and most expensive magneto made.

—all moving parts, including governor are enclosed.

—all parts are easy of access.

The Oil Pull is made in four sizes—12-20, 16-30, 20-40 and 30-60 H. P.—standard in design. They are oil cooled, oil burning and are backed by a written guarantee, and these exclusive features together with the high quality of its motor makes the Oil Pull a most satisfactory tractor from every angle for the dealer.

**ADVANCE-RUMELY THRESHER COMPANY, Inc.**

Calgary, Alta. La Porte, Indiana Regina, Sask.  
Saskatoon, Sask. 48 Abell Street, Toronto, Ont. Winnipeg, Man.

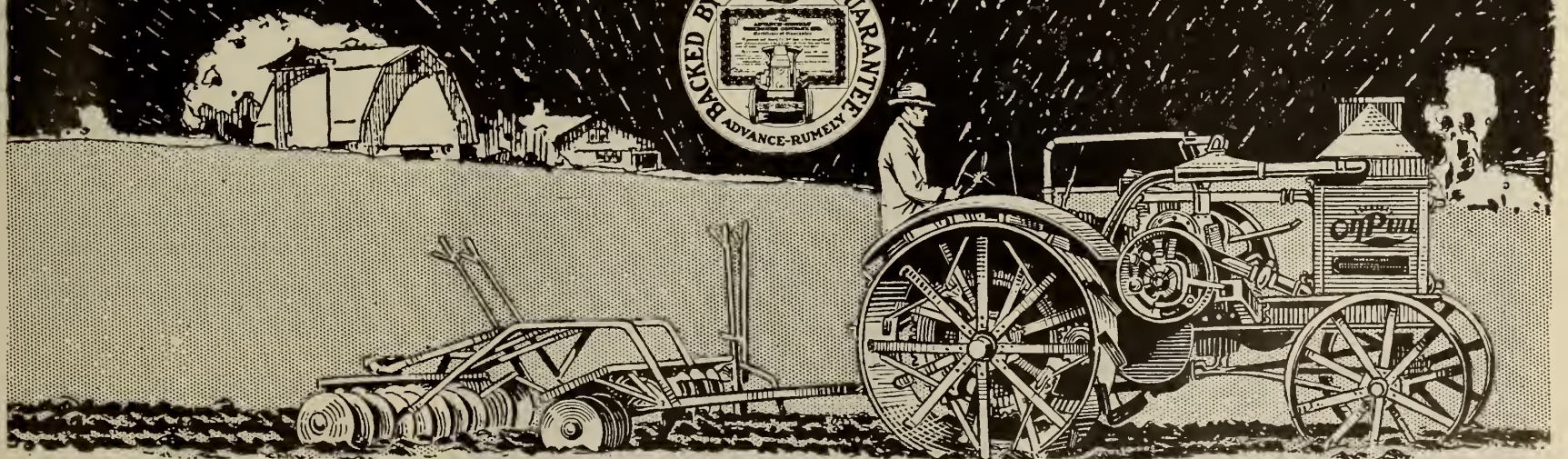

# ADVANCE-RUMELY



# POWER FROM A HOME PLANT

By ETHYL MUNROE

ONE OF the secrets of getting mechanical power with all the incidental comforts and labor-savers in the farm home, is to be able to make the power plant pay for itself in the work of the farms. This is why houses with electric lights and bath-rooms and power-washers are more general in dairy districts than in the straight grain or livestock section—the dairyman needs power to run a dozen contrivances in the barn which the general farmer may be able to get along without—so the home has to wait.

The other promoter of mechanical power in agriculture is the mechanical ingenuity to make the plant do its maximum amount of work, to apply it to as many uses as possible. This has been carried out to a remarkable degree on the W. W. Ballantyne farm near Stratford. Norman Ballantyne would have made a first-class electrical engineer; instead of that he went to the Agricultural College as his father had done, with the result that they now run a combined engineering and farming business with rather notorious success.

The plant consists of a dynamo and storage batteries run by an engine which is primed with gasoline and fed on kerosene. This equipment is set up in a powerhouse half way between the house and the barn with wires running to both buildings. The batteries are air-cooled so there is no trouble with frost in cold weather. There are two motors in the barn of one-half and one-quarter h.p., and a one-quarter h.p. motor in the house. At the barn the current operates the milking machine, and cream separator for seventeen or more pure-bred Ayrshire cows. The milking machine has given entire satisfaction. Between milkings the tubes are kept in a chloride of lime solution with clear water pumped through just before they are used. The motor that runs the cream separator in the milk-room can be moved to the barn floor to turn the fanning mill. The motor operating the milking machine also runs the emery wheel, pulps the roots and pumps the water—There are individual drinking cups throughout the dairy stable. For the heavier work, threshing, silo-filling and grinding they use a tractor. Mr. Ballantyne considers this plan more economical than using a heavier power plant for everything. And of course, all the buildings are lighted. This, in itself, they consider worth the cost of the plant on a dairy farm where during a great part of the year a certain amount of work must be done before daylight and after dark, especially since it has been necessary to get along with little help.

BUT modern equipment on this farm has not been confined to the barn and out-buildings. Mr. Ballantyne has always put conveniences in the home before or at least even with the farming

equipment. Before they had electricity on the farm they had a gasoline engine doing the washing, and pumping the water to the kitchen sink and the bathroom. When the electric plant was installed it was not necessary to change the old appliances. A motor was just belted to the shaft from which the pump and washer had formerly been operated. Later they bought a very up-to-date vacuum washer with a motor of its own. In the summer this is set up in a screened back porch or sun-room, a cool, airy place where the ironing and considerable other kitchen work can be taken on hot days.

The pump draws water from both the well and cistern, and as the water is heated by the kitchen stove in summer

room downstairs she would never have one upstairs, especially in a home where there are children. Another of her practical ideas is having a short length tub to economize in water in a dry season.

And if electricity has been applied to reduce the labor of the farm to a minimum, it is also being used to bring every modern comfort and convenience into the house. Every room, from the cellar up, is lighted of course. In the living rooms they have the indirect system with semi-transparent bowls giving a beautifully soft restful light. They have an electric iron and a vacuum sweeper—no more ironing by the heat of a hot kitchen fire in summer time, keeping fires going or waiting for irons



The Ballantyne home is a picturesque old house built on a slope of ground that gives a "basement entrance" on one side.

and the furnace in winter they have the advantage over most city homes in that they have hard and soft, cold and hot water on tap all the time. A system of taps is arranged so that in case of the soft water running low in a dry season they can draw from the well. It necessitated some remodelling to put in a bath-room. The house had been built in the days when bath-rooms were considered a luxury and altogether impractical for a country home, but the Ballantynes considered a bath-room one of the necessities in their house, and installed a complete equipment even when they had to use a hand force pump to pump the water. There is no attic in the house and the ceilings are too low to allow sufficient gravitation from a tank in the house to a bath-room upstairs, so they made a bath-room downstairs. It opens from the hall close to the stairway and Mrs. Ballantyne says that knowing the convenience of a bath-

to heat; no more heavy sweeping of carpets and stirring the dust about the room or even dusting walls, curtains and upholstered furniture, for the vacuum sweeper has special brushes to do all that. An electric toaster goes on the table every morning as regularly as the coffee pot, and a grill is ready to cook a quick meal or make a special hot dish when no other fire is needed. They even have a violet ray generator with all the sundry attachments that belong.

NOT the least item of interest about an equipment of this kind is the cost. The plant would now cost about \$750. The running cost is surprisingly low. The cost of kerosene for the month of November a year ago was \$2. At this time the plant was pumping the water for the house and barn, milking seventeen cows and separating the milk, and running the washing machine and

vacuum cleaner. This being a dark month when lights were used for several hours every day at both the house and the barn, and when the washing machine and vacuum cleaner were being used more than usual in house-cleaning, the cost would naturally be something above the average monthly cost for the whole year. Other cost features that Mr. Ballantyne explained were that instead of paying a man to turn the cream separator for twenty minutes a day all year, it is done by electricity at a cost of one-half cent an hour. The same motor that operates the cream separator, runs the fanning-mill at a cost of less than a cent an hour.

The way he has cut down labor costs with other mechanical power is equally interesting. Take his plan of threshing for instance. They have their own threshing machine. It is a self-feeder with a straw-cutting box and blower, and a grain elevator which they made themselves. With this elevator the grain can be run through pipes as it is threshed to any bin in the barn. The machine is run by a tractor. This year they threshed with two men and two teams. They used the low basket or Western racks so a man loaded his own load and brought it to the barn where another man unloaded it into the thresher. With this one handling, the two men brought in the grain and threshed it in less time than it would have taken four men to draw it in and mow it away.

And the progressive spirit that has made so much of the use of mechanical power on the farm and in the house is shown in other lines, and has, evidently, always been with the family. There are a great many farms in Ontario, even where an ice supply is put in every year for the dairy, that have never had a refrigerator in the house. As long ago as the time of the Centennial Exhibition in 1876, some of the Ballantynes—obviously W. W.—brought home from the fair a refrigerator that has been in constant use ever since. This is set in the cellar pantry. Beside it a door opens into a cement-lined fruit closet with shelves filled with canned fruit and meat and vegetables. Mrs. Ballantyne has experimented for herself and become quite a specialist in this line. It comes from the same appreciation of the best in new ways that has prompted the building of a sun-room, the screening of the porch, and putting all the aforesaid essentials of modern convenience and comfort into an attractive old house.

Mr. Ballantyne is well known as a stock man. In 1909 the Federal Minister of Agriculture appointed him Chairman of the Swine Commission that went to Europe to study the swine and bacon industry. He has been a director of the Guelph Winter Fair for over twenty years and president for the past two years; also a director of the Canadian National Exhibition for eight years and chairman of the Dairy Cattle and Dairy Produce Committee for several years. He has also been president of their local fair board and of the County Farmers' Institute and for the past three years president of the Southern Counties Ayrshire Breeders' Club. On a recent judging trip he didn't know how he was going to write a letter home without his typewriter; and his wife says that when the letter came she didn't know how she was going to read it.

PENTICTON.—Early this spring, Messrs Darknell and Waddell, proprietors of the Triangle Motor Service, will move into their new building. It is of cement construction and is 60 x 100 feet, fully equipped with spacious show rooms, battery department, machine shop and welding department.



The vacuum sweeper at work—the sitting-room where Mr. Ballantyne had his desk and typewriter.



The electric washer set up in the screened back porch.



## Ontario Automobile and Garage Dealers' Annual Convention

THE third annual convention of the Ontario Retail Automobile Garage and Accessory Dealers' was held in the Merchants' Assembly Hall, College street, Toronto, on March 2, 3 and 4. S. H. Rowed of London, Ontario, president of the branch, was chairman of the convention.

On the opening day Claude Pearce gave a rousing address on "Co-Operation" and "Second-Hand Cars," which was enthusiastically received by those present. He said he started in second-hand cars two years ago with practically no capital, but built up a business in second-hand cars second to none in Canada. One of his strong points was always give a customer full value for what he pays for. Another point which he emphasized was that a man dealing in second-hand cars should not at the same time carry on a business in new cars.

Mr. Pearce cautioned his hearer to beware of liens on cars which they handle.

"Make sure that the dealer is good for the price of the automobile you are buying, as the law says that the last man you buy the automobile from must refund the price if there is any lien or defect in title to the car."

Addresses were also delivered on the first day by the secretary, W. C. Milles; F. P. Powellman, "Vulcanizing an Important Garage Feature," and H. B. Moore, "Cost of Doing Business."

ON THE second day President Rowed gave an address on "Organization." He stated that in Middlesex County the association is 90 per cent. strong, Oxford County 99 per cent. strong. J. A. Conner, of the Dominion Rubber System, addressed the convention on "Why the Tire Manufacturer Approves Trade Associations."

One of the most instructive and interesting addresses was given by J. M. Leary on the new Bankruptcy Act which comes into effect on July 1 next. Three things in the act were vital: (1), Compulsory liquidation, which is only possible at the present time in Quebec; (2), A debtor has the right voluntarily to file a petition for bankruptcy, and (3), Provision is made for discharge of debtor who becomes bankrupt under certain restrictions, one of which is that he has paid fifty cents on the dollar although the court reserves the power to consider special circumstances where less has been paid.

Mr. Leary pointed out that the act does not apply to wage-earners who earn \$1,500 a year or less, nor to farmers. If debtor is adjudged bankrupt all the property owned by him at present as well as any which he may afterwards acquire belong to the trustee for the creditors, and on the other hand, if he assigns voluntarily future property is not attachable by the creditors.

Trustees in the bankrupt estate will be appointed by the Government and they have to furnish adequate security for the protection of the creditors. His remuneration is fixed by the act at a rate not exceeding five per cent. on the money received, and a similar remuneration to the solicitor.

The husband or wife of a bankrupt will not rank on the estate until all the other creditors are paid in full.

HON W. A. McLean, Deputy Minister of the Public Highways, who followed Mr. Leary, gave a resume of

the Government's program on highways.

"There are 140,000 automobiles registered in Ontario to-day, and I expect there will be 250,000 within five years," declared Mr. McLean.

There are 42,000 miles of highway now in use in Ontario, he stated, 10,000 miles of which are slated for improvements. About 1,800 miles will be taken into the Provincial highway scheme.

"If we get the men and the material we will during the next five years spend ten million dollars annually upon the 42,000 miles of road. Good roads are essential to the self-respect of any Province or county," he concluded.

W. A. Pease of the Imperial Life, gave an address on "Business Insurance." He outlined the various forms of life insurance that were applicable to business men for the protection of their business.

Mr. Ferguson of London, at the morning session when discussing the second-hand car business, said:

"This year the consumer will come to you to buy a car, and there will be a shortage, which will give you a chance. The time will come, however, when the automobile dealers will have to get out to sell their cars, and that is the time the second-hand car will be a problem.

"Let the automobile dealers organize and let the owner sell his own used car. The old way you have to sell two cars to break even."

ON THE third day of the convention the officers for the ensuing year were elected.

S. H. Rowed was re-elected president; vice-president, J. J. Duffus, Peterboro; second vice-president, Claude Pearce, Toronto; treasurer, Roy Alexander, Strathroy; secretary, W. C. Miller, Toronto.

An address on the Workmen's Compensation Act was delivered by George A. Kingston, commissioner on the Workmen's Compensation Board. He called attention to accidents of a character that would not entitle a man to compensation from his employer. "If a man, for instance, in gasoline-besmirched clothes was burned while lighting his pipe, he would not be granted compensation."

A lively discussion on the sale of tires and accessories brought forth some illuminating points.

Sales by manufacturers to U. F. O. Co-operative Stores were condemned. It was contended that the dealer was the man legitimately entitled to sell to the consumer. Secretary Miller claimed that the competition of co-operative stores against regular dealers was "illegitimate."

Some twenty-five resolutions were passed, the most important being:

"That members discontinue buying American goods until such time as the exchange becomes normal again, and that any orders placed before spring be cancelled unless different manufacturers will agree to bear all exchange over 6 per cent."

Another resolution was in favor of daylight saving.

There were about 100 delegates present at the convention. It was decided to hold the convention again in Toronto next year.

**Mr. Dealer**  
are you taking advantage of it?

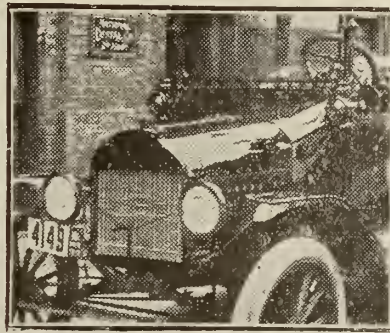

The demand for the Burrowes Patented de Luxe FORD CAR STREAMLINE HOOD is greater than ever.

Quick sales and big profits.

Fits Ford Cars previous to 1917.

Order in advance for prompt delivery or write for dealer's prices.

The Burrowes Mfg. Co., 611 King St. W., Toronto, Ont.

## It Is Profitable

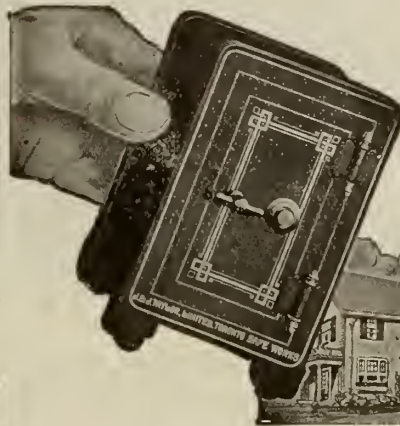

Pleasant and easy to convince people to provide adequate protection against loss of those papers and odd things of special value found in every home.

The "199" Taylor Safe Cabinet is a convincing argument to use, as it is not expensive, gives the maximum of safety against theft, and is fire-resisting.

Write us for terms to-day.

**J. & J. Taylor**  
LIMITED  
Toronto Safe Works  
TORONTO

Branches:  
Montreal Winnipeg  
Vancouver



## EXCLUSIVE FEATURES AT SEED-BED PREPARATION

No other tractor is so well adapted to this work as the GRAY. The Wide Drive Drum and wide front wheels distribute the weight so that no wheel marks or ruts are left in the seed-bed. The side hitch permits the easy hitching of all tillage tools,—discs, packers, harrows and cultivators.

You can also plow and do belt work. It is truly a general purpose tractor.

It also has a reputation for quality and a low repair record. It has proved itself over a long period of years. It is here to stay.

Dealers—we have territories open

Write for full information

**THE GRAY TRACTOR CO. OF CANADA, LIMITED**  
307-9 Electric Railway Chambers  
WINNIPEG, MAN.

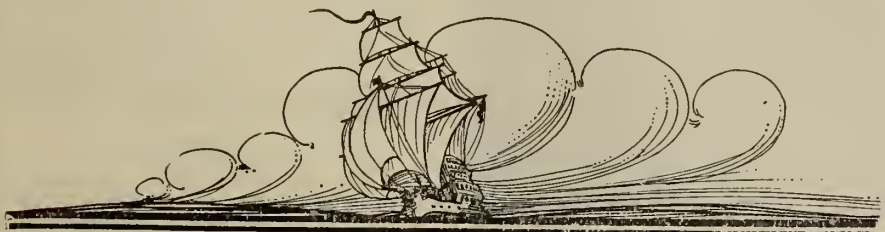



# THE INTERNATIONAL ROAD TOUR

**N**OVELTY is the great charm of motor car touring and the tourist will find the acme of novelty in scene and surroundings in 1920 International Good Roads Tour that traverses the great Northern Highway this summer. This new route, which extends from Toronto, through a portion of the mining districts of Northern Ontario and on through the great primeval forests of the Northland to Sault Ste. Marie, will be formally opened by the fifteen day tour which starts from Detroit, Mich., July 14, under the direction of the Michigan Pikes Association. The route for this tour will be from Detroit to Toronto, thence to North Bay, Sudbury and other Northern Ontario towns to Sault Ste. Marie and south to Detroit again, via Jackson.

A pathfinding trip was undertaken last autumn by representatives of the Detroit Automobile Club and the route was found excellent for touring, being most of the way over improved roads, while the few stretches of unimproved road are of a type that are good in the summer.

It is expected that the International Tour will open the way for thousands of tourists who will follow to see for themselves the scenic glories of Northern Ontario. The highway passes through the famed Muskoka Lakes region, which has for years been a resort for American and Canadian summer tourists, and into the highlands of Ontario. At Sudbury the wonderful Canadian mining region, with all its picturesque surroundings and incidents, is to be viewed. The stretch from Sudbury to Sault Ste. Marie is through a region of majestic woodlands, and in the farthest portion mountains of remarkable beauty are ever in sight. At the falls of the St. Mary's River one finds as beautiful a region as may be seen on the whole American Continent. Thence, to the south, the route is over a well-marked highway which has been improved in recent years by the State of Michigan and the different localities, the tour ending at the "Automobile Capital"—Detroit.

**A**N ADVANTAGE of the great Northern Highway is that the tourist returns by a different route and that it passes through parts of two countries of similar speech.

A complete housing equipment and commissary department, on nine trucks, all mounted on pneumatic tires will accompany the tourists. Road boosting meetings will be conducted in more than 300 Canadian and Michigan towns. It is expected that 40 cars and 200 good road enthusiasts will participate in the tour. Both Michigan and Ontario manufacturers of passengers and trucks will furnish the transportation.

## List of the Officials

The membership is made up of the business and professional men of the State of Michigan, and is not limited to the automobile industry or trade. The M. P. A. has the support of the automobile industry, the Michigan State Council of automobile clubs, the Detroit Automobile Club, the Detroit Auto Dealers' Association, and the Detroit Board of Commerce, in all its undertakings.

G. Edward Bliel, Detroit Republic truck distributor, is President; Fred. S. Case, Sault Ste. Marie, banker; State Senator H. A. Penny, Saginaw; and Fred. C. Westover, President Bay City Board of Commerce, are Vice-Presidents. Willard K. Bush of Detroit, an insurance agent, is Secretary, and Fred. E. Shearer, Bay City business man, is Treasurer. W. D. Edenburn, Automobile Editor of The Detroit News, is Tour Manager, and conducts the annual good roads' jaunt.

It is expected that a division of Ontario motorist, who will be similarly equipped with their own commissary, will join the tour either at London or Toronto.



A splendid stretch of good road in York County, Ontario

## KNOW THE MACHINE YOU SELL

**Y**OU can get more selling points on a machine by watching it in operation than any other way." This remark was made by an experienced implement dealer who went on to say that during his slack season he spent considerable time in the country following some of the machines he had sold.

"Back in 1904 I started in the implement business up in Minnesota. I did not know very much about the line I decided to sell, but the salesman assured me that I could get all the information needed out of the company's catalogues and instruction books. This sounded logical so I started in to 'brush up' on each tool.

"A few days after I had opened the store a farmer came in to look at the manure spreader I handled. Now that spreader was a first-class machine I knew, but there were three important

things about that spreader that I didn't know and which the instructive catalogues failed to give. Naturally that customer asked me the very things I didn't know and I had to own up that owing to my inexperience, he would have to try the machine out.

"He invited me to come along and see it work. I did. After two rounds I knew more about that spreader than I ever could have gotten out of the book. Then an idea occurred to me and I decided to carry it out. If there was so much to be learned about one machine why not spend some of my spare time in the field? This sounded good to me so all during the period when the farmer is mighty busy in the field and the implement dealer is enjoying the so-called 'cob-web' season by putting a polish on a chair seat, I profitably spent my time out in the country watching my machines with an ever increasing interest. If the work was satisfactory

the owner was not bashful in stating the good points of the machine and I soon found that by making mental note of these sales points, I had a knowledge of my goods that few dealers ever acquire.

"In addition to this, I was getting a grip on the goodwill of my customers that would be hard to break. They saw that I was just as much concerned in the work my machines were doing as I was in making the original sale. This fact alone brought me many sales that would otherwise have been made by my competitors in the next town.

"After three months of this kind of missionary work I found that the farmers in our locality were depending on me to give them advice, and soon I capitalized on the idea. The local paper ran my advertisement stating that my on-the-ground service was at the farmer's beck and call, day or night, and that I was as much interested in a machine after it was sold as before. Then mention was also made that the mail order house did not take care of the machines they sold while I was always nearby and ready to give them every assistance. This argument helped to counteract this class of business, and to-day I don't believe there is a farmer within twenty miles who buys any farm machinery from anyone besides myself."—*E. B. Magazine.*

## LENGTHEN LIFE OF THE VALVE.

**T**O lengthen the life of the valve, prevent noise and conserve oil, J. Moss, of Newmarket Garage, Newmarket, Ontario, conceived and has been practising for years the following scheme. Remove the plates on the Ford motor exposing the valves and valve springs; pack the space with a heavy cup grease and replace the plates. This, Mr. Moss asserts, will silence the motor, prevent the valve stems from wearing and the oil pumping up from the crank case, and being wasted. This was done on a Ford car in 1910 and—according to Mr. Ross—when the car was brought to him recently to have some slight repairs done, on examination and test by a micrometer, the valve stems shaved a variation less than 1-1000th part of an inch. Can you beat that?

## AN AUTO ANTHEM

Tune—*God Save the King.*

My auto, 'tis of thee, short road to poverty, of thee I chant. I blew a pile of dough, on you three years ago; now you refuse to go, or won't or can't. Through town or country side, you were my joy and pride, a happy day. I loved thy gaudy hue, thy nice white tires new, but now you're down and out for true, in every way. To thee, old rattle-box, came many bumps and knocks, for thee I grieve. Badly the top is torn, frayed are the seats and worn; the whooping cough affects thy horn, I do believe. Thy perfumes swell the breeze, while good folks choke and wheeze, as we pass by. I paid for thee a price, 'twould buy a mansion twice, now everybody's yelling "ice"—I wonder why? Thy motor has the grip, the spark plug has the pip, and woe is thine. I, too, have suffered chills, ague and kindred ills, endeavoring to pay my bills since thou were mine. Gone is my bank roll now, no more 'twould choke the cow, as once before. Yet if I had the mon, so help me John—I'd buy a car again and speed some more. Amen.



Characteristic scenery of Northern Ontario through which the big motor tour will pass

PORT ALBERNI.—W. Le Huray, proprietor of Port Alberni Garage, reports winter business very good and sees great prospects for summer sales.



# Stop That Rattle!

Silence every rattle with a Hold Tite Nut Lock

Simple, inexpensive, positive.

No vibration can loosen it.

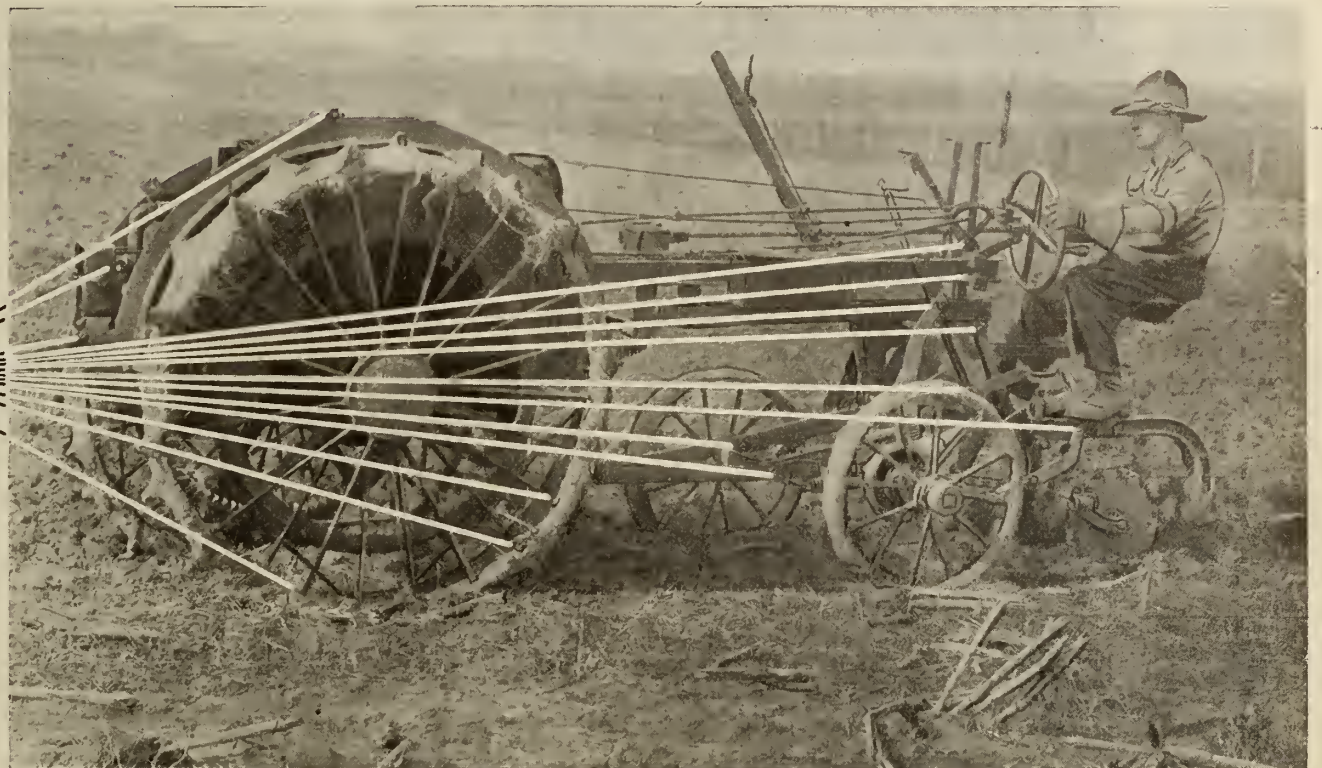

Simple Method of Applying

**FIRST**

Knowing the Size Bolt—  
Use Same Size Nut Lock  
Place Over Bolt — THIS WAY

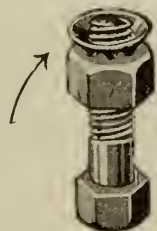

**SECOND**

Screw Another Nut Down  
onto Nut Lock and Depress It  
THIS WAY



**THIRD**

Remove Second Nut and  
Nut Lock will Lock  
THIS WAY



It's the outcry of a dozen malicious little demons that are gnawing at the heart of your automobile, your tractor, your farm implements.

The tongue of each is a loose bolt, and as it lashes it tells a tale of wearing parts and wasted power. Every grating rattle is the voice of an enemy.

## THE HOLD TITE NUT LOCK

destroys the little demon of wear and tear and safeguards the power you are paying for. When this little collar of steel is pressed into position each nut is snug and fast **for keeps**. The Nut Lock is proof against all the jarring and jolting of roughest roads and heaviest field work.

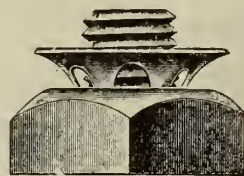

Low in cost because there is no waste material, supreme in efficiency by actual test under the most severe conditions, the Nut Lock is being adopted by manufacturers and sold by dealers everywhere.

Write to-day for full particulars.

**EDWARD A. ROBINSON CO., LTD.**

228 Craig Street W., Montreal

American Factory: 166 Montague St., Brooklyn, N.Y.

Some of the Satisfied Users of the Hold Tite Nut Lock

Canadian Pacific Railway Co., Montreal.

Canadian Vickers Co., Montreal.

Renfrew Electric Co., Renfrew, Ont.

Canada Cement Co., Montreal.

Packard Electric Company.

Gray and Davis, Inc.

Electric Auto-Lite Corp., Toledo.

Grandall Packing Co., Boston, Mass.

Dominion Oilcloth Co., Montreal.

Montreal Tr a m-ways.

Canadian Transfer Co., Ltd., Montreal.

Northern Electric Co., Ltd., Montreal.





# BIG ADVANCE IN CAR PRICES

## A List of Some of the Cars Handled in Canada

THE following table shows the comparative prices of the 1919 and 1920 models. In each case the price quoted is F.O.B., Toronto. The advance in price ranges from \$50 to \$1,500—due to the scarcity of ma-

terial, increased cost of labor, rising exchange and improvements in the new models. In some cases the improvements have been extensive—all round cord tires introduced in place of the

fabric; wheel base lengthened, change in body design, etc., etc.

There is nothing to indicate that the prices will take a drop. On the contrary there is every evidence of still more increases in the near future.

Car	Model	Price 1919	Price 1920	Increase	Car	Model	Price 1919	Price 1920	Increase
ALLEN	Roadster	\$ 1,875.00	\$ 2,475.00	\$600.00	MOON	5 Pass. Touring	\$2,885.00	\$3,285.00	\$400.00
	Sedan	3,475.00	3,475.00	no increase		" Sedan	4,285.00	4,685.00	400.00
AUBURN-BEAUTY SIX	Coupe	1,640.00	1,740.00	100.00	" Coupe	4,285.00	4,685.00	400.00	
	Sedan	2,170.00	2,270.00	100.00	7 Pass. Touring	3,595.00	3,995.00	400.00	
	Special	1,510.00	1,600.00	90.00	" Sedan	5,050.00	5,450.00	400.00	
	Standard	1,375.00	1,475.00	100.00	" Coupe	5,050.00	5,450.00	400.00	
BRISCOE	Roadster	2,800.00	2,900.00	100.00	McLAUGHLIN	K-62	1,625.00	1,735.00	110.00
	Touring	2,719.00	2,819.00	100.00		K-62 Special	1,700.00	1,810.00	110.00
	Sedan	4,400.00	4,400.00	no increase		K-63	1,625.00	1,735.00	110.00
	Coupe	4,400.00	4,400.00	no increase		K-63 Special	1,700.00	1,810.00	110.00
CHALMERS	Touring	2,400.00	2,550.00	150.00		K-44 Ex-special	2,265.00	2,350.00	85.00
	Roadster	2,400.00	2,550.00	150.00		K-45 Ex-special	2,265.00	2,350.00	85.00
	Coupe	no model	3,760.00	.....		K-49	2,655.00	2,760.00	105.00
	Sedan	no model	3,970.00	.....		K-46 Coupe	2,905.00	3,010.00	105.00
	Seven Passenger	2,550.00	2,750.00	200.00		K-47 Sedan	3,340.00	3,450.00	110.00
CHANDLER	Touring	2,950.00	3,150.00	200.00		K-50 Sedan	3,910.00	4,065.00	155.00
	Roadster	2,950.00	3,150.00	200.00	K-62 Coupe	2,395.00	2,445.00	50.00	
	Dispatch	3,150.00	3,350.00	200.00	K-63 Sedan	2,555.00	2,610.00	55.00	
	Coupe	4,375.00	4,575.00	200.00	OLDSMOBILE	Touring	2,925.00	3,150.00	225.00
	Sedan	4,500.00	4,700.00	200.00	PACKARD	Touring	8,400.00	8,625.00	225.00
CLEVELAND	Touring	2,185.00	2,385.00	200.00		Limousine	10,800.00	11,090.00	290.00
	Roadster	2,185.00	2,385.00	200.00		Sedan	11,000.00	11,295.00	295.00
	Coupe	no model	3,600.00	.....		Pass. Runabout	no model	8,625.00	.....
	Sedan	no model	3,600.00	.....		4 Pass. Phaeton	" "	8,625.00	.....
					Duplex Coupe	" "	11,295.00	.....	
COLE	Roadster	4,500.00	4,750.00	250.00	PAIGE	5 Pass. Touring	2,400.00	2,875.00	475.00
	Touring	4,500.00	4,500.00	no increase		" " Roadster	2,400.00	2,875.00	475.00
	Sedan	6,600.00	7,150.00	550.00		5 Pass. Sedan	no model	4,175.00	.....
FORD	All Models fully equipped					" " Coupe	" "	4,000.00	.....
	Runabout	\$ 743.17	\$ 810.00	\$ 66.83		7 Pass. Touring	3,200.00	3,800.00	600.00
	Touring	770.70	840.00	69.30	" " Sport	3,350.00	3,925.00	575.00	
	Coupe	963.17	1,050.00	86.83	" " Sedan	4,675.00	5,300.00	625.00	
	Sedan	1,143.87	1,250.00	103.13	" " Coupe	4,675.00	5,150.00	475.00	
FRANKLIN	Sedan	6,000.00	6,000.00	no increase	REO	Touring	2,660.00	2,760.00	100.00
	Brougham	5,925.00	5,925.00	no increase		Roadster	2,660.00	2,760.00	100.00
	Touring	4,400.00	4,400.00	no increase		Sedan	4,150.00	4,150.00	no increase
	Five Passenger	4,325.00	4,325.00	no increase		Coupe	3,975.00	3,975.00	" "
	Four Passenger	4,400.00	4,400.00	no increase		STANDARD 8	Roadster	4,850.00	Price not fixed
					4 Pass.	"	"	"	
GRAY-DORT	Ace	1,695.00	1,795.00	100.00	7 Pass.	"	"	"	
	Coupe	2,475.00	2,475.00	no increase	Coupe	6,800.00	"	"	
	Roadster	1,425.00	1,525.00	100.00	Sedan	6,650.00	"	"	
	Standard	1,425.00	1,525.00	100.00	Limousine	6,950.00	"	"	
HUPMOBILE	Touring	2,275.00	2,480.00	205.00	STUDEBAKER	7 Pass. Touring	3,225.00	3,300.00	75.00
	Roadster	2,275.00	2,480.00	205.00		5 Pass. Touring	2,515.00	2,665.00	150.00
	Coupe	no model	3,600.00	.....		Coupe	3,600.00	3,800.00	200.00
LEXINGTON	Touring	3,060.00	3,250.00	190.00		Sedan	3,700.00	4,100.00	400.00
	Sporting	3,060.00	3,250.00	190.00		Roadster	2,515.00	2,665.00	150.00
	Sedan	3,750.00	3,850.00	100.00	VELIE	Touring	.....	2,675.00	.....
MAXWELL	Touring	1,390.00	1,590.00	200.00	Roadster	.....	2,675.00	.....	
	Roadster	1,390.00	1,590.00	200.00	Sport	.....	2,925.00	.....	
	Sedan	no model	2,650.00	.....	Coupe	.....	3,975.00	.....	
	Coupe	no model	2,550.00	.....	WESCOTT	Roadster	2,940.00	3,410.00	470.00
						Touring	2,940.00	3,410.00	470.00
				Coupe		no model	4,710.00	.....	
				Sedan		no model	4,975.00	.....	
				A-48 Touring		3,875.00	3,975.00	100.00	
				A-48 Sedan	4,875.00	6,375.00	1,500.00		



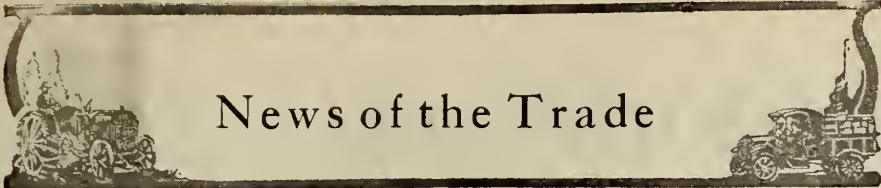

## News of the Trade

**BRITISH COLUMBIA**

**CLOVERDALE.**—H. A. McDonald has secured the agency for the Overland car.

**EDMONTON.**—J. W. Freeman has sold his automobile business to McAllister and Cimby.

**ARMSTRONG.**—A. Smith & Son have purchased the automobile business of D. C. Leavy.

**NEW WESTMINSTER.**—A new garage has been opened on Columbia Street by Goodwin Bros.

**PARKSVILLE.**—Rushton Bros. have started work on the erection of their new 50 x 30 ft. garage.

**VANCOUVER.**—The Auto Supply Co., a tire concern, has been succeeded by the Morley, Pauline Rubber Co.

**ABBOTSFORD.**—A. McPhee is now operating the implement business formerly conducted by J. P. Firlotte.

**UNION BAY.**—Geo. Neill is erecting a new garage and salesroom. He will handle autos, accessories and repairs.

**COURTENAY.**—Frank H. Cucksey, proprietor of the Courtenay Garage, has secured the Overland and Chevrolet agencies.

**VERNON.**—J. H. Watkins has erected a new garage 50 x 100 feet of brick construction, and will move into it early in March.

**HOPE.**—A. B. Lloyd has opened the Hope Garage and Jitney Service. He handles accessories, tires, gasoline, oils and greases.

**NORTH VANCOUVER.**—Good business in accessories and repairs is the report of Gibbs Bros. of the Ford Service Station.

**NEW WESTMINSTER.**—The death is announced of John McClughan, of the firm of James and McClughan, automobile dealers.

**CLOVERDALE.**—The Traffic Truck agency has been secured by Hamre and Carmichael. They handle repairs, accessories, tires, gasoline and oil.

**LANGLEY PRAIRIE.**—W. DesRochers, formerly of Ashcroft, has opened a vulcanizing plant here. He will also carry a line of accessories.

**PARKSVILLE.**—The Parksville Garage, which has been closed up for the past two years, has recently been opened by Harbour and Martindale.

**MISSION CITY.**—A new garage was opened here recently by the Plumridge Motor Co. They handle Overland cars, Traffic trucks, vulcanizing and repairs.

**COURTENAY.**—Emde and Wain, dealers in Ford and McLaughlin cars, report business good in 1919. They sold 60 Fords and 16 McLaughlins from June 1 to Dec. 31, 1919.

**VERNON.**—H. B. Monk, formerly of the R. F. C., is now a partner in the Vernon Garage. He has recently completed arrangements to take charge of aeroplane repairs—this being special work taken on by the Vernon Garage.

**NORTH VANCOUVER.**—The North Shore Garage, operated formerly by Gamage and Co., is now controlled entirely by Ed. Gamage. "Ed" is planning some extensions among which will be a new battery service station.

**CHILLIWACK.**—Messrs. S. C. Partlo and F. G. Edwards have recently opened a new garage under the name of the Chilliwack Garage. They have secured the agency for Overland cars and handle repairs and accessories.

**ABBOTSFORD.**—Geo. R. Wright and F. W. Johnson, proprietors of the Abbotsford Garage, are enlarging their premises. The new extension will include showrooms, rest-rooms for tourists and welding and machine shop.

**CHILLIWACK.**—A. K. Humphrey and H. A. Crocker, proprietors of the Valley Vulcanizing Co., have almost completed the erection of a new plant, 30 x 44. They do all vulcanizing repairs and handle accessories and gasoline.

**MERRITT.**—J. P. Boyd, proprietor of the Nicola Valley Garage, is erecting a new show room 50 x 60 feet and enlarging his stock of accessories and repair parts. He is installing a battery repair equipment, welding and vulcanizing plant.

**COURTENAY.**—Owing to their rapidly expanding business, N. A. Goddard and A. J. Willemar, proprietors of the Courtenay Vulcanizing and Welding Works have found it necessary to seek larger quarters. They are now settled in their new premises on Courtenay Road, where they are doing a big business in Hupp and Briscoe cars and traffic trucks.

### STRINGENT REGULATIONS PLANNED IN MANITOBA REGARDING SALE OF FARM IMPLEMENTS

STRINGENT regulations respecting the sale of farm implements are included in a bill which received its second reading in the Provincial Legislature by the Minister of Agriculture.

The bill provides that no dealer shall misrepresent his goods with the penalty of being forced to return the money for such articles as he misrepresents. The bill also provides that no second-hand material shall be used in manufacture of implements.

Following are the amendments: "All implements sold by implement dealers shall be deemed to have been sold upon the representation that such implement was a new implement and if any implement or any part is discovered to be second-hand, used or rebuilt, the purchaser, may at his option, return the implement and receive back money paid on account of same, together with interest, and the sale shall be cancelled.

"Should any representation or statement as to what any machine or implement will do, or as to what its capacity is, be made by any machine company or machine agent in advertising matter, pamphlets, literature, letters or circulars whether the same has been seen and acted upon by the purchaser or not or to such purchaser verbally prove to be untrue, the purchaser may at his option return the implement or machine and receive back money paid on account of same together with interest, and the sale shall be cancelled."

### AUTO CLUB PRESIDENT DIES AT MONTREAL

M. J. STACK, president of the Montreal Automobile Association, died at his home in Montreal on Monday last after a brief illness.

The late Mr. Stack was only 42 years of age and had taken an active interest in recent years in automobile matters. He was president of the Montreal Automobile Association, and had taken a considerable interest in the building up of the Quebec Highway. He had also been interested in the construction of the underground wiring system at Verdun, Que., and in his business as a contractor was more recently engaged in building St. Augustine's Church in Notre Dame de Grace. He was president of St. Patrick's Society and a member of the Knights of Columbus and of the Rotary Club. He is survived by his wife and three children.



# SALE OF MILITARY AND OTHER GOVERNMENT STORES

Equipment and Supplies for Hospitals, Institutions, Bunkhouses, Camps, Dining-rooms, Kitchens, etc.

Bedsteads, Furniture, Hardware, Dry Goods, Rubbers, Overshoes and other Footwear, Blankets, Sheets, Pillows, Baskets, Woodenware, Brushes, etc.

CONSTRUCTION EQUIPMENT AND MACHINERY—AMBULANCES

The Stores are located at various places throughout Canada

Instead of or in addition to sales by sealed tender

## PRICE LISTS WILL NOW BE ISSUED

for most articles—the goods being offered in lots for purchase by wholesale houses, jobbers, and the trade generally.

## TRADE ONLY SUPPLIED

except that arrangements previously announced for sale to returned soldiers and sailors and widows and dependents of same through the G.W.V.A. and similar organizations and to hospitals and philanthropic institutions will be continued.

**SALES WILL CEASE IN MARCH.** Any balances left will be cleared by public auction shortly thereafter. This advertisement will not be repeated. Those interested should therefore apply **AT ONCE** for price lists and other information to the . . .

**SECRETARY OF THE WAR PURCHASING COMMISSION,  
BOOTH BUILDING, OTTAWA**

February, 1920



# Automotive Accessories and Implement Equipment

## SIGNAL TAIL LIGHT

THE Signal Tail Light manufactured by the Grand Rapids Brass Company of Grand Rapids, Michigan, is designed and built to eliminate the necessity of confusing arm extension to signal the driver behind to stop. As rear end colliding is an ever imminent source of many serious mishaps it is essential that the driver behind be intelligently signalled so he, too, will know exactly what to do.

A very important feature of this signal tail light, say the makers, is its 2½-inch controlling disc that attaches right to the steering wheel which enables the driver to signal without removing hands from the wheel and keep his undivided attention on the roadway ahead. The decisive signals, STOP—LEFT—RIGHT—BACK are instantly flashed, appearing in a 10-inch by 3½-inch rear Signal Tail Lamp.

It is operated by electricity from battery or cells; is water-proof, dust-proof and fool-proof and can be quickly installed to any make of car by means of a universal bracket. When the car is moving forward, only a red tail light warns the driver behind.

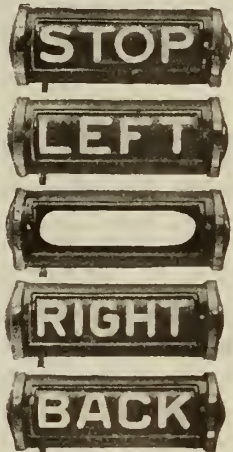

Signal Tail Light

## RELIABLE BATTERY FILLER

THE Reliable Mfg. Co., Cleveland, Ohio, have put on the market a battery filler for use in the service station. The makers say it is strong and of heavy construction for long service. It fits any one gallon bottle and no metal comes in contact with contents, and is dust proof. The device provides a convenient means of filling batteries, either with distilled water or electrolyte.

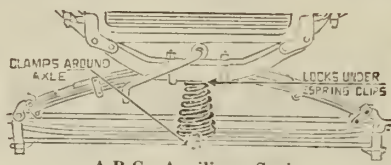

A.R.G. Auxiliary Spring

## U.S.L. ARC WELDER

THE USL Arc Welder is a variable voltage type of machine of exclusive design for generating 200 amperes, or less, direct current at the voltage range required for arc welding. The equipment is intended for single operator use and comprises a motor generator or a converter, a switch and meter panel, an arc stabilizing reactor, an electrode holder, a face shield and for portable use a truck and cable reel with two fifty foot lengths of flexible cable.

The USL Arc Welder may be adjusted to have either a constant energy or constant current tendency throughout the welding range. There is no danger from shortcircuiting the welding circuit. A strong, steady arc is maintained without sputtering, spotting or sticking; an arc which penetrates the weld so as to make the metal fuse perfectly; which when broken leaves no pitting, maintains a constant heat and steady flow of metal into the weld, and produces a solid, homogeneous, reliable weld.

To enable the operator to vary the current to meet his requirements USL Arc Welders are equipped with both a voltage adjusting rheostat and a current adjusting switch.

The truck on which the welder is mounted is supplied either with or without cover, cable reel and cable. It is 28 inches wide, 55 inches high and 54 inches long. The truck is so constructed that one man can move it over rough shop floors with ease. The outfit is built by the U.S. Light and Heat Corporation, Niagara Falls, N.Y.



Yankee Creeper

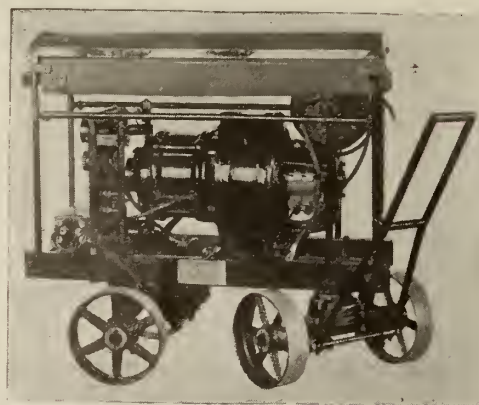

USL Arc Welder.

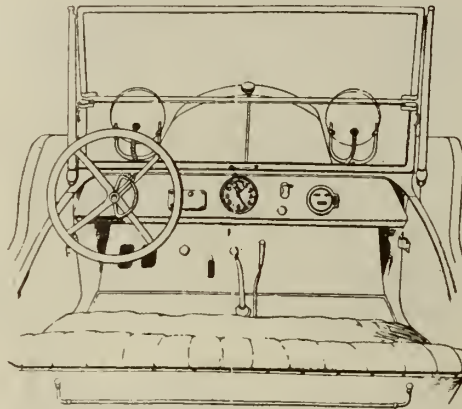

Auto Automatic Lite



Van Siefken Speedometer



Reliable Battery Filler.



Bulldog Clip

## A. R. G. AUXILIARY SPRING

THIS spring is designed for Ford cars and is manufactured from a high-grade of steel. It has a special patented plate at the top which locks under the spring clips; another plate clamps on the bottom and ties to the axle by a clip. This forms a combination shock absorber and spring protector, say the makers, and in addition gradually reduces the rebound of the front spring so as to eliminate the sudden jar or "buck."

It is made in two sizes—light and heavy—and can be installed in a minute. The manufacturers are the A. R. G. Auxiliary Spring Co., Inc., Birmingham, Ala.

## VAN SIEKLEN SPEEDOMETER

THE Van Siefken Speedometer Co., Elgin, Ill., has put on the market a new speedometer known as No. 134. It is designed specially for the Ford Sedan and Coupe which are being supplied with a metal covered board. This new equipment, the makers say, is expected to supersede all others that they have made.

A special cutting tool has been made for boring through the metal covered board, facilitating the installation of the speedometer.

## BULLDOG CLIP

THE Bulldog Clip has been designed for use in connection with charging batteries. The clip is 3¼ inches long, ⅝ inch wide and .052 inch thick. The sliding sleeve is 7/16 inch wide and .035 inch thick. There are no springs or screws. The deep saw tooth jaws dig into the lead, assuring positive contact. The contact member is stepped and gives four adjustments. The minimum resistance current enters at sleeve instead of at top contact member. The clip is anti-corrosive and heavily lead coated. It is made by Reliable Mfg. Co., Cleveland, Ohio.

## YANKEE CREEPER

THIS creeper is made with a springy reinforced sheet-metal body, with tool trough on each side convenient and accessible. The head rest is of heavy webbing, swung hammock-like across full width of the body. It is fitted with extra large ball-bearing casters, is 40 inches long, 16 inches wide and weighs 12 pounds. It is finished in black enamel. The manufacturers are the International Metal Mfg. Co., Philadelphia.

## AUTO AUTOMATIC LITE

THIS device is designed for automatically lighting up automobile dimmer and tail lights. It consists of a clock connected to the lighting system by two short flexible wires. It works on the system of an alarm clock and only requires winding every eighth day. The makers say it is simple, durable and dependable; is easily regulated to give service for any hour or fraction thereof. It is only necessary to set the clock to the required lighting up time and whether you are near your car or not when darkness sets in, the lights will be automatically switched on. It is manufactured by Hayes Mfg. Co., Racine, Wis.



# ALLIS-CHALMERS TRACTORS

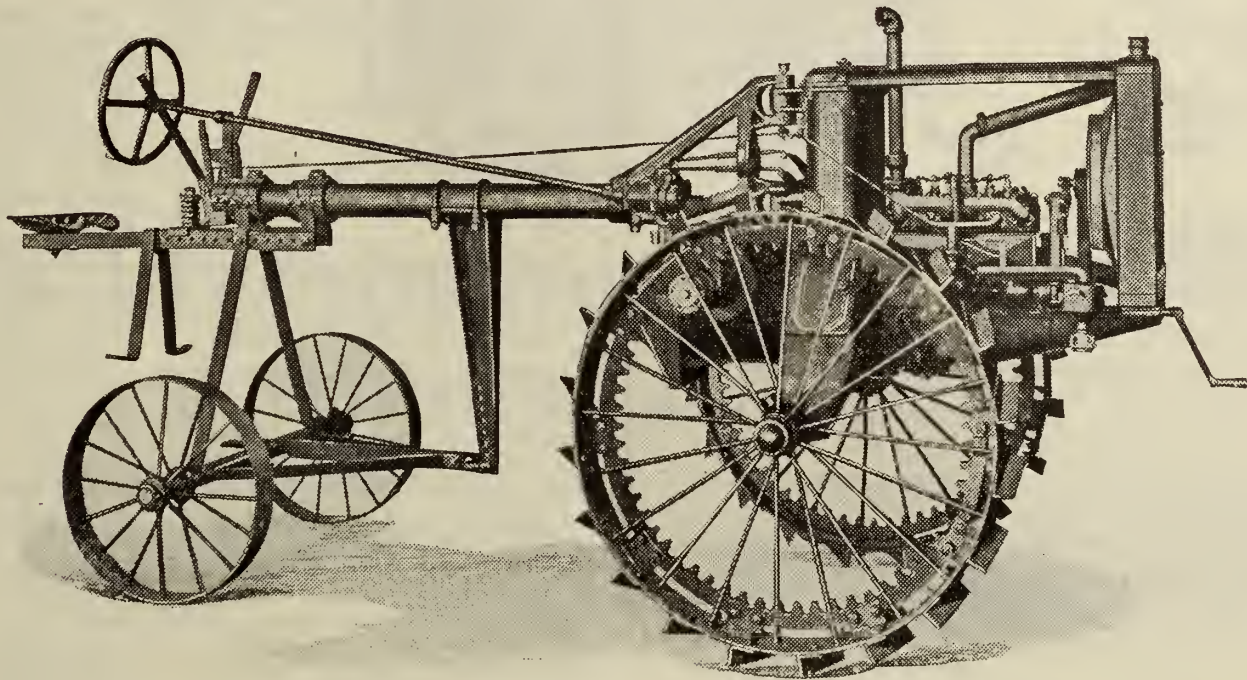

## THINGS EVERY TRACTOR DEALER SHOULD KNOW

You are making up the lines you will handle. Be sure that the connection you make will prove a satisfactory one.

**Look for Business Reputation.** The Canadian Allis-Chalmers Limited and the Allis-Chalmers Manufacturing Company have been known throughout Canada for 65 years as one of the largest manufacturers of quality machinery in the world.

**Look for Manufacturing Ability.** The huge Allis-Chalmers plants, equipped with the most modern machinery, are ready for quality production on a quantity basis.

**Look for Tractor Value.** Study every detail of design—don't be sold on sales talk—see with your own eyes—over \$3,000,000.00 have been spent in perfecting Allis-Chalmers Farm Tractors.

**Look for Adaptability.** Two models are offered to you—the 18-30, a big 4-plow tractor, and the 6-12 General Purpose, a one-man tractor that may be used with any standard implement already on the farm requiring 4 horses or less.

## CANADIAN ALLIS-CHALMERS LIMITED

Head Office: 212 King West, Toronto



## THE BEST BUMPERS OBTAINABLE

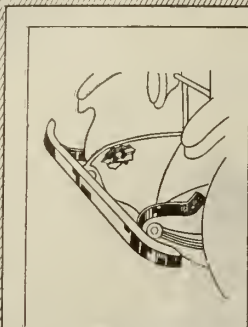

"KABEE"  
SPRING ARM CHANNEL  
BUMPER

"LYON"  
RESILIENT BAR  
BUMPER

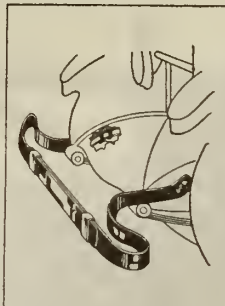

DURABLE BRILLIANT FINISH  
PATENTED "HOOKBOLT" ATTACHMENT  
FITS 90% OF STANDARD CARS  
OBTAINABLE FROM JOBBERS & DEALERS  
CATALOGUE ON REQUEST

**KINZINGER BRUCE & CO. LTD.**  
NIAGARA-FALLS, CANADA  
SOLE MANUFACTURERS, UNDER  
LYON CANADIAN PATENTS.

## NEWS — OF THE TRADE FOR THE TRADE

### MARITIMES

CHARLOTTETOWN, P. E. I.—The Automobile Dealers' Association have decided to hold a motor show in the Armouries on March 16-17.

POPIOK, N. B.—The roof of the Central Garage, owned by Elliott and Caverhill, collapsed recently and slightly damaged some automobiles, which were stored therein. The heavy snow-falls of the past two weeks caused the collapse.

### QUEBEC

MONTREAL.—The Tourists' Bureau of Montreal, promoting Metropolitan and Quebec tours, is compiling a complete folder and map of the city for free distribution.

MONTREAL.—It is expected that the White Motor Truck Company, of the United States—who, it is rumored, contemplate manufacturing the product in Canada—will locate in Montreal.

MONTREAL.—The Lexington Motor Sales, Limited, of 27 McGill College avenue, have secured the agency for the Veteran truck. This truck is built by The Eastern Canada Motor Truck Company, Limited, of Hull, P. Q.

MONTREAL.—The Weekly Post Card Bulletin, which is mailed to the members of the Montreal Automobile Association, will begin the 1920 series on May 20, and continue weekly to October 20. A special feature will be made of speed traps, road detours, etc.

### ONTARIO

TORONTO.—Joseph Van Sickler has applied for a permit to erect a \$35,000 public garage on Dupont street.

KINGSTON.—Kingston is considering the purchase of a two-piece motor apparatus for the Fire Department.

SARNIA.—The Wills-Lee Auto Corporation has purchased the Sarnia Indian Reserve site, and will erect a three million dollar Canadian plant.

TORONTO.—The annual convention of the Ontario Retail Automobile Garage and Accessory Merchants' Association was held on March 2, 3, and 4.

TORONTO.—The Guide Motor Lamp Co. has purchased property on Jarvis street and will immediately erect a modern four-storey warehouse and factory building.

CHATHAM.—The Chatham Auto Motor Dealers' Association will hold an automobile show in the Armouries from March 17 to 20. R. M. Jeffrey of Windsor, will be the manager.

GUELPH.—J. H. McNally, automobile dealer, will erect an up-to-date garage on Macdonald street. The new garage will be a two-storey structure and will cost in the neighborhood of \$40,000.

LONDON.—Ald. F. E. Harley at a recent session of the City Council introduced a proposal to issue debentures for the purchase of motor busses to be operated by the municipality in competition with the trolley cars.

TORONTO.—G. E. Gooderham, Chairman of the Hamilton Highway Commission, announced recently that next winter the commission would operate large snow-plows, drawn by motor trucks, on the highway.

TORONTO.—Hon. F. C. Biggs, Minister of Public Works, at the Sixth Annual Session of the County Roads Superintendents and Engineers, recently, said that trucks will do the road construction of the Province in the future.

TORONTO.—The Republic Motor Car Co. will build a new garage and service station on the south side of St. Albans, near the corner of St. Vincent street. The building will be two storeys high and of brick and concrete construction.

OSHAWA.—Geo. Rice, elevator operator at the Chevrolet Motor Company, was made the recipient of a fifty-dollar cheque, for displaying presence of mind in promptly reversing the elevator and thereby saving the life of Wm. Fox.

### MANITOBA

WINNIPEG.—Messrs. Pearce and Bickell, of the Standard Machine Works, have added to their automobile repair department a new Heald Cylinder Grinder.

WINNIPEG.—Motorists of Winnipeg are discussing organization of a club of automobile owners for the purpose of boycotting gasoline until the price is forced down.

WINNIPEG.—The seventh annual Canadian Good Roads Convention will be held this year at the Royal Alexandra Hotel, Winnipeg on June 1, 2 and 3. This will be the first time the convention has been held in the West.

WINNIPEG.—The Lauson tractor, made by the John Lauson Mfg. Co., New Holstein, Wis., will be distributed in Western Canada by the Bushman Motor Works, Ltd. The Saskatchewan Lauson Tractor So., Saskatoon, and the McCleneghan & Taylor Co., Lethbridge, Alta., who have been handling the Lauson for some time, will work hand in hand with the Bushman people. A E. Donovan is manager of the Bushman concern.

WINNIPEG.—Greater Winnipeg Water District Board refused to consider the communication sent in recently by the Winnipeg Trades Association regarding alleged partiality in selection of motor trucks by the direct. "We do not have to account for our decisions, and they have no right to question it," stated one of the board members, adding, "If the firms comprising the association doubt our action, we do not necessarily have to consider any tenders from them."

### SASKATCHEWAN

MOOSE JAW.—The Canadian Garage suffered considerable loss recently through fire.

REGINA.—A. Matheson, sales manager of D. Achland and Son, Ltd., Winnipeg was a visitor here recently.

MOOSE JAW.—Messrs. Edwards and King, implement dealers of Regina, have opened a branch at Moose Jaw.

INDIAN HEAD.—The McKenzie, Thresher Co., Limited, was recently incorporated with a capitalization of \$25,000.

REGINA.—H. A. Jones, of the Jones Tractor and Implement Co., Regina, visited the Bates Tractor Co., at Joliet, Ill., recently.

INDIAN HEAD.—The Union Garage and Machine Shop Company, Ltd., was incorporated recently. They have the Gray-Dort and Chalmers' agencies, and carry a full line of accessories.

WAPPELLA.—Kidd and Clements, hardware, farm machinery and automobile dealers, have sold out their hardware interests to the A. M. Naim Hardware Co. The firm will now specialize in implements, automobiles and accessories.

### ALBERTA

CALGARY.—The Red Star Vulcanizing Co. has been dissolved.

CALGARY.—Messrs. Hoare and Poach have opened an automobile trimming plant.

RED DEER.—F. R. Weaver is conducting an up-to-date tire and vulcanizing business here.

CALGARY.—F. L. Leif, of Norton and Leif, implement dealers, visited the factory of the Electric Wheel Co., Quincy, Ill., recently.

## Hindview AUTO MIRRORS



Style A



Style D — For Motor Trucks



C Bracket  
for Closed Bodies



Style A — Long



Style F  
for Front Fenders

The "Hindview" Auto Mirror prevents accidents by enabling the driver to keep an eye on the rear traffic without losing sight of the road ahead. Our Ball Joint allows immediate adjustment to any desired angle without the use of any tool.

Substantially made—nicely finished—has five-inch plain, or lens, plate glass mirror. The lens mirror increases the field of vision about 50 per cent. without distorting the view. Note large, firm clamp for attaching to windshield.

Write for our folder showing complete line  
Agents, Jobbers, Write for our Proposition



Superior Quality

Prompt Deliveries

### PRESSED METAL PARTS, LIGHT AND MEDIUM WEIGHT STAMPINGS

Our complete plant, superior equipment and efficient organization are at your service. You will insure satisfactory results by letting us make your stampings. Motor, axle, transmission and clutch stampings. Write to-day enclosing blue print for samples for estimates and our catalog.

### KALES STAMPING COMPANY

446 West Lafayette Blvd.

Detroit, Michigan

Canadian Representative: Donald F. Johnston, 146 Bleury St., Montreal, Que.; Yonge and Dundonald Sts., Toronto, Ont.; 612 Portage Ave., Winnipeg, Man.



**SHARPLES**  
**SUCTION-FEED**  
**SEPARATOR**  
 is the only  
separator that  
skims clean at  
any speed

## An Investment That Pays 50% Annual Interest

**T**HE Sharples Suction-feed is not only a *profitable* investment. It is *safe* and *certain* for dealer and user alike.

"Tests at Purdue University showed that fixed-feed separators, (*all others except Sharples are fixed-feed*) when turned under speed, lose 7.28 lbs. of butterfat per cow in a year.

"With ten cows, and butter at 65c per pound, you can lose \$47.32 a year with a separator that wastes but-

terfat when turned 'under speed.'

"The Sharples Suction-feed *skims clean at any speed*. It will save *that \$47 and more* in one year—a return of 50% on your investment."

The Sharples Dealer handles the most efficient, most widely-used cream separator made. When he offers *facts* and *figures* like the above, another fixed-feed separator makes way for the modern Sharples Suction-feed.

# Sharples

## SUCTION-FEED CREAM SEPARATOR

The Sharples Separator Company

Toronto, Ont.

2368 Dundas Street West

Branches:

Montreal, Que.

314 Notre Dame West

Regina, Sask.

1845 Rose Street



**Skims  
clean  
at any  
speed**

What "Sterling" means to silverware "Sharples" means to dairy machines—and more—for "Sharples" not only pledges quality-materials. It is insurance of *continuous service to users* by the Sharples dealer.

—P. M. SHARPLES

"There are no substitutes for dairy foods."



# CHAPMAN ROLLER BEARINGS

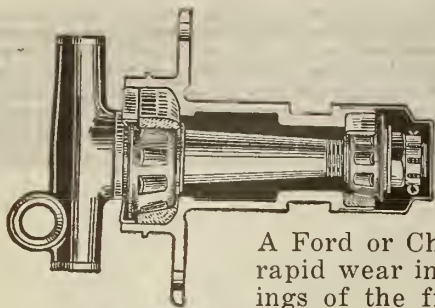

**EVERY FORD AND CHEVROLET A PROSPECT**

A Ford or Chevrolet car is subject to rapid wear in the cup and cone bearings of the front wheel, because the hub is too small to take a cone bearing with a sufficient factor of safety.

Chapman Roller Bearings overcome this difficulty and are easily installed. Every Ford and Chevrolet is a prospect.

## Chapman Differential Thrust Bearing

Readily substituted for the plain, flat washer in the differential of Ford or Chevrolet. The flat washer wears out due to heavy end thrust.

When worn there is lost motion in the gears and incorrect contact of teeth, causing extreme wear, and noise.

The Chapman Differential Thrust Bearing exactly replaces the washer with no other changes required.

It takes the pressure on steel balls, reducing friction to a minimum and holds the gears in perfect mesh.

Get our dealer proposition by a post card today.

### Chapman Advertising and Increasing Sales

Are daily making this a better opportunity for you. We want dealers in every locality. Chapman advertising is reaching every car-owner and garage man.

Advertising, and Chapman co-operation with dealers, has greatly increased sales until it offers you a very profitable opportunity.



**THE CHAPMAN DOUBLE BALL BEARING CO.**

OF CANADA LIMITED

347 Sorauren Ave., Toronto, Ont.

# BIRDSELL CLOVER HULLERS

**HULL AND CLEAN**

**Common Red, Big English or Mammoth, Alsike, Crimson and Sweet Clover Seed**

**BUILT IN THREE SIZES FOR CANADA**

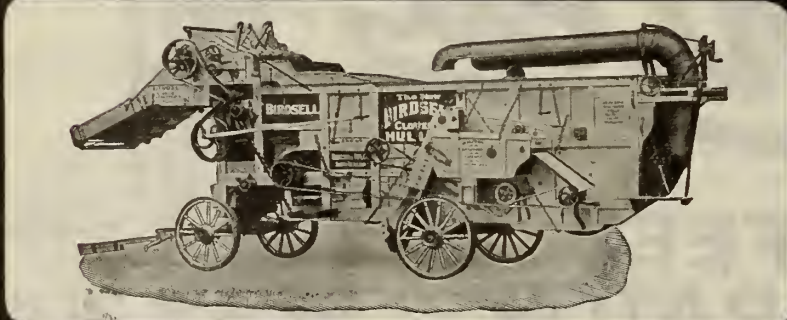

## BIRDSELL "QUALITY" IS SUPREME

**T**HERE are Birdsell Hullers in use today that have been in the field every season for 40 years. That means **SERVICE**—it means **ECONOMY**—it means **SATISFACTION**. It is easy to discern why 35% of all Hullers in use throughout the World are of Birdsell make, when you know what **SERVICE** they give.

We invite you to write or call on us. Our traveling representative will call on you at your request.

**BIRDSELL MFG. CO., TORONTO**

FOOT OF GEORGE STREET

# NEWS — OF THE TRADE FOR THE TRADE

## ONTARIO

**BARRIE.**—F. Van Patter has sold out to Messrs. Buchanan and Son.

**TORONTO.**—The Dayton Airless Tire Co. of Canada, Ltd., has been voluntarily wound up.

**KITCHENER.**—An automobile show will be held here from April 19 to 24. G. O. Phillip will be manager.

**HAMILTON.**—The Provincial Secretary has accepted the surrender of the charter of the McGregor-Banwell Fence Co.

**TORONTO.**—Cutten and Foster, Ltd., Toronto, have been appointed distributors for the new Burd quick-seating piston ring.

**TORONTO.**—The Maple Leaf Sales Agency, distributors of Maple Leaf trucks, has added to its line the Standard motor truck.

**KINGSTON.**—Suddaby Bros., Wellington Street, are installing a gigantic hydraulic press for applying motor truck solid tires.

**TORONTO.**—The Toronto Motor Car Co., has rented a portion of the Horticultural Building, Exhibition grounds, for storage purposes.

**BELLEVILLE.**—At a recent meeting of the Police Commissioners it was decided to purchase a Ford car for the use of the Police Department.

**TORONTO.**—The United Auto Sales Ltd., 545 Yonge Street, distributors of Chalmers and Maxwell cars, have been appointed distributors for the Federal trucks.

**RENFREW.**—L. D. Smith, general traveler for the Renfrew Machinery Co.'s truck scale division, recently went to the United States to call on the Renfrew jobbers.

**TORONTO.**—The Western Motors Co., Ltd., has been incorporated with a capital stock of \$40,000. The new company will manufacture tractors, implements and automobiles.

**TORONTO.**—J. J. Burns of the Auto Bus Transit Company announced recently that an hourly service between Sunnyside and Oakville would be inaugurated about April 15.

**OTTAWA.**—The Canadian Trade Commission has been informed of the decision of the Greek Government to permit the importation, duty free, of farm machinery and implements.

**TORONTO.**—The Tube Company of Canada, Limited, has been incorporated with a capital of \$100,000, for the manufacture of metal tubing, sheet metal, hardware and stamped and drawn products.

**TORONTO.**—The incorporation is announced of the West Furnace Carburetor Company of Canada, Ltd., at a capitalization of \$100,000. The new concern will manufacture and sell furnace carburetors and parts.

**OTTAWA.**—A new company, the Anglo-American Motors, Limited, with a capital of \$10,000,000 has been formed. It is understood those identified with the venture are Montreal, New York, Detroit and Cleveland interests.

**HAMILTON.**—A deputation from the Western Ontario Highway Association and from municipalities between Niagara Falls and Windsor will wait on the Ontario Government early in March to ask that Provincial highways be made of a permanent nature, surfaced with asphalt or brick.

**NEW LISKEARD.**—The International Harvester Company of Canada held a tractor school in the Judging Pavilion of the Government building on March 2, 3 and 4. Lessons on the care and operation of tractors, engines and threshers were given.

**TORONTO.**—T. N. Phelan, solicitor of the Ontario Motor League, has gone to England, where he will confer with officials of the Royal Automobile Club and the Motor Union on several matters of interest to Ontario motorists.

**NIAGARA FALLS.**—Chief Welch in his report to the Police Commission recently, said that parking of automobiles in the streets had become a nuisance and suggested a no-parking by-law claiming that they obstruct business.

**HAMILTON.**—It is reported that the promoters of the Runnard grain shocker, which has been patented by G. L. Park of Hamilton, have received an offer of \$500,000 from an American concern for the exclusive manufacturing rights.

**WINDSOR.**—The Champion Spark Plug Company of Canada Ltd., opened a factory here recently. The Mayor of Windsor started the first wheel turning. The factory is of reinforced concrete, has a frontage of 75 feet and a depth of 100 feet and is expected to employ about 150 hands.

**AMHERSTBURG.**—A new company has been formed, with factory located here, to build a Canadian designed five-passenger touring car. Dr. William F. Park, Mayor of Amherstburg is President, and W. R. Stantell, Vice-President.

**HAMILTON.**—R. J. Magor, formerly of Montreal, has been elected president of the recently incorporated National Steel Car Corporation Limited. Mr. Magor has been president of the Magor Car Company of New York, and returns to Canada in the dual position of president and general manager of the new company.

**HAMILTON.**—The Connaught Motor Sales Co., 79-85 Main Street East, is planning extensive alterations to its present premises. When the remodeling has been completed the company will possess one of the finest and largest automobile salesrooms in the city. The firm has the agency for Studebaker cars and Federal and Commerce trucks.

**TORONTO.**—Announcement is made of the incorporation of the General Top Company of Canada, Limited, at a capitalization of \$300,000. The new company has taken over the plant of the Curtiss Airplanes, Ltd., at 163 Dufferin Street, Toronto, and will manufacture Artercraft tops for automobiles. The officials are: President, R. C. Kilgour; Vice-President and General Manager, L. W. Lee; Secretary and Treasurer, W. L. Cowan; Sales Manager, H. A. Kent.

## MANITOBA

**WINNIPEG.**—The Western Canada Motor Car Co., recently finished second in the Packard truck sales competition, having sold 13 trucks in the period set.

**WINNIPEG.**—Announcement is made of the incorporation of the American Grain Separator Co. in Canada, with headquarters here. Mr. H. Lewis has been named as agent.

**BRANDON.**—R. D. Roach, who for the last fifteen years was associated with the Ford Motor Company, Winnipeg, has joined the forces of the Western Motors, Limited.

**WINNIPEG.**—The Fortuna Cream Separator Co., Ltd., was incorporated recently with a capital stock of \$20,000. The company will handle a Swedish cream separator.

**WINNIPEG.**—A new company, The Service Motors Ltd., has been formed here with headquarters in the old Mariaggi Hotel, on McDermott Street. The new concern has the agencies of the Cleveland and Chandler cars and the Service motor trucks.



THE COMMERCIAL CREDIT COMPANY OF CANADA LIMITED

IS

A CANADIAN COMPANY offering service of interest to and in the interest of Canadians.

Time payments made possible and profitable for Manufacturer, Dealer and Customer. Of particular interest to Automobile and Musical Instrument Trades.

LET US KNOW YOUR REQUIREMENTS

THE COMMERCIAL CREDIT COMPANY OF CANADA LIMITED

Bank of Hamilton Building, Toronto, Ontario  
McArthur Building, Winnipeg, Man.

WE GIVE

**“Quality and Service”**

IN

TRACTOR and TRUCK  
STEEL CASTINGS

**JOLIETTE STEEL CO., LIMITED**

903 Read Building, Montreal  
JOLIETTE, P.Q.

**Mr. Dealer!**

**IF**

Price  
Quality of Material  
Workmanship  
Close Skimming  
and  
Easy Turning

are considered by your customers in buying a Cream Separator, then we claim that the

**Sanitary King**

is the best buy in Canada to-day. Write for prices and terms.

--

**King Separator Works of Canada**

Limited  
Bridgeburg or Whitby, Ont.



SAYS THE MASTER MECHANIC: The Greb Automatic Grip Puller is a One-Man Puller—Quick-acting, strong and simple in the extreme. May be locked in any desired position. A combination of two or three arms. Heavy Duty Size capacity 1" to 1 1/2". Junior Size capacity 1/2" to 7/8". Two sets of jaws furnished with each size.

TEN DAYS' TRIAL.—If your dealer or jobber does not have them we will send you one. Try it ten days. If not satisfactory, return to us and we will refund your money. We also make the GREB RIM TOOL.

THE GREB COMPANY, 319 State St., BOSTON

Broughton's  
Blowout  
Boots Bind  
Bad Breaks  
and Bruises  
Best



Keep them on hand to repair any automobile tire weakness.

At your dealers or

The Geo. H. Broughton Company  
122 Wellington St. West, Toronto, Ont.

Out of the Frying Pan

“Has your present wife a more even temper than your first had?”  
“More even? No, even more.”—Boston Transcript.

Laughing Matter

The sessions in a certain town were in full swing. On the third day a dreadful calamity occurred—the court crier was absent.  
“Well, we must find a substitute,” remarked the Judge.  
Just as they were in the middle of an exciting case, a breathless messenger boy came in and handed a letter to the Judge. The latter read it, and then announced to the court:—  
“I have a message from our court crier. He says: ‘Wife’s mother died last night. Will not be able to cry today.’”—London Tit-Bits.

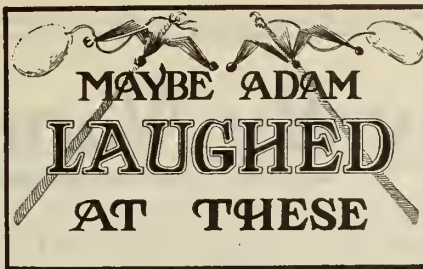

Over the Hill

“This car of yours will land me in the poorhouse.”  
“Well, it’s a good thing I picked out a hill-climber, hubby.”—St. Louis Republican.

The Easier Way

An enterprising dealer in electric wares hangs out the sign: “Don’t kill your wife with hard work. Let our washing-machine do the dirty work.”—The American Legion Weekly.

A Popular Make

“The officer says you used bad language.”  
“When he stopped me I was in a tantrum.”  
“Never mind the make of the car.”—Judge.

What Interests Papa

“That young man stayed very late again, Edith.”  
“Yes, Papa; I was showing him my picture postcards.”  
“Well, the next time he wants to stay late, you show him some of my electric light bills.”—Boston Transcript.

A Golf Handicap

“I wouldna say McTavish canna learn the game,” remarked Sandy, as they trudged home from the links, “but it will be deeficult for him.”  
“Aye,” agreed Donald. “At times he will be like to bust, what wi’ being so religious and tongue-tied.”—Everybody’s.

Camouflage

“How was the banquet?”  
“Fine. Father gave the toast to the ladies.”  
“He did, eh? That’s just like him letting on to a lot of other women that he’s so kind and considerate when he wouldn’t make toast for me in the morning if my head was splitting open.”—Detroit Free Press.

The Wrong Man

“Buy your automobile of us,” said the enterprising dealer, “and we will make you a present of a handsome motor clock.”  
“You are not the man I’m looking for,” replied the other. “I am trying to find a seller of motor clocks who will throw in an automobile.”—Boston Transcript.

Literally Spoken

Spank! Spank! Spank! Tommy was undergoing material chastisement at the hands of his loving mother for eating the jam.  
“Tommy,” she said, when she had paused for breath, “do you know this hurts me more than it does you?”  
And when Tommy was alone with his brother he produced a square board he had concealed, and murmured:  
“I thought that bit of wood wouldn’t do her hand any good.”—Tit-Bits, London.

Magnanimous

A five-year-old boy, on being put to bed a few nights ago, threw his arms around his mother’s neck and said:  
“Please don’t leave me, mamma, I’m afraid to be left alone in all this dark.”  
“But you mustn’t be afraid, Freddie,” was the mother’s reply. “You’re not alone. God’s with you.”  
The little fellow was silent, and, thinking he had lost all fear, his mother quietly joined her husband downstairs. A few minutes later Freddie’s voice was heard from the top of the stairs:  
“Mamma, mamma!” he cried. “Come up, you stay with God in the dark and I’ll stay with papa in the parlor.”

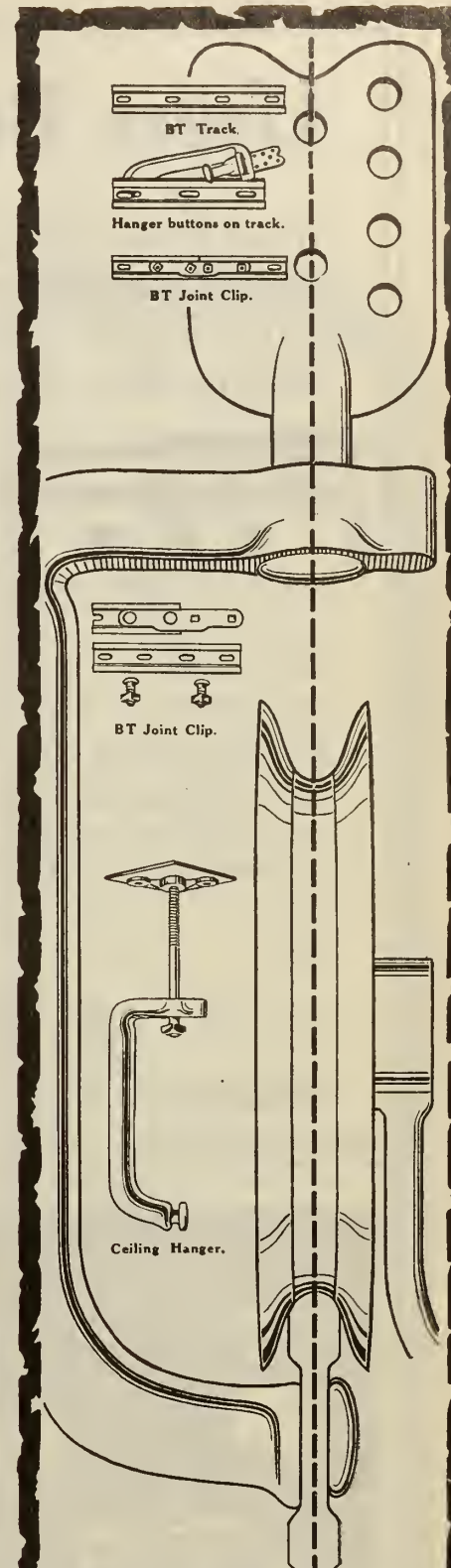

Hung on centre  
will not tip.

**Everybody Wants BT Manure Carrier Track**

Because:—  
It is made specially for Manure Carrier Work.  
It is centre hung and will not tip over.  
It offers no surface on which snow and dirt can collect.  
The rounded surface causes no friction.  
It is easily erected, and because the hangers just “button-on”—no bolts or nuts to bother with. It can be bent to any curve without heat.

**Beatty Bros., Limited**

Fergus, Ont. Montreal  
London, Ont. St. John, N.B.  
Winnipeg Edmonton  
Vancouver London, England

Manure  Carriers



## Users Buy By Name

those things that give them greatest satisfaction. Which is true of wrenches. Carry the best wrenches that users have found, through experience, to be thoroughly dependable—

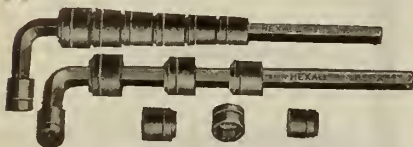

"HEXALL" Socket Wrench  
No. 5—8 pieces

## "HEXALL"

Trade Mark Reg. U.S. Pat. Off.

## Socket Wrenches

and you have a fast-moving line, generous in profit, a promoter of lasting friendship and goodwill. For, there are no better wrenches made than "HEXALL"—*a set for every need.*

Every "HEXALL" has that bulldog strength which is the result of long experience in fashioning steel for this purpose. Thus, handles are drop-forged; sockets made from the bar on automatic machines, broached and case-hardened. And, not satisfied with the production of mechanically-perfect tools, the makers guarantee every "HEXALL"—

*"Break any Sedgley Wrench and we  
repair it—no charge"*

**R. F. SEDGLEY, Inc.** Est. 1897

*Also Makers of "BABY" Hammerless Revolvers*

2311-13-15 NORTH 16th ST., PHILADELPHIA, PA.

LAMONTAGNE, LIMITED, MONTREAL, CANADA

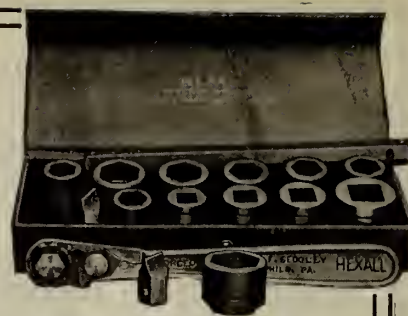

"HEXALL" Ratchet Socket  
Wrench No. 1—16 pieces

"HEXALL" Ratchet Socket  
Wrench No. 2—11 pieces

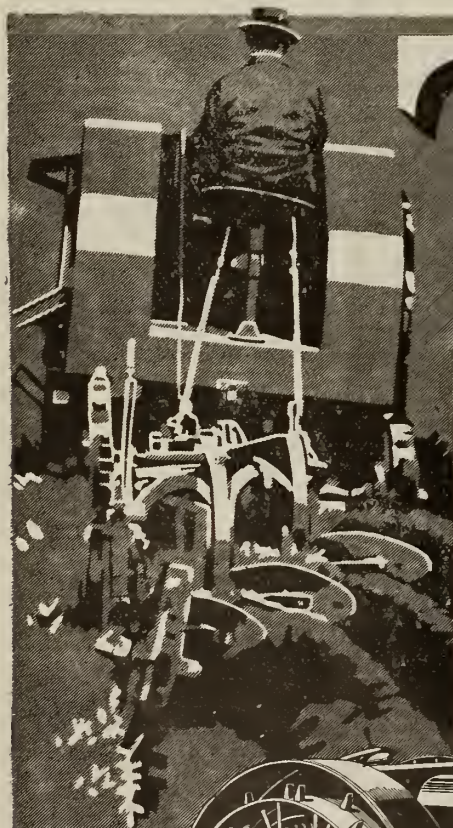

# TURNER Simplicity

## The Tractor You Sell

is only as attractive as the tractor is tried and proven, practicable, and economical in operation. Continued sales, easy service demands, and contract renewals throughout the country prove that Turner success is hinged upon built-in principles of proven merit, of economy and service.

Turner Simplicity has met the demand for a tractor that can be relied upon for constant performance on a wide range of work. On drawbar and pulley jobs the efficient delivery of power to wheels and belt has won Turner lasting reputation. Its reserve power to meet overload conditions, its low fuel costs, easy handling and thorough dust protection, contribute to the increasing sales records that have grown apace with production facilities.

It is significant that the Turner is handled by leading distributors the country over. For immediate action on territory proposition—address

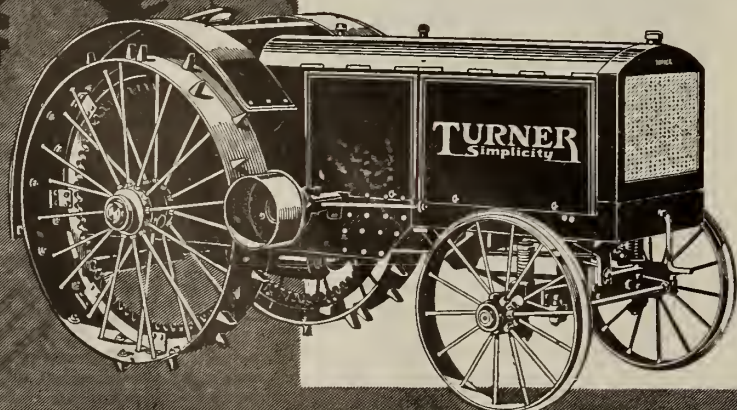

**The Turner Manufacturing Co.**

441 Lake Street, PORT WASHINGTON, WS.



# Contract Now For Viking Separators

Get Protected Territory



There is going to be more money made by dealers selling VIKING cream separators in 1920 than will be made selling any other line.

Some excellent contracts are open for dealers who want to make money out of the separator business—guaranteed territorial rights—service and selling assistance.

Read our statements of profits for dealers. Our guarantee to stand behind the goods and our offer of assistance for you in helping to get the business started in your section.

If it is dollars and cents that you are interested in, then we know you will write us.

Fullest of particulars given the dealers with absolutely no obligation on their part.

Write To-Day  
Dept. B.J.

**SWEDISH SEPARATOR COMPANY**

Montreal: 422 Power Bldg.  
Winnipeg: 714 Confederation Life Bldg.

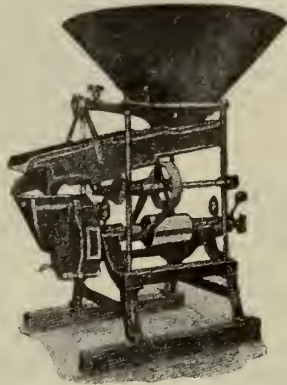

We Have Manufactured

# GRINDERS

and nothing but Grinders for over 35 years

Wherever you find a "Vessot" Grinder you will find a contented user. The "Vessot" always satisfies. Vessot Grinders have obtained medals and highest awards wherever exhibited—Chicago, Paris, etc.

We make nine different sizes of grinders 6½", 8", 9" 9¼", 10½", 11" B Farm Type and 11", 13" and 15" Mill Type, or in other words, we build a machine to meet all requirements.

The Agency for "Vessot" Grinders will net you good commissions and satisfied customers.

May we mail you our agency proposition?

**S. VESSOT & CO.** Sole Manufacturers **Joliette, Que.**

Sold exclusively in Canada by International Harvester Co. of Canada, Limited  
Branches: Calgary, Edmonton, Lethbridge, North Battleford, Regina, Saskatoon, Yorkton, Brandon, Winnipeg, London, Hamilton, Ottawa, Montreal, Quebec, St. John  
Write to the nearest International Harvester Branch for Free Booklet giving complete information

# THE IRON JINX

Continued from page 17

tains which flapped frantically. A conversation carried on in shouts becomes a strain on the vocal cords when prolonged for any length of time.

Finally Flanders essayed to renew verbal acrobatics.

"Live far from here?" he roared, punctuating the query with a spasm of coughing.

"About a mile and a half, I should say."

"Must have been your place I sighted just as the storm broke."

"Undoubtedly, as it's the nearest human habitation."

"Are we on the road yet?" queried Flanders who was beginning to feel the need of a pilot familiar with these wild "shores."

"I believe so; but be very careful—there's a deep coulee that we will have to cross some distance ahead."

"Aye, aye, captain!"

Another pause. Flanders was beginning to grow concerned regarding the road. It was almost entirely obliterated and there were no telephone poles nor fence posts along the road to serve as guides. He began to entertain misgivings which were voiced by the girl as she shouted:

"It's getting dark. Haven't you a headlight so that we can see in a measure, at least, where we're going?" There was a note of anxiety in her voice that found a ready echo in Flanders' heart.

"No—haven't got a headlight," growled Flanders. "They hung everything but the kitchen stove an' a headlight on this old wreck when they rebuilt it. It's a made-over tractor, you know. There's an electric flashlight in my tool kit on the floor if you can find it. It might help some—see what we're doing in the cab, anyway."

After some fumbling among a varied assortment of wrenches, oil cans, hammers, screw drivers, bolts, etc., the electric torch was unearthed by a triumphant young lady. She thereupon proceeded to focus it upon the various objects in the cab and apparently for the first time discovered the hot-air manifold.

"What's that for?" she asked, indicating the discovery.

"Hot-air drum for the kerosene fuel intake," replied Flanders. "Makes a nice stove. Better lean up against it—it'll keep you nice and warm."

"This is grand," enthused the assistant engineer as she followed Flanders' advice. "All the comforts of home."

The device in question was a drum somewhat resembling a long section of stove pipe and occupied a prominent place in the tractor cab. The exhaust pipe of the tractor passed through this drum, and on through the roof, heating the air for the fuel mixture by means of the exhaust gases from the cylinders.

Conversation died. Flanders was now too much occupied with the task before him to talk. The road had entirely disappeared, being obscured by the swirling snow and darkness. Flanders was steering the tractor by "feel" and his sense of direction. He rolled up one of the front curtains and strained to see ahead into the darkness, but the cold wind and powdery snow filled his eyes, causing a watery blur. The road was becoming uncommonly rough. The tractor jolted and bumped along as if riding over the unbroken prairie. Flanders was considering the advisability of stopping for a moment to investigate the situation, but of a sudden this consideration resolved itself into instantaneous action of a different kind. The front wheels of the tractor were dropping abruptly away!

Flanders was thrown heavily against the steering wheel as the Jinx lurched forward at a perilous angle and for a brief fraction of a second he experienced a sickening, "gone" feeling. But only for an instant. Trained to emergencies and quick decisions he met the present situation squarely.

To be continued

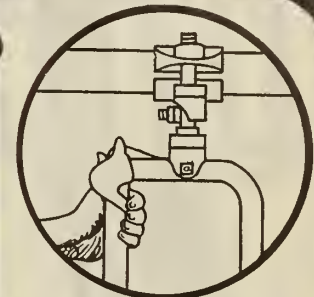

Lock opened with one hand

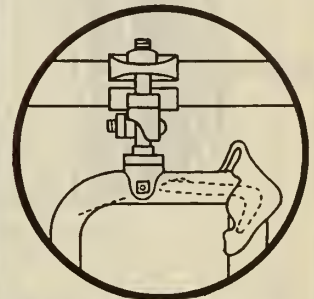

The Lock is Simple, Strong and Safe

## BT Stanchion Is Best

It ties the cow with absolute security. Yet she can stand up, lie down, turn her head, reach her feed or card herself in perfect comfort.

There are no V shaped parts to pinch her neck. Cows can be tied and untied in a moment.

Only one hand is needed to open the stanchion.

The top and bottom connections are strong and substantial and will stand the heaviest strain.

The Stanchion itself is made of extra heavy U-Bar Steel.

Your customers will get years of hard service out of BT Stanchions.

### Beatty Bros., Limited

Winnipeg, Man. Fergus, Ontario  
Edmonton, Alta. London, Ontario  
Vancouver, B. C. Montreal, Que.  
St. John, N. B.  
London, England, 16 Holborn Viaduct

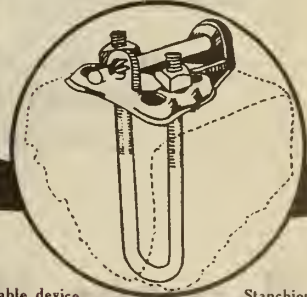

Adjustable device to hold

Stanchion in the the Cement

Steel  Stalls



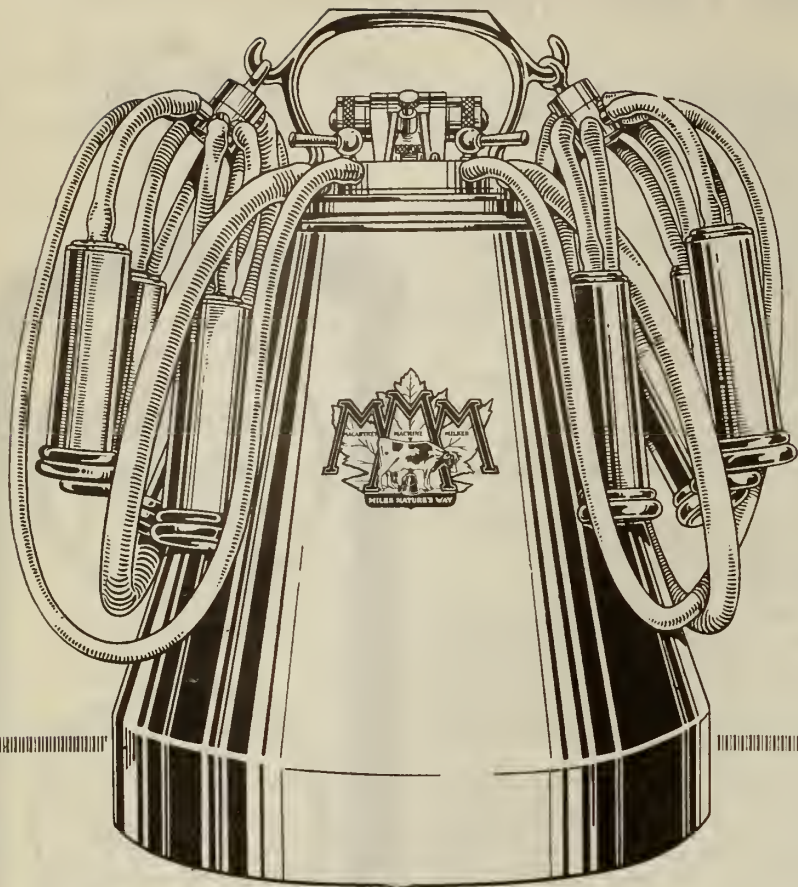

THE COW'S ADOPTED CHILD

## \$6,000 For Five Months' Work

Five months work as agent for the **Macartney Machine Milker** netted one aggressive dealer the handsome figure quoted above. Six thousand dollars for five months' work—and in addition to this the absolute certainty that every milker sold means a customer satisfied in every particular.

You feel like envying that man, do you not? But—why envy him? Be that man. What he has done you can accomplish. For the case in point is not exceptional. It is merely quoted to illustrate what a big thing the **Macartney Machine Milker Agency** is for a live man in any good dairy district.

We want a representative in every such territory. Will you represent us in yours? The time was never more opportune. Shortage of farm labor, plus the sky-high prices of dairy products make the **Macartney Machine Milker** a sound investment for every farmer.

*And our dealer proposition is attractive. Ask us to mail you detailed particulars.*

*The*  
**Macartney Milking Machine Co.**  
 Limited  
 OTTAWA

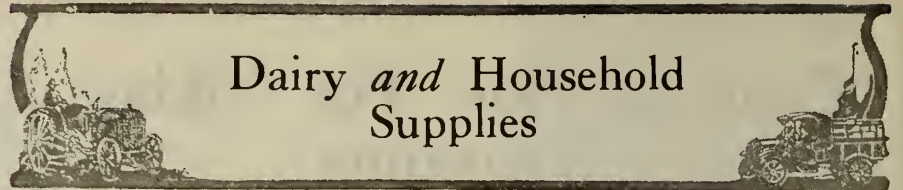

### HI-SPEED WATER SYSTEM

A WATER system of much interest to dealers and containing many new features has just been put on the market by the Goulds Mfg. Co., Seneca Falls, N.Y. It has been designed especially for use in connection with water supply systems for farm, homes and buildings, dairies, creameries and small town homes.

It is noiseless in operation, say the makers, and has self-oiling and priming features.

It consists of a figure 1695, 1¼ in. x 1½ inches, three gallons per minute high-speed pump, fitted with air cock, connected by means of a ¾ inch round belt to a ¼ h.p. electric motor, alternating or direct current as required.

The pump and motor are mounted on a wood base 10 inches wide, 30 inches long, and 1½ inches thick. The tension on the belt is provided by a new type of floating idler fastened dir-



The Goulds High Speed Water System

ectly on the wood base. This outfit is mounted on a galvanized welded steel tank, both heads being bumped out.

The tank has an approximate capacity of 30 gallons and is supported on cast iron feet. The outfit is equipped with automatic pressure regulator, pressure gauge relief valve piping and fittings.

All gears have been eliminated, thereby making the pump noiseless in operation. It operates at a speed of 500 revolutions per minute.

There is a specially constructed priming chamber through which the pump is primed. When once primed, the makers say, the pump will pick up the water for an indefinite period without re-priming—a necessary point in automatic operation.

### ADVANTAGE OF A SEPARATOR

IN a recent issue of the *Rural New Yorker*, there appears an article on the advantages of a cream separator which will furnish the dealer with some good talking-points in selling his machines. We reproduce it here in part:

In these times of strikes and other troubles in the milk market the dairy farmer with a cream separator has quite an advantage over those who are "bare handed" when they find themselves without any market outlet for their milk, as they did during the past winter. The past experience goes to show that there is no telling when these troubles will come. The farmer with a cream separator and a few other facilities for taking care of the milk is quite independent as far as the shipping stations, condenseries and middlemen are concerned.

No farmer, with even only five or six cows, that works up the milk at home should think of doing without a separator. It is a big job making butter without one in warm weather, keeping all the milk cool, and in winter, keeping it from freezing, then hand skimming, washing pans, crocks, etc. It takes only a few minutes' time to separate the milk, and then all you have to care for is a few gallons of cream.

For growing pigs there is nothing like this warm separated milk fed while the animal heat is in it, and with a little scalded bran or shorts in it the finest of calves can be raised.

Many farmers who have been patronizing the shipping stations or creameries right along have found that they made a good investment when they purchased a separator. It makes a little more work at home, yet not so much either, when things are handily arranged, as some think it would.

Some farmers are skimming the milk at home and delivering the cream. There are some advantages in this way. The cream can be delivered more cheaply than the whole milk, and aside from this the skim milk is left on the farm, sweet and in good condition, to feed, and if there is no tuberculosis in the dairy and you continue to feed your own skim milk on the farm you will be pretty sure of growing up a dairy that will be free from this disease, something that you can not be sure of when feeding the calves mixed skim milk that comes from the creamery.

The question has been asked, does a cream separator remove all the impurities from the cream? I would say, it takes out the insoluble dirt and a proportionate part of the bacteria, but does not remove the products produced by the bacteria that have been working in the milk.

### SEPARATOR SERVICE

W. E. TRAVER, Welland, Ontario, discussing cream separator service with M. T. I., has the following to say:

"What should the dairy farmer look for most when considering the purchase of a new cream separator? The answer to my mind is "SERVICE." Not service in the sense that has been commonly practised, but real honest-to-goodness, every-day service—use of his machine night and morning, 365 days in the year. Most cream separators offered to Canadian farmers are built of good materials, nearly all use good bearings, shafting and gears, and most machines skim fairly clean. Why is it then that throughout this country there are hundreds of machines discarded, especially when they show upon examination that the gearing, shafting and main body are still in condition to give seven or eight years' more work? Is not the answer this: Separator-bowls get out of balance and commence vibrating after about five or six years use. This vibration causes uneven wear on bearings, the bowl begins to shake badly. The local implement dealer instead of advising his customer to get the bowl re-balanced and a bearing or two renewed, advises the customer to trade his separator for a new one. Many arguments are put up by the dealer that are accepted by the farmer simply because he lacks the understanding of the true condition of his machine and does not know how easily it could be repaired.

Isn't it about time for both the separator dealer and manufacturer to awake to the fact in justice to their customer that they should deliver something besides a bunch of iron, steel and tinware when they sell the dairy farmer a cream separator? Should they not realize that the successful merchandising of any article should include a service to the customer? In other words, some real satisfaction.

There is a wonderful field in Canada for the marketing of cream separators of some company that will install a real service department in their business; keep the customer advised in the care of his machine, educate him in their operation and care through bulletins and service men, and insist that dealers render a service when the customer is in difficulty.



# DE LAVAL

## Efficiency

The DE LAVAL Cream Separator is the most efficient means of separating cream from milk. It skims to a trace, not only under ideal conditions, but under ordinary farm conditions.

It is efficient because forty years of separator building experience has brought out the best construction in every detail. That's why the DE LAVAL skims so close, turns so easy and lasts so long.



The DE LAVAL Agency Contract is an efficient means of getting most of the separator business in a territory, at the same time building prestige for other lines.

There is no better time than right now to send in an application for a De Laval contract. There is more profitable cream separator business with the De Laval than with any other separator.

### The De Laval Company, Ltd.

*Largest Manufacturers of  
Dairy Supplies in Canada*

Montreal Peterboro Winnipeg Vancouver

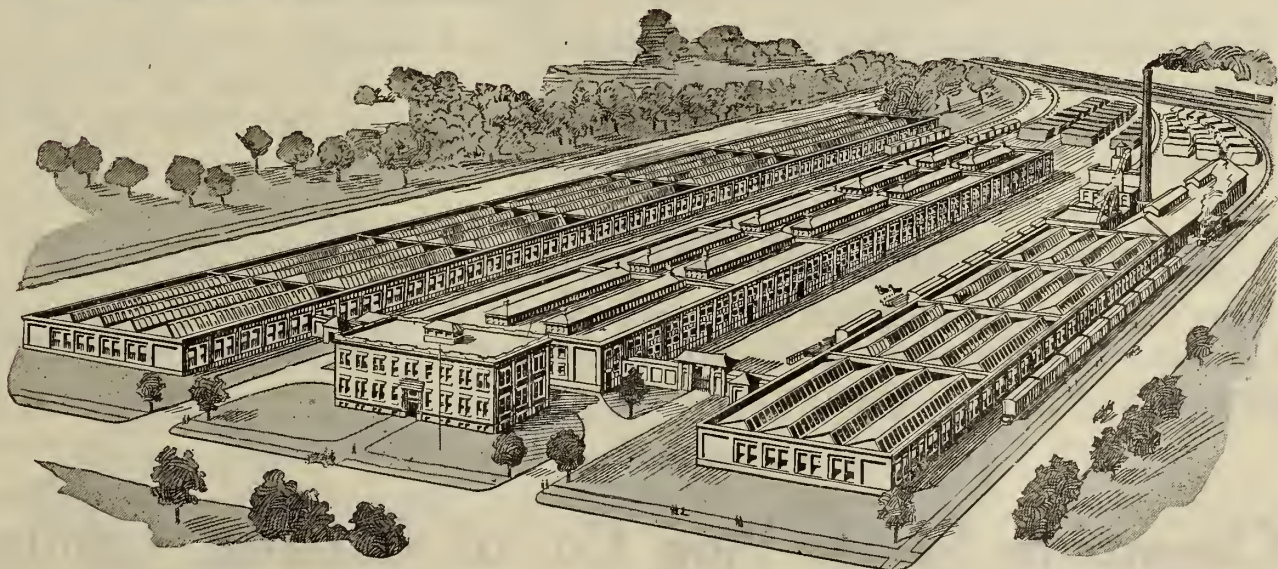



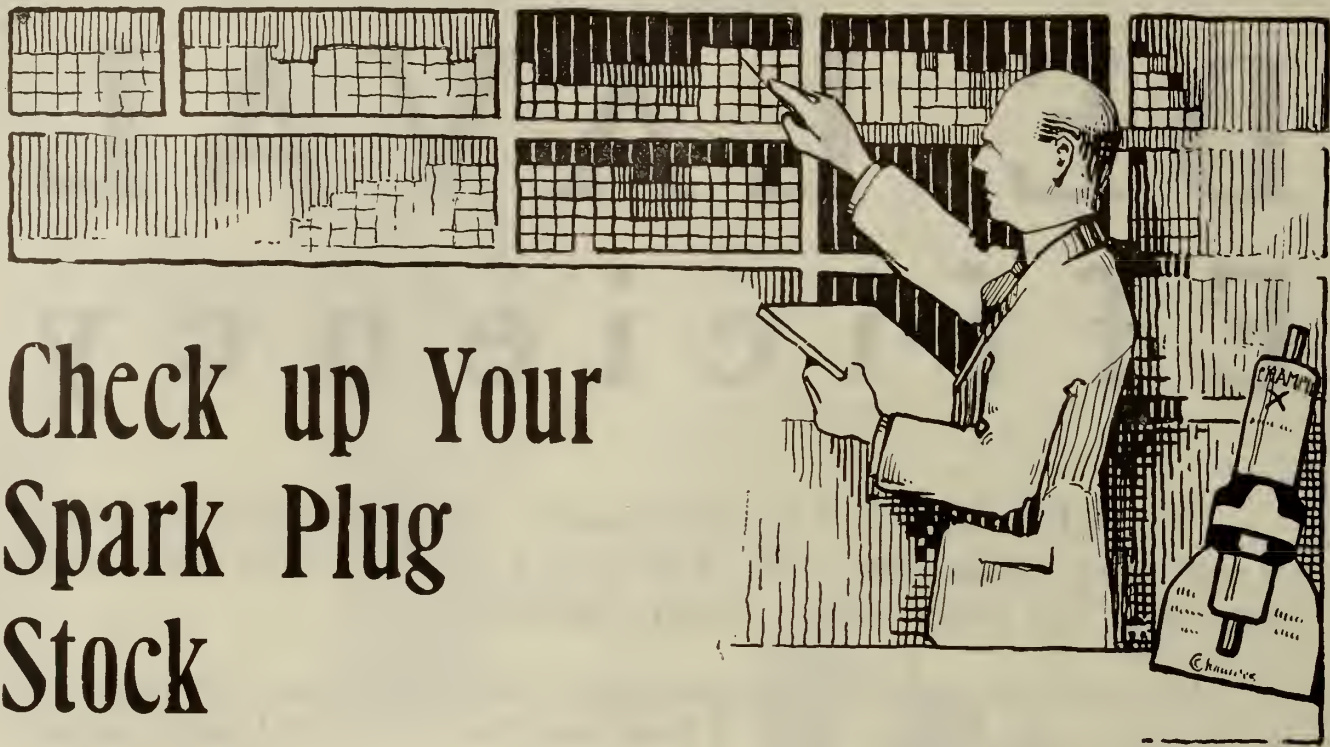

# Check up Your Spark Plug Stock

Now is the time to be prepared to meet every demand for spark plugs. Motor car registrations have reached a new high level—more motor trucks are being employed and more tractors and gas engines requiring spark plugs are in use than ever before.

 **Champion**

## Dependable Spark Plugs

are factory equipment on four out of every five gasoline motors in use. This is significant of the dependability of Champions. They are selected by those experts who develop automobile engines to give the highest efficiency at the lowest cost.

Champions with 3450 "Plus Service" Insulators and patented compression-proof gasket construction are the spark plugs your customers will insist on having for replacements. Our advertising is educating them to know their efficiency and dependability. Champions are guaranteed to give

*"Absolute satisfaction to the user, full repair or replacement will be made."*

There's a Champion plug for every type and make of motor. Be sure you have the full line. It will not only build your spark plug business, but will increase your sales of other lines as well.

*Check up and order from your Jobber now.*

**Champion Spark Plug Co. of Canada, Limited**  
WINDSOR ONTARIO



# A Line of Quick and Easy Sellers

Hold 'Em in the Road

\$5.00

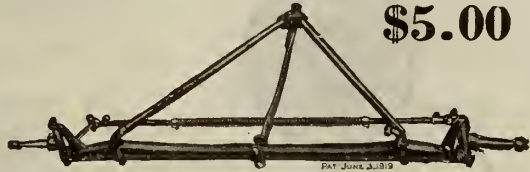

"Hold 'Em in the Road" for Ford Cars

Here it is, the Radius Rod Brace, Anti-Rattler Axle Support and Safety Device all in one.

There is no Ford car accessory made that possesses such a strong combination of strength and safety.

No. 5 bar fits old model Fords.

No. 5½ bar fits 1920 model.

## "Casco" Oil Drain Cock

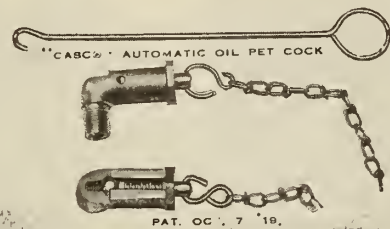

Pat. Oct. 7, 1919

The "Casco" Oil Drain Cock for Engine Crank Case is Automatic in action. No cock wrench is required.

No Ford owner should be without one, as it enables him to easily keep close tab on the oil level and prevent unnecessary wear of bearings.

Complete, per pair, \$1.50

## "Casco" Coil Box Protector

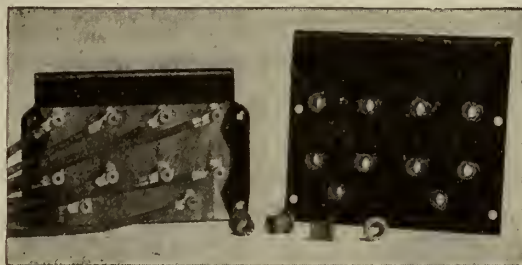

*The Only Protector for FORD CARS  
Against Rain and Wet Weather*

Ford cars frequently stall in wet weather. The water works in between the hood—into the coil box, causing short circuit.

This inconvenience is prevented if you use the "Casco" Box Protector. It covers the Ignition and Coil Box.

Dryness is guaranteed.

Without Rubber ..... \$1.00  
Rubber Insulated ..... 1.50

## Necessities like these are in big demand by Ford Owners

*Their advantages can be seen at a glance*

Dealers say "Casco" products are an excellent line to handle because of the demand—the profit—and the universal satisfaction. We would suggest that you place your order now to insure delivery before Spring opens up a big demand. If you hesitate you will lose some good sales.

Any of our Canadian representatives, as listed below, are in position to supply you promptly.

## "Casco" Fan Belt Guide

Put on in a Minute

50c.



Clamps here to Crank Case Flange

Clamps here to Crank Case Flange

## Casco Manufacturing Co.

THOMASVILLE, GA., U.S.A.

Canadian Registration Applied for

A. H. Frazier, 1150 Homer St., Vancouver, B.C.

Manufacturers' Agent

CANADIAN JOBBERS

Merrick-Anderson Co., Limited, Winnipeg  
John Millen & Son, Limited, Montreal, Toronto



### RUNNING BOARD MAT

**STANDLEY SKID CHAIN CO.**, Boone, Iowa, U.S.A., are putting on the Canadian market a Running Board Safety Tread, which they claim is a great boon to auto owners, in so much that it prevents slipping when stepping on the running board and also provides the particular car owners with a unique device for scraping mud and snow from the shoes.

The manufacturers state that these running board mats are made so as to attach to the running board in such a way that when they become filled with mud, etc., by lifting up on one side, the surface underneath may be swept clean in very short order, one side only being attached in such a way that the pivots form hinges, which are out of the way. They also claim that this device greatly adds to the appearance of the car.

This new Running Board Safety Tread is said to weigh 2½ pounds and is 12 inches in length over all, and is attached with clamps equipped with thumb screws. So far the makers have been producing this in Black Baked Japan Finish.

### TWO PART VULCANIZER

**THE Pechstein Iron Works, Keokuk, Iowa, U.S.A.**, have put on the market a two part inside cord patch vulcanizer for pneumatic truck tires. The P. I. W. vulcanizer was designed in halves instead of all in one round section, the makers say, because the stiff side walls of truck casings make it almost impossible to spread the beads far enough apart to insert the vulcanizer. One half is put into the tire, then the other half is inserted and slid along until both halves fit together over the patch to be vulcanized. The tread is then filled with wet soap stone, the tire wrapped, an outside vulcanizer placed over the patch and steam turned on just the same as on any other vulcanizer.

It is made of smooth castings, the two faces fitting together are machined and when placed side by side, the two halves conform to the inside of the size tire for which they were made. Each half has a steam connection and a pet cock outlet. A lug, cast on each end of the castings, has a hole into which a hook can be inserted and the two halves separated and taken out of the tire easily. They are made in five sizes, for 6, 7, 8, 9 and 10 inch truck tires.

### NEW HERSCHELL-SPILLMAN ENGINE

**THE Herschell-Spillman Motor Co.**, North Tonawanda, N.Y., announce anew 3½ x 5 in. motor. The new engine is known as the H.S. Model 7000, Type 1. It is L-head, cast in block with detachable cylinder head. The intake and exhaust manifolds are cast integral and are so arranged that when gasoline passes through the intake pipe it is heated by the exhaust pipe walls to such an extent that it generates a gas by the time it reaches the combustion chamber. The engine is of the three point suspension type and rear supporting arms are especially strong. The forward end is supported at crank centre.

The valve mechanism is enclosed and operated by a single camshaft. Both inlet and exhaust valves are of liberal size, having an effective working diameter of 1¾ in. with a clear opening of 1 9-16 and are interchangeable. The pushrods are of special alloy steel ¾ in. diameter and revolve in cast iron bearings.

The piston is cast from grey iron, ground to size, provided with special recesses and drilled with relief holes to prevent the motor smoking. Piston rings are of one piece construction diagonally split and accurately machined and fitted to the pistons.

The connecting rods are 11 in. in length from centre to centre and are "I" beam section drop forged type of two bolt cap construction. The cooling system is thermo-syphon and the oiling system is combination force feed and splash. Full force pressure feed to main crank shaft and camshaft bearings. Splash to the upper and lower rod bearings and cylinders. Starting, lighting and ignition is standard S.A.E. equipment.

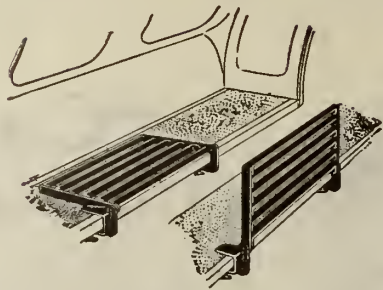

Safety Tread.

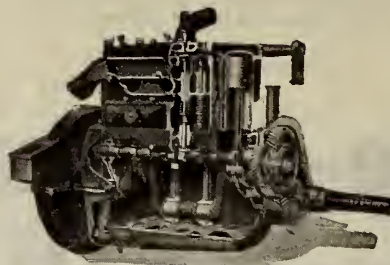

New Herschell-Spillman Engine

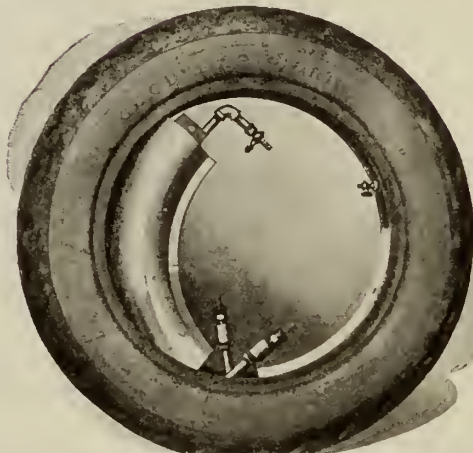

P.I.W. Vulcanizer.

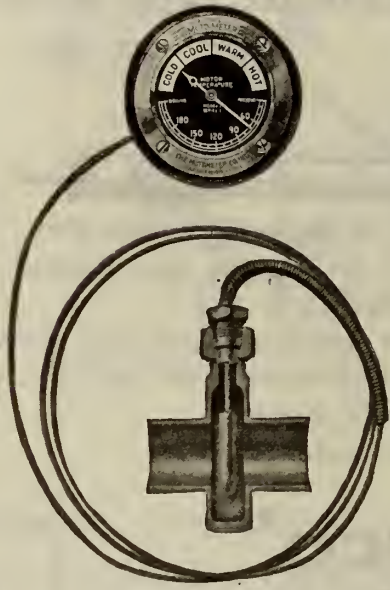

Distance Type Moto-Meter

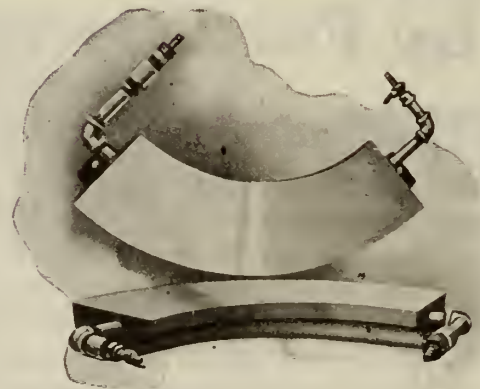

P.I.W. Vulcanizer.



Liberty Spark Plug

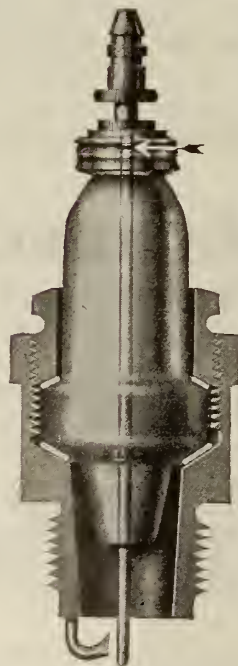

Vacuum Fire Plug

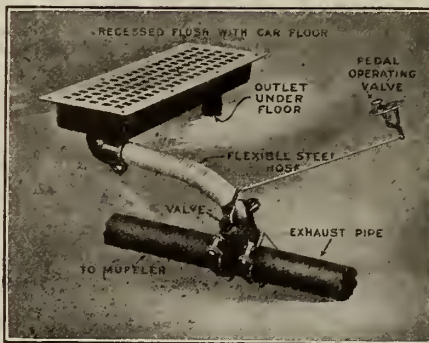

Eureka Car Heater

### DISTANCE TYPE MOTO-METER

**THE** Distance Type Boyce Moto-Meter, model "A" is especially designed for installations where the radiator type instrument can not be installed on a line with the operator's vision, as on airplanes, motor boats, stationary engines, tractors and for laboratory testing purposes. It is finished with black enamel case—3 5-16 inches in diameter—nickel plated rings, bevelled crystal, and red and white pointer. Reinforced flexible brass tubing is used four inches from bulb-end. The temperature ranges from 32° to 212° F. Complete with 5 feet of tubing and hose couplings.

To install it is only necessary, the makers say, to cut away one inch of the hose on the outlet pipe of the motor, between the motor and radiator. It is manufactured by the Moto-Meter Co., Inc., Long Island City, New York.

### VACUUM FIRE PLUG

**A** SPARK plug especially designed for tractors, trucks and high-powered motor cars recently was perfected by the Penn Manufacturing Company, 319 West Ninth Street, Kansas City, Missouri, and is being marketed under the brand name of Vacuum-Fire. The name was given the plug because its jump-gap spark, by which the flame is intensified manifold, is gained in a vacuum chamber built into the head of the plug, thus being free of atmospheric pressure.

The fire is delivered from a wide point, which spreads it. The intensity and "fatness" of the flame, according to the makers of the plug, burns poor mixtures as readily as good ones and prevents missing, skipping and back-firing. A feature new to spark plugs, and which will tend to make it favored by motor boatmen is that all its steel parts are Parkerized. The Parker process was developed during the war and was used by the United States government to prevent rust on war materials, notably cartridge clips and bayonets. It is equipped with 775 porcelains.

### EUREKA CAR HEATER

**THE** Eureka Accessory Co., 404 Dollar Bank Bldg., Youngstown, O., has placed on the market a device for heating automobiles in all kinds of weather. The makers say, in the Eureka heater, they have found a sanitary system of heating with pure, fresh air. The heater uses the exhaust gas, passing it through flexible tubing to the floor plate which is 7 x 21 in. The gas then passes through the length of the floor plate and is exhausted through a pipe outlet under the floor of the car. The gas directed to the car is regulated by the control valve, operated by a rod and a foot lever, conveniently arranged. The heater is made of aluminum and pressed steel, finished in nickel. It is light in weight, durable and of good appearance.

### LIBERTY SPARK PLUG

**LIBERTY** Spark Plugs are said to deliver a hotter, more penetrating spark, largely due to an improved and patented spark gap intensifier. This intensifier is built right into the porcelain assembly where it cannot come out of adjustment or cause trouble. The gap is perfectly adjusted for giving the proper intensifying of the electric current. It is neither too great to throw strain on your ignition system or too small to get the proper intensity into the spark. It is claimed that Liberty Spark Plugs make starting easier and stop missing and skipping caused by compression, killing the spark in the cylinder. Also they will fire in carbon and oil where other plugs foul out in a short time. Liberty Spark Plugs are packed 4 or 6 to the box instead of separately as is usually the case. Full information can be secured by writing Casey Hudson Company, 361 E. Ohio Street, Chicago, Ill.



# These Ads. Will Help You Sell Massey Harris Implements

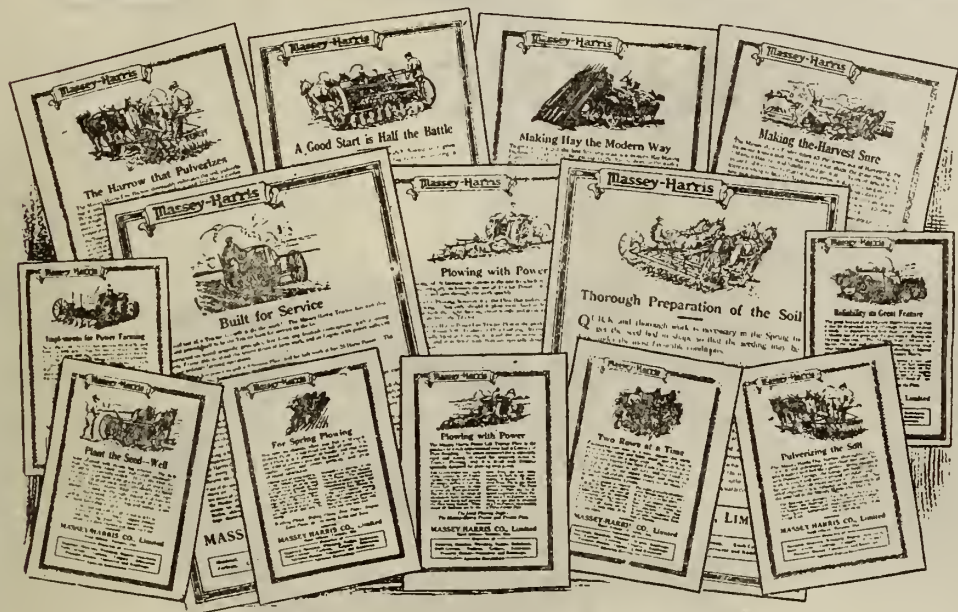

The advertisements here reproduced are a few of a series now appearing in all of the leading Farm Papers.

Every Implement Dealer realizes how much easier it is to sell a well-advertised line of implements. This is because the "Prospect's" mind has been favorably impressed by the reading of the ads., and in fact, in many cases, the reading of the ads. creates your "Prospect."

This Farm Paper Series, together with our Direct-by-Mail Advertising, consisting of numerous attractive folders, are a powerful factor in preparing the way for the Massey-Harris agent, and making it easy to sell Massey-Harris Implements.

No need to explain who Massey-Harris is, and what the name stands for. It is known to all farmers and stands for the best in farm Implements, and has done so for generations.

Head Office  
Toronto

**Massey-Harris Co, Limited,**

Factories at  
Toronto Brantford (2)  
Woodstock Weston

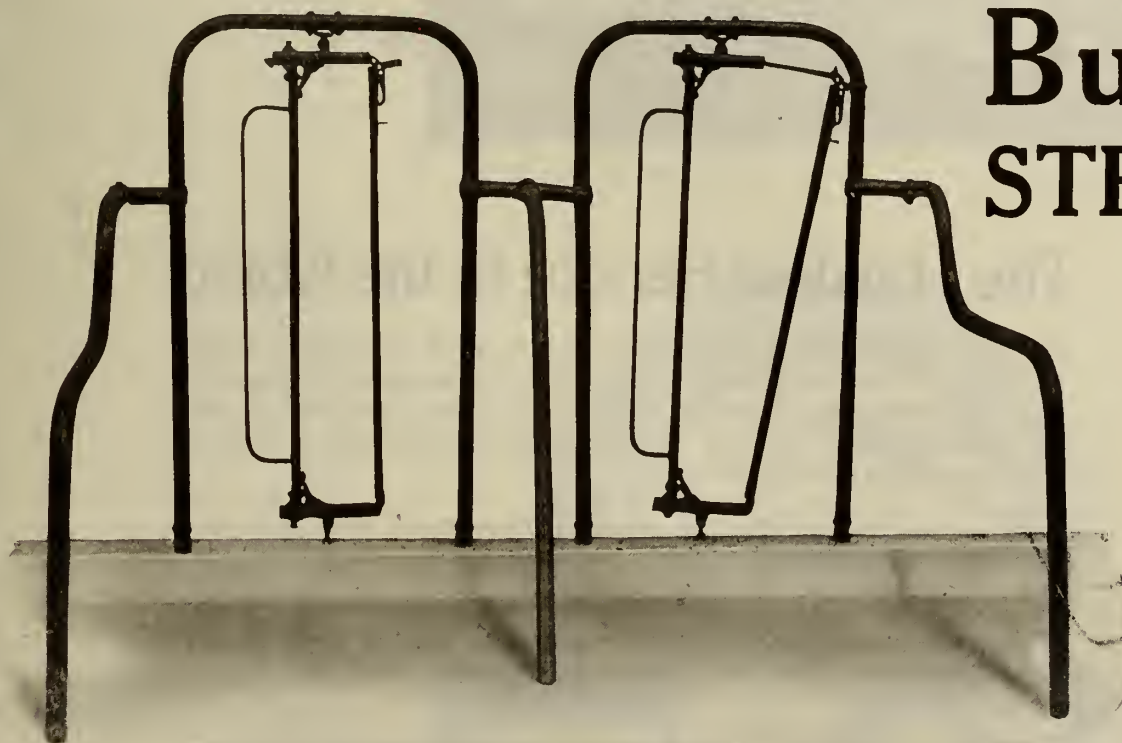

## Buchanan's STEEL STALLS

SELL

easier than any others  
**BECAUSE**

They make the stable look like a show stable.

They make no noise and clang in the stable as do the head rail stalls.

All spaces are filled so that the cattle cannot get their head in the wrong place instead of going into the stanchion.

The stanchion is adjustable for any sized cattle.

The stanchion is locked by a steel lock, not by a wire spring.

**AND**

Buchanan's line of Haying Tools including wood track, steel track, rod track, and cable carriers, slings, forks, etc., have been the farmers' friends for over forty years. You will be asked for Buchanan's Haying Tools. Then too, you will find our prices on our goods are so reasonable that you can always more than compete with your opposition.

*We give most liberal discounts to agents. It means more business and more profit to you to be a Buchanan agent. We want to send you our agency proposition. May we?*

Write to **M. T. BUCHANAN & CO., Ingersoll, Ontario**



# HYATT

## ROLLER BEARINGS

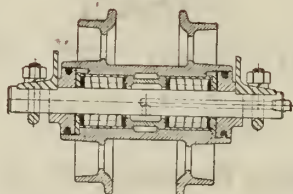
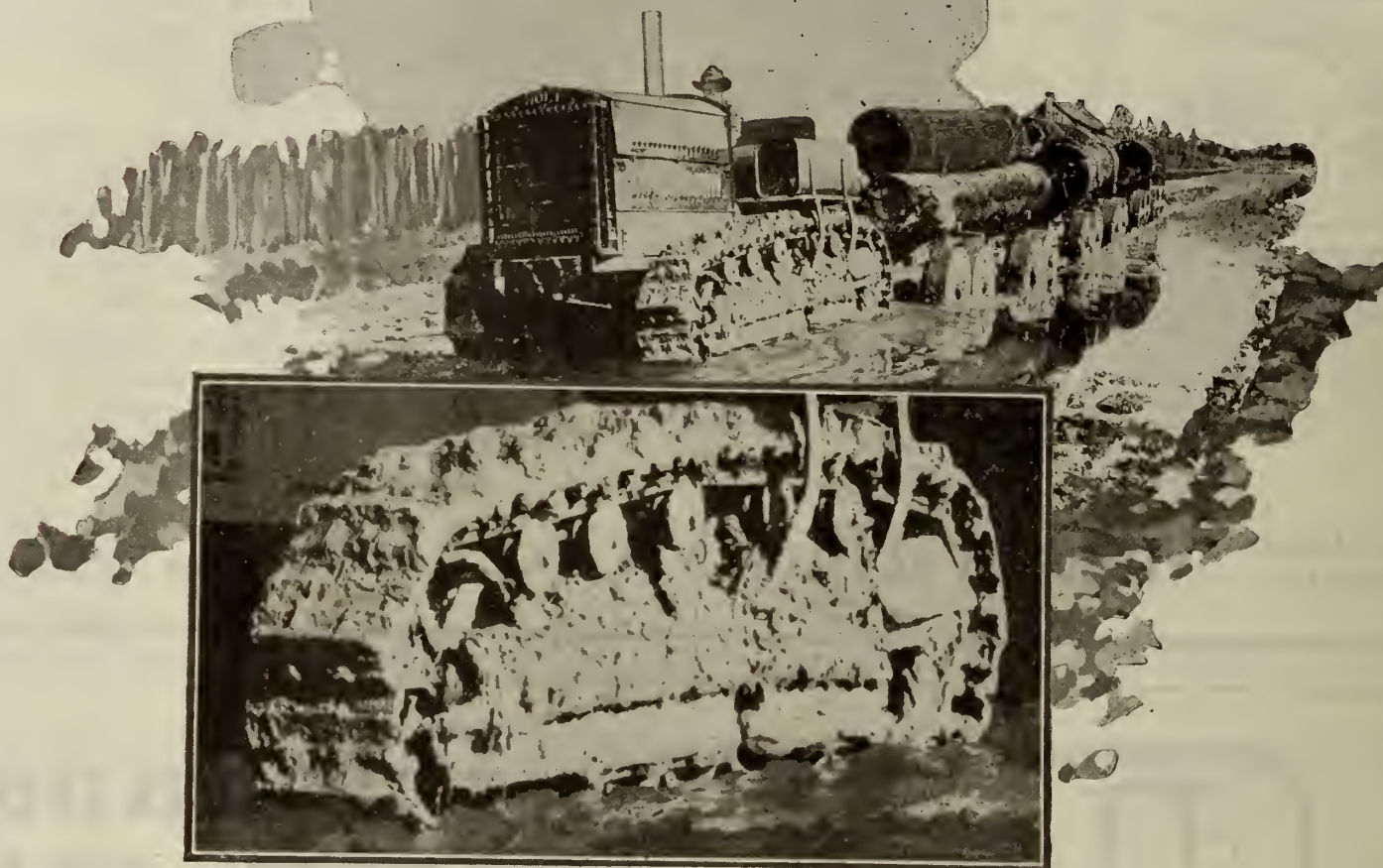

Cross Sectional View of a Track Roller in Creeper Type Tractors Showing Application of Hyatt Roller Bearings.

In this position the hollow spiral roller construction of Hyatt Roller Bearings provides many distinct advantages.

Only a bearing of the Hyatt type can stand up and give permanent performance under the gruelling conditions of track roller operation.

The resilient Hyatt rollers lessen the tremendous shocks—eliminate breakage—provide efficient lubrication even under extreme conditions—and always "stay put" assuring constant operation without stops for repairs.

It is because of these many peculiar advantages that Hyatt Roller Bearings are just as permanent as the shafts upon which they operate.

## The Hardest Service in the World

Forcing their way through mud, muck, sand or water—going through or over all obstructions and, at the same time, supporting the tremendous weight and pull of this giant tractor and its load, the track wheels of the "creeper" type tractor endure the hardest service in the world.

And, at the point of severest wear in these track wheels, Hyatt Bearings are installed.

Ten years ago, Hyatts were first used in this application. Many of these old machines are still in operation, and in them Hyatt Bearings have given ten years of constantly dependable, permanent service.

Ten years' use under the most severe working conditions known in the tractor industry, without ever requiring adjustment.

There could be no greater proof that Hyatt Bearings should be in the tractor you buy, or in the truck, thresher, grain binder, plow, windmill and other farm machinery.

**HYATT ROLLER BEARING COMPANY**

Tractor Bearings Division, Chicago

Motor Bearings Division, Detroit

Industrial Bearings Div., New York City



**WEISTEEL FENDERS AND CANOPY**

THIS equipment, manufactured by the Henry Weis Manufacturing Co., Atchison, Kansas, incorporates the features that make for strength, durability and appearance. The makers say the fenders are built of extra heavy material and are designed for the Fordson tractor. The top of the fender is fastened to the side by a double seaming process; the outside edge is finished with a heavy iron rod rolled right into the fender. The bottom is reinforced by heavy band iron, and the axle clamp is of heavy malleable iron. The rear bracing is attached to the cap screws in the differential case, and offers no obstruction to the operator.

The fenders are supported entirely on a steel frame to which the sheet metal of the fenders is riveted.

The canopy frame is of hard wood, bent to shape and covered with 8 oz. khaki duck; this is supported on heavy steel tubing. There are no holes to drill, a wrench and a screw driver does the job in 30 minutes. It is not necessary to remove the fenders to do belt work as there is no interference with the belt pulley. The entire equipment is painted grey to match the tractor.



Weisteel Fenders and Canopy.

**HIGH-RATE DISCHARGE INSTRUMENT**

THE John O. Heinze Co., Springfield, Ohio, has put on the market an instrument for detecting discharged battery cells, known as the High-Rate Discharge Instrument. It is designed for use in the garage and service station. It consists of a voltmeter with a centre reading 2-0-2, graduated in tenths. This is mounted on two steel posts which terminate in a convenient handle. Between these, the current is short-circuited through a fixed resistance which determines the rate of discharge. The resistance has a current capacity of 80 amperes cold and 70 amperes when hot.

When a cell is in good condition—the makers say—the voltmeter needle will register a position somewhere between 1.3 and 1.7. It will not register higher because the high-rate discharge produces an immediate drop in the voltage. If the cell has defective insulation, the needle will gradually recede towards the centre. If the cell has broken connectors or an open circuit, the needle will remain at zero. Tests are quickly made, from ten to twenty seconds should suffice.

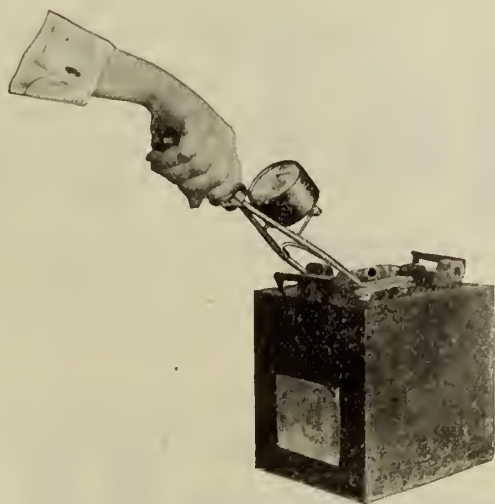

High-rate Discharge Instrument.



Radiator Cement.



Flexible Carbon Scrapers.

**K.P. UNIVERSAL RIM TOOL**

THIS tool, manufactured by the K. P. Products Co., Inc., 250 West 54th street, New York, is designed for the easy operation of all transversely split rims. It fits all sizes and makes and locks the rims in a collapsed position while the tire is being removed or replaced. The makers say on the Baker type of rim it pulls the joint down and sideways so as to clear the valve stem. It opens the joint of rims that use an interlock. It will force the rim back together and in alignment for locking on all rims. There is no danger of springing the rim out of shape or of pinching the tube, as no tools are required to force the tire over the rim.



Tool Locked in Position for Removing or Replacing Tire

K.P. Universal Rim Tool

**FLEXIBLE CARBON SCRAPERS**

THE Flexible Carbon Scraper Co., Los Angeles, California, are manufacturing carbon scrapers for use in the garage and service station. They are made of spring steel wire, the makers say, are flexible as whale bone, and easily reach all parts of the combustion chamber through the valve cap openings, and in overhead valve motors, through the spark plug openings. The scraping members are six spring steel fingers that conform to the shape of the surface to be scraped and clean a path the entire width of the tool. They do the work without taking the motor down. The scrapers are composed of sets of three tools, and are made in two sizes. The No. 1 set is for small bore motors, and No. 2 is for larger motors.



Battery Tester.

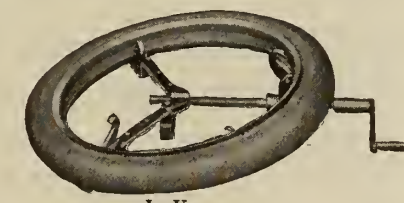

In Use.

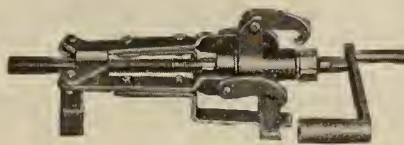

Closed

**RADIATOR CEMENT**

THIS radiator cement, manufactured by the Canadian Durkee Atwood Co., Ltd., Toronto, forms a seal to withstand the jar of rough roads, the makers say, and when left in the radiator automatically seals any new leaks which may develop. It keeps the radiator free from rust and scale formations and works effectively in alcohol or any other form of anti-freezing solution.

**BATTERY TESTER**

THE Service Station Supply Company 32 E. Larned St., Detroit, Mich., are placing on the Canadian market a new battery tester under the trade name of Hyrate. The manufacturers claim that the Hyrate tester can be held in one hand and contact obtained by touching the point of the prods into the posts or straps across one cell.

The Hyrate cell tester consists of two hexagon special steel prods, 3 inches apart at the point, with upper end assembled in the handle. A nickel-chromium resistance of .01 ohm. connects the prod. Suspended on prods between the prods is located a volt meter with volt scale. This meter is of the moving coil type and is strongly constructed of high grade materials.

The Hyrate tester, can be used with any make of battery and comes packed complete, including a Hyrate volt meter.

**SPLIT RIM TOOL**

THE Marquette Manufacturing Co., Inc., St. Paul, Minn., are placing on the market a new tool for removing tires from split rims, which goes under the trade name of Little Giant, which they claim, is efficient, dependable, light strong, simply made and easy to operate. The makers state that the split rim is unlocked by a few turns of the handle, which contracts the rim so that the tire is readily lifted off. The tire is readily expanded to the locking point by a reverse motion of the handle.

The centre bracket at the throat of the "Y" is furnished with a hole through which the tool may be bolted to bench or stand if it is desired to use it as a stationary appliance—at the same time its lightness and collapsible design make it practicable for use on the floor or road beside the car.

They also claim that this method of removing tires will eliminate the danger of pinching or cutting inner tubes, and that it is equally serviceable for garages as for private car owners.

**NON-BURSTABLE RADIATOR**

GUARANTEE SHEET METAL & ROOFING CO., Winnipeg, are marketing the Perfecto, non-burstable radiator for Ford cars. Agencies are being established among the trade in the sale of this product. The radiator is built on scientific principles, having flat tubes with spring brass fins between which give and take with the expansion and contraction resultant from the freezing of the liquid in the radiator. This is the principle on which the radiator is claimed to be safe from bursting when frozen.

**LEAGUE OF NATIONS TO FIX PRICES**

EXISTING prices of gasoline are condemned as "grossly excessive" in a report submitted by a committee appointed under the profiteering act to investigate prices. It says the concentration of control of the supply in hands of enormously powerful combines constitutes such a dangerous power, if improperly used, that it is imperative that governments should give attention to it. Recommendation is made that oil prices be regulated by the League of Nations under international agreement.

The Standard Oil Company and the Shell Corporation are named in the report as the combines mainly concerned.



# CANADIAN Motor, Tractor and Implement Trade Journal BUYERS DIRECTORY

This directory will help you with your buying and your planning. The advertisers listed here are thoroughly reliable and leaders in their respective fields. They are looking for live, wide-awake representatives. Study their advertisements carefully because they contain valuable information which will dovetail with your plans. We are glad to go to the trouble of arranging this list—to make it easy for you to select new lines. If it so happens that what you want is not here, write us, and we will tell you where to get it.

## ACCESSORIES

Northern Electric Co., Ltd., Montreal.  
Universal Tool Co., Inc., Detroit, Mich.  
Windsor Machine & Tool Works, Windsor, Ont.  
Champion Spark Plug Co., Windsor, O.  
G. H. Broughton & Co., Toronto.  
The Goodyear Tire & Rubber Co. of Canada, Ltd., Toronto.  
Chapman Double Ball Bearings Co., of Canada, Toronto.  
R. F. Sedgely, Inc., Philadelphia, Pa.  
The Burrowes Mfg. Co., Ltd., Toronto.  
Can. Fairbanks-Morse Co., Ltd., Montreal.  
Kales Stamping Co., Detroit, Mich.  
Kinzinger Bruce Co., Niagara Falls, O.  
The Greb Co., Boston.  
Casco Mfg. Co., Thomasville, Ga., U.S.A.  
Robinson Co. Ltd., Edward A., Montreal

## AUTOMOBILE CHAINS

Can. Fairbanks-Morse Co., Ltd., Montreal.

## BARN EQUIPMENT

Beatty Bros., Ltd., Fergus, Ont.

## BEAN MACHINERY

John Deere Mfg. Co., Welland, Ont.

## BEET MACHINERY

International Harvester Co., of Can., Ltd., Hamilton, Ont.  
John Deere Mfg. Co., Welland, Ont.

## BINDERS

The Frost & Wood Co., Ltd., Smiths Falls, Ont.  
International Harvester Co., of Can., Ltd., Hamilton, Ont.  
Massey-Harris Co., Toronto.

## BELTING

The Goodyear Tire & Rubber Co. of Canada, Ltd., Toronto.

## BATTERIES

Can. Fairbanks-Morse Co., Ltd., Montreal.

## CARRIAGES

Cockshutt Plow Co., Brantford, Ont.

## CREAM SEPARATORS

De Laval Co., Ltd., Peterboro, Ont.  
International Harvester Co., of Can., Ltd., Hamilton, Ont.  
King Separator Co., Bridgeburg, Ont.  
R. A. Lister Co. (Canada), Ltd., Toronto  
Sharples Separator Co., Toronto.  
Swedish Separator Co., Montreal.

## CEMENT MIXERS

Can. Fairbanks-Morse Co., Ltd., Montreal.

## CASTINGS

Joliette Steel Co., Joliette, P.Q.

## CORN HARVESTERS

Cockshutt Plow Co., Brantford, Ont.  
International Harvester Co., of Can., Ltd., Hamilton, Ont.  
Massey-Harris Co., Toronto.

## CORN MACHINERY

International Harvester Co., of Can., Ltd., Hamilton, Ont.  
John Deere Mfg. Co., Welland, Ont.

## CULTIVATORS

Cockshutt Plow Co., Brantford, Ont.  
John Deere Mfg. Co., Welland, Ont.  
Massey-Harris Co., Toronto.  
The Frost & Wood Co., Ltd., Smiths Falls, Ont.  
International Harvester Co., of Can., Ltd., Hamilton, Ont.

## CUTTERS

Butterfield & Co., Inc., Rock Island, Q.

## DAIRY SUPPLIES

International Harvester Co., of Can., Ltd., Hamilton, Ont.  
R. A. Lister Co. (Canada), Ltd., Toronto

## DIES

Butterfield & Co., Inc., Rock Island, Q.

## DISCS

Massey-Harris Co., Toronto.

## DITCHING MACHINES

Can. Fairbanks-Morse Co., Ltd., Montreal.

## DRILLS

Massey-Harris Co., Toronto.

## DRILLS, TWIST

Butterfield & Co., Inc., Rock Island, Q.

## DRILLS, GRAIN

Cockshutt Plow Co., Brantford, Ont.  
International Harvester Co., of Can., Ltd., Hamilton, Ont.  
John Deere Mfg. Co., Welland, Ont.  
The Frost & Wood Co., Ltd., Smiths Falls, Ont.

## ENGINES

Can. Fairbanks-Morse Co., Ltd., Montreal.  
Gilson Mfg. Co., Ltd., Guelph, Ont.  
International Harvester Co., of Can., Ltd., Hamilton, Ont.  
John Deere Mfg. Co., Welland, Ont.  
The Frost & Wood Co., Ltd., Smiths Falls, Ont.  
Massey-Harris Co., Toronto.  
R. A. Lister Co. (Canada), Ltd., Toronto  
Fisher, Wilkie, Ltd., Sandwich, Ont.  
Sharples Separator Co., Toronto.

## ENSILAGE CUTTERS

Can. Fairbanks-Morse Co., Ltd., Montreal.  
International Harvester Co., of Can., Ltd., Hamilton, Ont.  
Massey-Harris Co., Toronto.

## FEEDERS

John Deere Mfg. Co., Welland, Ont.

## FARM MACHINERY

Can. Fairbanks-Morse Co., Ltd., Montreal.  
Cockshutt Plow Co., Brantford, Ont.  
Fisher, Wilkie, Ltd., Sandwich, Ont.  
John Deere Mfg. Co., Welland, Ont.  
International Harvester Co., of Can., Ltd., Hamilton, Ont.  
Massey-Harris Co., Toronto.  
The Frost & Wood Co., Ltd., Smiths Falls, Ont.  
R. A. Lister Co. (Canada), Ltd., Toronto

## FEED CUTTERS

Can. Fairbanks-Morse Co., Ltd., Montreal.  
Massey-Harris Co., Toronto.

## FENCING

The Steel Company of Canada, Ltd., Montreal, Que.

## FINANCIAL

The Commercial Credit Co. of Canada, Ltd., Toronto.

## GARAGE EQUIPMENT

Universal Tool Co., Inc., Detroit, Mich.  
Windsor Machine & Tool Works, Windsor, Ont.

## GRINDSTONES

S. Vessot & Co., Joliette, P.Q.

## GRINDERS

Can. Fairbanks-Morse Co., Ltd., Montreal.  
International Harvester Co., of Can., Ltd., Hamilton, Ont.  
Massey-Harris Co., Toronto.  
R. A. Lister Co. (Canada), Ltd., Toronto  
S. Vessot & Co., Joliette, P.Q.

## HARROWS

Cockshutt Plow Co., Brantford, Ont.  
International Harvester Co., of Can., Ltd., Hamilton, Ont.  
John Deere Mfg. Co., Welland, Ont.  
Massey-Harris Co., Toronto.  
The Frost & Wood Co., Ltd., Smiths Falls, Ont.

## HAY LOADERS

International Harvester Co., of Can., Ltd., Hamilton, Ont.  
John Deere Mfg. Co., Welland, Ont.  
The Frost & Wood Co., Ltd., Smiths Falls, Ont.

## HARDWARE

Can. Fairbanks-Morse Co., Ltd., Montreal.  
Massey-Harris Co., Toronto.

## HAY RAKES

John Deere Mfg. Co., Welland, Ont.  
The Frost & Wood Co., Ltd., Smiths Falls, Ont.

## HAY CARRIERS

Beatty Bros., Ltd., Fergus, Ont.  
Massey-Harris Co., Toronto.  
M. T. Buchanan & Co., Ingersoll, Ont.

## HAY PRESSES

Birdsell Mfg. Co., Toronto.  
International Harvester Co., of Can., Ltd., Hamilton, Ont.

## HULLERS (Clover)

Birdsell Mfg. Co., Toronto.

## LIGHTNING SYSTEMS

Can. Fairbanks-Morse Co., Ltd., Montreal.

R. A. Lister Co. (Canada), Ltd., Toronto  
Northern Electric Co., Ltd., Montreal.

## LIME AND FERTILIZER SOWERS

John Deere Mfg. Co., Welland, Ont.

## MANURE CARRIERS

Beatty Bros., Ltd., Fergus, Ont.

## MANURE SPREADERS

Cockshutt Plow Co., Brantford, Ont.  
International Harvester Co., of Can., Ltd., Hamilton, Ont.  
John Deere Mfg. Co., Welland, Ont.  
Massey-Harris Co., Toronto.  
The Frost & Wood Co., Ltd., Smiths Falls, Ont.

## MARINE FITTINGS

Northern Electric Co., Ltd., Montreal.

## MOWERS

Cockshutt Plow Co., Brantford, Ont.  
International Harvester Co., of Can., Ltd., Hamilton, Ont.  
Massey-Harris Co., Toronto.  
The Frost & Wood Co., Ltd., Smiths Falls, Ont.

## MILITARY AND GOVERNMENT STORES

War Purchasing Commission, Ottawa.

## MILKING MACHINES

R. A. Lister Co. (Canada), Ltd., Toronto  
Sharples Separator Co., Toronto.  
The Macartney Milking Machine Co., Ltd., Ottawa, Ont.

## MILLING CUTTERS

Butterfield & Co., Inc., Rock Island, Q.

## NUT LOCKS

Robinson Co., Ltd., Ed. A., Montreal.

## PISTON RINGS

WedgeRite Piston Ring Co., Ltd., Montreal.

## PLOWS

Cockshutt Plow Co., Brantford, Ont.  
John Deere Mfg. Co., Welland, Ont.  
The Frost & Wood Co., Ltd., Smiths Falls, Ont.  
International Harvester Co., of Can., Ltd., Hamilton, Ont.  
Massey-Harris Co., Toronto.

## POLICE AND FIRE ALARM EQUIPMENT

Northern Electric Co., Ltd., Montreal.

## POWER AND LIGHT EQUIPMENT

Northern Electric Co., Ltd., Montreal.

## POWER MACHINERY

Can. Fairbanks-Morse Co., Ltd., Montreal.  
John Deere Mfg. Co., Welland, Ont.  
Massey-Harris Co., Toronto.  
International Harvester Co., of Can., Ltd., Hamilton, Ont.

## POWER SWITCHBOARDS

Northern Electric Co., Ltd., Montreal.

## POTATO MACHINERY

John Deere Mfg. Co., Welland, Ont.  
Cockshutt Plow Co., Brantford, Ont.

## PULVERIZERS

Cockshutt Plow Co., Brantford, Ont.  
International Harvester Co., of Can., Ltd., Hamilton, Ont.

## PULPERS

Cockshutt Plow Co., Brantford, Ont.

## RAKES

International Harvester Co., of Can., Ltd., Hamilton, Ont.  
The Frost & Wood Co., Ltd., Smiths Falls, Ont.

## REAPERS

International Harvester Co., of Can., Ltd., Hamilton, Ont.  
The Frost & Wood Co., Ltd., Smiths Falls, Ont.

## REAMERS

Butterfield & Co., Inc., Rock Island, Q.

## ROLLERS

Cockshutt Plow Co., Brantford, Ont.  
Massey-Harris Co., Toronto.  
Hyatt Roller Bearing Co., Chicago.

## ROLLER BEARINGS

Hyatt Roller Bearing Co., Chicago.

## SAFES

J. & J. Taylor, Ltd., Toronto.

## SAW MILL OUTFITS

Massey-Harris Co., Toronto.

## SCUFFLERS

Cockshutt Plow Co., Brantford, Ont.  
International Harvester Co., of Can., Ltd., Hamilton, Ont.  
John Deere Mfg. Co., Welland, Ont.

## SEEDERS

Massey-Harris Co., Toronto.

## SCREW PLATES

Butterfield & Co., Inc., Rock Island, Q.

## STABLE EQUIPMENT

Beatty Bros., Ltd., Fergus, Ont.  
M. T. Buchanan & Co., Ingersoll, Ont.

## SILOS

Gilson Mfg. Co., Guelph, Ont.

## SLEIGHS

Cockshutt Plow Co., Brantford, Ont.  
International Harvester Co., of Can., Ltd., Hamilton, Ont.

## SILO FILLERS

Gilson Mfg. Co., Guelph, Ont.  
International Harvester Co., of Can., Ltd., Hamilton, Ont.

## SOCKET WRENCHES

R. F. Sedgely, Inc., Philadelphia, Pa.

## SPREADERS, MANURE

Cockshutt Plow Co., Brantford, Ont.  
John Deere Mfg. Co., Welland, Ont.  
International Harvester Co., of Can., Ltd., Hamilton, Ont.  
Massey-Harris Co., Toronto.

## SPARK PLUGS

Champion Spark Plug Co., Windsor, O.

## SPARK PLUG CLEANERS

Champion Spark Plug Co., Windsor, O.

## TELEPHONE APPARATUS

Northern Electric Co., Ltd., Montreal.

## TIRES

The Goodyear Tire & Rubber Co. of Canada, Ltd., Toronto.

## TRACTORS

Advance-Rumely Thresher Co., La Porte, Ind.  
R. A. Lister Co. (Canada), Ltd., Toronto  
Can. Allis-Chalmers, Ltd., Toronto.  
Cleveland Tractor Co., Windsor, Ont.  
Gilson Mfg. Co., Guelph, Ont.  
International Harvester Co., of Can., Ltd., Hamilton, Ont.  
J. I. Case Threshing Machine Co., Inc., Racine, Wis.  
Massey-Harris Co., Toronto.  
The Gray Tractor Co. of Canada, Ltd., Winnipeg.  
The Turner Mfg. Co., Port Washington, Wis.

## TRACTOR PLOWS

Cockshutt Plow Co., Brantford, Ont.  
International Harvester Co., of Can., Ltd., Hamilton, Ont.  
John Deere Mfg. Co., Welland, Ont.  
Massey-Harris Co., Toronto.

## THRESHERS

Can. Fairbanks-Morse Co., Ltd., Montreal.  
International Harvester Co., of Can., Ltd., Hamilton, Ont.  
J. I. Case Threshing Machine Co., Inc., Racine, Wis.  
R. A. Lister Co. (Canada), Ltd., Toronto

## THREAD CUTTING TAPS

Butterfield & Co., Inc., Rock Island, Q.

## TWIST DRILLS

Butterfield & Co., Inc., Rock Island, Q.

## TRUCKS

Beaver Truck Builders, Ltd., Hamilton  
Eastern Canada Motor Truck Co., Ltd., Hull, P.Q.  
International Harvester Co., of Can., Ltd., Hamilton, Ont.

## WHEELBARROWS

Cockshutt Plow Co., Brantford, Ont.  
Massey-Harris Co., Toronto.

## WAGONS

Cockshutt Plow Co., Brantford, Ont.  
International Harvester Co., of Can., Ltd., Hamilton, Ont.  
Massey-Harris Co., Toronto.

## WATER BOWLS

Beatty Bros., Ltd., Fergus, Ont.

## WEEDERS

Cockshutt Plow Co., Brantford, Ont.

## WIRES AND CABLES

Northern Electric Co., Ltd., Montreal.



Butterfield

Tools That Retain  
Their Keen Edges  
After Long Usage

Butterfield

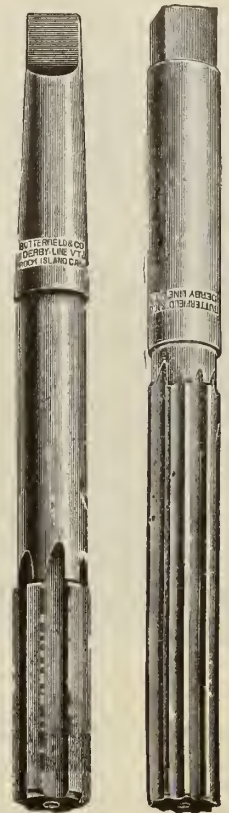

Butterfield  
"THE QUALITY SUPREME"

# Drills, Taps, Dies, Reamers

and Milling Cutters

The paramount quality of Butterfield Tools ensures you a big measure of service—a service that reduces your operating cost and turns this saving into profit.

Next time you need Drills, Taps, Dies, Reamers, or Milling Cutters be sure to try the Butterfield line. Trials invariably result in steady customers.

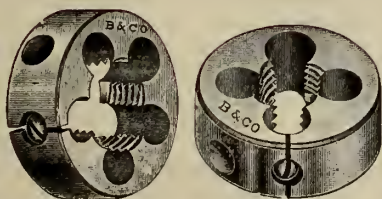
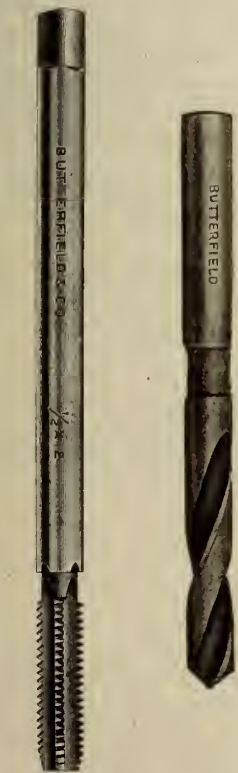

Butterfield & Co., Inc.

Rock Island, Quebec



# TRACTOR FARMING at the O.A.C.

By L. G. HEIMPEL, B.S.A.  
FARM MANAGER



The tractor on belt work filling a silo.

PRIOR to the summer of 1919, very little tractor farming had been attempted on the College farm. The only work done was some plowing which being of inferior quality for such work was of no great credit to the iron horse. It was not till the end of August, last year, that the tractor was given a chance to either make good or go under for all time to come.

There was nothing new or novel about the undertaking. The outfit consisted of a two-cylinder engine—an Ontario Government engine which had seen much hard work and carried the dust of many fields on its once gaudy coat of paint—and a similarly dispirited plow. The argument, however, was that if a tractor can be made to pay at all an old engine should pay as well as a shiny new one, so the engine was partly overhauled. The valves were ground, the bearings tightened, carbon removed from piston ring grooves, the drive chains cleaned, repaired and lubricated and the wobbly front wheels were made to run more nearly true by the insertion of rings of sheet iron in the hubs. Time being at a premium no more was done to it than was necessary to put it in fair "running order." The first job was killing weeds and twitch, by after harvest cultivation, with a stiff tooth cultivator with nine teeth, each of which was equipped with a cutting edge nine inches wide. The ground was hard and to pull those teeth through the ground at the average depth of three inches took more than a small amount of power. By way of comparison four horses were hitched to this cultivator and it was found to be too much of a load for them; even with two teeth removed it was more than they could do to keep it going all day long at the depth the engine pulled it. This gave us some idea of the quality of work the engine was doing.

Some of the stubble ground was double disced as is shown by the table below and since the discs were the same width as the cultivator the two are dealt with as though they were the same operation. The gang was made up of an out-throw and in-throw disc hitched tandem behind the engine. By loading them down with bags of soil and setting them "in the last notch" we were able to get good results even in fairly hard ground. Here again the advantage of unlimited power as compared with horse-power was very marked.

THE following table is a cost statement of the after-harvest cultivation:

Number of acres cultivated .....	63
Number of acres double disced .....	50
<b>Total acreage .....</b>	<b>113</b>

Operator's wages for 138 hrs. at 30c..	\$ 41.40
Fuel—162 gals. kerosene at 21½c.....	34.83
6 " gasoline at 35c.....	2.10
12 " cylinder oil at 65c....	7.80
4 lbs. grease at 25c.....	1.00
Interest at 6 per cent. and depreciation on outfit at 15 per cent.....	13.11
Foreman's time overhauling and repairs	7.72
	<b>\$107.96</b>

Therefore cost per acre for after-harvest cultivation is  $\frac{107.96}{113} = 94.8$  cents an acre.

As the only fair way to distribute interest, depreciation, overhauling and repair costs is to spread it over total number of days the machine was at work, this is what has been done in the above items:

Value of outfit \$700.00	
Total number of days the engine worked in season of five months is 64.5 days.	
Interest on \$700.00 at 6% for 5 months =	\$17.50
Depreciation on \$700.00 at 15% for 5 months .....	= 43.75
<b>Total</b>	<b>\$61.25</b>

This averaged over 64.5 days = 95c per day  
The same method was followed in allotting overhauling and repair expenses:

Foreman's time overhauling, 30 hrs. at 40c	\$12.00
Repairs for engine and outfit .....	24.00
	<b>\$36.00</b>

Over 64.5 days this amounts to 56c a day.  
Operator's wages includes all wages paid to operator while on this work, whether moving or stopping.

There is nothing marvellous in the speed with which this work was accomplished; almost fourteen days being required to finish it. The redeeming features are the low cost at which it was done, the fact that the tractor made the doing of it possible when it was impossible to do it with horses owing to the press of harvest operations, and the fact that the work was done

in days when the heat was so great that horses would have made very poor progress in such work.

## The Tractor in Fall Plowing

WHEN the time came for the opening of fall plowing operations the tractor was again put to work. It pulled a three-furrow plow, twelve-inch furrows, and though the operator was a "green" tractor-man the quality of the work showed that he was a well matured plowman. It is much easier to learn to drive a tractor than it is to do good work with a plow under adverse conditions. The ground was very hard and dry, yet this did not seem to trouble the outfit very much.

The following table is a summary of the cost of plowing 155 acres of fall plowing:

Number of acres 155.	
Number of day's plowing 45½.	
Operator's wages at 30 cents an hour....	\$136.65
305 gallons kerosene at 21½ cents .....	65.57
37 gallons gasoline at 35 cents .....	12.95
38 gallons cylinder oil at 65 cents....	24.70
6 gallons grease at 25 cents.....	1.50
Interest at 5% and depreciation at 15% for 45½ days at 95 cents a day .....	43.22
Foreman's time when overhauling and repairs at 56 cents per day.....	25.48
<b>Total</b>	<b>\$310.05</b>

Cost per acre =  $\frac{310.05}{155} = \$2.00$  per acre.

According to the above the average day's plowing was less than three and one-half acres per day. This small average is largely due to delays caused by the pressure of land-fast boulders, also by lost time caused by minor engine troubles which could have been prevented by a more experienced operator. Even with this small average per day we are able to show a comparatively small cost per acre. With the advent of a skilled operator, the removal of boulders and with a liberal supply of fuel and water at the operator's hand it will be possible to not only show a higher average of plowing per day, but also a still lower cost per acre.

With large, fairly level fields of regular outline and free from boulders, there is no longer any question as to the possibilities of the tractor. Yet no matter how good the conditions unless the operator knows his engine as thoroughly as a good teamster knows his horses he cannot hope for much success in tractor farming.





## UNQUESTIONABLY "Canada's Lowest Hauling Cost"

**Mr. Dealer,**

The Beaver Agency is a big  
**Money Maker**

The Beaver Truck is the result of actual truck knowledge, based on approved engineering.

It is built on sound engineering practice and built to stand up.

It is built in Canada's largest exclusive truck factory, by men long experienced in the manufacture of motor trucks and who know Canada's transportation problems.

Part of the large saving in duty on American trucks is put into extra built-in value and the balance is deducted from the usual list price of the trucks.

Up-to-date transportation.

*Write for full details and Agency Proposition.*

# Beaver Trucks

*Manufactured in Canada by*

---

**Beaver Truck Builders, Limited, Hamilton, Ont.**

---



# VETERAN

## MOTOR TRUCKS

*Made in Canada*

### POWER, LOW UPKEEP, LONG LIFE

This combination interests the man who has freight to haul

#### Why we use the Zenith Carburetor

The average driver is usually unfamiliar with his car. He knows that if he does certain things, certain things will happen, but he does not know the reason why. If he is inquisitive, he will attempt to find out, usually with disastrous results. It is therefore essential that all working parts be as nearly fool-proof as possible. The Zenith is free from adjustments and is simplicity itself. Its reliability is well known. If the Zenith was not perfect, the British Government would not have used it on practically all our planes.

#### Why we use the Eisemann Ignition

It is poor economy to buy a cheap ignition. The Eisemann is known to be dependable, durable and efficient. The impulse starter insures a hot spark for starting and eliminates a complicated auxiliary battery system. Its efficiency warrants its being used on the Veteran.

#### Why we use the Simplex Governor

A good governor should automatically proportion the power output to the power requirement, within the capacity of the engine; it should leave available at all speeds, every pound of power that the engine can usefully employ and still provide an exact governor control.

This is the second of a series of advertisements running in this paper, explaining our reasons for using certain essentials which go into the Veteran. The advertisement in the February number dealt with the engine and transmission.



2-1/2 Ton Model Complete with Cab and Stake Body

There are two sources of heat in an engine, the burning charge in the cylinder, and friction. All oils have limits of temperature beyond which it is not safe to subject them. Any increase in engine speed, with load, will necessarily result in considerably more heat from the burning charges and give a larger percentage of frictional heat. Therefore it is of vital importance to regulate or govern positively the engine speed. By a careful balancing of the power required and the power developed the efficiency of a truck may be increased 20 per cent. to 50 per cent., as may be shown by well-established records. After thorough investigation and trials, our engineers decided on the Simplex as the most suitable for the Veteran.

## Eastern Canada Motor Truck Co., Limited

### HULL, QUE.



# CANADIAN MOTOR, TRACTOR AND IMPLEMENT TRADE JOURNAL

Published Monthly by THE MACLEAN PUBLISHING COMPANY, LIMITED, TORONTO

MONTREAL, Southam Bldg. WINNIPEG, 1103 Union Trust Bldg. VANCOUVER, 39 10th Ave. West. LONDON, ENG., 88 Fleet St., E.C. 4. NEW YORK, 1133 Broadway. BOSTON, 734 Old South Bldg. CHICAGO, 1401 Lytton Bldg

VOL. II, No. 4

TORONTO, APRIL, 1920

Subscription Price  
\$1.00 Per Year

## Apollo

### SPARKING PLUGS

—are sure and satisfactory sellers!

You're on a good thing when you handle APOLLO PLUGS—they represent the highest standard of BRITISH plug manufacture, are fully tested to ensure maximum efficiency and are guaranteed to give complete satisfaction.

With the APOLLO range of plugs you can promptly meet every plug request—there are models for every type of Car, Motor Truck and Tractor engine—and every plug carries a GOOD PROFIT for YOU.

Super Mica Plug, is specially designed for high-speed, high-compression engines. It is unaffected by excessive heat and of exceptional durability—a plug that gives a quick start and adds power to the engine. Retails in the U.K. at..... **6/-**

Porcelain Plug is specially designed for the FORD engine. It has Solid Brass body, 1/2-in. gas thread, is clean to handle, will not rust, fits the special Ford spanner, is insulated with finest porcelain and is detachable for cleaning. Retails in the U.K. at..... **5/-**

Get on to the APOLLO PLUG proposition and you'll do big business in selling plugs. We can give prompt shipment of all models and supply you with posters, showcards and advertising literature. Write us for trade terms and full particulars of our models.

**APOLLO PLUG MFG. CO.**  
Moseley Street Birmingham, England

Codes: A.B.C. 4th Western Union

Plugs for all engines



APOLLO  
No. 1.  
Super  
Mica  
Plug



APOLLO  
Special



APOLLO  
L.C.B.  
Special  
FORD  
Plug

Overtime  
Tractor  
Plug





## The Wedge Does It

Back of *WedgeRite Piston Rings* is a principle used for ages by woodmen in splitting giant trees. The advance agents of civilization know the value of the *wedge* and increase efficiency by using it. In adapting the *wedge* principle to the construction of piston rings we have solved one of the most troublesome problems facing the motorist. The *WedgeRite Piston Ring* is made up in three sections—two outer or bearing rings and a wedge-shaped ring of untempered spring steel. This spring steel ring is slightly larger than the two outer rings and when placed between them it exerts a constant outward pressure, wedging the outer rings apart and pressing them firmly against the groove walls. *WedgeRite Piston Rings* excel because of this exclusive feature.

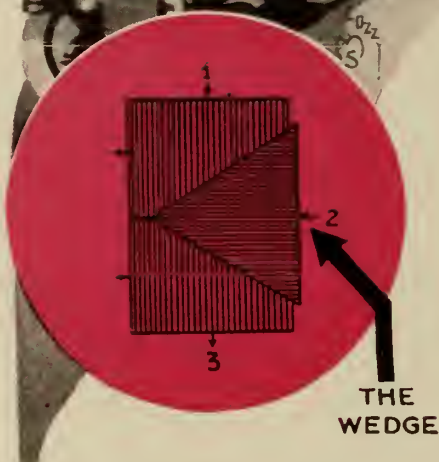

### CROSS SECTION OF RING

1. Section pressing outward and upward.
2. Spring section of ring.
3. Lower outward and downward section.

### ILLUSTRATING THE WEDGE PRINCIPLE

The Wedge principle employed in the making of *WedgeRite Piston Rings* is shown in the accompanying drawing. Its superiority, measured by its ability to expand in WIDTH, as well as in diameter, means utmost satisfaction for motorists.

## More Power—Smoother Operation

*WedgeRite Piston Rings* are power boosters for the farm tractor. Running along the level, over rough ground, or up an incline, *WedgeRite Piston Rings* hold tight giving the engine every ounce of power generated. You cannot do a better stroke of business than sell a farmer friend a set of *WedgeRite*. They will save him money and give him more and smoother power. He will want a set on his motor car, too.

Explain to your customers the principle of *WedgeRite*. It is so obviously correct any user of gasoline power will see it.



**WedgeRite**  
PISTON RING  
COMPANY  
LIMITED

92 Notre Dame St. E., MONTREAL

Order from Your Favourite Jobber



The Name is a  
Guarantee of  
Quality

# POWER ON THE FARM

# Lister

Rousing Sellers  
Everywhere  
Shown

## Three-Power Selling Force!

Sell the line with the reputation—you'll find it is the easiest and best seller always.

The Lister line has behind it: (1) the world-wide British reputation for thoroughness; (2) fifty years

of Lister success in perfecting farm machinery of the highest standard of reliability.

Join these big selling factors up with your own reputation and you have a three-team selling power that will mean big business this season.

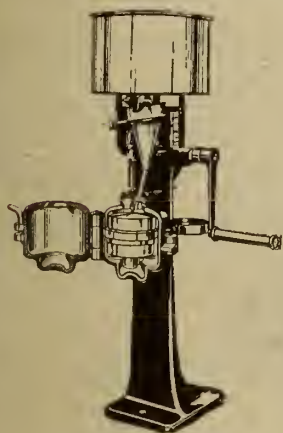

### Melotte Cream Separator

The original Melotte—famous for close-skimming, easy cleaning and easy running. The separator with the self-balancing bowl, the only ball-bearing bowl on the market. It cannot get out of balance, can't cause currents in cream, nor remix cream with milk. Simple, durable—foolproof. Sells on its wonderful reputation for efficiency.

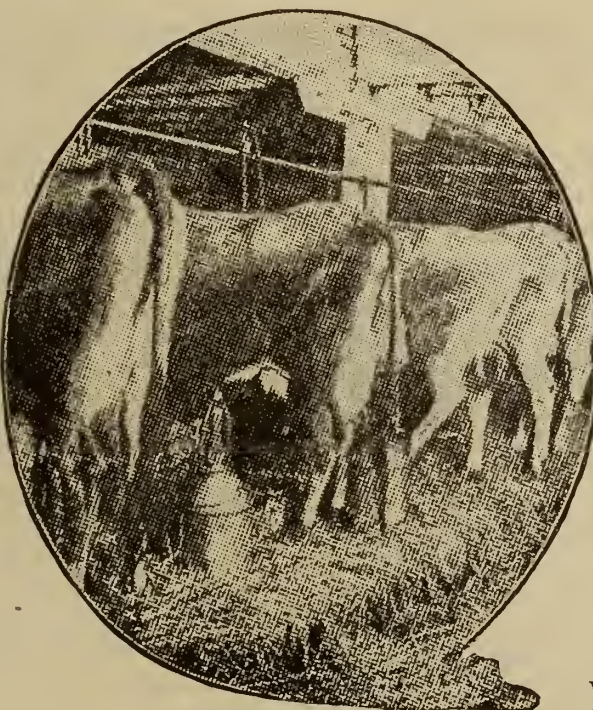

### The Premier Cream Separator

Abounds in convincing selling features. A remarkably close skimmer. All running parts enclosed. High skim milk delivery point permits large can and less changing of pails; aluminum discs can't rust; oiling direct to bearings, all revolving parts running in oil. A simple, easy-to-run, easy-to-clean machine that never fails to sell well.

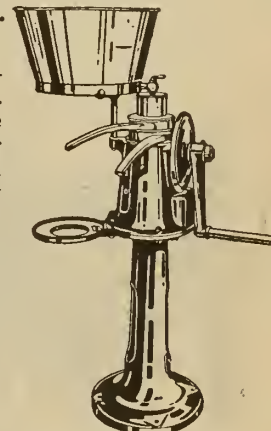

### Avery Tractor

A most satisfactory tractor in actual use because parts are so easily accessible and easily kept in order or renewed. All sizes from 8-16 H.P. to 40-80 H.P. have standardized design. A size tractor for every farm.

### Lister Engine

2, 3, 5, 7 and 9 h. p.—Standard hopper cooled, throttle governed, automatic lubrication, high tension magneto. Simple, easy to operate, economical—true British quality throughout.

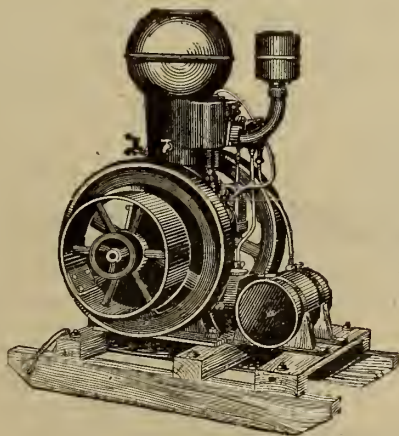

### The Lister Milker

Here is the milker of milkers on which you can stake your reputation. Has made good for years. Lister quality means long service. A system of regular inspection is maintained by company. One of the greatest sellers in the farm machinery business—a sure winner for YOU.

### Lister Grinders

Will grind as fine and do more work than any other. Great capacity, easy running, never clogs. Handles all feeds with equal success.

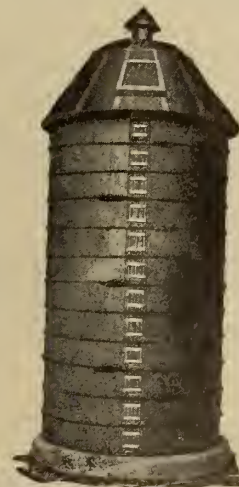

### Lister Silo

A permanent, strongly built silo that will give years of dependable service. Made of choice, well seasoned lumber specially treated with preservative. Well designed and an attraction to any set of farm buildings.

Write now for full particulars about Lister Lines

**R. A. LISTER & CO. (CANADA) LIMITED**

58-60 Stewart Street, TORONTO

Also at Wall Street, WINNIPEG

WRITE FOR AGENCY PROPOSITION



# John Deere Implements are easy to sell

—They have many exclusive features—and they are sold through John Deere dealers only.

The John Deere dealer has something different to tell farmers about implements. Farmers are easily interested in the exclusive features of John Deere implements—and easily convinced. This, too, is of prime importance to you, the dealer. John Deere Implements are sold through John Deere dealers only. There is no way around it. And the sales policy is decidedly liberal in other ways—all of which makes it advisable to push the sale of John Deere implements. It is a merchandising plan that goes farthest in helping you to build a substantial business foundation.

Here are two items that are of interest to farmers right now.



**John Deere Stiff Tooth Cultivator**  
For Summer Fallow

The John Deere Stiff Tooth Cultivator does better work with less draft. Show farmers why this is so. Show that it makes a better mulch—that all shovels lift level—that they are wide and provide a substantial overlap. Farmers are interested in the fact that every bit of ground is pulverized—no weeds missed or pushed aside. Show your customer the extra strong angles and angle braces. It is easy to prove that the John Deere Stiff Tooth Cultivator is easily adjusted and operated, and that it lasts longer and gives better service.

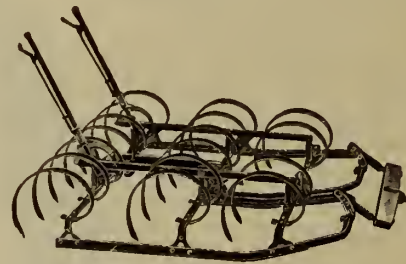

**John Deere Syracuse Spring Tooth Harrow and Quack Grass Destroyer**

Farmers everywhere enthuse over this harrow that does a better job of pulverizing and smoothing the soil than other harrows. It digs up the under soil and brings it to the surface with greater ease and certainty. The framework is constructed so that there is no choking or loading. It has a small opening in front which widens toward the rear. Teeth are spaced so that all trash works toward the centre and out through the opening. The teeth are instantly adjusted.

## Arrange NOW to Sell these Quality Implements:

John Deere Low-Down Manure Spreader  
John Deere-Van Brunt Grain Drill  
John Deere-Van Brunt Fertilizer Drill  
John Deere-Dain System Left-Hand Side-Delivery Rake  
John Deere-Dain Hay Loader  
John Deere One-Horse Steel Cultivators

John Deere Syracuse Spring-Tooth Harrow  
John Deere-Van Brunt Lime and Fertilizer Sower  
Hoover Potato Diggers  
Hoover Potato Planters  
Hoover Potato Cutters

John Deere Scufflers  
John Deere Corn Planter  
John Deere Cultivator  
John Deere Beet Tools  
John Deere Syracuse Plows—(Riding, tractor, walking)

*The John Deere Sales Policy is most liberal. Write for information if you are not now a John Deere Dealer. Get the utmost out of your ability.*

**John Deere Manufacturing Co., Limited, Welland, Ontario**



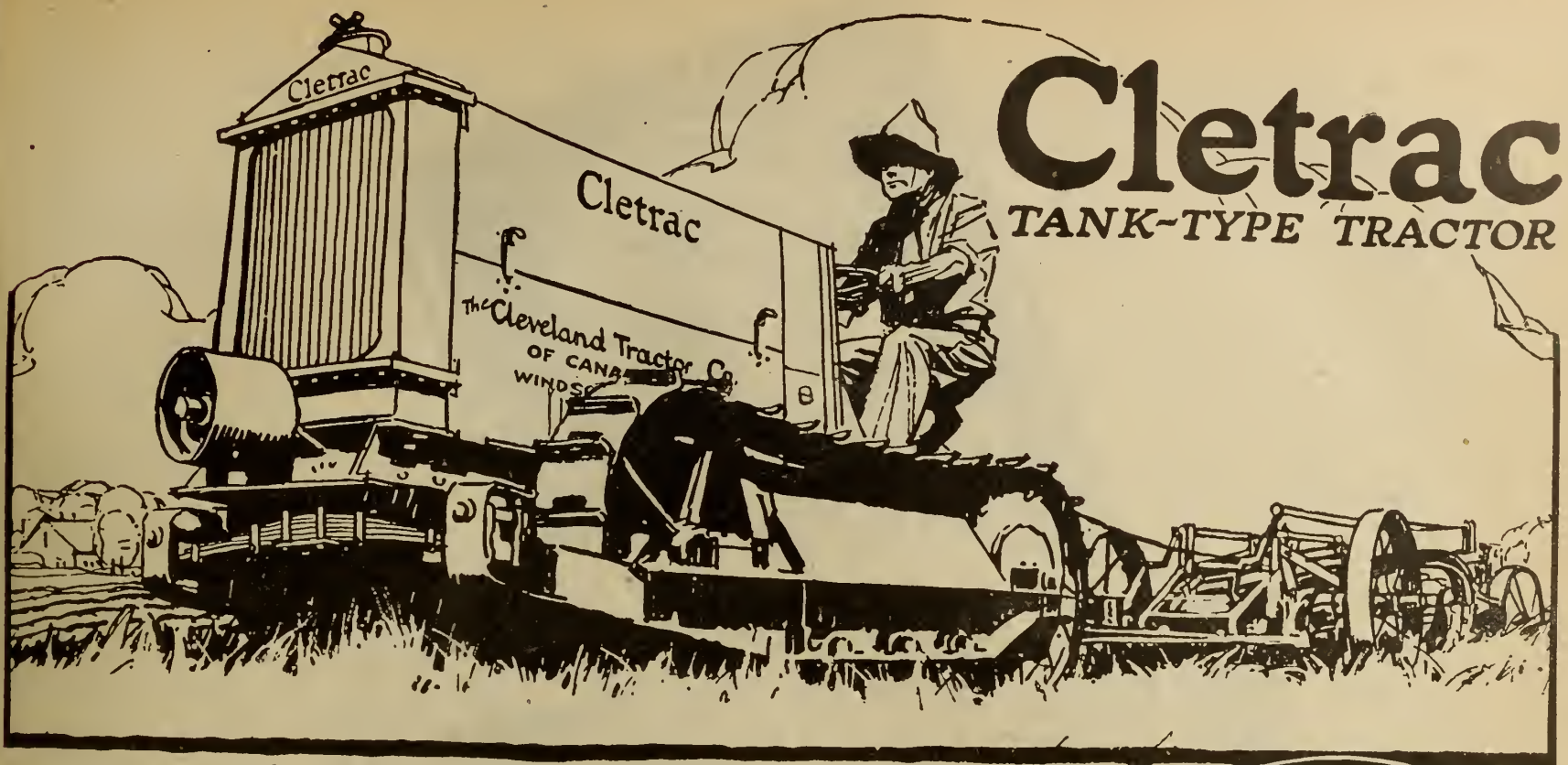

Added Power — No Increase in Weight  
Wider Tracks — Lighter Tread — Stronger Ground Grip

*More kinds  
of Work  
More days in  
the year*

## Are You Ready for the Rush?

Because of the hard Winter and heavy snowfall, it is going to require an unusual lot of rush work to get the seed in the ground early enough this season. Spring is almost here. Farmers everywhere are, right now, studying up ways to get their crops in early.

Most farmers already know the Cletrac favorably and our advertising is winning new Cletrac converts every day. Our big March advertisements in the leading farm papers told about the **improved** Cletrac with wider tracks, the exclusive steering device and the new water air cleaner.

The demand for Cletracs is growing fast. A lot of Cletracs will be bought in your vicinity within the next few weeks. You can easily get **your** share of the orders and your share of Cletrac profits if you are ready to do your part.

You can't get back of the Cletrac too strongly. It is the tractor that can be **first in the field**. Talk Cletrac's all-round handiness—that it can do more kinds of work more days in the year than any other tractor. Every farm, big or small, soft or sandy, wet or dry, needs a Cletrac or more than one. Selling Cletracs is easy work this Spring and you are going to get big pay for every bit of time and effort put into Cletrac sales.

You can't afford to delay. Get ready for the rush. Get a Cletrac agency. Get four or five Cletracs on your floor and have others coming to you in order. Call on every man in your locality who needs a Cletrac and talk Cletrac's advantages to him before May 15th.

If you are not a Cletrac dealer now, write for our dealer offer. We have a liberal proposition for you.

# The Cleveland Tractor Company of Canada Limited

Head Office:  
WINDSOR, ONT.

Western Sales Office:  
REGINA, SASK.





## Make This Book Your Buying Guide

It will keep you in touch with every phase of mechanical equipment, no matter what your business may be. It will keep before you the advantages of concentrating your buying in one place, where everything mechanical needed for the factory, power house, machine shop, garage or farm is obtainable.

It should be permanently on the desk of every purchasing agent—every buyer of mechanical goods.

*Write to-day for your copy of*

### General Catalogue No. 20

the most complete compilation of information for the Canadian buyer of mechanical goods, departmentalized, conveniently thumb-indexed, and cloth-bound.

## The Canadian Fairbanks-Morse Co., Limited

St. John    Quebec    Montreal    Ottawa    Toronto    Hamilton    Windsor  
Winnipeg    Saskatoon    Regina    Calgary    Vancouver    Victoria

---

*Scales   Valves   Steam Goods   Oil Engines   Pumps   Electrical Machinery   Machine Tools  
Transmission, Railway and Contractors' Equipment   Automotive Equipment*



# CANADIAN MOTOR, TRACTOR AND IMPLEMENT TRADE JOURNAL

Volume 2

TORONTO, APRIL 5, 1920

Number 4

## Helping the Accessory Dealer Win Out

By F. H. SWEET

**T**HERE are only two really important problems which confront the retail merchant, and these are buying and selling. The success of any business depends very largely upon these two phases, and each is of great importance. It is a question just which is of the most importance at the present time. Some view buying as the most important factor in successful merchandizing, arguing that the stock which goes into the store is the food upon which the business strength is built, and that the methods of selling, important as they are, only go to dispose of that which is purchased. This is true.

Buying is the very first requisite of a successful business, and no merchant can hope to overcome the handicap of poor buying sufficiently to operate his business under the present conditions with even moderate success.

It is, therefore, important that the merchant be a good buyer. Without belittling the importance of good buying, I sometimes think that buying is usually over-stressed under the delusion created by that old adage that "goods well bought are half sold." But what of the other half of the sales operation that remains?? Goods half sold are no better than goods unsold if sale is not completed.

The buying of the goods is merely the first half of the transaction, and, important as it is, it does not complete the transaction. The half that remains, that of actually selling the goods, is by far the most important part of the transaction. And while there is much truth in that old maxim that "goods well bought are half sold," it should go without saying that "goods all sold were well bought." The mere fact that the goods were well bought does not sell them, although goods well bought are much easier sold.

Almost any merchant who has provided his business with a proper system of buying records can buy goods if he has the market or outlet for them, but not so with the selling end of the business. Selling covers a multitude of activities, and many a good buyer has gone down to ruin because he could not cover the selling end of the game.

The main problem before the accessory dealer during these days of keen competition is to sell, not merely to have on hand those articles for which his customers may call, but he must put up a strenuous fight for business, not because business does not exist, but in order that he may get his full share of the business.

**T**HERE never was a field which offered such opportunities for building up a large and successful business as does the accessory trade. It is not that business does not exist that the accessory dealer must make a strenuous fight for business, but because of the increasing competition that is making it so important for him to put up a vigorous fight for trade. Almost every hardware store in the land is installing an accessory department, and in some of these stores this department is becoming the leading one of the business.

Mail order houses are going after the accessory trade with a vim and energy that should make the

accessory dealer sit up and take notice. Only recently two of the largest mail order houses in the country sent out several million copies of catalogues listing some 50 pages of accessories. Another mail order house sent out a catalogue with more than 60 pages of accessories. Only the wide awake accessory dealer is going to be able to meet this competition.

The local accessory dealer has many advantages over the mail order house. He is in close touch with his prospective customers all the time. By watching his operating expense he should keep his cost of doing business down to such a point where he can successfully meet the mail order house prices. It is not necessary for the local dealer to set his prices on an equality with the mail order house, as he should take into consideration the transportation charges

community, it is best to ignore them altogether especially in general advertising.

The best plan is to try to line up the names and addresses of the car owners in the community who are patronizing the mail order houses, and send them a personal letter touching upon the various advantages of buying at home, and asking them for the opportunity of figuring on their next order for accessories. Never "knock" the mail order house in your advertising or in your sales talk. When you "knock" you get people thinking that there may be something in buying from the mail order house after all, or you would not be squealing. It is enough to realize that the mail order house is coming into your territory, that it is one of your real competitors and that you must go after the business with renewed energy.

Winning trade is "getting people into your store." This is a big job. You should consider every possible means of attracting the attention of the public and arousing their interest in the particular store exploited. The very first thing that should receive your consideration is the stock of merchandise. If you are to meet competition successfully you must have in stock every item of merchandise for which there is a demand.

Such items as tires, tubes, plugs, jacks, tire tools, patches, tape, lace-on boots, etc., are standard articles of stock and will be found in any accessory store or any store catering to the auto trade. But in every locality there is a demand for certain articles peculiar to that particular locality, and it is up to the individual dealer to carry these in stock. The best way to determine what line of accessories is the most likely to be in demand is to know the makes of automobiles that are the most popular in your locality, and then stock a line of accessories especially adapted for these machines. For instance, an accessory dealer located in a town of 4,500 where the most popular machines sold are the Buick, Dodge, Overland, Ford and Essex, and possibly an occasional Hudson, Packard and Cadillac, would want a stock of accessories for these lines of cars, holding the lines especially adapted to the three last named down to a limited supply. He would not want to stock an extensive line of accessories for Stutz, Premiers, Elcars, Empires, Bush and other cars which had a very limited distribution in his community. The

city dealer may handle a much greater variety of accessories because of the larger number of various makes of autos sold there.

**T**HE following is a memorandum of Preferential Tariff Allowed Canadian Goods within the British Empire. March 29, 1920.

	Regular	Preference
United Kingdom ... Foreign	33 1-3%	Canadian 22%
South Africa . . . . . Foreign	40 %	Canadian 17%
New Zealand . . . . . Foreign	40 %	Canadian 10%

Australia.—On the 27th of February the Parliament of Australia was called together and the impression exists that they will revise their tariff towards Canada. Nothing as yet has been done.

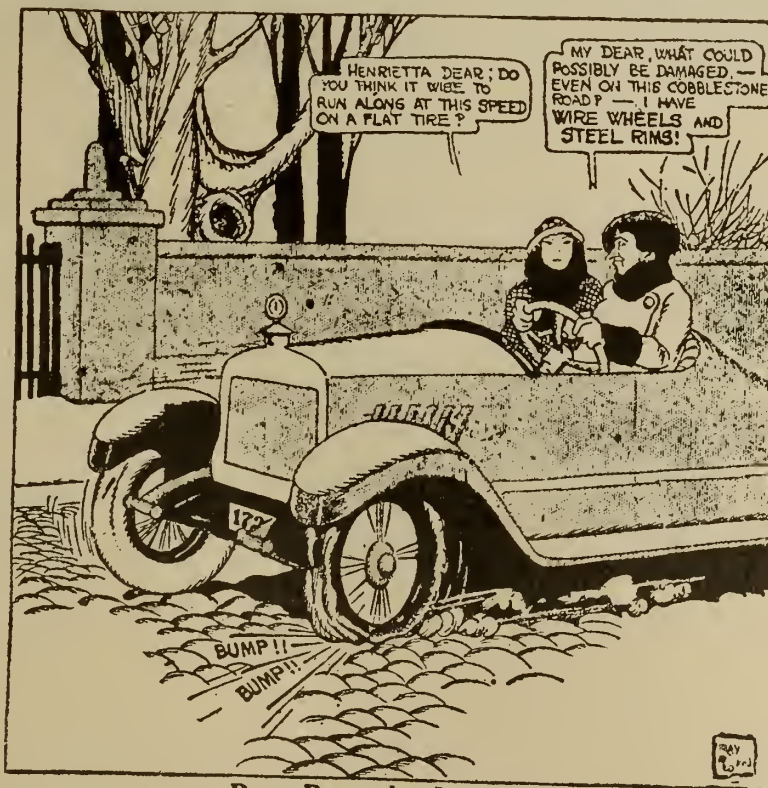

Boy, Page the Mechanic

—Philadelphia "Ledger."

and the interest that is lost on money paid in advance. Another advantage the local dealer has over the mail order house, and one that the dealer may use to his benefit, is the delay the customer experiences very often in receiving goods from mail order houses. The dealer who finds that a great deal of the accessory business of his community is going to the mail order house cannot do better than to emphasize this point strongly in his advertising.

Another point the local dealer should emphasize is the advantage of examining merchandise previous to purchasing, something which is impossible in the mail order business. There are plenty of other arguments that the local dealer might use, but, unless the mail order houses are making great inroads in the



# THE TRACTOR IN THE WEST

**I**N THIS period of transition from war to peace perhaps the phrase most often heard is "greater production," greater production along all lines, but more especially of the great essential, food. Prices have attained new high levels, because for a long time so large a portion of the world's population were consumers only. Prices will only attain lower levels, and the cost of living decline, as a surplus of food stuffs is created.

Canada's duty to the world at large, and to herself as a nation, is to bend every ounce of energy towards production, and in analyzing the situation the only solution is, farm better and farm more. The tractor will play an important part in this period of greater development. Without the tractor it would indeed be a stupendous task.

From research made by various parties a conservative estimate of the number of tractors in actual operation on Western Canadian farms is twenty-five thousand, nine thousand of which were purchased in 1919, and indications are that at least ten thousand more will be purchased during 1920. You may ask—there room? It has been estimated that the acreage of unoccupied lands in the three Western Prairie Provinces exceeds fifty million acres. It is inhabited at present by only a quarter of a million farmers.

The modern farm tractor is the farmers' greatest friend, and is doing more than any one can measure at this time to increase production, and permit the rapid development of fertile tracts so long awaiting cultivation.

Much blame has been attached to the tractor heretofore which rightly could be traced to the operator. With the courses offered in mechanical engineering in our agricultural colleges, and the schools conducted by the various tractor companies themselves our boys are learning how to operate them successfully. Then, too, tractor builders are realizing the value of standardizing their product, and closer co-operation on the part of the manufacturer and the user is resulting in greater efficiency and greater satisfaction.

The writer had occasion to be present at the five large Western fairs last year, and met hundreds of farmers daily for a period of five weeks. You will agree with me that during that length of time, interviewing farmers from every part of the three Prairie Provinces, one would hear every side of the power farming question, and I did. Ever since I have been more convinced than ever of the need of tractors, and the field there is for tractor sales. The farmers here in the West no longer need to be convinced of the convenience, economy and great utility of the tractor. Experience this last few years has proven beyond question that more work can be done

By W. A. PRUGH

with greater ease by power farming than by former methods.

**I**N WESTERN CANADA the growing season is very short. It is necessary to work hard, fast and long to prepare the seed bed in proper time, and work done on time, in its proper season, always results in larger yields. The tractor is the rapid fire gun that will win the battle, and bring the West to a higher state of cultivation in a short time.

There are many types and sizes on the market. The tendency more recently has been away from the large cumbersome type to the smaller tractor more suited to general purpose work. In many cases the farmer has over-estimated the capacity of his tractor, and expected too much from his smaller machine,

Too much importance cannot be given to quality and service. Manufacturers should realize more than ever that the tractor is here to stay, and that to get repeat orders they must put quality into their goods.

**T**HERE are three parties interested in the Western tractor situation at the present time—The MANUFACTURER, the DEALER and the FARMER. The manufacturer wants to sell his goods, and must make an article that will meet the demand. The farmer wants and needs tractors, and the dealer is the medium through which these two are each supplied with their want. The success of the industry depends as much on the Dealer selling the farmer what he really needs as it does on the manufacturer in making a good article. The influx of new settlers, the re-establishment of our soldiers, and the great movement "back to the land" are all going to have their effect on the tractor business.

The spring season is here. Already we are feeling the effects of the warm sunshine. The "chug, chug" and "purr" of the tractor is heard throughout the land. The warm earth is being turned up to grow mellow in the sun and awaits the seed. Vast acres need only the modern tractor and the plow to turn them into fertile fields.

The call of Nature is abroad. Are we alive to our possibilities? The cry is going out daily for increased production, and lower cost of food stuffs. The West is the great Bread Basket of the world. What it needs is more tractors and better tractors. Take away the tractors now in use, or prevent the farmer from buying more, and what would happen to our production and food costs?

The land, the tractor and the grain can be likened to the clover, the bee and the

honey. The tractor is as truly essential to-day in the production of grain as is the bee to the production of honey. It is a most important link in the chain of our modern farm life. We cannot do without it here in the west.

*Tractor Manufacturers, Tractor Dealers and Farmers, let us each analyze the other's view point, and strive to realize that we all play a most essential part in bringing our vast undeveloped areas to a higher state of cultivation and production.*

**A**CCORDING to a Winnipeg report implement dealers of the West fear a serious shortage of farm machinery and tillage implements this spring. There is a big demand now and by the time spring opens up it is likely to be abnormally large. Manufacturers in Canada and the United States complain of lack of materials and difficulty of obtaining delivery. As a result goods which have been ordered months ago have not been delivered yet.



A typical Western scene—seed bed was prepared by tractor.

and as a result has condemned the use of tractors, but the reasonable man who gave the same care to his tractor as he would give to a pedigreed horse has had results. We all know that there are some tractors on the market poorly designed, and built far too cheaply—built to sell and not to serve—but tractors as a whole should not be black-balled because of them. The well built medium sized tractor is here to stay. *The Western farmer needs and is demanding Simplicity, Durability and Economy in a tractor, and SERVICE FROM HIS DEALER.* He is not buying with his eyes shut. The majority are purchasing only after having conducted a thorough investigation into the various makes.

There is a limited use for the large outfit, particularly for breaking large tracts.

There is a field for small tractors where farms are smaller and work is not done so extensively.

But the demand in the West seems to be for the well built medium sized machine.



The tractor will solve the "more production" problem.



First prize tractor plowing at Portage la Prairie.



# Good Profit in Handling Lightning Rods

**T**HE Provincial Fire Marshal is having an act introduced in the Ontario Legislature to make it compulsory to protect against lightning, the following classes of buildings:

(a) All farm buildings, hereafter erected, costing \$2,000 or more, including groups (within 25 feet of each other), and additions to existing structures.

(b) All buildings on farms or in rural districts containing food stuffs or other farm produce to the value of \$2000 or more.

(c) All grain elevators, flour, cereal and grist-mills, and sugar refineries.

(d) All spires, towers, chimneys and buildings sixty feet in height or over.

The act also has far reaching provisions for regulating the manufacture, sale and installation of lightning rods, the enforcement of the act to be under the direction of the Fire Marshal's office.

To those not well informed on the subject, this act may seem drastic; but the Fire Marshal has good ground for advocating such a measure. He found last year that there were 1,045 lightning fires in Ontario, with a nominal loss of \$490,557, or practically half a million dollars. The real loss is much greater, and may reach twice that amount. They were mostly farm buildings, although the other classes mentioned came in for their share. And amongst the 1,045, there was not a single case of a properly rodded building being fired, although in country districts about one-third of all buildings, taking it on the average, are protected against lightning. There were a few cases of improperly rodded buildings that were fired. In 1918 there were 1,166 fires, again for about half a million dollars of loss, and not a single properly rodded building amongst them, and only one improperly rodded one.

**W**HETHER the proposed act becomes law or not, it has one clear meaning for the manufacturer and vendor of lightning rods, viz.: It gives the business a new status; it proclaims to one and all that there is no inherent reason why there should be a stigma attached to this business. Yet such has been the case for many years, and why? because those engaged in it in early years were for the most part ignorant of proper methods; and the people for whom rods were being installed hadn't the slightest notion of how it should be done; the requisites of a good rod were not understood, consequently some very inferior rods were manufactured, e.g., the iron rods, and especially the twisted iron centred rod—many buildings protected with these have to be rodded again; and lastly because some unscrupulous "lightning rod" men, perpetrated numerous frauds of one kind and another. All these factors, and perhaps others, gave the business a bad reputation from which it has fortunately been recovering during recent years. The proposed act will help standardize the business more than anything else that has happened in its history. It will mean that every agent who installs rods must be:

1. A reliable man—because no one can obtain a license until he presents a certificate of character from the mayor or reeve of the municipality of which he is a resident.

2. A trained man—for if he puts up a poor job his license and the license of the firm he represents may be cancelled by the Fire Marshal.

At the present time there are some lightning rod firms which make no pretence at training their agents—they sell the goods to the agents, accompanied by some printed instructions, if the agents do the work

By **W. H. DAY, B. A.**  
Formerly Professor at O.A.C.

well, all right, if not, again all right, so far as the firm is concerned. I am glad to say there are several firms which do train their men; new dealers receiving special attention.

And when I say the Lightning Rod Act will standardize the business, I mean not only that the rods themselves will have to be up to the standard, but also that the agents will have to be reliable men, and that all manufacturers will have to adopt stringent measures in training and supervision so that every installation will be first class in every particular.

That's what the Lightning Rod Act should do for the lightning rod business in Ontario. And I predict the heaven will spread to other provinces. Already I know another province where some of the members of the legislature are thinking seriously of introducing the measure in their Local House.

**I**MPLEMENT dealers, and dealers in other lines as well, will not be slow to appreciate the splendid opportunities the lightning rod business offers under these new and encouraging conditions. Hundreds of dealers are finding it a very profitable side-line, and many more are devot-

because when they become rusted on the surface their capacity for carrying current is greatly reduced.

It is to be hoped the Lightning Rod Act will pass the legislature. Many farmers in years gone by have asked me to advocate such a measure. Four years ago I went so far as to outline the provisions necessary in an act, though without any compulsory clause, and forwarded it to the department, but it was pigeon-holed. The present proposal of the Fire Marshal's should be a good measure for the manufacturer who wants to give the best service in lightning protection, also for the dealer who wants a clean, legitimate line with a reasonable profit; and above all for the purchaser who knows nothing about the science of lightning protection, and needs some guarantee that when his buildings are rodded he has the perfect protection that only a good job can give.

## SASKATCHEWAN BRANCH OF THE R. M. A. FORMS AUTOMOBILE SECTION

**T**HE publicity bureau of the Saskatchewan branch of the R. M. A. has sent out the following circular:

The work of the Saskatchewan Branch of the R. M. A. has now been very considerably extended by the addition of an implement section at the Provincial Office, Saskatoon. This section, which has been formed specially to look after the interests of the implement and automobile dealers in the province, is in charge of Harry Pizzev, who has had wide experience in the implement trade and is also an experienced accountant.

In the course of his work he will endeavor to secure the necessary data in order to compile a comparative statement showing how the margins of profits allowed to the implement dealer have decreased during the past five years. While the price to the consumer has been gradually increasing the margin of profit allowed to the dealer has not increased in proportion to this increased price and the continually increasing expense of carrying on business. In addition to this, Mr. Pizzev will, in the course of his travels, give any assistance that may be required to the dealers with whom he comes into contact.

Mr. Pizzev will eventually devote more of his time to actual organization work with a view to increasing the membership of the Association amongst the implement and automobile dealers of the province to as near 100 per cent. of those engaged in these lines of business as possible. If we are to reach this goal it will be necessary for the Association to have the moral and financial assistance of the whole of the implement dealers throughout the province.

We would be glad if the implement dealers of the province would take advantage of this new Department in our work by drawing our attention to any matters of interest to the implement and automobile trade which they consider should be taken up and dealt with.

It is hoped that other western provinces will be encouraged to take up work of this nature and to establish an organization similar to the one in Saskatchewan, in order that united action can be taken where necessary in the interests of the implement and automobile trade.



Sheep Building, Central Experimental Farm, Ottawa, protected with cable and fixtures.

ing their entire time to it during the summer months. In the past the high class companies, those who have been giving training from the factory right down to each individual dealer, as outlined above, have had to contend with considerable cheap competition on the part of those other firms who are giving no training and no service, and some of whose rodding will have to be re-installed before it will pass the inspection of the Fire Marshal's office. When all firms have to give similar service the cheap competition should be largely eliminated, though even then it is quite conceivable that some firms may be able to give much the better training and service. The purchaser above all others, will appreciate the provisions of the new act, for when he has his buildings protected he will be sure that it is done right, and done once for all.

Dealers will appreciate a word or two about types of rod. They divide themselves into two broad classes, viz.: round and flat. As to material, copper is rapidly displacing all other metals for lightning rod purposes. Some iron rods are still sold, especially in Quebec, but they are inferior, first, because they are less durable, frequently rusting off at the ground, and secondly,



# A Contractor—But Not a Chronic One

## He Built Houses—Now a Successful Implement Dealer

**“C**ANVASSING THOROUGHLY;

“Studying prospects closely;

“And real, hard, honest-to-goodness work:

“These are the fundamental points which have helped me to whatever success I have achieved in selling implements,” said T. S. Haney, implement dealer of Fenwick, Ontario, to an M. T. I. representative recently when discussing with him some of the reasons for his success.

“There are a great many other reasons, of course,” he continued “but these are the fundamental or primary.”

It is always interesting to learn of a man branching out into new lines of endeavor, but when that man is forty-five years of age, and has been an undoubted success in a particular line, we naturally “sit up and take notice” when he suddenly switches around and adopts a new trade or profession.

Courage is required for such a trick and courage of a high order.

Mr. Haney is such a man and he possesses both courage and good common sense. When he started out in life he chose the trade of carpentry and at the age of twenty-two was working as a fully qualified artizan.

A few years later he branched out for himself as a contractor—a builder of houses—and pursued this line until two years ago when he broke into the implement field. At first, it must be admitted, he tackled the new line in a rather half-hearted manner—more in the nature of an experiment than a serious attempt to establish a real business.

**U**P TO the commencement of the great war and for two years afterwards the building business had been good but when the cry went out for men and more men, and labor and material became difficult to procure Mr. Haney was persuaded to enter the new field.

It happened this way.

About two years ago while putting up machinery in a canning factory for one of the largest power machinery concerns in Canada he was approached by a representative of the company and invited to become its agent in his district for farm engines. He pooh-poohed the proposal at first but the representative was persistent and kept at him until he finally consented to take the agency—as a side line. But let Mr. Haney tell his own story.

“When I took the agency for farm engines I had no intention of giving up my contracting business. It struck me that selling engines would make a good side line until the bulding trade picked up and as I had some time on my hands I could use it profitably canvassing the farmers.

“After three months I was surprised at the number of sales I had made and encouraged by my success I decided to give more time to the new business.

“I took on the agency for a well-known line of implements and commenced in real earnest to do business with the farmer. In my first year I made a clear profit of \$800. I now decided to go into the implement buisness seriously, and commenced to add to my line. I took on a separator and numerous other lines until to-day I handle practically everything required in power-farming.

“In the contracting business I was fortunate in earning a reputation for honest dealing and for taking pains to please. This has stood me in good stead in my new work.

“I am a firm believer in honest dealing and have tried to build my business strictly on that principle.

“I study my customers and their needs; study the conditions in which they are working and try to sell them something for which they have a real use.

“With my policy of canvassing I have a fine opportunity to see the farmer and to talk with him right on his own door step. I take an interest in his problems and talk them over with him. In this way I get first hand information about my prospects and know pretty well just where a separator, milking machine, spreader, plow or engine is required.

**“L**AST year I succeeded in doing a \$17,000 business and hope to do considerably better this year.

Most of this business was done for cash. The farmer in my territory almost invariably prefer to do business on a cash basis, and I do all I can to

ness will put the dealer on the right side of the fence.

**“M**Y territory is largely a fruit growing district and covers an area of about twenty-five square miles. It is rather a large territory for one man to cover and give the proper kind of service. However, I keep my car pretty busy and so far have been able to handle the work alone. I expect though to hire some help as I have a feeling especially since I built my new warehouse and work-room—that the business is growing too large for one man to handle. I could keep a man busy on service work alone.

“Prompt attention to service calls I consider very essential and ability in the dealer to do repairs practically compulsory.

“I don't like dealing in second hand goods. This is not a junk shop nor am I running an old iron business. The only condition under which I will accept a second hand machine is if I know for certain where I can dispose of it.”

Mr. Haney's business grew so rapidly that last summer he decided to build a store and work-room.

The new building, now practically complete, is up-to-date in every way, and, the M.T.I. representative avers is a somewhat unique one in the implement field. It was designed and built by Mr. Haney himself.

The material used in the construction is wood and concrete. The building is 25 x 55 and two storeys high. The front is completely occupied by two large plateglass windows. The finishings inside are especially good and with little streak of imagination would make a suitable book store.

Shelves are built in all around the store where repair parts and accessories will be kept. The office—Oh, yes, there is a real office—with desk, telephone, stove and everything that a good office should have and it presents a fine business appearance.

**W**HEN asked if he didn't think the store was too “high-falutin” for an implement business Mr. Haney said:

“I consider a good appearance is a great asset to any business and I am going to do my best to make my store the cleanest and most striking in town.”

The second storey is connected with the ground floor by an elevator and is being fitted up as a repair department. Work-benches with all necessary repair requisites are conveniently arranged around the walls.

A special feature of the equipment is a small power plant to provide power for the machinery in the work shop and for demonstrating lighting systems. Mr. Haney has the agency for a 9 k.w. automotive generator and in order to sell this properly he has arranged a scheme of demonstrations, to illustrate the value of a lighting and small electric power system on the farm.

By distributing great quantities of literature around his territory, advertising in the press and by a thorough and persistent canvas Mr. Haney expects to do a record business in 1920.

### NO GARAGES UNDER HOUSES

**A**LDERMAN SINGER at the Civic Works Committee recently moved that a by-law be passed prohibiting the construction of private garages under dwellings. The motion was carried.



This picture shows Mr. Haney's splendid implement store at Fenwick, Ont.

encourage them. This eliminates the trouble of extensive book-keeping and besides both parties are benefited by a cash sale. Of course where I am convinced a man is financially sound I will accept his note, but I always point out to him the advantage of paying cash down.

“I don't like dickering over a sale, especially if my prospect is stubborn over a few dollars. While I never cut prices, in the strict sense of the term, I will come and go a little to suit the peculiarities of the case. Each customer has to be studied and suited. No two men are alike except in this that we all have our peculiar point of view and if we happen to be a purchaser we claim the right to be satisfied in our purchases.

“It is well to keep that in mind when making a deal. It may mean the difference between a satisfied and dissatisfied customer. Every dealer knows a disgruntled customer is a dangerous man to have in his territory. The saying, “the customer is always right” is a pretty good one for us dealers to use as a motto. Not that the customer is really always right but some such motto or principle of doing busi-



How the Garage Man Will Benefit by

# BETTER BUSINESS METHODS

By CECIL DIXON

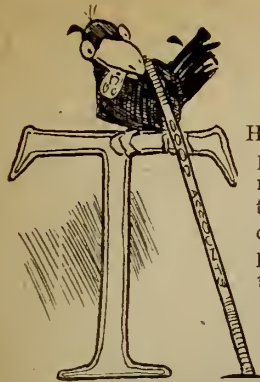

HE constantly growing appreciation of the public in motor cars, trucks and tractors as useful, economical machines and sources of health, pleasure and profit, has led the majority of dealers and garage men to take a pride in the business and become enthusiastic about the future of it, and they

are—or should be—interested in:

How to get the greatest possible benefit from this Automobile Business and how to keep that prosperity on the increase. To point the way to this goal is the object of this article.

Every season large numbers of automobile repairmen start in the garage business but, sad to relate, quite a portion never make "good," simply because they fail to learn and practise ordinary business rules. And the worst of it is, that these fellows who fail to survive, almost always "rock the boat" of the better garage men, proving that to have a solid, substantial industry EACH dealer or garageman must be a good business man.

One of the very first essentials for every garage man and automotive dealer who is going to make a lasting success is to give strict and careful attention to keeping a record of his business—the handling of money, time and materials.

Any one making a canvas of ALL the garage men in many towns will be amazed at the number who keep no regular record of their transactions.

The garage man who would become successful must first have the means of knowing what he has, what he owes, how much he must add to his first cost in order to cover his rent, heat, light, taxes and other running expenses, as well as to make a reasonable profit on his investment, and time expended. He should know how much money he can afford to put into advertising. He should know how each month's sales or business compares with each other month and with the corresponding month last year. He should know which goods he can handle at a profit, and which are, perhaps, not worth handling at all. He should know whether, after investing his money and his time and energy in this business if the net return is worth while.

If it isn't—let him go out of business—there isn't room in it for the man who cannot make it pay. A proper system of accounts will turn a spotlight on your business, will permit you to examine it carefully and critically, and enable you to see your mistakes and correct them and give you an exact means of measuring your success.

Competition is keen and the man who knows his own cost—and by cost is meant not only the cost of that merchandise, but the cost of handling it, holding it, advertising it, selling it and collecting it—that man has a real basis for figuring his own selling prices and is not misled by a price slashing competitor into cutting his own throat. Know your own business and you will have little fear from your competitors.

The word "bookkeeping" has become a bugbear to many a good man. It need not be if you understand the difference between "keeping" books and knowing your business through a system that gives you a sound basis for action instead of doubt and guess work.

For the garage man whose business is as yet too small to

hire a young lady or young man on a permanent basis, it is recommended that he get some really good bookkeeper or auditor—in the town—to open up a set of records and if the daily transactions are few in number he can easily arrange to engage some young lady to enter up these transactions by spending an hour or so in the afternoon or evening each day.

Above all else do a cash business.

There is now no reason why you cannot get spot cash for all your service and repair bills at the time the work is completed, and put all sales of accessories or other goods on a cash basis.



Feed your business on cash sales.

Why some garage men will work all day and sometimes part of the night and then allow the car owner to drive away without paying for the labor, parts, or accessories is beyond understanding. Nearly all of us know of cases where the failure of garage men to get paid on completion of work has resulted in bad debts, unpleasant collection interviews and eventually put them out of business.

Therefore, above all things, do a spot cash business. Set the amount of business you wish to do for each and every day, week, month and year—put it high, as no man can do more than he expects to, and go to it hard. Not every man can make a fortune, but almost every garage man can make a good living if the garage is run on a proper business basis.

Therefore, above all things, do a spot cash business.

Set the amount of business you wish to do for each and every day, week, month and year—put it high, as no man can do more than he expects to, and go to it hard. Not every man can make a fortune, but almost every garage man can make a good living if the garage is run on a proper business basis.

TO keep step with the march of progress, to maintain a garage on a plane with the other merchants and dealers and to secure the greatest amount of service or repair work, accessories, etc., that your place of business is capable of handling, the garage man must ADVERTISE.

To make money one must spend money.

Advertising, carefully planned and placed, is an investment that brings big returns to the man who uses it knowing its main purpose—to create new business, to win customers that would not have been won without it. Probably the local newspaper is one of the first mediums to come to mind. Except in large cities this is the logical medium, for it brings your name and your business before a large field of prospects, and it gives you standing in your community. It can be adjusted to weather conditions or seasons; running large when the season is about to commence and smaller when the motor cars and trucks in the country are stored for the winter. Few garage men need to be told the value of newspaper advertising, but many can be shown ways in which to increase the effectiveness of their newspaper advertising.

Circular letters, blotters, souvenirs or yearly calendars carry advertising effectively if sent to a selected list of motor car owners, or prospective customers for your repair work.

These circular letters are more direct than the newspaper, as they go straight to the owner of the motor car, truck or tractor and carry YOUR message and no other. To get all the business you can handle, extra sales efforts are necessary in addition to the regular practices of the ordinary garage man. Therefore, realize the need of doing those extra things that will mark you as a leader instead of one of the rank and file. If necessary, when business is dull, go out personally and canvas your prospects, and you may be surprised at the amount of business you will get at a time of the year when you most need it.

In February issue of M. T. I., there is a special article on the need and advantage of co-operating with, or associating with the other garage men and motor car dealers in your community.

Do not get so close to your business that you cannot see, or become familiar with, the other fellow's problems.

In the March issue of M. T. I., there is an article on store arrangement and window display.

Do not overlook the need of care in arranging your garage or repair shop and particularly your windows, because for every one person who sees the inside of your place of business, there are hundreds who see your windows and judge you by them.

## IMPLEMENTS SCARCE IN SOUTH AFRICA

THE Standard Bank of South Africa states that shipments of agricultural implements to that country from America have been lessened by the adverse exchange rates.

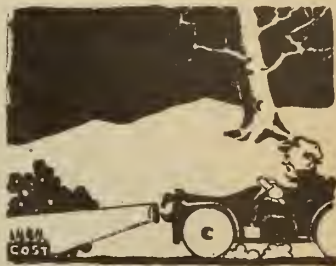

A proper system of accounts will turn a spotlight on your business.



Do some spring cleaning now.





The home of Duffus Motor Sales—note the slope at the side leading to the lower storey.

# A BUSINESS WITH A PUNCH TO IT

Peterboro has a \$50,000 Garage with 90 Windows

**B**ORN on a farm;  
 Worked there until the age of 21;  
 Sold implements successfully for ten years;  
 Entered automobile field in 1910;  
 One of the first to handle Ford model "T" cars in Ontario;  
 Elected Alderman;  
 Became Mayor after six years' service;  
 Declined nomination to the Dominion Parliament;  
 Now proprietor of a \$50,000 garage.

The foregoing is the chronology of Jos. J. Duffus, proprietor of Duffus Motor Sales, Peterboro, Ontario. There are few garages in Ontario the equal of Peterboro's "show place." It is unique in every way—in location, design, construction, finish and equipment.

When Mr. Duffus graduated from farm implements to automobiles, the motor car industry was practically in its infancy—at least in its early childhood. Just how far Peterboro had progressed in motorization can be gathered from the fact that when Mr. Duffus entered the field the only agent in the town was a plumber, and the advent of a motor car on the street was still novel enough for everybody to come out of his store, his home, or favorite saloon to gaze at the new wonder.

For the first eighteen months Mr. Duffus occupied a small garage on George street. He realized from the beginning that the automobile business was one which called for special salesmanship and efforts quite apart from those which he had hitherto employed in selling implements. Right from the beginning he adopted the policy of publicity, and more publicity, and he got this by advertising in the press, by special literature, by canvassing and demonstrations.

He gave a novel turn to his demonstrations by attending every fall fair, large or small, in the country for miles around his territory, exhibiting his cars and giving demonstrations. By following this policy day and night, week by week, and year by year, he soon built up a good business and had to seek larger quarters. He found these on Simcoe street, but after a few more years of steadily increasing business larger quarters again had to be found.

This time Mr. Duffus decided to build and the present up-to-date garage on the corner of Water and Charlotte streets is the result.

AS we stated, the new home of Duffus Motor Sales is on the corner of Water and Charlotte streets. An excellent location. It forms one corner of the

market square; the most important hotel of the town is just across the street, and at the rear of the garage, with only a road between, are the C.P.R. freight sheds. A peculiarity of the site and a special feature which has been used to advantage is the drop of fifteen feet from Water Street to the road running parallel at the rear in front of the freight sheds. While the garage is only one storey high on Water Street it is two storeys at the rear. It has thus the unique advantage of having two storeys both of which have ground entrances and exits.

The offices, showroom, accessory department, and "in and out" garage are on the top storey with entrance on Water Street; while the work room, paint shop, storage department and boiler-room are on the lower storey with entrance from the freight sheds. This arrangement is the acme of convenience and does away with the necessity of an elevator.

Mr. Duffus designed and drew the plans himself, employing an architect when these were completed to do the scaling.

The garage is 210 x 60, constructed throughout of brick and reinforced concrete and is practically immune from fire. Tapestry brick is used for the showroom and offices and a high-grade pressed brick for the other departments.

The interior finishing is particularly good, especially in the show-room. The ceilings and walls are of stucco with hard wood trimmings. The floors are 7½ inches thick, composed of 6 inches of concrete with an 1½ inch Tarraza finish—an Italian process consisting of a composition of concrete and granite chips. White marble is used for the baseboards along the walls and around the supporting pillars. Three offices run along one side of the show-room, occupied by Mr. Duffus, a book-keeper and stenographer, and the sales manager.

The accessory show cases are in this department. They are of heavy plate-glass and 35 feet long. The accessories are arranged in a skillful and interesting manner and add to the appearance of the show-room. For the convenience of patrons cloak-rooms, tables and leather upholstered chairs are provided. There is ample space for displaying eight cars and Mr. Duffus makes a point of having his show-room filled with new cars.

The entire garage is especially well lighted, ninety windows are provided for this purpose—artificial light is seldom required during the day time. All windows are ventilating and those in the show-room are 9 x 7½ feet.

**T**HE work-room on the lower storey is equipped with every modern device and is capable of handling 30 cars on a working basis. A 5 H.P. motor provides the power for the machinery which consists of lathes, drilling machines, etc. Eighteen men are employed in this department and Mr. Duffus assured the M. T. I. that they were kept busy all the year round.

There is a paint shop on this floor, 60 x 50, where 18 cars can be stored on a working basis. Three expert painters are employed who are capable of doing the finest work.

The battery department is on this floor also; it is equipped with a Tunger rectifier and there is a storing place for about 300 batteries.

There is a wash rack on both floors—each equipped to wash two cars at once—also free air pumps so that customers can be accommodated with the least possible delay and inconvenience.

The heating system is a Spencer twin boiler which burns buckwheat coal and is self feeding for twenty-four hours. This provides the heat and hot water. Alongside the boiler-room and underneath the sidewalk on Water Street there is a huge coal bin with a two car capacity.

The gasoline is stored in an underground tank with a capacity of 1,000 gallons. It is pumped from here by means of gasoline pumps on the street and on each floor.

At the rear of the garage, on the freight shed side, there is a parking space of 210 x 40 feet. As the entrance to the repair department is on this side the significance of this parking space is apparent. There are some good patches of grass lawn on every side of the garage which are carefully cultivated and tended. The touch of green brightens and enhances the splendid appearance of the building.

In the busy season Mr. Duffus employs about 35 helpers. He is fortunate in having four brothers to officiate as the heads of the various departments. Although Jos. J. is the only one financially interested in the business the other brothers make an excellent staff and working team.

All the departments are systematized and put on their own feet, each manager being responsible for his own department and that only. In this way overlapping is avoided, and a more rapid service guaranteed.

The accessory department is a very special one indeed, laid out in such a way that the maximum amount of goods can be stored in the least possible space and immediately accessible. Everything is



arranged in boxes and on shelves, grouped according to make, style and size. The boxes are ticketed, showing article, price and part number.

A tire book is kept where the date of each tire sale, and number of tire, is recorded, so that a man can't say he purchased a tire in July, 1918, when it was purchased in July 1919. This book also provides an interesting history of a tire each time a tire is brought in for repairs, the date and operation is entered up; thus one can see at a glance just what a particular tire has been doing.

The accessory display in the show-room is one of the best. Thirty-five feet of heavy plate glass is used for the show cases. These have a splendid appearance and display the parts to the best possible advantage. In the busy season four men are employed in the accessory department and there is a cast iron rule that no one is allowed in this department except those employed there. The accessories occupy two floors, the department on the lower floor being for the convenience of the repair men. About \$30,000 worth of accessories are carried, nearly 60 per cent. of which is sold wholesale.

As the business expands another storey will be added, and to prepare the way for this an elevator shaft already exists to connect the three floors. This new storey will be used principally for storing cars during the winter months and those cars which have been repainted and varnished.

To take care of the business outside Peterboro, two branch garages are maintained, one at Millbrook and one at Norwood, and five salesmen are kept on the road all the year round. These men canvas the entire territory and distribute huge quantities of literature of all the lines carried and whatever special advertising material Mr. Duffus is using at the time. All this literature is marked with the Duffus Motor Sales stamp.

From time to time special pamphlets are prepared for distribution. These are handled by the salesmen on the road who circulate them through the territory. One of the best mediums of distribution is the country school-house. Large quantities of literature are left there and the school children, from all parts of the country, take it home to their parents who are usually farmers. In this way advertising matter reaches prospective customers who are otherwise hard to reach.

Besides handling automobiles, accessories and repairs, the Duffus Motor Sales are distributors for trucks, tractors and tractor implements. They reckon on selling about 300 automobiles annually and last year they succeeded in selling 18 tractors. This year and in succeeding years they plan to dispose of 50 tractors.

**I**N discussing with M. T. I. how such a business was built up Mr. Duffus said:

"In the very beginning I adopted a system which



JOS. J. DUFFUS.

I call "general push"; that is to say, behind every transaction there was thought, push and energy. The value of publicity and demonstration was impressed on me right early. If there was going to be a gathering of people anywhere, that was where I would be with my literature and machines. Consequently every fall fair since I started selling automobiles has seen me as an exhibitor. I was the first automobile exhibitor at these fairs and for years was the sole exponent of the new means of locomotion. Needless to say this policy gave me great publicity and brought numerous sales. It brought me in touch with every farmer in my territory and as a consequence I believe I am the best known man for miles around Peterboro. I can claim without stretching the point that I know every farmer in my territory, in fact, there isn't a front lane nor a back lane, a good road nor a bad road in Peterboro County unknown to me.

"I have the utmost confidence in my employees and I never ask one of them to do what I would not do myself. My policy has been the same with my customers; and if I promise a man anything I see that it is carried out and insist on every man in my employ following the same principle.

"I never allow a business communication to be neglected even though the prospect of doing real

business be remote. One can never tell what possibilities there may be in the most unpromising letter. I had this brought home to me very forcibly on one occasion and the lesson has stuck for good. It happened like this:

"I got a letter from a man in the woods away to the north of Peterboro, enquiring about a car. As I knew there was nobody around that part of the country, save a few homesteaders and woodsmen, I didn't attach much importance to the communication so far as doing any business was concerned. But, in accordance with my policy—never to neglect a business letter—I decided to look the man up. I took one of my men with me and motored out.

"When we got there, we found our prospect was a homesteader. The place looked mean and poverty stricken; and to intensify the miserable appearance it had been burned out the year previous.

"We entered the house and found it in the same ill-kept condition. From whatever angle we looked we could see daylight through the house. Our prospect was not in the house but his good wife directed us to where he was cleaning up brushwood. When we found him, ultimately, he presented the same dilapidated appearance as the place. However, he was eager to talk about cars as we soon found out.

"In the end we sold him a car and in conversation learned of several other men in the district who were interested in cars. We decided to stay for a few days, and in a week's time we sold eight cars and had no less than five instructors in the district at once. That sounds like good business and it all resulted from a letter which we imagined offered little prospect.

"We investigate everything, and believe that practically every man is a prospect, for cars, trucks, tractors or accessories.

"**W**HEN we took on the agency for the Fordson tractor we started in by giving extensive demonstrations. In our first tractor season we spent \$2,500 on demonstrations alone. We tried the tractor out on plowing, harvesting, hauling, belt-work, etc., etc., thoroughly convincing ourselves and the farmers in our territory of the tractor's utility as a labor-saving and effective farm machine. These demonstrations have sold the tractor around these parts, we sold eighteen last year and expect to sell fifty annually.

"We have instances of our machines selling themselves.

"A farmer, four miles out, bought a tractor and commenced plowing. One of his fields was near a road where the farmers pass going to and from the town. Several of these farmers seeing the tractor at work watched it with considerable interest, the work pleased them with the result they made enquiries and we made several sales. We don't require to demonstrate the tractor now."



This splendid accessory department is a feature of Duffus Motor Sales.



# THE IRON JINX: By B. J. PAULSON

Illustrated by LOUIS KEENE

Continued from  
March Issue



He staggered forward doggedly, obeying to his last ounce of strength the presence at his side.

THE front axle of the tractor had momentarily lodged against an obstruction—a large boulder, Flanders intuitively surmised. It furnished the precious brief hesitation that gave Flanders and the Jinx a narrow fighting chance—for he knew what lay ahead. A full realization of the situation flashed in his brain like powder touched off by a match the instant the front wheels of the tractor left the horizontal plane.

With a mighty effort Flanders bore down upon the foot brake of the Jinx and with lightning swiftness he disengaged the forward speed and shot the reverse lever into place. There was a rasping of transmission pinions sliding in and out of mesh with the counter-shaft gear and then, just as the reverse pinions slid into place and transmitted the mighty engine's power to the great drive wheels, the life-saving boulder that had momentarily stayed the tractor's progress fell away under the eleven odd tons of dead weight that pressed against it from above. Fortunately the rear wheels of the tractor were still resting on comparatively level ground although the front truck was headed straight toward destruction.

There was a momentary slipping of the broad-faced drivers as the wheels reversed and the dislodged boulder fell away—a grinding, heartrending, crunching screech—and two lives hung in the balance! And then the heavy, sharp angle lugs on the wide faces of the giant drive wheels bit deep into the hard earth, swept clean of snow at this wind-exposed point, secured a firm tractive grip and slowly—oh, very slowly!—the great hulk of steel and iron backed away from the invisible hand that was clutching at it from out of the storm and darkness.

Ted Flanders stood at the wheel like a graven image—one hand on the wheel and the other delicately manipulating spark and kerosene needle valve, feeding fuel to the laboring cylinders in exactly the right proportion and retarding the spark to a nicety that could not have been excelled under the most favorable conditions. And strangely enough, a light was focussed in front of him so that he could see what he was doing.

All of Flanders' energies were concentrated upon the task in hand. Grim, hard, taut, he held the tractor to its task with a firm, determined hand until well clear of the pit-fall and then, with a whistle of relief, brought the Jinx to a safe anchorage.

He now bethought himself of his passenger. She had uttered no sound and he had momentarily quite forgotten her presence. She was clinging to the hot-air manifold with her mittened hands, staring at him, lips parted and the color quite gone from her peach-bloom cheeks. She was still holding the flashlight; she had held it steadily focussed upon the operating mechanism of the tractor during the brief struggle with the forces of gravitation, thus enabling Flanders to act with precision, unhesitatingly.

"I'll say that was one close call," shouted Flanders, grinning pleasantly. "And thanks awfully for helping with the light. If you hadn't held it just as you did so that I could see what I was doing we might have been somewhere else right now."

"The coulee!" murmured the girl—and with that she permitted the electric flashlight to drop from her hand and slumped down upon the floor of the tractor cab in an inert heap.

"Well I'll be cow-kicked by a mule!" gasped Flanders in mingled surprise and consternation. "She's gone and fainted!"

Here was a pretty kettle of fish indeed—a fainted girl on his hands and some seventeen miles from town and a doctor, for Flanders was sure that this was most decidedly a case for the doctor. Never in his life had he had an experience with a person in a swoon—and then to have such a responsibility as this thrust upon him! Rescuing an eleven-ton tractor from the brink of a precipice was mere child's play when compared to this. What should he do?

Ah, a happy thought! He made a frantic dive into his inside coat pocket and produced therefrom a much-thumbed and soiled vest-pocket memorandum book that once had gold-gilt edged leaves—presented with the compliments of a farm machine agent who believed in advertising, as was modestly indicated on the front cover in gilt letters. This precious volume was a compendium of general information. Not only did it contain tables of weights and measures and a list of holidays but it also contained within its small compass several pages under the general caption: "What to do in case of accidents."

To these pages Flanders turned feverishly after picking up the electric flashlight and placing it in an advantageously illuminating position. There were complete and explicit directions telling what to do in cases of drowning, snakebites, internal poisoning, burns and various other gruesome possibilities, but there was not a word about the most important thing of all (to Flanders)—how to revive a woman in a swoon. Flanders hurled the faithless volume into a corner of the cab and as usual, when in doubt, resorted to his own judgment.

He had an idea that the right thing to do would be to pour a bucket of cold water over the unconscious one's face and to loosen her clothing—but heaven forbid! She might catch her death of cold unless he drew hot water from the cooling tank of the tractor and permitted it to stand for several minutes to cool—and meanwhile she might die!—so thought Flanders. And as for loosening her clothing—he blushed at the mere thought of such an impropriety on his part.

While cogitating thus he had propped the relaxed body of the girl in a corner of the tractor cab in a sitting posture. Having discarded as impractical what he considered the most approved methods of restoring

her to consciousness he began desperately to chafe her hands and pump her arms up and down vigorously. After a brief interval of this the patient gave a few spasmodic gasps, opened her eyes groggily—and promptly lost consciousness again.

"Almost had her that time!" thought Flanders exultantly and then aloud he shouted: "Wake up, wake up!"—as if she were asleep. He renewed the pumping exercises and at length, after a few preliminary shivers, the girl opened her eyes, straightened up and asked:

"What happened? Where am I?"

"You're quite all right, Miss," Flanders assured her, "and you're on board my fast express train, the Iron Jinx—the good old tractor that's as safe as the rock of Gibraltar. Guess you've had too strenuous a day. Just take it easy and you'll be yourself again in no time at all."

When the girl began to show signs of returning consciousness Flanders had eased her position by placing his right arm around her shoulders to hold her up and protect her from contact with the cold sheet-metal wall of the cab. In a moment they both became aware of this somewhat unconventional attitude for Flanders had overlooked the matter of removing his arm. He was not a "ladies' man" in any sense of the word and upon discovering what he had done he hastily withdrew his arm and stammered in some embarrassment:

"Er—I—I beg your pardon. I was trying to make you comfortable."

"Thank you," responded the girl graciously, favoring him with a smile. "Its cold, isn't it?"

Flanders agreed that it was "quite some chilly" as he assisted her to her feet and then remembered a flask of brandy that he usually carried in his traveling bag. He burrowed through a tangle of socks, work shirts, handkerchiefs and various other accessories of wearing apparel and shortly found the object of his quest.

"Here—better take a swallow of this; it will warm you up," he said, unscrewing the cap and proffering the flask.

"Thank you, no." She eyed Flanders coldly and drew away from him.

"Excuse me—and I didn't mean it that way," apologized Flanders. "Don't use the bloomin' stuff myself. I've packed this one bottle around with me for about a year. Always a chance that it might come in handy in an emergency—although I plumb mashed up a bit at different times; been there myself, too. Nothing like a little dose of this stuff in cases like that. They say it's good rattlesnake medicine, too. Rattler tangled in my pants leg once while I was doin' some tinkering with the Jinx—but they were a cheap pair of pants an' not worth savin' so I didn't try out my medicine on 'em."

While delivering this monologue Flanders replaced the bottle in his traveling bag after which he removed his heavy bearskin top-coat.

"Here, put this coat on," he commanded. "You're freezin'."

"I—I'm all right. I'm feeling better now. Thank you just the same. Please put your coat back on; you have a bad cold. And—and I beg your pardon for my discourtesy a moment ago, Mr. —"

"Flanders; Ted Flanders," grinned that individual. "And don't you worry none about any discourtesy to me. I admire you the more for the way you acted. Don't mind my sayin' that, do you, Miss —?" He grinned the question.

"Springer; Fern Springer is my name," she smiled back at him. "And if you insist on paying me compliments I'm sure I don't mind in the least as long as you



put them in the way you do. I—I believe I'm a pretty fair judge of men. You know, I worked in a hospital for over four years. You may consider that as a compliment."

"Thanks; and I sure do. I consider it a compliment to be permitted to talk to you at all, Miss Springer—an' that's no taffy." Flanders was sincere about it, too. During the last few minutes he had discovered that this girl was beautiful. No need to describe her; she was just beautiful—the clean, fresh, stimulating, vigorous beauty that only the wholesome outdoor girl can possess. And Ted Flanders knew intuitively that her character was just as beautiful and wholesome as the rest of her.

"I'm getting tired of holding this coat," protested Flanders. "I know it aint as nice lookin' nor as clean as it might be, what with associatin' with greasy tractors and such like, but —"

"Oh, very well—if that's the way you feel about it I'll wear it just to prove to you that I'm not uppish nor afraid of honest grime, although I can't see anything whatever wrong with the coat," stated Miss Springer. "At the same time I want you to know that I do appreciate your kindness and thoughtfulness and am ever so grateful. But as soon as I'm nice and warm you must take the coat back again. It's the only condition on which I'll accept your generous offer. Is it a bargain?"

"Anything you say is a bargain—just so you agree to wear the coat," grinned Flanders as he steered Miss Springer's mittened hands into the cavernous arm holes of the coat, after which he assisted her in buttoning the cumbersome garment snugly.

"This is delightful. I feel warmer already. And thank you so much, Mr. Flanders. I don't feel right about depriving you of such a wonderful coat, but you know it was your doing and not mine. And now, if you'll excuse me, I believe I'll sit down on the floor for a little while. I feel a trifle weak and shaky—my nerves, I guess. Aren't girls the helpless things?" She smiled up at Flanders apologetically.

"If you're helpless I'll say I'm a hopeless cripple," countered Flanders. "What you've been through today would have just naturally killed off any ordinary person. You have a rest coming to you—an' I'll have the porter of this car help make you comfortable right away." Saying which Flanders excavated several large handfuls of cotton engine-wiping waste from the ample tractor tool box and spread it upon the floor of the cab as a cushion for his passenger to sit upon.

With a murmured "thank you" and a gracious smile Miss Springer seated herself upon the improvised cushion, crossing her legs tailorwise for comfort and warmth, and tucked the ample folds of the fur coat underneath her.

"Now I'm as snug as a bug in a rug," she shouted up at Flanders as she turned up the great collar of the coat about her neck and ears so that it all but swallowed her head and features. Her altogether charming face peered forth piquantly between the furry folds like a pink rose-bud breaking through a leafy bower.

"That's good," replied Flanders as he lowered the front curtain of the cab once more and fastened it in place, for until now he had not had time to do this since he had rolled it up just prior to the near-plunge into the coulee. The snow had been breezily surging through the opening into the cab so that a little drift had accumulated on the floor. "Might as well make yourself as comfortable as you can because we're going to camp here for the rest of the night—or at least until this blizzard plays itself out," announced Flanders. "No sense in trying to navigate farther in this storm—we'd only drop into one of your cute little coulees. And as for making a try for it on foot I'm thinking we'd probably travel round in a circle and wind up by furnishing a winter grub-stake for a bunch of hungry coyotes."

"Ugh!—don't talk about it," pleaded Miss Springer. "It's really quite cozy and warm in here and I'm perfectly satisfied to remain. So we'll just let it storm. And inasmuch as we have a long evening before us I want to be entertained. You must tell me about some of your exciting adventures with tractors for I'm sure you have had lots of them. Didn't I hear you call this tractor a 'jinx' or something like that? Why did you call it that? Please sit down here beside me and tell me all about it. There's room for you on the tail end of this coat."

Somewhat diffidently Flanders seated himself on an overflow fold of the fur coat for the coat was miles too big for its present occupant. He would have shared the coat with her quite willingly in another way but—

Anyway, Flanders obediently launched into an account of his adventures with the Iron Jinx, relating

the various episodes that led up to the present situation. At first the girl sat wide-eyed, alive with interest, punctuating his tale with exclamations and laughter, for Flanders was a good story-teller. But as he continued her eye-lids began to droop and before long he found himself talking in hoarse shouts to a sleeping girl. Yes, she had actually fallen asleep.

The rhythm of the faithful tractor engine which was still pounding away, the whine of the wind and the steady flow of Flanders' narrative combined to exercise a soothing, narcotic effect upon the tired, overwrought girl and slumber claimed its reward.

Flanders got to his feet once more upon having made this discovery and threshed himself with his arms for he was now chilling uncomfortably. But he smiled to himself as he thought of the girl occupying his coat. She would be warm, at any rate, and for that he was sincerely glad. He looked down upon the sleeping girl with an almost reverent tenderness—a feeling quite new to him. It was fortunate that she had fallen asleep; she could not protest now against continued occupancy of the coat—his coat! That coat would never be the same after this. No, never! It would be an almost sacred thing to be put away and guarded carefully. Lucky coat!

Flanders suddenly caught himself soliloquizing in this strain and at once proceeded to kick himself, figuratively, muttering something about being a "blithering ass" for, be it known, Ted had always considered himself somewhat of a cynic where women were concerned. He had never had an affair of the heart and he certainly did not intend to begin now at his present sophisticated and more or less advanced age of thirty years. Not much!

However, Flanders took a cold mental plunge back to realities for his teeth were chattering and he was shaking like a short-haired dog on a cold doorstep. He was beginning to feel weak and dizzy, too, now that he had time to notice it. His cough, which he had valiantly suppressed to a certain degree since taking Miss Springer aboard, was growing worse and he was distressed by a severe pain in his side and chest.

Rummaging through the indispensable traveling bag he brought forth two flannel work shirts and an old sweater. Removing his coat and vest he slipped on the extra layers of clothing and replaced his outer clothing. This ought to keep him warm. But no, it didn't. The chills persisted. Finally he resorted to the emergency bottle of brandy and took a generous gulp of the fiery liquid. This stimulated and warmed him temporarily but the re-action proved more distressing than the original aggravation.

And so began a hideous night. He'd beat himself with his arms until the effort exhausted him; then he would stamp his feet, alternating again with the vigorous thrashing. His brain began to reel—and it was not from the effects of the brandy. The hours dragged on—a wild night-mare. Where was his warm fur top coat? Ah, yes, the girl had it to be sure. But what business did she have with his coat? Why had he denied himself this small comfort? His delirious brain asked these questions time and again—and each time he would suddenly remember. Then he would curse himself for an unprincipled barbarian. A wave of infinite tenderness would flood his heart and following would come a wave of bitterness—bitterness that he should come to this hopeless pass at this particular time. For was not this girl entrusted in his keeping? And how could he deliver her safely to her home if this madness that was coming over him robbed him of his strength? At these moments he gritted his teeth and promised himself that he'd see her to her destination if it was the last act of his life.

Gusts of icy wind blustered into the tractor cab and the curtains flapped wildly. The snow sifted in steadily and piled itself into sizable drifts on the cab floor. The sleeping girl was covered with a mantle of white. It was most decidedly a bad night and a bad situation.

Still Flanders fought on. He must not give in. He began to realize that he was a very sick man. In fact, he was convinced that the closing chapter of his career had arrived. Once, many years before when he was a boy, he had had an attack of pneumonia. He recognized the dread disease in his present affliction. The hollow, barking cough that convulsed him at intervals seemed to tear his chest and each spasm left him weak and exhausted. But through those bitter hours his will power and wonderful reserve vitality exerted themselves and he maintained the unequal struggle for supremacy—his tortured mind and body against the ravaging imps of pneumonia and the relentless demons of gnawing, marrow-freezing cold.

It was possibly midnight when the tractor engine stopped. Flanders had taken on only fuel when starting the trip to carry him safely to his delivery destination,

allowing a generous margin for any ordinary contingencies that might arise. That margin had not proved sufficient, however, to meet the present emergency and had been consumed entirely.

Flanders, though half delirious, remembered his engine, like the good expert he was, and struggling out into the storm opened the cooling system drain cock so that the water, which was still warm, would drain out, thereby forestalling the possibility of a frozen water jacket, cooling tank and feed pipes, with attendant damage. After performing this duty he managed to get back into the tractor cab, though weak and shaking, and succeeded in fastening the rear cab curtain behind him.

Deprived of its only source of heat the interior of the tractor cab dropped quickly to the temperature of the outside atmosphere. The electric flashlight had burned out, too, leaving the occupants of the tractor cab in total darkness.

It was, perhaps, a matter of an hour or so after the engine had stopped that Flanders, during a moment of mental clarity, discovered that the blizzard had abated somewhat. At the same time he was aware of Miss Springer stirring wakefully on the floor. The chill of the keen air had evidently bitten through her heavy wrappings.

"Wh—where am I?" came a small muffled voice from the opaque darkness in the region of the cab floor.

"Y-y-you're all right," chattered the shivering, fever-ridden Flanders through blue lips, and with numb, trembling fingers he managed to light a match which the wind promptly blew out. "Did you h-h-have a n-n-nice nap?"

"Upon my word—I do believe I actually fell asleep! Yes, now I remember, of course. I was so tired and cold. And then I was made so warm and comfy—and someone told me funny fairy tales about an iron jinx and before I knew it I was drifting into the land of dreams. Dear, dear! But—why, Mr. Flanders, I still have your fur coat—and you freezing to death! Please help me up." She groped for Flanders' hand and finding it, struggled to her feet, quite stiff and numb from the cramped position in which she had been reposing. As Miss Springer gained her feet Flanders was seized with a violent paroxysm of coughing that caused him to stagger against the girl and cling to her for support.

"You are ill—dreadly sick!" cried Miss Springer, now thoroughly awake, as she gripped Flanders' arm. "And it's all my fault. Oh, why did you make me wear your coat and then let me fall asleep? Here, you put this coat back on right this minute!" She was out of the clumsy coat almost in less time than it takes to tell it and held it for Flanders.

"I—I'm all right," gasped Flanders as he obediently found his way into the coat. "Just a little cough; soon pass over. I always was a musical bird. Wish you'd keep the coat, though."

"I've kept it far too long as it is," stated Miss Springer crisply. "Where is the flashlight?"

"Burned out."

"The engine has stopped. Why isn't it running?"

"No more kerosene—all used up."

"When did it stop?"

"An hour or so ago, I guess—don't just remember."

"And you without a thing to keep you warm—and didn't tell me!" accused Miss Springer. "Have you any idea as to the time?"

"It was one a.m. the last time I looked at my watch—about a half an hour ago," replied Flanders.

Holding the edge of the nearest cab curtain aside Miss Springer peered out into the night. "The storm seems to be practically over," she announced. "We must go on now. It is only a little over a mile to my home from here."

"If—if you think you can make it safely you'd better go on," said Flanders. "I'm quite all right now—and I'll just camp here until morning."

"You'll do no such a thing!" sternly stated the new commander. "You're going with me."

"Wouldn't look right if I went to your place," protested Flanders weakly. "Can't do it."

"Don't be silly. There is no convention in a situation such as this. Come!"

Miss Springer struggled with the rear cab curtain whereupon Flanders came to her assistance and with trembling, fumbling fingers unfastened it. They stepped into the open and were met by an icy gust of wind carrying a cloud of swirling, powdery snow in its frigid embrace. A cold, bright quarter moon filtered through a broken sky as flotillas of clouds sailed swiftly across the heavens. The two wayfarers started forward on the last leg of their journey.

To be continued



# CANADIAN MOTOR, TRACTOR AND IMPLEMENT TRADE JOURNAL

Published on the fifth of each month by

The MacLean Publishing Co., Limited  
TORONTO, MONTREAL, WINNIPEG

JOHN BAYNE MACLEAN,  
President.

H. T. HUNTER,  
Vice-President.

H. V. TYRRELL, General Manager.

LONDON, ENG., THE MACLEAN COMPANY, OF GREAT  
BRITAIN, LTD., 88 FLEET STREET, E.C.

BRANCH OFFICES: Montreal, Southam Building, 128 Bleury  
Street; Winnipeg, 1103 Union Trust Building; Vancouver,  
39 Tenth Ave. West; New York, Room 620, 111 Broadway;  
Chicago, 1401 Lytton Bldg.; Boston, 734 Old South Building.

SUBSCRIPTION PRICE—\$1.00 A YEAR.

OFFICE OF PUBLICATION—143-153 University Ave., Toronto.

Vol. II. TORONTO, APRIL 5, 1920 No. 4

## A VOICE FROM THE WEST

THE following letter by an Albertan implement dealer shows the keen interest our readers are taking in the question of increased margins.

Last month we published the views of a Saskatchewan dealer on this subject and we would like to hear from more of our readers. It is a live subject and an important one and should be studied closely by both dealer and manufacturer.

The question of organization brought out in the following letter is important. M. T. I. has been talking organization for months and several articles have appeared on the subject. Until the dealers and—yes—the manufacturers, realize the need for such an organization and get together and put it "across" little good will come of all the agitation.

There are so many things besides increased margins to be cleared up—things that can only be settled by organization.

The CREDIT question, the much talked of SERVICE problem—who should pay for it—a sane and safe means of financing the farmer so that he can buy for cash, thus benefiting himself, the dealer and manufacturer, etc., etc., are problems all calling for immediate solution.—*Editor.*

## ORGANIZATION THE THING

DEAR SIRS, we are very pleased to note the interest you are taking in the matter of increased margins for the implement dealer. If the system of factory governed retail prices is to continue, it is high time that they should be placed where the dealer can live.

We received a contract lately for a plow in great demand in this district. The cost is \$155 net, and we are asked to sell for \$180, less than fourteen per cent. We are asked to add 20 per cent. to repair lists, which would give us less than 17 per cent., and we pay the expenses! It would be interesting to know if the factory runs on any such pitiful margin. We refused to accept the conditions which were waived, with the explanation that they were only inserted to protect the manufacturers.

The wholesale prices are advanced in other lines 10 to 15 per cent. and no increase additional for the dealer.

In taking up this question with the managing director of the largest firm in the business, the writer was informed some few years ago that the dealer was not entitled to a percentage, but only a small brokerage. His firm has the courage of their statement, as their margins are less than at that time, while the dealer's expense has increased 50 per cent.

We believe that individual effort by the dealer will always prove futile, and we are firm believers that only by united action can we get redress. The implement associations in the various states are live and powerful organizations, and their complaints get a ready hearing, and just causes for criticism are promptly remedied. There is no reason on earth why the dealer should be the tool of the interests longer.

In the old days of haphazard credit, the profits were living ones, to-day the companies are taking few chances. Irresponsible dealers can get no contract

worth having, and farmers' paper is so closely scrutinized that a retailer is worse than foolish who takes doubtful paper.

Personally we take the stand that if the farmer cannot get accommodation from the bank, we will not get it for him, which is what long time amounts to. No farmer, or anyone else for that matter, can afford to pay 6 per cent. flat forfeit, in addition to bank interest, for six or seven months' accommodation.

NO ONE can get credit here on repairs, not even a day, and in the case of machines, we argue long, and in every way we know for the cash, and if necessary we accept only paper that is absolutely gilt edge, and from persons who can get the money from the banks, but prefer not to—heaven only knows why. We might do more business by changing our terms, but every night we know exactly what we are worth, and lose neither sleep nor discounts.

It will be a red-letter day when Alberta has an organization like Saskatchewan, and we are ready to boost that time with all our experience and all our resources.

The writer has over ten years "blocking experience," several years wholesale and retail bookkeeping, and we are fully convinced that remedial measures lie in our own hands by organization; know what we want, and then we can get it. When that is the case, we are convinced that the manufacturer, the dealer and the farmer, will all benefit. Mail order is a weak-kneed bugbear, and the good farmer knows it. True, in a new country they will always get the trade of the inexperienced beginner, and the ignorant immigrant. Every good farmer, and only those are worth considering, knows the benefit of a good machine with an organization and reputation behind it,

any other time, and it requires considerable time for the oil to circulate throughout the engine. Until it has reached all parts, the engine should be run slowly and without a load.

Thorough inspection of bolts is another essential and must be more frequent while the machine is new. Although a loose bolt may not cause a great deal of damage, it may work out of place and fall into part of the moving mechanism. The farmer buying a tractor for spring work will want to put it to plowing as soon as weather permits. Therefore it is advisable for him to get his machine as early as possible and put it in condition in advance of the busy season.—*Farm Implement News.*

## THE DEALER'S RESPONSIBILITY

NOT long ago while driving in the country we came to a farm where outhouses and farm machinery were huddled together in an amazing manner. Tractors, plows, spreaders and all the rest were lying promiscuously between barns and pig runs. There was no attempt to shelter the machines from the wind and rain. Even the tractor was lying exposed to every sort of weather that cared to come along. It was red with rust and looked as miserable as an abused tractor could look.

It is inconceivable why a man will spend hundreds of dollars on a machine and then neglect to give it proper attention. Yet this is happening every day and the only man in a position to relieve the situation is the dealer. We know it is hard to keep preaching day in and day out the same lesson but unless the dealer looks after his machines and sees that they get fair treatment he is likely to be the loser.

He should impress on every prospect the necessity of taking proper care of tractors, separators, milkers and every other machine used on the farm.

Some farmers are careless, they spell their name that way.

Mr. Dealer, a careless customer in your territory is one of your worst enemies. He neglects his machines, and overworks them and still expects to get maximum results. If the machine fails to deliver the goods the machine is to blame. That is how the farmer works it out and it is up to the dealer to teach him different. A persistent educational campaign—both by personal calls and literature—will go a long way to help the situation. The dealer is only to blame in so far as he fails to instruct his customers in the proper methods but his responsibilities are ever present.

## SPECIAL ARTICLES

DON'T fail to read the article on page fifteen of this issue by L. G. Heimpel, farm manager at the Ontario Agricultural College, on the proper method of laying out a field for tractor plowing. Such an article is of great importance to the implement dealer.

It is a clear and concise exposition of the most important work the tractor is called on to do. If the dealer has a thorough grasp of the methods to be employed in the various operations of the tractor he is better able to sell to the farmer this, his most expensive machine. We expect to follow this article by another from the same pen on "Tractor Plow Adjustments and Hitches."

Of course you are reading Mr. Dixon's articles for garagemen and accessory dealers; if not, you had better begin with the one in this issue on "Better Business Methods." While this article and the preceding ones are primarily for garagemen, they are in principle equally applicable to all dealers.

"THE 'good' road as a fundamental factor in national life and activity," says the *Good Road Bulletin*, "has come to be recognized universally." If the farmers and men of the automotive trades are to derive any considerable benefit from these roads, it behooves them to keep themselves interested and boost, boost, boost. The importance of good solid roads to the farmer, dealer and automobile owner cannot be overestimated.

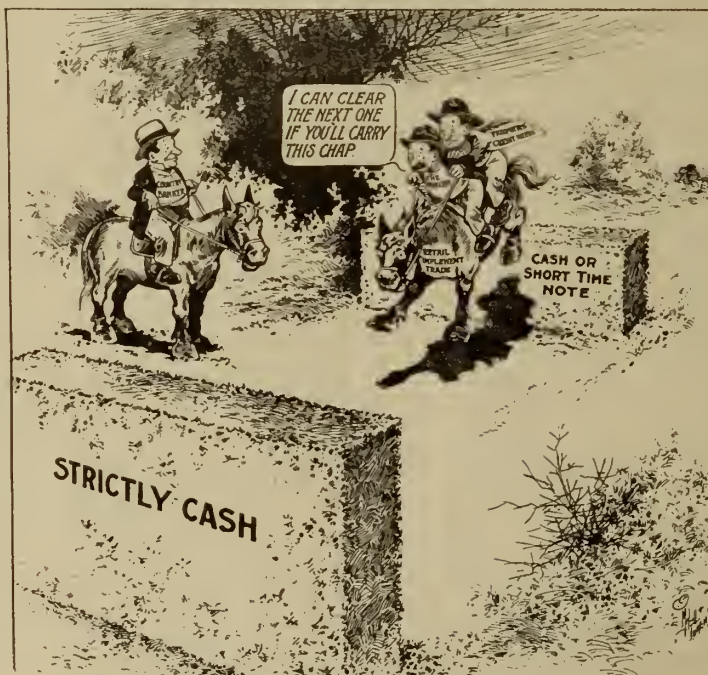

Carrying Too Much Weight for the Big Jump

—*Farm Implement News.*

and few grudge the dealer a fair return for the service and effort that is universally and rightly demanded.

We are just commencing in the retail here, and will be glad to have you put us in touch with any nucleus of an organization or progressive dealers who have the interest of the trade at heart.

## BREAKING IN A TRACTOR

A GREAT deal of difficulty may be avoided in tractor operation by greater care in breaking in a new machine. The responsibility of this work rests largely with the dealer and it will pay him to make a thorough study of it in order to reduce the service cost later. In a new tractor bearings are closely fitted and points may be tight. Bolts may not be tightened to the right degree and may work loose. These points demand close attention during the tractor's first few runs under field conditions. The first matter of importance is to see that the machine has plenty of oil of the right kind. Otherwise it cannot run smoothly. More oil is required at the start than at



This article by L. G. HeimpeL on "Laying Out a Field for Tractor Plowing" was written at the request of the editor, for the benefit of our tractor dealers. Plowing with a tractor requires methods of laying out different from those usually followed when using horses and ordinary plow.

The farmer usually experiences considerable trouble when using the tractor for the first time. It is with the purpose of overcoming this difficulty that this article is written.

In order to sell the tractor successfully the dealer should be familiar with its every operation. He should know the proper speeds to employ in plowing, harvesting, etc., and above all should be perfectly familiar with the system of laying out a field—EDITOR.

# LAYING OUT A FIELD for TRACTOR PLOWING

By L. G. HEIMPEL  
Farm Manager O.A.C

the machine reaches the field. The following is a discussion of some of the best methods of laying out a field which we have tried out.

THE ideal way to plow any piece of ground with an engine would be the continuous furrow. That is starting at the fence, turning the furrows out and finishing at the centre of the field or starting at the centre and turning the furrows in. This plan does away with all empty travel but it requires round

The best way to lay out a rectangular field is in lands. The part of the field to be considered first is the headland. Some operators prefer the continuous headland, where the width of the headland is staked out all around the field to be plowed, either to or away from the face, after the rest of the field is finished. While it looks like a good plan, theoretically, it is a plan which requires considerable trouble to follow, and we have found that on the average farm it is an easier and quicker plan to leave headland strips across the ends

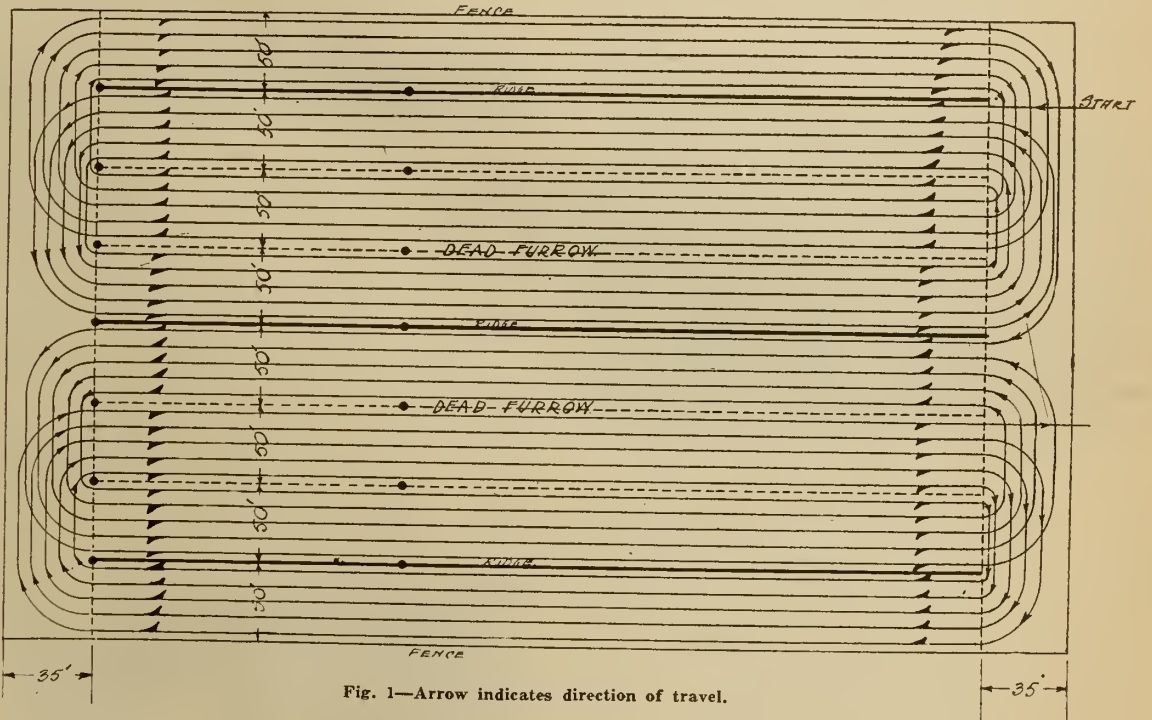

Fig. 1—Arrow indicates direction of travel.

TO THE new tractor dealer and tractor owner the subject of tractor plowing does not present any difficulties until he gets to the field with the outfit. Then he probably tries to plow in the same manner in which he has been accustomed to plow with a team. It is here that he runs into troubles. He finds it is impossible to turn as short with the tractor as he can with a team. He also finds that he has not allowed for a wide enough headland; this is eye-opener number two. After the excitement of the first day is over he will likely do some thinking as to how he should have gone about the job in the first place. The result will be that he will work out a system of his own which may or may not be to the best advantage of the tractor.

One of the objectionable features of going into your first plowing job blindly then experimenting your way out of it are first of all the fact that the whole neighborhood is likely to be watching and a misstep at the outset is not a good advertisement. Then there is the matter of lost time. A tractor is supposed to plow acres and if the first day or two will not show acres flopped over the opinion of the on-lookers as to the tractor's value for plowing will be based on those few days work, of course. Besides this there remains the fact that the owner cannot afford to lose his time experimenting when it is just as easy to plow to a definite plan from the moment

corners of a large radius which can only be maintained in a very large field and probably require the aid of a horse outfit to prevent them from becoming too sharp. Plowing around a curve is also very hard on the outfit. Since it is only very seldom that one finds a field adapted to this plan on an Ontario farm it is unnecessary to consider it any further.

of the field only and to lay the rest of the field out in lands.

The first thing to do is to measure off the width of the headland at each end of the field and plow a shallow guide furrow across each end of the field. This furrow serves as a guide to the operator in the raising and dropping of the plows and is necessary to make a neat job.

The remainder of the field can be laid out to best advantage as follows:—

Choose a straight side of the field, which is at right angles to one or both headland furrows, to measure from. Measure the width of the field at its widest end, if there is any difference in width at the ends, and divide this width into a number of lands of four equal strips each. The width of each strip may be anywhere from forty to seventy feet wide—each land is of course the width of four strips. The field may be laid out in any number of strips which is a multiple of four. The reason is that it takes four strips to make the most convenient land for the tractor plowing outfit.

REFERRING to Figs. I and II it will be noticed that the field is 400 feet wide. This width can be readily divided into 8 strips of 50 ft. each.

Fig. I shows where the first back-furrow or strike out will have to be made when plowing away from the fence. The first furrow or strike out will be made along the first line of stakes at the right side of the field, moving in the direction indicated by the arrows and throwing the furrow toward the stakes. When the end is reached turn to the left and come back along the second strike out which is 150 ft. from the first one. Now keep on plowing until strips number 2 and 4 have been plowed. Then

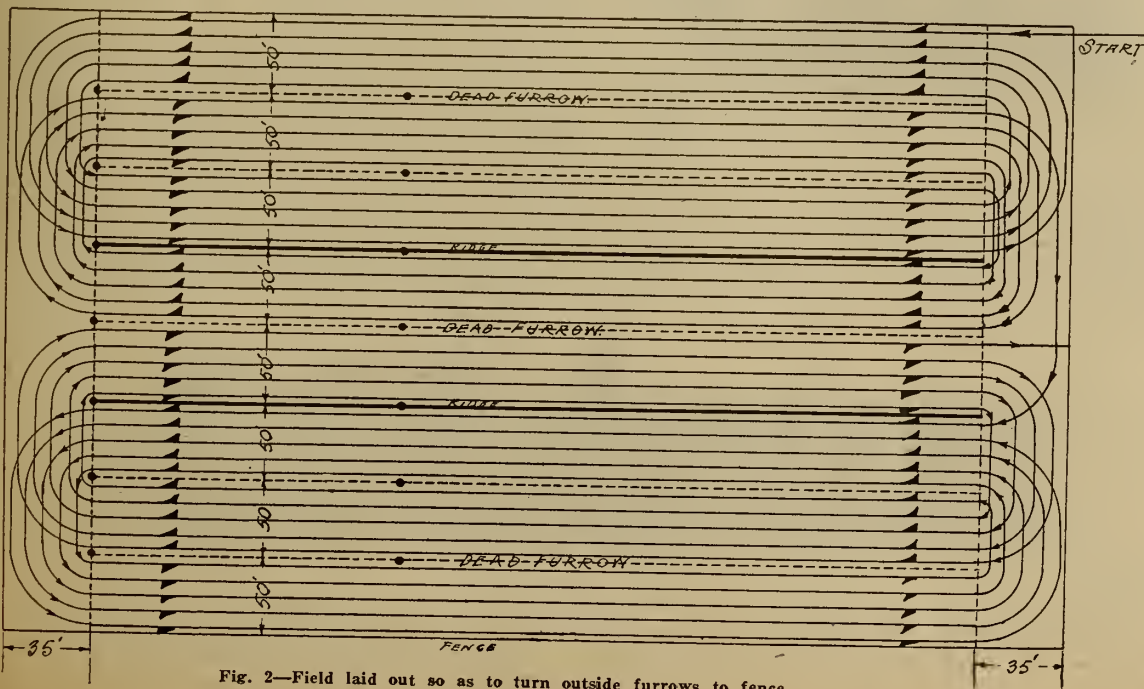

Fig. 2—Field laid out so as to turn outside furrows to fence.



plow strip number 3, which is simply a continuation of strip No. 2, in the same direction as two, turn to the right and plow strip No. 1 away from the fence. The dead furrow will be between strips No.'s 2 and 3.

Fig. II shows where to strike out when plowing to the fence. By following the arrows one can readily trace the courses followed by the outfit. It will be noticed that the shortest turn necessary in this field is around a fifty foot land while the greatest length of empty travel by the machine at any time does not exceed 150 feet. This method eliminates all short turns and reduces empty travel to a minimum.

It looks like a great deal of work to measure the width of a field to get this method started, but measurements of some kind are necessary no mat-

ter what plan is followed. By the use of a tape line two men can lay out a thirty or forty acre field in less than two hours. The work will be accurately performed and the measurements once made should be preserved for future use in laying out the same field.

#### Striking Out and Finishing

WHILE it is possible to do first class work striking out and finishing with the engine it is not advisable to do so at the outset of a new operator's experience. Best results can be obtained when the striking out and finishing are done with horses. It is good policy to let a teamster strike out or finish a whole field at once. This makes for best results

and no lost time for either the team or the engine.

A headland width of thirty feet is sufficient for ample turning room for most small outfits but thirty-five feet may be necessary for some.

#### Planning a Farm for Tractor Work

Sometimes it is necessary to rearrange the whole farm in order to create conditions so that the engine can operate to the best advantage. In such cases it must be remembered that the longer the fields, the fewer the obstructions, and the more uniform the drainage, the less empty travel, the fewer the break-ages and the less lost time will be the experience of the man at the wheel.

# THE "EATERACRE" AGENT

From "HYATT'S TRACTOR TRACT"

HE wasn't talking about me—at least he didn't think he was. He was talking to some of his salesmen, telling them some things about selling tractors. But the longer he talked and the more he said, the more I knew that he WAS talking about me!—about me and several thousand fellows just like me—and I caught the arms of my chair—and I listened.

He managed a big implement house way down in Dallas. Yes, sir, he *managed it*—managed it well—



Every farmer has need for belt power in some form, whether it be threshing, hay baling, grinding feed, cutting silage, husking and shelling corn (as here shown), sawing wood, etc.

managed it just like a big implement house way down in Dallas *ought* to be managed.

I was sitting out in the lobby of his office waiting to see him and this is what I overheard!

"You fellows are relying too much on the reputation of our stuff. Instead of going and doing some real sales work you are depending upon the prestige of the company to make sales for you.

"Oh yes! we've got a lot of prestige. No doubt about that. But the easiest way in the world to lose that prestige is to keep talking about it and trying to use it as a substitute for hard work.

"Prestige is a *result* of hard work—not a *substitute* for it!!

"We want men who will reflect credit on our name rather than men who fold their arms, stick out their chests and bask in the reflected glory of our product!"

—Then the door closed and that was all I heard, but it was enough to set me a-thinking.

And a little later on I went into his office and talked with this man—and if you happen to know him, you know that he's a man worth talking to. And in some way we got around to the same subject that he had been discussing with his salesmen.

And he said something about like this:

"We represent one of the oldest and best known lines in the world. We are doing a whale of a business. In fact we are doing such a business that new manufacturers coming into the industry don't seem to hurt us. Before I learned better I used to even laugh at new companies coming into the field. I always said to myself, 'You poor fish, what chance do you think you've got alongside of such folks as ourselves?'

"—But I don't say those things any more. In fact I rather welcome the newcomers and I'm inclined to give 'em a boost because usually I learn something from them—maybe not about tractors, but about human nature.

"No, I don't ridicule 'em any longer. I don't say they haven't got a chance. I don't say it, because I know that some of 'em HAVE got a chance. Some of 'em have got a *mighty good chance* and I'm going to tell you why:

"Yesterday one of our salesmen lost a sale to a tractor that is practically unknown. It was a good

tractor all right, but ours is equally as good—in fact I'm positive that it would have suited the farmer better.

"Now, mind you, I'm not *bellikin*. I didn't care so very much, in fact I was rather glad that it turned out as it did because this particular salesman and several of the others around here have been laying down on the job and it gave me an opportunity to give 'em a little common sense!!

"You see it's like this:

"—a salesman representing an unknown product—and I don't care whether that product happens to be a tractor or a sewing machine—a salesman representing an unknown product has got to make up in real personal effort and hard work what that product lacks in prestige. If he isn't a *go-getter* he's licked before he even gets started. It's a case of 'sink or swim'—and lots of 'em sink—but occasionally you'll find a fellow like this bird who beat us to it yesterday—a fellow who is going to swim in spite of all you do. You just naturally can't stop him from swimming and the chances are that if you watch him real close you'll learn a few new strokes yourself!

"And this kind of salesman schemes and plans. He knows he's up against it. He knows he's got to put it over single handed—maybe he hasn't even got a catalogue! But—he lays awake nights devising sales



The belt pulley of a tractor is just as important a part of the machines as the drawbar, if not more so.

propaganda and getting up a full head of steam. And then he puts on his grousers early in the A. M. and he goes out and does real work. He sticks to it day and night, he actually sweats with his customer—and *that's what turns the trick!*



Harvesting by means of a tractor.

"Now, on the other hand, you take a fellow from an organization like ours—when he feels a little lazy' he begins to reason to himself something about like this:

"I WORK for the Great EaterAcre Tractor Company. Their tractor is so good and so well known that it can't help but sell. I'm not feeling very good this morning—I don't feel like exerting myself. I'll call on a few customers all right, but I'll not take the trouble to explain the machine or what it will do. They can get all that dope out of the Beautiful EaterAcre Catalogue! The fact that the EaterAcre Tractor is built by the Mighty EaterAcre Tractor Company should be sufficient recommendation for anyone!

"Why, then, should I have to fight for business?"

"Yes, sir! that's what he says and that's the way he feels—I *know*, because I used to feel that way myself!

"And he doesn't fight for the business and what's more he doesn't get the business!

"As I said before, of course all the salesmen don't lay down this way, and even if they did, I 'spose we'd sell as much stuff as we can build for the next few years. Our business has a momentum. It has enough momentum to keep it going for a time even if the whole she-bang lays down on the job!

"But I'm not willing to let well enough alone. I don't figure it that way:

"A BUSINESS is like a bunch of fellows pushing a freight car—the idea being not only to keep the freight car moving but to get it moving faster and faster all the time. But one of the fellows gets tired and then he discovers that he can just run along without doing his share of the pushing—*It wouldn't take much headwork to discover that, would it?*—And then several other fellows discover the same thing, and then, later on, *one of 'em even wants to get on and ride!*

"—and the freight car may continue to move along, that is if it doesn't strike an up-grade, but when the car is turned over to the fresh crew of fellows at the next mile post instead of having gained speed it's pretty well slowed down!

"Yes, sir, and that's just what will happen to a business if the fellows depend on prestige to coast 'em along! But get me right on this, *it's not going to happen to my business!* and when the fresh crew of the next generation comes along to replace me and my men in the matter of pushing this business along they're going to find her running at top speed and with enough momentum to take it over the up-grades!—and, believe me, Brother, they'll find that they've got to do *some* pushing to keep up the pace!!

"Yes sir, pushing a business is like pushing a

freight car—and there's no place for the bird that wants to ride."

Prestige is a result of hard work—not a substitute for it!





## Sell McCormick and Deering Tillage Tools *Builders of Good Seed-Beds*

Farm seasons move on, and the farmer changes his demand for machines to fit the time, the crop, and the field, but his need for seed-bed tools pops up every now and then. He is likely to come to you now, and sure to come to you later, for **Good Tillage Tools**.

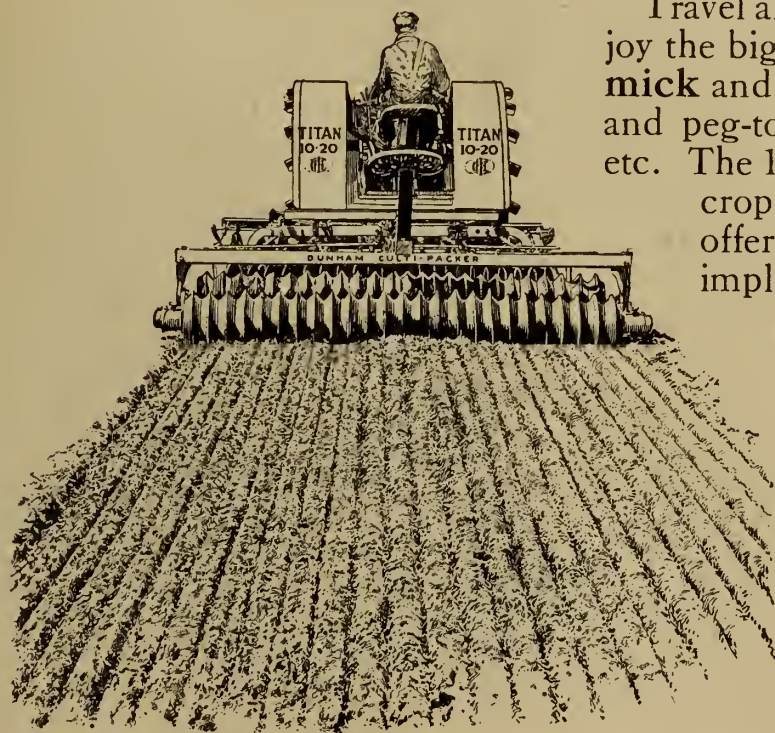

Travel along in the society of these agents who will enjoy the biggest tillage turnover this year. Sell **McCormick and Deering** tillage tools—disk harrows, spring and peg-tooth harrows, field cultivators, Culti-packers, etc. The 1920 International line of implements for laying crop foundation is the most complete we have ever offered. Farmers have come to know that these implements are thorough in their work, that they are not only efficient, but also very durable, being made of high-grade materials throughout. The name **McCormick, Deering and International** are guarantees of unquestioned worth.

Our campaign and co-operation will lead the seed-bed makers of 1920 to you for the best tillage implements. Get into communication with the branch house and build a record in sales of tillage implements.

### INTERNATIONAL HARVESTER COMPANY

OF CANADA LTD.

HAMILTON CANADA

WESTERN BRANCHES — BRANDON, WINNIPEG, MAN., CALGARY, EDMONTON, LETHBRIDGE, ALTA.,  
ESTEVAN, N. BATTLEFORD, REGINA, SASKATOON, YORKTON, SASK.

EASTERN BRANCHES — HAMILTON, LONDON, OTTAWA ONT., MONTREAL, QUEBEC, QUE., ST. JOHN, N.B.



# SHOP NOTES FOR THE GARAGE MAN

**I**N WELDING cast iron, such as automobile cylinders and machinery parts of similar character, it is necessary to preheat the part which is to be welded to a temperature which is slightly below a dull red heat, if there are no parts that will be injured by such heat. This heat should be applied gradually, and when the whole object has been sufficiently preheated, this welding can be done. There are two reasons for preheating. First, to save gas, and second, to relieve strains, due to uneven expansion and contraction of the part being welded. Great care should also be used to see that all castings cool slowly after welding, as many a good weld has been spoiled by too rapid cooling. A box of lime or ashes should be provided in which to bury the casting so it will cool slowly. An excellent work table and practical method of preheating a crank case by indirect method is shown at Fig. 1.

Where city gas of some kind, together with compressed air, are both obtainable in the shop, we recommend very highly a preheating blow pipe using this fuel. It makes an ideal outfit and in fact will be found just as efficient as the other preheaters shown, and will answer any and all purposes to which the oil burning preheaters might be applied. Of course, where fuel gas and air are not obtainable in the shop, the writer recommends the oil burning outfit, although they are slightly higher in price. But, as stated, where the shop is so situated as to be fortunate enough to have both compressed air and fuel gas of some kind the gas preheating torch will be found to be very satisfactory, as the first cost, and also the cost of maintenance, is low. The furnace or muffle is then built of fire brick to a suitable size for the particular part we are about to weld. A removable cover is used of asbestos board or sheet metal.

After the welding has been done, the object should be heated again in a similar manner as the preheating was done and then allowed to cool off slowly in the muffle. This is necessary to prevent cracking due to the local expansion and contraction, caused by the local heat of the welding flame. This method is also useful in obtaining a softness of the material in the weld. This method of handling welding of cast iron will prove a saving of from 30 to 50 per cent. of the cost of gases used for welding.

There is nothing particularly difficult in the handling of the welding flame in connection with welding cast iron, but it should be borne in mind in welding of heavy sections, that the fractured portions should be tapered out in order that the welding can be commenced at the centre of the section, building up as the welding proceeds. A flux is necessary for use in welding cast iron and will be found to make the metal flow readily and at the same time, flux out the sand, dirt, grease, etc. Be sure that the sides of the fracture are in molten condition before filling material is added. Large objects are handled in a different manner, the indirect heating being better adapted for metals such as aluminum. This method is shown in Fig. 1 B.

## Aluminum

**T**HE welding of aluminum requires considerable skill and experience before successful work can be expected on intricate parts. The manner of making the weld is slightly different from that used with welding of cast iron, due to the fact that when aluminum is heated, an oxide film is formed, which prevents the metal running together and forming a suitable weld. To overcome this, the aluminum filling rods must be inserted into the molten aluminum, which is being

## Method to be Used in Welding Different Metals

By F. H. SWEET

welded, and moved about rapidly, something similar to puddling, in order to break up this oxide film and allow the aluminum to run together. A flux has also proven of advantage in this connection, where before, practically

which is being held in shape by the fire clay form. Now the extra metal can be added from the filling rod and stirred or puddled with this rod to break the oxide film which forms when aluminum is melted. A flux has been

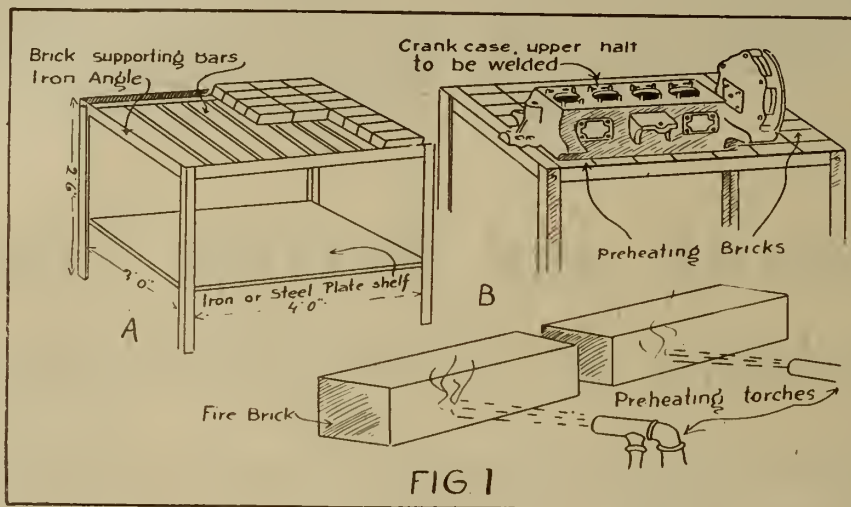

all of this work was done without the use of a flux.

A larger tip is necessary for welding a section of aluminum than would be required for the same section of steel or cast iron. This is due to the fact that aluminum conducts heat away very rapidly. With the proper size tip in use, it is necessary to melt a considerable portion of aluminum,

provided for use in this connection and will be found very valuable for breaking up this film. In fact, by using this flux, bosses can readily be built up at any desired point. This is something that could not be done before a flux for welding aluminum came into general use.

All precautions should be taken to have the work securely fastened or

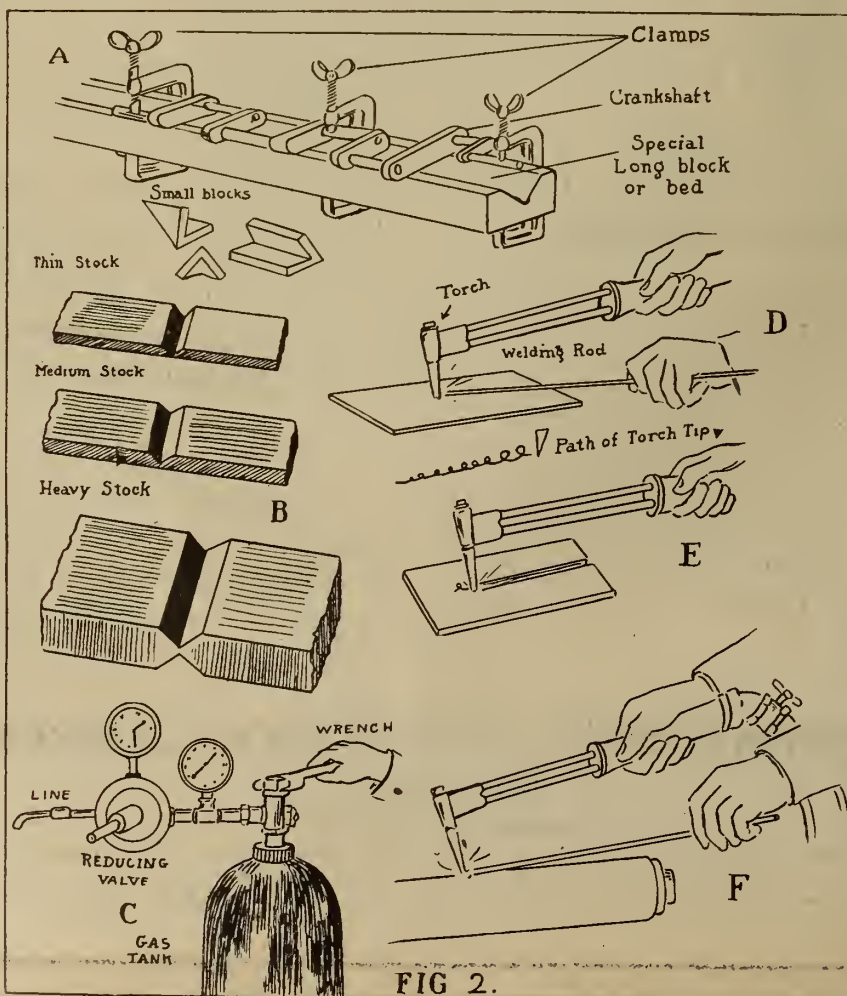

harnessed, for instance, when welding a hole in the side of a crank case, it is customary to clamp a shaft, which approximates the size of the bearings (plus, of course, the thickness of the cast metal bearings, which would melt out when preheating,) into the crank case bearing supports, in order to insure perfect alignment of the bearings. Angle irons are bolted to the flanges where connection is made to the other half of the crank case in order to insure perfect alignment of this part.

It is good practice to place a sheet of paper on the inside of the case next to the crack to be welded. This paper prevents the fire clay from getting into the crack. Upon this is placed fire clay in plastic condition which is held in place by means of asbestos fibre. This makes a light backing or mould for the case and can be easily handled without fear of the mould or core being so heavy as to break down the case when heated for welding. This mould should be large enough to cover sufficient area around the crack so that the aluminum will not break down.

Aluminum parts must always be preheated and handled in a similar manner as automobile cylinders, as outlined before, with the exception that aluminum, of course, should not be heated to such a high temperature, on account of the fact that within 50 degrees C. of the melting point, the metal is very brittle and without strength. It is customary to heat up these cases thoroughly until they will melt half and half solder in wire form. This temperature is about right to prevent cracking occurring on account of expansion and contraction, and at the same time the aluminum will possess sufficient strength so that with ordinary handling no trouble is experienced with alignment or failure of the part.

## Malleable Iron

**P**ARTS of malleable iron are handled in much the same manner as cast iron pieces in preparation for welding. It is customary to reinforce the malleable iron weld as much as possible by building up the section at the fracture. The filling material used is usually nickel steel in the bottom of the weld, finishing the top surface with cast iron rod. The latter runs better and makes a smoother finish.

In some instances you may find that the fracture will be through a tapped opening, in which case it will be necessary to cape this portion out entirely, making a much larger opening than the hole itself and then filling this with cast iron, using the same precaution as in welding cast iron to have this portion soft. Wherever the union is made between filling material used and the malleable iron, you will find this so hard that it will be impossible to drill or machine in any way except by grinding.

In some cases, in making repairs on malleable iron parts, it is even necessary to strap these parts by means of wrought iron or steel straps welded to the body of the casting. In any event, bear in mind that the heat necessary to melt the malleable iron will destroy the properties of the malleable iron, which were put into the part when annealed in the furnace. Consequently it is necessary to use a stronger filling rod and increase the section.

## Brass and Bronze

**T**HE preparation of brass and bronze castings for welding is similar to that for gray iron castings. The fracture must be capped out so that the welding can start at the centre, the groove being filled with metal melted from filling rod. The filling rod should be of approximately the same mixture

Continued on page 20



# Two Cockshutt Leaders

*They sell. They satisfy. They open the way for the sale of other Quality Implements in the complete Cockshutt Line. They're profitable.*

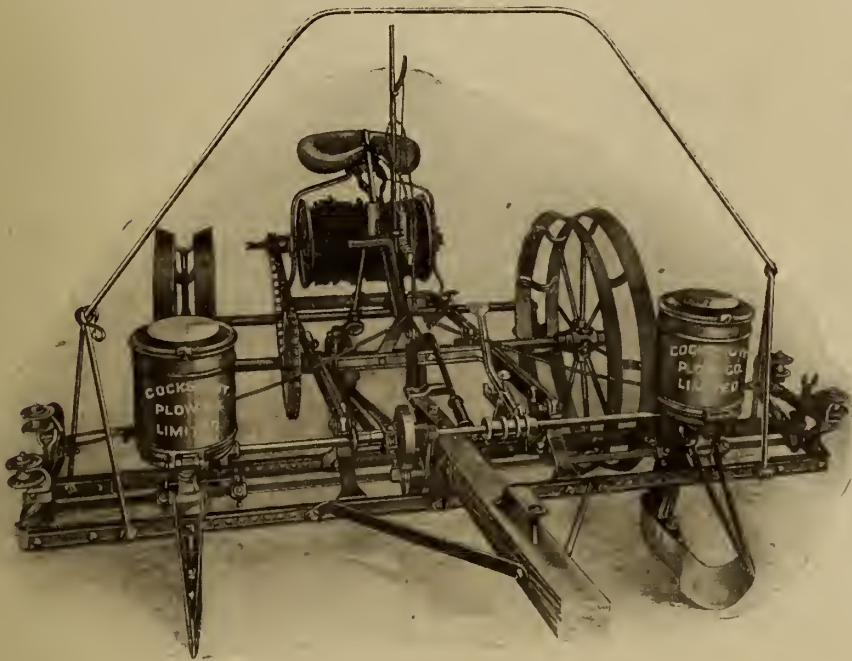

No. 3 CORN PLANTER

Like all other Cockshutt Implements, these two "Leaders" clearly show the handiwork of the master builder. They're designed and built to do their work RIGHT, and do it year after year. They always give a good account of themselves in the field.

## Cockshutt No. 3 Corn Planter

Adjustable for work in rows 28 in. to 44 in. apart. Can be used for checking corn in hills or drilling it in rows. Fertilizer attachment supplied when wanted. It's a variable Drop Planter. Either two, three or four kernels can be dropped. Quantity can be changed by simple foot lever. Rigid frame ensures uniform depth of planting. There are many features about this Planter that appeal to corn growers and its good reputation carries a lot of weight with the prospective buyer.

## Cockshutt No. 5 Cultivator

It's a real time-saver—cultivates two rows at a time at all widths from 28 in. to 44 in. Unequaled for strength—built throughout of steel—it embodies the latest and best improvements in cultivators. Five handy levers make all adjustments easily and quickly. Full set of teeth, thistle blades and hillers with each cultivator. As a time and labor-saver the Cockshutt No. 5 Cultivator makes a strong appeal to the farmer. As a money-making proposition for the dealer it is in a class by itself.

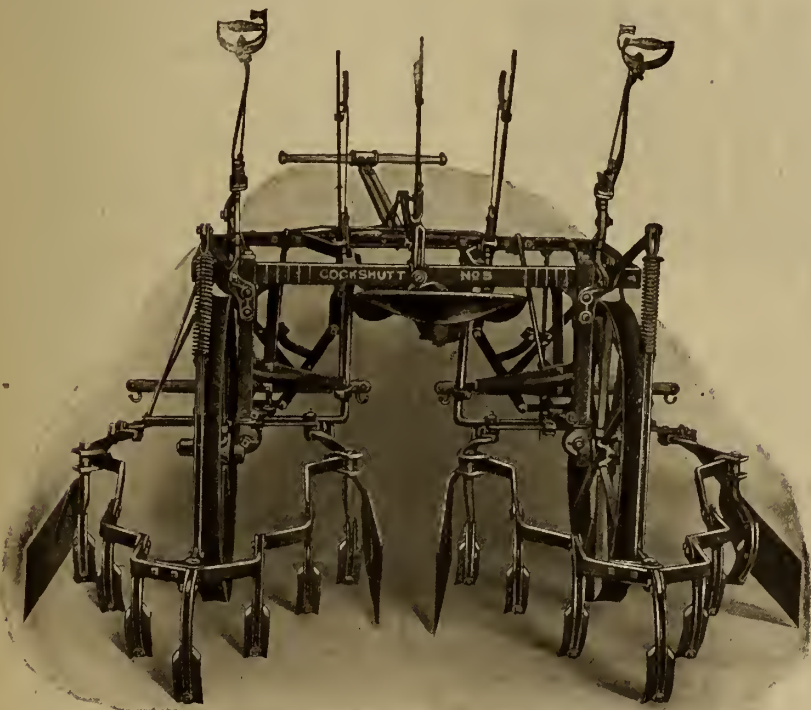

COCKSHUTT No. 5 CULTIVATOR

Send for our dealer proposition. It's interesting. To the dealer who realizes the value of a complete line of implements, is a money-maker. Cockshutt Implements, quality built, backed by steady, consistent advertising, have built up success for hundreds of dealers.

**Cockshutt Plow Co.**  
Limited  
BRANTFORD, ONT.

*Sold in Eastern Ontario,  
Quebec and Maritime  
Provinces by*

**The Frost & Wood Co.**  
Limited  
Montreal SMITH'S FALLS St. John



# Northern Electric POWER and LIGHT

## A Complete Line of Electric Farm Plants and Accessories

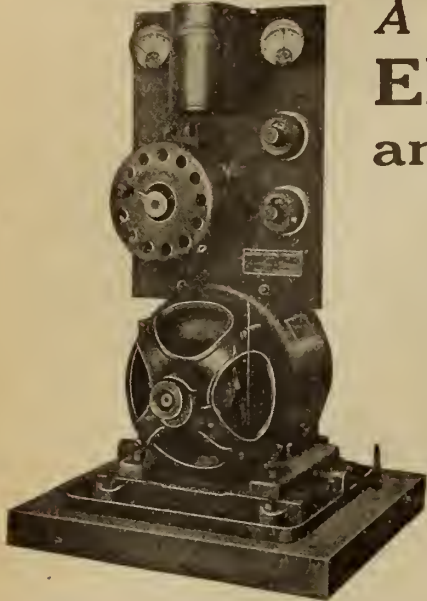

Belt-connected Plant — operates from any good engine

Belt Connected Plants  
Direct Connected Plants  
Water Systems  
Portable Motors  
Farm Accessories  
Wires and Supplies

This line will make you the Electrical Headquarters of your District.

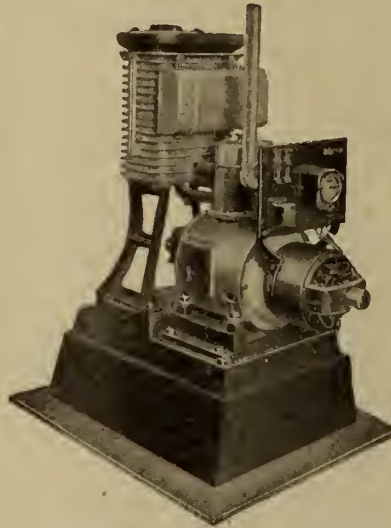

Direct Connected Utility Plant  
¾ K.W.—32 Volt



Automatic Water System, showing Tank, Pump and Motor. Capacities 100 to 1400 gals. per hour

¶ With the plant you can usually sell a Water System, while limitless follow-up sales possibilities are yours with Utility Motors, Electric Churns, Vacuum Cleaners, Washing Machines, Dishwashers, Irons, Toasters, Percolators, Wiring Devices of all kinds, Fixtures, etc.

Write Our Nearest House Now

Be the Farm Electrifier of Your District



Titan Storage Battery, 16 cells supplied with each plant. 110 or 200 Ampere Hours

## Northern Electric Company LIMITED

MONTREAL

OTTAWA  
HALIFAX

LONDON  
TORONTO

WINNIPEG  
QUEBEC

EDMONTON  
REGINA

CALGARY

VANCOUVER

### METHODS TO BE USED IN WELDING DIFFERENT METALS

Continued from page 18

as the part to be welded. Brass should never be used as filling material for bronze castings, if a strong weld is expected. Powdered borax or boric acid may be used as a flux. A mixture of ½ borax and ½ boric acid gives good results. In welding brass or bronze the work is carried out as for welding cast iron. The metal surrounding the groove is melted and the filling material added, drop by drop, as it is melted from the rod. Be sure the metal of the casting is in a molten condition, otherwise an imperfect weld will result. Brass welds can be easily spoiled by burning the zinc out of the composition. Care should be taken not to heat beyond the melting point. Flux should be used freely. If the welded portion has been burned, it will be exceedingly porous. Various useful suggestions are shown at Fig. 2.

Be sure the welding flame is neutral, and that the part to be welded is set up properly. A poor set may spoil the best weld for practical use.

### HOW TO DRILL DIFFERENT MATERIALS

WHEN drilling, turning or reaming malleable iron or aluminum to get best results kerosene should be used. Hard steel should be drilled with turpentine instead of oil as the turpentine will make drilling easy when the metal cannot be touched with oil. Glass may be drilled with a common drill by using a mixture of camphor and turpentine. When the point of the drill is coming through the hole should be worked with a reamed or the end of a three cornered file having edges ground sharp. A scraping motion should be applied rather than a reaming. Of course great care should be exercised so that the glass isn't cracked or pieces flaked off while finishing. The mixture of turpentine and camphor should be used freely both while drilling and scraping. This mixture can be used with efficient results to drill exceptionally hard cast iron and even tempered steel.

### MOTOR SHOW AT KINGSTON

AT a very enthusiastic meeting of the automobile dealers held in the offices of the Board of Trade, Kingston, Ontario, a local Automobile Dealers' Association was formed, and every dealer in the City of Kingston was enrolled as a member. The first big venture of the newly formed organization is to be a Motor Show, and the local armories has been obtained for the purpose. The show will be staged from Tuesday evening, April 27th, to Saturday evening, May 1st, and the services of Mr. T. C. Kirby were secured as show manager.

It was decided to donate half of the net profits of the show to the Queen's University Hospital, and the remainder to the funds of the local association.

T. C. Kirby, who has a most successful record as a show manager in Eastern Canada is preparing an elaborate floor plan, and the preliminary organizing details are now going on full steam ahead.

Application for space already to hand, total 75 per cent. of the net floor space, and among the exhibitors already having reserved space, a total of twenty-two passenger cars, and several different makes of trucks and tractors will be shown. Many of the makes of cars are entirely new to these parts.

Many special attractions are being arranged, and prospects of Kingston's first Annual Motor Show are exceedingly bright.

NANTON.—A new implement store has been opened by Messrs. Harvey and Cook.



SAYS THE MASTER MECHANIC: The Greb Automatic Grip Puller is a One-Man Puller—Quick-acting, strong and simple in the extreme. May be locked in any desired position. A combination of two or three arms. Heavy Duty Size capacity 1" to 1 1/2". Junior Size capacity 1/2" to 1". Two sets of jaws furnished with each size.

TEN DAYS' TRIAL.—If your dealer or jobber does not have them we will send you one. Try it ten days. If not satisfactory, return to us and we will refund your money. We also make the GREB RIM TOOL.

THE GREB COMPANY, 319 State St., BOSTON

### Broughton's Blowout Boots Bind Bad Breaks and Bruises Best

Made of Steel.  
Keep them on hand for any automobile tire weakness.

At Your Dealer, or

THE GEO. H. BROUGHTON CO., Mfrs.  
122 Wellington Street West, Toronto, Ontario



### BEAVER TRUCK IN OTTAWA

THE City of Ottawa has seen within the last few days, the appearance of a new motor truck. It is the Beaver Motor Truck manufactured by the Beaver Truck Builders Limited, of Hamilton, Ont. The model which was seen in Ottawa is one of the largest made by the Hamilton firm, and it was demonstrated by the Emerson Motor Sales. The agency for these big motor trucks was awarded to the Ottawa Car Garage, which is one of the best known of its kind in the Capital.

WANTED—CLERICAL POSITION, PREFERABLY Private Secretary, by young married man, Canadian, experienced accountant, shorthand writer and typist. Have completed the Gas Engines Course of the International Correspondence Schools. Best references. Address Box 566, Lethbridge, Alberta.



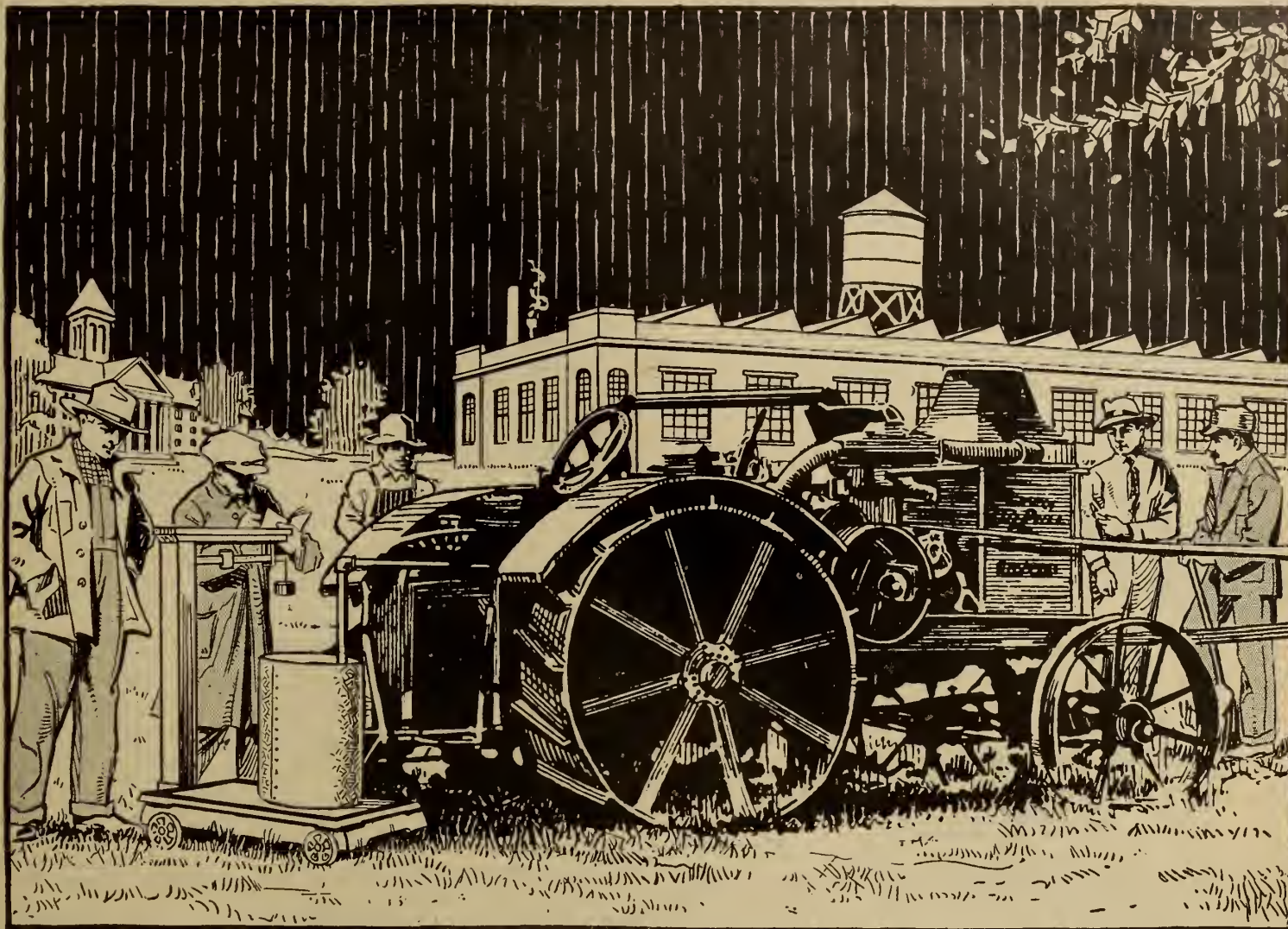

## OilPull again breaks World Record

FOR eight years the world's record for fuel economy in tractor motors stood at .7 pounds of kerosene per horse-power hour. It was made at the Winnipeg Tractor Contest in 1912 by the Rumely OilPull tractor.

In January, 1920, this record was broken at the Tractor Fuel Economy Tests held at Ohio State University at Columbus—and it was broken by another OilPull tractor.

The OilPull's new figure of .606 pounds of kerosene per horse-power hour not only exceeds every fuel economy figure ever made by kerosene or gasoline burning tractor motors, but lowers the old OilPull record over 13%.

Again it is a significant fact that this same tractor then went on the maximum load test and developed a reserve power of 40 $\frac{3}{4}$ % more than its rating.

In addition to all this the same tractor then went through the variable load test and emerged triumphantly with a grade of good plus for close governing.

But even more significant is the economy, dependability and durability of the OilPull as proved by its unequaled record of performance in the hands of thousands of owners since the birth of the tractor industry.

Your prospective tractor buyers want proved economy, proved power and proved performance. No tractor shows a better proved record than the OilPull in all its four sizes, 12-20, 16-30, 20-40 and 30-60 H. P.—that's why most of the 1920 OilPull output is already sold—that's why you should write *today* if you wish to represent the OilPull in your locality.

ADVANCE-RUMELY THRESHER CO., Inc.

L.a Porte, Indiana

Calgary, Alta. 48 Abell Street, Toronto, Ont. Regina, Sask.  
Saskatoon, Sask. Winnipeg, Man.

# ADVANCE-RUMELY

RUMELY  
**OILPULL**  
TRACTOR  
LA PORTE IND.





Grinder with Elevator and Bagger

The Famous  
"VESSOT"  
Grinding  
Plate

## "VESSOT" FEED GRINDER

POPULAR WITH DEALERS AND USERS  
EVERYWHERE

Dealers make a good commission on "Vessot" Grinders and they are never bothered with complaints, the "Vessot's" good service is consistent and reliable.

We challenge the world to produce plates that will grind and wear with genuine "Vessot."

We make nine different sizes of grinders, 6½-in., 8-in., 9-in., 9¼-in., 10½-in., 11-in. B Farm Type, and 11-in., 13-in. and 15-in. Mill Type.

Write the nearest branch of the International Harvester Company for Agency proposition. It's well worth while.



INVENTORS AND MANUFACTURERS

### S. Vessot & Co., Joliette, Quebec

Sold exclusively in Canada by

International Harvester Co. of Canada, Limited

Branches: Calgary, Edmonton, Lethbridge, North Battleford, Regina, Saskatoon, Yorkton, Brandon, Winnipeg, London, Hamilton, Ottawa, Montreal, Quebec, St. John.

## NEWS — OF THE TRADE FOR THE TRADE

### ONTARIO

**WINDSOR.**—The Hup Motor Car Company, it is announced, will extend their Canadian plant here.

**TORONTO.**—A motorbus service between Toronto and Hamilton will be established early in April.

**WINDSOR.**—The Paige-Detroit Motor Car Company, has secured a site here for a Canadian plant.

**OTTAWA.**—A new garage, to be known as Stanford's Garage, has been opened at 1023 Wellington Street.

**TORONTO.**—The Scofield Tractor Corporation, Ltd, has been incorporated with a capital stock of \$1,000,000.

**LONDON.**—A new motor truck equipped with a special pressure pump will be purchased at a cost of \$15,000.

**CHATHAM.**—Brisco's wholesale Accessories, Limited, has been incorporated with a capitalization of \$10,000.

**GRIMSBY.**—Announcement is made of the incorporation of the County Motors Limited, with a capital of \$40,000.

**WIARTON.**—G. F. Bryson has taken over the auto tire vulcanizing business formerly conducted by O. E. Langford.

**TORONTO.**—The Lexington Motor Sales, Ltd., has been appointed distributor for the Canadian made Veteran truck.

**BELLEVILLE.**—The Weed Harvester Machine Company, Limited, has been incorporated with a capital stock of \$50,000.

**TORONTO.**—The directors of the Willys-Overland Company are considering increasing the capitalization of the company.

**PETERBORO.**—The Canadian General Electric Co., is contemplating an extension to the Peterboro plant which will cost \$1,000,000.

**TORONTO.**—The Tiger Tire and Rubber Company has been incorporated with a capital of \$2,000,000, divided into 65,000 shares.

**TORONTO.**—Donald McQuarrie, formerly with Overland Sales Ltd., has joined forces with the Lexington Motor Sales Ltd., 589-591 Yonge St.

**TILLSONBURG.**—C. H. Fisher has purchased the implement business conducted by W. E. Moore. Mr. Moore is going into the insurance business.

**RENFREW.**—The Renfrew Machinery Co. announce the appointment of W. F. Webster, formerly with the La Crosse Tractor Co., as their tractor salesman in Western Ontario.

**LONDON.**—The R. G. Edgecombe Company, Wholesale Automobile Accessories and Carriage Hardware Limited, has been incorporated at \$100,000 divided into 1,000 shares of \$100 each.

**TORONTO.**—The Ontario Motor League will engage uniformed scouts on the Toronto-Hamilton Highway this season to assist in regulating traffic and help league members in case of breakdowns.

**LONDON.**—H. M. Gousha of Chicago visiting here recently announced that the route between Niagara Falls, Hamilton, London and Sarnia has been definitely adopted for the Roosevelt Memorial Highway.

**BRANTFORD.**—Partnership has been dissolved between Amos A. Lemon and J. A. Lane in the Motor Transfer Company. The business will be carried on by John A. Lane, who is assuming all liabilities of the partnership.

**BRANTFORD.**—The roads and bridges committee of the County Council have decided to spend \$26,000 on machinery for road making. The

purchases will consist of a truck, two tractors, oil tanks, scrapers and small tools.

**TORONTO.**—Messrs. Bradley and Love, Limited, have been appointed Ford dealers in Toronto. They are opening a new sales and service station at Woodbine Avenue and Queen Street East, which will have a capacity of 13,000 sq. feet.

**OTTAWA.**—J. A. Pinard, M.P. for East Ottawa, enquired in the Legislature recently how many autos were owned by the Government, how many were used by Ministers of the Crown and how many chauffeurs were employed by the Government.

**TORONTO.**—The Packard Motor Car Company of Detroit advises its distributors, the Packard-Ontario Motor Car Company, Limited, Toronto, that it will accept Canadian funds at par on the sale of Packard cars and will invest such funds in Canada.

**CHATHAM.**—The Chatham Motor Show was held from March 17 to 20. There was a large number of exhibits. M. M. Maxwell, manager of the Chamber of Commerce, and Walter Fussey, president of the Chatham Auto Dealers' Association, gave the opening addresses.

**ST. THOMAS.**—The Elgin Motor Club at a meeting held in the City Hall recently, discussed the provincial highway and Port Stanley road matters. The officers elected for 1920 are as follows: Hon. President, P. G. Cameron, of Dutton; President, M. B. Johnson; Vice-President, W. C. Forbes; Secretary-Treasurer, G. A. Ferguson; Auditor, W. R. Coulter.

### MANITOBA

**PILOT MOUND.**—C. B. Cohoe has purchased the Pilot Mound Garage and Machine Shop.

**HIGH BLUFF.**—Messrs. Jackson and Wilson have opened a garage and will do all kinds of repairs.

**WINNIPEG.**—The wholesale and retail dealers announce a 20 per cent. increase in automobile tires.

**WINNIPEG.**—The Burd Ring Sales Co., 322 McIntyre Block, have been appointed Dominion of Canada distributors for the Violet-Ray lens.

**WINNIPEG.**—Martin Engers is the Western representative of the Dominion Battery Co. This concern recently opened a warehouse in Winnipeg.

**FOXWARREN.**—S. J. Fallon has purchased the garage business of Mr. Laycock. He will handle Buick cars and Fairbanks-Morse Lighting Plants.

**BRANDON.**—A single day automobile show was held recently in the Winter Fair Arena when every model of every car sold in Brandon was on exhibition. Accessories and batteries were also displayed and an address "Automobile Users and Good Roads" was given by D. D. Bennett of the Western Branch of Chevrolet Motor Co.

### SASKATCHEWAN

**MOOSE JAW.**—Hugh Rorison has the agency for the John Deere line.

**MOOSOMIN.**—The Moosomin Tire Repair Co., a new concern, has just opened up.

**INDIAN HEAD.**—Messrs. Blair and McLean have opened an implement business here.

**MOOSE JAW.**—A tractor business has been opened here by C. Waring and Company.

**REGINA.**—W. H. Harris and W. J. Ralph have purchased the City Garage on the corner of Albert and Victoria streets. They will handle the Chalmers and Maxwell cars.

## BIRDSSELL CLOVER HULLERS

Best for Threshing,  
Hulling and  
Cleaning

Little Red or Common Clover Seed  
Big English or Mammoth Clover Seed  
Alsike Clover Seed  
Sweet Clover Seed



THREE SIZES FOR CANADA

No.	Cylinders	Size	Capacity	Power Required
No. 2	27"	x 32"	3 to 5 bushels per hour,	6 to 8 H. P.
No. 1	30"	x 36"	5 to 7 bushels per hour,	8 to 10 H. P.
No. 8	40"	x 52"	7 to 10 bushels per hour,	10 to 12 H. P.

WE HAVE A SIZE TO SUIT EVERY NEED

## ANN ARBOR HAY PRESSES

If in the market for a Hay Baler we can furnish in any size to meet your requirements. Write us or call and see us while in the city.

### Birdsell Manufacturing Co.

Foot of George Street  
Toronto, Canada



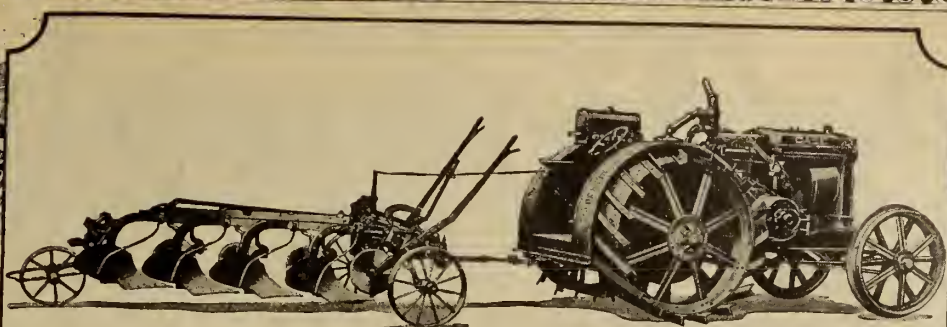

Case 22-40 Kerosene Tractor pulling 4-bottom Grand Detour Plow

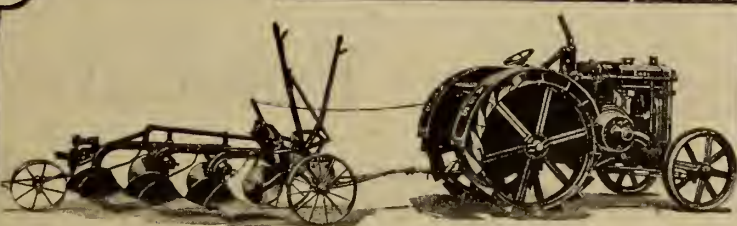

Case 15-27 Kerosene Tractor pulling 3-bottom Grand Detour Plow



Case 10-18 Kerosene Tractor pulling 2-bottom Grand Detour Plow

## From the Same Maker— Through the Same Dealer— To the Same Farm!

**C**ASE Kerosene Tractors and Grand Detour Plows, designed to fit each other, should be logically sold together and used together. Every buyer of one is a prospect for the other.

Case Kerosene Tractors, standardized in design and simplicity of adjustment and operation, are built with respective ratings of 10-18, 15-27 and 22-40 h.p., for farms of any size.

Grand Detour Plows are built with two, three, four, five and six bottoms. Different shapes of bottoms are available to meet the soil conditions in different localities.

The J. I. Case Threshing Machine Company also builds the following great line of machinery, best drawn or driven by the proper size of Case Kerosene or Steam Tractors:

- Grand Detour Double Disc Harrows—5 sizes
- Threshing Machines—six sizes
- Hay Balers—two sizes
- Road Graders—three sizes
- Rock Crushers—two sizes

Case Steam Tractors are built in eight sizes, and Case Steam Road Rollers in two sizes. Special descriptive catalogue free to any dealer on request.



Look for the  
EAGLE  
Our Trade Mark

**J. I. CASE THRESHING MACHINE CO., Inc.**

Dept. O-4, 345-9 Dufferin Street, Toronto, Ont.

*Making Superior Farm Machinery Since 1842*

**CASE**  
TRADE MARKS REG. U.S. PAT. OFF. AND IN FOREIGN COUNTRIES.  
**POWER FARMING**  
**MACHINERY**

To avoid confusion, the J. I. CASE THRESHING MACHINE COMPANY desires to have it known that it is not now and never has been interested in, or in any way connected or affiliated with the J. I. Case Plow Works, or the Wallis Tractor Company, or the J. I. Case Plow Works Co.

**NOTE:**  
We want the public to know that our plows and harrows are NOT the Case plows and harrows made by the J. I. Case Plow Works Co.



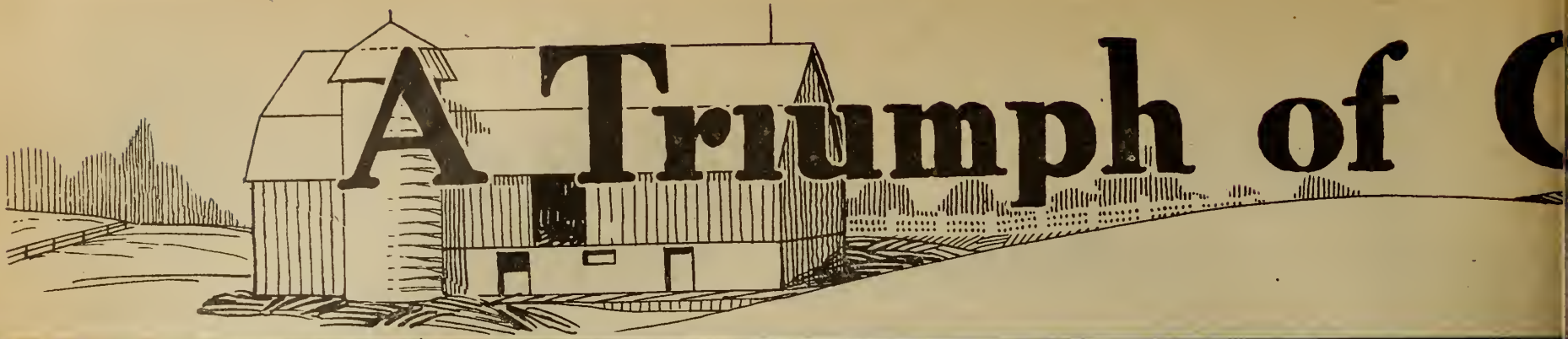

## What Some American Agents and Dealers Say About the Renfrew Cream Separator

Ontario, Wis., May 21, 1919.

Mr. Neils Anderson,  
Elgin, Ill.

Dear Friend Anderson—I had an occasion here to have some skimmed milk tested for butter-fat, skimmed by the Renfrew, and the result was "only a trace," less than one-hundredth of one per cent.

The buttermaker was very much interested in the separator, and asked me what it was. I told him. Please send the buttermaker a few catalogues. His name is H. A. Budda, Ontario, Wis. Respectfully,

A. F. STERLING,  
"Acme Block Man."

Gays Mills, Wis., August 15, 1919.

R. N. Jacobi Co.,  
Milwaukee, Wis.

Gentlemen—I wish to say in regard to the Renfrew Cream Separators, we sold some of these machines about two years ago, to try them out among our customers, and then turned the agency over to the Barlow Auto Co., here, not having time to devote to the sale of them.

All the Renfrew Separators sold have given the best of satisfaction and we are now handling cream from these Separators that runs and has run universally from 30 to 35 per cent. This we consider decidedly above the average. On one machine that we took particular notice of all summer the test kept above 32 per cent—a very remarkable record.

We have not had a single complaint of any kind on any Renfrew machine, and believe them to be easily cared for and sanitary. Respectfully yours,

S. C. GEORGE,  
Butter Maker and Cream Buyer.

Chaseburg, Wis., 8/19, 1919.

R. N. Jacobi,  
Milwaukee, Wis.

Gentlemen—I sold one of your Renfrew Cream Separators bought from La Crosse Plow Co. four years ago. Have never heard from the farmer except for more business since that time. Now that this separator is represented by a live concern I have again taken the agency from your Mr. Anderson and will handle your machine with the De Laval and Primrose Separators. Making this connection shows you what I think of your special feature.

Sincerely yours, PHILIP BOUFFLEUR,

Fall Creek, Wis., Sept. 19, 1919.

R. N. Jacobi Co.,  
Renfrew Machinery Co. Distributors,  
Milwaukee, Wis.

Gentlemen—We hereby notify you that we want to continue the Renfrew Cream Separator Agency here.

We formerly bought them from the La Crosse Plow Co., and have had some of your machines out for seven years, that have never required repairs and that are skimming to-day down to .01 per cent., just as close as when they started. We have never had any dissatisfaction and know there is no better separator made. We therefore wish to continue as your agents here.

Kindly inform us as to your new selling plan. Yours truly,  
STELTER AUTO CO.,  
T. M. S.

## American Farmers and Cream Separators to Arrive Dealers Make

In the most densely populated agricultural districts of the United States the Renfrew Cream Separator is selling at a rapid rate, in spite of direct and close opposition from the most famous American makers of cream separators!

We are building up a big business with our Canadian-made separator "right in their own back yard."

Isn't that an excellent indication of the value of the Renfrew? Shrewd buyers, American farmers and dairymen, after closely inspecting *all* makes of separators, are deciding on the Renfrew.

Read the letters in the panels of this advertisement and see what some of our agents over there have to say about their successes. These letters speak for themselves, and show the enthusiasm with which our representatives in the States are working.

One and all they agree that it is *THE BEST* separator on the market. They are selling great numbers of Renfrews, and, of course, their PROFITS ARE VERY HANDSOME.

The great feature of the Renfrew which will appeal to any farmer or dairyman, is its ability to skim close.

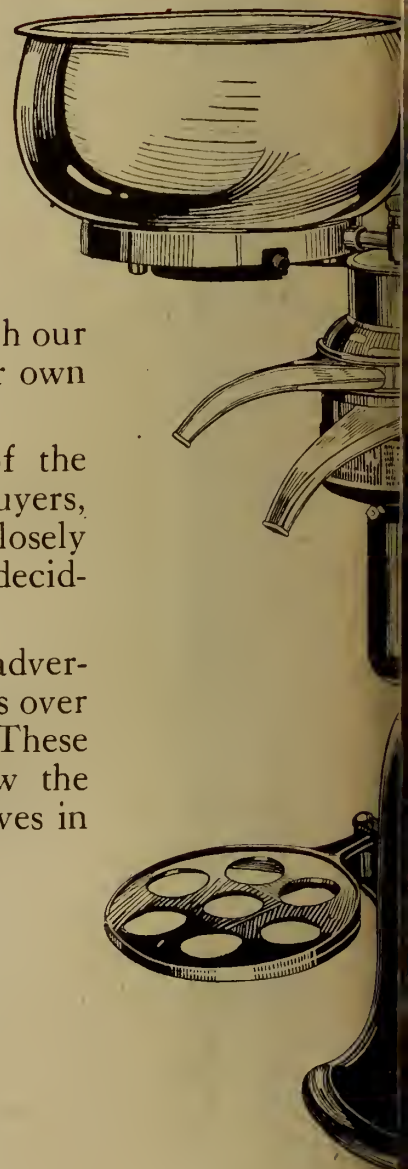

# Renfrew Cream

THE RENFREW MACHINERY CO.

Head Office and Works: RENFREW, ONT.





## Airymen Prefer Renfrew American-Made Separators Big Profits

It actually gets 99.99 per cent. of the butter fat. That has been proved by Government tests. To the farmer this close skimming means bigger profits. To the agent it means easier sales.

The Renfrew is the separator *with the interchangeable capacity*. The 450-pound bowl can be replaced quite simply by a 1,000-pound capacity bowl, without taxing the strength of the machine. All Renfrew machines have the same sized frames.

Users of the Renfrew get firmer, better butter owing to the exclusive wide open bowl with the curved wings.

The Renfrew is easily cleaned, very sanitary, runs smoothly and easily, lives long, and is self-oiling.

It is a separator with many fine

### EXCLUSIVE SELLING POINTS

We give our agents and representatives every support possible. Our Dominion-wide, extensive advertising campaign paves the way to many sales.

If your territory has not been seized by some enterprising agent, write us at once for our literature and selling proposition.

And don't forget that the Renfrew Cream Separator was invented by a Canadian, is built by Canadian workmen and is manufactured with Canadian capital. It is a *triumph of Canadian skill*.

# Renfrew Separator

RENFREW COMPANY, LIMITED

Offices: Montreal, P. Q., Sussex, N. B., Milwaukee, U. S. A.

## More Unsolicited Compliments from the States

Republic, Missouri, August 26, 1919.

Renfrew Machinery Co.,  
Milwaukee, Wis.

Gentlemen—I am not a professional salesman, but I have just sold a Renfrew Separator, or rather the machine sold itself in competition with both the . . . and . . . which as you know are two of the standard makes and widely advertised for their efficiency.

A certain lady tried both these machines in competition with the Renfrew. She returned both and kept the Renfrew — paid me for it to-day.

Could you loan, or sell me, a cut like the one you use on your envelopes, for the purpose of advertising your separator at a coming stock show?

Very respectfully,  
O. L. FULBRIGHT.

New Lisbon, Wis., Sept. 29, 1919.

R. N. Jacobi Co.,  
Milwaukee, Wis.

Gentlemen—I have received the last four Renfrew Cream Separators that I ordered a short time ago. Will you send me at once a No. 6 cream screw and a half-dozen rubber rings, No. 6 and No. 8. I have sold Renfrew Cream Separators for six years now and it seems rubber rings are the only parts we are ever called on to supply to Renfrew owners.

Just last week I had a talk with three of the farmers I sold your machines to over six years ago, and they volunteered the statements that their machines were running just as easy and skimming just as close as when they bought six years ago, and their opinion was that they couldn't be worn out, as they had not spent a cent on them except a few rubber rings in all that time.

I first bought Renfrew Separators from the La Crosse Plow Co., of La Crosse, and then from the Acme Harvest Machine Co., and then as you know I have sold ten or twelve machines since you began your campaign for better and more enthusiastic support to the dealer.

I want you to know that I am with you, and of course selling Renfrews exclusively. Sincerely yours,

OTTO EBERHART.

Adrian, Missouri, Oct. 18, 1919.

P. J. Downes Co.

Gentlemen—Will say we formerly sold the . . . Separator, but after a demonstration of the Renfrew decided it was the most up-to-date Separator on the market.

We have sold over 200 of these separators and have our First dissatisfied customer to find. Resp.,

J. W. PACKER & SONS.

Rewey, Wis., April 11th, 1919.

R. N. Jacobi Co.,  
Milwaukee, Wis.

Gentlemen—

Will say I formerly sold the . . . Machines, and changed to the Renfrew on account of the general absolute satisfaction that this gives to the user, and I can make a better profit and at the same time give my customer a better machine for less money. I am now selling Renfrew Cream Separators exclusively.

J. H. LEYSON.



# Automotive Accessories and Implement Equipment

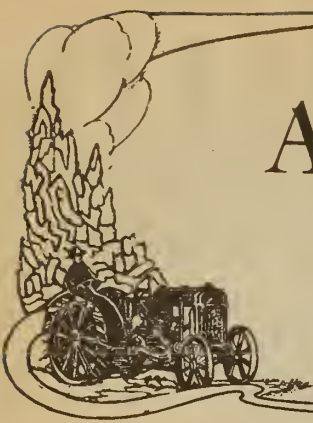

## ELECTRIC AUTOMOBILE-ENGINE HEATER

TO KEEP an automobile engine warm during normal winter weather as the car stands in the garage, an electric automobile-engine heater has been recently placed on the market by the Westinghouse Electric & Manufacturing Company of East Pittsburg, Pa.

By the use of this method, the makers say, the heat is concentrated at the engine and carburetor, where it will do the most good. Thus, on cold mornings, no difficulty will be experienced in starting the engine, as the temperature of the latter will always be well above that of the outside air.

The appliance is ruggedly built and practically indestructible. The heating unit is protected by a strong perforated sheet-metal guard entirely surrounding the heater. A rigid metal hook allows the heater to be hung anywhere under the hood. The flexible cord is long and the plug can be attached to any lamp socket. Altogether, it is well-built with no delicate parts to get out of order:

The power consumption is only 100 watts. The initial cost and the expense while in use are both small. The cost of operating is less than one cent an hour (based on power rate of 10 cents kwh).

## AUTOMATIC BATTERY STEAMER

"IBSCO" Battery Steamers and Stills are service station equipment, made for battery service. They are made of spun aluminum, thus eliminating all seams and no metal other than aluminum and brass comes in contact with the water. They will open one, two or any number of battery cells, the makers say, in from three to five minutes without any possibility of breaking the jars or injuring the plates in any way.

The steamers are also equipped with a still so that when the equipment is not being used for opening batteries, it is distilling water at the rate of about a gallon an hour. This furnishes the service station with chemically pure distilled water at practically no expense. They are operated with any sort of heating apparatus, gas, kerosene or gasoline. They are not equipped with a heating apparatus, however.

The No. 1 outfit is complete with steamer and still and has an automatic valve so that the operator can attach it direct to the city water and it then requires no further attention so far as the water supply is concerned. It is equipped with a safety valve that keeps the steam at a low rate pressure.

The No. 3 is identical with the No. 1, except that it has no automatic valve and must be fed by hand. It is provided with a glass water gauge, which shows the level of the water in the boiler at all times. The outfit is manufactured by The Illinois Battery Steamer Company, Peoria, Illinois.

## WHITE RADIATOR

THE White radiator, model 1720, manufactured by the F. H. Lawson Company, Cincinnati, Ohio, is designed for all Model "T" Ford cars produced in the years 1917 to 1920 inclusive. The makers claim that there is a column of air for every column of water; ample air space to allow for a



Automobile Engine Heater.



Velvet Recoil Deadener.

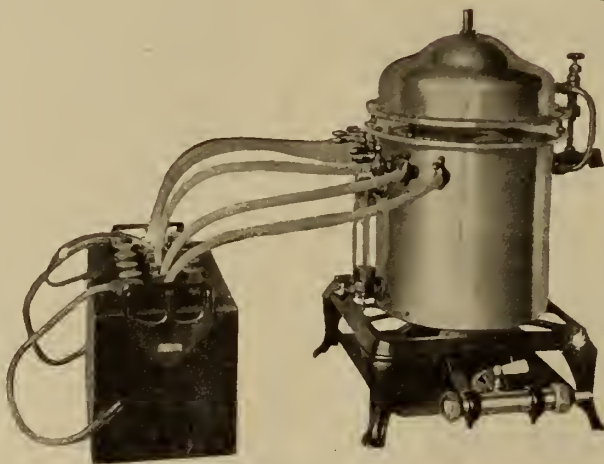

"IBSCO" Battery Steamer.



Lightford Piston.

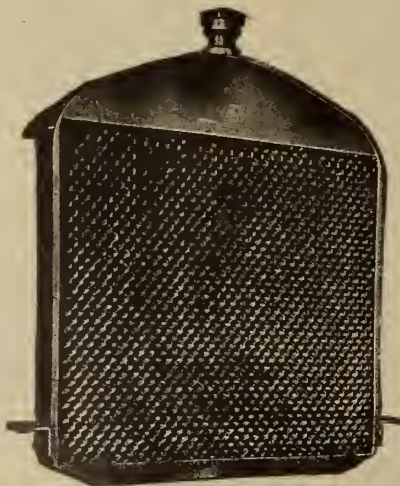

White Radiator.

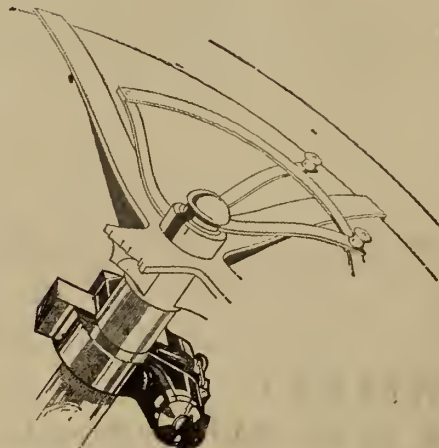

Hershey Car Lock.

current sufficient to cool this volume of water; double the amount of water in contact with the air currents and double the amount of radiating surface. The core is made of soft brass with all joints floated in high-graded solder.

## VELVET RECOIL DEADENER

THIS device is designed to absorb shock by checking spring recoil. It consists of (A) a stationary cam, attached to pivot bolt, (B) which is a part of the bracket which fastens the deadener to the frame of the car. A drum (E) turns the pivot bolt. A spring (C) is permanently fastened to the inside of the drum at D.

When the body of the car goes downward, the makers say, the spring on the opposite side of the drum—not seen in the cut—winds up the drum and instantly takes up the slack in the strap (G). This action then also slides (C) downward on the stationary cam to where it has the least pressure. As the car goes upward on the rebound, the drum revolves, sliding spring (C) up hill on the cam, the cam acting as a brake, until when the spring reaches point (A) on the cam, the pressure is so strong that it stops the up-throw of the car, but has done so gradually. The up-throw has also been held back by the spring on the opposite side of the drum, and this same spring brings the deadener back instantly into position as the car comes down, winding up the strap so as to prevent any slack in the strap. If there is slack in the strap, it will give a bad jerk to the car on the second and third bounces and is likely to break the strap.

The device, manufactured by Blackledge Manufacturing Co., 341 East Ohio Street, Chicago, is made for light, medium, heavy and extra heavy cars.

## LIGHTFORD PISTON.

THE Lightford piston for Ford cars, manufactured by the G. H. Dyer Company, 155 Brookline Street, Cambridge, Mass., is almost identical, the makers say, to the Ford Motor Company's piston, in appearance, construction and design.

It is correct in every measurement and detail, and is made from a very close grained metal capable of taking a high finish. The pistons are guaranteed to be accurately ground and not to vary in weight. They are fitted with two 1/4-in. rings above the pin, and one below, and bronze pin bushing.

## HERSHEY CAR LOCK

THIS theft-proof auto lock, manufactured by the Hershey Manufacturing company, Denver, Col., is of the type that locks the steering wheel. It consists of a nickel-plated ring, attached permanently to the steering part of an automobile. The makers say when the lock is in a closed position a strong case-hardened steel pin passes through the outside steering tube, thus holding the steering gear so that the position of the front wheels cannot be changed.

A cylinder lock which cannot be picked nor forced open is used.

The device is easy to operate and can be locked and unlocked in a second's time—right from the driver's seat.

It is unnecessary to have the wheel in any particular position as the lock is self-adjusting. It can be attached by any person in a few minutes.



# ALLIS-CHALMERS TRACTORS

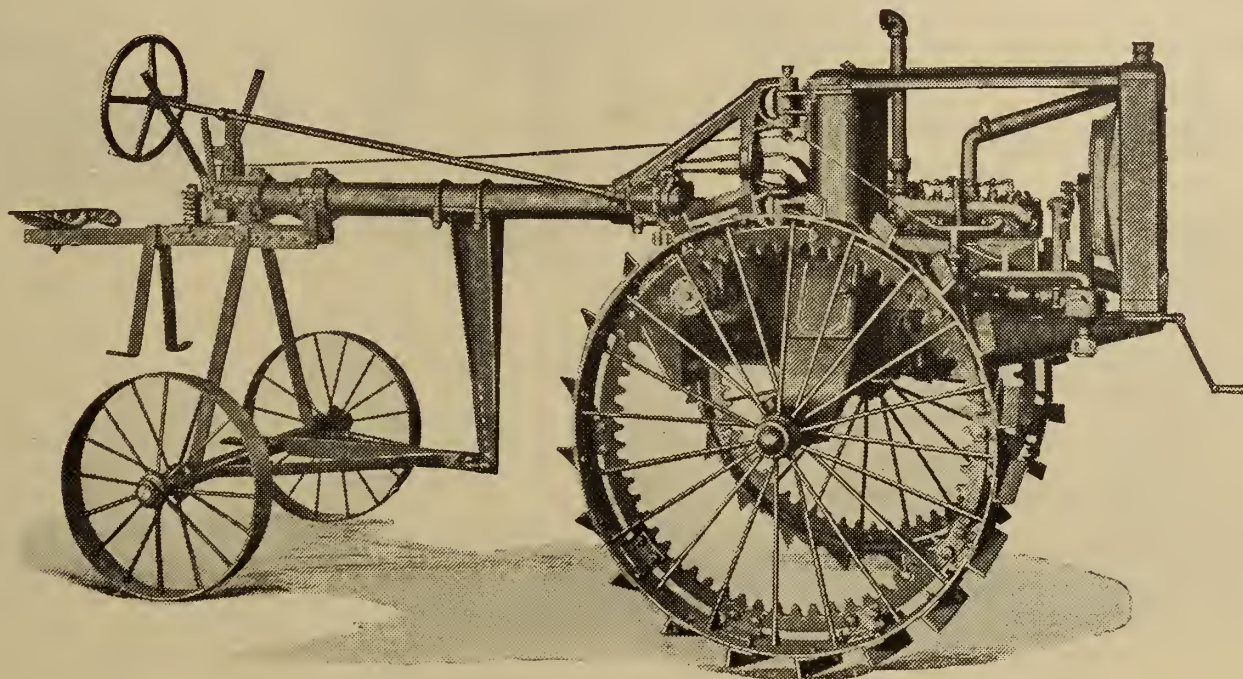

## THINGS EVERY TRACTOR DEALER SHOULD KNOW

You are making up the lines you will handle. Be sure that the connection you make will prove a satisfactory one.

**Look for Business Reputation.** The Canadian Allis-Chalmers Limited and the Allis-Chalmers Manufacturing Company have been known throughout Canada for 65 years as one of the largest manufacturers of quality machinery in the world.

**Look for Manufacturing Ability.** The huge Allis-Chalmers plants, equipped with the most modern machinery, are ready for quality production on a quantity basis.

**Look for Tractor Value.** Study every detail of design—don't be sold on sales talk—see with your own eyes—over \$3,000,000.00 have been spent in perfecting Allis-Chalmers Farm Tractors.

**Look for Adaptability.** Two models are offered to you—the 18-30, a big 4-plow tractor, and the 6-12 General Purpose, a one-man tractor that may be used with any standard implement already on the farm requiring 4 horses or less.

## CANADIAN ALLIS-CHALMERS LIMITED

Head Office: 212 King West, Toronto



## THE BEST BUMPERS OBTAINABLE



"KABEE"  
SPRING ARM CHANNEL  
BUMPER

"LYON"  
RESILIENT BAR  
BUMPER



DURABLE BRILLIANT FINISH  
PATENTED "HOOKBOLT" ATTACHMENT  
FITS 90% OF STANDARD CARS  
OBTAINABLE FROM JOBBERS & DEALERS  
CATALOGUE ON REQUEST

**KINZINGER BRUCE & CO. LTD.**  
NIAGARA-FALLS, CANADA  
SOLE MANUFACTURERS. UNDER  
LYON CANADIAN PATENTS.



## Built Up To A Standard Not Down To A Price

This has always been the policy of the  
manufacturers

The Waukesha Motor, Bosch Magneto, Timken and Hyatt  
Roller Bearings, Baldwin Steel Roller Chains, drop-forged  
heat-treated gears, alloy-steel shafting, copper honeycomb  
radiator, channel and I-beam steels—speak for them-  
selves.

Quality Is Built Into It; You Get Service Out Of It

Write us for particulars of the Wide Drive Drum and the  
Side Hitch, and their many advantages.

**GRAY TRACTOR CO. OF CANADA, LIMITED**  
307 Electric Railway Chambers  
WINNIPEG, MAN.

Norton & Leif, Calgary—Distributors for Alberta.  
C. Waring & Co., 16 High Street E., Moose Jaw—Distributors for  
Southern Saskatchewan.

### CRANE PULLER

AMONG the new devices which have been brought to the attention of service and maintenance men is the Crane Puller Company of Arlington, Mass. This puller is so designed, the makers say, that it is instantly useful regardless of the size of the gear, transmission, pulley, wheel, cam or commutator that requires to be removed.

It is designed along sturdy, heavy lines and is made of high grade material, fitted with adjustable arms and locking screws that afford a certain pur-



Crane Puller.

chase. The pulling screw is made of specially treated metal and fitted with a heavy screw point which is a distinct advantage. By adjusting the diameter and with the smaller sized pullers, as illustrated, it is possible to work on the smallest gears and transmissions.

This tool is furnished with adjustable arms for ordinary pulling operations, but may be had with various special attachments, such as an arbor press base which automatically makes the puller available for arbor press



Crane Puller.

work. A pipe bending attachment is also manufactured for bending pipe, straightening shafting and removing universal joint yokes. The stud fork attachment is an excellent device for removing solid web flywheels, gears and other similar parts.

### VALVE SPRING LIFTER

THE Goodell Pratt Co., Greenfield, Mass., have placed on the market a Valve Spring Lifter which may be used on any make of car. The makers say it is made of drop forged steel, light in construction, and small enough to be used handily in tight places; is simple; the jaws move on hardened rollers, and the screw turns on ball bearings. A turn of the screw forces the bar towards the jaws. As the bar is moved forward by the screw, the distance between the jaws is widened. While in a closed position, the lifter



Valve Spring Lifter

is inserted beneath the valve spring. The lower jaw rests on the engine frame, while the upper jaw lifts the base of the spring. The angle of the jaws, and the simplicity of the lifter as a whole, allows sufficient room to work on the valve stems and remove the pins without difficulty. The larger circular opening on the upper jaw is to allow this jaw to extend above the

small connecting parts on and about the valve stem, allowing them to be easily removed.

### FOOTE STANDARD TRANSMISSION

THE Foote Brothers, Gear and Machine Company, 213-223 North Curtis Street, Chicago, Ill., recently entered a quantity production on a 30-horsepower, 3-plow transmission.

This new model is known as the "F.U." and was designed to answer the demand for a high quality small tractor transmission. It is of the live axle type and

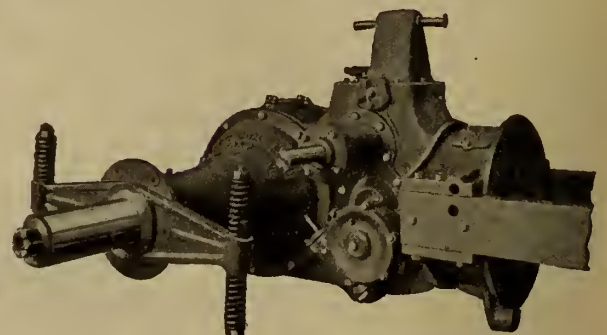

Model "F.U." Transmission.

is built along the same general lines as the 4-plow "D. U." model which has been widely adopted in the trade.

The shafts are of high carbon steel. They are mounted on Hyatt Roller Bearings which receive lubricant direct from the transmission reservoir. The gears are all made from drop forgings carefully hardened and machined. The clutch housing which serves as the engine support is integral with the transmission case. The steering gear is also included as a part of the case. All working parts are completely enclosed and the job is unusually compact.

The design embodies the Foote Exclusive Planetary gear reduction which reduces the gear tooth pressures from 30 to 40 per cent. In order to meet the requirements of special designs, the makers say, a provision is made whereby different reductions may be obtained by using change gears of varying diameter on the sliding gear and belt pulley shafts.

Realizing the growing popularity of the farm tractor for belt work, particular attention has been given to the efficiency and accessibility of the power take-off. The belt pulley shaft is located six inches above the main centre line which leaves ample room for belt clearance.

The complete line for 1920 includes model "F. U.," model "D. U.," model "D." and Model "B.," thereby offering the tractor manufacturer a wide range of selections. Foote Tractor Transmissions are now standard equipment on the Illinois, Shelby, Standard, Dallas, Bolte, Monarch, Turner, Wisconsin, Sterling, Royer, Bulloch, Kenison, Bell, Blewett, Blumberg, Kaws, Essex, Gilson, Trenan, McDonald and Hamilton Tractors.

### IT PAYS TO BURN HEADLIGHTS IN THE DAYTIME

NEXT time you see an automobilist driving along the street in the middle of the day with his headlights turned on, do not yell at him because you think him either stupid or careless. Perhaps he knows what he is doing and is trying to increase the life of his storage battery.

There is as much danger in an overcharged storage battery as there is in one allowed to run down. On long trips during the daylight hours, when the car is operated at speeds of twenty-five miles an hour and over, the battery is liable to be overcharged. When this occurs, the battery overheats. Automatic cutouts sometimes do not work properly, or quickly enough, and burning the lights during a portion of long trips is an added precaution which may save the motorist the price of a new battery.



## A New Canadian Stamping Plant



Pressed metal parts, light and medium weight stampings, card holders, washer, shims, clips, retainers, spacers, cover plates, shells, motor, axle, transmission and clutch stampings—We are at your service with quality and prompt deliveries on any of this work. Send for folder listing 1000 different sizes of washers—Also send us your blue prints and samples for estimates.



To insure convenience and prompt service to our Canadian customers, we have established a factory at Walkerville, Ontario.

The new plant is now ready to do business. It is strictly an independent factory, capable of taking care of any light and medium weight stamping needs you have—and capable, too, of producing the same quality of work which has maintained the reputation of Kales Stampings for 15 years.

**KALES STAMPING CO. Limited**  
61 Walker Road Walkerville, Ont.

### Hindview

Auto Mirrors

Mirrors are required by law in Ontario. "Hindview" is a mirror that has been making good for hundreds of dealers and jobbers in Canada and the United States. Strictly a quality mirror—made for open and closed cars and trucks. Write for descriptive literature.



## "Break Any Sedgley Wrench and We Repair It--No Charge"

**T**HIS is the guarantee under which every "HEXALL" Socket Wrench is sold—internationally-known to jobber, dealer and consumer alike—the manufacturer's bond of faith with his trade in the superiority of his product. **"Break Any Sedgley Wrench and We Repair It—No Charge"**.



"HEXALL" Socket Wrench No. 5—8 pieces

It is a guarantee without strings, "with no questions asked". Whenever you think of "HEXALL", you are bound to associate with it the Sedgley Guarantee.

Think what the "HEXALL" line means to you—how easy-selling it is—the "repeat" sales—the splendid margin in it—the goodwill of such a line that always gives satisfaction and service. Without hesitation, we say that "HEXALL" is the **best socket wrench in the world**—a mechanically-perfect tool that gets to the seat of the trouble quickly and efficiently. **Examine one!** Handles are drop-forged; sockets made from the bar on automatic machines, broached and case-hardened with the skill that comes only through endless years of experience.



"HEXALL" Ratchet Socket Wrench No. 1—16 pcs.



"HEXALL" Ratchet Socket Wrench No. 2—11 pcs.

If you are a jobber, write us—if you are a dealer, write your jobber.

*There are seven sets—a "HEXALL" for every need.*

**R. F. SEDGLEY, Inc.** Est. 1897

Also makers of "BABY" Hammerless Revolvers

2311-13-15 North 16th St., Philadelphia, Pa.

Canadian Representatives: Lamontagne, Limited, Montreal, Can.



# HYATT

## ROLLER BEARINGS For Motor Cultivators

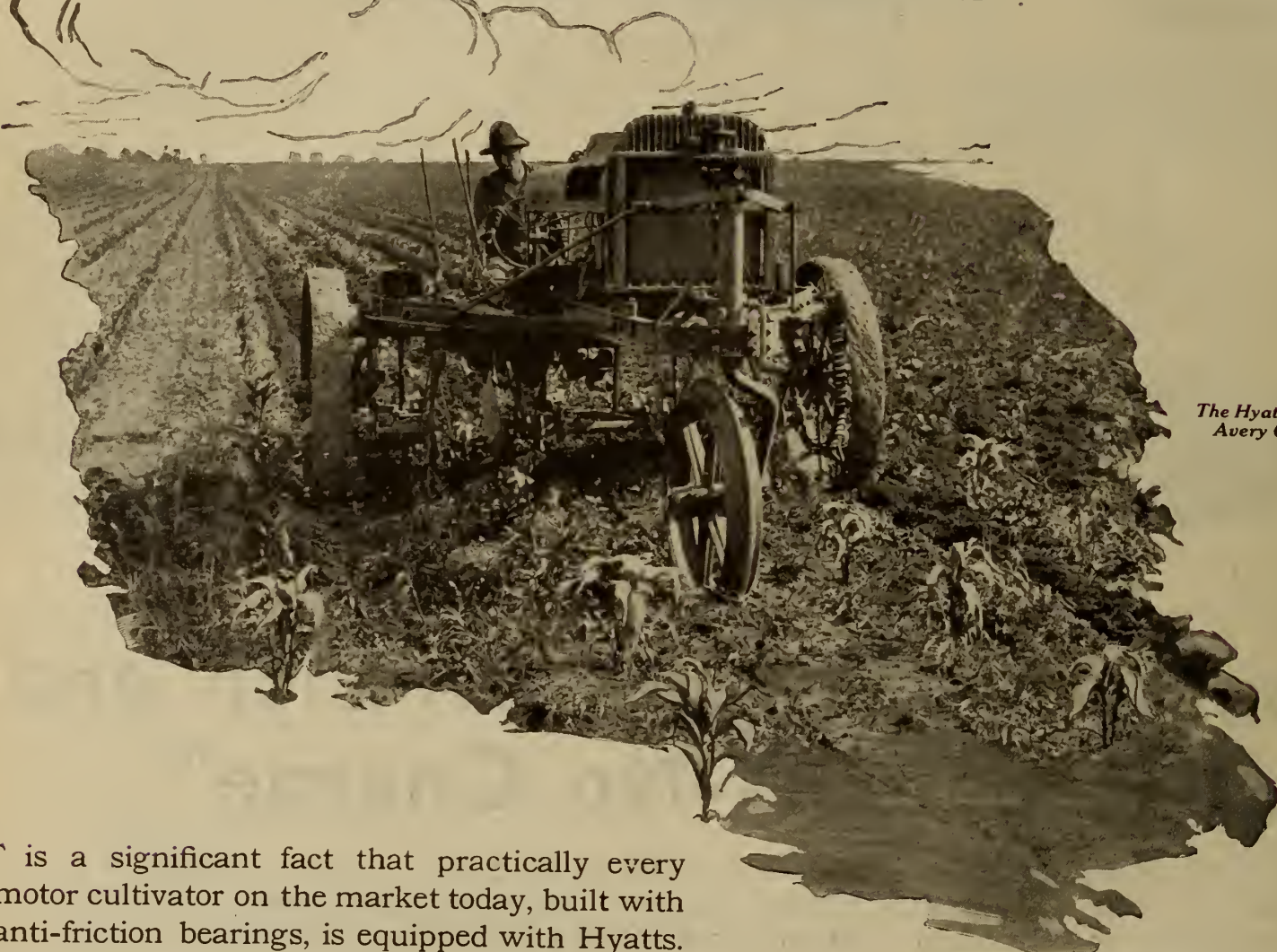

*The Hyatt Equipped  
Avery Cultivator*

**I**T is a significant fact that practically every motor cultivator on the market today, built with anti-friction bearings, is equipped with Hyatts.

Hyatt Bearings keep the cultivator wheels running true, prevent wear and save hours of oiling, because they need oil but once a season instead of twice a day—and do all this under hard duty amid dust and dirt, giving a permanent, care-free performance.

And such are the reasons for the predominance of Hyatt Bearings, not only in motor cultivators, but in all power farming machinery, such as tractors, grain binders, plows, threshers, wind mills, trucks, etc.

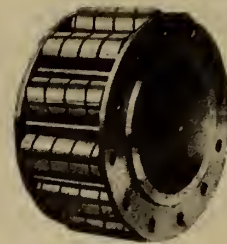

**THE HYATT BEARING** possesses all the desirable advantages found in any other type of bearing—plus the additional advantages of the Hyatt Spiral Roller.

Because this hollow roller is less affected by vibration and shock than a mere piece of solid steel Hyatt Bearings provide against wear most effectively. They give protection that lasts as long as the shafts themselves. They never need adjustment.

### HYATT ROLLER BEARING COMPANY

Tractor Bearings Division, Chicago

Motor Bearings Division  
Detroit

Industrial Bearings Div.,  
New York City

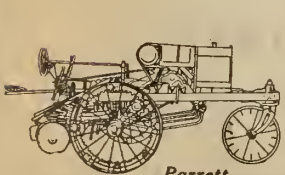

Parrett



Emerson-Brantingham



Case Plow



Bailor



Toro



Rock Island



# Toronto Man Invents Anti-Glare Device

J. C. RYAN, a Toronto mechanic, after considerable experimentation, has developed an anti-glare device. The Toronto Sunday World, describing this invention, says:

The invention, a headlight which will always maintain the axis of the direct beam of light from the deflector, at substantially a constant angle to the horizontal, and which will prevent glaring rays of light being directed upwardly into the eyes of the driver of an approaching vehicle.

First is a headlight supporting frame with a yoke, which passes on each side of the reflector. This reflector is of concave form, and may be constructed in any ordinary manner. At its upper side this reflection is hinged to the upper part of the yoke by means of the trunnions, which are threaded through the ends of the yoke and provided with suitable locknuts, by means of which they may be locked as adjusted. The reflector thus swings from its upper side well above the centre of gravity. It follows from this that the reflector always tends to remain with its optical axis at a constant angle to the horizontal, despite changes in the grade over which the vehicle may be running. This prevents the beam of light from the reflector being thrown into the air when the vehicle passes over the crest of a rise, being thrown in a downward direction when the car tips after passing the crest of a rise.

As, however, the reflector would tend to oscillate, more or less, under the influence of inequalities in the road sur-

set to swing of reflector in either direction.

This device just described effectually damps the oscillation of the reflector, but permits of the reflector moving readily with changes in the grade over which the vehicle is running.

To further prevent direct rays from the reflector being directed upwards into the eyes of driver of approaching vehicle, a segmental concave shield and reflector is provided, one edge of which is substantially co-terminous with the upper part of the rim of the main reflector. The free rim of this shield is so positioned as to cut off all rays from the main reflector, which pass above the horizontal line when the vehicle is standing on level ground.

### ELECT NEW OFFICERS

THE Ontario Good Roads Association recently concluded their eighteenth annual convention. Addresses were given by W. A. McLean, C. E., Deputy Minister of Highways, and Lieut.-Col. W. H. McKendrick.

A resolution was passed favoring an increase in motor license fees as a method of raising money for highway improvements. The convention recommended that the Highway Act be amended to permit Road Commissions to spend road money for tree planting along the highways.

L. E. Allen of Belleville succeeds K. W. McKay of St. Thomas as President. Mr. McKay and C. R. Wheelock of



The truck on the farm shows the new order of things.

face, it is necessary to provide means for dumping these oscillations, leaving the light susceptible only to prolonged changes of the position of the vehicle relative to the horizontal. For this purpose, a cylinder, which is filled with a certain fluid, and having a close fitting plunger which is therein connected to the plunger rod, which extends out through the stuffing box in one end of the cylinder at each side of the piston, thereby controlled by a valve. The greater, or less resistance to the displacement of the fluid may be adjusted by the valve. The swinging movement of the reflector is changed in rectilinear movement of the plunger rod, by means of a Bell crank lever, one end of which is suitably connected with the reflector, while another arm is pivotally connected with a plunger, making connection with the reflector by means of a pin and slot connection.

Provision for the varying distance of the pivotal connection, with a plunger rod from the free run of the Bell crank lever, is provided by pivotally connecting the cylinder to the frame.

Set screws are placed in the plunger rod to limit the move of the plunger in either direction, so that a limit is

Orangeville, another past President, were made Honorable Presidents of the association. Other officers elected were: Vice-Presidents: T. J. Mahoney, Hamilton, and W. H. Brown, Chesley; Secretary-Treasurer, Hon. George S. Henry, Todmorden; Directors, F. A. Senecal, Plant agent; J. A. Sanderson, Oxford Station; William Nugent, Belleville; W. H. Pugsley, Richmond Hill; Major T. L. Kennedy, M. P. P., Dixie; J. E. Jamieson, Singhampton; John Currie, Strathroy; J. E. Waters, Niagara-on-the-Lake, and S. L. Squire, 98 Albany avenue, Toronto.

### NEW AUTO REGULATIONS

CHIEF GRASETT, Deputies Dickson and Geddes, and Inspectors Mackie and Bond will draft new traffic regulations to ease the congestion on downtown streets. Representatives of the Board of Trade, Motor League, Safety League and Toronto Railway Company, who conferred with the police, declared that the regulation forbidding motors to stand on streets between Wellington York, Queen and Church streets was too drastic, and suggested a limit of fifteen minutes for these streets.

## Try This Test on BT Leathers



Put any BT Pump Leather in a bucket of water and leave for several hours. The BT Leather will remain quite as firm as when first put in the water. BT leathers act in just the same way when put on a pump. A plunger fitted with BT Leathers will maintain a water-tight and air-tight fit long after other leathers have become as limp and useless as a wet rag. Better hides are used in BT Leathers, and greater care is taken in the process of manufacture.

Find out more about BT Leathers, Cylinders, Pumps, etc., by writing to

### Beatty Bros., Limited

Winnipeg, Man.    Fergus, Ont.    Montreal, Que.  
Edmonton, Alta.    London, Ont.    St. John, N. B.  
16 Holborn Viaduct, London, England

Well  Pumps

## CONTRACT NOW FOR Viking Separators

*Get protected territory*

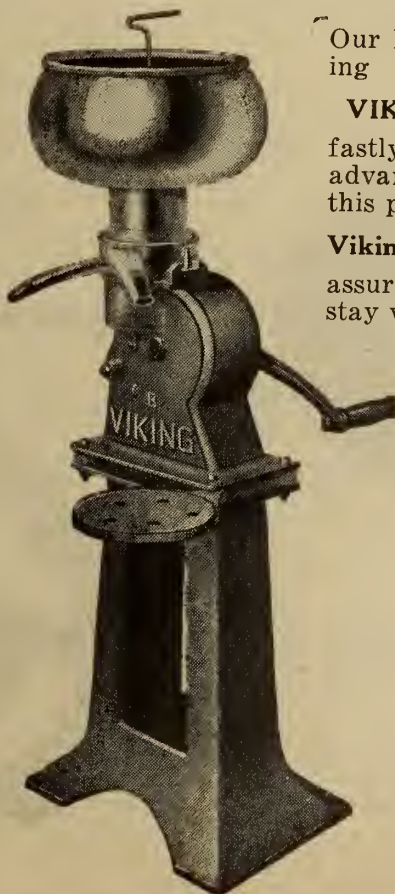

Our liberal business policy is pushing

### VIKING CREAM SEPARATORS

fastly to the front, every reasonable advantage is yours if you handle this popular separator.

### Viking Service to Your Customers

assures you of a business that will stay with you. Viking maintenance guarantee is broad, strong and absolutely fulfilled at all times by the Company.

### Viking Profits to the Dealer

are 10 to 20% greater than on other lines. If you are in the business for the profit that is in it, then a Viking contract will certainly please you.

Write to-day for particulars and territory.

Dept. B.J

## Swedish Separator Company

MONTREAL—422 Power Bldg.  
WINNIPEG—714 Confederation Life Bldg.



# FYRAC

## Spark PLUGS

### One INCH Firing Surface

*Canadian Money at Par*

Heavy Duty—the strain of deep-in-the-mud truck haulage, the blistering grind of tractor and implement plodding through the fields—at these Fyrac flings its challenge.

The heat-proof, oil-proof stone insulator on Fyrac Heavy Duty Spark Plugs—the surpassingly durable wires that receive those sheets of fire leaping from *one inch firing surface*—all are plainly discernable at the customer's first glance, all plainly tell the hard, rough service for which they are fitted.

So Fyrac sells itself—by intensive advertisement, by placard and show card—by *the plug*—in your store.

FYRAC MANUFACTURING COMPANY, *Rockford, Ill.*

Canadian Department

Campbell Agencies, 350 Mc Kinnon Bldg., Toronto, Can.

Export Department, Werner & Butts, 336 Whitehall Building  
New York, U. S. A.



*Durable*

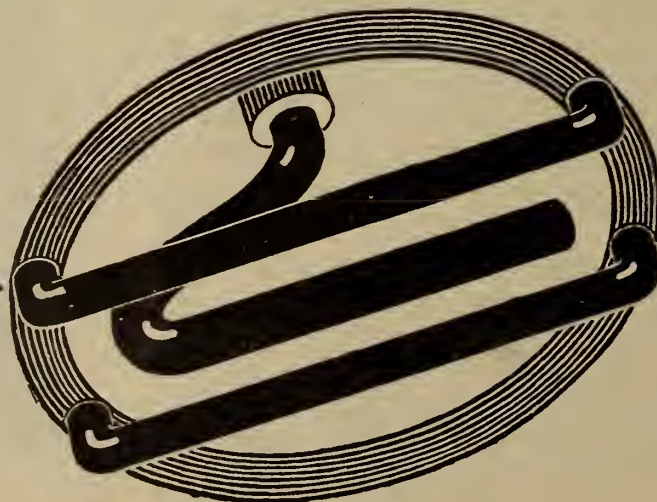

#### ONE INCH FIRING SURFACE

This shows the central electrode, from whose *one inch firing surface* sparks leap the gap to the stout right and left wires, made to live long. *One inch firing surface* insures reliable power, and prevents gasoline-formed carbon.



**AUTO TOUR OF VANCOUVER MERCHANTS**

THE members of the Vancouver Wholesale Merchants' Bureau of the Board of Trade have arranged an automobile tour this summer and the following itinerary proposed by the committee has been adopted:

Leave Vancouver Friday, June 11 on 10.30 a.m. boat for Victoria; leave Victoria 3.00 p.m. for Duncan and stay over night; Saturday, June 12 leave Duncan at 9.00 a.m. for Lady Smith and Nanaimo. Lunch at Nanaimo; leave for Albernia 3.00 p.m. dinner and stay all night. Sunday June 13, leave 9.00 a.m. for Parksville; lunch at Parksville. Leave 3.00 p.m. for Union Bay, then on to Courtenay for dinner and stay over night. Monday, June 14, spend time motoring around Courtenay and Cumberland. Lunch at Parksville; dinner at Nanaimo. Arrive Vancouver Tuesday morning.

A canvass has been made and the following gentlemen have signified their intention of being present with cars; J. B. Thomson, of Jas. Thomson & Sons; J. J. Thompson; Kelly, Douglas & Company; Gault Bros.; W. A. Allan, of Canadian Consolidated Rubber Company; J. Galloway, of McClary Mfg. Company; F. P. Milson, of McLennan, McFeely & Company; Vancouver Milling & Grain Company; A. P. Slade; C. F. Disher; Alex. Marshall.

**ANNUAL GOOD ROADS CONVENTION**

THE announcement that the Seventh Annual Canadian Good Roads Convention is to take place at the Royal Alexandra Hotel, Winnipeg, on June 1, 2, and 3 marks the first occasion in which this organization has gone west of Ontario in order to foster the campaign for improved highways, so that special efforts are being made by the executive of the Canadian Good Roads Association to ensure its success. The programme, which is now in course of preparation, is one that will specially appeal to the Western municipalities, as apart from the general papers on different methods of paving, there will be given addresses dealing particularly with the road conditions and problems which exist in that portion of the Dominion.

The convention meetings will be held in the banquet hall and there will be an exhibition of road materials in the old ball room. While in the spacious ground in the rear of the hotel will be shown road and other machinery in operation. It is also proposed to construct a section of highway in the district under the supervision of the best experts on the continent who will thus be able to demonstrate the proper method of grading, ditching, draining, foundation laying and building up of a modern highway.

The Lieutenant Governor of Manitoba, Sir James A. M. Aikins, Kt., has been invited to formally open the convention, and invitations are being extended to the Premiers of every province in the Dominion, as well as the Ministers of Highways and other ministers to be present.

The deputy ministers of highways from all the provinces are being specially invited as it is intended to hold special meetings for them for the purpose of discussing road laws, traffic regulations, automobile taxation, systems of construction and maintenance of highways and similar questions with a view to arriving as far as possible at a uniform system of regulations for the whole Dominion. Representatives of the Federal Government will also be present at this conference, which will commence on the second day of the convention and proceed concurrently with it.

Information has already been received by the secretary, George A. McNamee, that large delegations will be sent from the Ontario Good Roads Association, the Eastern Ontario Good Roads Association, the Good Roads League of British Columbia, the New Brunswick Automobile Association, the Halifax Good Roads Association, the

Quebec Automobile Club, the Automobile Club of Canada, the Central Canada Colonization and Highways Association of Fort William, the Pacific Highway Association of Maryhill, Washington, and other organization, and special Pullman cars are being arranged at all the big centres for the conveyance of delegates to the convention. Ladies are being invited to join the party, and the railway companies are arranging several trips from Winnipeg to allow delegates and their wives to visit points of interest in the West.

The annual meeting of the Canadian Automobile Association will be held at Winnipeg during the convention, with representatives from all the recognized automobile organizations in the Dominion attending.

**NORTHERN ELECTRIC CATALOGUE**

THE Northern Electric Company has just issued a new automatic accessory for 1920. It is the largest book the company has yet produced, having 284 pages and containing a very complete list of accessories and parts.



The cover design is appropriate and the color scheme is effective. The accessory list has been carefully selected for its quality and dependability. In addition to the above, a four-page insert—printed in four colors—describes the company's ignition and starting and lighting cables; and all commodities which are especially adapted to the Ford car are included in a special insert of forty-eight pages.

**IMPORTANT TRACTOR DECISION**

THE privy council of Calgary handed down a decision, recently in a case of litigation, which puts the manufacturers of tractors under an obligation to see that their machines deliver the rated horse-power. The decision gives a tractor purchaser the right to bring action against the manufacturers when he finds that his machine fails to deliver the horse-power claimed for it.

**A BOOMERANG**

In honor of a visit to his plant by the Governor of the State, an automobile manufacturer once had a complete car assembled in something like seven minutes. Some weeks after this feat was heralded in the daily papers the phone at the factory rang vigorously.

"Is it true that you assembled a car in seven minutes at your factory?" the voice asked.

"Yes," came the reply. "Why?" "Oh, nothing," said the calm inquirer, "only I've got the car."—*E.B. Dealer Magazine.*

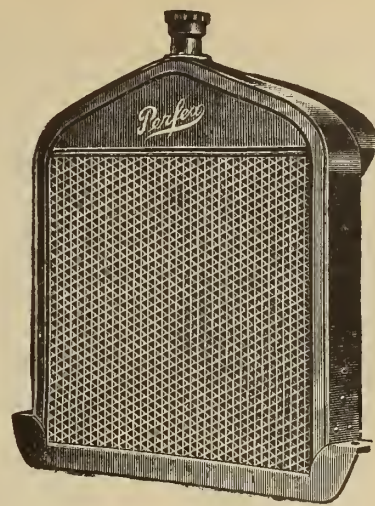

**PERFEX**

*The Perfect Radiator*

Perflex radiators for Fords are a quality product embodying features that cannot be had in other radiators.

A patented spring bracket suspension and a real radiator core of great efficiency.

*The last word in Radiator construction*

**Perflex Radiator Co., Racine, Wisconsin, U.S.A.**

**P. A. C. McINTYRE & CO., WINNIPEG, CANADA**

Manufacturers Agents for

British Columbia, Alberta, Saskatchewan, Manitoba, Canada



**Auto Lamps  
and  
Coppered Oilers**

**Buy Them in Canada!**

**Dealers!**

**You will profit by  
Guaranteed Quality  
Better Delivery  
Lower Costs**

*Write for catalog*

**Canadian Lamp & Stamping Co., Ltd.**

**Ford City, Ont., Canada**





# The Cox "Atmos" Carburetors

**E**FFICIENCY, to-day, is invariably based on the results attained.

This statement is particularly true in relation to engineering achievement. The successful operation of any mechanical device or machine is dependent on the scientific application of the principles involved in its construction.

In the design of the Cox "Atmos" carburetor the inventor has endeavored to apply the venturi principle in such a way that the maximum efficiency of the carburetor is attained under every possible working condition. On a trial, recently, we were given a practical demonstration of the effective action of the carburetor under actual

incidents of special interest. The car could be run steadily at 5 miles per hour, on top gear; would accelerate readily from that speed without the least apparent effort, and at about 10 m.p.h., the throttle was thrown open violently with an unflinching response from the engine, and the car would take a fairly steep hill, on top gear, at high or slow speed, as desired.

Three of the outstanding advantages claimed for the Cox carburetor are: economic operation, even at the highest speeds; the ability of providing any strength of mixture on intermediate throttle positions without interfering in any way with the full throttle condition; and, entire absence of gallop-

section of the main venturi tube is located in the throttle barrel itself, so that with a partially closed throttle the perfect venturi tube no longer obtains, and the result is the distortion of the main air flow. Under ordinary conditions the consequence would be to generate a mixture over rich, with a relative waste of fuel. In the Cox carburetor this difficulty is overcome in a simple manner by the introduction of auxiliary air ports in the subsidiary choke tube and on the engine side of the jet. These ports are gradually opened or closed by the revolving of the barrel within a sleeve attached to the barrel casing. Closing the throttle opens the air ports, or vice versa, so that with the throttle closed to a slow running position the ports are wide open and the flow through the subsidiary venturi is ma-

marine and stationary service. They are made by the Cox "Atmos" Carburetor Company, Ltd., of Birmingham, England, and are being placed on the Canadian market by the British and Foreign Agencies, 17 St. John St., Montreal.

## IMPLEMENT INDUSTRY IN CANADA

**T**HE Dominion Bureau of Statistics has compiled a preliminary report of the Agricultural Implement Industry in the Dominion for the calendar year 1918, covering the operations of 84 plants, distributed by provinces as follows:

Ontario 40, Quebec 22, Manitoba 7, Alberta and Saskatchewan 4, and Prince Edward Island 2.

The total capital invested in the industry for the Dominion in 1918 was \$74,410,603. Distributed according to provinces, Ontario shows an investment of \$69,394,156, Quebec \$3,643,079, Manitoba \$1,292,784, Alberta and Saskatchewan \$43,924, and Prince Edward Island \$36,660. Land, buildings and fixtures amounted to \$13,528,395; machinery and tools to \$5,972,530; materials on hand, stocks in process, finished products, fuel and miscellaneous supplies to \$29,614,647; and cash, trading and operating accounts and bills receivable to \$25,295,031.

The number of persons employed in the industry was 9,647 males, and 448 females, and wages amounted to \$10,282,539. The total value of all the fuel used during the year was \$913,937, made up of 60,385 tons of coal of all kinds worth \$413,422; coke, 15,982 tons worth \$174,970; fuel oil, 2,408,233 gallons worth \$297,823; gasoline, 16,187 gallons worth \$5,207; wood, 2,095 cords worth \$7,234; gas, natural and artificial, 21,635 M. cubic feet worth \$12,996, and other fuel to the value of \$2,285. Canadian or domestic fuel amounted to \$278,265, and foreign or imported fuel to \$635,681.

The total cost of miscellaneous expenses for the year amounted to \$2,357,770.

The cost of materials valued at the total selling value of all products at the point of production was \$34,853,673.

## EDUCATIONAL CONVENTION OF LIGHTNING ROD DEALERS

**A** DECIDEDLY new note in conventions was struck by the dealers of Shinn-Flat lightning rods, at their convention, in the Wellington Hotel, Guelph, on April 1st and 2nd. It was more of an educational short-course than a business convention.

The manager of the Shinn Manufacturing Company of Canada is Professor W. H. Day, who was for sixteen years Professor of Physics at the Ontario Agricultural College. During that time, the prevention and control of lightning was one of his chief hobbies, as well as one of the main points in his course of instruction to students.

By the time the convention was nicely started, Prof. Day imagined that he was back lecturing to a class of students, and kept his audience ever on the alert while he propounded the theory of lightning flashes and their controls.

W. C. Blackwood, who is now Professor of Physics at the O. A. C., followed with an address on, "What Constitutes a Good Lightning Rod." R. R. Graham, Lecturer in Physics at the O. A. C., presented facts from some actual cases of improper rodding. E. P. Heaton, Ontario Fire Marshal, read a paper on The Fire Marshal's Office and Lightning Rods.

The business end of the convention was taken over by C. G. Campbell, Sales Manager for the Shinn Manufacturing Co. of Chicago, and by J. D. Lang, dealer of Lambeth, Ont. Similar conventions are being held at Ottawa, and Sherbrooke, Que.

**VANCOUVER.** — Messrs. George Rowlings and Robert Bruce have opened the Ideal Repair Shop at 805 Pender Street West. They are specialists on Ford repairs.

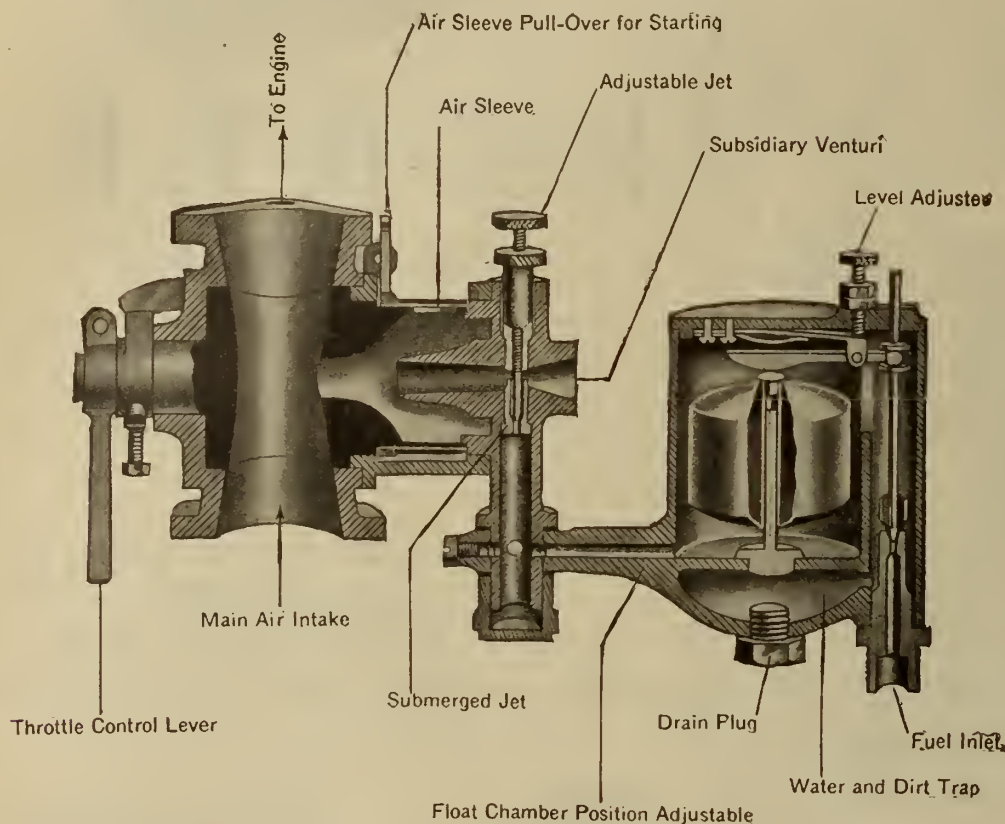

post-winter conditions and when the roads were at their worst.

The easy starting of the engine after a long stop, was a pleasing feature, the engine starting at the first swing of the starting handle, and firing regularly without galloping. At no time was there the least difficulty experienced in the even distribution of the correct mixture to the engine, when running anywhere within the entire speed range.

Various driving experiments were made to exhibit the extreme flexibility and sensitive control of the carburetor action. Slowing down in traffic and for bad holes and other road obstructions, and the subsequent fast getaway, were

ing, hesitation, and such defects as are frequently experienced in twin or multijet carburetors, or those provided with various valves and compensating devices.

The principal feature of the "Atmos" carburetors, the makers say, is the elimination of the possibility of over-richness of the gas mixture, a condition that has always been an expensive and troublesome one to car owners. To overcome this objection of irregular gas mixture, the makers of the Cox carburetors have introduced a detail in construction that tends to equalize the flow of air and gasoline, so that the mixture is always uniform in proportion to the volume used. The

terially reduced. The air sleeve is so supported that it may be rotated by a pull wire connected to a lever to close the ports when starting on a partially open throttle.

The jet through which the gasoline is drawn is of interesting design, as it is constructed to give the most effective atomization of the fuel when mixing with the air coming in through the subsidiary venturi. The jet opening is located somewhat below the point where the oil meets the air, and it is claimed that this construction adds greatly to the efficiency of the operation.

The float chamber likewise has some distinct features. The float itself moves on a central rigid pin and the level of the gasoline is regulated by the adjustment shown at the top of the float chamber. It will be seen that the needle valve that controls the passage of the gasoline from the main supply tank, is located in a separate chamber which is so constructed that all foreign matter is prevented from passing into the float chamber, as it accumulates in a trap at the bottom, from which it can be drained from time to time.

The working adjustment of the carburetor is a simple matter and is accomplished almost entirely by two screws, the master adjustment being that at the jet, and the other being the regulation of the rise of the float in the float chamber.

The general construction of the carburetor is such that it can be placed on the engine in a vertical or horizontal position, with no change in the effective operation. While these carburetors were primarily designed for automobile use, they have been successfully adapted to gasoline engines in

## Big Profits--Quick Sales

Write for Proposition

### Streamline Hood

For old style previous to 1917

## Ford Cars

This Hood on a 1915 Ford. Note the up-to-date appearance

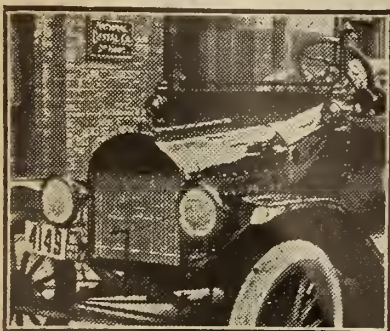

The Burrowes Mfg. Co., 611 King St. W., Toronto, Ont.



# The Right Thing to Sell Is the Thing that is Right

There has never been a better time than the present for implement agents and dealers to connect up with a real, live line of potato machinery.

## O-K CANADIAN PLANTERS, SPRAYERS and DIGGERS

O.K. Canadian Planter No. 25 in Operation in Carleton Co.,  
New Brunswick.



2-Row Sprayer on the Farm of D. W. Panabaker,  
Hespeler, Ontario.

have passed far beyond the experimental stage and have reached that state of perfection where they are giving excellent satisfaction to hundreds of potato growers all over the Dominion.

The demand for modern machinery to handle extensive crops of potatoes has been created largely by the universal success of our planters, sprayers and diggers. They have been tried and found trustworthy.

O-K CANADIAN planters, sprayers and diggers are time, labor and money saving machines constructed of the best and most durable materials. They are simple of operation, easy to keep in repair and will meet every requirement of the potato grower.

O-K CANADIAN sprayers include the two-row and the four-row sprayers and the O-K-SPRA, which is a knapsack sprayer. All are equipped with the Efficiency Non-Clog Nozzle and are guaranteed against any defect.

*Write today for selling proposition and literature*

**Canadian Potato Machinery Co., Limited**  
GALT, ONTARIO

# ANNOUNCING HYSLOP'S 1920 AUTOMOTIVE EQUIPMENT CATALOGUE



## Automotive Equipment, Garage Supplies, Tires and Accessories

This new book is just off the press and being distributed to dealers throughout the Dominion. It contains illustrations and descriptions of the latest and best equipment for automobiles, trucks and tractors.

A special section is devoted to Garage Equipment, featuring such lines as Adjustable Motor Stands, Crankshaft Straightener, Piston Aligning Machines, etc.

If you have not received a copy of our 1920 catalogue a postal request will bring you one by return mail together with discount sheet.

**HYSLOP BROTHERS, Limited**  
Toronto, Ontario



## Aikenhead's

Our 1920 Accessory Catalogue is  
just off the press

If you have not received a copy, a postal card will bring one by return.

This book will interest every dealer in Automotive equipment.

We stock everything in Accessories, Tools and Garage Equipment.

Have you received your copy?

**Aikenhead Hardware Limited**

Toronto, Canada

## Why Don't You Sell SHINN-FLAT

?

### It will pay you well

There are many buildings right in your locality that should be equipped with Shinn-Flat Lightning Rods. It is your duty as a neighbor to see that every building in your locality is protected against lightning.

## Shinn-Flat

LIGHTNING RODS

Guaranteed 100% Efficient. There is a nice profit for you on every order. Our system of dealing with agents is most satisfactory to all concerned.

Write for terms—NOW

**Shinn Mfg. Co. of Canada, Ltd.**  
GUELPH, ONT. Prof. W. H. DAY, Sec. and Mgr.

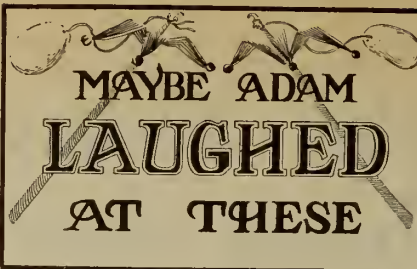

Ouch!

Mr. Saphedde—Do you think men have descended from monkeys?  
Miss Caustique—Not very far.

\* \* \*

#### A Modern Miracle

Behold the pretty cotton plant  
With blossom white and full!  
They pick the downy stuff and, lo!  
They make us suits of wool!  
—Spokane Spokesman-Review.

\* \* \*

#### The Life of the Land

"In what direction does the village lie, my friend?"  
"Well, sir, it's liable to lie in any old direction that comes handy, but at this time of the year it's mostly about fish."—London *Blighty*.

\* \* \*

#### Didn't Know His Prospects

"I understand you want to marry my daughter. What are your prospects?"  
"Not being a mind reader, sir, I am afraid I cannot say until you tell me."—Edinburgh *Scotsman*.

\* \* \*

#### Nevertheless, Get Busy

"There's unfortunately a lot of difference between expectation and realization."  
"You bet! As a concrete example, take reading a seed catalog in the spring and looking at your garden in the fall."—Boston *Transcript*.

\* \* \*

#### Unappreciated Wit

"Men are really too mean for anything."  
"What's the trouble now?"  
"Why, I asked John for an automobile to-day and he said that I must be contented with the splendid carriage that nature has given me."—New York *American*.

\* \* \*

#### Where It Belonged

An amateur authoress who had submitted a story to a magazine, after waiting several weeks without hearing from the editor concerning it, finally sent him a note requesting an early decision, as she stated "she had other irons in the fire."

Shortly after came the editor's reply: "Dear Madame: I have read your story and I should advise you to put it with the other irons."—Punch.

\* \* \*

#### Misses Don't Count

Two Irishmen arranged to fight a duel with pistols. One of them was distinctly stout, and when he saw his lean adversary facing him he raised an objection.

"Bedad," he said, "I'm twice as big a target as he is, so I ought to stand twice as far away from him as he is from me."

"Be aisy now," replied his second. "I'll soon put that right."

Taking a piece of chalk from his pocket, he drew two lines down the stout man's coat, leaving a space between them the width of his lean opponent.

"Now," he said, turning to the other man, "fire away, ye spalpeen, and remember that any hits outside those chalk lines don't count."—*E-B Dealer Magazine*.

#### APPROVED PARKING LOCATIONS FOR TORONTO

THE following parking locations with a two-hour limit are approved: Temperance, centre of street from 50 feet west of Yonge to 50 feet east of Bay; Gerrard, north side, Jarvis to Sherbourne, except opposite Horticultural avenue; Gerrard, south side, Church to Victoria; Gould, north side, Church to Victoria; Victoria, east side, Gould to Gerrard; Shuter, south side, Church to Bond; Bond, east side, Dundas to Queen; Mutual, west side, Queen to Shuter; Mutual, west side, Wilton to Gerrard, after 6 p.m. for the convenience of Arena patrons; Adelaide, south side, opposite St. James' Cathedral; George, west side, Duke to Duchess; Front, south side, from west side of Customs House to Bay Street; Bayside Park, north and south sides; Sheppard, west side, Temperance to Adelaide; Richmond, south side, west from York to John; Emily, west side, King to Wellington; Simcoe, west side, Adelaide to Wellington, after 6 p.m. for convenience of theatre patrons; Duncan, west side, Adelaide to Queen, after 6 p.m. for convenience of theatre patrons; Richmond north side, John to Duncan, opposite Methodist Book Room; St. Patrick's Market square; Spadina avenue, both sides, from Queen street north to where police designate; Devonshire place, west side, Bloor to Hoskin; St. Mary's, south side, from Yonge westerly; Grenville, south side, Yonge to Elizabeth; Elizabeth, west side, Louisa to Albert; Trinity square, opposite Trinity Church; Albert, south side, Yonge to James, after 6 p.m.; James, west side, Queen to Albert; Tyndall, west side, King to Springhurst, after 6 p.m., during exhibition; Spencer, west side, King to Springhurst, after 6 p.m., during exhibition; Cowan, west side, King to Springhurst, after 6 p.m., during exhibition; Wellington, south side, York to Simcoe; Richmond, centre from Church to Jarvis; Lombard, centre, from opposite 27 to 108; Church, east side, from King to Adelaide; Market, centre, King to Front; Albert, north side, from Yonge street lane to Chestnut; Chestnut, west side, Queen to Armouries; Osgoode, centre University to Chestnut; Court, south side, Imperial Oil station westerly.

"One way" streets designated are as follows: Victoria, between Colborne and Adelaide, northbound traffic only; Leader lane, southbound traffic; Colborne, between Yonge and Church, eastbound; Jordan, southbound, Bertie, northbound; driveway, east side, Queen's Park, northbound; driveway, west side, southbound; Spadina, on east side Knox College crescent, northbound; west side, southbound.

Sign standards are to be placed for the direction of drivers. The time limit in approved parking places is to remain two hours as at present fixed by the Police Commissioners and to be shown on the standards.

#### A CORRECTION

In the March issue of M. T. I. the prices of the Ford and Briscoe models for 1919 and 1920 were misquoted, they should have read:

Car Model	Price		Increase
	1919	1920	
Ford Runabout	\$ 660	\$ 710	\$ 50
Touring	690	740	50
Coupe, fully equipped	1,000	1,050	50
Sedan fully equipped	1,200	1,250	50
Briscoe Roadster	\$1,350	\$1,450	\$100
Touring Standard	1,350	1,450	100
Touring Special	1,485	1,560	75
Sedan	2,145	2,145	No Incr.

"What caused the fight down at Johnson's Dairy Farm?"

"Oh, Bill Simmons called one of the farm hands 'Oleo'."





## Chase power is driving power

### Both rear wheels get the same steady driving power

There the Chase differs from other tractors.

It has no differential gears.

No matter what trouble it may get into, what obstacles it meets, however rough or uneven the going may be, the power of the Chase drives both rear wheels to pull through.

Differential gears add nothing to the operation of a tractor.

They do cause many tractor troubles.

When one wheel strikes an obstacle, the differential throws the power into the other wheel—where it is least needed—and makes the tractor practically a one-wheel-drive machine.

That is why some tractors cannot pull through when they get into holes or bad going. One wheel goes "dead" and the other spins. The power of the motor cannot be used to move the tractor.

#### So The Chase Stays on the Job

The Chase Tractor, having no differential gears, has an equal positive drive on both rear wheels, and thus gets the full benefit of the driving power of the heavy-duty motor.

This means that the Chase is not easily blocked, and consequently stays on the job more hours per day.

#### Less Strain, Less Wear

And this no-differential feature of the Chase insures longer service because it avoids uneven wear of parts.

Even in ordinary plowing on the level,

the side-draft has a tendency to make one wheel do more work than the other. A tractor with differential gears cannot pull evenly under that side-draft. It becomes again a one-wheel-drive machine. It gets uneven wear and uneven strain, which must shorten its years of service. The Chase Tractor pulls evenly—and so wears evenly.

#### Also Saves Kerosene

It also operates more economically—uses less fuel.

For two reasons. First, driving through gears wastes about 10% of the power. The Chase saves that 10%. Second, the even pull requires less power and uses less gas.

This no-differential feature of the Chase Tractor is but one of many evidences that the men who make it know what a tractor ought to be. From the heavy-duty Tractor motor to the smallest bolt in its construction, the Chase is "built to build goodwill."

#### World-wide Industry

Canadians build the Chase—in Canada. Canadians build the Chase that is sold in Great Britain and foreign lands—yes, and also in the United States. The Chase institution was created to establish in Canada a world-wide tractor business founded on Canadian principles of doing business. The men behind it, R. J. and W. J. Cluff, are men of high manufacturing ideals. They are exacting in their demands. They want the

men who buy Chase Tractors to make money out of them. They are determined that every customer shall receive the service he requires to keep his Chase Tractor always at its best and always "on the job."

#### You can make Money with a Chase

You will find it to your advantage to deal with an institution with these ideas of service. You will find that the Chase Tractor is a piece of machinery that will gladden your eye. If you haven't seen it, be sure to do so. Or, write for illustrated literature and detailed information. We will send it promptly and tell you where you can see a Chase Tractor.

#### SPECIFICATIONS

**Motor**—Buda Model H.T.W. Heavy duty, Tractor type 4 cyl. 4¼" bore, 5½" stroke. Set cross-wise of frame. Every part readily accessible. Extra large water passages for cooling. Force-feed lubrication, thorough vaporizing of low-grade fuels. Heated and "water washed" air.

**Fuel**—Specially designed to burn Kerosene or low-grade gasoline.

**Drive**—No differential gears are used, the drive being direct from the transmission to outer rim of wheel through bull pinions and gears. Both bull pinions and bull gears cut from forged steel and case-hardened.

**Transmission**—Fully enclosed and running in oil. Myatt roller bearings. Very simple type. Gears accurately machined from high grade steel.

**Chain Drive**—Power is delivered to the transmission gears by a wide chain fully encased and running in oil.

**Belt Pulley**—In direct line with crankshaft—no bevel gears. Located at side—best position for lining up with the machine to be driven.

**Control**—Driver has unobstructed view. Control levers are simple and easy-working.

**Turning-radius**—12 feet circle.

CHASE TRACTOR CORPORATION, LIMITED, TORONTO, ONTARIO





Tool Locked in Position  
for Removing or Replacing Tire.

## K.P. Universal Rim Tool

The easiest way to remove tires from split rims. Fits all types of cross-cut, demountable rims in use to-day.

Collapses a rim no matter how badly a tire may be stuck to it.

Holds rim collapsed while tire is being removed or replaced.

Forces the rim back on tire again with the utmost ease and locks the rim in its original position, even in the case of tires which are under-sized.

Price \$6.00 in Canada

K. P. PRODUCTS CO., Inc.  
250 West 54th., St., New York, N.Y.

Sold by

**Northern Electric Company**  
LIMITED

Montreal, Quebec, Toronto, Winnipeg, Calgary, Vancouver, Halifax,  
Ottawa, London, Regina, Edmonton.



## The Plug with the HOTTER SPARK

The ball point of the "M&S" plug creates a larger and hotter spark, causing more complete combustion. This hot spark will give your car new life and more power.

The three-in-one terminal is adapted to any style ignition wiring. The high-grade chemically glazed porcelains are interchangeable—one porcelain fits all plugs.

### Models

- 500— $\frac{1}{2}$ " Standard.
- 501— $\frac{3}{8}$ " Standard
- 502— $\frac{7}{8}$ " Long
- 503— $\frac{7}{8}$ " Long with  
Chevrolet Terminal
- 506— $\frac{1}{2}$ " Long
- 504—Regular Porcelain
- 505—Chevrolet Porcelain

Dealers—The "M & S" plug is standard equipment on the new Overland "4." Ask your jobber for them.

**Machine & Stamping Co., Limited**

Commercial Dept.

**RUSSELL MOTOR CAR CO., LIMITED**  
1209 King Street West  
TORONTO

26

## NEWS — OF THE TRADE FOR THE TRADE

### MARITIME PROVINCES

**MONCTON, N.B.**—Wm. Mason and J. H. Bourque have formed a partnership and opened the Victoria Garage. They will conduct a general motor sales and repair business.

**ST. JOHN, N.B.**—The partnership between R. J. Ritchie, S. J. Ritchie, F. S. Ritchie and Annie J. Ritchie, under the name of Great Eastern Garage has been dissolved. An incorporated company will continue the business under the name of the Great Eastern Garage Company.

**TRURO.**—A committee consisting of Mr. Bradt of Fredericton, secretary for agriculture for New Brunswick; Hon. Mr. Lee, Minister of Agriculture in P.E.I. Government, and Dr. Melville Cumming, of Truro, recently presented a petition to the Federal Government for a maritime dairy school.

### QUEBEC

**ST. JOHN'S.**—The Canadian Hart Accumulator Co., Limited, has completed an addition to their factory which has more than doubled their capacity.

**MONTREAL.**—A new concern, the Tractor and Implement Company, Limited, with a capital of \$1,000,000, has been formed to manufacture tractors, implements, motor cycles and accessories.

**MONTMAGNY.**—The National Farming Machinery, Limited, has taken over the plant of the General Car and Machinery Works, Limited, and will spend about a million dollars on extensions and new equipment.

### ONTARIO

**HAMILTON.**—A motor show will be held in the armories about the middle of April.

**OTTAWA.**—The Board of Control recently asked for tenders for one ton Ford truck.

**TWEED.**—Le Sage Bros., Gray-Dort dealers, have taken over the garage formerly occupied by J. D. Reeves.

**STRATFORD.**—The City Council has decided to purchase a gasoline tractor and a light duty motor truck and are asking for tenders.

**SMITH'S FALLS.**—W. F. Tye has taken on the agency for Massey-Harris implements. He handles all kinds of farm machinery and repairs.

**PICTON.**—Prince Edward County Council recently passed a by-law providing for the expenditure of \$100,000 upon Provincial and county roads during 1920.

**WOODSTOCK.**—The Oxford County Council will provide a large tractor at a cost of \$1,170, also a Ford motor truck at \$960, to be used in county road construction.

**GUELPH.**—The Commerce Motor Trucks, Limited, is the latest industry to locate here. Dominion charter is being applied for and work on the new factory will begin immediately.

**WINGHAM.**—W. Gannett, implement dealer, has purchased from G. Shaw the livery stable building on Josephine street and will immediately occupy the same with his full line of implements.

### MANITOBA

**WINNIPEG.**—Ford dealers and service men from all over Manitoba and Saskatchewan to the number of 300 met in convention recently in the Fort Garry Hotel.

**WINNIPEG.**—The F. B. Goodrich Company of Toronto has opened a distributing branch under the management of R. A. Truck at 44 Princess Street.

**WINNIPEG.**—A policy of development has been determined upon by the greater Winnipeg water district. Tenders are being called for railway equipment for the line to Shoal Lake, and also for motor trucks.

**WINNIPEG.**—Announcement is made of the opening of a garage and repair department by the Grey-Ogletree Motor Company at 297 Burnell Street. The garage is 1,400 square feet and is equipped to handle any job.

### SASKATCHEWAN

**NOKOMIS.**—An implement and automobile business has been formed by Messrs. Fitch and McKay.

**REGINA.**—R. A. Bridgman, I.H.C. assistant manager at Saskatoon has been transferred to a similar post at Regina.

**SASKATOON.**—A. W. Pierson, formerly I. H. C. blockman at Edmonton, has been appointed assistant manager at Saskatoon.

**REGINA.**—Harle Bros. have purchased the implement and hardware business of Messrs. Edwards and King, 1725 Halifax Street.

### ALBERTA

**BASSANO.**—A new concern, known as the United Electric and Engine Co., has been formed here.

**EDMONTON.**—The partnership between Messrs. McConnell and Baris in the Market Tire Repair Shop, has been dissolved.

**BASHAW.**—Messrs. Wells and Brown have opened a warehouse and garage and will deal in tractors and auto repairs.

**EDMONTON.**—Cockshutt Plow Company are clearing the ground on their property here for the erection of a new warehouse.

**EDMONTON.**—C. W. Lockard, formerly I. H. C. assistant manager at Lethbridge, has been transferred in a similar capacity to Edmonton.

**CALGARY.**—W. G. McMaken, formerly International Harvester Company blockman at Lethbridge, has been appointed assistant to manager at Calgary.

**EDMONTON.**—The Massey-Harris Company have purchased six lots, 300 x150 feet, at the corner of 106st Street and Peace Avenue for the purpose of erecting a large warehouse.

### BRITISH COLUMBIA

**NEW WESTMINSTER.**—McIntosh and Bryce have purchased the Columbia Garage.

**CLOVERDALE.**—Messrs. Scott and Lawrence, of Halls Prairie, are building a new garage.

**KAMLOOPS.**—Messrs. Cook and Gerow have opened a new repair garage on Main Street.

**NEW WESTMINSTER.**—The Service Garage is now located in the premises formerly occupied by the Valley Motor Company.

**NEW WESTMINSTER.**—The Valley Motor Company has removed from Columbia Street to the corner of Carnarvan and Lome Streets.

**VANCOUVER.**—The Western Auto Accessories Co. are opening up at 1275 Granville Street. They carry a large line of popular automobile specialties.

**VICTORIA.**—Jameson and Wills, automobile dealers, have installed a Visible Gasoline Pump, manufactured by Phillips and Sons, Kitchener, Ont.

**VICTORIA.**—The Rivercomb Motor Company, distributors for Grant "6," and Federal motor trucks, are building an addition to their premises to be ready in May.



# TURNER Simplicity

Leave a good name behind at every sale

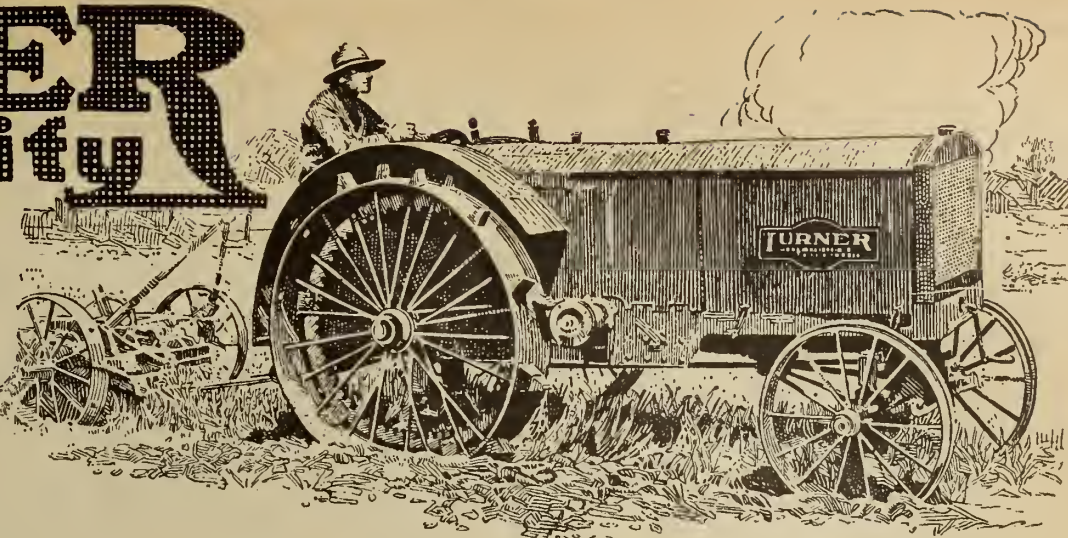

No matter where you sell a Turner Simplicity Tractor, nor for what kind of farm job, you can go back at any time and find it satisfactory. The longer your customer uses it, the more he is going to boost you.

That is why the best distributors, all over this country and Canada, are pinning their faith to it. It is the thing that has made the Turner Tractor break all speed records for sales increase in the past two years.

Surplus power without excessive weight, quick moving, quick turning, adaptability to all kinds of belt jobs, kerosene or gas burning, thorough protection from dust, these and dozens of other qualities are responsible for this smashing sales record

Get all the facts before sales arrangements are made for your locality. Write or wire today

Turner Manufacturing Co., 441 Lake Street, Port Washington, Wisconsin

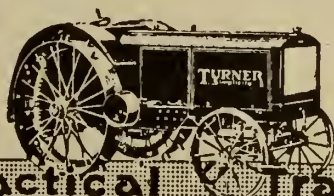

The Practical Tractor

## HELLO, MR. IMPLEMENT MAN!

### "Johnny-on-the-Spot"

is the lowest priced "Quality" small engine in Canada.

—has the largest sale of any engine of the same size in Canada.

—will bring you "repeat" orders and boost your engine sales on all sizes

—will make you the most money and the leading "Power Merchant" in your territory.

GET OUR PROPOSITION TO-DAY.

FILL IN AND RETURN TO-DAY!

Send me your proposition

Name .....

Address .....

"Johnny-on-the-Spot" The Universal Small Engine

1 $\frac{3}{4}$  and 2 $\frac{1}{4}$  h.p.

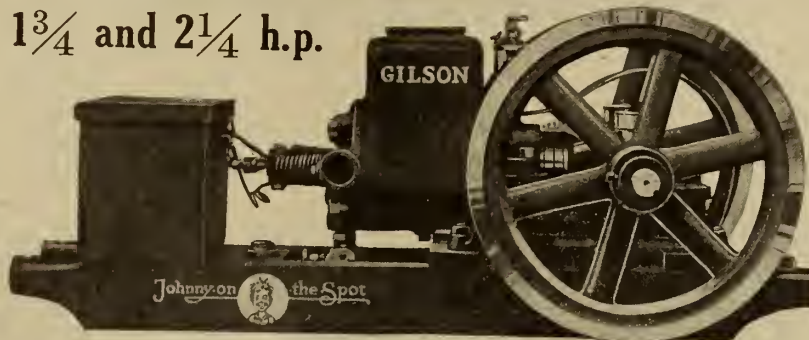

Made in Canada

GILSON MFG. CO., LIMITED

### RETAIL PRICES

1 $\frac{3}{4}$  J.O.S. \$88.50

2 $\frac{1}{4}$  J.O.S. \$108.50

and Big Commissions!

This is your opportunity to make big money—don't fail to grasp it! Our wonderful money-making proposition is ready for you. Get a piece of paper and pencil and write us! AND DO IT NOW!

GET OUR PROPOSITION TO-DAY.

Factory and Office:

18100 York Street, Guelph, Ontario

Branch and Warehouse:

28100 Elgin Avenue, Winnipeg

WE GIVE

## "Quality and Service"

IN

TRACTOR and TRUCK  
STEEL CASTINGS

JOLIETTE STEEL CO., LIMITED

903 Read Building, Montreal

JOLIETTE, P.Q.

THE COMMERCIAL CREDIT COMPANY OF CANADA LIMITED

IS

A CANADIAN COMPANY offering service of interest to and in the interest of Canadians.

Time payments made possible and profitable for Manufacturer, Dealer and Customer. Of particular interest to Automobile and Musical Instrument Trades.

LET US KNOW YOUR REQUIREMENTS

THE COMMERCIAL CREDIT COMPANY OF CANADA LIMITED

Bank of Hamilton Building, Toronto, Ontario

McArthur Building, Winnipeg, Man.



## WILL DUTY BE REMOVED?

WILL the high duty imposed by the Canadian Government upon the importation of motorcycles into Canada, be removed?

Such is the hope expressed by the two representatives of the Handee Manufacturing Company, of Springfield, Mass., who were in Ottawa recently, and who had an interview with the Government upon the subject of duty on motorcycles. The duty on motorcycles is identically the same as that imposed on the importation of automobiles, and it is pointed out by the representatives of the Handee Company that this duty is particularly high, in view of the fact that there are no motorcycle industries in Canada, and that consequently no competition could arise from the carrying on of business in Canada by an outside firm. The only apparent result of the maintenance of the high duty would be the obligation placed upon the Canadian people to pay an excessive and unnecessarily high price for motorcycles.

While no definite stand has been taken on the matter by the Canadian Government, the representatives of the Handee Company have hopes that the tariff barrier will be removed for the season of 1921, and that as a result motorcycles may be purchased at a reduction of 25 per cent. on the present price.

## NEW J. I. CASE BRANCH

THE J. I. Case Threshing Machine Company, Inc., Racine, Wisconsin, has just opened a branch at 345-9 Dufferin Street, Toronto, Ontario. Mr. A. H. Alfsen is Branch Manager with a competent force of assistants to take care of the wants and needs of purchasers of Case machinery.

For the past few years the company's products were offered for sale in Eastern Canada by a well-known distributor, but the company has de-

ecided that, for the best interests of the farmer, the dealer and itself, a factory branch should be established in some suitable distributing centre and Toronto was selected as the logical point.

The company will carry a complete line of its power farming machinery, also attachments, repair parts and supplies on hand at the Toronto Branch together with a competent service force to take care of past, present and future purchasers of Case machinery.

The opening of the Toronto branch will be a great convenience to dealers and farmers who will be within comparatively easy reach of direct factory representation.

## ELECT OFFICERS

THE Toronto Automobile Trade Association, Limited, recently elected the following directors and officers for 1920:

## Directors

W. J. Bedwell, G. E. Gooderham & Co., 97-105 Richmond St. W.; R. C. Kilgour, Ontario Motor Car Co., Ltd., 18 Bloor St. East; G. M. MacWilliam, Hyslop Brothers, Limited, 12-20 Shuter St.; C. M. Ricketts, McLaughlin Motor Car Co., Ltd., 128 Church St.; H. D. Scully, Willys-Overland Limited, 100 Richmond St. W.; Arthur Sharpe, Wolseley Motors Limited, 81 Avenue Road; A. M. Thompson, Dominion Automobile Co., Ltd., 150 Bay Street.

## Officers

G. M. MacWilliam, President, Hyslop Brothers, Limited, 12-20 Shuter St.; A. M. Thompson, 1st Vice-President, Dominion Automobile Co., Ltd., 150 Bay St.; R. C. Kilgour, 2nd Vice-President, Ontario Motor Car Co., Ltd., 18 Bloor St. East; W. J. Bedwell, Secretary and Treasurer, G. E. Gooderham & Co., 97-105 Richmond St. W.

## HOW QUICKLY CAN YOU STOP YOUR CAR?

EVERY auto driver should know the average distances in which a car can be brought to a stop easily and without sliding the tires. The following table gives this: 10 miles an hour 9.2 feet; 15 miles, 20.8 feet; 20 miles, 37 feet; 25 miles, 58 feet; 30 miles, 83.3 feet; 35 miles, 113 feet; 40 miles, 148 feet; 50 miles, 231 feet. Few people would speed if they realized fully how impossible it is to stop in a short distance in an emergency.

## CHANGES IN TRAFFIC RULES

BY invitation, representatives of the Ontario Motor League, the Rotary Club, the Board of Trade, the Board of Control and the King Street Merchants' Association, met the Board of Police Commissioners recently and discussed the proposed traffic regulations which come into effect on April 1st. Some minor changes were considered. The by-law is as follows:

"That no vehicles shall stand on any of the following named streets, except for a period of five minutes, between the hour of 4.45 p.m. and 6 p.m., to take on or discharge passengers or load or unload merchandise; and between the hour of 9 a.m. and 4.45 p.m., except for a period not to exceed 30 minutes, except on Yonge Street, King street and Queen street, where vehicles can only stand for 15 minutes, Sundays and legal holidays excepted." Other streets under this rule are: King, Church to York; Adelaide, Church to Sheppard; Richmond, Church to York; Yonge, Front to Dundas; Bay, Wellington to Queen; Wellington, Church to York; Queen, Bond to Simcoe; Victoria, Colborne to Queen; Church, Richmond to Queen; Jordan, Toronto, Lombard, Melinda, and Colborne (except from Scott to Yonge, where no vehicle is permitted to stand.)

## TRACTORS EXCEED AUTOMOBILES

THE number of tractors shipped into Canada from the United States during the first eight months of 1919 exceeded by nearly 1,000 the total number of automobiles and motor trucks shipped. 8,047 tractors were imported by Canada from the States during the period. About 15,000 tractors are now in use in Canada.

## W. E. CHEESE GOING TO OTTAWA

W. E. CHEESE, who has been associated with John Millen & Son, Ltd., Montreal, as salesman, is shortly to become sales manager for the Keyes Supply Company, of Ottawa. Mr. Cheese has been the recipient of a number of appreciations, among these were a cheque from his late employers and a cabinet of silver from his fellow employees.

Bix—I wonder why a Scotchman always says "hae" for "have"? Dix—Possibly it's on account of his thrift. He saves a "v" every time he does it.—*Boston Transcript*.

\* \* \*

He—"The hand that rocks the cradle rules the world."

She—"Then you come in here and rule the world a while. I'm tired."

\* \* \*

"What's your time?" asked the old farmer of the brisk young salesman.

"Twenty minutes after five. What can I do for you?"

"I want them pants," said the farmer, leading the way to the window and pointing to a ticket marked "Given away at 5.20."—*St. Louis Globe-Democrat Merchandiser*.

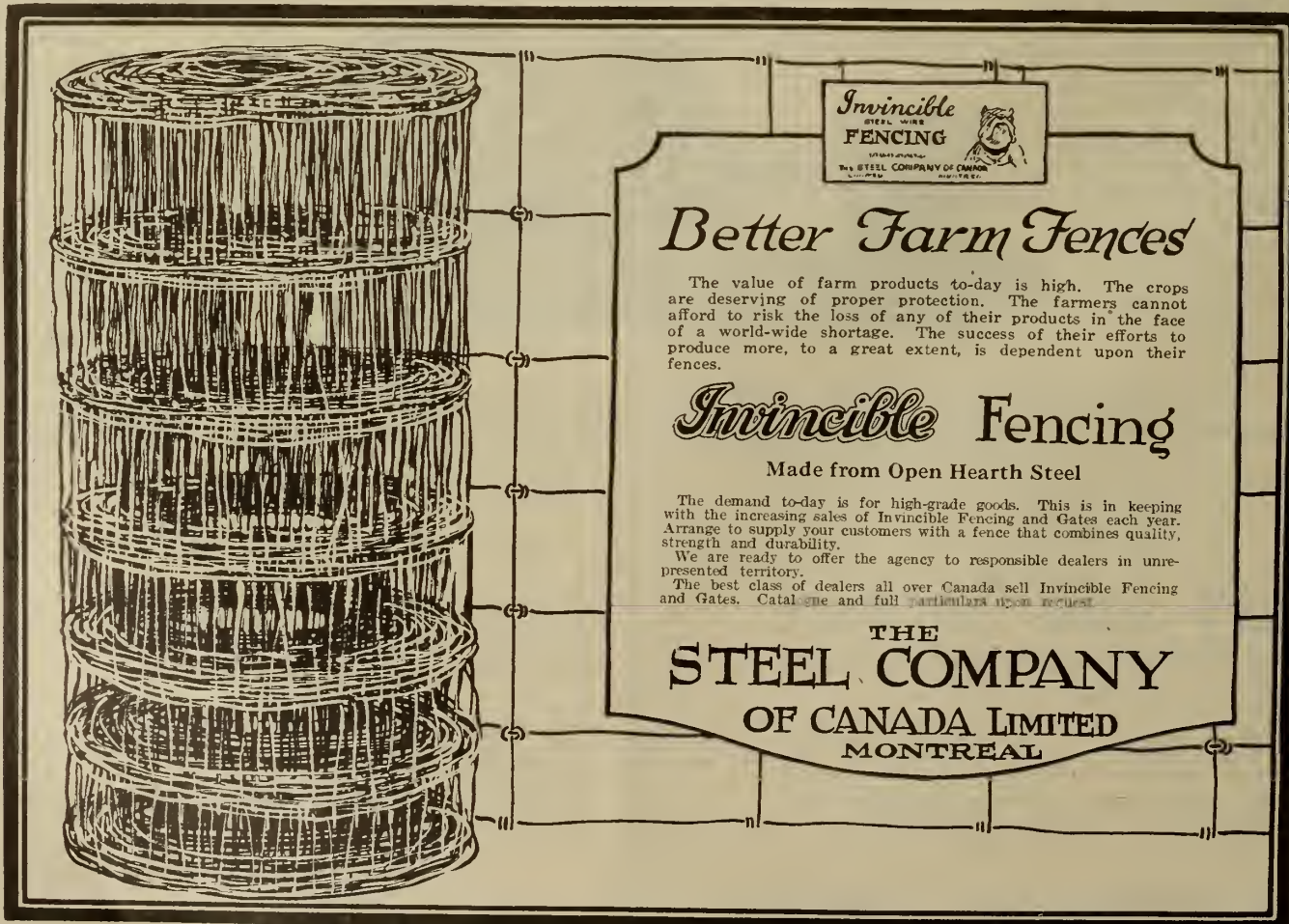

**Invincible**  
STEEL WIRE  
FENCING  
THE STEEL COMPANY OF CANADA  
MONTREAL

*Better Farm Fences*

The value of farm products to-day is high. The crops are deserving of proper protection. The farmers cannot afford to risk the loss of any of their products in the face of a world-wide shortage. The success of their efforts to produce more, to a great extent, is dependent upon their fences.

**Invincible Fencing**

Made from Open Hearth Steel

The demand to-day is for high-grade goods. This is in keeping with the increasing sales of Invincible Fencing and Gates each year. Arrange to supply your customers with a fence that combines quality, strength and durability.

We are ready to offer the agency to responsible dealers in unrepresented territory.

The best class of dealers all over Canada sell Invincible Fencing and Gates. Catalogue and full particulars upon request.

**THE STEEL COMPANY OF CANADA LIMITED**  
MONTREAL



# Tractor or Rattletrap? Make Your Choice

More Noise Than Power when Every Bolt is Loose.

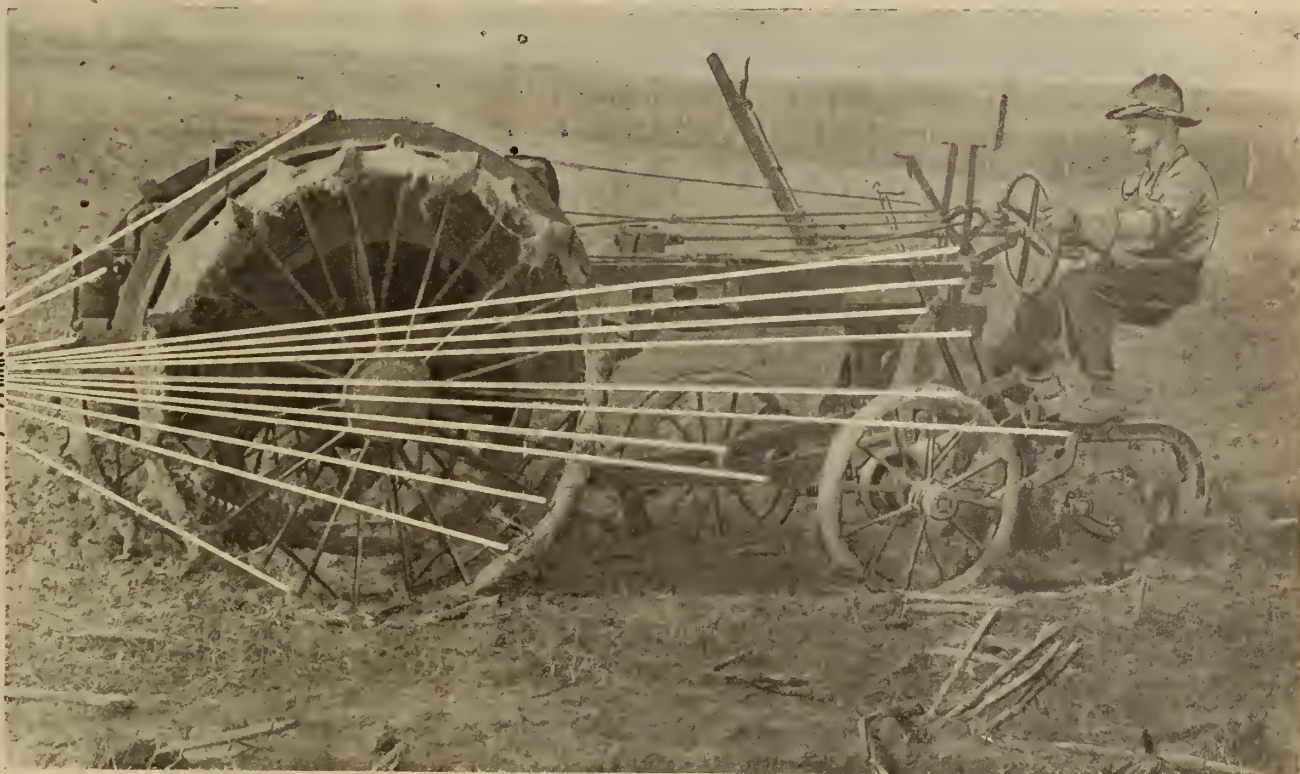

The Nut Lock Turns Rattling Inefficiency into Quiet Driving Force

**Simple Method of Applying**

**FIRST**

Knowing the Size Bolt—  
Use Same Size Nut Lock  
Place Over Bolt — THIS WAY



**SECOND**

Screw Another Nut Down  
Onto Nut Lock and Depress It  
THIS WAY

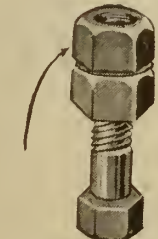

**THIRD**

Remove Second Nut and  
Nut Lock Will Lock  
THIS WAY

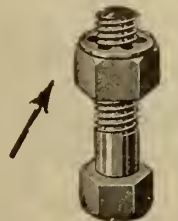

You may own a bundle of loose bolts and call it a tractor; but it's only a rattletrap, a chaos of jangling noise and wasted power.

Unnecessary vibration means loss of power and wearing parts. The parts must hold together to work together. Every grating rattle is the voice of an enemy.

## The Hold Tite Nut Lock

makes each bolt as tight as a rivet, binds the jarring, conflicting parts of a machine into one smoothly co-operating whole, saves wear-and-tear, ends that babel of noise which threatens to break your ear drums, and turns the wasted power of rattle into the efficiency of quiet driving force. The NUT LOCK is a necessity to those who demand maximum efficiency from their tractors.

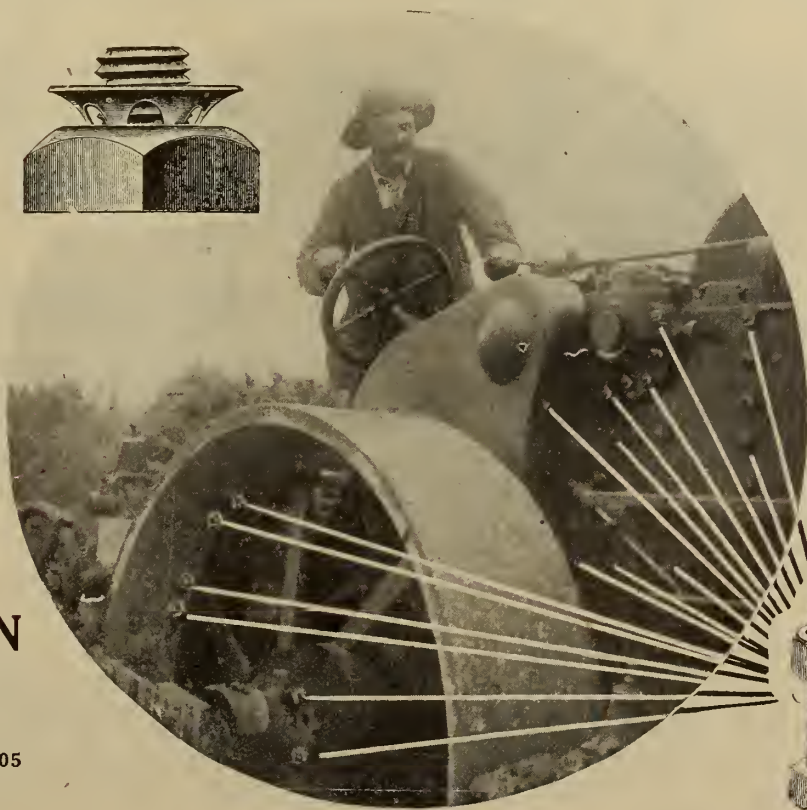
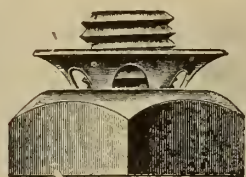

Low in cost because there is no waste material, supreme in efficiency by actual test under the most severe conditions, the Nut Lock is being adopted by manufacturers and sold by dealers everywhere.

Write today for full particulars

**EDWARD A. ROBINSON CO., LIMITED**

228 Craig Street West, Montreal

Canadian Offices: Bank of Toronto Chambers, 205 Yonge Street, Toronto, Ontario

322 McIntyre Block, Winnipeg, Manitoba

American Factory: 166 Montague Street, Brooklyn, N. Y.

**Some of the Satisfied Users of the Hold Tite Nut Lock**

- Steel Co. of Can.
- Jas. Rutherford Co.
- Can. National Rys.
- Renfrew Electric Co.
- Can. Pacific Ry.
- St. Lawrence Sugar Refinery
- Can. Vickers
- Eugene Pattenaude
- A. C. Lariviere
- Ottawa Electric Ry.
- Lowneys, Ltd.
- Can. Axe and Harvest Tools, Ltd.



# The "Essex"



## —TRACTOR—

The agency for Essex Tractors is a big paying proposition for dealers everywhere.

The Essex power and control are two important factors in plowing, 25,000 practical farmers saw the "Essex" 15-30 complete its land first at the Chatham Plowing Competition last fall.

The Essex Tractor Company is an all-Canadian concern making an all-Canadian product.

Write us for FREE LITERATURE and full particulars, also agency proposition.

**Essex Tractor Co., Ltd.**

ESSEX

ONTARIO

## HAYING TOOLS that Need No Introduction

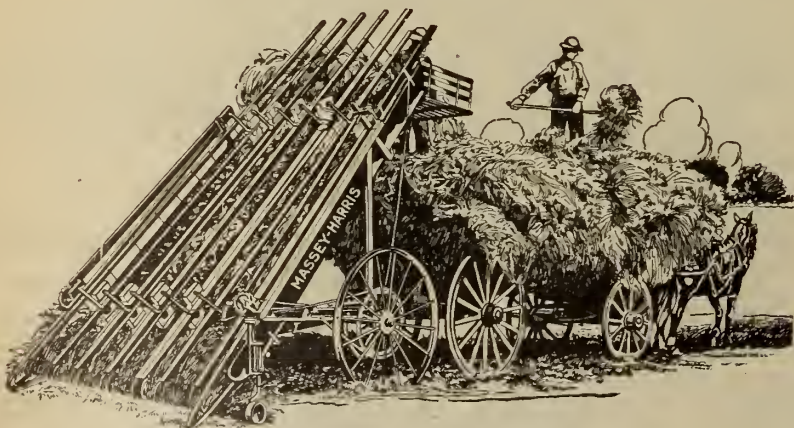

## MASSEY-HARRIS

Known for Generations Back

EVERY farmer is well acquainted with the name Massey-Harris. It's the name on one or more of his machines, and he knows what it stands for in quality and workmanship.

Many Haying Tools will be bought for the coming season—the name Massey-Harris on them is the farmer's best guarantee—and the Agent's easy way to increased sales. *It's the service we give that counts.*

**MASSEY-HARRIS COMPANY, LIMITED**

Head Office - TORONTO, ONT.

Branches at: Montreal, Moncton, Winnipeg, Regina, Saskatoon, Swift Current, Yorkton, Calgary, Edmonton.  
Transfer Houses—Vancouver and Kamloops.



To any Dairy Farmer,  
Anywhere.

Put the Sharples to this test—  
Run skim milk from any  
other separator through  
the only suction-feed  
machine.

Sharples Separator Co.

**T**HIS invitation is extended to all the dairy farmers of the United States and Canada through dairy and agricultural papers of enormous circulation.

The invitation is founded upon actual foreknowledge of the result as has been proven in countless official tests by experiment stations and agricultural colleges.

The Sharples Suction-feed Cream Separator skims clean at any speed. It is the suction-feed principle that enables it to do so and that principle is protected by patents. No other separator can use it.

The knee-low supply tank, the one piece

tubular bowl—no discs to clean—are other exclusive Sharples features.

The separator that gets the most butterfat out of milk is the only one it will pay the thrifty dairyman to buy. It is because we know the Sharples gets more butterfat than any other separator that we ask the prospective buyer to put it to a test that cannot fail.

Dealers having a Sharples contract reap the benefit of the wide advertising of the unanswerable Sharples challenge:— *Skims Clean at any Speed*. They are able to prove to the dairy farmers that it costs less to own a Sharples Suction-feed Cream Separator than it does to be without one.

# Sharples

## SUCTION-FEED CREAM SEPARATOR

THE SHARPLES SEPARATOR CO.

Toronto, Ont.

Montreal, Que. Regina, Sask.



Skims  
clean  
at any  
speed

"The surest way to increase the profit in dairying is to install labor-saving and loss-preventing machinery. And the best machinery will save the most."

—P. M. SHARPLES

"There are no substitutes for dairy foods."



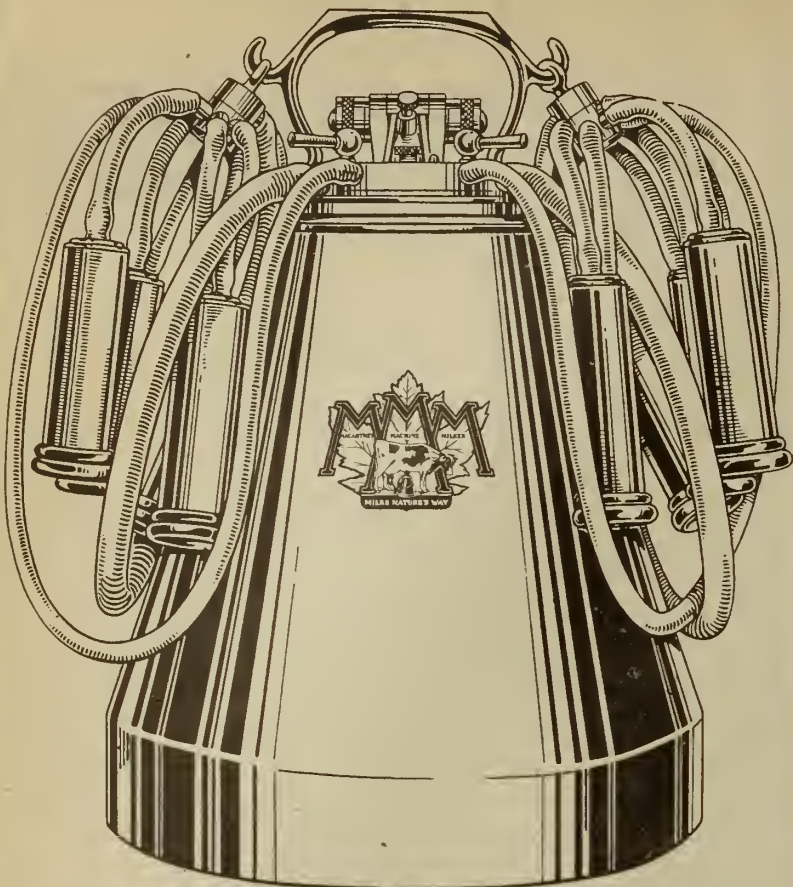

THE COW'S ADOPTED CHILD

## What it means to be a Macartney Machine Milker Agent

You will have the exclusive representation for your territory of a milking machine that has won the unstinted approval of agricultural colleges and the most successful dairy men.

You will have behind you a campaign of real sales making consumer advertising to create the buying impulse in the mind of every farmer and dairy man in your locality.

You will have the absolute assurance of a satisfied customer with every Macartney Milker you sell because the Macartney Machine Milker is a labor-saver and a money-maker that makes better dairy profits assured.

You will have an unusual opportunity to make attractive profits. The Milking Machine market is scarcely touched. One Macartney representative made \$6,000 in 5 months! What he did you can do.

Our terms to dealers are very liberal. May we write you fully about our proposition? Decide to-day. Territories are being closed up everywhere, so act at once if you wish to be with us.

**The Macartney Milking Machine Co.**  
Limited

316 Catherine St. - Ottawa

## Dairy and Household Supplies

### NEW DE LAVAL MILKER

THE new milking machine being placed on the market by the De Laval Separator Company is creating considerable interest among dealers and dairyman. The makers claim for their machine many exclusive features.

Instead of using only one pipeline for both vacuum and pulsations, there is a separate line for each. In the vacuum line a continuous vacuum is maintained, and the impulses which control the action of the udder pulsators pass through the pulsation line. The independent and positive control of the pulsators gives an alternating full period of vacuum and a full period of pressure in each teat-cup. The period of pressure gives the teat a gentle massage, maintaining healthful blood circulation and keeping the teats and udder in perfect condition.

Another important feature is the Udder Pulsator, so named because it is placed within six inches of the udder, instead of being located on pipeline or on top of the pail. The pulsator, being within a few inches of where the work is done, results in quick, snappy action on the teat and fast, thorough milking. No matter how far away from the Pulso-Pump the milking is to be done, the pulsations have the same definite, snappy action, due to a device known as the Pulso-Relay, which is placed at intervals in the vacuum pipe, and which maintains the intensity of the pulsations throughout long lines of stanchions.

The manufacturers claim that the milker requires no adjustments, everything having been worked out with a view to simplicity. There is nothing for the operator to do but to apply the teat-cups to the cow's teats and wash the machine.

The Pulso-Pump is a De Laval invention, which both creates a uniform and continuous vacuum in the vacuum pipeline and produces the pulsations throughout the pulsation line. The accurate and even alternating action whereby milk is drawn alternately from the front and rear teats, is in exact compliance with the cow's method of producing milk, which is continuous. The teat-cups are of a simple but effective type. Only one size is needed for all sizes of teats, and all parts coming in contact with the milk are easily cleaned and the milker is being used in many dairies where certified milk is marketed at advanced prices.

### ADVERTISEMENT WITH A PUNCH!

"PLAY SQUARE WITH YOUR WIFE," is the legend of a washing machine advertisement in an Elkland, Mo., local paper inserted by R. B. Dugan, implement dealer. Following the caption the advertisement reads:

"A man will pay \$225 for a binder, use it 2 days a year; \$65 for a planter, use it 2 days; \$130 for a wheat drill, use it 2 days; and let his wife rub, rub, rub on a washboard all day long 52 to 75 days a year. A power washer will do its work as well as a binder or any other machine."

### SWEDISH APPOINTMENTS

THE Swedish Separator Co., Chicago, recently announced the appointment of C. A. Wood as manager of sales promotion. Mr. Wood was formerly with Swift and Co., Chicago packers. He has had a wide experience in the dairy field.

Another addition to the Swedish Co.'s staff is J. A. Noren as service manager.

### A NEW WASHER

THE Rochester Washing Machine Corp., Rochester, N.Y., are placing on the market an improved washing machine, claiming that it involves new principles and cleans clothes without wear and will also eliminate hard labor. The makers state that their washing machine, with wringer attachment, is built with a roomy cylinder, large enough to handle an entire washing of an average family. The cylinder, which is of wood, revolves 6 times in one direction, and automatically reverses and revolves six times in the opposite direction. This continual action forces the hot suds through the



Electric Washing Machine.

fine meshes of the clothes, incidentally cleaning them, this applying also to laces or blankets.

This machine is said to have been made with an object of eliminating pounding, rubbing or friction, the cylinder being made of white pine in order not to swell, sag, warp or rot. Also so as not to attract the greasy substance which comes from all soapy clothes. The machine is very easy to operate, being started and stopped by one lever, located on the side of the machine, and both machine and wringer may be operated together or individually, as needs may require. A switch attached to the side of the machine controls the motor.

### STUDY THE MILKING MACHINE

THE man who works on the farm and in the dairy accomplishes a lot more than he did in the days gone by. Times have changed, working conditions have changed, and these conditions have been brought about by the application of machinery on the modern farm.

We are living in an age of progress. Most of us have discarded old, inefficient methods. Slower methods have given way to the modern automobile and tractor. Motor trucks are taking the places of horse and wagon. Gasoline and electric power do the pumping on the farm. Cream separators have taken the place of hand skimming—and all because modern methods are better, quicker and accomplish bigger results.

Now comes the perfected milking machine. The slow, laborious method of hand-milking is passing. The day is coming, and coming soon, when every dairyman with ten or more cows is going to do his milking by machine. Implement dealers who wish to sell successfully the milking machine to the dairyman should study its construction and operation and be able to instruct others.



# “The De Laval Agency is one of the good assets of my business”

—Chas. R. Stevenson



Interior view of Chas. R. Stevenson's Store  
(Extract from letter)

“I began selling De Laval Separators in 1908, and have sold on an average of 35 machines per year. I have always found the De Laval Company an excellent firm to do business with, prompt in shipments, and my accounts with them have always been correct to a cent. I consider the De Laval Agency one of the good assets of my business. We have at all times endeavored to give the best service possible—installing the separators and giving full information as to washing, etc. We also endeavor to carry a full line of repairs.”

CHAS. R. STEVENSON,  
CHATHAM, ONT.



There is no better time than right now to send in an application for a De Laval contract. There is more profitable cream separator business with the De Laval than with any other separator

**THE DE LAVAL COMPANY, Ltd.**

MONTREAL PETERBORO WINNIPEG EDMONTON VANCOUVER

50,000 Branches and Local Agencies the World Over



# CANADIAN Motor Tractor and Implement Trade Journal BUYERS DIRECTORY

This directory will help you with your buying and your planning. The advertisers listed here are thoroughly reliable and leaders in their respective fields. They are looking for live, wide-awake representatives. Study their advertisements carefully because they contain valuable information which will dovetail with your plans. We are glad to go to the trouble of arranging this list—to make it easy for you to select new lines. If it so happens that what you want is not here, write us, and we will tell you where to get it.

## ACCESSORIES

Northern Electric Co., Ltd., Montreal.  
G. H. Broughton & Co., Toronto.  
The Goodyear Tire & Rubber Co. of Canada, Ltd., Toronto.  
Apollo Plug Mfg. Co., Birmingham, Eng.  
R. F. Sedgley, Inc., Philadelphia, Pa.  
The Burrowes Mfg. Co., Ltd., Toronto.  
Can. Fairbanks-Morse Co., Ltd., Montreal.  
Kales Stamping Co., Detroit, Mich.  
Kinzing Bruce Co., Niagara Falls, O.  
The Greb Co., Boston.  
Aikenhead Hardware Co., Toronto.  
Hyslop Bros., Toronto.  
Can. Lamp & Stamping Co., Ford, Ont.  
Fyrac Mfg. Co., Rochfort, Ill.  
K. P. Products Co., 250 West 54th St., New York City.  
Perfex Radiator Co., Racine, Wis.  
Robinson Co. Ltd., Edward A., Montreal.

## AUTOMOBILE CHAINS

Can. Fairbanks-Morse Co., Ltd., Montreal.

## BARN EQUIPMENT

Beatty Bros., Ltd., Fergus, Ont.

## BEAN MACHINERY

John Deere Mfg. Co., Welland, Ont.

## BEEF MACHINERY

International Harvester Co., of Can., Ltd., Hamilton, Ont.  
John Deere Mfg. Co., Welland, Ont.

## BINDERS

The Frost & Wood Co., Ltd., Smiths Falls, Ont.  
International Harvester Co., of Can., Ltd., Hamilton, Ont.  
Massey-Harris Co., Toronto.

## BELTING

The Goodyear Tire & Rubber Co. of Canada, Ltd., Toronto.

## BATTERIES

Can. Fairbanks-Morse Co., Ltd., Montreal.

## CARRIAGES

Cockshutt Plow Co., Brantford, Ont.

## CREAM SEPARATORS

De Laval Co., Ltd., Peterboro, Ont.  
International Harvester Co., of Can., Ltd., Hamilton, Ont.  
King Separator Co., Bridgeburg, Ont.  
R. A. Lister Co. (Canada), Ltd., Toronto  
Sharples Separator Co., Toronto.  
Swedish Separator Co., Montreal.

## CEMENT MIXERS

Can. Fairbanks-Morse Co., Ltd., Montreal.

## CASTINGS

Joliette Steel Co., Joliette, P.Q.

## CORN HARVESTERS

Cockshutt Plow Co., Brantford, Ont.  
International Harvester Co., of Can., Ltd., Hamilton, Ont.  
Massey-Harris Co., Toronto.

## CORN MACHINERY

International Harvester Co., of Can., Ltd., Hamilton, Ont.  
John Deere Mfg. Co., Welland, Ont.

## CULTIVATORS

Cockshutt Plow Co., Brantford, Ont.  
John Deere Mfg. Co., Welland, Ont.  
Massey-Harris Co., Toronto.  
The Frost & Wood Co., Ltd., Smiths Falls, Ont.  
International Harvester Co., of Can., Ltd., Hamilton, Ont.

## CUTTERS

Butterfield & Co., Inc., Rock Island, Q.

## DAIRY SUPPLIES

International Harvester Co., of Can., Ltd., Hamilton, Ont.  
R. A. Lister Co. (Canada), Ltd., Toronto  
DeLaval Dairy Supply Co., Peterboro.

## DIES

Butterfield & Co., Inc., Rock Island, Q.

## DISCS

Massey-Harris Co., Toronto.

## DITCHING MACHINES

Can. Fairbanks-Morse Co., Ltd., Montreal.

## DRILLS

Massey-Harris Co., Toronto.

## DRILLS, TWIST

Butterfield & Co., Inc., Rock Island, Q.

## DRILLS, GRAIN

Cockshutt Plow Co., Brantford, Ont.  
International Harvester Co., of Can., Ltd., Hamilton, Ont.  
John Deere Mfg. Co., Welland, Ont.  
The Frost & Wood Co., Ltd., Smiths Falls, Ont.

## ENGINES

Can. Fairbanks-Morse Co., Ltd., Montreal.  
Gilson Mfg. Co., Ltd., Guelph, Ont.  
International Harvester Co., of Can., Ltd., Hamilton, Ont.  
John Deere Mfg. Co., Welland, Ont.  
The Frost & Wood Co., Ltd., Smiths Falls, Ont.  
Massey-Harris Co., Toronto.  
R. A. Lister Co. (Canada), Ltd., Toronto  
Sharples Separator Co., Toronto.

## ENSILAGE CUTTERS

Can. Fairbanks-Morse Co., Ltd., Montreal.  
Gilson Mfg. Co., Guelph, Ont.  
International Harvester Co., of Can., Ltd., Hamilton, Ont.  
Massey-Harris Co., Toronto.

## FEEDERS

John Deere Mfg. Co., Welland, Ont.

## FARM MACHINERY

Can. Fairbanks-Morse Co., Ltd., Montreal.  
Cockshutt Plow Co., Brantford, Ont.  
John Deere Mfg. Co., Welland, Ont.  
International Harvester Co., of Can., Ltd., Hamilton, Ont.  
Massey-Harris Co., Toronto.  
Can. Potato Mch. Co., Galt.  
The Frost & Wood Co., Ltd., Smiths Falls, Ont.  
R. A. Lister Co. (Canada), Ltd., Toronto  
Gilson Engine Co., Guelph, Ont.

## FEED CUTTERS

Can. Fairbanks-Morse Co., Ltd., Montreal.  
Massey-Harris Co., Toronto.  
Gilson Engine Co., Guelph, Ont.

## FENCING

The Steel Company of Canada, Ltd., Montreal, Que.

## FINANCIAL

The Commercial Credit Co. of Canada, Ltd., Toronto.

## GRINDSTONES

S. Vessot & Co., Joliette, P.Q.

## GRINDERS

Can. Fairbanks-Morse Co., Ltd., Montreal.  
International Harvester Co., of Can., Ltd., Hamilton, Ont.  
Massey-Harris Co., Toronto.  
R. A. Lister Co. (Canada), Ltd., Toronto  
S. Vessot & Co., Joliette, P.Q.  
Gilson Engine Co., Guelph, Ont.

## HARROWS

Cockshutt Plow Co., Brantford, Ont.  
International Harvester Co., of Can., Ltd., Hamilton, Ont.  
John Deere Mfg. Co., Welland, Ont.  
Massey-Harris Co., Toronto.  
The Frost & Wood Co., Ltd., Smiths Falls, Ont.

## HAY LOADERS

International Harvester Co., of Can., Ltd., Hamilton, Ont.  
John Deere Mfg. Co., Welland, Ont.  
The Frost & Wood Co., Ltd., Smiths Falls, Ont.

## HARDWARE

Can. Fairbanks-Morse Co., Ltd., Montreal.  
Massey-Harris Co., Toronto.

## HAY RAKES

John Deere Mfg. Co., Welland, Ont.  
The Frost & Wood Co., Ltd., Smiths Falls, Ont.

## HAY CARRIERS

Beatty Bros., Ltd., Fergus, Ont.  
Massey-Harris Co., Toronto.

## HAY PRESSES

Birdsell Mfg. Co., Toronto.  
International Harvester Co., of Can., Ltd., Hamilton, Ont.

## HULLERS (Clover)

Birdsell Mfg. Co., Toronto.

## LIGHTNING RODS

Shinn Mfg. Co., Guelph, Ont.

## LIGHTNING SYSTEMS

Can. Fairbanks-Morse Co., Ltd., Montreal.

R. A. Lister Co. (Canada), Ltd., Toronto  
Northern Electric Co., Ltd., Montreal.  
Gilson Engine Co., Guelph, Ont.

## LIME AND FERTILIZER SOWERS

John Deere Mfg. Co., Welland, Ont.

## MANURE CARRIERS

Beatty Bros., Ltd., Fergus, Ont.

## MANURE SPREADERS

Cockshutt Plow Co., Brantford, Ont.  
International Harvester Co., of Can., Ltd., Hamilton, Ont.  
John Deere Mfg. Co., Welland, Ont.  
Massey-Harris Co., Toronto.  
The Frost & Wood Co., Ltd., Smiths Falls, Ont.  
Gilson Engine Co., Guelph, Ont.

## MARINE FITTINGS

Northern Electric Co., Ltd., Montreal.

## MOWERS

Cockshutt Plow Co., Brantford, Ont.  
International Harvester Co., of Can., Ltd., Hamilton, Ont.  
Massey-Harris Co., Toronto.  
The Frost & Wood Co., Ltd., Smiths Falls, Ont.

## MILKING MACHINES

R. A. Lister Co. (Canada), Ltd., Toronto  
Sharples Separator Co., Toronto.  
The Macartney Milking Machine Co., Ltd., Ottawa, Ont.

## MILLING CUTTERS

Butterfield & Co., Inc., Rock Island, Q.

## NUT LOCKS

Robinson Co., Ltd., Ed. A., Montreal.

## OILS

Imperial Oil Co., Toronto.

## PISTON RINGS

WedgeRite Piston Ring Co., Ltd., Montreal.

## PLOWS

Cockshutt Plow Co., Brantford, Ont.  
John Deere Mfg. Co., Welland, Ont.  
The Frost & Wood Co., Ltd., Smiths Falls, Ont.  
International Harvester Co., of Can., Ltd., Hamilton, Ont.  
Massey-Harris Co., Toronto.

## POLICE AND FIRE ALARM EQUIPMENT

Northern Electric Co., Ltd., Montreal.

## POWER AND LIGHT EQUIPMENT

Northern Electric Co., Ltd., Montreal.

## POWER MACHINERY

Can. Fairbanks-Morse Co., Ltd., Montreal.  
John Deere Mfg. Co., Welland, Ont.  
Massey-Harris Co., Toronto.  
International Harvester Co., of Can., Ltd., Hamilton, Ont.  
Gilson Engine Co., Guelph, Ont.

## POWER SWITCHBOARDS

Northern Electric Co., Ltd., Montreal.

## POTATO MACHINERY

John Deere Mfg. Co., Welland, Ont.  
Cockshutt Plow Co., Brantford, Ont.  
Can. Potato Mch. Co., Galt, Ont.

## PULVERIZERS

Cockshutt Plow Co., Brantford, Ont.  
International Harvester Co., of Can., Ltd., Hamilton, Ont.

## PULPERS

Cockshutt Plow Co., Brantford, Ont.

## RAKES

International Harvester Co., of Can., Ltd., Hamilton, Ont.  
The Frost & Wood Co., Ltd., Smiths Falls, Ont.

## REAPERS

International Harvester Co., of Can., Ltd., Hamilton, Ont.  
The Frost & Wood Co., Ltd., Smiths Falls, Ont.

## REAMERS

Butterfield & Co., Inc., Rock Island, Q.

## ROLLERS

Cockshutt Plow Co., Brantford, Ont.  
Massey-Harris Co., Toronto.  
Hyatt Roller Bearing Co., Chicago.

## ROLLER BEARINGS

Hyatt Roller Bearing Co., Chicago.

## SAFES

J. & J. Taylor, Ltd., Toronto.

## SAW MILL OUTFITS

Massey-Harris Co., Toronto.

## SCUFFLERS

Cockshutt Plow Co., Brantford, Ont.  
International Harvester Co., of Can., Ltd., Hamilton, Ont.  
John Deere Mfg. Co., Welland, Ont.

## SEEDERS

Massey-Harris Co., Toronto.

## SCREW PLATES

Butterfield & Co., Inc., Rock Island, Q.

## STABLE EQUIPMENT

Beatty Bros., Ltd., Fergus, Ont.

## SILOS

Gilson Mfg. Co., Guelph, Ont.

## SLEIGHS

Cockshutt Plow Co., Brantford, Ont.  
International Harvester Co., of Can., Ltd., Hamilton, Ont.

## SILO FILLERS

Gilson Mfg. Co., Guelph, Ont.  
International Harvester Co., of Can., Ltd., Hamilton, Ont.

## SOCKET WRENCHES

R. F. Sedgley, Inc., Philadelphia, Pa.

## SPREADERS, MANURE

Cockshutt Plow Co., Brantford, Ont.  
John Deere Mfg. Co., Welland, Ont.  
International Harvester Co., of Can., Ltd., Hamilton, Ont.  
Massey-Harris Co., Toronto.  
Gilson Mfg. Co., Guelph, Ont.

## SPARK PLUGS

Machine & Stamping Co., Toronto.  
Champion Spark Plug Co., Windsor, O.  
Apollo Plug Mfg. Co., Birmingham, Eng.  
Fyrac Mfg. Co., Rochfort, Ill.

## SPARK PLUG CLEANERS

Champion Spark Plug Co., Windsor, O.

## TELEPHONE APPARATUS

Northern Electric Co., Ltd., Montreal.

## TRACTORS

Advance-Rumely Thresher Co., La Porte, Ind.  
R. A. Lister Co. (Canada), Ltd., Toronto  
Can. Allis-Chalmers, Ltd., Toronto.  
Cleveland Tractor Co., Windsor, Ont.  
Gilson Mfg. Co., Guelph, Ont.  
International Harvester Co., of Can., Ltd., Hamilton, Ont.  
J. I. Case Threshing Machine Co., Inc., Racine, Wis.  
Massey-Harris Co., Toronto.  
The Gray Tractor Co. of Canada, Ltd., Winnipeg.  
The Turner Mfg. Co., Port Washington, Wis.  
Essex Tractor Co., Essex, Ont.

## TRACTOR PLOWS

Cockshutt Plow Co., Brantford, Ont.  
International Harvester Co., of Can., Ltd., Hamilton, Ont.  
John Deere Mfg. Co., Welland, Ont.  
Massey-Harris Co., Toronto.

## THRESHERS

Can. Fairbanks-Morse Co., Ltd., Montreal.  
International Harvester Co., of Can., Ltd., Hamilton, Ont.  
J. I. Case Threshing Machine Co., Inc., Racine, Wis.  
R. A. Lister Co. (Canada), Ltd., Toronto  
Gilson Mfg. Co., Guelph, Ont.

## THREAD CUTTING TAPS

Butterfield & Co., Inc., Rock Island, Q.

## TWIST DRILLS

Butterfield & Co., Inc., Rock Island, Q.

## TRUCKS

Beaver Truck Builders, Ltd., Hamilton  
Eastern Canada Motor Truck Co., Ltd., Hull, P.Q.  
International Harvester Co., of Can., Ltd., Hamilton, Ont.

## WHEELBARROWS

Cockshutt Plow Co., Brantford, Ont.  
Massey-Harris Co., Toronto.

## WAGONS

Cockshutt Plow Co., Brantford, Ont.  
International Harvester Co., of Can., Ltd., Hamilton, Ont.  
Massey-Harris Co., Toronto.

## WATER BOWLS

Beatty Bros., Ltd., Fergus, Ont.

## WEEDERS

Cockshutt Plow Co., Brantford, Ont.

## WIRES AND CABLES

Northern Electric Co., Ltd., Montreal.



# Butterfield

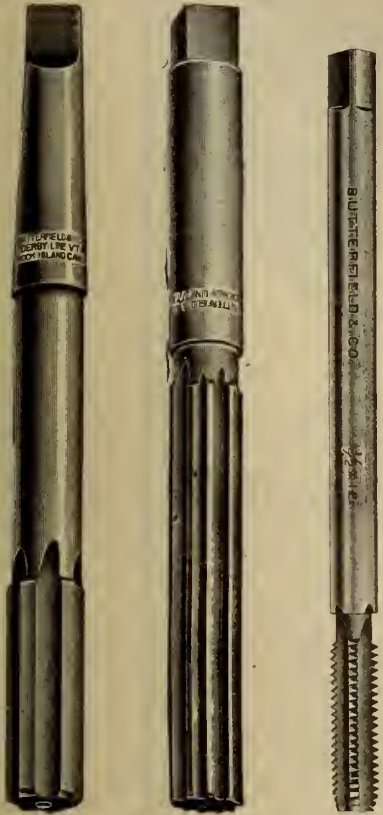

The true test of the quality of Butterfield Tools is their accuracy after long usage.

Try them and you soon will be convinced that they play an important part in keeping down the overhead in repairs.

**Tools That Retain  
Their Keen Edges  
After Long Usage**

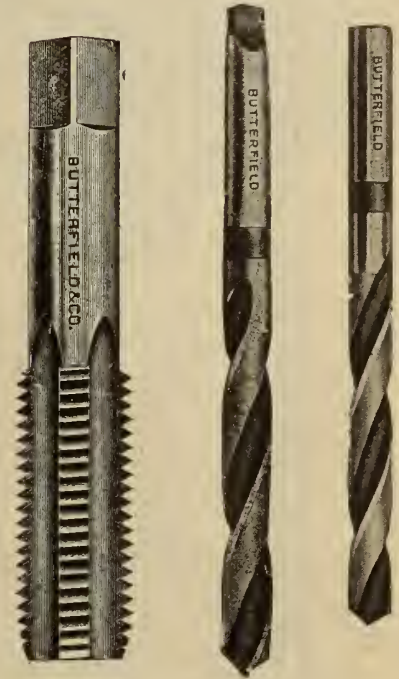

## Drills, Taps, Dies, Reamers

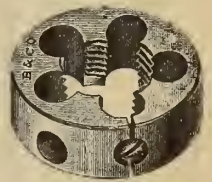

and MILLING CUTTERS

The use of high quality tools on repair work is one of the essentials to the highest-class job, and Butterfield Quality is the BEST.

Every nickel you save in tool service, adds another nickel to your profit on repair work. May we send you our catalogue?

**BUTTERFIELD & CO., INC., ROCK ISLAND, P.Q.**

TORONTO OFFICE: 220 King St. W.



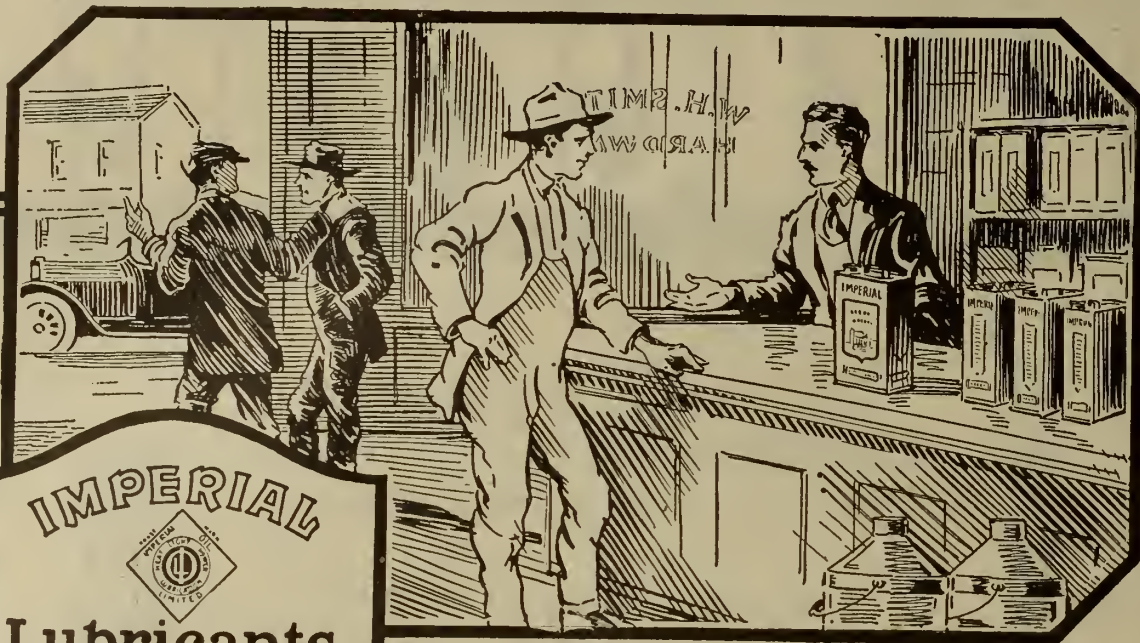

**IMPERIAL**



## Lubricants

**IMPERIAL POLARINE AND  
IMPERIAL POLARINE HEAVY**  
For all gasoline-burning engines—  
automobiles, tractors and trucks.

**IMPERIAL POLARINE A**  
For all motors requiring an un-  
usually heavy oil.

**IMPERIAL POLARINE  
KEROSENE TRACTOR OIL  
AND IMPERIAL POLARINE  
KEROSENE TRACTOR OIL  
EXTRA HEAVY**

For kerosene-burning stationary  
engines and tractors.

**IMPERIAL PRAIRIE  
HARVESTER OIL**

A heavy-bodied oil for open bear-  
ings of threshers, binders and sep-  
arators.

**IMPERIAL ELDORADO  
CASTOR MACHINE OIL**

A thick oil for worn and loose  
bearings.

**IMPERIAL CAPITOL  
CYLINDER OIL**

For steam cylinder lubrication—  
tractors and stationary engines.

**IMPERIAL STANDARD  
GAS ENGINE OIL**

For stationary and portable engines  
using either kerosene or gasoline

**IMPERIAL ARCTIC  
CUP GREASE**

Made in different consistencies.

Imperial Farm Lubricants are for  
sale in  $\frac{1}{2}$ , 1 and 4 gallon sealed  
cans, half-barrels and barrels.

## “Oil Headquarters” is “Farmer’s Headquarters”

**W**HEN the farmer comes to town he naturally calls on  
“Oil Headquarters” for new supplies, and “Oil Head-  
quarters” usually means the dealer who carries a full stock  
and complete line of Imperial Farm Lubricants.

Continuous advertising, year after year, has induced  
thousands of farmers to try these oils and greases, and  
quality alone has increased their sales enormously. Prac-  
tically every farm paper in Canada is carrying Imperial  
Farm Lubricants advertising this year.

Imperial Farm Lubricants are good oils to sell—there is  
a grade specially suited for every farm lubricating need—  
see the list below.

Are you prepared to supply the requirements of the farmers  
in your territory—have you all sizes and all grades in  
sufficient quantities? The farm lubricating business in  
your territory is growing every day with an ever increasing  
ownership of motor cars, motor trucks, tractors, stationary  
gas engines, farm lighting plants, threshing outfits, etc., and  
is a *profitable business*.

Ask the Imperial Oil man about our selling helps.

# IMPERIAL OIL LIMITED

Power · Heat · Light · Lubrication  
Branches in all Cities





# Beaver Trucks

*"Built For Business"*

**Built in Canada's Largest  
Exclusive Truck Factory**

**UNQUESTIONABLY  
"CANADA'S LOWEST HAULING COST"**

Some open territory still available—Catalogues and further information furnished responsible dealers upon request.

**Beaver Truck Builders, Limited**  
HAMILTON, ONTARIO



# VETERAN MOTOR TRUCKS

*Made in Canada*

## POWER, LOW UPKEEP, LONG LIFE

This combination interests the man who has freight to haul

### Why We Use the Ross Steering Gear

**BECAUSE**—The ultimate satisfaction of a driver in a car is not only obtained through the smooth running of the chassis, the power and flexibility of the motor, but also in the steering gear. A poor steering gear expends a great deal of human energy and strength. While on the other hand a good steering gear conserves strength, increases efficiency and means a bigger day's work easily done. Ross Gears are distinguished from all others by the screw and nut mechanism which transfers the rotation of the steering wheel to the steering arm. A solid nut completely envelops the screw so that the entire bearing surface of the threads of both screw and nut are utilized. These large bearing surfaces not only make steering easy under all conditions, but they guarantee an unusual degree of safety and reliability.

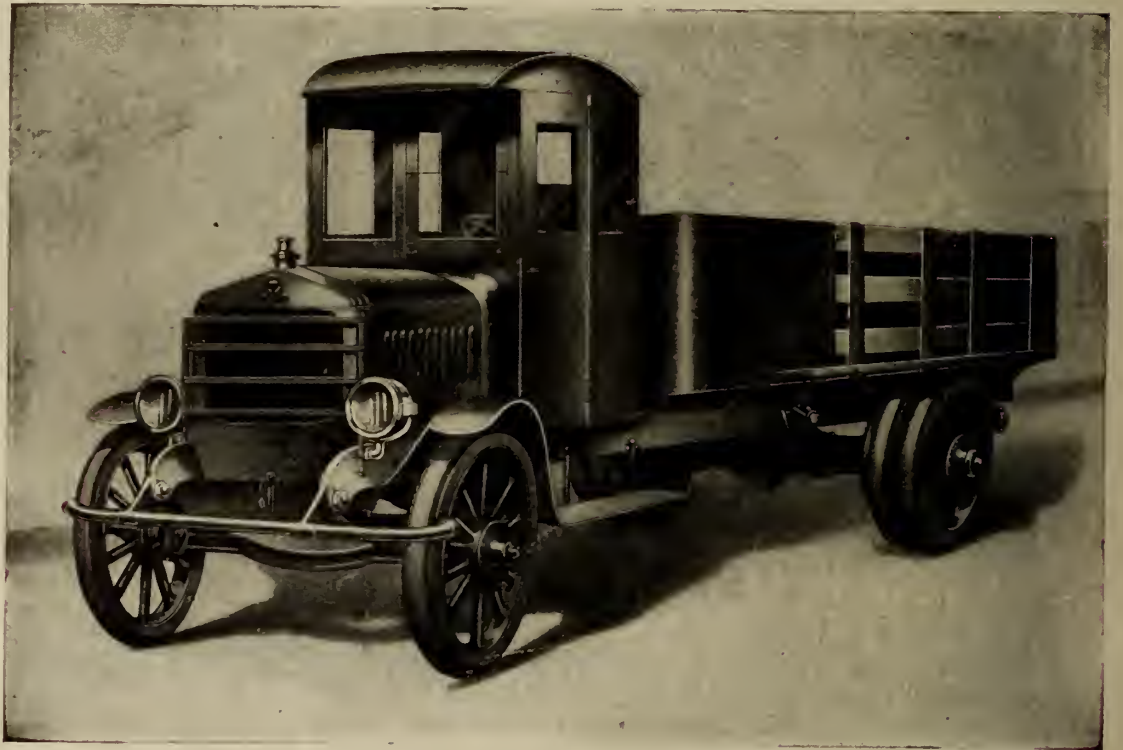

2-1/2 Ton Model Complete with Cab and Stake Body

### Why We Use Oil-less Bushings

**BECAUSE**—A driver will not lie on his back underneath the chassis and "pull up" grease cups; it is a dirty job for any man. The car which has numerous inaccessible grease cups is usually a neglected one. We have therefore eliminated, without decreasing mechanical efficiency, all unexposed cups. These have been replaced with graphite and bronze oil-less bushings. On the bearing surface of the bushing there are cast symmetrical grooves or trenches, varying in design according to the service the bushing is intended. By means of hydraulic pressure these grooves are packed solid with a special fine, hard, lubricating graphite. Once the bushings are in use fine particles of the graphite lubricant are distributed over their entire bearing surface. There is sufficient lubricant in each bushing to last as long as the bushing itself. The graphite and bronze surfaces are flush; they wear evenly; they require no refilling.

### A Short Treatise on the Frame

In the construction of our frame we have incorporated many ideas which have been the result of our invaluable experience of service in the field.

In the first place the frame is bolted, not riveted. The bolts are held in position by lock nuts and washers. There is no fear of popping rivets, common to the ordinary, every-day chassis.

The side members are made out of 6-in. rolled channel and are straight throughout. There are no insweeps or curves. Should the truck meet with an accident, the rolled channel may be straightened with better results than the pressed steel and the lack of curves signifies that the frame can be realigned at less cost, with greater accuracy and in less time than the fabricated pressed steel frame. The cross members are provided with particularly large gussets which insure the frame being kept in alignment under the most severe strains and stresses which can be imposed upon it. The diagonal braces at the rear insure it against distortion. The nose piece which carries the front cross member, side member, front spring bracket and bumper, is of our own design and of unique and sturdy construction. It is the result of practical effort and engineering knowledge. The stress diagram for the frame was worked out mathematically before bolt holes were located, insuring maximum strength to the chassis. In brief the frame is the acme of strength coupled with flexibility.

### Castings

All castings on the truck are interchangeable, except the nose piece, which is slightly inset to take the front spring.

This is the third of a series of advertisements running in this paper explaining more or less in detail the make-up of the Veteran. Copies of previous ads on request.

# Eastern Canada Motor Truck Co., Limited

## HULL, QUE.



# CANADIAN MOTOR, TRACTOR AND IMPLEMENT TRADE JOURNAL

Published Monthly by THE MACLEAN PUBLISHING COMPANY, LIMITED, TORONTO

MONTREAL, Southam Bldg.

WINNIPEG, 1103 Union Trust Bldg.  
NEW YORK, 1133 Broadway.

VANCOUVER, 314 Carter-Cotton Bldg., 198 Hastings St. W.  
BOSTON, 734 Old South Bldg. CHICAGO, 1401-2 Lytton Bldg.

LONDON, ENG., 88 Fleet St., E.C. 4

VOL. II, No. 5

TORONTO, MAY, 1920

Subscription Price  
\$1.00 Per Year

## 3 Big Facts That Help to Sell Monarch Neverslip Tractors

The tractor salesman who is interesting a prospect in the Monarch Neverslip 30-18 is never at a loss for good, sound sales arguments. The creeper type of tractor is so obviously superior to the round wheel type, the mobility of the Monarch Neverslip is so much greater, its construction is of the same quality as a high-grade motor truck, it does not pack down the soil, it is economical—and so on.

There are a hundred and one business reasons for buying the Monarch Neverslip in preference to all others—but—here are three big reasons that should be emphasized to every prospect:

1.—The Monarch Neverslip lays its own tracks. It has always a smooth firm road on which to travel. It utilizes tractor power to its full efficiency on any kind of soil or road, there is no waste power;

2.—With all its enormous pulling power, the Monarch Neverslip Tractor travels lightly over the soil. The 30-18 model exerts a pressure of only 4.6 pounds per square inch—one-third the pressure exerted by a man walking. It will not pack the soil;

3.—The Monarch Neverslip is easy to handle. The fact that it can be turned completely about in its own length shows how responsive it is to the driver's wishes and how completely he has it under control.

Use every argument the novel construction and unusual principle of operation of the Monarch Neverslip make available—but never fail to use these three big persuaders. You fear no competition when you make these points—no other tractor has them.

Monarch Tractors  
turn a complete  
circle in their own  
length.



## A Wonderful Sales Opportunity

Get the utmost out of your business investment, Sell Monarch Tractors—the acknowledged leaders in their field. They do work the way farmers want it done. Monarchs never fail.

**MONARCH  
NEVER-SLIP  
TRACTORS**

Can be worked all the time on all soils—wet or dry, hard or soft. They lay their own tracks. Their grip is irresistible. They are powerful and absolutely dependable.

The Monarch sales policy is decidedly liberal and profitable. Write for complete details. Arrange your territory.

**MONARCH TRACTORS LIMITED**

BRANTFORD

ONTARIO



## The Mighty Force that Holds the Reins of Power

The finest motor in the world cannot deliver the power which it is otherwise capable of furnishing if there is loss of compression.

To fully protect themselves against loss of compression by their engines, thousands of motorists are utilizing the mighty force of the "Wedge"—by installing WEDGERITE PISTON RINGS.

As the WEDGERITE equipped piston comes up on the compression stroke the impenetrable "wedge" pressure of these remarkable Rings prevents the slightest escape of gas or oil. Result: Perfect compression; 100% generation of power.

Ask your repair man to show you these fuel and tire-saving rings.

# The Wedge Does It

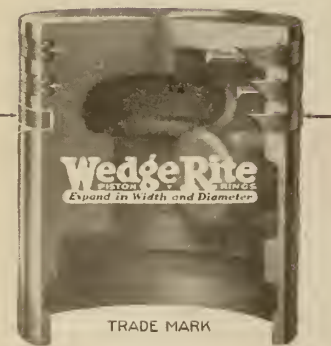
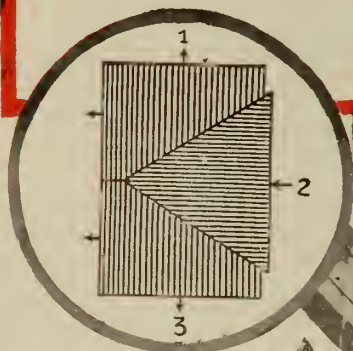

CROSS SECTION OF RING SHOWN IN CIRCLE

- 1—Section pressing outward and upward.
- 2—Spring section of ring.
- 3—Lower outward and downward section.

### ILLUSTRATING THE WEDGE PRINCIPLE

The wedge principle employed in the making of WedgeRite Piston Rings is shown in the accompanying drawing. Its superiority, measured by its ability to expand in WIDTH as well as in diameter, means utmost satisfaction for motorists. The repairman who uses WedgeRite Rings is one who can be trusted. By using the Best Piston Ring he shows a real desire to give you better repair service.

**Wedge Rite**  
 PISTON RING  
 COMPANY  
 LIMITED

92 Notre Dame St. E., Montreal

ORDER FROM YOUR FAVOURITE JOBBER





# AVERY TRACTOR

## has a size for every farm

*The salesman with several choices to offer sells more than the salesman with one or two*

Many a time Avery tractor dealers can point out to the customer a handsome saving of money. The reason is, they can sell him a machine that is pretty close to the quantity of power actually required on the customer's farm. Other tractors are generally too big or too small. Too often a farmer must buy more power than he needs and pay also for the fuel to carry the extra weight around. The difference in cost between a *correct* size Avery and a too-big ordinary tractor closes Avery sales.

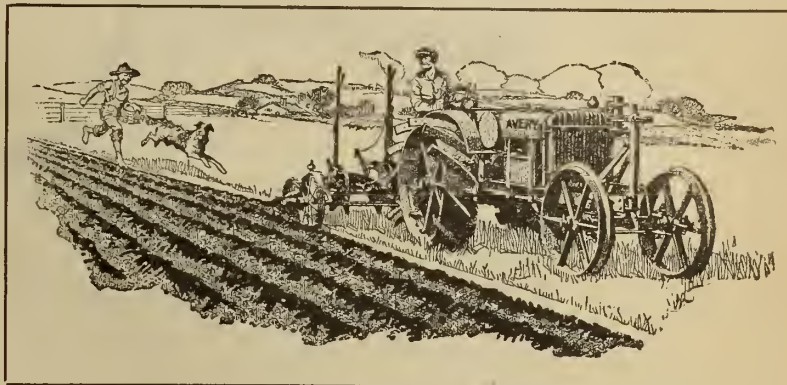

There is a size Avery Tractor for every farm. All sizes from 8-16 h.p. up have a standardized design with every part built specially for tractor use. A man can easily make his own repairs and adjustments—another big selling factor.

Avery Tractors are built for just such conditions as we have in Ontario. It does the work economically and with fewest repairs.

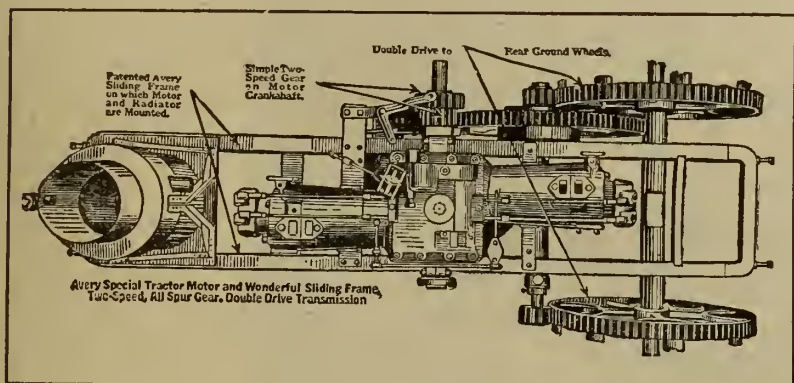

The motor is of the opposed type. Its length distributes the weight best between front and rear wheels. It runs at *lower speed* than other types, thus requiring simpler transmission gears. It also makes possible a "direct drive" in high, low, reverse and on the belt.

Get *all* the particulars about the Avery. Write for free literature and attractive agency proposition.

## The Famous MELOTTE Cream Separator

What the farmers want is the **original** Melotte, sold in Canada only by R. A. Lister & Co., Ltd. By selling the original you can give a complete and satisfactory service in regard to repairs for **ALL** sizes. Besides you sell the original quality separator that made the name "Melotte"

famous for close skimming, easy cleaning and easy running. The separator with the self-balancing bowl, the only ball-bearing bowl on the market. It cannot get out of balance. Simple, durable and **fool-proof**—sells readily on its reputation for efficiency.

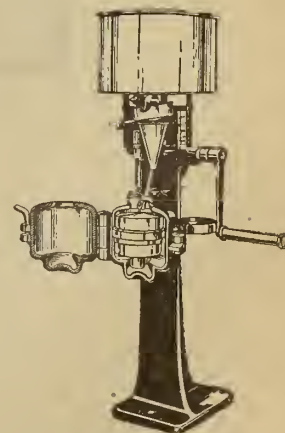

**Other  
Lister  
Lines**

The "Lister" Agency comprises a wide list of farm requirements, all backed up by the Lister reputation for dependability.

Lister Gasoline and Kerosene Engines—Premier Cream Separators  
—Lister Grinders—Lister Milking Machines, Lister Ensilage Cutters,  
Lister Silos, Silo Fillers and Lightning Plants.

## R. A. Lister & Company (Canada) Limited

58-60 Stewart Street, Toronto

Also at Wall St., Winnipeg





Address all Enquiries to

**Canadian Importers Limited**  
Temporary Address  
16 Wellington St. West  
TORONTO

**Italo Canadian Trading Co.**  
720 St. Paul St. West  
MONTREAL

or

**FIAT—501 5th Avenue, New York**



# DEALERS---

Get behind the JOHN DEERE-DAIN LOADER this Spring. Due to its reputation for Quality and Satisfactory Service. They are easy to sell.

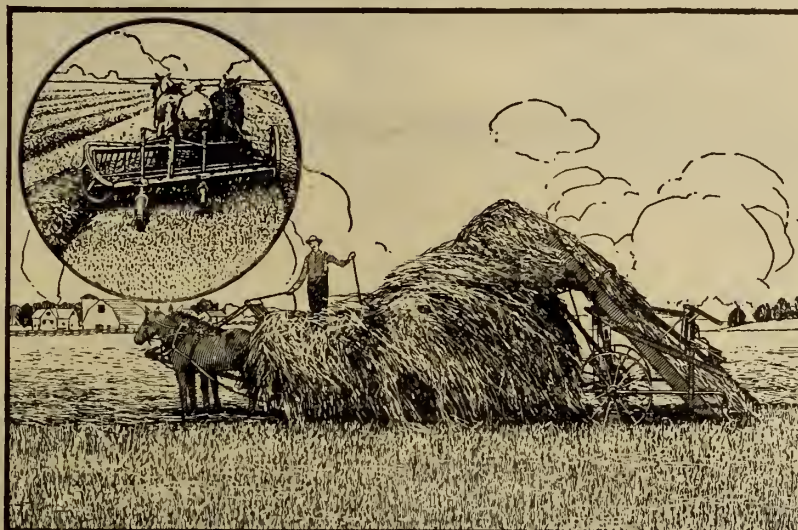

John Deere Advertising will be read by almost every farmer in Ontario.

John Deere Advertising appears in these papers

Canadian Countryman  
Family Herald and Weekly Star

Farm and Dairy  
Farmers' Advocate  
Ottawa Farm Journal

Canadian Farm  
Farmers' Sun  
Farmers' Magazine  
Rural Canada

See that your prospects receive the special booklet "Better Hay—How to Make and Market it"

If you haven't a supply—write us

## SHOW THE FARMER HOW HE CAN *save money and labor.*

by using this Loader. Point out these special features to him and the sale is made.

The John Deere-Dain Loader is a great labor-saver. One man can handle it, thus saving the wages of another man. It is the easiest running and most popular of the rake bar type.

The rear wheels caster—there is no dragging around corners. It is of light draft, roller bearings being used on all main journals.

Its principal working parts are hammock mounted. They swing freely without binding or strain.

Rakes are operated at the right speed to require the least power. The strokes of the rake overlap and thus rake clean. A very desirable feature.

Hay is gathered from the swath the full width of the machine. The change to windrow work is instantly made.

The automatic, adjustable throat opening prevents choking. Hay is delivered to the middle of the load. Elevator adjusts automatically to light and heavy hay.

Coupling is made to high or low wagons without any change.

It is strong, light and durable. It is the original rake bar loader and built with the usual "John Deere" standard of quality and careful workmanship.

If you are not already handling this Loader, write us at once.

**John Deere Implements are sold only by dealers.**  
THE DEALER WHO SELLS JOHN DEERE IMPLEMENTS IS INDEPENDENT

**John Deere Manufacturing Company, Limited WELLAND ONTARIO**



# *The Wonderful Gilson*

MADE IN CANADA



## IT STANDS SUPREME

### REASONS WHY:—

- 1—Your Customers Demand the Gilson—Easy Sales—Big Commissions.
- 2—It has the largest sale of any Silo Filler under the British Flag.
- 3—Its wonderful performance brings repeat orders.
- 4—It is the lightest running blower cutter made.
- 5—Our entire organization is behind you.

## *Frankly Now, Doesn't It Look Good?*

You cannot afford to let this proposition go!

Don't put it off,—write for our special agent's proposition at once.

Tear off, fill in and return the corner of this page. If you don't some one else will.

## IT MEANS DOLLARS TO YOU!

**Gilson Mfg. Co.**  
LIMITED

Factory and Head Office:  
10118 York Street  
GUELPH, ONT.

Branch and Warehouse:  
10128 Elgin Ave.  
WINNIPEG, MAN.

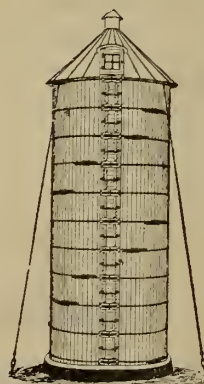

### The Hylo Silo

No farm is complete without the famous Hylo.

**BIG PROFIT—  
EASY SALES**

*Something worth adding to your lines.*

Without any obligation on my part you may send me your agent's proposition on:—  
(Put an X opposite the product that interests you)

Silo  
 Silo Filler  
 Engine  
 Thresher  
 Manure Spreader  
 Tractor

FILL IN AND RETURN AT ONCE  
TEAR OFF HERE

Name .....  
Post Office .....  
R.R. No. .... Prov. ....  
Remarks .....



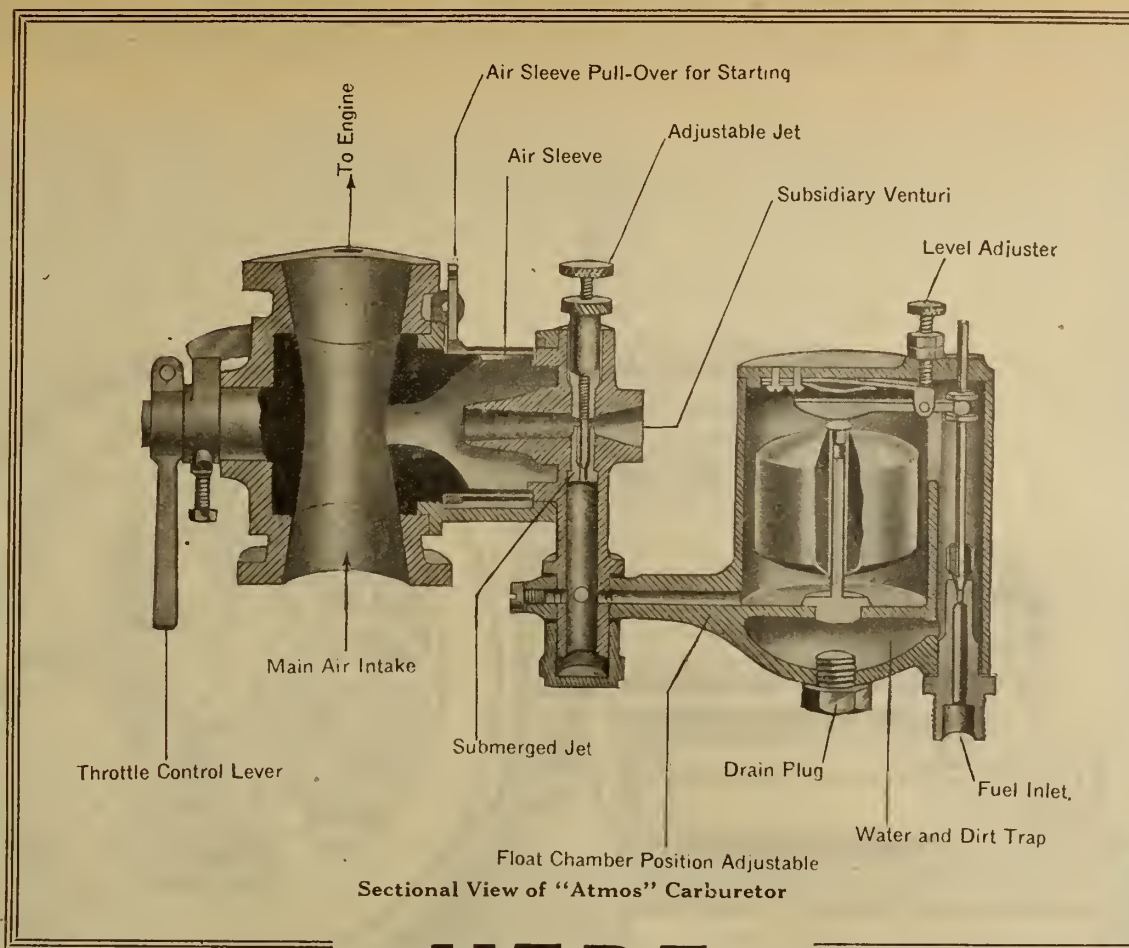

Sectional View of "Atmos" Carburetor

# HERE

## IS A MONEY-MAKER For Accessory Dealers

The Cox "Atmos" Carburetor introduces a new principle of carburetion. Its main features are Simplicity and Economy.

It has but one moving part—one jet, externally adjustable, and no spring controlled valves.

Its simplicity makes it easily adjustable and eliminates trouble from uneven mixtures. This feature alone will sell the

## COX "ATMOS" Carburetor

*Less Fuel*

*More Power*

Its economy is effected by the high degree of atomization it attains. It may be more finely adjusted than other carburetors, making the mixture more economical and yet more volatile. This gives more power with less fuel. The "Atmos" gives great pulling power at low throttle speeds, and eliminates considerable gear shifting in city driving.

Equip your demonstrator with the "Atmos" Carburetor and show your customers its actual performance. That will clinch the sale—and at a good profit to you.

*Write for our dealer proposition.*

Sole Agents in Canada

**BRITISH & FOREIGN AGENCIES**  
LIMITED

17 St. John Street, Montreal, Quebec



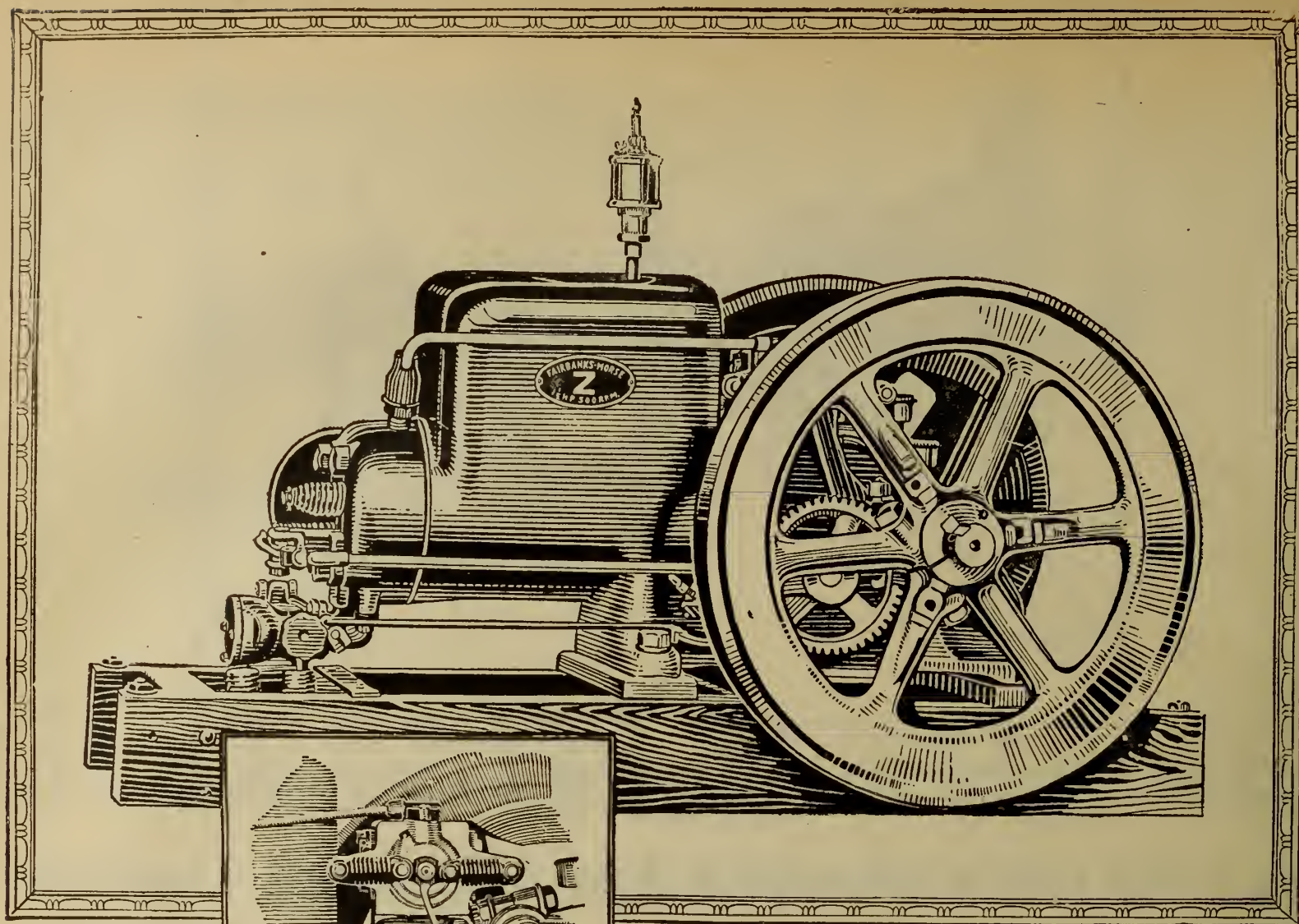

*Fairbanks-Morse  
"Z" Engine with  
Bosch Magneto*

## Now-There is Only One Farm Engine

JUST think of the famous "Z" Engine with a Bosch high-tension, oscillating magneto—which delivers a steady succession of hot, intensive sparks. ¶ Every farmer in Canada should at once call on the nearest "Z" Engine dealer and see the result of this recent epoch-making combination—FAIRBANKS-MORSE "Z" ENGINE WITH BOSCH MAGNETO. ¶ Mechanical perfection, plus power—and right price—to date sold the "Z" Engine to over 250,000 farmers. ¶ This quality and quantity production enabled us to contract for a large proportion of the extensive Bosch facilities for making this one possible "Z" betterment, which establishes a new farm engine standard. ¶ And all Bosch Service Stations throughout Canada will assist our dealers in delivering maximum engine service.

*The Canadian*

MADE IN TORONTO, CANADA BY

47

# Fairbanks-Morse

*Co., Limited.*



HALIFAX

ST. JOHN

QUEBEC

MONTREAL

OTTAWA

TORONTO

HAMILTON

WINDSOR

WINNIPEG

SASKATOON

CALGARY

VANCOUVER

VICTORIA



# CANADIAN MOTOR, TRACTOR AND IMPLEMENT TRADE JOURNAL

Volume 2

TORONTO, MAY 5, 1920

Number 5

## Much Profit in Storage Battery Repairing

AT THE present time there is no better paying line of repair work the garage man can take up than that of storage battery repairing, for the reason that it is not overcrowded. The question of cost is not such an important item with the average owner as getting the work done without the necessity of shipping the "thing" away, and putting up with a delay of anything from a week to a month.

You being "on the job" can give him an approximate idea as to the cost of the job; you can save him several days consumed in transportation, the cost of transporting, and the risk of his battery being laid to one side to make room for another job more pressing. Even if you did not save him the actual money to take and fetch the battery back from the city repairman—and there is no reason why you should not, and more than that you should be able to do the job cheaper than the city man for you are not likely to have his "overhead" to contend with—you can save him valuable time in getting him on the road again. This is a big item with most owners and you should PLAY IT BIG when canvassing for this work. Get into this line at once while the "picking is good," for it is growing so fast that all a man needs in order to get the business is to know how to do the job and to do it right. The equipment needed is not a serious item, and the average garage man can get its cost back again in a matter of three months or so.

MOST repairmen appear to be afraid of a storage battery, but it is really the most simple piece of equipment on the car. It is merely three hard rubber jars containing two sets of plates dovetailed together with wood separators between the plates to prevent them touching each other. One set of plates is positive, the other negative, and the thin sheets of corrugated wood act as insulators between the two groups. It is just as important to see that this insulation is good as to see that the insulation on the wires leading from the battery is in good shape. The action of the acid with which the jars are filled, in time partly rots these separators and if they are renewed once every year the battery will last a great deal longer. If they should be allowed to get into such poor shape where a negative and a positive plate touch there will be a dead short-circuit, which in turn will cause the plates to buckle. They will then have to be renewed, as it is impossible to make a good job of straightening them as they are made of a lead composition into which a special paste is forced. When you try to straighten a plate the paste will be loosened and more than likely fall out in places.

THE action of a battery causes a certain portion of this paste to come out of the plate at each charge or discharge, and being heavier than the acid it falls to the bottom of the jar. To prevent this causing a "short" the plate rests on bridges across the bottom of the jar and the paste that falls off the plate goes clear to the bottom of the jar without touching the plates. This is all right for a time, but eventually so much paste comes off the plates that it fills up this false bottom and comes up to the bridges and bottom of the plates, and as it is a conductor it causes a short-circuit which can be de-

By A. M. GLOVER

termined by the fact that a battery will lose its charge while standing overnight and will come up again when running. The only thing to do in a case like this is to take out the groups, clean out the bottom of the jar and, if the separators are in good shape, put them in again. But it is a good plan to put in new separators while you have the groups out, for there is only the cost of the separators extra and this is a small item on battery work.

Of course the best way to get a grounding in the actual work of tearing down and repairing a battery is to attend one of the schools maintained by the manufacturers and if you are taking up the agency for a particular make that manufacturer will be more than pleased to give you the necessary instructions. But if you are not able to go to the factory for this instruction the salesman will be able to give you some useful pointers if you ask him.

Here are a few facts to remember in battery work: When working on the jar or jar covers heat is most essential to prevent breaking; they are very brittle when cold but as soon as they are slightly warmed they become quite soft and pliable.

When heating the covers of a battery with a naked blow pipe flame do not try to do it just after it has come "off charge,"

styles of batteries have a lock nut of lead and a rubber washer on the posts to prevent acid leakage; in this case, of course, it is necessary to remove these before attempting to take off the top.

Some operators prefer to lift out the group complete before trying to remove the jar cover. This is a good plan, for a better hold can be got on it to lift it off.

When buying equipment do not spend too much on your charging plant; if you get something in the way of a two battery outfit, either a rectifier of the magnetic type or a small generator will be ample to start. You can keep it running day and night and will be surprised at the quantity of batteries it can take care of. When you eventually have to buy the big outfit the small one will not be junk, for it can be used at the time when you have not enough to load up the big outfit to capacity.

## Hamilton Motor Show

THE Hamilton Motor Show, which opened on April 19 and closed April 24, was the largest and most successful automotive exhibition ever held in the Province of Ontario, with the exception of the Canadian National Exhibition Motor Show, Toronto.

The show was under the auspices of the Hamilton Automobile Dealers and Allied Industries, and the management was in the hands of G. O. Phillip and G. D. Pequegnat. The exhibition was held in the Armories, and, despite the huge capacity of the building, all the space had been sold within two days of the plan being sent out. Many applications for allotments from all over Canada had to be turned down. A significant feature of the show was the large exhibition of motor trucks, said to be the largest showing ever made in Canada on a single floor. There was an unusually large showing of accessories, some of which were being shown for the first time. There were 67 exhibits divided between automobiles, trucks and accessories. The Hamilton Automobile Club, which is affiliated with the Ontario Motor League, had a booth at the show and conducted a successful campaign for new members. The decision is to make the show an annual affair.

## Invents Stoker

W. H. CHURCH, of Superb, Sask., has invented a new stoker, which, it is said, will revolutionize the work of harvesting in the West. The necessity, in these days of labor and scarcity, of some mechanical means of setting up stooks, led to experiments which resulted in the present machine. The Superb stoker, as it is called, differs entirely from other machines for the same purpose. The machine is attached to the regular binder, and in setting up a stook it operates under its own traction from a trip controlled by the driver of the binder. The machine sets the stooks up in much the same way as a man would. The device is fully protected by patents.



Abbe Gavois, of Raineville, France, driving his 1891 "Panhard." It is still going strong.

for at that time, and for six to twelve hours after, the jar will be full of highly explosive gas and you are just likely to get "splattered" with acid, which is dangerous to the eyes, painful to the skin and ruinous to overalls and clothing. If you are going to do anything to a battery let it stand idle overnight before commencing operations.

The black pitch-like compound which seals the jar covers and holds the jars in the boxes can be softened by the same means and taken out with a narrow pointed chisel, and when the tops are still warm they can in most cases be lifted off the posts. Some



# Unraveling a Few Facts About Twine

By B. J. PAULSON

ANYWAY, there is one commodity that has not increased in price since last year, but, to the contrary, has taken a decided drop. For that, let us be thankful! The Gordian knot in the twine industry has been cut—and twine prices for 1920 have unraveled to the extent of 20 per cent. below last year's prices. And thereby hangs a story:

Back in 1914 Carranza crawled to the top of the boiling pot of revolution in Mexico and wormed himself into the seat of state.

In the State of Yucatan the business of raising sisal fibre, from which the biggest part of binder twine is made, had been going on in spite of the careless warfare that was being waged. The American manufacturers of binder twine had to have sisal and Yucatan supplied it.

In 1915 the Commission Reguladora, a Yucatan State institution, which had been organized in 1912 to maintain the price of sisal at a high level, but which it had not been able to do, fell under control of the Carranza officials in that state, who, in order to make it effective and for the purpose of raising the price of sisal, compelled all sisal producers to sell to it their sisal, forcing out of that state all other buyers. Thereafter the manufacturers of binder twine had to deal exclusively with this Mexican Government organization, which assumed complete control of sisal production in Yucatan, and its sale to manufacturers.

IN 1915 the price of raw sisal fibre was 7 $\frac{3}{4}$  cents per pound to the manufacturers. By 1916 the Commission Reguladora had raised it to 14 $\frac{1}{2}$  cents a pound—and in 1918 it reached the high-water mark of 19 cents! These increases in the price of sisal fibre naturally resulted in proportionately increased costs to the implement dealer and farmer. Those who did not know the facts blamed the manufacturers.

But to-day the manufacturers show where they stand. The Commission Reguladora is no more—and the Yucatan sisal market is again open, permitting competitive buying and selling by all. As a result, the manufacturers are able to produce twine for 1920 at a cost to the Canadian trade of 20 per cent. below last year's prices in spite of greatly increased freight rates, as well as manufacturing costs, such as labor and equipment.

And there is but little chance for a recurrence of the high twine prices of 1918. The leading twine manufacturers, awake to the menace of raw material control by monopolies, such as the Commission Reguladora, hope to prevent a similar condition in the future. Strong efforts are now being made to revive the Reguladora for the purpose of controlling production of sisal and increasing the price. While fibre production remained localized largely in one limited section of the world, as in the case of Yucatan sisal fibre, the manufacturers were helpless and at the mercy of the Commission Reguladora. But to-day they are on the way to achieving independence of any single fibre-producing market.

ONE of the largest manufacturers of binder twine is conducting extensive experiments with American-grown hemp fibre and has perfected machinery for successfully handling the raw hemp. In the spring of 1917 contracts were made with many farmers for growing hemp, seed being furnished by this company. This concern's experimental department developed machines for harvesting and breaking the hemp in order that the cost of production and handling might be greatly reduced. The chief drawback to hemp twine in the past has been the high cost of producing it, as satisfactory methods of harvesting and preparing the fibre for manufacture had not been evolved until the said company's recent experiments.

To-day one may see the hemp harvester and gatherer-binders working in the hemp fields in the United States, busily engaged in the fight to bring down the high cost of twine. A plant has recently been erected and equipped for artificial drying and breaking of hemp for twine manufacture. This is only the beginning.

As a selling proposition, binder twine does not offer great profit to the dealer. In fact, it is sold on a narrower margin than any other product handled by the implement dealer.

And yet, selling good twine is mighty good business for the implement dealer. It is, in a consider-

able measure, a good-will and service feature. A good grain binder will not work satisfactorily with poor binder twine. The dealer makes a good profit on a binder. But if the binder does not work satisfactorily, due to the use of inferior twine, the binder is often blamed, no matter how good it may be—and the dealer loses good-will and future business.

TWINE that is poorly spliced in the process of manufacture or spun unevenly is very likely to have a high percentage of breakage in tying. And broken bundles mean valuable time lost in tying them by hand, not to mention equally valuable grain lost, due to the broken sheaves not being picked up cleanly by the hired harvest hands.

The dealer who safeguards his customers against the losses incidental to the use of inferior twine, is thereby cementing good-will that will serve as solid foundation for future business. It is, therefore, good business for the dealer to sell good twine that will insure satisfactory operation of good binders, in so

far as binding is concerned. Though the margin of profit be comparatively insignificant on the higher grades of twine, the compensation is there just the same—the compensation derived from satisfactory service to the farmer.

Many dealers, however, are so cautious in the matter of handling twine that they frequently have insufficient stocks to meet the harvest demands of the farmers in their communities. These shortages sometimes prove disastrous to the farmer, for without twine his harvest is held up. Because of this fact some of the leading manufacturers maintain large transfer house and supply depots, located conveniently to the principal grain-growing districts, so that rush emergency shipments can be made to almost any locality where a shortage is reported. In 1912 one manufacturer shipped 92 carloads of twine to Western Canada by express, thereby saving a bumper crop that could not have been cut otherwise, because of a shortage of binder twine.

The dealer can help greatly in circumventing the danger of twine shortages, however, by inducing his grain-growing customers to order early. And there is no time like the present to begin.

## A Time to Sow—A Time to Reap

By G. B. WHEELER

THERE is an old saying, that "In the spring a young man's fancy lightly turns to thoughts of love"—and perhaps it would be a good thing for all of us if, in the spring, our fancy and thoughts would take on some of the refreshing freshness of the season. If there is one season more than another when we should be at our best, it is at this time.

Back there at New Year's time we pondered over our business performance of last year and decided we could see some mistakes, and resolved to avoid them this season. We also made certain plans for improving our business. Some of these plans had to do with improving our method of keeping our stock, our books and accounts, the method of displaying goods on our show room floor. These, of course, we have taken care of during the cold, blustery months.

Then we resolved that we were going to revolutionize our canvassing method, and now is the time,

awaiting him at our warehouse or showroom, and that all we ask is that when he is in the market for anything in our line we are going to appreciate the opportunity of placing the merits of our equipment and our quotations before him. We know that many new customers are going to be secured. We are going to know what and when each man in our territory is going to be in need of in our line.

THE order we lose after a fair, square effort to get it doesn't bother so much. We have tried our best (which may not have been any too good, and certainly not good enough in this particular instance).

But what about the order that is placed by a man in our territory, with whose requirements we should be familiar, but because we are asleep at the switch our competitor secures without our competition at all. That is the order that hurts. Eh?



30-60 Fairbanks-Morse Oil Tractor pulling sixteen 14-inch plows in corn stubble at a test. This plow turns over a strip of land 20 feet wide every time it goes down the field.

when the roads are getting in good condition, that out-field work is going to be done more effectively than ever before.

Instead of driving back and forth on the same roads, and wearing out our welcome by calling on the same few customers, and worrying the life out of them until they buy something else from us or from the special salesman we have along, we have resolved, and right now we are going to keep that resolution, that every man living in our territory will know in a general way what we have to sell. He will know that we are sincere in believing that the lines we are offering are good value for the money. He will know that he has a hearty welcome

The farmer is busy preparing the ground, planting the seed, all with the expectation of a harvest-home later on. He would be a foolish farmer who would expect to enjoy the harvest who didn't put forth the necessary effort at seed time.

Business of selling is much the same. The dealer who cultivates his territory, plants the seeds of knowledge concerning his lines in the minds of prospective buyers, is the one who will reap the harvest of orders.

Let our fancy then turn right now to thoughts of good, sane, systematic canvass of our territory. It will pay well.



# Points on Salesmanship for the Dealer

By C. G. CAMPBELL

Sales Manager, Shinn Mfg. Co., Chicago

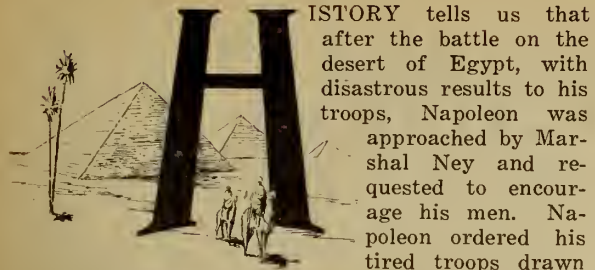

**H**ISTORY tells us that after the battle on the desert of Egypt, with disastrous results to his troops, Napoleon was approached by Marshal Ney and requested to encourage his men. Napoleon ordered his tired troops drawn up in the position

of a hollow square, and, stationed in the centre of this square, mounted on his white charger, he pointed his sword toward the top of "Cheops," the highest pyramid, and said: "Soldiers of France, forty centuries look down upon you."

Salesmanship is an older science than war, for, indeed, as far back as history recites, it has been one of the most potent factors in the development of business, the encouragement of integrity in business, and perhaps it has extended more concrete publicity to the solid foundations on which our commerce is built than has any other influence in the commercial world.

As salesmen—and each manufacturer and retail merchant is a salesman—is it not our purpose as we travel through life, to open the eyes and minds of those we come in contact with, to expect them to accept our statements as truths, that our merchandise, of whatever kind, may have a standard value, and our responsibilities be accepted, and most important of all, to know the relation to and value of personality in selling?

All recognized games of sport must be played according to rules. Business, the greatest game of all, surely must be, if one would succeed. Guess work and "rule of thumb measurement" practice in selling is gone forever to men who would be successful. The new person in business is sometimes handicapped because of lack of knowledge and experience. Many lose because they will not study, and the man "who knows it all," because he will not be guided by the valuable experience of others who are successful.

Let each of us consider our place of business, the trade centre from which radiates our personal ability as dealers. The profit we get on the business we do depends not only on the merchandise we sell but indeed on our ability, our education in the principles of buying and selling and our desire to succeed. Confidence is a factor of success, but "knowledge begets confidence, confidence begets enthusiasm, and enthusiasm will conquer the world," provided there is honesty of purpose supporting it.

**I** TAKE it that knowledge means time and effort in preparation for that business we desire to engage in. We can be successful in life if we can learn the principles for developing our ability and the method of using it in selling the merchandise we buy. When you see a man with a good substantial business, or a man filling a good position, just remember that he did something to get it. Success is predicated on these principles with hard work to support them. A good sale provides a profit for all parties concerned, both to you gentlemen as dealers, and your customers. The idea in selling goods is to lead by suggestion your customer into a buying frame of mind. Get your customer's interest, get his attention, convince him that your article is right, that it is scientifically correct, that it is approved by the highest scientific authorities, that you understand the proper application of it, and that the price is

fair. Many good sales are made on a recommendation of your users. Create a desire in the mind of your prospective customer, and, with the right effort on your part, you will make a sale.

After you have made your sales talk, you want the customer to give you the order. In closing a sale many retail customers must not only be led, but strongly convinced. It is genius to determine which points in the closing sales talk, have the "punch" in them to win over your customer. Each prospect is different, but you are high-class salesmen and you should know how to use your knowledge.

"A man is known by the company he keeps."

"A company is known by the salesmen and dealers who represent it."

Study, work, vim, courage, and a desire for success to give the best that is in you will get results and nothing less. Every man is engaged in some work, first, because man must be occupied to be happy, and secondly, because ambition leads the average man, unless he be a "Bolshevik," to the trading of dollars, whereby a fair margin of profit, over and above his expenses, will be had as a safeguard against the day when his active labors cease.

all very early in life. You all know the early history of China. She had progressed to a point of efficiency in the early days of history—they knew how to make gunpowder, something of the art of printing, and other educational and commercial subjects, but Confucius told his people to stop, that they were so far in advance of the world's knowledge that the world could not catch up, but she has caught up and China to-day is still struggling with the conveniences and customs that have been passed to the discard by the progressive people of the world.

There are four steps in salesmanship that should be observed for success—Attention, Interest, Desire and Decision. The question of getting your prospective customer's attention has many angles to it. It may be that he is a neighbor or friend and that you have his confidence. In this case the approach is more easy. In case your prospect is a stranger, your first meeting, in which your personality plays a large part, opens the way for open-hearted conversation and mutual confidence. This confidence, to which is added a knowledge of subjects that will be mutually interesting, gives you an opportunity of getting his attention.

**T**O arouse interest it is necessary to create a mental picture of the article you are selling. To do this requires a knowledge of the goods you handle. Sales facts must be truthful. Permanent business cannot be built on misrepresentation tend-

ing to dishonest practice. A real salesman is one who first encounters opposition and then removes it. This means that a sale involves a battle of wits. The contest is between the salesman and the buyer and you gentlemen know the type of excuses that the buyer offers. Your prospect's refusal does not mean that you have lost the sale. It is preliminary to the further attack that you will make, because you know his mental attitude and what to do and how to act in order to bring him to your way of thinking later. You may want to drop business for a time, talk things over and perhaps discover some point of common interest that will permit you later to take up the matter of making a sale without resistance on the part of your customer. When I know the hobby or interest of my prospect a big part of the battle has been won. The essential in salesmanship is to develop the enthusiasm that will carry desire to the prospect. Your temperament, good or bad weather, and many other seemingly unimportant things may have an important bearing on your customer's decision.

**D**ESIRE alone will not close a sale. Most people want things which they cannot always possess, so if interest is

sufficiently strengthened it becomes a desire, for the man who is truly interested in a thing wants to possess it.

Just what the salesman is to say or do to help his customer decide is psychological. The salesman has a natural intuition that will guide him in closing his arguments at the right minute. This is the time to stop, close your argument, have your order signed, and be prepared to profit in future sales by the experience of past practice.

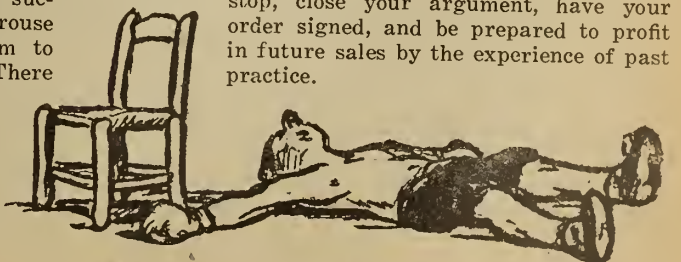

Many dealers take the count through failing to study their goods.



**LEND ME YOUR EAR!**

Get your customer's interest, get his attention, convince him that your article is right.

**I** ONCE heard a prominent business man in Chicago say "that the average man was worth \$5.00 a day from his neck down, but from his neck up he was worth just what he made himself worth." Is it not possible for most of us to apply this statement to ourselves? It is said that 68 per cent. of all men who start in business go through bankruptcy, but if the right man gets hold of a business, he makes a success. This should be sufficient evidence to arouse the fighting spirit in any man and allow him to create the desire of leadership within himself. There is no reason for the average man with a high school education being a failure, and especially if he has a personality, a desire to study, and health to back him up in the pursuit of business.

A great many men cease to study when they start in business, they have learned to know it



This is the second article by L. C. Heimpel, B.S.A., dealing with tractor operations. The first article dealt with the methods of laying out a field for tractor plowing and the present article on "Tractor Plow Adjustments and Hitchers" is the next step in the operations.

As we said in our last issue, these articles were written at the request of the editor for the special benefit of our tractor dealers.

It is of the utmost importance that the dealer should be perfectly intimate with the tractor, both as to its various parts and its every operation. Selling tractors is a highly specialized business and only those dealers who have studied it sufficiently to enable them to instruct the farmer in its various uses and proper care are going to be truly successful.

# TRACTOR PLOW ADJUSTMENTS and HITCHERS

By L. G. HEIMPEL, B.S.A.  
Farm Manager O.A.C.

knowledge of plow adjustments from years of experience between the handles. The engineer who would be a plowman often has not time to gain this experience, and it is really not necessary to spend whole seasons behind a plow to become a good plowman. The laws which govern plow adjustments are few in number and not hard to master if the operator will apply himself to his work with reasonable diligence.

## The Laws Governing the Adjustments of Plows

THERE is an old law in geometry which says that "the shortest distance between two points is a straight line." This law applied to plowing would read: *The centre of draft of a plow and the point*

this imaginary hole in the mould-board, the point of hitch at the end of the plow team and the point of an attachment on the engine in a straight line, our hitch will be correct. These three points must be in line, both vertically and horizontally, giving us two lines of draft, the vertical line of draft and the horizontal line of draft. Both of these lines are provided with a wide range of adjustments to aid in making the hitch a straight line pull.

## Centre of Draft of Tractor and Plows

THE centre of draft or point of balance in a double-tree is half way between the singletrees, in a two-drive wheel tractor it is half way between the

PLOWING is the largest and most important single farm operation on any general farm. More horse-power hours, and man hours as well, are spent in the performance of a season's plowing than on any other farm operation. The ease with which a seed bed can be worked up, the burying of trash and the killing of weeds depend more on how a piece of ground has been plowed than on any other single factor in the tillage of farm land.

The most noticeable feature of the first large tractor plowing demonstrations held in Ontario was the lack of uniformity in the quality of the plowing done by the different companies' demonstrations. While a few of the men who plowed at the tractor demonstration, held at the Toronto Municipal Farms at Langstaff in the fall of 1917, did very good work, the greater part of the plowing was of inferior quality, while altogether too much of it was a disgrace to the occasion. We are glad to note, however, the improvement in the quality of the work in our later demonstrations. Nobody appreciates a good plowing job as well as a good farmer, and if we cannot show it in demonstrations, we have failed in the fundamental principle of the demonstration—to show

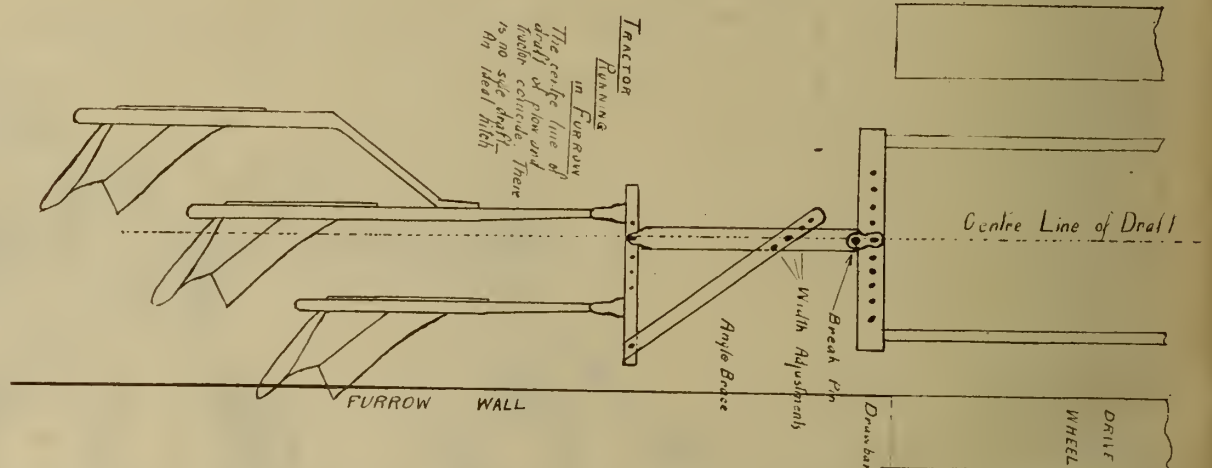

of hitching at the engine drawbar must and will always be connected by a straight line.

Fig. 1 shows what is meant by the centre of draft—also called centre of resistance—of a plow. If one were to bore a hole through a plow mould-board of a single plow about fourteen inches back from the share-point, from two to three inches up from the furrow bottom, and about three inches to the right of the landside or furrow wall, and fasten a wire into the hole and pull straight ahead, that is, holding the wire level and in a line with the plow landside,

drive wheels. The centre of draft or resistance of, say, a three-furrow plow is about five or six inches to the right of the beam of the middle plow and in line with, or parallel to the landside of the plows.

If a stoneboat or a harrow are being drawn from the centre, they will follow squarely behind the team or engine pulling them, because the hitch and the centre of draft are in the same place. If the hitch is fastened to either side of this centre of draft the result will be a new line of draft will be established; the load will again balance itself, but the right front end will swing to the right, and the left rear end will swing to the left. This is exactly what would happen to a plow if it is hitched either to the right or left of centre. There would be a tendency to swing around, so as to balance up the load behind the pull, but the rear furrow wheel of the plow and the front furrow wheel, together with the landsides of the plows, prevent this swinging from taking place. This swinging is not preventable without considerable extra expenditure of power.

Experiments have proved that where landside friction is not prevented, and where the weight of the plow, when in the ground, is borne by the share instead of the wheels, the draft increases by as much as one-third of the amount required to pull the plow. This also is very hard on plow wheels and plow wheel bearings and prevents plows from scouring properly, nor can it turn a perfect furrow. A plow can do good work only when hitched near the centre of draft.

The effect of side draft on the engine is the same, and when the load is drawn from a point much to one side of the centre of the drawbar, there is the same tendency to swing around, and the only thing preventing this swing is the weight of the front wheels on the ground. This means excessive wear on all the wheels and wheel bearings on the engine, and is also responsible for a considerable loss of power.

On a three-furrow plow with twelve-inch bottoms the centre line of draft is situated about eighteen

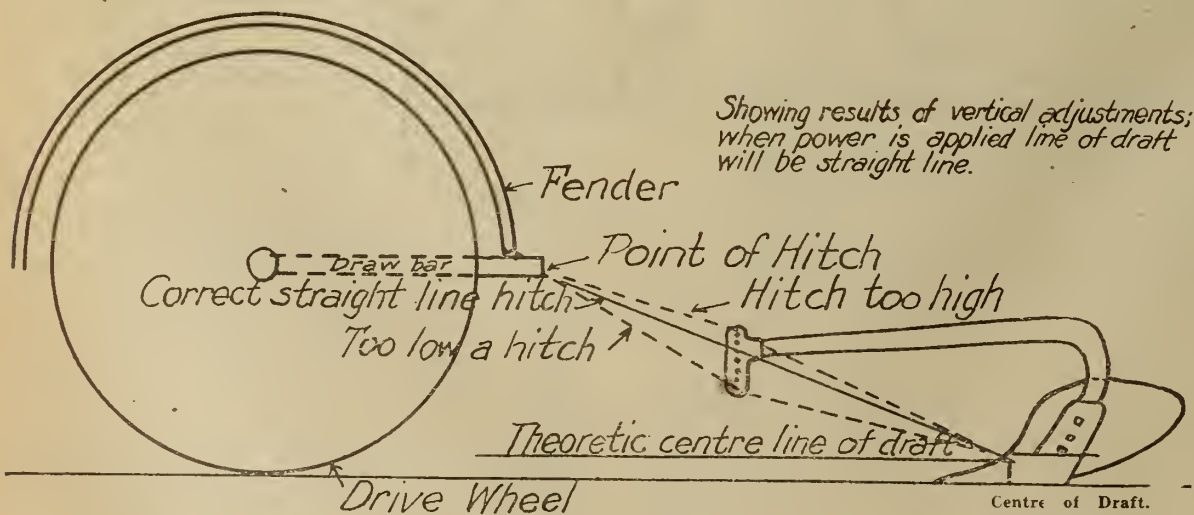

that as good work can be done with the tractor as with horses. To be a good engineman does not mean that an operator is also a good plowman.

The secrets of how to do a good job with a plow are the same in a tractor plow as in a walking plow. A good horse plowman will usually make a good tractor plowman. The average farmer gains his

the plow would run straight ahead without either wheel or guidance from handles. This is so because it is hitched from the point of balance or the centre of resistance.

Of course, to do this the wire would be under the ground, so this is an impossibility. We must draw our plows from the beam, and as long as we keep



inches to the left of the furrow wall. On a tractor sixty inches wide and running on top of the land, where the engine must stay at least four inches from the furrow wall, the line of draft from the engine must be at least thirty-four inches to the left of the furrow wall. This means a difference between the two lines of draft of sixteen inches. The only thing one can do is either to run in the furrow, which brings the lines of draft closer together, or divide the side-draft up between the engine and plow.

A great many tractors have a greater over-all width than sixty inches. While this makes no great difference in the performance of other kinds of cultivation work, such machines are at a disadvantage when asked to pull two or three plows.

#### The Vertical Line of Draft

BY referring to Fig. 1 it will be noticed that the higher the bridle of the plow is above the share point, the more steeply will the line of draft rise to the engine drawbar. When looking over the specifications of tractors I find that the distance from the drawbar to the ground ranges all the way from ten to twenty-eight inches of clearance, while some have adjustable drawbars. One thing is certain, that where the drawbar of the engine is on the same level as the lowest hole in the bridle, or below the lowest hole, we have a condition where it is impossible to make a correct vertical hitch. Of course, where engine designers use a very low drawbar, they also design, or have made for them, a special plow. It

is seldom that one finds a case where it is impossible to make some sort of a shift for a creditable hitch, yet the writer knows of a few instances where a man had bought a combination which could not be made to work together satisfactorily.

A tractor plow is hitched so that the line of draft is bent up; it can result in only one thing—a down pull on the plow. This causes the plow bottoms to run on their noses; the plow will not scour properly and the rear plow will run too shallow. When the plow is hitched too low, which is most likely to be the case when a low-bridled plow is hitched to a high drawbar, the plow will not have sufficient suction or penetration to enter the ground properly, which means that in hard ground it will likely not go in at all. It may even be drawn up so much that the plow wheels have not enough traction to operate the power lift.

By studying the diagrams it should be possible, with the aid of the explanatory material, to form an idea as to what to look for in a tractor and plow combination, as well as to become conversant with the importance of the horizontal and vertical lines of draft of a plow.

#### Starting a New Outfit

WHEN the outfit reaches the field the operator should lose no time in ascertaining the nature and hardness of his job and select the shares to be used accordingly; in heavy or hard ground shares of medium or full suction should be attached, while in

soft, moist soil shares with a minimum amount of suction will do best work. This done, his first job is the adjustment of the hitches; this is done with the plows in the ground and both engine and plow standing in a straight line. After which follows the adjustment of the coulter and jointers.

In moist soils the rolling coulter should be set so that when the coulter is in the ground there is no more than one-half inch of space between the bottom of the blade and the top of the share, and far enough forward on the beam so that a vertical line dropped from the axle of the coulter would fall on a point two or three inches behind the point of the share. The coulter should be set into the land from one-quarter to five-eighths of an inch, so as to cut a little wider than the share and leave a smooth furrow wall.

When the ground is hard the coulter may not be able to cut its way through the hard ground when it becomes necessary to slide it back far enough so that the share will crack the clods from below in front of the coulter, else the coulter will raise the plow out of the ground.

The jointer is of use mainly in burying manure and trash, or in sod, and should be set so that the point enters the ground no deeper than about one and one-half inches.

The tractor plow should always run on an even keel, if expected to do good work. This is best accomplished by close observation of the work done, and by careful handling of the depth levers controlling the plow bottoms.

# Saskatchewan Automobile Repair Act

By G. H. SALLANS

SUPPOSE that I had a car, and you had none, and took a notion you wanted mine, and I sold it to you, and you paid me, and then confronted me with a copy of the Automobile Act, under which I was bound to supply you with spare parts, accessories, all repairs, everything, in fact, except gasoline, for the next five years, I'd feel pretty much as though I had put my foot in it.

Or, suppose that you are an agent, and are under contract for a year. You sell a car one day, and next day the manufacturer, as he has the right on five days' notice, cancels your contract, and you find yourself bound by law to supply repairs for a car you're not even selling, and couldn't if you would. Or, suppose the car you sell goes off the market one season after you sell it, and you still have to carry repairs for it for five years.

Suppose all these things, and you will have an idea what prompted the automobile men of Saskatchewan when they went up in arms against the latest creation of the Saskatchewan Legislature in memory of them, took organized action, together with the Provincial Retail Merchants' Association, against what they called an absolutely unfair act, and secured the promise of the Government that their points would be considered at the next session, and the act further amended so that they will be taken into account.

Even now, it's a long, long way better than when it was first turned out of the Legislative mill, when the clause read that these repairs must be carried for ten years—time enough for the whole automobile industry to change, or go out of existence in fact—and yet away off in Saskatchewan a one-time automobile agent, growing old in the airplane business, or some other line of endeavor, would be worrying away about one little shelf in his plant which contained repairs for a car he sold to Amelius Jones, or Tom Smith, ten years ago, and the aforesaid Jones or Smith, now running his car in California or British Columbia, could hold him by law to supplying him with the necessary repairs any time his paleolithic prodigy broke down. Immediately following the passing of this law, the automobile men got together, and the result of their efforts was that the period was cut down to five years.

The act is exceedingly generous, and provides against any and all comers by the insertion of a clause which says that by "vendor" is meant any person, firm or company or association selling or offering for sale automobiles on his or its own account. The act then goes on to say what the vendors shall or shall not do, and it is with what they shall do that the automobile men themselves take issue. But having been passed, the bill is now in force throughout the long vacation, and next December is the earliest date by which its objectionable features can be elim-

inated. Meanwhile, associations in Saskatchewan are wondering how the measure can be got around.

Seldom has an act been passed, say various auto men, that met, in all its clauses, with such strong opposition, and which was so utterly unsuited and inapplicable to the purpose for which it was created and enacted, as the latest bill known as the Saskatchewan Automobile Repairs Act, passed February 4, 1920. Exception is taken to every clause, and there are nine, the last one stipulating that the preceding shall come into force on the first day of May, 1920.

Putting salt on the wounds, the act goes on, after stating the five years' proposition, to stipulate, provide and other wise declare, that all vendors shall file with the Provincial Secretary on or before the first day of February in each year, a list of the automobiles which they have for sale, with the prices at which they are sold, both for cash and on credit, and showing also in the latter case the usual length and terms of credit and rate of interest charged.

They shall also file a list of all repairs required for the automobiles sold by them, stating the cash selling price and the places in Saskatchewan where they may be purchased. It is generously provided that it shall be unnecessary to include in such list

standard bolts or other iron or wooden parts usually made by blacksmiths or carpenters. In the event of change, supplementary lists shall be filed within thirty days. Failure to comply with this will cause the vendor to be liable to a penalty of \$5.00 for every day during which the default continues.

As no repairs shall be sold for a price higher than that stated in the list so filed, the dealer is bound, in case of sudden advance in prices, to sell at the old price until he can make out a new list and send it in, otherwise he is subject to a fine of \$25. In this case, to protect himself, he will find it necessary to list his articles at a price which will cover any prospects of a raise, and then sell under the list price.

Clause eight of the act, however, is the principal sore point, and decrees that the contract, when a car is sold, shall name a place in Saskatchewan where all necessary repairs can be obtained for a period of five years from date of purchase, for the car sold, and shall provide that the purchaser can secure them at any time within a reasonable period.

Now that the automen have got together, and voiced their objections to the entire act, and the Government has virtually promised to consider their objections favorably at the next session, the clause with respect to listing need not worry them very greatly, as it does not really take effect until next February, by which time it is hoped that the act will have been amended, and the listing will be unnecessary.



Off to a good start. Shortage of farm labor doesn't bother this farmer.



# THE IRON JINX

By B. J. PAULSON

Illustrated by LOUIS KEENE

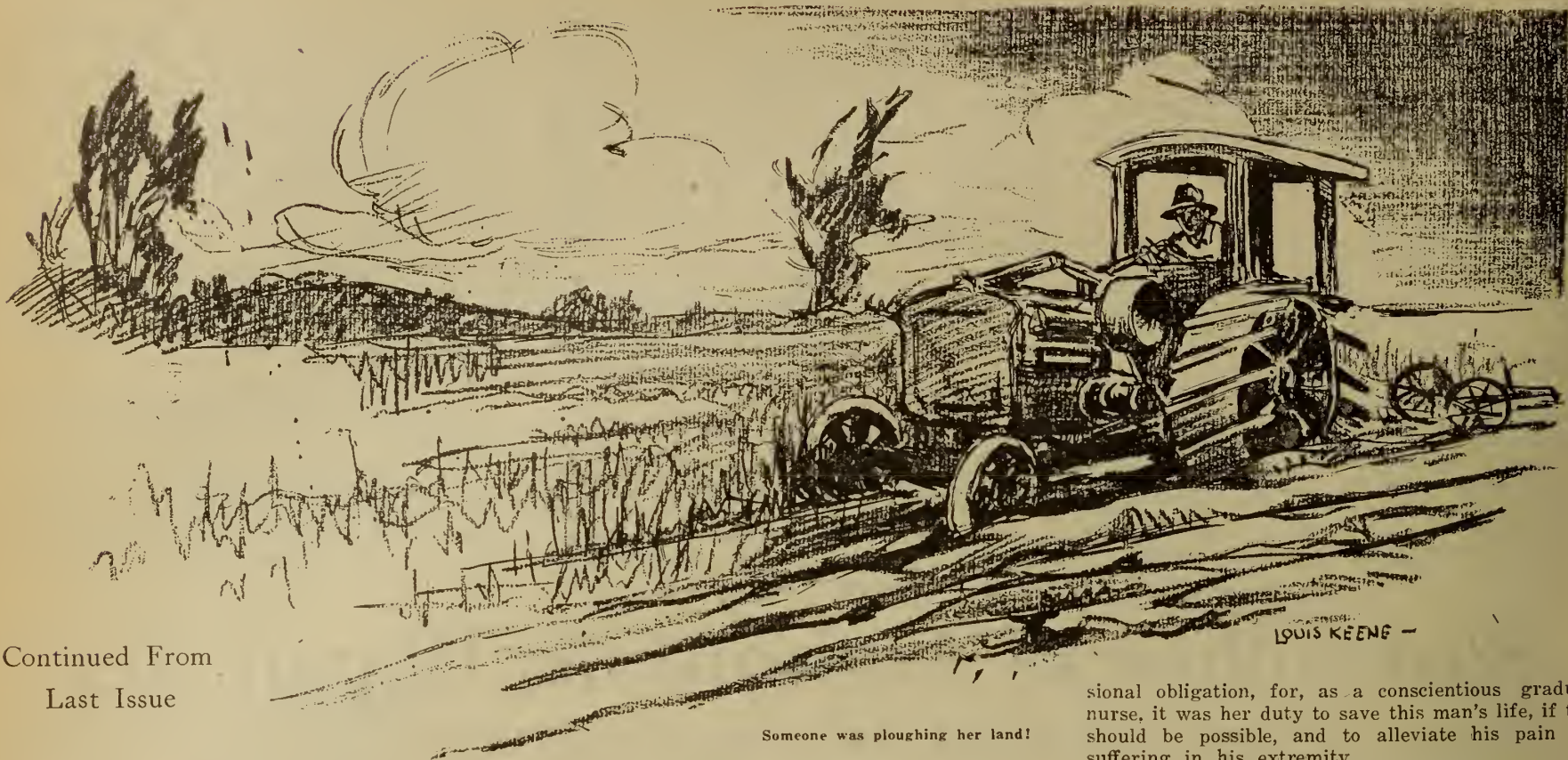

Continued From  
Last Issue

Someone was ploughing her land!

HOW the impossible trip was ever accomplished became hardly more than a blur to Flanders.

He remembered struggling against the wind along the rim of a deep coulee, then plunging through great drifts until the bottom of the chasm was reached; then up the steep opposite wall of the coulee following a drift-obliterated road. When he staggered and would have fallen to rise no more a strong, firm hand supported him, pushed him forward and a clear, crisp voice that pierced like a bell the fog that was clouding his brain urged him on—pleaded, encouraged, coaxed, commanded. The opposite rim of the coulee was achieved at last and then came a long, desperate journey (to Flanders) across the wind-swept prairie. He staggered forward doggedly, obeying to his last ounce of strength the Presence at his side. At last when he was on the verge of utter collapse a small frame cabin appeared before him dancing dizzily in the cold moonlight. The presence at his side—for Miss Springer had quite lost her identity by this time and was to him a wonderful, supernatural presence—helped him to the door, opened it and dragged him inside.

He had a hazy recollection of later events: of being dragged and lifted to a bed; of a crackling wood fire in a sheet-iron heater; of being undressed somehow and tucked under warm covers; of a gratifying hot-water bottle at his quivering spine and a hot brick at his numb feet; of fiery brandy warming his throat and blood and later, desperately swallowing a large capsule. After that Flanders knew no more for some time.

## II

RESPONSIBILITIES had shifted. The weighty responsibility that Ted Flanders had felt that night in the tractor cab when he found himself obligated to deliver a "helpless" girl to her home—that responsibility had become a mere nothing as compared to the self-imposed obligation that that same girl had now assumed. She had rescued Flanders from certain death in the blizzard and was now trying to pull him safely past the crisis of a desperate case of pneumonia that many competent doctors would have given up as hopeless. Alone and unaided she was doing this. Such was the stuff of which Fern Springer was made.

She was thankful for her four years of hospital training. She had been a very capable nurse before her health had broken under the strain of overwork. Her medical training and experience stood her in good stead now. She had handled many cases of pneumonia during her hospital days, so was not at a loss as to what to do for her patient. The chief diffi-

culty lay in providing means for doing it, for her medical equipment and supplies were very limited. It was necessary, therefore, to make up for this lack in personal effort, which she did.

Owing to Flanders' critical condition, it was out of the question to move him, and Fern dared not leave him long enough even to make a trip to one of her neighbors for aid or to dispatch someone to the little town eighteen miles distant for a doctor. So, of necessity, Miss Springer played the double role of nurse and doctor. And, in addition to caring for Flanders, she had her livestock to look after—two horses, a cow and a flock of chickens, not to mention her beautiful collie dog, Chappie, who was her one great comfort during these trying days. There were certain household duties to be performed, too, and the matter of preparing food for herself and patient. Little wonder that Fern lost both weight and sleep; little wonder that the peachbloom began to fade from her cheeks.

Flanders occupied the only bed. As for herself, Miss Springer prepared a shake-down in the kitchen, consisting of a few armfuls of clean hay, covered with horse-blankets, and the scant extra bedding that she possessed. The situation was admittedly unconventional, and when the countryside learned the news, as it undoubtedly would, through some casual visitor caling at the Springer homestead, there would be unpleasant gossip; priggish prudes would invent spiteful tales, and there would be expressive gestures when Miss Springer's name would be mentioned. Fern fully realized this. But what of it? A man's life was at stake.

Of course she could load Flanders into her farm wagon and haul him to town, eighteen miles distant, where there was a small hospital. Or she could have a neighbor do it. And of course, such a trip would undoubtedly prove fatal to Flanders in his desperate condition. But what concern was that of hers? Her obligation would have ceased after her first ministrations, would it not? But would it?

No! Not according to Fern Springer's code. A man's life measured far greater, in her estimation, than the effect of shallow, spiteful gossip. In fact, she would make every possible sacrifice to save him, working tirelessly night and day to accomplish that end. She felt that she was, in a measure, responsible for Flanders' sorry plight because of the fact that she deprived him, through his insistence, of his fur top-coat during the long hours of that bitter night in the blizzard. But quite aside from this aspect of the matter, entirely overshadowing it, was the humane consideration, not to mention the profes-

sional obligation, for, as a conscientious graduate nurse, it was her duty to save this man's life, if that should be possible, and to alleviate his pain and suffering in his extremity.

For several days Flanders hovered between life and death. His temperature climbed and his vitality waned to low ebb. He became wildly delirious at times and, ever-recurrent in his delirium, he would see shady glens where beautiful ferns grew in luxuriant profusion. There were always ferns, for some reason. At other times he would experience wild nightmares, wherein the Jinx was invariably crushing his chest. At such times a cool, soothing hand upon his burning forehead would banish the hideous illusion.

It was a week after the episode of the tractor before the crisis was passed and Flanders had arrived on the safe side. He would recover, barring a possible relapse. When his nurse, doctor and guardian—all combined in one—found that she had brought him through the worst stages of the disease safely, she did a most unethical thing. She cried, thought not in Flanders' presence, of course. Perhaps it was the reaction from the mental and physical strain induced by the high-pressure activities of the past week.

As soon as Flanders' mind was clear of the fog of fever, he insisted that he be moved to town without delay.

"And suffer a relapse, just as you're getting nicely started on the road to recovery?" queried his nurse. "Well, I guess not! If I had known that you were so anxious to die, I might have left you in your old tractor cab to freeze."

"Well, why didn't you? I asked you to."

"Don't be silly. You're talking too much; altogether too much. The next thing you know you'll be running a high temperature again. If you behave yourself and lie perfectly quiet for a few days more we'll have you up and toddling about in just no time at all."

"Miss Springer—why are you doing all this for me?" asked Flanders, as he imprisoned a small, dainty hand that was deftly straightening the coverlet of his bed.

"Because I was entirely out of practice in nursing and you happened to be the first thing that came along that I could experiment upon," parried Miss Springer, smiling sweetly, at the same time gently removing her hand from the weak, wan paw that held it. "I consider myself very fortunate in having picked up a patient so easily. I now feel quite competent and able to spend the rest of the winter as a special nurse, looking after difficult cases at our hospital in town. I am ever so grateful to you for the opportunity you have given me, dear boy."

"I'll get even with you yet," announced Flanders darkly. He had an idea that someone was trying



to tease him. Forthwith he rolled over so that he faced the wall and promptly fell asleep.

Flanders proved an ideal convalescent patient. He never complained nor bemoaned his illness (who would under such conditions!) and accepted the situation with optimistic cheeriness. Between times Miss Springer read short stories to him from a number of good magazines. The fact that some of the magazines were several months old made no difference to Flanders, as the majority of the stories were new to him; and, besides, he would have enjoyed hearing her read them even though he might have previously read the same stories three or four times himself. This was, possibly, due to a certain pleasant quality of Miss Springer's voice; or, perhaps, it was merely due to the fact that the voice belonged to her. At any rate, she would sit in her old-fashioned rocking-chair, very sweet and domestic-looking, and read to Flanders by the hour. The dog, Chappie, would lie stretched out full length on the braided rag rug in front of the little sheet-iron stove, eyeing with adoration his mistress, while Flanders, comfortably disposed in a clean, fresh bed, gazed upon her with not a whit less of adoration in his eyes than in Chappie's.

The time arrived when Flanders was able to be up and about once more. Though loath to leave, he had the courage and force of character to insist on departing without further delay, although still very weak. Miss Springer, at length, consented to discharge him as "almost cured," but wrung from him his solemn promise that he would not return to work for at least two weeks; that he must secure a warm room in a good hotel, and further, that he was to notify her immediately in case he suffered a relapse. Flanders agreed to the latter with alacrity and stated that he would arrange for a prolonged relapse as soon as he was located—provided she would officiate once more as his ministering angel. Whereupon Fern blushed delightfully and advised her recent patient to stop spoofing her.

Fern Springer drove Flanders to town in her farm wagon (she did not own a buggy), and took great care to bundle him up warmly, even providing several hot bricks in gunny sacks to keep his feet warm. She maintained that it would be a reflection upon her ability as a nurse if he suffered a setback. They were a much pre-occupied pair during the trip to town. Flanders, for his part, had a great deal to say, but somehow could not say it. The words seemed to stick in his throat.

The parting proved rather awkward and formal. Flanders, who never did know very much about diplomacy anyway, wished to reimburse his late hostess, nurse, doctor and life-saver for her professional services, board and lodging. He insisted that "the House," meaning the Jumbo Tractor Company, Ltd., paid all his expenses while traveling, and that it was only right that she accept payment as a matter of business. Whereupon Miss Springer became quite indignant and insisted that "the House" had nothing whatever to do with it; that if she accepted payment for what she had done, then he, Ted Flanders, must also permit her to pay for the loan of the fur coat and for the kerosene burned by the Jinx for her warmth and comfort. And so they parted in a petty wrangle.

Flanders, very disconsolate, boarded a train for Regina, where he planned to recuperate for a few weeks. During the entire journey he kept reviling himself as an unutterable ass. He felt that he had made a hopeless mess of things, and, perhaps, offended the most wonderful girl in the world! What could he do to make amends and re-establish himself in Fern Springer's good graces? Ah—the very thing! He'd buy her a Christmas present, for Christmas was now not far distant. But what should he buy her? that was the question. His experience with the fair sex was so limited that Flanders was properly floored by this problem that he had worked up for himself. He had an idea that jewelry would be appropriate, for he had been led to believe that all girls liked gew-gaws. And yet, what would she do with jewels in a lonely shack out on the prairie? Besides, Fern Springer did not appear to be of the jewelry type. A cat, a spick-and-span kitchen and a cozy home would set her off to better advantage.

Flanders was still puzzling over the Christmas gift problem the next day while strolling along one of Regina's principal business thoroughfares. Suddenly his attention was arrested by an attractive display in a store window—a model kitchen furnished with all the latest utensils and appurtenances, one of which was a marvelous kitchen cabinet with the doors ajar, displaying the ingenious interior. Ted instinctively pictured Fern Springer in such a kitchen—it would

set her off to better advantage than a thousand jewels! And now that he stopped to think of it, he recalled that one day while Miss Springer had been reading to him from a magazine, she had paused at a certain page in rapt admiration of an advertisement. He remembered that advertisement. It displayed and expounded the numerous advantages and conveniences of a kitchen cabinet just like the one in the window!

Flanders hastened to one of the leading banks where he carried a savings account, as he made frequent trips to Regina and considered this city more or less as his field headquarters, and withdrew a sum of money which he decided would prove ample for his purpose. Then he hastened back to the store with the hypnotic window display, thrust a handful of bills of various denominations into the hands of a dazed clerk and told that young man to have the entire kitchen outfit in the window boxed up and shipped at once to a certain address from whence there would be eighteen miles drayage inland, and to see to it that the whole thing was attended to and done properly, regardless of cost. This was Ted Flanders' Christmas gift to Fern Springer.

Feeling greatly relieved after executing this clever business transaction, Flanders retired to his hotel and laboriously penned the following letter:

Dear Miss Springer:

I met an old pal of mine to-day—a white-whiskered chap whom I knew when I was a wee bit of a shaver. Mighty nice old gent. He said he was going to make a trip up in the Happy Land Country pretty soon with a spanking team of reindeer and a new sleigh. So I just asked him if he'd mind leaving a little parcel at your place as he went by. He said he wouldn't mind. I know it's a funny kind of a present to send the finest girl that ever lived, but—

Anyway, a merry, merry Christmas to you—  
*Fern!*

Your patient,  
Ted Flanders.

Having concluded this important bit of correspondence, Flanders heaved a sigh, licked a postage stamp, pounded it onto an envelope bearing Fern Springer's address—and mailed the letter.

### III

THE long winter had passed and the earthy smell of spring was in the air. In the Happy Land country of Northern Saskatchewan, the winter wheat, relieved of its heavy blanket of snow, smiled cheerily up at a benevolent sun. Here and there scattered over the fertile prairies of the broad landscape tractors were busily engaged turning new acreages which would be planted to spring grain. In other places horses plodded along, followed by walking or sulky plows, performing a similar service for agriculture and the farmers of Saskatchewan.

But on Fern Springer's homestead the spring farm work had not yet been begun. Somehow, Fern could not stir up any enthusiasm for the task. The year before she had hired her plowing done, but the results had not been altogether satisfactory. For one thing, it had been done poorly, was not disked properly, the seed had been planted late—and she harvested a late, scant crop. Miss Springer was not an experienced farmer, but she knew full well that the neighbor whom she had employed to help her out with the heavy work had shirked and taken advantage of her inexperience. So, during the fall months, she had bravely set out to do her own farm work, regardless of its nature. She had managed to plow ten acres of land with her tough little team and a twelve-inch plow. But it had proved hard work, and she had all but suffered broken ribs from the side-whip of the plow handles every time the plow-share encountered a heavy root or a firmly-logged rock. So she had but small taste for beginning her spring work. If she only had a big tractor like Ted Flanders' Iron Jinx, which, by the way, still remained where it was left on the night of the blizzard—if she only had such a tractor how simple it all would be then, thought Fern.

And then one day, as if in answer to her ardent wishes, a great lumbering tractor, with a magnificent exhaust, appeared from nowhere, drawing a battery of plows—and calmly proceeded to plow a headland along Miss Springer's east line fence—on her side of the fence! Fern was feeding her little flock of chickens at the time she made this remarkable discovery. The dog, Chappie, also made the same discovery at the same time and went bounding out onto the prairie barking vociferously at the invading monster. He would defend his mistress, regardless of odds.

Fern watched the operations of the tractor for several minutes with considerable interest and curiosity, and then amazement. It suddenly dawned upon

her that someone was plowing her land. She had heard of claim jumpers, but for the life of her she couldn't figure out just how such tactics as those she was witnessing could be associated with claim-jumping. The tractor operator must have made a mistake, of course. He evidently had been hired by her next-door neighbor to the east and through a misunderstanding of directions, got started on the wrong side of the line fence. She must hurry and tell him of his error before he plowed further on her land.

Forthwith, Fern hastily deserted her chickens and went tripping out across the tawny prairie, with Chappie leading the advance by many yards and barking a valiant challenge to the iron monster to stop and fight! Fern, for her part, stopped several times to cup her hands and shout: "Yoo hoo, yoo hoo—please wait!"

But the tractor kept serenely on its way, its strident bark quite effectually drowning Chappie's distant barks and Fern's futile effort to make herself heard. So they continued their pursuit of the hulking monster. At length, Chappie, resentful that this creature should so utterly disregard his trespass warnings, left his mistress and went bounding away to the attack by himself. He reached the tractor and circled it, barking lustily. The tractor operator apparently discovered for the first time that he had company. He brought the tractor to a halt, stepped to the ground and spoke to the dog. At the sound of the man's voice, Chappie stopped dead in his tracks, cocked his head to one side and pricked up his ears. He gave a half-hearted "wuff" of interrogation, whereupon the man spoke again. Chappie now bounded forward and all but devoured the man in a wild ecstasy of recognition and welcome, leaping into the air, trying to climb into the man's arms and even succeeded in planting a damp caress on his new-found friend's nose with his long, red tongue.

Meanwhile, Fern Springer was doing her best to cover the remaining distance between herself and the tractor in record time. As she observed Chappie's antics, a light began to dawn upon her. But, no—it couldn't be. And yet—

"Why, Mr. Flanders!" she gasped as she came within recognizing and hailing distance. "You horrid man to make me run so; I just could thrash you!"

And to prove it, she came forward with both hands outstretched, a radiant smile dimpling her altogether adorable face, while Flanders rubbed his greased and dirt-begrimed hands on his overalls and advanced to meet her, his rugged features beaming like a full moon in a clear sky. Their hands met. Followed by a vigorous double hand-shaking.

"Gosh, but it's good to see you!" was Flanders' inelegant but decidedly expressive greeting. "You look better'n 'steen million dollars. You're a treat for sore eyes!"

"And you," retorted Miss Springer, "must be a God-send from heaven; that is, you and your tractor. Only this morning I was hoping that some good fairy would send me a tractor—and perhaps an operator to go with it. And here you are! But please, Mr. Flanders, don't pump my arms off."

"Oh, I beg your pardon," apologized Ted, as he released her hands. "I was so tickled to see you that I quite forgot what I was doing."

"Tell me—where did you come from and how did you get here?" queried Fern.

"Over there," replied Flanders laconically, pointing over his shoulder with his thumb, indicating the general direction of the coulee where the Iron Jinx had hibernated during the winter. "The Jinx has been camping on the prairie alongside the coulee since the night we were marooned in the blizzard. Purchasers cancelled their order on account of the tractor not being delivered when they wanted it. No one else placed an order for the old hoodoo—so we just let her stay where she was—until to-day."

"But what do you think you are doing here on my land?"

"Plowing," grinned Flanders.

"Smarty," retorted Fern. "I have a pair of perfectly good eyes and can see quite obviously that you are plowing—or were, at least, before I interrupted you. But who gave you permission?"

"Don't need any," stated Ted pleasantly. "The Jinx never asks anyone's permission to do what she does. She just goes ahead and does it. I work for the Jinx. And, besides, I have a score to settle with you, if you'll try to remember."

"Oh, but you don't! And yet, I suppose I'm piggy and selfish to say it, but I'm glad if you feel that way about it, if that's your reason for this visit. I do so want to get a few acres planted to spring crops—and,

*Continued on page 26*



# CANADIAN MOTOR, TRACTOR AND IMPLEMENT TRADE JOURNAL

Published on the fifth of each month by

The MacLean Publishing Co., Limited  
TORONTO, MONTREAL, WINNIPEG

JOHN BAYNE MACLEAN,  
President.

H. T. HUNTER,  
Vice-President.

H. V. TYRRELL, General Manager.

LONDON, ENG., THE MACLEAN COMPANY, OF GREAT  
BRITAIN, LTD., 88 FLEET STREET, E.C.

BRANCH OFFICES: Montreal, Southam Building, 123 Bleury  
Street; Winnipeg, 1103 Union Trust Building; Vancouver,  
39 Tenth Ave. West; New York, Room 620, 111 Broadway;  
Chicago, 1401 Lytton Bldg.; Boston, 734 Old South Building.

SUBSCRIPTION PRICE—\$1.00 A YEAR.

OFFICE OF PUBLICATION—143-153 University Ave., Toronto.

Vol. II. TORONTO, MAY 5, 1920 No. 5

## The Great Opportunity

**M**R. DEALER.—You who are selling tractors, automobiles, implements—what are your thoughts regarding the motor truck?

Do you recognize the truck as the great transportation medium of the future? If so, what arrangements are you making about establishing a truck business, and how many are you going to sell?

Thousands of trucks are going to be sold in every county in Canada in the next three or four years. How many of these will be sold by you?

Everywhere the motor truck is being hailed as the one thing that can solve the transportation problem. In Britain and the United States, during recent railway strikes, trucks have demonstrated their efficiency. The trucks did so well during these strikes that—particularly in Britain—they are to be used permanently for hauling goods where a rapid transportation is necessary—such as, for instance, carrying farm produce to market.

The implement dealer has a glorious opportunity to get into this business right on the ground floor. Manufacturers are convinced that the farmer is a great potential prospect for trucks. The implement dealer has been selling the farmer his tractor and giving the necessary service, why should he not sell him the truck?

Special trucks are being built to meet farm requirements, so that there need be no misfits.

Then, Canada is spending money lavishly on good roads. Ontario alone has appropriated fifteen million dollars for this purpose during the next five years. When the various provinces complete their road schemes Canada will have thousands of miles of highway capable of supporting every kind of traffic. In these schemes the rural districts have not been overlooked. On the contrary, the roads have been mapped out with special regard to the requirements of the great agricultural districts.

The farmer needs the truck and is bound to purchase one sooner or later, just as he has had to use the tractor. They are both labor and time-saving machines—two important points to remember in these days of labor shortage.

To succeed in selling trucks, the dealer must be in a position to give service, prompt service, and real expert service. It will pay you, Mr. Dealer, to get busy now and prepare for the great opportunity. You who have been handling tractors and supplying the service FROM YOUR OWN ESTABLISHMENT should have no great difficulty in selling and servicing the motor truck.

The foundation for this business is being laid now by the Good Roads Committee and the advertising campaigns of the manufacturers. Are you going to help build the great structure of "adequate transportation facilities" and get in on the ground floor?

## Sell For Cash

**I**MPLEMENT dealers all over Canada and the United States are becoming convinced more and more of the advantage of selling to the farmer for cash. The old bogey that the dealer can do business with the farmer on a credit basis only has been entirely exploded.

Just why the farmer should come to the implement dealer and expect to be carried over for a year or two or three on a binder, spreader, tractor, or any other sale, is a mystery.

He has to pay cash for practically everything else. Why doesn't he buy his machines for cash?

He has been pampered and coddled and carried around on the dealer's back for years, so that he



has lost the use of his legs. The farmer has legs, and good legs, too, capable of carrying him anywhere. But just as soon as he goes near an implement dealer he is suddenly seized with a paralysis and yells for help.

He has got the habit. It is simply a case of habit, from which he can be educated, as a great number of dealers know.

The implement dealer should get his local banker interested in his business, and where a good prospect has a difficulty in procuring cash at the time of purchase, providing the dealer is sound and the farmer is solvent—there should be little difficulty in coming to a satisfactory arrangement. In numerous districts the dealer and banker are working hand in hand; why not yours?

Of course, there are times, like the present, when the banks shut down tight; but even in a case like

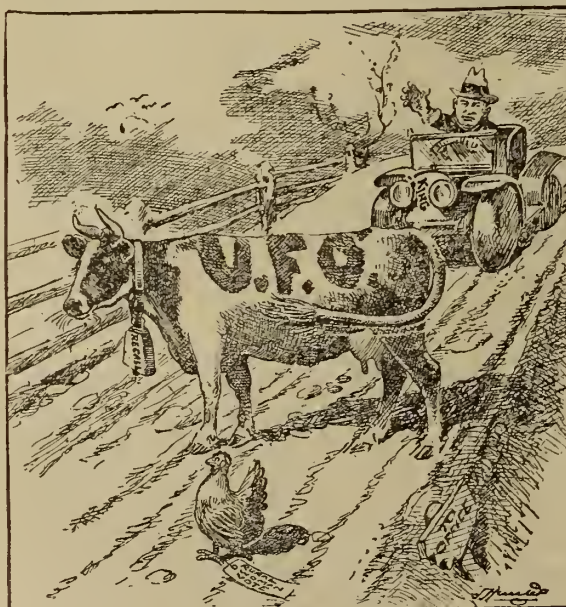

SHOO!  
Sam Hunter in Toronto "World."

the present, a way can be found to get the banker interested.

We know of a dealer who came to the conclusion that in order to make money in selling implements he had to buy for cash and get the discounts. To be able to buy for cash it was necessary in this particular case to sell for cash, too; so the dealer adopted an all-round cash policy. That was in theory—at first. He realized it would be difficult to convince the "credit implement-purchasing farmer" that it was good business to pay cash, and in putting his policy to the test some of his prospects did buy for cash, but a great many insisted on a time sale. He didn't waste much time on argument, but went to his banker and asked him to carry the farmer's note. The banker at first saw nothing in the deal for him, according to his argument, but when the dealer told him that he knew of a man—one of the banker's clients—who was willing and eager to put up the cash and handle the notes, thereby getting about 7 per cent. against his 3 per cent. in the bank, the banker thought better of it and decided to meet the wishes of the dealer.

Each party in the deal benefits by this system. The dealer gets the cash discount, the banker gets 6 or 7 per cent. interest, the farmer saves from 2 to 3 per cent., and, of course, the manufacturer gets the benefit of spot cash.

It is a good system and will work well for you. Try it!

## We Think So, Too!

"THEY are making dealer broadsides too large," said a road salesman, who has an opportunity, eight months in the year, to study the effect of all forms of advertising on the retailer. "In these days of paper conservation, a considerable saving could be secured by cutting down on the size of folders.

"Each year sees an increase in folds and proportion, until now the average broadside is a formidable document to handle. When they are unfolded they more than cover a man's desk or a dealer's counter, with enough to spare to drag the floor.

"It is amusing to see a small-town dealer attempt to unfold one of these broadsides and then fit it together again. The folds are often intricate, yet if this folding does not come out as planned, much of the sense of the advertisement is muddled. This is due to the fact that patent flaps contain parts of illustration, and these, in turn, must match up with some other picture in another part of the folder.

"If an advertising campaign includes double spreads and full pages in newspapers, an attempt is made to reproduce these from the same plates and in exact size. When the dealer unlimbers that circus tent of paper, all you can see of him is the top of his head.

"Such broadsides make an impression, all right, but they are exceedingly difficult to handle. They take up entirely too much space. I contend that any piece of mailing matter sent to a man, which, unfolded, blankets the room and requires the services of a mathematical genius and a Sam Lloyd to put back in its original form, is wrong-headed in construction.

"It really isn't necessary to build broadsides along the sky-is-the-limit lines."—*Printers' Ink Monthly.*

## Don't Get Caught Next Time

**A**RE you experiencing trouble in getting machines to fill the orders you are making this spring? If you are, you are just in the same box as thousands of other retailers.

In spite of the fact that everybody last year was talking about a shortage of material and a possibility of a boost in sales in 1920, a great many dealers neglected to canvass their territory during the fall and winter months for the spring sales, so that their orders would be in the hands of the manufacturer weeks before they would be needed. It is to be feared, too, that some manufacturers either missed their guess or were too easily satisfied with last year's turnover and the volume of business booked for 1920.

Be that as it may, the fact remains that there are more orders than there are goods.

The moral is obvious:

Don't get caught next time.

Make it your business to get your orders in early.



# THIS EARLY BIRD GOT THE WORM

If you were living in a small town, with a population of about 1,500, and at the opening of the season you had sold fifteen automobiles, you might consider that fairly good business.

If you had sold twenty-five cars and five tractors, you would be decidedly pleased.

But if you had netted 35 cars, eight or nine tractors, and had already delivered about twenty rigs in procession, full of implements, you would consider yourself a whirlwind, no doubt.

The foregoing has not been written merely to catch your eye. It is the record of D. Melvin and Son, of Winchester, Ontario, dealers in automobiles, tractors, and implements.

The significant thing about this big spring business of D. Melvin and Son is that the cars are on hand, the implements delivered, and the tractors somewhere on the road between the manufacturer and the dealer.

That speaks volumes for their business acumen. Not only that, but it gives a hint as to one of the main points in their policy, namely:

"Start early and avoid the rush."

THEY started early. In fact, they never stop, and there we have another important point:

"Keep going all the year round."

Mr. Melvin, senior, was a successful farmer until four years ago, when he entered the automobile and implement field.

He operated for years one of the finest farms in Dundas County, only leaving it on account of his health, and with a desire to give his family the advantages of the town.

The automotive business interested him, and as soon as he was comfortably settled in town he started in to sell cars and implements.

"If you want to make a success in this kind of business," said Mr. Melvin, "you must handle a reliable line of goods. When a man knows that his line is right he can approach his prospects with confidence, and sooner or later this confidence impresses the customer, and — well, the sale is practically made.

"We are no price cutters.

"Our price is the same to every man, whether he be relative, friend, or stranger.

"Just the other day we were discussing the sale of a car with a farmer and on quoting him our price he sniffed and asked for a certain discount. To be consistent with our policy, we refused to consider a cut in price, with the result, at present that sale is held up. We know the farmer wants a car badly, and feel sure, as we have experienced with other prospects, that he will come back again and pay our price, which is the regular listed price for that car.

"SUPPOSE we gave one man a special price, and in discussing with his friends—as would be most natural—he boasted of pinning me down to a certain price, what would be the result?

"Every man in my territory would hear about it and would insist on the same price, thus cutting down our working profits and finally forcing us out of the business.

"We go after the business all the time and like to be soliciting orders for goods months ahead of the time when they will be needed.

"We attach great importance to publicity and advertise continually in the local press and by circular letters. We also get publicity from the sales we make.

"Two weeks ago we received a large shipment of implements, and when the farmers came in to get their machines they were surprised and delighted to discover a banquet had been arranged at the Win-

STARTS EARLY—WORKS LONG—GIVES GOOD SERVICE—AND GETS THE BUSINESS.

chester Hotel for their special benefit. They had a great time and sure were pleased, and went away with a good feeling. There were about 24 farmers present.

"The manufacturers of the machinery were represented by their travelling agent; and Winchester was represented by the Reeve and the Press. We had a gay time; short speeches and toasts were the order of the day.

"When the roads clear sufficiently, we hope to have a parade with the 35 cars we have sold this spring.

"These demonstrations we consider worth all the work and expense put into them. They impress the public, please the customers, and create a feeling of good business.

"WE keep men on the road all the time canvassing for cars, tractors and implements. They know the territory like a book, and, judging by this spring's business, have been very successful.

"Service is very important. It is the most important thing, to my mind, in this business. When we sell

basis. An electric elevator connects the three floors of the garage.

A proper system of bookkeeping is practised and each department is put on its own feet.

## Should We Have Tractor Training

By F. H. SWEET

IN almost every issue of farm tractor and automobile journals are write-ups discussing how much free tractor service should be given to the purchaser, and whether the tractor manufacturer or the dealer should render such service. The majority of the writers of these articles feel that the tractor dealer is the one who should give this service. They do not seem to feel that the manufacturer should be called upon to furnish this service through the dealer or direct to the purchaser.

The change from horse to tractor power on the farm came very suddenly and caught dealers as well as farmers unprepared properly to handle this power. In fact, it also caught manufacturers unprepared to

give service for the reason they were unable to employ practical trained tractor operators, hence they had to use men in the field as experts who were not properly fitted for the work.

IN the last few years, many of the leading tractor manufacturers have during the winter months, conducted a two or three days' free service school in order to educate their dealers as well as their customers how to operate their particular tractor properly, most economically and how to overcome trouble which may arise. Lectures are given, some of them being illustrated by lantern slides, but very few practical demonstrations are made, and for this reason those who attend have forgotten the instructions given when they want to use

their tractor in the field four or five months later.

It would be a big saving for the dealer and for the manufacturer if, at the time the sale is made, the dealer would promise the purchaser that if he would attend some school to get the practical training, he, the dealer, would pay part of the tuition. The customer would have success with his tractor and would be a "booster" for the tractor. He would not call upon the dealer or the manufacturer for expert assistance. It would mean the sale of more tractors of that make in his locality, for the neighbors would note his success and naturally would purchase the make of tractor that work so successfully.

MANUFACTURERS should not expect their dealers to give free service or continued service to customers. In the first place, dealers often are not mechanically trained. In the second place, they often have difficulty in obtaining trained mechanics. Good mechanics demand a big salary, hence the dealer cannot afford, on the commissions he receives, to employ such men and to use them to call upon customers giving them free service. The majority of tractor manufacturers allot a certain territory to each agent. In order to get such territory, the dealer must give his order for a certain number of tractors and must advertise and canvass as contract provides for. The contract also provides that it can be cancelled by the company if the dealer fails to comply with these provisions. There is an unrest among dealers, and the sooner the manufacturers assist their dealers in getting the customers trained, the sooner will tractor business be placed on a solid foundation.



This picture shows a line up of some of the 35 cars sold this spring by D. Melvin & Son.

a car, besides supplying an instructor, we give 90 days' free service on certain things, such as ignition, fan belts, etc. We keep in touch with our customers and help them out in every way we can.

"But all our service is not given free. If anything is wrong, and it is the fault of the machine, we fix that at our expense; but where we are convinced of the negligence or carelessness of the owner, we charge the service up to him. We consider that fair, and have found it works smoothly.

"We try to be obliging, but are aware that it is impossible to please everybody, and run a business on correct lines. However, everything goes off very well, and while we hate to be considered independent, we have our own policy and stick to it under all circumstances.

"We buy for cash and sell 60 per cent. of our goods for cash. We will take short notes only from customers of proven solvency.

"Secondhand goods we don't touch, believing it to be bad business. Of course, we will take a secondhand car, but draw the line at implements."

THE Winchester Garage is fully equipped to handle every phase of the garage and implement business.

Storage battery repairing, oxy-acetylene welding and repainting are some of the special features. In the paint shop they can store four cars on a working



# WHO IS THE LOGICAL TRACTOR DEALER?

By ARNOLD P. YERKES

BY what standard are we to judge a tractor dealer?

From the manufacturer's standpoint, the successful tractor dealer is one who can sell a large number of tractors year after year and obtain payment for them. But in order to sell a large number of tractors yearly, and keep it up, two things are absolutely necessary, first, a tractor which will give good service to the owner; and, second, first-class service for the tractor.

These two requirements are the standard on which the dealer's customers judge him, and, after all is said and done, this is the only standard by which the tractor dealer can be judged.

The tractor dealer's success depends upon something more than mere business ability and willingness to do everything within his power to furnish satisfactory service to his customers. If the tractor which he sells is not right—if it will not go out on the farm and stand up under the hard grueling work which tractors are required to do, it is a foregone conclusion that the dealer cannot maintain a satisfactory volume of sales for any great length of time. There have been a great many tractor dealers who have failed largely because they had been unfortunate in the selection of a tractor.

Of course, a dealer is frequently handicapped somewhat in his selection. Oftentimes the agencies for the tractors best suited to his particular territory have been obtained by other dealers in the neighborhood, and he is therefore forced to handle some other make of machine, or keep out of the tractor business entirely. Under these circumstances a great many dealers have selected a machine, which, while they doubtless believed it would prove entirely satisfactory, was wanting in a number of respects, and their future tractor business suffered considerably on that account.

Some dealers have made the mistake of choosing a tractor on the manufacturer's reputation in some other business. There have recently been placed on the market several different makes of tractors, built by companies which had been successful in the automobile business, or some other line, and which thought their experience would enable them to build a successful tractor, regardless of the fact that they were unfamiliar with the work the tractor is called upon to do on the farm and the conditions under which it must work.

In many cases dealers have undertaken to sell the products of such concerns really against their best judgment as to the merits of the machine—simply relying upon the reputation of the manufacturer, believing that the manufacturer's judgment in such a matter should be better than their own. Most of the machines turned out by such concerns have proved unsatisfactory when in actual service, although they had a neat appearance and gave remarkable demonstrations of speed and stunt performance.

The attempts, on the part of the class of manufacturers referred to, to build a farm tractor are quite in keeping with many of the attempts on the part of automobile dealers to handle tractors and farm equipment. Neither has been, as a rule, very successful. Just as the farm implement dealer, because of his intimate knowledge of farm conditions and the requirements of farm machines, has proved in most cases to be the best man to sell farm tractors, so have the concerns with long experience in the farm implement business proved to be most competent to build a farm tractor which would work to the satisfaction of the farmer, and which would last under the treatment which he gives it.

FIRST of all, therefore, it behooves the tractor dealer to use the greatest possible care in selecting the machine which he will sell, as his future business depends very largely upon this. But next in importance is the service which he is prepared to give to his customers on the machine which he sells.

It does not matter how good the tractor may be, it is certain to require more or less service and repairs during its life. It may not need any the first

year, or even the second year, but before it is worn out the owner is going to want repair parts, and quite likely some assistance in making repairs and adjustments, and will look to the dealer to furnish them promptly.

In such a case, if the tractor happens to be one which was built by a "fly-by-night" concern, or a "blue-sky" corporation, which has since gone out of business, the dealer will find himself in a rather undesirable position, as it will probably be difficult, if not impossible, to get repair parts, and a farmer who has bought such a tractor from a dealer is pretty certain to go elsewhere for his next machine. "A burned child fears the fire," and a farmer, who has had such an experience, will not again trust the dealer's judgment, and will probably influence many of his neighbors.

Not only is it more difficult to sell the product of a small, poorly-established company to many farmers, who give such matters thought before purchasing, but it is almost impossible to hold the trade of those to whom it is possible to make one sale.

It is just as important to the dealer, therefore, as to the farmer, to select a tractor which is built and backed by a substantial, reliable concern, which is endeavoring to build its future trade on the foundation of satisfactory service from its products.

As we travel through the country to-day we find there are all grades of tractor dealers. Some are making good from their own standpoint and from that of their customers, while others are dissatisfied with the business and have a great many dissatisfied customers in the neighborhood, who blame the dealer largely for their being in possession of a tractor which they would like to be rid of.

Most all of the dealers who have been fortunate, or, perhaps, it would be better to say, who showed good judgment in choosing a machine to handle, have been able to build up a large and prosperous business, often running far beyond anything they had ever hoped for or expected in the implement business, for the tractor end of the implement business is an exceedingly profitable one when rightly handled and

the proper machine is being sold. The implement business is to-day being carried on by larger business men than formerly—there has been a falling off in the number of small dealers and an increase in the number of those who are doing a large business. This is simply in keeping with the present trend in every line of industry, and is doubtless better for both dealers and farmers. The larger dealer, who sells a great many tractors each year, is in a position to give better service and to give it at less expense per customer than the dealer who sells only a few machines each year.

More large, efficient dealers and fewer small, inefficient ones, will be advantageous in three important ways.

In the first place, the large dealer, who, because of his greater volume, can handle goods on a smaller margin than the small one, can compete on more equal terms with the mail order houses.

Secondly, fewer, but larger, dealers will do away with much of the rather common criticism of the farmer that there are too many small middlemen, who add too greatly to the cost of his supplies.

Thirdly, the large dealer can more easily hold his own against co-operative stores and other similar organizations designed to eliminate the dealer entirely.

HOW many dealers, if they ask themselves the question whether they are making good in the tractor business, could answer in the affirmative? Certainly a great many could not, and these men owe it to themselves and to the industry to find out where the trouble lies and remedy it if possible. Neither the dealer nor the industry is benefited by having the sale of unsatisfactory tractors continued. There are enough makes of tractors on the market which are meeting the farmers' requirements, and making satisfied customers, to make it unnecessary for a dealer to handle the inferior makes.

Furthermore, it is an unquestionable fact that there are enough dealers in the business who are willing and prepared to furnish their customers with the kind of service which will soon give them the lion's share of the trade, to make it more and more difficult for the dealer who is not measuring up to such a standard to remain in business.

The tractor industry has reached a point where the dealer must either make good in an unmistakable manner, or be forced out. There is every indication that there will occur in the tractor industry the same process which has already taken place in the automobile business, namely, the dropping out of a great many of the small manufacturers, leaving the bulk of the machines to be produced by a few large manufacturers, whose products have proved their worth. This being the case, in order for the implement dealer to measure up to the standard which will enable him to lay the foundation for a permanent and profitable business, he should assure himself that he is handling one or more of the machines which will survive.

THE Franklin Tractor Company of Greenville, Ohio, have increased their capital stock from \$300,000.00 to \$2,000,000.00. The company will erect a new building, providing 120,000 ft. floor space on ground level, and will increase their 1920 production schedule of Franklin "Flexibles" and Franklin-Bullocks 100 per cent. The Bullock division of the Franklin Tractor Company, now in Chicago, will be moved to Greenville, Ohio, as quickly as possible.

HYSLOP BROS.' accessory catalogue for 1920 is the largest ever issued by them, having 192 pages crammed full of useful devices for the automobile owner and garage man.

It is profusely illustrated and should be of immense service to the dealer. Pages 141 to 186 are devoted exclusively to Ford equipment.

The catalogue is attractively bound in a blue cover, with appropriate design.

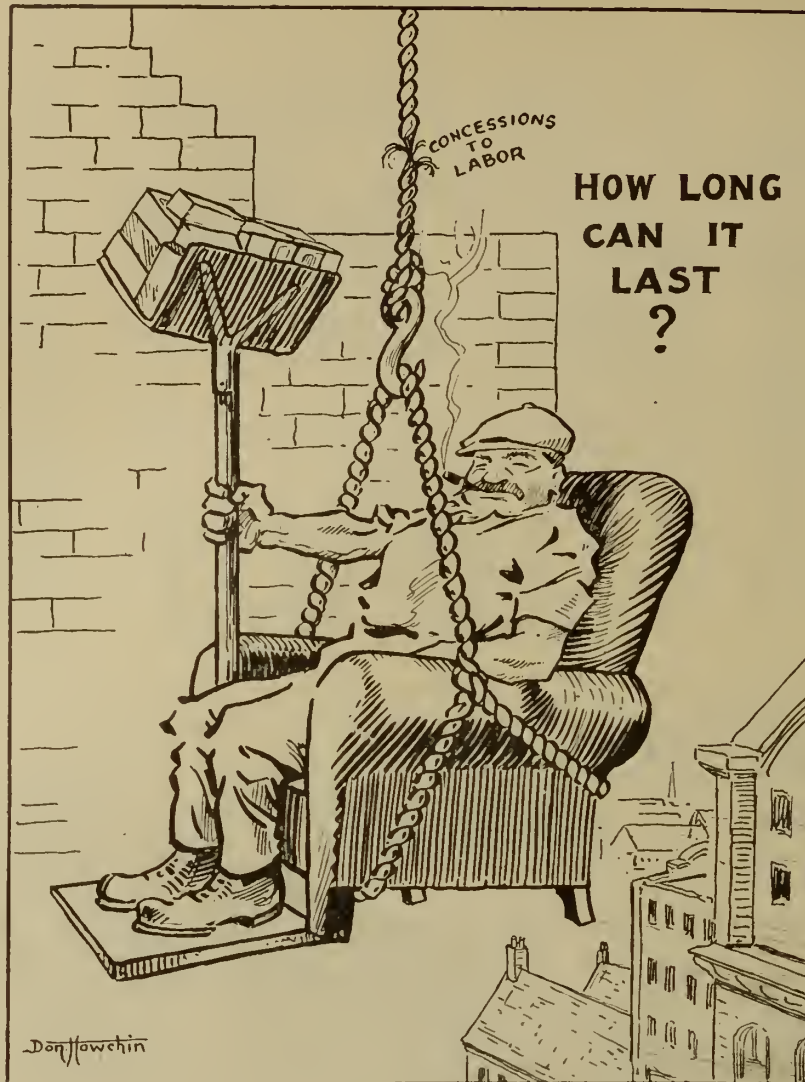

Don Jowchin



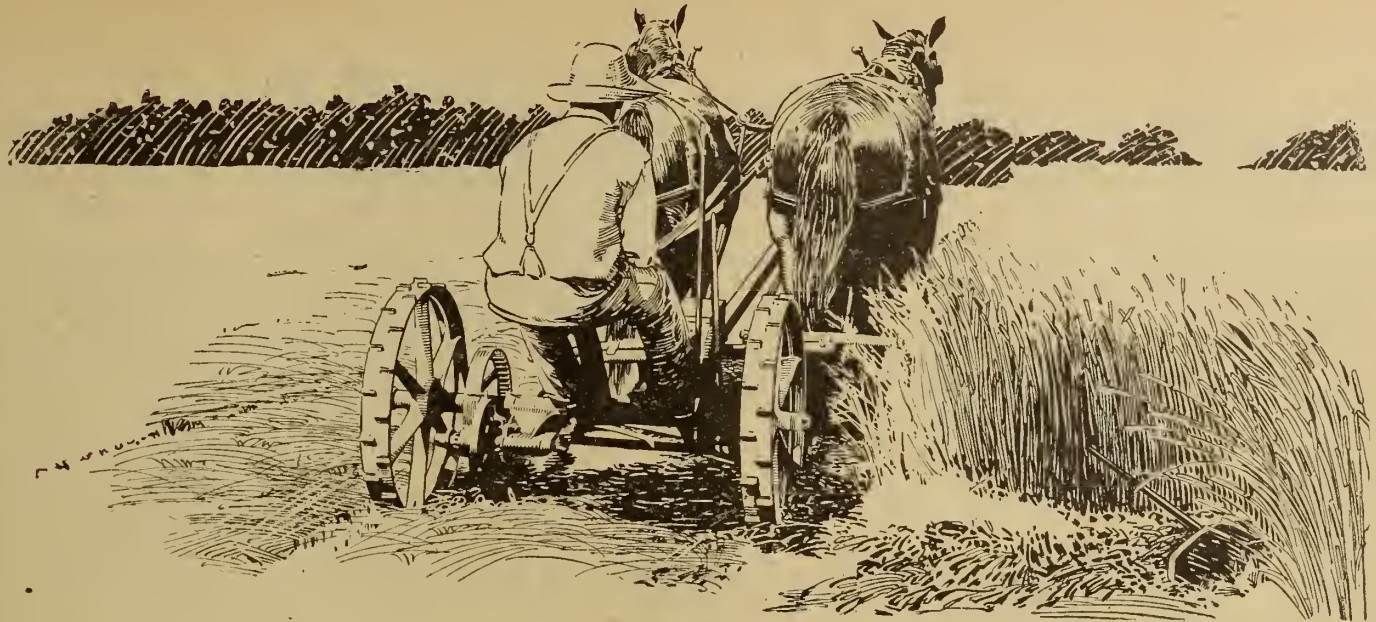

## To the International Agent:

The hay crop is flourishing in the field. See that no grass grows under your own feet. The hay crop points the way for the International agent to build an ever-widening circle of satisfied customers using International Harvester haying machines—a line that for nearly a century has held its reputation for the highest standards of quality.

Make the most of the opportunity given you by the coming haying season. Scatter the best

mowers and rakes over your territory—machines with these old, tried and trusted names: **McCormick and Deering.**

Your customers know very well that these **McCormick and Deering mowers and rakes**, and **International combination side-delivery rakes and tedders, loaders, sweep rakes, stackers, etc.**, will give thorough satisfaction. This knowledge is one of the standard facts in agricultural life.

Teach your prospects why air-curing has sun-drying beat all hollow when they use the International side rake and tedder, followed by the International loader. In these haying machines you have a great ready-made sales force. With a very little stimulating, your sales may be raised to the maximum. Let your branch house help you.

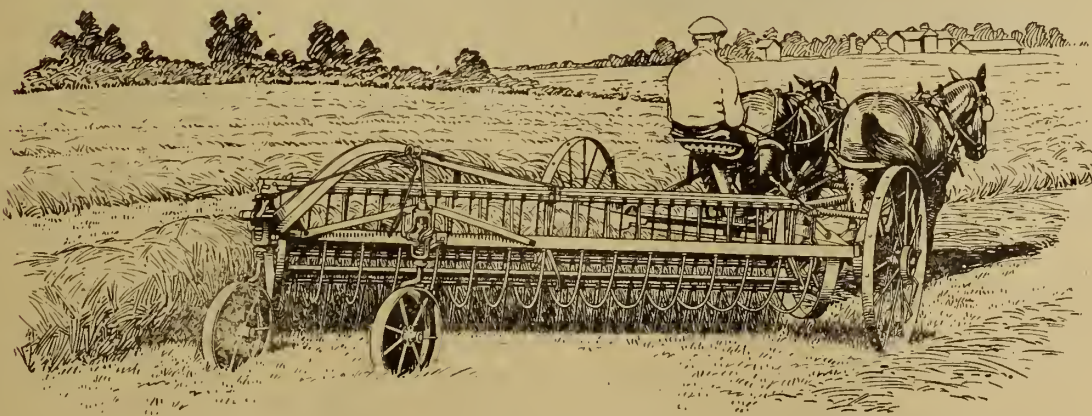

**INTERNATIONAL HARVESTER COMPANY**  
OF CANADA LTD.  
HAMILTON CANADA

WESTERN BRANCHES — BRANDON, WINNIPEG, MAN., CALGARY, EDMONTON, LETHBRIDGE, ALTA.,  
ESTEVAN, N. BATTLEFORD, REGINA, SASKATOON, YORKTON, SASK.

EASTERN BRANCHES — HAMILTON, LONDON, OTTAWA, ONT., MONTREAL, QUEBEC, QUE., ST. JOHN, N. B.

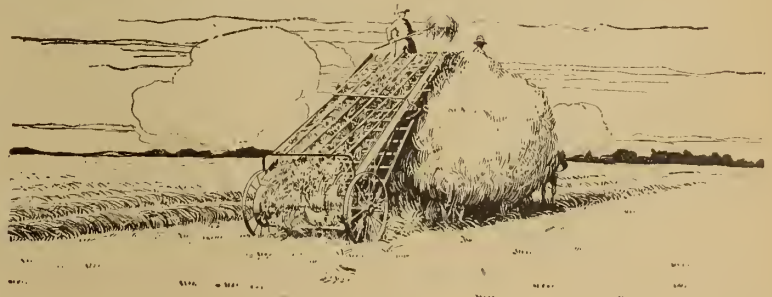



## Sections of Roadway to be Built at Good Roads Convention

At least two sections of roadway will be built by experts during the forthcoming convention of the Canadian Good Roads' Association at Winnipeg, which opens on June 1 and will last until June 3 at the Royal Alexandra Hotel, so that the hundreds of delegates attending will be able to have a practical demonstration of the manner in which highways are built. Offers have been received from the Grain Growers, Ltd., of Winnipeg, and from the Canadian Iron Ingot Co. of Guelph to construct sections of gravel or earth roads during the convention, supplying all the necessary men and machinery, and their offer will almost certainly be accepted. Most of the roads in this part of the Dominion are likely to be of gravel, earth or macadam for the next decade, and the demonstrations that will be given will, therefore, be of much value to the delegates who will attend from all the municipalities who become members of the Association. It is also probable that other roads of concrete, asphalt or macadam will be built during the convention, under the supervision of the most expert highway officials of the continent.

Apart from the practical demonstration, the delegates will also be shown cinematograph films of the processes of constructing waterbound macadam, earth, cement concrete, asphaltic concrete, tar macadam, gravel and other roads, which are being loaned by the Ontario Government, through W. A. McLean, the Deputy Minister of Highways.

The tentative official programme of the convention, which will be presided over by S. L. Squire, the president, and be attended by official representatives of every Government in the Dominion, shows that a wide variety of subjects will be brought before the delegates. The morning of the opening day of the convention will be devoted to registration of delegates, followed by the formal opening of the convention by the Lieutenant-Governor of Manitoba, Sir James A. M. Aikens, and addresses by the Government representatives from the different provinces. The demonstrations of actual road building will commence at noon on the opening day, and at the afternoon session there will be an address on the federal aid to be given by the Dominion Government for the construction of main highways. In this connection the U. S. Government Bureau of Public Roads are sending a special delegate from Washington to speak on State aid for highways. The Dominion Highways Commission are particularly interested in this matter and will have one or more official representatives at the convention.

The important part played by gravel roads in the development of the country will be looked after by an efficient provincial engineer from the East, who will address the convention on this subject. While a provincial Minister from the same district will speak on Surface and Subsoil Drainage, and a well-known Manitoba engineer will speak on highway bridges and culverts. The annual dinner and entertainment of the association will be held in the evening of the opening day of the convention.

On the second day the value of roads as an aid of agriculture will be discussed, followed by a paper emphasizing the importance of foundations in road building. From across the border a prominent State highway engineer will inform the delegates on the best method of improving and maintaining earth, clay and sand roads, while broken stone roads will be the subject of another paper. At noon the annual meeting of the Canadian Automobile Association will be held at which delegates from all the important automobile clubs of the Dominion will be present.

Some valuable suggestions on the financing of a provincial highway system will be put forward at the afternoon session by a representative of the Federal Government, followed by an address on the bituminous treatment of sand roads, and papers on road dragging and various methods of road maintenance. The annual meeting of the Good Roads Association will be held in the evening for the election of officers for the ensuing year.

On the third day of the convention an eminent soldier-scholar from Ontario will speak on schools for highway engineering, while another engineer will give an address on road machinery, followed by a paper on Asphaltic Concrete Pavements, and one on cement concrete roads.

At the afternoon session the opening address will emphasize the importance of a central association in assisting the local good roads associations, which must look after district improvements, and this will be followed by an interesting paper on traffic matters. The remainder of the program will be devoted to papers on road oils and carpet coats, economical methods of transporting road materials, and the use of refined tar in construction and maintenance.

There will be free discussion on all subjects that are brought before the convention, while speakers will be prepared to answer any questions on local problems that may be brought before them.

A very large number of delegates have already signified their intention of being present, and as entertainment is being provided for the lady members of the party, the convention is likely to be one of the most successful held by the association.

## Is This the First Tractor?

THERE is an old saying that a man starts a heap of trouble when he sticks a plow in the ground.

The fellow who started the tractor idea also started a heap of trouble, to judge by the debates we hear on the value of the different types, sorts,

In starting a discussion as to who made the first tractor, we may be "starting something." This illustration shows a home-made tractor, constructed twenty years ago. The outfit consists of a Turner Single Cylinder Engine mounted on a truck made

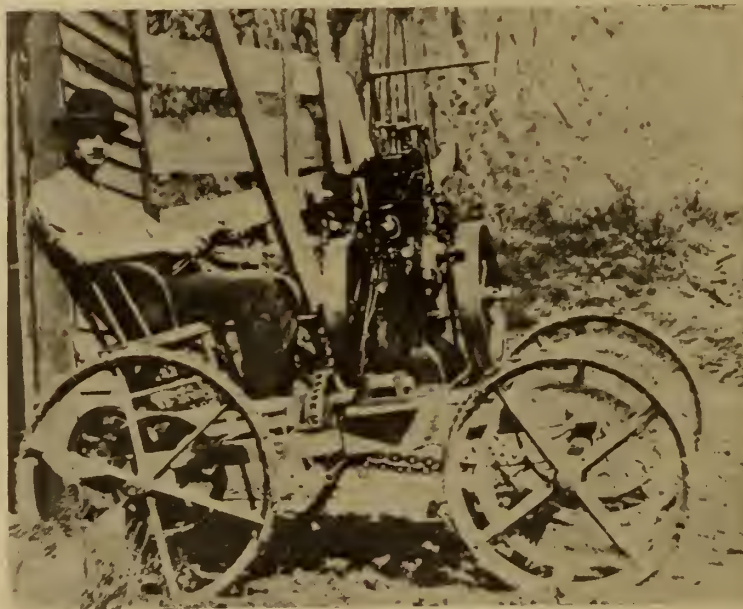

Is this the first tractor?

sizes, and descriptions of tractors. Any way you look at it, you must admit that the fellow who made the first tractor "started something."

Great inventions have always been started by some lazy man, getting tired of hard work and figuring out a machine that would let him sit down and rest while it did the work.

### THE LONGEST NAME

RECENTLY a magazine writer, hoping, no doubt, to start a quarrel over the longest long name, submitted this one belonging to a Blackfoot Indian: Man-Who-Gets-Up-in-the-Middle-of-the-Night-to-Fed-His-Pony-Some-Oats. We know a white man whose name, if it were constructed Indian fashion, would unroll as follows: Dealer-Who-Takes-on-a-Tractor-and-Expects-it-Somehow-to-go-Out-Into-the-Brush-and-Sell-Itself-to-Friend-Farmer-Regardless-of-a-lot-of-Live-Wires-Who-Camp-on-Friend-Farmer's-Front-Porch-and-Gently-but-Firmly-Urge-Upon-Him-The-Virtues-of-Their-Tractors-Which-They-do-Not-Expect-to-go-Out-Into-the-Brush-and-Sell-Themselves-to-Friend-Farmer. This

can be taken either as a breathing exercise or a study in nomenclature.

—Implement and Tractor Journal

### CAN'T STANDARDIZE IMPLEMENTS

THE standardization of farm machinery and parts thereof is hardly feasible at the present time, according to the report given to the agriculture committee of the Commons by the subcommittee which had met the manufacturers of farm machinery in Toronto, says a Canadian Press report. The manufacturers had stated that many of their parts were designed and made in secret, and standardization would give away many of their trade secrets.

John Harold, Brant, a member of the committee which had met the manufacturers, stated that in his opinion the results sought by the committee could not be attained by co-operative means. He thought that perhaps in time the manufacturers would find it to their advantage to manufacture standardized parts together and thus reduce the costs to themselves.

The chairman, R. C. Henders, MacDonald, said the suggestion had been made that the committee meet the manufacturers at Smith's Falls and go over the work there with them. He thought that this plan might be carried out, and the committee decided later on this course.

The committee had a splendid address from Hon. F. S. Tolmie, Minister of Agriculture, who was in attendance. Dr. Tolmie said that he was a farmer himself, first last and always, and his interests were those of the farmers. He had no political ambitions, and "was not in this game" with the hope that he might become a senator. "My ambition," he said, "is to do things right while I am here. I appreciate the manner in which you are letting me talk to you, and I want you to consider me at your service all the time."

The standardization of farm implements, said Dr. Tolmie, was one of the knottiest problems which could be tackled. He thought that there might be a greater measure of standardization.

### HYATT HANDBOOK

THE Tractor Bearings Division of the Hyatt Roller Bearing Company has prepared a series of bulletins dealing with the use of anti-friction bearings from the practical standpoint of the farm machinery designer and are distributing them to the trade.

The bulletins are bound in a loose-leaf hand-book so that subsequent bulletins which will be issued from time to time can be inserted and preserved. The producers believe that this is the first time such a system of disseminating useful information has been inaugurated.

The first instalment of the series includes four independent bulletins as follows: "Bearings for Tractors"; "Bearings for Tillage Implements"; "Bearings for Belt Driven Farm Machines"; and "Tractor Dynamometer Tests."

The subjects are treated from a practical, rather than a theoretical standpoint. Intricate mathematical calculations are carefully avoided. The recommendations are based on the conviction that experience in the field is the only safe guide to correct design. The bearing requirements for different positions on the tractor and other machines are carefully analyzed, and specific applications from current practice are illustrated and discussed.

The bulletin on tractor bearings takes a conventional type of tractor and analyzes its bearing requirements from start to finish, giving a series of tables right in the text listing the bearings suitable for each specific application. Subsequent bulletins will deal with other types of tractors.

The applications of roller bearings to land wheels, furrow wheels, rolling coulters, gauge wheels, disc harrows, soil pulverizers and grain drills are shown.

The bulletins are illustrated profusely by line drawings, and each handbook is numbered and registered under the name of the recipient, in order that he may receive future instalments as issued.

THE Black and Decker Mfg. Co., announce the opening of a new branch office in charge of D. G. Caywood, at 169 Massachusetts Avenue, Boston, Mass. A service station for Black and Decker products will also be maintained at the same address.

EBURNE.—A complete Ford Service Station is being installed by the Richmond Garage.



# FROST & WOOD

# Hay Making Machines

Have a reputation for sureness in work, strength and service that makes them the most popular machine in Canada.  
Why not cash in on this valuable business asset.

## Frost & Wood Mower

With feed stuffs climbing in price your customers know they can't afford to take chances with their hay crops. The high quality bearings of this splendid mower ensure light draft—very important. Its cutter bar strength and superior mechanism guarantee long service, good service, and service just when it is wanted—and that is what counts with a hay crop. The Frost & Wood "Internal Drive" gear is a splendid feature you should know about.

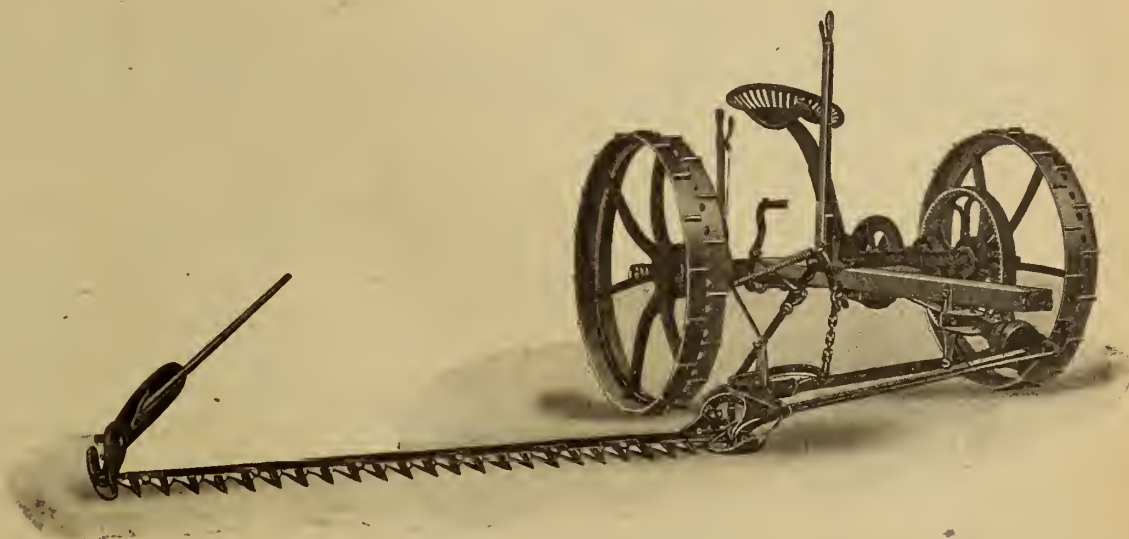

FROST & WOOD MOWER

## Frost & Wood Rakes

The Frost & Wood Automatic Dump Rake is noted for its ever-readiness for service. Frame is high carbon angle steel, strongly braced and with high wheels. A touch of the foot on the pedal and the teeth are automatically lifted and the load is dumped. Teeth are highest quality tempered spring steel.

Our line of Hay Making machinery is complete and every implement in it is tried and proven success. Hay Rakes, Side Delivery Rakes, Hay Loaders, Tedders. Let us send you our special Hay Making machinery pamphlet.

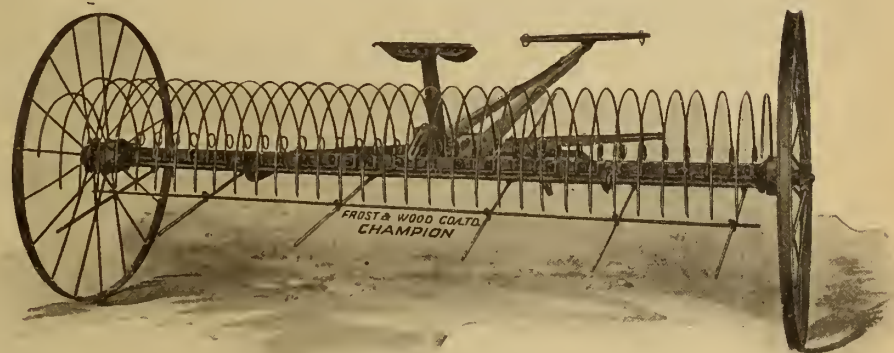

AUTOMATIC DUMP RAKES

The "Tiger" is built in three sizes—8', 9' and 10' widths. The 8' Rake is fitted with shafts and the two larger sizes with combination pole and shafts.

### The Frost & Wood Cockshutt Dealer Proposition Means a Steady, Profitable, Satisfactory Business Growth

Why not find out what it means to your success in business to be a member of the big, prosperous Frost & Wood-Cockshutt dealer family. If you are in the Implement Business to stay, you can't afford to take any chances on not getting the very best dealer proposition there is. Write us to-day.

**The Frost & Wood Co.**

Limited

Montreal Smith's Falls St. John

In Western Ontario and  
Western Canada by

**Cockshutt Plow Co.**

Limited

Brantford - - Ontario

Winnipeg, Regina, Saskatoon, Calgary, Edmonton



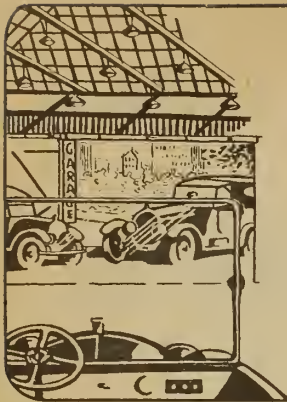

# SHOP NOTES FOR THE GARAGE MAN



## BRIGHTEN UP THE GARAGE

AT this season of the year it is well to look over your garage to see if there is any cleaning or repairing to be done. A good appearance is one of the best assets. A coat of whitewash on your garage walls will brighten it up and will add wonderfully to the distribution of light—a most important point and one not to be overlooked. A good mixture of whitewash is necessary to insure best results. The following recipe will be found satisfactory:

Slake one half bushel of unslaked lime in boiling water, keeping it covered during the process. Strain, and add a peck of salt dissolved in warm water. Add also three pounds of ground rice boiled to a thin paste and one-half pound of Spanish whiting. Dissolve one pound of clear glue in water and add. Mix the whole thoroughly and let stand for several days. When ready to apply, heat thoroughly and apply as hot as possible.

## LIFT FOR TUBE VULCANIZER

A CONVENIENT and quick method of suspending inner tubes being vulcanized above the vulcanizer is illustrated. The lift consists of a metal hook, carried on a cable that extends over two pulleys attached to a wall

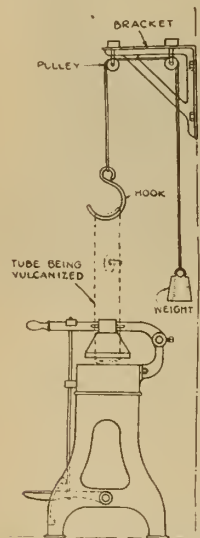

Bearing and Race Attachment.

bracket, and is held up by means of a counterweight. To use, the hook is pulled down and the tube slipped over it; the weight holding the tube up and away from the vulcanizer.—*Firestone Tire & Rubber Co., Akron, Ohio.*

## EXTRACTING BROKEN TAPS

BROKEN taps can be easily removed from material by the following device: Bend a piece of drill rod into a "U," the ends of which are inserted into opposite flutes of the tap, and with the aid of a monkey wrench fitted on the projecting portion of the "U" and with a little careful manipulating the imbedded portion of the tap can be removed. A little oil squirted around the tap, after all bearings have been removed, will facilitate the operation considerably.

## INSIDE REPAIRS WITHOUT SECTIONAL MOULD

INSIDE repairs may be made on pneumatic truck tires with a steam bag where sectional moulds are not available.

The Goodyear Tire and Rubber Company have worked out this plan with marked success:

A sectional air bag of the proper size is placed in the tire over the spot which is to be cured, such as cord patch or a built-up cord patch.

Next, the beads are drawn together

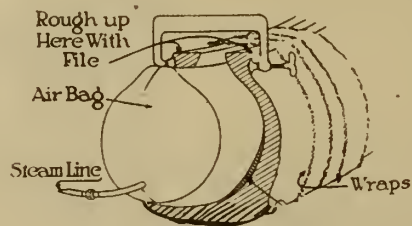

with large screw clamps. These clamps should have the ends that come in contact with the tire roughened with a file, thus preventing slipping.

After the tire has been wrapped firmly at this point, the clamps are removed and steam at 60 lbs. is turned into the bag.

The thickness of the repair being made determines the time required for the cure, and this, of course, must be worked out by the repairman doing the work.

The arrangement is shown in the drawing accompanying this article.

Great care should be taken in wrapping the tire to get enough wraps on to hold the pressure properly, and by all means the clamps should be removed before the steam is put into the bag.

This method has been used successfully and has proven entirely satisfactory where sectional moulds are not available.

## HAND CLEANER

A SATISFACTORY hand cleaning paste for the repairman should have incorporated a satisfactory detergent or cleaner of sufficient strength to attack grease, dyes, or inks, as well as the more soluble dirt, and at the same time should not contain any excess of alkali, as this will injure the skin, says the *Everyday Engineering Magazine*.

The green soap which forms the base for this formula below, together with the ammonia water and oil of turpentine, embody all the features mentioned above. An abrasive or dirt cutter is very essential and finely powdered pumice stone is the best that can be used. Scenting oils are added to impart a pleasing odor to the preparation. The ingredients are:

- Soft soap ..... 90 ounces
- Ammonia water ..... 6 ounces
- Turpentine, sufficient to form a stiff paste.
- Powdered pumice stone ... 30 ounces
- Essential oil (either oil of wintergreen or oil of sassafras) ..... 3 ounces

Mix the soap and ammonia water and add the turpentine. Heat the mixture by using a double kettle to secure

a water bath. Allow the mixture to heat until a jelly-like mass is formed and while still heated, add the pumice stone and stir well while adding, so that it will incorporate thoroughly without forming lumps. After all the pumice stone has been added, continue to stir for five minutes, at the same time dropping in the essential oil that is to be used for perfuming. Set aside to cool for some five to ten minutes and, while still syrupy, pour into containers.

## PREVENT TERMINAL CORROSION

POOR battery connection is the frequent cause of faulty operation of the starting motor. Corrosion of the battery terminals produces this result. Terminals should be kept scrupulously clean, should be greased frequently, and the wire secured firmly.

Vaseline is the best material available for coating battery terminals and connectors. It will minimize corrosion from acid or water that may have been spilled on the sealing compound.

## TO CLEAN SPARK PLUGS

SOMETIMES in cleaning spark plugs by hand the point of the plug is broken. To avoid this possibility it is a good plan to stick the plug in the ground, upside down, fill it with gasoline and touch a match to it. After the gasoline has burned out the plug will be found entirely clean of soot.

## HOW TO LOCATE KNOCKS

ONE of the most difficult problems in automobile engine repairing is, perhaps, locating and distinguishing the various engine knocks. Numerous listening instruments are on the market to help the mechanic, but one as effective as a costly stethoscope can be made by any repairman in a few minutes.

Take a piece of hardwood, 18 in. long by 1/2 in. square, and to one end of it attach an old telephone receiver. If you haven't one lying around you

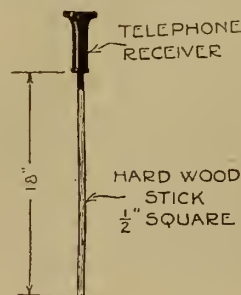

For Detecting Knocks.

can easily procure one at very little cost from your local telephone company.

Even the most intricate knocks can be distinguished by this device simply by placing the stick end of the detector on various parts of the engine. Both rear wheels should be jacked up from the ground when using the detector on the transmission. Throw the shift lever into high speed and pull up the emergency brake, so that they will

drag in the manner produced in driving. Foreign knocks can thus be heard distinctly.

## HANDY ARBOR PRESS

A DEVICE of special importance to the repairman is the Whitney arbor press, manufactured by the R. S. Whitney Manufacturing Co., Lewiston, Me. It combines simplicity and durability and will perform with accuracy all press work to be met with in the repair shop. The makers say both the head and base of the press are substantially webbed, supplying additional strength to those parts subject to the severest strain. The base is provided with ways like those of a lathe, permitting the blocks to slide into various positions, offering a firm

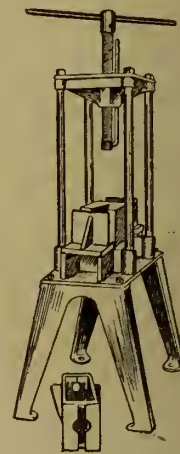

Arbor Press.

foundation for all work. A large recess through the base is provided to allow the passage of shafts, gears, etc.

The screw has a square thread, thus reducing wear to a minimum, the head being supplied with recess, allowing the use of two bars when exceptionally strenuous pressure is necessary.

A special feature is a guide rod sliding parallel with the screw and attached to a cap on the pressure end of the screw, which prevents twisting strains on the surface of the work and by relieving these surface strains there is no tendency to change or weaken the assembly of the equipment necessary to support the work.

Accompanying every press are two sliding L blocks, one sliding V box block, one round V block, and also an axle attachment designed especially for Ford axles.

## KINGSTON-OTTAWA HIGHWAY

THE Ottawa Motor Club has suggested the following route for the Kingston-Ottawa provincial highway which Hon. F. C. Biggs has announced will be built: Richmond road to Bell's Corners, Hazeldean, Stiffsville, Stanley Corners, Ashton, Carleton Place, Franktown, Smith's Falls (branch to Perth), Lombardy, Portland, Elgin, Jones' Falls, Seeley's Bay, Brewer's Mills, Washburn, Kingston Mills, Kingston.



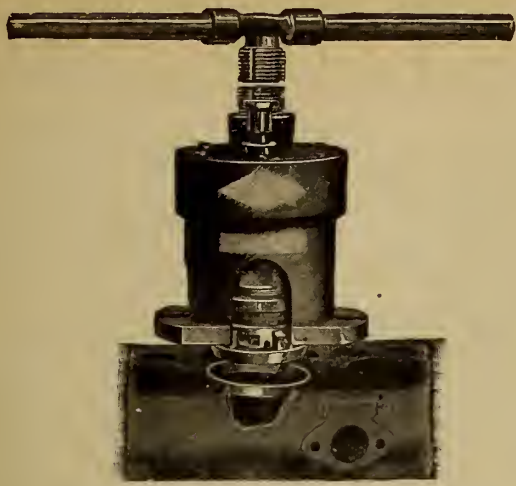

Operating on a detachable head motor—by hand



Operating with power-driven drill press



Tool complete ready for shipment

# Mr. Garage Owner

You can rebore, in your own garage, the cylinder of any automobile, truck, tractor or gas engine and leave the bore as smooth and round as when it left the factory. The

## Universal Cylinder Reboring Tool

is a tool you can't afford to be without — it saves the freight charges, and time spent in sending your customers' engines to and from the factory, thereby enabling you to render a service that will be appreciated, and at the same time bring you a revenue on which there is a real profit.

It is used and recommended by nearly all manufacturers of pleasure cars, and trucks, including Ford, Dodge, Studebaker, Buick, Chalmers, and many others.

It can be operated in conjunction with a power-driven press, or by hand.

In every garage where it is used it has proved to be a most profitable investment, meeting every requirement as to accuracy, workmanship, and general excellence.

*Cut out this Coupon—and mail it to us for further information.*

### Windsor Machine and Tool Works

86-88 Pitt Street, Windsor, Ontario

I, (or we) are interested in the UNIVERSAL CYLINDER REBORING TOOL, and would like to get more information on this equipment. You claim it will materially increase profits of this business; if so, I, (or we) are anxious to know about it.

Send any literature pertaining to same to

Name..... City.....

Street..... Prov.....

We repair the following cars.....

Name of my jobber.....





# The "ESSEX"

## Tractor

**A machine that has made  
a host of friends**

To sell the "Essex" is to build a solid business foundation — a sure-profit business—because the "Essex" never fails to make good. It is profitable to farmers and dealers.

Canadian built, easy to operate, powerful, speedy and economical. It has demonstrated its ability to do more work better and quicker. Write for details of our sales proposition. Get the utmost out of your investment.

## Essex Tractor Co.

LIMITED

ESSEX, ONTARIO

## NEWS — OF THE TRADE FOR THE TRADE

### ONTARIO

**STRATFORD.** — The Board of Works has decided to purchase a Ford truck.

**EXETER.**—J. C. Kestle, implement dealer, is moving his premises to the Baker building.

**NIAGARA FALLS.**—The city council is asking for tenders on a 75 horsepower motor pumper.

**TORONTO.**—The agency for the Commerce truck has been secured by the Jones Motor Co., 188 King Street West.

**TRENTON.**—J. Cummings has purchased a complete "Western" vulcanizing outfit, and will handle all tire repairs.

**GUELPH.**—The store formerly occupied by E. J. Patrick has been purchased by Hanna Bros., implement dealers.

**CHATHAM.** — Isaac Montgomery and Joseph Rankin are constructing a new garage, which will soon be completed.

**DURHAM.**—C. Smith and Sons, dealers in automobiles and farm implements, are remodelling their premises.

**SHELburne.** — G. W. Hepton, Massey-Harris implement dealer, has purchased the garage property of Hand Bros.

**WHITEVALE.**—C. M. Rice has opened a new garage to do all kinds of repair work. He will also handle farm machinery.

**PETERBORO.**—The Oriental Garage is a new garage being opened at 182 Hunter street by J. E. C. Hannah and A. J. Jones.

**KITCHENER.**—Jacob Kaufman, president of the Kaufman Rubber Co., Kitchener, died at his home recently in his 73rd year.

**KITCHENER.** — Operations are under way on the new Waterloo garage, situated on the corner of King and Princess streets.

**PEMBROKE.**—Thos. Pink and Co., proprietors of Pink's Garage, are planning to enlarge their splendid garage to twice its present size.

**GRIMSBY.**—Grimsby and North Grimsby are going fifty-fifty on the purchase of a new motor fire truck for the two municipalities.

**TORONTO.**—The Automobile and Supply, Limited, University Ave., have secured the exclusive selling rights for the Paige motor truck.

**ELMIRA.**—The local branch of the Ontario Motor League met recently for the purpose of reorganizing for the season. New officers were elected.

**BRAMPTON.**—The Reinholt's Chevrolet Sales and Service Station, E. H. Reinholt, proprietor, is the name of a new service garage opened here recently.

**TORONTO.**—G. B. Wheeler, head of the engine department of Canadian Fairbanks-Morse Co., Toronto, visited the Montreal office of that company recently.

**PETERBORO.**—The Duffus Motor Sales has secured the agency for the Beaver truck. This truck is built in Hamilton, Ont., by the Beaver Truck Builders, Limited.

**HAMILTON.**—Hamilton's first automobile show since 1914 was held during the week commencing April 19. It was the largest exhibition of its kind ever held in Canada, except that of the Canadian National Exhibition, Tor-

onto. The show was under the auspices of the Hamilton Automobile dealers and allied industries.

**TWEED.**—LeSage Bros., Gray-Dort dealers, have taken over the garage formerly occupied by J. D. Reeves. They are prepared to handle repairs on all makes of cars.

**BELLEVILLE.**—The Wood Manufacturing Co. will manufacture a newly-invented steering wheel for automobiles and an auto lock. Mr. Appleby, of Sandwich, is the inventor.

**KITCHENER.**—It was announced recently that the fire department is to have a new fire truck. It will be a four-wheel drive, triple combination truck at a cost of approximately \$14,000.

**SOUTHAMPTON.**—H. E. Thompson, of Toronto, has joined his brother, J. A. Thompson, in the automobile and garage business here. The brothers are planning an extension to their present premises.

**TORONTO.**—Magistrate Denison instructed Magistrate Ellis to adopt stricter measures against motorists caught breaking the speed laws and to impose a fine of \$10 on every person convicted of speeding.

**CHATHAM.**—The Gray-Dort Company is extending its premises and has taken over the buildings of William Grays Sons, Campbell, Limited. The company has also erected large warehouses at Montreal and Ottawa.

**SPENCERVILLE.** — L. H. McAuley is enlarging his premises and has installed an up-to-date free air outfit. When the extension is completed the front part of the garage will be used exclusively as a showroom.

**WINCHESTER.**—D. Melvin and Son, proprietors of Melvin's Garage, report exceptionally good business this Spring. Already they have sold thirty Chevrolets and about eight tractors, besides numerous other kinds of farm implements.

**TORONTO.**—The Property Committee has decided to change the civic by-law to permit the storage of 1,000 gallons of gasoline in underground tanks instead of 500 gallons only, as at present, provided that the pumps are located outside buildings.

**RIDGETOWN.**—A local association, affiliated with the Kent Club and the Ontario Motor League, has been organized here. The president is E. H. Betts; secretary, E. F. Savage; directors, J. T. Sales; W. J. Cruickshank, H. F. Hawes, and O. K. Watson.

**COLLINGWOOD.**—Thieves entered the private garage of W. Williams recently and carried off the rear wheels with two new tires, also the rear axle, main driving shaft and differential gear. The car was a Chevrolet and had not been used this spring.

### BRITISH COLUMBIA

**SALMON.** — Messrs. Lester and Thomson plan to increase their showroom and workshop capacity this spring.

**REVELSTOKE.**—Messrs. W. A. P. Connolly and G. W. Bell have opened a new garage and repair shop. They have the Gray-Dort agency.

**ENDERBY.**—James MacMahon and Son have erected a new building 32 x 60 feet. All modern improvements and equipment have been added.

**KAMLOOPS.**—A new concern, the Webb-Barford Machine Company, has started recently to do general automobile and machinery repairing.



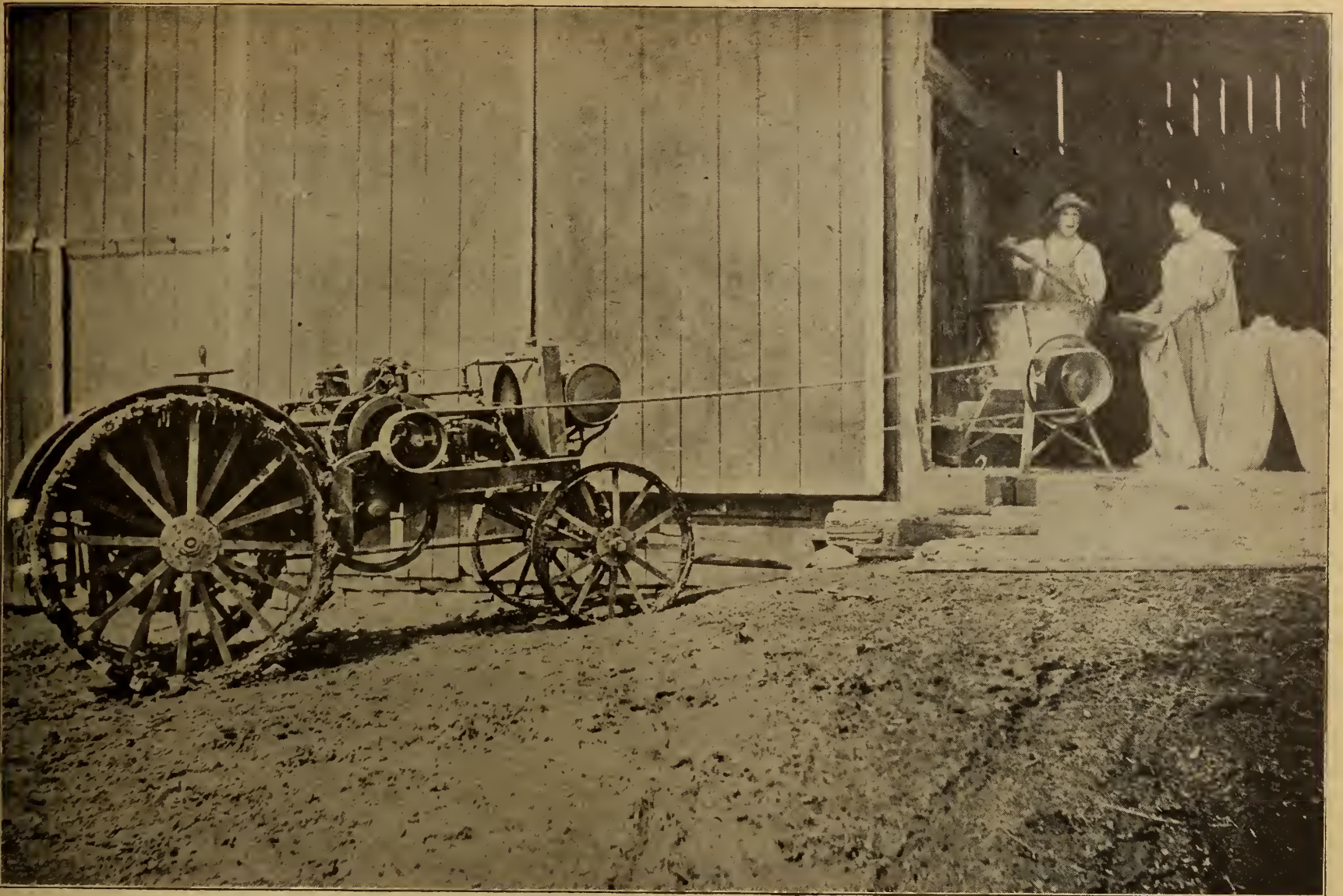

## Feed-Grinding—and Goodyear Belts

THOSE who plan to use their tractors for feed grinding are one of the largest purchasing groups interested in Goodyear Extra Power belts. Their interest in Goodyear Extra Power is due to the same conditions that brought about such a wide use of this belt by threshermen last year. Like the threshermen, they realize that old-style belts slip too much, stretch too much, have to be run too tight, cause too much trouble, and waste too much time.

Modern high-speed machinery needs modern high-speed belts. Goodyear Extra Power Belts are modern high-speed belts—unstitched. They are supple, and hug small pulleys closely. They do not require hours of breaking in, but run sliplessly from the first minute that they are put to service.

Their friction surface grips the pulley face, even when the belt is run loose. P. B. Cleland, near Midnapore, Alta., reports that he has run his Extra Power so slack that any other belt of which he knows would have slipped, and yet there was no slip.

The threshing outfit of Willard Winch, near Unity, Sask., reports that because Extra Power runs without slipping, even when very loose, it means faster work.

Threshing outfits everywhere have found also that Goodyear Extra Power is permanently waterproof, and stays waterproof without any painting or dressing.

Because of this waterproof quality, Goodyear Extra Power does not shrink when exposed to rain, dew or snow. It does not stretch because of heat or dryness.

You can buy Goodyear Extra Power Belts from the Goodyear Mechanical Goods Service Station Dealers. They buy direct from the factory, so that they can sell you this high-speed, supple, friction-surface belt for just a little more than the price charged for ordinary belts. They have both endless and other belts in stock, and can sell you any length in all standard widths. If you want more information about Goodyear Extra Power, either for feed-grinding and other all-round uses—or for threshing and other heavy duty—ask for the Goodyear Farm Book. All Mechanical Goods Service Stations have it, and you can also get copies direct from Toronto.

The Goodyear Tire & Rubber Co. of Canada  
Toronto, Ont. Limited

**GOODYEAR**  
MADE IN CANADA  
**EXTRA POWER BELTING**



# The Renfrew Truck Scale

**D**EALERS everywhere are reaping a harvest of sales. One man sold 800 scales in seven months. We will be glad to give you his name and that of many others who order from us in carload lots and sell them easily.

This Renfrew Truck Scale is so obviously a good thing for the farmer that, often as not, he buys it on sight.

This handy Renfrew Truck Scale enables the farmer to check up on both what he buys and what he sells. It enables him to see that he gets full weight and that he loses no profits.

It weighs anything and everything from 1 pound to 2,000 pounds. Its self-adjusting platform enables it to weigh accurately on uneven ground. It weighs equally as accurately on corners as in centre of platform.

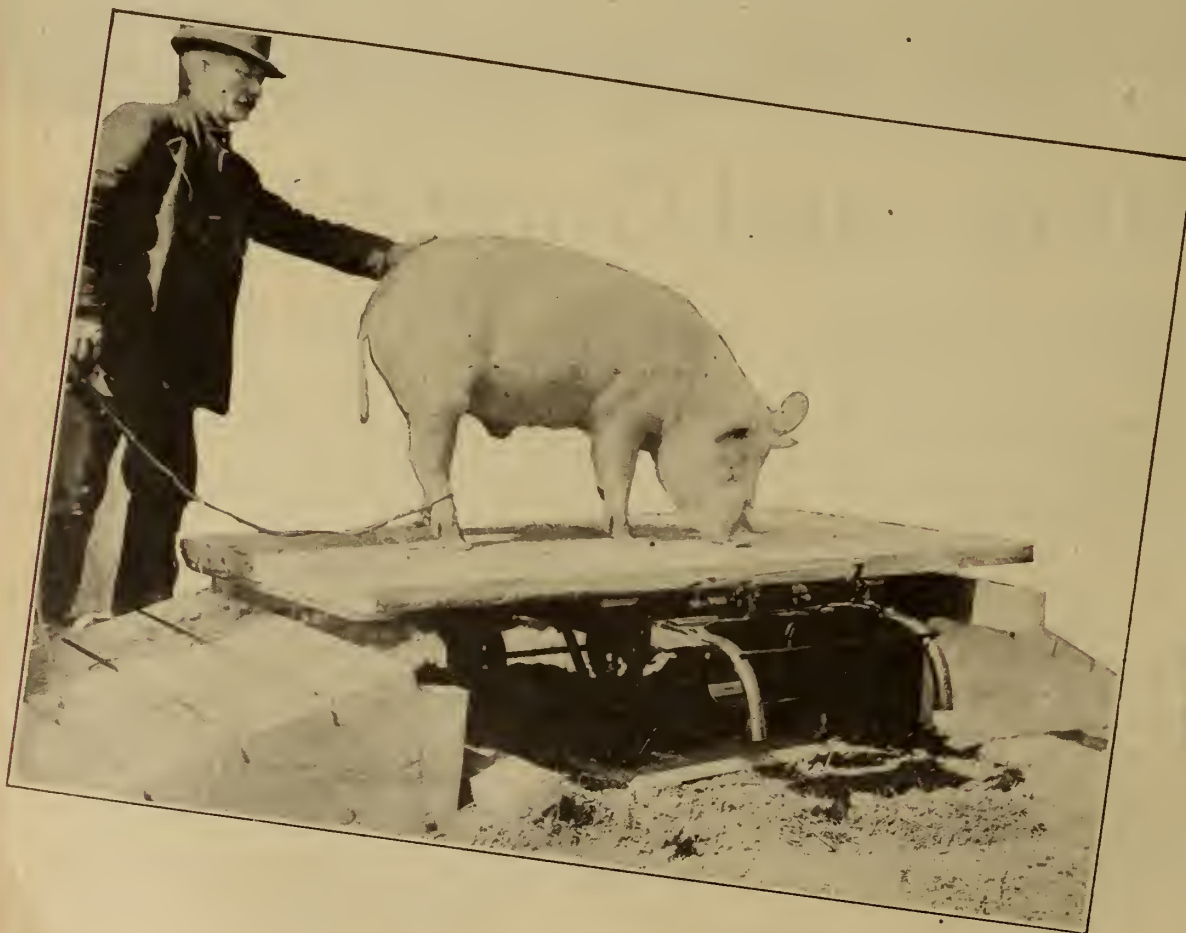

# Ren

**2000-lb**

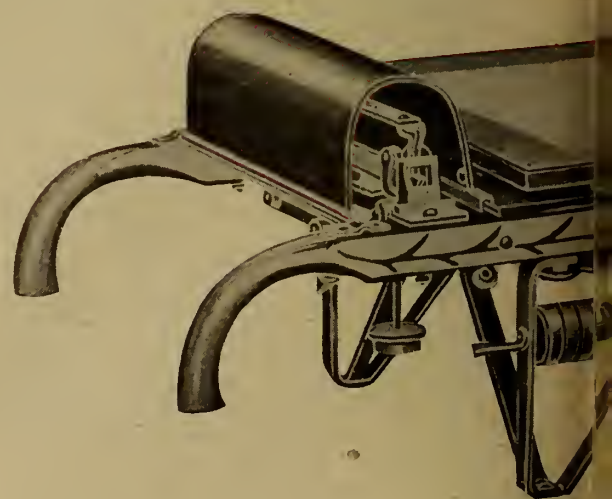

## The Renfrew Machinery Company

*Agencies Almost Everywhere in Canada*

**Other Lines: Renfrew Household Scales --- Renfrew Cream**



# le Sells In Carload Lots

The farmer can place his full confidence in the accuracy of Renfrew weights. Every Renfrew Truck Scale is Government inspected and each scale carries a Government certificate of correct weight.

It is built strongly enough to carry a 2,000-lb. load yet it is not too heavy or cumbersome to wheel about like an ordinary truck.

It is simple in construction and there is nothing to get out of order.

On many farms it pays for itself in less than three months. One farmer writes, "Just this morning I saved \$20 on the sale of a few cattle and sheep."

*Every dealer in Canada should handle this live seller. Our well-equipped factory can keep you well supplied with stock for quick turnovers. We have a handsome proposition for new dealers in open territory. Write for it right away. These agencies are being snapped up quickly everywhere in Canada.*

**Renfrew**  
**Truck Scale**

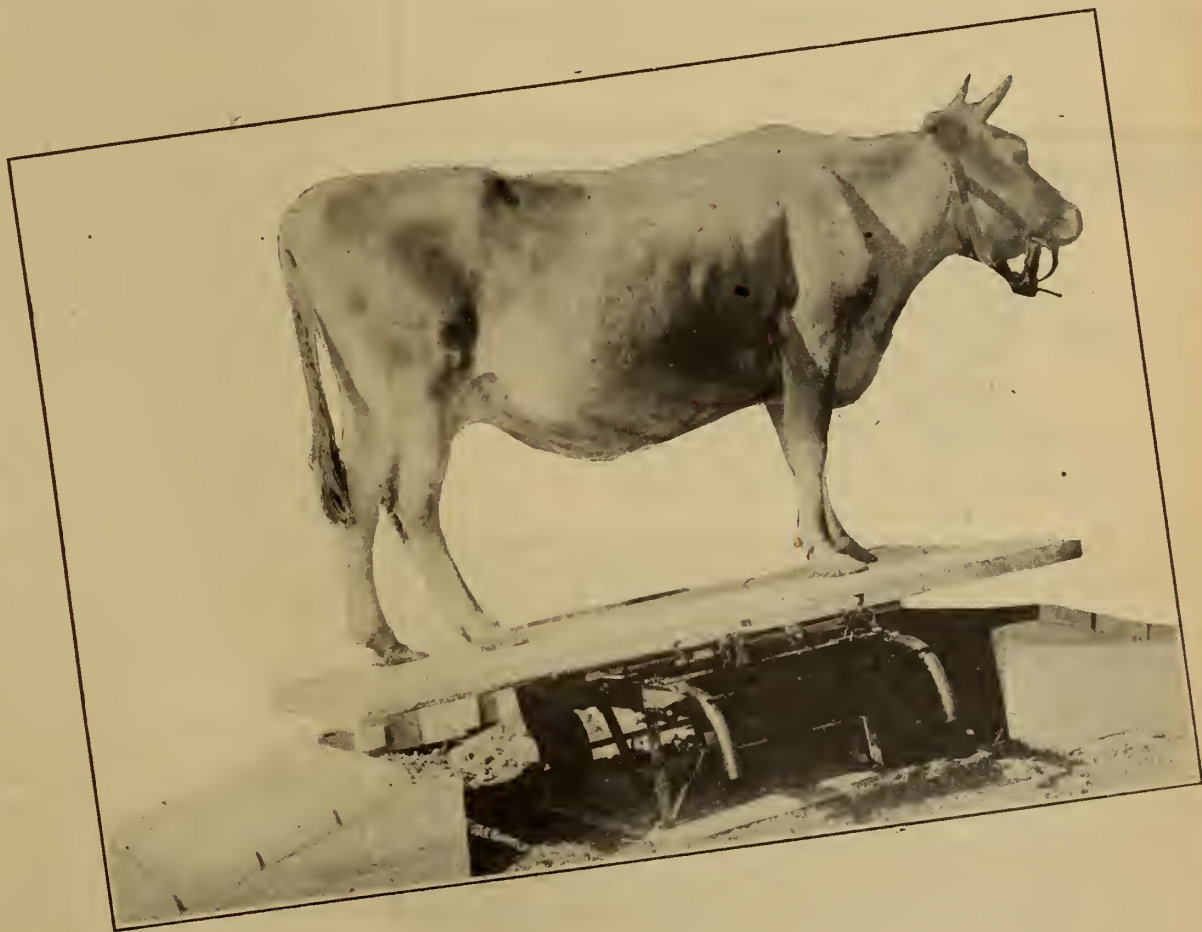

**Limited, HEAD OFFICE AND WORKS: Renfrew, Ontario**

*Branches: Montreal, Que. Sussex, N.B. Milwaukee, U.S.A.*

**Separator --- Renfrew Oil Engine --- Happy Farmer Tractor**



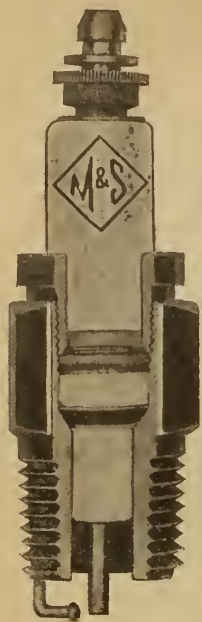

## The Plug with the Hotter Spark

The ball point of the "M&S" spark plug concentrates the current and intensifies the heat. This gives a sure, hot spark—producing better combustion and greater power.

The "M&S" plug is made in all styles to suit every make of car—it is standard equipment on the popular new Overland "4."

The "M&S" plug is made in Canada and guaranteed to give complete satisfaction.

Dealers:—Ask your jobbers for the "M&S" plug.



### SPARK PLUGS

"Made-in-Canada"

No.	Models
500— $\frac{1}{2}$ "	Standard
501— $\frac{3}{8}$ "	Standard
502— $\frac{7}{8}$ "	Long
503— $\frac{7}{8}$ "	Long with Chevrolet Terminal
506— $\frac{1}{2}$ "	Long
504—Regular	Porcelain
505—Chevrolet	Porcelain

### Machine & Stamping Co., Limited

1209 King St. West, Toronto, Ontario

Commercial Dept. Russell Motor Car Co., Ltd.



## BIRDELL CLOVER HULLERS

### 65 YEARS IN THE FIELD

In these days of high costs you must get **RELIABLE GOODS** for money spent or your **WASTE** will consume all of your profit.

There was never a time when "QUALITY" has been in such demand. In Quality and Honestly constructed goods lies the hope of industry today. Buy wisely and you will have economy.

BIRDELL HULLERS have years of experience behind them. They are not an experiment. They are built well and will last a life-time.

They hull and clean Red Clover, Mammoth Clover, Alsike and Sweet Clover seed.

BUILT IN THREE SIZES FOR CANADA

**Birdsell Manufacturing Co.** Foot of George St.  
Toronto, Canada

## THE IRON JINX

Continued from page 13

of course, I'll pay you for whatever plowing you may do, and —"

"Please don't, Miss Springer. I don't blame you for rubbing it in. I know I was an ass that day, but —"

"Truly, Mr. Flanders, I didn't mean it that way. Excuse me, won't you? And that reminds me—I haven't even thanked you yet for that perfectly wonderful Christmas present you sent me. How did you know that I was just wild to have all those nice things? And you didn't even let me know your address so that I could write you a letter and thank you."

"I'm being thanked," said Flanders. "And it's much better this way than by mail. I had it all fixed to come back in the spring, anyway."

"Oh, you did, did you?" queried Fern pertly.

"Sure; had to come back for the Jinx, you know."

"Oh!" There was a note of disappointment in the monosyllabic acknowledgment.

"But mostly I had to come back to see you—Fern." Flanders imprisoned a small hand and clasped it firmly in both his strong paws. There was a quiet sincerity in his voice, and withal, a strong ring that bespoke intense suppressed emotion.

"B-but, Mr. Flanders," stammered the girl, as, with downcast eyes, she began to trace a design in the loose soil with the toe of her boot.

"Please call me Ted, won't you, Fern?"

"All right, Ted." She looked up at him demurely through the drooping lashes that screened her soft gray eyes.

"That's better," smiled Ted. "You may proceed now with your 'but' question."

"Er—really, I've quite forgot what it was. Only—how does it happen that you can spend your time plowing here? What will your employers say?"

"They're quite through with their say as far as I'm concerned. You see, I'm the fifth purchaser of the Jinx. I bought the tractor, quit my job, bought the farm that adjoins your place on the west—and am now an honest-to-goodness farmer. First, I'm going to plow your land and then I'm going to begin on my own. Or what's better, plow both farms at the same time, as I see you haven't built your west line fence yet."

"Oh, that will be grand. It seems like a dream come true," murmured Fern. "Somehow I've felt utterly incapable this spring—and so—lonely! Really, I'm too selfish; I'm so glad you've come. You'll think me terribly bold, won't you?"

"You bold? Impossible! Some day, though, I'm going to tell you just what you are—if I can find the words," grinned Ted boldly. "Let's sit down while we talk things over and renew acquaintances. Pardon me for not having thought to offer you a seat sooner. The platform of this plow-gang makes a good bench. Please be seated, won't you?" Still holding her hand—he had become real possessive during the past few moments—Flanders lead his companion to the tractor and plows, where they seated themselves on the ample platform of the six-bottom plow-gang, Chappie following contentedly and lying down at their feet.

"I wish some of my dreams would come true," continued Ted; "just one of 'em, in fact. But—I'm afraid it's hopeless."

"And what is this particular dream?" whispered Fern, moving just a little closer to Flanders' side. Perhaps the spring air was a trifle chilly.

"I've—dreamed of you as—as my wife," gulped Ted, looking out across the broad prairie with unwavering gaze, although there was nothing whatever on the prairie to command his attention.

"But are you so sure that that is such a—hopeless dream?" murmured Fern, helpfully. "You know dreams—sometimes come true."

"Fern!"

It was possibly an hour later that Fern Springer raised her dainty head from the broad shoulders that had pillowed it, and bethought herself of practical matters, like the sensible girl she was.

"Ted, dearest, we're wasting a dreadful lot of kerosene," she stated (did you note the "we"?). "The tractor engine has been running all this time."

"Let it run," laughed Ted happily. "Let the old girl eat her fool head off. This is my treat. The good old Jinx! If it hadn't been for her, this never would have happened."

And it proceeded to "happen" again.

(The End.)

### DE LAVAL BANQUET

MEMBERS of the De Laval organization to the number of thirty-five met recently in the Empress Hotel, Peterboro, at a banquet held by the De Laval Bowling League. The occasion of the banquet was the presentation of the De Laval Bowling Shield to the winning team.

VICTORIA.—Masters Motor Co., originators of the "self serve" garage, are moving into larger quarters which are now being built on Yates Street. The new premises will give accommodation for 30 cars. Since adopting the self service idea the company have considerably increased their storage business. Each customer is provided with a key and a stall and has free access to the wash racks.

### Sell Holton Hood Clips for Chevrolets



They stop hood rattles. They do away with the troublesome thumb screw. They sell at sight. Every Chevrolet owner is a prospect.

Quickly adjusted without the use of tools. Engine hood can be opened and closed in a second or two. Holton Hood Clips Never Slip. A real spring clip.

Your Jobber Stocks Them

Patented and Manufactured by  
**The Holton Hood Clip Co.**  
WINDSOR, ONTARIO



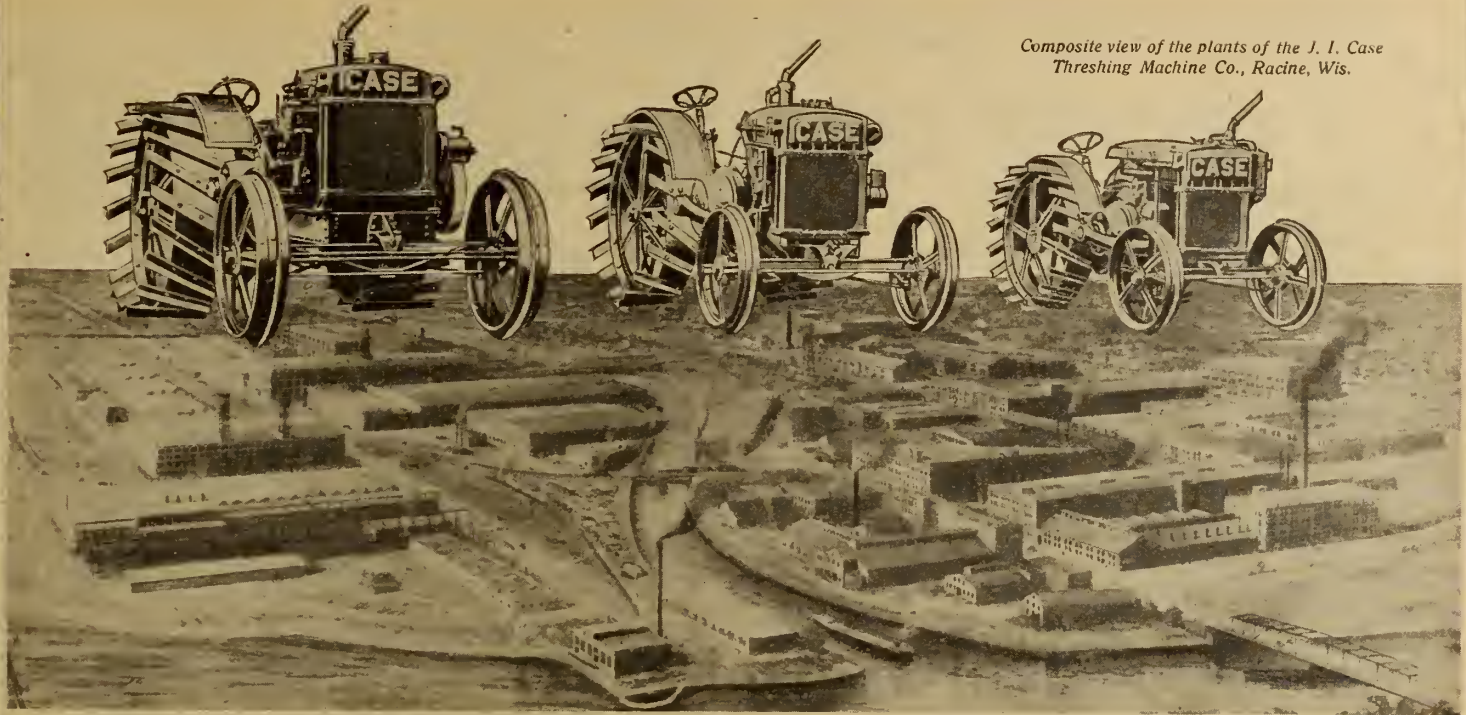

Composite view of the plants of the J. I. Case Threshing Machine Co., Racine, Wis.

# “Thoroughbreds!”

**A**N established reputation for superiority is just as strong an argument to the buyer of a Tractor as to the buyer of a purebred bull.

Show your prospects why the Case Kerosene Tractor is a “thoroughbred;” the factory back of it; and why every machine built in this great factory must be capable of “making good.”

The factories of the J. I. Case Threshing Machine Company were founded in 1842. From the one-man shop in which the first Case Threshing Machine was built, there has grown the great plant shown in the composite view above, now occupying more than

140 acres of ground and employing more than 4,000 experienced workers.

For seventy-eight years this plant has consistently and continuously grown. And during all these years, our reputation for building *highgrade* farm machinery has grown with and beyond the factory until today it reaches every civilized country in the world. For us to build a “scrub” machine would be an act of folly comparable to applying the torch to the factory that produced it.

That’s why every Case machine, bearing the good old trade mark of the Eagle on the Globe *must* be a “Thoroughbred.”



Look for the EAGLE Our Trade Mark

**J. I. CASE THRESHING MACHINE CO., Inc.**

Dept. O-5, 345-9 Dufferin Street, Toronto, Ontario

Making Superior Farm Machinery Since 1842

To avoid confusion, the J. I. CASE THRESHING MACHINE COMPANY desires to have it known that it is not now and never has been interested in, or in any way connected or affiliated with the J. I. Case Plow Works, or the Wallis Tractor Company, or the J. I. Case Plow Works Co.

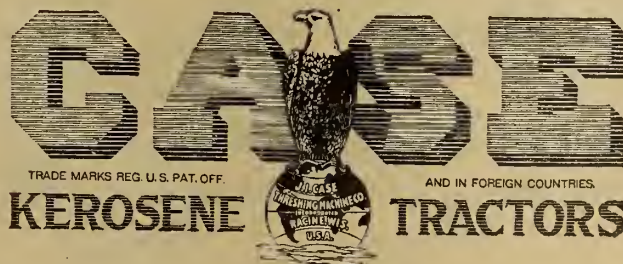

TRADE MARKS REG. U.S. PAT. OFF.

AND IN FOREIGN COUNTRIES



# You can make your shop- Tractor Lubrication Headquarters



**T**RACTORS sold, but not used, cause trouble—cast reflections on the machine's ability.

Farmers who have been advised on lubrication rarely have tractor trouble, and their fuel and repair bills are kept at a minimum.

Correct lubrication of tractors is, therefore, essential to satisfy the customers. Only through sufficient lubrication with the right grade of oil can lowest operating costs be had.

Imperial Polarine Tractor Oils assure that satisfactory lubrication.

In recommending and selling these oils you assure owner satisfaction as well as repeat business.

The Imperial Chart of Recommendations shows which of the grades of Imperial Tractor Lubricants—Imperial Polarine Kerosene Tractor Oil, Imperial Polarine Kerosene Tractor Oil Extra Heavy, or Imperial Polarine Heavy, is recommended for any machine.

Stock these high-grade tractor oils. Sell by the Imperial Chart of Recommendations and **you can make your shop Tractor Lubrication Headquarters.**

BARRELS—HALF-BARRELS  
FOUR-GALLON LITHOGRAPHED SEALED CANS

**IMPERIAL OIL LIMITED**  
Power ~ Heat ~ Light ~ Lubrication  
Branches in all Cities



# One INCH Firing Surface

For Heavy Duty—a practically unbreakable stone insulator, heat-proof, oil-proof;

For instant, complete ignition—*one inch firing surface*—an inch-wide sheet of flame leaping right and left to surpassingly durable wires along whose lengths that flame blazes evenly, distributed, divided—not concentrated to a point that would shrivel beneath its blistering shock;

Plain to the customer's first glance these features instantly reveal themselves in Fyrac—one-piece plug.

Being seen, they sell the plug. Less talking, more selling, for the dealer.

FYRAC MANUFACTURING CO., *Rockford, Ill.*

Canadian Department

Campbell Agencies, 350 McKinnon Bldg., Toronto, Can.

Export Department, Werner & Butts, 336 Whitehall Building  
New York, U. S. A.

Canadian Money at Par

*Durable*

## FYRAC Spark PLUGS



### ONE INCH FIRING SURFACE

This shows the central electrode, from whose *one inch firing surface* sparks leap the gap to the stout right and left wires, made to live long. *One inch firing surface* insures reliable power, and prevents gasoline-formed carbon.



More Profit — Greater Service — Satisfied Customers

## A Viking Contract

gives you all these things that are most desirable to separator dealers



1. You want more profit because it should be worth as much to sell one kind of separator as another — you are in the business for the money that is in it for you, hence if VIKING separators pay you more profit than others, then it is the machine you want to sell.
2. You want greater service because you cannot get too much help in boosting your business — VIKING contracts call for more free advertising and more real sales assistance than any other. VIKING efforts never cease until your stock of separators reaches the hands of your customers.
3. You want satisfied customers, because that class builds up your business, increases your sales, makes your goods talked of favorably, gives you pleasure instead of trouble.

We can satisfy you that a VIKING contract will give you all these advantages. Will you investigate?

Just write Dept. B J

### Swedish Separator Company

MONTREAL—422 Power Bldg.  
WINNIPEG—714 Confederation Life Bldg.

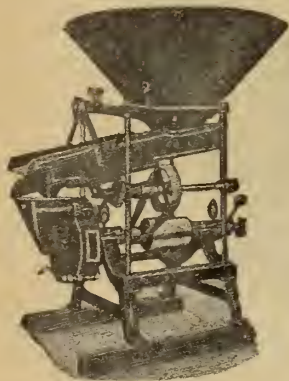

## Increase Your Profits

It is easy to sell "Vessot" Grinders and they stay sold. Customers never complain of the service rendered by

## "VESSOT" FEED GRINDER

POPULAR WITH DEALERS AND USERS  
EVERYWHERE

There are seven different sizes of grinders—6½ in., 8 in., 9 in., 9¾ in., 10½ in., 11 in. B Farm Type, and 11 in., 13 in., and 15 in. Mill Type.

Unequalled for grinding and wearing quality.

Write the nearest branch of the International Harvester Company for Agency proposition. It's decidedly liberal and profitable.

INVENTORS AND MANUFACTURERS

### S. Vessot & Co., Joliette, Quebec

Sold exclusively in Canada by

International Harvester Co. of Canada, Limited.

Branches: Calgary, Edmonton, Lethbridge, North Battleford, Regina, Saskatoon, Estevan, Yorkton, Brandon, Winnipeg, London, Hamilton, Ottawa, Montreal, Quebec, St. John.

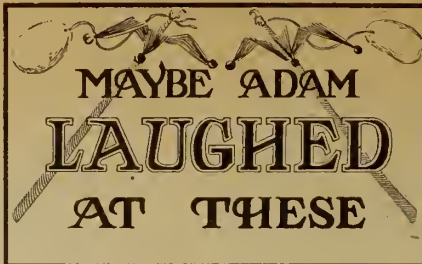

"Hey papa, there's a fly in my soup."  
"Vell, lkey, eat the soup until you come to the fly. Then tell the waiter and he'll give you another plate."

\* \* \*

(Note brought to the Hartford (Conn.) Dispensary.)

Dear doctor.—1. Can't catch breath within 25 minutes. 2. Weak in heart. 3. Knock in heart. Please advise.

\* \* \*

I asked her to lean out and see if the tire was flat. "Not flat enough to hurt," she reported. "It's just flat on one side."

\* \* \*

"Madam," said the conductor, politely, to the colored lady, "you must remove that suitcase from the aisle."

"Fo' de Lawd sake, conducto', dat aint no suitcase, dat's mah foot."

\* \* \*

"Had a puncture, my friend?"

The chauffeur looked up and swallowed his feelings with a huge gulp. He was full of grit.

"No, sir," he replied. "I'm just changing the air in the tires. The other lot's worn out."—Auto Links.

\* \* \*

An English vicar and his curate had quarrelled and the latter was requested to find some other congregation to minister to. The curate therefore preached his farewell sermon and the parishioners came in crowds to hear him. "My text," he said, "is taken from the moving story of Abraham, 'Tarry ye here with the ass, while I \* \* \* go yonder'."

\* \* \*

In one of the leading churches of the city the pastor took for the text of his sermon, "Better Church Attendance."

The pastor held that the automobile has taken more people away from church than any other thing. He concluded with the exclamation:

"The Ford car has taken more people to hell than any other thing that I can mention." Whereupon an old lady in the congregation began to clap her hands and moan "Praise the Lord. Praise the Lord."

"What's the matter, sister?" asked the pastor.

"The Ford never went any place that it couldn't make the round trip, and I am sure that all of those people in hell will be back. So praise the Lord."

\* \* \*

He was not a man of wealth, but of comfortable means, and he resented the exorbitant charges which the hotel manager imposed.

"Why, look here!" he complained, thrusting the bill into the manager's face. "I see you have charged up 50 cents a day for attendance, and I couldn't get any. I'm sure I tugged at the bell rope in my room dozens of times, but got no answer."

"In that case you had better give me the bill and I will have it altered," was the reply.

When, however, the bill was again presented the total was found to be the same, and upon the visitor pointing it out the manager explained:

"Yes, sir, but I have substituted 'physical exercise' in place of the attendance items."

"Physical exercise!" repeated the bewildered visitor.

"Quite right, sir," was the answer. "According to your own statement you have been exercising on the dumbbells for a week."—Pittsburgh Chronicle-Telegraph.

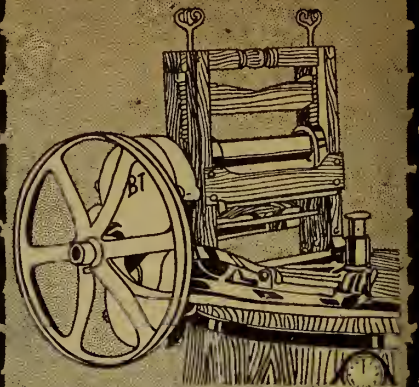

## Saves You Trouble

Your customers need a reliable power washer. You want to sell the kind that stays sold, that works week after week, without any calls reaching you to go out and make repairs.



### Time Saver Engine Drive Washer

The Time Saver Engine Drive is that kind of washer. Every part is strong and substantial

The design is simple. There are no complications to get out of order.

Working parts do not depend on a wooden tub which is bound to warp and shrink in time. They depend on a solid iron bed-plate, like a shaper, planer or lathe. Consequently gears never lose their adjustments.

After years of use the Time Saver runs as well as ever.

We still have territories open for good live dealers. Write to our nearest branch for full particulars.

### Beatty Bros., Limited

Winnipeg, Man. London, Ont.  
Edmonton, Alta. Montreal, Que.  
Fergus, Ont. St. John, N.B.  
16 Holborn Viaduct, London, England

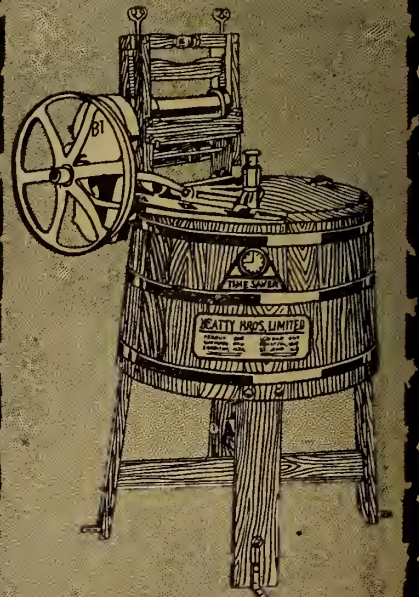



# Over 5 Million used by the Allied Airmen in the Great War

80% of all Airplane Plugs used by England,  
France, Italy and Russia were

## JOLY SPARK PLUGS

On May 28th, Issy-les Moulineaux-Vallacoublay, in France, Lieutenant Jean Casale made the European airplane record for height. He went to 33,000 feet (over 6 miles). Joly Spark Plugs did the job of firing and came down all to the good.

### Why These Records?

Because they yielded them 70 to 80 hours service (nearly the average life of an airplane motor) on the powerful high compression engines where speed knew no variation—where hours of constant resistance to this punishment left them ready for more and then more.

The life of the ordinary airplane spark plug is less than half the above number of hours.

This business, with its production, was completely absorbed for war purposes during four years. We have acquired the American and Canadian rights and are now building the JOLY SPARK PLUG for cars, trucks, tractors and airplanes.

The Joly Spark Plug for automobiles, tractors, etc., is opposing the same comparative, tremendous resistance to time and hard knocks as did its "brother of the air."



**Leaders  
of their Kinds  
in the World**

### Automobile Type

The Joly Spark Plug cannot develop carbon, leak compression, short-circuit, cause pre-ignition or fail to synchronize between explosions.

1. This plug is compact, sturdy and simple in construction. The first impression it gives, even on sight, is that of endurance. Clear from its central electrode to the cap, strength, endurance and right provisions against trouble are in plain sight. In years of service it has never developed a single failure.
2. Joly design embodies features that assure even expansion and positive immunity against compression leak. The insulation prohibits short circuit.
3. The integral heavy milled fingers at the base of the jacket prevent pre-ignition by reason of the ample radiating surface. A comparison of this design with the formal slender alloy poles will prove this. These, with the oversized central electrode, cause an even spread, circular mass spark—not a blaze.
4. Breakage is impossible. The heavy insulation is protected by a specially designed milled electrode aperture wall, which also allows for no oil leakage.

### Mr. Dealer:

A plug such as this, with performance record never equalled, is worth your consideration.

The basic points of design briefly noted have made the Joly Spark Plug a creation of endurance and faultless service such as has never before been offered to the motoring public.

Our acquisition of this impressive business, with its wonderful facilities for production now operative here, marks a new era in American Spark Plug development.

May we have a trial order. List price for Automobile Type \$2 — for Airplane Type \$4.

**Lyons Ignition Co., 215-219 Fourth Ave., New York**

Export Dept., Aggressive Agencies Co.

35 Notre Dame St. East, Montreal, P.Q.

1 Madison Ave., New York City



Airplane Type

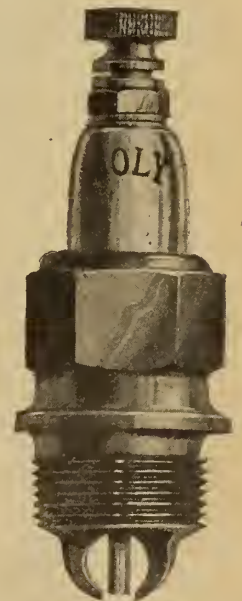



# Automotive Accessories and Implement Equipment

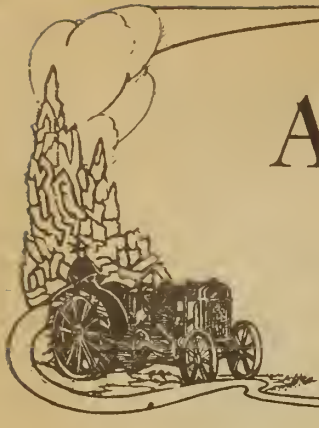

## USACO AIR COMPRESSOR

BECAUSE of the fact that it is necessary in a number of cases to have a compressor that can readily be removed from one place to another. The United States Air Compressor Co., of Cleveland, Ohio, U.S.A., have recently put out their Giant De Luxe Two Stage Compressor in portable form.

It is an ideal unit, the makers say, for all classes of work where air is needed to inflate tires or to blow dust out of motors, generators and other machinery. It has a capacity of 7 cubic feet per minute which is so fast that the air cannot be pulled down below a working pressure.

It is equipped with a patented automatic air release and unloading device. This device, when the motor stops, releases the air in the auxiliary starting tank, permitting the motor to start again against the pressure and gradually pick up the load. This eliminates the chances of burning out the motor through overloading and reduces the wear and tear the motor usually experiences when starting against a load. The Two Stage feature greatly increases efficiency, reduces vibration to a minimum, and prolongs the life of the outfit.



Usaco Air Compressor.

## TIMER EXTENSION BRACKET

THE Sta-Kleen timer extension bracket, manufactured by the Milwaukee Air Power Pump Co., Milwaukee, Wis., is constructed so that the timer and wires are elevated to a position where they are away from the fan belt, and the dirt and grease.

Aside from keeping the wires and timer free from oil and water, the makers say, this arrangement places the timer where it is accessible for inspection at any time.

To instal, simply remove the timer and place it on top of the extension. The bevel gear of the extension fits the bevel gear where the timer was located.



Timer Extension Bracket.

## GASOLINE GAUGE

STANDEX Incorporated, 341 East Ohio Street, Chicago, Ill., are offering to the trade their new imperial-gallon gasoline gauge, which they state records accurately the entire quantity of gasoline in the tank of Ford or Chevrolet automobiles, and will measure both round and square tanks.

The device consists of a solid head, with regulation thread on the short nipple which screws into the tank on the car, in place of the original cap. The dial being on the top, is constructed in such a way that it permits an opening parallel to it, which is almost as large as the original in the tank, thus permitting the tank to be filled without waste and yet not disturbing the gauge. The opening in the gauge is threaded and has a cap which screws into it.

The gauge is made in two styles: Model A for round tanks, such as those used in touring cars, roadsters or trucks, while the Model B is adapted for Ford closed cars or where a square tank is used.



Gasoline Gauge.

## DRILL CHUCK

THE Jacobs improved drill chuck, manufactured by the Jacobs Mfg. Co., Hartford, Conn., supplies the demand, the makers say, for a chuck with combined accuracy and strength. A special distinguishing feature is the toothed sleeve and key.

By means of this key, a drill, tap or other tool can be easily and securely tightened; but as the action of the key differs from that of the ordinary spanner, in that it is not inclined to revolve the spindle, this chuck is convenient and effective requiring only one hand to operate. The illustration is Model No. 1—A chuck in actual size.

The chuck may be easily taken apart by forcing the sleeve off over the smaller or jaw end of the chuck, when the nut, which is made in halves, may be taken out, leaving the jaws free to be removed. When the jaws are receded, they extend into the recess in the sleeve. Therefore, it is necessary that the jaws be partially extended before forcing off the sleeve.



Jacobs Drill Chuck.

## RUNNING AND FLOOR BOARD MATS

THE Fernald Mfg. Co., North East Pa., are placing on the market a new running board mat and floor board mat. The running board mats are made in two sizes and the floor board mats are made the same way in a third size. The manufacturers claim the floor board mat is a real comfort to the driver as it keeps the feet from slipping on the floor board, relieves tension on the leg muscles as well as giving the driver a firmer footing.

The running board mat, the makers say, is a perfect scraper that lets its owner travel in all weathers and all sorts of roads without covering the inside with mud any time one gets in or out. It also protects the running board from wear. Some of the features pointed out are, that they are easily fastened to the running or floor boards, one screw at either end attaches, and once the screws are in they do not have to be removed. When the mat is cleaned, simply loosen the screws, twist the mat slightly, and lift it off. These mats are not flexible as they carry straight strips of steel to make them rigid when in use, it is stated.

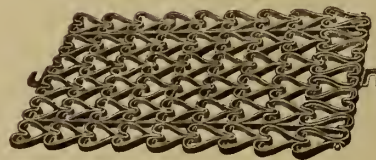

Foot and Running Board Mat.

## CANFIELD TRACTOR GOVERNOR

THE Northwest Manufacturing Co., North Fifth Street, Minneapolis, Minn., has put on the market a tractor governor designed for the Fordson Tractor. The makers say it guarantees a uniform speed under all conditions of operation. Ball bearings are used at all points of wear and roller bearings at all points of contact. It is self oiling from the timer cup and is dust and water proof. It is very easy to instal. No holes required to be bored in the crank case. All that is necessary is to remove the bolts and use the holes in the outer edge of the crank case. The governor is strongly made and all working parts are enclosed.

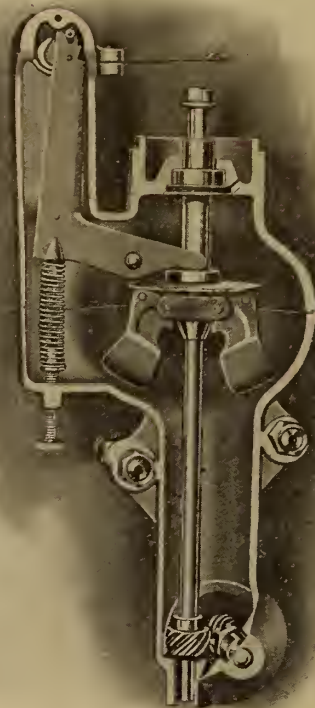

Sectional View of Canfield Governor.



Spring Plowing is only one of the many tasks of the

# Allis-Chalmers

GENERAL PURPOSE TRACTOR

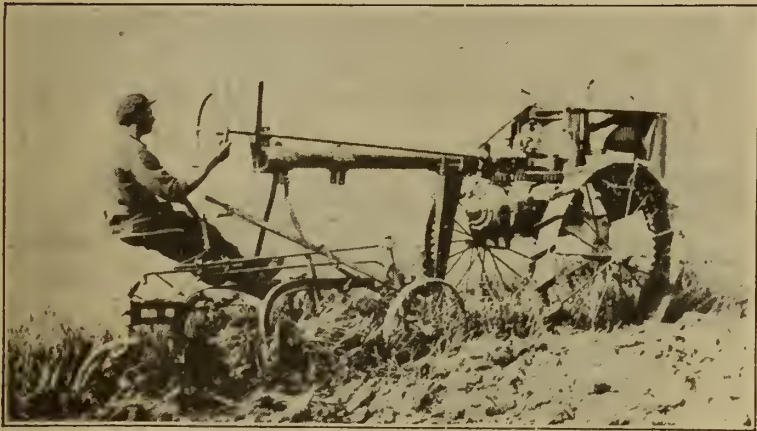

It will plow disc, seed, plant and cultivate.

It will pull a binder, mower, rake potato digger, manure spreader, etc., all as a one-man outfit.

No special implements required. Easily attached to any make of farm implement requiring 4 horses or less. 12 belt horsepower.

And for the heavier jobs we have the 18-30. Proven a leader in the tractor field. Most modern construction throughout.

Will pull 4 plows and pull them fast.

Well over 30 horsepower for threshing, etc.

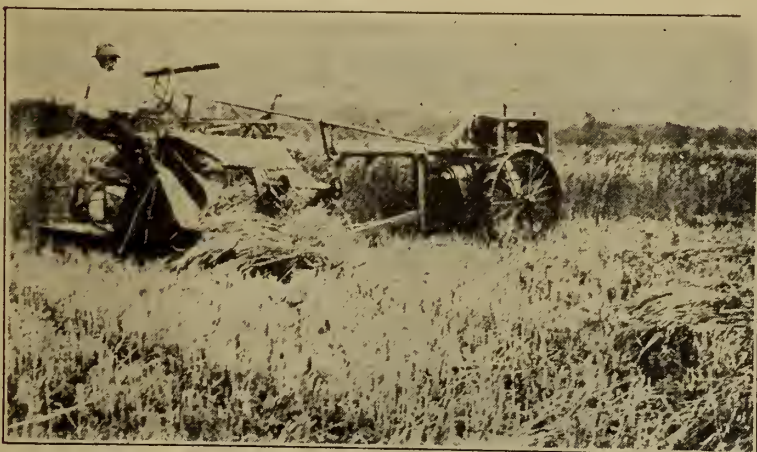
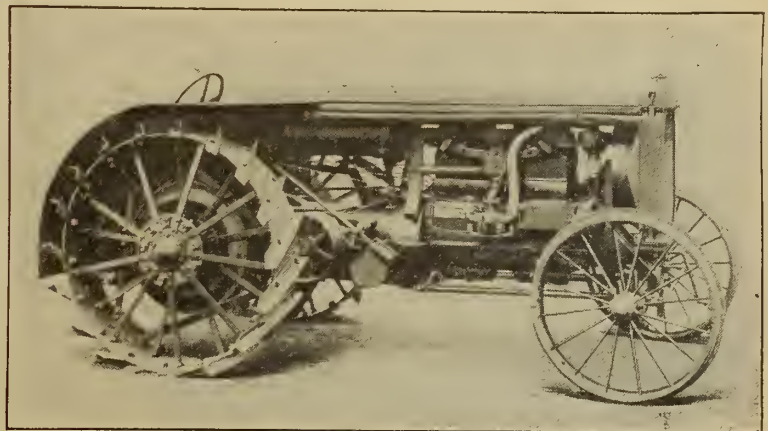

**Dealers! Distributors!**

Why not sell a real year-around line of tractors, backed by one of the largest Companies in Canada.

Write for our money-making propositions.

**DO IT NOW!**

**Canadian Allis-Chalmers, Limited**  
Head Office - 212 King West, Toronto



## THE BEST BUMPERS OBTAINABLE



"KABEE"  
SPRING ARM CHANNEL  
BUMPER

"LYON"  
RESILIENT BAR  
BUMPER

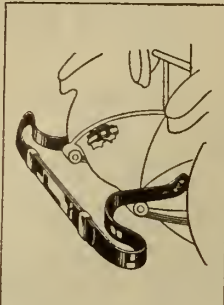

DURABLE BRILLIANT FINISH  
PATENTED "HOOKBOLT" ATTACHMENT  
FITS 90% OF STANDARD CARS  
OBTAINABLE FROM JOBBERS & DEALERS  
CATALOGUE ON REQUEST

**KINZINGER BRUCE & CO. LTD.**  
NIAGARA-FALLS, CANADA  
SOLE MANUFACTURERS, UNDER  
LYON CANADIAN PATENTS.

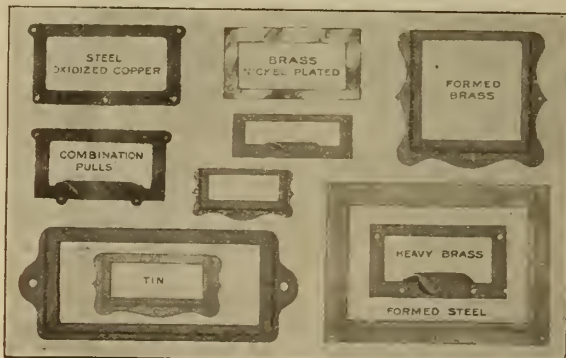

Stampings are lighter, stronger, more economical than castings. We design and manufacture our own dies for the production of stampings to meet any requirements. Send samples or blue prints for estimate.

Our Card Holders and Label Pulls—23 different styles—enable you to find what you want instantly. Send for our folder showing complete line, with sizes and dimensions.



### *Hindview* AUTO MIRRORS

—a profitable line for the accessory dealer. Every truck in Ontario must now be equipped with a mirror; motorists everywhere are realizing its convenience—and that it actually prevents accidents.

There is a "Hindview" for every type of passenger car and truck.

**Kales Stamping Co. Limited**

61 Walker Road

Walkerville, Ont.

## Can you sell the best rural water system on the market

You would promptly say, "Yes", if you saw **Westco Tankless Water System** in operation. Simplicity coupled with thoroughness, low price, low cost of installation and low cost of upkeep, make **Westco** by long odds the best rural water system proposition ever offered Canadian dealers.

? Here are a few Westco advantages:

- Has large capacity.
- Costs less to install.
- Costs less to maintain.
- Costs less to operate.
- Eliminates tank troubles.
- Is entirely automatic.
- Is absolutely dependable.
- No tank.
- No valves.
- No gears.
- No belts.
- No springs.
- No oil or grease cups.
- Self lubricating.

There is a "WESTCO" Pump for every requirement. Built in all sizes.

Write for particulars.

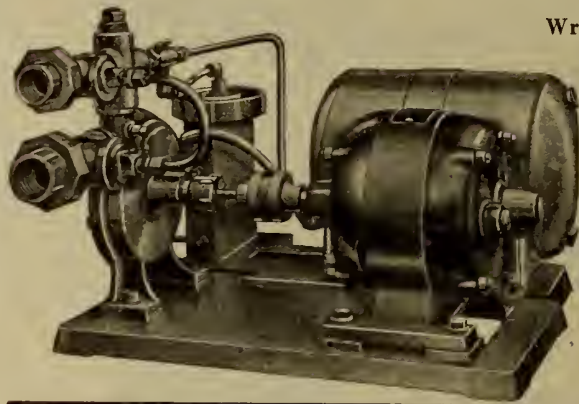

### WESTCO PUMPS LIMITED

707 Yonge St., Toronto

All there is to the entire system is what you see in this illustration—the Westco pump, motor, automatic electric control switch, a compression chamber, and necessary fittings and connections. No more simple and compact water system could be imagined.

MADE IN CANADA

TO THE TRADE



### Distributors Wanted for Spedolene

The all year lubricant, manufactured especially for the lubrication of transmissions, differentials, bearings, universal joints, etc., in

Motor Cars, Trucks and Farm Tractors

Manufactured by

**Spedolene Refining & Manufacturing Co. Limited**

MONTREAL

CANADA

WE WANT AGENTS

### Big Profits--Quick Sales

Write for Proposition

### Streamline Hood

For old style previous to 1917

### Ford Cars

This Hood on a 1915 Ford. Note the up-to-date appearance

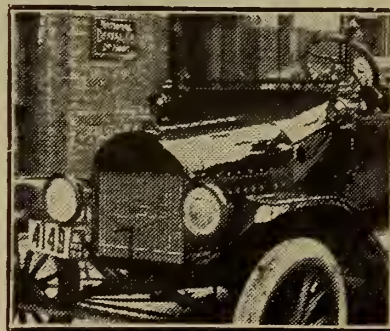

The Burrows Mfg. Co., 611 King St. W., Toronto, Ont.



# BIGGER BUSINESS FOR 1920

Do you realize, Mr. Dealer and Garage Man, to what extent the Automobile, Truck and Tractor have increased in usefulness? They have become of vital importance to the economic life of every community.

It is estimated that at the end of 1920, Canada will have close to 500,000 Motor driven vehicles on her highways. Think of the tremendous business possibilities the sale of Automotive Equipment and supplies offers dealers.

The Hyslop line is the logical dealers' line. It offers the best medium to meet the ever increasing demand for equipment and supplies from car owners. It comprises the largest and most comprehensive assortment of quality goods on the market, that will pay you handsomely to stock, giving you generous profits, quick turnovers and satisfied customers. Get in touch with us right now.

Make us your headquarters for equipment and supplies and prepare for the bigger business for 1920.



**Newtone Motor Driven Electric Horn**

The mechanism of this motor-driven horn is most efficient and simple of operation. When connected to a storage battery it emits a very loud, but pleasant sound. Black enamelled finish, nickel bell. Furnished complete with cable and round push button switch. A very high grade outfit throughout.

No. 5279—Price .....\$9.25

**Billmont Wrench Bull-Dog Grip—Never Slips**

The Billmont, with its curved nose, will slip into heretofore inaccessible places, take a bull-dog grip on nuts or bolts and turn off the hardest. Once on the nut it will not slip because the knurled outer casing gives you a firm hand grip.

Set consists of 5 hexagon sockets of unusual sturdiness, sizes 7-16, 1/2, 9-16, 19-32, 5/8 and one adapter (so you can use any standard 1/2 inch square shank socket).

No. 6055—Price, Billmont Master Wrench Set, complete .....\$15.00



**Marquette Tire Tool**

No. 6056  
Price.....\$4.00

How many times have you wished for a tool that would grip a tire without tearing it—pull it from the rim in an instant; and as quickly and easily put it back on again. Getting a tire off and on is the hardest, dirtiest, most exasperating work about a car. The Marquette Tire Tool makes it one of the simplest. Every car owner wants one, needs one and will buy one if you carry them in stock. Full directions in each tool.

**BILLMONT MASTER WRENCH**  
"The Wrench that Spins'em off"

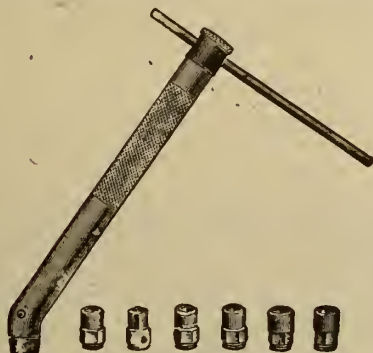

**Steel Luggage Carrier**

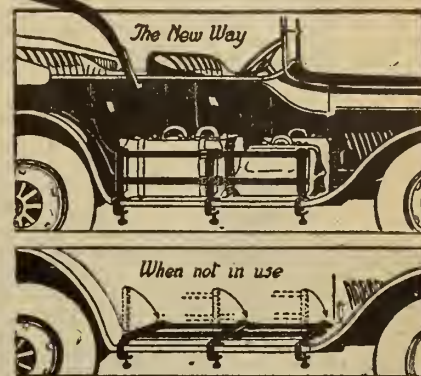

Carries bundles and suit-cases safely and without shifting, and where they will be out of the way. Attaches securely to running-board by hand-operated thumb-screws. Folds down flat when not in use and is hardly noticeable.

No. 5341—Price .....\$6.75

Dealers: Send for Our 1920 Catalogue — Order by Catalogue Number

**HYSLOP BROTHERS LIMITED**  
Shuter and Victoria Streets, Toronto

## Why Not Sell---The Best Socket Wrenches--- "HEXALL"

Trade Mark Reg. U.S. Pat. Off.

EVERY reason in the world why you should. Both from your own standpoint and that of your trade.

"HEXALL" Socket Wrenches have every advantage of the ready-seller---Quick and Frequent Turnover; Good Margin of Profit; Less Selling Effort. *It's a big "repeat" line.*

Experience shows that trade ties up to the house that sells "HEXALL" because the trade knows that "HEXALL" gives 100% service and satisfaction. Thus, the house that carries "HEXALL" enjoys increasing prestige with its trade ---which is a mighty desirable asset for any business.

"HEXALL" Ratchet Socket Wrench No. 2—11 pieces



"HEXALL" Socket Wrench No. 5—8 pieces.



"HEXALL" Ratchet Socket Wrench No. 1—16 pieces

The best Socket Wrenches in the world---yet "HEXALL" is sold under this Guarantee of

Faith:—

**"Break Any Sedgley Wrench and We Repair It--- No Charge"**

Why not push a line like that? If you are a dealer, get a "HEXALL" set---any one of the seven sets---from your jobber to-day. Then test it out thoroughly for quick and lasting service. If you are a jobber, write us.

*It takes experience and skill of no mean order to make tools as mechanically perfect as "HEXALL."*

**R. F. SEDGLEY, Inc., Est. 1897**

Also Makers of "BABY" Hammerless Revolvers.

2311-13-15 North 16th St., PHILADELPHIA, PA.

Canadian Distributors: Lamontagne, Limited, Montreal, Canada.

HAROLD F. WATSON CO., Sole Agent, 208 Coristine Building, Montreal, Canada





# There is No Time Like the Present to Seize this Opportunity

*The Dominant Line of Potato Machinery in Canada is the*

## O-K CANADIAN

including **PLANTERS, SPRAYERS and DIGGERS**



O.K. Canadian 2-Row Sprayer Operated by Hand.

Implement Dealers and Agents, it will pay you to write us **TODAY** about our selling proposition

O-K CANADIAN Planters have been in use for years and have given universal satisfaction. They save time, money and labor and are simple to operate and easy to keep in repair.

O-K CANADIAN Sprayers, two-row and four-row and the O-K-SPRA, provide a variety from which can be selected a sprayer for any size field and one that will meet every requirement.

O-K CANADIAN Diggers have solved one of the biggest problems of potato farming. Wherever used they have brought excellent results as dozens of letters from owners testify.

O. K. Canadian Digger No. 1 Going Over the Top



These lines are being advertised extensively all over Canada. Dealers should get in touch with us at once and reap the benefit of this campaign.

O-K CANADIAN Potato Machinery is guaranteed against any defects. The best class of workmanship, the strongest and most durable materials and the most modern features obtainable are all combined in the construction of these machines.

Send for full particulars to-day.

**Canadian Potato Machinery Co., Limited**  
59 Stone Road, Galt, Ontario

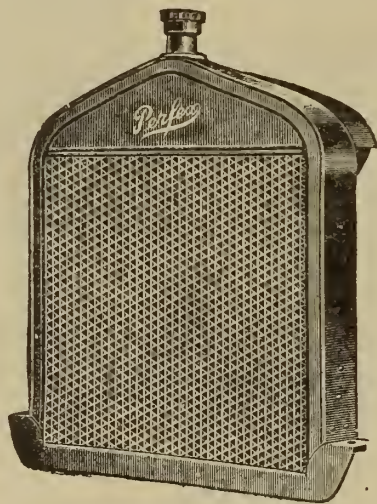

# PERFEX

*The Perfect Radiator*

Perflex radiators for Fords are a quality product embodying features that cannot be had in other radiators.

A patented spring bracket suspension and a real radiator core of great efficiency.

*The last word in Radiator construction*

**Perflex Radiator Co., Racine, Wisconsin, U.S.A.**

**P. A. C. McINTYRE & COMPANY**  
311 Confederation Life Building, Winnipeg  
Direct Representatives for

Manitoba, Saskatchewan, Alberta and British Columbia



*Tool Locked in Position for Removing or Replacing Tire*

## K.P. Universal Rim Tool

### The Easiest Way to Remove Tires from Split Rims

Fits all types of cross-cut demountable rims in use to-day.

Collapses a rim no matter how badly a tire may be stuck to it.

Forces the rim back on the tire again with the utmost ease even in the case of new tires which are under-sized.

Locks rim collapsed while tire is being removed or replaced.

**Price \$6.00**

**The K.P. PRODUCTS COMPANY, Inc.**  
250 West 54th Street, NEW YORK, N.Y.

Sold by

**Northern Electric Company**  
LIMITED

Montreal Quebec Toronto Winnipeg Calgary Vancouver  
Halifax Ottawa London Regina Edmonton



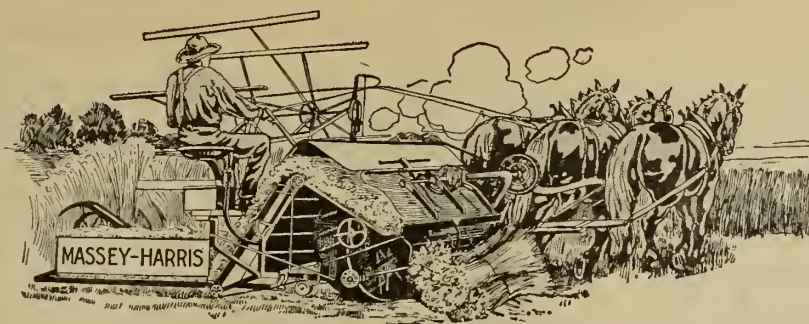

## BINDING THE SHEAVES

Binding the sheaves is but one of the many acts so effectively accomplished by Massey-Harris Binders. For three generations, it has bound farmer to agent, agent to manufacturer, by standing up under the most exacting requirements.

Convenience of operation, lightness of draft, simplicity, reliability, and durability are responsible for the wide-spread popularity of Massey-Harris Binders.

Twenty-three special features to aid the dealer who handles Massey-Harris Binders. Twenty-three special features to help the farmer who buys one.

Applications for representation in vacant territories should be addressed to the Manager of the Branch nearest you.

**MASSEY-HARRIS COMPANY, Limited**

Head Office - Toronto, Ont.

AGENCIES EVERYWHERE

WE GIVE

**“Quality and Service”**

IN

**TRACTOR and TRUCK  
STEEL CASTINGS**

**JOLIETTE STEEL CO., LIMITED**

Tel. Main 402  
9th Floor Read Building,  
Montreal, Que.

**JOLIETTE,  
P.Q.**



**SAYS THE MASTER MECHANIC:** The Greb Automatic Grip Puller is a One-Man Puller—Quick-acting, strong and simple in the extreme. May be locked in any desired position. A combination of two or three arms. Heavy Duty Size capacity 1" to 18"—Junior Size capacity 1/2" to 7". Two sets of jaws furnished with each size.

**TEN DAYS' TRIAL.**—If you dealer or jobber does not have them we will send you one. Try it ten days. If not satisfactory, return to us and we will refund your money. We also make the GREB RIM TOOL.

**THE GREB COMPANY, 319 State St., BOSTON**

**WANTED—CLERICAL POSITION,** preferably Private Secretary, by young married man, Canadian, experienced accountant, shorthand writer and typist. Have completed the Gas Engines Course of the International Correspondence Schools. Best references. Address Box 566, Lethbridge, Alberta.

For repairing cracked water jackets, cylinder heads and split gas pipes, use

**ALUMALL METAL**

the greatest crack filler known. Thousands of garages using it now, with great satisfaction. \$6.00 a box.

Sold Exclusively by

**Geo. W. Anstett, - McGee, Sask.**

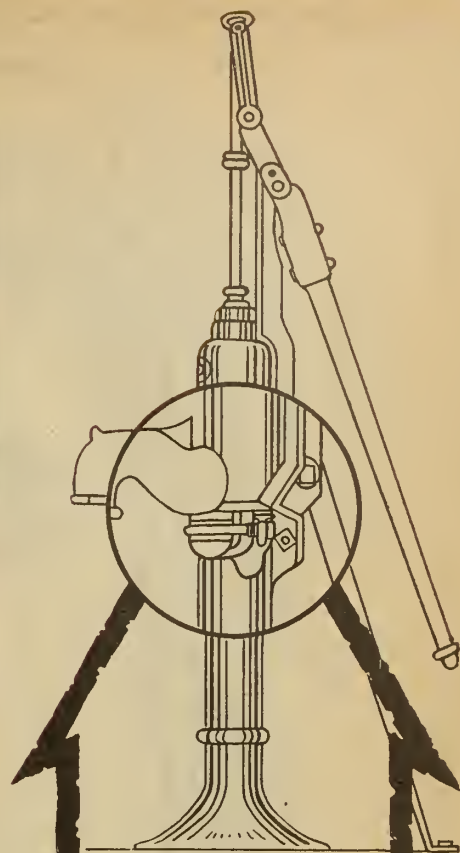

## See the Clip!

This is a patented and most valuable feature of BT Ready-To-Ship Pumps. It makes it easy to instal or repair the pumps. The spout and head can be removed from the stand, yet, when clipped together, the joint is as firm as a solid standard.

It's easy to attach the head to pipe and pump rod. You can always get at the joint between suction pipe and spout—even if it rusts in.

*No other pumps have this feature.*

**Beatty Bros., Limited**

Fergus, Ont.	St. John
Montreal	Winnipeg
Vancouver	Edmonton
London, Ont.	London, Eng.

Well  Pumps



## Dairy and Household Supplies

### H. M. THE KING INSPECTS CANADIAN WASHER EXHIBIT

CANADIAN-MADE washing machines created a great deal of interest at the Ideal Homes Exhibition held recently in London, England.

Great crowds gathered round the demonstration throughout the exhibition.

A most interesting occurrence during the exhibition was a visit to the



H.M. The King views Canadian exhibit.

Beatty Bros.' exhibit from H.M. the King. Our illustration shows a view of his Majesty inspecting the washers and Mr. Roy B. Stewart, manager in London for Beatty Bros., Limited, Fergus, Ont., demonstrating them. The King expressed great pleasure on hearing that these machines were a Canadian product, and asked a number of questions regarding the mechanical parts and the working qualities.

One unique feature of the occasion was that the demonstrators worked in evening dress—a somewhat unusual garb in which to demonstrate washing machines.

### KOHLER FARM LIGHTING PLANT

THE Kohler automatic power and light is a plant designed specially for the farm. It is of the automatic type, having a four-cylinder, four-cycle gasoline-burning engine, equip-

ped with an automatic mechanical governor. This makes unnecessary any trips to start or stop the engine; in fact, the makers say the plant need not be visited more than once a month to replenish oil and water.

The mechanism which controls the automatic start and stop is found in a black metal box mounted on the generator. The switch control is surprisingly free from complications usually thought necessary to secure automatic operation. The mechanism operates through the well-known principle of electric solenoid and the force of gravity. When the plant leaves the factory, the switch box is sealed and with it goes the company's guarantee, providing the seals are not broken.

The Kohler automatic produces standard 110 volt current. This higher voltage enables current for power purposes to be sent to the farthest buildings of a scattered farm or estate. Because of the standard voltage, wiring costs are reduced to a minimum, standard No. 10 wire being used for most purposes.

The feature of this plant is its freedom from storage batteries. Only a small automobile-type of battery is used, this solely for automatic starting. This battery is kept automatically charged and is always ready for starting. Current from the generator goes direct to the line.

The plant is thermo-syphon water cooled, and is equipped with an automobile type radiator, holding 1½ gallons of water. It is lubricated by strained oil forced under pressure by a pump located in the oil base to main and rocker arm bearings. The connecting rod and piston pin bearings are oiled by splash. This plant is manufactured by the Kohler Co., Kohler, Wisconsin.

### SWEDISH SEPARATOR CHANGES

J. A. NOREN has been appointed service manager over all the United States and Canada for the Swedish Separator Company. Mr. Noren has



Kohler Farm Lighting Plant.

had wide experience in the separator business, and knows the difficulties that confront the separator dealer.

The Swedish Company also announce the appointment of Cyrus A. Wood, formerly of Swift and Company, as manager of Sales Promotion

had wide experience in the separator business, and knows the difficulties that confront the separator dealer.

The Swedish Company also announce the appointment of Cyrus A. Wood, formerly of Swift and Company, as manager of Sales Promotion

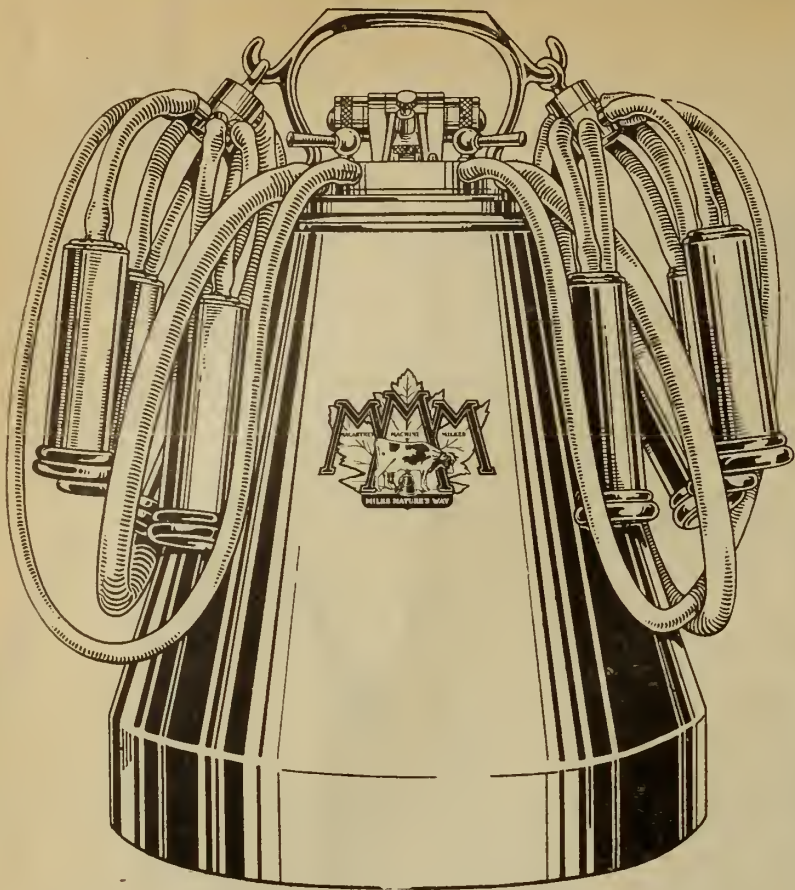

"THE COW'S ADOPTED CHILD"

## Get Your Agency Now

Be one of the live dealers who are securing exclusive territory representation for the Macartney Machine Milker—the 100% efficient, dependable and durable milking machine.

You will find our dealer proposition more than usually appealing. Co-operation and Service are back of every Macartney representative. Machines are sold to dealers on 60 days dating. Good farmers' notes are accepted in settlement of accounts and a cash commission on all such notes is forwarded the dealer.

The Farmers and Dairymen in your locality are reading Macartney Machine Milker advertising now appearing in the leading farm and dairy journals. This publicity will mean big business and good profits for Macartney agents. Will you be one of them? Now is the time to decide.

Write to-day!

The  
**Macartney Milking Machine Co.**  
LIMITED

316 Catherine St., Ottawa



# De Laval business policies

*which have contributed largely  
to the leadership and success  
of the Company and its agents*

FIRST: The production of the best possible machine for the separation of cream from milk through the employment of the most skilled centrifugal engineers and the best workmanship and materials.

SECOND: An appreciation of the fact that the cream separator is a high speed machine requiring a refinement of construction and a standard of manufacturing methods far superior to those found in any agricultural implement.

THIRD: A policy of distribution of its merchandise through dealers that is mutually fair and equitable. A policy which guarantees satisfactory service to the user and a reasonable profit to the dealer.

FOURTH: The progressive determination to make De Laval Separators better every year, and to make the advertising stronger and better every year.

FIFTH: To propagate and support movements that promote the success of the dairy industry as a whole.



**If you are in sympathy with these policies and would like to arrange for the sale of the best as well as the easiest selling separator on the market, write to our nearest office**

**The DE LAVAL COMPANY, Ltd.**

Montreal Peterboro Winnipeg Edmonton Vancouver

*50,000 Branches and Local Agencies the World Over*



# "Built to Build Goodwill"

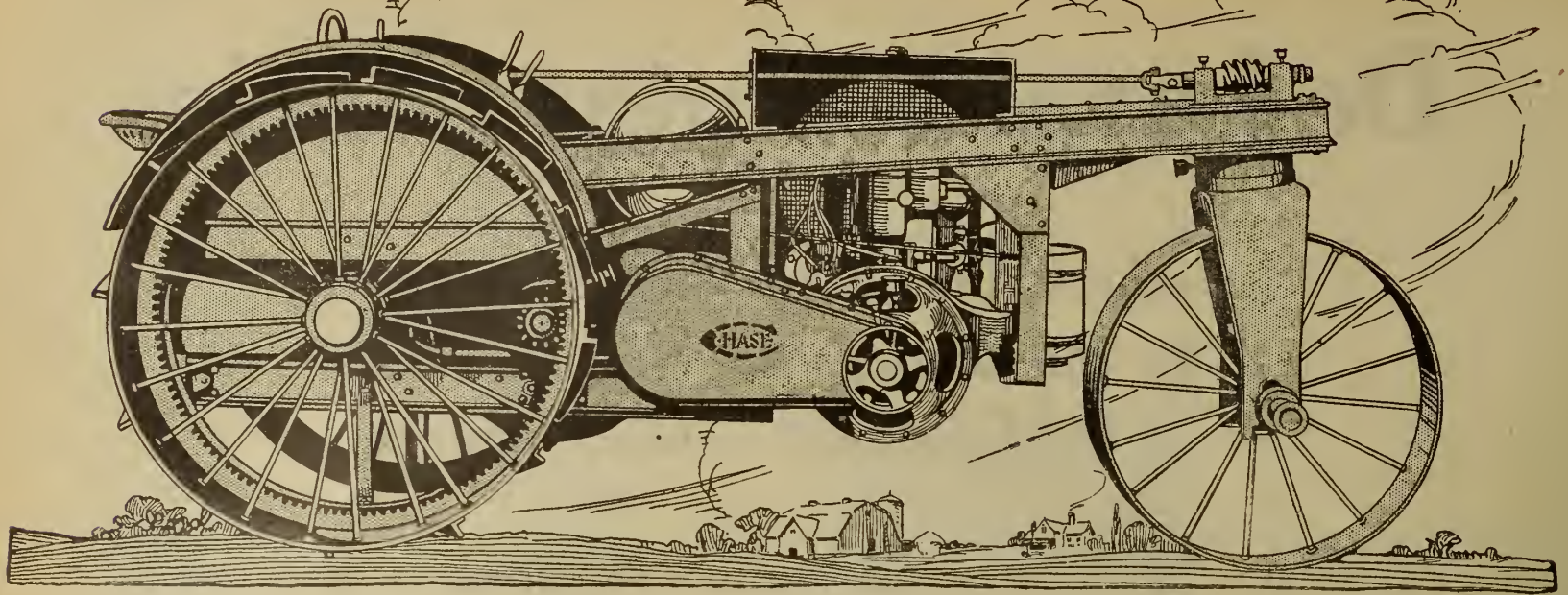

## The Tractor without Differential Gears

A tractor has no more need for differential gears than it has for a fly-net.

Those gears serve no good purpose in a tractor. And they do cause constant trouble, rob the motor of power, and shorten the life of the tractor.

The Chase Tractor has no differential gears.

The two rear wheels get equal driving power, turn over at equal speed, apply the force of the heavy-duty motor at its full efficiency.

That means that when the Chase gets into a hole, both rear wheels work to pull it through. When obstacles are met the Chase rides over them. In plowing on the level or on sidehills, the side-draft does not pull the Chase off its true course.

The Chase, therefore, avoids a very common tractor trouble.

### A trouble-maker avoided

Tractors with differential gears can do their best work only on a straight-way pull on level land. The moment one wheel meets an obstacle, the differential throws all the power into the other wheel. So quite often you see such a tractor with one rear wheel dead and the other spinning. That happens when the tractor gets one wheel in a mud hole. The very time when extra driving force is needed the differential gears rob the motor of its power to move the tractor.

The same thing occurs in a lesser degree in all plowing work. For the side-draft tends to place more load on one wheel than on the other and the differential gears throw the

power into the other wheel. **The tractor with differential gears is more than half of the time a one-wheel-drive tractor.**

The Chase Tractor, having no differential gears, is always pulling evenly on both rear wheels.

For that reason it operates with less power and so saves kerosene.

### Gears waste power

But there is another saving of gas from this same feature of Chase construction. Differential gears rob a motor of about 10% of its power. 10% that does the tractor owner no good. The Chase saves that 10% because it has no differential gears.

### The even pull saves money

Pulling evenly the Chase wears evenly. Lasts longer. Requires less adjustment of bearings. Needs fewer repairs. And, for that reason, stays more steadily "on the job."

As a practical man can see, the whole of the Chase Tractor gives proof of the same sensible, common-sense idea of design in every part of its construction.

Watch it in action and you will see in the smooth-working Chase a quality that you expect only in a high-grade, perfectly-adjusted machine.

### Built to build goodwill

Canadians build the Chase—in Canada. Canadians build the Chase that is sold in Great Britain and foreign lands—yes, and also in the United States. The Chase institution was created to establish in Canada a world-wide tractor business founded on Canadian principles of

doing business. The men behind it, R. J. and W. J. Cluff, are men with high manufacturing ideals. They are exacting in their demands. They want the men who buy Chase Tractors to make money out of them. They are determined that every customer shall receive the service he requires to keep his Chase Tractor always at its best and always "on the job."

### Investigate our service

You will find it to your advantage to deal with an institution with these ideas of service. You will find that the Chase Tractor is a piece of machinery that will gladden your eye. If you haven't seen it, be sure to do so. Or, write for illustrated literature and detailed information. We will send it promptly and tell you where you can see a Chase Tractor.

### SPECIFICATIONS

**Motor**—Buda Model H.T.W. Heavy duty, Tractor type 4 cyl. 4¼" bore, 5½" stroke. Set cross-wise of frame. Every part readily accessible. Extra large water passages for cooling. Force-feed lubrication, thorough vaporizing of low-grade fuels. Heated and "water washed" air.

**Fuel**—Specially designed to burn Kerosene or low-grade gasoline.

**Drive**—No differential gears are used, the drive being direct from the transmission to outer rim of wheel through bull pinions and gears. Both bull pinions and bull gears cut from forged steel and case-hardened.

**Transmission**—Fully enclosed and running in oil. Hyatt roller bearings. Very simple type. Gears accurately machined from high grade steel.

**Chain Drive**—Power is delivered to the transmission gears by a wide chain fully encased and running in oil.

**Belt Pulley**—In direct line with crankshaft—no bevel gears. Located at side—best position for lining up with the machine to be driven.

**Control**—Driver has unobstructed view. Control levers are simple and easy-working.

**Turning-radius**—12 feet circle.

**CHASE TRACTORS  
CORPORATION LIMITED  
TORONTO - ONTARIO**

# CHASE TRACTOR



# Northern Electric POWER and LIGHT

*A Complete Line of  
Electric Farm Plants  
and Accessories*

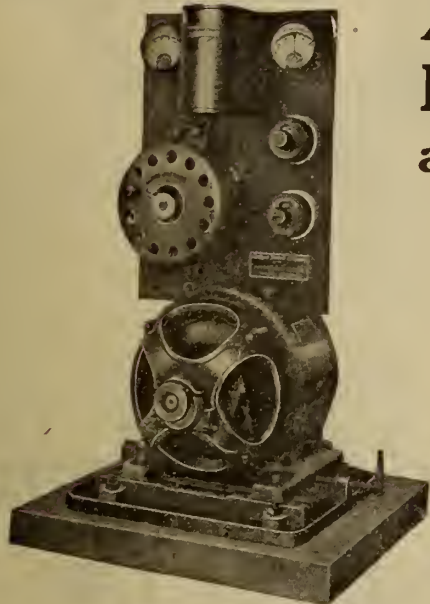

Belt-connected Plant — operates from any good engine

- Belt Connected Plants
- Direct Connected Plants
- Water Systems
- Portable Motors
- Farm Accessories
- Wires and Supplies

This line will make you the Electrical Headquarters of your District.

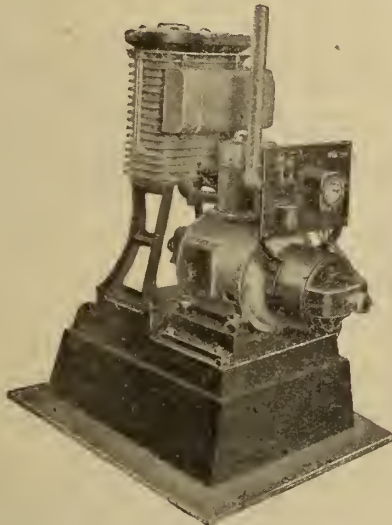

Direct Connected Utility Plant  
¾ K.W.—32 Volt



Automatic Water System, showing Tank, Pump and Motor. Capacities 100 to 1400 gals. per hour

¶With the plant you can usually sell a Water System, while limitless follow-up sales possibilities are yours with Utility Motors, Electric Churns, Vacuum Cleaners, Washing Machines, Dishwashers, Irons, Toasters, Percolators, Wiring Devices of all kinds, Fixtures, etc.

Write Our Nearest House Now

Be the Farm Electrifier of Your District

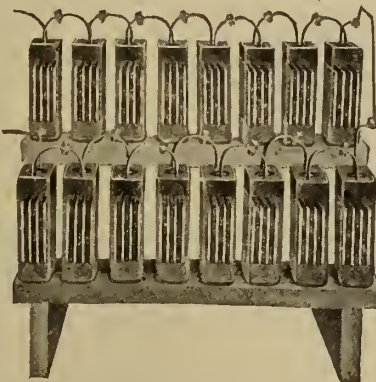

Titan Storage Battery, 16 cells supplied with each plant. 110 or 200 Ampere Hours

## Northern Electric Company LIMITED

MONTREAL    OTTAWA    LONDON    WINNIPEG    EDMONTON    VANCOUVER  
HALIFAX    TORONTO    QUEBEC    REGINA    CALGARY

**It may cost you money**

to ignore the advertising  
Somebody might be selling a new, better, more economical food; or a utensil that would save money and time; or an article that would add greatly to your comfort and well-being; or some better material for making shoes or clothing—but you would never know it.

**Broughton's Blowout Boots Bind Bad Breaks and Bruises Best**

Made of Steel  
For any automobile tire weakness

Hold in the lump.  
And stop the bump.



THE GEO. H. BROUGHTON CO., Mfgs.  
122 Wellington Street West, Toronto, Ontario



**AUTOMOBILE SPRINGS**

The Guelph Spring and Axle Co.

Guelph, - Ontario  
Manufacture

**AUTO SPRINGS  
ALL KINDS  
HIGHEST QUALITY**

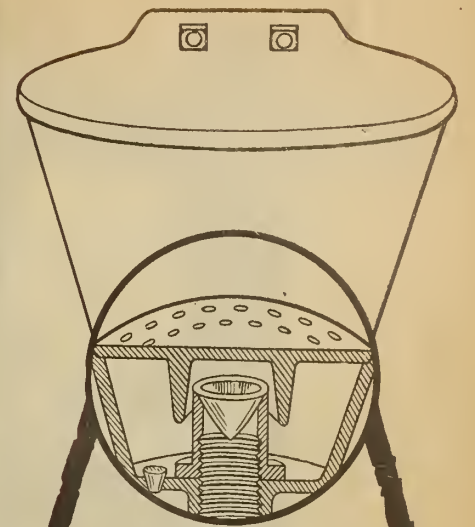

# Wont' Clog

You want the Water Bowl Outfits you sell to give satisfaction.

They won't, if the pipes clog up. That means worry for you and the farmer.

Straw, sediment and chaff cannot get back into the pipes with BT Water Bowls. The patented aluminum valve makes it impossible.

The BT Bowls can be cleaned in a minute, by removing the rubber plug and rinsing the bowl.

Write us for full particulars.

**Beatty Bros. Limited**

Fergus, Ont.    London, Ont.  
Winnipeg    Edmonton  
Montreal    St. John  
Vancouver    London, Eng.

Water  Bowls



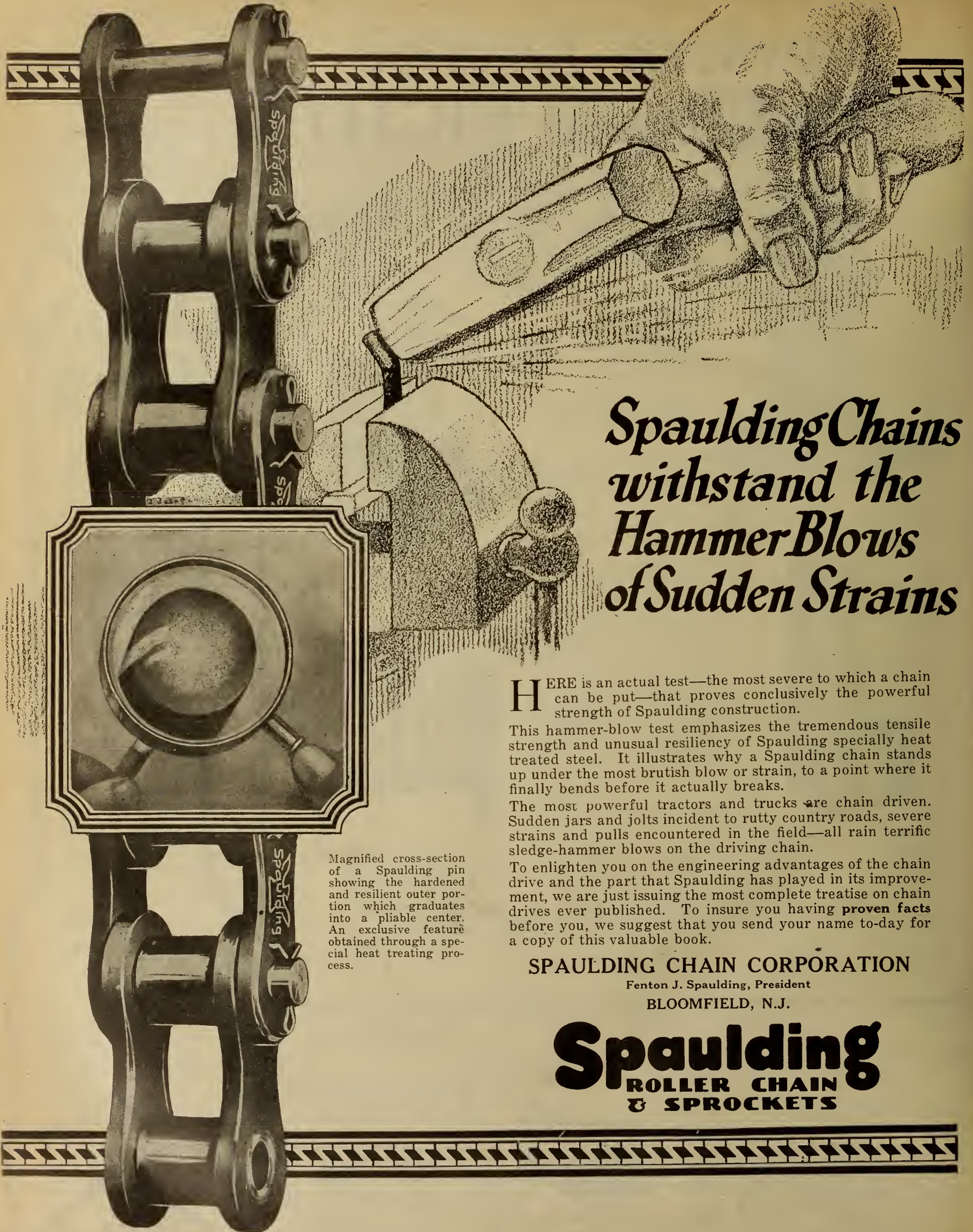

## Spaulding Chains withstand the Hammer Blows of Sudden Strains

**H**ERE is an actual test—the most severe to which a chain can be put—that proves conclusively the powerful strength of Spaulding construction.

This hammer-blow test emphasizes the tremendous tensile strength and unusual resiliency of Spaulding specially heat treated steel. It illustrates why a Spaulding chain stands up under the most brutish blow or strain, to a point where it finally bends before it actually breaks.

The most powerful tractors and trucks are chain driven. Sudden jars and jolts incident to rutty country roads, severe strains and pulls encountered in the field—all rain terrific sledge-hammer blows on the driving chain.

To enlighten you on the engineering advantages of the chain drive and the part that Spaulding has played in its improvement, we are just issuing the most complete treatise on chain drives ever published. To insure you having **proven facts** before you, we suggest that you send your name to-day for a copy of this valuable book.

**SPAULDING CHAIN CORPORATION**

Fenton J. Spaulding, President

BLOOMFIELD, N.J.

**Spaulding**  
ROLLER CHAIN  
& SPROCKETS

Magnified cross-section of a Spaulding pin showing the hardened and resilient outer portion which graduates into a pliable center. An exclusive feature obtained through a special heat treating process.



# Hold Tite Nut Lock

*For Automobiles, Trucks, Tractors, Stationary Engines  
and all kinds of Agricultural Implements*

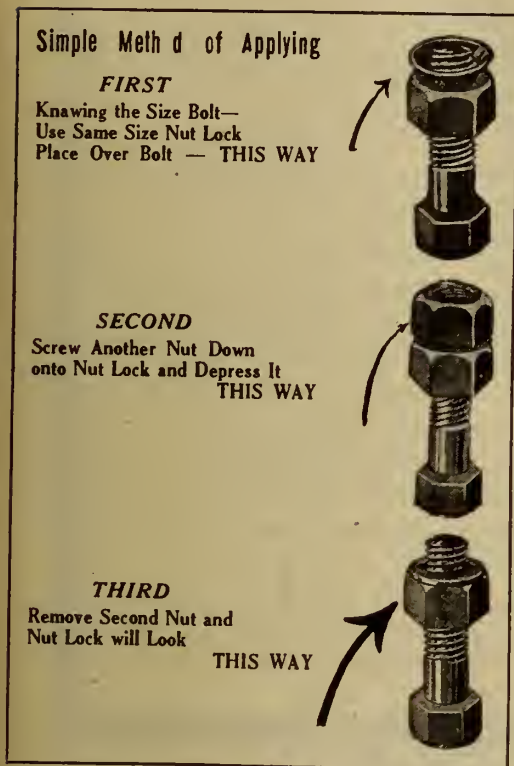

## The LATEST and LAST In a NUT LOCKING DEVICE

No vibration will loosen it, a little collar of steel that costs little, but has big efficiency.

No extra nut, no cotter pin needed with the Hold Tite Nut Lock—it saves their cost.

No thought need be given to the shape of the nut or to the thread of the bolt. Fit the right sized Nut Lock over the same size bolt,—that's all.

### Mr. Dealer

This Nut Lock makes each bolt as secure as a rivet. Why not put it on the Automobiles, Trucks, Stationary Engines and all kinds of Agricultural Implements that you sell. It will keep the joints tight long after machines without them have become like rattle boxes.

These inexpensive, yet positive nut locks, will give greater satisfaction to customers and bring you bigger business.

Some of the  
Satisfied Users of  
the Hold Tite  
Nut Lock

Montreal Trams-  
ways Co.

King Warden, Ltd.

Foss Machinery  
Company

Dominion Oilcloth  
Co.

Canadian National  
Railways

Dominion Sugar  
Co., Chatham,  
Ont.

Ottawa Electrical  
Railway Co.

Dominion Furni-  
ture Co., St.  
Therese, Que.

Canadian Transfer  
Co.

Canadian Consoli-  
dated Rubber  
Co., Kitchener,  
Ont.



The Nut Must Stay Tight  
It Cannot Work Loose

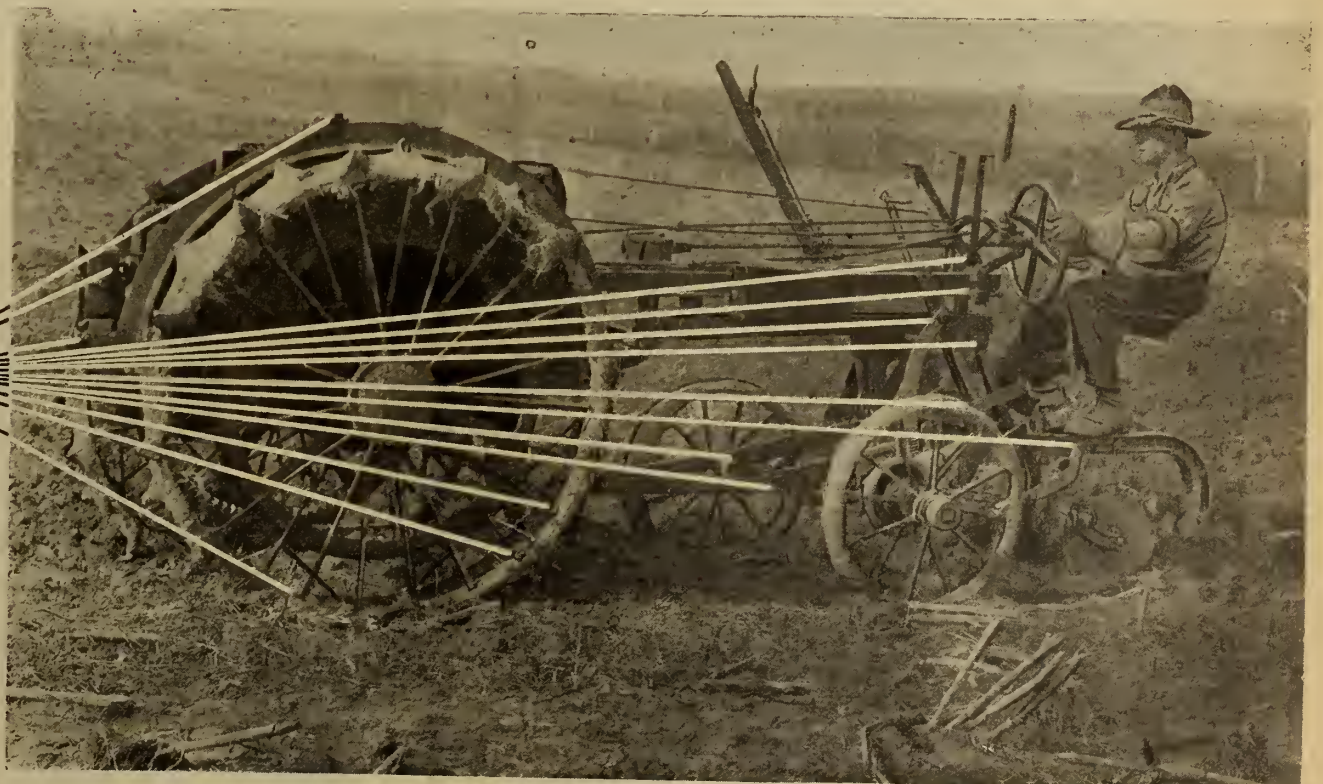

Write to-day for full particulars to

**EDWARD A. ROBINSON CO., LIMITED**  
228 CRAIG ST. W., MONTREAL

Canadian Offices: Bank of Toronto Chambers, 205 Yonge St. Toronto, Ont 322 McIntyre Block, Winnipeg, Man. American Factory: 166 Montague Street, Brooklyn, N.Y.



# TURNER

## Simplicity

### There's No Guesswork When You Sell a Turner

When you sell a Turner Simplicity you don't have to "guess" what it will do. The Turner has been tried out and has given satisfaction on all kinds of farm work. Every Turner that you sell will work to its full rated capacity under all farm conditions.

The Turner is so simple and fool-proof that any farmer boy can operate it and take care of it. It is a practical tractor that is large and powerful enough to do all the work about the farm, and economical enough to run on light work as well.

These are the features that are assisting dealers who sell Turner Simplicity to build up a growing and profitable tractor business—standard design, simple control, three point suspension, Hyatt Roller Bearings, enclosed parts, short turning radius, low center of gravity, light weight, and great strength.

It will pay you to write at once for full particulars of the Turner Line.

Turner Tractor Sales Co.      Power Farm Machinery Co.  
Winnipeg, Man.                      Edmonton, Alta.

Turner Mfg. Co., 441 Lake St., Port Washington, Wis., U. S. A.

*Builders of Turner Tractors and Simplicity Farm Engines*

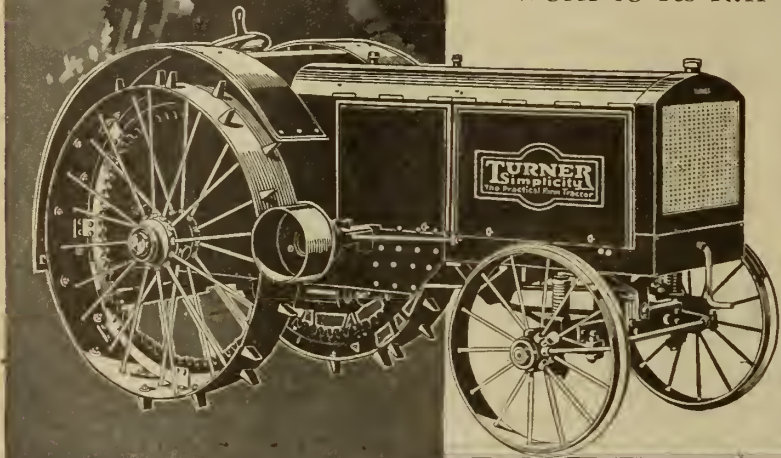

### Mr. Dealer ——— You're the Doctor!

You know that your customers have engine troubles on account of carbon—and we know those troubles can be cured. Here is the medicine that does the work—



## CARBON REMOVER

IT DOES NOT CUT COMPRESSION.

We are telling motorists about D-B through extensive advertising, and they will be asking for it. Will YOU help fill the demand?

You may conscientiously sell D-B as a real "carbon cure"—and there is money in it for you. Write for dealer's proposition.

### Auto Jack says:

To keep your engine healthy, keep it clean. Don't let carbon accumulate. A good engine laxative, such as D-B, will remove carbon harmlessly via the exhaust, and keep the engine clean and efficient.

The Dust Bane Mfg. Co. Limited  
Ottawa, Ont.



*Aikenhead's*  
"The Sign of Better Service"

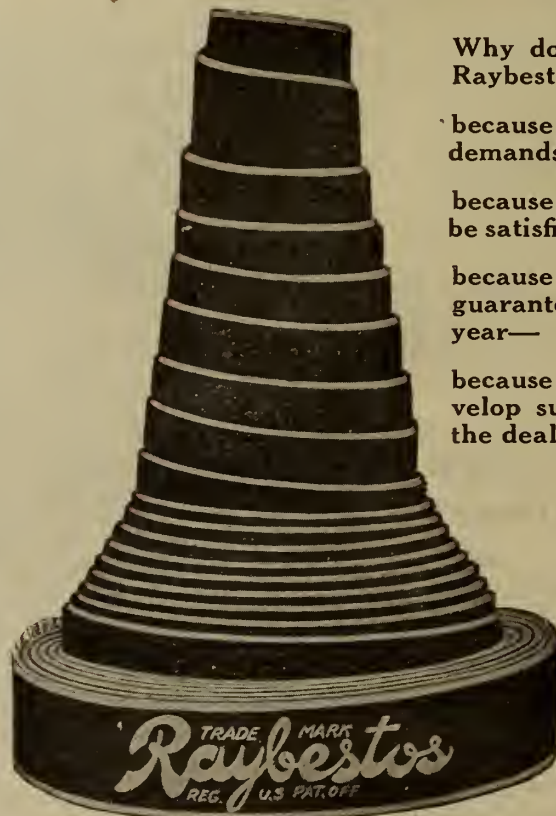

Why do 20,000 dealers sell Raybestos Brake Lining?

because the motoring public demands good brake lining—

because the owner is sure to be satisfied with the service—

because it is the only lining guaranteed to wear one year—

because all these factors develop substantial profits for the dealer.

That's  
the  
Answer

Aikenhead Hardware Co.  
Toronto - Canada



# POWER, LOW UPKEEP, LONG LIFE

BUILT IN CANADA



A truck will produce according to the power of endurance built into it—the Veteran performance is just as sure, the Veteran's power of endurance just as certain as brains, money and materials can make them.

SOME GOOD TERRITORY STILL OPEN

EASTERN CANADA MOTOR TRUCK CO., LTD.  
HULL, - QUE.



# CANADIAN Motor Tractor and Implement Trade Journal BUYERS DIRECTORY

This directory will help you with your buying and your planning. The advertisers listed here are thoroughly reliable and leaders in their respective fields. They are looking for live, wide-awake representatives. Study their advertisements carefully because they contain valuable information which will dovetail with your plans. We are glad to go to the trouble of arranging this list—to make it easy for you to select new lines. If it so happens that what you want is not here, write us, and we will tell you where to get it.

## ACCESSORIES

British & Foreign Agencies, Montreal.  
Dustbane Mfg. Co., Ltd., Ottawa.  
Geo. W. Anstett, McGee, Sask.  
G. H. Broughton & Co., Toronto.  
Guelph Spring & Axle Co., Guelph.  
Holton Hood Clip Co., Windsor, Ont.  
Lions Ignition Co., New York City.  
Northern Electric Co., Ltd., Montreal.  
The Goodyear Tire & Rubber Co. of Canada, Ltd., Toronto.  
Apollo Plug Mfg. Co., Birmingham, Eng.  
R. F. Sedgley, Inc., Philadelphia, Pa.  
The Burrows Mfg. Co., Ltd., Toronto.  
Can. Fairbanks-Morse Co., Ltd., Montreal.  
Kales Stamping Co., Detroit, Mich.  
Kinzinger Bruce Co., Niagara Falls, O.  
The Greb Co., Boston.  
Aikenhead Hardware Co., Toronto.  
Hyslop Bros., Toronto.  
Fyrac Mfg. Co., Rochfort, Ill.  
K. P. Products Co., 250 West 54th St., New York City.  
Perfex Radiator Co., Racine, Wis.  
Robinson Co. Ltd., Edward A., Montreal  
Windsor Machine & Tool Wks., Windsor

## AUTOMOBILES

Fiat, 501 Fifth Ave., New York.

## AUTOMOBILE CHAINS

Can. Fairbanks-Morse Co., Ltd., Montreal.

## BARN EQUIPMENT

Beatty Bros., Ltd., Fergus, Ont.

## BEAN MACHINERY

John Deere Mfg. Co., Welland, Ont

## BEET MACHINERY

International Harvester Co., of Can., Ltd., Hamilton, Ont.  
John Deere Mfg. Co., Welland, Ont.

## BINDERS

The Frost & Wood Co., Ltd., Smiths Falls, Ont.  
International Harvester Co., of Can., Ltd., Hamilton, Ont.  
Massey-Harris Co., Toronto.

## BELTING

The Goodyear Tire & Rubber Co. of Canada, Ltd., Toronto.

## BATTERIES

Can. Fairbanks-Morse Co., Ltd., Montreal.

## CARRIAGES

Cockshutt Plow Co., Brantford, Ont.

## CREAM SEPARATORS

De Laval Co., Ltd., Peterboro, Ont.  
International Harvester Co., of Can., Ltd., Hamilton, Ont.  
King Separator Co., Bridgeburg, Ont.  
R. A. Lister Co. (Canada), Ltd., Toronto  
Swedish Separator Co., Montreal.

## CEMENT MIXERS

Can. Fairbanks-Morse Co., Ltd., Montreal.

## CASTINGS

Joliette Steel Co., Joliette, P.Q.

## CORN HARVESTERS

Cockshutt Plow Co., Brantford, Ont.  
International Harvester Co., of Can., Ltd., Hamilton, Ont.  
Massey-Harris Co., Toronto.

## CORN MACHINERY

International Harvester Co., of Can., Ltd., Hamilton, Ont.  
John Deere Mfg. Co., Welland, Ont.

## CULTIVATORS

Cockshutt Plow Co., Brantford, Ont.  
John Deere Mfg. Co., Welland, Ont.  
Massey-Harris Co., Toronto.  
The Frost & Wood Co., Ltd., Smiths Falls, Ont.  
International Harvester Co., of Can., Ltd., Hamilton, Ont.

## CUTTERS

Butterfield & Co., Inc., Rock Island, Q.

## DAIRY SUPPLIES

International Harvester Co., of Can., Ltd., Hamilton, Ont.  
R. A. Lister Co. (Canada), Ltd., Toronto  
DeLaval Dairy Supply Co., Peterboro.

## DIES

Butterfield & Co., Inc., Rock Island, Q.

## DISCS

Massey-Harris Co., Toronto.

## DITCHING MACHINES

Can. Fairbanks-Morse Co., Ltd., Montreal.

## DRILLS

Massey-Harris Co., Toronto.

## DRILLS, TWIST

Butterfield & Co., Inc., Rock Island, Q.

## DRILLS, GRAIN

Cockshutt Plow Co., Brantford, Ont.  
International Harvester Co., of Can., Ltd., Hamilton, Ont.  
John Deere Mfg. Co., Welland, Ont.  
The Frost & Wood Co., Ltd., Smiths Falls, Ont.

## ENGINES

Can. Fairbanks-Morse Co., Ltd., Montreal.  
Gilson Mfg. Co., Ltd., Guelph, Ont.  
International Harvester Co., of Can., Ltd., Hamilton, Ont.  
John Deere Mfg. Co., Welland, Ont.  
The Frost & Wood Co., Ltd., Smiths Falls, Ont.  
Massey-Harris Co., Toronto.  
R. A. Lister Co. (Canada), Ltd., Toronto  
Renfrew Mchy. Co., Renfrew, Ont.

## ENSILAGE CUTTERS

Can. Fairbanks-Morse Co., Ltd., Montreal.  
Gilson Mfg. Co., Guelph, Ont.  
International Harvester Co., of Can., Ltd., Hamilton, Ont.  
Massey-Harris Co., Toronto.

## FEEDERS

John Deere Mfg. Co., Welland, Ont.

## FARM MACHINERY

Can. Fairbanks-Morse Co., Ltd., Montreal.  
Cockshutt Plow Co., Brantford, Ont.  
John Deere Mfg. Co., Welland, Ont.  
International Harvester Co., of Can., Ltd., Hamilton, Ont.  
Massey-Harris Co., Toronto.  
Can. Potato Mchy. Co., Galt.  
The Frost & Wood Co., Ltd., Smiths Falls, Ont.  
R. A. Lister Co. (Canada), Ltd., Toronto  
Gilson Engine Co., Guelph, Ont.

## FEED CUTTERS

Can. Fairbanks-Morse Co., Ltd., Montreal.  
Massey-Harris Co., Toronto.  
Gilson Engine Co., Guelph, Ont.

## FENCING

The Steel Company of Canada, Ltd., Montreal, Que.

## FINANCIAL

The Commercial Credit Co. of Canada, Ltd., Toronto.

## GRINDSTONES

S. Vessot & Co., Joliette, P.Q.

## GRINDERS

Can. Fairbanks-Morse Co., Ltd., Montreal.  
International Harvester Co., of Can., Ltd., Hamilton, Ont.  
Massey-Harris Co., Toronto.  
R. A. Lister Co. (Canada), Ltd., Toronto  
S. Vessot & Co., Joliette, P.Q.  
Gilson Engine Co., Guelph, Ont.

## HARROWS

Cockshutt Plow Co., Brantford, Ont.  
International Harvester Co., of Can., Ltd., Hamilton, Ont.  
John Deere Mfg. Co., Welland, Ont.  
Massey-Harris Co., Toronto.  
The Frost & Wood Co., Ltd., Smiths Falls, Ont.

## HAY LOADERS

International Harvester Co., of Can., Ltd., Hamilton, Ont.  
John Deere Mfg. Co., Welland, Ont.  
The Frost & Wood Co., Ltd., Smiths Falls, Ont.

## HARDWARE

Can. Fairbanks-Morse Co., Ltd., Montreal.  
Massey-Harris Co., Toronto.

## HAY RAKES

John Deere Mfg. Co., Welland, Ont.  
The Frost & Wood Co., Ltd., Smiths Falls, Ont.

## HAY CARRIERS

Beatty Bros., Ltd., Fergus, Ont.  
Massey-Harris Co., Toronto.

## HAY PRESSES

Birdsell Mfg. Co., Toronto.  
International Harvester Co., of Can., Ltd., Hamilton, Ont.

## HULLERS (Clover)

Birdsell Mfg. Co., Toronto.

## LIGHTNING RODS

Shinn Mfg. Co., Guelph, Ont.

## LIGHTNING SYSTEMS

Can. Fairbanks-Morse Co., Ltd., Montreal.

R. A. Lister Co. (Canada), Ltd., Toronto  
Northern Electric Co., Ltd., Montreal.  
Gilson Engine Co., Guelph, Ont.

## LIME AND FERTILIZER SOWERS

John Deere Mfg. Co., Welland, Ont.

## LUBRICANTS

Imperial Oil Co., Toronto.  
Spedoline Refining & Mfg. Co., Ltd., Montreal.

## MANURE CARRIERS

Beatty Bros., Ltd., Fergus, Ont.

## MANURE SPREADERS

Cockshutt Plow Co., Brantford, Ont.  
International Harvester Co., of Can., Ltd., Hamilton, Ont.  
John Deere Mfg. Co., Welland, Ont.  
Massey-Harris Co., Toronto.  
The Frost & Wood Co., Ltd., Smiths Falls, Ont.  
Gilson Engine Co., Guelph, Ont.

## MARINE FITTINGS

Northern Electric Co., Ltd., Montreal.

## MOWERS

Cockshutt Plow Co., Brantford, Ont.  
International Harvester Co., of Can., Ltd., Hamilton, Ont.  
Massey-Harris Co., Toronto.  
The Frost & Wood Co., Ltd., Smiths Falls, Ont.

## MILKING MACHINES

R. A. Lister Co. (Canada), Ltd., Toronto  
The Macartney Milking Machine Co., Ltd., Ottawa, Ont.

## MILLING CUTTERS

Butterfield & Co., Inc., Rock Island, Q.

## NUT LOCKS

Robinson Co., Ltd., Ed. A., Montreal.  
Spedoline Refining & Mfg. Co., Ltd., Montreal.

## OILS

Imperial Oil Co., Toronto.  
Spedoline Refining & Mfg. Co., Montreal.

## PISTON RINGS

WedgeRite Piston Ring Co., Ltd., Montreal.

## PLOWS

Cockshutt Plow Co., Brantford, Ont.  
John Deere Mfg. Co., Welland, Ont.  
The Frost & Wood Co., Ltd., Smiths Falls, Ont.  
International Harvester Co., of Can., Ltd., Hamilton, Ont.

## POLICE AND FIRE ALARM EQUIPMENT

Northern Electric Co., Ltd., Montreal.

## POWER AND LIGHT EQUIPMENT

Northern Electric Co., Ltd., Montreal.

## POWER MACHINERY

Can. Fairbanks-Morse Co., Ltd., Montreal.  
John Deere Mfg. Co., Welland, Ont.  
Massey-Harris Co., Toronto.  
International Harvester Co., of Can., Ltd., Hamilton, Ont.  
Gilson Engine Co., Guelph, Ont.  
Renfrew Mchy. Co., Renfrew, Ont.

## POWER SWITCHBOARDS

Northern Electric Co., Ltd., Montreal.

## POTATO MACHINERY

John Deere Mfg. Co., Welland, Ont.  
Cockshutt Plow Co., Brantford, Ont.  
Can. Potato Mchy. Co., Galt, Ont.

## PULVERIZERS

Cockshutt Plow Co., Brantford, Ont.  
International Harvester Co., of Can., Ltd., Hamilton, Ont.

## PULPERS

Cockshutt Plow Co., Brantford, Ont.

## RAKES

International Harvester Co., of Can., Ltd., Hamilton, Ont.  
The Frost & Wood Co., Ltd., Smiths Falls, Ont.

## REAPERS

International Harvester Co., of Can., Ltd., Hamilton, Ont.  
The Frost & Wood Co., Ltd., Smiths Falls, Ont.

## REAMERS

Butterfield & Co., Inc., Rock Island, Q.

## ROLLERS

Cockshutt Plow Co., Brantford, Ont.  
Massey-Harris Co., Toronto.  
Hyatt Roller Bearing Co., Chicago.

## ROLLER BEARINGS

Hyatt Roller Bearing Co., Chicago.

## SAW MILL OUTFITS

Massey-Harris Co., Toronto.

## SCUFFLERS

Cockshutt Plow Co., Brantford, Ont.  
International Harvester Co., of Can., Ltd., Hamilton, Ont.  
John Deere Mfg. Co., Welland, Ont.

## SEEDERS

Massey-Harris Co., Toronto.

## SCALES

Renfrew Mchy. Co., Renfrew, Ont.  
Can. Fairbanks-Morse Co., Montreal.

## SCREW PLATES

Butterfield & Co., Inc., Rock Island, Q.

## STABLE EQUIPMENT

Beatty Bros., Ltd., Fergus, Ont.

## SILOS

Gilson Mfg. Co., Guelph, Ont.

## SLEIGHS

Cockshutt Plow Co., Brantford, Ont.  
International Harvester Co., of Can., Ltd., Hamilton, Ont.

## SILO FILLERS

Gilson Mfg. Co., Guelph, Ont.  
International Harvester Co., of Can., Ltd., Hamilton, Ont.

## SOCKET WRENCHES

R. F. Sedgley, Inc., Philadelphia, Pa.

## SPREADERS, MANURE

Cockshutt Plow Co., Brantford, Ont.  
John Deere Mfg. Co., Welland, Ont.  
International Harvester Co., of Can., Ltd., Hamilton, Ont.

## SPARK PLUGS

Massey-Harris Co., Toronto.  
Gilson Mfg. Co., Guelph, Ont.  
Machine & Stamping Co., Toronto.  
Champion Spark Plug Co., Windsor, O.  
Apollo Plug Mfg. Co., Birmingham, Eng.  
Fyrac Mfg. Co., Rochfort, Ill.  
Lions Ignition Co., New York.

## SPARK PLUG CLEANERS

Champion Spark Plug Co., Windsor, O.

## TELEPHONE APPARATUS

Northern Electric Co., Ltd., Montreal.

## TRACTORS

R. A. Lister Co. (Canada), Ltd., Toronto  
Can. Allis-Chalmers, Ltd., Toronto.  
Chase Tractors Corp., Ltd., Toronto.  
Essex Tractor Co., Essex, Ont.  
Fiat, 501 Fifth Ave., New York.  
Gilson Mfg. Co., Guelph, Ont.  
International Harvester Co., of Can., Ltd., Hamilton, Ont.  
J. I. Case Threshing Machine Co., Inc., Racine, Wis.  
Massey-Harris Co., Toronto.  
Monarch Tractors Ltd., Brantford, Ont.  
The Gray Tractor Co. of Canada, Ltd., Winnipeg.

Renfrew Mchy. Co., Renfrew, Ont.  
The Turner Mfg. Co., Port Washington, Wis.

## TRACTOR PLOWS

Cockshutt Plow Co., Brantford, Ont.  
International Harvester Co., of Can., Ltd., Hamilton, Ont.  
John Deere Mfg. Co., Welland, Ont.  
Massey-Harris Co., Toronto.

## THRESHERS

Can. Fairbanks-Morse Co., Ltd., Montreal.  
International Harvester Co., of Can., Ltd., Hamilton, Ont.

J. I. Case Threshing Machine Co., Inc., Racine, Wis.  
R. A. Lister Co. (Canada), Ltd., Toronto  
Gilson Mfg. Co., Guelph, Ont.

## THREAD CUTTING TAPS

Butterfield & Co., Inc., Rock Island, Q.

## TWIST DRILLS

Butterfield & Co., Inc., Rock Island, Q.

## TRUCKS

Beaver Truck Builders, Ltd., Hamilton  
Eastern Canada Motor Truck Co., Ltd., Hull, P.Q.  
International Harvester Co., of Can., Ltd., Hamilton, Ont.

## WHEELBARROWS

Cockshutt Plow Co., Brantford, Ont.  
Massey-Harris Co., Toronto.

## WAGONS

Cockshutt Plow Co., Brantford, Ont.  
International Harvester Co., of Can., Ltd., Hamilton, Ont.  
Massey-Harris Co., Toronto.

## WATER BOWLS

Beatty Bros., Ltd., Fergus, Ont.

## WATER SYSTEMS

Westco Pump Limited, Toronto.

## WEEDERS

Cockshutt Plow Co., Brantford, Ont.

## WIRES AND CABLES

Northern Electric Co., Ltd., Montreal.



## Tools that Retain their Keen Edges after Long Usage

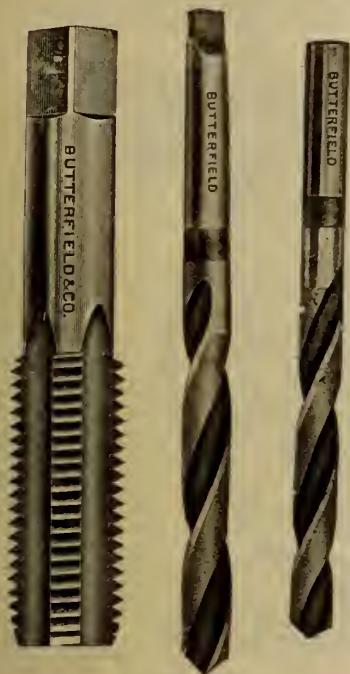

Here are tools that reduce repair expense to a minimum. They stay on the job keen-cutting and accurate every day of their long life.

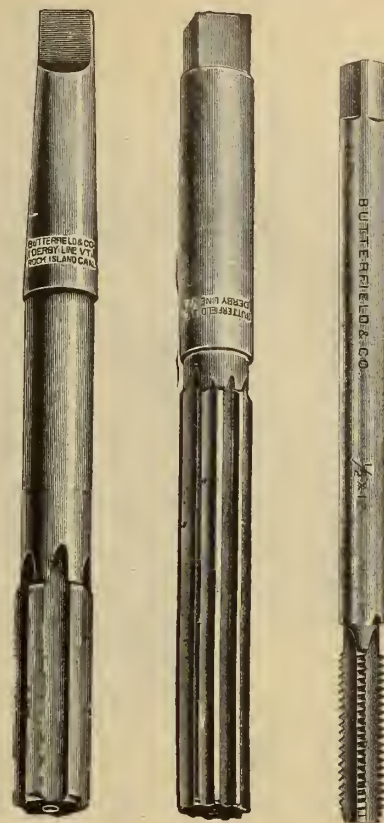

# Butterfield

## Drills, Taps, Dies,

## Reamers

and MILLING CUTTERS

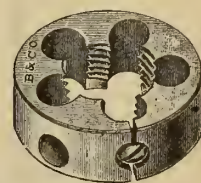
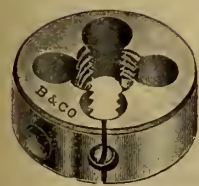

See that the name "Butterfield" is on the tools you buy. It is your guarantee of highest quality. Send for our catalogue.

### BUTTERFIELD & CO., ROCK ISLAND, P.Q.

TORONTO OFFICE: 220 King St. W.



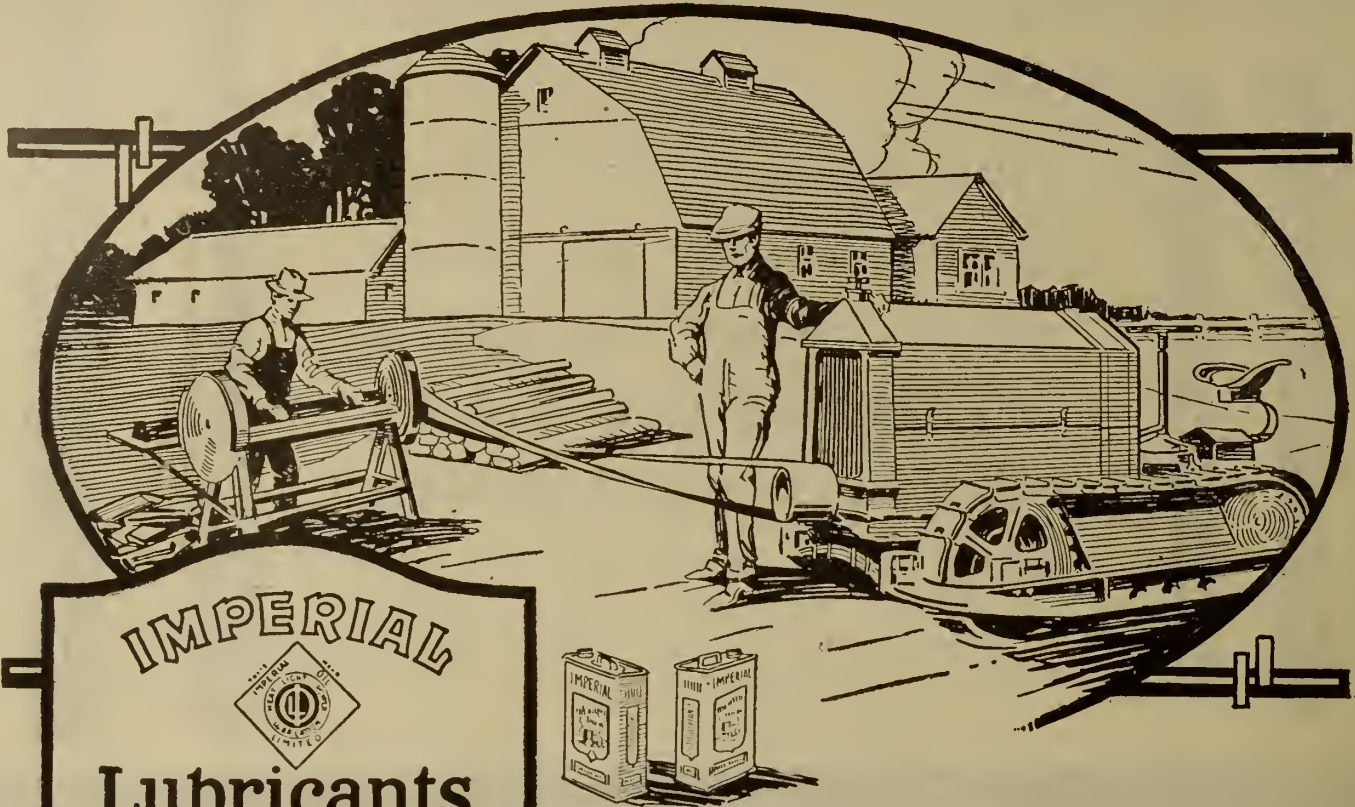

# IMPERIAL



## Lubricants

**IMPERIAL POLARINE AND  
IMPERIAL POLARINE HEAVY**  
For all gasoline-burning engines—auto-  
mobiles, tractors and trucks.

**IMPERIAL POLARINE A**  
For all motors requiring an unusually  
heavy oil.

**IMPERIAL POLARINE KEROSENE  
TRACTOR OIL AND  
IMPERIAL POLARINE KEROSENE  
TRACTOR OIL EXTRA HEAVY**

For kerosene-burning stationary engines  
and tractors.

**IMPERIAL PRAIRIE  
HARVESTER OIL**  
A heavy-bodied oil for open bearings of  
threshers, binders and separators.

**IMPERIAL ELDORADO  
CASTOR MACHINE OIL**  
A thick oil for worn and loose bearings.

**IMPERIAL CAPITOL  
CYLINDER OIL**  
For steam cylinder lubrication—tractors  
and stationary engines.

**IMPERIAL STANDARD  
GAS ENGINE OIL**  
For stationary and portable engines using  
either kerosene or gasoline.

**IMPERIAL THRESHER HARD OIL**  
For grease cup lubrication of bearings.  
A clean, solidified oil.

Imperial Farm Lubricants are for sale in  
 $\frac{1}{2}$ , 1 and 4 gallon sealed cans, half-barrels  
and barrels.

## How Many Tractors in Your District?

**D**O you know the number of tractors in your district? Do you know the number of automobiles, stationary engines, threshing outfits, farm lighting plants and other types of machines which need lubricating oils?

The farmers of Canada use vast quantities of lubricating oils each year. They represent the biggest percentage of the lubricating oil business.

For years we have specialized on producing oils and greases suitable to their requirements. The complete line of Imperial farm lubricants, shown to the left, has been developed to get this business.

Imperial Farm Lubricants are advertised extensively. They are well and favorably known to farmers. You can get their business and hold it if you stock all sizes and all grades and go after the business.

# IMPERIAL OIL LIMITED

Power - Heat - Light - Lubrication  
Branches in all Cities





# Beaver Trucks

*"Built For Business"*

**Built in Canada's Largest  
Exclusive Truck Factory**

**UNQUESTIONABLY  
"CANADA'S LOWEST HAULING COST"**

Some open territory still available—Catalogues and further information furnished responsible dealers upon request.

**Beaver Truck Builders, Limited**  
HAMILTON, ONTARIO



# Apollo

## SPARKING PLUGS

—are sure and satisfactory sellers!

You're on a good thing when you handle APOLLO PLUGS—they represent the highest standard of BRITISH plug manufacture, are fully tested to ensure maximum efficiency and are guaranteed to give complete satisfaction.

With the APOLLO range of plugs you can promptly meet every plug request—there are models for every type of Car, Motor Truck and Tractor engine—and every plug carries a GOOD PROFIT for YOU.

Super Mica Plug, is specially designed for high-speed, high-compression engines. It is unaffected by excessive heat and of exceptional durability—a plug that gives a quick start and adds power to the engine. Retails in the U.K. at ..... **6/-**

Porcelain Plug is specially designed for the FORD engine. It has Solid Brass body, 1/2-in. gas thread, is clean to handle, will not rust, fits the special Ford spanner, is insulated with finest porcelain and is detachable for cleaning. Retails in the U.K. at ..... **5/-**

Get on to the APOLLO PLUG proposition and you'll do big business in selling plugs. We can give prompt shipment of all models and supply you with posters, showcards and advertising literature. Write us for trade terms and full particulars of our models.

**APOLLO PLUG MFG. CO.**  
Moseley Street                      Birmingham, England

Codes: A.B.C. 4th Western Union

Plugs for                      all engines



APOLLO No. 1. Super Mica Plug

APOLLO Special



Overtime Tractor Plug



APOLLO L.C.B. Special FORD Plug



CANADIAN  
**MOTOR, TRACTOR AND IMPLEMENT**  
**TRADE JOURNAL**

Published Monthly by THE MACLEAN PUBLISHING COMPANY, LIMITED, TORONTO

MONTREAL, Southam Bldg.

WINNIPEG, 1103 Union Trust Bldg.  
 NEW YORK, 1133 Broadway.

VANCOUVER, 314 Carter-Cotton Bldg., 198 Hastings St. W.  
 BOSTON, 734 Old South Bldg. CHICAGO, 405-6 Transportation Bldg.

LONDON, ENG., 88 Fleet St., E.C. 4

VOL. II, No. 6

TORONTO, JUNE, 1920

Subscription Price  
 \$2.00 Per Year

*Apollo*

**SPARKING PLUGS**

—are sure and satisfactory sellers!

You're on a good thing when you handle APOLLO PLUGS—they represent the highest standard of British plug manufacture, are fully tested to ensure maximum efficiency and are guaranteed to give complete satisfaction.

With the APOLLO range of plugs you can promptly meet every plug request—there are models for every type of Car, Motor Truck and Tractor engine—and every plug carries a GOOD PROFIT for YOU.

Super Mica Plug, is specially designed for high-speed, high-compression engines. It is unaffected by excessive heat and of exceptional durability—a plug that gives a quick start and adds power to the engine. Retails in the U.K. at ..... **6/-**

Porcelain Plug is specially designed for the FORD engine. It has Solid Brass body, 1/2-in. gas thread, is clean to handle, will not rust, fits the special Ford spanner, is insulated with finest porcelain and is detachable for cleaning. Retails in the U.K. at ..... **5/-**

Get on to the APILLO PLUG proposition and you'll do big business in selling plugs. We can give prompt shipment of all models and supply you with posters, showcards and advertising literature. Write us for trade terms and full particulars of our models.

**APOLLO PLUG MFG. CO.**  
 Moseley Street Birmingham, England

Codes: A.B.C. 4th Western Union

Plugs for all engines



APOLLO  
 No. 1.  
 Super  
 Mica  
 Plug

APOLLO  
 Special



Overtime  
 Tractor  
 Plug



APOLLO  
 L.C.B.  
 Special  
 FORD  
 Plug





## The Secret of its Permanence is in the Wedge

Many piston rings hermetically seal the combustion chamber—for a few days, a few weeks, or a few months. WedgeRite Piston Rings seal permanently. Of course there is a final limit to the efficient performance of any product, but WedgeRites are distinctly in a class of their own by lasting longer than any other rings made.

This is due to the application of the wedge principle, which automatically takes up wear and preserves an even pressure on all sides of the cylinder wall.

*Order through your favourite jobber*

**Wedge Rite**  
PISTON RING  
**COMPANY**  
LIMITED

92 Notre Dame St. E., Montreal



THE  
WEDGE



- CROSS SECTION OF RING**
- 1—Section pressing outward and upward.
  - 2—Spring section of ring.
  - 3—Lower outward and downward section.

**ILLUSTRATING THE WEDGE PRINCIPLE**

The wedge principle employed in the making of WedgeRite Piston Rings is shown in the accompanying drawing. Its superiority, measured by its ability to expand in WIDTH as well as in diameter, means utmost satisfaction. The repairman who uses WedgeRite Rings is one who can be trusted. By using the Best Piston Ring he shows a real desire to give a better repair service.



# LIKE BRINGING OLD FRIENDS TOGETHER

*The Lister Line is Famous for Reliability*

THE name Lister is so familiar to the farmers of Canada as a synonym of the well-known British quality and dependability that your customer is half-sold before you talk to him.

## MELOTTE Cream Separator

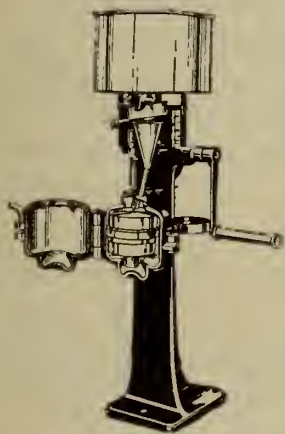

The separator with the self-balancing bowl, the only ball-bearing bowl on the market. This is the original Melotte, sold in Canada only by R. A. Lister Co. (Canada) Limited—the machine that is world famous for close skimming, easy running and easy cleaning.

**ROUSING  
SELLERS  
WHEREVER  
SHOWN**

**THE NAME  
IS A GUARANTEE  
OF QUALITY**

## Lister PREMIER Cream Separator

A simple, easy-to-run, easy-to-clean, close-skimming machine abounding with convincing selling features—one of the famous machines that has built up the Lister reputation for dependability.

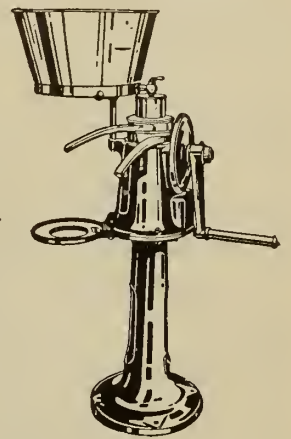

## Avery Tractor

Permits you to offer farmers the advantage of a size suited to his exact requirements—"a size for every farm"—saves waste due to over-size tractor on the farm—a big selling advantage.



## Lister Grinders

Will grind as fine and do more work than any other. Great capacity, easy running, never clogs. Handles all feeds with equal success.

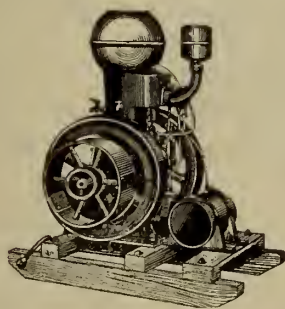

## LISTER ENGINE

2, 3, 5,  
7 and 9

Horse Power

## Lister Silo

A permanent, strongly built silo made of choice, well-seasoned lumber specially treated with preservative. Well designed.

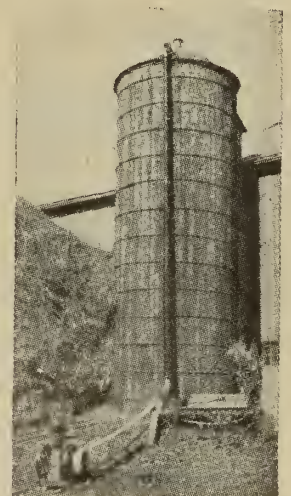

## The Lister Milker

Standard hopper cooled, throttle governed, automatic lubrication, high tension magneto; true British Quality throughout.

Won its reputation by giving practical results wherever used. Lister quality means long service. A system of regular inspection maintained by the Company. One of the greatest sellers in the farm machinery business.

*Write now for full particulars and attractive agency proposition*

**R. A. Lister & Company (Canada) Limited**

58-60 Stewart St., Toronto

Also at Wall St., Winnipeg



# HYLO SYLO

GILSON dealers are making thousands of dollars selling **HYLO SYLOS**  
**WHY NOT YOU?**

There's big money in the game!—We want you to get in on it! You've heard of the **HYLO-SYLO!** You know that it represents the highest achievement in silo construction.

**THE HYLO-SYLO** puts the Gilson Dealer in the strongest position of any silo agent.

The **HYLO-SYLO** price is as low as the lowest—and its value is as high as the highest.

It is made of either the well-known Long Leaf Yellow Pine or of Hardy Northern Grown Canadian lumber. The latter is treated in special preservatives. Both are exactly the same in construction.

With this combination you can lock the door on your competitors.

## Do It Now!

You can double your profits—we will show you how!

Write to-day.

You'll hear from us by return mail.

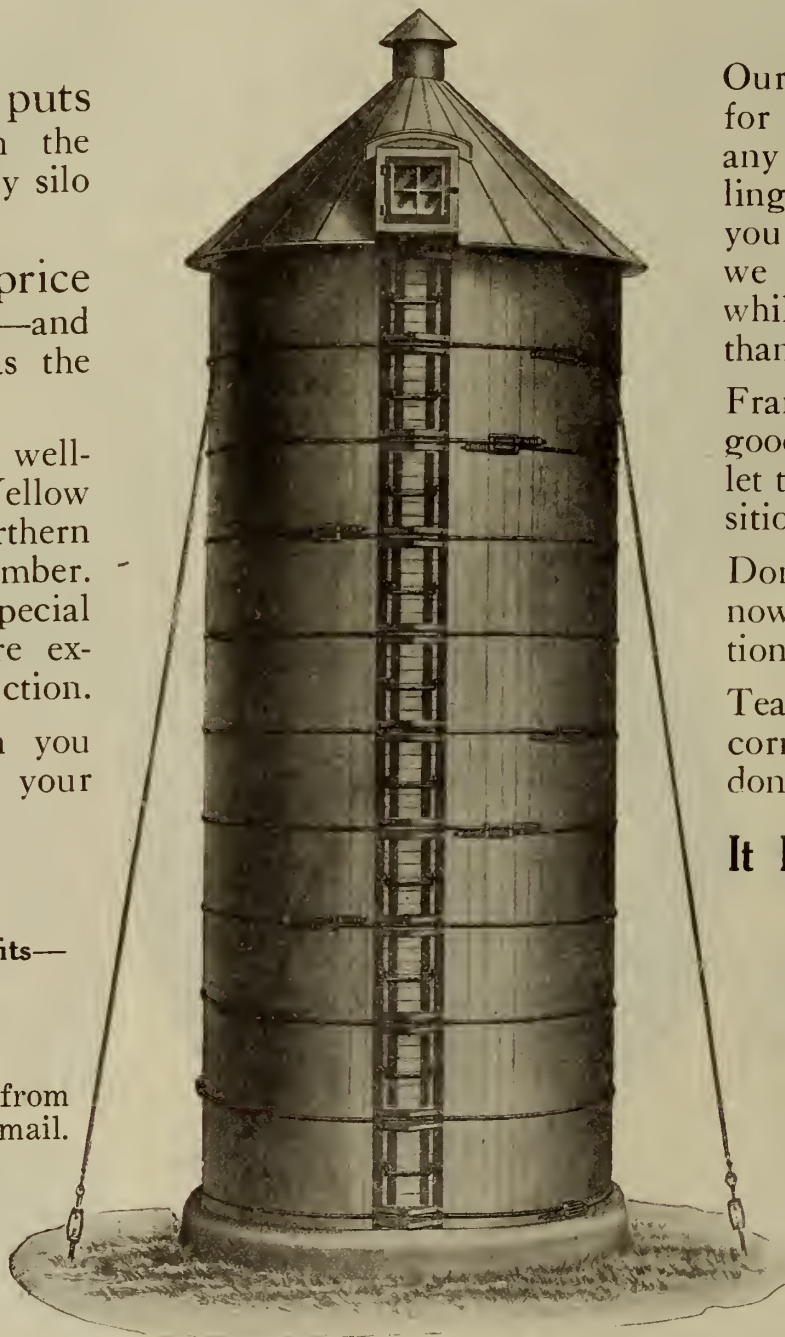

Our 1920 contract provides for bigger commissions than any other line you are handling. We have the goods—you have the connection—we will make it worth your while to push our silos harder than any other goods you sell.

Frankly now, doesn't it look good? You can't afford to let this money-making proposition go!

Don't put it off! Write us now for the agents' proposition.

Tear off, fill in and return the corner of this page. If you don't someone else will !!

## It Means Dollars to You!

*No Silo is complete without the wonderful Gilson Silo Filler.*

*It has the largest sale of any under the British flag.*

**BIG PROFITS—  
EASY SELLERS**

*Something worth adding to your lines.*

## GILSON MFG. CO.

LIMITED

Factory and Head Office, Dept. D  
 GUELPH, ONT.

Branch and Warehouse  
 355 Elgin Ave.  
 WINNIPEG, MAN.

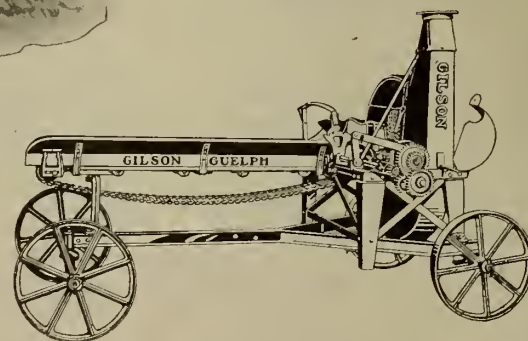

The Wonderful Gilson

**FILL IN AND RETURN AT ONCE!**  
 Without any obligation on my part you may send me your agent's proposition on: (Put an X opposite the product that interests you)

Silo  
 Silo Filler  
 Engine  
 Thresher  
 Manure Spreader  
 Tractor

Name .....  
 Post Office .....  
 R. R. No. ....  
 Remarks .....  
 Prov. ....

TEAR OFF HERE



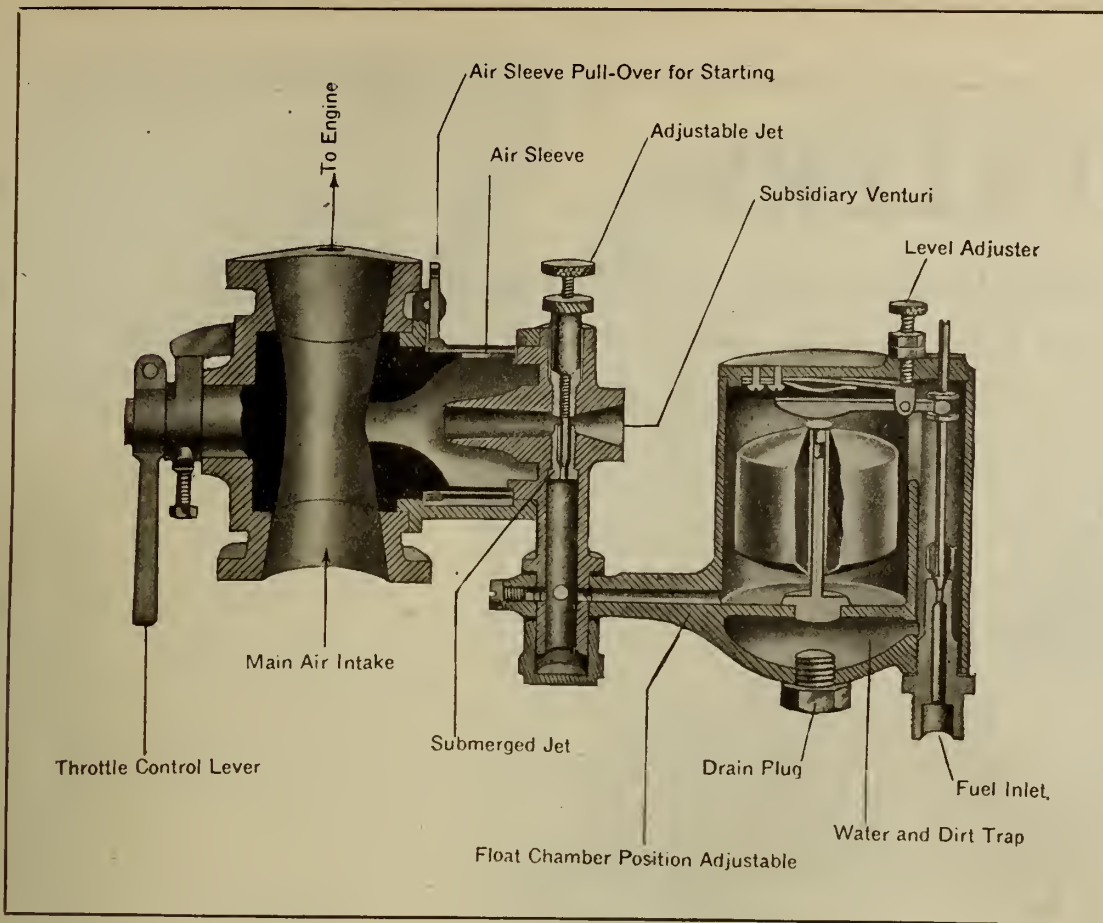

**Less Fuel—  
More Power**

*Read  
this unsolicited  
letter*

## COX "ATMOS" Carburetor

The Cox "Atmos" Carburetor introduces a new principle of carburation. Its main features are Simplicity and Economy.

It has but one moving part, the throttle—one jet, externally adjustable, and no spring controlled valves:

Its simplicity makes it easily adjustable and eliminates trouble from uneven mixtures.

WRITE FOR OUR DEALER PROPOSITION

*Sole Agents for Canada*

**British & Foreign Agencies  
LIMITED**

17 St. John Street, Montreal, Quebec

**VAN DER LINDE RUBBER COMPANY  
LIMITED**

142 WESTON ROAD  
TORONTO - CANADA

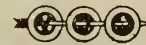

Montreal Office, 854 St. Catherine W.

May 27th. 1920.

British & Foreign Agencies Limited,  
808, Lewis Building,  
Montreal.

Dear Sirs:-

I feel that I must write you with regard to the wonderful performance of the Cox "Atmos" Carburetor, which you fitted to my Ford last January.

Last week I had occasion to make a business trip to Quebec City and on my arrival there was more than surprised to find that I had completed the trip from here at an average of thirty-three miles to the gallon.

On my return trip I took special care to note the mileage and found on my arrival in Montreal that I had done the 197 miles on five and a half gallons of gasoline. I might mention that I used the cheaper grade of gas.

With reference to the above, needless to say I am more than satisfied with my purchase of the carburetor.

Yours very truly,

(Sgd) Ernest E. Cherry

Montreal Manager,  
Van der Linde Rubber Company.

'Nuff Sed!



# DEALERS---

Get behind the JOHN DEERE-DAIN LOADER this Spring. Due to its reputation for Quality and Satisfactory Service. They are easy to sell.

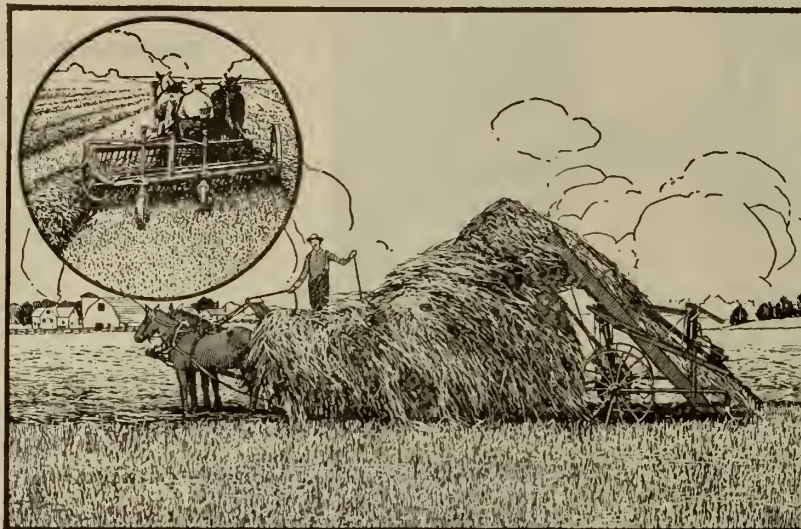

John Deere Advertising will be read by almost every farmer in Ontario

John Deere Advertising appears in these papers

Canadian Countryman  
Family Herald and Weekly Star

Farm and Dairy  
Farmers' Advocate  
Ottawa Farm Journal

Canadian Farm  
Farmers' Sun  
Farmers' Magazine  
Rural Canada

See that your prospects receive the special booklet "Better Hay—How to Make and Market it"

If you haven't a supply—write us

## SHOW THE FARMER HOW HE CAN save money and labor

by using this Loader. Point out these special features to him and the sale is made.

The John Deere-Dain Loader is a great labor-saver. One man can handle it, thus saving the wages of another man. It is the easiest running and most popular of the rake bar type.

The rear wheels caster—there is no dragging around corners. It is of light draft, roller bearings being used on all main journals.

Its principal working parts are hammock mounted. They swing freely without binding or strain.

Rakes are operated at the right speed to require the least power. The strokes of the rake overlap and thus rake clean. A very desirable feature.

Hay is gathered from the swath the full width of the machine. The change to windrow work is instantly made.

The automatic, adjustable throat opening prevents choking. Hay is delivered to the middle of the load. Elevator adjusts automatically to light and heavy hay.

Coupling is made to high or low wagons without any change.

It is strong, light and durable. It is the original rake bar loader and built with the usual "John Deere" standard of quality and careful workmanship.

If you are not already handling this Loader, write us at once.

John Deere Implements are sold only by dealers  
THE DEALER WHO SELLS JOHN DEERE IMPLEMENTS IS INDEPENDENT

John Deere Manufacturing Company, Limited, WELLAND ONTARIO



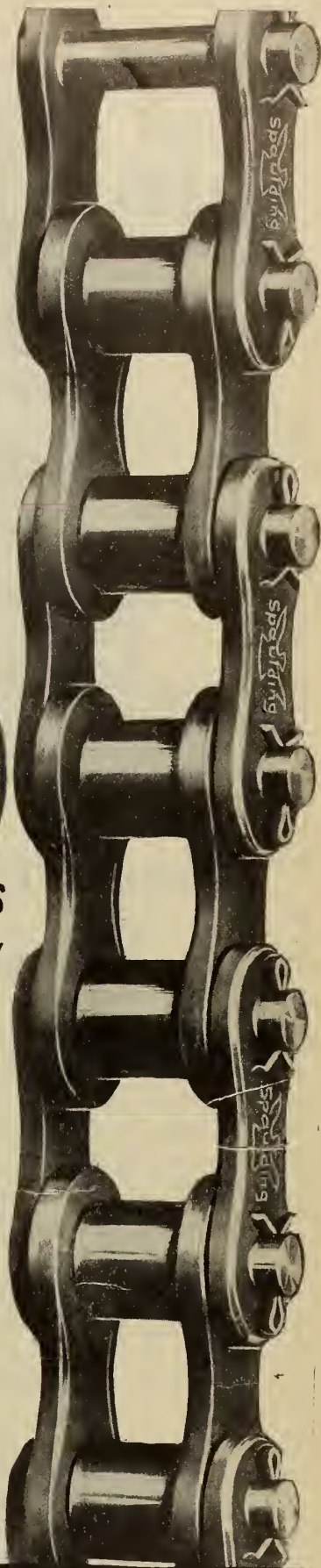

*The steel is tempered by a new process giving greater tensile strength— — —*

**E**VERY part of a Spaulding unit, both chain and sprockets, is tempered by a new heat treating process which makes Spaulding construction unequalled for **strength** and **durability**.

A Spaulding roller when submitted to the vise test illustrated below, will crush almost flat before it breaks, yet it has a hard, long wearing surface.

In the cross section shown under the magnifying glass you will see the case hardened outer wearing surface which graduates into a soft, pliable centre. This temper is produced by the new heat treating process and is the reason for the remarkable **endurance** of Spaulding rollers and bushings. It is an exclusive Spaulding feature.

In the field and on the road, this **surplus** strength insures freedom from broken rollers and bushings, longer life to the driving chain and eliminates loss of time due to broken chain and sprockets.

Our booklet on the chain drive is instructive and makes an invaluable reference guide. We will gladly send you a copy upon request.

SPAULDING CHAIN CORPORATION  
Fenton J. Spaulding, President  
Bloomfield, N.J.

**Spaulding**  
**ROLLER CHAIN**  
**& SPROCKETS**

Placed in a vise, a Spaulding roller withstands an unusual amount of pressure, bending almost flat before it finally cracks. This illustrates the efficacy of the Spaulding case hardening and heat treating processes.

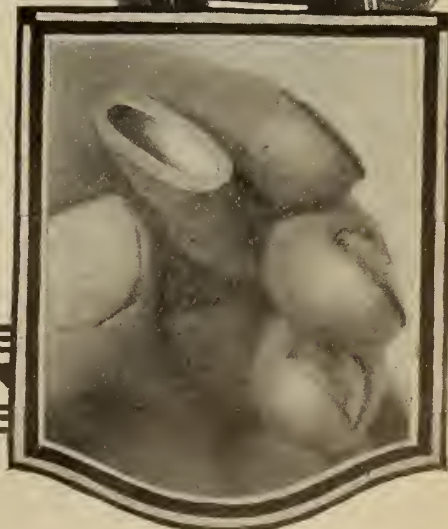
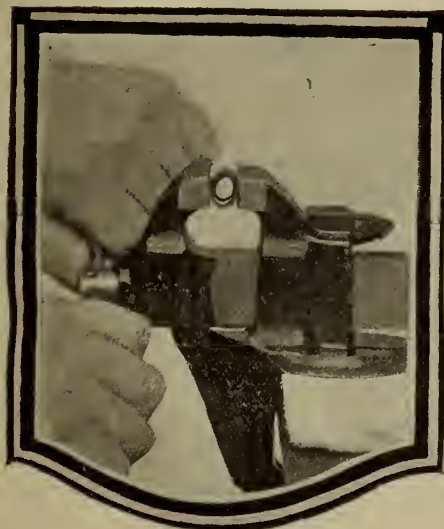

Spaulding roller after applying the vise test. Bent almost flat, but not broken!



40-Light-Plant

\$495

F.O.B. TORONTO

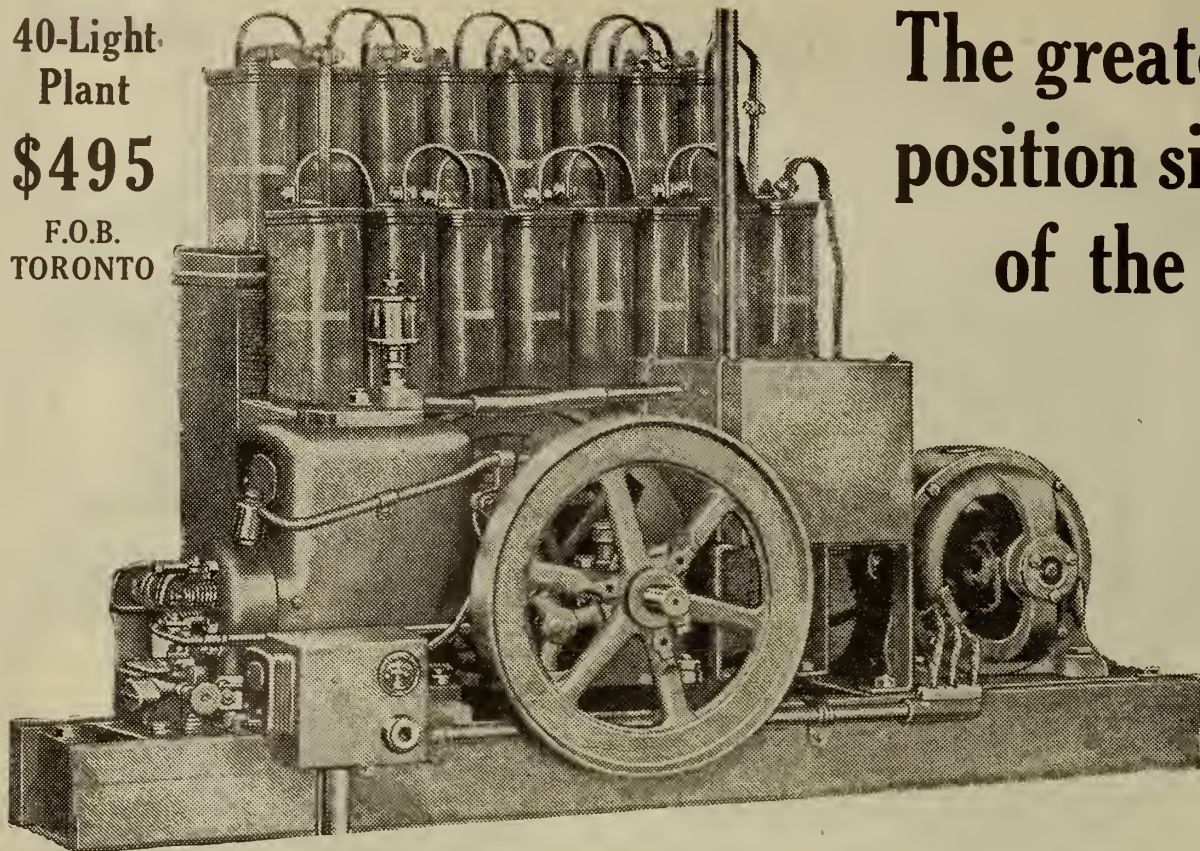

The greatest selling proposition since the advent of the automobile

# Become a Fairbanks-Morse Power & Light Plant Agent

Fairbanks-Morse Power and Light Plants present wonderful sales possibilities in your district. Their dependability, economy and simplicity of operation are appreciated by farmers everywhere who realize the many advantages of electricity, running water and convenient labor-saving power in the country.

The low price, combined with Fairbanks-Morse quality, is only possible in a Canadian-built plant.

The same features of service and super-quality that caused over a quarter of a million farmers to buy "Z" Type Engines, are embodied in the "F" Plant. Our agents have the whole-hearted support and cooperation of our organization.

Right now is the best time to mail this coupon

Our Dominion-wide advertising campaign has interested thousands of Canadian farmers in the "F" Plant. Fairbanks-Morse quality is so well known that "F" Plants are easily sold.



You are offered the opportunities and possibilities that automobile agents had years ago. Don't miss this chance.

Send the coupon now to our nearest branch and let us show you how big this opportunity really is.

Made in Toronto, Canada, and guaranteed by

## The Canadian Fairbanks-Morse Co., Limited

HALIFAX ST. JOHN QUEBEC MONTREAL OTTAWA TORONTO HAMILTON ST. CATHARINES WINDSOR WINNIPEG REGINA SASKATOON CALGARY VICTORIA VANCOUVER

DEALER'S COUPON  
Mail this coupon with your letterhead to our nearest branch for full particulars of Fairbanks-Morse "F" Power and Light Plant Agency.  
Name.....  
Address.....

MT



# CANADIAN MOTOR, TRACTOR AND IMPLEMENT TRADE JOURNAL

Volume 2

TORONTO, JUNE 5, 1920

Number 6

## The Tractor is the Great Need of the West

*“Out where the handclasp’s a little stronger,  
Out where a smile dwells a little longer—  
That’s where the West begins.”*

*Where there’s more of singing and less of sighing,  
Where there’s more of giving and less of buying,  
And a man makes friends without half trying—  
That’s where the West begins.”*

WE read of the days when the West was inhabited by traders, ranchers, and the red-skin; we hear the old timers talk about trekking across the prairies in an early day in an ox cart; we hear them tell how they started in and broke up a few acres each year until they had carved a farm out of the wilderness, and in looking back we marvel at the progress that has been made. The three Western Prairie Provinces now produce a large portion of the world’s food supply. We have only to look at the statistics of our annual crop yields to realize how important a part the West plays in food production, yet when we look ahead for an equal space of time we can scarcely picture what this broad land will be like.

### THE POSSIBILITIES HAVE ONLY BEEN TOUCHED.

We have been farming extensively, it is true, and have just reason to be proud of our record of production, our growth and wealth, but mile after mile of fertile land still lays in its’ natural state. One has but to travel from Winnipeg to the edge of the Rockies to realize this fact. The never ending stretch of country seems to create a feeling hard to describe—a feeling of pride, yet a feeling of shame—pride in our past achievements; shame to think we are so slow in opening up our vast resources. What we need is cultivation of our idle lands, and better and more intensive cultivation of our lands already under the plow. How can this best be done? There is but one answer, and that answer is “The Tractor.” It would take years to breed stock enough to accomplish the same end, and we would need thousands more of population.

I say again that the best solution of the problem at present is the tractor. Why?

Our labor situation is none too good. Men for farm work are hard to get, and the majority of them work on the principle of doing as little as they can for the highest wage obtainable. I am reminded of an old conundrum—“Who prays for rain more than the farmer?” Answer—“The hired man.” The tractor is helping to solve the labor situation. It is keeping the boys home on the farm by making farming conditions better for them, thus they are more content.

The present price of feed, both hay and grain, makes horse power an expensive way to farm and the farmer here in the West is reducing his operating costs materially by using power. I do not intend to convey the impression that a farmer should sell off all the horses he possesses and farm only with tractors. There is still use for the horse, but the

By W. A. PRUGH

number of horses can be greatly reduced and the annual feed bill is much smaller as a consequence.

Power is needed in some cases especially. In districts where the soil is extremely heavy it is almost impossible to break the sod with horses. The writer has seen six on a single fourteen inch plow. It is good land, too. It raises fine crops, but it takes “Power,” and “Power” is what the tractor can develop, and thus fill the needs of the situation.

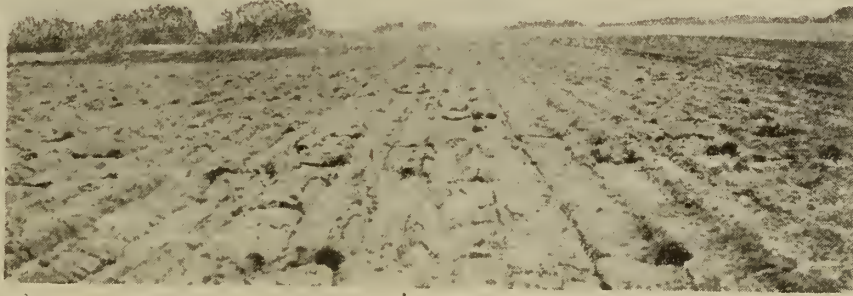

The tractor quickly converts prairie sod into an improved farm.

Better farming can be done with tractors. That extra inch or two deeper in the ploughing often makes a big difference in the yield. A good job of summer-fallowing done at the right time brings a return the next year.

ENDURANCE is another good factor in the tractor’s favor—the ability to deliver a constant steady stream of power to the draw bar, as strong and as dependable at the last hour of the day as at the first—counts for much in a season’s work. No slackening in speed as the day draws to a close. No waiting at the ends for a chance to breathe. No



A Gray Tractor doing its bit.

switching at flies or shaking of head. Just a steady pace and no call for rest. Our seasons are so short that when the land is in fit condition to be worked, much work must be done in a few days’ time. Then is when the tractor shines. The ability to put in overtime and “stay with the job” the few extra hours each day. It can rightly be called “The Iron Horse.”

It is mighty handy too, to have a power plant around the farm which can be used for belt work when needed. Crushing feed for the stock; filling the silo; sawing wood; and threshing in the fall. Some of our farmers have been slow to realize the assistance they can get from a tractor. They look upon them askance with doubtful glances, considering them as a burden and an expense, and talk about having money tied up in something from which they get use only at seasonable periods. Yet they do not hesitate to buy expensive high class motor cars. I have put it up to many in this light—to consider it as an investment, figuring a nominal interest charge on the capital invested therein. Even interest at eight per cent. on a thousand dollar tractor makes it’s annual cost small, and that much can be saved or made in a day or two oftentimes. A two thousand, twenty-five hundred, or three thousand dollar tractor on the same basis costs only one hundred and sixty, two hundred, or two hundred and forty per year to carry, in addition to the upkeep and a moderate charge for depreciation. How easy it is to make that extra hundred or two by having proper equipment to do work on time and in season. A certain man told me—“I not only made a good return on my investment, but I could charge off my books the entire cost of my tractor and still be money ahead. It paid for itself the first season.”

THESE are great days. It is a privilege to be part and parcel of the great movement to develop our vast natural resources. The joy of accomplishing something and helping the world at large—should appeal to each one of us. The great West is calling. Thousands are answering. The Door of Opportunity is open. We must keep pace with the world’s rapid stride. Men no longer need start out with two bare hands as did our forefathers. We have to assist us the years of development in modern machinery and engineering. We have the power lift plow and the power lift seed drill. We have the binder, automatic stookers and the cheap loader. We have the threshing machine with self-feeder and blower,—and we have the tractor—a power plant able to operate all these successfully and economically.

*Where the fields are broader and there’s  
work to do*

*For the farmer, the horse, and the tractor  
too—*

*Where every one’s happy when the day is  
through—*

*That’s where the West begins.*



# Points on Conducting a Successful Garage

A Proper System of Cost Accounting, Stock Arrangement, Appearance and Cleanliness Essential

By CECIL DIXON

**I**F the modern garage man would be successful he must adopt modern and up-to-date methods of conducting his business.

There is every evidence that the garage business will produce much more money in the future than it has ever done in the past, and the man who will make most and last longest will be he who runs his business in the approved, up-to-date manner.

Let me mention a few of the essential points which must receive the closest attention.

Go across the street some day and take a look at your place of business—see if it needs painting or washing—and you will likely decide on giving it a new suit of summer clothes. If the walls and windows are dirty, lose no time in cleaning them. Do not allow waste material of any kind to accumulate in or around the front of your garage. Make your place look inviting and restful.

A large number of garage men have omitted to put up a sign of any kind. If you have a sign at present, perhaps it needs dressing up and re-painting. Perhaps you could arrange to have an illuminated sign so that it could be lighted at night and seen from a distance. You should try and have the word "Garage" conspicuous—as well as your name—and then live up to the word by giving genuine repair service on cars, trucks, tires and storage batteries, and carrying a stock of automobile accessories and tires, or any other things any regular or passing customer or car owner may happen to find he needs.

Try and use the windows to display some of your stock of auto accessories. Try and keep your desk in the office and any counters or shelves around the place so that they give the impression of neatness and order and system. If you cannot drive yourself to dress up the window or show cases, you will find many of the jobber's salesmen quite willing and capable of dressing the window if you provide a few materials and help him. He will appreciate the opportunity of helping you.

**T**HE garage should be kept clean from end to end. The floor will require cleaning every week, and more often if necessary. The repairman or workman should even try and arrange to have their overalls washed once or twice a week—particularly if they are getting in and out your customers' cars. There should be order in the repair shop. Tools should be kept in their places.

Every garage man should have a system of costs and accounting that will tell him where he is making or losing money, so that he can check his transactions and increase in his profits where possible. He should have a stock system that prevents his money being tied up in obsolete stock and which will also prevent his being without merchandise for which his customers are

anxious to exchange their money. Every proprietor should find out how much it costs to do everything, and how much he must charge to make a profit. He will refuse to sell goods on which he cannot make a profit. He will never cut prices. He will never give away goods. Why give them away on the sale of a new car? When a man buys a car he buys a car and nothing else. Accessories are extras and certainly should be paid for as such. It is just as easy when you have got the backbone to get your price for the accessories as it is to give them away.

Make your accessory business just as nearly cash as it is possible for you to do. Business can be done cheaper on a cash basis. The dealer can afford to lose some business by insisting on cash. In the long run he actually is ahead since the lost business usually will amount to less than the amount which will be lost to bad accounts in doing a credit business.

It isn't the volume of business you do so much as it is the getting the pay for what you do sell.



Too much attention cannot be given to the arrangement of stockrooms in order to facilitate storage, display, filling orders and sales. If upon trial the existing arrangement does not prove to be the most advantageous and beneficial, changes should be made, provided, of course, such changes do not involve prohibitive expense. The man in charge of the stock should be a man capable of estimating the

advantages of arrangement, and, if he is not, then he should be replaced by someone who is.

**T**HE proprietor should devote most of his time to the managing end of his business, instead of working around in the shop and doing work for which he can hire help. He should make it his business to keep in personal touch with his customers and build valuable good-will and profitable business. By so doing he can see to it that his business is liked by the public, that his customers come back again, and leave their money with him.

You cannot succeed unless you become a real merchant; and you cannot become a genuine merchant unless you do some of the things which have made other merchants in other lines successful.

Some of the best people in town may be coming into your place of business. See to it that "my lady" does not have to raise her skirt to escape the filth or hold her nose to get away from bad odors or hold back from shaking hands with the proprietor because he has just been fixing something. How far would you get in a drug store business if the proprietor wore the same kind of clothes that some garagemen wear in their store or shop? How far would you get in the hardware business if your method of keeping books was the same that many garagemen use in keeping their business records? By all means occupy your right position as a good man of business in your own town.

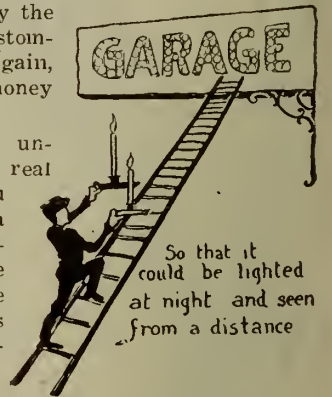

Is the Proprietor here?

Er—why yes, Madam Right here



See to it that "my lady" does not have to hold back from shaking hands with the proprietor, because he has just been "fixing" something.

## Haynes Expands

A sixty per cent. stock dividend—the largest in the history of the company—and a unanimous vote of approval for the erection of an immense body plant producing at least fifty automobile bodies a day, is a summary of the action taken recently at the annual meeting of the stockholders of The Haynes Automobile Company. Twenty-six stockholders, representing 22,700 shares of the 25,000 shares of Haynes stock, were present. The meeting was an enthusiastic one.

Work on the new body plant, the plans for which have already been completed, will start at once. It will be 845 feet long, 75 feet wide, and two stories in height. Fifty bodies a day will be its output. The construction of this new body factory will be of the most modern steel and concrete, and absolutely fire-proof.

At the board of directors meeting, C. H. Haynes, brother of Elwood Haynes and formerly head of the Haynes factory branch at San Francisco, California, was elected to the board of directors to fill the vacancy caused by the recent death of Stephen Tudor. The old staff of officers was re-elected for the following year with Elwood Haynes as president and C. C. Cartwright, vice-president.



# The Various Aspects of Tractor Service

By ARNOLD P. YERKES

SERVICE is a subject which we hear discussed a great deal these days. Not only are dealers taking more interest in service than was the case a few years ago, but customers are also paying more attention to this rather intangible thing which they expect to accompany any machine which they buy.

The automobile business has been largely responsible for the education of the public in the meaning and value of service, and now every intelligent man when he buys an expensive and somewhat complicated machine, such as the tractor, has learned to give the service question due consideration.

Implement dealers are far from agreed as to the amount and quality of the service to which their customers are entitled. Some dealers take the attitude that all they are in business for is to sell machines, and that any service which they require after once in the hands of the user should be paid for. Other dealers go to the opposite extreme and spend so much of their own time and that of their employees in keeping machines in working order that their profits are entirely wiped out and they actually do business at a loss.

It is certain that the optimum amount of service lies somewhere between these two extremes. It is a very short-sighted dealer who takes the attitude that he is not required to give any service whatever with the machines which he sells. He cannot hope to build up a very profitable business along this line, if, indeed, he can remain in business at all by following this policy.

An implement dealer should realize that he has a very distinct duty to perform in his community, and that he is not living up to his obligations if he does not perform it. His duty does not consist merely of buying machines at one price and selling them to the farmer at a higher price

—the farmer could do his own ordering at less expense if this were the entire function an implement dealer performed. It is this class of dealer who is largely responsible for the opinion held by many farmers that the dealer is an unnecessary middleman who adds to the cost of equipment without performing any real service.

THE dealer who is fulfilling his real duty is one who is capable of selecting first-class lines of machines which are suitable for the conditions in his neighborhood and whose business experience enables him to select from among the manufacturers those concerns which are prepared to give the proper kind of service. But this is by no means all he should do. The dealer who hopes to build up a solid business and one which will increase as years go by must be well posted on the farming possibilities and requirements in his community. He should foresee the need of new machines to meet changing conditions or to handle new crops which are being grown in his neighborhood. He has better opportunities to keep posted with regard to improvements and additions to farm equipment—he should always be ahead of the farmer in this respect. And after he has selected the best machines and placed them in stock he must be prepared to keep these machines in satisfactory operation on the farm. It is on this service proposition that the dealer can best justify his existence, and make it to the advantage of the farmer to buy from him rather than from a mail-order house or through co-operative organizations.

As already stated, this service should not be so extensive or so expensive as to absorb all the profits from his sales. His own business judgment should tell him how much service he can afford to give on the individual machines. It should also tell him what

class of service should be given without charge. Most farmers have a sense of fairness and do not expect a dealer to give them unlimited and unending service without charge. It is true that some are unreasonable on this point, and in handling these the dealer must be governed by his own judgment as to the amount to which they are justly entitled. The amount of business which he receives from a customer, the influence which the customer has on the other farmers in the community, etc., must, of course, receive consideration. It often pays to do something for a good customer which it would be unwise to do for some other customer whose business was not so valuable.

QUITE a good many repairs and adjustments are made necessary through abuse or inefficient operation at the hands of the operator. Ordinarily, service caused by ignorance or carelessness of the

best methods to follow in giving service on tractors. Each dealer must meet his own conditions and work out his own salvation along this line. It is absolutely necessary, however, that the dealer be thoroughly familiar with the care and operation of the tractor which he handles, or else have some good man in his employ who is competent in this direction. It is always best, however, for the dealer to study the tractor until he is absolutely familiar with its every part and function, even though he maintains a first-class expert who is expected to do the actual work of adjusting and repairing. Many dealers who sell only a few tractors each year will, of course, find it impractical to maintain such an expert, but as soon as the business reaches sufficient volume to justify it, it is certainly advisable to have a first-class repair man and the necessary equipment for handling all repairs for the machines which have been sold. A great many dealers who maintain such repair departments have been able to make them entirely self-supporting through the repair work which they do on other machines, and on repairs for their own machines which have been out several years and for which free service cannot be expected.

It is an obvious fact that the implement business is gradually drifting into the hands of fewer but larger dealers, the small and inefficient dealer dropping out while the efficient dealer is building up his business. It has been writer's observation that most cases where a dealer has built up a large implement business, with tractors as an important line, it has been accomplished largely through a high quality of service. Farmers are like other people—when they buy a machine which gives them satisfaction they tell their neighbors and recommend that they buy the same make. The dealer who keeps his tractors in working order and satisfied is receiving the

very best possible kind of advertising, and is bound to increase his business as a result of such service.

And right here it may be well to point out that the expense of keeping tractors in working order has an advertising value which should not be overlooked—it is not entirely an expense for which no return is received.

However, the best of service will not make a success of a poor tractor, and it is of the utmost importance that the dealer secure the very best machine possible. After all, the kind of service which the farmer most appreciates is that which he receives from the machine itself. He would much prefer to have a machine operate perfectly from the time it was bought, without having to call on the dealer to make adjustments or repairs, but next to this he appreciates prompt help when the machine breaks down or needs adjusting. The better the tractor which is handled, therefore, the less expense there will be for service, and the more satisfied customers, with the increase of business due to such satisfied users.

## Tractor Appliance Company

THE Tractor Appliance Co., of New Holstein, Wis., has been incorporated and is preparing to increase its sales campaign.

This company manufactures the Taco Governor and Siphon Air Washer and has now taken over the Quick-Stop and Calumet Tractor Hitches. The company announces the following appointments: P. L. Schneider is appointed in charge of the Minnesota territory with branch office at Minneapolis. J. L. Suter has taken charge of the eastern Missouri and southern Illinois territory. J. C. Keller has been appointed sales representative in South Dakota with headquarters at Aberdeen.



The Tractor Has Revolutionized Farming Methods

operator should be paid for, but this is not always practicable or at any rate advisable. Careful instruction of the owner or operator at the time the tractor is delivered will go a long way toward avoiding troubles of this kind. Neither the manufacturer nor dealer can eliminate this source of trouble without co-operation on the part of the farmer. Several manufacturers and quite a number of dealers have gone to the trouble and expense of putting on schools for the instruction of tractor operators in order to insure having the men receive proper instruction in the care and operation of the machines, with a view to reducing trouble calls from the causes mentioned. These have undoubtedly helped considerably, but it is impossible to reach all operators in this way.

The "ounce of prevention" works just as well in preventing trouble with tractors as it does in any other case, and there is no better way of avoiding troubles due to carelessness or ignorance of the operator than by taking time to give full and careful instruction at the time the machine is delivered.

It has been true in the past, and will doubtless be true in the future, that new machines require the greatest amount of attention and service after they are in the field. A few years ago binders required considerable service from experts to keep them operating satisfactorily, as a great many farmers were unfamiliar with their care. To-day service on binders is comparatively uncommon, as nearly every farmer can make his own adjustments or repairs or has a neighbor who can help him out. The tractor is still comparatively new, and more or less service will be needed on these machines for some years to come, but the amount will grow less as the number of tractors in use increases and the farmers become more familiar with their care.

No hard and fast rules can be laid down for the



# CANADIAN MOTOR, TRACTOR AND IMPLEMENT TRADE JOURNAL

Published on the fifth of each month by

The MacLean Publishing Co., Limited  
TORONTO, MONTREAL, WINNIPEG

JOHN BAYNE MACLEAN,  
President.

H. T. HUNTER,  
Vice-President.

H. V. TYRRELL, General Manager.

LONDON, ENG., THE MACLEAN COMPANY, OF GREAT  
BRITAIN, LTD., 88 FLEET STREET, E.C.

BRANCH OFFICES: Montreal, Southam Building, 128 Bleury  
Street; Winnipeg, 1103 Union Trust Building; Vancouver,  
314 Carter-Cotton Bldg., 198 Hastings St. W.; New York,  
Room 620, 1133 Broadway; Chicago, 405-6 Transportation  
Bldg.; Boston, 734 Old South Building.

SUBSCRIPTION PRICE—\$2.00 A YEAR.

OFFICE OF PUBLICATION—143-153 University Ave., Toronto.

Vol. II. TORONTO, June 5, 1920 No. 6

## The New Budget

WHEN Sir Henry Drayton launched his budget a little over two weeks ago, Canada was introduced to a more direct process of taxation than it had ever experienced.

The levying of one per cent. tax, in addition to the excise and customs duties, on all sales of manufacturers, wholesalers and retailers is a new departure. But the most outstanding feature of the budget, says "The Financial Post," is the manner in which the Government has conscripted manufacturers, wholesalers and retailers as tax collectors. The purchaser is to be furnished with a written invoice of any sale stating separately the amount of the tax when such tax is not included in the purchase price. This tax must not be included in the manufacturer's or wholesaler's cost on which profit is calculated. The tax is to be paid to the wholesaler or manufacturer by the purchaser and in turn remitted to the Government under a penalty provision not exceeding \$500.

The 7½ per cent. war tax on imported goods imposed in 1915 and 1919 has been wiped out. In the case of automobile imported from the U. S. the war tax of 7½ per cent. has been taken off and the tariff has been increased from 10 per cent. to 15 per cent. Under this new arrangement the imported car is in a slightly better position than it was previous to the budget. With the 15 per cent. tax now imposed on automobiles, plus 1 per cent. turnover tax, the total excise tax is 16 per cent. as against 17½ per cent. previous to the budget. Thus the imported car benefits by 1½ per cent.

The Canadian manufacturer of automobiles is not quite so well off. His protection has been reduced and he is compelled to absorb in his car's selling price, not only his own one per cent. and the 15 per cent. excise tax, but also the one per cent. charged against the various Canadian manufacturers making parts used in his car.

All cars taken out of storehouse (a showroom or garage is held to be a "storehouse" by the Department of Inland Revenue) come under the new excise.

It is noteworthy that the measure refers to automobiles as "passenger" cars, thus conceding a point which the trade has been contending for years, namely, that the automobile should no longer be referred to as a "pleasure" car but as a utilitarian necessity.

Altogether the automotive industry has fared better in the new taxes than was expected prior to the presentation of the budget.

It is too early to say what effect the excise will have on the automobile and power farming industry. In this connection M. T. I. communicated with a number of the large manufacturers and distributors, and in the next issue will be in a position to publish their views.

## What Would You Do?

IN the February issue of M.T.I. we published an editorial under the above caption. It told of a dealer who sold a power-lift sulky plow to a farmer, and, as is usual in such sales, supplied the extra two shares. The farmer came into his office a few days later and asked for two shares, claiming that they had not been included when the plow was de-

livered. Fearful of antagonizing the farmer, this dealer gave him the other two shares. We asked our readers what they thought of the dealer's action and what they would do under like circumstances. The following letter from an Albertan dealer was sent in to M.T.I., telling how he overcomes such a difficulty:

"We simply overcame this trouble several years ago by making a rule to take a signed receipt for every complete machine or implement delivered from our warehouse. We enclose one of these blanks, which we have for every machine we handle. We check the various parts onto the farmer's waggon



The Great Find.

with the purchaser or teamster, and, as a result, have no such dispute." The blank follows:

Received from J. M. R. & Co., One New Deere Sulky, as follows:

- 1 beam and bottom.
- 1 frame with seat, lever and axle.
- 1 land wheel, 98 and X119.
- 1 front wheel, 97x119.
- 1 rear wheel, 14100, G514 and G515.
- 1 pole.
- 1 neckyoke.
- 1 rolling coulter.
- 1 evener (state size).
- Extra bottom (state mark).
- Extra share (state mark).

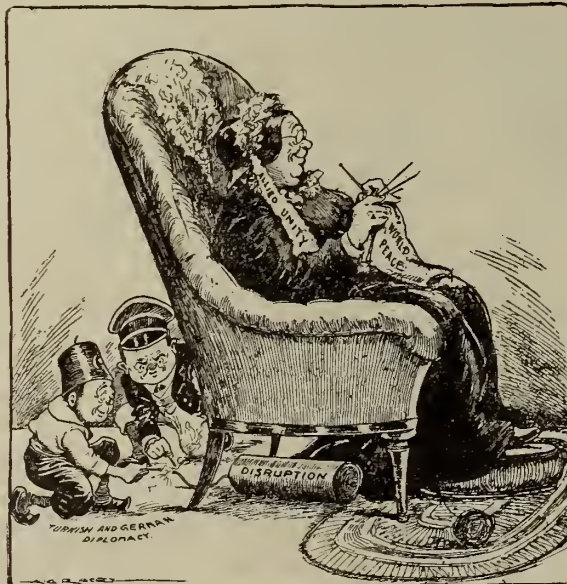

... "Two souls with but a single thought."  
—Racy in Montreal "Star."

## Make Your Service a Real Partner to Sales

POOR service negatives good salesmanship. And poor service does not mean merely poor workmanship in the repairshop. Good shop work without intelligent management is not good service. Good management implies selling of service. And *selling service, to be handled in the right way, must be a separate operation from performing service—the former is a salesman's job, the latter a technical man's.*

The automobile industry is rapidly approaching the day when cars—and later on, no doubt, trucks and tractors—will stand on a basis of general equality in their separate classes, as products. The dealer in one car will have equal opportunities for patronage with the dealer in another of like type, as far as the cars go. *Who, then, will have the advantage? The dealer with the better service—and this means not only better performed service, but better sold service.*

In a word, the selling of service must be recognized as a department of every business. The big dealer will have to train and equip a service sales force. The small dealer will have to develop a man or men in his service department capable of meeting people in a business way—men who will be service salesmen part of the time and service operators the rest of the time.

These service salesmen will have to develop ability not only to meet customers, diagnose car troubles of cars and discuss work to be done, but to pre-sell that work, to inform the customer beforehand, with the aid of a flat rate or some other estimating system, what the work will cost and get the customer's authorization to do that work. And behind the service salesmen will have to be service operators able to do the work, with profit to the dealer, within the price fixed, and able, as well, when occasion requires, to do quick, accurate work on rush jobs. And back of all these there will be required a clerical department equipped to handle promptly the "red tape"—and there should be no more of it than is necessary—of putting jobs through, charging them, billing them and getting payment on them.—Motor World.

## More About Trucks

DON'T forget to read the truck article on page eleven, by Donald R. Cowan. Mr. Cowan has devoted much of his time to an exhaustive study of trucks in relation to the farm and farm economics. The points he brings out in his article, especially the one dealing with selling the farmer the community truck, are of special significance.

There is no question about the farmer requiring trucks but it is important that the dealer should be able to determine what kind of truck is suitable for the requirements of a particular farmer. The dealer can only arrive at his conclusions after making a careful study of conditions, farmers' needs, truck capabilities, etc., etc. Hence the necessity of the dealer having a thorough and dependable knowledge of his truck. He must "know." Guessing and the "hit or miss" method has long gone by the board in power farming. The truck truly belongs to the power farming class. Farmers are said to be the greatest users of trucks; that being so the dealer in power farming should be the greatest seller of trucks.

There is a wonderful opportunity to-day for the dealer who jumps into the truck business, but he must be ready and able to appreciate transportation requirements.

## A New Motor Fuel

THOUSANDS of gallons of benzol, a by-product of coke, are now being used for motor fuel. While being much more combustible than gasoline, benzol has not as yet reached the highest stage of refinement, and present results are best when it is mixed in equal proportions with gasoline. Heat and cold also have a totally different upon it than upon gasoline. Ford chemical laboratories, however, are doing a great deal of experimenting and soon hope to be able to refine it so it can be used alone and under all conditions. Of course, its chief effectiveness comes from its high combustive power which is between twelve and fifteen per cent. greater than gasoline.



# Are You Selling Trucks—or Transportation

## Educate the Farmer to the Community Truck Idea

NOT long ago a salesman in a large departmental store was endeavoring to sell a top coat to a customer. When the customer had heard almost every argument in its favor, he simply stated that he required something which would be serviceable. If it could not be obtained cheaply, he was willing to pay a higher price. The salesman replied, "If I sell you a coat which is not all I represent, you will never be satisfied. You will tell your friends, and neither you nor your friends will ever patronize me again." He sold the top coat.

Exactly the same principle holds good in selling motor trucks to farmers.

### Selling Satisfaction

USUALLY the farmer is either an enthusiast or a "knocker." If his truck pleases him no person will convince him that he could have made a better purchase. He will tell his neighbors that he gets a greater mileage per gallon of gasoline in operating his truck than any other farmer in the community, and that he can ship his fruit, milk, or other produce to market more cheaply and in better condition by truck than by railway express. He proudly relates that he has spent "not more than \$5 for repairs, all season,—mostly for spark plugs and tire punctures." Under his influence, neighbours who are prospective truck purchasers will acquire a strong bias in favor of his make of truck.

*The enthusiastic farmer is the truck distributor's best agent and he works without salary or commission.*

But if the farmer is disappointed in his truck, he will tell his neighbors. Possibly he can blame only himself. As a rule, however, he will not assume the responsibility for his own failure. He will say that the truck was poorly constructed; the roads were too bad in his locality for successful truck operation, or the salesman sold him an unsuitable truck for his work.

The real reason for his disappointment may have been the lack of sufficient business to make the truck economical.

### Truck Must Justify Its Existence

THE great majority of farmers do not have a knowledge of book-keeping. They make no systematic allowance for fixed and maintenance charges against any of their farm equipment. When the farmer purchases a truck he underestimates the amount of those charges. He thinks more of the cost of gasoline, oil, and tires. He does not realize that his truck will depreciate and that after a time it will be necessary for him to buy a new truck.

In the long run, the truck must justify its existence on the individual farm by earning not only cost of operation, but also fixed and maintenance charges. These charges accumulate no matter whether the truck is in use or not. If they are to be met out of the earnings of the truck, the truck must be steadily employed, in most cases, over a large part of the year.

Fruit and vegetables can give a one-ton truck steady employment, especially if they have hot-houses. It enables them to market highly perishable products more rapidly and in better condition than any other conveyance. But the ordinary general farmer does not have a large quantity of perishable products to place on the market. Grain is non-perishable and the general farmer can team it to market at any time after harvest when the weather prevents him from doing other work on the farm. To try to sell a truck to the individual general farmer is usually a waste of time. While there are exceptions, the

By D. R. COWAN, M.A.

Investigator of Rural Motor Transportation for the Ontario Department of Agriculture

odds are against the successful use of the truck, if a sale is made to a general farmer.

### Selling Transportation

THE salesman should realize first and last that he is selling transportation.

Before he sets out to sell a truck in a rural community he should make sure that it will render a service. It must be more economical than the existing transportation facilities.

A survey of the general farming community is of paramount importance because the whole community may be able to furnish sufficient freight for a truck service while the farmers individually might not be able to own a truck on a paying basis at any time. Under these circumstances the truck salesman may have several alternatives.



THE LONG ARM OF THE FARMER.

Motor in Canada.

Many farmers need a motor truck, although they are unable to use it to capacity. In many cases, such farmers have gradually begun to haul to market a part or all of their neighbor's products. Occasionally, this practice has led to the establishment of a regular motor express route. These farmers have been enabled to purchase trucks because of the fact that the total volume of farm produce moving to market has made it economical to use the motor trucks. The farmer who is hauling farm produce for his neighbors is performing a useful function. The farmer-operator can usually offer transportation service at reasonable rates.

The truck salesman should investigate the possibilities for a trucking business in the rural community in order to be able to convince the farmer

needing a motor truck for part-time service that he may use a motor truck economically if he is an enterprising business man.

### The Community Truck

ANOTHER opportunity for the truck salesman may be found in collective ownership. There are hundreds of rural co-operative associations which exist for the purpose of marketing farm products and buying farm supplies more economically than through the ordinary middlemen. So far, however, only a few associations have attempted to reduce the cost of transportation. Since most of their produce is moved only a short distance to market, shipping point, or central market, and the truck is usually more economical for short hauls than the railway, many co-operative clubs would accomplish a great saving by owning and using a truck. Some clubs already exist for no other purpose than to reduce transportation and handling costs by using a direct motor service to market.

Near Unionville, in the Province of Ontario, there exists a co-operative association of fifteen farmers. Each farmer contributed an equal amount of capital to buy a motor truck. This truck is now used in hauling milk for a distance of about twenty-five miles from the farmers' gates direct to the receiving rooms of several dairies in Toronto. As compared with the railway express service, the truck makes it possible to market the milk in less time, with less danger of souring, and at a lower cost owing to the elimination of terminal handling. The saving accomplished by shipping the milk by truck instead of by train was sufficient to pay all operating costs, and to wipe out the investment in the first nine months of operation.

It is seldom that a co-operatively-owned truck can be used successively in hauling farm products only. Usually the nearest approach to it may be made in the milk-producing districts; but, in order to reach its maximum efficiency, even a dairy route must have return loads of supplementary freight, such as groceries, dry goods, and hardware for the members of the association, other farmers, and country merchants. It is important that such return freight should be obtained because it will usually bear a much higher rate than farm products and will frequently furnish the greater portion of the revenue.

### Study Transportation Needs

MANY farmers' associations or clubs would be ready to buy a truck if they were shown that it would be a profitable investment. When canvassing a rural community with this object in view the truck salesman should take into consideration the present transportation facilities, the condition of the roads, the amount of farm products moving to market in a steady stream, the amount of return freight obtainable, the average business ability of the farmers, and, to some extent, the social or co-operative spirit of the community.

THE MOTOR TRUCK AS A COMMUNITY INSTITUTION WILL BE INCREASINGLY IMPORTANT.

AMONG the passengers sailing on the White Star Line S.S. "Megantic" from Montreal, May 29th, was Mr. F. B. Caswell, who is enroute to Paris to attend the International Chamber of Commerce meeting, which opens June 20th.

He is General Sales Manager of the Champion Spark Plug Company of Toledo, and Vice-President and General Manager of the Champion Spark Plug Co. of Canada, Limited, of Windsor, Ont.



# Rosenheim and the Equus Caballus

Pinched (With Permission) From "Timken Magazine." Sketches by CLYDE E. DARR

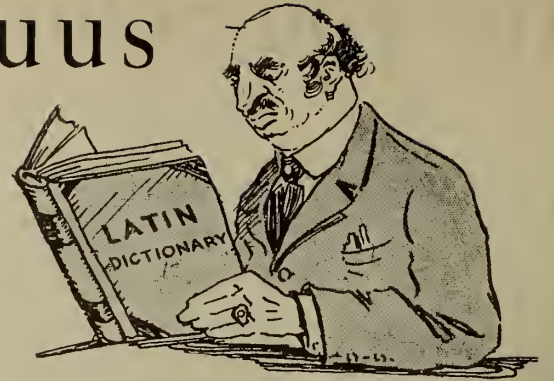

"MEYER, do you think the Equus Caballus has got a chance to be a profitable propersition in this country?" asked Max Rosenheim, proprietor of the Scotch Woollen Mills Emporium, high-grade men's and boys' clothing, of his friend, Meyer Goldman.

"Max, allus are you giving me them trick questions, which you know I ain't got any anser for. What you ask just now, which already I forget me the name, may be a new fillum in twelve parts, or a disease, and if you want to go ahead and explain, it is all right with me."

"Meyer, the dickshunary is a thick book like your head from one side to the other, and it ain't to be expected that right off you can tell what ever one of the words mean, so I ain't laffin at your ignorance of somethin' I didn't know myself till the other day. Equus Caballus is a horse."

"A horse it is. Well, I ain't surprised. Such names they have it is a wonder they can remember them at all. I heard Abe Figelbaum the other day talkin' about the entries at New Orleans and he calls them Slippery Elm, Skeerface, Hesabear, Hubbub, and all I want to say if you are takin' any of his tips and bettin' on the races you have my symperthy."

"No, Meyer, nothing would I have to do with a crook like Abe Figelbaum, especially after the trick he done at Herman Feldman's party, where he breaks a pat hand and spoils my draw in just a friendly game, where it was arranged I should get four nines. Equus Caballus ain't a horse, Meyer, but all horses—it's a family name, you understand, like Goldman or Rosenheim."

"But, what's the idee, Max? You ain't got a horse, and I can't see why you should be interested."

"Well, Meyer, it is this way: Mose Morgenheim, who counts himself a relative of mine because his brother's divorced wife married a second cousin of Rachel's, he comes to me and he wants to borrow some money. He is in the harness business, and, when I tells him that what with the way ottermobiles and trucks are commin' into such general use I don't figger that the harness trade is going to boom, right away he has his anser ready, and it is that a corporation what is called the Horse Publicity Association is going to spend a million dollars in the next two years to prove that the horse is more economical, safer and better than motor cars or trucks, and, when I tell him that it will take more than a million dollars to prove somethin' that ain't so, he invites me to attend a convention what has been called. I go with him because I been workin' pretty hard and feel that I need to see a good comedy to cheer me up.

"From all over the country comes men what are engaged in the hay and grain business, buggy manufacturers, harness makers, horseshoers, whip makers, robe makers, saddle makers and other industries dependent upon the noble animal, Equus Caballus, which was what a high-brow professor called the horse at the convention. Everybody cheered when

the head of a veterinary college got up and said he had never owned an ottermobile, and, 'God granting, he never would,' but lookin' the crowd over I would have bet money that practically everbody who cheered found an inner tube or a spark plug hangin' on their Christmas tree. Meyer, I have heard ottermobiles get some hard knocks from fellers what had tire trouble, but never have I heard such unanimous condemnation as what them guys handed out to Ford, Cadillac, and the feller what did so much to help win the war, General Motors. It seemed to be the opinion that the horse had a mean trick played on him when a human being invented something that could go faster, farther, and work harder without restin'."

"The biggest point claimed was that lots of people every year are killed by ottermobiles, while deaths from horse accidents are gettin' fewer and fewer. Every speaker on the program mentioned this. Of course I was only mildly interested, and it seemed to me that it might be true, but, due to the fact that you see a horse on the street only now and then, while ottermobiles and trucks are always in sight. I kept still, of course, but I wanted to get right up and say



that I never knew of a ottermobile deliberately killin' anybody. That it didn't kick, bite or run away of itself, and that practically every ottermobile accident to either pedestrian or driver is due not to the machine, but to carelessness. You can leave a machine standin' anywhere that parkin' is permitted and it won't get hungry, paw up the earth or kick an innocent bystander, and you'll find it there when you get back, providin' you got a good lock.

"And, Meyer, the sentimental stuff what they handed out, with a little girl recitin' the 'Ride of Paul Revere,' and me thinkin' all the time that Paul rode a horse because that was the quickest way of goin' in those days and that if he'd had a six-cylinder car he could have roused more people and carried the news further. I ain't denyin' that the horse has played an important part in civilization, but so did the sailing ship and the spinning wheel. And, when one speaker wept over the horse's affection for man, I got out my handkerchief, too, so I could cover my face to hide my grin. Meyer, you can raise a horse from a colt up and treat him like one of the family, feedin' him sugar and pettin' him like a child, but, if you go out for a horseback ride and a highway man comes along and knocks you over the head, what does the friend of the family do? Where the yellowest kind of a mongrel dog would bite the thief in the leg and hang on till pried off, this here noble animal, the horse, just stands still till the robber climbs in the saddle, and then he gallops away like you was a perfeck stranger to him. A horse ain't got any affection, mighty little real sense, and no loyalty at all. So this here sentimental appeal don't make much impression on me.

"One of the resolutions read like this: 'To save from neglect and extinction the noble animal which has been man's truest and most useful friend, and which is to-day one of the nation's greatest producers of wealth.' The way I look at it, Meyer, if a man really believes that a horse is his best friend, I ain't

got any objections to his buyin' one and keepin' it in his backyard for the children to play with, but, if the horse is to-day one of the greatest producers of wealth, there ain't no need of callin' conventions to prevent its extinction. It takes four years to breed, raise and train a horse, and after that he can work eight or nine hours a day, travel ten miles an hour for not more than two hours without rest, and last just a few years before old age or hard work kills him. To feed him takes the crop of five acres of ground every year, he is subject to every human disease and a lot more, carries germs, and his stable is the breeding place of the greatest enemy of the race, the house fly. On the other hand one big ottermobile factory turns out 3,000 cars every day, and three hundred truck and motor car factories in the United States can produce more potential horsepower in one hour than all the horses born since Columbus discovered America could deliver.

"And, Meyer, I done a little investigation about members of the convention and I found that the hay and grain dealers all had motor trucks and that the rest of them also had ottermobiles for family use, and delivery cars where the business was big enough. And I figgered that them fellers was strong for the horse, because other people usin' him and buyin' their goods made it possible for them to give their families a new model each year.

"We're going to need horses on the farms and other places for a good many years, Meyer, but this here million-dollar proporganda ain't going to help nobody but the printers. Just as soon as the farmer gets money enough ahead you bet he quick buys him an ottermobile, and when he takes in more land he ain't going to depend upon teams when he can do more work at less cost with a tractor."

"Then I take it, Max, that you didn't mebbe loan Mose the money."

"No, Meyer, I did not. Mose he gets huffy and he doesn't speak to me any more. I might have loaned him what he wanted, because I guess his business is all right, but he got mad at me, so I didn't insist."

"What was the trouble over, Max?"

"Well, I just make a little joke and he ain't got any sense of humor. The society was wantin' suggestions for some kind of a trademark or symbol to put on their advertisin' matter and Mose he hunches me in the side and whispers: 'Max, you're a business man, what would you suggest?' Well, I wants to





be obligin' so I makes a suggestion and hurts Mose's feelin's."

"What did you suggest, Meyer? Alexander the Great on his horse what he called Buseffalus?"

"No, I told him I thought a good idea to use would be a horse chestnut."

"Well, Max, you sure ain't very enthosiastic about the horse, are you, but he helped to win the war, didn't he? Look at all the horses what the United States shipped to Europe."

"Yes, Meyer, when this here war come on the fellers what was runnin' it for us had the same old idee of the horse's usefulness, so they buy up all the old plugs along with good horses so there would be a mount for every offecer. But, Meyer, the old way of fightin' battles is now obserleet. You know it used to be the General would be mounted on his white charger, which was selected because it mace a good mark for the enemy sharpshooter, and he would wave his sword and holler for his men to come on, and they would dash forward, usually with fatal results for the General. Why, do you know, Meyer, that in the Civil War, at the battle of Lookout Mountain, there was more brigadier-generals killed in five

hours than lost their lives in the three months' battle at Verdun. The modern general he don't make himself conspicyeus on a white horse. He sits in a bomb-proof hut nine miles back of the lines and has a map stuck full of red tacks, which he contemplates while smokin' Y.M.C.A. cigaroots. 'We will at once attack this trench,' he says, but he don't tell his orderly to put the saddle on Old Faithful. He just reeches for the telephone and gives his orders in a clear voice. Then he puts on his slippers and reads the evenin' paper till its time to go to bed.

"Them there horses what they shipped to Europe was mighty useful, I'll admit, because meat was scarce up there close to the battlefront and them French fellers ain't got any prejudices about eatin' horse flesh.

"But in the fightin' territory they was a plumb failure, because there wasn't any general to ride 'em. It was the passenger cars, the trucks, and the tanks what did the work. If a horse was gallopin' toward the German lines, the enemy stood firm because here was nine days' rations comin' and they would brave any danger to capcher the noble anermal as near the whole as posserable, but, when the tanks

come a crawlin' forward, they run for cover.

"If we ever have another war I don't believe horses will be in such demand as in the past. The Generals ain't going to take unnecessary risks when they can telerfone, and the gasoline engine is stronger and more reliable."

"Say, Max, you own a farm, and don't you use 'on it horses with which to harvest your crops?"

"I do not, Meyer, at least any more, for, believe me, a good healthy horse with a normal appetite could, in one winter, eat up all the proffit I make from the farm. I buy me some horses at different times when I get me that farm, and, Meyer, no man what is ignerent should ever buy a horse or believe what the other feller tells him about the anermal. Such a bunch of liars they invarrybly are. I have bought balky horses, blind horses, spavined horses, and horses which died overnight. One kicks me, an' another one steps on my foot so I have to wear crutches for a month.

"Some people mebbe can farm with horses at a proffit, but for me the experriment is allus a loss. I think I make a trip to Kansas City look over them trackters and mebbe buy me one."

# Railroads Vital to Implement Industry

By E. H. McCARTHY

Traffic Manager, Hyatt Roller Bearing Co.

**D**URING the past winter I have seen office men of mediocre physique spend night after night in various railroad switching yards out in the snow and rain to make sure that their shipments were moved. I have seen these same men roll up their sleeves alongside freight handlers and help transfer stuff from one car to another. I have seen farm tractors do switching work day after day—switching that technically was the duty of the railroads. I have known manufacturers to send men across several states to get a trunk or a suit case, full of parts to be used for completing machines—machines that were often sold at a loss.

One Michigan manufacturer, within the next few weeks, will begin operating a fleet of trucks between his factory and his sources of supply—in some instances a distance of over 700 miles!

It is hard for the public to realize just how many difficulties have beset the manufacturer in making deliveries during the past two years. Never before have so many different obstacles had to be overcome.

Although, on every hand we hear cries of greater production, I believe that a thorough analysis would convince anyone that it is more a question of transportation, for even with disturbed labor conditions the majority of delays in manufacturing can be traced directly, or indirectly, to delays in transporting material.

During the past three years transportation has been the "neck of the bottle." No one has been free from the effects. The manufacturer has been delayed in getting his material. He is dependent upon the steel mills and the parts makers, and they in turn are dependent upon the mines, and then, again, the mines are dependent on other manufacturers for mining equipment with which to operate.

**T**HE farmer is dependent on many phases of the manufacturing industry to supply his needs, and absolutely everyone is directly dependent upon the farmer.

Thus we get an endless circle of dependencies, and, analysing the situation from its various angles, the wonder is that things are moving along as smoothly as they are.

Since 1915 the volume of freight handled in this country has increased 45 per cent. During the same period the increase in number of freight cars amounts to only 2 per cent.!

This deficiency in freight car equipment is seen reflected in express service: when a shipper realizes the congested freight condition, he routes more and more of his goods by express. As a result of this condition, express shipments have increased more rapidly than ever before. Few express cars have been built during the past three years. To-day it is quite the practice to ship commodities by express that, under normal conditions, would have always gone by freight. This has been a substantial factor in increasing prices.

The railroads are the arteries through which the very life-blood of the nation flows. These arteries

are hardened, they no longer expand, the blood pressure is high. Goods can not be freely transported from one section of the country to another, and, as a result of this, our whole industrial system is out of joint.

**T**HE only way to compensate for the deficiency is to speed the flow of products through the available channels. It is up to the traffic men—both with the railroads and with private corporations, to accomplish this. It is their duty to judiciously apporportion material and transportation equipment—to protect both buyer and seller, to use every piece of equipment to the greatest possible advantage, to safeguard the public interests—always observing the basic economic rule, "the greatest good to the greatest number."

It is a "man's size job." It is an unending job. Conditions are serious—if we give up to them they will immediately become disastrous!

More work, more thought and less talk are needed. High-brow legislation will not change the economic condition. The problem is practical, rather than political. We have no time to spend in proving who is to blame. It's a question of making the best of things by putting forth constructive effort and real "sweat."

Traffic men cannot remedy the situation single handed. Others must do their share. The dealer in farm machinery should have a clearer understanding of the problems that confront the manufacturer, and

the farmer should appreciate the dealer's efforts to supply his needs. The public, as a whole, should maintain a liberal-minded attitude towards the railroads.

**T**RANSPORTATION is the neck of the bottle. Immediate individual profit is quite incidental. The big problem is to keep the wheels of industry turning. It is up to everyone to face the situation and consider things fairly. The problem affects everyone directly or indirectly. It's up to everyone to do his part toward alleviating the conditions.

Equipment should not be delayed. The fact that a man is willing or able to pay a high demurrage charge does not entitle him to hold up a freight car. Such a man is not only subjecting some other shipper to hardship, but he is placing himself in a position where the railroads will not be inclined to give him preferred service the next time he needs a car. To needlessly detain equipment is a crime against the economic welfare of the nation. The man who is guilty of it is an enemy of society.

Cars should be loaded to a maximum capacity, which, generally speaking, is 10 per cent. above the rated capacity. In other words, a car marked 60,000 pounds should be loaded to 66,000 pounds.

Consignees should promptly take up L.C.L. shipments in order to avoid freight house congestions.

Buyers of all kinds should anticipate their requirements as far ahead as possible.

*Idle talk will accomplish nothing. Intelligent co-operation and hard work will save the day.*

## Canadian Spark Plugs for England

**T**HE Champion Spark Plug Co. of Canada, Limited, whose new plant at Windsor, Ont., was opened some months ago, has just made its initial shipment of Canadian spark plugs to England. This shipment establishes a precedent in the automobile accessory industry in the fact that a Canadian manufacturer is shipping into a field which formerly supplied this country, rather than looking to Canada for its supplies. Such a shipment is but one more step towards the readjustment of the balance of trade which has been so badly distorted during the past year or so.

The Champion Spark Plug Co.'s Windsor plant is the largest in Canada devoted exclusively to the manufacture of spark plugs. Its production capacity is approximately 35,000 spark plugs a day.

Thousands of spark plugs were shipped last year by this company to Great Britain, Australia, India, Japan, France, Italy, Spain, Belgium, Mexico, etc., etc. It is the intention of the Champion Spark Plug Co. of Canada, Limited, to handle all this company's export business with the British Isles and other British possessions. At the present time, there are in Canada and United States over 300 manufacturers of motor cars, motor tractors, motorcycles, aeroplanes, marine and stationary engines, who make Champion Plugs a part of their equipment.



Give David the Rock and He Will Make Goliath's Head Ring.  
—Ireland in the Columbus "Dispatch."



This article on batteries, by Arthur M. Glover, is the second to appear in M. T. I. on this important subject.

Mr. Glover, who is head of the service department of Nash Motor Sales, Toronto, Ontario, is an expert in all branches of repair work. These battery articles are in a series of four, dealing with every phase of the subject.

The first article dealt with general details of a battery while in the present one battery testing is explained.

The other two articles will deal with charging, assembling and general repairs.

## DETAILS IN STORAGE BATTERY SERVICE

### Article No. 2—Testing the Battery

By A. M. GLOVER

not only ruin a battery but will make the hydrometer reading worthless. To add acid is to "dope" it, and "doping" anything never produced satisfactory results. As a matter of fact, sulphuric acid, of which the liquid mainly consists, does not evaporate; it is only the portion of water mixed with it to bring it to the right strength that evaporates and needs replacing once in a while. If a battery shows low reading on the hydrometer and will not come up, it is poor policy to "dope" with acid. It is some internal trouble that is causing the condition which must be remedied by legitimate means.

**I**F the hydrometer reading shows up well and still the battery does not operate satisfactorily, make a voltmeter test on each cell. These tests should always be made while the battery is in use by turning on the lights, blowing the horn, or operating the starter. When the battery is at rest, the voltage will build up, but will not hold out when any demand is made on it.

Every so-called 6-volt battery consists of 3 cells joined together, the negative part of one cell to the positive part of its neighbor, and so on, giving us two end posts, one negative and one positive, marked neg. or pos. Each cell, when fully charged, should read 2½ volts, making a total for the three cells of 7½ volts. If any one of them shows considerably lower than his neighbor, there is something wrong; it should be taken out and the trouble located.

We will go into the question of completely disassembling a battery in a later article and will now recite a few of the troubles that are liable to cause trouble in connection with a battery.

The main trouble, I have always found, has been the failure to keep all terminals and connections clean and tight. Special attention should be given the positive post, for, unless this is kept tight and clean, a greasy, green corrosion takes place, which eats the cable right away in time. This corrosion is caused by the fumes rising from the battery when it is charging, especially if the vent plugs are of the old type facility design. To prevent this, make a good connection and tighten up all bolts; then melt a little parowax and pour it over the part. This will make an air-tight covering and keep everything in first-class shape. Of course, if the battery cables have to be tight, so do all the cables leading from it to the starter switch and starter. Don't blame your battery until you have made sure the trouble does not lie at some other spot. A battery is pretty near fool proof; it gets blamed for a lot of things that are not its fault at all.

See that the bolts holding it down in its receptacle are tight. Nothing will develop trouble so quickly as a loose battery bumping around a holder. This will loosen parts, cables, jar plates, break lugs, and cause leaks.

**I**N some cars the battery is placed under the floor boards, and in this position it gets covered with all the flying mud and water when the car is used in bad weather. Some protection, such as a sheet of rubber over the top, will help considerably, and prevent foreign substance getting in when the vent plies are taken out to add distilled water or examine the condition of the battery.

To sum up:

The liquids of a battery, the technical name of which is "Electrolyte," should read between 1,250 and 1,300 to be in good shape.

A battery should never be used when this reads below 1,100.

The voltage of a battery should read 2½ volts on

each cell and not fall below 2 volts per cell when in use. All connections must be kept and given an air-tight covering of wax.

The battery should be held firmly in its position on the car.

Acid should NEVER be added to a battery; all it needs is pure distilled water.

The top of a battery, where exposed to the weather, should be protected in some way, as, for instance, by a sheet of rubber.

In stocking liquids, such as electrolyte or distilled water, it must be remembered that absolute purity is essential. The slightest trace of metallic impurities in a battery will ruin it.

Distilled water should be stored in glass or earthenware stoppered containers. If distilled water is not available it is permissible to use pure rain water. If rain water is used it should be caught in a clean glass or earthenware vessel. Rain water that has come through a metal spout is useless for storage battery purposes as it becomes more or less

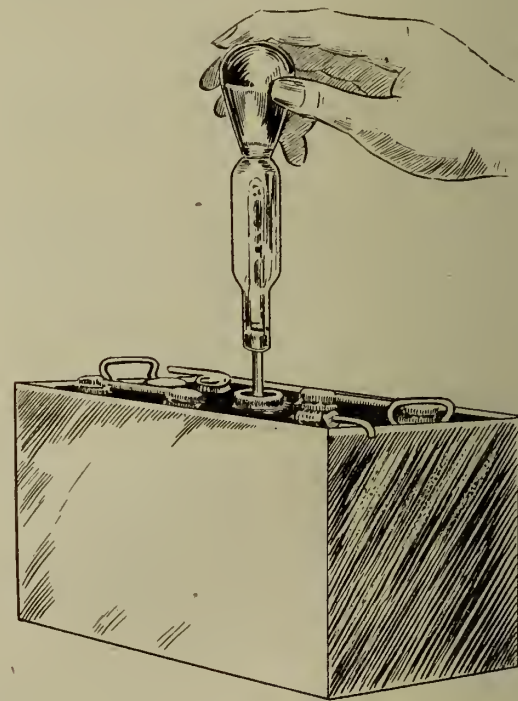

Method of using the Hydrometer.

impregnated with iron or zinc. This iron or zinc in the water when brought in contact with the sulphuric acid causes an injurious chemical action to take place. A good deal of battery trouble can be traced to the use of impure water.

It is an excellent idea to keep the water you are using in a bottle with the hydrometer, as shown in illustration; by this means the hydrometer is always ready to hand for filling purposes and in a safe place where the risks of being broken or of collecting dirt or other matter likely to be injurious are practically eliminated.

**E**LECTROLYTE should also be stored in a glass or earthenware vessel. Lead containers may also be used but as lead containers are somewhat rare around the small garage, our choice is narrowed down to the glass or earthenware.

If you decide to put up a bench solely for batteries, it is a good plan to cover it with sheet lead. This will prevent acid, that may be spilled when filling, from destroying the surface of the bench.

**W**HEN a battery comes into you and the owner claims it is down, the first operation is to test the acid by means of a hydrometer. This is an instrument consisting of a rubber bulb on the end of a glass tube, which, when compressed, and the end of the glass tube inserted in the vent holes of the battery below the level of the liquid, will, when released, suck up a quantity of the liquid out of the battery. Inside the large glass tube is a smaller one resembling somewhat a thermometer, marked off with figures from 1,100 to 1,350, or thereabouts. In addition to these figures it is marked "empty," "half full," and "full."

As the liquid is drawn into the large tube by means of the rubber bulb, the small inner glass tube will be seen to float in it, and the depth it floats determines, to a great extent, the condition of the battery. The place to take the reading is at the time where the liquid strikes the small tube, when it is floating freely. If the battery is fully charged the small tube will float high in the liquids, and if it is almost down, it will hardly float at all; indeed, in a very bad case it will not float at all.

A fully charged battery should read 1,280 to 1,300, and a battery unfit for service will read 1,100 or so. When it reads as low as this it should on no account be put to work before receiving a charge from an outside source and brought up to the normal again. A reading should never be taken immediately after distilled water has been added to a battery. The distilled water being lighter than the acid already in the cells will remain on top for some time, thus preventing a true reading being taken as to the condition of the battery. After the battery has been in use a day or two you may take a reading and get an accurate result.

Sometimes acid has been added to a battery by an inexperienced person. This will

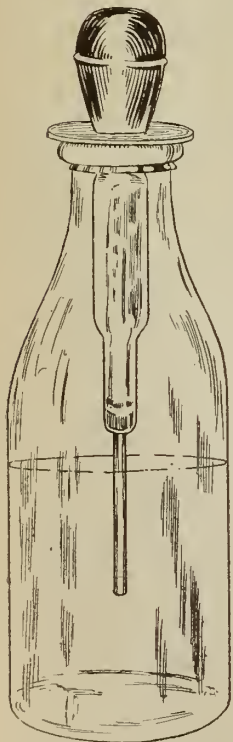

A handy place for the Hydrometer is here shown.



# Pembroke has a *Real* Service Garage

Selling Service as Important as Selling Automobiles or Trucks

"SELLING service, we consider, is the most important aspect of the automobile business to-day. It is even more important than selling cars, trucks or tractors. Without a comprehensive and satisfactory service system, no automotive concern can hope to remain long in the business."

Thus spoke H. Lamothe, Superintendent of Pink's garage, Pembroke, Ontario, in discussing with M. T. I. the main points on which the success of his concern rested.

Every alert business man we talk to, no matter what his line may be, is saying the same thing—SERVICE and BETTER SERVICE. It is the key to success.

*Sell your service properly and it will sell your merchandise.*

The proprietors of Pink's garage long ago realized that service was a regular business department of their business. Their garage is equipped for giving every kind of service. Their salesmen are educated in the best service methods; they know how to approach a customer, when to sell a car, truck or tractor, and when to sell advice.

One of the cast-iron rules of Pink's garage is—*never sell a man an article for which he has little or no use.*

Through their service system they have built up one of the finest garages in eastern Ontario; and, what is more important, a reputation for good work, dispatch and fair dealing.

THIS up-to-date garage came into being about eight years ago. It is really an offshoot of a blacksmithing and forging concern founded by Thomas Pink.

About sixty years ago Mr. Pink settled in Pembroke and started in a small way as a blacksmith, making lumbermen's tools. He succeeded so well, that today he is the head of a well established concern operating under the name of Thomas Pink and Company. Their tools are shipped all over the world, and are well known, even as far away as Australia and New Zealand.

In 1912 the automobile business attracted this live concern. They started at first to do repairs only, in a small place which held two cars. In the following year they built a fine steel garage, adding a brick front to it in 1914.

As the business grew it became necessary to put the garage on its own footing as a separate unit under a manager and superintendent, with a complete staff of salesmen, repairmen and office clerks. The organization, as it stands to-day, consists of the following: Manager, J. Canty; superintendent, H. Lamothe, and twenty-two employees, including salesmen, repairmen and a book-keeper.

TO take care of their business outside of their immediate territory, sub-agents have been established at Cobden, Eganville, Bechburg and Chalk River. These sub-stations give the same service that is provided by the central garage.

Pink's garage does not belong to that class of business which rises up during the night like a

mushroom and disappears at noon like a smoke cloud at the first breath of wind. It has been built up gradually on a sure foundation, and can now be acclaimed a lasting and monumental structure.

It has twice stood the ordeal of fire. In June of 1918 a destructive fire struck the city of Pembroke, sweeping away half of the city, and Pink's garage with it. Temporary quarters were secured but by one of those peculiar twists of fate, exactly one month from the date of the first calamity, another fire swept the city and again Pink's was destroyed. In spite of this second misfortune, Thomas Pink and Co. determined to carry on. Again temporary quarters were sought and found—this time in the curling rink—where they conducted their ever growing business until January of 1919, when they took up quarters in their present splendid garage. It was specially constructed by them, and, so far as human ingenuity can make it, is absolutely fire-proof. "In spite of the fact that we have been burned out twice," said Mr. Lamothe, "we are doing a bigger business to-day than we ever did in our history."

The new garage is 76x84 feet, two storeys high and constructed of steel and concrete. The show room is

The equipment in the workroom consists of a lathe, drill press, electric hand drills, valve grinders, bearing and burning stand, oxy-acetylene welding outfit, battery charging outfit, overhead carrying system, etc., etc.

Pink's garage specializes in battery work. Their charging outfit is a Lincoln generator, which charges seventy-five batteries at a time. In the racks upwards of 300 batteries can be stored conveniently. They find that this branch of their business is growing rapidly, more especially since the new Ford models are being fitted up with a starting device.

The paint shop and varnish room is on the second floor; it is 20x24 feet and six cars can be placed on a working basis. Three expert painters are kept busy in this department all the year round.

In the workroom there is a unique machine which Mr. Lamothe, the superintendent, calls a starting machine. It was built by themselves and is intended for starting and suppling up stiff engines. It consists of a short shaft with two grooved pulleys, on which the rear wheels of the car rest. A pulley on the end of this shaft connected to the main shafting by a belt supplies the power. When a car is placed in this simple device it can be run for an

indefinite period, or until the stiffness has been removed. This is a great convenience and time-saver; the old method of pushing a stiff car by hand is done away with and replaced by a quicker and less expensive one.

THE arrangement of accessories in the stockroom is specially noteworthy. All parts are carefully sorted out, grouped into boxes and the boxes ticketed showing the article, price and part number. The boxes are arranged in racks around the walls and in pyramid shaped cabinets. The tires are kept in a separate room in the same orderly manner.

"We are very proud of our accessory and tire departments," said Mr. Lamothe, "and make it a point to keep both departments well-stocked and in proper order. We always keep on hand about \$20,000 worth of accessories and about \$10,000 worth of tires. No matter what rush there may be we can always cope with it, as we operate on a wide margin.

Our territory is a large one and able to absorb an almost unlimited number of automobiles, trucks and tractors. We have worked it thoroughly and spent a lot on advertising and demonstrations and, we are pleased to note, our work is bearing fruit. The work is not so hard now; we have educated our public and convinced it that our service and business methods are right and we are in the business to help, not merely to sell something.

"Our salesmen are on the road all the time canvassing and distributing literature. We advertise every week in the papers, both in Pembroke and the sub-towns. Circular letters are sent out at regular intervals to prospects, and at all important road crossings we have mileage finger posts from twenty to thirty miles out bearing an inscription: "So many miles to Pink's Garage."



This picture illustrates the fine appearance of Pink's garage. It is equipped with every modern device.

built alongside the garage; it is 20x40 feet, one storey, and constructed of the same material as the garage. The garage and show room are exceptionally light. The windows are numerous and arranged so that the maximum amount of daylight is obtained.

The ground floor of the garage is occupied by the accessory department, "in and out" department and the offices. There is a wash rack on this floor fenced off from the main part by a metal partition.

The workroom is on the top floor and is accessible for cars by an electric elevator. All the equipment necessary to give the highest form of service is to be found in the workroom.

NO customer who purchases a machine from Thomas Pink and Co. need worry about service matters. They are in a position not only to give the ordinary repair service, but to manufacture and machine new parts. With the aid of the blacksmithing and forging department they can supply almost any part required for a repair with the least possible delay. They also make their own slip-covers, cushions and seats. Expert trimmers are employed to do this work.



# The Farm Electric Plant and the Dealer

TEN thousand Canadian farmers are anxious and willing to spend ten million dollars this year for electric plants and water systems, but they are not going to buy until the dealers show them just what they are to get for their money.

Suppose ten years ago you had just taken up the agency for a car. There were none in your territory, and you had no demonstrator, and you figured that John Brown of Brownville could afford one, and suppose some fine day you hitched up your horse and rig and drove out to see him, and told of this wonderful new machine. You told him that he could make the ten miles to town in almost the time he would be hitching up the old horse and rig and that he would be riding with the greatest of comfort, gliding along on tires filled with air, and that all he had to do was to sit up and "give her more gas," and when he was through with his trip, it could stand in the barn for weeks and would not eat its head off in oats, and that he could take out the whole family, and of all the other wonderful things a car does. Don't you think that Mr. Prospect would say, "Yes, that sure is a fine machine, but I would like to see one before buying."

Yet there are hundreds of dealers in Canada to-day trying to sell lighting plants in exactly this way. They are talking about pushing a button and flooding the barn with light, and turning the switch and doing the family washing, and giving the farmer dozens of other appealing arguments, but he is not going to buy until you show him that "It can be done," and just as you do, he will buy.

THERE are to-day in Canada more than 150,000 farmers with cars and every one of these is a prospect for a lighting plant, so that the ten thousand mentioned above need not worry you about exhausting the market this year.

The United Farmers of Quebec at their Convention held in Montreal on July 2nd, 1919, passed many resolutions, but none more important than this: "Considering that the farmer's wife and children are compelled to help the bread-winner in all of his farm work; that his working hours are longer than those of the city mechanic who furthermore enjoys a home supplied with running water, electric lighting, and other comforts unavailable to the majority of farmers." This shows that the farmers are doing some deep thinking about the use of electricity on their farms, and are not only willing to buy, but are crying for relief from the shortage of labor and the greater attractions the city holds for their sons and daughters.

The Honorable J. E. Caron, Minister of Agriculture for the Province of Quebec, in an interview given at Quebec on May 17th, 1920, said: "I am no prophet, for already the situation has reached a stage where production is being affected due to the lack of farm hands. The cities with their mirage of happiness and entertainments have increased the rush from rural centres to industrial ones to such an extent that it is time to sound the alarm and to warn farmers and the country people that they should remain the kings of the land. Farmers' sons have been tempted to enjoy themselves with other pleasures in preference to the rustic ones, and the cities have become the rendezvous of the flower of our youth. I may be asked how the problem may be settled; that apparently there is no possible means of bringing back a farmer's son who has been in the city, to the soil, but steps must be taken to attract those who are still on the land of their fathers to remain there. A farmer's life has been greatly improved in recent years as far as conditions of farming are concerned, but his living condition has not changed very much. I think a campaign should be immediately started in the Dominion to keep the people on the soil, if farms are not to become fields without any cultivation, and unless this is done within the next two years, without being a pessimist, I fear life will become intolerable throughout the country."

HOW is the farmer to know that an Electric Power and Light plant is the answer to one of his problems unless the dealer shows him? Every machine now in use on the farm has replaced, at some time, an old and expensive method of getting

By T. R. CAMPBELL

work done. The modern plow, grain drill, binder, etc., are not real necessities, but there is no doubt in the farmer's mind now that he should use them in order to produce his crop at a reasonable cost. Their benefits are so self-evident that they are now considered as necessities. Before their use, things were done by hand, just as dozens of other things are still done by hand. Their use will also be discontinued just as soon as the farmer learns how to do this work with electricity.

I received, recently, a sworn statement by one farmer, W. E. Shetrone of Le Raysville, Pa., showing that in October, 1919, his net saving from his electric plant was \$105.00. This saving was made by running his milking machine, separator, churn, and pump electrically, and is only one of hundreds of cases where similar great savings are being made.

POWER and Light is not an agency or a side-line, but is a real, profitable, pleasant, all-year-round business. It offers very great opportunities, chiefly because the dealers now starting are getting in on



T. R. CAMPBELL  
Manager Power and Light Department, Northern  
Electric Company.

the ground floor. Every sale means a good turn-over with satisfactory repeat orders for accessories. Most of the plants on the market to-day have given satisfactory service for six or seven years, and are as well standardized as automobiles.

There are two distinct types—the direct connected and the belt driven. Each type is used in connection with a storage battery and in most cases is designed to operate at 32 volts.

The direct connected set has an engine, generator and switch-board built in one compact unit, and is self-cranking and self-stopping. The splash oil system is most generally used and with proper regulating instruments on the switchboard, satisfactory and economical service is obtained.

The belt connected type of set has a generator and switchboard mounted on a base, and furnished for use from the farmer's own engine. Most belted plants have the switchboard equipped with a voltmeter, ammeter, regulating rheostat, and cutout; the rheostat being used to adjust the plant to variable engine speeds.

Just which plant is most suitable will depend upon the requirements. If a milking machine is to be used, the belted plant will give exceptionally good service, provided a three to four h. p. engine is used. Care should be taken to see that in selecting the belted plant, an engine of the proper size is used. The particular advantage of the belted plant is that the engine can be used for other work while charging the batteries, and unless the engine has this extra capacity, this benefit is not obtained. Any engine under 2½ h. p. should not be considered for a belted plant where it will be called upon to do other work

while charging, and if the work from the pulley is heavy, a larger engine should be used.

ELECTRIC plants have too frequently been called "lighting plants." The farmer will not readily spend several hundred dollars to obtain an improved method of lighting, but when you show him the many uses for power and household devices, he is interested, and when you have convinced him of the benefits to be obtained from all these things, he is sold.

Farmers are not worrying a great deal at the present time in trying to determine what particular plant is the one to buy, but are keenly interested in knowing what the plant will do—what it will cost—and how long it will last.

The number of years of service is perhaps of greater importance to the farmer than the other questions, but this is a matter which neither experts nor manufacturers can furnish much information on, for the number of years of service which a plant will give depend more on the care and attention it is given than on any other feature. Not knowing in advance the kind of treatment the plant will receive, it is difficult to say how long any particular machine will last. The plants furnished by well-known concerns who advertise their product extensively and have a reputation for furnishing reliable goods can be depended upon to give a great many years of pleasing service. Many of the first models have been in use more than six years, and are still in first-class condition.

The operating cost will also depend largely upon the attention which the user gives. With a well-installed belted plant used with a kerosene burning engine regularly used for operating a milking machine or pump, the extra cost for lighting service will be negligible. In fact, most users have failed to discover any increase in the fuel consumption.

AFTER all is said and done, the particular make of plant is a whole lot like determining between Holstein, Ayrshire, or other breeds of cattle—all have their followers, and each may be the "best" in the eyes of the man who has had success with them. The really important thing is—electric service.

The national advertising campaigns now being carried on in the various farm papers are bringing hundreds of inquiries from all parts of Canada for information and prices on plants. The dealer handling the products of these companies benefits by this general publicity as the inquiries will be sent direct to him, but the dealer must put real selling efforts into this line to establish himself as the man to go to for electric plants and accessories. Many dealers handling old-established lines, the completeness of which has meant substantial business for them, are now confronted with a territory well filled with their product, whereas in the lighting plant business, the whole field is yours, and although thousands of plants have already been sold in Canada, the field may rightly be considered as undeveloped. The day of the electric plant has arrived, and you, Mr. Local Dealer, are the logical man to handle this newest and fastest growing business. What part of the ten millions are you to get this year?

## Support Good Roads

THE Border Cities, Windsor, Ford, Walkerville, Sandwich and Ojibway, will lend their support to the 1920 International Good Roads Tour of the Michigan Pikes Association, July 14 to 29.

The Essex County Automobile Association held a meeting recently to handle the details and appoint a committee. The committee is composed of officials of the E. C. A. A. and is as follows: President, A. W. Reid; secretary-treasurer, J. F. Duncan; manager, W. H. Adams.

The tourists will cross the river at Windsor on July 14 around four o'clock and an open-air meeting in the interests of good roads will be held immediately after their arrival. After the meeting the tourists will proceed to the camping site and on the morning of July 15 the actual start will be made from that point. The Border Cities will be represented in five cars and twenty tourists during the entire tour.



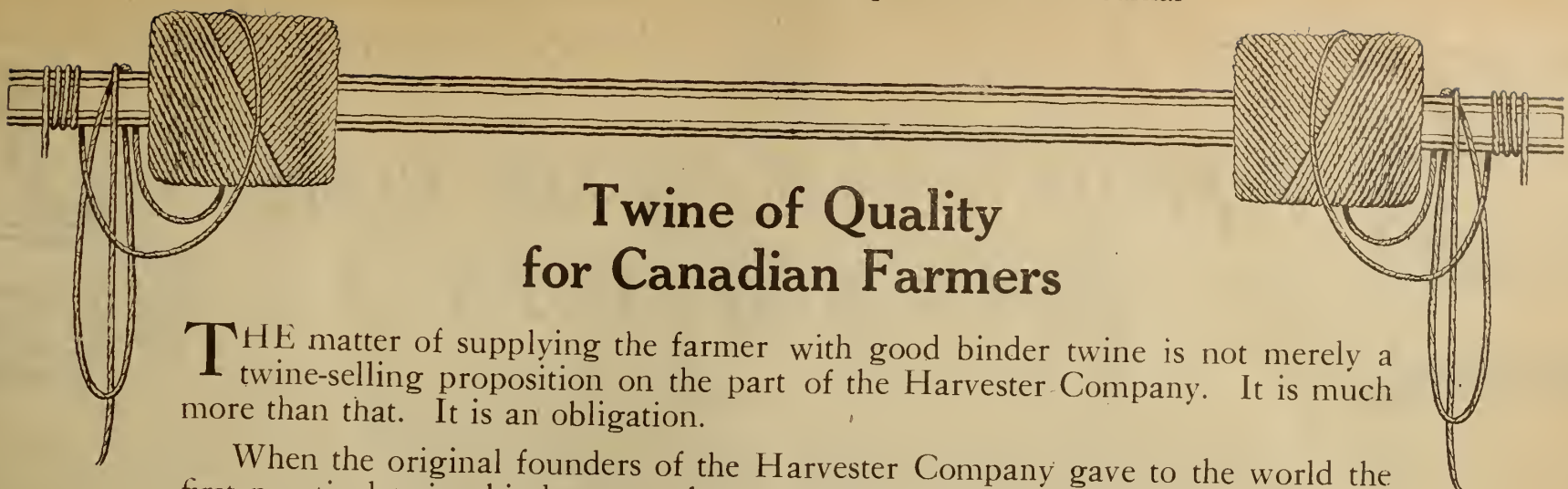

## Twine of Quality for Canadian Farmers

**T**HE matter of supplying the farmer with good binder twine is not merely a twine-selling proposition on the part of the Harvester Company. It is much more than that. It is an obligation.

When the original founders of the Harvester Company gave to the world the first practical twine binders over forty years ago, they automatically assumed the responsibility of insuring satisfactory operation from these machines. They successfully met that obligation with good twine.

To-day this inherited responsibility is greater than ever. Proper operation of thousands of good binders is threatened by the many brands of cheap, inferior twine. It is part of the Harvester Company's obligation to protect the owners of these machines against the hazards of such twine. This protection is rendered by supplying the farmers of Canada with twine of quality that insures sure tying and full length. Such twine bears one of these names:

Guaranteed for **INTERNATIONAL HARVESTER COMPANY**  
OF CANADA LTD  
HAMILTON CANADA

WESTERN BRANCHES — BRANDON, WINNIPEG, MAN., CALGARY, EDMONTON, LETHBRIDGE, ALTA.,  
ESTEVAN, N. BATTLEFORD, REGINA, SASKATOON, YORKTON, SASK.

EASTERN BRANCHES — HAMILTON, LONDON, OTTAWA, ONT., MONTREAL, QUEBEC, QUE., ST. JOHN, N. B.

**McCormick  
Deering  
International**

*Your ambassador to the farmer.*

Let the International Engine represent you and prove the merits of International Machines.



OPERATES ON KEROSENE

**A**PPPOINT a small crowd of dependable **International Kerosene Engines** to go and look after your interests on the farms of a new picked list of your customer-prospects.

Whenever you place one of these little brothers of International tractors, it will come immediately into year-round demand by man and woman. Today in thousands of farm homes it is considered the greatest handler of drudge-jobs to be found on any market. It is acknowledged the most sensible engine for pumping, washing, separator-turning, churning, grinding, shelling, etc. Made in 1½, 3, 6, and 10 h.p.

Do not underestimate the power of **International Kerosene Engines** for building good will. Trade thrives on satisfaction. Take these engines out on your territory and let them go to work here and there in their dependable satisfactory manner. They will prove the merits of **International Farm Machines**. Ask the International blockman about the complete and thorough selling assistance we have ready to supply.

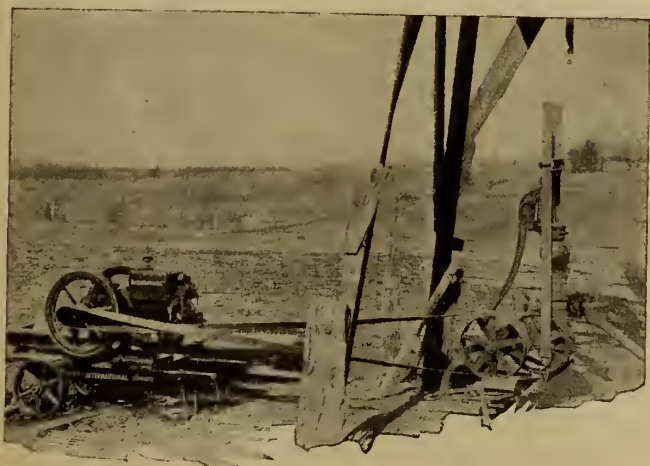

**INTERNATIONAL HARVESTER COMPANY**  
OF CANADA LTD.  
HAMILTON CANADA

WESTERN BRANCHES — BRANDON, WINNIPEG, MAN., CALGARY, EDMONTON, LETHBRIDGE, ALTA.,  
ESTEVAN, N. BATTLEFORD, REGINA, SASKATOON, YORKTON, SASK.  
EASTERN BRANCHES — HAMILTON, LONDON, OTTAWA, ONT., MONTREAL, QUEBEC, QUE., ST. JOHN, N. B.





# SHOP NOTES FOR THE GARAGE MAN



## Materials Employed in Tire Work

By F. H. SWEET

THE stocks and compounds commonly used in tire repair work are many, and as is true of other forms of construction, none but the best should be employed. Some tire repairmen use cheaper grades of stock because the margin of profit is larger; but this is poor policy, and any one who wishes to establish a business will find that only the best selected material should be employed. If this is bought from reputable makers, at fair price, there can be no question as to quality. Cover stocks are used for retreading and padding, and vary in composition and gauge from 3-64 to 3-32 inch thickness to meet different requirements. Some retreading stock is in the form of thin sheeting other forms, known as "camel-back," are calendered thick in the center so that it answers the same purpose as though several layers of the regular retreading stock were used. "Inside patching" is a rubber stock cured on one side and uncured on the other, made especially for repairing tire tubes. Frictioned fabric is a textile product of high grade long fiber cotton, impregnated with rubber composition, while rebuilding fabric is frictioned material having a skim coat of pure gum in addition. "Bare-back" fabric is material frictioned on one side only, while breaker strips are narrow widths of frictioned fabric in various sizes, ready for application to tires without cutting, save for length.

When an inner tube is blown out badly it is necessary to cut it at that point and use what is called a tube splice, this being made with a short piece of tubing with each side tapered that joins the ends of the ruptured tube. Cements vary widely, but should always be similar in composition to the rubber upon which they are to be used, as to make a good joint by the vulcanizing process the cement should contain the same percentage of sulphur. This is another condition in which the experienced man scores, as if care is not taken in the selection of the cement, very unsatisfactory results are obtained in vulcanizing. Most rubber cements consist of pure Para rubber dissolved in naphtha or other solvent, to which is added other substances, such as shellac, as thickeners, or various specific dryers to make the cement dry quicker. Where tenacity is especially desirable, other gums, such as mastic and gumlac, are used. So many excellent cements on the market have been tried and tested that the repairman will be unwise attempting to compound his own, especially when these can be purchased as cheap, if not cheaper than the raw materials and made on the premises. The results are more uniform with commercial cements.

Many motorists cannot understand why tire repairing is a somewhat costly process, but it will be evident that great care is necessary at every stage, from preparing the tire and applying the fabric and rubber, to the final curing, and that a certain knowledge is necessary which can only be

gained by experience. Then the materials employed are costly. There is a good deal of hard work needed, and in these days experienced workmen command good salaries. Then the repairman must stand back of his work, and not infrequently loses money in endeavoring to please customers by making gratuitous repairs upon tire failures which were due to the motorist's abuse, and not that the work is faulty.

### Some Tube Repairs

TIRE tube work includes repairing punctures, blowouts, cuts due to pinching in application, or by poorly fitting security bolts, and inserting new valves. After locating the opening, the rubber is slightly roughened with a piece of emery cloth for an inch and a half on all sides of the hole, the surface is cleaned thoroughly with benzine, cemented, filled in with unvulcanized stock or a patch and cured on a flat plate. Cuts are cleaned carefully to insure absolute cleanliness, the edges are cemented and brought together with unvulcanized stock to form a union, and cured, as in the case of a simple puncture. Blowouts or large punctures require different treatment after the rubber has been thoroughly cleaned, as the size of the hole seriously weakens the tube. The area around the opening is well cemented, both inside and out, inside patching material is placed inside the tube, the space between the edges of the hole filled in with unvulcanized material, stitched carefully, placed on a flat plate and cured. The length of time in heat is governed by the quantity of material and quality of the tube to be cured. This will vary from 10 to 25 minutes at a steam pressure of from 35 to 50 pounds. In applying valves a piece of rubber known as the valve pad is vulcanized to the inside of the tire instead of the inside patching, this serving as a reinforcement and forming a firm base for attachment of the valve.

There are a number of occasions where the valve stem of an inner tube becomes defective, due to either the stripping of the external threads so that the pump connection cannot be se-

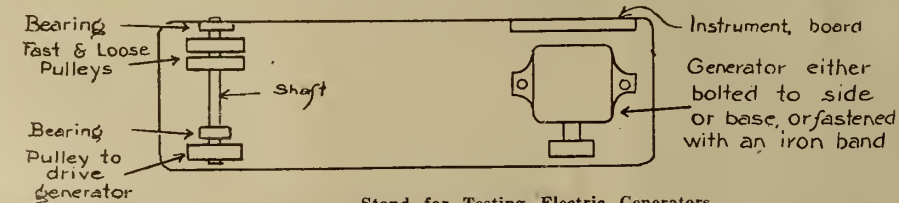

Stand for Testing Electric Generators

curely screwed on, stripping of the valve thread inside which prevents the removal of the check valve and bending of the stems due to careless handling in removing it from the rim. Another common failure is shearing off the projections on the valve inside by which it is intended to be unscrew-

ed, which means that the valve cannot be taken out when it becomes leaky. Of course, any one of these defects temporarily destroys the usefulness of the inner tube. If that member is comparatively new or still serviceable, a new valve stem may be easily inserted.

The repairman who does tire work

### STAND FOR TESTING ELECTRIC GENERATORS

THE following cut illustrates a small inexpensive bench stand for testing and adjusting generators. By the use of this device any generator can be adjusted conveniently, and with the best results, while in position on the

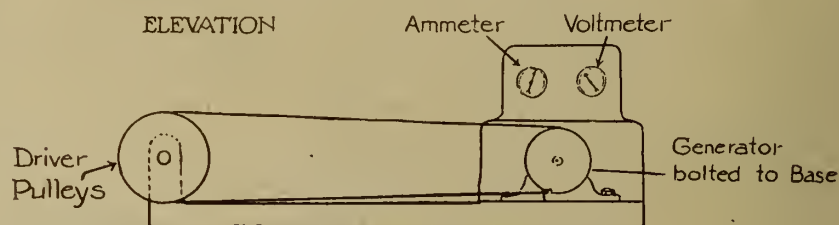

Stand for Testing Electric Generators

will find it advantageous to cut out all the valve stems from old inner tubes which may be in his possession, and even when an inner tube is entirely worn out the valve stems may be in good enough condition to warrant saving them until an opportunity presents itself for using them.

A defective valve stem may be taken out of the inner tube without injuring it by releasing the clamping nut and removing it and the casing spreader, then removing the corrugated washer which holds the tube against the button-shaped inner end of the stem. The portion of the tube adjacent to the stem can be carefully loosened and the button end separated from the rubber by forcing the stem into the tube. Some gasoline or naphtha may facilitate loosening of the valve base if cement has been applied. If a pair of special tire pliers is at hand their point can be inserted into the hole and the hole can be stretched until it is sufficiently large to pass the button end of the stem through. The button end of the new valve stem can be placed in a hole when this is elongated and some cement may be applied to the contracting surface of the stem end as a lubricant to facilitate entrance into the interior of the tube. The pliers are then removed and the tube allowed to constrict around the valve stem. Some cement is placed on the corrugated face of the clamping washer, then the spreader is put on over the stem and the clamp nut screwed down and tightened. By partially inflating the tube and submerging the stem portion in water one can easily determine if a satisfactory repair has been effected.

automobile. It is simple in construction and can be made by any repairman at little cost. It consists of a solid iron—or wood base—having a shaft with two light pulleys and one loose pulley. The fast and loose pulleys are belted up to shafting giving about 500 revolutions per minute. The pulley at the end of the driving shaft is connected to the generator by means of a belt or chain. An ammeter and voltmeter are mounted on a small instrument board fastened to the stand as shown.

A battery can be cut into the line as a final test of the charging capacity of the generator under load.

A. M. GLOVER.

### PORTABLE ELECTRIC HAND DRILL

THE Amold type "B" Drill shown in the cut is a seven-pound off-set drill of 3/8-inch capacity.

The makers say it is particularly adapted for automobile construction and garage work. It is conveniently controlled by a push switch which is installed in the side handle. The body is made entirely of aluminum, carefully machined, and is thoroughly strong and substantial in construction.

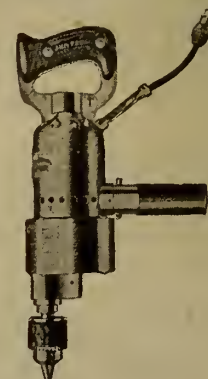

The planetary system of gearing is used, and is also compounded with gears to the off-set chuck spindle. This system dispenses with the overloading of the motor under the most adverse drilling conditions. The motor is universal and equipped with plain antifriction metal bearings for the armature shaft. The gears are heat treated and run in oil.

It is manufactured by the Amold Electric Tool Company, West Haven, Connecticut.

Care should be taken in replacing the clamp plate or spreader so that its greatest length is lengthwise of the tire. The function of this is to protect the tube at the point at which the valve is attached. It also aids in holding the casing in place on the rim to some extent.





A well-tried, and well-trusted friend, the

# Frost & Wood Binder

Thousands of prosperous and progressive farmers in all parts of Canada recommend it. They have used it and know that it does splendid work. It's an easy binder to sell to the farmer who needs a new machine

Many binders will cut grain that is standing nice and clean, but for tangled, heavy, hard cutting, the farmer certainly needs the strength, adaptability and light draft of the Frost & Wood Binder.

The Frost & Wood Binder is built of the strongest, yet lightest materials that money can buy. We use high-grade, dust-proof roller bearings at every friction point, which makes for long life and easy work.

Handy levers work the reel to any position and bring the grain to the cutter bar no matter how tangled or short it is. The Frost & Wood Knotter is very simple and get-at-able. It is a sure tier.

The capacity of Frost & Wood Binder elevators is very large—that means they will handle the heaviest as well as the lightest crop in a satisfactory manner. A special arrangement of the lower elevator roller overcomes any tendency for grain to hang on inside divider.

Big power wheel ensures plenty of power, strong bracing, gives enormous strength; improved cutter-bar construction and many other good features make this the ideal Binder.

Let us send you catalogues showing the famous Frost & Wood Hay-making and Harvesting Machinery—and full line of Implements.

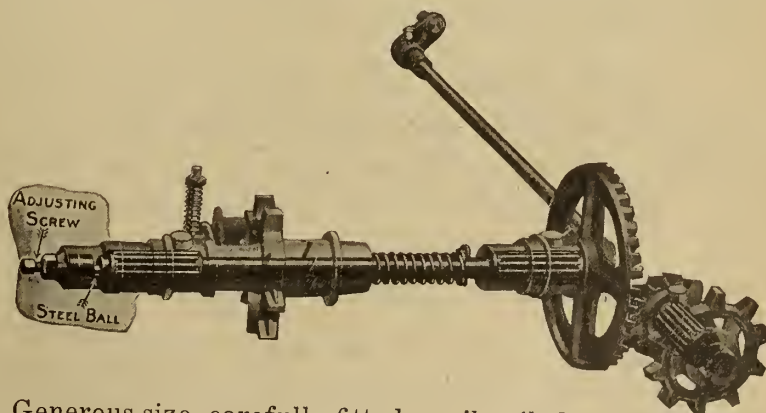

Generous size, carefully fitted, easily oiled and dust-proof bearings in all working parts.

**The Frost & Wood Co.**  
LIMITED

Montreal SMITH'S FALLS St. John

*Sold in Western Ontario  
and Western Canada  
by*

**Cockshutt Plow Co.**  
LIMITED

BRANTFORD, ONTARIO





## Standardize Your Tractor Business with the Turner

If you sell tractors, you realize how important it is to handle a standardized tractor. If you don't sell tractors, now is the time to find out about the standardized Turner.

The Turner Simplicity is standardized throughout. There are no freak or experimental features. Each unit has been proven by actual tests in the field. The Turner is built for practical farm use. Our experience in building Farm Power Machinery for 19 years is back of every Turner Simplicity.

Reserve power without excessive weight, simple control, three point suspension, Hyatt Roller Bearings, low center of gravity, burns either kerosene or gasoline—these are a few of the features that make the Turner Simplicity a dependable Tractor for dealers to sell.

Many Tractor dealers are building up a growing profitable business by selling the Turner Simplicity. Write or wire today for full particulars of the Turner line.

Turner Tractor Sales Co.  
Winnipeg, Man.

Power Farm Machinery Co.  
Edmonton, Alta.

Turner Mfg. Co., 441 Lake St., Port Washington, Wis., U. S. A.  
*Builders of Turner Tractors and Simplicity Farm Engines*

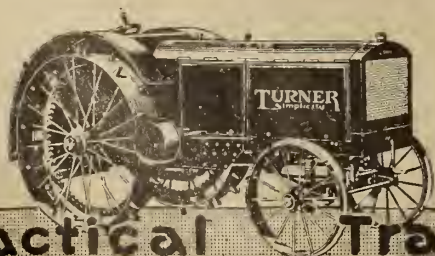

**The Practical Tractor**

## NEWS — OF THE TRADE FOR THE TRADE

### ONTARIO

**DUNDAS.**—M. Oakes will shortly open an auto repair shop and warehouse.

**SMITH'S FALLS.**—W. J. Tye is handling the Massey-Harris line of implements.

**GUELPH.**—The International Malleable Company has decided to enlarge its plant.

**NEW HAMBURG.**—Jonas Jantzi is opening a garage and repair shop on Main street.

**TILLSONBURG.**—C. H. Fisher has purchased the implement business of W. E. Moore.

**BRAMPTON.**—The Messervey Batteries will build a large factory here, to be completed during the summer.

**LINDSAY.**—It is reported a company will be formed here for the manufacture of a new form of automobile rim.

**TORONTO.**—The Ford Motor Co. is erecting a two-storey garage on Main street at a cost of approximately \$60,000.

**WINDSOR.**—The Kelsey Wheel Co., Ltd., manufacturers of auto wheels, hubs, etc., are erecting a new building 50x150 feet.

**SMITH'S FALLS.**—W. H. Frost, president of the Smith's Falls Malleable Castings Co., Ltd., died recently in his 73rd year.

**HAMILTON.**—The Canada Side-Car and Manufacturing Co., 65 York street, is now manufacturing both scout and heavy model side-cars.

**KINGSTON.**—The garage, known as Angrove Bros., has changed hands and is now operating under the name of Blue Garages, Limited.

**WINGHAM.**—W. Gannett, implement dealer, has purchased a building on Josephine street, where he will carry on his implement business.

**BRAMPTON.**—A new Ford repair shop has been opened by C. Cousins. All Ford repairs will be handled and a full line of parts and accessories carried.

**TORONTO.**—The Canadian General Electric Co. plan to erect a new factory in West Toronto. The main building will be 70x390 feet and four storeys high.

**KINGSTON.**—The Kingston Auto Sale Company, Limited, is a new concern. They have the Studebaker agency and handle all repairs and accessories.

**ST. THOMAS.**—The executive of the local board will make an attempt to induce the Dodge Motor Company to establish a branch factory in St. Thomas.

**PETERBORO.**—The General Electric Co. has secured the contract for four electric generators for the St. Margaret's Bay Power Development, Nova Scotia.

**KINGSTON.**—M. Oberndorffer, proprietor of Clarence street garage, recently secured the agency for the Franklin car. He also handles the Dodge agency.

**BRANTFORD.**—The Champion Ignition Company will establish a factory here for the manufacture of spark plugs. Work on the new plant will be started at once on a site covering 15¼ acres.

**SMITH'S FALLS.**—The Smith's Falls Malleable Castings Co., are remodelling and re-equipping their No. 1 plant, which has been closed down for the past six years.

**OAKVILLE.**—The Oak Tire and Rubber Co., are planning to extend their factory by the addition of another storey, which will enable them to double their present output.

**TORONTO.**—The Paxor Auto and Engineering Co., Ltd., has been incorporated recently and purpose moving from the present premises on Richmond street to Oxford street.

**WALKERTON.**—The Sterling Twine Co., Ltd., has been incorporated with a capital stock of \$100,000. The company has purchased a factory and machinery and expects to have the plant in operation during the summer.

**KITCHENER.**—Members of the Nurses' Alumnae Association of the Kitchener and Waterloo Hospital have been active on a money-raising campaign to purchase a \$4,000 motor ambulance. They fully expect to reach their objective.

**WALKERVILLE.**—A new concern, the Gotfredson-Joyce Corporation, Ltd., has been formed for the purpose of manufacturing a 2½-ton motor truck. The company expect to produce at least one thousand trucks during the coming year.

**BEAMSVILLE.**—Work has commenced on the new factory being built by the Premier Tire and Rubber Co., Ltd., for the manufacture of inner tubes, tires and rubber specialties. The new company is incorporated with an authorized capital of \$300,000.

**GUELPH.**—The Gilson Manufacturing Co., makers of gas engines, tractors, etc., are extending their premises, adding a two-storey brick structure, 140x80 feet, to their main building, to be used as a machine shop and assembling room.

**TORONTO.**—The Riverdale Garage, Limited, will commence operations immediately on what is claimed will be the finest garage in the city. The building will be of brick and steel, 68x327 feet and two storeys high, and will cost in the neighborhood of \$150,000.

**TORONTO.**—W. M. Findlay, who has been connected with the Willys-Overland Co., Inc., Toledo, Ohio, for the past five years, has rejoined the forces of the J. J. Gibbons Advertising Agency, Toronto. Previous to going to Toledo Mr. Findlay was with this agency for three years.

**GALT.**—The city council will petition the Ontario Government for power to impose a local tax, not exceeding \$1 per horse-power, on automobiles; the money raised to be used towards paying the cost of repairs to pavement required because of the automobile traffic.

**GODERICH.**—C. Richardson, implement dealer, has leased the store at the corner of Hamilton and St. Andrew's streets, where he will move his implement business to. The store he now occupies will be used by him for handling a line of pianos and talking machines.

**TORONTO.**—Recently a large jar containing a strong acid fell off a motor truck at the intersection of Bay and Adelaide streets, and smashed causing the liquid to flow down the street. Traffic was held up by the police. One motorist took a chance and his tires exploded—so fast did the acid eat into the rubber.





## Farm Housework and Goodyear Belts

**J**UST as indispensable to the household power as to the efficient operation of the great tractors and threshing outfits in the fields is the belt that transmits the energy of the stationary engine to the new time-saving and labor-saving machines used by the farmer's wife. Made of the same stock, and with the same care, as the big free-swinging Goodyear Extra Power on the thresher, the Goodyear Extra Power Belt on the churn, or the washing machine, or the lighting plant, reveals the same qualities of economy.

A Goodyear Belt needs no breaking in. Whatever the service in which it is employed, it goes straight to work. It requires no belt dressing. Cold and damp do not affect it, for a Goodyear Extra Power Belt is waterproof. Flexible and friction surfaced, it holds the pulleys at high speeds or low, on light drives or heavy with the same sure grip and full delivery of power.

Noting its reliable work, day in and day out, many a farm wife recognizes the truth in her husband's remark that a Goodyear Extra Power Belt is "the best help on the farm." The housewife, as well as the farmer, finds much of value and interest in the Goodyear Farm Book. A letter to the Goodyear Tire & Rubber Co., of Canada, Limited, Toronto, Ont., will bring a copy.

**GOODYEAR**  
 MADE IN CANADA  
**EXTRA POWER BELTING**



## If you hope to sell him something else



If every time you sell a piece of equipment, a machine, or a part, you are hoping it will lead to a further sale, you'll be interested in the "Vessot" agency proposition. "Vessot" Feed Grinders will give your customer more satisfaction, less trouble than any other grinder you could sell him.

He will not require to have any particular knowledge of milling to get just the results he wants—the "Vessot" is so easy to adjust and operate.

Stake your reputation on the "Vessot." "Vessot" sales will open the way to sales of other farm equipment.

Write the nearest branch of the International Harvester Company for our worth while agency proposition.

Inventors and Manufacturers

S. Vessot & Co., Joliette, Quebec

Sold exclusively in Canada by

International Harvester Co. of Canada, Limited.

Branches: Calgary, Edmonton, Lethbridge, North Battleford, Regina, Saskatoon, Estevan, Yorkton, Brandon, Winnipeg, London, Hamilton, Ottawa, Montreal, Quebec, St. John.



Grinder with Elevator and Bagger

## BIRDSELL CLOVER HULLERS

HULL AND CLEAN

Common Red, Big English or Mammoth, Alsike, Crimson and Sweet Clover Seed

BUILT IN THREE SIZES FOR CANADA

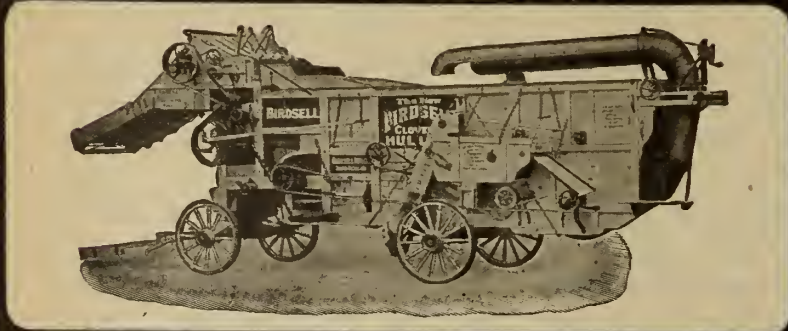

BIRDSELL "QUALITY" IS SUPREME

THERE are Birdsell Hullers in use today that have been in the field every season for 40 years. That means SERVICE—it means ECONOMY—it means SATISFACTION. It is easy to discern why 35% of all Hullers in use throughout the World are of Birdsell make, when you know what SERVICE they give.

We invite you to write or call on us. Our traveling representative will call on you at your request.

BIRDSELL MFG. CO., TORONTO

FOOT OF GEORGE STREET

## News of the Trade

### MANITOBA

WINNIPEG.—The Franklin Motor Car Sales Co. has opened a showroom and service station at 421 River Ave.

WINNIPEG.—A new concern, Buckingham-Walmsley, will erect an up-to-date garage on Smith street at a cost of \$45,000.

BOISSEVAIN.—E. T. Johnson, accessory and hardware dealer, among other improvements to his store, has added an auto accessory display case.

ELPHINSTONE.—T. Wilson has built a new garage, 80x300 feet. It is equipped with up-to-date machinery and capable of handling every branch of automobile repair work.

BRANDON.—J. A. Jacklin has been appointed assistant to Manager Brosnahan at the local I.H.C. branch. Mr. Jacklin was formerly a blockman, operating from the Winnipeg office.

WINNIPEG.—Part of the educational program at the Canadian Good Roads Association's seventh annual convention at Winnipeg in June will be the building of a piece of roadway by experts.

WINNIPEG.—A new enterprise, to be known as the Auto Auction Sales Co., has opened offices and showrooms at 159 Portage Ave. East. The company specializes in the selling of used cars by auction.

BRANDON.—The Brandon Board of Trade has decided to ask the assistance of the Manitoba Motor League in securing one of the main highways running north and south from Minnedosa to Boissevain.

WINNIPEG.—The Dominion Motor Car Company, Canada Bldg., Donald street, are introducing the flat rate system of repair charges, and are advertising in the local press a schedule comprising 539 separate repair operations.

### SASKATCHEWAN

DENZIL.—E. J. Smallacombe has opened a new implement business here.

TATE.—An implement business has been opened up here by W. A. McKenzie.

MOOSE JAW.—A new business, the Battery Service Co., has been established.

TANTALLON.—Charles A. Mitchell has sold out his implement business to T. Hulme.

CUPAR.—A warehouse has been opened by W. L. Hubbs, who will handle farm implements.

BROWNLEE.—Quaine and Quaine, implement dealers, has taken the agency for a line of automobiles.

MARYFIELD.—R. T. Whitely, implement dealer and blacksmith, has dropped his blacksmith business and is concentrating on implements.

WEYBURN.—L. A. Wylie, formerly I.H.C. collection manager at North Battleford, has been assigned to the Weyburn branch in the same capacity.

### ALBERTA

CHERHILL.—The Massey-Harris agent at Cherhill is W. T. Stromquist.

EDMONTON.—A line of implements has been added to their business by the proprietors of the Empress Garage.

CALGARY.—The Sexton Service Station, a new battery service station, has been opened at Seventh avenue and Centre street.

NANTON.—A new automobile and tractor concern, the G. and B. Motor Co., has opened up. They handle all kinds of repairs.

EDMONTON.—C. W. Lochard has been appointed assistant manager of the I.H.C. branch. He filled a similar post at Lethbridge.

CALGARY.—W. McMaken, formerly I.H.C. blockman at Lethbridge, has been appointed assistant manager of the Calgary branch.

PEACE RIVER.—Zabel, McCashin and Co. have succeeded the Fraudle Motor Co. Besides handling automobiles and repairs, the new concern also carry farm implements.

CAMROSE.—Announcement is made of the incorporation of the Francoeur Engine and Thresher Co. The new company will handle threshers and stationary engines.

EDMONTON.—McKinley, Adin Co., dealers in tractors and farm implements, have opened a new warehouse at 9818 102nd Ave., near Rice street market. They have the agency for the Cletrac tractor and Oliver farm machinery.

### BRITISH COLUMBIA

VERNON.—The Galbraith-Spiers Company, implement dealers, has been succeeded by J. S. Galbraith and Sons.

VANCOUVER.—The Begg Motor Company has been appointed distributor for National trucks in British Columbia.

HUNTINGDON.—Frank Brown has taken over the blacksmith shop on First street and is converting it into an up-to-date garage.

KAMLOOPS.—The Webb-Barford Machine Company has succeeded the Webb Machine Company. The new concern has the agencies for several well-known implement lines.

NEW WESTMINSTER.—The New Westminster Automobile Club has gone on record as opposed to the proposed increased tax on automobiles outlined by the Minister of Finance.

VICTORIA.—Among the new proposals to raise the city's revenue is one to license every automobile driver within the city limits. The fee for the license would be about \$5 and applicable to everyone driving a car, whether for business, pleasure, or hire.

VANCOUVER.—Traffic truck sales have increased to such an extent in the Dominion that the manufacturers are considering establishing a Canadian factory, and Vancouver has been suggested as the probable site. H. H. Hawke, general manager of the Traffic Motor Truck Corporation, visited the city recently to confer with the Hayes-Anderson Motor Company, Ltd., on the future Canadian policy of the company.

### QUEBEC

MONTREAL.—A new factory has been built by the Hall-Thompson Co., manufacturers of chemical automobile specialties, at 3150 Mance street.

MONTREAL.—The Montreal Arena Company has erected and will operate what is said to be Montreal's most up-to-date garage. It is equipped in every way and has many conveniences such as a club room for chauffeurs where refreshments can be had at reasonable rates, and books, magazines, etc., etc.



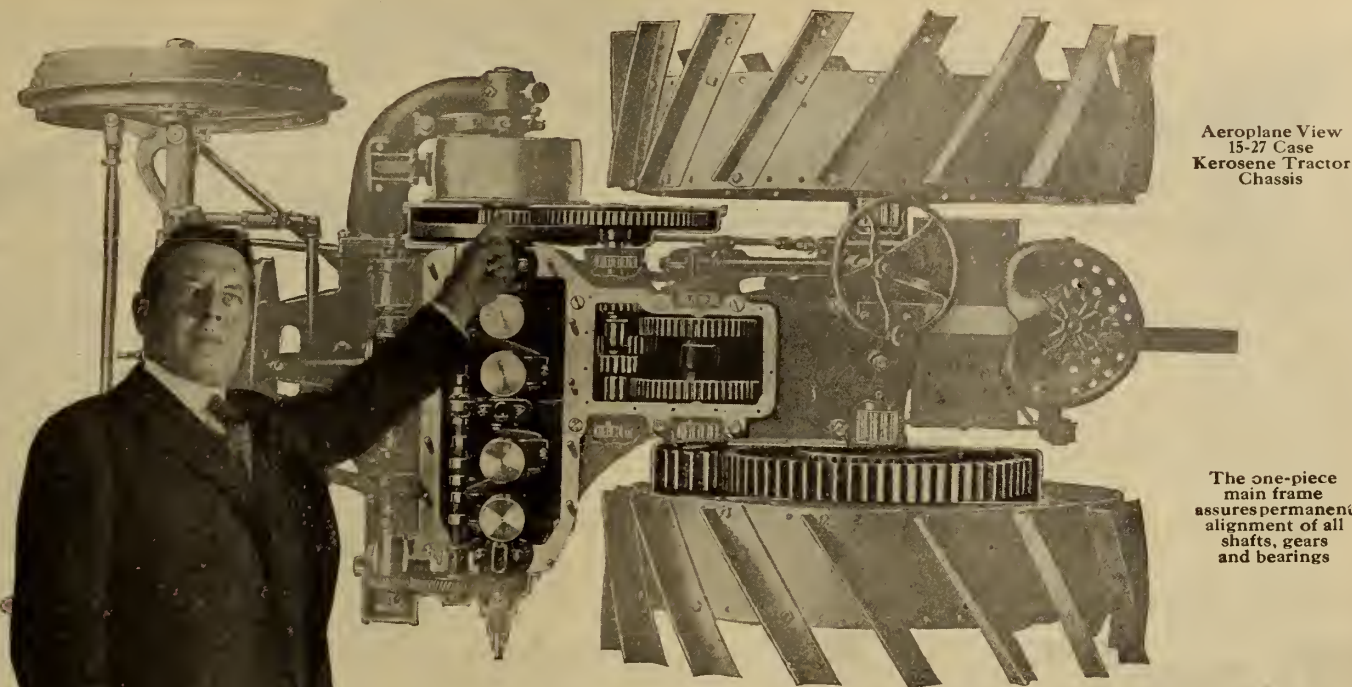

Aeroplane View  
15-27 Case  
Kerosene Tractor  
Chassis

The one-piece  
main frame  
assures permanent  
alignment of all  
shafts, gears  
and bearings

## Cut Steel!

**Y**OU'VE got something to tell your prospect about the superiority of the Case Kerosene Tractor. Its snappy lines and handsome finish are very attractive to the eye, but away down inside, sealed beyond the reach of dust or daylight, are the work and wear-defying "innards" that give your customer all his money's worth, and more. Show him!

Start with the source of power—the motor mounted cross-wise on the frame. This permits *spur gears* throughout—the best and simplest transmission possible in a tractor. No chains, sprockets or bevel gears between crank-shaft and bull-gear.

Take your prospect along this path of power transmission. Be sure he understands that each gear is fine steel; that each tooth is precisely cut; and finally, that the entire transmission system runs in lubricant—in dust-proof housings.

So, throughout the entire machine. Each part of all sizes of Case Kerosene Tractors is the best that can be produced for its purpose, in material, workmanship, design—and in ease of selling demonstration to the prospect.

J. I. CASE THRESHING MACHINE CO., Inc.  
Dept. O-6, 345-9 Dufferin St., Toronto, Ontario  
*Making Superior Farm Machinery Since 1842*

To avoid confusion, the J. I. CASE THRESHING MACHINE COMPANY desires to have it known that it is not now and never has been interested in, or in any way connected or affiliated with, the J. I. Case Plow Works, or the Wallis Tractor Company, or the J. I. Case Plow Works Co.

**CASE**  
TRADE MARKS REG. U.S. PAT. OFF. AND IN FOREIGN COUNTRIES.  
**KEROSENE TRACTORS**

Look for the EAGLE, Our Trade Mark



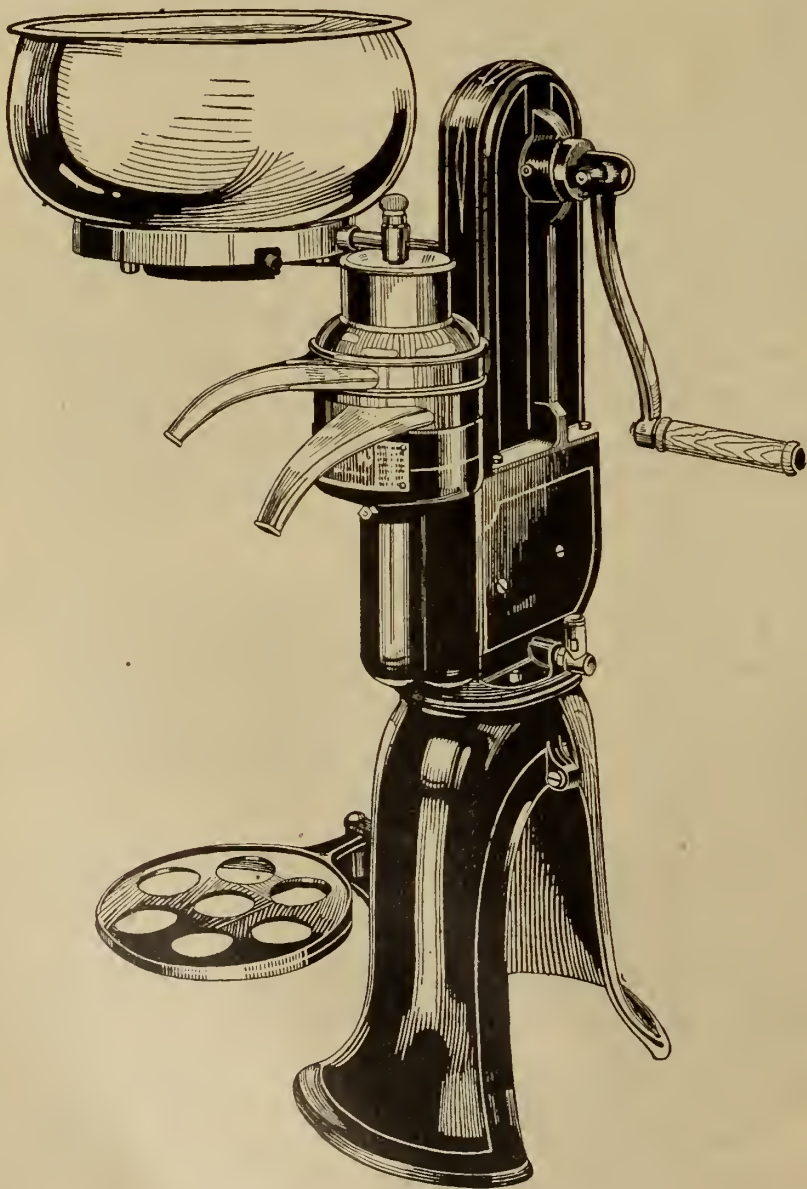

MADE IN CANADA

# Renfrew Sep

**A** GENTS are making remarkable progress and exceptionally good profits. They like to handle the Renfrew Separator because it is an easy seller and it gives the best of satisfaction to farmers who use it. Satisfied users here and there all over the country are constantly spreading the merits of the Renfrew Separator. These satisfied users are becoming more numerous all the time and making it easier for the Dealer to sell the Renfrew lines.

The Renfrew Cream Separator gets 99.99 per cent. of the butter fat out of the milk. It's a profit maker in that respect. It gets and saves cream that poor separators lose. The Renfrew is pleasing in appearance. Dealers are proud to sell it and users are pleased to show it to their neighbors.

All the gears run in a bath of oil inclosed in a dust-proof casing. There is absolutely no oil on the outside to gather dust and dirt. The crank is high and the supply can low. All these features make it attractive.

## The Renfrew

Head Office and Works: Renfrew

**IMPORTANT NOTICE:**

On account of increased  
be some new territories





*The Renfrew*  
**Cream Separator**  
**Gets All the Cream**  
 Guaranteed Closest Skimming  
**SKIMS TO 99.99% on TEST**

# Separators are Rapid Sellers

## The Scale

### Another Quick Seller

The Renfrew handy two wheel truck scale is the handy companion of the Separator. Many Dealers are now ordering the Renfrew Scales in car lots. The scales are easy to sell. Every farmer is a prospect for scales and they need one because without it they lose money.

Mr. Chas. Adderman, of R. R. No. 3, Ridgetown, Ont., says, "My scale made me Thirteen Dollars on a load of hogs, on which I would have been a loser."

Mr. O. Hadean, of North Temiskaming, Ont., says, "Saved me one time \$87.00 on a carload of hay."

The two men mentioned above have used the Renfrew Scale for over six years and have not had to buy any repairs.

## Scales and Separators

### A Handy Combination

Every farmer is either a prospect for the Renfrew Separator or the Renfrew Scale or for both, and Dealers appreciate this fact as they always make a sale.

## 100 per cent. Canadian

Both the Separators and the Scales are all Canadian, made by Canadian workmen with Canadian Capital. This is an exceptionally interesting point to Dealers.

### Our Co-Operation With Dealers

Dealers are ably supported in their work through our farm paper advertising, and in this way we are cultivating extensive fields for the Renfrew Cream Separator and the Renfrew Scale.

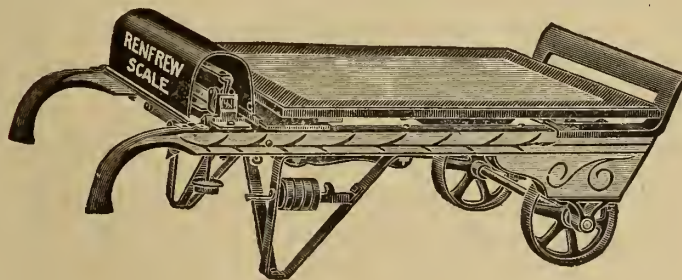

### Other Lines

Besides the Separator and Truck Scale, we include in our lines the Renfrew Oil Engine and The Happy Farmer Tractor.

# Machinery Company, Limited

, Ont.

Branches: Montreal, P.Q.; Sussex, N.B.; Milwaukee, U.S.A.

Anticipating more work, we are shortening up some territory consequently, there will be Live Progressive Dealers. Write us for our proposition, it will interest you.



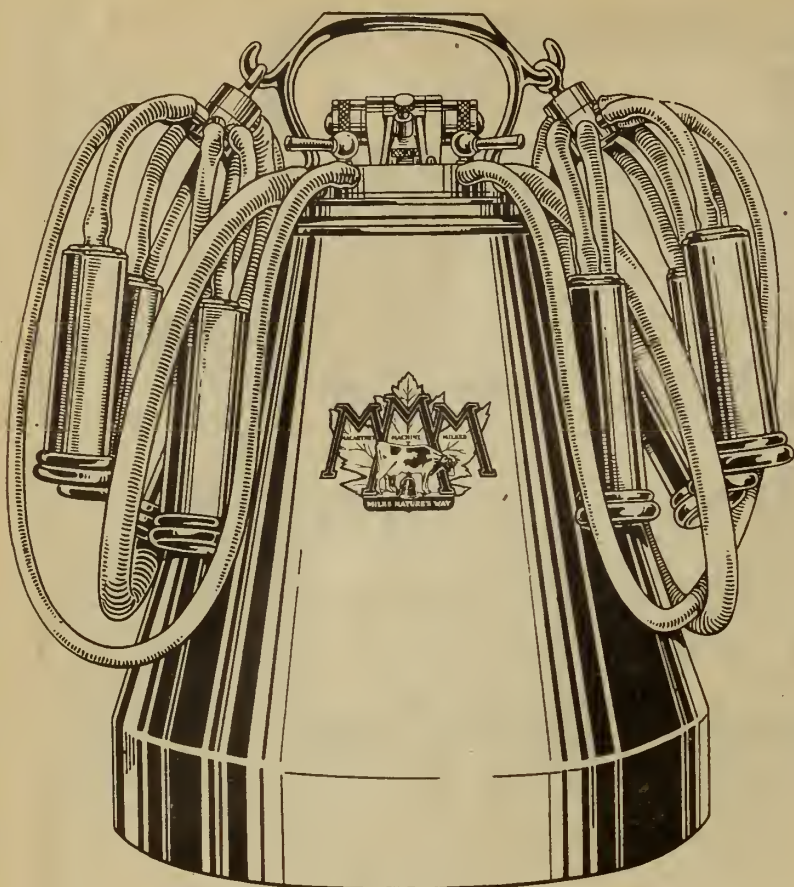

THE COW'S ADOPTED CHILD

## Will You Represent This Milker in Your Exclusive Territory?

To the live dealer, in a position to properly represent it, the **MACARTNEY MACHINE MILKER** will bring both prestige and profit.

Because the Macartney Machine Milker—100% perfect, efficient and durable—offers the man with cows the easiest and most practical solution of the prevailing labor problem.

This truth is being tellingly presented by means of a big advertising campaign in Canada's leading farm and dairy journals. It is creating the buying impulse in the minds of the farmers and dairymen right in **your** locality—and some one live dealer there is going to cash in upon it.

Will you be that dealer? **Now** is the time to decide. Quick action is advisable as territories are being rapidly taken up.

Write to-day for our agency proposition. Ask any questions you wish. Only—don't let this opportunity pass without at least investigating.

The  
**Macartney Milking Machine  
Co., Limited**

Ottawa

Canada

## Dairy and Household Supplies

### EARLY METHODS OF MILKING

FOR hundreds of years since milk has been one of the principal foods for mankind, milking has been accomplished with considerable difficulty. Although milk from cows, goats, camels, and other animals has contributed to the sustenance of mankind, and especially to the growth of infants and children, many people have wished and hoped for an easier and more rapid method of milking.

It was supposed that when the cow came to be the great source of milk supply the problem was solved, for the teats are, on the average, just about the right size for rapid, easy hand milking; and machinery was not considered to any extent in connection with milking. In fact, it is within the memory of older farmers that machinery first commenced to be used to any appreciable extent in agricultural operations.

About forty years ago, a well-known farm paper had an item about a milking machine that had been invented, and stated that all cows would soon be milked by machinery. It was about this time that Dr. De Laval, the inventor of the cream separator, began his first experiments with his mechanical device for milking cows, and the work begun by Dr. De Laval has been carried on and brought to completion in the form of the modern De Laval milking machine.

We have all heard more or less, in recent years, about milking machines, and a milking machine that can be operated successfully by anyone is the goal toward which all manufacturers are working. At Raymondale Farm, Vaudreuil, Quebec, there is in operation one of the prominent milking machines that has solved the problem. The management of Raymondale Farm is noted for progressiveness in all lines—buildings, equipment, cattle, and methods are up to date in every particular. The installation of a milking machine that could be operated successfully by anyone, found its answer in the De Laval after months of constant use without a single adjustment.

Discordant conditions at milking time cause a cessation in the secretion of milk. Secretion of milk is constantly going on; the time of milking and conditions must be pleasant or secretion of milk will cease, and "the cow will hold up her milk." With a machine like that used at Raymondale, harmony prevails, rapidity of operation obtains, and maximum production is the result. The action is gentle, but positive and rapid, all of which pleases the cow, which is absolutely necessary.

We have seen by the preceding statements how necessary harmonious conditions are for the proper production of milk in the cow's mammary organs at milking time. Therefore, if the pulsations, so called, of the milking machine come with absolute regularity, and the teat-cups are agreeable but positive in action, milking is accomplished time after time, month in and month out, getting maximum results, and the period of lactation is usually prolonged without injury to the cow in any way.

The above results have been procured by the De Laval people in a series of experiments extending over a long period of years. New mechanical devices have been adapted, extending from the power plant to the most distant point on the pipeline that make the pulsations at all points certain, snappy and regular at all times.

This milking machine is but a part of the modern equipment at the Raymondale Farm, and makes this place one of ultimate development, as com-

pared with what was in existence in the far distant past. When one visits such a farm and looks it over, it is apparent that it represents thousands of years of progress much of which, however, is really of recent origin.

### FILM ADVERTISESE SEPARATORS

The Renfrew Machinery Company, of Renfrew, Ontario, has just produced a photoplay to advertise the cream separator.

The play is a one-reel comedy, entitled "You Couldn't Separator," and according to reports it goes off with a bang and a slam.

There is a real story running through the picture advertisement full of fun and motion, and what is more important emphasizes the good qualities of the company's separator and truck scale, and gives a few points which will be helpful to dealers.

The closing scene shows Fred Gayton, a farmer in the story, driving past the dealer Benton's hardware store early one morning. Benton asks the farmer how his wife likes the new separator which he, Benton, had sold the farmer some weeks before, and the farmer replies, "You couldn't Separator." As Gayton drives away we see a sign tacked on the end of his wagon, which reads, "We use the Renfrew Separator."

### TO MANUFACTURE WASHING MACHINES

THE American Mfg. Co. has been incorporated at Dayton, O., with a capital stock of \$100,000 to manufacture washing machines. A. B. Hilton, Jr., is president and treasurer. The company has taken over the business of the Pasteur-Chamberlain Co.

### SEAMLESS REFRIGERATOR

THE "Paris" Seamless Refrigerator, manufactured by the Sanderson-Harold Co., Ltd., of Paris, Ont., is a new refrigerator made in two types. A top icer with ice chamber door opening on face of refrigerator and a side icer with either three or four doors. The manufacturers make the following claims; that special attention has been given to the wall construction, mineral wool being used as an insulator and proper air spaces allowed to insure perfect insulation. The principal feature is the new one-piece seamless porcelain lining. The provision chamber is a seamless tank, without crack or crevice, and it is stated, can be kept much cooler than refrigerators lined with sheets. It also can be kept clean much easier, as there are no cracks to harbor germs.

### ELECTRICITY ON FARM

IF the rate at which folks on the farm are buying electric light plants this year keeps up very long, it will not be very long before electric lights on the farm will be as common as they are in the larger villages and cities. There are very few things that bring so much comfort and satisfaction to home life on the farm as do electric lights. Lighting is not the whole thing, however, for scarcely less important is the use of electricity for operating small motors, as on vacuum cleaners, sewing machines, pumps, washing machines, cream separators, churns, etc., and for ironing, cooking, and many other uses. Electricity is just another one of those things that, like the tractor, truck and automobile, makes farm life and farm work more enjoyable and worth while for the entire family, and helps to keep the young folks on the farm.



# How do you contract for a Separator?

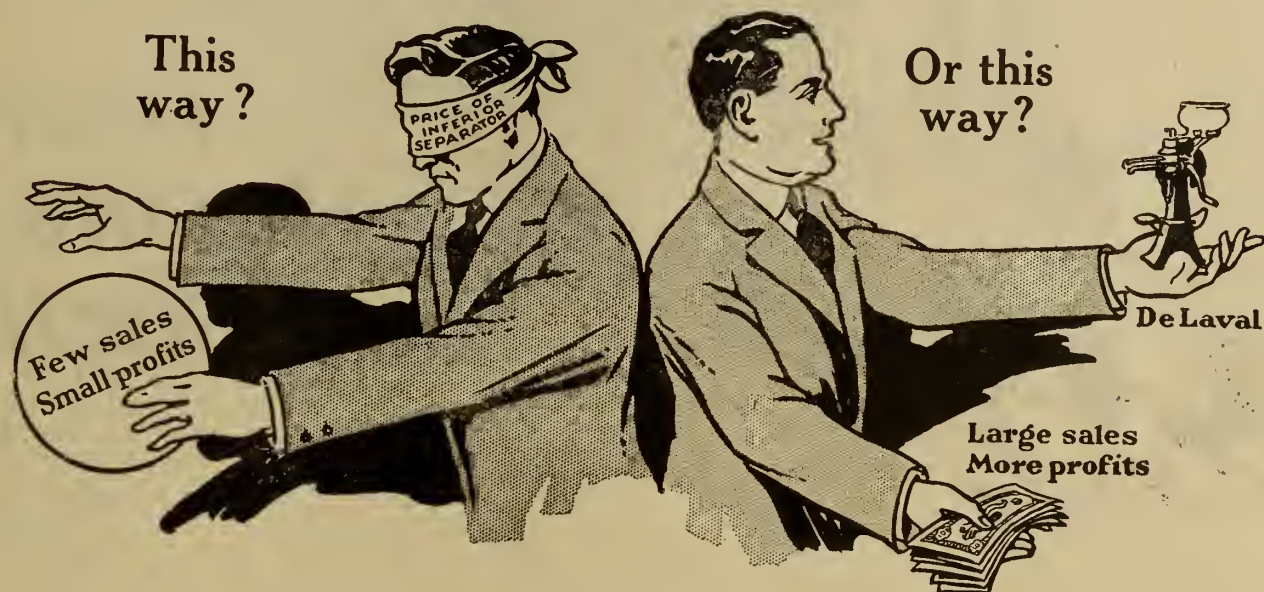

The most successful separator dealers are not blinded by the lure of low prices and "big" commissions. They have learned, either from observation or by experience, that it is easier to sell the De Laval, and that more of them can be sold.

There are several reasons for this: First, the De Laval is the best skimmer, is easiest to wash and lasts longest. Second, its manufacturers always render prompt and intelligent service. Third, the De Laval is the best known cream separator in the world—there are more of them in use than all other makes combined. Fourth, it is constantly advertised in farm papers and by direct-to-the-farm folders and letters.

There is no better time than right now to send in an application for a De Laval contract

**THE DE LAVAL COMPANY, LIMITED**

MONTREAL

PETERBORO

WINNIPEG

EDMONTON

VANCOUVER

50,000 Branches and Local Agencies the World Over





THE farmer's satisfaction with his tractor depends in a great measure on his fuel and repair bills. If these are low he is an enthusiastic booster and he uses his machine continually.

The amount of fuel used and the frequency of repairs depends, to a considerable extent, on the lubricating oil. If a poor lubricant, unsuited to the farmer's machine, is used, these costs are bound to be high.

A high-grade lubricant, such as Imperial Polarine Kerosene Tractor Oil, Imperial Polarine Kerosene Tractor Oil Extra Heavy, or Imperial Polarine Heavy, *assures low costs* on these items.

From these three tractor lubricants can be selected the right grade for any tractor. If the one grade, recommended by the Imperial Chart of Recommendations, is used exclusively, satisfaction is assured.

Three grades—Three sizes—Sell by the Chart.

Have you sufficient stocks?

**IMPERIAL OIL LIMITED**  
 Power ~ Heat ~ Light ~ Lubrication  
 Branches in all Cities



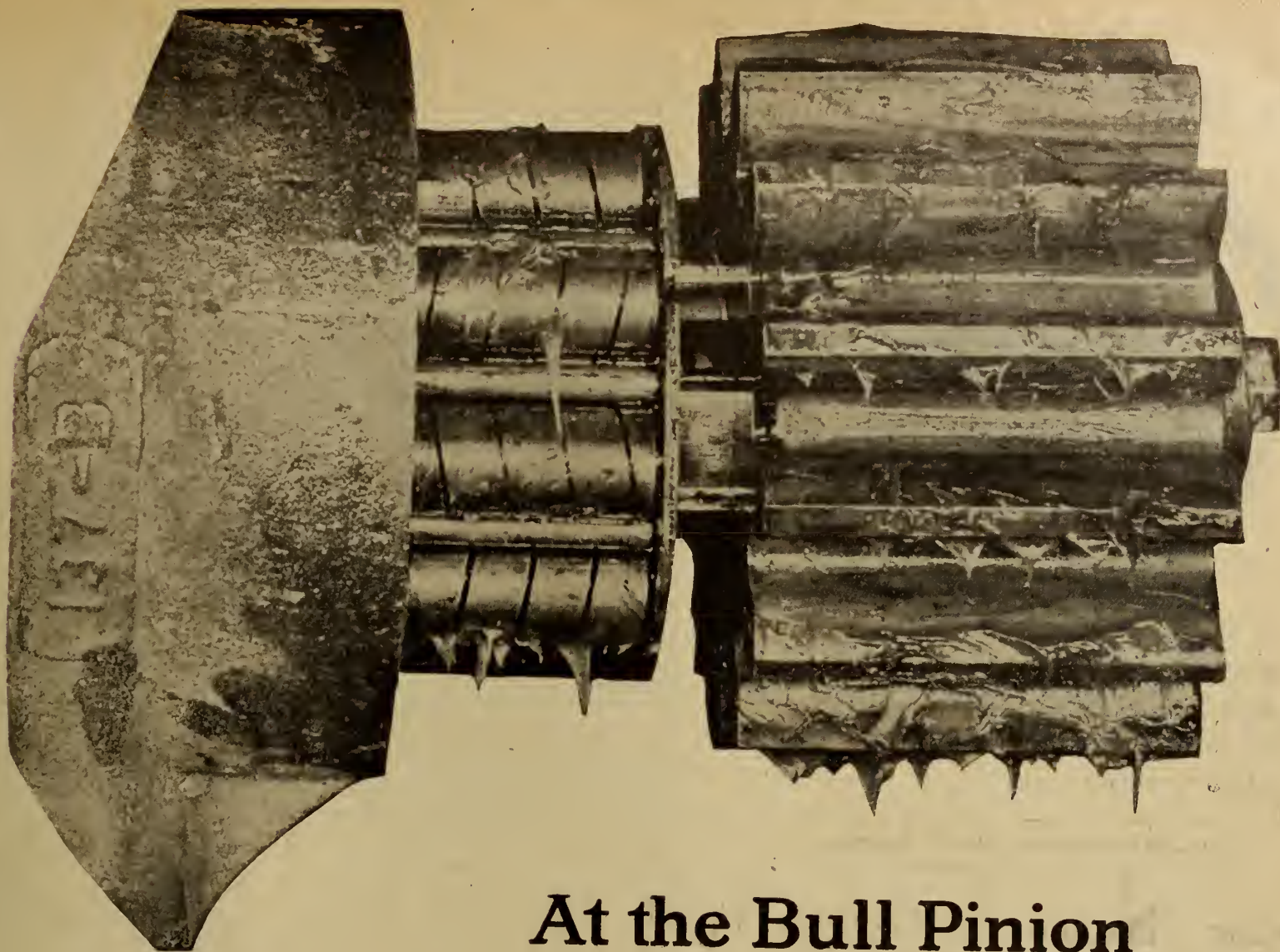

## At the Bull Pinion

**T**HE bull pinion bearing carries the heaviest load of any bearing in the tractor.

**T**HIS is a reproduction of an unretouched photograph of the bull pinion gear and its Hyatt Bearing. This gear and bearing have had over two seasons' hard field work in a tractor.

Micrometer measurements show that there is less than 2/1000 of an inch wear on the bearing—less than the thickness of the paper this ad is printed on.

This is one of thousands of proofs that Hyatt Bearings carry their loads permanently and are as durable as the shafts on which they operate.

That Hyatt Roller Bearings are built for this hard and continuous service is demonstrated by their successful use at this position in 90 per cent of all prominent makes of tractors.

At the bull pinion Hyatt Roller Bearings are a protection against wear and loss of power—they maintain true shaft alignment and proper mesh of gears—they insure uninterrupted service without adjustment.

**HYATT ROLLER BEARING COMPANY**

Tractor Bearings Division  
Chicago

Motor Bearings Division  
Detroit

Industrial Bearings Div.  
New York City

# HYATT

## ROLLER BEARINGS



# The Heart of Your Car

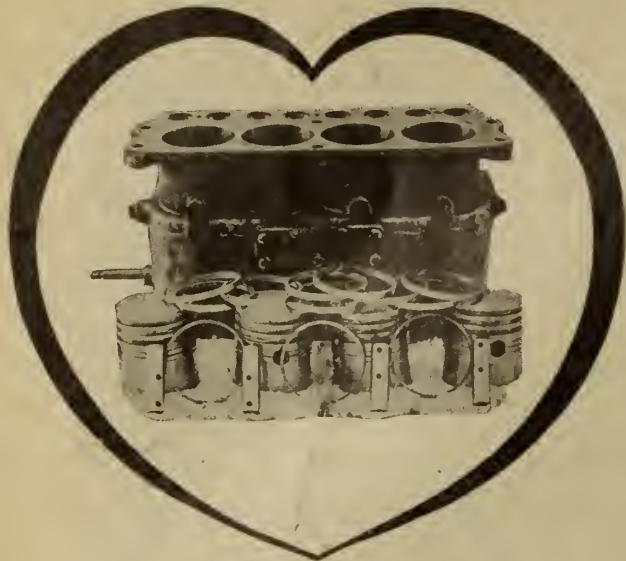

We regrind Cylinders, make Pistons, Rings and Pins, with special equipment adapted for this purpose. Also parts to order.

*We Do Oxy-Acetylene Welding*

**Advance Machine & Welding Co.**  
177F Canning Street, Montreal



# PERFEX

*The Perfect Radiator*

Perfix radiators for Fords are a quality product embodying features that cannot be had in other radiators.

A patented spring bracket suspension and a real radiator core of great efficiency.

*The last word in Radiator construction*

**Perfix Radiator Co., Racine, Wisconsin, U.S.A.**

P. A. C. McINTYRE & COMPANY  
311 Confederation Life Building, Winnipeg  
Direct Representatives for  
Manitoba, Saskatchewan, Alberta and British Columbia

## A NEW RESOURCE MAP OF CANADA

A "Map of the Dominion of Canada indicating natural resources, transportation and trade routes," scale 100 miles to the inch, has just been published by the Department of the Interior.

On this map varieties of mineral, agricultural and fishery resources, and the timber and fur in general are printed in red lettering in their proper locations. The sites of important water powers, developed and undeveloped, are indicated, and the lines of all railroads completed up to date are clearly defined.

The resources shown on the map extend from "whales," near Herschel Island in the Arctic, to "salt," at the southern toe of the Ontario peninsula, and from the "white whales" of Ungava Bay to the fruit lands near Victoria, B.C. An important inset contains 5 circular diagrams, showing the comparative contributions of each province to field crops, commercial timber, developed water power, fisheries and minerals. A sixth diagram displays the proportion of the total exports filled in 1918 by manufactures and by the five great classes of natural resources severally.

The thorough reliability of this map is shown by the caution which ignores probabilities, however promising. The trader, investor, manufacturer, and economic student will read the map as an open book; its appearance is timely when demand is abnormal and enlarged production a necessity.

The map can be obtained free of cost on application to the superintendent, Natural Resources Intelligence Branch, Department of the Interior, Ottawa.

## I. H. C. ANNUAL REPORT

THE Harvester Company's annual report for 1919, made public recently, shows gross sales of 212,700,000, somewhat greater than 1918, while net profits were somewhat less than last year. Before deducting war losses in Europe charged to 1919 earnings, the percentage of earnings to capital invested is 9½ per cent.; after reduction, 6 per cent.

This comparatively satisfactory showing is attributed to the agricultural prosperity of the United States and Canada, which offsets in some degree serious obstacles to European trade and unsettled manufacturing conditions at home. Unusually good collections in those countries permitted the company to anticipate payment of \$10,000,000 of obligations maturing in 1921. The only liabilities shown by the balance sheet are for current accounts payable.

European war losses have now been completely written off out of reserves established for that purpose and from current earnings during the last five years. The only investment in Russia and Germany now standing on the books consists of the plants and inventories of the factories in those countries, valued at \$6,850,000. Late advices state that the plant near Moscow is still in operation and is one of the few important concerns in Russia that have not been nationalized.

The factory near Lille, France, has been re-equipped, after being dismantled during four years of German military occupancy.

"In striving to rebuild its foreign business," the report says, "the company finds much evidence to support the position that, wholly apart from sentiment and merely as a matter of self-interest, America cannot afford to stand aloof while Europe struggles with the tremendous task of industrial and economic rehabilitation.

"Realizing this, the company is doing all in its power to aid the revival of agriculture in Europe. In this effort it has received cordial co-operation from the United States War Finance Corporation, which recently authorized a loan of several millions to the company to be used in financing foreign purchases of American farm implements."

Farm labor scarcity and higher cost, the report says, point to a distinct danger of falling off in food production, unless man-power in agriculture can be much more fully supplemented by machine power. The company's experimental efforts are now being directed toward providing the farm of average size with a complete equipment of power-driven implements that one man can operate.

The company's agricultural extension department, which is not a sales agency, but a contribution to the general welfare, has, in seven years, conducted 17,000 meetings for better farming, and its charts and slides have been shown at 51,000 meetings. Eleven million persons attended these meetings, which covered all the states.

Reviewing the first year of operation under the Industrial Council plan, whereby the workers now have a definite voice with management in shaping all industrial relations policies, it is stated that the effect in the three severe strike tests of 1919 was to bring about early resumption of work. "The plan has done much," says the report, "to foster the spirit of co-operation and has brought the employees and the management into a more intimate relation of mutual understanding and confidence."

The works councils have also helped to quicken interest in the Harvester savings and profit-sharing plan, now in its fifth year. At the end of 1919 there were 24,635 subscribers for certificates totalling \$8,391,000. Four thousand employees have become stockholders under this plan.

## CUSHION FOR TRACTOR SEAT

SOME drivers fail to appreciate the hard seat provided for their use and like to use some form of cushion. But usually a grain sack or two is the usual result of such desire. An occasional cushion, however, may be found in use but covered with dirt, grease, and rain strains until a respectable dog would look sidewise at it before going to sleep upon it.

Good cushions may be provided for truck and automobile use, and even for the tractor seat, by making the cushion tick of good oilcloth, which will turn water. Then, if desired for the automobile, a slip cover may be applied to the cushion, which may be removed for washing.

A good filling for tractor cushions will be found in ordinary cotton batting cut into small pieces or squares, or in removing the old cotton filling from a cushion and cutting up into small pieces also. Treat the cotton before placing it in the cushion again by getting the women folk to place the pieces of cotton in a big baking pan and then put in the stove oven to bake for half an hour, the fire being as hot as possible but yet not scorch the cotton. When they bring that cotton back to you it will be a lot of nice fluffy balls, as soft as feathers, and will make a good cushion. The cotton may be thus renovated several times as the cushion becomes hard and lumpy. A good cushion seat on a tractor saves the body the sharper jolts and strains and makes tractor operating less tiresome.

## MARITIME

MONCTON, N. S.—E. Givan, dealer in McLaughlin and Studebaker cars, is moving into a fine new show room.

TRURO, N. S.—Messrs. McLean and Fulton, tire repairers, are installing a large Bowser gasoline selling outfit.

LONDONDERRY, N. S.—L. R. Smith has secured the agency for the Maxwell automobile in Londonderry and Colchester county.

RICHMOND.—Messrs. Weir and D'Almaine have opened a new garage opposite the G. T. R. station. They handle Overland cars, Cleveland tractors and Harley Davidson motorcycles.



# A Plug Ripe From Hard Experience

*A Good Many Spark Plugs Sell in a More or Less Desultory Way Without Making any Noteworthy Records*

The Joly Spark Plugs—Over 5,000,000 of them stood firm in perfect service on every allied combat airplane during the four years of grilling war work.

And now we have acquired the American and Canadian rights to manufacture the Joly Spark Plug. We are in full production in our modernly equipped plant at Paterson, New Jersey.

You in the trade have been looking for a plug that would send a man away satisfied—and keep him satisfied—and bring him back, not for a more satisfactory replacement, but for “another of the same kind.”

Here it is—the thoroughly tested Joly Spark Plug—the one with longest record of super-endurance against the high compression and sustained speed of the plug-killing airplane motor.

This is the plug that is making the same tremendous records on American truck, tractor, passenger car, marine, gasoline and airplane engines.

In this splendid creation of design, material and careful construction lies your solution of the long-time question—

“Where can I get a spark plug line that will make, hold and increase my plug business?”

A plug such as this, with a performance record never equalled, is worth your consideration.

*The basic points of design briefly noted have made the Joly Spark Plug a creation of endurance and faultless service such as has never before been offered to the motoring public through the trade.*

Our acquisition of this impressive business, with its wonderful facilities for production now operative here, marks a new era in American spark plug development.

An agency franchise for the Joly line will lead to immediate and rapid development of your spark plug business. “Records count” and we offer you a four year old brutally tested plug with millions of super-records of endurance to its credit.

**IMPORTANT**—Do not tie yourself up on any spark plug contract until you have investigated the Joly Spark Plug and the sales plans back of it.

We want your inquiries.

List Price, \$2.00

**Lyons Ignition Company**

215-219 Fourth Ave.

New York, N. Y.

Export Dept.: Aggressive Agency Company

35 Notre Dame East  
1 Madison Ave.

Montreal  
New York, N. Y.

**“JOLY”**  
(PRONOUNCED “JO-LEE”)  
**SPARK PLUG**

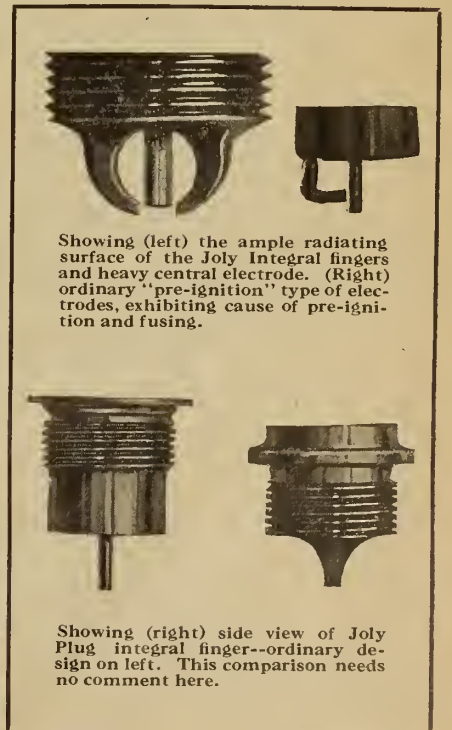

Showing (left) the ample radiating surface of the Joly Integral fingers and heavy central electrode. (Right) ordinary “pre-ignition” type of electrodes, exhibiting cause of pre-ignition and fusing.

Showing (right) side view of Joly Plug integral finger--ordinary design on left. This comparison needs no comment here.





# Automotive Accessories and Implement Equipment

## BELT-DRIVEN CHARGING SET

THE small garage is now able to obtain a satisfactory battery charging set for use from an engine or line shaft that is normally used for furnishing power for a lathe and other shop tools.

This set has been developed by the Northern Electric Company and consists of a 40-volt generator, having a capacity of 11 amperes, and a panel board equipped with switch, ammeter and rheostat. The plant will charge any number of 6-volt batteries from 1 to 10, and will undoubtedly prove very popular with the garages where the number of batteries to be charged is very limited, and the cost of installing a large battery charging set is prohibitive. The makers say this type of set also has the advantage that it can be used in towns where electricity for operating a standard charging set is not available. Some of the larger garages or battery service stations will also find it valuable as an accessory to the main set.

Manufactured by the Northern Electric Co., Ltd., 121 Shearer street, Montreal, Que.

## AMBU TEST BENCH

THIS test bench is designed for making every practical test on all types of starting, lighting and ignition apparatus. The makers say starting motors, generators, magnetos, cutouts, etc., may be tested under actual operating conditions. The outfit is complete in itself. It is compact and convenient and simple in operation. It consists of the bench proper, upon which is mounted the panel and other apparatus. A special three-way vise is provided, which holds any generator, motor, or magneto, while under test. The vise will also clamp any size or shape machine absolutely rigid in any position. It is movable in all directions, and because of its flexibility, the makers say, perfect alignment is assured.

The driving mechanism is mounted conveniently on the bench so that all speed changes are easily regulated. These changes are made by means of a friction wheel and disk. Variations in speed, in either direction, can be made from 100 r.p.m. to 4,000 r.p.m. A tight and a loose pulley are mounted on the drive shaft so that the machine may be driven from the shop line shaft, individual motor drive, or any other source of constant power.

The pressure of the friction wheel on the disk can be varied so as to eliminate slipping under conditions of high speed or heavy loads. All speed changes are smooth and uniform. Speed is indicated by a tachometer connected by a flexible shaft to the driving gear shaft.

The motor torque measuring device is so designed as to give the turning power of the starting motor direct in foot-pounds. A scale is provided for this purpose. The starting current is registered on the ammeter.

Not only can performance tests be made on the electrical units, but if the units fail to function properly, the exact cause of the failure can be determined.

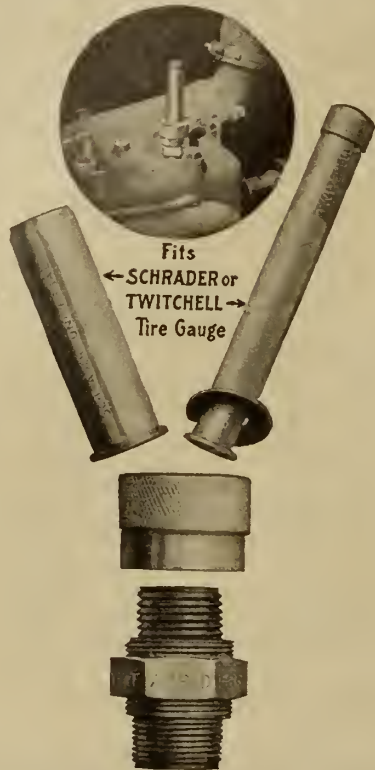

Duplex Compression Tester.

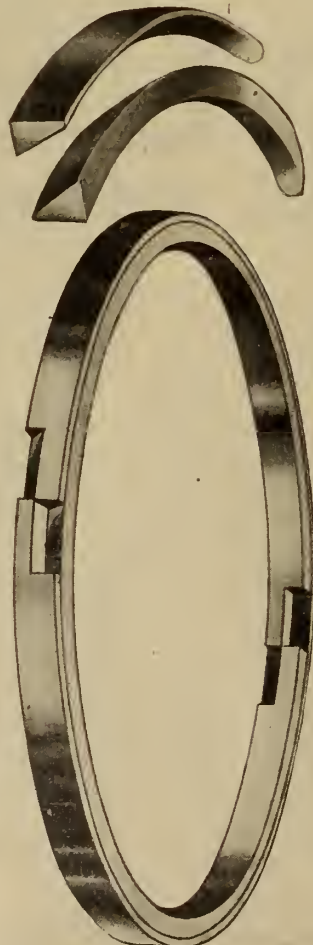

Excellence Piston Ring

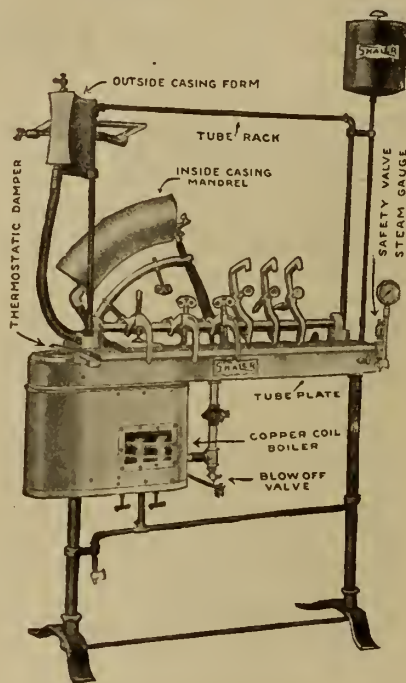

Steam Vulcanizer.



Ambu Test Bench

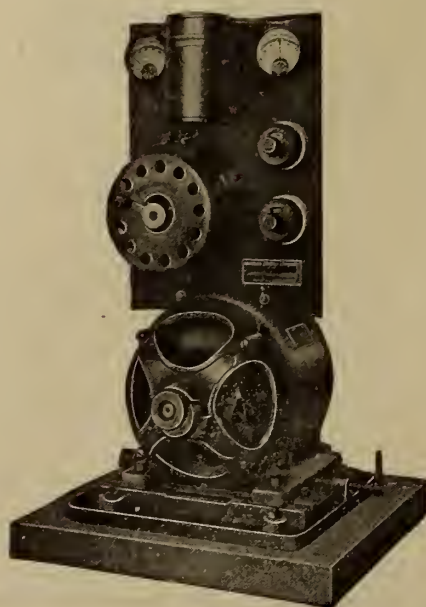

Northern Electric Charging Set

It is manufactured by the American Bureau of Engineering, Inc., 1601-03 South Michigan Avenue, Chicago, Ill.

## DUPLEX COMPRESSION TESTER

CASEY HUDSON COMPANY, 357-61 E. Ohio St., Chicago, makers of Liberty Spark Plugs, have brought out a new accessory for testing cylinder compression. The Duplex Cylinder Compression Tester, as it is called, is made to fit any cylinder using a half inch or seven-eighths spark plug. It is used with a Schrader or Twitchell Tire gauge. By taking out the spark plug and inserting the tester, and turning the motor by hand with a swinging stroke the compression is registered. This test, the makers say, can be quickly made of all the cylinders, and the weak cylinder, if there is one, instantly detected. The experienced mechanic or motorwise driver, can find out through the use of the tester if valves need regrinding, if piston rings do not fit tight, if gaskets leak compression. He can often find the cause of trouble that ordinarily would be detected only by tearing down the engine.

## STEAM VULCANIZER

THIS vulcanizer, it is claimed, handles every kind of tube and casing repair. Six tubes, the makers say, are mended as quickly as one on the machine surface of the tube-plate. This machine is also furnished with attachments which will permit two casings to be repaired at the same time and owing to the peculiar design of the mould for repairing casings, the moulds will handle tires from three to five inches perfectly. All sized tires can thus be handled without the necessity of having different moulds for each size. This applies both to smooth tread and non-skid tires.

The heating apparatus has a copper coil boiler arranged in such a way that while steam is being raised initially, the flame of the burner blaze is directly on the boiler. As soon as the temperature of vulcanizing is reached, the thermostatic damper automatically shuts parts of the flame into an auxiliary flue so that temperature control is accomplished without choking the flame and producing an unpleasant vapor of partly burned fuel. It is manufactured by the C. A. Shaler Company, Waupun, Wisconsin, U.S.A.

## EXCELLENCE PISTON RING

THIS piston ring, it is claimed, has ruled off all the troubles which the motorists have experienced heretofore. It is made in Canada and distributed by Lamontagne, Limited, Montreal, Winnipeg and Quebec, who say the great advantage of the Excellence ring is that it prevents oil from overflowing the surface of the piston and carbonize or dirt the spark plug, thus ensuring a perfect compression.

The ring is made in two parts, which by action on one another fill the piston groove perfectly and keep very tight on the cylinder wall, allowing, however, the required quantity of oil, AND NO MORE, to pass for the soft working and long-standing of the piston. The Excellence ring is made from high-grade gray cast iron which combines smoothness with strength.



# Allis-Chalmers Tractors

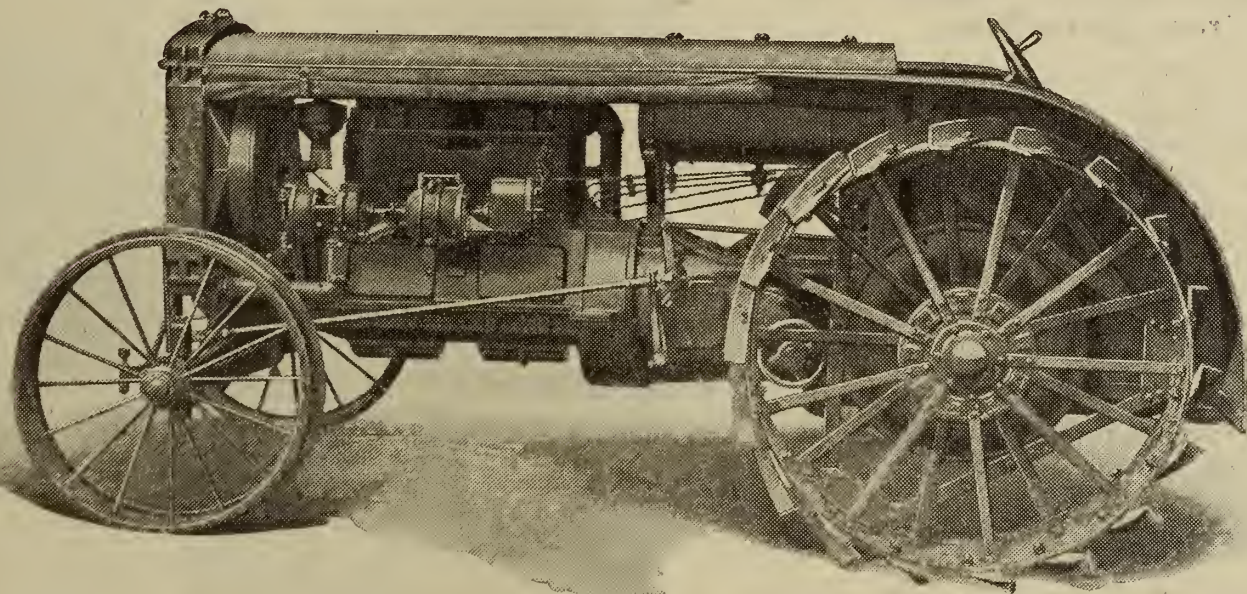

## Offer You the Best in Service and Construction

When you sell a tractor you are putting your reputation into the sale from which you expect to get profitable results.

Sell the right kind of tractor—not an experimental tractor, but a proved product built by a proved manufacturer.

For 65 years the Allis-Chalmers Manufacturing Company and the Canadian Allis-Chalmers, Limited, have been known throughout Canada as the largest manufacturers in the world making high-grade machinery. The Allis-Chalmers huge plants equipped with the most modern machinery are complete for quality production on a quantity basis.

Two models are offered to you—the 18-30, a big 4-plow tractor, will pull 4 plows and pull them fast. It has well over 30 H.P. for belt work. Its Allis-Chalmers 4-cylinder valve-in-head motor shows great economy on kerosene at all loads. All moving parts enclosed and dirt-proof. It has removable cylinder walls, roller bearings throughout, and all other modern features. An Allis-Chalmers product, from radiator to draw-bar, officially proven a leader in the tractor field. Weight, 6,150 lbs. And the 6-12 general purpose is a one-man tractor that may be used with any standard implement already on the farm requiring 4 horses or less.

FIGURE WHAT THIS MEANS TO YOU IN YOUR SALES

*If You Live in Alberta see us at the Edmonton and Calgary Spring Fairs*

**CANADIAN ALLIS-CHALMERS, LIMITED**  
Toronto.



\$4.00

\$4.00



Tool Locked in Position  
for Removing or Replacing Tire

## K.P. Universal Rim Tool

### The Easiest Way to Remove Tires from Split Rims

Fits all types of cross-cut demountable rims. Collapses a rim no matter how badly a tire may be stuck to it.

Holds rim collapsed while tire is being removed or replaced.

Forces the rim back on the tire again with the utmost ease and locks the rim in its original position; even in the case of tires which are undersized—an entirely exclusive and important feature.

The K.P. PRODUCTS COMPANY, Inc.  
250 West 54th Street, NEW YORK, N.Y.

Sold by

**Northern Electric Company**

LIMITED

Montreal Quebec Toronto Winnipeg Calgary Vancouver  
Halifax Ottawa London Regina Edmonton

## THE BEST BUMPERS OBTAINABLE



"KABEE"  
SPRING ARM CHANNEL  
BUMPER

"LYON"  
RESILIENT BAR  
BUMPER



DURABLE BRILLIANT FINISH  
PATENTED "HOOKBOLT" ATTACHMENT  
FITS 90% OF STANDARD CARS  
OBTAINABLE FROM JOBBERS & DEALERS  
CATALOGUE ON REQUEST

**KINZINGER BRUCE & CO. LTD.**  
NIAGARA FALLS, CANADA

SOLE MANUFACTURERS, UNDER  
LYON CANADIAN PATENTS.

### NEW HYATT BULLETIN

"THE DISK Harrow Hitch" is the title of a new bulletin issued by the Hyatt Roller Bearing Company and written by F. N. G. Kranich, Manager Implement Bearings Division.

The purpose of the Disk Harrow is explained, emphasizing the implement part that it plays in the preparation of seed beds. Adjustments are described and discussed in detail. It is pointed out that so many different factors affect the matter of draft that no definite rule holds good under all conditions. The angle at which the disks are set has the greatest influence. When the disks are set at too great an angle there is a skidding instead of a cutting action. Under such a condition it is necessary to add weight in order to get penetration. This further increases the draft. Working in wet or damp plowed ground also gives an increased draft. So does the lubrication and condition of the bearings. Directions are given for sharpening the disk blades and the necessity of keeping the implement in proper condition is stressed.

According to Mr. Kranich: "The value that a disk harrow, or any other implement, gives the farmer is in direct proportion to the attention that it receives. Good implements deserve good care. To get the maximum return for every dollar invested there must be a thorough understanding of their field operation, coupled with intelligent care."

### PLAN TO SELL HUNDRED TRACTORS IN 1920

FIVE years ago the gasoline tractor was practically unknown to the farmers of British Columbia.

During the great European War the tremendous demand for food products, the difficulty of getting labor, and the high cost of feed, turned the attention of the farmers of that province to the merits of the gasoline tractor as a source for farm power.

The increase in the use of this power by the farmers in British Columbia is well illustrated by the tractor sales made by the Pacific Tractor Company, Vancouver, Cle-trac tractor distributors for British Columbia. This company sold its first tractor in the spring of 1918. During that year missionary work of an intensive nature was carried out throughout the settled portions of the province and a few farmers and orchardists were convinced that the tractor was a means to aid greater production, but owing to the surface conditions of the average farm in that Western province, it took more than ordinary demonstration and salesmanship to convince him that a tractor would be of benefit to him.

That the Pacific Tractor Company have been successful is proved by the fact that this company has sold approximately eighty tractors, which are all operating successfully under all sorts of conditions in the Province of British Columbia.

The Pacific Tractor Company expect to place one hundred tractors during 1920, and by the way orders are coming in, their expectations are considered conservative.

### ANNUAL CONVENTION AT MOOSE JAW

THE executive of the Saskatchewan branch of the Retail Merchants' Association have now completed their arrangements for the annual general convention, which is to be held in the First Baptist Church, Moose Jaw, Sask., on Tuesday, Wednesday and Thursday, June 8, 9, and 10.

This convention, especially in view of the many important events that have taken place during the past year, having an important bearing upon retail merchandising, promises to be one of the most interesting conventions that has yet been held.

The convention will open at 9 o'clock on the morning of June 8, with the

registration of delegates and the distribution of badges. At 10 o'clock addresses of welcome will, it is anticipated, be given by the Mayor of Moose Jaw and the president of the Board of Trade and other public officials, followed by the president's address and the treasurer's and secretary's report.

This year will see a distinct change and a new departure in connection with the programme of the convention as compared with previous conventions in connection with the arrangements. Previous conventions have been taken up entirely by general discussions, at which the whole of the merchants were present.

This year it was considered that much time would be saved on the part of the delegates if sectional meetings were held, dealing with each particular branch of the retail trade, and with this idea in mind, the first afternoon of the convention, and the morning of the second day, will be taken up with sectional meetings of implement men, grocers, boot and shoe dealers, druggists, jewellers, automobile dealers, clothiers, music dealers, hardware, furniture, etc., each section of which will deal with matters of the most importance to their particular section.

At the meeting of the implement men, on the afternoon of June 8, it is expected that H. Davidson Pickett, of Moose Jaw (barrister), will explain various measures of legislation having direct bearing upon the retail implement trade.

In the evening of the same day, a general meeting will be held, when it is expected that Dr. J. G. Robertson, of the Department of Trade and Commerce, Ottawa, an authority on business conditions and the markets of the world, will give an address.

Another interesting feature is also being introduced to the convention of this year in the way of moving pictures, and it is possible that at the meeting of the first day, the McClary Manufacturing Company will show their moving pictures, illustrating the manufacture of enamelware, tinware, galvanized ware and most of the sheet metal lines sold by the average hardware store.

The morning of the third day will again take the form of the general convention, when resolutions from various branches of the association and important matters respecting the interests of retail merchants, will be brought forward, and it is anticipated that T. B. Patton, Income Tax Inspector of Regina, will give an address on the making-out of the income tax returns, and other phases of this important question to retail merchants.

The election of officers will subsequently take place, and it is announced that in the evening the delegates of the convention will be given a banquet by the merchants of Moose Jaw, who may be relied upon to make this social side of the convention a great success.

The members of the association throughout Saskatchewan are urged to set aside these dates in order that they may be able to attend this convention, and by their presence and every possible means, make it one of the greatest and most successful conventions that has yet been held for them.

### APPOINTED HAYNES DISTRIBUTOR

British and American Motors, Ltd., 77-85 Avenue Road, Toronto, successors to Wolseley Motors Limited, have acquired the exclusive selling rights for Haynes cars throughout the Province of Ontario, Canada, according to an announcement by Mr. S. M. How, General Sales Manager of The Haynes Automobile Company, Kokomo, Indiana, U. S. A.

The firm members of the British and American Motors, Ltd., are well known to the motoring public of Toronto. W. H. Gooderham, President of the company, who was a recent visitor at the Haynes factory, has outlined an extensive and aggressive sales and advertising campaign for the promotion of Haynes sales in Ontario.



# THE Baldwin Automatic Grease Cup

(Patented)

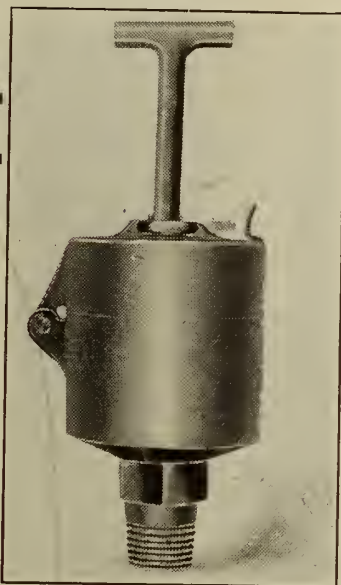
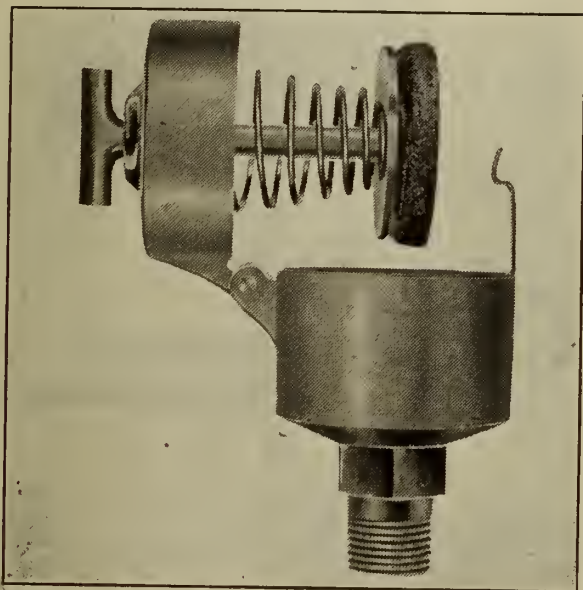

For Automobiles,  
Trucks, Tractors,  
and Stationary  
Engines.

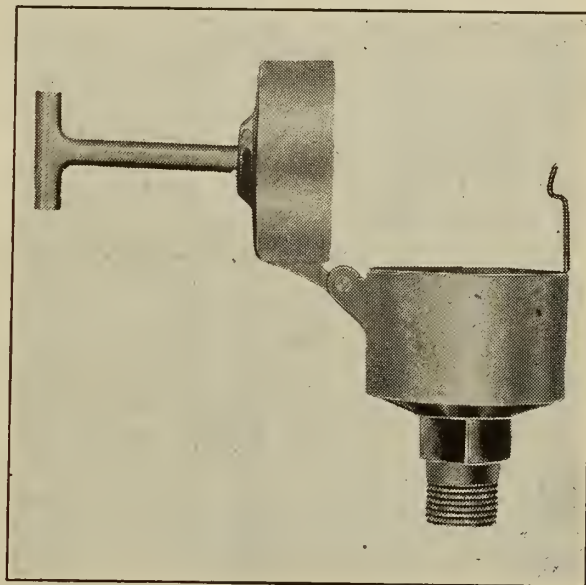

Do you ever stop to think what lubrication neglect means?

It means wear and tear on the most vital spot of a mechanism.

Baldwin Automatic Grease Cups are produced for a purpose—to help out the human element in all things mechanical where lubrication is required.

We don't say that, if a man fails to replenish the supply of lubricant, the cups will be like Aladdin's lamp; but we do claim that with the necessary lubricant these cups will continue to automatically feed until supply is depleted, thereby making a vital spot an efficient one.

Baldwin Automatic Grease Cups can be used on any moving machinery, automobiles, tractors, motor boats, stationary engines, turbines, steam engines and locomotives with equally good results.

Equip your machinery or product with Baldwin Automatic Grease Cups.

We are manufacturing these cups in brass and steel.

*Prices sent on request*

## The Specialties Co.

228 Craig St. West

Montreal, P.Q.



## Friends for Life—

**N**EXT time your customer says "socket wrench"—sell him a "HEXALL" set. The fact will stick in his mind that you put him next to a proposition that gave him 100% service and satisfaction. When admiring friends ask where he got it, he's sure to say—"Bill Smith sold me this 'HEXALL' set; you can always depend upon Bill to give you the right dope; good old scout is Bill." **TRY IT.**

*That's the tonic that builds business.* And it's because folks without number all over the country are continually asking "HEXALL" users "where they got it" that "HEXALL" Socket Wrenches to-day are eclipsing all former selling records. True, "HEXALL" is "there" in every sense of the word—in fact, we contend that they are *the best socket wrenches in the world.*

*Seven sets—a "HEXALL" for every need.* Fashioned with that scrupulous regard for perfection that makes it possible to place this "Guarantee of Faith" upon every "HEXALL" before it leaves the factory:

**"Break any Sedgley Wrench and We  
Repair it—No Charge"**

Handles are drop-forged; sockets made from bar steel on automatic machines; broached and case-hardened—with that rare skill that adapts steel to the particular purpose it is to serve.

**R. F. SEDGLEY, Inc. Est. 1897**

*Also Makers of "BABY" Hammerless Revolvers*  
2311-13-15 North 16th St., Philadelphia, Pa.

Canadian Distributors: Lamontagne, Limited, Montreal, Canada.  
Sole Agent: Harold F. Watson Co., 208 Coristine Bldg., Montreal, Canada.

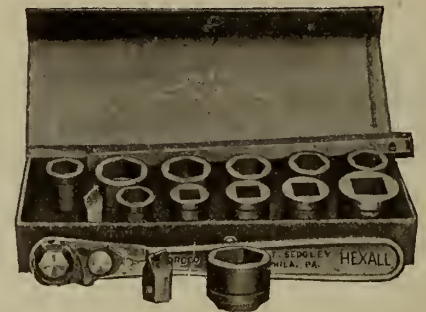

"HEXALL" Ratchet Socket Wrench  
No. 1—16 Pcs.



"HEXALL" Ratchet Socket Wrench  
No. 2—11 pcs.

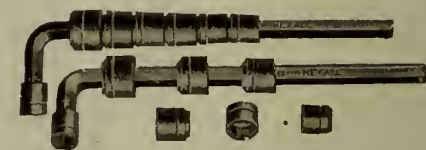

"HEXALL" Socket Wrench No. 5—  
8 Pcs.

## A New Canadian Stamping Plant



Pressed metal parts, light and medium weight stampings, card holders, washers, shims, clips, retainers, spacers, cover plates, shells, motor, axle, transmission and clutch stampings—We are at your service with quality and prompt deliveries on any of this work. Send for folder listing 1000 different sizes of washers—Also send us your blue prints and samples for estimates.



To insure convenience and prompt service to our Canadian customers, we have established a factory at Walkerville, Ontario.

The new plant is now ready to do business. It is strictly an independent factory, capable of taking care of any light and medium weight stamping needs you have—and capable, too, of producing the same quality of work which has maintained the reputation of Kales Stampings for 15 years.

**KALES STAMPING CO. LIMITED**  
61 Walker Road, Walkerville, Ontario

### Hindview

Auto Mirrors

Mirrors are required by law in Ontario. "Hindview" is a mirror that has been making good for hundreds of dealers and jobbers in Canada and the United States. Strictly a quality mirror—made for open and closed cars and trucks. Write for descriptive literature.

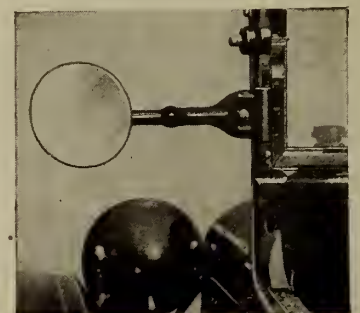



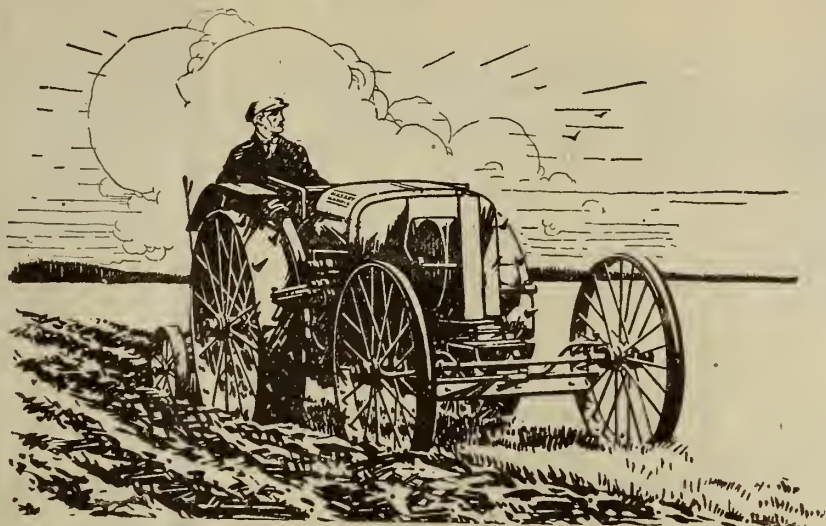

## The Embodiment of Strength

The strength of Hercules enabled him to perform wonders and it made him famous. To-day, as in olden times, people admire anyone or anything possessing unusual strength. That is one reason for the wide-spread popularity of the Massey-Harris Tractor, its strength is predominant.

Its very appearance proclaims the ability to do ordinary farm operations quickly and easily. To see it in operation is to verify your opinion of its goodness; while to stand on the platform and operate a Massey-Harris Tractor is to experience the delight of having under your control a giant of power and strength.

The materials used in the Massey-Harris Tractor have passed our laboratory's rigid tests, they have strength to carry heavy weight, bear jolts and jars, and to wear well in constant service. Critical experts examine each unit and only the perfect in strength and construction have a place in the Massey-Harris Tractor.

The Agent who handles the Massey-Harris Tractor handles an all-round-the-year line of implements built by the makers of high-grade farm implements for over seventy years. Applications for representation in vacant territories should be addressed to the Manager of the branch nearest you.

**MASSEY-HARRIS COMPANY, Limited**

Head Office - Toronto, Ont.

AGENCIES EVERYWHERE

WE GIVE

**“Quality and Service”**

IN

**TRACTOR and TRUCK  
STEEL CASTINGS**

**JOLIETTE STEEL CO., LIMITED**

Tel. Main 402  
9th Floor, Read Building  
Montreal, Que.

**JOLIETTE,  
P.Q.**

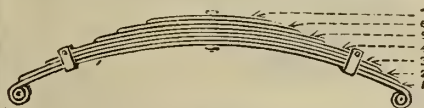

**AUTOMOBILE  
SPRINGS**

The Guelph Spring and  
Axle Co.

Guelph, - Ontario  
Manufacturers

**AUTO SPRINGS  
ALL KINDS  
HIGHEST QUALITY**

For repairing cracked water jackets, cylinder heads  
and split gas pipes, use

**ALUMALL METAL**

the greatest crack filler known. Thousands of garages  
using it now, with great satisfaction. \$6.00 a box.

Sold Exclusively by

Geo. W. Anstett, - McGee, Sask.

## BT Pulleys Are Best

BT Pulleys are the strongest and most reliable made. The frame is made of malleable iron and will not break. It extends below the centre axis, so the rope cannot get in at the side of the pulley.

No weight falls on the bolt. The weight falls on a large axle, which cannot turn and does not wear nor cut the sheave. BT Pulleys are made with iron or wood sheaves in all the regular sizes.

**Beatty Bros., Limited**

Fergus, Ont.  
Winnipeg  
Montreal  
Vancouver

London, Ont.  
Edmonton.  
St. John, N.B.  
London, England.

Hay



Cars





## Big Increases in Auto Mirror Sales

The enormous increase in the sales of "Hindview" Auto Mirrors in 1919 and 1920 proves conclusively that motorists now consider the Auto Mirror an indispensable aid to safe driving, rather than a mere fad.

Auto Mirrors are now required by law on all trucks in the Province of Ontario.

# Hindview AUTO MIRRORS

are substantially made—guaranteed to be free from defects, and absolutely waterproof. Clamps are large and firm; the Ball Joint—and exclusive "Hindview" feature,—allows instant and convenient adjustment. There is a "Hindview" for every type of motor car and truck.

Dealers handling the "Hindview" are making big profits.

May we send you literature ?

**KALES STAMPING COMPANY, LIMITED**  
61 Walker Road, WALKERVILLE, ONT.

Makers of Pressed Metal Parts, Washers, Light and Medium Weight Stampings

# Aikenhead's

"The Sign of Better Service"

## Burd Quick Seating Piston Rings



**Most Popular one piece Piston Ring**  
**Quick Seating Features of a Narrow Ring**  
**Wall Tension of a Wide Ring**  
**Seat in 45 minutes**

*Instantly approved by Mechanics and Motorists*

A "Seat" in perfect harmony with the cylinder walls is produced in about 45 minutes running. The central channel of the ring carries sufficient oil to prevent undue wear.

**Aikenhead Hardware Ltd.**  
Toronto - Canada

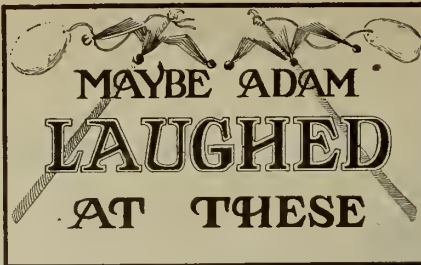

Motorist (arrested for speeding)—  
A fine morning isn't it, judge?  
Judge—It is. Ten dollars to be exact.—*Home Sector.* L

\* \* \*

"Got any mail for Mike Howe?" asked the stranger at the small town postoffice window.  
"No, nor anybody else's cow," retorted the indignant postmaster.

\* \* \*

"Where did you get these cigars?"  
"A friend of mine sent them up from Cuba."  
"Your friend certainly knows the ropes down there."—*The Siren.*

\* \* \*

Sub Editor—A correspondent wishes to know why they whitewash the inside of a hen-house.  
Editor—Tell him it's to keep the hens from picking the grain out of the wood.—*Boston Transcript.*

\* \* \*

"Children," said Teacher, "can any of you tell me what is the most dangerous part of an automobile?" Up went a hand, and Tommy (who walks to school) responded shrilly: "Yes'm, I can, it's the driver!"—*Insurance.*

\* \* \*

Jessie—"How do you like your new dress?"  
Bessie—"It falls just a little below my expectations."  
Jessie—"I noticed that, too. They are making them awfully short this year!"

\* \* \*

Four-year-old Charlotte was having trouble with her English, but she had entirely passed her difficulties on one point.  
"I see how it is now, mother," she said the other day. "Hens set and lay; and people sit and lie, don't they, mother?"—*Country Gentleman.*

\* \* \*

Jenkins and his best girl were motoring a considerable distance to see one of the last-round cup ties, and the margin of time was very short.  
With about twelve miles to go, he bade defiance to all police traps, and, turning to the girl of his heart, exclaimed:—We're going at fifty miles an hour. Are you brave, dear?"  
The girl, as she swallowed a quantity of dust, replied, with emotion: "Yes, dear; I'm full of grit!"—*London Tit-Bits.*

\* \* \*

Chug-Chug! Br-r! b-r-r! Honk! Honk! Gilligillug-gilligillug!  
The pedestrian paused at the intersection of two busy cross streets.  
He looked about. A motor-car was rushing at him from one direction, a motor-cycle from another, a steam truck was coming from behind, and a taxicab was speedily approaching.  
Zip-zip! Zing-glug!  
He looked up, and saw directly above him an air-ship in rapid descent.  
There was but one chance. He was standing upon a manhole cover. Quickly seizing it, he lifted the lid and jumped into the hole just in time to be run over by an underground train.  
—*London Tit-Bits.*

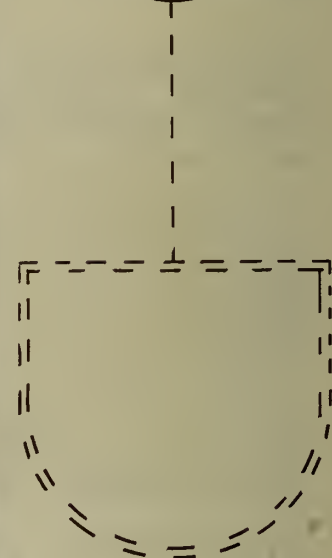
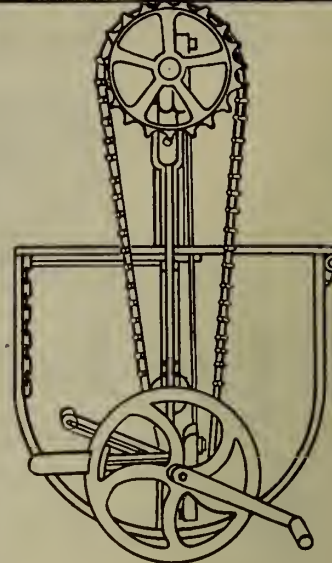
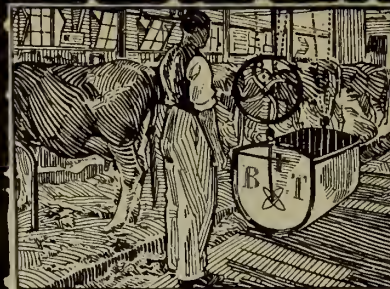

## Lift the Brake —the Bucket Drops

The BT Manure Carrier is the only one on which the bucket drops by its own weight. It need only be windlassed up. To lower it, just lift the brake and the bucket drops—no labor is required.

This is possible because there are no complicated worm gears to cause friction and waste power.

Not only does the BT Bucket drop by its own weight. It can be windlassed up more easily, when filled with 500 to 800 pounds of litter, than other carriers when empty.

Write our nearest branch for catalogue and all particulars.

## Beatty Bros., Limited

Fergus, Ont. London, Ont.  
Winnipeg Edmonton.  
Montreal St. John, N.E.  
Vancouver London, Eng.

Manure  Carriers



# The World's Most Popular Spark Plug

The unfailing dependability of Champion quality construction has justified every claim for it—today it is the world's most popular spark plug.

Our "3450" insulators, and our patented copper asbestos, compression-proof gaskets, form a combination that insures for Champions a dependability far in excess of ignition service requirements.

 **Champion**

## Dependable Spark Plugs

with "3450" insulators are practically indestructible—and there's a special plug for every type of motor or gasoline engine.

Making a feature of Champion dependability is bringing big business to dealers in automotive equipment.

Why not get in line for your share of this business by tying your store to our advertising.

Have a full line of Champions in stock so you will be able to supply all demands.

*Order from your jobber today*

**Champion Spark Plug Company of Canada, Limited**  
**Windsor - Ontario**

*Largest factory in Canada making spark plugs exclusively and the only factory making "Champions"*



**Champion "X"**

A15— $\frac{1}{2}$  inch  
Price - 90c

Adopted by the Ford Motor Co. as standard equipment on Ford cars since 1911.



# POWER, LOW UPKEEP, LONG LIFE

BUILT IN CANADA



Veteran Trucks are designed to stand up under difficult conditions. Use your Veteran every working day in the year, fine weather or foul, good roads or bad.

Easy to run and keep running—little attention required.

Immediate delivery from stock

We Have A Good Proposition For Live Dealers

EASTERN CANADA MOTOR TRUCK CO., LTD.  
HULL, - QUE.



## Profits in "CARBON CURE"

We have been telling the public, through wide-spread advertising, of the great medicine for carbon troubles in gasoline engines.

It is not "just another carbon remover"—

# D-B CARBON REMOVER

works without damage to the engine, and positively removes all carbon in thirty minutes without laying up, and does not cut compression.

It is just what the motorist wants—will he find it in your stock? There is good money in it. Investigate our dealer's proposition.

### Auto Jack Says:

It's funny how a man who uses a tooth brush twice daily to preserve his teeth should begrudge his engine a weekly dose of D-B—the engine's dentifrice.

The Dustbane Mfg. Co.

Limited

Ottawa, Ont.

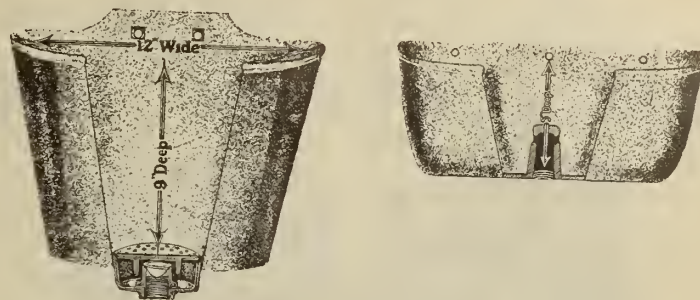

## This vs. That

To give satisfaction, a Water Bowl must be deep. The BT Bowl is 9 inches deep, inside.

The 9 inches of fall from the tank means a quick inflow. Shallow bowls give only about 5 inches of fall; naturally the inflow is sluggish.

It's hard to instal

shallow bowls. Unless set dead level there's only two or three inches in the end bowls.

Cows splash water out of shallow bowls. With BT Bowls you can keep the water about 3 inches from the top and prevent this.

With a shallow bowl there'd be nothing left to drink.

### Beatty Bros. Limited

Fergus, Ont.  
Montreal  
Vancouver

London, Ont.  
St. John, N.B.

Winnipeg  
Edmonton  
London, England.

'Tis better to  
give more  
than to give  
less

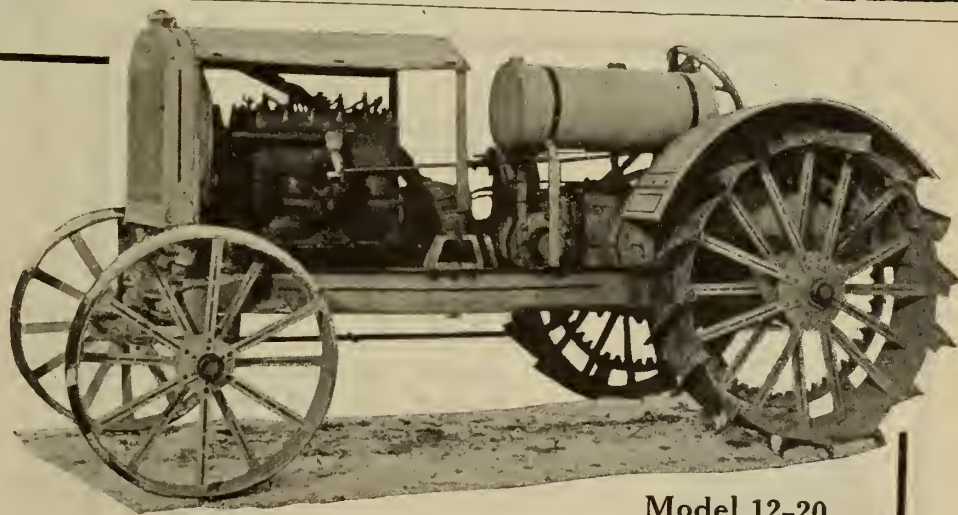

Model 12-20

## The "ESSEX" Tractor

Naturally, your farmer customer is going to feel mighty friendly towards you and towards his "Essex" Tractor when he discovers that in actual operation his "Essex" delivers more power in emergency than you claimed it would.

Both the Model 12-20 and the Model 15-30 will stand up and deliver, day in and day out, the power they are rated to give, and still have reserve for emergency.

You will find it most profitable and pleasant to sell a tractor that plays safe with your reputation as well as its own. We have an interesting dealer proposition that we would like to send you. Write for it to-day.

Essex Tractor Company, Limited,

Essex, Ontario



MADE IN CANADA  
*Westco*

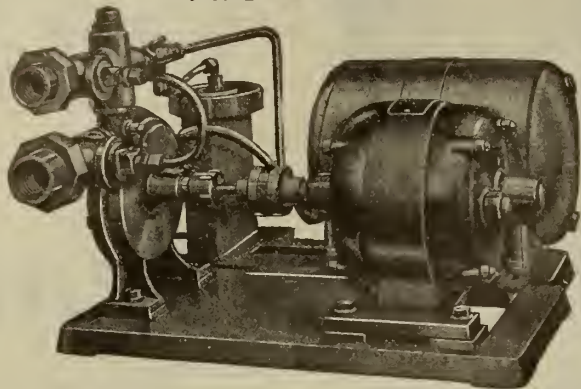

## A Water System Without A Tank

FOR OPERATION OFF HYDRO OR FARM LIGHT PLANT

Here you have none of the installation troubles and high expense of the old style gravity systems with their attic tanks, nor of the equally troublesome pneumatic tank systems at present so widely used. You, Mr. Dealer, know what they cost you in Service and Wasted Time, even after they are installed.

The PUMP in the "WESTCO" Tankless Water System has ONLY ONE MOVING PART

Think what this means in Saved Service Expense and Satisfied Customers.

IT IS COMPLETELY AUTOMATIC IN ITS OPERATION

Opening any faucet starts pump immediately. Close the faucet and pump stops. It comes completely assembled, as shown in the cut. A man can carry it. It pumps from 300 to 500 gallons per hour against any pressure required up to 75 lbs. (175 ft. head).

Is Your Territory Still Open? Literature and Full Particulars on Request.

Westco Pumps, Ltd., 707 Yonge St., Toronto

### BALDWIN GREASE CUPS

THE need of effective lubrication to bearings and all surfaces subjected to friction, has been, and probably always will be, an outstanding factor in engineering problems. The varied conditions under which many mechanisms are required to operate makes it imperative that ample facilities be provided for proper lubrication, in order to avoid the inconvenience, and even destruction, that frequently follows from insufficient foresight in this connection.

The Baldwin Grease Cup is a new design of grease cup which is automatic in its action, for when the cup is once filled and pressure applied, the feeding process is constantly maintained until all the grease has been delivered to the bearing. These grease cups are made in a variety of sizes and designs to suit any desired purpose or condition, the action of the automatic principle being identical in every instance. All parts are interchangeable on each size of cup, so that separate pieces are available for any replacements. The cup may be inverted or located in any position without affecting its efficiency. These cups are adapted to locomotives, marine, gas or stationary engines, and all mechanical equipment where grease cups are used. They are made and sold in Canada by the Edward A. Robinson Co., 228 Craig St. W., Montreal.



SAYS THE MASTER MECHANIC: The Greb Automatic Grip Puller is a One-Man Puller—Quick-acting, strong and simple in the extreme. May be locked in any desired position. A combination of two or three arms. Heavy Duty Size capacity 1" to 1 1/2". Junior Size capacity 1" to 7". Two sets of jaws furnished with each size.

TEN DAYS' TRIAL.—If you dealer or jobber does not have them we will send you one. Try it ten days. If not satisfactory, return to us and we will refund your money. We also make the GREB RIM TOOL.

THE GREB COMPANY, 319 State St., BOSTON

## Sell Holton Hood Clips for Chevrolets



They stop hood rattles. They do away with the troublesome thumb screw. They sell at sight. Every Chevrolet owner is a prospect.

Quickly adjusted without the use of tools. Engine hood can be opened and closed in a second or two. Holton Hood Clips Never Slip. A real spring clip.

Your Jobber Stocks Them

Patented and Manufactured by  
The Holton Hood Clip Co.  
WINDSOR, ONTARIO



## The Plug with the HOTTER SPARK

The ball point of the "M & S" plug creates a larger and hotter spark, causing more complete combustion. This hot spark will give your car new life and more power.

The three-in-one terminal is adapted to any style ignition wiring. The high-grade chemically glazed porcelains are interchangeable — one porcelain fits all plugs.

DEALERS--The "M & S" plug is standard equipment on the new Overland "4". Ask your jobber for them.

Machine & Stamping Co., Ltd.

1209 King Street West  
TORONTO  
Commercial Dept.

Russell Motor Car Co., Limited

### Models

- 500—1/2" Standard
- 501—7/8" Standard
- 502—7/8" Long
- 503—7/8" Long with Chevrolet Terminal
- 506—1/2" Long
- 504—Regular Porcelain
- 505—Chevrolet Porcelain

## 18 H.P. Drawbar 36 H-P Belt

Goes through the soft spots.  
Right size for general purpose work.  
A high grade, economical tractor.  
Yields are increased by its use.

Traction always positive. 54-in. drum.  
Rolls the land ahead of the plows.  
A direct drive to the rear.  
Contains no bevel gears.  
Turns easily in small radius.  
Operates a 28-in. or 30-in. thresher.  
Reduces packing of the soil.

Write for detailed information regarding territory for Aggressive Agents

GRAY TRACTOR CO. OF CANADA, LIMITED  
308, Electric Railway Chambers, WINNIPEG, MAN.

Western Distributors:  
Norton & Lief Co., Ltd. C. Waring & Co., The Tractor Co., Ltd.,  
Calgary, Alta. Moose Jaw, Sask. Saskatoon, Sask.  
The Hub Garage, Yorkton, Sask.



# Glaring Headlight Law to be Enforced This Year

## LEGALITE

FOR SEEING THINGS AT NIGHT

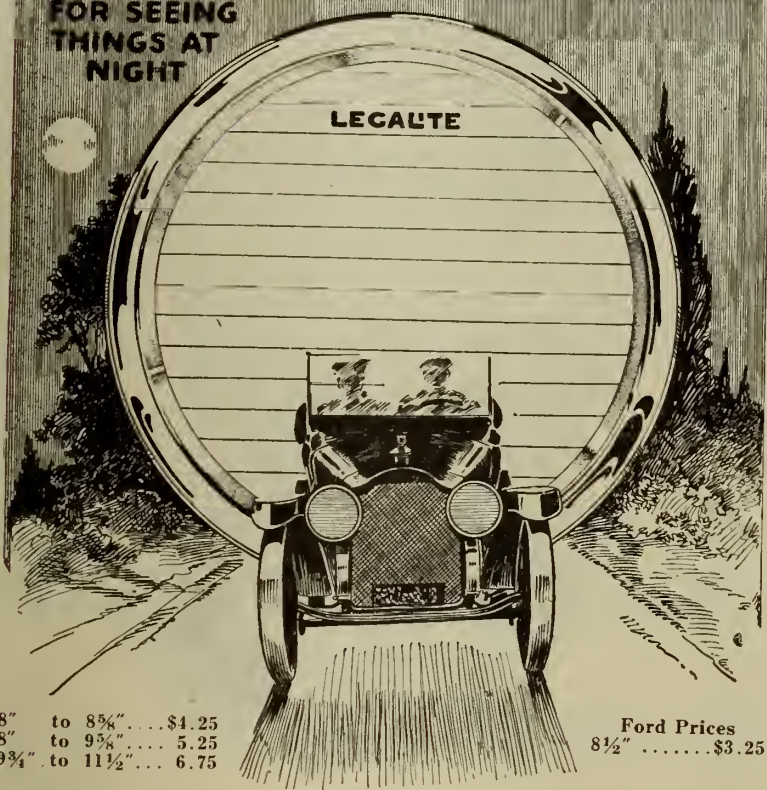

8" to 8 3/4" . . . \$1.25  
8" to 9 3/4" . . . 5.25  
9 3/4" to 11 1/2" . . . 6.75

Ford Prices  
8 1/2" . . . . . \$3.25

This law which has been on the statute for several years is at last to become effective. Within 60 days after the Ontario House prorogues the law will be enforced.

### Equip Your Car With Legalites Now

And you will be complying with all laws. You will also enjoy greater motor safety and comfort.

For Legalite Lenses give more light and throw all of it where it is needed—on the ground and never more than 42 ins. above it—with absolutely no glare.

**Dealers:** Every car owner in your vicinity is a prospect for Legalite Lenses. Get your share of this business by putting in your stock now. Write for special wholesale proposition

Exclusive Canadian Distributors

**HYSLOP BROTHERS, LIMITED**  
TORONTO

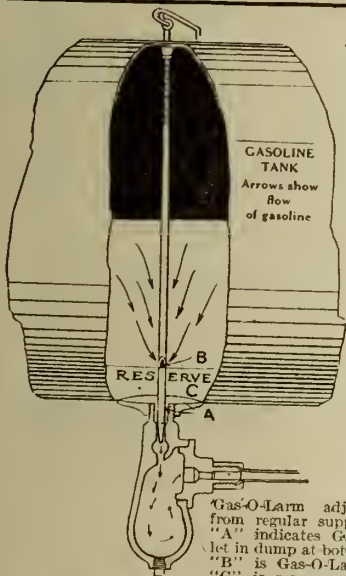

### Gas-O-Larm—The Watch-Dog in the Tank

With a Gas-O-Larm installed in the tank your Ford or Chevrolet owner goes anywhere and everywhere without a disturbing thought on his gas supply. When the supply gets down to one gallon, Gas-O-Larm gives fair warning by shutting it completely off. Then Mr. Owner opens his "reserve" and toots away to the nearest gas station to refill.

#### Every Ford and Chevrolet Owner will want one

As soon as you commence to tell about Gas-O-Larm. The price, \$2.00, is a strong factor for sales. There is not an owner on your list that would not gladly rid himself of his old measuring stick and his gas worries at this price. Only takes a minute to install, and anyone can do it.

Write to-day, for our splendid dealer proposition. It's a money-maker.

**E. & C. AUTOMOTIVE IMPORT CO.**

120 King Street East

TORONTO

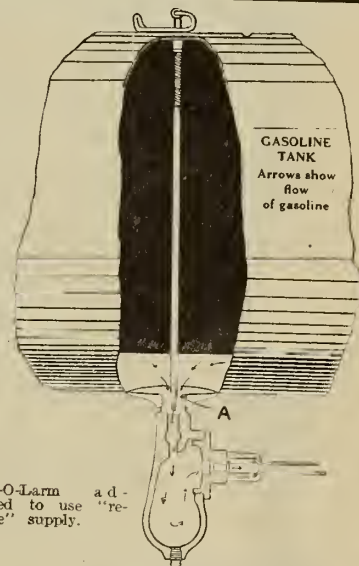

### KEEP POSTED

Through a regular service of

## Press Clippings

We gather information from all publications in Canada and the United States and can place on your desk news of changes, enlargements, fires, assignments, new advertising, or developments that affect your business. Write to

**CANADIAN PRESS CLIPPING SERVICE**

143-153 University Avenue, TORONTO

### REPAIRED by the MANUFACTURER

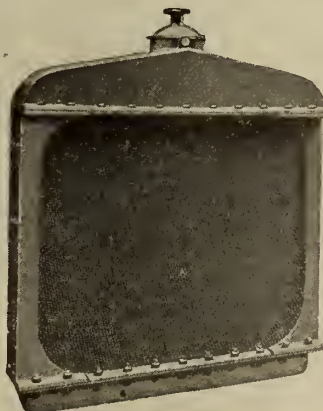

We maintain a thoroughly equipped Repair Department. Send radiator (any make) by freight or express, write instructions and we promise immediate and satisfactory results.

Repairs and shipment made within 24 hours (or earlier) after we have received radiator and instructions to proceed.

**McCORD Mfg. Co., Walkerville, Ont.**



# CHASE TRACTOR

## Built Without— Differential Gears

Pulls Itself Out of Trouble—Uses Less Kerosene—Avoids Tie-Ups and Repairs

Because the Chase has no differential gears it avoids many frequent causes of tractor trouble.

Understand how differential gears affect the operation of a tractor and the superiority of the simple design of the Chase is clear.

Tractors with differential gears can do their best work only on a straightaway pull on level land. The moment one wheel meets an obstacle, the differential throws all the power into the other wheel, so, quite often you see such a tractor with one rear wheel dead and the other spinning. That happens when the tractor gets one wheel in a mud hole. The very time when extra driving force is needed the differential gears rob the motor of its power to move the tractor.

The same thing occurs in a lesser degree in all ploughing work. For, the side-draft tends to place more load on one wheel than on the other and the differential gears throw the power into the other wheel.

More than half the time the Tractor with differential gears is, in effect, a one-wheel-drive tractor.

Pulls itself out of trouble.

The Chase Tractor, having no differential gears, drives both rear wheels with equal power. When the Chase gets into a hole the driver can use both rear wheels to pull out. When obstacles are met, the Chase rides over them. On side-hill ploughing or on level ploughing the side-draft cannot pull the Chase from a true course. The Chase pulls its load more evenly—is easier to control—is more constantly "on the job."

Uses Less Kerosene

This no-differential feature saves kerosene

for two reasons. 1st. Gears waste 10% of a motor's power. The direct drive of the Chase saves that 10%. In addition, the Chase saves the power that would be wasted by the uneven pull due to differential gears.

Avoids Tie-ups and Repairs

Because it pulls evenly the Chase saves wear on bearings, and avoids strain on all working parts. This means less adjusting and less replacement of parts. It means more hours "on the job."

Judge the Chase on Its Construction and Its Performance

The Chase Tractor is a simple, sturdy machine.

It has fewer parts than other tractors—hundreds less than most tractors.

It is a tractor that a farmer can handle easily either in the field or for Belt power, and because of its simple construction and the accessibility of its parts, one that he can attend to with the least trouble and loss of time.

It is a low-riding tractor—gets under trees in orchard work, has sure footing on side hills.

The Chase turns in a narrow radius. By throwing either rear wheel out of gear a sharp turn can be made.

The motor is the heavy-duty tractor type, built to do continuous service without overheating, to give high efficiency on kerosene or low-grade gasoline, to avoid the waste of lubricating oil, which is customary when kerosene is used in ordinary motors. The man who understands and delights in fine machinery should examine the Chase Tractor and watch it in action. The more he knows about tractors, motors and machinery, the greater respect he will have for a piece of engineering construction like the Chase Tractor.

Write for literature and information. Find out, at once, where you can see the Chase Tractor and investigate for yourself the claims we make for it.

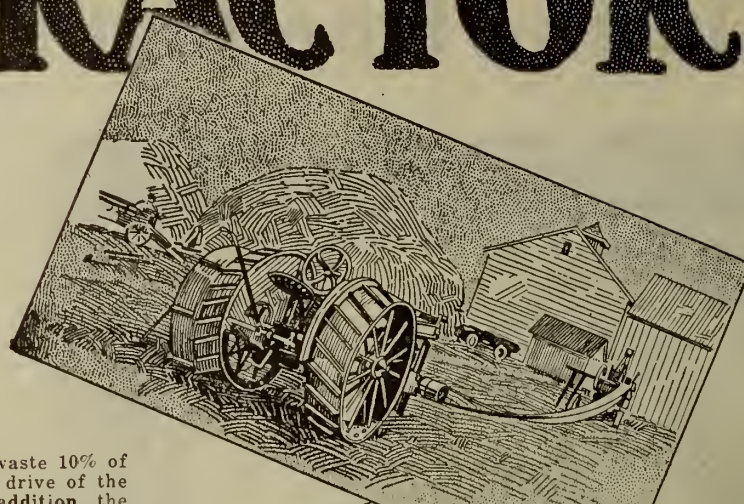

### BEEMAN One-Horse Garden Tractor

Does everything that one horse can do in garden or field work—does it better and faster.

Cultivates as close as a hoe—even in 12-inch rows. Ploughs, harrows, seeds. Hills potatoes. Ideal for market gardeners. Invaluable to farmers.

Has a 4 H.P. Motor for belt-work—and trots from one job to another.

Thousands in use for cutting lawns, golf-courses, parks.

Fully-illustrated literature sent on request—Unusual opportunity for wide-awake dealers everywhere. Write for terms.

CHASE TRACTORS CORPORATION  
LIMITED  
TORONTO - - - ONTARIO

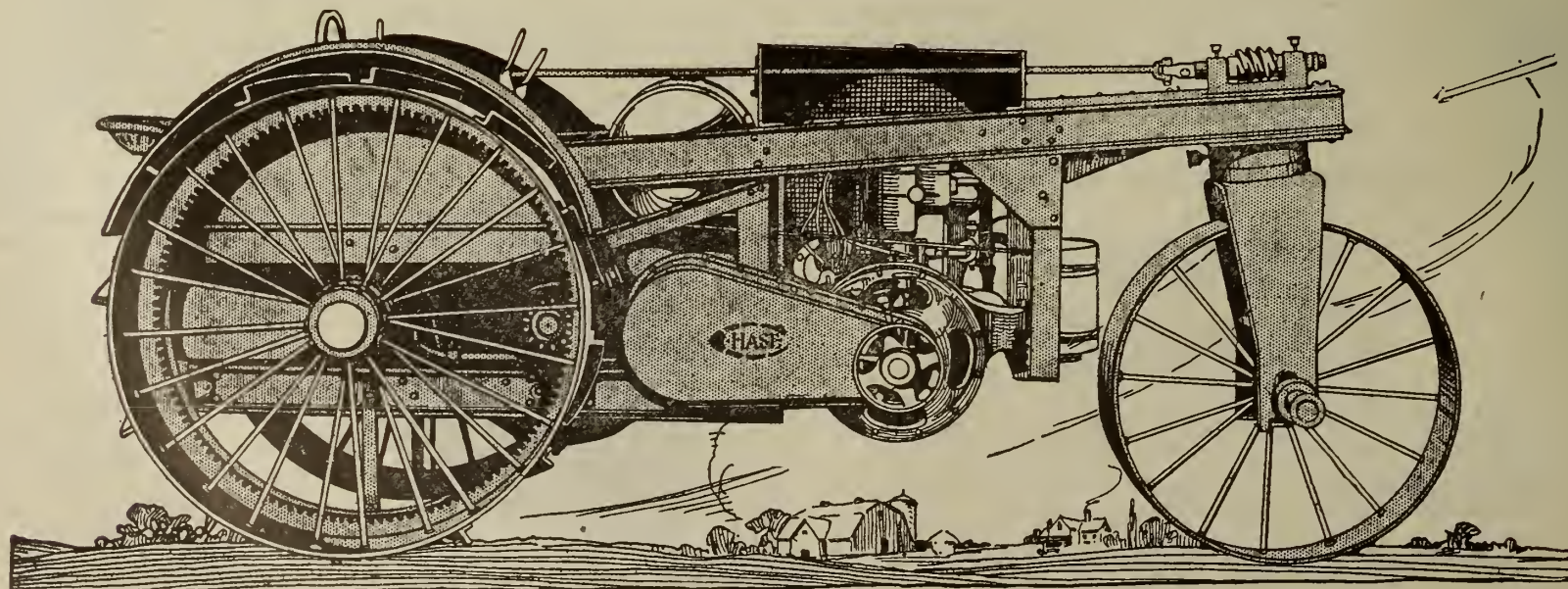





# -they'll follow your example

Put Hold Tite Nut Locks on every automobile, truck, tractor, engine and agricultural implement you sell. It not only gives you, at low cost, a new selling feature of inestimable value, but is the greatest object lesson in "bolt and nut efficiency" you could give your customers.

After one experience with a machine that cannot shake loose your customer will want to follow your example and put "Hold Tites" on all his machinery. Naturally, he will come to you for them.

## "HOLD TITE"---The Nut Lock that says: "It can't Work Loose"

"Hold Tite" says to the nut: "You'll stay put, you can't work loose." It is absolute insurance against loose fastenings.

Under the thousand jars and jolts and the constant stress to which automobiles, trucks, farm implements and machinery are subjected, "Hold Tite" holds tight. No vibration, however severe and long continued, can loosen it.

Inexpensive, simple to put on, impossible to shake loose. Saves the cost of extra nuts and cotter pins, and holds a hundred per cent. better — the cheapest and most positive means of keeping machinery efficient and preventing the quick deterioration that invariably follows in the wake of loose fastenings.

Many manufacturers have made "Hold Tite" Nut Locks standard equipment on their machinery, which should further popularize this wonderful little safeguard. Dealers are finding it increasingly profitable to push "Hold Tite." They make friends everywhere; they've never been known to fail in their duty of holding on like grim death.

### Edward A. Robinson Co., Limited

228 Craig Street West, Montreal

Canadian Offices: Bank of Toronto Chambers, 205 Yonge Street, Toronto, Ont.

322 McIntyre Block, Winnipeg, Man.

American Factory: 166 Montague Street, Brooklyn, N.Y.

Some of the Satisfied Users of the Hold Tite Nut Lock

Belding Paul Corticelli, Ltd., Montreal, Que.

St. Lawrence Wagon Co., Ltd., Montreal, Que.

Frontenac Breweries, Ltd., Montreal, Que.

A. C. Lariviere, Montreal, Que.

Montreal Vehicle Motor Co., Ltd. Montreal, Que.

MacNaughton Motors, Montreal, Que.

Dominion Transport Co., Ltd., Montreal, Que.

George Hall Coal Co., Ltd., Montreal, Que.

M. L. Dohan, Quebec City.

Canada Axe and Harvester Tools Co., Ltd., Montreal, Que.

E. Patenaude, Nomingue, Que

Simple Method of Applying



1st

Use "Hold Tite" of same size as nut, placing it over bolt as illustrated above.



2nd

Screw another nut down onto "Hold Tite" and depress it, as shown in above illustration.



3rd

Remove second nut and "Hold Tite" will be on to stay, as shown above. Simple, isn't it! and as secure as it is simple.



CANADIAN  
**Motor Tractor and Implement Trade Journal**  
**BUYERS DIRECTORY**

This directory will help you with your buying and your planning. The advertisers listed here are thoroughly reliable and leaders in their respective fields. They are looking for live, wide-awake representatives. Study their advertisements carefully because they contain valuable information which will dovetail with your plans. We are glad to go to the trouble of arranging this list—to make it easy for you to select new lines. If it so happens that what you want is not here, write us, and we will tell you where to get it.

**ACCESSORIES**

Advance Machine & Welding Co., Montreal.  
 British & Foreign Agencies, Montreal.  
 Dustbane Mfg. Co., Ltd., Ottawa.  
 Geo. W. Anstett, McGee, Sask.  
 Guelph Spring & Axle Co., Guelph.  
 Holton Hood Clip Co., Windsor, Ont.  
 Lions Ignition Co., New York City.  
 Northern Electric Co., Ltd., Montreal.  
 The Goodyear Tire & Rubber Co. of Canada, Ltd., Toronto.  
 Apollo Plug Mfg. Co., Birmingham, Eng.  
 R. F. Sedgley, Inc., Philadelphia, Pa.  
 Can. Fairbanks-Morse Co., Ltd., Montreal.  
 E. & C. Automotive Import Co., Toronto  
 Kales Stamping Co., Detroit, Mich.  
 Kinzinger Bruce Co., Niagara Falls, O.  
 The Greb Co., Boston.  
 Aikenhead Hardware Co., Toronto.  
 Hyslop Bros., Toronto.  
 The Specialties Co., Montreal.  
 K. P. Products Co., 250 West 54th St., New York City.  
 Perfex Radiator Co., Racine, Wis.  
 Robinson Co. Ltd., Edward A., Montreal

**AUTOMOBILE CHAINS**

Can. Fairbanks-Morse Co., Ltd., Montreal.

**BARN EQUIPMENT**

Beatty Bros., Ltd., Fergus, Ont.

**BEAN MACHINERY**

John Deere Mfg. Co., Welland, Ont

**BEET MACHINERY**

International Harvester Co., of Can., Ltd., Hamilton, Ont.  
 John Deere Mfg. Co., Welland, Ont.

**BINDERS**

The Frost & Wood Co., Ltd., Smiths Falls, Ont.  
 International Harvester Co., of Can., Ltd., Hamilton, Ont.  
 Massey-Harris Co., Toronto.

**BELTING**

The Goodyear Tire & Rubber Co. of Canada, Ltd., Toronto.

**BATTERIES**

Can. Fairbanks-Morse Co., Ltd., Montreal.

**CARRIAGES**

Cockshutt Plow Co., Brantford, Ont.

**CREAM SEPARATORS**

De Laval Co., Ltd., Peterboro, Ont.  
 International Harvester Co., of Can., Ltd., Hamilton, Ont.  
 King Separator Co., Bridgeburg, Ont.  
 R. A. Lister Co. (Canada), Ltd., Toronto  
 Swedish Separator Co., Montreal.

**CEMENT MIXERS**

Can. Fairbanks-Morse Co., Ltd., Montreal.

**CASTINGS**

Joliette Steel Co., Joliette, P.Q.

**CORN HARVESTERS**

Cockshutt Plow Co., Brantford, Ont.  
 International Harvester Co., of Can., Ltd., Hamilton, Ont.  
 Massey-Harris Co., Toronto.

**CORN MACHINERY**

International Harvester Co., of Can., Ltd., Hamilton, Ont.  
 John Deere Mfg. Co., Welland, Ont.

**CULTIVATORS**

Cockshutt Plow Co., Brantford, Ont.  
 John Deere Mfg. Co., Welland, Ont.  
 Massey-Harris Co., Toronto.  
 The Frost & Wood Co., Ltd., Smiths Falls, Ont.  
 International Harvester Co., of Can., Ltd., Hamilton, Ont.

**CUTTERS**

Butterfield & Co., Inc., Rock Island, Q.

**DAIRY SUPPLIES**

International Harvester Co., of Can., Ltd., Hamilton, Ont.  
 R. A. Lister Co. (Canada), Ltd., Toronto  
 DeLaval Dairy Supply Co., Peterboro.

**DIES**

Butterfield & Co., Inc., Rock Island, Q.

**DISCS**

Massey-Harris Co., Toronto.

**DITCHING MACHINES**

Can. Fairbanks-Morse Co., Ltd., Montreal.

**DRILLS**

Massey-Harris Co., Toronto.

**DRILLS, TWIST**

Butterfield & Co., Inc., Rock Island, Q.

**DRILLS, GRAIN**

Cockshutt Plow Co., Brantford, Ont.  
 International Harvester Co., of Can., Ltd., Hamilton, Ont.  
 John Deere Mfg. Co., Welland, Ont.  
 The Frost & Wood Co., Ltd., Smiths Falls, Ont.

**ELECTRICAL EQUIPMENT**

Westco Pump Ltd., Toronto.

**ENGINES**

Can. Fairbanks-Morse Co., Ltd., Montreal.  
 Gilson Mfg. Co., Ltd., Guelph, Ont.  
 International Harvester Co., of Can., Ltd., Hamilton, Ont.  
 John Deere Mfg. Co., Welland, Ont.  
 The Frost & Wood Co., Ltd., Smiths Falls, Ont.  
 Massey-Harris Co., Toronto.  
 R. A. Lister Co. (Canada), Ltd., Toronto  
 Renfrew Mchy. Co., Renfrew, Ont.

**ENSILAGE CUTTERS**

Can. Fairbanks-Morse Co., Ltd., Montreal.  
 Gilson Mfg. Co., Guelph, Ont.  
 International Harvester Co., of Can., Ltd., Hamilton, Ont.  
 Massey-Harris Co., Toronto.

**FEEDERS**

John Deere Mfg. Co., Welland, Ont.

**FARM MACHINERY**

Can. Fairbanks-Morse Co., Ltd., Montreal.  
 Cockshutt Plow Co., Brantford, Ont.  
 John Deere Mfg. Co., Welland, Ont.  
 International Harvester Co., of Can., Ltd., Hamilton, Ont.  
 Massey-Harris Co., Toronto.  
 The Frost & Wood Co., Ltd., Smiths Falls, Ont.  
 R. A. Lister Co. (Canada), Ltd., Toronto  
 Gilson Engine Co., Guelph, Ont.

**FEED CUTTERS**

Can. Fairbanks-Morse Co., Ltd., Montreal.  
 Massey-Harris Co., Toronto.  
 Gilson Engine Co., Guelph, Ont.

**GREASE CUPS**

The Specialties Co., Montreal.

**GRINDSTONES**

S. Vessot & Co., Joliette, P.Q.

**GRINDERS**

Can. Fairbanks-Morse Co., Ltd., Montreal.  
 International Harvester Co., of Can., Ltd., Hamilton, Ont.  
 Massey-Harris Co., Toronto.  
 R. A. Lister Co. (Canada), Ltd., Toronto  
 S. Vessot & Co., Joliette, P.Q.  
 Gilson Engine Co., Guelph, Ont.

**HARROWS**

Cockshutt Plow Co., Brantford, Ont.  
 International Harvester Co., of Can., Ltd., Hamilton, Ont.  
 John Deere Mfg. Co., Welland, Ont.  
 Massey-Harris Co., Toronto.  
 The Frost & Wood Co., Ltd., Smiths Falls, Ont.

**HAY LOADERS**

International Harvester Co., of Can., Ltd., Hamilton, Ont.  
 John Deere Mfg. Co., Welland, Ont.  
 The Frost & Wood Co., Ltd., Smiths Falls, Ont.

**HARDWARE**

Can. Fairbanks-Morse Co., Ltd., Montreal.  
 Massey-Harris Co., Toronto.

**HAY RAKES**

John Deere Mfg. Co., Welland, Ont.  
 The Frost & Wood Co., Ltd., Smiths Falls, Ont.

**HAY CARRIERS**

Beatty Bros., Ltd., Fergus, Ont.  
 Massey-Harris Co., Toronto.

**HAY PRESSES**

Birdsell Mfg. Co., Toronto.  
 International Harvester Co., of Can., Ltd., Hamilton, Ont.

**HULLERS (Clover)**

Birdsell Mfg. Co., Toronto.

**LIGHTNING SYSTEMS**

Can. Fairbanks-Morse Co., Ltd., Montreal.  
 R. A. Lister Co. (Canada), Ltd., Toronto  
 Northern Electric Co., Ltd., Montreal.  
 Gilson Engine Co., Guelph, Ont.

**LIME AND FERTILIZER SOWERS**

John Deere Mfg. Co., Welland, Ont.

**LUBRICANTS**

Imperial Oil Co., Toronto.

**MANURE CARRIERS**

Beatty Bros., Ltd., Fergus, Ont.

**MANURE SPREADERS**

Cockshutt Plow Co., Brantford, Ont.  
 International Harvester Co., of Can., Ltd., Hamilton, Ont.  
 John Deere Mfg. Co., Welland, Ont.  
 Massey-Harris Co., Toronto.  
 The Frost & Wood Co., Ltd., Smiths Falls, Ont.  
 Gilson Engine Co., Guelph, Ont.

**MARINE FITTINGS**

Northern Electric Co., Ltd., Montreal.

**MOWERS**

Cockshutt Plow Co., Brantford, Ont.  
 International Harvester Co., of Can., Ltd., Hamilton, Ont.  
 Massey-Harris Co., Toronto.  
 The Frost & Wood Co., Ltd., Smiths Falls, Ont.

**MILKING MACHINES**

R. A. Lister Co. (Canada), Ltd., Toronto  
 The Macartney Milking Machine Co., Ltd., Ottawa, Ont.

**MILLING CUTTERS**

Butterfield & Co., Inc., Rock Island, Q.

**NUT LOCKS**

Robinson Co., Ltd., Ed. A., Montreal.

**OILS**

Imperial Oil Co., Toronto.

**PISTON RINGS**

WedgeRite Piston Ring Co., Ltd., Montreal.

**PLOWS**

Cockshutt Plow Co., Brantford, Ont.  
 John Deere Mfg. Co., Welland, Ont.  
 The Frost & Wood Co., Ltd., Smiths Falls, Ont.  
 International Harvester Co., of Can., Ltd., Hamilton, Ont.  
 Massey-Harris Co., Toronto.

**POLICE AND FIRE ALARM EQUIPMENT**

Northern Electric Co., Ltd., Montreal.

**POWER AND LIGHT EQUIPMENT**

Northern Electric Co., Ltd., Montreal.

**POWER MACHINERY**

Can. Fairbanks-Morse Co., Ltd., Montreal.  
 John Deere Mfg. Co., Welland, Ont.  
 Massey-Harris Co., Toronto.  
 International Harvester Co., of Can., Ltd., Hamilton, Ont.  
 Gilson Engine Co., Guelph, Ont.  
 Renfrew Mchy. Co., Renfrew, Ont.

**POWER SWITCHBOARDS**

Northern Electric Co., Ltd., Montreal.

**POTATO MACHINERY**

John Deere Mfg. Co., Welland, Ont.  
 Cockshutt Plow Co., Brantford, Ont.  
 Can. Potato Mchy. Co., Galt, Ont.

**PULVERIZERS**

Cockshutt Plow Co., Brantford, Ont.  
 International Harvester Co., of Can., Ltd., Hamilton, Ont.

**PULPERS**

Cockshutt Plow Co., Brantford, Ont.

**PUMPS**

Westco Pump Ltd., Toronto.

**RAKES**

International Harvester Co., of Can., Ltd., Hamilton, Ont.  
 The Frost & Wood Co., Ltd., Smiths Falls, Ont.

**REAPERS**

International Harvester Co., of Can., Ltd., Hamilton, Ont.  
 The Frost & Wood Co., Ltd., Smiths Falls, Ont.

**REAMERS**

Butterfield & Co., Inc., Rock Island, Q.

**ROLLERS**

Cockshutt Plow Co., Brantford, Ont.  
 Massey-Harris Co., Toronto.  
 Hyatt Roller Bearing Co., Chicago.

**ROLLER BEARINGS**

Hyatt Roller Bearing Co., Chicago.

**SAW MILL OUTFITS**

Massey-Harris Co., Toronto.

**SCUFFLERS**

Cockshutt Plow Co., Brantford, Ont.  
 International Harvester Co., of Can., Ltd., Hamilton, Ont.  
 John Deere Mfg. Co., Welland, Ont.

**SEEDERS**

Massey-Harris Co., Toronto.

**SCALES**

Renfrew Mchy. Co., Renfrew, Ont.  
 Can. Fairbanks-Morse Co., Montreal.

**SCREW PLATES**

Butterfield & Co., Inc., Rock Island, Q.

**STABLE EQUIPMENT**

Beatty Bros., Ltd., Fergus, Ont.

**SILOS**

Gilson Mfg. Co., Guelph, Ont.

**SLEIGHS**

Cockshutt Plow Co., Brantford, Ont.  
 International Harvester Co., of Can., Ltd., Hamilton, Ont.

**SILO FILLERS**

Gilson Mfg. Co., Guelph, Ont.  
 International Harvester Co., of Can., Ltd., Hamilton, Ont.

**SOCKET WRENCHES**

R. F. Sedgley, Inc., Philadelphia, Pa.

**SPREADERS, MANURE**

Cockshutt Plow Co., Brantford, Ont.  
 John Deere Mfg. Co., Welland, Ont.  
 International Harvester Co., of Can., Ltd., Hamilton, Ont.  
 Massey-Harris Co., Toronto.  
 Gilson Mfg. Co., Guelph, Ont.

**SPARK PLUGS**

Machine & Stamping Co., Toronto.  
 Champion Spark Plug Co., Windsor, O.  
 Apollo Plug Mfg. Co., Birmingham, Eng.  
 Lions Ignition Co., New York.

**SPARK PLUG CLEANERS**

Champion Spark Plug Co., Windsor, O.

**TELEPHONE APPARATUS**

Northern Electric Co., Ltd., Montreal.

**TRACTORS**

R. A. Lister Co. (Canada), Ltd., Toronto  
 Can. Allis-Chalmers, Ltd., Toronto.  
 Chase Tractors Corp., Ltd., Toronto.  
 Essex Tractor Co., Essex, Ont.  
 The Gray Tractor Co. of Canada, Ltd., Winnipeg.  
 Gilson Mfg. Co., Guelph, Ont.  
 International Harvester Co., of Can., Ltd., Hamilton, Ont.  
 J. I. Case Threshing Machine Co., Inc., Racine, Wis.  
 Massey-Harris Co., Toronto.  
 Renfrew Mchy. Co., Renfrew, Ont.  
 The Turner Mfg. Co., Port Washington, Wis.

**TRACTOR PLOWS**

Cockshutt Plow Co., Brantford, Ont.  
 International Harvester Co., of Can., Ltd., Hamilton, Ont.  
 John Deere Mfg. Co., Welland, Ont.  
 Massey-Harris Co., Toronto.

**THRESHERS**

Can. Fairbanks-Morse Co., Ltd., Montreal.  
 International Harvester Co., of Can., Ltd., Hamilton, Ont.  
 J. I. Case Threshing Machine Co., Inc., Racine, Wis.  
 R. A. Lister Co. (Canada), Ltd., Toronto  
 Gilson Mfg. Co., Guelph, Ont.

**THREAD CUTTING TAPS**

Butterfield & Co., Inc., Rock Island, Q.

**TWIST DRILLS**

Butterfield & Co., Inc., Rock Island, Q.

**TRUCKS**

Motor Car Distributors Ltd., Montreal.  
 Beaver Truck Builders, Ltd., Hamilton  
 Eastern Canada Motor Truck Co., Ltd., Hull, P.Q.  
 International Harvester Co., of Can., Ltd., Hamilton, Ont.

**WHEELBARROWS**

Cockshutt Plow Co., Brantford, Ont.  
 Massey-Harris Co., Toronto.

**WAGONS**

Cockshutt Plow Co., Brantford, Ont.  
 International Harvester Co., of Can., Ltd., Hamilton, Ont.  
 Massey-Harris Co., Toronto.

**WATER BOWLS**

Beatty Bros., Ltd., Fergus, Ont.

**WATER SYSTEMS**

Westco Pump Limited, Toronto.

**WEEDERS**

Cockshutt Plow Co., Brantford, Ont.

**WIRES AND CABLES**

Northern Electric Co., Ltd., Montreal



# Butterfield

## Drills, Taps, Dies, Reamers

### and MILLING CUTTERS

It is after you have completed several jobs with the same Butterfield tool that you begin to appreciate Butterfield Quality.

The way they stand up under long, hard usage, and still retain their accuracy, endears Butterfield Tools to mechanics who take pride in their work.

You will find that Butterfield Tools save you a great deal of trouble and invariably produce a job satisfactory to your customer and yourself.

Shall we send you our latest Catalogue?

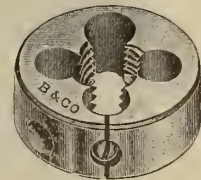
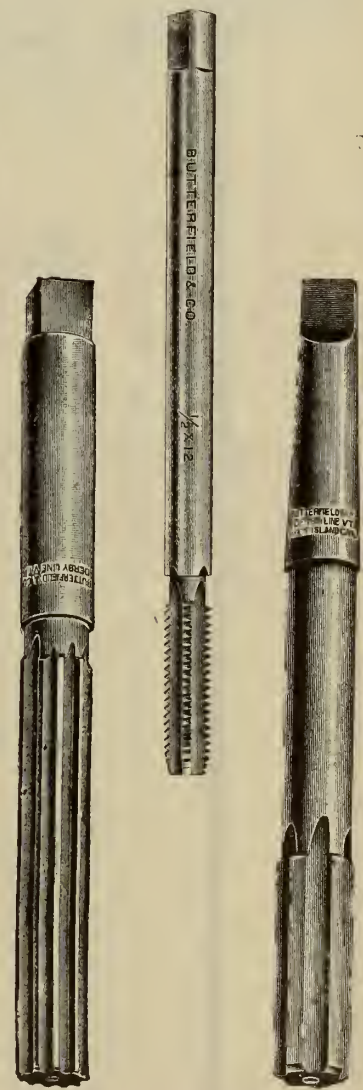
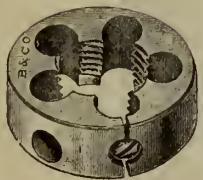

**BUTTERFIELD & CO., ROCK ISLAND, P.Q.**

TORONTO OFFICE: 220 King St. W.





## He Cannot Afford to Experiment

**Y**OUR average farmer realizes the need for special oils for various farm machines and depends on the line of Imperial Farm Lubricants for his requirements.

He and his neighbours in your community use vast quantities of lubricants every year. His business is worth while to you and *highly profitable*.

From the line of Imperial Farm Lubricants you can supply all the requirements of your community. Carry a complete stock—all grades—all sizes.

Become an authority on farm lubrication problems and you can become "oil headquarters" in your town.

Extensive advertising in farm papers reaching the majority of farmers around you is now running. It is a continuation of a campaign of education on farm lubrication problems started several years ago, and the only continuous advertising being done by any Oil Company to help you get this business.

Link up with this advertising, ask our salesman about Imperial Sales Helps.

### IMPERIAL



## Lubricants

**IMPERIAL POLARINE AND  
IMPERIAL POLARINE HEAVY**  
For all gasoline-burning engines—  
automobiles, tractors and trucks.

**IMPERIAL POLARINE A**  
For all motors requiring an un-  
usually heavy oil.

**IMPERIAL POLARINE  
KEROSENE TRACTOR OIL  
AND IMPERIAL POLARINE  
KEROSENE TRACTOR OIL  
EXTRA HEAVY**

For kerosene-burning stationary  
engines and tractors.

**IMPERIAL PRAIRIE  
HARVESTER OIL**

A heavy-bodied oil for open bear-  
ings of threshers, binders and sep-  
arators.

**IMPERIAL ELDORADO  
CASTOR MACHINE OIL**

A thick oil for worn and loose  
bearings.

**IMPERIAL CAPITOL  
CYLINDER OIL**

For steam cylinder lubrication—  
tractors and stationary engines.

**IMPERIAL STANDARD  
GAS ENGINE OIL**

For stationary and portable engines  
using either kerosene or gasoline.

**IMPERIAL ARCTIC  
CUP GREASE**

Made in different consistencies.

Imperial Farm Lubricants are for  
sale in 1/2, 1 and 4 gallon sealed  
cans, half-barrels and barrels.

**IMPERIAL OIL LIMITED**  
Power - Heat - Light - Lubrication  
Branches in all Cities





# Beaver Trucks

*"Built For Business"*

**Built in Canada's Largest  
Exclusive Truck Factory**

**UNQUESTIONABLY  
"CANADA'S LOWEST HAULING COST"**

Some open territory still available—Catalogues and further information furnished responsible dealers upon request.

**Beaver Truck Builders, Limited**  
HAMILTON, ONTARIO



# JUMBO

## Cuts Down Your Haulage Costs



Built in sizes 1½, -2, -2½, -3, -3½, -4 tons

## PUT YOUR LOAD ON A JUMBO

For years JUMBO Trucks have stood the gaff day in and day out under severest conditions in all parts of the world.

Because of its superior design, oversize construction, brute strength, highest quality units and workmanship, the JUMBO has established a world wide reputation for economic and dependable service.

Service costs per year for JUMBO Trucks in operation last year averaged less than ten dollars per truck. A truly remarkable tribute.

JUMBO is the first completely equipped heavy duty internal gear truck in Canada.

An Investment in a **JUMBO TRUCK** Would Pay Big Interest

WRITE FOR COMPLETE SPECIFICATIONS AND DETAILS

*Sole Distributors in Canada*

**Motor Car Distributors, Limited**  
27 McGill College Avenue, Montreal, Que.



CANADIAN  
**MOTOR, TRACTOR AND IMPLEMENT**  
 TRADE JOURNAL

Published Monthly by THE MACLEAN PUBLISHING COMPANY, LIMITED, TORONTO

MONTREAL, Southam Bldg.

WINNIPEG, 1103 Union Trust Bldg.  
 NEW YORK, 1133 Broadway.

VANCOUVER, 314 Carter-Cotton Bldg., 198 Hastings St. W.  
 BOSTON, 734 Old South Bldg.

CHICAGO, 405-6 Transportation Bldg.  
 LONDON, ENG., 88 Fleet St., E.C. 4

VOL. II, No. 7

TORONTO, JULY, 1920

Subscription Price  
 \$2.00 Per Year

*Apollo*

**SPARKING PLUGS**

—are sure and satisfactory sellers!

You're on a good thing when you handle APOLLO PLUGS—they represent the highest standard of British plug manufacture, are fully tested to ensure maximum efficiency and are guaranteed to give complete satisfaction.

With the APOLLO range of plugs you can promptly meet every plug request—there are models for every type of Car, Motor Truck and Tractor engine—and every plug carries a GOOD PROFIT for YOU.

Super Mica Plug, is specially designed for high-speed, high-compression engines. It is unaffected by excessive heat and of exceptional durability—a plug that gives a quick start and adds power to the engine. Retails in the U.K. at ..... **6/-**

Porcelain Plug is specially designed for the FORD engine. It has Solid Brass body, 1/2-in. gas thread, is clean to handle, will not rust, fits the special Ford spanner, is insulated with finest porcelain and is detachable for cleaning. Retails in the U.K. at ..... **5/-**

Get on to the APOLLO PLUG proposition and you'll do big business in selling plugs. We can give prompt shipment of all models and supply you with posters, showcards and advertising literature. Write us for trade terms and full particulars of our models.

**APOLLO PLUG MFG. CO.**  
 Moseley Street                      Birmingham, England

Codes: A.B.C. 4th Western Union

Plugs for                      all engines



APOLLO  
 No. 1.  
 Super  
 Mica  
 Plug



APOLLO  
 Special



APOLLO  
 L.C.B.  
 Special  
 FORD  
 Plug

Overtime  
 Tractor  
 Plug



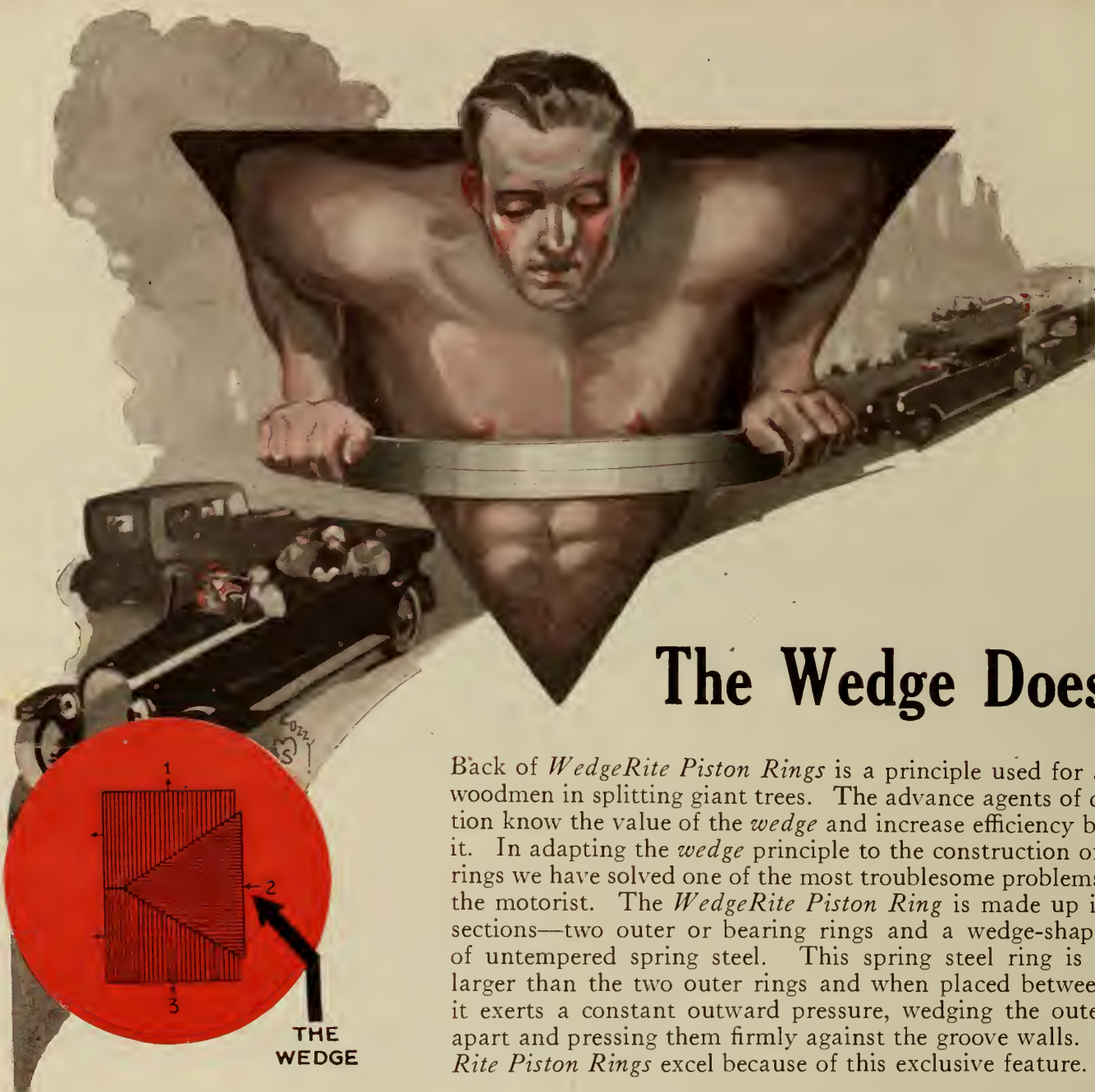

## The Wedge Does It

Back of *WedgeRite Piston Rings* is a principle used for ages by woodmen in splitting giant trees. The advance agents of civilization know the value of the *wedge* and increase efficiency by using it. In adapting the *wedge* principle to the construction of piston rings we have solved one of the most troublesome problems facing the motorist. The *WedgeRite Piston Ring* is made up in three sections—two outer or bearing rings and a wedge-shaped ring of untempered spring steel. This spring steel ring is slightly larger than the two outer rings and when placed between them it exerts a constant outward pressure, wedging the outer rings apart and pressing them firmly against the groove walls. *WedgeRite Piston Rings* excel because of this exclusive feature.

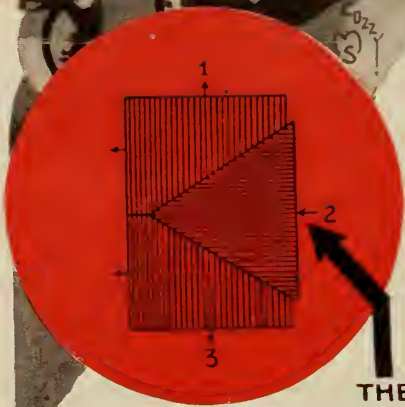

THE WEDGE

### CROSS SECTION OF RING

1. Section pressing outward and upward.
2. Spring section of ring.
3. Lower outward and downward section.

### ILLUSTRATING THE WEDGE PRINCIPLE

The Wedge principle employed in the making of *WedgeRite Piston Rings* is shown in the accompanying drawing. Its superiority, measured by its ability to expand in WIDTH, as well as in diameter, means utmost satisfaction for motorists.

## More Power—Smoother Operation

*WedgeRite Piston Rings* are power boosters for the farm tractor. Running along the level, over rough ground, or up an incline, *WedgeRite Piston Rings* hold tight giving the engine every ounce of power generated. You cannot do a better stroke of business than sell a farmer friend a set of *WedgeRite*. They will save him money and give him more and smoother power. He will want a set on his motor car, too.

Explain to your customers the principle of *WedgeRite*. It is so obviously correct any user of gasoline power will see it.



**WedgeRite**  
PISTON RING  
COMPANY  
LIMITED

92 Notre Dame Street E., MONTREAL

Order from Your Favourite Jobber



# The Cream Separator with the REAL Self-Balancing Bowl

*The Practical Milker for  
the Practical Farmer*



## Reduce Milking Time *with the* **LISTER MILKER**

Increase your herd, too, and have more dairy products to sell at high prices! Surely it is worth any farmer's while to do these things and pay for a Lister Milker out of the extra profits.

The Lister does its work to perfection with fewest parts. A triumph of modern invention, that means lowest expenditure of time and money for repairs. And it is so simple that any intelligent person without experience can operate it with ease.

We stand behind every Lister Milker with the world-wide Lister reputation for quality and reliability. A system of regular inspection is maintained by the company. Write for literature to-day.



### Other Lister Lines

EVERY FARM TRACTOR (a size for every farm)—LISTER ENGINE—LISTER SILOS—LISTER GRINDERS, etc.

### Announcement to Dealers:

get prospects' names sent in. If there is no dealer in your vicinity write us for agents' proposition and full particulars about the famous Lister lines of Farm Machinery.

The above are typical advertisements of a series appearing in farm papers throughout the year. All Lister agents should

ALL over Canada farmers are welcoming again the farmer's friend, the original, genuine Melotte, famous the world over for honest quality, for easy cleaning, easy running—and closest of close skimming.

The original Melotte is available in all sizes with full line of repair parts and equipment. Beware of imitations, and remember that the original

## MELOTTE Cream Separator

is sold in Canada only by R. A. Lister & Company (Canada) Limited.

If you are using an old, worn out machine, you are more than likely losing each year, enough butter-fat to pay for the close-skimming, original Melotte—the separator with the real self-balancing bowl.

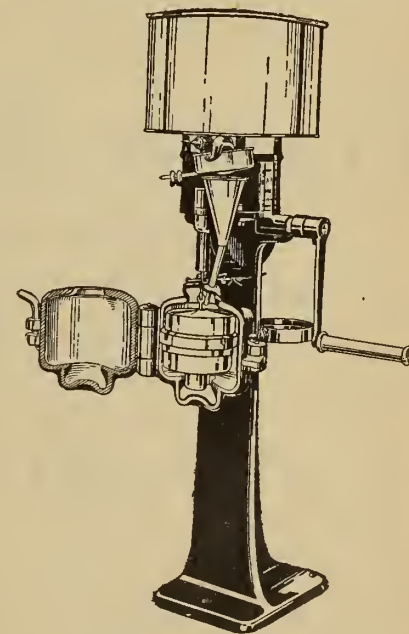

## R. A. LISTER & CO. (CANADA) LIMITED

58-60 Stewart Street, Toronto. Also at Wall Street, Winnipeg



# *"The Wonderful Gilson"*

MADE IN CANADA



## IT STANDS SUPREME

### REASONS WHY:—

- 1—Your Customers Demand the Gilson—Easy Sales—Big Commissions.
- 2—It has the largest sale of any Silo Filler under the British Flag.
- 3—Its wonderful performance brings repeat orders.
- 4—It is the lightest running blower cutter made.
- 5—Our entire organization is behind you.

## *Frankly Now, Doesn't It Look Good?*

You cannot afford to let this proposition go!

Don't put it off—write for our special agent's proposition at once.

Tear off, fill in and return the corner of this page. If you don't some one else will.

## IT MEANS DOLLARS TO YOU!

### Gilson Mfg. Co. LIMITED

Factory and Head Office:  
10118 York Street  
GUELPH, ONT.

Branch and Warehouse:  
10128 Elgin Ave.  
WINNIPEG, MAN.

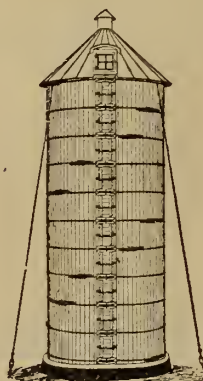

### The Hylo Silo

No farm is complete  
without the famous  
Hylo.

**BIG PROFIT—  
EASY SALES**

*Something worth adding  
to your lines.*

Without any obligation on my part you may send me your agent's proposition on:—

Silo  
 Silo Filler  
 Engine  
 Thresher  
 Manure Spreader  
 Tractor

Name .....  
 Post Office .....  
 R.R. No. ....  
 Remarks.....

**FILL IN AND RETURN AT ONCE**  
**TEAR OFF HERE**  
 (Put an X opposite the product that interests you)



# Universal Cylinder Reboring Tool



*This Tool gives better service and makes a bigger profit, so*

Why send automobile, truck, tractor or gas engine cylinders to the factory to be rebored when you can do them just as well in your own garage.

Think of the improved service you could give your customer, the time you could save him, the freight charges you could eliminate, the hundred and one delays you could avoid.

Think of the additional revenue reboring would bring you, even if you didn't do more cylinders than you are sending to the factory now. And you know there would be much more reboring done if it didn't lay a car up for so long.

With a Universal Cylinder Reboring Tool in your garage you can do as good a job on any cylinder as could be done in the factory. You can operate it with power or by hand and get equally good results.

It is used by the manufacturers of the Ford, Dodge, Studebaker, Buick, Chalmers, and many other cars and trucks.

Wherever it has been used it has proved a profitable investment, and has met every requirement as to accuracy, workmanship and general excellence.

*Clip this coupon and mail it to us for further information*

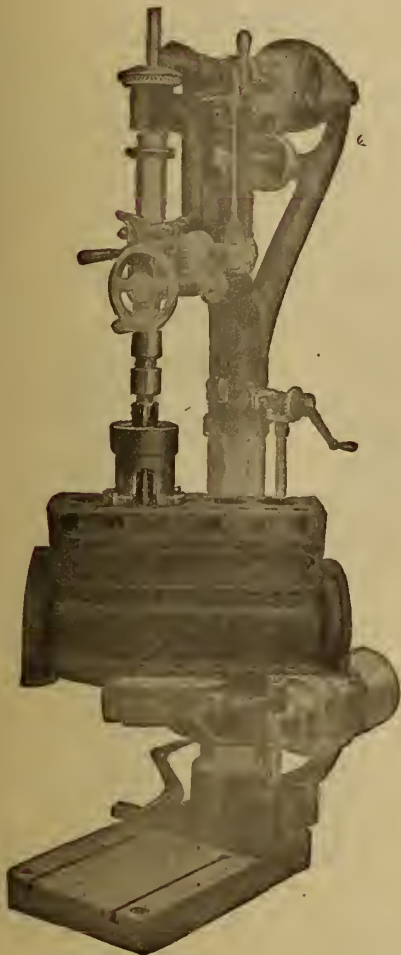

Operating with power-driven drill press

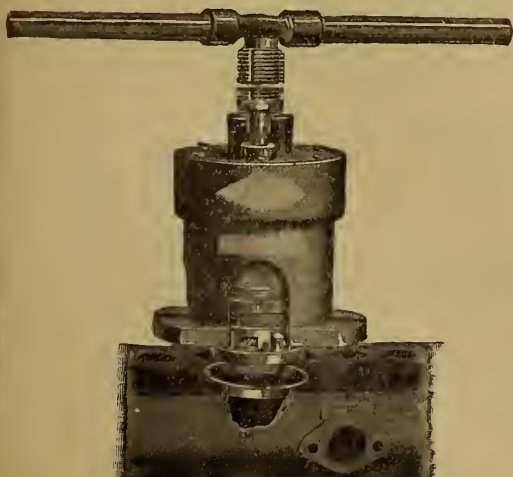

Operating on a detachable head motor—by hand

**Windsor Machine and Tool Works**  
86-88 Pitt Street, Windsor, Ontario

I, (or we) are interested in the UNIVERSAL CYLINDER REBORING TOOL, and would like to get more information on this equipment. You claim it will materially increase profits of this business; if so, I, (or we) are anxious to know about it.

Send any literature pertaining to same to

Name ..... City.....  
Street ..... Prov.....  
We repair the following cars .....  
Name of my jobber .....



# We Have Created the Demand You Only Need to Supply It

For years we have been building a reputation for the dependability of Champion Spark Plugs. To-day "Champion" on the insulator of a spark plug is the world's synonym for dependability.

Spark plug users have come to realize that "Champion" means satisfactory, efficient spark plug service.

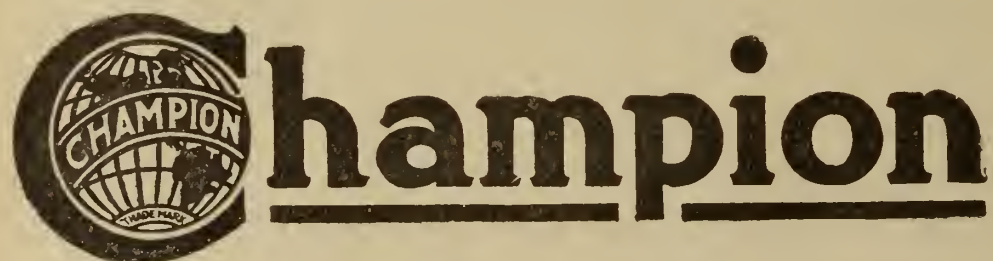

## Dependable Spark Plugs

have been selected as regular factory equipment by over 300 manufacturers of automobiles, trucks, tractors, farm and stationary engines, motor boats, and motor cycles in Canada and the United States.

The demand for "Champions" is already established. All you have to do is to supply that demand, and take your share of the business our advertising has created for you.

Keep your stock of Champions complete that you may be able to, at all times, supply the demand.

**Champion Spark Plug Company of Canada, Limited**  
Windsor, Ontario

*Largest factory in Canada making Spark Plugs exclusively and the only factory making "Champions"*

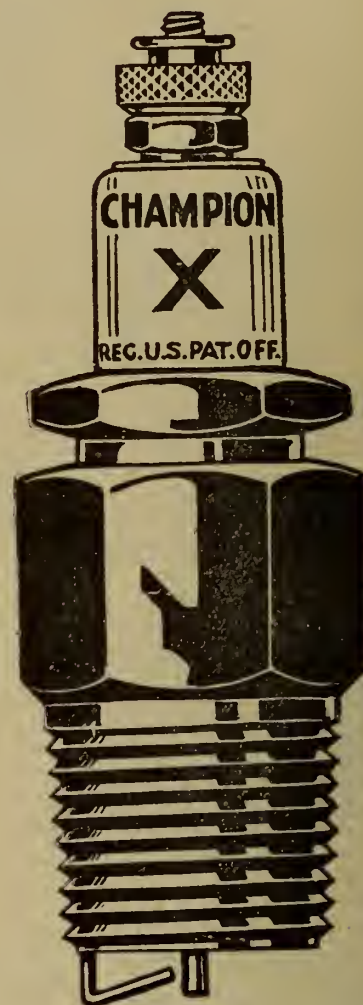

### Champion "Heavy Stone"

B-13, 1/2-inch      B-53, 7/8--18 long  
B-43, 7/8-inch, 18      B-73, 3/4-inch  
B-83, 3/4-in. long  
Price \$1.25

Specially adapted for heavy service cars, tractors, trucks, farm and stationary engines.



# JOHN DEERE PLOWS FOR JOHN DEERE DEALERS

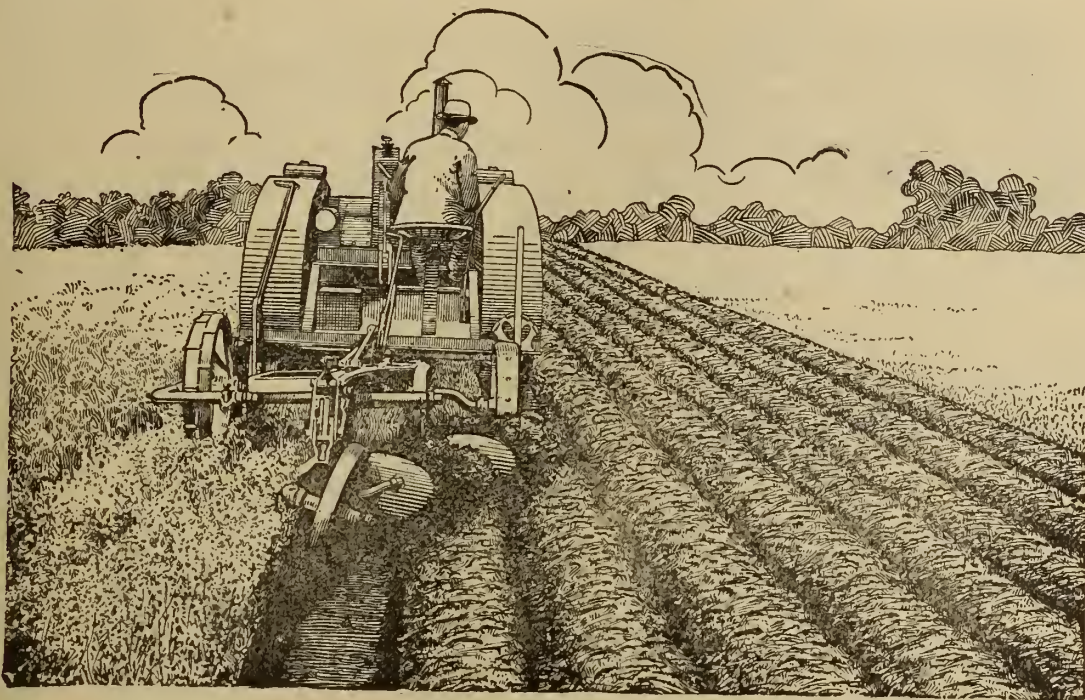

“The One  
Best Line  
for the One  
BEST DEALER”

JOHN DEERE  
Implements  
Are Sold ONLY  
by JOHN DEERE  
DEALERS

## Why YOU Should Handle the J. D. Line

JOHN DEERE dealers have had unqualified success in handling the JOHN DEERE line of implements. Backed up by quality and an ever-increasing demand, dealers have found them easy to sell. They have made satisfied farmers and this has meant more sales.

This year we are advertising JOHN DEERE PLOWS especially designed TO MEET SOIL CONDITIONS IN ONTARIO. 83 years' experience in plow building is back of these plows. Ever since JOHN DEERE invented the first steel plows. We have been leaders in our field. Mechanically perfect and constructed of the highest grade materials, they maintain the usual JOHN DEERE standard of quality.

### The JOHN DEERE Quick Detachable Share

It saves 80% of time and is removed by loosening one bolt. Share fits snug and tight and wears longer because made of high carbon steel. This feature alone should sell many plows.

### TRACTOR HITCH for NEW DEERE Gang

is another feature. It can be supplied for New DEERE gang plows. Learn more about the line. Write us at once.

Our business-like policy is another reason why you should handle this line. WE SELL ONLY THROUGH DEALERS. They can be bought nowhere else. This policy is winning us many friends.

Backed up by liberal advertising in farm papers—with special folders profusely illustrated—with the help we give our dealers, you are in a position to CASH IN on the plow business in your locality this fall.

Point out the quality, workmanship and exclusive features of these plows. The rest is easy.

Write for particulars of the full line and open territory.

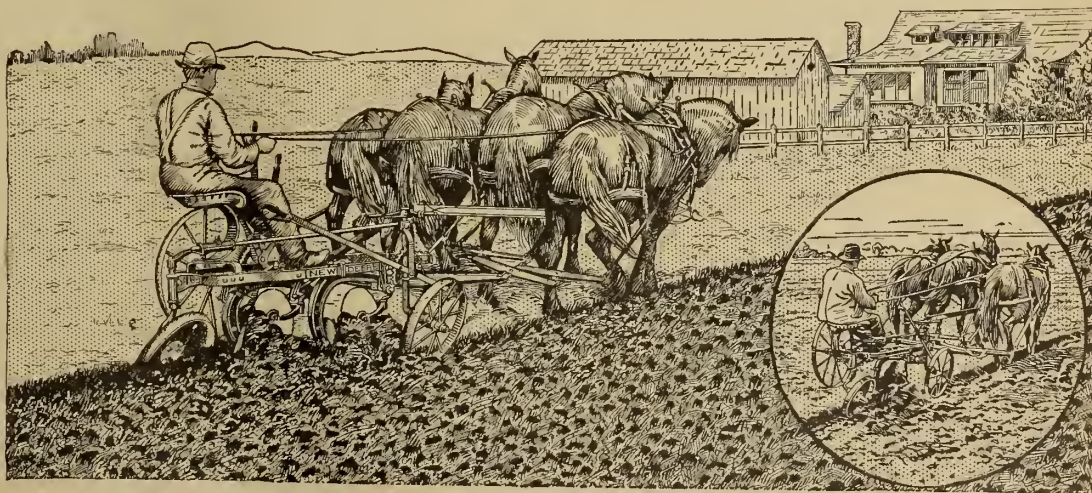

WALKING PLOWS, TRACTOR PLOWS, SULKY AND GANG PLOWS

THE JOHN DEERE MANUFACTURING CO., LIMITED

WELLAND



ONTARIO



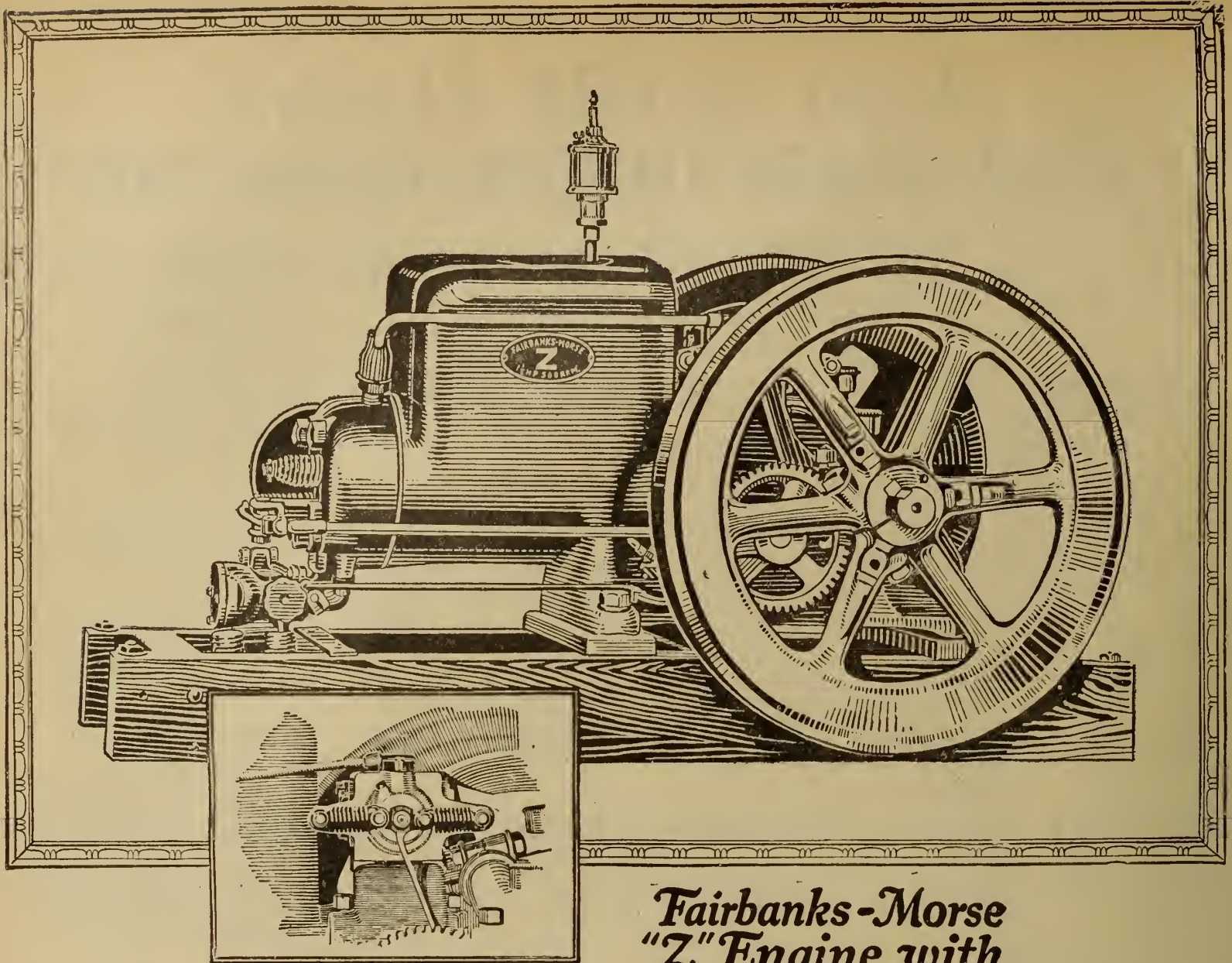

*Fairbanks-Morse  
"Z" Engine with  
Bosch Magneto*

## Now-There is Only One Farm Engine

JUST think of the famous "Z" Engine with a Bosch high-tension, oscillating magneto—which delivers a steady succession of hot, intensive sparks. ¶ Every farmer in Canada should at once call on the nearest "Z" Engine dealer and see the result of this recent epoch-making combination—FAIRBANKS-MORSE "Z" ENGINE WITH BOSCH MAGNETO. ¶ Mechanical perfection, plus power—and right price—to date sold the "Z" Engine to over 250,000 farmers. ¶ This quality and quantity production enabled us to contract for a large proportion of the extensive Bosch facilities for making this one possible "Z" betterment, which establishes a new farm engine standard. ¶ And all Bosch Service Stations throughout Canada will assist our dealers in delivering maximum engine service.

*The Canadian*

MADE IN TORONTO, CANADA BY

# Fairbanks-Morse

*Co., Limited.*



Halifax  
Hamilton

St. John  
St. Catharines  
Calgary

Quebec  
Windsor  
Vancouver

Montreal  
Winnipeg  
Victoria

Ottawa  
Regina

Toronto  
Saskatoon





# CANADIAN MOTOR, TRACTOR AND IMPLEMENT TRADE JOURNAL

Volume 2

TORONTO, JULY 5, 1920

Number 7

## General Survey of the 1920 Crop Prospects

### Reports from the West Indicate that the Farmers Will Cash in on a Bumper Crop. While the early Crops in Ontario are not so Good the Prospects over the Dominion Generally are Encouraging

**P**RIMARILY, it is the farmer who is interested in the prospect for the coming harvest. To him it means the reward, great or small, for his organized that other factors modify the degree to which year's labor. For although his business may be so or he can probably turn his soil products into cash, the soil products themselves are the fundamentals with which he has to work.

And as the products of the soil—the crops—constitute the basic factor in determining the farmer's profit for the year, so also do they constitute the basic factor in determining the dealers' and thence the manufacturers' profit for the year. For the farmer must be able to buy before the dealer can sell, and the dealer must be able to sell before he can, in turn, buy of the manufacturer.

The question then, of the crop prospects for 1920, is of almost as great moment to the dealer as to the farmer himself. According to crop prospects, the wide-awake dealer will lay his plans for the coming year.

**D**ESPITE the untoward tendencies of early spring, latest reports from the West are more than satisfactory. They are rosy.

It will be remembered that the early spring was most backward. Long after the usual time for the commencement of seeding, snow lay deep on the ground and more came every day.

Then when the seed had been finally sown, it was scarcely more than sprouted when the grasshopper menace began to show itself of enormous proportions. All of which was decidedly depressing.

But, given any kind of a chance, the crops of the West are marvelous in their powers of recovery.

Thanks to the persistent efforts of the Provincial Departments of Agriculture, and of the farmers themselves, the grasshoppers have been brought under control, early enough in the season that even badly infested fields have been able to effect a recovery beyond the anticipations of the most optimistic. Then in the middle of June, just at the most propitious moment showers were almost universal.

**I**N Southern Saskatchewan it is reported that on June 14th, one and one-quarter inches of rain fell. This is perhaps greater than the average, but in most cases the precipitation was sufficient to establish a connecting film between the surface and the underlying soil water table. Thus capillary action will continue to supply the crops with abundant moisture during their period of fastest growth.

Following the showers the growing weather has been ideal. A number of correspondents have re-

ported as much as five inches of growth, by actual measurement, in a single week.

Reports from Saskatchewan state that wheat was eighteen inches high and headed out, over a large acreage, shortly after the middle of June.

**T**HE reports from southern Alberta indicate conditions better than have prevailed since 1915—the last year of good crops in that section.

In a few areas in Alberta high winds, and consequent soil drifting, have caused very considerable damage. But these areas are relatively small, and even there, experts are of the opinion that the recent rains will bring along some crop on sixty or seventy per cent. of the blown land.

Altogether, it may be predicted that, barring an early frost, the West will harvest a better crop than for some years past.

**I**N the East, conditions are somewhat different than in the West. While the crops still constitute one of the basic factors governing farm profits, the Eastern farmer is not so entirely dependent thereon. For the farmer of the eastern provinces sells relatively little in the shape of raw products of the soil.

Instead he turns them into the form of milk, beef, or wool, and markets them as animal products. So

while he depends on his own farm for the production of rough feeds, he buys a great deal of grain concentrates from the West.

Hence an abundant crop on the prairies insures a fair amount of prosperity for the East as well as for the actual Western producer.

Of course, the eastern dairyman or beef-raiser cannot buy *all* of his concentrates and make much profit, but the fact that most of his income is from the sale of live-stock products renders him less liable to failure through mediocre crops on his own farm.

**I**N Ontario, this year, the spring was also very backward. Wheat and clover came through the winter in splendid condition, but were met by several weeks of cold growth-inhibiting weather.

Spring seeding was delayed, and much seed was sown in a poorly prepared seed-bed. When growth really commenced it was rapid, but another check was put on it by a drought of several weeks.

The June rains have saved the day for the later grain crops, and for corn and roots, but hay and the early grains are bound to be short.

It is estimated that hay will yield about two-thirds of a normal crop. But while wheat and barley will necessarily be short in straw there is reason to believe that a continuation of favorable growing weather will bring about a very fair yield of grain. And the present hot weather is ideal for the growth of silage corn, now such an important crop in all parts of Ontario.

The shortage of hay cannot fail to cause some disadvantage to Ontario farmers, but with the prospect of a fair corn yield, and available concentrates from the West, it is not thought that the feed situation next winter will be as acute as in the one just passed.

**F**RUIT prospects, especially for the tender fruits, were never better. Fruit growers from both the Niagara district and the Blenheim district in southwestern Ontario, report an abundant setting of all kinds of fruits and excellent growth up to the present. Strawberries now on the market are good in both size and quality.

Information from the Provincial Fruit Inspectors office, in British Columbia, is to the effect that conditions there are most favorable, and it is anticipated that the yield will be even greater than that of last year.

Altogether, for the Dominion as a whole, the season of 1920 promises to do much to increase the supply of food products, thereby relieving some of the strain on the consumer, but at the same time assuring the producer, and hence the country generally, of greater prosperity.



—Hunter in Toronto "Globe"  
Premier Drury—"Isn't it good to get back to where the robins are real robins and the folks are real folks!"



# The Pneumatic Tire and the Farm Truck

**T**HE advent of a successful pneumatic tire for trucks has opened up a tremendous field for the sale of motor freight carriers, and truck dealers are now in a position to conscientiously recommend and sell trucks that are of practical value in the farm field.

The development of motor truck transportation has been rapid. It started with the converting of more or less passenger automobiles into carriers of freight. Then came the heavy lumbering vehicle with an extra strong frame, a heavy duty engine and transmission to suit. And solid tires were the only possible tire equipment.

These trucks found their best fields of usefulness in the cities where excessively big loads had to be taken over comparatively short distances. Lighter trucks patterned after the same design also became popular in spite of the fact that obvious difficulties were not overcome in the designing.

In the same way that bicycles were first equipped with tires of solid rubber and are now on pneumatic tires, truck and tire engineers realized that the same development would take place in trucks. And after years of experimental work and at least five years of final tests under the most severe conditions it can safely be said that the pneumatic truck tire is now a practical and essential factor in motor truck transportation. It has proven to be such a success in inter-city transportation and for farm work in the United States that the movement is spreading to Canada much more rapidly than can conveniently be taken care of by the truck and tire manufacturers.

**T**HERE are two distinct advantages of pneumatic equipment, namely, tractioning and cushioning.

Under the head of "tractioning" we find a most important advantage and one that applies very strongly to farmers who are prospective truck owners.

On soft wet roads big pneumatic tires, with their greater road contact area and with a tread designed to furnish the maximum traction, are ideal. A great number of Canadian truck owners have found this particularly beneficial in the winter time when trucks so equipped ran even with several inches of snow, over ground that motor trucks on solid tires could not be operated on. A solid tire going over the road, even when the surface is comparatively smooth, does not grip smoothly and evenly. The engines on solid tired trucks are, therefore, not able to work smoothly, with a steady flow of power to the driving wheels. With pneumatic equipment, this very rough condition is eliminated and the engine can continue at a steady speed and thus operate much more economically.

Truck engineers estimate the saving of fuel consumption with pneumatics at from 15 to 30%, a big part of which may be easily attributed to "cushioning." Pneumatic tires do cost more than solid tires, but even without considering such a saving as 25% reduction in the gasoline and oil bills, the money comes back to the truck owner in the lessened depreciation to his truck.

A \$2,000.00 investment in a truck spread over five years means an expense of \$400.00 a year. With pneumatic tires even such authorities as the Society of Automotive Engineers believe the life of a truck can be doubled. The S. A. E. finds the average life of a solid tired truck to be 60,000 miles, whereas pneumatic tired trucks is from 100,000 to 102,000 miles.

**I**T is clear therefore that a truck investment of \$400.00 per year becomes \$200.00 per year when pneumatic tires are used. The same cushioning that prevents depreciation prevents breakage. And repair bills can also be tremendously reduced when a truck rides on a cushion of air.

By G. R. DONALDSON

Goodyear Tire and Rubber Company

When the time comes when real salesmanship is required to sell trucks, there is an advantage in the use of pneumatic truck tires that should not be lost sight of. In the great majority of cases the farmer who buys a truck will drive it himself. And a demonstration of an easy riding quality of truck so equipped would do much to complete sales.

**B**EFORE leaving the subject of cushioning it should be noticed that trucks used in hauling livestock most certainly should be riding on pneumatic tires. The lessened shrinkage alone would pay for such equipment.

And in these days when everyone who uses his own or someone else's automobile is urging on the various authorities the need for good roads, the destructive effects of solid tires and the ability of pneumatics to run on a road without damaging it, are important considerations.

The dealer organization of this country can benefit by the experience of dealers throughout the United States who have already passed through the first



A farm truck, equipped with pneumatic tires, starting to ford a creek and haul its load over the worst kind of roads. Truck engineers estimate the saving of fuel consumption with pneumatics at from 15 to 30%.

stages of the coming of motor trucks. They can prepare now for the business that is going to be tremendously important in the future.

At the present time it is generally admitted that the demand for automobiles and trucks far exceeds the supply. The same authorities say that in two years' time this condition will be reversed. Then real honest-to-goodness merchandising will be necessary for the dealer who wants to stay in business. And the secret of good merchandising is to give service.

Truck dealers who wish therefore to give service will have to do more than to merely advertise themselves as Service Stations, for this or that kind of trucks, or this or that kind of tires. The business will go to those dealers who understand the product that they are marketing and will do everything in their power for their customers to receive the greatest possible benefit from their purchases. And because the giant pneumatic tires will be such an important factor in the sale of motor trucks to farmers these farm dealers should prepare to give service on them.

**N**O tires will wear indefinitely. It is the responsibility of every dealer who sells a pneumatic equipped truck to carry spare tires and spare tubes of the sizes that are used in his locality.

And almost as important as the carrying of adequate stocks is that of helping his truck owner customers secure the last possible mile of service from his tires.

The enemies to long tire mileage are well known and include such things as poor alignment of the

wheels, lack of brake equalizing, improper inflation, inattention to tread cuts, etc. From a dealers' standpoint, therefore, the first consideration is to recognize the

inherent abilities of motor trucks equipped with pneumatic tires to meet the needs of the farm field. And such an understanding can only be secured by studying carefully all of the available data on the developments in the designing of trucks.

Equipped then with an intelligent grasp of the subject, dealers will be able to sell trucks with a clear recognition of their value to the farmer in his work in the farm fields. And having mastered the subject, the need for giving service, which in the writer's opinion is vitally important, will be really understood.

## Selling Milking Machines

**S**INCE the introduction of the Cream Separator there is perhaps no line of goods more promising from the point of view of easy sales and wide distribution than the mechanical milker.

The owners of only ten or twelve cows are inquiring about milking machines, whilst the man who milks anything over twelve cows is a sure prospect. The time is past when the milking machine was a doubtful proposition as regards its practical use. There are many standard makes of milkers, all of which are giving excellent satisfaction, and if anyone of them falls down, the fault can be looked for, not in the machine, but in the method of using and caring for it.

Wherever a few milking machines have been installed that locality is liable very shortly to be full of these machines. In other words the sceptical farmer has only to see the machine in operation to become convinced that it will save him also time, labor and money. Of course, it is necessary for the dealer to do a little more talking in selling a milking machine than is the case with a cream separator, but once he has two or three sales to his credit, he will be surprised how easily more sales are made.

The proper installation of the milking machine is of vital importance, and most firms manufacturing or selling milkers have their own experts to install their machines. This undoubtedly is by far the best course for all concerned, as for the sake of their reputation the manufacturers will see to it that the machine is satisfactorily installed, and this means a satisfied customer and a satisfied agent. In some cases where an agent has worked up a big sale he can hire his own expert installers, which works out very well, but it will be obvious that he must have a good territory and good sales in order to keep an expert employed constantly.

The care of the milking machine after installation is also of great importance as it is not to the agent's interests to have any machine lying around idle. Many manufacturers of milking machines will provide an annual supervision and overhaul for a small fixed sum. This relieves the agent of a great deal of responsibility and ensures that the machines are well cared for and kept in proper repair. As to the type of milker, and there are several different types this is naturally a matter for the individual to decide for himself. His best guide in this matter is the standing reputation of the firm which manufactures and sells the machine. A live agent will not neglect the milker agency. If he does he may be quite sure that some other man will step in and get the business, as the business is there and only wants looking after.



# Have You the Power Farming Vision?

IT is pretty hard to convince someone else of something which you yourself do not believe. The salesman who does not believe in the line he handles will not be as good a salesman, other things being equal, as the man who considers the line which he handles to be the best of its kind, and believes that it is really to the advantage of the public to use his product.

The implement dealer is in one sense of the word only a salesman. If he does not have the power

By ARNOLD P. YERKES

that the man selling such equipment will do a larger business and must think and deal in larger figures than in the past.

For one thing, farming is rapidly changing over from animal to mechanical power. Perhaps it is not quite correct to say rapidly, although considering the

business in his territory. The dealer who gets the bulk of the tractor business is usually the one who believes in it most firmly and who has studied it carefully so as to know what types of machines are giving the greatest satisfaction on farms in his territory and be prepared to answer farmers' questions intelligently and so be of real help to his customers in choosing their power equipment as well as in re-organizing their farm business to utilize mechanical power to the best advantage.

It really does not require much vision to see clearly that the change from animal to mechanical power equipment on our farms is destined to increase very greatly the sales of farm machines, for one reason alone, namely, that the increased use of tractors will make it necessary for most farmers to purchase new machines for use with the tractor in place of those which have been used with horses, even though the latter are not entirely worn out.

THE implement dealer who expects to remain in the business for any great length of time should give this matter his most careful consideration, if he does not already have the power farming vision. And it may be stated as almost a certainty that unless he acquires this vision some other dealer will soon be handling the business which should rightfully be his. This is not mere theory, but has actually happened in quite a good many cases and is quite sure to happen to others in the future. The implement dealer who does not believe in power farming, therefore, should either look around to see what is going on and get the proper viewpoint or else prepare to go into some other kind of business.

It is not meant to infer that we are going to do our farming entirely without horses in the near future. This is not at all probable. The day of the general horseless farm is certainly a long way in the future. Farmers are going to continue to keep some horses for certain jobs for a good many years to come, but this fact does not mean that they will not also use tractors. The dealer should not let himself be misguided because he feels certain that the horse is not going to be entirely misplaced on farms by tractors. This is a mistake which dealers frequently make. They look the situation over carefully and watch the results being obtained by power farmers, note that most of them continue to maintain a stable of horses, although perhaps not as large as before, and come to the conclusion that the horse is here to stay and that the tractor therefore is destined to be a failure. Some of the propaganda being spread by people engaged in the horse industry is intended to give this impression. Horses and tractors will both be used for a long time to come, but it is just as certain that horses will gradually disappear from our principal farming areas as that the automobile and motor truck have already practically driven him from the road.

THE world doesn't progress backwards. While improvements and changes come gradually, as already pointed out, they, nevertheless, come surely. Anything which increases the efficiency of man labor  
(Continued on page 13.)



One of these tractors, by its satisfactory performance and backed by a dealer who had the power farming vision, soon sold the other one.

farming vision and faith in the future of power farming, he cannot hope to enjoy as much of the business in power farming equipment in his territory as he otherwise would.

There are quite a good many implement dealers who sell tractors and other power farming machinery in a half-hearted way. Some of them have taken the agency for one or more makes of tractors without much hope that they would be able to sell very many machines. A good many of them do not have sufficient faith in the business to even purchase a sample machine. Their idea of the tractor business is to have the agency and be prepared to order a tractor in case some farmer comes to them and wants to buy one. They make no real attempt to SELL the tractors to their trade largely because they are unfamiliar with tractors and what they mean to the modern farmer. In other words they themselves have not been really "sold" on the tractor and accordingly make little effort to sell others.

The sales of tractors and other power machines made by this class of dealers are usually far from satisfactory. Such dealers are usually ready and willing to express a poor opinion of the tractor business in general. They do not believe that it is destined to amount to very much and do not see any reason why they should exert themselves to try to gain or hold a share of it.

These men are living in yesterday. They have clearly in mind the days of the early tractors and the not infrequent occurrence of an implement dealer selling a tractor which did not prove entirely satisfactory for some reason or other and on which the profit was entirely eaten up by the service required to keep the outfit in operation. They seem willing to close their eyes to the present day development in the tractor business, which is a very different proposition from that of a few years ago, until some competing dealer who has acquired the power farming vision has cut the ground from beneath their feet, as it were, and got in on the ground floor of the tractor trade for their territory. Then they realize, too late, that the implement business of the future will consist very largely in the sale of power farming equipment.

IT cannot be too often repeated that the implement dealer of the future will be a different type of business man from the one of the past. He must be a much bigger man and must handle a bigger business. The amount of capital invested in farm equipment increases each year and from all indications it will continue to grow as time goes on, which means

kind of change which is going on it really is a rapid one. Most radical changes in our modes of living or ways of doing various kinds of work occur rather slowly. It is a great deal like watching the tides build sandbars. Close observation for any short time fails to reveal much change, but by noting changes between considerable periods of time we see that large quantities of sand are being moved. Noting the changes in the kind of equipment being used on farms in any given section during one season might seem to indicate that there is really very little change taking place and that it will be years before mechanical power is generally used for farm work. However, when we think of the development which has occurred during the past five years, we can see what progress really has been made. Then, by comparing the growth of the tractor industry with that of the automobile industry, we can better realize how the use of tractors will undoubtedly increase more and more rapidly as time goes on, just as the number of automobiles used has done.

The implement dealer who cannot see this change taking place and who does not believe that the use of mechanical power for farm operations on most of our farms is to be a reality, is not the man who is likely to gain and hold a very large share of the tractor



This tractor, and the service furnished for it, helped the dealer sell two more tractors on the same farm. He likewise sold a lot of equipment for use with them.



# CANADIAN MOTOR, TRACTOR AND IMPLEMENT TRADE JOURNAL

Published on the fifth of each month by

The MacLean Publishing Co., Limited  
TORONTO, MONTREAL, WINNIPEG

JOHN BAYNE MACLEAN,  
President.

H. T. HUNTER,  
Vice-President.

H. V. TYRRELL, General Manager.

LONDON, ENG., THE MACLEAN COMPANY, OF GREAT  
BRITAIN, LTD., 88 FLEET STREET, E.C.

BRANCH OFFICES: Montreal, Southam Building, 128 Bleury  
Street; Winnipeg, 1103 Union Trust Building; Vancouver,  
314 Carter-Cotton Bldg., 198 Hastings St. W.; New York,  
Room 620, 1133 Broadway; Chicago, 405-6 Transportation  
Bldg.; Boston, 734 Old South Building.

SUBSCRIPTION PRICE—\$2.00 A YEAR.

OFFICE OF PUBLICATION—143-153 University Ave., Toronto.

Vol. II. TORONTO, JULY 5, 1920 No. 7

## Transportation Difficulties

**T**RANSPORTATION difficulties are becoming greater every day. We are surrounded, hemmed in and well nigh engulfed by the tremendous problem of inadequate transportation facilities.

Since early spring, and even before, manufacturers have been at their wits end to find a means whereby they could ship their goods. Dealers have had to cancel orders because goods ordered—and often weeks in advance—have failed to arrive in time. Some have practically been forced out of business or are at least faced with that possibility.

For some decades we have been shipping our goods by rail and have gotten so used to it that we have come to regard it as the only way.

For some years we have been riding to business, to the down-town stores and even to the country, by tram-car, and have gotten used to it so that we look on such a means of transportation as the only way.

Suddenly we are faced with a railroad strike and our goods pile up at the depots. A street-car strike is proclaimed and we walk. We talk of being at the mercy of organized labor, the big interests and any other organization we can think of at the moment. In reality we have reached the point in our civilization when a more varied and elastic system of transportation is necessary. Instead of having two great means of transportation we should have at least four.

Now that we are building solid roads we should see to it that we get the maximum amount of service from them.

The railroad and the street car form two useful and necessary means of transportation but their scope is limited. The mere fact of their being confined to a specific road bed hampers and limits their usefulness.

The motor truck and the motor bus operating on good roads will form a valuable auxiliary to the railroad and street car. It is even possible that the future will see the mobile motor bus supplant the noisy and often ugly street car.

In London, England, and in New York, street cars don't run on the principal thoroughfares. The Londoner rides all over the city in the motor bus. He finds it a speedy, safe and convenient mode of travelling. The motor bus is not an experiment but a firmly established and highly satisfactory medium in every way.

The motor truck on the highway is becoming more familiar day by day. It is considered by transport experts the world over as the great transportation medium of the future. Transportation companies are being formed to operate large fleets of trucks. These trucks in the districts in which they operate touch at every point. The smallest farmer on the most obscure route has thus a speedy express brought to his very door which will enable him to ship his grain, vegetables and fruit to market with the least delay and at a reasonably low cost.

When there is a sufficient number of trucks operating on our highways, feeding every main road and spur, we need not look on the prospect of a railroad strike with much apprehension.

*Before that day arrives, however, there is much work to be done.*

*The good road programmes we hear so much about must be turned into miles of solid road bed.*

*Truck manufacturers must be ready to supply the great demand there will be then for their product.*

*And last but not just as important, there must be created an army of salesmen and dealers educated in the truck business and able to meet every demand for instruction and service.*

## Use Your Trade Papers

**T**HE automobile and implement trades to-day are grappling with numerous problems which demand immediate solution. The trades themselves can't do very much owing to the fact that they are not sufficiently organized. Dealers are scattered far and wide over the Dominion and even though they had strong organizations they of themselves can't hope to cope successfully with all the problems.

The trade paper is designed to help the dealers. Through its pages the scattered members are brought together and held together and in a sense are form-

great problem. It is a great and an urgent problem and M. T. I. is out to help you solve it.

In this issue there is a splendid article on this subject under the caption "Stumbling Blocks in the Implement Trade" by G. H. Sallans. This story covers the ground thoroughly and we feel sure it will be read with the degree of interest it merits.

What we want to say is this, if you have anything on your mind relating to margins, credit business or any other subject, write us and we will be pleased to give your thoughts the publicity they deserve.

Don't knock!

Don't blame the Government, the manufacturer or your trade paper.

Knocking and finding fault will get you nowhere. What we want is some real constructive ideas.

You cannot surround and capture an army without a plan.

You cannot ameliorate a condition without some constructive ideas.

Well then, get busy implement and auto dealers, and put your ideas to paper and shoot them along. If we have plans from all the districts in all the provinces in the Dominion we shall soon be in a position to capture the city.

We want to help you and in order to do that adequately we must have your help.

## The Danger of Glaring Headlights

**W**ITH the rapid increase of motorization in Canada and our city and country roads becoming more and more crowded by automobiles the danger of the glaring headlight becomes more menacing.

In an attempt to solve the problem in Ontario the Provincial Government has passed a bill to compel all motorists of the Province to have the headlights of their cars equipped with approved anti-glare lenses or devices. This act comes into effect on July 19.

There are many devices on the market designed to overcome headlight glare but the universal device suitable to present conditions has yet to appear.

The type of anti-glare device which deflects the light downward by means of the tilting lamp is one that is meeting with a degree of success.

On this subject Motor Age says: "It is hoped that manufacturers of cars will give the subject of tilting lights the attention it deserves, especially in view of the many accidents occurring nightly in this country from glaring lights. Some drivers will dim their lights, others will not, so legislation will not altogether solve the problem. The lighting construction should be such that the human element can be disregarded."

## Fall Fairs

**I**N an article elsewhere in this issue the importance of fall fairs to the implement and automobile trade is emphasized. The live dealer will not pass up so valuable a means of publicity as the fair without serious thought.

Without an effort on his part interesting prospects are brought to the dealer's door.

Manufacturers and dealers in the past have profited much by the exhibition of an automobile truck, tractor, disk, washing machine, lighting plant, etc., at local fairs.

The fair time is now here; rent space and give the members of your community a chance to pass judgment on your goods and perchance make a few sales.

## Protect Yourself With Order Forms

**A**S a practical suggestion to our dealers, says "Auto Links", we would emphasize the importance of furnishing purchasing orders at all times. It is not only a protective policy for the dealer, but is only businesslike.

We have often wondered why the dealers have not (more unanimously) adopted this policy, and we have often been led to believe that we are more interested in the dealers' protection than some of the dealers themselves.

Fortify yourselves against that puny, picayune car owner who sneaks up to your desk, grabs your card or letterhead, and marches down to a jobber to get a discount. Step on him and the only way is to have a numbered order form—protect it and use it properly.



—Rally in Montreal "Star."  
Tempering the wind to the shorn lamb.

ed into one big unit. It is a medium whereby every dealer-reader can get expression for his ideas.

Occasionally we hear complaints about M. T. I. not giving sufficient space to the problems that confront the dealer.

Now this is the Editor's own page and he intends in this editorial to air his views on certain matters.

One of the complaints—or more strictly speaking the only complaint—is that we don't boost enough for the implement dealer in his fight for a better discount.

Now as a matter of fact this is one problem which we can say without fear of contradiction has been given considerable sympathy and space. Practically since its inception M. T. I. has wielded the sword for a higher margin of profit. Look back over your M. T. I. file—by the way do you file your trade papers? If you don't you had better begin now—and see how much space we have devoted to this



—Thomas in the Detroit "News."  
"City folks get themselves into the durnedest messes."



# Keep Your Eye on Rural Motor Express

THE new programme of highway improvement, recently announced by Hon. F. C. Biggs, Minister of Public Works in the Drury Government, makes it a certainty that there will be a very rapid growth of motor traffic in the Province of Ontario during the years immediately ahead. Because the motor truck is usually more economical than the railway for short hauls of not more than one hundred and fifty miles over improved roads, it can be safely predicted that a large amount of freight traffic, now passing over the railways between many points in Ontario, will be diverted to the highways and hauled on motor trucks.

A glance at the map of the highways which the Provincial Government aims to improve will give the reader some idea of the immense future of motor transportation in this province. The chief manufacturing centres will be linked together.

Notice how the proposed highway system radiates in every direction throughout Western Ontario from the large urban centers at the head waters of Lake Ontario. A recent canvass in Western Ontario showed that the majority of the industries in towns and cities would supply a very large amount of freight for motor haulage. It is not too much to say that when motor transportation has been placed on a sound basis industries will be developed which cannot now exist under the present transportation facilities.

Not only will urban centers be linked more closely but the town and country will be more intimately connected. Country people and city people will become more dependent upon each other

from an economic point of view. Business between country and city will become more direct and personal, and through the medium of the motor truck a better understanding of each other's problems will be likely to arise.

The motor trucks which confer this distinct social advantage may be owned either by individual farmers or by men operating the rural motor express routes in productive farming districts as a purely business enterprise.

IF the motor truck salesman be wide awake he will know the conditions under which rural motor express will pay and he will study the rural districts for the purpose of selling trucks to persons whom he may be able to interest in the question.

What are the essentials of the economical operations of rural express? Certain important underlying factors must be considered. These factors fall into two general divisions--(a) the volume of business, and (b) the external conditions which have a direct bearing on the business.

(a) A motor express business depends for its existence on the tonnage carried. Speaking generally, the profits of a route will vary directly with the tonnage. The greater the prospective tonnage the greater will be the profits.

However, the total quantity of agricultural products moving from the territory under survey is not an entirely accurate guide for the prospective truck operator. The truck operator in a district producing grain exclusively, who has offered to have a greater tonnage that it is possible for him to carry during September and who has very little freight to haul during the other eleven months, is likely to fail. The ideal territory is an area in which not only the total productivity is large but the products move to market

By D. R. COWAN, M.A.

Investigator of Rural Motor Transportation for the Ontario Department of Agriculture

in a fairly steady stream throughout the year. Dairy and truck farming districts and areas of intensive but diversified agriculture have proven to be the most profitable for the early development of rural express.

The character of the tonnage to be moved is also important. Low-priced, bulky staples, such as hay, will not usually bear the motor truck rate. On the other hand, perishables which must be moved to market promptly if deterioration is to be avoided, may readily bear a motor express rate because of the speedier service obtainable. Light, bulky products require an undue amount of space and may prove unprofitable as a load. In general, loads which have a high value per unit of weight and bulk offer the most profitable return. These considerations are important because on them the salesman should base

ordinary tonnage will not enable an operator to make a profit.

Existing transportation facilities deserve attention. To offer a motor express service in direct competition with established carriers who are satisfying patrons, might show lack of judgment. If, however, the motor truck can make marketing more direct, can move perishable products more speedily, or can offer a more complete pick-up or delivery service, it may be possible to establish it successfully as a supplement to the older carriers. Special attention should be given, therefore, to the schedules, collection and delivery arrangements, and rates of existing carriers. No rule for fixing the motor rates can be set forth in advance, but if it becomes apparent that the rates by motor truck are going to be much higher than other local rates without a corresponding increase in service rendered, it is obvious that no permanent business will be secured.

When the salesman is certain that the truck he is endeavoring to sell will be a paying proposition in the light of local conditions, he will be able to ad-

vance his arguments fearlessly. He will also be able to present to the prospective buyer the advantages of rural motor express, and the operator may in turn use them in advertising his business throughout the rural community.

These advantages or benefits may be enumerated:

(1) It will tend to intensify agriculture and is itself an example of specialization in industry.

(2) It may encourage diversity in farm

production by widening its market areas.

(3) Men and horses hitherto mostly engaged in driving to markets may be employed on the farms.

(4) It may provide a means of marketing food products, formerly unavailable because of the distance between the farm and the market.

(5) Speedier transportation of food to the consumer will be accomplished.

(6) Perishable products will be marketed in better condition because of the rapid transit.

(7) In all probability the farmer will be enabled to take advantage of a specially high price for produce of which he has an insufficient quantity to make it profitable to market individually.

(8) Supply may be made elastic, and as a consequence the reduction or elimination of violent price fluctuations will benefit the whole community.

(9) In place of the disinterested and impersonal relations with, and the limited liability of the railroads, it will substitute on short hauls an agency which personally collects and delivers produce and performs both marketing and transportation functions.

(10) It must eliminate much handling and special packing of produce involved in shipping by railway.

(11) It will inevitably serve as a feeder to railways and steamships.

(12) It may make possible the establishment of a more direct connection between the farmer and the consumer by eliminating some middlemen.

(13) By reducing the cost of marketing it is likely to make possible a reduction in prices.

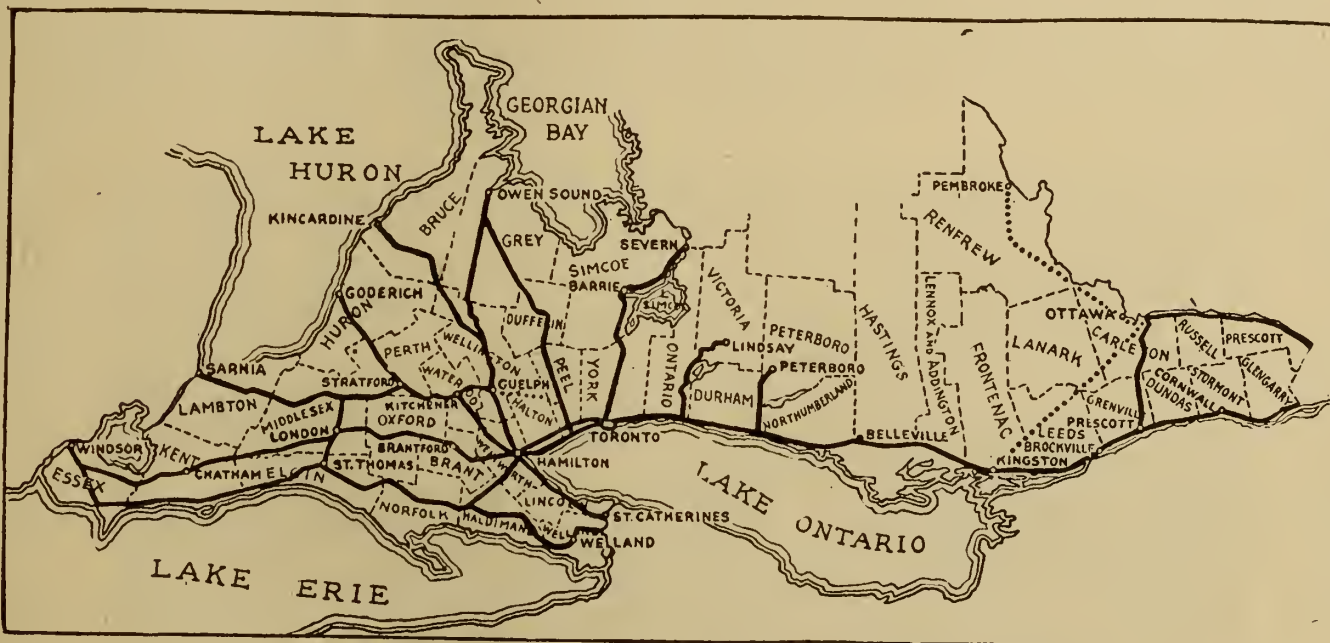

A map showing in a general way the roads that become Provincial Highways in Ontario.

his decision as to the size of truck and type of body to be sold to a prospective buyer.

Although rural express routes may be developed for the purpose of affording more adequate transportation facilities for agricultural communities, it does not necessarily follow that loads should be confined entirely to agricultural products. In many cases, tonnage furnished by small industrial plants, country merchants and city dealers with a rural clientele, has made possible the profitable operation of a motor express route established primarily to serve the farming community. Such freight is highly essential because it will bear a higher rate than farm produce. Few farming districts can support a motor route with a tonnage of farm products only, but other tonnage should be obtainable in the small towns and villages between the termini.

THE possibility of obtaining return loads should not be overlooked. Usually a motor express route cannot exist entirely on a one-way load. Here again the operator must establish contact with commercial shippers who may provide loads in both directions. As a rule, country merchants provide a considerable part of the load coming from the city and the importance of this business cannot be overlooked.

(b) Among the external conditions directly affecting the business, roads are a prime consideration. The salesman as well as the prospective operator should know what territories the roads serve and where they connect; whether they are paved; the kind of pavement and its condition in wet and dry weather; the grades; and the traffic conditions at different hours on different days of the week and at different seasons of the year. If these conditions are unfavorable, operating expenses may be so high that



# Stumbling Blocks in the Implement Trade

WHAT hopes has the implement dealer of ever doing business on a strictly cash basis? Will the time ever come, or is it part of the millennium, or has it anything to do with millenniums? Certainly, it is akin to the ideal condition, and they say the ideal is never quite reached.

Right at present, it must be admitted, there are tremendous difficulties in the way of such an adoption. There is a certain amount of psychology connected with it, a large amount of the human element, much tradition, and a brutal proportion of hard fact. The first named is essentially first, for analytical, or introspective psychology, involves a description of the mental processes as they are immediately apprehended, and, therefore, has its direct bearing on the other three elements, two of which are characteristics, and one of which is the result of mental processes.

Therefore, it would appear that a practical application of the first to the other three would solve the difficulty, wash out the credit fog, and establish the dealer in a new light in his own, the manufacturers' and the public's eyes. But it will not. The education has to be taken reversely, from the hard fact back to the psychology. Then you get somewhere, by evolution or revolution. By starting at the root of things, analyzing it as you go, admittedly you climb, but after you've swept away a lot of the difficulties and think you're on the way to the opening, you suddenly find you've climbed up the inside of the pyramid, and all your reasoning, through the different stages of which you have fought, lies beneath or behind you, spread in the four ways, and availing nothing.

NO amount of psychology, for instance, will get away from or around the fact that to-day the dealer is up against the consignment contract in 90 cases out of 100 of manufacturers, that he can't sell on a cash basis without some change, both within himself and within the manufacturer, and that even as it is he's operating on approximately a ten per cent. margin for most of his implements, while his overhead is 18 per cent. and going higher. These are some of the things that a psychological application would reveal as existing, just as the Board of Commerce discovered that there

was a sugar shortage in the West several months after this became painfully apparent to every housewife, but it would suggest no possible means of adjustment. Therefore, the hard facts have to be considered and applied to the problem in hand.

And that is just what is being done by the retailers in the implement world of Saskatchewan. First, realizing that an ounce of fact is worth a pound of theory, they have a special representative in their association office collecting data from far and near, specific cases by the score, to back their arguments when they again meet the wholesalers and manufacturers. Faith will move mountains, but it takes proof to move men.

First, the dealer is up against the fact that his margin has shrunk, in spite of him, from 20 per cent. and more in 1914 to 10 per cent. and less in 1920. On some implements it is six, on others higher. But there you are, and his overhead, economize as he may, averages around 18 per cent. In the States, the implement States, of course, it is 17.44 on an average. It is estimated, and granted, that eight per cent. is a fair profit over and above cost of purchase, and doing business.

WHAT is the result? They're all going in for something else. They have to—and make implements a side line. But that is a sub-normal state of affairs, and should not be. And as for cash business, why it should be, and what it should be. A mail

By G. H. SALLANS

order house buys direct from the manufacturer at the jobber's price, and delivers, say, a set of harrows, at \$36.50, where the dealer has to pay \$35. But if the dealer tries to cut out the jobber and get his stuff direct, he pays the jobber's price just the same. In other words, we're both going along a road. You have a straight road, no bends or rises, on your side. On my side I have obstacles, a little rise, a stile, and a toll gate half-way along. You get home first, yet you're not so tired as I. You have expended less, and got there first. That's the way with the mail order house, and the co-operative association, buying direct, while the other fellow stops at the toll gate.

They say the percentage of wholesale contracts has decreased because it was hard to get dealers strong enough financially to handle goods under such a contract. Therefore, the consignment contract has stepped in, and the dealer's chances for even competition have stepped out. They had to give credit to get these men started, so, as they couldn't do that, they let the dealer give the credit and they dealt in cash. That was all right. It was good business, for all but the retailer, who found himself just about 60 per cent. out of luck as a result. From that discovery, the wholesale contract took a slump in popularity, until now at least 90 per cent. of the manufacturers

per cent., but this year, though it shows another slight increase, the dealer's overhead has increased alarmingly. The retail price is now \$284; landed cost, \$253.75; and margin, \$30.25, or 10.78 per cent. These figures are based for an average point in Saskatchewan, and the average freight to that point from Regina up till 1918 was 25 cents a hundred on carload lots, and since that year 30 cents.

A certain make of double disc drill tells the tale still more convincingly. In 1914 the retail price of this drill was \$140 and the landed cost \$111, leaving a margin of \$29, or 20.71 per cent. To-day the drill costs the customer \$257.50 retail, landed cost is \$231.75, and the dealer's margin has shrunk to \$25.75, or 10.00 per cent. of the sale price. This in face of the well-recognized fact that his overhead has jumped to almost twice its former figure. The shrinkage might well be noted from year to year. In 1916 it had gone down to 15.13 per cent.; in 1917 it was 14.28 per cent.; in 1918, 11.26 per cent.; 1919, 10.68 per cent.

In considering these facts it must be remembered that careful estimates show the overhead averages around 18 per cent. for all retail implement dealers, and while the wholesalers claim their overhead has jumped, it is reasonable that the retailer's overhead has also taken a leap of some sort.

Then there is the question of repairs, which must be handled by all retail dealers, if they wish to

shine as dealers. For mail order houses fill only a part of the implement business, and when it comes to the odd bolt, or the plow share, or the hundred and one little things that the implement user needs almost every day, it's the dealer who supplies, and works overtime in doing so. From the time he sells a binder, or a plow, or whatever it is, he is continually supplying something for it. In the first place it costs him \$7.50 in actual terms of work alone to set up a binder. This is taken out of his margin, of course. But his repair department turns in, and from then on it becomes a matter of service where service is demanded. It is not really business. His turnover, on the average, in the repair business is once a year. Take away his plow share business, and his turnover

would be once in three years.

There is another factor in the repair business, which is very obvious to the dealer himself, and that is the smaller the article the smaller the profit. That is, he makes far less selling ten things for ten dollars than he makes selling one thing for the same figure. It often takes him an hour to sell one little contraption that probably costs 35 cents. On this he probably makes five cents. On the other hand, he could sell a self-respecting binder in that time, possibly less.

As it stands now, also, the wholesaler, supposing paper is turned over to him by the dealer in October, for a plow that was sold in May has six months in which to turn back the note, if he finds it's of no use to him. The dealers want this cut down to 30 days, and the nearest they have come to it yet is a conditional compromise that it may be cut down to 60 days. In other words, it means that the buyer has a year or more to get away or do anything he likes after he makes his purchase, and the dealer when it finally comes to him to collect, is under a distinct disadvantage. He cannot foretell in October what the financial condition of the farmer will be the next May. But he believes that if the wholesaler can't find out in two months, or one month, whether paper is any good, he won't find out in six, under the system he employs.

As an illustration of the implement situation, taken by itself, it is interesting to note that the United



A New Jersey farmer pulling four 14-in. bottoms with a 12-20 Advance Rumely tractor in very light soil.

deal with the wholesaler, and the retail man gets his stuff by consignment contract. If that was extended to all, mail order houses and such, it would be even chances for all concerned.

All these circumstances are covered by an insufficient margin, together with several other factors, which are steadily growing worse for the dealer, including the cost of doing repair business, which is out of all proportion to the worldly gains derived therefrom, and the length of time, six months, which the wholesaler is allowed to turn back what he finds out to be bad paper, turned over to him as collateral by the dealer.

Take these things in turn, the margin first. The dealer here finds himself up against the groundwork of all his troubles. It has always been so, of course, since the start of mail order business and co-operative buying, but it is worse now than it has ever been before.

IN 1914, as one instance, a certain well-known binder cost \$170, retail. The landed cost to the dealer, including \$14.50 for freight and dray charges and \$127 factory price, was \$141.50, leaving the dealer a margin of \$28.50, or of 16.76 per cent. In 1916 the selling price of the same binder was \$178, landed cost \$152.50, leaving a margin of \$25.50, or 14.30 per cent. In 1918 the retail price was \$259; landed cost, \$232.50; margin, \$26.50, or 10.23 per cent. In 1919 this margin grew slightly, to \$26.25, or 10.63



Grain Growers of Saskatchewan lost just \$60,000 on their machinery department alone in 1916—this, in spite of their co-operative buying on wholesale contracts, which shows what the dealer is up against who has not that privilege. But the Grain Growers contend that five or six years ago the price of implements in Canada was no lower than it was in the States, and claim that their movement was responsible for the reduction on this side of the line.

The overhead of this association, as with mail order houses, was much lower than the strictest economy would allow the garden variety dealer. The wholesale contract enabled them to get implements from the manufacturers at the factory price plus duty, freight, and dray hauling, while the dealer competing with them, and wishing he could do so on a cash basis, paid all these, an overhead and profit for the jobber, and higher freight rates through getting smaller quantities. Of course, the jobber must be protected until it comes to a concern which handles just as big orders as even the jobber himself, and then the consignment contract is the engine, and the retailer pays.

As for the prospects of a cure, they are as yet clouded, but association work in the province is growing stronger every day, and the rumbling of the brotherhoods is being heard to take on a quicker pulsation, with a tenser note. The implement men have their own section in the Retail Merchants' Association, and this summer they are convening in Moose Jaw, June 8, 9, and 10. There the whole matter will be gone into and a joint meeting will

then be held, for the feeling between the wholesalers and retailers is by no means inimical. On the other hand, it has been very friendly, and the wholesalers have rather shown a desire to improve conditions wherever possible, so that it is only a matter of time and organized effort before the cash business will become an accomplished fact, and the margin be again widened to a living basis, so that the implement business will come into its own as a separate entity, and not as a side line, to which classification it is ruthlessly ruled to-day by the prohibitive aspect of the profit and loss account.

Several prominent implement men have given this as their opinion already, and they are quite as eager for it as the retailer himself, for they realize what the implement industry should be and what the distributing business should be. They also realize that the last straw will break a camel's back and that psychology may, after all, have something to do with fish, and that in the rebound they may be left behind. Right now, when co-operative buying is coming into prominence, is the greatest opportunity the wholesalers and retailers ever had of getting together and figuring out a working basis, whereby the service can be given which will equal co-operative service. It can be done, and will be done, or the prospects of the present are not what they appear to be.

**B**OILED down in resolutions, the situation as presented at the last meeting between the retailers and wholesalers, before the year 1920 was ushered

in, with its new developments, was that the average cost of doing business, based on figures supplied by dealers, is 18 per cent., that eight per cent. is a fair profit; and that the tendency to do away with the wholesale contracts is to be deplored, and that there should be a spread of at least five per cent. between the invoice price of wholesale and consignment contract, with the same cash discount.

A common charge of the other interests is that incompetent men with incompetent methods are in the implement game on their own, and that, until better show systems are adopted and books kept on a better basis, the conditions must remain as they are. But if it is true that the better men are out of it, the reason lies in the narrow margin, and psychology does the rest. As for the bookkeeping methods, these can be looked after, and new systems are being worked out right now.

At the convention this summer a system will be illustrated whereby three separate sets of books will be kept: big implements, small implements, and miscellaneous. This is because of the difference in margins on the three classifications, and will enable the dealer to find out where he stands, on what articles of agricultural furniture he makes the easiest money, and where he can improve on the old. Taken by and large, the situation is not so bad as it might be. The war has broken up traditions in other things, and it has paved the way for a breaking up of implement traditions. Organized action will do the rest.

## Are You Getting the Farmer's Viewpoint?

**T**HE implement dealer is in business to make money. And the amount of money he makes is dependent principally upon the volume of farm implements, repairs, and binder twine that he sells. Naturally, therefore, his goal is a large, steady volume. The point is, how shall he go about achieving that volume and maintaining it?

Foolish question to ask an implement dealer, isn't it? Every dealer knows that a large volume is a matter of salesmanship, advertising a good line of favorably known implements for which there is a demand, a prosperous farming community for a selling field, and the absence of destructive competition. But there is one little thing that some dealers seem to overlook and upon which a STEADY large volume hinges—THE MATTER OF GETTING THE FARMER'S VIEWPOINT.

Quite a few implement dealers are retired farmers, or farmers who have forsaken the farm to sell implements to farmers. These dealers certainly ought to have the farmer's viewpoint. But apparently they forget—or shed their old viewpoint for an entirely new one when entering the new line of endeavor. Some farmers are retired implement dealers, or dealers who did not make a success of selling implements because they did not have the farmer's viewpoint. Through personal experience, they learn it too late. And still, there is nothing mysterious or difficult about getting the farmer's viewpoint. Not getting it is just a matter of being so close to your own business that you don't see the other fellow's.

There undoubtedly are quite a number of implement dealers who consider themselves "live wires"—aggressive, up-and-doing fellows—who have adopted as their sales motto: "Go after your prospects hard, stay with them until they're sold—and sell 'em all you can." For a temporary large volume—a spasmodic flurry of prosperity—this rule should be effective. But the farsighted dealer who considers carefully the farmer's viewpoint works on a plan of action something like this: "Go after your prospects hard, stay with them until they're sold—BUT BE SURE THAT THE CUSTOMER HAS A REAL NEED FOR THE MACHINES YOU SELL HIM, AND THAT HE IS IN A POSITION TO PAY FOR THEM."

**T**HAT, in a nutshell, expresses the matter of getting the farmer's viewpoint—the little "nigger in the woodpile" that so many otherwise progressive dealers have a tendency to overlook. This business of trying to get all that the traffic will stand, which is a quite general modern tendency, is mighty poor business for the man who expects to be doing business at the same stand some years hence. And yet,

By B. J. PAULSON

that's just what the implement dealer is doing when he sells a tractor to a farmer whose farm is too small to make a tractor a paying investment for him; or who sells a new binder to the farmer who can make his old one do just as well for a few seasons more by investing in a few repairs. This dealer is not helping along the farmer's prosperity nor building up the customer's good will. And because he is not doing this he is not building up his own future prosperity.

The implement dealer who makes it a point to know the real needs of his customers and advises them to the best of his knowledge and ability as to the new equipment that will prove advantageous, is laying a solid foundation for future business. He has the farmer's viewpoint. He puts himself in the farmer's place and does not sell new equipment to the customer merely for the sake of the sale. He takes into consideration the practical value of the article to the farmer. He puts himself in the farmer's place and analyzes his needs.

This does not mean that he does not try to sell a good volume of equipment to his customers. On the contrary that's just what he DOES do—if the farmer is financially and agriculturally able to handle it. He discovers the many loopholes in the average farmer's equipment—loopholes through which valuable time and more valuable crops are unnecessarily escaping. He then makes it a point to point out these loopholes to the farmer—and shows him how he can save time and increase the working capacity of both man and horse labor on the farm by investing in the proper equipment. It's just a case of intelligent salesmanship instead of "hit or miss" selling. The farmer who buys equipment that proves a real asset instead of a liability, by so doing places himself on an operating basis that will result in increasing his future buying volume through increased prosperity and efficiency. He is inspired with a greater confidence in modern time and labor-saving equipment.

**A**ND next in importance to selling the farmer the right equipment is the matter of after-sale service that will keep such equipment in good working order. The dealer who gets the farmer's viewpoint appreciates the importance of carrying on hand a sufficient stock of repairs to meet the seasonal requirements of his customers, and the necessity for being able to render expert service. Frequently repairs or adjustments are necessary that the farmer cannot make properly himself. The dealer should be sufficiently familiar with the implements he sells to be able to help the farmer out. By giving his

customers prompt, efficient after-sale service he makes every sale of an implement pave the way for another sale. In this way a steady, dependable sales volume is achieved. It isn't the immediate results that make an implement business but the cumulative results extending indefinitely into the future.

The foresighted dealer who considers carefully the future, therefore, builds his business structure upon a solid foundation of satisfaction to the farmer, which rests upon the basic bedrock of getting the farmer's viewpoint. The dealer of lesser vision, however, who sees only the immediate present and CONSIDERS THE FARMER AS MERELY A RESERVOIR INTO WHICH TO POUR FARM IMPLEMENTS AND PUMP OUT DOLLARS, builds his business structure upon a precarious foundation that rests on the loose, uncertain sand of unprofitable service and dissatisfaction. It pays to get the farmer's viewpoint and to observe the Golden Rule to the extent of selling to the farmer as you wish to be sold to if you were the farmer and he the implement dealer.

### Have You the Power Farming Vision?

(Continued from page 9.)

and reduces the expense of production, no matter whether it is the production of crops or of some manufactured article, will eventually be generally used. The tractor does both these things. And furthermore it offers the opportunity for the human race to issue an emancipation proclamation to one of man's best friends who has served him in bondage for centuries—the horse. And the horse's bondage has been no light one—from youth to old age, in sickness and in health, in good weather and bad, the horse has been required to wear the heavy work collar, toiling often in great pain and under inhuman abuse, at work which can now be done better, quicker, cheaper, and far more humanely, by the farm tractor. Some selfish interests may endeavor to prevent the casting off of the bonds which have made the horse the slave of man, but right and justice will prevail even for the work horse, and he will gradually be released by the motor-driven, man-made machines.

And with his passing we are entering a new era of agriculture—an era which will be marked by the same efficiency in food production which we now have in our factories. And the man who will play a great part in bringing this result to pass, and who will profit accordingly, will be the implement dealer who has acquired the power of farming vision and who will preach the gospel of efficient farm machines to his customers, to their mutual advantage.

Have you the vision?



# DETAILS IN STORAGE BATTERY SERVICE

## Article No. 3—Taking the Battery Apart

By A. M. GLOVER

Battery work is becoming an important and necessary business with the modern garage man. It is a branch which he cannot ignore, especially since the Ford car is being equipped with a starting and lighting device. The articles in this series are planned to help our dealer readers get a real grasp of battery repair in all its phases.

The first two articles dealt with general details and testing of the battery. The present article describes how to take a battery apart and gives some valuable points thereto. The next article will take up charging, assembling and general repairs.

the edges can then be lifted or scraped out with a narrow chisel kept warm by means of the torch. Remove as much of the seal as possible and once more give the tops a good warming up with the torch.

If a steaming outfit is installed splendid results can be obtained. In this case all the electrolyte is poured out of the battery and a rubber hose inserted in the vent holes through which live steam is forced into the battery. The steam will warm up the whole outfit and little danger of breaking the hard rubber parts will be experienced. Having removed the seal and warmed up the cell covers, now place the battery on the floor and take a firm hold of it between the feet, or better still, make the holder shown in the cut.

With two pairs of pliers take a firm hold on the portion of the posts projecting above the covers and lift on both posts at once. If the covers are warm and the seal removed, the complete set of plates and covers will lift out. After removing the plates turn them at an angle in the top of the battery as shown in the cut and leave them to drain.

After the groups have drained for some time they may be taken out of the jars completely and placed on glass. Do not place them on any wood or metal for the acid still in them will eat into the wood, and if placed on metal the acid will cause a short circuit between the plates and ruin the group.

We now have the battery box with only the hard rubber jars containing the acid. Turn the box upside down on your lead sink and let the acid run into a receptacle. It can be used again if strong enough and if it isn't it can be brought up to strength by the addition of more acid.

When this has drained for a while it will be found that there is some sediment in the bottom. The quickest way to get rid of this sediment is by flushing it out with the water hose.

Flush it thoroughly and allow it to drain dry, for we do not want anything but pure distilled water in it when it is reassembled.

WE will suppose that, even though we only intended to clean out the sediment, we find on examination of the groups that new separators or plates are needed; it will be good policy to put these in for the little extra cost involved.

We shall now proceed to separate the positive from the negative groups of plates. The cell cover comes off first. It must be softened by heat, and if the posts have nuts and rubber washers these must be screwed off, but most of them just slip over the posts. Get the top warm, then grasp the group in one hand and the top in the other, move the groups sideways until it is loose, then lift straight up and

you have the group without the top. The next operation is to get rid of the separators. This is easily done by grasping a post of each group in each hand and working them until they can be pulled apart. The separators will then drop from between the plates. As the separators can't be used again, scrap them. If on examining the plates the composition is found to be loose and falling out, or the plates buckled, they should be replaced with a new group. Do not try to put in one new plate, for if one of a group has gone the others will soon go. It is poor policy to risk having to tear down the battery again through trying to save the small cost of a few plates or separators.

The negative group will be found generally in the better condition of the two; but examine it closely before passing it as good.

If you find the plates covered with a white lime-like covering, this is sulphate, a substance which renders the battery very inefficient. Plates

in such condition should all be replaced as no certain cure so far has been found for sulphated plate. Even if you put in new positives and the negatives are sulphated, the battery will not be in A1 condition.

THIS gives a general outline as to the operations necessary in tearing down batteries, but the construction of the different makes varies. For instance, on one model U. S. L. battery the cells are placed end

Continued on page 38

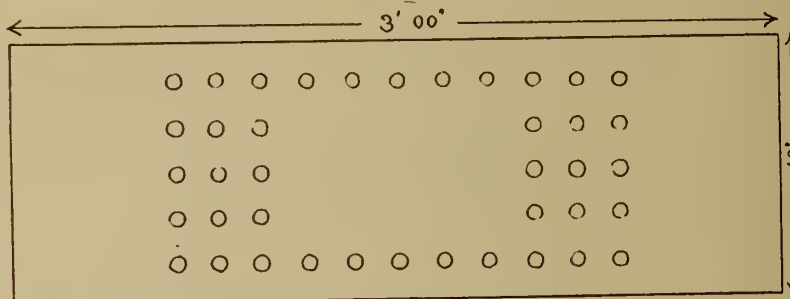
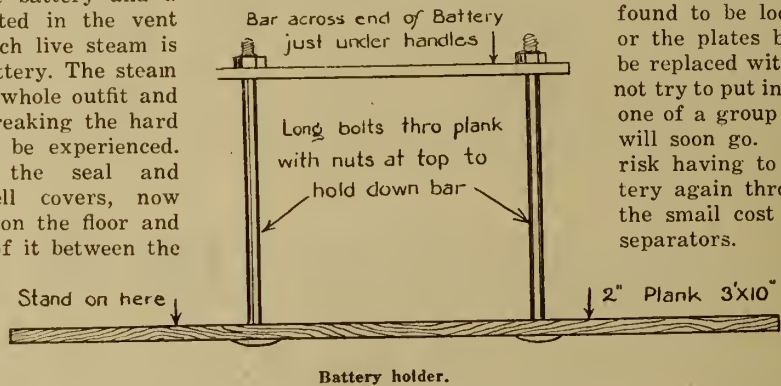

Holes drilled to take Pins in positions to fit different size batteries  
Plan of battery holder.

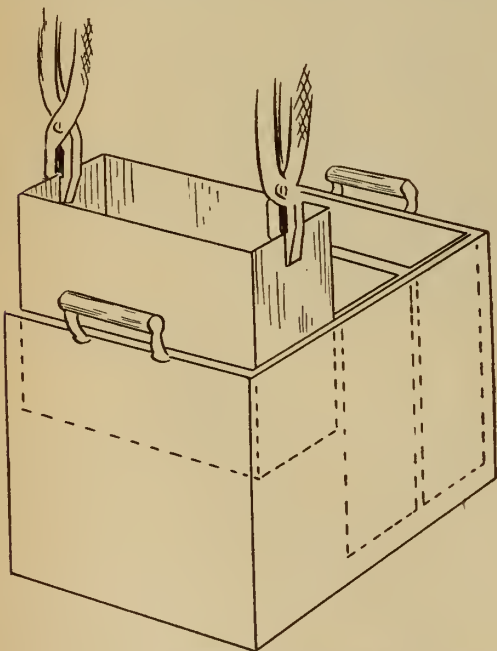

Grip the jars at the narrow ends firmly, as shown, and lift steadily without jerking.

to take plugs on the cable, these may have to be removed also. To do this, take a 3-4 or 5-8 drill, according to the size of the post, and drill down the centre of the post about 3-4 of an inch. This should leave about 1-8 of an inch of lead all around the hole. By this means the cell post is removed and the connector may be lifted off. If it sticks a little, through not being drilled quite out, by moving it a little from side to side or by applying the lead burning torch to the inside of the hole at the bottom, it will be found to come quite easily.

We now require to lift out the groups, and we will do this with the tops (cell covers) in place. Take a small acetylene torch and heat the hard rubber covers until they are soft and pliable. The seal around

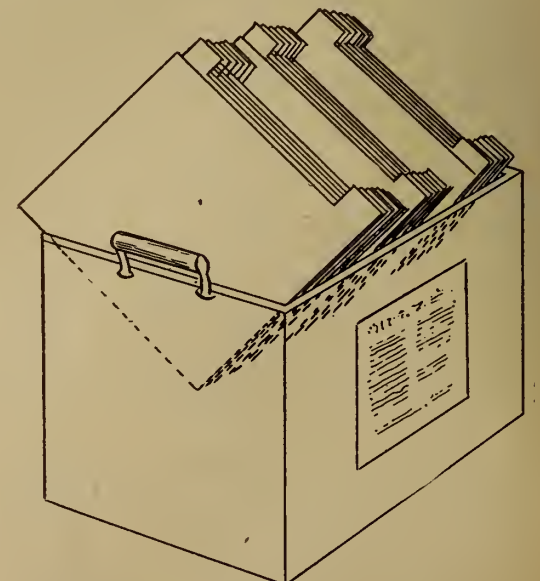

Groups lifted out of jars and placed in position to drain.



# Good Roads Convention at Winnipeg

## Importance of Good Transportation Facilities Emphasized. Motor Truck and Paved Roads Give Boost to Production

FROM the fishing grounds of Newfoundland to the fishing grounds of British Columbia, and from all the provinces in between these two extremities, government and municipal representatives gathered in Winnipeg on the opening day of June to take part in the seventh annual Canadian Good Roads Convention. There were highway ministers and deputy ministers, engineers, farmers, business men and motorists anxious to learn the latest information regarding road building and maintenance.

In the west the earth and gravel road will for many years be the only thing possible, and the delegates discussed ways and means of extending their present highways in the most economical and efficient manner. There was no need for anyone to tell the men from the West that a country without highways is like a house without windows—they knew that and sought merely the solution of the difficulties of the prairie clays and the gumbo soils. And it is safe to say they went away with a lot of valuable information which will give a fillip to road maintenance in the future.

There is one mile of road for every 22 of the population of Canada, for there are 350,000 miles of roads in the Dominion, although many of them are little more than prairie trails. But they are a beginning, and the lesson that the delegates took home with them, above all, was that they must strive to do the best they can with the material nearest at hand, being assured that with constant day to day attention they can not only maintain a good road almost indefinitely, but they will be building up a foundation ready for more permanent types of highway when they are needed.

The keynote of the convention was struck by the Hon. S. J. Latta, from Saskatchewan, when he said that the essence of British patriotism is to be found in the home, and that if the problems that confront the Dominion are to be solved it must be by giving attention to the home and making it attractive by giving proper facilities for communication and transportation.

The people of the West realize the value of roads, but they are faced with the triple difficulty of lack of money, labor and suitable materials. They are prepared to spend money for roads as witness the people of British Columbia who are going to spend a million dollars to blast a road ninety miles long through the rock in order to open up a fertile country. In Saskatchewan also they are making efforts to punch a couple of roads to the north for the same purpose. From other provinces come the same story—Quebec is preparing to spend another \$17,000,000 in the next five years to add to its \$26,000,000 system of present highways.

THE Farmer Government of Ontario, ably represented by, among others, the Hon. F. C. Biggs, Minister of Public Works, and the Hon. B. Bowman, Minister of Colonization, is extending its provincial highway system from 422 miles to 2,000 miles, and it was evident there were no more enthusiastic supporters of good roads movement than the farmers. They aim to link up every county town with good roads, and the Hon. Mr. Biggs emphatically declared that it was only a matter of another year or two till every farmer was going to be an automobilist in his province, driving not only a pleasure car, but the owner of trucks, because they had come to realize that for the short haul, probably up to 50 or 60 miles, the quickest and most dependable way to place their products on the market in first class condition was by the rapid transportation of the motor truck. He looked forward to the time when the Federal aid for highways would be \$100,000,000 instead of \$20,000,000 for five years, declaring that all money honestly spent on road improvement was a paying investment.

The Hon. Mr. Biggs emphasized the need of greater production through the use of higher class machinery on the farm, and showed how with the motor truck the farmer on a good road could save

over 200 per cent. of the time he now used in hauling his produce over a bad road.

The president, S. L. Squire also spoke during the convention on what the good road means to the farmer, in that the average cost of hauling produce per ton mile was cut down by practically half. From A. P. Sandles, of Columbus O., came the declaration that the convention was the engine room and power house for a greater Canada and that commonsense road building was a national necessity. Furthermore he maintained the time was coming when road builders would insist on special equipment for loading and unloading road material and reduce the time it took in manpower to transport material.

INTERESTING papers on the most modern kinds of road machinery, tractors, levellers, scrapers, graders, drags, etc., were listened to with the closest attention, and the demonstrations of road dragging

just outside Winnipeg were attended by at least fifty per cent. of the delegates.

Particularly valuable papers and addresses were given by A. R. Hirst of Wisconsin, who has a patrol system of 900 men each looking after about seven miles of earth road, eight months in the year, with about 25 sections in which tractors are used; by the newly-elected president, A. E. Foreman, chief engineer for the province of British Columbia on the organization of provincial highway departments; Deputy Minister H. S. Carpenter of Saskatchewan, on road dragging and maintenance competitions; and many others.

The Canadian Good Roads Association has been put on a firm basis with a growing membership, and its affairs will be managed by representative board of directors from each province and by an executive of which S. L. Squire is the chairman, and George A. McNamee, of Montreal, the very efficient secretary.

## Value of Fairs to the Implement Trade

By W. A. PRUGH

SPRING with its arduous task of sowing has gone and the crops are advancing rapidly toward maturity. The farmer is again pausing for breath and marking time until the strenuous days of harvest come. Flies, lawn mowers, ice cream sodas, "swimming holes," hot weather, base ball games, gardens, coca-colas, lawn socials, holidays, mosquito bites, and fairs are again in fashion, and Johnny Canuck is making the most of his opportunity to enjoy himself before the season of "all work and no play" is again upon him. It is safe to presume that as usual he will dress up in his best—pack the family into the Ford or McLaughlin six as the case may be, and drive to the Fair, taking care to have the "woollen string" wrapped tightly around his wallet lest the sharpers make inroads upon his bank roll.

Johnny Canuck does go to the Fair. Record crowds to all the large Western Fairs proves that it is still a great attraction. What does he go to see? The horse races, the bright lights of the midway, the airplane flights and other amusements come in for a certain portion of his attention, 'tis true, but a stroll around the grounds finds him also interested in the stock and machinery. He goes to see for himself the products advertised in the farm journals and looks over the cars, the trucks, and the tractors before he places his order.

From the standpoint of the manufacturer and the dealer, let us view it without colored glasses—in fact, turn on the spot light so that the advantages can be seen.

Fairs are a great meeting place. From every corner of the Province they have come—manufacturers, salesmen, dealers, and farmers, and the most encouraging part of the whole situation is that they

take the time to look things over, and discuss the merits of each article. The manufacturer of a new line has his best opportunity of presenting his product to thousands of interested people each day. Compare the expense and effort of making the same number of calls and covering as wide an area with the opportunity of exhibiting at a Fair. It is the greatest place imaginable to introduce a new product. The old established firms have the opportunity of meeting their old customers and their dealers, and their reappearance each year is conclusive proof of their reliability and stability.

Rivalry, friendly rivalry, exists no doubt, and occasionally a salesman forgets himself and starts to use the hammer, but "knocking" is not common at the Fairs. A product has a chance to be sold on its merits—the buyer has a chance to look them all over and draw his own conclusions.

FAIRS are often condemned because of the prominence also given to fortune tellers, side shows, and various forms of amusement, but the real value should not be overlooked because of this fact. After all, "A little gaiety now and then is relished by the best of men."

"Machinery Row" as it is usually called is always alive. The smoke curls upward from the steam threshers and the gas tractors purr away all day. Here and there is heard the "pop-pop" of the exhaust of a stationary gas engine operating a fanning mill or cream separator. Further along a lighting plant is in operation, and a blaze of light illuminates the booth. The noise is almost as apparent as the blare and clamour from the midway. The machinery is operated. Not only displayed for inspection but being put through its paces. "Action" is seen everywhere.

The three links in the chain of industry are here gathered together. The manufacturer, the dealer, and the buying public. Business only results from a close co-operation of the three, and I am safe in saying that a great stimulus is given to business immediately after these fairs. The three have been in touch with each other.

The manufacturer who fails to exhibit is losing a most valuable opportunity to show his goods.

A dealer who fails to attend and bring along his best prospects is losing his opportunity of the co-operation afforded by the manufacturer.

The farmer who stays at home perhaps has saved the money he would have spent on pink lemonade and a few side shows, but he has missed his golden opportunity of seeing for himself all the latest improved machinery, and in this day and age new products are coming in the market so rapidly that he should not neglect the advantage afforded him in this respect.

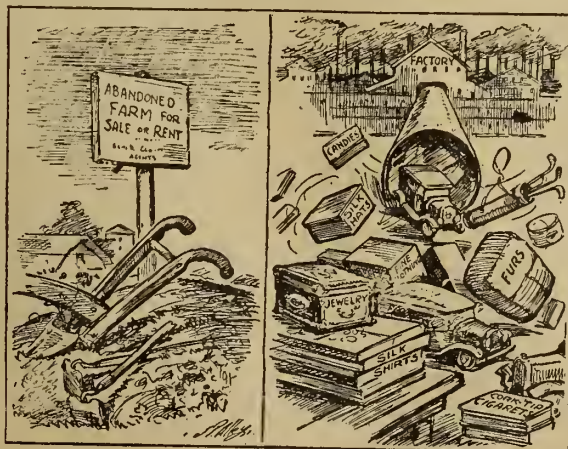

PROSPERITY!"

—Alley in the Memphis "Commercial Appeal."



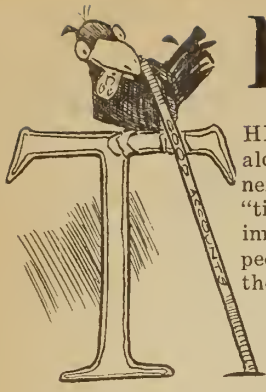

# Planning for the Fall Campaign

By B. J. PAULSON

THE days are marching right along now, with fall as the next objective. And, as usual, "time waits for no man." Every implement dealer, of course, expects to take an active part in the fall campaign, but it isn't every dealer who takes the time to pause long enough in the midst of harvest selling to formulate a systematic plan of action.

"Time enough to think about selling machines and implements for the fall trade when the fall season rolls around," may be a popular slogan among a certain class of dealers, but it certainly isn't the kind of a slogan that will help to increase the fall sales volume. It's the lazy slogan of the procrastinator—the fellow who is always putting off something until tomorrow or the next day. And when you come right down to cases, we all belong to that class to a certain extent. Sometimes it's mighty hard to seize Time by the forelock and harness her to a job that we know ought to be done right away but which we feel inclined to put off because of matters that seem more pressing, which require immediate attention. And so we keep on putting off until at last we discover that the job about which there was no hurry at first has become all important—and no time available for handling it. We discover to our surprise and consternation that Time is racing past like a flock of wild horses on the open prairie—no chance to seize it by the forelock.

But to come back to the business of planning your fall selling campaign, what's the matter with starting right now? You may think that you are too busy setting up binders, helping your customers put their old machines in order and generally taking care of the seasonal requirements of your customers. But are you too busy? Isn't future business almost as important as present business?—especially if it concerns the near future? In another part of this magazine there is an article by an expert on crop prospects in Canada, indicating that the possibilities of a good crop are favorable in spite of a late spring. And good crop prospects and good implement sales prospects are synonymous. So this is a good time to grab Time by the forelock, straddle her, and start riding toward the bright fall prospects.

THE first step, of course, in planning a fall campaign, is to learn the requirements of your trade. And what better opportunity could a dealer wish for this, than while he is selling haying and harvesting machines and binder twine? When a customer comes in for his machine—or it may be twine or repairs—why isn't it a good plan to FEEL HIM OUT in regard to his fall needs? For instance, after you have sold Jim Jones whatever he happens to want when he comes in sometime during this month of August, why not start a conversation something like this:

"Going to do much fall plowing this year, Jim? What seems to be the drawback? Haven't got enough horses and can't get the labor to plow even your usual acreage, eh? Well, now, that's too bad. I understand Frank Williams is in the same fix or rather, he WAS. No, he didn't have to buy any more horses and he isn't figuring on getting another hired man. Fact of the matter is, he intends to sell four of his horses and is going to try to get along without the extra man he has had working for him during the summer. How does he figure on doing it? Why, it's simple enough when you stop to consider. You see he's placed an order for one of these 10-20 tractors and a three-furrow power-lift tractor plow—a one-man outfit. With this outfit he'll be able to plow as much

in a day as he could with two riding gang plows, ten horses, and two men. Simple when you think of it, isn't it? Well, come in again when you happen to be in town, Jim—always glad to see you whether you buy anything or not. How's the family? Everybody well? That's good. Well, so-long."

Jim Jones goes home with the germ of an idea adroitly planted in his mind—a one-man tractor plow outfit. Perhaps he thinks about it every now and then during the harvest—how much more land he could plow and how much less help he would require if he had a tractor. The dealer has diplomatically laid a stone in the foundation of one branch of his fall selling campaign.

Or instead of a tractor plowing outfit, it may have been a small thresher that the dealer talked about, in which case he may have carried on a conversation something like this:

"Who is going to do your threshing for you this year, Jones? Old Perkins, you say? I thought his outfit was just about on its last legs. Some of his customers last year seemed to think that he ran quite a bit of good grain into the straw stack—the old separator isn't working quite as good as it used to. And then again, when a disinterested crew is running the outfit you can't expect 'em to look out for your interests—not during these days. Will you be able to get Perkins without a long wait? I understand that he's usually dated up pretty well in spite of the unsatisfactory service he gives, as he hasn't got much competition—and old Perk isn't what you could call noted for speed. That's the trouble with most custom threshing outfits—it's hard to depend on 'em. You plan to have the outfit at your place on a certain day and are all ready—and then it doesn't show up. Maybe it's held up by a breakdown or a longer run at some neighbor's than the thresherman expected. Or it might be mired in a mud-hole down the road a ways—or any one of a number of things. Meanwhile you and your grain are waiting for the delayed outfit. If you happen to be a farmer living in a section of the country where they do stook threshing, the chances are that quite a bit of grain will be lost through shelling if the weather is dry and hot. Or if you're visited by a wet, rainy spell while waiting for an outfit like Perkins'es, the chances are that some of the grain is going to sprout.

"Now, it seems to me, Jones, that if I was a farmer and had a tractor, I'd get away from all the uncer-

tainty and expense of having my crop threshed by a custom thresherman. I'd buy myself one of these little individual threshers—a 20x32 or 22x38—that you can handle with a 10-20 tractor. No, you don't need much of a crew; you and your boy with maybe the help of one or two neighbors would keep it going to full capacity. Nice thing about one of these outfits is that you can thresh your crop whenever you're ready—no expensive delays—and you save the biggest part of the money that you'd otherwise have to pay out in threshing fees. Seems kind of foolish, doesn't it, to share your grain profits with someone who had no part in the actual production of your crop? Another thing about one of these little outfits is that you can thresh for a few of your neighbors—and you don't have to maintain a big crew. You keep your tractor busy too, and in so doing are getting the most out of your investment. A mighty sensible arrangement any way you care to look at it, say I. Here's an illustrated catalogue that tells all about one of these threshers, Jim. Put it in your pocket and read it while you're driving home. Can't tell—maybe some day you or some of your neighbors might decide to get a little outfit like that."

And Jim Jones goes home with a thresher taking root in his mind!

SOME other farmer may be in need of an ensilage cutter, corn husker and shredder, or sheller. Another customer may have use for a power hay baler. Or it may be a manure spreader, wagon, tillage tools or grain drill where winter grain crops are planted. In each case a little diplomatic beating about the bush should serve to bring a "rise" from the prospect, indicating the kind of a machine in which he is interested and the extent of his interest.

Selling or experting in the country—making adjustments and repairs on machines in the field—present a still better opportunity to learn the farmers' fall equipment needs. The dealer or his salesman or experts—whoever happens to visit the farmer at his home—by discreet inquiry and careful observation should be able to learn just what new fall equipment the farmer needs.

It is possible, however, to reach only a limited number of farmers through personal interviews so the dealer who is after a maximum fall volume enlists also the aid of his local newspaper if he has one, and the mails. Both direct-by-mail and local newspaper advertising should be begun about six weeks before the actual selling season. This preliminary missionary work when conducted systematically and on the "follow-up" basis, should serve to bring forth a number of good prospects. Many dealers naturally will raise the objection that they have no time for advertising, and anyway, they haven't the advertising training necessary to make a preliminary campaign resultful. This difficulty, however, is quickly disposed of as the leading implement manufacturers are always glad to co-operate with their dealers in planning campaigns and preparing advertising matter both for newspaper display and mailing.

With a good list of prospects in his possession, developed through personal interviews and advertising, the dealer has an excellent foundation for his fall selling campaign.

But in order to build an effective sales structure on this foundation it is necessary that the dealer keep in touch with the prospects—keep them reminded of the machines in which they have indicated interest. A letter, post-card, mailing folder, catalog or similar message a week or ten days apart will help to keep the prospect's interest alive until the dealer has the opportunity to interview him personally.

And, of course, it is always essential that the dealer have  
(Continued on page 38.)



Some farmer may be in need of an ensilage cutter, corn husker and shredder, or sheller.



## International Threshers Provide Your Trade With Full Sacks and Clean Stacks

Thorough separation and clean threshing—these are the things that every thresherman requires of a thresher.

INTERNATIONAL THRESHERS are famous for their thorough separation and clean threshing. Instead of the usual easy-swaying, back-and-forth or up-and-down motion of straw racks, the International combines both in a vigorous revolving motion that results in continuous tossing and turning of the straw so that every particle of grain is shaken out. This means thorough separation. The adjustable sieves and shoe clean the grain thoroughly and deliver all of it to the grain spout instead of some of it to the wind stacker.

The thresher that assures full sacks and clean stacks is the thresher that sells. INTERNATIONAL threshers—22 x 38 and 28 x 46 sizes—have the confidence of the farm public. Our advertising is directing the trade to you for this popular machine. Thresher time is at hand. Communicate with the branch house and make the most of the opportunity.

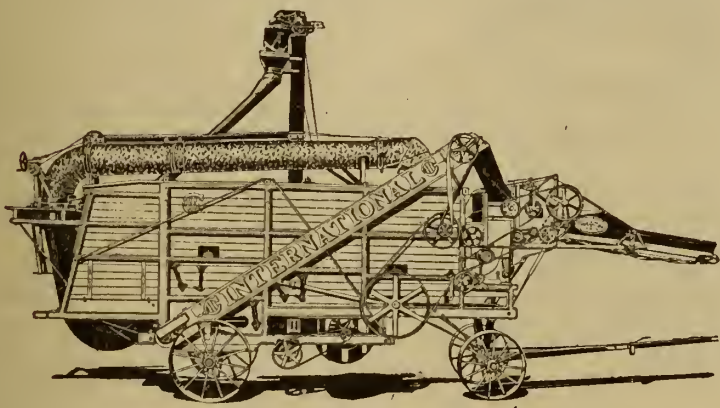
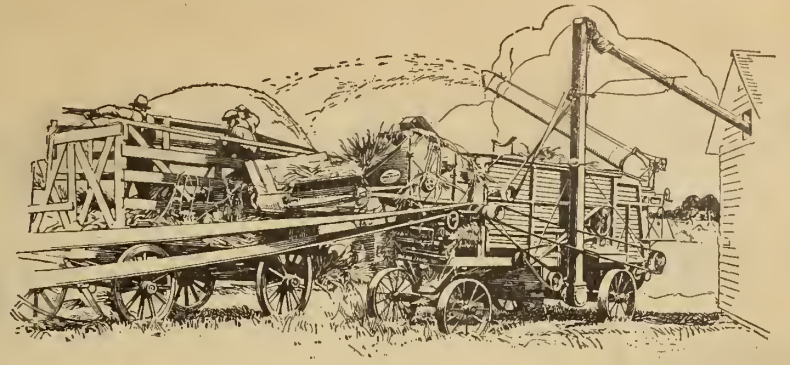

### INTERNATIONAL HARVESTER COMPANY

OF CANADA LTD.

HAMILTON CANADA

WESTERN BRANCHES—BRANDON, WINNIPEG, MAN., CALGARY, EDMONTON, LETHBRIDGE, ALTA., ESTEVAN, N. BATTLEFORD, REGINA, SASKATOON, YORKTON, SASK.

EASTERN BRANCHES—HAMILTON, LONDON, OTTAWA, ONT., MONTREAL, QUEBEC, QUE., ST. JOHN, N. B.

## Twine of Quality for Canadian Farmers

THE matter of supplying the farmer with good binder twine is not merely a twine-selling proposition on the part of the Harvester Company. It is much more than that. It is an obligation.

When the original founders of the Harvester Company gave to the world the first practical twine binders over forty years ago, they automatically assumed the responsibility of insuring satisfactory operation from these machines. They successfully met that obligation with good twine.

To-day this inherited responsibility is greater than ever. Proper operation of thousands of good binders is threatened by the many brands of cheap, inferior twine. It is part of the Harvester Company's obligation to protect the owners of these machines against the hazards of such twine. This protection is rendered by supplying the farmers of Canada with twine of quality that insures sure tying and full length. Such twine bears one of these names:

McCormick Deering International

INTERNATIONAL HARVESTER COMPANY

OF CANADA LTD.

HAMILTON CANADA

WESTERN BRANCHES—BRANDON, WINNIPEG, MAN., CALGARY, EDMONTON, LETHBRIDGE, ALTA., ESTEVAN, N. BATTLEFORD, REGINA, SASKATOON, YORKTON, SASK.

EASTERN BRANCHES—HAMILTON, LONDON, OTTAWA, ONT., MONTREAL, QUEBEC, QUE., ST. JOHN, N. B.

Guaranteed for  
Weight, Strength and Length

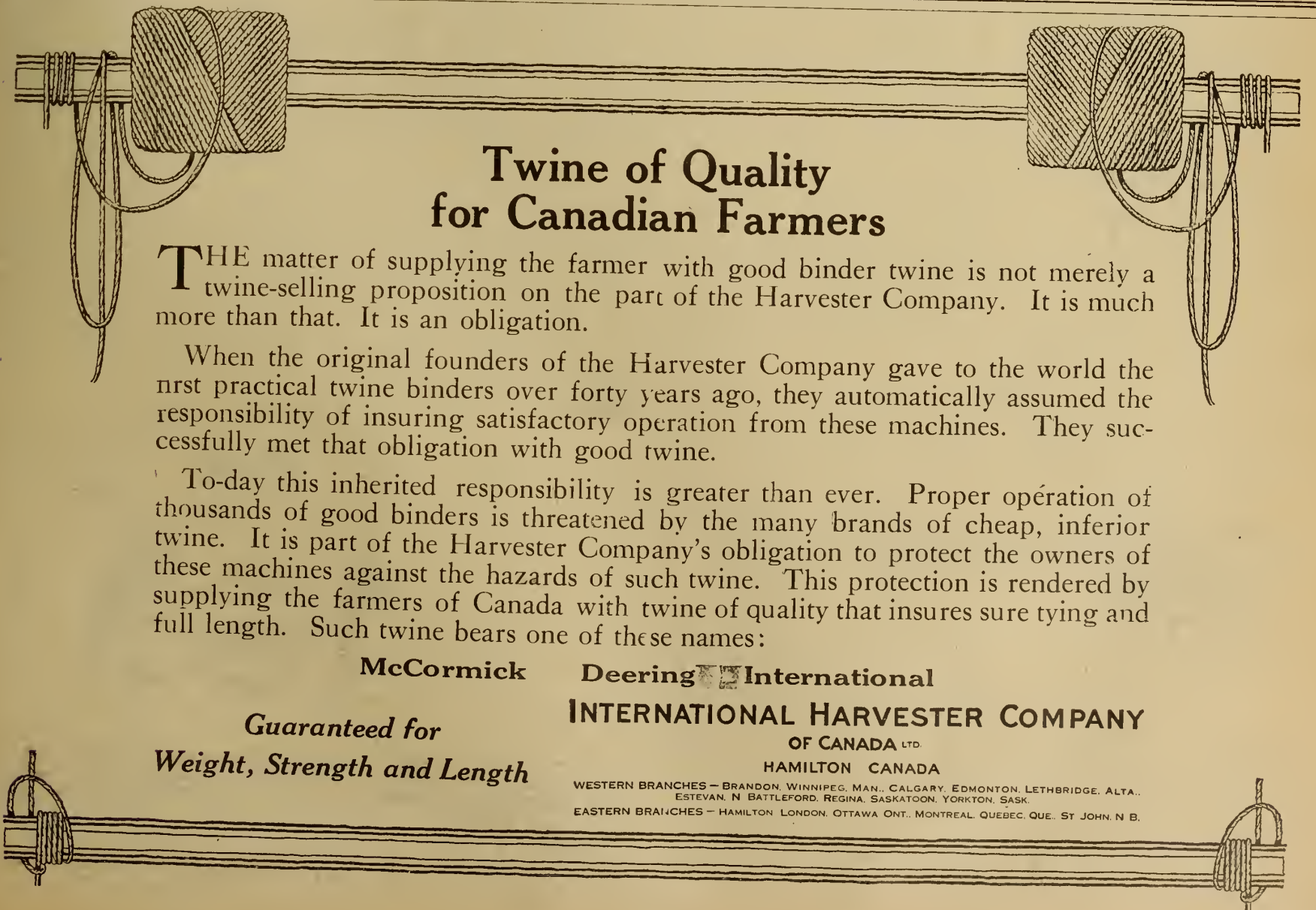



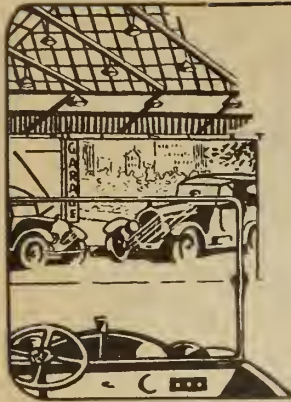

# SHOP NOTES FOR THE GARAGE MAN



## PUTTING ON DEMOUNTABLE TRUCK TIRE

THE following hints on putting on a demountable truck tire should be of considerable interest and value to repairmen, generally, coming as they do from the repair department of the Goodrich Tire and Rubber Co.

In the application of both single and

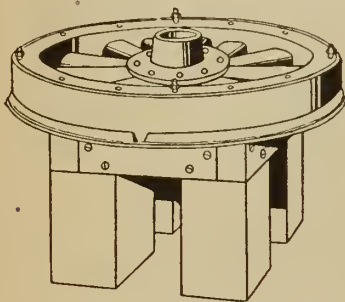

Fig. 1

dual tires there are two flange rings, two wedge rings and a series of bolts which go through the felloe. The only addition for dual tires is a centre band.

In Illustration No. 1 the inside flange and wedge ring have been applied and held in place by four bolts.

No. 2.—Next take the tire, seeing that the greater overhang on the tire

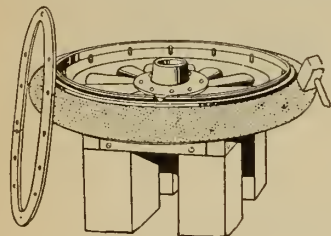

Fig. 2

base is upward, and force it firmly against the wedge ring. Tap it sharply all around on the rubber tread with a hammer.

No. 3.—Slip on the outside wedge ring, making certain that the segment cut falls directly above or opposite the segment cut on the inside wedge ring. Remove nuts on the four bolts,

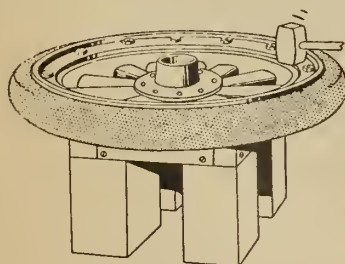

Fig. 3

but make sure the inside flange ring is supported from beneath. Apply outside flange ring, insert all bolts, apply all nuts and tighten down to a point where a wrench is necessary. In tightening nuts start diametrically opposite segment cut in outside wedge ring.

When all nuts are tightened, tap outside flange ring sharply and then

again proceed to tighten the nuts in the same way as before. Repeat until all play is taken up.

The application of dual tires involves the identical same steps except that after the first tire is in place the centre ring is applied between the two tires with the segment cut on the same opposite the cuts in the wedge rings. There is nothing difficult about any phase of the work.

## REMOVING CARBON

SOME suggestion for the removal of carbon by other means than scraping, are given in the "Automatic Dealer and Repairer," by Howard Greene. He says:

"Turn the engine until two pistons are at the top of the stroke and then fill the combustion chamber of the cylinder with both valves closed full of alcohol and screw the spark plug back into place. Let it soak for at least six hours. Each cylinder will have to be treated separately, of course. The alcohol must come into direct contact with the carbon. This treatment will spoil the oil, for the alcohol will run down and mix with it, so, after running the engine a little, throw away the oil and replenish the supply. Running the engine a little with the old oil and alcohol will have the effect of pretty well washing it out and will do no harm if it is not carried too far.

"A method that is often adopted for quickly getting rid of carbon is to do it with water fed in through the carburetor. Run the engine at a good speed, but not racing, and while running feed water to the carburetor air intake. If too much is fed the engine will slow down and stop, so the quantity must be regulated to a flow that will not cause too much slowing down. A good deal of carbon will be loosened and blown out, and in many cases the combustion chambers and piston heads will be very thoroughly cleaned up.

"By judicious use of these methods the accumulation of carbon can be so kept down that it will cause no trouble, and it is far better, from every point of view, to take a little trouble at frequent intervals than to have overheating, pre-ignition and so on, followed by a regular job of carbon scraping at an inconvenient time—that is, if there ever is a time when carbon scraping is not inconvenient."

## COMBINATION VISE

This is a combination vise that performs many varied duties. It combines the drill press vise, V blocks and angle plate. The makers say, it enables the operator to hold a round piece of stock in a vertical position for drilling holes in the end of the bar. It provides for holding the rod or bar at an angle, while drilling a hole at other than right angles, an operation that generally results in a broken drill unless the stock is held securely. The vise is made by the Germanow-Simons Machine Works, Rochester, N. Y. Two sizes are provided, one that has a jaw opening of 5 inches, and the other a jaw opening of 7 inches.

## HOLE IN RIM HELPS REMOVE TIRES

IN warm weather an automobile tire is apt to stick to the rim of the wheel, which makes it difficult to remove. This trouble can be avoided by making holes in the rim large

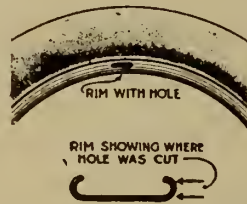

enough to admit the tire tool, which is thrust through the hole and dislodges the tire. Each aperture is made by drilling small holes side by side and joining them together with a file. If the apertures are made, about a foot apart, the rim will not be weakened enough to cause danger.

## FOR SUPPLING UP STIFF ENGINES

THE repair man is frequently faced with the necessity of suppling up a stiff engine, and in a shop where there are no facilities for coping with such a thing it is a harassing job.

The usual procedure in such cases is to push the car about by hand, or where practicable to take it out and run it around until the stiffness is removed. This method absorbs more time and man power than the operation warrants. Then as the modern tendency is to have the repair room on an upper storey the advantages of the system are apparent.

There are several machines on the market for coping with a stiff engine, but a satisfactory device, and one where very little expense is involved, can be made by any repairman.

This apparatus was devised and is now being used by Pink's garage, Pembroke, Ontario.

It consists of two short shafts—an idler and driver resting on bearings underneath the floor—on each of which are two grooved pulleys fixed at the proper distance where the rear wheels of the car rest, as shown in the accompanying illustration. When the car is resting on the pulleys the rear wheels are about on a level with the floor. Just what type of bearings will be used depends on the local conditions, such as the construction of the floor, position of joists or supports, etc., etc. On one end of the driver shaft there are two pulleys—one fast and one loose—connected to the main shafting by means of a belt.

A car placed in this simple device can be run for an indefinite period, or until such time as the stiffness has disappeared, without attention.

## AUTOMOBILE BODY POLISH

A GOOD automobile body polish that has stood the practical test successfully and calculated to restore even an old car to a degree of brightness is made by mixing the following ingredients:

Turpentine, 1 gallon; paraffine oil, 1 pint; oil of citronella, 3½ ounces; oil of cedar, 1½ ounces. Another scheme is to use a mixture of boiled linseed oil and turpentine, applying it sparingly and rubbing absolutely dry.

## HOTELS AND GARAGES ACCEPT OUR MONEY

SCORES of American hotels and garages have replied to a letter sent them by the Secretary of the Ontario Motor League in reference to accepting Canadian money at par from Ontario motorists who present their membership card. In nearly every instance hotel and garage men state they will honor Canadian currency without discount providing the motorist proves he is a member of the Ontario Motor League.

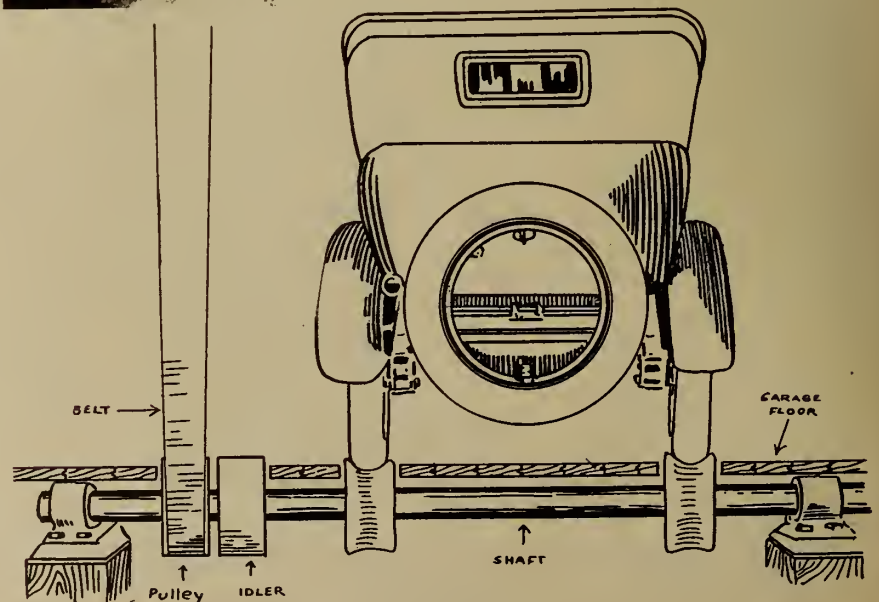

Suppling Up Device.



# Frost & Wood Binder

*The Farmer's Favorite---Easiest to Sell*

As a live Implement Dealer you want to handle not only the Binder that does the best work but the one that has earned the greatest popularity—that means the Frost & Wood.

The Binder is the Implement that "brings home the bacon" for the farmer. He is more cautious over the choice of this machine than any other he buys, and rightly so. The many years successful experience of the Frost & Wood Binder is well known to thousands of farmers all over Canada. It is the intelligent farmer's choice because it is known as—



## The Binder that gets all the Crop with the greatest efficiency in any field

The value of a Binder that will handle satisfactorily any kind of crop can hardly be over-estimated. The Frost & Wood through superior design, flexibility and strength cuts, elevates, and ties a heavy, down or tangled crop with a thoroughness that is a delight to

its owner. It is built not only for ideal conditions but also for abnormal—the thin and light fields or the crop that has suffered the battering of a storm. All this has been demonstrated over so many years of experience that your time and energy in selling it is reduced to a minimum.

**Light draft through high grade materials and best roller bearings**

Built for long, hard service and heavy jolts in rough fields. We have used the highest grades of steel, and experience has shown us where to put in weight and where to leave it off. Best roller bearings, dirt and grit proof yet easily oiled, at all friction points. Very flexible and easily handled reel adjustment brings the grain to the cutter bar. Special elevating mechanism adjustable to any weight of crop—no choking or wastage. Whole machine is splendidly balanced—no straining or wrenching—works smoothly in every part.

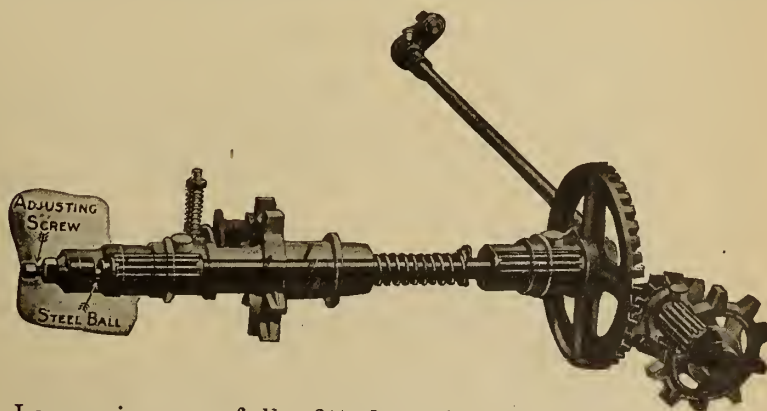

Large size, carefully fitted, easily oiled and adjustable bearings ensure light draft and long life.

Let us send you our complete-line Dealer Proposition. See the splendid business possibilities it opens up for you.

**The Frost & Wood Co.**  
LIMITED

Montreal SMITH'S FALLS St. John

Sold in Western Ontario  
and Western Canada  
by

**Cockshutt Plow Co.**  
LIMITED

BRANTFORD, ONTARIO



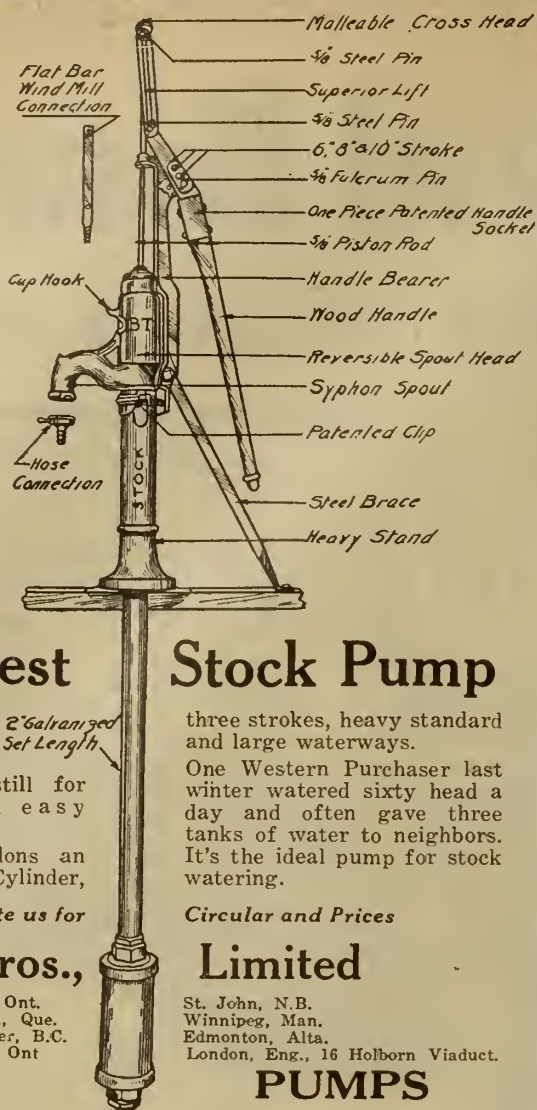

## The Best Stock Pump

The BT No. 5 Ready-To-Ship Pump has the old wood pump beaten to a standstill for capacity, wear and easy pumping.

It raises 1,800 gallons an hour; has 5x12 Iron Cylinder,

Write us for

**Beatty Bros.,**

Fergus, Ont.  
Montreal, Que.  
Vancouver, B.C.  
London, Ont.

**WELL**

three strokes, heavy standard and large waterways.

One Western Purchaser last winter watered sixty head a day and often gave three tanks of water to neighbors. It's the ideal pump for stock watering.

Circular and Prices

**Limited**

St. John, N.B.  
Winnipeg, Man.  
Edmonton, Alta.  
London, Eng., 16 Holborn Viaduct.

**PUMPS**

## In All Parts Of the Dominion

Implement dealers and agents can point to customers who are using the

### **O-K CANADIAN POTATO DIGGER**

and getting excellent results.

Many letters have come to us from potato growers who have bought O-K CANADIAN DIGGERS after seeing them operate on neighboring farms.

The best kind of selling argument is the one that is built on achievement and satisfactory service. The achievements of O-K CANADIAN DIGGERS are satisfying owners all over Canada.

#### DEALERS

Write for our selling proposition and literature to-day. It will interest you.

### Canadian Potato Machinery Co.

59 Stone Road - Galt, Ontario Limited

Makers of O-K Canadian Planters, Diggers, and Sprayers, two-row and four-row, and the O-K-Spra and the O-K Aylmer Barrell Sprayer.

## NEWS — OF THE TRADE FOR THE TRADE

### ONTARIO

**GRIMSBY.**—A plant was opened here recently for the manufacture of the "Economic" Electric Iron.

**KINGSTON.**—Fire caused considerable damage recently to Blue Garages Limited, Brock Street.

**ST. CATHARINES.**—W. J. Elliott has been elected a vice-president of the Whitman & Barnes Mfg. Co., Akron, Ohio, manufacturers of small tools.

**TORONTO.**—The Petrol Oil and Gas Company, Limited, has been incorporated with a capitalization of \$1,000,000.

**TORONTO.**—Gabriel Mfg. Co., Cleveland, Ohio, manufacturers of automotive equipment, will open a Canadian branch in this city.

**WINDSOR.**—The Canadian Fairbanks-Morse Co., Ltd., are erecting a building on Pitt Street, 50x90 feet to be used for sales offices and warehouse.

**TORONTO.**—Incorporation is announced of the East Washing Machine Company, Limited. Capital \$400,000, divided into 4,000 shares of \$100 each.

**BROCKVILLE.**—The Canadian Briscoe Motor Company, recently, removed its head office from Toronto to Brockville.

**TORONTO.**—Owing to ill-health, R. Howell, manager of the Toronto headquarters of R. A. Lister & Co., has had to resign his position.

**LEAMINGTON.**—H. N. Fox Co., Ltd., has been incorporated to deal in automobile accessories, hardware and electrical supplies.

**TORONTO.**—Announcement is made of the incorporation of the Kemp Metal Auto Wheel Company, Limited, with a capital of \$100,000 divided into 1,000 shares of \$100 each.

**TORONTO.**—Toronto, it is said, now stands second among the cities of America for the number of automobiles in use in proportion to population. Los Angeles takes first place.

**TORONTO.**—Traction Rims, Ltd., has been incorporated to manufacture automobile accessories. Capital \$50,000, divided into 500 shares of \$100 each.

**KITCHENER.**—Motor Accessories and Supplies, Ltd., has been incorporated with a capital stock of \$40,000, to manufacture automobile supplies, electric machines, fixtures, etc.

**TORONTO.**—The Compton Car Co., Ltd., has enlarged its present premises by adding an adjacent building which was constructed for motor sales and merchandising.

**TORONTO.**—Announcement is made of the incorporation of Canadian Technical Products Co., Ltd., with a capitalization of \$100,000. The new firm will manufacture, import and export motors and dynamos.

**TORONTO.**—The Massey-Harris Co. are offering 54 prizes, aggregating \$295, for competition among the employees for suggestions as to the improvement of the operation of the industry.

**CHATHAM.**—Fulton Motors Corporation are arranging to manufacture the 1½-ton truck in Canada. The Denby Motor Truck Co., Chatham, will

handle the manufacture and distribution of this truck.

**BRANTFORD.**—The local manufacturers report good business and practically every factory is working on full time. The Waterous Engine Works has put on a night shift to catch up with orders.

**TORONTO.**—The Ontario Motor League's annual picnic for the orphan children of Toronto, took place recently when 200 hundred members' cars conveyed nearly 1,200 children to Scarborough Beach.

**BRANTFORD.**—Large numbers of the farmers of Brant County, recently, motored to the Ontario Agricultural College for the Annual Inspection. The Brant County Board of Agriculture was in charge of the excursion.

**WOODSTOCK.**—J. F. McDonald, a farmer of Oxford County, with a three-furrow plow drawn by a tractor, plowed a twenty-acre field in thirty hours. With the tractor and an eight-foot plow the same farmer cultivated seventy-five acres in thirty-five hours.

**PORT ARTHUR.**—The Port Arthur Shipbuilding Company, it is expected, will go in extensively for the manufacture of tractors, road rollers, etc. They are planning to double the capacity of the plant and double the number of employees.

**TORONTO.**—Plans are completed for the erection of an Automobile Club, garage and service station, at the south-west corner of Richmond and Shepard Streets. The building will be eight storeys high and accommodate about 1,000 cars.

**PETERBORO.**—The Peterboro Automobile Association is agitating for better motor car service by ferry from Cobourg to Charlotte, which is the port of Rochester. The Association complains that, at present, motors have to be loaded on freight cars at exorbitant prices.

**TORONTO.**—The Republic Motors, Ltd., will shortly open a new two-storey building on St. Alban's Street. The new service station is 100x188 feet, built to accommodate 100 cars on the ground floor. The upper floor will be devoted to motor accessories, repairs, etc.

**ST. CATHARINES.**—The St. Catharines Motor Club has started a campaign with the object of securing as members of the club all car owners in St. Catharines. New officers have been elected for 1920, with A. H. Wallace as president and J. E. Roffer, vice-president.

**TORONTO.**—Leyland Trucks, product of Leyland Motors Limited, England, will soon be manufactured in Canada, at Toronto. W. E. Humphreys is in charge of Leyland Motors, Limited, of Canada, with temporary headquarters in the Manning Arcade, King Street East.

**BELLEVILLE.**—C. I. White, in his report to the Belleville City Council on the first year's work of the Industrial Commission, points out that seven industries have been secured for Belleville in that period: The Elliott Machinery Co., the Judge Jones Milling Co., the H. A. Wood Manufacturing Co., the Natural Tread Shoe Co., the Toronto Hat Manufacturing Co., the A. S. Richardson Co., and the Wood Harvesting Machine Co.





Case 22-40 Kerosene Tractor pulling  
4 bottom Grand Detour Plow.



Case 15-27 Kerosene Tractor pulling  
3 bottom Grand Detour Plow.

## Now is the Time to Sell Tractor Plowing Rigs

**W**ITHIN a week or so, the farmer, with his grain crop out of the way, will be at his greatest need of the year for a Case Kerosene Tractor and the properly related Grand Detour Plow. At the same time, with his grain crop safe, he will be at the peak of his purchasing power for the year. Sell him the rig he needs.

The 10-18 Case Kerosene Tractor will pull a 2-bottom Grand Detour Plow, or three 12-inch plows under favorable conditions. The 15-27 Case Kerosene Tractor will pull a 3-bottom Grand Detour Plow, or four bottoms under favorable conditions. The 22-40 Case Kerosene Tractor will pull a 4-bottom Grand Detour Plow, or will operate a 5-bottom plow under favorable conditions.

And after plowing season is over, the Case Kerosene Tractor may be kept profitably employed throughout the year driving or drawing other farming machinery bearing the trade mark of the Eagle on the Globe.

**J. I. CASE THRESHING MACHINE CO., Inc.**

Dept. O-7, 345-9 Dufferin St., Toronto, Ontario  
Making Superior Farm Machinery Since 1842



Look for the  
EAGLE  
Our Trade Mark

**NOTE:**

We want the public to know that our plows and harrows are NOT the Case plows and harrows made by the J. I. Case Plow Works Co.

To avoid confusion, the J. I. CASE THRESHING MACHINE COMPANY desires to have it known that it is not now and never has been interested in, or in any way connected or affiliated with the J. I. Case Plow Works, or the Wallis Tractor Company, or the J. I. Case Plow Works Co.

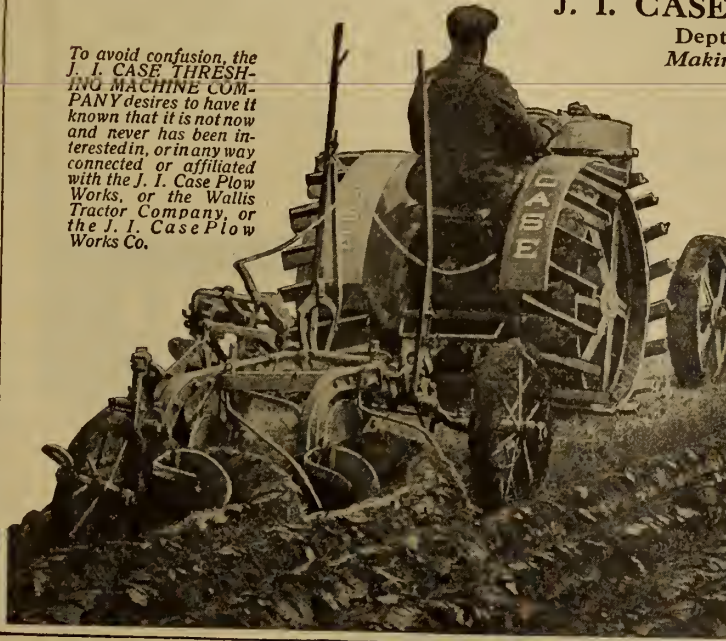

**CASE**  
TRADE MARK REG. U.S. PAT. OFF. AND IN FOREIGN COUNTRIES  
**POWER FARMING MACHINERY**

Case 10-18 Kerosene Tractor pulling  
2 bottom Grand Detour Plow.



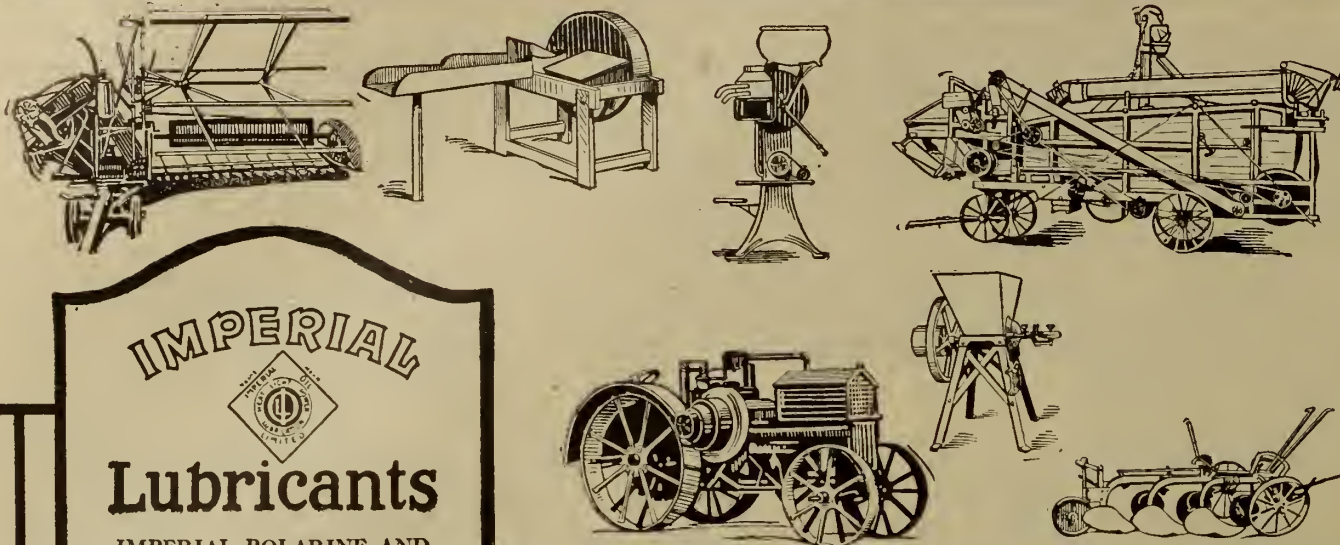

## IMPERIAL Lubricants

### IMPERIAL POLARINE AND IMPERIAL POLARINE HEAVY

For all gasoline-burning engines—  
automobiles, tractors and trucks.

### IMPERIAL POLARINE A

For all motors requiring an un-  
usually heavy oil.

### IMPERIAL POLARINE KEROSENE TRACTOR OIL AND IMPERIAL POLARINE KEROSENE TRACTOR OIL EXTRA HEAVY

For kerosene-burning stationary  
engines and tractors.

### IMPERIAL PRAIRIE HARVESTER OIL

A heavy-bodied oil for open bear-  
ings of threshers, binders and sep-  
arators.

### IMPERIAL ELDORADO CASTOR MACHINE OIL

A thick oil for worn and loose  
bearings.

### IMPERIAL CAPITOL CYLINDER OIL

For steam cylinder lubrication—  
tractors and stationary engines.

### IMPERIAL STANDARD GAS ENGINE OIL

For stationary and portable engines  
using either kerosene or gasoline.

### IMPERIAL THRESHER HARD OIL

For grease cup lubrication of  
bearings. A clean, solidified oil.  
Imperial Farm Lubricants are for  
sale in  $\frac{1}{2}$ , 1 and 4 gallon sealed  
cans, half-barrels and barrels.

## All Need Lubrication

**E**VERY farm machine needs lubrication and only  
the correct lubricating oil or grease will do if  
the full work built into the machine by the maker  
is to be obtained.

The farm lubricating business in your community is  
a big one and a profitable one. Go after it with a  
stock of the full line of Imperial Farm Lubricants.

Stock up with the different packages of each grade  
and canvass your territory.

Strong, effective *selling* advertisements are now run-  
ning in practically every farm paper in Canada—  
papers which reach into your district.

Imperial Farm Lubricants are the only complete  
line of farm lubricants advertised consistently year  
after year.

Farmers know their quality well. Ask the Imperial  
Oil Salesman about our selling helps.

**IMPERIAL OIL LIMITED**  
Power - Heat - Light - Lubrication  
Branches in all Cities



## News of the Trade

### QUEBEC

**MONTREAL.**—The Northern Electric Company is considering some additions to the factory on Shearer St.

**MONTREAL.** — Hutchinson Car Roofing Company, Limited, has been incorporated with a capital stock of \$500,000.

**MONTREAL.** — A. Dwight Smith, formerly sales manager of the Northern Electric Company in the Montreal District, has been transferred to the Montreal Head Office.

**MONTREAL.**—The Northern Electric Company has inaugurated a plan for an employees' pension and benefit fund, the entire cost of which will be borne by the company.

**MONTMAGNY.** — The National Farming Machinery Co., Ltd., which is capitalized at \$4,000,000, is preparing to go into the manufacture of all kinds of farm machinery and stationary engines, on a large scale.

**MONTREAL.**—C. J. Martin, former manager of the Canadian Fairbanks-Morse, Winnipeg office, has been appointed vice-president and general sales manager with headquarters in Montreal.

**MONTREAL.** — Percy Gomery, director of the Vancouver Automobile Club started from Montreal recently on a motor drive to Vancouver, via North Bay, Sault Ste. Marie and Winnipeg. He thus inaugurated the initial attempt to establish a northern trans-continental motor route to be known as "The King's International Highway."

### ALBERTA

**MUNDARE.**—P. Pasterick has opened an implement business here.

**RIMBEY.**—Farrell & Peabody have opened a new implement business and report a good number of sales.

**CALGARY.**—Drilling for oil is actively proceeding in four wells in the Peace River District, according to a report of the Peace River Board of Trade.

**CALGARY.**—N. S. Richards, who has been for the past three years connected with the Northern Electric Company in the Calgary District, has been transferred to Montreal as a sales manager of the Montreal District.

**CALGARY.**—L. B. Cravath, who for sometime represented the Advance-Rumely Co., in Calgary, was recently appointed a special representative of the Home Office Sales Department of the J. I. Case Plow Works Co., Racine, Wisconsin.

### MANITOBA

**BRANDON.**—A commercial flying company has been floated and will be formed here.

**CARTWRIGHT.**—A new implement business has been started here by Messrs. Mooney and Robinson.

**WINNIPEG.**—At a recent meeting of the Provincial Good Roads Board road work was approved amounting to \$161,500.

**MELITA.**—A Cockshutt agency has been opened here by James Duncan who was connected formerly with Cameron & Duncan, of Melita.

**DAUPHIN.**—The Sutherland-Stelck Company, dealers in implements and hardware, are applying for authority to increase their capacity stock from \$40,000 to \$200,000.

**WINNIPEG.**—Automobiles driven over 25 miles an hour will be impounded according to a recent announcement of the Police Magistrate. In addition to being deprived of their cars for a week, speeders will be fined.

**WINNIPEG.**—Winnipeg is rapidly increasing in motorization. According to a recent estimate there are 17,351 cars, or approximately one car to every 15 persons, basing the figures on a population of 262,000.

**WINNIPEG.**—Kenneth N. Forbes, who for the past five years has been manager for the Canadian Fairbanks-Morse Co., at St. John, N.B., has been transferred to the Winnipeg office of that concern in similar capacity.

### SASKATCHEWAN

**ESTEVAN.**—An implement warehouse has been opened by W. J. Jaques.

**FORT QU'APPELLE.**—The Valley Garage, it is reported, has changed hands.

**ESTON.**—Jackson Bros.' is the name of a new implement concern which has started business here.

**WATROUS.**—G. S. Parsons has purchased the implement business conducted by W. A. Leslie.

**ROLAND.**—R. Chanin has purchased the implement business formerly conducted by F. T. Dawson.

**LENEY.**—The implement business conducted by E. P. Horton has been formed into a company under the name of Horton's Limited.

### BRITISH COLUMBIA

**VANCOUVER.** — The Strathcona Garage is the name of a new automobile business in Vancouver.

**VANCOUVER.**—Nash Motor Sales, Ltd., has erected a new building on George Street, 100x150 feet.

**VANCOUVER.** — The Vancouver Brake Lining Service Station is a new concern with headquarters on Grenville Street. They will handle brake lining exclusively.

**VICTORIA.** — British Columbia is experiencing what is termed its greatest tourist season. Victoria is getting its fair share and is energetically devoting its attention to the reception of guests from the Northern States.

### MARITIMES

**ST. JOHN, N.B.**—W. J. Hill has been appointed local manager for the Canadian Fairbanks-Morse Co.

**FREDERICTON, N.B.**—The Provincial Department of Public Works, is placing road signs on all trunk highways and important by-roads.

**ST. JOHN, N.B.**—Daylight saving has been established here during the months of June, July, August and September.

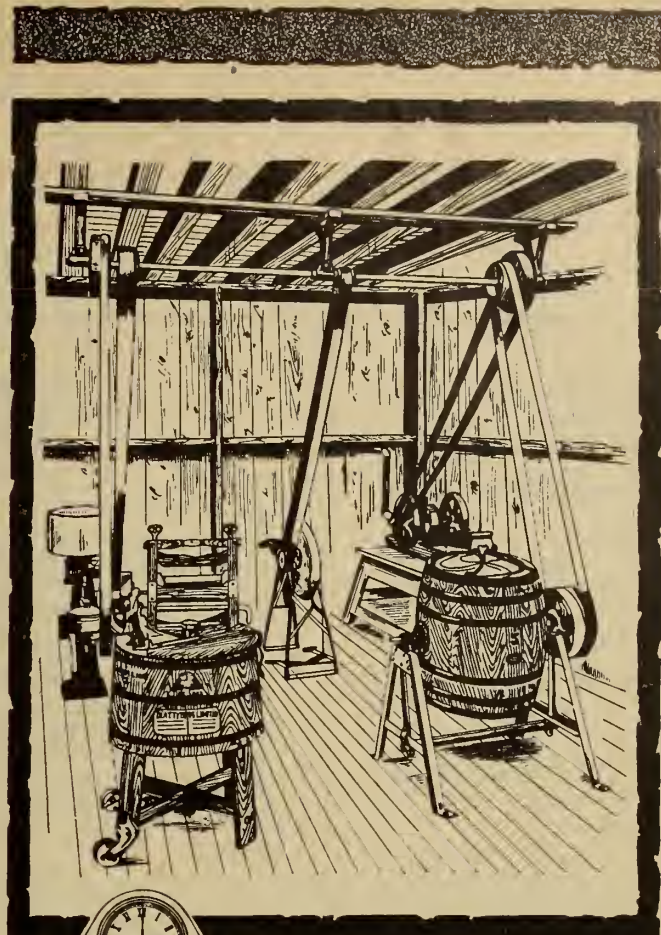

## Time Saver Engine Drive Washer

Get  
Value  
For Your  
Customer

Sell the Time Saver Engine Drive washer and give your customer the best possible value.

Sell as well, a BT Line Shaft and a BT Gasoline Engine. The Engine and Line Shaft will run churn, grindstone, separator, and all the other small machinery. They are a neat, compact power plant for running the domestic appliances. A card will bring full details.

**Beatty Bros.  
Limited**

St. John, N.B.  
Montreal, Que.  
Fergus, Ont.  
London, Ont.  
Winnipeg, Man.  
Edmonton, Alta.  
Vancouver, B.C.  
London, Eng.  
16 Holborn Viaduct

## Feed Grinder Troubles are usually plate troubles

Your own experience will tell you that most kicks on the efficiency of Feed Grinders are caused by faulty grinding plates. And it's a pretty stiff proposition convincing an irate farmer that he has bought a good feed grinder—or even that he has dealt with a reliable dealer—when he isn't getting grain ground the way he wants it because the grinding plates on his machine are not living up to advance notices.

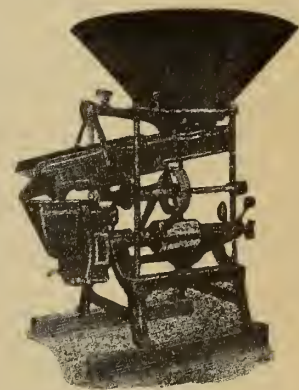

You take no chance of a customer coming back at you if you sell him a Vessot Feed Grinder. Vessot Grinding Plates will grind better and wear longer than any plates he ever heard of.



Write the nearest branch of the International Harvester Company for particulars of the Vessot Agency proposition

**S. VESSOT & COMPANY, JOLIETTE, QUEBEC**

Sold exclusively in Canada by

International Harvester Co. of Canada, Limited.

Branches: Calgary, Edmonton, Lethbridge, North Battleford, Regina, Saskatoon, Estevan, Yorkton, Brandon, Winnipeg, London, Hamilton, Ottawa, Montreal, Quebec, St. John.



# Two Renfrew Lines That Will

## What a Few Renfrew Separator Users Say About Their Machines

"I don't think it could be improved on. It is perfect," writes Mrs. E. Taggart, 409 West Quartz street, Butte, Montana. "It is better in every way than any other separator."

Mr. Andrew Taylor, Widdifield, Ont., writes that he would not be without a Renfrew on any consideration.

"A fair sized child can turn the Renfrew," says Mr. William J. Eddie, R. R. No. 4, Glencoe, Ont., who has a herd of twelve cows.

"We have been highly congratulated on the cream separated by the Renfrew." Statement of Maurice Black, Spencerville, Ont., R. R. No. 2; herd of 35 cows.

Mrs. Mary Jane Killoran, R. R. No. 7, St. Mary's, Ont., writes: "I like the Renfrew better because it is easier turned, easier oiled and cleaned and makes better, cleaner cream and butter than any other separator."

"The Renfrew is superior to any I ever saw. I would not ask for any improvement. It is very easily turned, and a very easy one to take care of," writes Mr. John E. Bolser, Port George, Anna County, N. S. "It is the machine I would recommend," he adds.

In four years Mr. George B. Hirtle, New Germany, N. S., has paid out nothing for repairs on his Renfrew. "My children, 10 and 12 years, work it." He likes it because it is such a "very close skimmer."

Mr. Hance H. Fidd, R. R. No. 1, Pugwas, N. S., writes that he considers the Renfrew "better in every way" than any other separator made.

"I think it is the best I have ever seen," writes Mr. Wm. Haws, Callander, Ont. "It skims the milk better, and is easier running."

Mr. James H. Carr St. Williams, Ont., reports that he is more than pleased with his Renfrew.

Mr. C. A. Cragg, R. R. No. 2, Thamesville, Ont., who has had his machine for five years, writes us that it is superior to any other separator made, because "it runs easy, skims close, is easily oiled, and is easy to keep in order."

"I have the first rubber ring in my separator now. And I have used the machine twice a day ever since I bought it," reports Mr. John Barron, R. R. No. 1, Princeton, Ontario, who has owned a Renfrew for four years. He has paid out nothing for repairs in that time.

"We have had this one (Renfrew) five years and never had any trouble with it whatever. We like it very much." That is what Mr. John Amies, R. R. No. 3, Mount Brydges, Ont., tells us. "What friends we know have your machine; will always recommend it at any time."

Mr. Thomas D. Armstrong, Kinburn, Ont., has had his separator seven years, and in that time he has paid out nothing for repairs. He likes the close skimming ability of the Renfrew.

## The Cream Separator

Few articles on the market are as rich in selling features as the Renfrew Cream Separator. A shrewd judge of values, and a careful buyer, the farmer invariably recognizes its value and many merits.

A Renfrew Separator salesman is never stumped for sound selling arguments, because Renfrew merits are really innumerable, and they are points that the farmer will sense as of value to him in his business.

Selling Renfrew Cream Separators is no longer a case for aggressive salesmanship. We have spent big sums of money advertising the separator in the best farm papers.

Almost every Canadian farmer now knows the Renfrew because of these advertisements, and all that a great many of them need is simply a visit from you. They will ask shrewd, pointed questions; they will display a pretty intimate knowledge of separators, but the Renfrew selling features will prove convincing and entirely satisfactory.

Briefly, these are a few of the most important selling features:

- (a) It gets 99.99% of the butter fat—proved again and again by Government Dairy School Tests. No waste. Money saved.
- (b) It is actually so simple of construction and operation a child can run it perfectly. Labor-saver.
- (c) It is the easiest to keep clean. Time and trouble-saver.
- (d) It is the only separator with a successful interchangeable capacity. No loss when herd enlarged.
- (e) It is self-oiling, and requires refilling with oil only four times a year.
- (f) All gearing enclosed. Clothing cannot get caught or children's fingers hurt.
- (g) Produces thicker cream and firmer, sweeter butter, for which farmer gets better prices.
- (h) Has low supply tank and high crank—features which women universally approve.

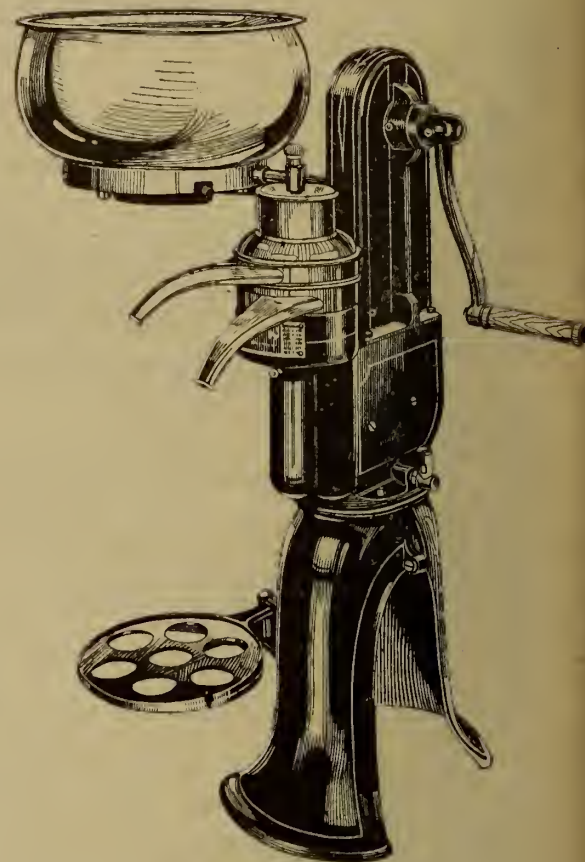

These are just a few of its many excellent points. There are many others that will interest the farmer. It is a fine opportunity for you, for the Canadian farmer is already more than half-sold on the Renfrew and the commissions that you can make are really handsome. Write us to-day for full particulars, as there is still some good territory open.

# Renfrew

## Cream Separator

### The Renfrew Machine

Head Office and

Branches: Montreal, Que.; Sussex, N.B., Milwaukee, Wis., U.S.A.



# I Bring You Splendid Profits

## The Truck Scale

The Renfrew Truck Scale has proved just as spectacular a seller as its running partner—the separator. For one thing the demand for a sturdy, handy scale for the farm has been urgent, and our scale was exactly what the farmer was looking for.

The farmers who have bought them tell us that they could not get on without them now, that their losses in deals must have been very considerable before, and that they are saving money now through having them. (A glance at what some Renfrew Scale users have written us will show you what we mean).

And yet there are thousands upon thousands of Canadian farmers who have no scales or else have cumbersome platform scales that are only proving a nuisance. These farmers are splendid prospects for you. As with the Separator, we have advertised our Truck Scale very extensively through farm papers, and Canadian farming men and women are familiar with it through that medium. A visit from a Renfrew Scale salesman and perhaps a demonstration will satisfy the great bulk

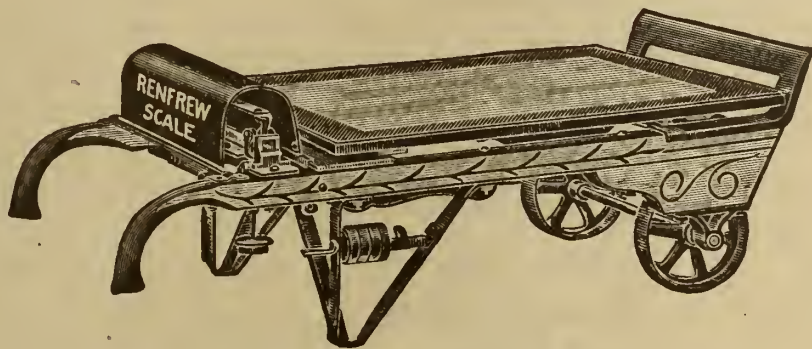

of them that they cannot be without one any longer.

The Renfrew Truck Scale abounds in selling features, some of which are:

- (a) It will weigh anything from a pound to a ton in weight.
- (b) It is absolutely accurate. Every scale tested by a Government inspector, his certificate being attached to each scale.
- (c) The farmer can take this light, handy truck to the articles he wants to weigh.
- (d) Has wide wheels which will not let it sink into soft ground.
- (e) Is built sturdily to withstand the hardest wear.
- (f) Can be wheeled around like a truck (see drawing).
- (g) When not in use can be stood in a corner out of the way.
- (h) Safeguards farmer in getting full value when farmer is buying or selling.
- (i) It is self-adjusting and will weigh correctly on uneven ground.

You will have no difficulty in convincing the farmer that he needs one. As we said, thousands upon thousands of them need only your visit to help make them decide to buy.

The commissions are unusually large. Territories are going fast. We advise you to write us at once for full particulars.

## Some Compliments From Owners of Renfrew Scales

Mr. D. B. Haskett, R. R. No. 5, London, Ont., writes that "on more occasions than I can keep track of the Renfrew Truck Scale has saved me money. It will weigh anything from a cow to a chicken."

In a deal in hay, Mr. Rufus Botting, Godfrey, Ont., reports that his Renfrew Truck Scale saved \$25.00, in a grain deal \$10.00, and in another in pigs, it saved \$15.00. Altogether in the three deals he mentions, it saved him \$50.00. In the 5½ years he has used it, his scale has proved entirely satisfactory.

Mr. Wilfrid Quenneville, Desaulniers, District of Nipissing, Ont., reports that his Renfrew Truck Scale saves him money every time he is selling anything. The self-adjusting feature has been of value to him when weighing hay.

"The first fall I had them they saved me the price of the scales in wheat alone," writes Mr. Fred Ladroute, Westmeath, Ont. He thinks every farmer should have a Renfrew Scale, because "then the owner knows what he gets when he buys, and he doesn't lose anything when he sells." They give standard weight, and they are easy to move around.

On one shipment of hogs, John H. Johnson, R. R. No. 2, Croton, Ont., saved \$10.00 and shortly afterwards, he saved \$15.00 on a cattle deal. He also believes every farmer should own a Renfrew Truck Scale.

"They are the handiest scale on the market," writes Mr. Alex. Backus, R. R. No. 1, Simcoe, Ont., who saved 3 bushels of wheat in one load, and 80 pounds on one lot of hogs, thanks to his Renfrew Scale.

Mr. Kirby Newstead, R. R. No. 3, Atwood, Ont., weighed 2,500 pounds on his Renfrew Scale. He finds it absolutely satisfactory and says it has saved money for him many times.

"I think my scales more than paid for themselves in a very few days weighing out hay," writes Mr. Wm. J. Hough, R. R. No. 2, Prescott, Ont.

Mr. Hugh Fitzgerald, R. R. No. 2, Jasper, Ont., has owned his Renfrew for ten years and in that time it has always given perfect satisfaction. "It has saved money every time it was used," reports Mr. Fitzgerald. "It saves time, takes up no room, and will last a life time."

# Renfrew

## and Truck Scale

Company, Limited

Renfrew, Ont.

Other Lines: Happy Farmer Tractor, Renfrew Oil Engine



# A Complete Line of Farm Implements for the Massey-Harris Agent

Grain Binders  
Reapers  
Corn Harvesters  
Mowers  
Rakes  
Side Del'y Rakes  
Tedders  
Hay Loaders  
Cultivators  
Seeders  
Hoe Drills  
Shoe Drills  
Disc Drills  
Fertilizer Drills  
Fertilizer Sowers  
Disc Harrows

Drag Harrows  
Harrow Carts  
Feed Cutters  
Pulpers  
Grinders  
Ensilage Cutters  
Manure Spreaders  
Cream Separators  
Plows, Scufflers  
Land Rollers  
Packers  
Wagons  
Sleighs  
Gasoline Engines  
Saw Outfits  
Tractors, Etc. Etc.

*Mail your application for representation in vacant territory to the Manager of the Branch nearest you.*

## MASSEY-HARRIS CO., Limited

Head Office: - Toronto, Ont.

*Branches at*

Montreal      Moncton      Winnipeg      Regina      Saskatoon      Swift Current  
Yorkton      Calgary      Edmonton

### BEATTY BROS. INCREASE STOCK

BEATTY BROS., Fergus, Ont., have increased their capital stock from \$750,000 to \$2,000,000 to provide for the erection of several factory additions and for the purchase of equipment to the value of \$150,000 this year.

### SEVEN IMPLEMENT CONCERNS INCORPORATED

WITH a capitalization of \$12,000,000 and a personnel consisting of some of America's best known farm implement manufacturers, seven large Eastern plants have consolidated and incorporated under the name of Bateman and Companies, Incorporated. The Bateman-Wilkinson Company, Limited, and its sister organization, the Bateman Mfg. Company, of Grenloch, New Jersey are the central figures in the new organization, Fred. H. Bateman becoming the president, Frank Bateman, Sr., becoming a director and vice-president, and Frank B. Bateman taking the post of secretary and assistant director of sales. The other officers of the new organization are: Philip N. Curtis of the Richardson Manufacturing Company, Worcester, Mass., vice-president and director of sales, and Frederick J. Hillman, of Springfield, Mass., treasurer.

In addition to the Bateman Mfg. Company and the Bateman-Wilkinson Company, Limited, the other concerns entering the consolidation are: The McWhorter Mfg. Co., Riverton, N.J., Duane H. Nash Inc., Millington, N.J., The Richardson Mfg. Co., Worcester, Mass., The Cutaway Harrow Co., Higganum, Conn., and Belcher & Taylor Agricultural Tool Company of Chicopee Falls, Mass.

It is understood that extensive plans have been made to take care of the increase in the demand for implements which they manufacture. The plans of the new corporation anticipate combining the manufacture of similar types of machines in its individual factories, each specializing in the making of the machines for which it is best known and adapted. The same men who in the past have been in charge of the various plants will remain in charge, retaining their close personal contact with their trade.

### FAIRBANKS-MORSE CATALOG

THE Canadian Fairbanks-Morse Co., Ltd., has just issued number 20 general catalog. It contains a complete list of the company's products. Particulars regarding design, dimensions and prices are given of oil engines, valves, pumps, electrical machinery, automotive equipment, scales, machine tools, etc.

WE GIVE  
"Quality and Service"

IN

TRACTOR and TRUCK  
STEEL CASTINGS

JOLIETTE STEEL CO., LIMITED

Tel. Main 402  
9th Floor, Read Building  
Montreal, Que.

JOLIETTE,  
P.Q.

## A 24-Hour Radiator Repair Service



Why fuss with troublesome radiator repairs? They can be more cheaply and effectively executed by the manufacturer. Ship any make to our Repair Department and in 24 hours, or less, it will be on its way back to you—freight or express as you instruct.

We promise you no wait service and A No. 1 workmanship.

**McCord Mfg. Co.**  
WALKERVILLE, ONTARIO



## A Complete Chain Drive Unit

**W**HILE the superiority of the chain drive for tractors and trucks has long been recognized, the introduction of the new Spaulding sprocket, *completing* the chain drive unit, makes it unequalled for service and durability.

All Spaulding sprockets are cut to a new tooth contour, designed and executed *exclusively* by Spaulding. This improved design so scientifically co-ordinates with the construction of the chain that it insures longer life, higher efficiency and less noise to the drive.

The big advantage to you in buying both chain and sprockets from Spaulding is that the same manufacturer assumes a definite responsibility for the *complete* chain drive unit.

Our new booklet is useful and instructive. A copy will gladly be sent upon request.

### SPAULDING CHAIN CORPORATION

*Fenton J. Spaulding, President*

Bloomfield, N.J.



**Spaulding**  
**ROLLER CHAIN**  
**& SPROCKETS**





## From such experience as this

Essex Tractors are the result of the combined knowledge of a number of men who have actually used tractors in the field. Their experience, plus study of Canadian farming conditions, plus the knowledge of our engineers has evolved a farm power unit that gives 100 per cent. efficient service.

# The "ESSEX" Tractor

is just the sort of tractor a farmer would design himself if we had the engineering ability.

But that's only one of the reasons why it is easy to show farmers that the "Essex" is best. There are a number of other "easy-selling," "Essex" reasons we can give you. Write for them.

**Essex Tractor Co., Limited**  
Essex - Ontario

### AUTOMOBILE HEADLIGHTS

W. A. McLean, Deputy Minister of Highways, has given notice to manufacturers of devices for the elimination of glare headlights, that those who wish to have such devices tested by the Department of Public Highways, in accordance with sub-section 4A of section 9 of the Motor Vehicles Act, are invited to submit samples at his office. Each device should be accompanied by a written explanation of its nature and adjustment.

Each application for test is to be accompanied by a fee of \$25.00 for examination and a further fee of \$25.00 will be charged for the issuance of a certificate.

### ARGENTINA A MARKET FOR AGRICULTURAL IMPLEMENTS

THE Statistical Department of the Anglo South America Bank, Ltd., has issued a bulletin dealing with the importation of all kinds of agricultural machinery and implements which should be of interest to manufacturers and dealers in implements. The report deals with agricultural supplies comprising machinery, implements, tools, etc., imported into the Argentine Republic during the last nine years, and shows the quantities of each separate line, place of origin and principal manufacturers custom house duties, and present market conditions. From a perusal of the report, manufacturers should be able to obtain sufficient information to enable them to decide as to whether the Argentine market is worth contending for and whether their products may be expected to compete successfully with the importations from other countries. The yearly average importations previous to 1914 were estimated at over \$9,000,000 gold. Of this total 70 per cent. was supplied by the United States, the British products showing very little energy and enterprise in competition. The imports during the years 1915 to 1918 show a falling off of over 30 per cent. as compared with the previous years, and the percentage supplied by the United States increased to 80 per cent. of the total imports.

A more detailed analysis of the imports and their origin shows that the United States predominate in machinery, implements and tools, with Great Britain a serious competitor with threshers, and Canada and Australia with reapers. Great Britain also supplied 35 per cent. of the picks and shovels, of which one-third was consigned to railways and public works; while scythes came from France and Germany, the former country also supplying potato and all other seeds. Of twine the United supplied no less than 95 per cent. Potato forks are principally imported from Great Britain, which also supplies 75 per cent. of the horticultural hoes, commanding the supply because of cheapness. As regards customs house duties, agricultural machinery was imported free of duty, with the exception of seeders and drills, fanning mills and hand cornshellers, up to October 1, 1917, since when a duty of 5 per cent. on value as per invoice has been imposed. Seeders or drillers pay \$1.16 gold each, fanning mills \$6.40 gold each, and hand cornshellers \$0.0075 cents gold per kilogramme. The report as to agricultural prospects states that record prices were realized for the 1918 wheat and maize crops, and it is calculated that in many districts the ground has produced during the year more than its intrinsic value. This should give a great impetus to agricultural enterprise, as a great part of the money will remain in the hands of the agriculturists who will endeavour to increase their plots under cultivation in the coming season, and the year 1920 might see a record for importation of agricultural supplies.

### I.H.C. PURCHASES PLANT

THE International Harvester Company announced recently its purchase of the American Seeding Machine Company's plant, Richmond, Ind., together with all the finished products, parts and raw materials on hand. The change of ownership became effective with the close of business on June 30, 1920.

Since 1912 the Harvester Company has been marketing the entire output of the Richmond plant under a jobbing contract, so the purchase will not in any way affect the distribution of the goods.

No change of personnel is contemplated at the Richmond plant. Beginning with July 1st, all employees of the American Seeding Machine Company, at the Richmond factory, will be Harvester Company employees. Mr. Willard H. Carr, vice president and Mr. Burton Carr, both sons of president James A. Carr, will come over to the Harvester Company and continue their activities relating to the manufacture of drills and seeders.

The Richmond plant covers nearly twelve acres of ground and at present has a working force of about 800. It makes the twenty-third Harvester manufacturing operation in the United States and Canada and the thirtieth in the world. Machines produced here have been and will be distributed through the Company's 93 branch houses in the United States, as well as through the Harvester branches and selling agencies in foreign countries.

By the present purchase the Harvester Company acquires one of the oldest and fullest lines of drills and seeding machines in existence, dating back 71 years. The nucleus of the Richmond plant was the Hoosier Drill Company, started by Joseph Ingels, a pioneer Quaker, at Milton, Indiana, in 1857, and organized as a stock company in 1867. It was organized in 1873 with John M. Westcott as the dominant figure and moved to Richmond in 1878.

When the American Seeding Machine Company was organized in 1903 it included, with other concerns, the Hoosier Company, the Empire Drill Company and the Kentucky Drill Company. The Empire Company was founded in 1849 by the Brown brothers at Palmyra, New York, and in 1855 moved to Shortsville, New York, the name "Empire" being then adopted. The Kentucky Drill Company began at Louisville, Kentucky, in 1855, as Brennan's South-Western Agricultural Works. In 1908 both these latter concerns removed their manufacturing to Richmond, becoming part of the American Seeding Machine Company's home plant, which was trebled in size for that purpose, the addition including two four-story warehouses, and up-to-date foundry, new power plant, more modern machinery and extensive new lumber yards.

### HAMILTON MANUFACTURERS PLANNING TRIP

AT a meeting of the board of directors of the Hamilton Chamber of Commerce, C. W. Kirkpatrick, industrial commissioner, explained to the board a plan for a tour through the Western Provinces for a number of Hamilton manufacturers by special train which would carry with it an exhibit of Made-in-Hamilton goods. It was considered that a trip of this kind would be an excellent advertisement for Hamilton and would do a great deal to promote harmonious relations between the manufacturers and business men of the East and West. The board of directors heartily endorsed this plan, and will appoint a committee to take the matter up.

### TOO GREAT A SHOCK

The chauffeur had been haled into court for speeding and running down a pedestrian.

"Your honor," said the chauffeur, "it was all my fault. The pedestrian was not to blame."

And the poor judge dropped dead.



# A Plug That Is Ripe From Hard Experience

*Joly Spark Plugs--over 5,000,000 of them--stood firm in perfect service on every Allied combat airplane during four years of war.*

Here it is—the thoroughly tested Joly Spark Plug—the one with the longest record of super-endurance against the high compression and sustained speed of the plug-killing airplane motor.

This plug is making the same tremendous records on Canadian and American truck, tractor, passenger car, marine, stationary and airplane engines.

In this splendid creation of design, material and construction lies your solution of the long-time question—

“Where can I find the perfect spark plug?”

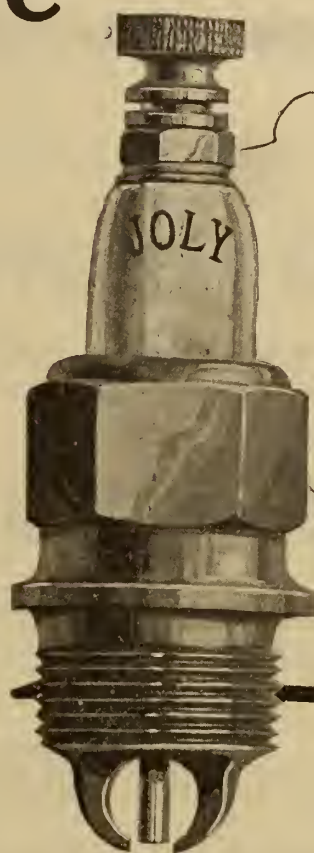

## Leaders of their Kinds in the World

The Joly Spark Plug will fire a leaner mixture than any other plug built. Compare the heavy integral milled fingers of the Joly with the slender fragile poles of other plugs. It is these fingers that cause the intensely hot, circular mass spark for which the Joly is famous.

The Joly has no leaky joints. You know what a vital advantage that is. This plug is compact, sturdy and simple in construction. From its central electrode to its cap it spells strength and unlimited endurance. Breakage is virtually impossible.

Joly insulation positively prohibits short circuits. And the heavy insulation is protected by a specially designed milled aperture wall, which also allows no oil leakage.

### Dealers:

A big proposition awaits the dealer who has the vision to swing his support to this comparatively new spark plug in this market.

Surely the plug that functioned perfectly on the Allied airplane motors—the only plug that stood the intense and sustained heat that these motors generated—can do the same wonderful work on the simple motors of your customers' cars.

How about a trial order?

List price Automobile type \$2.00. Airplane type \$4.00.

**Lyons Ignition Co., 215-219 Fourth Ave., New York**

Export Dept., Aggressive Agencies Co.  
35 Notre Dame St. East, Montreal, P.Q.

1 Madison Ave., New York City



Airplane Type



Automobile Type



# 4 Northern Electric FEATURES

## Klaxon Horns

Safety to pedestrians and car

## Gabriel Snubbers

Comfort on the roughest road

## Boyce Moto-Meters

Accurate knowledge of motor temperature

## Automobile Mirrors

Combine safety, comfort and appearance

Write our nearest House for Stock Shipment

**Northern Electric Company**  
LIMITED

Montreal      Halifax      Toronto      London      Winnipeg      Calgary      Vancouver  
Quebec      Ottawa      Hamilton      Windsor      Regina      Edmonton

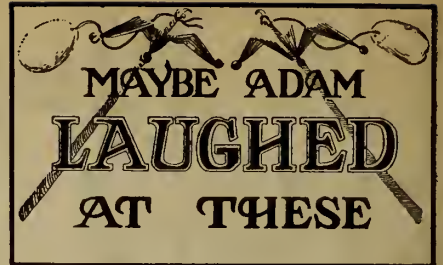

Chauffeur—There's the height of tough luck. Look in the road.

Passenger—Nothin' funny about a man fixing a puncture.

Chauffeur—Yes there is; he sells puncture proof tires.—Houston Post.

\* \* \*

Angler (describing a catch)—The trout was so long—I tell you I never saw such a fish.

Rustic—Noa. Oi don't suppose ye ever did.—Edinburgh Scotsman.

\* \* \*

A London bus driver had cut in ahead of a cabman rather awkwardly, bringing upon himself a tirade of abuse liberally sprinkled with profanity. The bus driver listened to it all with a good natured smile and then as he clicked up his horses he remarked: "That's what I calls 'avin a hornamental haddress presented to you."—Boston Transcript.

\* \* \*

Two Irishmen were working on the roof of a building one day when one made a mis-step and fell to the ground: the other fellow leaned over and called:

"Are ye dead or alive, Mike?"

"I'm alive," said Mike feebly.

"Sure yer such a liar I don't know whether to believe ye or not."

"Well, then, I must be dead," said Mike, "for ye would never dare to call me a liar if I were alive."

\* \* \*

"Why are you driving a mule instead of a horse these days?"

"I have to have something that could honk."—Kansas City Journal.

\* \* \*

"Did anybody comment on the way you handled your new car?"

"One man did but he didn't say much."

"What did he say?"

"All he said was fifty dollars and costs."—Baltimore American.

\* \* \*

Fish Coster—"Fresh! W'y, mum, ti breathed its last when it saw yer coming."

Customer (sniffing)—"And wot a breath it had.—London *Blighty*."

\* \* \*

Doctor—I bought a motor yesterday.

Friend—What sort was it—Diamler, Austin, Sunbeam, Omax, Simplex?

Doctor—No, but I know it starts with T.

Friend—Oh, it's a Ford, all the others start with petrol.—London Telegraph.

\* \* \*

Prof.—"What happened to Babylon?"

Fresh—"It fell."

Prof.—"What happened to Tyre?"

Fresh—"It was pnuctured."

\* \* \*

Informant, calling up a city editor—"I wish you would announce in the paper that the horse show has been called off."

City Editor—"Called off? For what reason?"

Informant—"Somebody has mislaid the horse."

\* \* \*

*The Last Look*—The wise pedestrian should take a look at the street before he tries to cross it, one reason being that he may never have another chance to do so if the motorist gets him.

Charles M. Schwab tells us to laugh at present-day troubles, so

Let's take our cue from Charlie Schwab And join the chuckling, laughing mob—

Ha! Ha! Bread's up another cent;

Ho! Ho! The landlord's raised the rent;

Hee! Hee! We'll soon be in a tent.

Ha Ha! Haw Haw! Hee Hee!

Our coal's to cost a fearful price. Ha! Ha!

We'll pay a whole lot more for ice. Haw! Haw!

And higher taxes—ain't that nice? Hee! Hee!

Now don't say things will cost still more.

(We got the giggles once before) We'd have hysterics—kick the floor— Tee, hee! Har Har! WOW WOW!

—Brooklyn *Eagle*

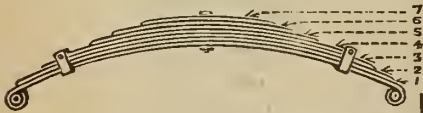

## AUTOMOBILE SPRINGS

The Guelph Spring and Axle Co.

Guelph, - Ontario  
Manufacture

**AUTO SPRINGS**  
ALL KINDS  
HIGHEST QUALITY

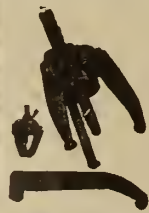

return to us and we will refund your money. We also make the GREB RIM TOOL.

THE GREB COMPANY, 319 State St., BOSTON

For repairing cracked water jackets, cylinder heads and split gas pipes, use

## ALUMALL METAL

the greatest crack filler known. Thousands of garages using it now, with great satisfaction. \$6.00 a box Sold Exclusively by

Geo. W. Anstett, - McGee, Sask.



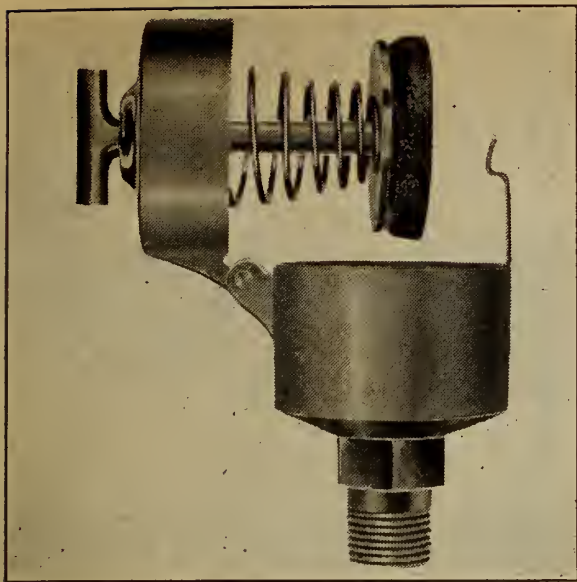

*A Baldwin Automatic Grease Cup opened, showing position of plunger when cup is empty. The tempered coil spring ensures uniform feed of lubricant at all times.*

## Why should he worry about lubrication

For Automobiles,  
Trucks,  
Tractors and  
Stationary Engines

The average farmer who buys a tractor, truck, automobile or stationary engine, knows mighty little about lubricating problems, and less about what lubrication neglect is liable to cost him.

Why should he? He's a farmer, not a machinist. You're the chap who, in Mr. Farmer's estimation, knows all about tractors and trucks, and machinery of all kinds.

Such details as lubrication equipment are strictly up to you, argues Mr. Farmer. "If the dealer sells me something that won't work, why, he's to blame, or the machine is."

So the easier it is for Mr. Farmer, to keep his tractor, or automobile, or truck, or stationary engine in perfect running order, the greater value will he get from these machines, the higher will be his regard of you, and the easier it will be for you to sell him more mechanical equipment.

And you know, the harder it is for him to neglect lubrication, the better, smoother, longer, more economically will his machinery operate.

**Baldwin Automatic Grease Cups make it almost impossible to neglect lubrication of important bearings.**

**They are entirely automatic. All the operator has to do is fill them occasionally—they will feed grease to the vital spot as long as there's grease to feed.**

**Simply and sturdily constructed of brass and steel. Few parts; practically trouble proof.**

**It will prove easier selling machinery equipped with Baldwin Cups, and they will mean greater satisfaction to your customers.**

**Let us send you all the particulars. Ask us all the lubrication questions you can think of.**

## The Specialties Company

228 Craig Street West

Montreal



# Automotive Accessories and Implement Equipment



## PINES WINTERFRONT

THE Winterfront is a device consisting of a set of drawn steel shutters for covering the radiator of an automobile in cold weather. It is manufactured by the Pines Manufacturing Co., 408-10 N. Sacramento Blvd., Chicago, who state the Winterfront protects the carburetor and intake manifold from the cold air blast which would otherwise be thrown against them. It makes starting easy and enables the motor to warm up quickly. Eliminates stalling and makes possible a quick get-a-way with full power. It also eliminates the long drive with the choker on, thus saving a considerable amount of gasoline and reducing the formation of carbon in the cylinders.

By entirely encasing the radiator, it conserves all the heat created by the motor until the radiator temperature has passed 130°. Then the Winterfront gradually opens and at 180° F. is wide open. It opens or closes automatically as required to maintain the most efficient temperature for best motor performance. The quickly warmed motor results in close fitting pistons preventing the escape of gasoline past the piston rings to dilute and destroy the lubricating oil supply.

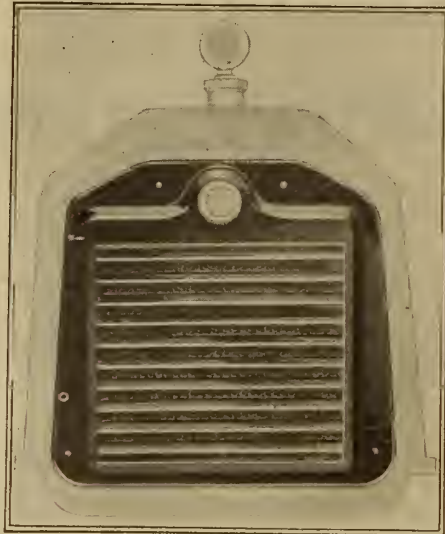

Pines Winterfront

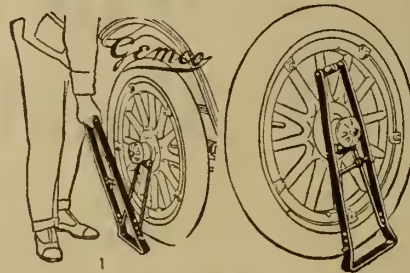

Tire Saving Jack

## GEMCO TIRE-SAVING JACK

THIS jack is made entirely of steel, except the hub saddle which is covered with heavy harness leather. The makers say they are easily placed in position and can be adjusted to fit different sizes of wheels. A secure lock holds the jack in place when the wheel is raised. They are finished in black enamel and manufactured by the Gemco Mfg. Company, Milwaukee.

## PEERLESS TOOL BOX

THE Corcoran Mfg. Co., Cincinnati, Ohio, have put on the market a tool box for Ford cars. This box is of convenient size, 22 in. long, 9 in. wide, and 7 in. deep. The makers say it is powerfully built and calculated to keep tools, chains and other valuable equipment carried by the motorist safe from thieves.



Veltum Pneumatic Valve Grinder

## VELTUM PNEUMATIC VALVE GRINDER

THIS valve grinder, with its pneumatic principle and throttle control, gives the operator any speed from 50 to 1,000 strokes per minute, making it unnecessary, the makers say, to go over a valve a second time. It operates on any pressure in the air tank and supplies enough power to grind any size of valve.

It also fits over-size valve stems into valve guides and grinds valve cages. Delicate work is also practicable with this grinder, such as grinding carburetor float valve stems and fuel system valves.

The machine is unusually light as all castings are made of aluminum. The manufacturer is the Warnock-Wirth Co., 624 South Michigan Ave., Chicago. The Canadian distributors are Cochrane-Stephenson and Co., Ltd., 602 Avenue Block, Winnipeg, Man.



Peerless Tool Box



Samson Fan Belt

## DUNLOP "SAMSON" FAN BELT

RECENTLY the Dunlop Tire & Rubber Goods Co., Limited, Toronto, Ont., put on the market their "Samson" Fan Belt for automobiles. It is a rubber belt, well shaped to fit the pulleys, and has been subjected by the Dunlop Company to most strenuous tests, including a soaking in cylinder oil for 500 hours at one time—usage considerably harder than the belt would ever be called upon to undergo. It came out of the oil, after its 500-hour soaking, the makers say, unimpaired and with its friction strength not one whit lessened.

By tests of similar rigidity, the Dunlop Company have proven that the tensile strength of the belt is greatly in excess of any strain that could be put upon it in actual service.

The belt is being made in various sizes to fit practically all cars made or used in Canada. As several makes of cars take the same size of fan belt, the Dunlop "Samson" is packed in boxes containing six of a size, each box bearing a label stating the size and the different cars that the belt will fit. In addition to the box label, each belt bears an individual label, similar to that on the box, to assist in case the latter should become displaced or effaced.

## TRI-CO SHOCK ABSORBER

THIS shock absorber for Ford cars consists of a clip fastener around the front axle which fits closely into the channel, and a bracket which attaches to the frame by removing the nut which holds the front lamp.

The device is made for both front and rear axles and is practically invisible when attached to the car. The makers say it adds to the comfort of driving and reduces the wear on the car by forming a solid yet flexible connection between running gear and the body of the car. It is manufactured by the Tri-Continental Corporation, Buffalo, N.Y.

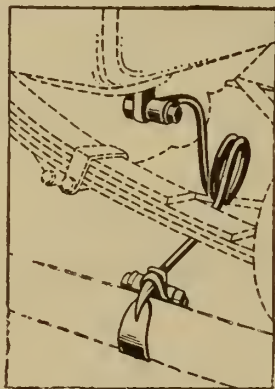

Tri-Co. Shock Absorber

## GEAR SHIFT LEVER EXTENSION

THIS is a device designed to bring the brake-lever handle on Ford cars six inches or so nearer the driver. The long reach required for the stock models is considerably modified by the Hughes extension, which places a ball grip at the point most convenient to the individual driver's arm length, the attachment being adjustable as to length.

It is distributed in Canada by Jos. St., Mars Company, Sterling Building, Winnipeg, Man.

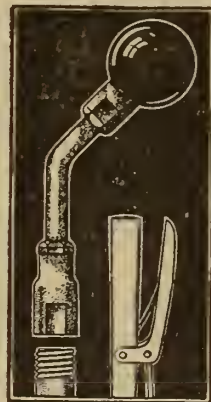

Adjustable Gear Shift Extension

## NO VALVE GREASE INJECTOR

THE Wood No-Valve grease injector is designed for pumping heavy grease direct from original grease barrel into gear cases and transmissions of automobiles, trucks, etc. The makers say it is quickly and simply attached to any grease barrel. The barrel is mounted on a special truck and can thus be moved to any part of the garage. The pump throws 1/4 pound of grease per stroke. A special non-drip nozzle instantly stops the flow when pumping ceases. The injector is manufactured by the Bennett Injector Company, Muskegon, Michigan.



Gear Shift Extension



Wood Grease Injector



**AN ARMY OF MOTORISTS NEED THESE ACCESSORIES.**

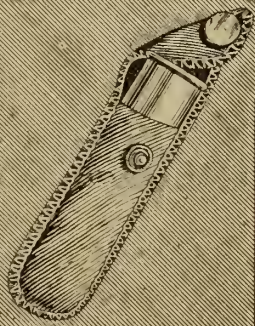

SCHRADERS  
AIR GAUGES



**They Should Be In Every  
Car Owner's Tool Box**

There is some good business for you, Mr. Dealer, in handling these accessories. Every car owner needs them. Keep a plentiful supply on hand of

- Gilmer Fan Belts
- Locktite Patcher
- Reliable Jacks
- Schrader's Air Gauges
- Rose Tire Pumps
- Weed Tire Chains
- Trex Rim Tools

Your customers will appreciate helpful hints concerning the accessories they should have. Demonstrate a Schrader Air Gauge for them. Explain how the Trex Rim Tool works. A supply of Locktite will enable a motorist to repair punctures at any time. As with all C. G. E. Automobile Accessories, these are

*"Tested for Service"*



LOCKTITE  
PATCHER

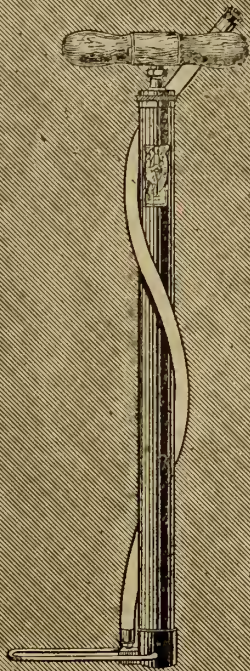

ROSE  
TIRE PUMP

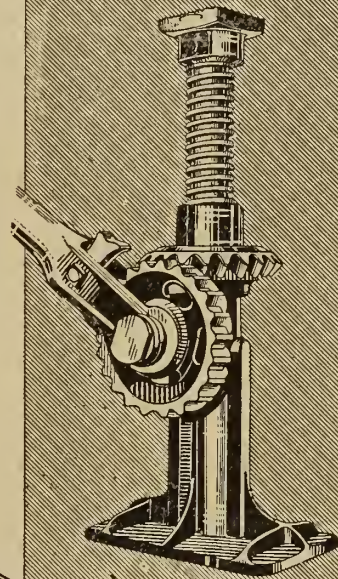

RELIABLE  
JACKS

**Canadian General Electric Company, Limited**

Head Office, Toronto

Branch Offices: Montreal, Quebec, Sherbrooke, Halifax, Sydney, St. John, Ottawa, Hamilton, London, Windsor, Cobalt, South Porcupine, Winnipeg, Calgary, Edmonton, Nelson, Vancouver and Victoria.



# Saskatchewan Dealers in Convention

## Lively Discussion by Auto and Implement Men on Auto Repairs Act, One per cent. Tax, Present Low Margins and Sales to Soldiers

THE annual general convention of the Saskatchewan branch of the Retail Merchants' Association was held in Moose Jaw on June 8, 9 and 10.

In view of the many important events that have taken place during the past year, especially in regard to the automobile and implement industry the convention was looked forward to by dealers with considerable interest. And it has since been voted by all who were present as one of the most successful conventions that has yet been held.

At the implement trade section meeting on Tuesday evening, June 8, Hugh Rorison, of Moose Jaw, Saskatoon opened a discussion on 'Present Day Margins.' He referred to the various companies operating within the province, and the margins allowed by them ranging from 8% to 13%, this in the face of an operating cost of from 16% to 20%. He called on the secretary, H. T. Pizzey, to substantiate his statements, who did so using a blackboard and illustrating the facts as told the meeting by Mr. Rorison. It was brought out during the discussion that there was really no incentive for the dealers to finance their own buying inasmuch as the discounts allowed for cash were not nearly adequate enough. The secretary stated that under one company's contract which was originally a wholesale one and was then changed to a "Farmers' Note Contract" the same goods, same year, cost the dealer approximately 8½% more than under the wholesale contract. In addition to this the dealer lost 5% cash discount, and more in some special cases. However, this shows roughly a loss of 13%. Then when this company issued a straight consignment contract with its cash discounts under which the dealers were allowed only 10% for relieving the company of a service for which they were originally charged 13%. Adding this 3% loss to the 13% already shown and we have a difference of 16% between the net cash price under wholesale contract and the consignment contract, when the paper is turned over to the company. In other words, for carrying the unsold goods and taking the farmers paper in lieu of cash, the company charges the dealers 16% and really about 16½% when worked out on the basis of net cash wholesale price. The penalty charged the farmer for extending the accommodation of credit to him on the same goods and in the same year was roughly 5%. The penalties were shown on the blackboard by the Secretary for the various companies operating in the Province which showed that while the company charged the farmer about 4½% for extending credit to them this year, the dealers were penalized from 8% to 12%. A very lively discussion in which all of the dealers present took part ensued and a resolution committee consisting of W. J. Keller of Shaunavon, G. W. Matheson of Craik and W. A. Harvey of Macoun were appointed to bring in any resolution necessary.

ON Wednesday, June 9th, at 9.30 a.m., the auto trade section met, when on the motion of W. H. Hamilton, seconded by J. LeBuldu, Mr. Funk of Herbert was asked to take the chair. Mr. Pickett then gave a very interesting address on the application of the Auto Repairs Act which was passed at the last session of the Legislature. He dealt with the Act, clause by clause, and made several suggestions as to amendments. A lively discussion ensued during which it was suggested that the word "Vendor" be amended to read "Manufacturer," and the interpretation of the said word "Manufacturer" should be extended to include any individual or company wishing to act as a distributor for the said manufacturer. C. Alexander stated that the Government expressed their opinion that they could not enact laws restraining trade. At this point the secretary pointed out that the Farm Implement Act of 1915 had the same effect as the Auto Repairs Act would have with the amendments as suggested, and therefore, could in no way be construed to mean a restriction of trade.

Another feature which Mr. Pickett dealt with at some length, was that the warranty does not have to be expressed in the contract but is only implied,

but the said contract must state a given point where repair parts may be secured. Mr. Pickett pointed out that to his way of thinking the dealers should have a contract prepared for use, which would nullify the provisions of the act and relieve the vendor of supplying parts for the cars, until the necessary amendments can be made to the Act.

The Resolution Committee brought in the following resolution:

"WHEREAS your committee believed that the Auto Repairs Act in its present form is unworkable, and not in the best interests of the vendor and purchaser of automobiles and repairs; we, therefore, recommend that the Retail Merchants' Association take the necessary steps to have this Act amended at the next session of the Legislature."

This resolution was put to the meeting and unanimously carried.

AT eleven o'clock, June 9th, the implement trade section again met when Mr. Matheson of Craik, opened the discussion on sales to soldiers, and stated the companies agreed to sell at cost when the arrangements were made, but that he found in every case save one where they were operating a straight consignment contract they were selling at net October 1st. prices and allowing the dealers 7% commission on this. This meant that the soldier paid from 3% to 5% more than the actual cost to the dealers under



Nice thing about these outfits is that you can thresh whenever you are ready—no expensive delays.

a cash transaction, which was the only way that the various companies would do business under the arrangements with the Soldiers Settlement Board. He further stated that there was no doubt that the companies were not entitled to this differential and in the face of this they were getting all the glory for being benevolent to the returned man.

Quite an animated discussion ensued and the opinion of the meeting was that the companies were deserving of censure for this action inasmuch as they had not lived up to the statements which they made when arrangements were entered into with the Soldiers Settlement Board.

On Thursday afternoon, June 10th, there was a general session and during the discussion of new business the point was raised by the implement dealers present that the absorption of the 1% sales tax inflicted considerable hardship on the retail implement dealers of the province, inasmuch as it consumed 10% of their gross earnings. It was further stated that under the present legislation the dealers were not allowed to make this additional charge to the purchasers inasmuch as the Farm Implement Act required the selling of goods of not more than the price filed with the Government. These points were substantiated by W. J. Keller of Shaunavon; G. W. Matheson of Craik and the secretary of the Implement and Auto Trade Section.

A very lively discussion ensued between the above and the Dominion President of the Association, J. A. Banfield, who was subsequently brought around to see the point of view of the retail implement dealers.

and suggested that the secretary wire the Dominion Secretary, and this was concurred in by the Implement Dealers present and the following telegram sent:

"A great injustice is done implement retailers by having to absorb percentage tax. Government here demand filing selling price and won't allow increase to cover tax. Manufacturers must absorb tax or gross injustice is done dealer. Letter following."

On Friday afternoon June 11th, a meeting of the provincial executive with the Government was held. The meeting was arranged in the interests of the retail implement dealers of the province for whom G. W. Matheson of Craik spoke. The subject was the absorption of the 1% sales tax imposed upon the dealers by the Dominion Government's Budget, inasmuch as this was passed on to them by the manufacturers and wholesalers. Mr. Matheson pointed out to the Government that under the present Provincial Legislation the dealers would have to absorb the 1% sales tax inasmuch as they were not permitted to raise the retail price as listed with the Government by the manufacturers and wholesalers doing business in the Province, as required under the Farm Implement Act.

He further pointed out to the Government the hardship this would bring about on the retail implement dealers of the Province stating that the present margins allowed to them ranged from 8% to 13% of the retail sales price and therefore the absorption of this tax would mean a loss of 10% of their gross earnings. A member of the Cabinet asked if it was not possible to have new lists filed and Secretary Pizzey stated that the manufacturers had no intention of doing so at the present time. The Government were quite sympathetic and fully appreciated what this absorption meant to the dealers, but pointed out that the Farm Implement Act did not control the retail price of implements but only repairs therefore.

The feeling of the Government was that the implement dealers would be justified in adding the tax to the listed retail price of the repairs.

THOSE present at this meeting were as follows: S. D. McMicken, Moose Jaw, Sask., S. E. Fawcett, Saskatoon, Sask., G. Garfield Wray, Regina, Sask., F. E. Raymond, (Provincial Secretary), Saskatoon, Sask., H. T. Pizzey, (Secretary, Implement and Auto Trade Section), Saskatoon, Sask., G. W. Matheson, Craik, Sask., W. J. Keller, Shaunavon, Sask., W. L. McQuarrie, Saskatoon, Sask., G. W. Anderson, Regina, Sask., F. A. Holden, Secretary, Moose Jaw, Sask., A. E. Tutter, District Secretary, Kerrobert, Sask., D. S. Saunders, District Secretary, Assiniboia,

### Interested in Canadian Journals

E. J. DODD, managing-director, the MacLean Co., of Great Britain, writing from London, says at the Canadian exhibition the MacLean business and technical newspapers and magazines were displayed at the stand of the Department of Overseas Trade, and that quite a number of copies were sold, mainly to persons interested in buying from Canada. One of these was a member of the staff of the Russian Bolshevik Trade Ambassador, who followed up the reading of the papers by a call on the MacLean newspapers' London office. It is difficult to know just what is going to happen in Russia, but one thing is certain, Russia cannot get on a normal producing basis without machinery, plant and industrial brains. The Jews who are controlling Russia know this, and there are bound to be developments favorable to Canada.

THE Etemal Battery Company of Winnipeg, has purchased the premises recently occupied by the O-Rib-O Manufacturing Company. The latter company has moved to a new site on Erin street.





Be a  
**Miracle Man**  
 Make  
**\$500 a Month**

**Miracle Men Make  
 \$125 a Week**

Here and now is your opportunity to make \$5,000 to \$15,000 a year. This new, scientific chemical discovery opens the road to fortune for a live man in each community. MIRACLE MOTOR GAS positively gives 15 to 40 per cent. more mileage from every gallon of gasoline used. It eliminates and prevents carbon,—the motor's worst enemy—makes engine run smoother and better in every way. At the present price of gasoline, think what it means to save from One-third to One-half on your gasoline bills. MIRACLE MOTOR GAS is one of the most sensational successes in the automobile field; motorists are amazed at its wonderful work.

**Tremendous Sales Possibilities  
 —Exclusive Territory  
 —Big Profits**

There are eight million automobiles in the United States alone. Add to this number the hundreds of thousands of stationary engines, motor cycles, trucks and tractors (both gasoline and kerosene) in use to-day. All need this wonderful product. You never dreamed of a better opportunity than this. Thousands in your county will want to economize on gasoline and will be eager to buy MIRACLE MOTOR GAS once they learn what it will do.

**Miracle Motor Gas  
 Guarantee**

We guarantee that MIRACLE MOTOR GAS, when used according to directions, will increase mileage from 15 per cent. to 40 per cent., eliminate and prevent carbon deposits, cut cost of fuel and make engine run better in every way. We guarantee that it contains no acids, alkali, camphor or ether, or other chemicals that could possibly injure any part or parts of the motor or other mechanism of the finest car.

We further guarantee to make good to any purchaser any injury to his engine caused through the use of MIRACLE MOTOR GAS.

(Signed) The Miracle Mfg. Co., Toledo, Ohio.

Reference: Commercial Savings Bank & Trust Co.

REPRESENTING AND SELLING  
**MIRACLE MOTOR GAS**

The Wonderful Chemical Discovery that Increases the Power of Gasoline FULLY ONE-THIRD  
*Big money-saver for the motorists; greatly increases mileage; saves gas; prevents carbon; makes engine run smoothly*

The motor world has been endeavoring to find a remedy for the high cost of gasoline. The seeming impossibilities of yesterday are the realities of to-day. The remedy has been found. It is here. It is MIRACLE MOTOR GAS. You will be amazed, astonished at the way this wonderful product increases the power of gasoline. An avalanche of letters from all over America proves its worth and testifies that it saves up to 40 per cent. of gasoline beside eliminating carbon. MIRACLE MOTOR GAS is used with gasoline. It is the combination of MIRACLE MOTOR GAS and gasoline that gives such phenomenal results. For example: if 100 gallons of gasoline gives you 1500 miles, 100 gallons of gasoline and one package of MIRACLE MOTOR GAS (costing \$1.00) will give you 2000 miles. This is equal to 33 extra gallons of gasoline (costing only \$1.00) or 3 cents for each extra gallon. MIRACLE MOTOR GAS is used in every state in the U.S. and in many foreign countries. We guarantee it to be harmless to the mechanism of your car. We guarantee results claimed for it or money refunded. Start using MIRACLE MOTOR GAS to-day and you will be delighted with results.

**A "SHOW ME" OFFER to Every  
 Motorist in Canada and America  
 One Package Miracle Motor Gas Free**

You, Mr. Motorist, can save One-third to One-half on your gasoline bills. To prove to you that Miracle Motor Gas will do this we make this liberal offer. Mail the coupon below to us with \$1.00. We will send you TWO \$1.00 packages (\$2 worth) with this understanding: If, after using them, you are not satisfied, tell us so, and we will immediately return your dollar; you don't have to return a thing. This offer applies on your first order only. Regular price of MIRACLE MOTOR GAS is \$1.00 a package.

Do you see what it means to be our exclusive Representative? It may mean your fortune. Delighted customers will boost it to their friends.

**Chemical Analysis**

Miracle Motor Gas is completely soluble in gasoline; leaves no sediment; contains neither acids nor alkali; cannot be harmful to engine; contains no oxygen, camphor, alcohol or ether; combustion properties are similar to high grade gasoline.

C. S. Morgan, Chemist,  
 536 Ohio Bldg., Toledo, O.

**Get Busy—We'll Help You**

No matter what the size of your bank account, if you mean business we'll help you. Why make the mistake of being a doubter and losing this opportunity? Our guarantee protects both you and your customers. Our proven sales plan and sales helps have assisted many a representative to big success. We furnish poster in four colors; circulars with your name imprinted thereon as our representative; sample packages of MIRACLE GAS; tell you how to secure a list of auto owners in your territory; show you how to advertise and sell; explain how to get and appoint sub-agents and in addition to all of this we spend thousands of dollars a year advertising MIRACLE MOTOR GAS from ocean to ocean. It is your privilege to cash in on this advertising.

To convince you beyond the shadow of a doubt as to the merit of this great chemical discovery, send us \$1.00 and we will send you TWO One Dollar packages of MIRACLE MOTOR GAS (\$2 worth) with the understanding that, after you have used them, if you are not entirely satisfied, just write and tell us so and we will refund your dollar. MIRACLE MOTOR GAS has demonstrated what it will do and now we want hundreds of live sales representatives. Send in your order for two packages, or if you prefer, just sign the coupon for complete information about this astounding product. Tell us what territory you want—we advise you to act quickly—representatives are being appointed rapidly. Better get the coupon on the way to us with a dollar by return mail. MIRACLE MOTOR GAS Duty Free in Canada.

**Clip, Sign & Mail TODAY**

MIRACLE MFG. CO.,  
 1307 Miracle Bldg., Toledo, O.

If your proposition is all you claim for it, would like exclusive agency for ..... District. Send for full particulars.

Enclosed is \$1.00 for two packages of Miracle Motor Gas (retail price \$1.00 each.) Duty free in Canada. If I am not satisfied after I have used them, it is understood that you will return my dollar.

Name .....

City .....

Province .....

**The Miracle Manufacturing Company**  
 SUCCESSORS TO CHAS. A. BUTLER & CO.  
 1307 Miracle Building - Toledo, Ohio  
 Reference: Commercial Savings Bank and Trust Co.



## THE BEST BUMPERS OBTAINABLE



"KABEE"  
SPRING ARM CHANNEL  
BUMPER

"LYON"  
RESILIENT BAR  
BUMPER

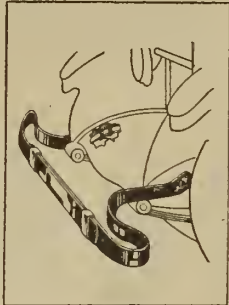

DURABLE BRILLIANT FINISH  
PATENTED "HOOKBOLT" ATTACHMENT  
FITS 90% OF STANDARD CARS  
OBTAINABLE FROM JOBBERS & DEALERS  
CATALOGUE ON REQUEST

**KINZINGER BRUCE & CO. LTD.**  
NIAGARA-FALLS, CANADA  
SOLE MANUFACTURERS, UNDER  
LYON CANADIAN PATENTS.



Tool Locked in Position  
for Removing or Replacing Tire

**K.P. Universal  
Rim Tool**

PRICE \$6.00

Sold by

**Northern Electric  
Company, Limited**

Montreal Ottawa London Regina Edmonton Toronto Winnipeg Calgary Vancouver  
K. P. Products Company, Inc., 250 West 54th St., New York City

The easiest way to remove tires from split rims. Collapses, holds rim collapsed while changing and forces the rim back on tire again with utmost ease.

## Cylinders Reground

We also manufacture Pistons, Rings and Pins, with special equipment adapted for this purpose. Also parts to order.

*We Do Oxy-Acetylene Welding*

**Advance Machine & Welding Co.**

177F Canning Street, Montreal

### SPAULDING QUADRUPLES PLANT

In order to take care of a greatly increased volume of business, the Spaulding Chain Corporation has taken over additional buildings formerly occupied by the International Arms and Fuse Works. This expansion quadruples the size of the original Spaulding factory, and provides for an enormously increased production. With this addition, the Spaulding plant, already one of the largest of its kind in the country becomes a dominating influence in the Roller Chain and Sprocket Industry. Although the Spaulding Chain Corporation has been in operation only a short period of time, they have struck their stride in production and are increasing their output each month.

### NEW "FRIEND" CATALOGUE

The "Friend" Manufacturing Company, pioneers in the sprayer field, have just issued their twenty-fifth anniversary catalogue. The line includes the following different model spray pumps: Model AX, 10 horse-power; Model DX, 4 horse-power; Model BX, 3½ horse-power and Model CX, 2 horse-power. These pumps vary in capacity from 5 to 20 gallons per minute.

The motors are of the auto-marine type; four cycle, jump spark ignition, positive machine cut gear drive between motor and pump. The larger outfits are all equipped with adjustable automatic throttle governor which works in an oil bath and regulates the motor to any desired speed. Another important feature is the unique pressure controller by which any desired pressure is maintained or instantly released. In the place of cumbersome spray poles, the "Friend" spray-gun is furnished which has a controlling valve enabling the operator to spray near or far with equal efficiency and greatly increased speed. Hyatt Roller Bearings are standard equipment on the main shaft and countershaft in the larger models and on the main shaft on the four horse-power pump.

### CALLS FOREMEN "STEERING GEAR OF PRODUCTION"

"YOU foremen are the steering gear and controls of production," said Mr. Edens, Factory Manager of the John Lauson Manufacturing Company, New Holstein, Wisconsin, which manufactures tractors and small gas engines, etc., in opening a course of training for the foremen and other supervisory executives of the plant. "Whatever the operating management desires to do, in whatever course it wishes to run production, it must guide and direct through you. The management controls the machinery and power of labor through you," he said.

The object of the course in Modern Production Methods inaugurated by the John Lauson Manufacturing Company, according to Mr. Edens, is to improve the relations of the management with the foremen and therefore the men. By developing in the foremen a wider outlook not only on the functions of their own departments but also on the work of the whole plant and of industry in general it is hoped that they will become more effective in their important position in production.

The course, the details of which are under the general supervision of Mr. B. F. Arps, is being studied by 49 of the supervisory force including factory manager, assistant superintendent, production manager, store keeper, foremen, general foremen, cashier, president, cost clerk, etc. These men meet regularly to discuss the fundamentals of modern industry and to apply them to the men's everyday problems. The subjects taken up

in the course cover the whole range of industrial organization and operation. The course brings out the importance of teamwork in the smooth working of industry; it teaches the foremen how to handle the employees under them so that the maximum harmony and efficiency will be attained; it also analyzes and discusses the most improved methods of factory organization.

### C. M. EASON REJOINS HYATT

C. M. Eason, formerly Manager of Tractor Bearings Division of the Hyatt Roller Bearing Company, and whom it will be recalled resigned that position early in the year to organize the Engineering Development Company of Moline, Ill., has again joined the Hyatt Organization in the capacity of vice president in charge of all sales with headquarters at the factory in Newark, New Jersey.

Mr. Eason is widely known throughout the Tractor Industry. He first became identified with Hyatt in February, 1914, and assumed the management of the Tractor Bearings Division in December of the same year. He is directly responsible for the broad-gauged, substantial policy of service and co-operation that has been responsible for Hyatts progress in the farm machinery field.

### OPEN NEW BRANCH

ANNOUNCEMENT is made by the Black and Decker Manufacturing Company, Towson Heights, Baltimore, Md., of the removal of their Philadelphia Branch Office from the West End Trust Building to more spacious quarters at 318 N. Broad street. The new office has a show window and show rooms, as well as a completely equipped service station. It is in charge of Branch Manager, W. C. Allen.

## Sell Holton Hood Clips for Chevrolets



They stop hood rattles  
They do away with the  
troublesome thumb screw.  
They sell at sight. Every  
Chevrolet owner is a prospect.

Quickly adjusted without  
the use of tools. Engine  
hood can be opened and  
closed in a second or two.  
Holton Hood Clips Never  
Slip. A real spring clip.

*Your Jobber Stocks Them*

Patented and Manufactured by  
**The Holton Hood Clip Co.**  
WINDSOR, ONTARIO



# VELTUM PNEUMATIC VALVE GRINDER

## Does the Job in Half the Time

This is not a claim. It's a proven fact, demonstrated by repeated tests of the Veltum Pneumatic. Flexible speed is combined with perfect control

Plenty of power to grind any size valve, and attachments to fit all styles of valves. Grinds valve cages as well as valves.  
Fits over-size valve stems into valve guides.  
Quickly relieves stuck valves.  
Does very delicate work, such as grinding carburetor float valve stems and fuel system valves.  
Grinds valves that have no provision for tool to fit in head.  
Grinds eighth valve on Ford engines.  
All castings are made of aluminum, which gives the machine unusual lightness.

Absolutely guaranteed to do the work and stand up.

The Veltum Pneumatic permits any speed from 50 to 1,000 strokes per minute, making it unnecessary to go over valve second time.

Does the entire job on a valve without stopping.

Operates on 15 to 500 lbs. of air from the air tank you now have.

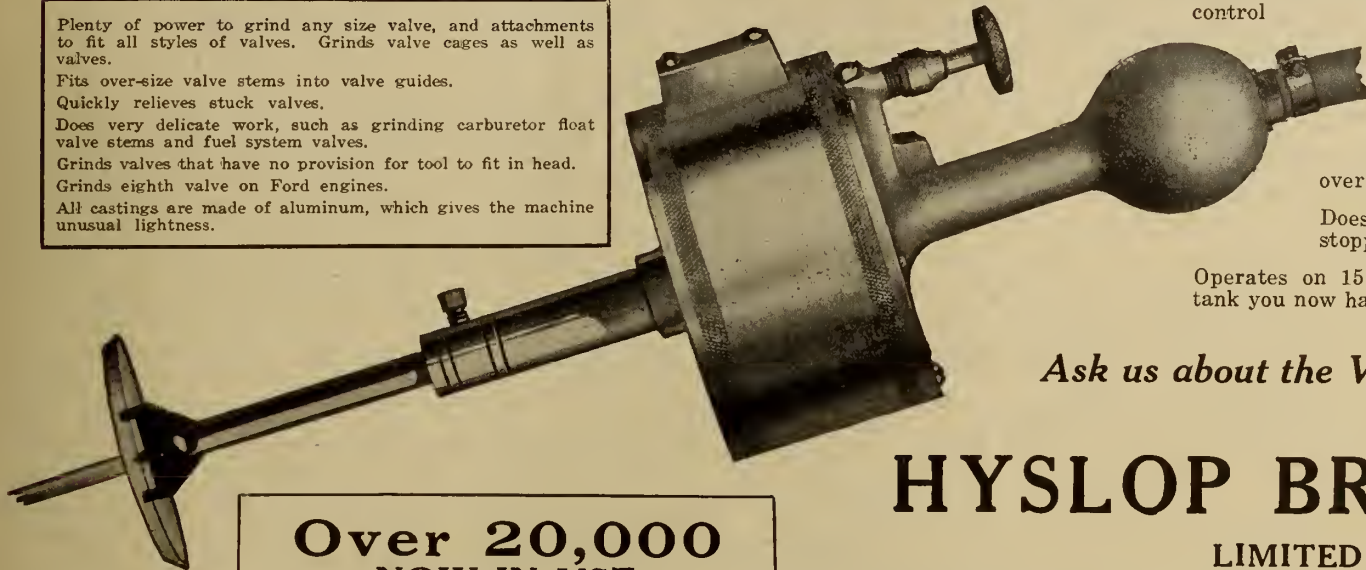

**Over 20,000  
NOW IN USE**

Ask us about the Veltum PNEUMATIC

## HYSLOP BROTHERS

LIMITED

Shuter and Victoria Streets

TORONTO

### Leaders Are in Great Demand

# "HEXALL"

Trade Mark Reg. U. S. Pat. Off.

## Socket Wrenches

WE ARE bending every effort to meet promptly the record-breaking demand for "HEXALL" Socket Wrenches and our factory is responding splendidly to the increased pressure that is being put upon it. But production follows certain well-defined, pre-arranged schedules where the maintenance of quality requires such unerring precision, such rigid adherence to standards of workmanship. Therefore, we urge all dealers and jobbers—

to keep their stocks complete on "HEXALL" Socket Wrenches. All indications point to an unprecedented volume of sales. *Don't be caught short.*

Dealers—get in quick touch with your jobbers. Jobbers—reach us.

"HEXALL"—comes in seven sets—a "HEXALL" for every need. Sold under this guarantee:

*"Break any Sedgley Wrench and We Repair it—No Charge"*

**R. F. SEDGLEY, Inc. Est. 1897**

Also Makers of "BABY" Hammerless Revolvers

2311-13-15 North 16th St., Philadelphia, Pa.

Canadian Distributors: Lamontagne, Limited, Montreal, Canada.

Harold F. Watson Co., Sole Agent: 208 Coristine Bldg., Montreal, Canada.



"HEXALL" Ratchet Socket Wrench  
No. 1—16 pcs.



"HEXALL" Ratchet Socket Wrench  
No. 2—11 pcs.

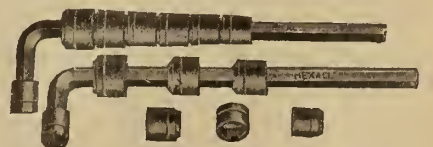

"HEXALL" Socket Wrench No. 5—  
8 pcs.





### SASKATCHEWAN FARM IMPLEMENT ACT

DURING the last session of the Saskatchewan provincial legislature an amendment to the Farm Implements Act was made regarding entries in contract forms as required by the Act. The existing law includes schedules in the form of contracts to be used for the sale of farm machinery, the contracts themselves containing several blanks. This act was designed to meet the condition where some companies were using the printed forms with the blanks for the interest rate filled in as "nine per cent."

The act now provides that all blanks in contracts under the existing law must be filled in in handwriting or else the contract becomes invalid.

### SASKATOON MOTOR CLUB STARTS CAMPAIGN

THE Saskatoon Motor Club has started a campaign to get new members and according to the indications it is going to be a great success.

The committee in charge of membership is out to get every car owner in Saskatoon to join the club. The membership fee is comparatively low, being set at \$10.

The membership committee is as follows: Sid Johns, Captain C. G. Parkin, E. J. Shaver, Fred H. Webb, Sheriff Calder, G. A. Stuart, Dr. E. C. Campbell, W. P. Bate, Thomas Underhill, Ralph R. Dill and A. A. Syman.

### MANITOBA RURAL CREDITS

THE Manitoba Government in 1917 passed an act designed to provide cheaper money for the farmer and thereby increase production. This act was called the Rural Credits Act and is based on the principle of co-operative credit and provides for the organization of Rural Credit Societies with government and municipal co-operation to secure short time loans at 7% for the members of each society at the security of crops, live-stock, implements, etc., purchased with the money thus borrowed.

In 1919, two years after the act became operative, there were thirty-eight societies which secured loans amounting to \$1,051,876. The purpose for which these loans were used in 1919 is shown in the following table:

Purchase of live-stock.....	\$172,532
Purchase of machinery.....	94,155
Seeding and harvesting crops	278,748
Breaking new land .....	247,691
Improvements .....	18,865
Retiring liabilities .....	56,742
Sundry items .....	183,143

There are 52 societies in operation this season.

### VERNON GARAGE REPAIR AEROPLANES

THE Vernon Garage located on Main street, Vernon, B. C., has an aeroplane repair department. The proprietors, H. B. Monk and C. L. Wraith were both in the R. F. C. and R. A. F. during the recent war and had considerable experience both in rigging and fitting.

July, 1919, Capts. Hey and Dixon flew from the coast to Armstrong for exhibition purposes and drove their machine to the very limit, which left it in a very bad condition. Hearing of the Vernon Garage they instructed them to put the machine in shape. This was undertaken by the Vernon Garage and in due course the airplane was turned out in first-class shape.

They pulled the engine out and thoroughly overhauled it, doing the same to the rigging. Capts. Hoy and Dixon were very pleased with the result and flew back to the coast without mishap.

Then again Lieut. Hall some days later landed on the Vernon Aerodrome and has his machine thoroughly looked over by the same people, and expressed entire satisfaction with the efficient manner in which these repairs were accomplished.

The Vernon Garage has been promised a lot of aeroplane work in 1920 by the above pilots, and in all probability Vernon will be a large landing ground for all machines flying from coast to coast or in any direction where Vernon can possibly be reached.

### B. C. TO FLOAT LOAN

HON. John Hart, Provincial Treasurer of British Columbia, addressing a meeting in Victoria, recently, said that he and the Government are considering the suggestion of local bond and financial men that a local loan be floated in B. C. so that the interest will remain in the province.

### DRIVE TO RIGHT IN B. C.

FOR some years the British Columbia Motor League has been strenuously advocating the "drive to right" system for all traffic on the highways and it seems as though its efforts are to bear fruit. The attorney-general has introduced a bill into the provincial legislature of British Columbia to make "drive to right the law of the province. The B. C. motorists are giving their support to the measure.

### ADVERTISING THE DOMINION BY FILM

CANADA is a country of vast agricultural and mineral wealth but the exploitation of her resources has been neglected principally on account of the lack of well directed propaganda disseminated with a view of giving immigrants, manufacturers, capitalists and industries, sound intelligent and comprehensive information in regard to the opportunities which abound. In advertising the multitudinous vital facts relative to the subject under notice, no better aid could be enlisted than that of the moving picture film, allowing as it does of the graphic presentation of every phase in such manner as could never be attained by the use of cold type. Sometime ago the Dominion Government created a moving picture bureau which had pictures taken of many of Canada's national industries for exhibition in Britain and other sources of immigration. The Hearst Government also established a bureau which procured many fine films of an industrial and scenic character, but so far there has been no movement to compel the theatre interests to exhibit the films, which is of course the essential part of the whole business. The British Columbia Government, has moved in the right direction by introducing in the Legislature a measure requiring all moving picture theatres to exhibit for fifteen minutes during each performance films provided by the Provincial Bureau. These films will be of an educative character illustrating the natural resources and economic and industrial problems of British Columbia, and also dealing with general Canadian events of interest.

In advertising the Dominion by film the Ford Motor Company of Can-

ada has at the present time two motion picture photographers travelling from coast to coast of the Dominion, securing topical material for reproduction.

### DETAILS IN STORAGE BATTERY SERVICE

Continued from page 14

to end, making a long, narrow battery, used chiefly on Overland cars. This battery in some cases has cell connectors the same shape as the battery, i.e., long and narrow with square ends. It might be thought the plate posts are square too, but this is not so. If a  $\frac{3}{4}$  hole is drilled at each end of this connector, it will lift off all right.

Then there are those posts which are swaged into the hard rubber top to make an acid-tight top. In this case the collar of lead must be cut away, either with a strong knife or a special tool, that the makers of the battery can supply. This tool is like a tubular drill which goes over the post and cuts around the sides. It is impossible to take the top off until this collar is removed.

Some batteries have a double cell cover; the inner one is formed in the shape of a trough and filled with battery seal to prevent leakage. A flat sheet of hard rubber with post holes and vent is placed on top while the seal is still warm. This makes a good tight top and a clean smooth finish, but has the disadvantage of taking a lot of seal and being hard to remove.

Most of the present day batteries have the single top cover made in the shape of an inverted trough, with seal run around the edges to make the joint. This one is easy to take down and to assemble, and is in general use to-day.

If a jar is found to be leaking, it must, of course, be replaced. The particular jar can be located before disassembling by watching which cell loses its electrolyte soonest.

If you do not have time to do this and are suspicious of them all, a certain test can be made by filling them up with pure sulphuric acid. Pure sulphuric acid will find a leak sooner than the acid of regular strength. Be careful in handling it as it is a powerful and destructive agent.

A simpler way is to fill all the jars with boiling water. This will soften the jars and open up the leak so that it is easily located. It also has the advantage of softening the jars so that they can be easily lifted out of the box.

When the leaky jar has been located, take two pairs of pliers with long flat jaws and grip the jar at the narrow ends firmly, as shown in the cut. Leave the hot water in and lift at both ends of the jar, steadily and without jerking. It may not come at first, but as soon as the water has been in long enough to soften the seal it will lift out easily without damaging the others.

SOME makes of batteries have a long bolt run from one side of the battery box to the other, pulling the sides of the box on the jars to hold them firmly without the use of seal. In this case, of course, it will be necessary to take out these bolts before trying to remove the jars. The heads of the bolts and nuts are flush with the sides of the box and are often placed under the lead name plate.

After the jar has been removed and it is still warm, it should be pressed into its right shape. As soon as it cools off it will become very brittle and hard to handle. Of course it can be softened by heating again, but if it is shaped up while still warm this leaves it in good condition for reassembling.

While the jars are out it is a good plan to give the inside of the box a coat of acid-proof paint, and in the case of jars fastened with bolts the inside should be well greased to make the jars slip in easily.

When a battery is torn apart and is to stand for some time, waiting for parts or for the owner's inspection,

everything belonging to it should be kept in one receptacle and tagged with lead tags bearing a number. A record of the customer's name and number can then be kept in the office or on the work order. It is useless to use the ordinary tags on battery work for the acid is bound to strike them at some time or other; if it doesn't ruin the tag it will sooner or later destroy the string it is attached with, putting you in a muddle with perhaps a dozen batteries torn down at once. Use lead tags with lead wire. Acid does not affect these and they can be used over and over again. In the long run they are much cheaper than the ordinary paper or linen tags.

### PLANNING FOR THE FALL CAMPAIGN

Continued from page 16

on display sample machines and implements that comprise his fall line, placed so that the prospective purchaser can examine them to his entire satisfaction. While many dealers are not fortunate enough to have sample floors they can, nevertheless, set up machines in their warehouse room or lean-to machine shed. No one likes to buy a machine without knowing how it looks and how it works.

THE fall implement trade should receive preferred attention from all live dealers not only because it offers sales opportunities for large machines such as tractors, threshers, hay balers, ensilage cutters, etc., that run into considerable volume even on a few sales, but also because of the fact that cash is more readily available from the farmer.

In case of a good crop the farmer naturally feels prosperous. He has the proceeds from a good share of the crop tucked away safely in his local bank and feels better able financially to buy new equipment than before harvest when his crop was still an uncertainty. And as the farmer improves his operating equipment he increases at the same time his production efficiency and capacity for handling bigger crops. Thus the dealer who sells implements intelligently is helping along not only HIS own prosperity, both present and future, but is also constructively assisting the farmer.

### KITCHENER GETS COMMERCE TRUCKS

THE Commerce Truck Company has decided to locate in Kitchener and not Guelph as stated formerly. The Commerce Company made a proposition to the Kitchener Board of Trade which was endorsed by that body. The truck company's proposition included the erection of houses along with the factory. Kitchener citizens are interesting themselves in the enterprise. Securing local capital is one of the important details of the scheme.

### Good Position Open

One of Canada's largest and most aggressive manufacturing organizations desires to engage a representative between the ages of twenty-eight to thirty-five to extend present connections in special lines for the automotive industry; to introduce and develop special lines offering sufficient volume to justify mass production. Mechanical ability desirable but not imperative. The opportunities are unlimited for one with the necessary executive ability and initiative. Apply with full particulars of age, experience, and salary required to Box 100. Motor, Tractor and Implement Journal, 143 University Ave., Toronto, Ontario.



# TURNER Simplicity

Leave a good name behind at every sale

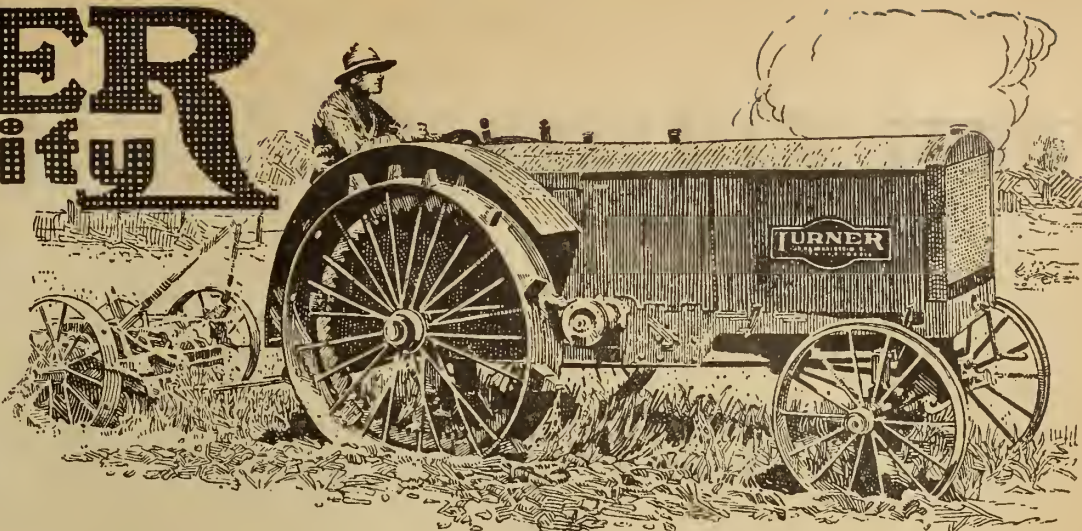

No matter where you sell a Turner Simplicity Tractor, nor for what kind of farm job, you can go back at any time and find it satisfactory. The longer your customer uses it, the more he is going to boost you.

That is why the best distributors, all over this country and Canada, are pinning their faith to it. It is the thing that has made the Turner Tractor break all speed records for sales increase in the past two years.

Surplus power without excessive weight, quick moving, quick turning, adaptability to all kinds of belt jobs, kerosene or gas burning, thorough protection from dust, these and dozens of other qualities are responsible for this smashing sales record

Get all the facts before sales arrangements are made for your locality. Write or wire today

Turner Manufacturing Co., 441 Lake Street, Port Washington, Wisconsin

DISTRIBUTORS:

The Turner Tractor Sales Co.  
WINNIPEG, CANADA



Power Farm Machinery Co.  
EDMONTON, ALTA., CANADA

The Practical Tractor

*Aikenhead's*

"The Sign of Better Service"

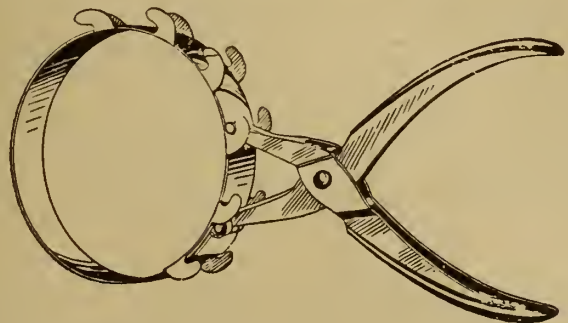

## The Victory Piston Ring Compressor

This compressor is the only tool that is instantaneously adjustable to fit all size piston rings, from 2 inches to 5<sup>7</sup>/<sub>8</sub> inches in diameter. Can be used on all type motors for inserting piston into cylinder.

To operate: Insert piston into cylinder, place steel band of compressor on piston rings, compress and push piston into cylinder. Entire operation completed in ten seconds.

This tool should be in every mechanic's tool kit.

Aikenhead Hardware, Limited

Toronto, Canada

## The Plug with the Hotter Spark



The ball point of the "M&S" spark plug concentrates the current and intensifies the heat. This gives a sure, hot spark—producing better combustion and greater power.

The "M&S" plug is made in all styles to suit every make of car—it is standard equipment on the popular new Overland "4."

The "M&S" plug is made in Canada and guaranteed to give complete satisfaction.

Dealers:—Ask your jobbers for the "M&S" plug.



SPARK PLUGS

"Made-in-Canada"

No.	Models
500— <sup>1</sup> / <sub>2</sub> "	Standard
501— <sup>7</sup> / <sub>8</sub> "	Standard
502— <sup>7</sup> / <sub>8</sub> "	Long
503— <sup>7</sup> / <sub>8</sub> "	Long with Chevrolet Terminal
506— <sup>1</sup> / <sub>2</sub> "	Long
504—Regular	Porcelain
505—Chevrolet	Porcelain.

Machine & Stamping Co., Limited

1209 King Street West, Toronto, Ontario  
Commercial Dept., Russell Motor Car Co., Limited



# STEEL CASTINGS

for

# TRACTORS

CANADIAN  
STEEL FOUNDRIES  
LIMITED

General Sales Office:

Transportation Building  
Montreal

## BIRDELL CLOVER HULLERS

Best for Threshing,  
Hulling and  
Cleaning

Little Red or Common Clover Seed  
Big English or Mammoth Clover Seed  
Alsike Clover Seed  
Sweet Clover Seed



### THREE SIZES FOR CANADA

No.	Cylinders	Capacity	Power Required
No. 2	27" x 32"	3 to 5 bushels per hour	6 to 8 H. P.
No. 1	30" x 36"	5 to 7 bushels per hour	8 to 10 H. P.
No. 8	40" x 52"	7 to 10 bushels per hour	10 to 12 H. P.

WE HAVE A SIZE TO SUIT EVERY NEED

## ANN ARBOR HAY PRESSES

If in the market for a Hay Baler we can  
furnish in any size to meet your requirements.  
Write us or call and see us while in the city.

**Birdsell Manufacturing Co.**

Foot of George Street  
Toronto, Canada

### TRACTOR MINUS TWO MEN AND SIX HORSES

By W. D. SHIPLEY

"THE small cost of maintenance and the splendid performance of my tractor the first year was a surprise to me," said Mr. G. C. Channon of Oakwood, Ontario, when asked what kind of service his tractor had been giving him.

"My tractor displaced two men and six horses and all the expense that goes with them. Isn't that a money and trouble saver. When I got it in the spring of nineteen I imagined there would be something going wrong all the time, but the tractor proved otherwise. It required practically no repair work last summer and was never touched till I overhauled it this winter. The cylinders were very slightly carbonized due to using gasoline which is the cheapest in the long run.

"The Cleveland develops about 12 horsepower on the draw bar and twenty on the belt. It generally takes the place of six horses in the field. With three ploughs I usually plough from five to seven acres a day. With seven sections of harrows I can harrow from eight to ten acres an hour. The performance of the tractor on the binder shows its great advantage over the tired horses sweating and tugging on a hot day. The tractor doesn't have to stop a hard day's work at six. There is not the annoyance of controlling restless fly tortured horses. Just touch a little lever and you can leave the tractor anywhere in the field, and it is very nice at meal times to run into the house without feeding and watering the horses. You can always depend upon the tractor on the hottest day, and you don't have to give it a rest as often as horses.

"I am able to get on my land as early if not earlier than the horses. My land being so level is very suitable for a tractor, but I believe the little Cleveland would give excellent service on rolling land too. Last summer when the intense hot weather held up a lot of farmers from preparing their corn ground I was able to keep at mine with the result of a good start and a heavy crop in the fall.

"I like the caterpillar type very well. It has more bearing according to weight and lighter according to horsepower. It can be handled about the same as a team of horses and turned in a twelve foot circle."

### APOLLO OFFICE IN TORONTO

THE Apollo Plug Manufacturing Company, Ltd., of Birmingham and London, England, are making arrangements to open a head office in Toronto from which centre they hope to render the trade the best service possible.

G. D. Smith, the expert manager of the company, is now in Canada undertaking a service tour. It is expected that the Toronto office will be functioning in a week or two.

The Apollo Spark Plug Co., recently opened a service depot at 84A Gt. Tichfield Street, London, W.I., to take care of the company's overseas trade and to facilitate transit abroad and also to provide a reception and information bureau for Canadians and Americans who might happen to be in London.

The advent of the Apollo products in Canada is another instance of a British organization bringing its manufactures and service aid to our very doors.

### I.H.C. VICE-PRESIDENT PASSES

PHILIP Sidney Post, vice-president of the International Harvester Company, died recently at his home in Winnetka, Ill., after a brief illness.

Judge Post was appointed General Attorney of the Harvester Company in 1910, having previously served two years as assistant to the Corporation's

general counsel. After eleven years of arduous, important and constructive service in the law department, he was elected in May, 1919, to a vice-presidency in the Harvester organization, with special executive duties, including full charge of the Company's public relations.

He had been for several years a trustee of Knox College, his alma mater, and took a prominent part in its recent commencement exercises. He was a member of the Loyal Legion, of the American and Illinois Bar Association and of the Union League, University, Hamilton, City and Law Clubs. He is survived by his widow, a sister, Mrs. James C. Simpson of Galesburg, Ill., and a brother, Maj. William S. Post, of Los Angeles, Calif.

### TRANSPORTATION AND THE MONEY MARKET

INCREASED discount rates can hardly be expected to do more than check further borrowing, according to the National Bank of Commerce in New York, until the railroad situation improves so as to permit prompt liquidation of commercial and agricultural credits. In its money market discussion in the July number of its magazine, Commercial Monthly, the bank declares that the present partial breakdown of transportation, by interfering with the movement of products, has prevented the liquidation of a tremendous volume of credits such as is normally effected at this season of the year.

"During the period from May 16 to June 15," the bank points out, "the money market has experienced continued tension which, largely as a consequence of the traffic situation, had become pronounced during the preceding month. The strain on credit facilities has been reflected in a further general advance in money rates. While some improvement of the traffic situation, mainly potential rather than actual, has been accomplished, it has not proceeded sufficiently to release any considerable part of the credit which had been looked up, and traffic conditions can be expected to improve only slowly. Meanwhile, the credit requirements of a new crop movement will become pressing in the not distant future.

"Until the railroad situation improves sufficiently to afford an adequate physical basis for the prompt liquidation of commercial and agricultural credits, the increased discount rates adopted by many of the Federal reserve banks can hardly be expected to do more than check further borrowing; thereafter, they should be a strong influence in effecting a curtailment of outstanding credit, in preparation for the heavy autumn requirements."

### EXPORT CHASE TRACTORS

THE announcement that the export business of the Chase Tractors Corporation is rapidly increasing, strengthens the opinion that high grade tractors will soon be in universal demand.

Already the Chase Corporation have filled orders received from the Anglo Brazilian Exploration and Trading Company of Rio de Janeiro, Brazil and during the month of June will ship machines to both England and Jamaica.

The Chase Tractor is built in Canada by Canadians, and is reputed to be one of the highest grade tractors made.

### BUY CANADIAN SEEDS AND MACHINERY

THE Eastern Counties Farmers' Co-Operative Association, Ltd., of Ipswich, England, are buyers of Canadian grown agricultural seeds, such as alsike, timothy, lucern and red clover. The Association has a separate department dealing with machinery, implements and hardware.



BUILT IN CANADA



*Catalogue and Performance Data on Request*

Openings for Live Dealers in the  
Province of Quebec

BUILT BY THE  
EASTERN CANADA MOTOR TRUCK CO., LTD.

HULL, - QUE.

DISTRIBUTORS FOR

WEST ONTARIO, MANITOBA, SASKATCHEWAN, ALBERTA AND BRITISH COLUMBIA

COMMERCIAL CARS, LTD.

TORONTO, LONDON, WINNIPEG AND VANCOUVER



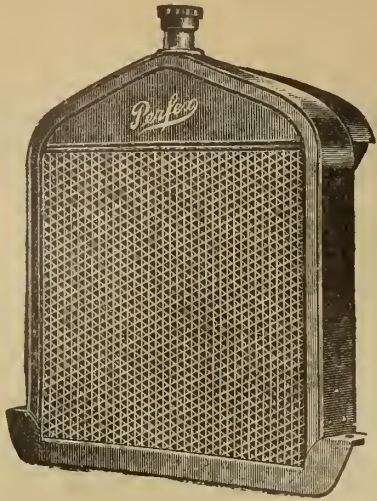

# PERFEX

## The Perfect Radiator

Perflex radiators for Fords are a quality product embodying features that cannot be had in other radiators.

A patented spring bracket suspension and a real radiator core of great efficiency.

*The last word in Radiator construction*

**Perflex Radiator Co., Racine, Wisconsin, U.S.A.**

**P. A. C. McINTYRE & COMPANY**  
311 Confederation Life Building, Winnipeg  
Direct Representatives for  
Manitoba, Saskatchewan, Alberta and British Columbia

### DEALERS MUST ORGANIZE

**H. T. PIZZEY**, secretary of the auto and implement trade section of the Saskatchewan Retail Merchants Association, at the recent convention of that association in Moose Jaw in his address to the auto and implement dealers, emphasized the need for organization to obtain amelioration from conditions existing in the trade to-day. He said in part:

The retail implement dealers are essential and necessary to every community, and they can never be dispensed with. No mail order or co-operative concern can give the same service that the dealer can and this service is demanded by the farmers. This is borne out by the statement of the general manager of the United Grain Growers' Association in his report in which he says, "When our machinery department was first started, the aim was to handle machinery with the least possible expense in order to make the spread between manufacturers price and the price to the farmers as low as possible. It was not long before we found that this method of doing business was not satisfactory to either our shareholders or the patrons of the company. As the business has developed, the demand for increased service has grown until at the present we find ourselves doing what is practically a semi-retail business at our elevator points."

We have no age limit, no restrictions and no compulsory methods, but all that is required is the desire on the part of the individual dealer to line up with us and his fellow retailers. As an individual dealer you are only a unit, but by becoming united and associated with your fellow merchants, you become part of a strong factor, and a representative in a large and influential organization. The cost per annum is small you are required to pay and it is as necessary as a fire in-

surance policy with the advantage that you pay a much smaller premium.

There are approximately 1,300 dealers in implements and autos throughout the province of Saskatchewan and there is no reason why we shouldn't have 100% of these in our trade sections. At the beginning of the year there were 250 members and this has now increased to approximately 300. The idea in view when this was inaugurated was that it would be possible to circularize every dealer in the province, irrespective of being a member of the association with matter appertaining to the lines which he handles. It is also expected to devise some system of accounting, which will establish once and for all times, the exact cost of operating.

In concluding I must reiterate that if we are to obtain results we must have the co-operation of every dealer in the province, and must have his support both morally and financially. Your Provincial Committee have spared no efforts since their appointment, and in more than one case have neglected their business to do so, and some results of the meeting with the wholesalers can already be seen, in the increases of repair commission allowed this year.

### FARMERS USE MOTOR TRUCKS

**ACCORDING** to statistics just compiled in the United States, farmers in that country are the largest users of motor trucks. In 1917 there were 79,789 motor trucks engaged in hauling farmers' products. Manufacturers came second in the list with 73,928 and the retail merchants third with 71,486. It is estimated that during the year 350,000,000 tons of farmers' products were handled by motor trucks by U. S. farmers and truck gardeners.

Investigations in the United States show that the per ton mile cost of hauling wheat and corn with motor

trucks averages 15c, as compared with 32c with horses. In the South, hauling cotton with horses costs the planter 48c per ton mile, while the motor truck performs the same service for 18c per mile.

### QUEBEC PROVINCIAL MOTOR LEAGUE

**THE** first annual meeting of the Quebec Provincial Motor League was held recently at the Chatcau Frontenac, Quebec. The following delegates were present: A. L. Caron, president, and Geo. C. McNamee, Montreal; W. S. Bullock, M.P.P., and A. C. Smith, A. Girard and Barin, Granby; J. A. Brillant and W. L. Veit, Matane and Rimouski; Dr. P. Picard, A. Chateauvert, Hon. Frank Carrel, and L. C. Beaupre, Quebec.

The president in his report referred to the formation of local clubs. The question of drivers of vehicles carrying lights after dark was also referred to and in this connection he said in part:

"The old excuse that the farmers are opposed to such a measure is now antiquated; the farmers are motorists as shown by the statistics which disclose that the majority of autos to-day in the province, are owned outside of urban centers, consequently we should see that our Provincial Legislators enact upon the statute books, suitable legislation making it obligatory for the protection of life and limb that all vehicles carry a light after dark, or else keep off the highways. There is no use beating about the bush any longer, and I would further draw your attention to the fact that this is not an amendment to the motor vehicle law, it is already included in the act so far as motor car owners are concerned, but it is a matter for enactment in the general laws of the province, and we should consult the Attorney-General in the matter immediately."

### SUCCESSFUL SALES CREW

**A** CREW of ten salesmen of the Champion Spark Plugs Co., of Canada, Limited, has just completed a successful campaign in the city of Montreal. Their work during the past two weeks has been of more than passing interest, owing to the fact that the methods adopted represent the last word in modern intensive merchandising.

The campaign was inaugurated with a zone meeting and dinner, which were held at the Old Colony Club at the Windsor Hotel. Mr. J. B. Walden, Territory Manager, gave the representatives an address on Canadian conditions and the selling points of their product. A more elaborate address was given by Mr. B. W. Ruark, the Sales Instructor of the Company, on the subject of "Intensive Selling Plans." It is interesting to note that this crew of salesmen are all Canadians.

### LAUSON NEWS

**THE** Goodwin-Buquors Motor Co., one of the pioneer implement and tractor distributors in the rice fields, has contracted to distribute the Lauson Tractors in the following counties in Louisiana: St. Martin, Lafayette, Iberia, Vermilion and St. Mary.

The appointment of the Central Equipment Co. of St. Louis, to distribute Lauson Tractors in eastern Missouri and southern Illinois is announced. A supply of tractors and parts has already been ordered forward to St. Louis.

D. K. Arstad, director of Kullberg Co., Christiania, Norway, who has been distributing Lauson Tractors and engines over a period of eleven years, was a recent visitor at the Lauson factory.

Mr. Arstad is enthusiastic over the prospect of a good tractor in the Scandinavian countries and states that it will be a long time before the German

manufacturers will be able to successfully compete with American machines. He is on an extended visit in the United States.

M. A. Macbeath of the Casacarter Co., S. A., Havana, Cuba, recently called at the Lauson factory and arranged for next year's specifications on tractors and engines. Casacarter, S.A., Havana, Cuba, of which Mr. Macbeath is director, is one of the most important tractor, engine and machine distributors in Cuba.

Harry Lane Morris, who formerly had charge of the sale of Cleveland tractors in Georgia has taken charge of the Oklahoma territory on Lauson tractors. Mr. Morris is a well known figure in tractor and automobile circles and his wide acquaintance at Oklahoma assures active Lauson representation there.

The John Lauson Mfg. Co., has opened up a factory branch at 1739 Walnut St., Kansas City, Mo. A complete stock of Lauson tractors and repairs will be carried. The branch will be in charge of Geo. D. Ash, who has been representing the Lauson factory in the capacity of Eastern District Sales Manager for a number of years.

### TORONTO WILL WELCOME GOOD ROADS ENTHUSIASTS

**THE** tourists of the Michigan Pikes Association will leave Detroit on July 14 and will reach Toronto July 16. They will be the guests of the city of Toronto and the Province of Ontario at a banquet to be given at the King Edward Hotel on the night of July 16.

The banquet will be attended by members of the Ontario Cabinet, including the Premier, Hon. E. C. Drury. After the banquet a mass meeting, advocating good roads, will be conducted in Queen's Park.

G. A. Hodgson, president of the Ontario Motor League, will be chairman of the mass meeting. G. R. Graham, sales manager of the Pierce-Arrow Motor Car Company, Buffalo, will speak for the Michigan visitors.

In the event of inclement weather Hon. F. C. Biggs, Ontario Minister of Public Highways, has made arrangements with the Provincial Government to throw open the Parliament Buildings to the good roads enthusiasts.

### ATTENDS ACCESSORY EXHIBIT

**O. P. MOUND**, president of the Burd High Compression Ring Co. of Rockford, Ill., attended the accessory exhibition held recently in Del



O. P. Mound

Monte, California. Mr. Mound returned to Rockford through western Canada.

In company with J. H. Dixon of the Burd Ring Sales Co., Ltd., of Canada, he visited the various branches of the company situated at Calgary, Edmonton, Vancouver and Regina and also visited the Canadian headquarters of the Burd Co., at Winnipeg.



# HYATT

## ROLLER BEARINGS

### For Abundant Harvests



**H**YATT Bearings are built on a principle fundamentally correct—carry the severest loads under all conditions without wear on the rolling parts and never require adjustment.

Because of their greater capacity for lubricant they require less attention for oiling than any other bearing.

The unequalled quality of Hyatt Roller Bearings has been proved by actual and successful use in almost every application in which an anti-friction bearing can be used.

**T**O make harvests more abundant—to make farm profits larger—to make farm work easier and farm life happier—these are the achievements of power farming machinery.

And it is highly significant that in the best of these machines whether they be trucks, tractors, plows, threshers or other agricultural implements, you will find one constructional feature in common—Hyatt Bearings.

This universal use of Hyatts expresses the combined opinion of hundreds of manufacturers and thousands of farmers who have proved to their own satisfaction that Hyatt Bearings make better farm machinery.

#### HYATT ROLLER BEARING COMPANY

Tractor Bearings Division  
Chicago

Motor Bearings Division  
Detroit

Industrial Bearings Division  
New York City

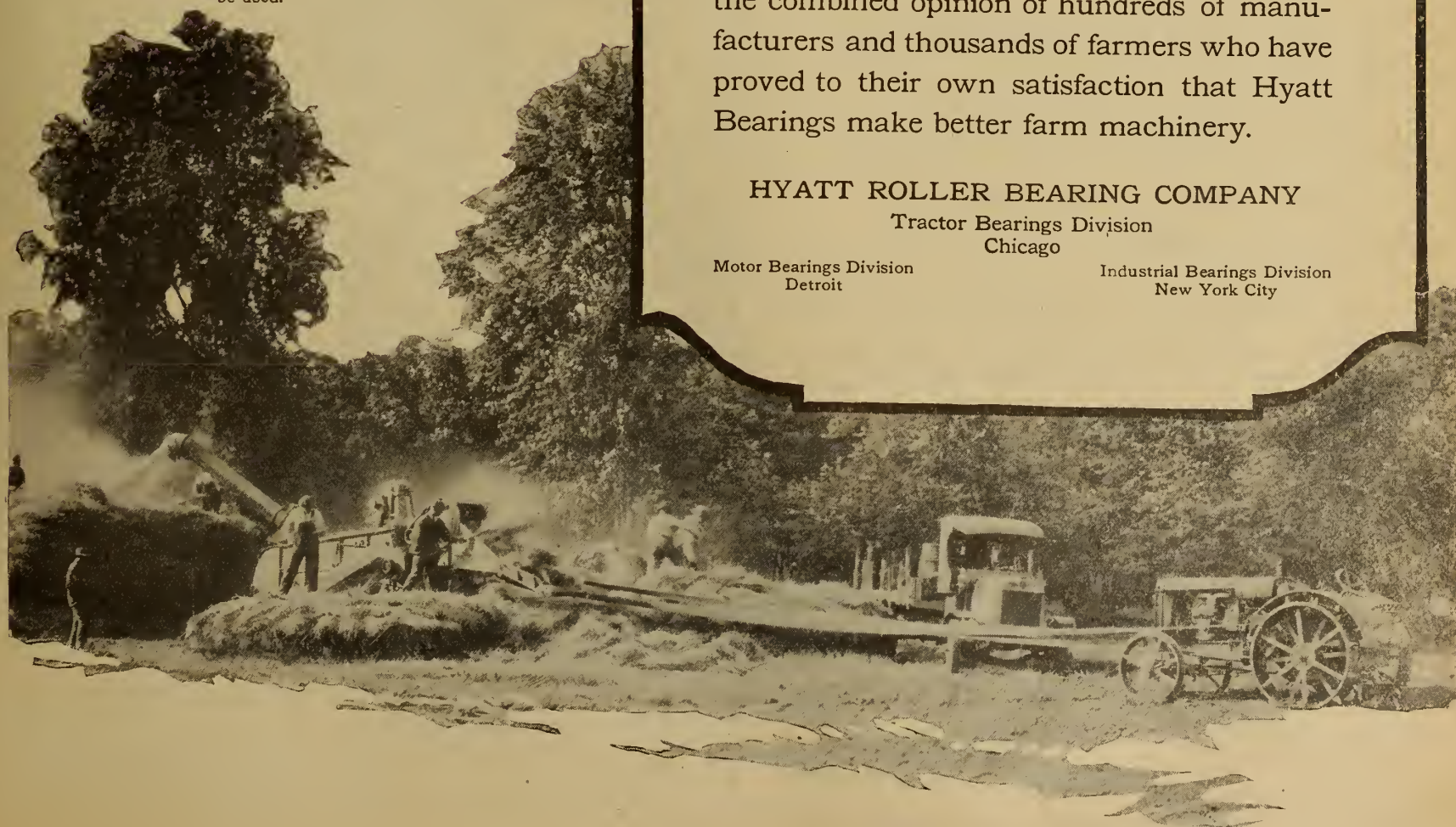



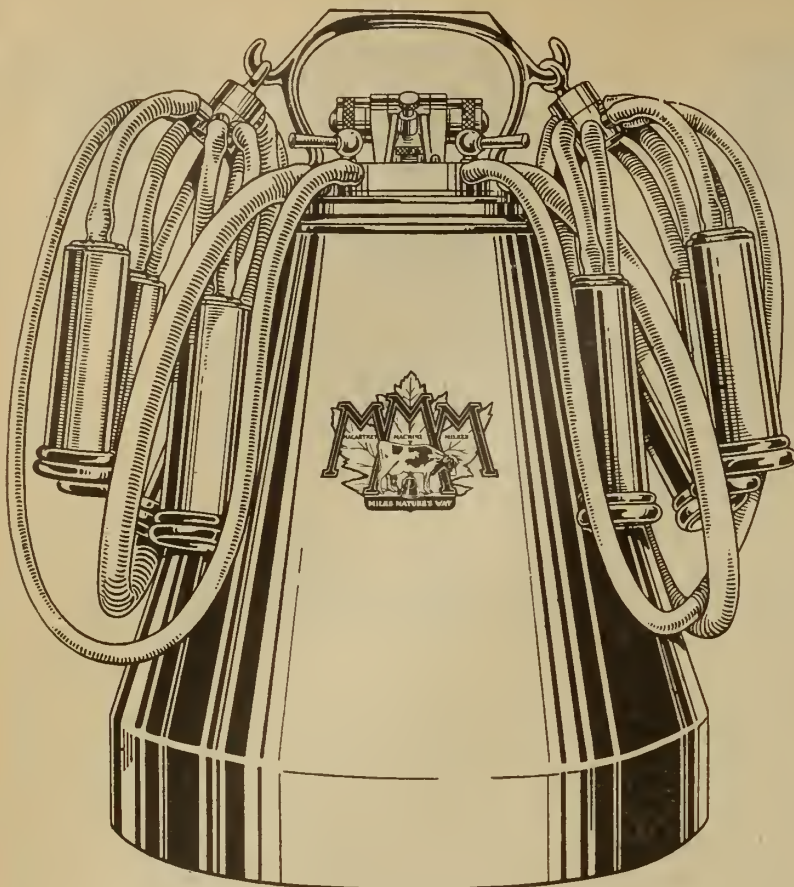

THE COW'S ADOPTED CHILD

## Will You Represent This Milker in Your Exclusive Territory?

To the live dealer, in a position to properly represent it, the **MACARTNEY MACHINE MILKER** will bring both prestige and profit.

Because the Macartney Machine Milker—100% perfect, efficient and durable—offers the man with cows the easiest and most practical solution of the prevailing labor problem.

This truth is being tellingly presented by means of a big advertising campaign in Canada's leading farm and dairy journals. It is creating the buying impulse in the minds of the farmers and dairymen right in **your** locality—and some one live dealer there is going to cash in upon it.

Will you be that dealer? **Now** is the time to decide. Quick action is advisable as territories are being rapidly taken up.

Write to-day for our agency proposition. Ask any questions you wish. Only—don't let this opportunity pass without at least investigating.

The  
**Macartney Milking Machine  
Co., Limited**

Ottawa

Canada

## Dairy and Household Supplies

### HOW TO SELL ELECTRIC WASHERS

**SOME** valuable points on selling power washing machines are given by Thomas F. Chantler, of the Society for Electrical Development, in Farm Machinery—Farm Power. He says in part:

Bear in mind, by the way, that it is not always the wealthy who are the best prospects. On the contrary, this class, being able to afford one or more servants, are often the poorest prospects. It is really the big middle class, the women who do their own housework, who will most appreciate the advantages of washing electrically. And in that connection it is interesting to note that only about 15 per cent. of the families in this country employ servants.

Go to the central station and find out where the largest number of new customers are coming from. Is there a new industrial development in your locality? Don't overlook the negro washwoman. It is surprising how many negroes are using electric appliances—washers in particular. Consider the real estate men. For instance, in one of the new additions in Toledo electric washers and ranges have been installed in each house by the builders. Flats and apartments, contrary to some opinion, offer excellent opportunity for washer sales. Classify the prospects, arranging them according to location and financial means and as far as possible group them. You will save your salesmen's time and your own money by concentrating on one district at a time. When you have made one sale in a block, work harder on the other prospects therein. Never let an inquiry get "cold." When you get a live lead, have it followed up promptly even if it is outside the district which you are working at that particular time.

Select the right kind of salesman. If you employ salesmen insist upon their representing you properly, creditably.

Sell the idea of washing electrically. The prospect buys the electric washer because of what it will do, not because of what it is. She is interested in learning wherein and why its use will save time, labor, money; she is interested in its construction only insofar as that contributes to those benefits. Picture the washer as making possible so and so much saving in time and labor, as saving wear and tear on the clothes and washing them better, as a solution of the "help" question, and so on. Describe those things so that the housewife can picture herself enjoying those benefits. It is for just that that she desires the washer, and it is for just that that she will buy it.

### CLEANER MILKING MACHINES

**DEALERS** have often to face the complaint by some of their customers that in order to keep the milking machine in first-class order too much time is required. This would seem to be one of the big complaints and one that practically amounts to the bug-bear of the milking machine business.

It is true that the milking machine must be kept scrupulously clean and in order to do this, constant attention is necessary, but the work if properly done should not consume much time. The new York Agricultural College has published a report giving several suggestions, which, if acted upon, will tend to reduce the time required for proper care to a minimum, and still provide for complete cleaning of the milking apparatus.

There is considerable waste effort in this work due to improper methods.

A common fault, says the report, has been found to be the manner of placing the rubber tubes and teat cups in the sterilizing solution. The container, usually a jar or crock, should be large enough—20 or 30 gallons for three sets of tubes—to immerse the tubes without trapping air in them. It is recommended that the tubes be let down into the solution slowly, holding them at one end and keeping them as straight as possible so that all air is excluded. When tubes are twisted or doubled up the solution will be prevented from entering. In cases where the screw cap at the end of the claw is without an air opening, this cap should be removed to allow the solution to drive out the air and reach all small passages and turns in the claw connections. This requires little labor and is effective in preventing the growth of bacteria in the milk passages.

### SELL CONCRETE FOR SILOS

**THE** dealer who sells the dairyman this milking machine, cream separator and electric plant should not overlook the concrete silo.

The implement dealer is the logical man to sell concrete. When he sells a pump, gasoline engine or electric plant he should also be in a position to supply the concrete necessary for the foundation. The concrete silo would come then as a matter of course.

There is a silo on practically every farm and the number of concrete silos built is growing rapidly. A concrete silo has many advantages and will in time replace those built of wood. They are air-tight, waterproof, fireproof, and vermin-proof—four very important points in silo construction.

In addition a concrete silo requires no repairs and does not rot. If you are thinking of taking on a new line do not overlook this one. It fits in admirably and will prove a very profitable and prospect getting proposition.

### COWS GREATLY INCREASE PRODUCTION

**IN** 1914 a number of patrons of the Tyron Creamery, Prince Edward Island (Canada), took up cow testing and have followed the work consistently right up to the present time. For the five years ending in 1919, every farmer has made a substantial increase in the average production of his herd.

In one or two herds the increase was as much as 74 per cent., which meant that these men received nearly twice as much milk from the same number of cows in 1919 as they received in 1915. The average increase was 33 per cent. One farmer had a net profit of \$78.57 per cow from his herd of 14 cows, after allowing on an average of \$100 per cow for feed.

If the production of every dairy cow in Canada could be increased as much as the production of these Prince Edward Island herds, it would mean an increased revenue of many millions of dollars from dairy products. This is just another instance of what can be accomplished by cow testing. It pays big returns.—Dairy Branch, Canadian Department of Agriculture.

### INCREASE SEPARATOR OUTPUT

**TO** increase the output of Primrose cream separators, the International Harvester Company is enlarging its Milwaukee plant. The addition will increase the present floor space by 14,000 sq. feet.



# DE LAVAL business founded on service

*The De Laval Cream Separator is built for service*



Its construction and workmanship are so excellent that it will continue to give good separator service for many years.

This is the main reason why 50,000 local agents the world over sell the De Laval. They can sell more machines with less worry and trouble-correcting afterwards, which so often eats up the profits of sales of inferior separators.

The De Laval Company is the oldest and largest separator concern in the world and its business has been built from the beginning on service —when a sale is made the De Laval Company considers that its obligation to the user has just started.

There is no better time than right now to send in an application for a De Laval contract

## SERVICE

**THE DE LAVAL CO., LIMITED**  
MONTREAL PETERBORO WINNIPEG EDMONTON VANCOUVER

50,000 Branches and Local Agencies the  
World Over



# CANADIAN Motor, Tractor and Implement Trade Journal BUYERS DIRECTORY

This directory will help you with your buying and your planning. The advertisers listed here are thoroughly reliable and leaders in their respective fields. They are looking for live, wide-awake representatives. Study their advertisements carefully because they contain valuable information which will dovetail with your plans. We are glad to go to the trouble of arranging this list—to make it easy for you to select new lines. If it so happens that what you want is not here, write us, and we will tell you where to get it.

## ACCESSORIES

Advance Machine & Welding Co., Montreal.  
Spaulding Chain Corp., Bloomfield, N.J.  
Champion Spark Plug Co., Windsor, Ont.  
Geo. W. Anstett, McGee, Sask.  
Guelph Spring & Axle Co., Guelph.  
Holton Hood Clip Co., Windsor, Ont.  
Lyons Ignition Co., New York City.  
Northern Electric Co., Ltd., Montreal.  
The Goodyear Tire & Rubber Co. of Canada, Ltd., Toronto.  
Apollo Plug Mfg. Co., Birmingham, Eng.  
R. F. Sedgeley, Inc., Philadelphia, Pa.  
Can. Fairbanks-Morse Co., Ltd., Montreal.  
McCord Mfg. Co., Walkerville, Ont.  
Kinzing Bruce Co., Niagara Falls, O.  
The Greb Co., Boston.  
Aikenhead Hardware Co., Toronto.  
Hyslop Bros., Toronto.  
The Specialties Co., Montreal.  
K. P. Products Co., 250 West 54th St., New York City.  
Perfex Radiator Co., Racine, Wis.  
Miracle Mfg. Co., Toledo, Ohio.  
Windsor Machine & Tool Works, Windsor, Ont.

## AUTOMOBILE CHAINS

Can. Fairbanks-Morse Co., Ltd., Montreal.

## BARN EQUIPMENT

Beatty Bros., Ltd., Fergus, Ont.

## BEAN MACHINERY

John Deere Mfg. Co., Welland, Ont.

## BEET MACHINERY

International Harvester Co., of Can., Ltd., Hamilton, Ont.  
John Deere Mfg. Co., Welland, Ont.

## BINDERS

The Frost & Wood Co., Ltd., Smiths Falls, Ont.  
International Harvester Co., of Can., Ltd., Hamilton, Ont.  
Massey-Harris Co., Toronto.

## BELTING

## BATTERIES

Can. Fairbanks-Morse Co., Ltd., Montreal.

## CARRIAGES

Cockshutt Plow Co., Brantford, Ont.

## CREAM SEPARATORS

De Laval Co., Ltd., Peterboro, Ont.  
International Harvester Co., of Can., Ltd., Hamilton, Ont.  
R. A. Lister Co. (Canada), Ltd., Toronto

## CEMENT MIXERS

Can. Fairbanks-Morse Co., Ltd., Montreal.

## CASTINGS

Joliette Steel Co., Joliette, P.Q.

## CHAINS

Spaulding Chain Corp., Bloomfield, N.J.

## CORN HARVESTERS

Cockshutt Plow Co., Brantford, Ont.  
International Harvester Co., of Can., Ltd., Hamilton, Ont.  
Massey-Harris Co., Toronto.

## CORN MACHINERY

International Harvester Co., of Can., Ltd., Hamilton, Ont.  
John Deere Mfg. Co., Welland, Ont.

## CULTIVATORS

Cockshutt Plow Co., Brantford, Ont.  
John Deere Mfg. Co., Welland, Ont.  
Massey-Harris Co., Toronto.  
The Frost & Wood Co., Ltd., Smiths Falls, Ont.  
International Harvester Co., of Can., Ltd., Hamilton, Ont.

## CUTTERS

Butterfield & Co., Inc., Rock Island, Q.

## DAIRY SUPPLIES

International Harvester Co., of Can., Ltd., Hamilton, Ont.  
R. A. Lister Co. (Canada), Ltd., Toronto  
DeLaval Dairy Supply Co., Peterboro.

## DIES

Butterfield & Co., Inc., Rock Island, Q.

## DISCS

Massey-Harris Co., Toronto.

## DITCHING MACHINES

Can. Fairbanks-Morse Co., Ltd., Montreal.

## DRILLS

Massey-Harris Co., Toronto.

## DRILLS, TWIST

Butterfield & Co., Inc., Rock Island, Q.

## DRILLS, GRAIN

Cockshutt Plow Co., Brantford, Ont.  
International Harvester Co., of Can., Ltd., Hamilton, Ont.  
John Deere Mfg. Co., Welland, Ont.  
The Frost & Wood Co., Ltd., Smiths Falls, Ont.

## ELECTRICAL EQUIPMENT

Westco Pump Ltd., Toronto.

## ENGINES

Can. Fairbanks-Morse Co., Ltd., Montreal.  
Gilson Mfg. Co., Ltd., Guelph, Ont.  
International Harvester Co., of Can., Ltd., Hamilton, Ont.  
John Deere Mfg. Co., Welland, Ont.  
The Frost & Wood Co., Ltd., Smiths Falls, Ont.  
Massey-Harris Co., Toronto.  
R. A. Lister Co. (Canada), Ltd., Toronto  
Renfrew Mch. Co., Renfrew, Ont.  
The Turner Mfg. Co., Port Washington, Wis.

## ENSILAGE CUTTERS

Can. Fairbanks-Morse Co., Ltd., Montreal.  
Gilson Mfg. Co., Guelph, Ont.  
International Harvester Co., of Can., Ltd., Hamilton, Ont.  
Massey-Harris Co., Toronto.

## FEEDERS

John Deere Mfg. Co., Welland, Ont.

## FARM MACHINERY

Can. Fairbanks-Morse Co., Ltd., Montreal.  
Cockshutt Plow Co., Brantford, Ont.  
John Deere Mfg. Co., Welland, Ont.  
International Harvester Co., of Can., Ltd., Hamilton, Ont.  
Massey-Harris Co., Toronto.  
The Frost & Wood Co., Ltd., Smiths Falls, Ont.  
R. A. Lister Co. (Canada), Ltd., Toronto  
Gilson Engine Co., Guelph, Ont.

## FEED CUTTERS

Can. Fairbanks-Morse Co., Ltd., Montreal.  
Massey-Harris Co., Toronto.  
Gilson Engine Co., Guelph, Ont.

## GREASE CUPS

The Specialties Co., Montreal.

## GRINDSTONES

S. Vessot & Co., Joliette, P.Q.

## GRINDERS

Can. Fairbanks-Morse Co., Ltd., Montreal.  
International Harvester Co., of Can., Ltd., Hamilton, Ont.  
Massey-Harris Co., Toronto.  
R. A. Lister Co. (Canada), Ltd., Toronto  
S. Vessot & Co., Joliette, P.Q.  
Gilson Engine Co., Guelph, Ont.

## HARROWS

Cockshutt Plow Co., Brantford, Ont.  
International Harvester Co., of Can., Ltd., Hamilton, Ont.  
John Deere Mfg. Co., Welland, Ont.  
Massey-Harris Co., Toronto.  
The Frost & Wood Co., Ltd., Smiths Falls, Ont.

## HAY LOADERS

International Harvester Co., of Can., Ltd., Hamilton, Ont.  
John Deere Mfg. Co., Welland, Ont.  
The Frost & Wood Co., Ltd., Smiths Falls, Ont.

## HARDWARE

Can. Fairbanks-Morse Co., Ltd., Montreal.  
Massey-Harris Co., Toronto.

## HAY RAKES

John Deere Mfg. Co., Welland, Ont.  
The Frost & Wood Co., Ltd., Smiths Falls, Ont.

## HAY CARRIERS

Beatty Bros., Ltd., Fergus, Ont.  
Massey-Harris Co., Toronto.

## HAY PRESSES

Birdsell Mfg. Co., Toronto.  
International Harvester Co., of Can., Ltd., Hamilton, Ont.

## HULLERS (Clover)

Birdsell Mfg. Co., Toronto.

## LIGHTNING SYSTEMS

Can. Fairbanks-Morse Co., Ltd., Montreal.

R. A. Lister Co. (Canada), Ltd., Toronto  
Northern Electric Co., Ltd., Montreal.  
Gilson Engine Co., Guelph, Ont.

## LIME AND FERTILIZER SOWERS

John Deere Mfg. Co., Welland, Ont.

## LUBRICANTS

Imperial Oil Co., Toronto.

## MACHINE TOOLS

Windsor Machine and Tool Works, Windsor, Ont.

## MANURE CARRIERS

Beatty Bros., Ltd., Fergus, Ont.

## MANURE SPREADERS

Cockshutt Plow Co., Brantford, Ont.  
International Harvester Co., of Can., Ltd., Hamilton, Ont.  
John Deere Mfg. Co., Welland, Ont.  
Massey-Harris Co., Toronto.  
The Frost & Wood Co., Ltd., Smiths Falls, Ont.  
Gilson Engine Co., Guelph, Ont.

## MARINE FITTINGS

Northern Electric Co., Ltd., Montreal.

## MOWERS

Cockshutt Plow Co., Brantford, Ont.  
International Harvester Co., of Can., Ltd., Hamilton, Ont.  
Massey-Harris Co., Toronto.  
The Frost & Wood Co., Ltd., Smiths Falls, Ont.

## MOTOR HORNS (Electric)

Apollo Mfg. Co., Birmingham, Eng.

## MILKING MACHINES

R. A. Lister Co. (Canada), Ltd., Toronto  
The Macartney Milking Machine Co., Ltd., Ottawa, Ont.

## MILLING CUTTERS

Butterfield & Co., Inc., Rock Island, Q.

## OILS

Imperial Oil Co., Toronto.

## PISTON RINGS

WedgeRite Piston Ring Co., Ltd., Montreal.

## PLOWS

Cockshutt Plow Co., Brantford, Ont.  
John Deere Mfg. Co., Welland, Ont.  
The Frost & Wood Co., Ltd., Smiths Falls, Ont.  
International Harvester Co., of Can., Ltd., Hamilton, Ont.  
Massey-Harris Co., Toronto.

## POLICE AND FIRE ALARM EQUIPMENT

Northern Electric Co., Ltd., Montreal.

## POWER AND LIGHT EQUIPMENT

Northern Electric Co., Ltd., Montreal.  
R. A. Lister Co. of Canada, Ltd., Toronto.

## POWER MACHINERY

Can. Fairbanks-Morse Co., Ltd., Montreal.

John Deere Mfg. Co., Welland, Ont.  
Massey-Harris Co., Toronto.

International Harvester Co., of Can., Ltd., Hamilton, Ont.

Gilson Engine Co., Guelph, Ont.  
Renfrew Mch. Co., Renfrew, Ont.

## POWER SWITCHBOARDS

Northern Electric Co., Ltd., Montreal.

## POTATO MACHINERY

John Deere Mfg. Co., Welland, Ont.  
Cockshutt Plow Co., Brantford, Ont.  
Can. Potato Mch. Co., Galt, Ont.

## PULVERIZERS

Cockshutt Plow Co., Brantford, Ont.  
International Harvester Co., of Can., Ltd., Hamilton, Ont.

## PULPERS

Cockshutt Plow Co., Brantford, Ont.

## RAKES

International Harvester Co., of Can., Ltd., Hamilton, Ont.  
The Frost & Wood Co., Ltd., Smiths Falls, Ont.

## REAPERS

International Harvester Co., of Can., Ltd., Hamilton, Ont.  
The Frost & Wood Co., Ltd., Smiths Falls, Ont.

## REAMERS

Butterfield & Co., Inc., Rock Island, Q.

## ROLLERS

Cockshutt Plow Co., Brantford, Ont.  
Massey-Harris Co., Toronto.  
Hyatt Roller Bearing Co., Chicago.

## ROLLER BEARINGS

Hyatt Roller Bearing Co., Chicago.

## SAW MILL OUTFITS

Massey-Harris Co., Toronto.

## SCUFFLERS

Cockshutt Plow Co., Brantford, Ont.  
International Harvester Co., of Can., Ltd., Hamilton, Ont.  
John Deere Mfg. Co., Welland, Ont.

## SEEDERS

Massey-Harris Co., Toronto.

## SCALES

Renfrew Mch. Co., Renfrew, Ont.  
Can. Fairbanks-Morse Co., Montreal.

## SCREW PLATES

Butterfield & Co., Inc., Rock Island, Q.

## STABLE EQUIPMENT

Beatty Bros., Ltd., Fergus, Ont.

## SILOS

Gilson Mfg. Co., Guelph, Ont.

## SLEIGHS

Cockshutt Plow Co., Brantford, Ont.  
International Harvester Co., of Can., Ltd., Hamilton, Ont.

## SILO FILLERS

Gilson Mfg. Co., Guelph, Ont.  
International Harvester Co., of Can., Ltd., Hamilton, Ont.

## SOCKET WRENCHES

R. F. Sedgley, Inc., Philadelphia, Pa.

## SPREADERS, MANURE

Cockshutt Plow Co., Brantford, Ont.  
John Deere Mfg. Co., Welland, Ont.  
International Harvester Co., of Can., Ltd., Hamilton, Ont.  
Massey-Harris Co., Toronto.  
Gilson Mfg. Co., Guelph, Ont.

## SPARK PLUGS

Machine & Stamping Co., Toronto.  
Champion Spark Plug Co., Windsor, O.  
Apollo Plug Mfg. Co., Birmingham, Eng.  
Lyons Ignition Co., New York.

## SPARK PLUG CLEANERS

Champion Spark Plug Co., Windsor, O.

## TELEPHONE APPARATUS

Northern Electric Co., Ltd., Montreal.

## TRACTORS

R. A. Lister Co. (Canada), Ltd., Toronto  
Essex Tractor Co., Essex, Ont.  
Gilson Mfg. Co., Guelph, Ont.  
International Harvester Co., of Can., Ltd., Hamilton, Ont.  
J. I. Case Threshing Machine Co., Inc., Racine, Wis.  
Massey-Harris Co., Toronto.  
Renfrew Mch. Co., Renfrew, Ont.  
The Turner Mfg. Co., Port Washington, Wis.

## TRACTOR PLOWS

Cockshutt Plow Co., Brantford, Ont.  
International Harvester Co., of Can., Ltd., Hamilton, Ont.  
John Deere Mfg. Co., Welland, Ont.  
Massey-Harris Co., Toronto.

## TIRES

## THRESHERS

Can. Fairbanks-Morse Co., Ltd., Montreal.  
International Harvester Co., of Can., Ltd., Hamilton, Ont.  
J. I. Case Threshing Machine Co., Inc., Racine, Wis.  
R. A. Lister Co. (Canada), Ltd., Toronto  
Gilson Mfg. Co., Guelph, Ont.

## THREAD CUTTING TAPS

Butterfield & Co., Inc., Rock Island, Q.

## TWIST DRILLS

Butterfield & Co., Inc., Rock Island, Q.

## TRUCKS

Motor Car Distributors Ltd., Montreal.  
Beaver Truck Builders, Ltd., Hamilton  
Eastern Canada Motor Truck Co., Ltd., Hull, P.Q.  
International Harvester Co., of Can., Ltd., Hamilton, Ont.

## WHEELBARROWS

Cockshutt Plow Co., Brantford, Ont.  
Massey-Harris Co., Toronto.

## WAGONS

Cockshutt Plow Co., Brantford, Ont.  
International Harvester Co., of Can., Ltd., Hamilton, Ont.  
Massey-Harris Co., Toronto.

## WATER BOWLS

Beatty Bros., Ltd., Fergus, Ont.

## WEEDERS

Cockshutt Plow Co., Brantford, Ont.

## WIRES AND CABLES

Northern Electric Co., Ltd., Montreal.



# Butterfield

## Drills, Taps, Dies, Reamers

and  
MILLING CUTTERS

Naturally, when you use Butterfield High Quality Tools, you look to them to do better work than ordinary tools could do.

—and you are not disappointed.

What surprises you is that even after they have given all the service one could reasonably expect they still continue to cut with their original accuracy.

—and that makes Butterfield Tools really cheaper than inferior instruments.



**Butterfield & Company**  
Rock Island P. Q.

Toronto Office: 220 King Street West





## Buying Two Barrels A Year

**T**HE average tractor owner uses two barrels of lubricating oil a year for plowing, discing, cultivating, harvesting, threshing and other belt jobs. The average automobile owner uses about one-third of a barrel. It will pay you to develop your tractor oil business with farmers.

The first essential is a good product. Sell Imperial Polarine Tractor Oils. There are three grades—Imperial Polarine Kerosene Tractor Oil, Imperial Polarine Kerosene Tractor Oil Extra Heavy, and Imperial Polarine Heavy.

From these three grades can be selected a suitable grade for any tractor. The Imperial Chart of Recommendations shows the grade recommended for each machine.

Imperial Polarine Tractor Lubricants save high fuel and repair bills, assure minimum wear on bearings and give thorough lubrication.

Build your lubricating business on the rock of permanence—on Imperial Lubricants.

Sold in four gallon, sealed lithographed cans, half-barrels and barrels.

**IMPERIAL OIL LIMITED**  
 Power ~ Heat ~ Light ~ Lubrication  
 Branches in all Cities



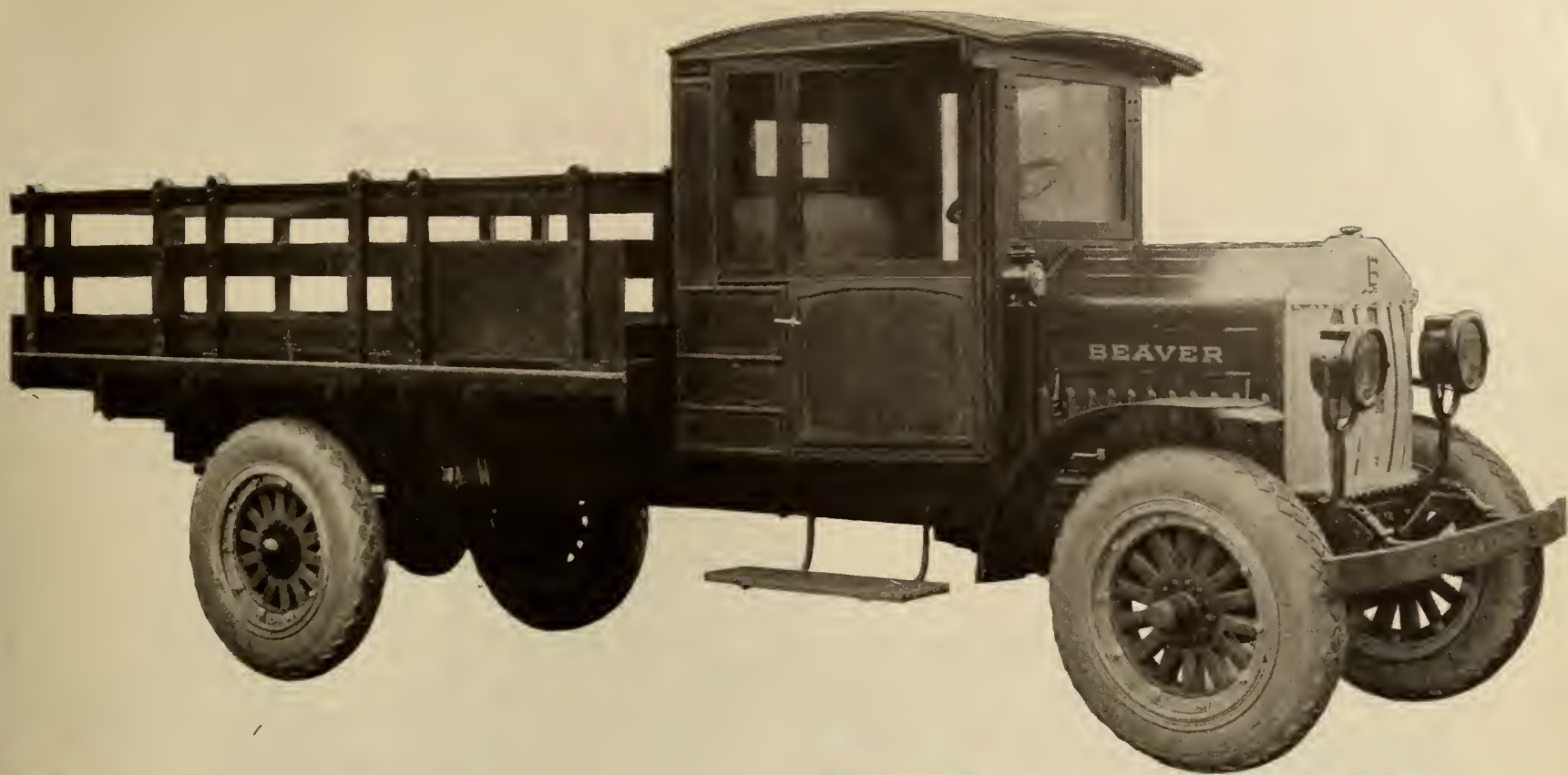

# Beaver Trucks

*"Built For Business"*

**Built in Canada's Largest  
Exclusive Truck Factory**

**UNQUESTIONABLY  
"CANADA'S LOWEST HAULING COST"**

Some open territory still available—Catalogues and further information furnished responsible dealers upon request.

**Beaver Truck Builders, Limited**  
HAMILTON, ONTARIO



# JUMBO

## HIGHWAY EXPRESS



Built in sizes  $1\frac{1}{2}$ , -2, -2 $\frac{1}{2}$ , -3, -3 $\frac{1}{2}$ , -4 tons

### Hauls Tonnage With Speed

The Jumbo Highway Express meets these requirements. It carries a full two ton load at 25 miles an hour *with safety* to the truck and load.

It has the power and strength for long, dependable service. It has the equipment for efficient, economical, comfortable operation.

This latest achievement is a big step forward in motor truck transportation, as a glance at the following brief specifications and partial list of equipment will show.

#### *Brief Specifications and Equipment*

Standard 56-inch tread, Buda Motor, Clark Internal Gear Drive Axle, Clark Steel Wheels with pneumatic tires, power tire pump, power take-off, electric lights, starter, horn, generator and storage battery. Steel cab with 3-man seat, heavy cushions, foredoors and disappearing curtains opening with doors, clear vision windshield, motometer, hub odometer, pigtail tow hooks, spring draw-bar and many other features. No extras to buy but the body.

*Sole Distributors in Canada*

**Motor Car Distributors, Limited**  
27 McGill College Avenue, Montreal, Que.



CANADIAN  
**MOTOR, TRACTOR AND IMPLEMENT**  
 TRADE JOURNAL

Published Monthly by THE MACLEAN PUBLISHING COMPANY, LIMITED, TORONTO

MONTREAL, Southam Bldg.

WINNIPEG, 1103 Union Trust Bldg.  
 NEW YORK, 1133 Broadway.

VANCOUVER, 314 Carter-Cotton Bldg., 198 Hastings St. W.  
 BOSTON, 734 Old South Bldg.

CHICAGO, 405-6 Transportation Bldg.

LONDON, ENG., 88 Fleet St., E.C. 4

VOL. II, No. 8

TORONTO, AUGUST, 1920

Subscription Price  
 \$2.00 Per Year



Highest quality long-fibre asbestos spun in the form of yarn around wire used as a base.



This shows a surface treatment discarded by us years ago



Here is partial impregnation also discarded by us

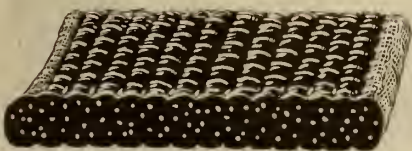

And this illustrates the COMPLETE and THOROUGH impregnation of Raybestos



A coil of Raybestos, edged with Silver, ready for installation

# Sturdy **WEAR** for Heavy Service

Raybestos Brake Lining WEARS like a strip of steel. It is designed and built to WEAR, so that the car owner receives additional service for less cost. It is this sturdy WEAR that gives security and control at all times, in any emergency. Here we show you why we are able to guarantee one year's WEAR. We use genuine long fibre asbestos. We impregnate every fibre of Raybestos by a special and secret chemical treatment which vastly increases its ability to WEAR.

Here is genuine asbestos. Here is genuine impregnation. Here is genuine WEAR. To get genuine Raybestos, "Look for the Silver Edge."

*Canadian Made for Canadian Trade*

# Raybestos

**BRAKE LINING**

THE CANADIAN RAYBESTOS COMPANY, Ltd.

PETERBOROUGH - CANADA



# Apollo

## BRASS SPARK PLUGS

—are sure and satisfactory sellers!

You're on a good thing when you handle APOLLO PLUGS—they represent the highest standard of British plug manufacture, are fully tested to ensure maximum efficiency and are guaranteed to give complete satisfaction.

With the APOLLO range of plugs you can promptly meet every plug request—there are models for every type of Car, Motor Truck and Tractor engine—and every plug carries a GOOD PROFIT for YOU.

Super Mica Plug, is specially designed for high-speed, high-compression engines. It is unaffected by excessive heat and of exceptional durability—a plug that gives a quick start and adds power to the Engine. Retail price ..... **\$1.25**

Porcelain Plug is specially designed for the FORD engine. It has Solid Brass body, 1/2-in. gas thread, is clean to handle, will not rust, fits the special Ford spanner, is insulated with finest porcelain and is detachable for cleansing. Retail at ..... **90c**

Get on to the APOLLO PLUG proposition and you'll do big business in selling plugs. We can give prompt shipment of all models and supply you with posters, showcards and advertising literature. Write us for trade terms and full particulars of our models.

### APOLLO PLUG MFG. CO.

Canadian Head Office:  
135 King St. West, Toronto. Factory: Birmingham, Eng.

Plugs for all engines

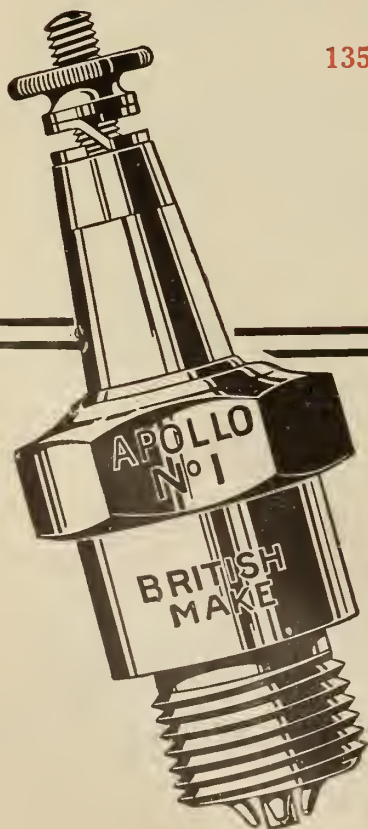

APOLLO No. 1. Super Mica Plug

APOLLO Special



Overtime Tractor Plug



APOLLO L.C.B. Special FORD Plug



# Announcement to LISTER AGENTS:

In connection with our exhibit at the

## Canadian National Exhibition

Toronto, August 28th to Sept. 11th

Here is one of the most important announcements we have made for many a day. Taking advantage of the immense opportunities for meeting customers at the Big Fair, we are making a

## *Special Offer*

*TO OUR CUSTOMERS*

Melotte Cream  
Separator

Lister Milking  
Machine

Lister Premier  
Cream  
Separator

Lister Farm  
Engine

Avery Tractor

Lister Silo

Ensilage Cut-  
ters, etc.

To every man or woman who makes, at our exhibit, a cash purchase of One Hundred Dollars (\$100) or more, we will make an allowance equal to his or her railroad fare both ways to and from any point in Old Ontario.

### How it benefits the agent

Every Lister agent who sends a customer to our exhibit will receive credit for the purchase at the exhibit, whether or not the agent makes the sale.

*Send your prospective customers to  
our exhibit.*

Do not fail to send around the good word to all your possible customers right away. Tell them about this splendid opportunity to visit the Canadian National Exhibition at our expense for railroad fare. It is your opportunity—get busy!

### Here is the OFFER

as explained  
in farm  
papers

To everyone who makes a purchase of \$100 or over at our exhibit, we will make an allowance from the regular price of any Lister machine, a sum equal to the amount of his railroad fare (only) to and from his home station. This great offer applies to any point in "old" Ontario, and to cash sales only. It does not include Pullman car or similar extra charges.

**R. A. LISTER & COMPANY (CANADA) LIMITED**

58-60 Stewart Street, Toronto



# *The Wonderful Gilson*

MADE IN CANADA



## IT STANDS SUPREME

### REASONS WHY:—

- 1—Your Customers demand the Gilson—Easy Sales—Big Commissions.
- 2—It has the largest sale of any Silo Filler under the British Flag.
- 3—Its wonderful performance brings repeat orders.
- 4—It is the lightest running blower cutter made.
- 5—Our entire organization is behind you.

## *Frankly Now, Doesn't It Look Good?*

You cannot afford to let this proposition go.

Don't put it off—write for our special agent's proposition at once.

Tear off, fill in and return the corner of this page. If you don't someone else will.

## IT MEANS DOLLARS TO YOU!

### Gilson Mfg. Co.

LIMITED

Factory and Head Office:

10118 York Street  
GUELPH, ONT.

Branch and Warehouse:

10128 Elgin Ave.  
WINNIPEG, MAN.

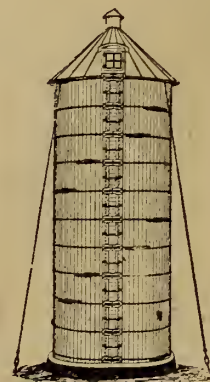

### The Hylo Silo

No farm is complete without the famous Hylo.

**BIG PROFIT—  
EASY SALES**

*Something worth adding to your lines.*

Without any obligation on my part you may send me your agent's proposition on:—  
(Put an X opposite the product that interests you)

Silo  
 Silo Filler  
 Engine  
 Thresher  
 Manure Spreader  
 Tractor

FILL IN AND RETURN AT ONCE  
Tear Off Here

Name .....  
Post Office .....  
R.R. No. .... Prov. ....  
Remarks .....



JOHN DEERE  
Low-Down Manure Spreader

JOHN DEERE  
Van Brunt Grain Drills

VAN BRUNT  
Lime and Fertilizer Sower  
Hoover Potato Diggers  
Hoover Potato Planters  
Hoover Potato Cutters

RELIANCE  
Field Sprayers

JOHN DEERE  
Beet Lifters

JOHN DEERE  
Beet Cultivators

JOHN DEERE-DAIN  
Rake Bar Hay Loader

JOHN DEERE-DAIN  
Side Delivery Rake

JOHN DEERE  
No. 999 Corn Planter

JOHN DEERE  
"JB" Corn Cultivator

JOHN DEERE  
One-Horse Cultivators

JOHN DEERE  
Spring Tooth Lever Harrows

JOHN DEERE  
Stiff Tooth Cultivators  
Grape and Berry Hoes

"WATERLOO BOY"  
Kerosene Engines

JOHN DEERE  
Tractor Plows  
Walking Plows  
Riding Plows  
One-way Plows

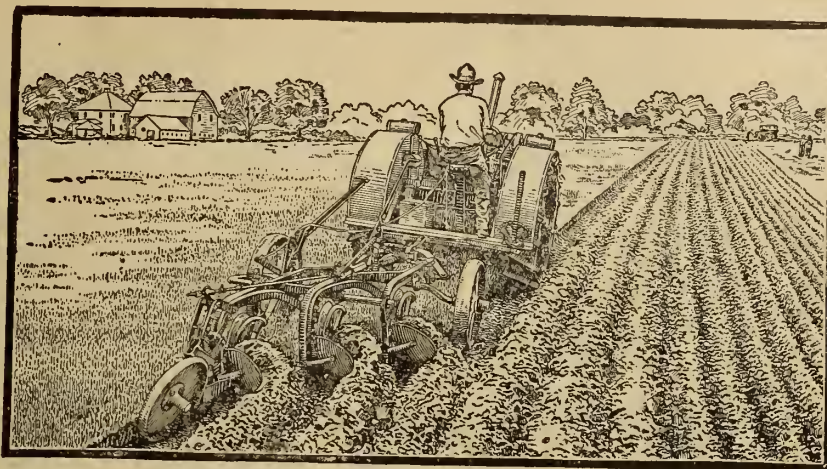

YOU are cordially invited to inspect the  
JOHN DEERE line of Farm Implements  
which will be shown and demonstrated at the

## Canadian National Exhibition Toronto

Your particular attention is directed to the  
JOHN DEERE line of Plows, which includes  
Tractor, Riding and Walking Plows, designed  
especially to meet Ontario soil conditions.

The Salesmanager and other Sales Repre-  
sentatives will be there to give you every  
attention and demonstrate the outstanding  
features of JOHN DEERE Implements.

The  
John Deere Manufacturing  
Co., Limited

WELLAND



ONTARIO



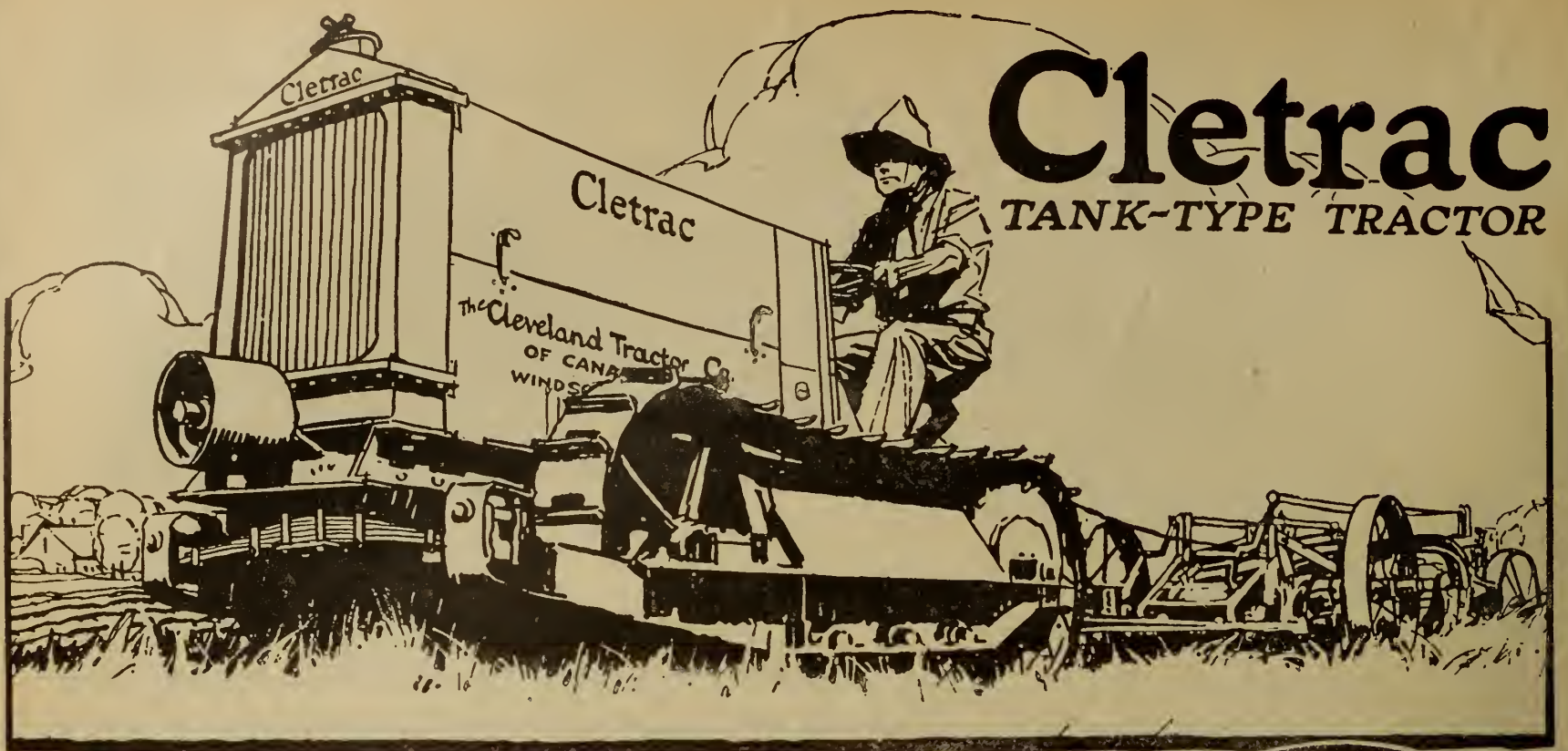

## Be Ready For Fall Orders

*More kinds  
of Work  
More days in  
the year*

This year the demand for Cletracs has been greater than we could meet. Our enlarged factory going full blast is speeding up production. The good work will be kept up and we believe we can take care of all orders. If any dealer loses out he will be the one who orders late. First come, first served. Send your orders in early.

Cletrac's many distinctive features have made it the choice of Canada's foremost dealers. Travels on its own self-laid tracks. Glides over the soil

without packing. Runs on coal oil, (kerosene), or gasoline. Goes everywhere. Does every job of hauling and belt work. Cletrac is needed on almost every Canadian farm.

Cletrac has back of it the largest tank-type tractor manufacturing concern in the world. Cletrac pays you well. It is a speedy seller. Satisfied owners are boosting Cletrac and Cletrac sales everywhere.

We have a very profitable dealer proposition for you. It will pay you to get in on Cletrac now. Get Cletrac literature. Get a grip on Cletrac facts. A mighty fine business is yours for the taking.

*And don't delay in getting in those orders.*

**The Cleveland Tractor Company  
of Canada Limited**

HEAD OFFICE:  
**WINDSOR, ONT.**

WESTERN SALES OFFICE:  
**REGINA, SASK.**



# HYATT

## ROLLER BEARINGS

### In these Plows

Avery Co.  
B. F. Avery  
Blount  
Grand Detour  
Vulcan

After long field tests, manufacturers of these plows have adopted Hyatt Roller Bearings as standard equipment in coulters.

Experience has shown that plows, as well as other implements, must be built as well as the tractor—must be able to work hour after hour and day after day, giving constantly dependable service.

Hyatt Bearings keep plow coulters running straight and true and need oil but once a season. They add to the life of a plow and are designed, built and installed for *permanent* service, never requiring adjustment.

This is typical of the advantages that Hyatt Bearings provide in other farm machinery, such as tractors, threshers, binders, wind mills, etc.

HYATT ROLLER BEARING COMPANY  
Tractor Bearings Division, Chicago

Motor Bearings Division, Detroit

Industrial Bearings Div., New York City

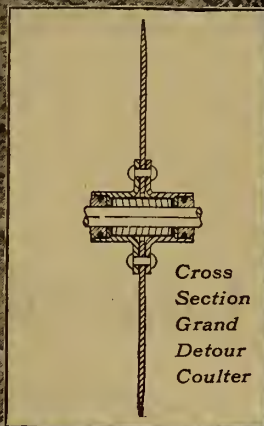



# \$5,000.00 in Prizes

—will be paid to the Fairbanks-Morse "Z" Engine and "F" Lighting Plant dealers throughout the Dominion, making the highest record in relation to the number of farms of his territory.

**for the sale of  
Fairbanks-Morse  
1½, 3 and 6 H. P. "Z" Engines  
and 40-Light Plants.**

Three dealers in each of the seven selling zones will be winners of prizes in this contest, and dealers all over Canada will be eligible to

## Grand Prize of \$1,000.00

which consists of \$750.00 plus the zone first prize of \$250.00; second and third zone prizes are \$100.00 and \$50.00 respectively.

Good territory is still open, but only first-class dealers need apply. Look over your district. Check up the prospects and write our nearest branch for full particulars. It means generous profits to you and a chance to win \$1,000.00.

**Contest open to Nov. 30th, 1920  
Prizes awarded Dec. 24th, 1920**

**An unusual opportunity for selling is open  
to live dealers.**

**Write to-day for details**

**The Canadian Fairbanks-Morse Co., Limited**

Halifax      St. John      Quebec      Montreal      Ottawa      Toronto      Hamilton  
St. Catharines      Windsor      Winnipeg      Saskatoon      Calgary      Vancouver      Victoria





# CANADIAN MOTOR, TRACTOR AND IMPLEMENT TRADE JOURNAL

Volume 2

TORONTO, AUGUST 5, 1920

Number 8

## Make Your Windows Pay Their Way

**W**HAT would you give to have new customers brought into your garage or salesroom with the definitely established idea that you are running an up-to-date establishment, that you are trustworthy and reliable? What do you do to disillusion the average run of motorist who may have the impression that your automotive department is little more than a junk shop? What do you think of a man who throws away one of his best means of making sales?

It is a trade axiom that no method of getting sales and attracting business is to be neglected. Yet the average run of accessory dealer neglects his windows. The automobile dealer and garage owner does not conduct a junk shop. A great many automobile dealers or garage owners' windows suggest that they do run a junk shop. Disillusion your customers and prospective customers by dressing up your windows. Many windows display chiefly dust and dirt. So infrequently is the window changed that it generally carries only a few pieces of unseasonable or obsolete equipment. The dealer whose window is so neglected has overlooked a means of building up his business.

When a customer comes to your shop, the first thing he sees is the window. If it is clean, if it is attractively and interestingly arranged, he enters your shop with the impression that he is entering the establishment of a wide-awake, capable and trustworthy dealer. He enters with an introduction which inspires confidence and which makes him an easy man to sell. First impressions are the most important in business. Confidence means renewed sales.

A window display should be changed frequently, so that interest in the window may not lag. It should be used to show attractive accessories, standard repair parts and the seasonable goods, and should keep abreast of the times and of trade developments. The display should be a "live" one, so that new customers will be brought in. I know of one window which carries in big display letters the well-known "Ten little niggers—" and below, "Ten great Accessories." Down in the window itself are ten painted wooden niggers, each holding out an accessory. It usually brings a customer in laughing and in just the frame of mind to buy.

**S**OME dealers believe that they are too busy to bother about changing their window displays, and that a showing in a window seldom brings new business. Dealers who work on this theory are taking a big chance that business will sooner or later ease up sufficiently to give them more than enough time to look after their windows. Some dealers have windows so dirty that one can scarcely look through them. Others have the glass so littered with signs and posters that nothing of the actual display is visible. This might be all right for a printing shop.

The window is a medium of free advertising, and is even more important than newspaper space, for which you are required to pay long prices. Many

By F. H. SWEET

dealers appear to believe that sales of automotive equipment come to them without their influence doing anything to impress the sales. They think the customer purchases only what he has made up his mind to buy. This is not so. The customer may know that he needs a new set of tires; but it is probable that he also requires a new lamp or a set of chains, and if his attention is called to these articles he will probably buy them. The window display should be an important factor in bringing equipment to the attention of the customer. Skilful use of windows calls for the display of goods which are at once seasonable and not over-assertive, that is to say, the dealer should endeavor to display goods which are likely to be in demand if the customer's attention is drawn to them, but which otherwise would not be asked for.

**W**INDOW displays should be attractive. They should be so arranged as to arrest attention at first glance. This may generally be achieved by using helps which are provided by many jobbers and manufacturers, such as attractive and interesting cards, demonstrating mechanisms, etc. A window should not be overcrowded. The average passer-by will give only a certain amount of attention to a window, and the greater the number of articles displayed the less interest he takes in any individual article. Strive for the happy medium whereat your window does not look crowded and does not look bare.

If you have decided to feature some trademark

article, get up your displays in conjunction with the national campaigns of the makers. Use the same arguments in your showing that the manufacturer does in his magazine or newspaper advertising. Make one help out the other. Use the window to tell your customer that you handle the product which has already been called to his attention by the national advertising campaign.

If you do repair work and have a service station, use your window to tell the inhabitants of your city or town about it. One of the most attractive displays possible is that in which some actual repair operation is performed in full view of all who may be interested. If your windows are sufficiently large, move some of your repair machinery into the window some day, and have one of your workmen carry on in the window, mending tires, tubes or parts of automobiles. You will be astonished when you see how the crowd collects.

Remember that you must pay rent for the space taken up by your windows. Therefore your windows should be yielding an income to you. They may be made to do this if you use them properly.

### I.H.C. Truck Programme

**T**HE International Harvester Company will add a new truck to its lines, known as the Model S Speed Truck, and the works at Springfield, Ohio, will be turned over to the exclusive production of this new model. It is estimated that the development of this new model will double the Company's production as soon as capacity can be reached. The

Model S International will be a 1,500 pound capacity truck, 115 inch wheel base, equipped with 34x5 pneumatic truck cord tires and electric lights and starter. The list price of the chassis will be \$1,500 f. o. b. the factory. The model will be assembled from approved standard units and will have an average speed of from twenty-five to thirty miles an hour.

Springfield works is a large plant covering seventy acres of ground, surrounded by green fields and wooded lands in the suburbs of Springfield, Ohio. It consists of long, roomy buildings, some of them four stories high, favorably arranged for modern, progressive assembly. The work shop for building bodies is an immense structure four storeys high and 403 feet long. Plans for the factory as developed for its new use contemplate fourteen units, consisting of twenty-one main buildings and ten minor structures. The plant will be under the works management of Cyrus McCormick, Jr., who has had charge of International Motor Truck production since April, 1919, and who is an enthusiastic and energetic believer in the present and future of the motor truck, and his command of this plant assures the full measure of his personal attention and supervision.



An artistic summer window background which can be painted by a good sign painter at moderate cost.

—Automobile Dealer and Repairer



# Good Roads, Automobiles and Implements

Anderson-Langstaff Garage, Kemptville, Ont., is Built for Service;  
Customers Visited Every Month

TWO men were one day discussing a subject, which, to the observer, would appear a very important matter indeed. The elder man—who was obviously a farmer—seemed to be “all het up” about something, judging by his manner in addressing the younger man in quick staccato tones, of nervously clasping and unclasping his hands behind his back and walking to and fro before his companion with rapid jerky steps. Every now and then when on his outward trip he would cast a look over his shoulder at the young man, which plainly said, “Gosh blink it, you’ve got all your nerve with you!”

The young man was an automobile salesman and was endeavoring to close a sale for an automobile. His excited companion was, as we hinted, a farmer and the scene was in front of the farmer’s house situated in Eastern Ontario.

If an observer had been close he would have heard a conversation something like this:

“Say, young man, do you mean to tell me that that car has gone up *that* much in price since last year? What—do you think we farmers are, millionaires? No, no, d— it, it’s too much! I can’t raise the price. Besides I can get along without a car. Come back another day when you have a better price, then—maybe—”

THE salesman pointed out that far from coming back in a while with a better price everything pointed to a decided rise. He emphasized the fact that the farmer’s family had now grown up and in order to keep his boys and girls beside him the farmer would require to supply them with the comforts and conveniences of modern days. The distance from the farm to the town was dwelt on and how necessary it was for him to have a speedy and comfortable means of communication. The amount and quality of service the salesman was prepared to give was also argued.

“Why!” said the salesman, “We guarantee to visit our customers every month; we will stay with you until you can run your car; our garage is in a position to give the fullest service, from free air to the most serious repair, including all phases of battery repairs and charging and vulcanizing.”

The farmer was a hard man to sell but the salesman “stayed with it” arguing, explaining and expostulating until he got a reluctant: “Aw, well, I’ll see what the wife and girls say.”

Needless to say the sale was made—which, by the way, was for a McLaughlin car—and the car was delivered on receipt of a deposit for part payment with the promise of the remainder in three months. In six weeks time the farmer paid the balance and expressed his satisfaction of the service rendered him and his pleasure in his purchase.

WE have taken the trouble in writing this rather lengthy introduction to point out the value of service, perseverance and tact, and knowledge on the salesman’s part of his customer’s conditions, nature and needs.

The young salesman was G. S. Anderson, manager of The Anderson & Langstaff garage of Kemptville, Ontario. He is a young man full of pep and good salesmanship. His motto is “Give the service; show what your goods are worth; then stay with a customer till he buys, or ‘bust’.” But, as Mr. Anderson would hasten to add, there is no occasion to bust if a man has the right goods and knows their worth.

The Anderson & Langstaff garage came into being in 1915. It is the latest and perhaps the liveliest

limb of a prosperous and well-organized company. As the Anderson & Langstaff Company operate a large departmental store in Kemptville it would seem at the outset that a garage is as much out of place as a third eyebrow on a fair lady’s face or as a certain odoriferous animal at a garden party. But, as a matter of fact, it is really a very logical development.

W. H. ANDERSON, the father of our salesman and the founder of the Anderson & Langstaff Co., was responsible for the garage. In order to explain the situation we must give a little history.

Mr. Anderson, senior, came to Kemptville as a



Anderson-Langstaff Garage, showing line up of cars and implements.

boy of 14 years, with practically no schooling. He picked up his education here, there, and everywhere. His first job was working in a store owned by one Andrew Blackburn. He showed considerable ability and saved his money so that in the course of some years he was able to buy out his employer and established himself as a proprietor. Later he took Mr. Langstaff in as a partner and after years of rapid development a joint stock company was formed under the present name of The Anderson & Langstaff Company, Ltd. The business was the usual departmental store, selling everything from pins to farm implements.

Mr. Anderson early evinced much interest in the development of good roads which ultimately led to the formation and operation by the same company of the Dominion Concrete Co., Limited. The building of a specimen mile of macadam road near Kemptville in 1900 gave W. H. Anderson his inspiration which brought the Dominion Concrete Co. into existence and ultimately the garage.

The machinery for this work, with operators, was furnished free by the Sawyer-Massey Co. in order to introduce their road making machinery to the district. The town of Kemptville and adjacent townships financed the work.

PART of the machinery consisted of forms for making culvert pipe. This pipe was made by the operators in the yard at the rear of the Anderson & Langstaff store. The pipe is still doing service in the roadway and the forms were sold to Anderson & Langstaff who commenced to manufacture this line of goods, at first to a local market which had to be created, and finally as the business grew, to shipping as far East as Halifax and West as Winnipeg to the extent of three and four hundred carloads per year—except during the war years.

The company also manufactures cement blocks for building purposes. They provided the blocks for the erection of the Kemptville post office which is an ornament as well as a utility. Contract work for the making of good roads, pavement, sidewalks and bridges became part of the company’s business. A stretch of concrete pavement on the main street of Kemptville was put down by the company in 1913 and is in perfect condition to-day without a dollar having been spent on it in the meantime.

This roadway is a part of the good road system of the counties of Leeds and Grenville. W. H. Anderson was one of the moving spirits in this venture to supply the surrounding townships with solid road beds and he kept at the work enthusiastically till his death in 1918.

IN 1913, to meet a demand the company, at Mr. Anderson’s suggestion, took on an agency for a certain car. This was the first agency of its kind in the district. The agency proved so successful and the demand for service grew so rapidly that, in 1915, they decided to build a garage.

The garage was put in charge of G. S. Anderson, son of the founder of the company, who has built up a very lively and up-to-date business. It is, of course, built of concrete blocks, 32x50 feet and two storeys high. The equipment is up-to-date and is provided for every branch of repair service. In the machinery department there is a lathe, drill press, battery-charging outfit, etc., etc. The battery outfit is a Stahl Rectifier capable of charging 12 batteries at a time.

Every phase of battery repair is provided and there are storing racks where upwards of 100 batteries can be stored.

A new building at the rear of the garage, 90x20 feet, has been erected for storing surplus cars. It is the company’s intention to extend considerably their present premises to meet the growing demand for service.

Besides automobiles, they handle tractors, trucks, and all kinds of farm implements and buggies.

“OUR business,” said G. S. Anderson, “has been built on service. We reckon that satisfied customers make our best advertisement, and we accomplish this by a policy of seeing every customer once a month. We keep in close touch all the time and by doing so make many a sale which we, perhaps, otherwise would not.”

“Our policy of selling is practically for cash. In some cases where we are sure of our man we allow some time but every dollar is paid in within the year of the sale. There is no price cutting and we treat everybody alike.”

“We have a good agricultural district and enjoy a large volume of implement sales. We have a complete implement and power farming list and also do a big business in cutters and buggies. In course of time we expect to sell a large number of trucks. The good roads we are having built all around us will help materially to increase our truck and automobile sales.”

“In the matter of trading in second-hand implements, we long ago decided to shy clear of such a dangerous business. It doesn’t pay and anything that doesn’t measure up should be left severely alone.”

“We advertise in the press continuously and follow up prospects closely. As I am the principal salesman I am out in the country most of the time—believing that an incessant and intensive canvas is



the best method to sell automobiles, trucks, tractors or implements. It brings results and keeps me in touch with my prospects, so that I get to know them and understand the conditions under which they work and am therefore in a position to determine their needs.

"OF course we make some sales without apparent effort on our part. For instance, not long ago a school teacher came in and asked the price of a certain car. We quoted the regular price and after a few questions about the car he departed. That same afternoon he 'phoned and instructed us to send along the car he saw in the morning. That was a very easy sale but they are not all made so easily.

"One day I went to a village about eight miles from Kemptville to talk to an old retired farmer and try to sell him a car. He was about 65 years of age and from information in my possession much interested in a car. I took a new car out with me for demonstration. The old farmer had a reputation for being very careful, but he had a companion with him who was even tighter and known as a notorious 'tight wad.'

"I got the two men in the car, my prospect beside me in front and the village 'tight wad' in the rear seat. After riding around a bit I persuaded my prospect to take the wheel which he did rather nervously. But, as he posed before his companion, and liked to be thought of as being 'ready for anything that came along,' he determined to make a good showing. We got on to a road where there was a deep ditch at one side and, of course he—like the bird and the snake—got fascinated by the ditch and went so close we were in danger of having our necks broken. 'Tight Wad' in the rear yelled out 'My God, William, where are you going,' and William replied 'By heck, I'm just trying to see what she can do.' However, when I took the wheel I noticed he didn't put up much of a kick.

"WHEN we returned to William's home all the village turned out and commenced to give advice, the burden of which was that William should not buy the car. In this they were backed up by Tight Wad. I saw if I meant to make a sale that I must get my prospect by himself, so I hurried him into the house, and got him seated on the back veranda. It was a big pull getting him to sign the contract, not because he didn't want the car, but because he insisted on knowing everything about it—how it was lubricated and if he should do it often; where the gasoline was put and how much it took to run a mile. I verily believed he asked me everything that could be asked and then some. However, after the pen had exchanged hands about six times he finally wrote his signature. Now he is an enthusiastic motorist and takes great pleasure out of his car.

"Our greatest difficulty at present is to get goods. We can sell as much as we can get.

"If it were possible to express in one word the reason for the measure of success we have achieved I should have no hesitation in saying that that word is SERVICE."

The Anderson-Langstaff garage have agencies for McLaughlin, Ford, and Briscoe cars and Ford truck, together with all implements including tractors, buggies and cutters. They are out to sell satisfaction believing that that is the commodity to sell if their business is to be successful.

## Selling Motor Trucks on an Honest Basis

By G. R. DONALDSON

EVERY reader of M. T. I. is anxious to do his part to keep the sale of motor trucks in Canada going on the proper lines so that conditions will not develop where the banks may stop advancing money to truck dealers, simply because of improper merchandising methods that could easily bring the truck industry into disrepute.

With competition becoming more keen every day, there has lately developed among some truck dealers the habit of making exaggerated claims for the trucks they are selling. This practice, if continued, will certainly be dangerous to the whole industry.

A 32x3½ solid truck tire is designed to carry 1,300 lbs. The steel base and rubber compounds that go to make up the tire are balanced so that under a maximum load of 1,300 lbs. the tire will give resiliency and traction and have a long life. While it is true this tire will carry more than 1,300 lbs., is it good business to sell that tire, even under the pressure of strong competition, to a purchaser who will expect it to carry more than 1,300 lbs.? Would not it be better to be honest about it and say that to carry more than 1,300 lbs. he should have a 4 in. tire, which has a carrying capacity of 1,700 lbs.?

Exactly the same condition applies when truck dealers sell a 2-ton truck to a man on the understanding that the truck is so sturdily built that it will carry far more than 2 tons. It is hardly fair, under such conditions, to blame the truck operator for overloading and causing the premature breakdown of his truck. Every time this happens—and it happens only too often—the truck dealer has put a most serious handicap on the future of motor freight transportation in the Dominion.

TRUCK manufacturers realize these conditions, but it is rather difficult to cope with them. One manufacturer has considered it so serious, however, as to withdraw the tonnage rating customarily used, identifying the various sizes of trucks by a model number, and then selecting a type for each individual requirement.

A truck on the streets of a city will most of the time be on smooth pavements and is undoubtedly able to withstand the injurious effects of overloading to a degree. But put the same truck on the streets of a city with steep hills and rough roads, and overload-

ing of even a small amount would be indeed a serious consideration.

A truck moving only short distances over good roads could be operated at a reasonable cost with solid tire equipment. The same truck used in inter-city hauling, where the time element and bad roads are important considerations, would undoubtedly be more economically operated if pneumatic tires were used. The old saying that "You can't get something for nothing" holds true in the merchandising of trucks as in everything else. The buyer of a truck cannot expect to have a 3½-ton capacity truck when he is only spending enough money to buy a 2-ton truck, and he must expect to pay a reasonable price to secure a worth-while article in return.

IN designing a truck, or designing truck tires, there is an allowance made to take care of particularly severe usage under emergency conditions. The construction is such that the rated capacity can be carried under average normal conditions, but if the road conditions, as an example, are a little worse than the truck designer expected the truck to work on day after day, there is an extra strain. This is taken up by the emergency allowance built into the truck and the truck tires. It is pretty well known that dealers sometimes, under the stress of keen competition, make exaggerated claims and in some cases actually advise overloading by telling the truck purchaser that his truck is so well built that while it is rated at a certain tonnage capacity, it will carry 50% more with complete safety.

Tires make up one of the largest items of transportation expense, and while allowance is built into them to take care of particularly severe conditions, it is just as impossible to expect long mileage when the truck is overloaded as to expect good service from the truck constantly working under a strain.

To keep the merchandising of motor trucks on a solid financial foundation, it will be necessary for all truck dealers to recognize that there are physical limitations to every truck and every truck tire. Best results can only be obtained by co-operating with the manufacturer who is doing his best to produce an article of worth that will give satisfactory service in exchange for the money invested in it.



A section of the concrete roadway built by the Dominion Concrete Co. for the Town of Kemptville.



# CANADIAN MOTOR, TRACTOR AND IMPLEMENT TRADE JOURNAL

Published on the fifth of each month by

The MacLean Publishing Co., Limited  
TORONTO, MONTREAL, WINNIPEG

JOHN BAYNE MACLEAN, President.  
H. T. HUNTER, Vice-President.  
H. V. TYRRELL, General Manager.  
LONDON, ENG., THE MACLEAN COMPANY, OF GREAT BRITAIN, LTD., 88 FLEET STREET, E.C.  
BRANCH OFFICES: Montreal, Southam Building, 128 Bleury Street; Winnipeg, 1103 Union Trust Building; Vancouver, 314 Carter-Cotton Bldg., 198 Hastings St. W.; New York, Room 620, 1133 Broadway; Chicago, 405-6 Transportation Bldg.; Boston, 734 Old South Building.  
SUBSCRIPTION PRICE—\$2.00 A YEAR.  
OFFICE OF PUBLICATION—143-153 University Ave., Toronto.

Vol. TORONTO, AUGUST 5, 1920 No. 8

## Electric Railway vs. Motor Bus

ALL over the world to-day street car systems whether under private or public ownership, are facing financial losses. It is a difficult matter to put the finger on the particular reason or reasons, for these losses. Increased rates for service is undoubtedly one of the reasons, but it is not the whole reason by any means. Some companies are advocating increasing the rates, but the public is quite emphatic in its opinion that present rates are high enough. If the rates are raised there is every possibility that large numbers of people will walk more, especially those who take the cars over the short hauls, and as everybody knows the short haul is the cream of the business.

Discussing the problem, the Regina Leader says: "The truth of the matter seems to be that the day of the fixed electric tramway is past. The coming of the motor car in its tens of thousands, paved streets and good roads have sounded the doom of the fixed tramway; with its arbitrary routes, and expensive rail and overhead equipment and large central generating station. Today astute financiers do not look with favor upon the securities of electric tramway systems. They do not consider them a safe and profitable investment.

"Regina has such a system now, and must make the best of it, but our citizens would be shortsighted indeed if they did not look forward to the time in the not distant future when the whole system will have to be scrapped. The day is surely coming when it will be more economical to scrap the system than to maintain it. At the present time the system is not only losing money on the investment, but it has never provided one cent towards depreciation, a depreciation which will amount to 100 per cent. in, we believe, the not distant future, a truly serious condition to contemplate."

Premier Drury has insisted on an investigation of the Hydro Radial projects for Ontario. The Hydro power production is not questioned by the Drury Government, but they insist on a scrutiny of the radial policy before the province is committed to a highly expensive system.

There is a strong impression among thinking men that the motor bus and motor truck should have a fair trial to meet the world's transportation needs. The automobile and truck traffic is growing at a remarkable rate and the good roads policy of the various governments is increasing that traffic. As we have pointed out before, we are of the opinion that the truck and motor bus will more and more carry the world's merchandise and take care of the travelling needs of the public. If there is grave doubts in the minds of financiers and experts, concerning street railways NOW, what effect will the rapidly increasing automotive traffic have in the same minds in the very near future.

It may be that there is an economic use for the radial in the future, but it is as certain as night follows day that the motor truck and the motor bus will take an important part in the transportation future.

It is because we believe this that we have been for months urging our implement and auto dealers to get in on the truck business. The truck day is coming—if not now at our doors—and the dealer who gets in early will be the man who will benefit by the enormous sales predicted for the near future.

## The New Taxes Defined

THE Montreal Automobile Trade Association has issued a bulletin in which it discloses the reply of the Inland Revenue Department to questions relating to the application of the excise taxes on automobile products.

The questions of the Association and the answers of the Revenue department follow:

"Do we understand that the 15 per cent. or 20 per cent. excise tax is payable on the United States manufacturers' net price plus the 5 per cent. United States war tax, plus the Canadian 35 per cent. duty?" (in other words, the duty paid price.)

"The tax of 15 per cent. or 20 per cent., as the case may be, is collectible on the duty paid value."

"Do the words 'retailing for not more than \$3,000' mean that the United States manufacturers' list price, plus the Canadian 35 per cent. duty, shall not exceed \$3,000?"

"The words 'retailing for not more than \$3,000,' referred to in the resolution, means that the United States manufacturers' list price, plus the customs duty, shall not exceed \$3,000."

"Do we understand that the 1 per cent. and 2 per cent. sales tax collected at time of paying duty applies on the United States manufacturers' net price plus the United States war tax, plus the Canadian duty?" (in other words, the duty paid price.)

"As respects imported goods the tax of 1 per cent. and 2 per cent., respectively, is payable to customs upon the duty value at the time of importation."

"In addition to paying 1 per cent. or 2 per cent. sales tax on cars when imported, do we pay an additional 1 per cent. when sold:

- "a. To the ultimate consumer, or
- "b. When sold to a sub-dealer, who in turn sells to the ultimate consumer?"

"The tax of 2 per cent. is applicable only upon importation by a retailer or user, in which case no further sales tax is payable. If imported by a wholesaler, the tax of 1 per cent. is collectible and again applicable when sold by him."

"Do we pay 1 per cent. or 2 per cent. sales tax on

- "a. Repairs made to cars?
- "b. Parts used on such repairs (sales tax already having been paid when imported)?

"c. Accessories, tires, or repair parts, etc., bought by us from Canadian manufacturers or from importers and sold by us to

- "1. The ultimate consumer,
- "2. To sub-dealers or garages?"

"a. No excise tax is collectible as respects labor involved in making bona fide repairs;

"b. Assuming you are wholesalers, a tax of 1 per

cent. is collectible on parts sold for repairs to automobiles;

"c. When accessories, tires or repair parts, etc., are bought by you from Canadian manufacturers or from importers and sold to

- "1. The ultimate consumer or
- "2. Sub-dealers or garages, the sales tax of 1 per cent. is payable thereon."

## The Wrong Kind of Service

A MOTORIST dropped into our office one day recently and in the course of a discussion on batteries—this man was at one time a battery expert—related the following, which we pass on to our readers.

At the close of last season, when he was laying up his car for the winter months, one of the leading garage men in his town approached him about his batteries. This garage man claimed to do first class battery repairs and advised the motorist if he left his battery with him he would put it in first class repair and have it all ready for him when next season opened. The motorist gave him the battery and at the opening of the season called at the garage for it, only to be informed that it wasn't quite ready as one of the cells had a short circuit.

The motorist was naturally surprised and irritated and demanded to know why, if the battery had been properly repaired and in the garage all winter, it should now have a short circuit. The garage man had nothing to say except that "he didn't know; it was all right at one time."

After a delay of several days, the battery was sent to the motorist as being O. K. The motorist found it anything but O. K. and had to send it to the manufacturers to have it overhauled.

In spite of the fact that the motorist in the terms of the battery contract was entitled to free service—having purchased the battery from the garage man—he received a bill which under any circumstances would be considered high.

Now, honestly, what do you think of such service? Is it any wonder that this garage man is losing business? He deserves to lose it and lose it quick. We are glad to say, however, that such a case as the foregoing is exceptional, but it serves to emphasize the fact that only by giving real, honest service can the garage man hope to be successful.

## Carry Less Currency

"KEEP less currency in your pocket," was an appeal made by Richard S. Hawes of the American bankers' association to the delegates in attendance at the recent convention of credit men.

"The federal reserve system has given us machinery for the supplying of our legitimate requirements. But we now know that it is highly desirable that the issue of federal reserve notes should not go beyond the present point, in fact, that the volume should be reduced. And one way to reduce the volume is to quicken the circulation of this currency in the hands of the people and we can help assure this process by not carrying pocket money beyond reasonable needs.

"The hoarding of currency is to be especially condemned. The tendency to hoard among foreign-born workers whose earnings are today in excess of anything they have enjoyed before, is well known. They hoard because they do not understand or appreciate the safety of our savings institutions, and feel that the money coming into their hands and not spent for necessities must be kept in their pockets, or their stockings, or some other hiding place. Our efforts should be to establish their confidence in our various classes of savings institutions and get in circulation all this large amount of currency which they keep in hiding."

## The Anti-Glare Law

THE Ontario anti-glare law, which requires all Ontario motorists to have their car lamps equipped with an approved anti-glare device, came into effect on July 19, but it will be impossible to enforce it at present. Appliances are now being tested and the Deputy Minister of Highways, W. H. McLean, has stated that the department will publish in the near future a list of firms whose equipment for reducing glare and throwing the light down on the road had received approval. A reasonable time will be allowed motorists to comply with the law, after the list has been published.

THIS OR THIS

A WORD to the WISE is SUFFICIENT

To Which Class Do You Belong?  
—E. B. Dealers' Magazine.



# Machinery and the Farm Labor Problem

**I**N most sections of America the farm labor shortage bugaboo is at present kicking up a big rumpus. Farm laborers and the potential farmers of tomorrow—boys just ripening into manhood—are migrating to the cities in flocks and droves, seeking the not-so-elusive golden fleece of high wages and short working days. Many farmers are selling out their livestock and equipment and following suit.

In the States the epidemic is even worse than in Canada. It is estimated that within a year 24,000 farms have been abandoned in New York State, and 30,000 in the State of Michigan. If one were to trail the city-journeying farmers represented by this extensive exodus, many of them, no doubt, would be

By B. J. PAULSON

ing by the broadcasting method, he could plant approximately eight acres in a day, resulting, incidentally, in a deplorable waste of good seed, because of wind-blowing or bird banqueting. When harvest time came round he could cut half an acre a day with a sickle if he had a strong back, or if he had one of those highly developed harvesting tools of that day, the cradle-scythe, he could harvest upward of 2½ acres in a day by steady, unremitting swinging of the cumbersome implement. And after the harvest was garnered it was threshed out with a flail—at the

of ground can be plowed in the same length of time. Compare this to the two acres a day of the one-furrow plodder, who still is very much in evidence.

Today one man with a tractor and two 8-foot grain drills can plant 40 acres in a day and be assured of practically 100 per cent. germination of seed, as contrasted to the 8 acres a day and 50 per cent. germination of seed by the broadcasting method.

And when it comes to harvesting, the present-day farmer runs up an acreage of from 10 to 20 acres in a day, according to the size of binder he is using, which may include cutting, tying into sheaves and stooking, (the latest combination), all done in the same length of time that one man would require to cut merely 2½ acres by hand. In some of the western provinces modern harvesting goes even a step further for there the harvester-thresher cuts, threshes, cleans and sacks the grain as a one-unit operation, at the rate of from 15 to 125 acres in a day!

**A**ND so it goes. Where one man threshed seven bushels of wheat in a day with a flail one hundred years ago, one man and one or two helpers, with a small individual threshing outfit, can now thresh 50 bushels an hour, while a large thresher will handle wheat at the rate of from 220 to 375 bushels an hour. Where the farmer made one trip to town with a load of farm produce with a team and wagon—and still does, for that matter—the progressive agriculturist of today makes three or four trips with his motor truck, saving the difference in time for essential farm work. Where one man cut one acre of hay in a day with a scythe, he can, with a mower cut ten acres without difficulty and with a horse rake gathers twelve times as much hay in a given time as by hand. Where it took three men 25 minutes to throw on a load of hay by hand, one man can do the same work in fifteen minutes today. Such is the labor-saving value of modern farm implements.

And so today farming isn't so much a matter of men as of machines. With proper farming equipment 10 per cent. of the present population should be able to feed the other 90 per cent., which is an extreme reversal of the situation that existed a century ago. Wonderful progress has been made during the past decade in the development of farm machinery and still greater progress is due to transpire within the next few years. The present migration from the city to the farm will serve as a stimulus to this progress. And the retail implement dealer, together with the manufacturer, will reap the benefits incidental to the increased demand for farm equipment, brought about by the decreased labor supply.

The journeyings to the city of many farmers and farm labor is by no means the tragedy that

(Continued on page 24)



To-day the small thresher operates at the rate of 75 to 150 bushels of wheat an hour.

run to earth in the conveniently located, prospering automobile factories.

Many people have become panicky at this very concrete manifestation of rural unrest and in some cases the press and various civic organizations have instituted "back to the farm" movements in the large cities, in a vain attempt to stem the tide of farm labor, which is sweeping into the great industrial centers everywhere.

But isn't a great deal of this futile hullabaloo uncalled for? If we'd look at the situation with an analytical eye, perhaps it wouldn't seem quite as desperate and hopeless as it otherwise does. It may be that this cityward movement is all for the best and may prove the foundation for a greater and better agriculture. True many farmers are seriously handicapped by lack of labor during the present transitional period—but therein lies the great opportunity for the farm implement dealer. At no time has the implement dealer occupied so important a place in the economic and industrial scheme of things as at present—and the future holds even greater promise for him. This is so because modern farm equipment is the logical solution of the farm labor shortage, which affects the entire fabric of industry and existence.

**O**NE hundred years ago between 60 and 80 per cent. of the people in America lived on farms. This high percentage of farmers was necessary because of the small individual farm production possible by hand methods. The farmer raised but very little more than enough to feed himself and family. He made his own boots and shoes and his own clothing, and often manufactured his own farm equipment—or had it made in a backwoods blacksmith shop. He could not devote all of his time to the actual business of farming as does the farmer of today, for he was a jack-of-all-trades who had to provide, constructively, for the outer man as well as the inner man. And on top of this, his farm operating equipment was hopelessly inadequate to produce much more than enough food to supply his own needs. The surplus left over for city consumption was limited. What he lacked in equipment had to be made up for in man power.

With a one-horse walking plow of a century ago one man could plow, perhaps two acres a day. Seed-

rate of 7 bushels of wheat in a day, 18 bushels of oats, 15 bushels of barley or 20 bushels of buckwheat, according to Thomas' book on Farm Machinery. Or he could thresh it by treading out the grain with oxen at the rate of almost two bushels an hour and, of course, having the oxen tramp on the grain added greatly to the flavor of the flour, or meal, for which the farmer made no extra charge!

And in the matter of haying, a farmer did well to cut an acre a day with a scythe and raked the hay by hand at the same rate.

That was less than one hundred years ago. Consider the contrast of present-day methods:

Today one man with a 10-20 tractor and a three-furrow power-lift plow can turn from 7½ to 10 acres in a day, while with a large tractor 30 acres



The present-day farmer harvests his grain crop with a binder at the rate of from 10 to 20 acres a day.



# ROSENHEIM PAINTS HIS CAR

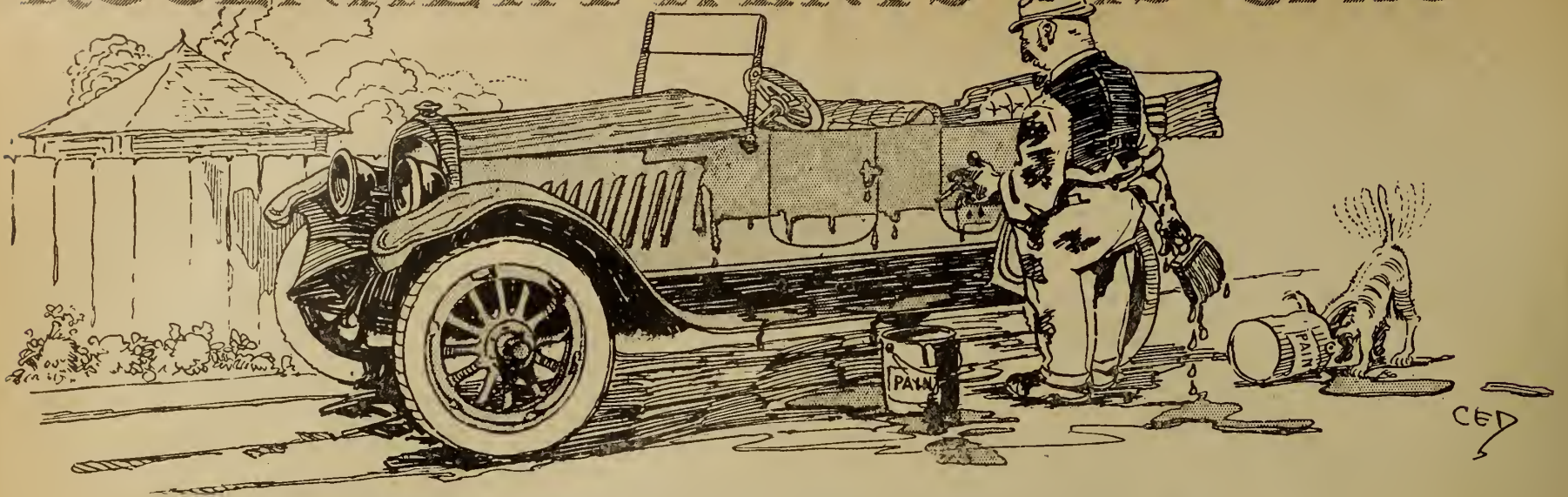

Pinched (With Permission) From "Timken Magazine." Sketches by CLYDE E. DARR.

"MAX, a disgrace it is the way our car looks, and I bet Mrs. Cohen she smiles sneeringly ever time she sees us ridin' in it," said Mrs. Rosenheim to her husband, Max Rosenheim, proprietor of the Scotch Woolen Mills Emporium, High Grade Men's and Boys' Clothing.

"And it is little I care for Mrs. Cohen. With such a face and disposishun what she has got she has mighty little amusement anyway, so she can laugh her dam head off for all I care. I'll admit without any argyment that the car looks rotten, but ever time I make up my mind on a nineteen twenty model, right away they boost the price another hundred or two. What with them fool overall clubs puttin' the clothing business on the bum, railroads a strikin' and taxes gettin' higher ever minnut, it looks like if war is hell, whadda ye call peace? Spose mebbe now all the clothing factories, dealers and tailors would resolve that the price of ottermobiles should be brought down to where the poor bizness man could afford as good a car as a bricklayer or a plumber, and should start a movement that everboddy should ride in a second-hand flivver, mebbe it would help some."

"Mebbe it would, Max, but if it should become fashionable to ride in them patched up cars, with ours lookin' the way it does, we would be leaders in society."



Never will I ride in it again, unless you paint it and fix it up anyway."

"Now, Rachel, that's an idee," said Max enthusiastically. "After all there ain't reely nothing the matter with that car, and I bet if it was painted and new curtains and fenders, it would look like a new

car. I just guess I go down to Aaron Finckheim and get him to give me a price on the job."

WHEN Max returned in the evening his early enthusiasm had vanished. "Yes, I see Aaron Finckheim, Isaac Grabenburg, Sol Meyers and Herman Goldstein. And such robbers they all are. One hundred and forty dollars is the lowest price I can get. You would think them fellers had nothin' in their employ but high grade portrait painters what worked on motor cars between sittins for millyunaires. I guess if that car is painted I paint it myself."

"Why, Max, you ain't no painter," said Rachel scornfully.

"No, and I ain't no barber, but I shave myself and cut Abie's hair, and I ain't no plumber, but didn't I set up the gas stove? It is just foolishness to think that no one but a painter can paint anything. Paint is all ready mixed, and you just buy a brush and spread it on even. Now all we got to decide is the color and right away I fix it up."

"Well," said Rachel, "I kinda like green with red wheels."

"Green paint is too expensive, I asked, and if you have a different color for the wheels you got to have another brush. Mayroon is a nice color, ain't it? Besides Isadore Frankel has a lot of it what he will sell reasonable."

"But, Max, Isadore Frankel sells paint for houses. Don't you have to get a higher grade for autermobiles?"

"Paint is paint, Rachel, and mayroon is mayroon whether it is on a house or a car, so I tell him I takes eight gallons at three dollars a gallon and he throws in a brush for nothin'."

"Max, you're crazy. A gallon would paint the car I'm sure."

"Well, this ain't going to be any skimpy job. Me I would feel cheap to have the car half painted and when I go to get more paint to have Isadore tell me that on account of the mayroon trees dyin' suddenly or the linseed oil wells bin closed down on account of a strike by the bakers' union, that paint has gone up and would cost me six doliars a gallon."

Max rolled the car out of the garage into the back yard and opened a can of paint.

"Say, Max," called Rachel from the kitchen door, "ain't you going to put on a old suit or overalls or somethin'?"

"No. I only work on this an hour or so before I go by the store, so there is no use puttin' on an old suit, and as for overalls, believe me, as a clothing merchant I don't like 'em any more."

MAX dipped his brush deep into the paint and lifted it out with the paint dripping.

He slapped the brush on the side of the car and a liberal quantity of the mixture splattered in all directions, a few drops taking him in the left eye. Max lifted his right hand to remove the foreign substance to allow clearer vision, but he forgot the brush, with the result that the paint oozed down the back of his neck and outside his coat.

"Hey, pop," yelled Abie, "you don't want to put so much on the brush."

"Abie, you shut up with your adwice. You just run in the house and tell mommer to send out some rags."

With Abie's help Max removed the paint from his face, hands and coat, and resumed operations. By degrees he became more skillful in the operation, learning by experience that an overloaded paint brush will leak, but before his determined hour had passed, the running board, his clothes, shoes, and concrete walk all were spotted and splashed with maroon.

As his neighbors passed they made remarks as neighbors will, usually, "Ah, Mr. Rosenheim, painting your own car, are you?"

Max grew tired of this absurd salutation and finally when Cohen leaned over the fence and remarked, "Hey, Max, what you doin'? Paintin' your car?" he laid the brush carefully on the grass, wiped the paint from his hands and said, "Cohen, come here a minnut. I want to tell to you somethin' special."

COHEN entered the yard and Max escorted him behind the garage.

"What is it, Max?" he asked in a whisper.

"Cohen," said Rosenheim solemnly, "you have known me for twenty years, and ain't I a man whose word is to be relied on abserlutely?"

"Sure, Max, everboddy knows that."

"Well, Cohen, I'm glad to hear you say it. I am rejoiced that all my old friends have such a confidence in what I say, and I ain't considered a liar. I'm going to tell you somethin', Cohen, and I know that you'll be willin' to believe me, no matter what the appearances are. You will believe me, won't you?"

"Sure, I will, Max. What is it?"

"Cohen, just now you stopped and looked at me and asked me if I was paintin' my car. Now, Cohen, man to man, with no intention to deceive, I tell you honestly and frankly, I am," and Max walked back to where he left his brush, while Cohen strode angrily away.

Max succeeded in giving the car a liberal coat, and despite the waste, the first gallon was hardly disturbed. "It is just as I was sayin', Rachel," said Max, as he cleaned up preparatory to departing. "Them robbers don't use hardly any paint at all, you

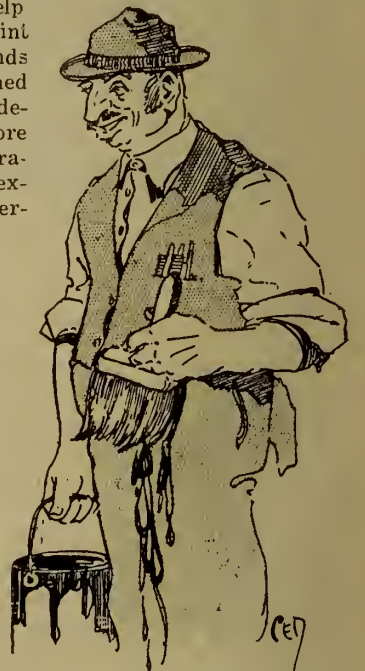



see, and they wanted to charge me a hundred and forty dollars for the job."

"Well, you've rooned that suit anyway," said the somewhat pessimistic Rachel.

"You keep Abie away from that car, and don't let him touch the paint, and this evening I go over it again, and then in the mornin' I give it another coat," said Max as he departed.

In all probability, if Mrs. Rosenheim had not mentioned to Abie that he was to keep away from the car, the youngster would not have given the machine a thought, but with the strict injunction not to go near it, as the novelist would say, he was intrigued by its fascinating possibilities, and hovered in the neighborhood wistfully, constituting himself a guardian.

Mrs. Mulcahy arrived for the purpose of doing the Rosenheim washing, accompanied by Mickey, about Abie's age. Mickey headed for the automobile at once, jumping on the running board and of course getting both hands on the fresh paint.

"Hey, Mickey, come away from the car already, or pop will be sore," called out Abie.

"Ah, I ain't a goin' to hurt yer old car. Gee, but de paint is fresh, ain't it?" said Mickey looking at his bedaubed hands. "Say, Abie, gimme a brush full of paint and I'll give her a swipe where me hands rubbed de paint off."

ABIE, however, refused, and Mickey now fascinated with the idea of wielding the brush, ran to the garage and returned with paint dripping in his wake. Abie, horrified at the act, ran forward and attempted to dissuade him, and in the struggle the paint went everywhere but in the intended spot.

The strong arm of Mickey's mother separated them. "It's a nice pair of young hoodlums ye are, ain't you? Go long now and clane yer hands and faces and hilp me with this clothes line."

Of course the car was squarely across the right of way for the clothes line, between the kitchen porch and the garage, but since it was forbidden to touch the machine the laundress thought it would be all right by having a long clothes prop.

This arrangement was apparently safe for Mrs.

Rosenheim's georgette crepe waist cleared the car by a good foot.

By this time Mickey and Abie had forgotten the car and their dispute, and were playing amicably a game called, "Tag, you're it." Abie was "It" and



came around the corner of the kitchen at high speed, pursued by Mickey. In his haste to escape, Abie collided with the clothes prop, and the filmy waist draped itself over the hood, where the paint was freshest.

"What Max will say, I dunno," said Mrs. Rosenheim as she peeled the ruined garment off the hood, "and who should get the blame? Max for leavin' the car out like that, me for not sendin' such a vallyble piece to a good laundry, Abie and Mickey for playin' such a foolish game, or Mrs. Mulcahy for not havin' sense enough to hang somethin' cheap in that spot."

THAT night, the seven gallons of paint that was unopened, disappeared, but Max took the loss philosophically, because it was evident that it would not be needed. It wasn't, for with the car finally painted, about a quart remained.

"It's a shame to waste it," said Max thoughtfully, "I guess I paint the fence."

Without consulting Rachel regarding the desirability of having a fence painted to match the car, Max began his labors, the paint being exhausted when he was about half through. "Now, to finish it I have to buy more," and he sent Abie down for another gallon. When the fence was finished he again had a surplus, and decided to paint the garage. Again he ran out of paint before finishing the job, and another supply had to be procured. "I hope I come out even this time anyway."

He did, but not just as he figured.

Max was on the step ladder giving some finishing touches to the top of the garage door, with Abie as an interested spectator. Around the corner from the alley came a frightened cat pursued by a dog. The dog in his haste did not swerve when he reached Abie. Max gave a yell as the step ladder toppled, and down he crashed, hitting the concrete with a grunt and Abie, the unfortunate, received all that was left in the paint can.

ACCORDING to Rosenheim's figures the cost was as follows:

Ten gallons of paint .....	\$ 30.00
Paint brush thrown in for nothin'.....	0.00
Suit of clothes, fair condition .....	80.00
Broken step ladder .....	7.00
Abie's new suit, total loss.....	40.00
Doctor's bill .....	16.00
Mrs. Rosenheim's georgette waist fell on hood while paint was wet. Total loss	15.00
	<hr/>
	\$198.00

"Seein' you could have got a first-class, number one job of paintin' on the car done for a hundred and forty dollars," said Rachel, "I don't see as how you saved much money. And Max, the car looks worse than ever, and if you expect me to ride in it I tell you right now you got to have it painted by a man who is a reglar painter."

# The Story of a Remarkable Salesman

By H. G. WEAVER

LAST July in a certain section of the country just as far away from the midwest automobile manufacturing belt as a state could be located and still gain admission to the Union, a company was organized for the purpose of building motor cars. High-class motor cars these were to be, nothing cheap, nothing tawdry, cars that would meet the fastidious demands of the newly rich.

Among other visible assets of the company was a young fellow who had the habit of *doing things*.

He was rather a boastful sort of a chap, too, but boasting with him was something of a virtue, because he followed it up with real *sweat* and he usually made good on his claims. He was a big man with the new organization. He was going to do the purchasing, superintend the factory, chase material, and look after sales and advertising during his spare time! He assured his associates that it would be easy to get some cars built in time for the January Chicago Show—surest thing he knew—and he got on the train and went to Detroit—went to Detroit to buy material.

And there's where the rub came; in Detroit he got a big jolt!

He was ready to buy and had the money to pay and his company to back him up, but the part makers were not in a position to sell. They were running behind schedule on outstanding contracts. The demand for high quality units was greater than the supply. They did not become infected with his enthusiasm, not even when he showed them clippings from his home town paper! They couldn't handle any more business, and frankly told him so. But the embryo car builder just simply couldn't see their side of the story. The law of supply and demand meant nothing in his young life—what he wanted was delivery dates on axles, motors, and frames.

For three weeks he besieged them. For three

weeks he coaxed, persuaded, begged, pleaded, cajoled, wheedled, beseeched, and threatened. For three weeks he listened to learned discourses on labor troubles, traffic congestions, steel shortages, reconstruction periods, and Bolshevism!

He went to Cleveland.

There again he put forth his best efforts and again he got the same answer. He stormed, fussed, and fumed, but without result.

Then, leaving turbulence in his wake, he moved eastward, eastward to New York City, still in quest of material.

En route he caught a severe cold, which settled in the side of his face, resulting in an abscessed tooth.

ON the day following his arrival he took a few minutes off and dropped into a quick service dental parlor. It was one of those places with the latest 1920 model false plates artistically displayed in the show window.

He had his tooth extracted, came out from under the gas, blinked his eyes a few times, and then hustled over to Newark, where he had a business appointment.

That night his face swelled up. The next morning he was taken to the hospital with a terrific fever. An X-ray photo showed an infection of the entire lower jaw. He was out of his head for several days. A nurse, a dentist, and a surgeon attended him constantly.

Blood poison set in. It was necessary to extract all of his teeth, scrape out the sockets and remove a piece of the jaw bone.

Time slipped by.

Before he was able to talk he supplemented his corps of attendants with a stenographer and kept a telegraph messenger busy for several hours.

Eight days later he left for Detroit on a stretcher.

He arrived in due course, whereupon he had the nurse call up everyone with whom he had formerly negotiated, and, without disclosing any names, she succeeded in getting them down to the hotel. They were escorted into his room as they arrived. He reclined on pillows, presenting an entirely different spectacle than formerly. His cheek bones protruded, his jaws were caved in, no one could have recognized him.

With great effort he spoke. His voice was weak. Slowly, but firmly, he again told them of his company, its needs, its aims, its future possibilities. He insisted on parts and units. Again he told them what he wanted, what he must have, what his company expected of him and what *they* must do to help him.

—and he finished his remarks by saying that he wasn't feeling so good, couldn't talk much, didn't feel like going out to their factories, so would just leave the matter in their hands and depend on them taking care of his requirements.

And right before them, then and there, he had the nurse wire his office that material from each of them would go forward immediately!

—and he lay back on the pillows and opened his mouth, *opened it wide so they all might see*.

The doctor came; the visitors excused themselves.

\* \* \*

Three weeks later the patient was able to return to his factory.

Some of the parts had already arrived. Correspondence indicated other material en route.

The cars were built and tested. The show jobs

*Continued on Page 38.*



Battery work is becoming an important and necessary business with the modern garage man. It is a branch which he cannot ignore, especially since the Ford car is being equipped with a device. The articles in this series are planned to help our dealer readers get a real grasp of battery repair in all its phases.

The first three articles dealt with general details, testing, and taking the battery apart. The present article describes how the battery is assembled and gives some valuable hints. We hope to publish a concluding article on charging and general repairs.

## DETAILS IN STORAGE BATTERY SERVICE

### Article No. 4—Re-Assembling the Battery

By A. M. GLOVER

sharp knife. Have the knife sharp or it will not cut the separator but split it up the grain.

More than likely, it will be found quite easy to insert the group in the jar now, but, if it is a little too tight, the jar should be warmed either over the torch or with the steam or hot water. If this is not done the jar is likely to cracked at the corners, for when cold it is very brittle and a very small pressure will crack it. Before beginning to put the groups in the jars, have them all ready so that all the jars can be warmed up at once and the whole unit put together while warm. This will give the jars a chance to conform to each other and be a good tight fit in the box.

We have now the groups in the jars, and in the right position so that the negative post of one group will join up to the positive group of the adjoining cell.

Before finishing our assembling, we want to find out if our work has had the results we aimed at, and now is the time to do it.

**F**ILL each jar with electrolyte of 1,300 strength until the plates and separators are completely covered and make temporary connections between the cells as they will be when finished, and put the battery on charge at a low rate for twenty-four hours. Immediately after the acid has been put in the cells, the strength will be found to fall to about 1,100 or 1,125 and a chemical action can be seen to be taking place. Until this action has ceased do not give the battery a charge but if it is allowed to stand overnight it will be all right.

After it has been on charge for 24 hours at a low rate of from 4 to 6 amperes the strength of the acid should rise again to 1,300. If it does not there has been some error in assembling, the probable fault being that a separator has been missed, causing a short circuit. Or it may rise above 1,300 in which case some must be taken out with the hydrometer syringe and distilled water added to replace the acid

taken out. Give the battery a short charge to mix up the solution and test again repeating the operation until the acid is the right strength.

At this stage each cell should show a voltage of  $2\frac{1}{2}$  and hold this after the lights have been burning for some time. It is a good plan to fit up a socket so that wires can be attached to the battery, and a lamp left burning on it for 10 to 12 hours and then test the voltage before finishing the assembling. Everything is now ready for the finishing touches, so take the tops and if the old seal has not already been cleaned off do this by warming them up, and scraping, in any case warm them up until they are pliable placing them over the posts and inside the jar in their original position.

Now, warm up the seal in a kettle without a soldered bottom, for it will need to be too hot for soldered bottom, and when it is just running nicely pour it around the edges of the top cover and posts, smoothing it off afterwards with the acetylene torch taking care not to burn the hard rubber parts.

**W**E have now to put on the cell connectors and the terminals. Build up the posts if they are short by burning on new lead by means of post builders supplied by the battery manufacturers, and be sure and get a good connection between the old post and the new one. Now we have the posts projecting about  $\frac{3}{4}$  of an inch above the cell covers and they need joining up with lead connector. Take the old ones, scraping off the inside of the whole until it is quite clean—cleanliness is quite as important in lead burning as in soldering—and place same over the posts in the correct position and the same as originally. Now, melt down any post remaining above the connector and make a good connection between the post and connector before trying to make a finish as the good connection is far more important than tools. Care must be taken to keep the heat as far from the edge of the connector while burning same to the post or the edges will fall away and you will have to start all over again from the time of building the post.

To prevent the edges of the cell connector getting too hot use a slow flame on the oxy-acetylene torch until you are thoroughly familiar with the peculiarities of lead burning and play the point of this flame in the centre of the post working outwards by means of a spiral motion and then back to the centre. By this means the post will be kept in a molten state and the outer walls will keep cool enough to hold their shape and keep the molten lead in place. This operation in assembling is the one that needs the most experience and it would be wise to practise on some old posts and connectors before attempting the work on a customer's battery.

**A**LWAYS be sure that you have a perfect connection for unless you do the battery will give very unsatisfactory service and the trouble will be hard to locate.

When putting on the final connections for taking the cables leading to starter, etc., be sure and get them at the same angle and in the same position as originally as these cables are stiff and will not fit properly into a terminal that is at the wrong angle.

It must be apparent to even the most casual reader that the great thing in battery repair work is to make sure of one operation before proceeding to the next. If you are not satisfied with an operation and have a suspicion that all is not right stop and investigate carefully. It is better to lose a little time in the early stages of the repair than to be faced in the end with a dud battery.



—From New York "Tribune."

What will happen when they meet?

**W**HEN you have the new groups of plates and separators to put into the battery the first thing to do is to get the unit for each jar ready. To do this, take a set of positive plates in one hand, and a set of negative plates in the other. The negative group will have one more plate than the positive, so that in placing them together there will be a negative plate to start with, and also to finish. Now place the jar cover over the two posts; this will keep them in the right position when the top is placed in position after the group is inserted in the jar. If this is not done the posts will be found too near or too far from each other to take the cover properly when you are ready to put it on and it will then be impossible to move the groups without taking out all the separators.

With the plates and jar cover in place, lay them on their edge and begin inserting the separators. A start must be made from the centre to do this, and by the time they are nearly all in it will be found that they are hard to insert. It is a good plan to use a strip of wood about an inch wide and 6 in. long to press them into place, as they are very fragile and easily broken. The corrugated side of the separator must go next to the positive plate to allow the gases thrown off the plate, when battery is being charged or discharged, free movement. It is always well to check up the group to see that there is positively a separator on each side of each positive plate. If one is missed it will ruin the whole job and it is surprising how easy it is to miss one. If a separator should be cracked in inserting, do not pass it, as it will soon be the cause of a short circuit between the plates and the fungus-like growth forming through the crack between the plates. Also take particular care to have the separators come at least a quarter of an inch above the plates, so that should anything be dropped in the battery after it is made up, it will not lie across the plates to cause a short circuit, but will rest on top of the separators out of harm's way, or between them and only touching one plate which could not cause a "short."

**W**E now have our group assembled but more than likely it will be found that the plates are spread apart and the group is too wide for the jar, and the separators project out at the sides. To overcome this trouble place the whole group in a press with lead or wood face plates and squeeze the whole good and tight and while it is in the press and held tight, trim off any projecting ends of separators with a good



# What the Tractor Can Do in the Fall

"SATAN finds some mischief still for idle hands to do," says the old adage, which, if true, means that Satan is setting a good example for farmers to follow with regard to their farm machinery. That is, they should find something for it to do so as to keep it from standing idle so far as is practicable—not mischief, to be sure, but useful work.

There are few industries in which machinery is idle during so large a part of the year, on the whole, as in agriculture. On most farms, the equipment is used only a few days each year and this fact makes the daily charge for the use of the various machines comparatively high, yet at the same time the small

By ARNOLD P. YERKES

great many more days per year than he ever dreamed of when he purchased it, and by noting the experiences of others, he can often go them one better.

During the last few years the perfection and wide introduction of small sized threshers, which sell at prices low enough to permit even a small grain grower to own his individual threshing outfit, has furnished a great deal of belt work for medium sized tractors which owners had originally bought principally for field work, but which often proved almost invaluable

quently cases where the use of the tractor for buzzing wood, pumping water for irrigation, drainage, etc., may provide several days' work each year.

But "busy work" with the tractor in the fall is not entirely limited to belt operations. If all the other farm work has been completed before the ground is frozen, the tractor can often be used to excellent advantage in clearing up brush land, filling ditches, grading rough land, and other similar jobs which add to the value of the farm and increase the tillable acreage.

Then there is the moving of buildings and other heavy objects—this kind of work is often very profitable. And, while the tractor cannot compare with the motor truck for efficiency in general hauling, there are cases and conditions where it can be used to great advantage for hauling.

IN an article of this length it is impossible to even touch upon the numerous other odd jobs for which the tractor may be used. It has accomplished its purpose, however, if it succeeds in causing some dealers to instruct their tractor owners to give careful consideration to the possibilities of using tractors during the slack fall and winter season, for if such consideration is given it is a certainty that a great many jobs will be found for the tractor, and incidentally more sales for the dealer.

It is quite common to find tractor owners who bought their machine for the purpose of getting their plowing and other field operations completed in proper season and who for the first season or two scarcely give a thought to other kinds of work for which the tractor might be used. However, as time goes on and they become better acquainted with the tractor and its possibilities they begin to make use of it in dozens of ways which never occurred to them when they bought the machine. This partly accounts for the interesting fact that in nearly all investigations which have been made to ascertain the value of the tractor for farm work, it has been found that men who had owned their tractors for two or more seasons used their machines a greater number of days per year, on an average, than owners of only one season's experience.

## Flax-Pulling Harvester a Success

UNDER the supervision of R. J. Hutchison, chief of the branch of the Department of Agriculture, Ottawa, a test of a new flax-pulling machine was recently carried out on a farm at Jeanette Creek, near Chatham, Ontario. The test was the first of its kind performed in Canada and experts in attendance were highly satisfied in every respect with the results. The machine was the Vessot flax harvester, the product of the Perfection Flax-Pulling Machine, Limited, of Toronto, Ontario.

The machine is designed to take the place of 40 hand-pullers and in the present test pulled an acre and a half of flax in two and a half hours.

Mr. Hutchison, commenting on the first day's demonstration, said that the machine was doing excellent work and under test proved that at last we had a perfect machine.



Tractor operating a small thresher.

amount of work done per year does not materially lengthen the life of the machine in years, as there is a certain amount of deterioration whether the machine is being used or standing idle.

The only purpose in selling and buying machinery is to have it earn more money for its owner. No machine earns while it is standing idle, and it is a function of good management to keep the equipment engaged at profitable work during as many days of the year as is practicable.

In the case of many machines there is little that can be done to increase the number of days during which they can be used. Take the grain drill for example, there is only a certain amount of drilling to be done, after which the drill must stand idle until the next season, and so with most other machines. The tractor, however, is not in this category. Its wide range of usefulness and ability to perform so many kinds of work makes it comparatively easy for the owner to keep it engaged at profitable jobs a great many more days each year than most other farm machines.

The tractor is a power plant and should not be considered in the same way as other items of farm equipment. It should be regarded much the same as the work stock. No farmer wants to keep in his stable a large number of work horses which he will use only a few days each year—he will either reduce the number of horses kept or arrange so as to provide work for them. Just such a plan should be followed with the tractor, and fortunately it is even easier to provide employment for the tractor than for work stock, because the tractor can be used for so many kinds of belt jobs which are entirely beyond the province of the horse.

THE most profitable tractor, other things being equal, is the one which does the most work per year, and a great many tractor owners fully realize this fact. This has resulted in many of them devising plans which provide for a large amount of profitable work for the tractor during the seasons when it cannot be used for field operations.

The odd jobs which tractors do on various farms are so numerous that a complete list would fill a page. It is, of course, impossible or at least impracticable for any one farmer to use his tractor for all of the jobs which we find tractors performing, but by noting what other men have been able to do with their tractors and endeavoring to profit by their experience, it will often be possible for a tractor owner to use his tractor to excellent advantage for a

in enabling the threshing to be done at just the right time and at a minimum expense. The use of the tractor for this purpose has become so common that it scarcely need be mentioned.

A less common use, but one which has proved to be quite valuable on many farms, is the use of the tractor for grinding feed where considerable livestock is kept. As every farmer knows the increased feeding value of feed, through grinding, is usually more than sufficient to pay the cost of the work and a tractor offers an excellent means of doing this work on the home farm at a minimum expense and with really less labor than would be required to haul the grain to a neighboring mill for the purpose of having it ground, a practice which has not been uncommon in some sections.

IN localities where only a few tractors are owned, tractor owners very often find a small feed grinder or flour mill not only of value in grinding their own grain but are enabled to do considerable custom work for their neighbors, thus providing profitable employment for themselves and the machine on days during slack seasons.

There are numerous other kinds of belt work such as silo filling, corn shelling, fodder shredding, hay baling, etc., which are found on certain types of farms in some sections. And there are not infre-



Tractor on belt work operating a stone crusher.



# The LIVE Dealer is an "All-Seasons" Man

Success Comes to the Agent Who Goes Out After the Business

TO strike right at the root of the thing the great bulk of implement men seem possessed of the hallucination that to succeed all that is necessary is to establish a warehouse with a dinky little office in one corner of it, put in a nice, comfortable swivel chair and wait for business to come to them. In countless numbers of warehouses visited these men are to be found—waiting. They invariably believe, too, that business cannot be done in certain seasons of the year.

Walk in on one of these dealers and ask him if he employs any special methods of drawing business, and you have him floored at the outset. Many will argue that it does not pay to urge the farmer to buy; that he knows his business, and that when he wants any implements he will come in his own good time and buy them. They argue that their game is to wait until they come. They state that they cannot go after business because in their absence a customer might come to the warehouse and they might lose a sale. They can't afford to keep an assistant who would stay in the office, they say. They depend for a living largely on the business done in the spring months of the year.

To such a dealer the argument was advanced that a wholesale house would soon go broke if it simply waited for business to come to it, but he was right there with the alibi that it was altogether a different case.

Meantime, while these dealers are waiting, what happens? The farmers, with more money to invest than ever before, are looking for more up-to-date appliances. Not being constantly invited and urged to replace their old equipment of worn-out implements, or go in for modern methods of farming with tractors, individual threshing machines, gasoline stationary engines, power pumping outfits, lighting systems, or any of the lines that the implement dealer has for sale, they, perhaps, buy more land, buy their equipment from the mail order houses, and lay out money for phonographs and other things. Somebody gets the money, and you can lay a dollar to a doughnut that it is the man who goes after it.

AND this suggests that portion of the story which deals with that section of the trade who are out after business and who invariably are getting it.

The first thing that puts you wise to the live wire dealer is that he is an advertiser. Not only does he advertise his goods in the newspaper, using all those helps provided by the manufacturer, such as cuts and prepared literature of a high class, but he advertises himself. He is usually a man of some personality, self-developed through his pushing proclivities. He is a good mixer, he cultivates optimism even when his business looks blue, he takes a prominent part in church and lodge life, he takes part in the affairs of the town—in brief, he seeks by every means in his power to make friends, and in a country district, friendship is nine-tenths of the battle. The successful dealer is always an "all-season" man. He tries to forget that there are any seasons, for he aims to put in so many sidelines that there will always be a big demand for some article he carries. He goes by the principle that if you can get people coming to your

By F. H. SWEET

shop on any pretext, you are establishing custom and building up trade. And so he takes several trade magazines, and is constantly "taking his pen in hand" to inquire about new lines that are being placed on the market, and to seek the agency for them in his town and district. He is not fussy about whether the new line is closely allied with the implement business. The main thing with him is to get the coin, and when he has stocked up on all the lines of implements, tractors and automobiles he can carry, consistent with the trade offered and crop conditions, he goes in for gas engines, pumps, lighting systems, auto acces-

to one who is already overburdened with debt. The successful implement dealer is usually to be found located in a prominent position where he can display his goods to advantage, for this business is the same as any other in that respect, and goods well displayed brings buyers. Even a side street location can be made by erecting an elevated platform for the placing of the various lines offered, by the use of a little paint, and by some good painted signs. Coupled with the display of goods a live dealer will have a card file giving the names and addresses of all the farmers within 30 or 40 miles of his town. This he will compile from the tax lists, and from the telephone directory, and be gradually building it up. He will not only send farmers his own printed literature, but will co-operate with the various manufacturers in supplying them with lists of names for the mailing of cleverly worded circulars from the head office. He will insist upon this co-operation if it is not voluntarily proffered by the manufacturer, and they will appreciate his enterprise.

Best of all he will find a way of getting out after business personally. In these days of motor cars, it is not a difficult thing for a man to run ten or fifteen miles out into the country now and again in search of business. If it is impossible to leave his wife or son in charge of the shop in his absence, he can run out early in the morning or in the evening to offer his goods to the farmer at his own door. There will be no fear of the farmer taking offence at that. Fact is, on the word of successful dealers, he likes it. It flatters him to think he is getting a little attention, and he almost invariably opens his heart and talks business, telling of his requirements, his likes and dislikes, and becomes a friend and prospect.

And at those periods of the year that are generally described by his slacker friends in the trade as "off seasons," it will pay him to get right out after business, and spend one-half of his time on the road.

APART from everything else, the hustling implement dealer will give generous and unstinting service in the matter of repairs. Through no other agency will he make quicker friends of the farmers. He will be willing to go out at any time of the day or night, for that matter, to render service when it is urgently required in the busy season.

To sum up, the difference between the dead and the live agent is: the latter follows in the lines of all modern business by using every method and every agent in his power to invite and land trade. The very fact that he is a live wire and busy takes him out of himself and makes him more sociable and approachable. His spirit to win is contagious. The fact of the matter is that if a man is going to do business, whether he is an implement agent or a peanut merchant, he must get out and start something. Nothing nowadays comes to the man who waits.

NORWAY is the first country in the world to propose national legislation specifying that motor trucks up to two tons capacity must be equipped with pneumatic tires, so as to prevent damage to roads and to cut down the excessive cost of highway repairs due to the use of solid tires.

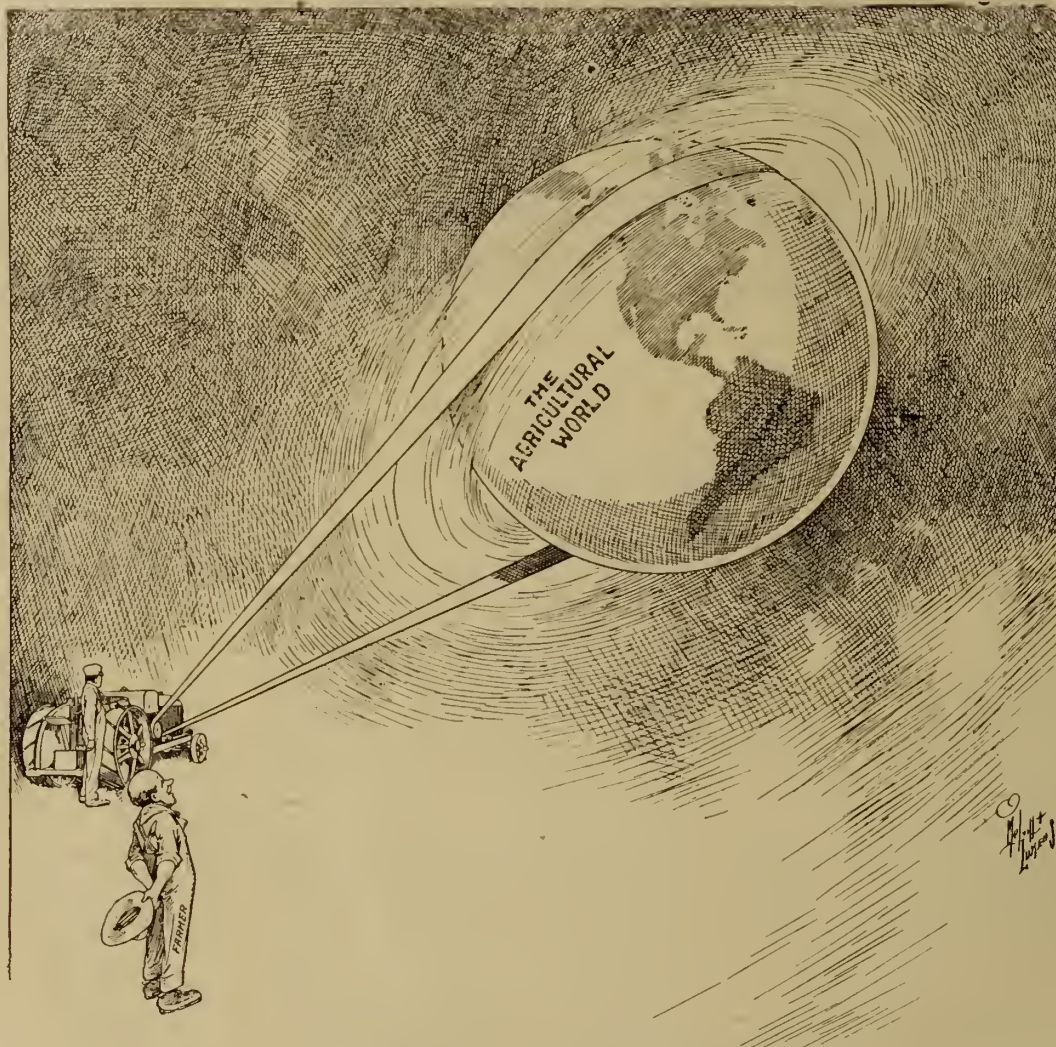

"Making the agricultural world go 'round.'"

—"Farm Implement News."

sories, power washing machines, lightning rods, hail insurance, phonographs, ranges, safes, cream separators, bob sleighs, cutters, grain crushers, fanning mills, small threshing machines, windmills, etc. He is a busy man. He looks it, he acts it, and his very activity brings trade.

One of the primary reasons for the success of this man is that he studies the need of the community. He makes a study of what implements the farmers want to deal with, the nature of the soil in that district. He never allows himself to become loaded up with dead stock through negligence in this regard. If he finds that the haying season is coming to a close, and he has a stock of mowers and rakes on hand, he sacrifices them to get rid of them rather than carry them over another year. He believes in making friends by giving an occasional bargain, and that there is money in quick turnovers.

INCIDENTALLY, the live wire is careful with his credits. He uses diplomacy. He does not rush to offer goods on fall terms without first attempting to have the farmer secure the money from the bank. He does not hesitate to gauge his man, and refuses credit



## International Threshers Provide Your Trade With Full Sacks and Clean Stacks.

Thorough separation and clean threshing—these are the things that every thresherman requires of a thresher.

INTERNATIONAL THRESHERS are famous for their thorough separation and clean threshing. Instead of the usual easy-swaying, back-and-forth or up-and-down motion of straw racks, the International combines both in a vigorous revolving motion that results in continuous tossing and turning of the straw so that every particle of grain is shaken out. This means thorough separation. The adjustable sieves and shoe clean the grain thoroughly and deliver all of it to the grain spout instead of some of it to the wind stacker.

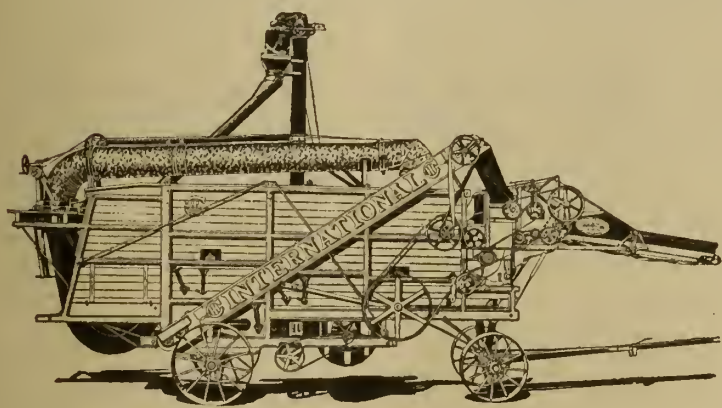

The thresher that assures full sacks and clean stacks is the thresher that sells. INTERNATIONAL threshers—22 x 38 and 28 x 46 sizes—have the confidence of the farm public. Our advertising is directing the trade to you for this popular machine. Thresher time is at hand. Communicate with the branch house and make the most of the opportunity.

### INTERNATIONAL HARVESTER COMPANY

OF CANADA LTD.

HAMILTON CANADA

WESTERN BRANCHES—BRANDON, WINNIPEG, MAN., CALGARY, EDMONTON, LETHBRIDGE, ALTA., ESTEVAN, N. BATTLEFORD, REGINA, SASKATOON, YORKTON, SASK.  
EASTERN BRANCHES—HAMILTON, LONDON, OTTAWA, ONT., MONTREAL, QUEBEC, QUE., ST. JOHN, N. B.

## The Reward of Many Years

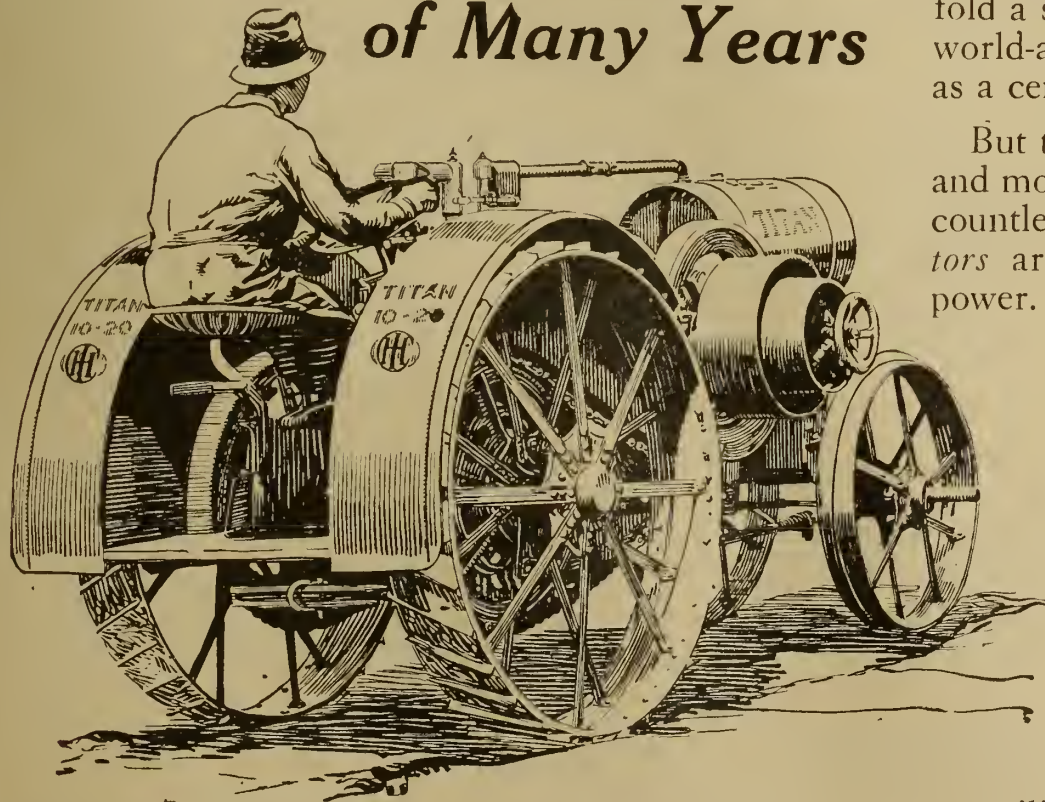

This Company has lived a remarkable history. To tell it in the way of history would be to unfold a story of many pages—a story as wide as world-agriculture and nearly as long in years as a century.

But the story is being told every day in vital and more interesting terms. It is being told in countless fields of the nation, where *Titan Tractors* are steadily turning kerosene into farm power. Here is summed up the true history of

Harvester purpose and success. It is a story of action, rather than of words.

In 1831, Cyrus McCormick placed the first reaper in the grain field and opened the way to a future full of vast possibilities. Then began a manufacturing career that has placed millions of practical machines on American farms and now finds its most modern expression in the *Titan 10-20 Tractor*.

It is no accident that *Titans* to-day are toiling the world over, to the end that farm harvests may be greater and better. This tractor is the careful product of ninety years' accumulated endeavor, experience, and contact with the problems in farming. That fact accounts for *Titan* predominance.

### INTERNATIONAL HARVESTER COMPANY

OF CANADA LTD.

HAMILTON CANADA

WESTERN BRANCHES—BRANDON, WINNIPEG, MAN., CALGARY, EDMONTON, LETHBRIDGE, ALTA., ESTEVAN, N. BATTLEFORD, REGINA, SASKATOON, YORKTON, SASK.  
EASTERN BRANCHES—HAMILTON, LONDON, OTTAWA, ONT., MONTREAL, QUEBEC, QUE., ST. JOHN, N. B.



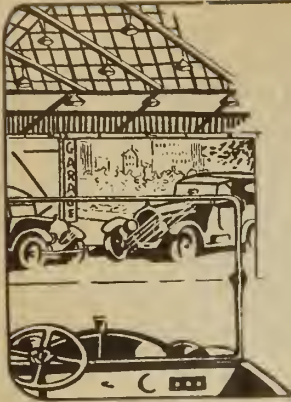

# SHOP NOTES FOR THE GARAGE MAN



## TEMPERING STEEL TOOLS

THE following hints on tempering steel tools taken from Canadian Machinery will be found useful to the repairman:

All steel tools that require tempering have to be hardened first. This is done in many ways, the tool being turned over from time to time, until it is evenly heated to a cherry-red color. It is then plunged into either a solution of plain water, salt water, or a solution of cyanide of potash in water, according to the preference of the temper. The cyanide and salt water solutions make a tool very hard. When used to turn rolls, no drawing of the temper needs to be done, the metal being ready for use if it has been previously ground. In tempering machinists' lathe tools, etc., the method adopted by good blacksmiths is to first harden the metal in the manner previously described, with the exception of not plunging all parts of the tool in the hardening solution; but leaving some heat in its shank, while the cutting edges are cold. The edges are then quickly rubbed with an old file or a piece of firebrick or emery cloth tacked upon a block of wood. This is done so that the color can be easily seen—the color travelling down toward the shank or point. When the desired color reaches the cutting edge, the tool is plunged into cold water and the job is done. Appended is a list of tempering colors, each one representing a lower degree of hardness than the one preceding it.

### List of Tempering Colors

Straw color is the hardest. Brown the next. Now comes light purple, dark purple, deep blue and pale blue.

Straw color is suitable for cold chisels where light blows are struck, or for other work where great hardness is required. Where heavy blows are delivered, it is best to temper the chisel to a brown color. Screwdrivers should be colored a light purple and springs or other articles that require to have great toughness with a reasonable amount of hardness should be tempered to a deep blue color.

There is another kind of steel on the market called "high-speed" steel. This is a most remarkable metal and is the best tool steel for roughing down work that the writer has ever used, it being of such toughness and hardness that very heavy cuts can be taken; so heavy, in fact, that the cutting edge gets red hot and it operates for a long time in that condition before requiring regrinding. The writer has also tried this class of steel for turning rolls, with the exception of chilled rolls, which the steel would not cut at all, it proved to be very fine on all other classes of rolls, enabling the work to be completed in far quicker time than the best crucible tool steel would allow. The crucible steel tools seemed to be better suited for turning chilled rolls, and also the ones containing manganese, the carbon element being the ingredient required for turning chilled work. Singularly enough, the high-speed variety of steel contains very little carbon in comparison with the crucible or open-hearth metal; it depending for its hardness and toughness upon the addition of chromium, cobalt, molybdenum, tungsten, nickel,

vanadium and other rare metals which impart to it the extraordinary characteristics of cutting metal when the point of the tool is red hot, the chip in this case coming off with a deep blue color. Each manufacturer has his pet formula for manufacturing this kind of tool steel, they using some or all of the above ingredients. High-speed steel is very expensive and on account of this fact, all shops do not use it, but the demand is increasing every year, the late war making very heavy demands on it. High-speed steel cuts the overhead cost of manufacturing down to a minimum by allowing a far greater output to be secured from machines in a day's work.

This class of steel requires different treatment in hardening, it being necessary to heat it to a "white heat," which latter would positively ruin the best crucible or any of the usual kinds of tool-cutting steels. The best plan for cooling high-speed is to do the work in an air-blast, although oil can be used. I find it will not hold its cutting edge for as long a time as when the air-blast is used as a cooling medium. This steel, unlike crucible steel, does not need tempering after hardening, as it gives the best service when left hard.

## HOLDING A ROUND SHAFT

SOMETIMES in the busy season when every available piece of equipment is in use, the repairman may be faced with a rush job which makes it necessary to hold a smooth round shaft securely to prevent it rotating while

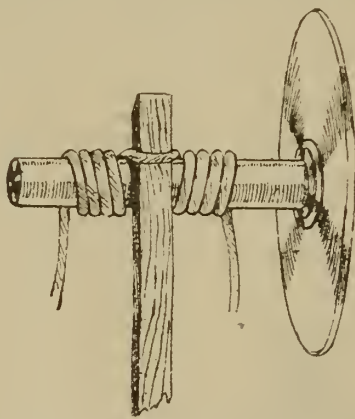

fittings are being dismantled from it. An ordinary vice or pipe wrench may not be used for fear of damaging the shaft. A simple, but effective method for coping with such an operation is to wind a length of thick cord or thin rope, according to the size of shaft, round the shaft and round a piece of timber as shown in the illustration.

No difficulty will be experienced in holding the shaft securely, if a long piece of timber be used. The rope and wood must be arranged according to the direction in which the shaft has to be turned or prevented from turning.

## HOW TO TREAT SULPHATED PLATES

IF a storage battery cell, under test, sinks to fifty per cent. below efficiency, there is of course something seriously wrong. The plates should

be removed and washed thoroughly with distilled water. After washing place them in a cell containing a two to five per cent. solution containing caustic soda in water and send a charging current through the cell.

If during the time of the ordinary charge the sulphate on the positive plate does not disappear and the solution gives an acid reaction with litmus paper, more caustic soda must be added to the solution and the charging continued until the plate has the usual chocolate appearance. When you are satisfied that the plates are clean they should be removed from the soda solution, well washed, replaced in the sulphuric acid solution in the cell and the charging continued until gassing begins. This treatment has often raised the efficiency of cells from 25 to 75 per cent. Six hours' charge should be sufficient.

## TO PREVENT TIRE PUNCTURES

IT is safe to say that during the last twenty-five years hundreds of patents have been taken out for the prevention of punctures in pneumatic tires. In most of them the central idea was to make the tire impenetrable to nails and other injurious articles," says Chambers's Journal. "A recent inventor approached the problem from a new angle by studying the process by which the nail gets in to the tire. He found that (1) nearly all nails lie flat on the road; (2) in motor-cycles and cars 90 per cent. of nail punctures are in the rear tires; (3) punctures occur most readily at high speeds and on dry roads; (4) the front tires are pierced by short nails, the rear tires by long nails.

"From these observed facts he concluded that rear-tire punctures are caused by the front tire turning objects on end, with the result that if the rear tire reaches them before they fall again, it is pierced. Experiments conducted over a track strewn with nails verified this theory; not only were the nails seen to act thus, but they were caught 'red-handed,' as it were, by a high-speed camera. The puncture-preventer designed as the outcome of these observations and experiments turns down nails as fast as the front tire turns them up, and so the rear tire is saved. The form of it suitable for motor-cycles consists of a specially constructed rubber canvas flap, 3 inches wide, usually mounted on a scroll spring attached to a curved steel bracket fixed by one bolt through the end of the rear mudguard, but occasionally attached to the silencer or to a special adapter. The flap 'covers' the rear tire, and clears the road by half-an-inch. It lasts for about 25,000 miles and can then be removed cheaply.

"The puncture - preventer has kept the inventor free from punctures for 25,000 miles; previously he had forty-seven in 11,000 miles. On one occasion he rode for seven hours over a track strewn with thousands of nails. So long as the apparatus was in position, no damage was done; when it was removed, rear punctures came thick and fast. Forms of the preventer suitable for motor-cycles are already on the British market; models suitable for cars and cycles will be ready shortly."

## BATTERY BENCH

IN these days when battery repairs are being done by practically every garage man, a hint as to what kind of bench should be used may perhaps be helpful, as everybody knows the acid used in a battery is very powerful and will, in time, destroy an ordinary wooden bench. To overcome this the bench should be covered with sheet lead and graded slightly so that the acid as it drains from the battery will be carried to one corner where a hole is cut in the bench. A lead pipe is led from this hole to a large earthenware receptacle underneath the bench where the acid is caught.

Another type of battery bench which will be found serviceable is made by cutting a square hole in the top of the bench slightly larger than the largest battery. This hole is covered with a grating and lead-lined tank is placed underneath provided with an outlet for draining the acid.

## REMOVING STUBBORN NUT

A NUT which has become rusted in place will often resist the ordinary methods adopted for removal and other methods have to be employed. A good method for removing such a nut is to heat a large nut that will fit over the stiff nut and let it rest around the stubborn member for a few minutes. The heat will generally expand the nut without producing expansion of the bolt and it may be unscrewed. Kerosene may be poured around the threads with good effect. Several alternate heatings and applications of oil may be necessary before the nut is loosened. A light tapping with a hammer on all the facets of the nut will help to loosen it on the threads.

## USE OF BLACK JAPAN

A TIN of black Japan is most useful in the garage, particularly with a new car. It is sufficiently liquid to hide brush marks, but dries so quickly that if thinly applied it will not run into blobs. A 1 in. hat oil brush, and a small water color brush for touching out minute chips on wings, if these are black, should be used. There are generally small plated pieces on most cars that cannot be polished, and some plated butterfly nuts that are of such poor quality that the rust comes through at once. A little thought will easily decide what parts are best painted over, but a few typical places are name plate and butterfly nuts on accumulator box; all armored electric cables, except the last length to the lamps, if these are plated; name plates on black lamps; and the whole of the tail lamp, if brass or plated, as it is impossible to keep this polished. If black, the change-speed lever, brake lever, and pedals will be improved by receiving a coat.

A new chassis is often very roughly painted, and patches of rust will appear after the first wash, if not before, especially on odd bolt heads. These should be painted over, while a thick coat applied to the thread of any chassis bolts from which the nut is likely to jar loose after the latter has been screwed up is often as good as a spring washer.—Autocar.



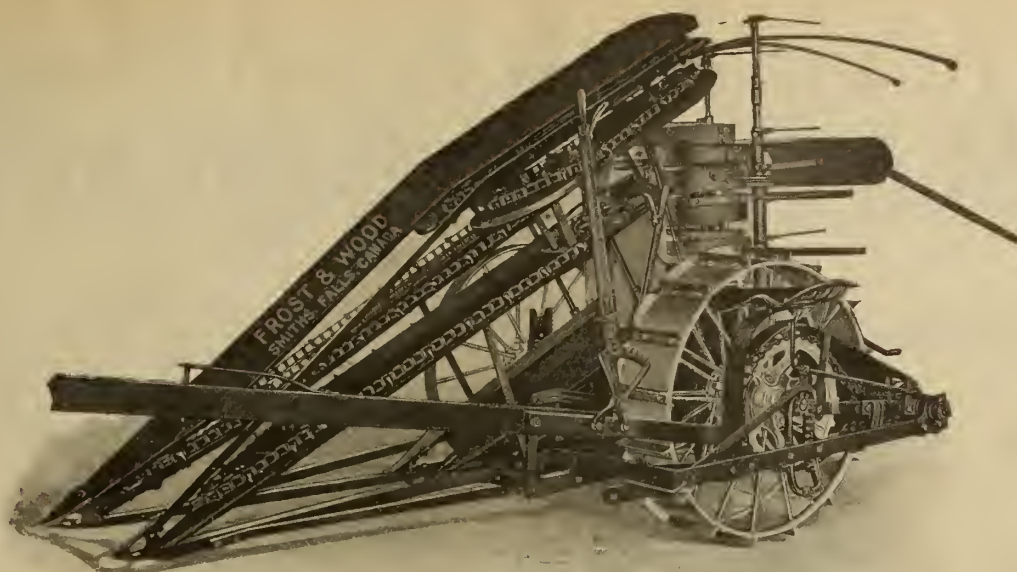

# Frost & Wood Corn Binder

If you have customers who grow corn in quantity you can count on ready sales for the Frost & Wood Corn Binder. It is the great, modern, Frost & Wood answer to the farmer's annual corn problem—"How can I get my corn crop in without 5 or 6 men at the job—just when it is ready to cut, which means just when its feeding value is highest." And more—it is the Binder that cuts and bundles any kind of crop, lodged and tangled as well as straight and easy.

**"Corn is King"—and the splendid, modern design of this machine shows our appreciation of it**

The Frost & Wood Corn Binder is built for long service, lots of it—even in the hands of an inexperienced operator. It is light in draft—like all Frost & Wood Implements—because we believe in using only the highest grades of steel and wood and because we use high grade roller bearings at every friction point and provide plenty of dust-proof oil cups.

Take a look at the main frame illustrated here. See the substantial bracing and riveting. Large, heavy castings hold the horizontal and vertical shafts in place. They do not bind, run hard or stick.

Main drive wheel and grain wheel are same size, preventing jarring on uneven ground. Long dividing arms work close to the ground. The elevating, cutting and binding attachments work smoothly — no choking or sticking. Adjustable to thin and short or long and heavy crops. Thoroughly tested and tried out before it leaves our factory, guaranteeing efficient field service.

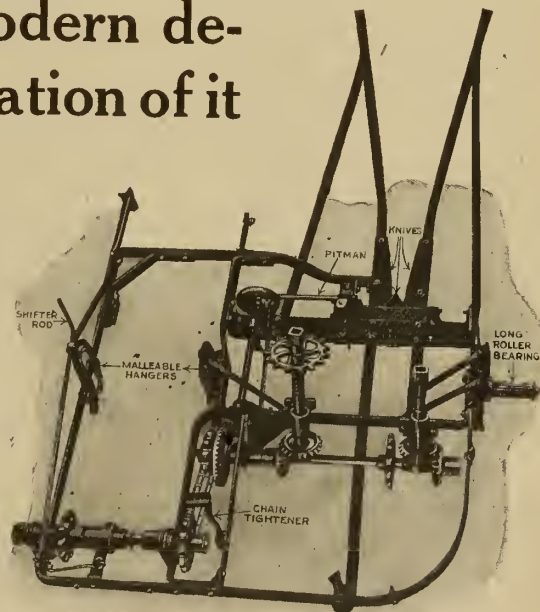

This main frame of the Frost & Wood Corn Binder is worth your special study. Ask us to mail you copy of our folder, "Corn is King" and get the whole story.

**Our Dealer Proposition shows how you can do new and better business with a big, complete, quality line of well-advertised, popular implements. Let us send it to you.**

**The Frost & Wood Co.**  
LIMITED

Montreal SMITH'S FALLS St. John

*Sold in Western Ontario  
and Western Canada  
by*

**Cockshutt Plow Co.**  
LIMITED

BRANTFORD, ONTARIO



# Automotive Accessories and Implement Equipment

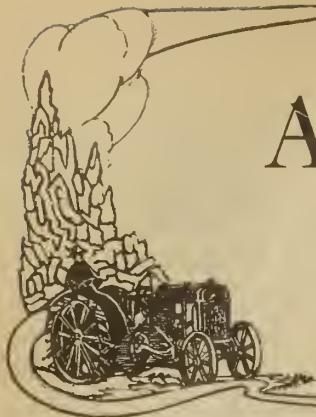

## SILENT SALESMAN

THIS accessory case is built with a small frame, highly finished. One of the features of the case, the makers say, is its indexing system, which serves as an automatic clerk. By numbering the backs of the doors and hanging up an index in a convenient location even the most inexperienced clerk by reference to the index can locate quickly any article.

The case is made of oak—the standard finish is golden oak—and birch finished mahogany. It has a beveled plate glass top, and double strength glass front and ends. The drawers are made with a wood partition that can be removed if desired. It is manufactured by the Detroit Show Case Co., Detroit.

## BATTERY DISCHARGE TEST SET

THE Allen-Bradley Company of Milwaukee, Wisconsin, have placed upon the market a storage battery test set containing many features of interest to users of storage batteries, service stations, and garages. It is a well-known fact that to judge the internal condition of a storage battery from a hydrometer reading is as difficult as to judge the physical condition of a patient simply by taking his temperature. The hydrometer in storage battery work corresponds roughly to the thermometer used by the physician. If the reading is not normal, something is wrong, but to determine just what is wrong, or where the disease is ravaging, other tests must be made. To enable the storage battery service station to render a quick and accurate opinion of the condition of a battery, a high-rate discharge test must be made, in addition to the density test, thus giving the service man an opportunity to test the battery under the actual conditions of service.

The Allen-Bradley type L2502 Battery Discharge Test Set, developed exclusively the makers say, for making high rate discharge tests of storage batteries, is a portable panel weighing about fifteen pounds, equipped with an ammeter having a range of 300-0-300 amperes, a set of test cords and clips, and an adjustable graphite compression discharge resistor.

The battery to be tested is discharged through the test set at a rate of six or seven times the normal discharge rate, and voltmeter readings are taken across each cell while the battery is discharging at the high rate. A variation among the voltage readings of the several cells, if in excess of one-tenth volt, indicates immediate need of inspection of the low cells, and when the readings obtained with this test set are compared with the hydrometer readings of the same cells, it is at once evident whether an individual cell is dead or discharged below the safe minimum; it also is possible to discover loose straps, broken connectors, damaged or buckled plates, sediment, or any of the ills of storage batteries in a moment's time. Canadian Fairbanks-Morse Company are the sole distributors of the Allen-Bradley discharge test sets in Canada.



Battery Discharge Set



Weston Fault Finder.

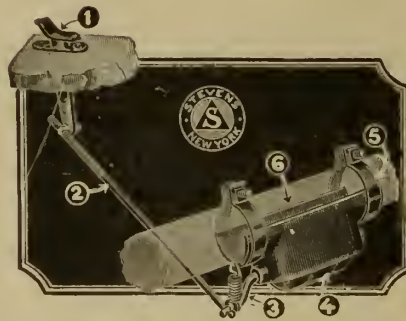

Stevens Exhaust Relief Valve.

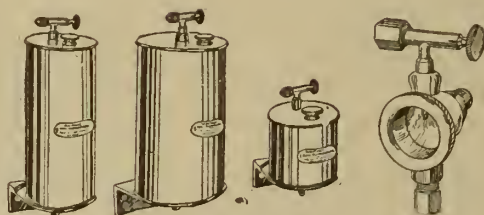

Gas Humidifier.

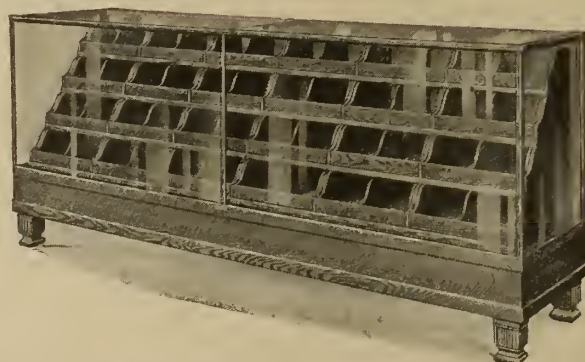

Silent Salesman Accessory Case.

## STEVENS SNAP

THE Stevens snap, an exhaust relief valve for Fords, is a simple, positive acting pedal, with direct control of extra large damper which makes a quick and efficient cut-out and motor tester. The makers say it is easily installed having no hooks or catches and its operation is very simple. The eccentric damper spring is controlled directly by an adjustable steel rod. It requires only a V-shaped cut in the pipe to install. The makers are Stevens and Company, 375 Broadway, New York.

## GAS HUMIDIFIERS

THE R. S. Whitney Mfg. Co., 74 Nichols St., Lewiston, Maine, U.S.A., are putting on the market a new device for humidifying the atmospheric condition of the gas mixture in automobile engines which they state will give the car pronounced flexibility, power and speed.

The Whitney gas humidifier is the trade name of the new device which the makers say is an upright cylindrical tank acting as a reservoir for water and by means of copper tubing, water vapor is drawn by vacuum through these ducts and a dash sight feed gauge into the intake manifold. Within the humidifier is an automatic shut-off valve placed at the lowest possible water level which checks the inrush of air into the motor when the humidifier becomes emptied of water, therefore it cannot act as an auxiliary valve if neglected.

Other features pointed out by the manufacturers are: The gauge is finished in nickel plate and is designed to be mounted on the dash or cowl board, it being piped with the motor and humidifier, acting as a constant tell-tale on the action of the humidifier, by showing the rate of feed, when the humidifier requires refilling or ceases feeding. This gauge combines no complications and enables the driver to control the amount of water-vapor entering the motor. Occasionally this valve may be opened a complete turn and the motor flushed with water, creating a steaming-out process to remove carbon which is positive in its action. It is manufactured in three models for motor cars, trucks, tractors, motorcycles; marine, portable and stationary gasoline or kerosene engines.

## WESTON FAULT FINDER

THE Weston Electrical Instrument Co., of Newark, N. J., has placed on the market a fault finder of considerable value to the garage man.

It consists of a voltmeter and an ammeter mounted in a compact case with a carrying handle and a hinged cover. It is furnished with a pair of special, flexible, well-insulated cables six feet in length. On one end of each cable is a plug terminal for making connections to the instrument while the other ends have lead covered, spring clip terminals to make rapid and positive connections to the circuits under measurement.

The Weston fault finder is distributed in Canada by the Northern Electric Company and A. H. Winter-Joyner, 62 Front Street West, Toronto.



# Kopper King

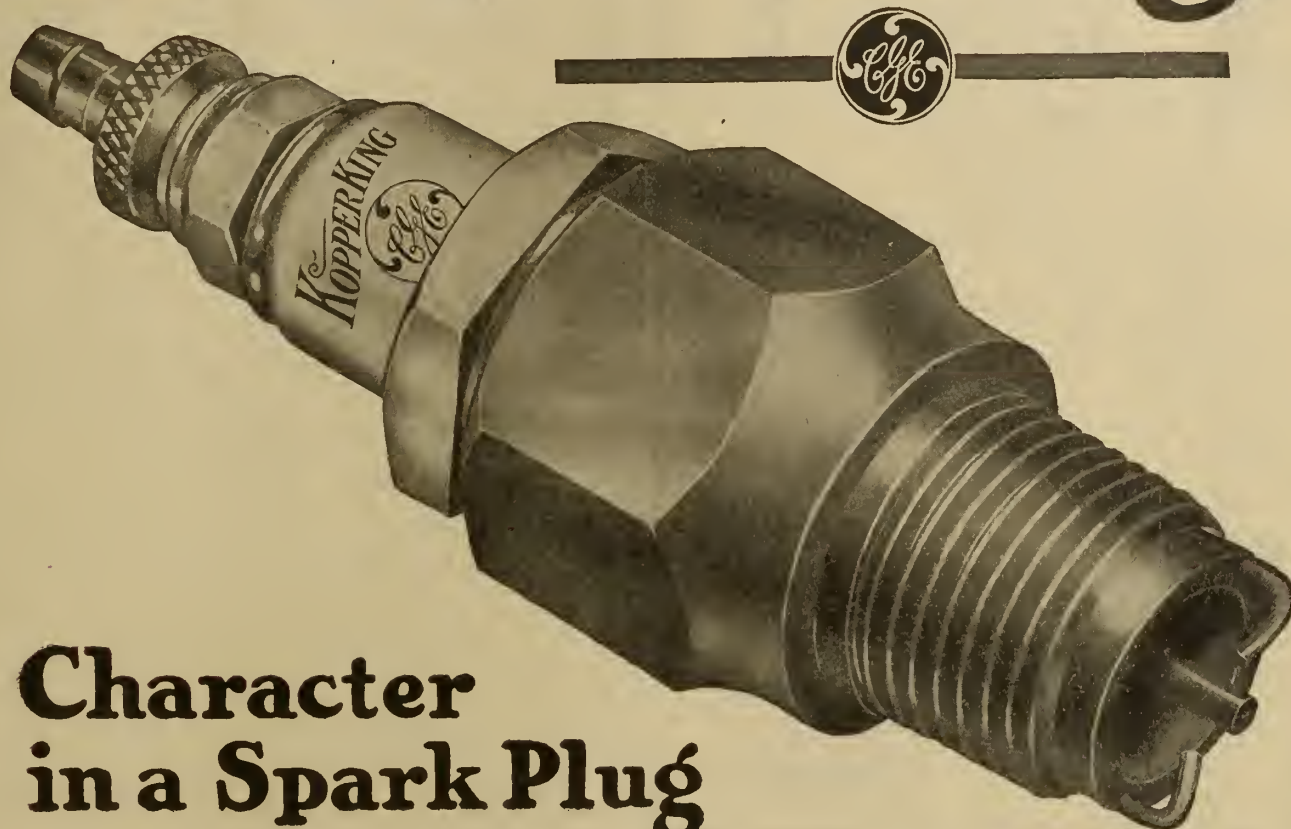

## Character in a Spark Plug

**F**IRING the gas vapor, driving down the piston-head hour after hour with an exploding sheet of flame, demands character—not mere metal and insulation—but character expressed in design, in construction methods and in workmanship.

The Kopper King is a prestige builder. Incidentally, it shows the Dealer a greater margin of profit than any competing plug. The Rust-proof Copper surface prevents Carbon deposits; carbon will not adhere to copper under Electrical Heat. The Kopper King is without a peer among Spark Plugs. It is a quality plug from first to last.

*C. G. E. Automobile Accessories are "Tested for Service."*

**Canadian General Electric Company, Ltd.**

Head Office - TORONTO

Branch Offices: Montreal, Sherbrooke, Quebec, Halifax, Sydney, St. John, Ottawa, Hamilton, London, Windsor, Cobalt, South Porcupine, Winnipeg, Calgary, Edmonton, Nelson, Vancouver and Victoria.



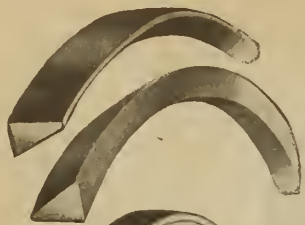

## Ensure Perfect Compression

Your customers bid a glad farewell to compression troubles when you set them right with

### EXCELLENCE TWO-PIECE PISTON RINGS

They positively prevent leakage between piston and cylinder walls, and keep spark plugs clean and efficient. They allow the required amount of oil, *and no more*, to pass for the smooth working and long life of the piston. A perfectly sealed firing chamber is the result, and every ounce of power is exerted on the piston head.

Excellence Rings are now being supplied in the following sizes: 3 3/4 x 1 1/4, 3 3/4 x 3 16, and 3 11 16 x 3 16. Other sizes will be available soon.

Manufactured exclusively and distributed by

## LAMONTAGNE LIMITED

Wholesale Dealers in Automotive Equipment

QUEBEC

MONTREAL

WINNIPEG

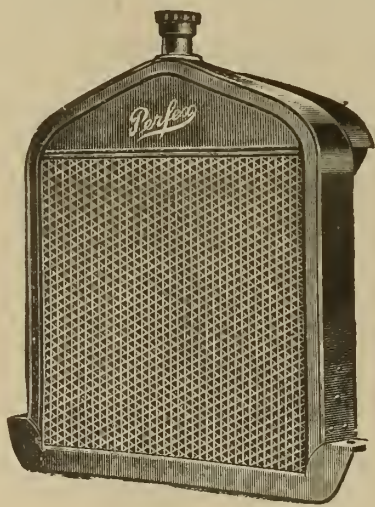

# PERFEX

*The Perfect Radiator*

Perflex radiators for Fords are a quality product embodying features that cannot be had in other radiators.

A patented spring bracket suspension and a real radiator core of great efficiency.

*The last word in Radiator construction*

Perflex Radiator Co., Racine, Wisconsin, U.S.A.

P. A. C. McINTYRE & COMPANY  
311 Confederation Life Building, Winnipeg

Direct Representatives for  
Manitoba, Saskatchewan, Alberta and British Columbia

### UNOCCUPIED LANDS FOR SALE

THE superintendent of the Natural Resources Intelligence Branch of the Department of the Interior, at Ottawa, has given out the following report:

Among the natural resources of Canada agricultural land is by far the most important, the value of field crops alone being four times as great in 1919 as that of all other raw products of mines, fisheries and forests combined.

Canada has a land area of 2,306,502,400 acres, but obviously much of this is not adapted for cultivation. Without taking into consideration forest or swamp land, much of which will ultimately be tilled, nor of unexplored northern areas, there remain at least 300,000,000 acres available for agricultural development.

Only about one-sixth of these 300 million acres are under cultivation, and 250 million are still unimproved. It is estimated that there are in Canada about 180 million acres of agricultural land in private ownership with a rural population of 4 1/2 millions; in other words, not taking into account mining, lumbering, fishing, domestic duties and other activities, each Canadian man, woman and child living outside of a town may on the average be assumed to be farming 40 acres. In Northern Europe the rural population on the same basis, but with far less widespread occupation is attending to 4 1/2 acres, per head.

To utilize the agricultural land and thus widen the basic factor of Canada's production is, then, all important, for it is on this that the development of the other natural resources depend. The day of the free homestead within easy reach of a railway is rapidly becoming a thing of the past, and means other than free grants must be looked to for rural development.

For the man who intends to farm there is, as stated above, a vast area in private ownership, a large proportion of which is of necessity unoccupied and available for sale at reasonable prices. The prospective purchaser who relies upon his own sources of information may, however, find it more or less difficult to obtain a knowledge of lands for sale suitable to his means and requirements. This difficulty is now to a large extent overcome by the publication by the Department of the Interior of lists of unoccupied lands for sale in the Prairie and Maritime Provinces.

These lists, as a rule, give a short description of the land, its location, the price at which it is held for sale and the name and address of the owner. The great value of such information is that it places the intending purchaser directly in touch with those who, for one reason or another, have been unable to cultivate their holdings and who, therefore, are often willing to sell at inviting prices.

Lists covering the Province of Manitoba and the south-eastern portion of

Saskatchewan are now ready, while lists covering the balance of the Prairie Provinces are now being compiled and will be available for distribution before very long.

As there is a series of twenty-three lists covering the Western provinces alone, applicants must specify the particular locality in which they are interested. These lists may be obtained free of charge on application to the Superintendent, Natural Resources Intelligence Branch, Department of the Interior, Ottawa.

### TRAVELLERS AS HARVESTERS

IN ORDER to assist in meeting the demand for harvest help, says the Toronto Globe, especially in the West, one of the largest manufacturers of agricultural implements in Ontario makes the following suggestion:

"All commercial travellers, in the older Provinces especially, who are able physically to work in the harvest fields should be asked to leave their beaten paths in the East and join with the harvesters to take care of the crop. It is safe to say that two-thirds of the travellers at present combing the trade could leave their route for eight or ten weeks without any serious detriment to the business of the country, while they could perform a very useful service in helping to take off the crop."

### TRACTOR DEMONSTRATION

THE Macdonald College Farm, Quebec, will this year be the scene of a Plowing Match, Tractor and Farm Machinery Demonstration, on October 12, 13 and 14. It is being held under the auspices of the Eastern Ontario and Western Quebec Plowmen's Association. It is expected that it will be even more successful than the fine demonstration staged by the same organization at Ottawa last year. The Quebec Government has promised to make a grant to the Association. L. C. McQuat of Macdonald College, is secretary of the Association and the president is John Hay, M.P.P., of Lachute, Quebec. A large program and prize list is being prepared.

### NEW FORD AUTO

A NEW automobile, bearing the hallmark of Henry Ford has just been perfected; a machine which is almost ready to be used as the pattern for millions like it to supplant the well known Ford motor car. Announcement of the new type automobile followed the payment of \$35,000,000 made by Ford recently to clear up the \$60,000,000 commercial note issue arranged by the company a year ago.

PENTICTON.—The Auto Supply Co., has erected a new garage. All repairs are done and a large line of accessories, gas, oils, etc., carried. W. Hunnabell is manager.

## Oversize Pistons

Many makes and models in stock.  
Write us for quotations and delivery  
on your requirements.

*Cylinders reground. Pins and Rings to Order*

## Advance Machine & Welding Co.

177F Canning Street, Montreal





## The Plug with the HOTTER SPARK

The ball point of the "M & S" plug creates a larger and hotter spark, causing more complete combustion. This hot spark will give your car new life and more power.

The three-in-one terminal is adapted to any style ignition wiring. The high-grade chemically glazed porcelains are interchangeable — one porcelain fits all plugs.

### Models

500—1/2" Standard
501—3/4" Standard
502—3/4" Long
503—3/4" Long with Chevrolet Terminal
506—1/2" Long
504—Regular Porcelain
505—Chevrolet Porcelain

*DEALERS--The "M & S" Plug is standard equipment on the new Overland "4." Ask your jobber for them.*

**Machine & Stamping Co., Ltd.**

1209 King Street West  
TORONTO  
Commercial Dept.  
Russell Motor Car Co., Limited

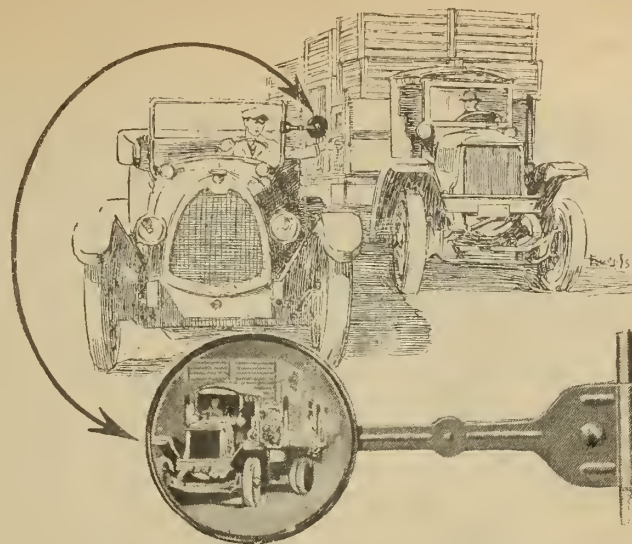

## When a Left Turn Means Disaster—

The motorist whose car is equipped with a "Hindview" drives safely.

He is able to view the traffic behind without turning his head—without losing sight of the road behind him.

## *Hindview* AUTO MIRRORS

constantly warn the driver against turning out or slowing down at the wrong time—and causing an accident.

This mirror has many exclusive selling features. A style for every purpose. Write for our folder.



*We also manufacture pressed metal parts, light and medium weight stampings, card holders, washers, shims, etc. Send specifications or blueprint for our estimate.*

**Kales Stamping Co., Limited**  
61 Walker Road  
WALKERVILLE, Ont.

# SEE THE WONDERFUL "STRAIGHT DISC"

AT THE

## Toronto - London - Ottawa Fairs

Let us show you that—

- the "Viking" has made good both in making satisfied users, and as a money-making proposition for dealers;
- we have dealers in Ontario who have sold over forty "Vikings" during the last six months;
- more good dealers have contracted for the "Viking" agency during last ten months than ever contracted for any other separator in the same length of time;
- the "Viking" way of doing business, liberal treatment of customers, fairness in dealing with dealers, and actual service rendered, offers dealers greater advantages;
- the upkeep of the "Viking" for ten years costs the customer practically nothing;
- by selling the "Viking" the dealer makes more profit;
- and that, it is the wonderful "Straight Disc" of the "Viking" which skims to 3/100 of 1 per cent. or better, that makes easier sales for the dealers.

## Spend a few minutes at the "Viking Separator" Exhibit

—watch the wonderful "Straight Disc" at work—see how it pleases the farm-wife to know that the "Viking" Straight Disc is never taken apart, but is washed as one piece, in a jiffy—let us show you the list of Ontario dealers—the number of "Vikings" sold—let us show you letters from the

Send for one of our large Circulars, to-day

Then you will know why you should not miss seeing the "Viking" Straight Disc operating, when you attend the Fair

happy, money-making owners of "Vikings"—examine every part of the "Viking" so as to convince yourself that there is no other separator that has as many superior merits to make sales easier—and your profits on each sale bigger, because of the service we render both our dealers and owners.

A few territories now open, so write us at once, and get our liberal proposition.

**Swedish Separator Co.**

422 Powers Building, MONTREAL, Que.



## THE BEST BUMPERS OBTAINABLE



"KABEE"  
SPRING ARM CHANNEL  
BUMPER

"LYON"  
RESILIENT BAR  
BUMPER

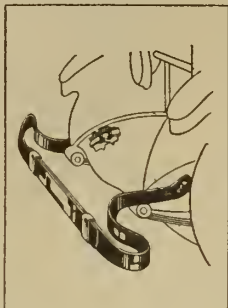

DURABLE BRILLIANT FINISH  
PATENTED "HOOKBOLT" ATTACHMENT  
FITS 90% OF STANDARD CARS  
OBTAINABLE FROM JOBBERS & DEALERS  
CATALOGUE ON REQUEST

**KINZINGER BRUCE & CO. LTD.**  
NIAGARA-FALLS, CANADA  
SOLE MANUFACTURERS, UNDER  
LYON CANADIAN PATENTS.

### CANADA'S NATIONAL EXHIBITION

The Canadian National Exhibition, Toronto, will take place from August 28th to Sept. 11th. This year again there will be a large display of automobiles, trucks, tractors and implements.

Canada's only National Automobile Show, held in conjunction with the Canadian National Exhibition, will be better housed this year than ever before. The Transportation Building has been redecorated artistically, and will be given over to passenger cars exclusively. The two demobilization barracks to the west will house the truck and accessory exhibits. These have a combined floor space nearly equal to the Transportation Building. By next year it is hoped the much-heralded Automobile Palace will be erected to house all the automobile exhibits.

The following is a list of the entries to date in the tractor and farm implement lines: Aspinwall-Drew Co., Ltd., T. E. Bissell Co., Oliver Plow Co., Peter Hamilton Co., John Deere Co., H. F. Bailey & Son, Spraymotor Co., Ontario Wind Engine & Pump Co., Monarch Tractor, Limited, Lake Breeze Co., Ford Tractor Company, Chase Tractors Company, Canadian Motors (Varna), Wettlaufer Bros., Swedish Separator Company, New Britain Machine Co., R. A. Lister Co., (Canada), Gilson Mfg. Co., Birdsall Mfg. Co., Cockshutt Plow Co., A. R. Williams Machinery Co., Sawyer-Massey Co., Macdonald Thresher Co., A. R. Lumry, Robt. Bell Thresher Co., International Harvester Co., Goodison Thresher Co., Fairbanks-Morse Co., Delco-Light, Sampson Tractor Company, Cleveland Tractor Co., Kardell Tractor Co., DeLaval Separator Co., Bateman-Wilkinson, U. S. Tractor Co., Renfrew Mac. Co., Hoag Oil Engine, Massey-Harris Company, Automotive Corporation, Toledo, A. Hemme & Sons, S. Vessot & Co., Marsh Machinery Co., Kline Fanning Mill, Gould, Shapley & Muir Co., Ltd.

ductive capacity of steel in this country to-day must be fully 50,000,000 tons.

The movement of labor from the farms has become alarming. This will in time be corrected by the lessening of pressure for labor in manufacturing industries, but this will take time, and, meantime, food products are bound to remain high.

The one outstanding and controlling factor to-day—not only in this country but throughout the world—is the shortage of capital. This is due to three causes: the destruction of capital in the war; the tremendous expansion of industry as evidenced by the great outpouring of securities in the last few years, and, finally, by the absorption in taxes of profits that would otherwise be available for enlarging business facilities. The fact is being brought home that there is a vast difference between currency and capital; that inflating currency does not increase the supply of loanable capital. It seems to us that this shortage of capital, which, after all, is but a synonym for accumulated wages or savings, is bound to result in continued high rates, which of itself is a restrictive and deflating influence.

### MACHINERY AND THE FARM LABOR PROBLEM

(Continued from page 11)

some would have you believe. For the most part these farmers have either been unsuccessful or else they have made such a big success of farming that they can afford to retire, in which case the farm will be rented to a good tenant. In the former case, some neighboring farmer will either purchase or lease the abandoned farm and in so doing will have need for labor-saving equipment, such as a tractor, small thresher, etc., that he wouldn't require, perhaps, to operate his smaller former acreage holdings.

Instead of a calamity, the abandonment of small farms in many instances should be regarded as a blessing, both for the farmer, the implement dealer and the country at large. Small unit production can never be placed on the same economic production as large units for in the latter case equipment can be kept busy, working at maximum capacity. Bigger fields will result in a fuller utilization of labor and equipment and will bring about needs for larger farm machines—and the larger the machines, the greater the labor-saving value. For instance, no tractor would prove a paying investment in the small, checker-board fields of many of the farms in Eastern Canada, enclosed as they are by land-wasting, weed-breeding rail fences of the snake or zig-zag variety. A tractor would spend most of its time turning around in the corners instead of increasing agricultural production. But remove a few of these fences, combine several fields into one, and with tractor equipment the farmer could farm a bigger acreage, utilizing every foot of land, and do it at a smaller cost and with less labor than he is at present. And in the same way production, efficiency and economy can be effected by combining one or more small farms, putting the resulting larger farm on a business efficiency basis instead of the haphazard dabbling in agriculture that characterizes so many of our small farms. It's just like operating a big city industrial enterprise—the bigger the business, the smaller the overhead expense on the pro rata volume.

The implement dealer has a very definite place in bringing system and order out of near-chaos in localities where such conditions exist. If he will analyze the needs of the farmer who complains of a labor shortage, he can, no doubt, discover ways and means of helping that farmer by supplying him with labor-saving, production-increasing equipment. The world must have food and if sufficient farm labor cannot be found to produce it, then machinery must more and more take the place of labor.

### PREDICTS CONTINUED HIGH PRICES FOR FOOD PRODUCTS

IN their weekly business letter, Hayden, Stone & Co., investment brokers, New York, have the following to say regarding general conditions:—

Whether due to a change in the psychological atmosphere, owing to reports of cancellations and to reductions in price by large merchandise retailers, or to badly crippled transportation facilities or to both, it has now become quite evident that there is a distinct recession in many lines of business. While such an interruption to progress of business as has been occasioned by the outlaw railroad strike is most regrettable, it has also furnished a greatly needed object lesson, which could, perhaps, be supplied in no other way—that no body of men employed in such a vital industry can quit work without seriously affecting great numbers of other wage-earners. The fact is that the transportation system of this country is at the best so inadequate, and has been still further so crippled by the action of these men, that even were all other conditions favorable, this alone would make it impossible to continue business operations at anything like the volume necessary to show the best results. Nor is this a condition that, even if the roads generally could command the necessary capital, could be remedied in a week or a month. It would take years to supply the equipment necessary to put the railroads on a basis where they could adequately serve the business of the country.

The point has been well made that there has never been an instance of any serious financial depression when there has been such a general scarcity of goods, but the difficulty in securing goods, owing largely to transportation conditions, is apt to blind one to the fact that productive capacity is probably well up, and, perhaps, in some lines exceeds consumption. The pro-

*Aikenhead's*  
"The Sign of Better Service"

THE "SIOUX" BUSHING REMOVER



Solves the old time-wasting and patience-trying job of removing bushings.

Consider the time that has been spent needlessly in repair shops removing bushings with a punch or other unsatisfactory and tedious method. Many times you have charged such work at a loss because the actual cost would have seemed unreasonable to your customers. It is no longer necessary to waste time and lose money in this way. Bushings can now be removed in less time than it takes to tell about it—with the "Sioux" Bushing Remover. It greatly reduces the expense incident to the old method.

**Aikenhead Hardware Limited**  
TORONTO - CANADA



# Business Better Than Usual—

That's the slogan for 1920-21---adopted by all representatives of

## “HEXALL”

Trade Mark Reg. U. S. Pat. Office

### Socket Wrenches

**T**HERE will be no break in the demand for “HEXALL” Socket Wrenches. **You can bank on that!** In fact, all indications point to a continued, logical, healthy increase.

**It's your game as well as ours!** Do not be misled by the bleatings of calamity-howlers. Business is better than usual. **Do your part!**

Be prepared with complete lines of the **best socket wrenches in the world—“HEXALL”**—the name universally known and asked for—socket wrenches so dependable that this guarantee goes with every one—a challenge to makers and users alike:—

*“Break any Sedgley Wrench and We Repair it—No Charge”*

Handles are drop-forged; sockets made from bar steel on automatic machines; broached and case-hardened. Brute strength, unflinching dependability.

**There are seven sets---a “HEXALL” for every need!**

Let's continue to talk big business for 1920-21!

**R. F. SEDGLEY, Inc.** Est. 1897

Also Makers of “BABY” Hammerless Revolvers

2311-13-15 North 16th St., Philadelphia, Pa.

Canadian Distributors: Lamontagne, Limited, Montreal, Canada.

Sole Agent: Harold F. Watson Co., 208 Coristine Bldg., Montreal, Canada.



“HEXALL” Ratchet Socket Wrench No. 1—16 Pcs.

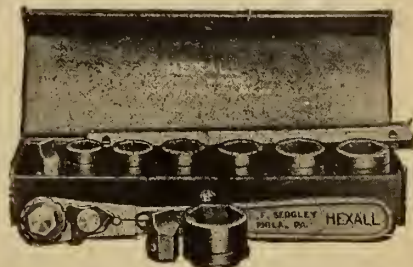

“HEXALL” Ratchet Socket Wrench No. 2—11 Pcs.



“HEXALL” Socket Wrench No. 5—8 Pcs.

# Unprecedented Demand for Automotive Equipment

**A De Luxe Combination Streamline Hood and Radiator Mask**



Adds wonderfully to the appearance, value and efficiency of any 1912 to 1916 Ford.

The patented De Luxe Streamline Hood and Radiator Mask is the most distinctive and exclusive outfit for Ford cars on the market. The front of radiator section is nicely pressed or rounded out, both top, sides and bottom.

The hood is perfectly plain on top, the sides being rather low, leaving the perfect streamline from dash to front of radiator. Sufficient louvers are made for ventilation.

No. 6422 — Price, for 1911-1914 Fords with flat dash. \$17.00  
No. 6423 — Price, for 1915-1916 Fords with cowl dash 17.00

The Automobile Industry is now regarded as the second largest on the continent. Therefore, dealers are optimistic regarding the future sales of Automotive Equipment. They report an unprecedented demand for Equipment and Supplies, especially of articles that cater to the welfare of car owners, by adding to the beauty of their cars, or to the comfort and convenience of automobiling.

## The HYSLOP Line

ensures the dealer unlimited business possibilities. This line has won the approval of the great bulk of Canadian car owners, because every item placed on the market represents Quality and Utmost Value in Service. Any dealer who keeps a well balanced Hyslop Line is sure to capture the business in his territory, besides receiving handsome profits and making permanent customers. Sell the Hyslop Line exclusively.

### Exhibition Message to Dealers :

See our display at the Hyslop Booth in the Automobile Accessory Building, August 28th to September 11th, 1920.

Your visit to the Toronto Exhibition will be incomplete unless you pay a visit to our headquarters. Here you will see the largest and most up-to-date building in Canada devoted to the sale and distribution of automotive equipment.

Our salesmen will be on hand to conduct you through our premises and you will observe at your leisure the magnitude of our stocks and the facilities for giving prompt attention to all orders for equipment and supplies.

**Adamson Foot Accelerator for Fords**

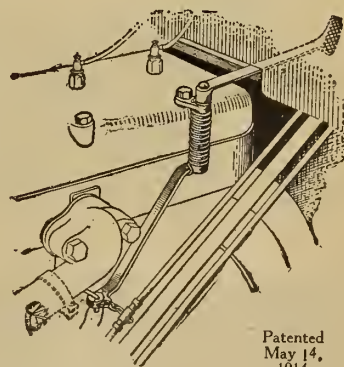

Patented May 14, 1914

A Practical Device, giving the operator complete control of the throttle with the foot. It operates entirely independent of the hand throttle. Same as that regularly used on all other cars and is of equal convenience to the Ford driver. No fitting or altering whatever is necessary, so simple anyone can install it.

No. 6447—Price.....\$2.00

**HYSLOP BROTHERS LIMITED, SHUTER AND VICTORIA STREETS Toronto, Ontario OPPOSITE MASSEY HALL**



# MALLEABLE CASTINGS for TRACTORS

The Pratt & Letchworth  
Co., Limited

General Sales Office:  
Transportation Building  
Montreal

## BIRDSELL CLOVER HULLERS

Best for Threshing,  
Hulling and  
Cleaning

Little Red or Common Clover Seed  
Big English or Mammoth Clover Seed  
Alsike Clover Seed  
Sweet Clover Seed



### THREE SIZES FOR CANADA

No.	Cylinders	Capacity	Power Required
No. 2	27" x 32"	3 to 5 bushels per hour	6 to 8 H. P.
No. 1	30" x 36"	5 to 7 bushels per hour	8 to 10 H. P.
No. 8	40" x 52"	7 to 10 bushels per hour	10 to 12 H. P.

WE HAVE A SIZE TO SUIT EVERY NEED

## ANN ARBOR HAY PRESSES

If in the market for a Hay Baler we can  
furnish in any size to meet your requirements.  
Write us or call and see us while in the city.

**Birdsell Manufacturing Co.**

Foot of George Street  
Toronto, Canada

## NEWS — OF THE TRADE FOR THE TRADE

### ONTARIO

**TORONTO.**—Manson Motors, Limited, has been incorporated with a capital stock of \$1,500,000.

**TORONTO.**—The East Washing Machine Company has been incorporated with a capitalization of \$400,000.

**ST. CATHARINES.**—Reece McKinley, pioneer wheel and spoke manufacturer, died recently aged 90 years.

**YARKER.**—A. W. Benjamin, head of the Benjamin Wheel Co., died recently.

**HAMILTON.**—The employees and staff of the International Harvester Company held their annual picnic recently at Wabasso.

**PEORIA.**—The Hart Grain Weigher Company has applied for permission to increase its capital stock from \$350,000 to \$1,100,000.

**FERGUS.**—Beatty Bros. Limited, have issued their new B. T. Barn Book which contains information on barn plans and equipment.

**MIDLAND.**—Incorporation is announced of the Glen Transportation Company, Limited, with a capitalization of \$500,000.

**PETROLIA.**—Orton Motor Company, Limited, is a new concern incorporated recently with a capitalization of \$500,000.

**HAMILTON.**—The Beaver Motor Truck Corporation Limited, has been incorporated with a capitalization of \$1,000,000.

**ST. CATHARINES.**—The St. Catharines Automobile Club is putting on a membership campaign and arranging to hold club runs to other cities.

**PETERBORO.**—J. G. Campazzie has resigned from the De Laval Company to become general sales manager of a Boston company engaged in manufacturing automobile parts.

**NEW HAMBURG.**—Simpson Meoner, who was for many years engaged in the manufacturing of agricultural implements, died recently at 71 years of age.

**OTTAWA.**—A return in the Commons shows the following importation of automobiles in 1918 and 1919: (1918) 16,848, \$15,022,400; (1919) 7,762, \$6,769,179.

**MORRISBURG.**—Harback & Barr, who were established this spring, are doing a good business in vulcanizing and general repairs. Their garage is 50x50 feet.

**BEAVERTON.**—Jeaston Badgerow, who for many years conducted an implement business in Beaverton and retired in 1907 to live in Toronto, died at his Toronto home on July 14.

**GALT.**—As the result of an explosion of a gasoline torch at Scriver's Garage recently, Master Cecil Scriver, son of the proprietor, and W. Laveny, an employee of the garage, are in the hospital suffering from severe burns.

**TORONTO.**—The incorporation is announced of the Cornfield Wheel Company, with an authorized capital of \$750,000. The new concern will manufacture and deal in motor and motor truck wheels.

**NORTH BAY.**—The name of the Nipissing Motor League has been changed to that of Northern Ontario Motor League. Thomas Wallace is president, E. W. Ross vice-president and T. Noble is secretary-treasurer.

**TORONTO.**—A branch office has been opened by the Elgin Gas Motor Company, manufacturers of the "Hafa-Hors" engine, and is in charge of Ike Woods from the Winnipeg branch.

**HAMILTON.**—The International Harvester Company, Hamilton, has in the Harvester Athletic Association a sporting organization of considerable importance. It has participated in Hamilton sport with much success.

**KITCHENER.**—Chief of Police O'Neil announced recently that, in accordance with an amendment to the traffic by-law by the City Council, parking cars along King street, the city's principal thoroughfare, would not be allowed.

**WELLAND.**—The Plymouth Cordage Co., of North Plymouth, Mass., and Welland are presenting a film story of their product from the cultivation of sisal hemp to the finished rope and binder twine.

**FORT WILLIAM.**—About 500 men, including members and non-members of the Twin Port Motor Club, at the instigation of the club agreed to help in one afternoon to improve a four mile stretch of road, leading to one of the best bathing beaches, which was in poor condition.

**WESTON.**—The Willys-Overland Motor Co. has purchased the buildings and four and a half acre site of the Roman Stone Company of Weston. It is understood the buildings, which contain 40,000 square feet, will be occupied by the Moline Plow Co., which is establishing a branch in Canada.

**WESTON.**—A new automobile company is being floated and the manufacturing plant will be situated in Weston district. The new company, it is understood, will manufacture its own car and will not be a subsidiary of an American concern. Weston people are being asked to buy stock.

**FALKENBURG.**—E. C. Hagerman, a salesman for the Goodyear Tire and Rubber Co., Toronto, was killed on July 27 when an automobile in which he was riding was struck by a train at Moore's Crossing, near Falkenburg. He was a native of Oakville and served in the British Navy during the war.

**BROCKVILLE.**—The shareholders of Canada Foundries and Forgings met in a special meeting recently to act upon a by-law by the directors authorizing the purchase of the business undertaking of the Mann Axe and Tool Company of St. Stephen, N. B., and the sale thereof to the Mann Axe Company Limited, of the same place.

**OTTAWA.**—On July 26 Keith Dwyer of Ottawa was sent to Guelph Prison Farm by Magistrate Askwith for a term of not less than one or more than two years for theft of his father's automobile. Dwyer took the automobile without permission on a joyride and wrecked it on Aylmer road. His father laid the charge against him. Dwyer is considered incorrigible.

**Oshawa.**—The General Motors Corporation has presented to the town through Mayor Stacey two cheques, one for \$3,000 and the other for \$6,000 and the deed for a 65-acre farm situated on the lake shore. The farm has to be converted into a park and the \$3,000 to be used in initial improvements. The \$6,000 is for the procuring and equipping of a park and play ground in the Southeast ward.



Sectional View of Case Air Washer

Note that the air is drawn downward through the water, passing through a fine submerged screen, which breaks up the bubbles; then upward through the water, washing out every particle of dust.

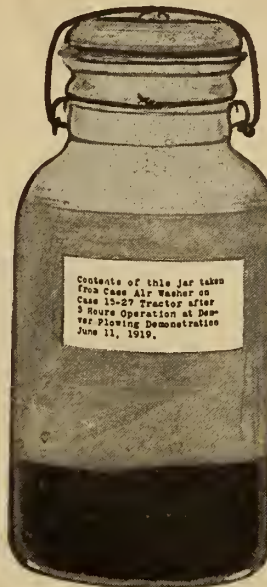
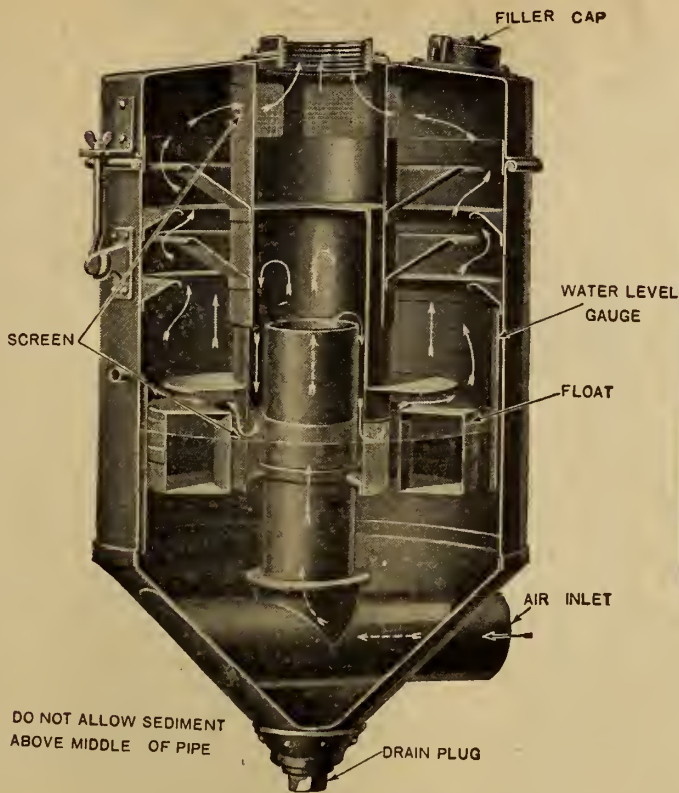

Look for the EAGLE Our Trade Mark

To avoid confusion, the J. I. CASE THRESHING MACHINE COMPANY desires to have it known that it is not now and never has been interested in, or in any way connected or affiliated with the J. I. Case Plow Works, or the Wallis Tractor Company, or the J. I. Case Plow Works Co.

The glass jar illustrated, approximately 1/2 gallon capacity, shows sediment removed from Case Air Washer after a 5 hour run.

## The Case Air Washer

### The "Dust-mask" That Protects Case Kerosene Tractors

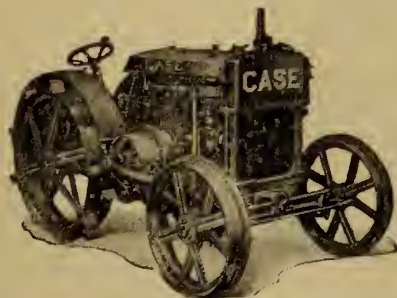

Case 10-18 Kerosene Tractor

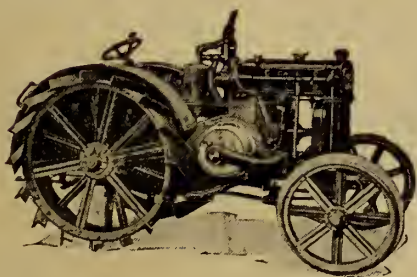

Case 15-27 Kerosene Tractor

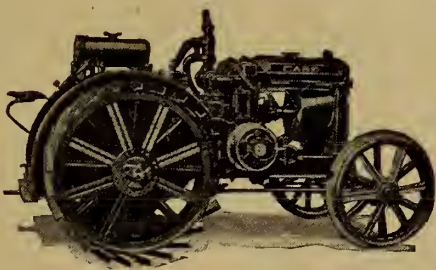

Case 22-40 Kerosene Tractor

DUST and grit are just as surely fatal to tractor cylinders and pistons as is poison gas to human lungs. Working in dusty fields, the unprotected tractor sucks in sand and grit which passes through the carburetor and into the cylinders. The result is scoring of cylinder walls and piston rings, causing loss of compression and power.

The Case Air Washer, shown in sectional view above, prevents dust or grit entering the cylinders of Case Kerosene Tractors. All air drawn into the motor by the suction of the pistons must pass through water and through a screen submerged in water. This removes every particle of dust and grit. It also moistens the air, thus increasing the efficiency of the motor.

The half-gallon jar illustrated above, shows the dust and grit collected by a Case Air Washer during a five hour run of a Case Kerosene Tractor in a dusty field. Just imagine the damage possible from working this grit through a tractor motor in five hours; then multiply that damage by every half-day the tractor works, and you will understand one of the many points of superiority of Case Kerosene Tractors. Write for catalog showing their other advantages.

**J. I. CASE THRESHING MACHINE CO., Inc.**  
Dept. O-8, 345-9 Dufferin St., Toronto, Ont.

Making Superior Farm Machinery Since 1842

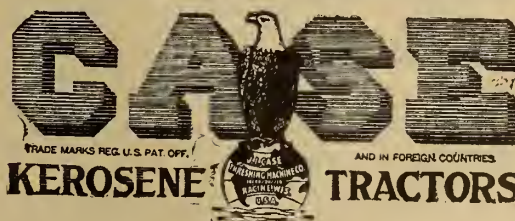



# Northern Electric

AUTOMOTIVE ~ EQUIPMENT

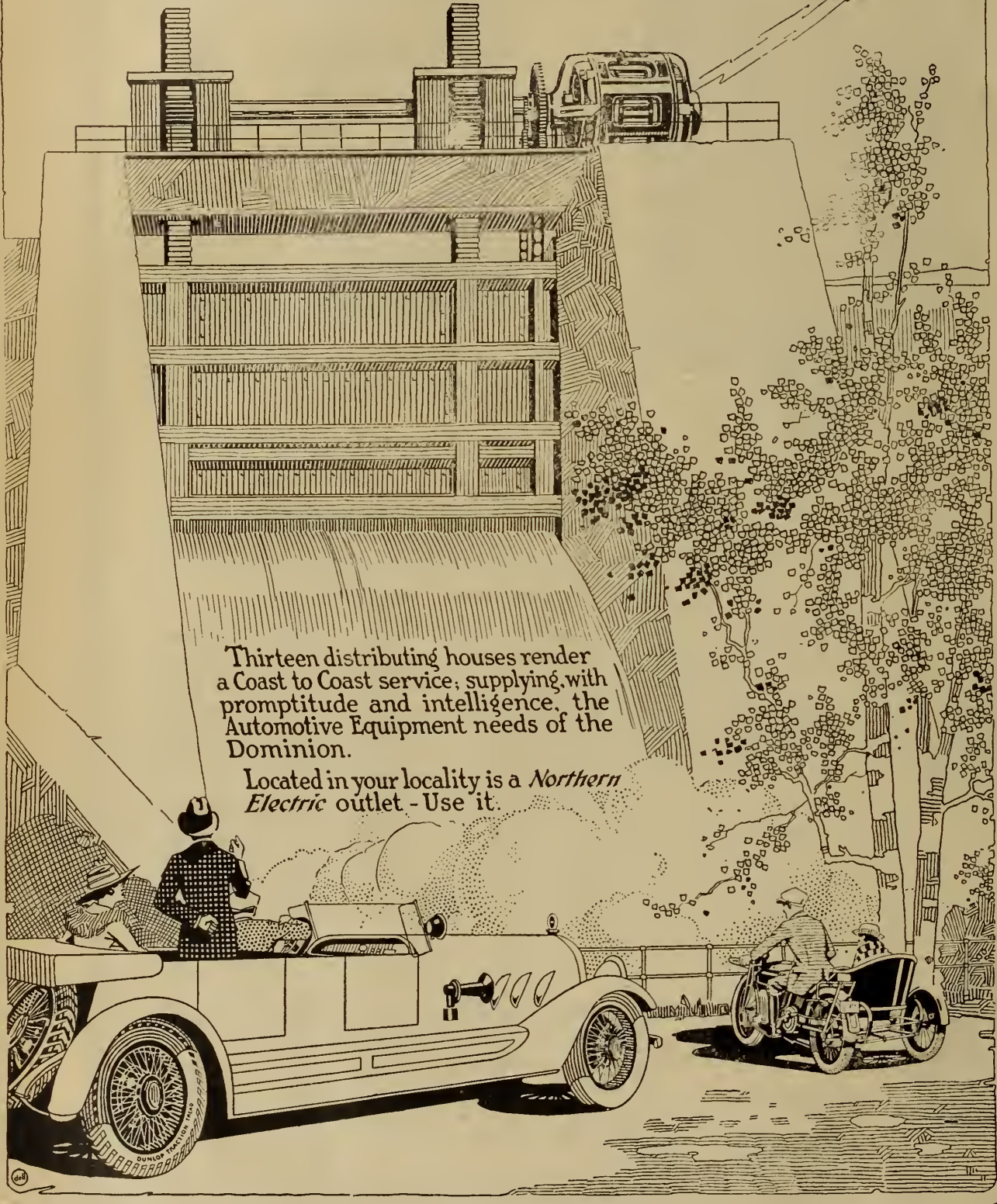

Thirteen distributing houses render a Coast to Coast service, supplying with promptitude and intelligence, the Automotive Equipment needs of the Dominion.

Located in your locality is a Northern Electric outlet - Use it.

## MAYBE ADAM LAUGHED AT THESE

**Humorous Artist:** "What's the matter? It's a good joke, isn't it?"  
**Editor:** "It's a very good joke. The first time I heard that joke I laughed till the tears rolled down my bib."

\* \* \*

**Hint to Speeders.**—First Constable—"Did yer git that feller's number?"  
Second Constable—"No, he was too gold-derned fast for me. Thet was a perty pert-lookin' gal in the back seat, wasn't it?"  
First Constable—"She shure was!"  
—*Hum Bug.*

\* \* \*

"You'll get run in," said the pedestrian to the cyclist, "if you ride without a light."  
"You'll get run into," responded the rider, as he knocked the other down.  
"You'll get run in, too," said the policeman, as he stepped forward and seized the cyclist.  
Just then another scorcher came along without a light, so the policeman was run into, too, and had to run in two.—*The Mirror.*

\* \* \*

**Gilfer.**—"What's the matter, Sandy? Aren't you going to play this afternoon?"  
Sandy—"Man, have you not heard? I've lost ma ball."—*Punch.*

\* \* \*

The Sunday School teacher was illustrating the Text: "Arise and take the young child and its mother, and flee into Egypt."  
Showing a picture, she asked: "Now isn't that splendid? Here is the mother, here is the young child, there's Egypt in the distance."  
One child looked disappointed and finally said: "Please, teacher, where's the flea?"

\* \* \*

**Dibbins.**—"I hear that your daughter married a struggling young man."  
**Jibbins.**—"Well, yes, he did struggle, but he couldn't get away."

\* \* \*

A Chink by the name of Ching Ling Fell off of a street car—bing! bing!—  
The con turned his head,  
To the passengers said:  
"The car's lost a washer"—ding ding!

\* \* \*

"We had raisin pie for dinner and pa got awful mad."  
"What's the matter? Doesn't he like raisin pie?"  
"Yep, but he told ma he'd bought those raisins for another purpose."

\* \* \*

**Small Girl** (to her little brother)—  
"Why can't yer enjoy yerself? Yer've seen two fights an' a naccident, an' been trod on by a Y. C. Yer wouldn't 'ave 'ad treats like them if the Germans 'ad won. Ungrateful little monkey."—*London Tid-Bits.*

\* \* \*

"What will you give me for this horse?"  
"A load of hay," replied the farmer.  
"What would I want with hay and no horse to eat it?"  
"Well, I'd be willing to lend you the horse till the hay was all gone."—*Boston Transcript.*

\* \* \*

Want ad. in the Wichita Falls Times: "For sale—a full-loaded cow, giving milk, three tons of hay, a lot of chickens and several stoves."

**AUTOMOBILE SPRINGS**  
The Guelph Spring and Axle Co.  
Guelph, - Ontario  
Manufacture  
**AUTO SPRINGS**  
ALL KINDS  
HIGHEST QUALITY

**SAYS THE MASTER MECHANIC:** The Greb Automatic Grip Puller is a One-Man Puller—Quick-acting, strong and simple in the extreme. May be locked in any desired position. A combination of two or three arms. Heavy Duty Size capacity 1" to 18"—Junior Size Capacity 1" to 7". Two sets of jaws furnished with each size.  
**TEN DAYS' TRIAL.**—If your dealer or jobber does not have them we will send you one. Try it ten days. If not satisfactory, return to us and we will refund your money. We also make the GREB RIM TOOL.  
THE GREB COMPANY, 319 State St., BOSTON

"What time next train go to Washington?" a travelling Chinese asked the railroad information clerk.  
"Two-two," replied the official.  
"You no understandee," insisted the Celestial. "I know the train go too-too. I no ask how he go; I ask when he go!"—*World Outlook.*

"Is you' husband much of a provider, Malindy?"  
"He jes' ain't nothin' else, ma'am. He gwine to git some new furniture providin' he gits de money; he gwine to git de money providin' he go to work; he go to work providin' de job suits him. I never see such a providin' man in aii mah days."—*N. D. News.*

\* \* \*

The highway was dark. The man felt his way along the wall toward his wife's room. A dim figure loomed up in front of him. Thinking it was the maid, he caught her to him and kissed her full on the lips. He waited. His wife's voice broke the silence!  
"Oh, Henry," she breathed.  
His name was John.



### HARVESTER COMPANY SECURES NEW SITE

THE International Motor Truck is to be put as soon as possible into greatly extended production. Harvester Company officials have just secured a site for the erection of the largest motor truck plant in the world to provide their truck with manufacturing facilities more in keeping with American and world demand.

The site of the new plant, which will be in addition to Akron Works, is situated at Fort Wayne, Indiana. The facilities for International Motor Truck manufacture and distribution were investigated of twenty-eight industrial centres in the United States before the Fort Wayne site was selected, in order to find the very best base for International Motor Truck extension. In a word, Fort Wayne was selected for its strategic situation with respect to the delivery of raw materials from the Company's mining and lumber and steel producing properties and from available sources of purchase and with respect to the quick and facile distribution of the finished product.

"Fort Wayne's position," says Cyrus McCormick Jr., works manager, "is favorable geographically and its railroads and their connections are the most completely supplied with that special equipment which is needed for delivering International motor trucks to the company's dealers and distributors the country over and to the 107 International Harvester branch houses in the United States and Canada. An arrangement has been made between the Harvester Company and the Fort Wayne Chamber of Commerce for the completion, as the first quota, of 1,000 new homes for International Harvester men and their families. These homes will not be concentrated in an industrial home centre, but will be distributed among a number of attractive suburbs. As a safety measure, all plans must be approved both by the company and the Fort Wayne organization which has the construction in charge. The homes will be sold to employees at actual cost plus ten per cent. on the amount of investment.

"It is a noteworthy fact that the site purchased for this great new plant comprises 140 acres of land and that this represents the greatest acreage for manufacturing purposes of any of the International Harvester plants on the American continent, of which this will be the 24th, or of the European plants of the Company, which are seven in number. Health and comfort of the workers and ease, efficiency and perfection of work will be the major ends involved. The machinery and equipment will follow the same principle and no expense or pains will be spared to equip the great plant for the happiest and most satisfied workmen and for making the best and most economical motor truck which can be built."

## Plowing time is testing time for Tractors

When harvesting operations have been completed the farmer enters on a busy season of plowing. This is the season when farm tractors are weighed in the balance, both in the farmer's mind and in his fields.

And the big fact they must prove is, strength and power to stand up under the strain of day-in-and-day-out operation on the heaviest job on the farm.



Dealers handling "Essex" Tractors should reap a rich harvest now. The farmer is at the height of his buying power, and he's up against a big job, and he needs help. "Essex" Tractors already placed on neighboring farms advertise the fact that "Essex" develops the power and has the strength of construction to do economically all the work claimed for it.

*If you are not an "Essex" Dealer ask us to tell you why you should be.*

**ESSEX TRACTOR CO., LIMITED, Essex, Ontario**



Tool Locked in Position  
for Removing or Replacing Tire  
**K.P. Universal  
Rim Tool**

**PRICE \$6.00**

Sold by

**Northern Electric  
Company, Limited**

Montreal Ottawa London Regina Edmonton Toronto Winnipeg Calgary Vancouver  
K. P. Products Company, Inc., 250 West 54th St., New York City

## A 24-Hour Radiator Repair Service



Why fuss with troublesome radiator repairs? They can be more cheaply and effectively executed by the manufacturer.

Ship any make to our Repair Department and in 24 hours, or less, it will be on its way back to you—freight or express as you instruct.

We promise you no wait service and A No. 1 workmanship.

**McCORD MFG. CO.**  
WALKERVILLE, ONTARIO



# Simplicity

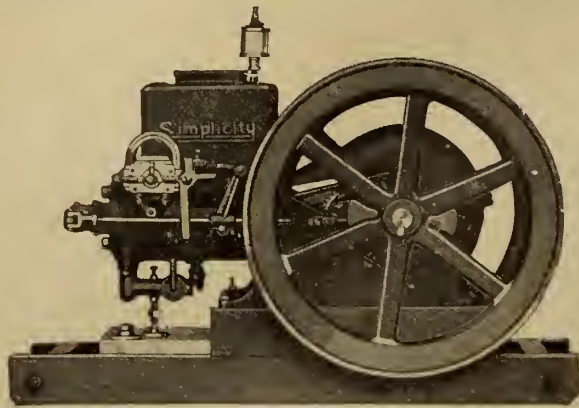

**T**HERE is a Simplicity Engine for every power purpose on the farm. No complicated parts to get out of order. The simple construction means freedom from trouble, long life and full power. Everything in full view. Easy to understand and to adjust.

## 9 Simplicity Features

*Simple Construction*—Easy to understand and operate. Free from trouble.

*Surplus Power* built into every Simplicity Engine.

*High Grade Material* used in every part.

*Absolute Safety*—All moving parts guarded.

*Smooth Running*—Fly wheels are carefully turned, trued and balanced.

*Built-in-Magneto* starts and operates the engine without batteries.

*Oil-Tight Crank Case* and guard prevents throwing and splashing of oil.

*Great Economy* owing to the simple and perfect working carburetor.

*Fully Guaranteed*—Every Simplicity Engine is backed by strong and liberal guarantee.

*Sizes*—Gasoline, 1½ to 16 H.P.; kerosene, 3 to 16 H.P.; stationary, skidded or portable.

*Send for Price List and Catalog*

**Turner Tractor Sales Co.**  
WINNIPEG, MAN.

**Power Farm Machinery Co.**  
EDMONTON, ALTA.

Turner Mfg. Co., 441 Lake St., Port Washington, Wis., U.S.A.  
Export Department, 44 Whitehall St., New York, N.Y.

## News of the Trade

### QUEBEC

QUEBEC.—The Canada Motors is the name of a new garage opened recently. F. J. Bambrooke is manager.

MONTREAL.—The incorporation is announced of the C. F. N. Gas Engine Company of Canada with a capitalization of \$100,000.

MONTREAL.—Dunn's Auto Makers, Limited, has been incorporated with a capital stock of \$1,000,000, with headquarters in Montreal.

ST. JOHN'S.—Four persons were injured, one probably fatally, recently, when an automobile containing five persons was struck by a freight train on the St. James street crossing at St. John's. The occupants were thrown out and landed some 25 feet away, the car being badly smashed.

### ALBERTA

TOFIELD.—G. Symington, a local implement dealer, has given up business.

LETHBRIDGE.—The fourteenth annual convention of the Western Canada Irrigation Association was held here on July 28, 29, and 30th.

CALGARY.—A Goodyear Truck Tire Service Station has been established in the Irving-McKillop Company's garage (formerly Webber's Garage). The most modern equipment in tire service has been installed in this, one of Canada's best garages.

### MANITOBA

WINNIPEG.—The Motorcycle police of Winnipeg are a nifty corps. They have practically chased the auto thief from the city.

PORTAGE LA PRAIRIE.—W. Umbach, western manager of the Waterloo Manufacturing Company, was married recently to Miss E. A. Cameron.

BRANDON.—The Townsley Manufacturing Co. has registered an application for permission to increase its capital stock from \$20,000 to \$60,000.

PORTAGE LA PRAIRIE.—An interested visitor to the provincial plowing match was K. N. Forbes, manager of the Winnipeg branch of the Canadian Fairbanks-Morse Company.

WINNIPEG.—A. C. McRae, implement and automobile dealer, died recently at the General Hospital, Winnipeg. Mr. McRae was one of the moving spirits in the establishment of the exhibition in Winnipeg and was for years an active member of the board.

### SASKATCHEWAN

WADENA.—O. Newman has purchased the implement business of W. H. Walker.

SASKATOON.—The incorporation of the Rodless End Gate Co., with authorized capital stated to be \$200,000, was recently announced.

REGINA.—H. H. Kohlman, assistant manager of the John Deere Plow Co., Regina Branch, has been appointed manager of the same branch.

INDIAN HEAD.—The McKenzie Thresher Co., Ltd., is doing a big business in all lines. The company is handling some second hand tractors.

REGINA.—The Provincial Exhibition was held from July 26 to 31. The attendance and attractions were bigger than ever.

REGINA.—W. Harrington, manager of the Regina office of the Canadian Oliver Chilled Plow Co. was a visitor at the head offices of that company recently.

HUMBOLDT.—Messrs. Kelly Bros. will erect a new garage and show room on Livingston street. The building will be two storeys and constructed of red brick and will cost in the neighborhood of \$25,000.

SASKATOON.—Four American army planes arrived in Saskatoon on July 26 after flying from New York against a 40-mile wind. They averaged 70 miles an hour and covered the distance in fifteen hours.

### BRITISH COLUMBIA

LUMSDEN.—Alexander Bros. have taken over the garage formerly occupied by T. B. Cook. They keep a stock of Ford parts and handle all repairs.

NEW WESTMINSTER.—Show rooms will shortly be opened by Owners Limited, at the corner of Columbia and Church Streets. They will handle Studebaker and Gray Dort cars.

VANCOUVER.—The directors of the Vancouver Automobile Club at a recent meeting decided to impose an entrance fee for new members of \$5, starting from June 1st, and to increase the membership fee to \$10 per year instead of \$5, as from January 1st, 1921.

### THE STORY OF A REMARKABLE SALESMAN

Continued from page 13

were in Chicago three days ahead of schedule time.

Something less than six months—a record-breaking achievement even under normal conditions!

This story really doesn't need to have its moral pointed out. Like the yellow-labelled almond bar, "it's chock-full of 'em."

The company is building cars and selling cars. The car is bringing a high price—and it's worth it!

Automobiles and tractors are more than just so much iron and steel. There's a certain indefinable element of humanness that they seem to absorb from the men who make and sell them. This has a real dollar-and-cents value, and you don't have to be a sentimentalist to recognize it either!

And again, it isn't so much a question of geography. Lots of these cars are being sold two thousand miles away from the factory. Some of them are going right back to the parts makers' own town!

No, sir! geography doesn't make a whole lot of difference. If this particular bird is a fair sample of the organization, they could build their stuff way down in the south end of the Fiji Islands and still attract a Detroit market!

It's a tribute that's paid to the man who gets things done; gets them done irrespective of conditions; gets them done without wasting time looking for obstacles!

It's easy to find excuses for not doing a job; it's darn hard to find reasons.

A peptomist looks for neither!! If there were no difficulties in the way of getting things done, lots of us, Corona and myself included, would be out of a job. And those who kept their jobs wouldn't get much satisfaction out of working.

After all, I guess there are plenty of opportunities for the man who can meet an emergency by changing the liability into an asset, by turning the obstacle into a constructive force.

It's being done, too. Yes, sir! it's being done every day, and the birds who are doing it are getting ahead!



# WESTERN NOTES

## NEW LAND MAP

A NEW edition of a map of Manitoba, Saskatchewan and Alberta giving the number of quarter-sections available for homestead entry in each township with the boundaries and offices of Government land agencies has been issued by the Natural Resources Intelligence Branch of the Department of the Interior. This new edition clearly indicates all railways, forest reserves, parks and Indian reserves, also the land which has been reserved for soldier settlement purposes. The size of the map is 24 in. by 36 in. and the scale 35 miles to one inch.

The importance of the new edition at the present time is apparent to prospective settlers, officials of banks, railway companies and land agencies, in fact everyone interested in the development of land in the Western provinces. A copy of this publication, which is known as the "Small Land Map of Manitoba, Saskatchewan and Alberta," may be obtained free of charge by applying to the Superintendent of the Natural Resources Intelligence Branch of the Department of the Interior, at Ottawa.

## FARMERS OWN MOST CARS IN SASKATCHEWAN

ACCORDING to J. Paxton, chief of the motor license department, Regina, 52,500 automobile licenses for the first six months were issued by the provincial secretary's department as against 50,575 issued during the corresponding period last year. The total number issued in 1919 was 54,816. These figures do not, however, accurately represent the number of motor vehicles owned in Saskatchewan as the law requires a new license to be issued whenever a car already in the province passes from one owner to another. Only 7,842 of the cars licensed by the branch last year were city owned, as follows: Regina, 2,629; Saskatoon, 2,228; Moose Jaw, 1,418; Swift Current, 429; Prince Albert, 377; Weyburn, 429; North Battleford, 332.

## TRACTOR PLOWING COMPETITION

THE annual Manitoba Provincial Plowing Match held at Portage la Prairie recently was largely attended and the farmers showed considerable interest in the tractor plowing events. The following tractors and outfits led in the various classes. All tractors used kerosene and were operated by the owners.

Class 5.—Bert Craig, driving a Fordson, 11-22 h.p. with a 2-furrow Hamilton plow. Score, 81 points.

Class 6.—L. Wishart, driving a Heider 10-18 h.p. tractor, with a 2-furrow Rock Island plow. Score, 84 points.

Class 7.—W. J. McCuaig, handling a Wallis 15-25 h.p. tractor with a 3-bottom J. I. Case Plow. Score 88 points.

Class 8.—J. W. Brydon, operating a Waterloo Boy, 12-25 h.p. pulling a 3-furrow John Deere Plow. Score 81½ points.

Class 9.—R. A. McDonald, operating an Imperial 15-30 h.p. tractor, pulling a 4-furrow Cockshutt plow.

## NEW BURD DEPOT

THE Dalzell-Beers Co., of Winnipeg, have opened a distributing depot for Burd high compression and Burd quick seating piston rings. B. E. Dalzell, formerly with the Wood-Valence Co., of Winnipeg, is in charge. They will open at Regina a distributing centre for Saskatchewan. A full stock of rings will be carried suitable for all makes of autos, trucks and tractors.

## DEFEAT GOVERNMENT ON LUXURY TAX

THE British Columbia Retail Merchants Association at their concluding session at New Westminster recently passed resolutions urging that the luxury tax be collected from the source of supply, manufacturers and importers. "Give me a little more time and we'll defeat the Government on this luxury tax," declared Dominion President Banfield during a lively discussion.

## DR. TOLMIE ISSUES WARNING

SPEAKING before the Canadian Club at Regina on July 26, Dr. Tolmie, Dominion Minister of Agriculture, according to a Canadian Press dispatch, declared that \$500,000,000, or one-fourth of Canada's national debt, could be added annually to the wealth of the country by adoption of more intelligent and enterprising methods of agriculture.

The one-crop system was doomed, said Dr. Tolmie, and mixed farming with stock raising as its basis, was destined to come into its own. While the acreage under crop in Canada had greatly increased during the last decade, there had been a marked falling off in the yield per acre.

"The whole tendency has been downhill," said Dr. Tolmie, "and more intelligence and enterprise on the part of the farmers would be required to stay this downward progress."

## TRACTORS IN THE WEST

CONSUL-GENERAL, J. I. Brittain, Winnipeg, has published reports indicating that 53 tractor manufacturers through their dealers sold tractors in Western Canada. In Manitoba, Saskatchewan and Alberta there were sold 8,844 tractors and during the same period, 104 steam traction engines. At present there are owned in the three provinces approximately 25,000 tractors; 7,500 were purchased in 1918 and about 5,000 in 1917. It is estimated that about 10,000 tractors will be sold during the year 1920. In 1919 there was invested in tractors about \$14,500,000, and there will be about \$17,500,000 invested in 1920. Generally speaking, the tractors sold comprise five classes. There was sold in 1919, as near as can be ascertained, the following of the various classes: 8 to 16 to 10 to 30 hp., 4,791; 14 to 25 to 16 to 30 hp., 2,011; 11 to 22 to 12 to 25 hp., 1,487; 17 to 34 to 20 to 40 hp., 374; 22 to 45 hp. and over, 181; steam traction engines, 104.

During the year 1919 one firm sold Manitoba, Saskatchewan and Alberta over 1,000 tractors.

## HOLD EXCURSION

THE Winnipeg Motor Industries' Social and Athletic Association recently held their annual basket picnic at Kenora Park. Sports and dancing contests were features of the occasion.

## WINNIPEG PARKING REGULATIONS

THE Winnipeg City Council will pass judgment soon on new parking regulations for down-town districts according to the Winnipeg Telegram. These regulations include time limits for parking of cars on the main thoroughfares, and the turning of boulevards on the streets adjoining Portage avenue into parking positions. The committee of works is considering taking over all boulevards on streets adjoining Portage avenue for a distance of one or two blocks. The curb stones would be removed and cars permitted to park nose-in to the edge of the sidewalks.

# Famous One Bolt Clamp on BT Steel Stalls

## Steel Stalls

No steel stall is stronger than the clamps. If the clamps break or slip, the stall is weakened at once. The patented one-bolt clamp on BT Stalls is made of malleable iron. It will not crack or break. It cannot slip because a solid ½ inch bolt goes right through both clamp and tubing. The clamp does not depend on friction. There is only one bolt to tighten.

Beatty Bros. Limited

Fergus, Ont.  
Montreal  
Vancouver  
London, Ont.

St. John  
Winnipeg  
Edmonton  
London, England

## You can sell anybody who needs a Feed Grinder

There are nine sizes of "Vessot" Feed Grinders—one for every grinding need—from the 6½ inch to the husky 15 inch Mill Type. No matter what demands a customer makes on his grinder, if you handle the

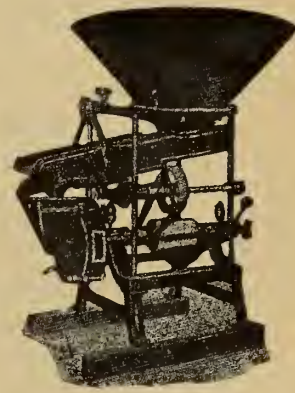

## "VESSOT"

Line you are able to give him just what he needs to get the most efficient service.

Remember "Vessot" Feed Grinders are the only ones equipped with the celebrated "Vessot" Grinding Plates, the cleanest cutting and most durable plates on the market. Genuine "Vessot" plates bear the trade-mark "S.V."

Any branch of the International Harvester Company will supply you with details of the liberal "Vessot" Agency Plan.

INVENTED AND MANUFACTURED BY

## S. Vessot & Co., Joliette, Quebec

Sold exclusively in Canada by

International Harvester Co. of Canada, Limited

Branches: Calgary, Edmonton, Lethbridge, North Battleford, Regina, Saskatoon, Yorkton, Brandon, Winnipeg, London, Hamilton, Ottawa, Montreal, Quebec, St. John.





# A Money Maker!

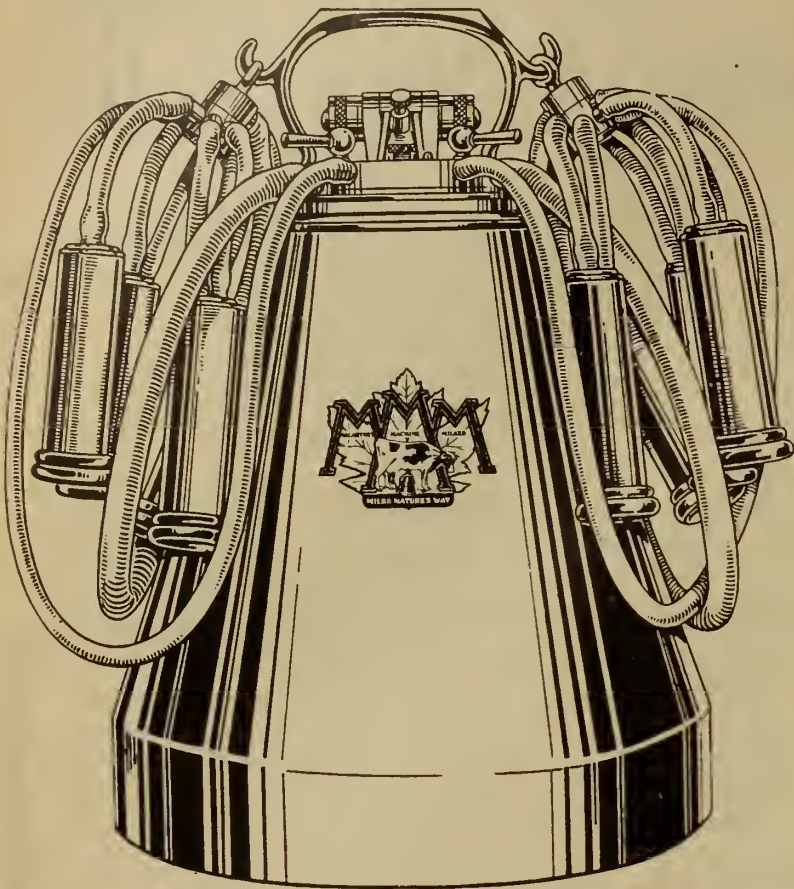

THE COW'S ADOPTED CHILD

Before you accept the agency for any particular milking machine, ask yourself "Which one will it pay me best to sell?"

The answer, after you've made the most searching investigation, is sure to be

## "The Macartney Machine Milker"

THE COW'S ADOPTED CHILD

Approved by the most successful dairymen and endorsed by the leading agricultural colleges, the Macartney Machine Milker is a labor-saver and a money-maker for the farmer or dairyman and a constant source of bigger profits for the Macartney agent.

Just think—one dealer made \$6,000 in five months with the Macartney Machine Milker! The agency proposition which made that record possible for him is awaiting you now. And back of you will be a campaign of consumer advertising, educating every farmer and dairyman in your locality to the advantages of the Macartney Machine Milker.

Anyhow it involves no obligation on your part to learn all about this proposition. But we advise prompt enquiry as territories are being closed up everywhere. So—write us to-day.

The  
**Macartney Milking Machine**  
**Co., Limited**

316 CATHERINE ST. - - - OTTAWA

## Dairy and Household Supplies

### MORE HOUSEHOLD DEVICES NEEDED

A SURVEY was recently undertaken by an official of the United States Department of Agriculture covering thirty-three states and 10,000 farm homes. The facts collected show that the average farm wife works over thirteen hours per day in summer and ten and one half hours in winter. Vacations are few and only about 13 per cent. enjoy them.

Nor are the conditions under which the farmers' wives carry on their daily household and outside toil greatly alleviated by labor saving devices. Nearly two-thirds depend on pumps or springs for water; only 60 per cent. have washing machines; but 20 per cent. have power in the house, although 43 per cent. of the farms reported on have power in the outbuildings; 79 per cent. still depend on oil lamps that must be cleaned daily; 80 per cent. are without that modern sanitary convenience, the bath tub supplied with running water, and 96 per cent. still have to make use of the outside closet.

While there has been no survey carried out in Canada it is safe to say that the Canadian farm wife is in much the same position as her American sister. The result of such conditions is that in the United States the women are showing the same reluctance as the men to staying on the farm and are migrating to the cities.

"The loss to family and community by such waste of woman power as the reports describe," concludes this suggestive survey, "could be prevented by a reasonable amount of planning and well-directed investment in modern equipment. Everywhere we hear of the economic importance of a contented rural population. Economists of our country, seeing the steady migration cityward, and recognizing the dearth of farm labor as a limiting factor in production, and connecting this with the isolation and inconvenience of rural living conditions, are pointing out that where these exist it is doubtful business policy to use increased income to buy more land with heavy interest charges against it rather than spend part of that income in raising the standards of living so that young people will not go to the cities in search of attractive living conditions and amusements."

The implement dealer should take his cue from this survey and go out after the household and dairy equipment end of his business.

The machines are needed and needed badly and it only requires an intelligent and persistent sales effort to place them. There is no question about the need for such devices as lighting systems, water systems, washing machines, carpet sweepers, cream separators, milking machines, etc., etc., it is purely a question of education.

Educate the farmer to the necessity, yes the urgent necessity of equipping his home as well as his farm with the modern conveniences. The catalogues and other sales help offered by the manufacturers coupled with personal letters emphasizing the fact that the farmer's wife is as much in need of mechanical help as the farmer himself and showing where time lost by old methods is money lost will help greatly to prepare the way for sales.

### A LATE DINNER, A HUNGRY FARMER AND A POWER WASHER

I HAD been busy all forenoon, so busy in fact, that I forgot about getting dinner until I noticed John coming from the field with the team. I left the old wash house and hurried to the kitchen. When I got there the fire

was out. I started the fire and was just putting dinner on the stove to cook when John came in, expecting to get his dinner at once, as he wanted to go to town after dinner to get some repairs.

I told him dinner was not ready, and what he said was "aplenty." When he finished I told him of a few things I could use to advantage, and one of them was a power washer. I said that if he could afford a car, manure spreader, hay loader and all those things, I could afford some of the things I wanted. He said he didn't know of any of the neighbor women having those conveniences. That's generally a man's excuse.

The question was dropped and I never expected that he would give it even a thought, but about a week later he came home from town with a new power washer, with wringer attached, with a small gasoline engine. We had a wash house 14x20 feet. Into this he put the washer and engine, connecting them by a line shaft.

The power washer was a decided success and reduced the hard work of washing to a minimum. We have since put running water, a drain and a stove to heat the water in the wash house. This saves unnecessary steps carrying water. I can now do my weekly washing in less than two hours, and it formerly took all day. A power washer certainly takes the hard work out of wash day.

The cost of operating is but a few cents an hour. The engine also runs the churn, separator, emery wheel grindstone and a small ripping saw; therefore the power cost for each unit is small.

Farmers of to-day are investing in labor-saving equipment as never before. The manure spreader, hay loader, tractor and numerous inventions are helping to make the farmer's work easier. Therefore I think the farmer's wife is entitled to a power washer, not a luxury, but a necessity. The time saved in a few months will pay for it. We find our power washer as efficient a labor-saving device as we have on the farm.—L. M. D. in *Farm and Home*.

### EMPIRE IN NEW OFFICE

THE Empire Cream Separator Company, who moved their executive offices to New York City pending the building of a new office home at the Bloomfield, N.J. plant, are now occupying the new building, which will be both the head office and the factory headquarters as well.

### LOCATION OF SILO

AN important consideration in selling silos is to see that a suitable location is secured when installing. If the silo is convenient for filling and feeding, the farmer is more likely to be satisfied with his purchase. If the silo is located outside, a position south of the farm buildings is to be prepared because of the reduction in freezing danger.

Provision should be made for locating the filling outfit and for ease in reaching with the teams hauling the corn. It is also important that the silo should be so placed that a chute can be easily constructed through which the ensilage can be dropped near the manger of the cattle. In other words the whole plan should be so arranged that the entire operations of filling and feeding can be carried on with the least possible inconvenience and expenditure of labor.



**Do not sign  
an "up-hill"  
contract**



## DE LAVAL SEPARATORS ARE EASIER TO SELL

De Laval Cream Separators are easiest and most profitable to sell, for several reasons: First, mechanical superiority—the De Laval is the closest skimmer, is easiest to turn and to wash, and lasts longest. Second, service rendered — the manufacturers always render prompt and intelligent service. Third, prestige—the De Laval is the best-known cream separator in the world; there are more of them in use than all other makes combined. Fourth, it is constantly advertised in farm papers and by direct-to-the-farm folders and letters. Fifth, there is a De Laval salesman conveniently located in every dairy community, ready to help De Laval dealers.

**This is easy  
sledding**

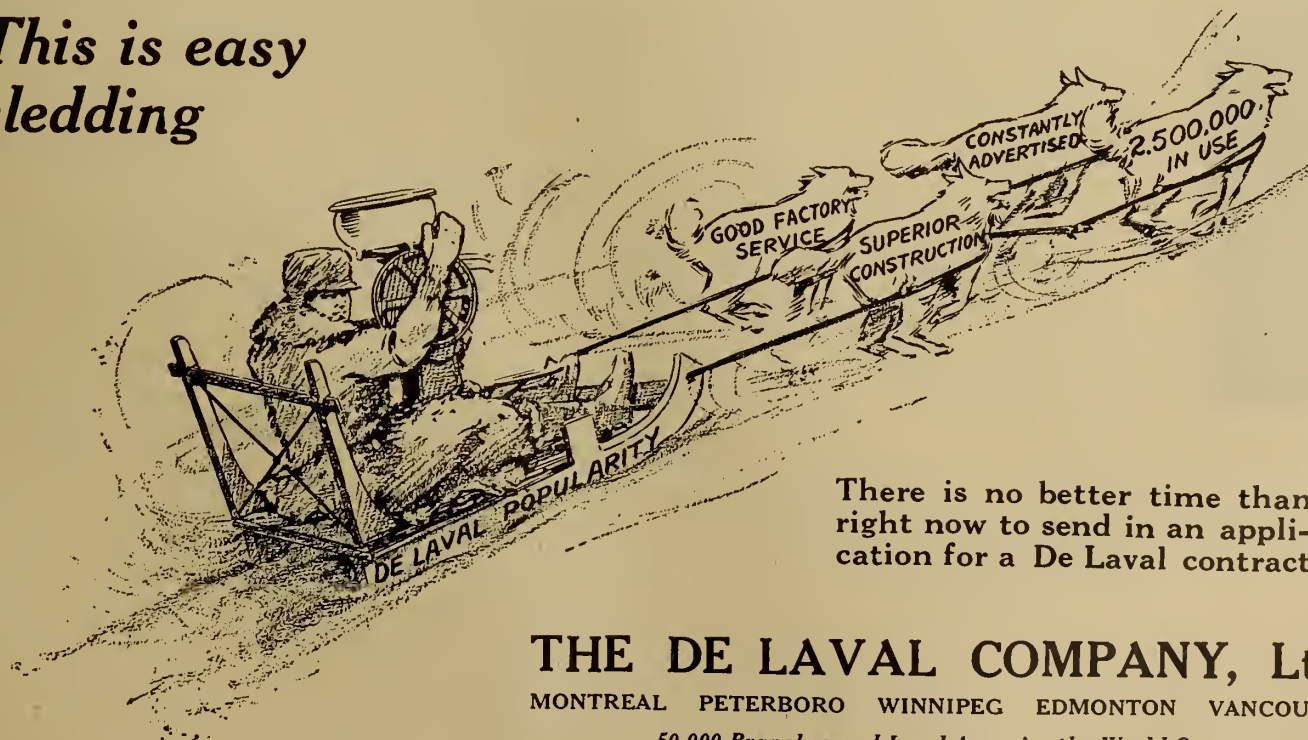

There is no better time than  
right now to send in an appli-  
cation for a De Laval contract

**THE DE LAVAL COMPANY, Ltd.**

MONTREAL PETERBORO WINNIPEG EDMONTON VANCOUVER

*50,000 Branches and Local Agencies the World Over*



# The Call

for the

## OK CANADIAN POTATO DIGGER

this season should find every dealer prepared.

OK CANADIAN DIGGERS have been solving the digging problems of the potato growers for the past ten years, and their record of satisfactory service stands dominant over all others.

The OK line is a seller. It has been, and is being, advertised extensively all over the Dominion, and every year is creating a bigger demand.

*Our selling proposition and literature will interest all dealers.*

### Canadian Potato Machinery Co.

59 Stone Road Limited  
Galt, Ont.

Makers of the OK Canadian Planters, Diggers, Sprayers, two-row and four-row, and the OK-Spra, and the OK Canadian Aylmer Sprayer.

### Sell Holton Hood Clips for Chevrolets



They stop hood rattles  
They do away with the  
troublesome thumb screw.  
They sell at sight. Every  
Chevrolet owner is a prospect.

Quickly adjusted without  
the use of tools. Engine  
hood can be opened and  
closed in a second or two.  
Holton Hood Clips Never  
Slip. A real spring clip.

**Your Jobber Stocks Them**

Patented and Manufactured by

**The Holton Hood Clip Co.**  
WINDSOR, ONTARIO

#### IF YOU SHOULD DIE!—

NO matter how vigorous your health may be, no matter how prosperous your business may be, some morning your friends will wake to the disagreeable duty of attending your funeral in the afternoon.

Have you ever stopped to consider what would happen to you, your family and your business, if you were to drop off tonight? If everything is not in satisfactory shape, the time to begin putting your affairs in order is now for the sake of good business alone.

Are you prepared to die? Not from a religious, but from a business, standpoint.

Stop and think a moment just what would happen in your store tomorrow if before night you should be assassinated by the bomb of an anarchist or drop lifeless walking along the street. If your business and family affairs are complicated, have you protected your wife and your children by a will?

Have you a trained assistant in the shop who knows the details of your business and has the ability to keep things going as they are for at least a few weeks, or until they can be properly adjusted?

Have you confided any business or professional secrets you may have to your wife, your son or a trusted friend, so that they may continue to exist as an asset?

Have you safeguarded your credit so that those who are left will not be worried and hounded and find it impossible to get new supplies?

These are but a few things of the many questions that will occur to the business man who will put his affairs in such condition that they will be proof against almost anything that can happen.—*Merchants' Journal and Commerce.*

#### GIVE TRACTOR DEMONSTRATION

COOK BROS., implement dealers of Hensall, Ontario, gave a tractor plowing demonstration on J. P. Row's farm, Zurich, Ont., recently. The farmers who witnessed the demonstration were favorably impressed. Cook Bros. received a car load of seven tractors recently and have sold them all but one.

#### K. & S. TIRE AND RUBBER

THE directors of the K. and S. Tire and Rubber Goods recently declared a dividend at the rate of 1¼ per cent. on preferred stock payable on July 15 to shareholders of record June 30. This company some time ago was incorporated to take over the K. and S. Canadian Tire and Rubber Company. There has been a steadily growing demand for this company's products.

#### COCKSHUTT TO ERECT NEW WAREHOUSE

THE Cockshutt Plow Co., Ltd., who for the past four years have had their offices over the C. N. R. Telegraph office in Edmonton, are erecting a two-storey brick building with a full concrete basement on 9,909,102 A. on Rice street, opposite the city market square. The building will be fifty feet wide and eighty-five feet long. The main floor will be used as a display room, while the second floor will be used entirely for offices, from which all of the company's work for central and northern Alberta will be directed. Manager Fred Pickles says that business in the machine line this year is better than ever, and that the prospects for the future are better than at any time during the five years that the company have their offices located here. With a display room in the centre of the city he expects that they will be able to more efficiently handle the local trade.

#### WILL CONDUCT "SAFETY SCHOOL"

THE Ontario Safety League will conduct a "School of Safety Instruction," for persons employed in industries in Toronto. The classes will meet fortnightly and from twelve to fifteen lectures will be given by experts on each subject up for consideration. The lectures will cover such subjects as: Design and Construction of Safeguards; What the Foreman Can do to Promote Safety; Electrical Hazards; First Aid; Eye Protection; Plant Sanitation, and so on.

#### BEATTY BROS. EXTEND FACTORIES

IN addition to large extensions to their factories in London, Ont., Beatty Bros. Limited, manufacturers of stable equipment, churns, washers, ladders, etc., are making extensive additions and improvements to their factories in Fergus, Ont. The installation of the Sidman Patent Dry Kiln, for drying green lumber in from eight to ten days, is now complete.

Large additions to their stable equipment factory in Fergus are now nearing completion. By August 1st, they hope to have an additional floor space of nearly three acres at their main Fergus factory alone. The additions are being built with pressed brick fronts, steel sash and prism glass.

The extra space is necessary to handle the greatly increased demand for the company's products. Some idea of the expansion may be gathered from the fact that the new shipping room alone will measure 144 ft. by 144 ft.

#### WILL DISCUSS FARM LABOR

THE Hyatt Roller Bearing Company announces that the next five or six issues of their publication, "The Tractor Tract," will be devoted to a discussion of the farm labor problem.

Much data has been collected through their close contact with the field. The subject will be treated from a constructive viewpoint and concrete suggestions will be submitted.

#### COLUMBUS GETS TRACTOR SHOW

THE Sixth Annual Tractor Show, which will be held at Columbus, Ohio, February 7th to 12th inclusive, in the permanent brick buildings at the Ohio State Fair Grounds, will be an educational and service rather than a sales show, and the arrangement and design of exhibits as well as the supplemental educational program are being planned with the idea of selling the farmers of the Central and Eastern States the general idea of power farming, upon as nearly as possible the right basis.

With this idea in view companies that have not proved their product and are not fully organized for production, sales and service will not be admitted as exhibitors. The farmers of the territory will be protected, so far as is possible by the show management, from exploitation by individuals and companies who are interested only in obtaining the farmers' money and who have no interest in what they get in return.

An educational program is being worked out and the best agricultural authorities in the country will be called in to assist in putting on this program. The show management feels that the honest, authoritative statements of these men will go far to counteract the careless, misinformed statements which too frequently have been made by men whose only object has been to make sales.

At this show all the latest, worthwhile developments in the power farm equipment line will be shown. All the space in the eight brick buildings, including the Coliseum, will be used for exhibit and lecture purposes. These buildings lend themselves readily to pleasing decorative effects and are easily lighted and ventilated. Special heating equipment will be installed and fuel oil will be used for fuel instead of coal or gas. The show management guarantees not only an attractive and pleasing show but one that will be comfortable in the coldest weather.

Every effort is being made that this show shall have an especial appeal to the farmer and be of real value to him. The primary object is to interest the farmer in the use of power on the farm and to do this intelligently and conservatively.

#### NEW CREAM SEPARATOR

ACCORDING to the U. S. Vice-Consul of Stockholm a Swedish company has been organized to manufacture an improved and cheaper cream separator. The inventor is E. G. Salenim. In the bowl is a corrugated block of porous pottery, in the centre of which is a conductor pipe through which air is blown. The milk is blown into a froth, the cream forming in drops on top of the skim milk. There are two openings at the upper part of the bowl, the higher one for cream, the lower one for skim milk. It is said that the capital stock of the company will be not less than \$2,044,000 and that American capital is interested.

#### COCKSHUTT EXPANDS

THE Adams Wagon Company, Limited, of Brantford, a subsidiary of the Cockshutt Plow Company, Limited, Brantford, Ontario, have secured the plant of the Petrolia Wagon Works, Petrolia, Ontario, and are fitting it up especially for the manufacture of sleighs and trucks. The plant is now in operation and will be working to capacity in a month's time. The present plant of the Adams Wagon Company at Brantford was not equal to the demand for its products and this new arrangement will enable the Brantford plant to devote its capacity to the production of farm wagons, dump wagons, drays, etc.

Contract has been let for an important addition to the plant of the Cockshutt Plow Company, Limited, Brantford, Ontario. An extension 200 ft. by 70 ft. is to be built to their forge department immediately and will give them additional capacity in this department, the necessity for which has been felt for some time.



### A TRACTOR THAT WALKS LIKE A HORSE

A NEW type of tractor that has recently been developed has a series of legs and walks like a horse. The machine is of the six-cylinder type but has no clutch. There are four crankshafts, each having a set of four legs, giving the tractor sixteen legs on which it walks. In addition there are four wheels automatically operated by the tractor engine, so that they can be lowered to the roadbed, thus converting the machine into a motor truck.

The feet are shod to conform to the ground conditions. A sharp chisel foot may be used to penetrate the soil to any desired depth, breaking up the plowpan and cupping it, allowing the moisture to settle into the cuppings, thus making it possible to produce larger crops; or a foot like that of a horse may be used on hard ground and in mowing grass or harvesting grain, or a foot may be used which is especially designed for soft, muddy ground.

The walking or propelling legs may be used to break up or puncture the subsoil to a greater or less degree, according to the work performed and the nature of the crop, or may be adjusted to take care of the proper pitch or working angles to suit different soil conditions, or adapted to side-hill work.

When the propelling legs are used for puncturing or breaking up the subsoil it aerates and fertilizes the subsoil and forms moisture-holding or retaining pockets, enabling a full crop of vegetation to be obtained with a greatly reduced rainfall.

When the machine is being used as a truck the propelling legs are raised clear from obstructions; but when it is found necessary to obtain great traction, these legs may be easily lowered and used in conjunction with the wheels, thus giving the machine a great advantage on muddy roads or in climbing hills. The machine will plow, seed, cultivate, harrow, mow and harvest, rake, furnish power for other machinery as a tractor and power plant and will also act as a truck for road work and heavy hauling. — *Scientific American*.

### WANTS CANADIAN AND AMERICAN TRACTORS

ACCORDING to a United States Commerce Report Britain is a greedy market for American motor tractors and automobiles. In the Leeds district the trade demand was phenomenal in 1919. The report says:

Prices during the year had a rising tendency, owing to increased cost of freight, labor, insurance, and the rate of exchange. At the end of 1919 the prices asked for American motor vehicles in Yorkshire had increased from 15 to 20 per cent. as compared with the early part of the year, and those asked at the beginning of 1920 are at least 100 per cent. higher than the pre-war prices. The price of petrol also increased during 1919 and is now 3s. 6d. (85 cents) a gallon; the cost of lubricating oils also increased considerably. Prospects in 1920 for trade in American cars are excellent, as deliveries are rapidly improving.

### INJECTOR COMPANY CHANGES HANDS

THE A. J. Wood Mfg. Co., of Grand Rapids, Mich., has been purchased by the Bennett Injector Company, of Muskegon, Michigan. For the past few years the A. J. Wood Mfg. Co., has been manufacturing the Wood grease injector.

Thomas B. Bennett, formerly of the Koebel-Bennett Auto Supply Company, Muskegon, is president and general manager.

### KOHLER EXPANDS

THE Kohler Co., Kohler, Wis., manufacturers of motor-generator units for farm lighting and power plants, will erect a brick and steel addition, 105x300 feet, to furnish additional factory space for the manufacture of their products.

# FARM IMPLEMENTS THAT SELL THEMSELVES

No matter in what district you live, Massey-Harris Implements are known to every farmer. They need no introduction. They are known for their dependable quality, sterling worth, and soundness of construction. Their good qualities have won the confidence and goodwill of all who use them.

The year round they make it easy to win a livelihood from the soil. Plowing, seeding, mowing, reaping, harvesting and marketing are done with complete satisfaction by means of Massey-Harris Implements.

When a man needs a new machine, past experience with Massey-Harris Implements will guide him to choose another of the same line. Every Massey-Harris machine in use helps to sell another bearing the same name.

Address all applications for representation in vacant territories to the manager of the branch nearest you.

## MASSEY-HARRIS CO., LIMITED

Head Office - Toronto, Ont.

Branches at: Montreal Moncton Winnipeg Regina Saskatoon  
Swift Current Yorkton Calgary Edmonton

### Good Position Open

One of Canada's largest and most aggressive manufacturing organizations desires to engage a representative between the ages of twenty-eight to thirty-five to extend present connections in special lines for the automotive industry; to introduce and develop special lines offering sufficient volume to justify mass production. Mechanical ability desirable but not imperative. The opportunities are unlimited for one with the necessary executive ability and initiative. Apply with full particulars of age, experience, and salary required to Box 100, Motor, Tractor and Implement Journal, 143 University Ave., Toronto, Ontario.

WE GIVE

## "Quality and Service"

IN

## TRACTOR and TRUCK STEEL CASTINGS

### Joliette Castings & Forgings Limited

Head Office :  
Transportation Bldg., Montreal

Works :  
Joliette, Que.



# VETERAN

## MOTOR TRUCKS

*Built in Canada*

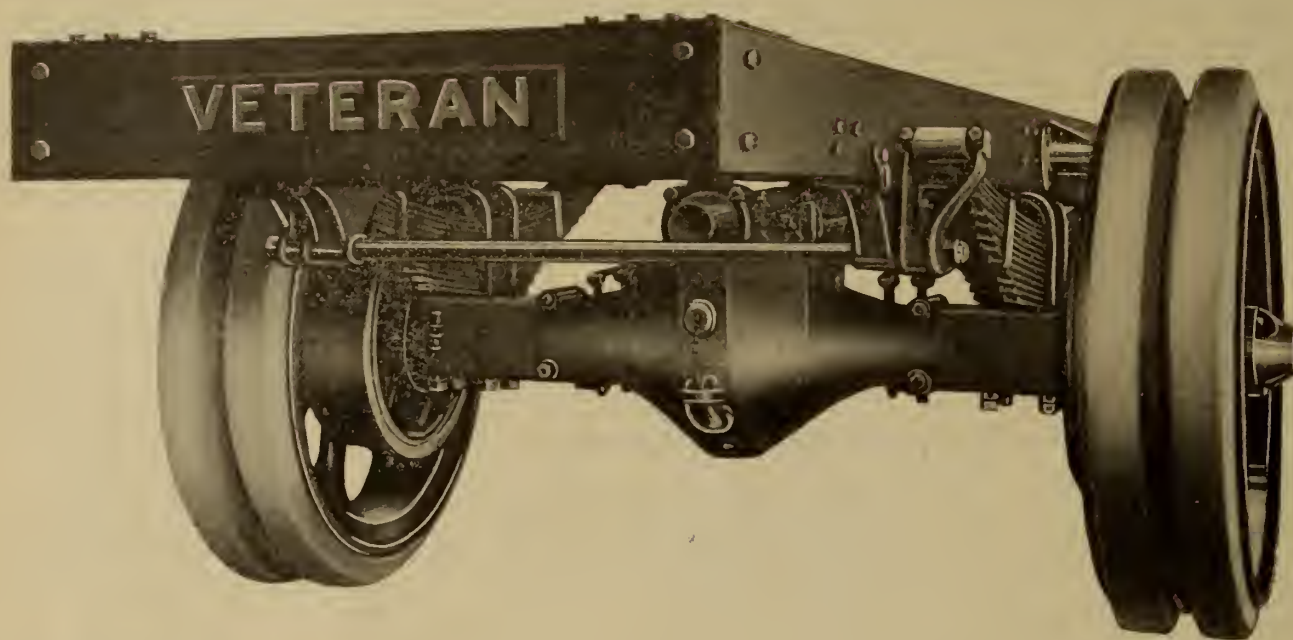

*The  
Best  
Truck  
Buy  
In  
Canada  
To-day*

A truck built in the States with essentials similar to those used in the Veteran will cost you from \$1000.00 to \$1200.00 more.

*A Line to the Factory or Our Distributors Will Bring You Full Details.*

Distributors for Western Ontario, Manitoba, Saskatchewan, Alberta and British Columbia.  
Commercial Cars Limited, Toronto, London, Winnipeg, Vancouver.

**EASTERN CANADA MOTOR TRUCK CO.**  
Limited  
HULL, - QUEBEC



# ANNOUNCING THE SAMSON TRACTOR

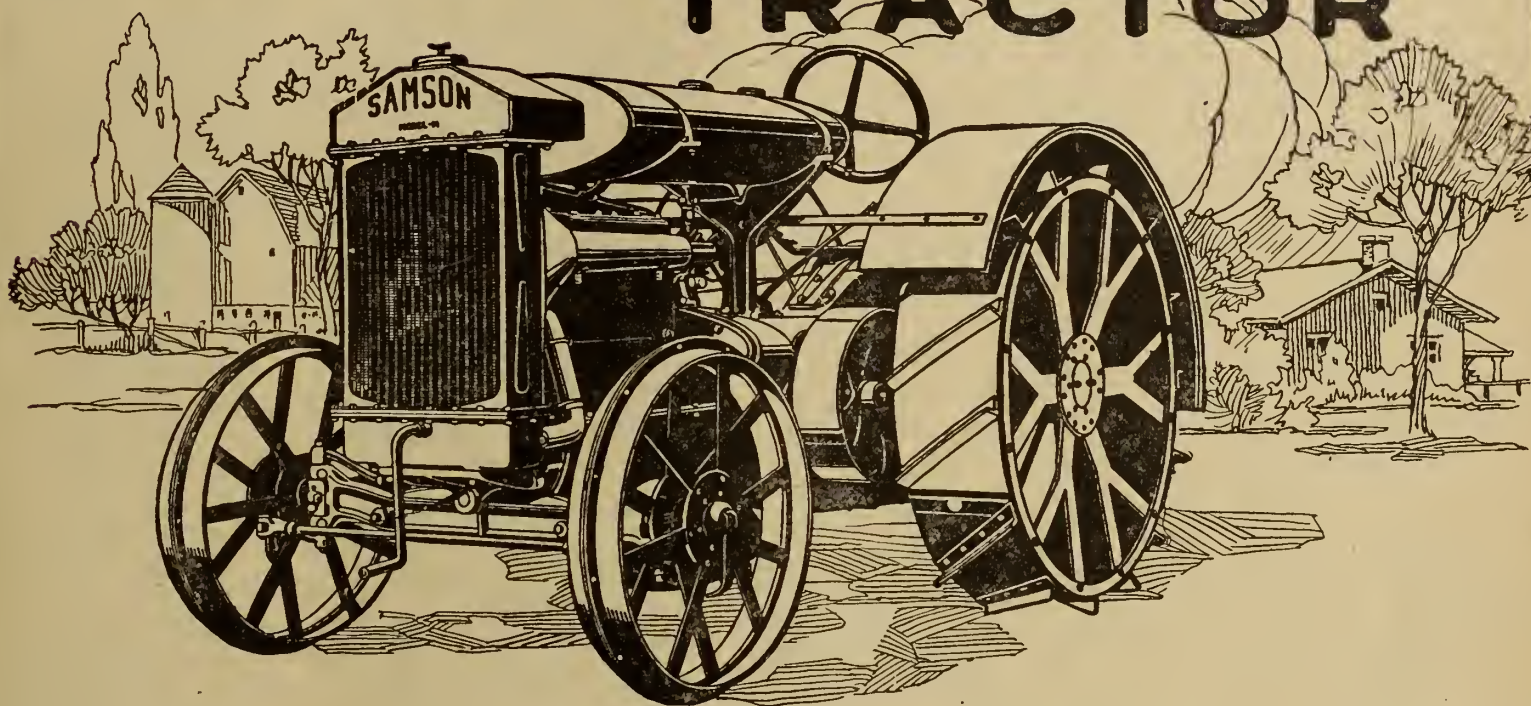

## WHAT THE SAMSON DOES

### DRAW BAR

- will pull a two or three bottom plow.
- will pull a tandem disc harrow
- will pull two 20-ft. spike-tooth harrows.
- will pull two four-horse grain drills.
- will pull two 7 ft. binders
- will pull large road grader or do any other heavy-duty draw-bar job.

### BELT POWER

- will handle any heavy-duty belt-power job.
- will run a 22 to 24 inch grain separator
- will run a 4 to 6 hole corn sheller.
- will run a heavy buzz saw.
- will run a heavy-duty grinder or ensilage cutter up to 14"
- will run a centrifugal water pump for irrigation purposes.
- will handle stone crusher or large concrete mixer
- will handle large hay balers, and, in fact will do any belt-power job requiring steady, reliable power within the range of the machine from morning till night.

## POWER FARMING WITH THE SAMSON

The Samson Tractor is a product of General Motors, makers of such well known cars as the McLaughlin, Cadillac, Chevrolet, Oldsmobile, G. M. C. Trucks, etc.

The Samson is the last word in modern down-to-the-minute Tractor construction—a close coupled power unit from radiator to rear wheels.

The Samson will take the place of a barn full of horses. It has no lost motion for it is built and lubricated like a high-priced automobile. The even distribution of weight, compact unit design, and low center of gravity give the Samson great stability, making it hug the ground and preventing all danger of rearing up and tipping over.

The Samson Model "M" is the one tractor you should look at before you buy a Tractor of any make or kind.

*The Samson line includes Tractors, Farm Implements, Motor Trucks and every device for power farming.*

*The Samson Model "M" will be at the Toronto Exhibition.*

*Write for Literature.*

*Live Dealers write or wire for open territory.*

**THE SAMSON TRACTOR CO. OF CANADA, LIMITED**  
SUBSIDIARY OF GENERAL MOTORS OF CANADA, LIMITED  
OSHAWA, CANADA



# CANADIAN Motor Tractor and Implement Trade Journal BUYERS DIRECTORY

This directory will help you with your buying and your planning. The advertisers listed here are thoroughly reliable and leaders in their respective fields. They are looking for live, wide-awake representatives. Study their advertisements carefully because they contain valuable information which will dovetail with your plans. We are glad to go to the trouble of arranging this list—to make it easy for you to select new lines. If it so happens that what you want is not here, write us, and we will tell you where to get it.

## ACCESSORIES

Advance Machine & Welding Co., Montreal.  
Champion Spark Plug Co., Windsor, Ont.  
Guelph Spring & Axle Co., Guelph.  
Holton Hood Clip Co., Windsor, Ont.  
Northern Electric Co., Ltd., Montreal.  
The Goodyear Tire & Rubber Co. of Canada, Ltd., Toronto.  
Apollo Plug Mfg. Co., Birmingham, Eng.  
R. F. Sedgley, Inc., Philadelphia, Pa.  
Can. Fairbanks-Morse Co., Ltd., Montreal.  
McCord Mfg. Co., Walkerville, Ont.  
Kinzing Bruce Co., Niagara Falls, O.  
The Greb Co., Boston.  
Aikenhead Hardware Co., Toronto.  
Hyslop Bros., Toronto.  
K. P. Products Co., 250 West 54th St., New York City.  
Perfex Radiator Co., Racine, Wis.

## AUTOMOBILE BUMPERS

Kinzing Bruce & Co., Ltd., Niagara Falls, Ont.

## AUTOMOBILE CHAINS

## AUTOMOBILE JACKS

Kinzing Bruce & Co., Ltd., Niagara Falls, Ont.  
Can. Fairbanks-Morse Co., Ltd., Montreal.

## BARN EQUIPMENT

Beatty Bros., Ltd., Fergus, Ont.

## BEAN MACHINERY

John Deere Mfg. Co., Welland, Ont.

## BEEF MACHINERY

International Harvester Co., of Can., Ltd., Hamilton, Ont.  
John Deere Mfg. Co., Welland, Ont.

## BINDERS

The Frost & Wood Co., Ltd., Smiths Falls, Ont.  
International Harvester Co., of Can., Ltd., Hamilton, Ont.  
Massey-Harris Co., Toronto.

## BELTING

## BATTERIES

Can. Fairbanks-Morse Co., Ltd., Montreal.

## CARRIAGES

Cockshutt Plow Co., Brantford, Ont.

## CREAM SEPARATORS

De Laval Co., Ltd., Peterboro, Ont.  
International Harvester Co., of Can., Ltd., Hamilton, Ont.  
R. A. Lister Co. (Canada), Ltd., Toronto

## CEMENT MIXERS

Can. Fairbanks-Morse Co., Ltd., Montreal.

## CASTINGS

Joliette Castings & Forgings Ltd., Montreal and Joliette, Que.

## CORN HARVESTERS

Cockshutt Plow Co., Brantford, Ont.  
International Harvester Co., of Can., Ltd., Hamilton, Ont.  
Massey-Harris Co., Toronto.

## CORN MACHINERY

International Harvester Co., of Can., Ltd., Hamilton, Ont.  
John Deere Mfg. Co., Welland, Ont.

## CULTIVATORS

Cockshutt Plow Co., Brantford, Ont.  
John Deere Mfg. Co., Welland, Ont.  
Massey-Harris Co., Toronto.  
The Frost & Wood Co., Ltd., Smiths Falls, Ont.  
International Harvester Co., of Can., Ltd., Hamilton, Ont.

## CUTTERS

Butterfield & Co., Inc., Rock Island, Q.

## DAIRY SUPPLIES

International Harvester Co., of Can., Ltd., Hamilton, Ont.  
R. A. Lister Co. (Canada), Ltd., Toronto  
DeLaval Dairy Supply Co., Peterboro.  
Swedish Separator Co., Montreal, Que.

## DIES

Butterfield & Co., Inc., Rock Island, Q.

## DISCS

Massey-Harris Co., Toronto.

## DITCHING MACHINES

Can. Fairbanks-Morse Co., Ltd., Montreal.

## DRILLS

Massey-Harris Co., Toronto.

## DRILLS, TWIST

Butterfield & Co., Inc., Rock Island, Q.

## DRILLS, GRAIN

Cockshutt Plow Co., Brantford, Ont.  
International Harvester Co., of Can., Ltd., Hamilton, Ont.  
John Deere Mfg. Co., Welland, Ont.  
The Frost & Wood Co., Ltd., Smiths Falls, Ont.

## ELECTRICAL EQUIPMENT

Westco Pump Ltd., Toronto.

## ENGINES

Can. Fairbanks-Morse Co., Ltd., Montreal.  
Gilson Mfg. Co., Ltd., Guelph, Ont.  
International Harvester Co., of Can., Ltd., Hamilton, Ont.  
John Deere Mfg. Co., Welland, Ont.  
The Frost & Wood Co., Ltd., Smiths Falls, Ont.  
Massey-Harris Co., Toronto.  
R. A. Lister Co. (Canada), Ltd., Toronto  
Renfrew Mchy. Co., Renfrew, Ont.  
The Turner Mfg. Co., Port Washington, Wis.

## ENSILAGE CUTTERS

Can. Fairbanks-Morse Co., Ltd., Montreal.  
Gilson Mfg. Co., Guelph, Ont.  
International Harvester Co., of Can., Ltd., Hamilton, Ont.  
Massey-Harris Co., Toronto.

## FEEDERS

John Deere Mfg. Co., Welland, Ont.

## FARM MACHINERY

Can. Fairbanks-Morse Co., Ltd., Montreal.  
Cockshutt Plow Co., Brantford, Ont.  
John Deere Mfg. Co., Welland, Ont.  
International Harvester Co., of Can., Ltd., Hamilton, Ont.  
Massey-Harris Co., Toronto.  
The Frost & Wood Co., Ltd., Smiths Falls, Ont.  
R. A. Lister Co. (Canada), Ltd., Toronto  
Gilson Engine Co., Guelph, Ont.

## FEED CUTTERS

Can. Fairbanks-Morse Co., Ltd., Montreal.  
Massey-Harris Co., Toronto.  
Gilson Engine Co., Guelph, Ont.

## GREASE CUPS

The Specialties Co., Montreal.

## GRINDSTONES

S. Vessot & Co., Joliette, P.Q.

## GRINDERS

Can. Fairbanks-Morse Co., Ltd., Montreal.  
International Harvester Co., of Can., Ltd., Hamilton, Ont.  
Massey-Harris Co., Toronto.  
R. A. Lister Co. (Canada), Ltd., Toronto  
S. Vessot & Co., Joliette, P.Q.  
Gilson Engine Co., Guelph, Ont.

## HARROWS

Cockshutt Plow Co., Brantford, Ont.  
International Harvester Co., of Can., Ltd., Hamilton, Ont.  
John Deere Mfg. Co., Welland, Ont.  
Massey-Harris Co., Toronto.  
The Frost & Wood Co., Ltd., Smiths Falls, Ont.

## HAY LOADERS

International Harvester Co., of Can., Ltd., Hamilton, Ont.  
John Deere Mfg. Co., Welland, Ont.  
The Frost & Wood Co., Ltd., Smiths Falls, Ont.

## HARDWARE

Can. Fairbanks-Morse Co., Ltd., Montreal.  
Massey-Harris Co., Toronto.

## HAY RAKES

John Deere Mfg. Co., Welland, Ont.  
The Frost & Wood Co., Ltd., Smiths Falls, Ont.

## HAY CARRIERS

Beatty Bros., Ltd., Fergus, Ont.  
Massey-Harris Co., Toronto.

## HAY PRESSES

Birdsell Mfg. Co., Toronto.  
International Harvester Co., of Can., Ltd., Hamilton, Ont.

## HULLERS (Clover)

Birdsell Mfg. Co., Toronto.

## LIGHTNING SYSTEMS

Can. Fairbanks-Morse Co., Ltd., Montreal.

R. A. Lister Co. (Canada), Ltd., Toronto

Northern Electric Co., Ltd., Montreal.

Gilson Engine Co., Guelph, Ont.

## LIME AND FERTILIZER SOWERS

John Deere Mfg. Co., Welland, Ont.

## LUBRICANTS

Imperial Oil Co., Toronto.

## MACHINE TOOLS

Windsor Machine and Tool Works, Windsor, Ont.

## MANURE CARRIERS

Beatty Bros., Ltd., Fergus, Ont.

## MANURE SPREADERS

Cockshutt Plow Co., Brantford, Ont.

International Harvester Co., of Can., Ltd., Hamilton, Ont.

John Deere Mfg. Co., Welland, Ont.

Massey-Harris Co., Toronto.

The Frost & Wood Co., Ltd., Smiths Falls, Ont.

Gilson Engine Co., Guelph, Ont.

## MARINE FITTINGS

Northern Electric Co., Ltd., Montreal.

## MOWERS

Cockshutt Plow Co., Brantford, Ont.

International Harvester Co., of Can., Ltd., Hamilton, Ont.

Massey-Harris Co., Toronto.

The Frost & Wood Co., Ltd., Smiths Falls, Ont.

## MOTOR HORNS (Electric)

Apollo Mfg. Co., Birmingham, Eng.

## MILKING MACHINES

R. A. Lister Co. (Canada), Ltd., Toronto

The Macartney Milking Machine Co., Ltd., Ottawa, Ont.

## MILLING CUTTERS

Butterfield & Co., Inc., Rock Island, Q.

## OILS

Imperial Oil Co., Toronto.

## PISTON RINGS

Lamontagne Ltd., Montreal, Que.

## PLOWS

Cockshutt Plow Co., Brantford, Ont.

John Deere Mfg. Co., Welland, Ont.

The Frost & Wood Co., Ltd., Smiths Falls, Ont.

International Harvester Co., of Can., Ltd., Hamilton, Ont.

Massey-Harris Co., Toronto.

## POLICE AND FIRE ALARM EQUIPMENT

Northern Electric Co., Ltd., Montreal.

## POWER AND LIGHT EQUIPMENT

Northern Electric Co., Ltd., Montreal.

R. A. Lister Co. of Canada, Ltd., Toronto.

## POWER MACHINERY

Can. Fairbanks-Morse Co., Ltd., Montreal.

John Deere Mfg. Co., Welland, Ont.

Massey-Harris Co., Toronto.

International Harvester Co., of Can., Ltd., Hamilton, Ont.

Gilson Engine Co., Guelph, Ont.

Renfrew Mchy. Co., Renfrew, Ont.

## POWER SWITCHBOARDS

Northern Electric Co., Ltd., Montreal.

## POTATO MACHINERY

John Deere Mfg. Co., Welland, Ont.

Cockshutt Plow Co., Brantford, Ont.

Can. Potato Mchy. Co., Galt, Ont.

## PULVERIZERS

Cockshutt Plow Co., Brantford, Ont.

International Harvester Co., of Can., Ltd., Hamilton, Ont.

## PULPERS

Cockshutt Plow Co., Brantford, Ont.

## RAKES

International Harvester Co., of Can., Ltd., Hamilton, Ont.

The Frost & Wood Co., Ltd., Smiths Falls, Ont.

## REAPERS

International Harvester Co., of Can., Ltd., Hamilton, Ont.

The Frost & Wood Co., Ltd., Smiths Falls, Ont.

## REAMERS

Butterfield & Co., Inc., Rock Island, Q.

## ROLLERS

Cockshutt Plow Co., Brantford, Ont.

Massey-Harris Co., Toronto.

Hyatt Roller Bearing Co., Chicago.

## ROLLER BEARINGS

Hyatt Roller Bearing Co., Chicago.

## SAW MILL OUTFITS

Massey-Harris Co., Toronto.

## SCUFFLERS

Cockshutt Plow Co., Brantford, Ont.

International Harvester Co., of Can., Ltd., Hamilton, Ont.

John Deere Mfg. Co., Welland, Ont.

## SEEDERS

Massey-Harris Co., Toronto.

## SCALES

Renfrew Mchy. Co., Renfrew, Ont.

Can. Fairbanks-Morse Co., Montreal.

## SCREW PLATES

Butterfield & Co., Inc., Rock Island, Q.

## STABLE EQUIPMENT

Beatty Bros., Ltd., Fergus, Ont.

## SILOS

Gilson Mfg. Co., Guelph, Ont.

## SLEIGHS

Cockshutt Plow Co., Brantford, Ont.

International Harvester Co., of Can., Ltd., Hamilton, Ont.

## SILO FILLERS

Gilson Mfg. Co., Guelph, Ont.

International Harvester Co., of Can., Ltd., Hamilton, Ont.

## SOCKET WRENCHES

R. F. Sedgley, Inc., Philadelphia, Pa.

## SEPARATORS (CREAM)

Swedish Separator Co., Montreal, Que.

## SPREADERS, MANURE

Cockshutt Plow Co., Brantford, Ont.

John Deere Mfg. Co., Welland, Ont.

International Harvester Co., of Can., Ltd., Hamilton, Ont.

Massey-Harris Co., Toronto.

Gilson Mfg. Co., Guelph, Ont.

## SPARK PLUGS

Machine & Stamping Co., Toronto.

Champion Spark Plug Co., Windsor, O.

Apollo Plug Mfg. Co., Birmingham, Eng.

## SPARK PLUG CLEANERS

Champion Spark Plug Co., Windsor, O.

## TELEPHONE APPARATUS

Northern Electric Co., Ltd., Montreal.

## TRACTORS

R. A. Lister Co. (Canada), Ltd., Toronto

Essex Tractor Co., Essex, Ont.

Gilson Mfg. Co., Guelph, Ont.

International Harvester Co., of Can., Ltd., Hamilton, Ont.

J. I. Case Threshing Machine Co., Inc., Racine, Wis.

Sampson Tractor Co. of Canada, Oshawa, Ont.

Massey-Harris Co., Toronto.

Renfrew Mchy. Co., Renfrew, Ont.

The Turner Mfg. Co., Port Washington, Wis.

## TRACTOR PLOWS

Cockshutt Plow Co., Brantford, Ont.

International Harvester Co., of Can., Ltd., Hamilton, Ont.

John Deere Mfg. Co., Welland, Ont.

Massey-Harris Co., Toronto.

## TIRES

## THRESHERS

Can. Fairbanks-Morse Co., Ltd., Montreal.

International Harvester Co., of Can., Ltd., Hamilton, Ont.

J. I. Case Threshing Machine Co., Inc., Racine, Wis.

R. A. Lister Co. (Canada), Ltd., Toronto

Gilson Mfg. Co., Guelph, Ont.

## THREAD CUTTING TAPS

Butterfield & Co., Inc., Rock Island, Q.

## TWIST DRILLS

Butterfield & Co., Inc., Rock Island, Q.

## TRUCKS

Motor Car Distributors Ltd., Montreal.

Beaver Truck Builders, Ltd., Hamilton

Eastern Canada Motor Truck Co., Ltd., Hull, P.Q.

International Harvester Co., of Can., Ltd., Hamilton, Ont.

## WHEELBARROWS

Cockshutt Plow Co., Brantford, Ont.

Massey-Harris Co., Toronto.

## WAGONS

Cockshutt Plow Co., Brantford, Ont.

International Harvester Co., of Can., Ltd., Hamilton, Ont.



# BUTTERFIELD

If you could look into a "Butterfield" tool room to-day you would see a number of skilled tool-makers very much absorbed in their different tasks. And noting the infinite care with which each one did his work, the painstaking attention to each slight detail, and the unconscious attitude of pride in the finished job, you would get one of the big reasons why Butterfield drills, taps, dies, reamers and milling cutters cut cleaner and last longer than ordinary tools.

"Butterfield" workmen are proud of their part in providing you with honest, long-lived tools.

And their pride is justified by results.

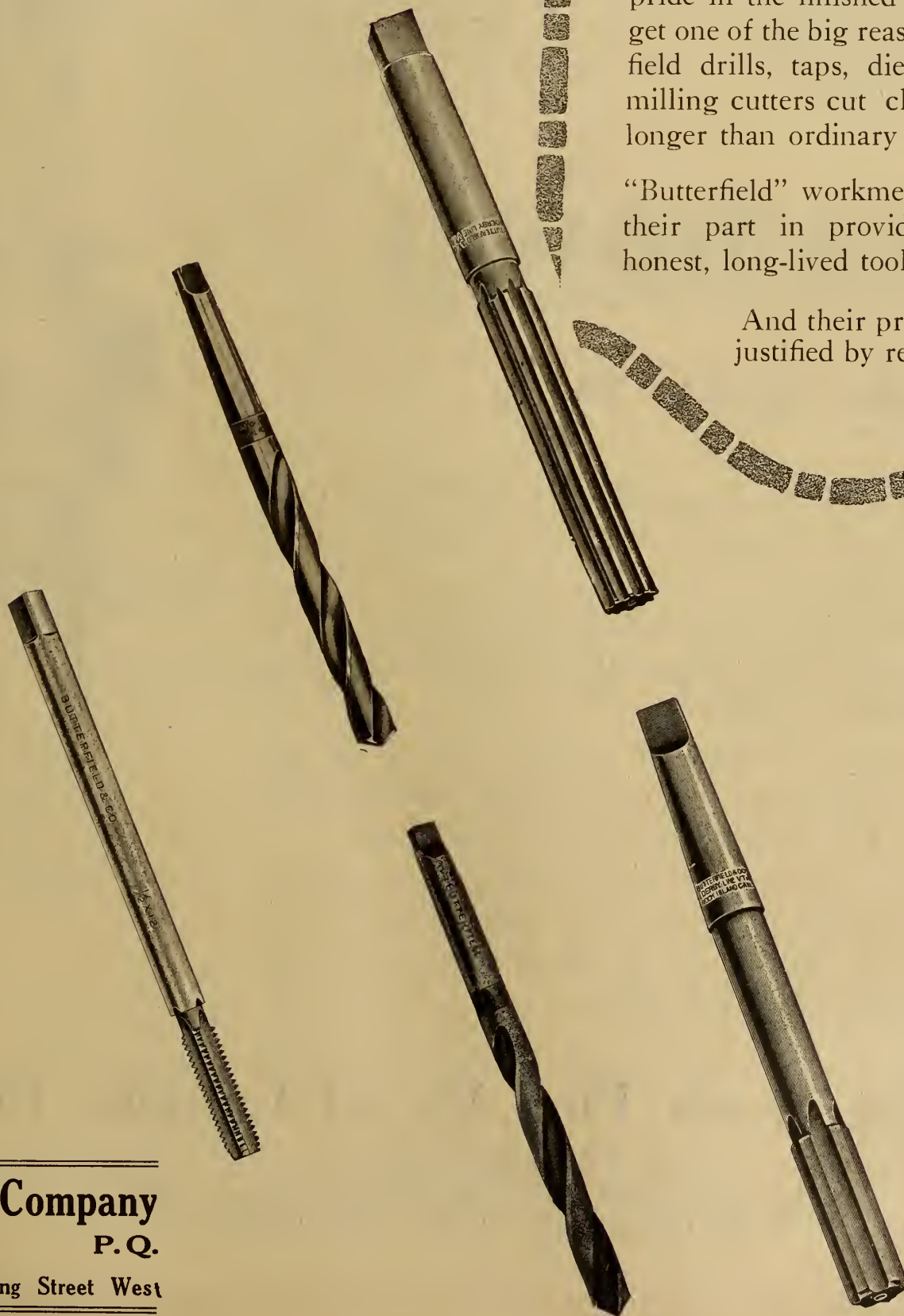

**Butterfield & Company**

Rock Island P.Q.

Toronto Office: 220 King Street West



# The Quickest Selling Spark Plug

To-day Spark Plug users don't hesitate when buying plugs. They say "Champion" from habit.

They know that "Champion" on the insulator of a spark plug is their assurance of absolute dependability, efficient service, satisfaction and economy.

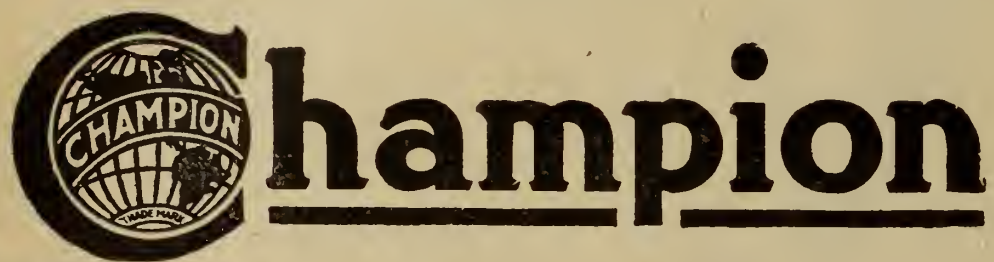

## Dependable Spark Plugs

have an unfailing dependability that has made them the most popular spark plug for every type of motor or engine.

Our Dominion-wide selling campaign has created a demand that makes them the quickest selling spark plug on the market.

There's bigger business waiting for you if you feature Champions, for they bring customers to your store for other dependable motor goods.

See that your stock of Champions is complete. There's a special plug for every type of motor. If you haven't a full stock on hand, order what you need from your jobber to-day.



CHAMPION A A 53  
7/8 inch, 18 long. Price \$1.00.

For use in McLaughlin Cars,  
Tractors, Trucks and Stationary Engines.

## Champion Spark Plug Co. of Canada, Limited

Windsor, Ontario

*Largest factory in Canada making Spark Plugs exclusively  
and the only factory making "Champions."*





# Beaver Trucks

*"Built For Business"*

**Built in Canada's Largest  
Exclusive Truck Factory**

**UNQUESTIONABLY  
"CANADA'S LOWEST HAULING COST"**

Some open territory still available—Catalogues and further information furnished responsible dealers upon request.

**Beaver Truck Builders, Limited**  
HAMILTON, ONTARIO



# IMPLEMENT DEALERS:

If you are not selling motor trucks you are overlooking an important source of added profit. The sale of motor trucks is a natural step for implement dealers keen enough to sense the tremendous demand for motor transportation now just beginning among farmers.

For implement dealers who have built up a solid business by selling reliable machines to farmers, Jumbo Motor Trucks offer an unusual opportunity to expand that business safely and surely---you can sell Jumbo Trucks to your customers and be certain that every sale is an additional asset, the source of repeat orders and increased good reputation. Jumbo users are, without exception, satisfied customers.

## These Jumbo Features Lower Sales-Resistance

The construction and equipment features listed below help sell Jumbo Trucks to farmers. Those features are responsible for the performance that has enabled many owners to run their Jumbo Trucks 20,000 to 30,000 miles without replacing a single part.

Powerful Buda Motor, Eisemann Magneto, Clark Internal Gear Axle---these are some of the units which are used in Jumbo Trucks, nothing but the very best combined in a design which gets the most efficient use from every part.

Every piece of equipment that makes efficient, comfortable operation is *standard* on Jumbo Trucks. Steel cab with three-man seat, heavy cushions, foredoors, sliding sash curtains opening with doors, Alemite pressure lubricating system (no grease cups), electric lights, motometer, hub odometer and many other features.

*Investigate the possibilities in the sale of motor trucks. The Jumbo sales plan has proved a business-getter for other dealers. Write to-day for full details.*

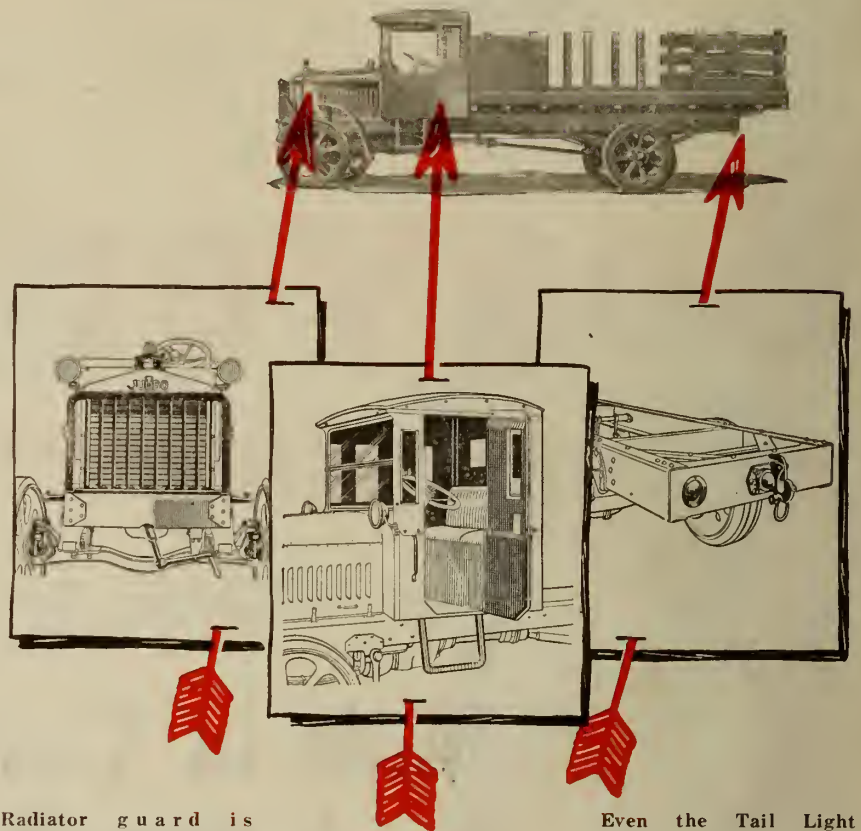

Radiator guard is mounted independent of radiator. Shutters controlled by driver assure maximum engine efficiency at all times. Frame extended in front forms bumper. Over-size ball thrust in steering knuckle gives Jumbo Trucks the steering ease of a passenger car.

The Steel Cab is part of the standard equipment on Jumbo medium and heavy duty models. Foredoors with sliding sash curtains opening with doors. Heavily stuffed cushions provide comfort for driver. Clear vision windshield set in rubber to prevent rattling.

Even the Tail Light bears evidence of Jumbo engineering skill. It is a minor detail but the little things count in truck construction. The tail lights in Jumbo Trucks are mounted flush in the frame to prevent breakage. The spring Draw-Bar is another feature of Jumbo Trucks.

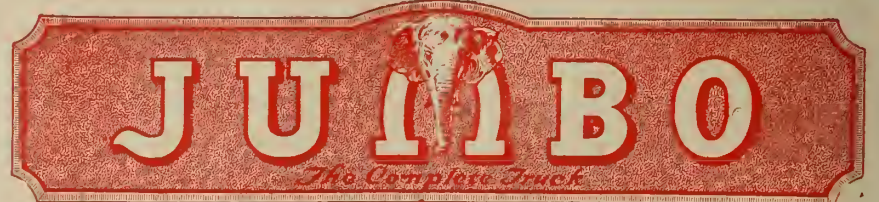

Manufactured by  
NELSON MOTOR TRUCK COMPANY - SAGINAW, MICHIGAN, U.S.A.

---

**MOTOR CAR DISTRIBUTORS LTD. Sole Canadian Distributors**  
27 McGill College Avenue, Montreal, Que.

---



# CANADIAN MOTOR, TRACTOR AND IMPLEMENT TRADE JOURNAL

Published Monthly by THE MACLEAN PUBLISHING COMPANY, LIMITED, TORONTO

MONTREAL, Southam Bldg.

WINNIPEG, 1103 Union Trust Bldg.  
NEW YORK, 1133 Broadway.

VANCOUVER, 314 Carter-Cotton Bldg., 198 Hastings St. W.  
BOSTON, 734 Old South Bldg.

CHICAGO, 405-6 Transportation Bldg.

LONDON, ENG., 88 Fleet St., E.C. 4

VOL. II, No. 9

TORONTO, SEPTEMBER, 1920

Subscription Price  
\$2.00 Per Year

## Apollo

### BRASS SPARK PLUGS

—are sure and satisfactory sellers!

You're on a good thing when you handle APOLLO PLUGS—they represent the highest standard of British plug manufacture, are fully tested to ensure maximum efficiency and are guaranteed to give complete satisfaction.

With the APOLLO range of plugs you can promptly meet every plug request—there are models for every type of Car, Motor Truck and Tractor engine—and every plug carries a GOOD PROFIT for YOU.

Super Mica Plug is specially designed for high-speed, high-compression engines. It is unaffected by excessive heat and of exceptional durability—a plug that gives a quick start and adds power to the Engine. Retail price ..... **\$1.25**

Porcelain Plug is specially designed for the FORD engine. It has Solid Brass body, 1/2-in. gas thread, is clean to handle, will not rust, fits the special Ford spanner, is insulated with finest porcelain and is detachable for cleansing. Retail price ..... **90c**

Get on to the APOLLO PLUG proposition and you'll do big business in selling plugs. We can give prompt shipment of all models and supply you with posters, showcards and advertising literature. Write us for trade terms and full particulars of our models.

### APOLLO PLUG MFG. CO.

Canadian Head Office:  
135 King St. West, Toronto. Factory: Birmingham, Eng.

Plugs for all engines



APOLLO  
No. 1.  
Super  
Mica  
Plug

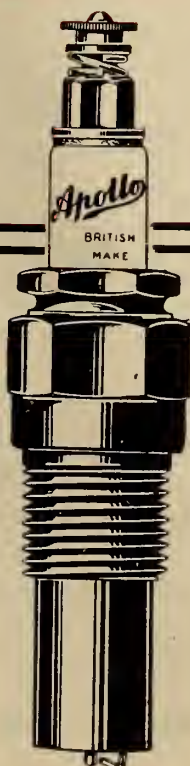

APOLLO  
Special



APOLLO  
L.C.B.  
Special  
FORD  
Plug

Overtime  
Tractor  
Plug



# The Wedge Does It

## The Mighty Force that Holds the Reins of Power

The finest motor in the world cannot deliver the power which it is otherwise capable of furnishing if there is loss of compression.

To fully protect themselves against loss of compression by their engines, thousands of motorists are utilizing the mighty force of the "Wedge"—by installing WEDGERITE PISTON RINGS.

As the WEDGERITE equipped piston comes up on the compression stroke the impenetrable "wedge" pressure of these remarkable Rings prevents the slightest escape of gas or oil. Result: Perfect compression; 100% generation of power.

Ask your repair man to show you these fuel and tire-saving rings.

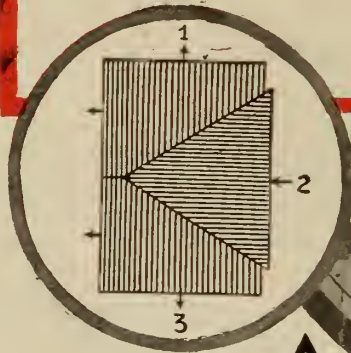

↑  
THE  
WEDGE



CROSS SECTION OF RING  
SHOWN IN CIRCLE

- 1—Section pressing outward and upward.
- 2—Spring section of ring.
- 3—Lower outward and downward section.

### ILLUSTRATING THE WEDGE PRINCIPLE

The wedge principle employed in the making of WedgeRite Piston Rings is shown in the accompanying drawing. Its superiority, measured by its ability to expand in WIDTH as well as in diameter, means utmost satisfaction for motorists. The repairman who uses WedgeRite Rings is one who can be trusted. By using the Best Piston Ring he shows a real desire to give you better repair service.

# Wedge Rite

PISTON RING  
COMPANY  
LIMITED

92 Notre Dame St. E., Montreal

ORDER FROM YOUR FAVOURITE JOBBER



# Sell "Good Old British Reliability"

Sell the line that is already half sold—the "Good Old British Reliability" Lister line.

The man who can put "Lister" on his signboard has a long start on his competitors. Join up your own reputation with that enjoyed by the Lister name and you have an unbeatable selling force behind you. Now is the time to sell the

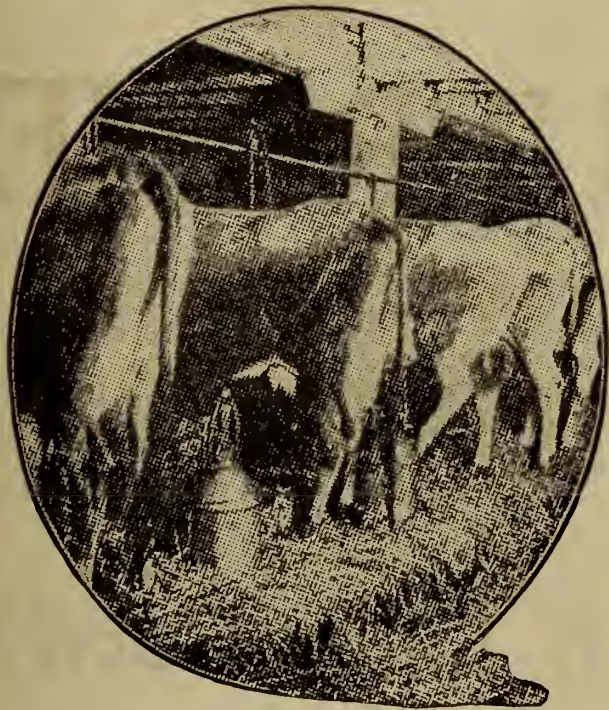

## LISTER MILKER

Our advertising has taught farmers everywhere to look for **reliability**, and the machine in operation never fails to make good.

The Lister is the milker of milkers on which you can stake your reputation and make money.

The Lister is simplicity itself—any intelligent person can run it from the start with ease—fewest parts to get out of order.

Other Lister Lines of Reliability: The famous Melotte Cream Separator—Lister Engine—Lister Silo Filler—Lister Grinder—Avery Tractor.

### Some Lister Points of SUPERIORITY

1. Easy to install.
2. Easy to clean and manage.
3. Easy to connect with any form of power.
4. No oil or dirt gets into the milk.
5. Low cost of up-keep. Parts easily renewed in case of accident.
6. The Lister Patent Vacuum Tap makes it unnecessary even to pull off a rubber hose during the milking.
7. If you need extra capacity you can add more milking pails without any fuss.

We gladly furnish fullest particulars and stand behind every machine we sell. Write to-day for literature and attractive proposition to dealers.

## R. A. Lister & Company (Canada) Limited

58-60 Stewart Street - Toronto



# *"The Wonderful Gilson"*

MADE IN CANADA



## IT STANDS SUPREME

### REASONS WHY:—

- 1—Your Customers demand the Gilson—Easy Sales—Big Commissions.
- 2—It has the largest sale of any Silo Filler under the British Flag.
- 3—Its wonderful performance brings repeat orders.
- 4—It is the lightest running blower cutter made.
- 5—Our entire organization is behind you.

## *Frankly Now, Doesn't It Look Good?*

You cannot afford to let this proposition go.

Don't put it off—write for our special agent's proposition at once.

Tear off, fill in and return the corner of this page. If you don't someone else will.

## IT MEANS DOLLARS TO YOU!

### Gilson Mfg. Co.

LIMITED

Factory and Head Office:  
10118 York Street  
GUELPH, ONT.

Branch and Warehouse:  
10128 Elgin Ave.  
WINNIPEG, MAN.

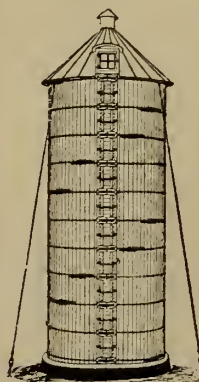

### The Hylo Silo

No farm is complete without the famous Hylo.

**BIG PROFIT—  
EASY SALES**

*Something worth adding to your lines.*

Without any obligation on my part you may send me your agent's proposition on:—  
(Put an X opposite the product that interests you)

Silo  
 Silo Filler  
 Engine  
 Thresher  
 Manure Spreader  
 Tractor

FILL IN AND RETURN AT ONCE  
Tear Off Here

Name .....  
Post Office .....  
R.R. No. .... Prov. ....  
Remarks .....



# Burlington Steel Fence Posts

**Strong --- Permanent --- Economical**

Offer an unusual opportunity for Dealers to build up a profitable business at small expense and effort. The demand is increasing.

Our experience in manufacturing special steel bars for reinforcements has been of untold value in the making of steel fence posts. These posts are made of the same high quality of steel as used for concrete reinforcement and for other purposes where strength and rigidity are absolutely necessary.



The Clips easily and quickly put on. Made of Galvanized Wire. About forty to the pound.

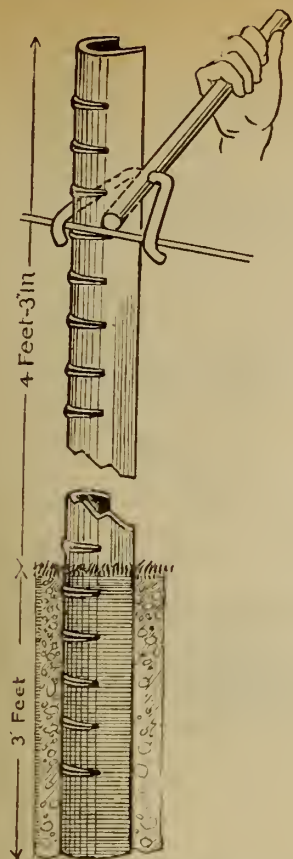

Placing the Fastener in position.

## The Special "U" Shape

The "U" shape is exclusive with our posts. It allows the post to be driven easily and straight. It makes it anchor firmly and prevents sagging or bending. No sharp points—no special devices needed to hold it in the ground. Can be set in place in a fraction of the time required to set wooden posts.

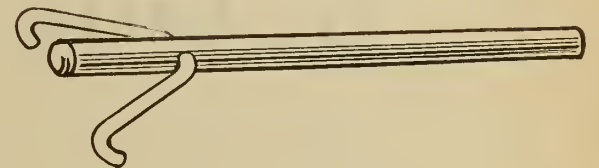

Clip Fastener is simple and efficient. Fastens clips quicker than staples can be driven.

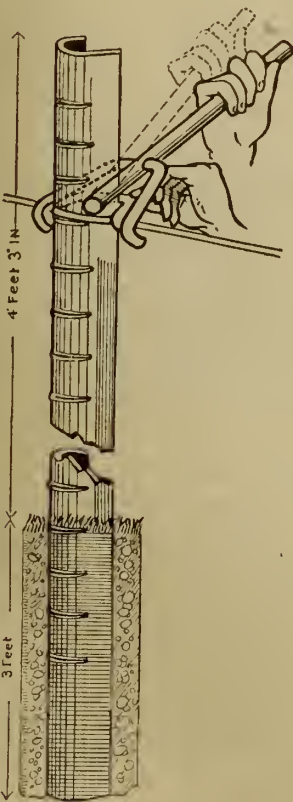

Putting on the clip. Right hand works handle. Left hand places clip.

## The Clip Fastener

fastens the clips quicker than staples can be driven. Clips hold the fence tight. It cannot slip.

## DEALERS

Nation-wide advertising is placing the advantages of Burlington Steel Fence Posts before the farmers of Canada. Our special book on Steel Fence Posts and sample section mailed on request. Cash in on the demand in your locality. Sell Burlington Steel Fence Posts. Immediate delivery from stock.



Section of Post, showing actual size: Note unusual thickness.

# Burlington Products, Limited

325 Sherman Avenue North

HAMILTON, CANADA





## In Line for Big Business

Cletrac dealers are in line for big business this fall if they get in their orders early. Our enlarged factory is driving ahead on production, but orders have yet to be filled in their turn. If we are unable to supply any dealer on time it will be his own fault in failing to send in his requisition early enough.

Cletrac's popularity is growing daily. Farmers are recognizing that the sturdy Cletrac travelling "wheels-on-track" is the most adaptable and dependable source of draw-bar and belt power on the market. Cletrac showed its superiority over all others from the beginning. It has proved itself a speedy seller. Dealers are finding Cletrac a mighty profitable proposition to handle. Satisfied Cletrac owners are help-

ing sales by proclaiming Cletrac's merits from the Atlantic to the Pacific.

We have very generous dealer terms for you. Good dealers everywhere recognize Cletrac's superiority—that is the reason we have been unable to meet the demand. Get in the Cletrac line-up. Get and study Cletrac literature. Cletrac will boost your sales by leaps and bounds.

*But--get your orders in early*

**The Cleveland Tractor Company  
of Canada Limited**

Head Office  
WINDSOR, ONT.

Western Sales Office  
REGINA, SASK.



# JOHN DEERE LINES FOR JOHN DEERE DEALERS

$\frac{1}{3}$  Less Parts to get  
out of order

Light Draft, Big Drive Wheels  
Wide Spread Only Hip High,  
Endless Apron. No Follow-board.

Gears are covered  
watertight and cannot freeze or  
become clogged.



“The SPREADER  
with the BEATER  
on the AXLE”

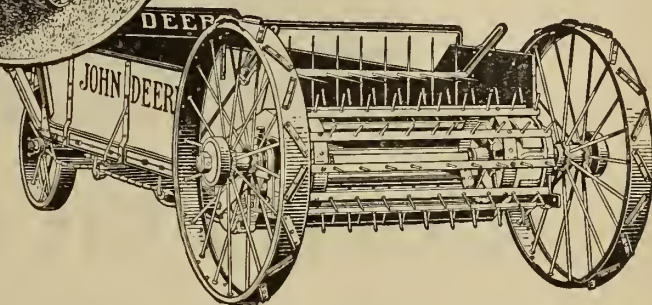

## “WATERLOO BOY” KEROSENE ENGINE

Powerful — Durable — Reliable

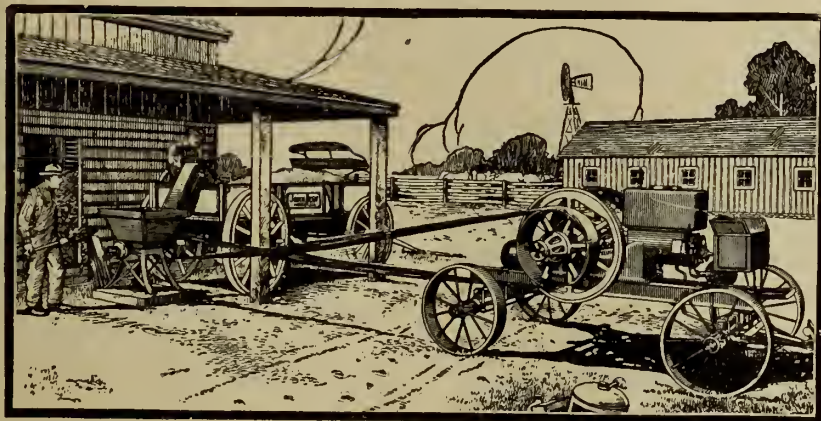

The perfected Kerosene Engine.  
The result of twenty-five years' manufacturing experience. It is simple  
and carefully proportioned and built on the four-cycle principle.  
JOHN DEERE quality is back of these engines. They are giving perfect  
satisfaction everywhere. Built in sizes from 2 to 25 horsepower.  
Every farmer in your district, who does not own an engine, is a prospect.

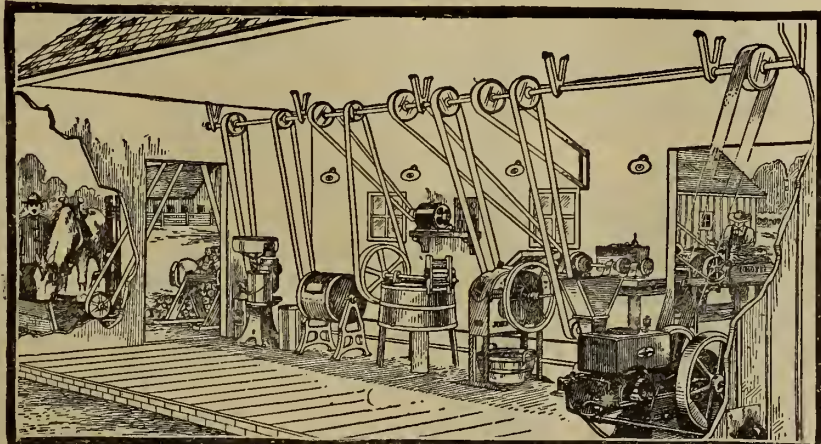

Now is the time to sell Manure  
Spreaders.

The crops are off and the far-  
mer is preparing to get ready for  
next season's harvest.

The advantages of Power on  
the farm are fully recognized  
by the farmer. The “WATER-  
LOO BOY” Kerosene Engine is  
the logical solution of the power  
problem.

JOHN DEERE QUALITY is  
back of these lines and back of  
all is the JOHN DEERE policy  
of selling only through dealers.

Write to-day for full particulars  
and open territory.

The  
John Deere Manufacturing  
Co., Limited

WELLAND



ONTARIO





# Corn Harvest Brings You Sales Harvest

A CASE Kerosene Tractor means speed, economy and efficiency in the harvesting of the corn crop, as compared with the sweltering labor of the slower and more expensive process of cutting by hand, or with horse-drawn implements.

Use the corn harvest as an opportunity to reap a harvest of Case Kerosene Tractor sales.

The 10-18 Case Kerosene Tractor has ample power to operate any corn harvester or small cornhusker and shredder. The 15-27 or 22-40 Case Kerosene Tractors will do the same work with the same efficiency, and have the greater power

required for heavier work on belt or draw-bar, especially on farms of great acreage.

The illustrations show a 10-18 Case Kerosene Tractor drawing a corn harvester, and the same tractor, later, furnishing belt power for husking and shredding the same crop.

Case Kerosene Tractors are mechanically capable of long service, and agriculturally adaptable to any service requiring dependable farm power.

Write for catalogs showing why Case Kerosene Tractors are salable in every month in the year.

**J. I. CASE THRESHING MACHINE CO.**  
(INCORPORATED)

Dept. O-9, 345-9 Dufferin St., Toronto, Ont.

*Making Superior Farm Machinery Since 1842*

To avoid confusion, the J. I. CASE THRESHING MACHINE COMPANY desires to have it known that it is not now and never has been interested in, or in any way connected or affiliated with the J. I. Case Plow Works, or the Wallis Tractor Company, or the J. I. Case Plow Works Co.

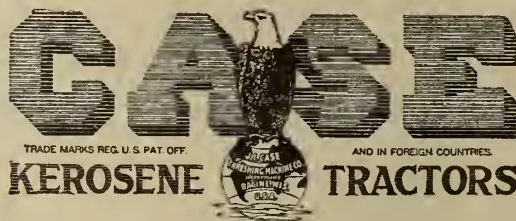

Look for the  
EAGLE  
Our Trade Mark





# CANADIAN MOTOR, TRACTOR AND IMPLEMENT TRADE JOURNAL

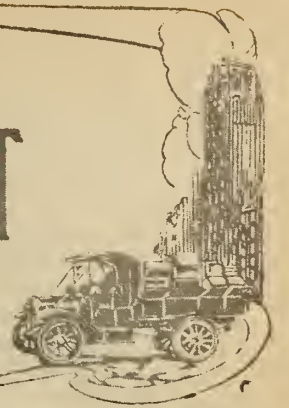

Volume 2

TORONTO, SEPTEMBER 5, 1920

Number 9

## The Use of Tractors for Orchard Work

**T**RACTORS are so commonly referred to as the "farm tractor" that we are apt to overlook their value for other lines of productive work. Power farming is becoming as much a part of the routine of fruit growing as of agriculture, and the big orchards of the country are finding the tractor to be a necessary part of their equipment.

Pacific coast orchards are famous all over the world, for the fruit grown in them finds a ready market in all countries. Where the distance is too great to permit of the shipment of fresh fruit, the product reaches the market in cans, or in a dried state. Through co-operative organizations for the marketing of the products of their orchards, horticulturists in that district have developed their industry to an extent requiring the production of crops of uniformly high standards, and the growers are quick to adopt any new machine or method that will enable them to keep up their standard. In many sections of California, the orchardists were the first to appreciate the value of tractors in keeping their soil in proper condition, and they bought the machines and put them to work while many agriculturists were debating whether they could afford to try them. As a consequence, wherever one goes throughout the fruit raising sections of the Pacific coast the tractor will be found working in the orchards. Not only is it used in field operations, like plowing, but it is used to a considerable extent in hauling fruit and supplies. With it the fruit grower is able to put in cover crops to enrich the soil, and in orange culture, where the mysterious but disastrous "June drop" occurs, the tractor has helped many owners to reduce materially their loss from this annual visitation.

On account of the overhanging branches of fruit trees, the type of tractor best adapted to orchard work is the small, low endless belt or tracklaying machine. To meet the needs of the orchardists, practically all of the orchard tractor manufacturers put out small models, possessing considerable power, but low in height and capable of plowing close to tree trunks and turning sharp corners. With these machines, and specially fitted plows, it is possible to plow up the ground to within a few inches of tree trunks, and the damage to overhanging branches is not nearly so great as with horses. By an adjustment of the plow blades it is also possible to avoid cutting off the tree roots and feelers found near the surface, and in all respects the tractor has been found to be a superior source of power for orchard plowing. The even distribution of weight of the track-laying tractor also prevents packing of the soil, as often happened when horses had to be manoeuvred in orchard corners hard to turn in and they stamped about a great deal.

**I**N many respects orchard plowing is harder than ordinary field plowing, because there is not the free space to work in. When horses are used, the necessity for plowing around trees subjects them to unusual strains and there is more friction from the harness, developing numerous shoulder sores which frequently incapacitates the work stock when most badly needed. One orchardist who used a tractor and horses on his place declared that his machine

By F. H. SWEET

was worth the cost just for the deep plowing alone, as with it he could save his work stock for the lighter jobs and always had them in fit condition for any job.

In developing tractors especially designed for orchard work the manufacturers found their greatest difficulty to lie in the necessity to negotiate a full load on a very short turn. Some manufacturers retain the differential drive, but provide easily operable brakes on each side of same to allow the operator to retard or to stop the pivotal track while pulling the load and turning with the other. Some manufacturers have done away with the differential drive and made use of a design which gives to the operator two easily operable levers which control individual clutches, one for each track, so that a turn may be made by slipping or throwing out the clutch controlling the pivotal track, allowing the turn to be made and the load pulled by the other track. Still another type of tractor is built to utilize only one track. This single track is mounted in the same frame on which are positioned the engine and transmission means for driving the same, and the entire outfit is supported by and steered from a frame held on two rear wheels, whose axle forms the drawbar for attachment to the implement. By this arrangement the entire load can be easily and quickly turned in any direction.

**I**N MANY orchards, where a tractor of sufficient power is available, the outfit is so adjusted that plowing is done up one row and down the other. The machine will pull subsoilers, clod-mashers or other implements, and sharper turns can be made than with horses.

The tractor motor is frequently utilized by or-

chardists in operating a spraying machine. By mounting the spraying outfit on the tractor it can be moved about from tree to tree, and the spraying mixture pumped under pressure by the motor.

One man owns six hundred and forty acres of land, of which three hundred are in orchard or vineyard and the balance used for grain. Before he bought a tractor, this man kept from sixteen to eighteen mules on the place, which required the assistance of a hired man. At certain seasons of the year he hired from twelve to twenty extra head and more laborers. To-day, with an 18-horse power tractor he does all the work alone and there is not an animal on the ranch. In speaking of his experience with a tractor, this man says:

"The saving of trees and vines cannot be estimated. I have lost but few if any trees through bruising or skinning in cultivating with the tractor. My cost for caring for trees, vines and grain crops is one-fourth of what same would be with stock when one figures labor, feed for stock, and board for men."

Another owner has found that through the use of a tractor his apple crop will average eighty per cent. "extra fancy," thus commanding a premium. This result he attributes to the timely cultivation and spraying he is able to do with the machine. He uses the tractor to pull his spraying machine because he can pull it through the softest spots in his orchard with the tanks full of spraying mixture, a thing he has found impossible to do with horses. The tractor is also used for performing all kinds of work in the orchard, from plowing to hauling the apples to the packing plant.

### Welland Gets Rubber Plant

**M**ANUFACTURE of hard rubber goods, plates and cells for batteries, etc., will be undertaken in Welland by Joseph Stokes Rubber Company, of Trenton, N.J., who have acquired a three-acre site in that city, adjoining the Grand Trunk Railway. The new plant will be directly opposite the Canadian Billings-Spencer factory. It is proposed to start erection of the rubber factory as soon as material can be placed on the ground. Karno-Smith Company, of Trenton, N.J., who have conducted the investigation for location, have been awarded the contract. G. N. Robinson of the above company is in charge of the field office that is being erected on the site.

The size of the first unit will be 65x160 feet, with a separate power house and office. The railway spur is being laid the entire length of the property, so that shipping facilities will be available to other units as they are added. The company expect to operate by December and estimate the number of employees at 150 by the end of the second month. About 1,500 people are employed by the parent organization in Trenton, N.J.

The company will be incorporated under an Ontario charter, and a by-law will be submitted to Welland ratepayers at the next municipal election giving a fixed tax assessment to cover everything except special and school taxes for a ten-year period.



"What's the matter, doesn't he teeter?"  
—Donahey in Cleveland "Plain Dealer."



# Problems of Saskatchewan Auto Dealers

In Spite of Discouragements During the Past Year the Saskatchewan Dealers Are Looking Forward to Big Business by Reason of the Large Wheat Crops

By G. H. SALLIANS



**N**EVER, in the history of the automobile industry, with its ups and downs, has there been such a year for business as the one just ended. Never, since the first gasoline wagon appeared, have so many discouraging elements developed within the compass of twelve months, constituting a formidable whole that has well nigh crippled the mainstays of the dealers' world, and has entirely burst the bubble of prosperity for a large number.

And yet, with such a period of general rotteness in conditions just behind them, the dealers of Western Canada are able to perk up, throw out their chests and say: "This fall we'll have a good business. Every seller should get his surplus after this crop."

The reason for the optimism will be manifest after a glance at the prairie wheat fields, for without a wheat crop the west is not, and with a wheat crop it most decidedly is. And the honor and glory, and the spirit (more or less dauntless after all) and the commercial pulse of the great west are mirrored faithfully in the automobile industry. There you find the reflection of every ache and pain, great and small, of the joy attendant on a successful reaping, and of the wholesome and just discontentment resultant from a safety razor harvest, and lastly, but by no means least, the partially camouflaged but all the more pitiable confusion which is the offspring of financial discomfiture.

Having stated that last year was a rotten one for business, that the present is no better, and that next year is going to see a big change, it is well to remember, before going further, that in looking at the automobile industry of the west we of necessity view it as a rural thing. It is not the few scattered centres of the prairies that swallow the finished product and its necessities of life, prominent among which are gasoline and accessories. By no means.

Go to the fields. There is where you will find the heart of the motor dealer, there is where you can lay your finger on the pulse of his business. This of course, applies to other lines, but we are just at present strafing the automobile problem with what effectiveness we can muster.

In plain figures, ninety per cent. of the motor dealer's business lies in the country. The other ten per cent. is found on the paved streets. That is believed a fair estimate, and explains in short how vital is the head of the golden grain to his family table, whether he sells twelve cylinder palaces or four cylinder road lice.

But to get back to the crux of the whole matter, the why and wherefore of the commercial ennui which has smitten the automobile trade as a sleeping sickness, until some of its victims have passed peacefully out, still asleep (this last applying, believe me, to that particular atomical part called the agency, and not to the man concerned in the perpetuation of it—for he has been troubled with no superfluity of somnolence.)

In the first place, the staggering blow came to western business, this from the dealers themselves, about the middle of last summer, just before the fields where there should have been wheat would have been yellowing in the ardor of the sun, provided there had been anything to yellow, which there was not in many places. In scattered cases the adventurous soul proceeded, drawn by the joyful sound of the exhaust, fascinated by the mobility of the buzz vehicle, and heedless of the gaunt and lean days which the grasshoppers chanted in their seedy voices, as they jumped from meadow to meadow, finishing off

what few stocks of wheat had inadvertently come on toward maturity. But in most cases the prudent one filled and trimmed his lamps while yet he might, gave heed to the faint but long-drawn moan of the wolf, which he estimated might soon become a howl, got down to plain food and broke the news to the family.

So far so bad. The winter followed, early enough in all truth, smothering in a blinding snow storm what forlorn hopes remained of a fair season in second-hand stuff throughout the fall. By the middle of October a large part of the west snuggled under the white blanket, which lay on it like a pall until late this spring. Thus 1919 passed. Even at that, most dealers had disposed of the bulk of their stuff, and were dug in for a fairly good winter of it, having

forthwith come through with an entirely new list, and must by no means sell over the list price.

This has been found to work in the following manner: A certain article, accessory or repair, costs two dollars, counting exchange, and all other things. Next day, owing to exchange, or an advance from the factory end, it costs \$2.17, next day \$2.20, next day \$2.15 and so on. There are about one million parts, more or less, in the sum total of automobile fixtures which must be handled by the dealer. A new list costs about \$200 in the preparation. This meant \$200 per day—if strictly adhered to. In other words, it does not work at all.

Then, in fast succession, came a series of sledge hammer blows to the trade in motors in the west. There has been a government tax of 10 per cent., later 15, the wholesalers' tax of one per cent., more recently the additional freight, about 40 per cent., and further advances in price by the factory, until to-day, united with the omnipresent exchange bugbear, they have formed an almost insurmountable obstacle in the way of good business.

A car costs \$1,500 in the city of its making. By the time it gets out west, with 42 per cent. duty, 15 per cent. tax, one per cent. turnover tax, 40 per cent. more freight, a small addition necessary to allow for incidentals, it has advanced in price, in round numbers, from 75 to 100 per cent., and the dealer is powerless to prevent it.

After he gets the car here, surmounting great difficulties in so doing, he finds that his troubles are commencing with a rush. First there is the great dearth of cash, which must always be considered. Take a note, six months, eight months, a year, whatever it may be. This is not always, but sometimes. Now for repairs, get enough on hand to supply all these cars for five years. Perhaps 50 per cent. of them will never be turned over, but will accumulate a certain amount of mould, a large portion of antipathy, and lie in the store-room for five years, representing five, ten, fifteen thousand dollars dead capital, dead loss to the business.

All this has been fairly dismal, not a ray of sunshine anywhere. But the automobile business always looked rosy, pretty good money on everything, and all that. So rosy that, after staying in the shop for eighteen hours out of every twenty-four, the garage man, or the dealer, looks over his array of chattels and takes account of his stewardship unto himself, and finds that he has perhaps lost what money he did at one time possess. Many of them have made good, but by no means most of them. There has been too much against them.

As a matter of fact, 8 per cent. of them have come through, made absolutely good. The other ninety-two have remained stationary, gone back, or gone out of the business and into something else. This represents general business in the automobile industry, and does not apply to any particular area. For after all, the trade is not rosy. It is not a soft job. All dealers know that. It is a business of many discouragements, outnumbering by many the encouragements. A man comes in with a car, gets it fixed, thinks it ought to run for a year with that repairing. Perhaps it took two hours. He thinks it should have been done in fifteen minutes—and says so. Perhaps he got a spare part. Cost two dollars. Should have cost thirty



The Saskatchewan dealer has been hard hit by the Saskatchewan Auto Repair Act.

enough in prospect to keep them in the game.

Then the spring opened up and with it came a short and somewhat deceiving spurt to the trade, arising from perfectly natural causes, but lending a highly colored promise nevertheless. Then this died down and second-hand business had its day, short, serene and happy, before it also was relegated, and both aspects of the business settled down for a sub-normal summer, just as they had dug in for the winter.

For just a moment we have to localise, for Saskatchewan was hit hard just about this time by the legislature. That august body evolved what has since been regarded by many as one of the most marvellous acts of modern times, being entirely unworkable from start to finish. With slight amendments it was finally passed, obligating the dealer to keep repairs for everything he sold, for a period of five years, and worse than that, to keep the secretary of the department supplied with an up-to-date list of all things whatsoever handled by him or through him, their price, his price and all other prices. If these were to vary by the smallest fraction he must

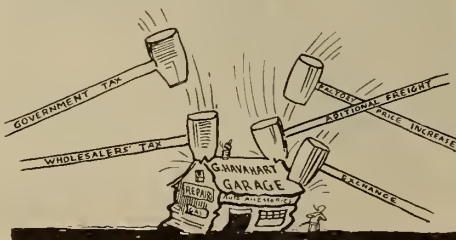

A series of sledge-hammer blows.





cents, he says. This is more or less a matter of soft soap in city or town trade. But it becomes serious when it comes to out-of-town trade. In this way. One dealer told me it cost him from twenty-five to thirty dollars a month for small things which had been turned back by intending customers at country points. Carrier charges on these are a small thing in themselves, but in aggregate they make a significant break into the profit margin, and eat a respectable hole into the auto-man's expense account.

"I have travelled all over the two Americas, and have worked at many things. I thought I had learned to study humanity. Then I came to this town, and got into the automobile business, and I have learned more about human nature in five years than I did in all my life before." This from one man. He has found out that psychology is a great thing in the garage.

"What will be the upshot of all this?" I asked another dealer, after he had told me his business in general was fair, though the selling end was flat.

"It means that cars are going so high that customers won't buy them," he said.

"But," I persisted, "if they have the money (I jingled a few forlorn coins in my pocket as I spoke and added, 'which they have not') they'll buy a car now just the same as they would have years ago. Cars, after all, haven't advanced disproportionately to other commodities."

He said this was right. He then admitted that he had been fortunate, having disposed of all his spare stuff, second-hand and otherwise, in spite of times which could scarcely be called hard—prudent is the better word—and that he looked for a big change. Boiled down, his opinion was the same as others, that the wheat fields would tell the ultimate tale. That the West is full of optimism. That this opti-

mism cannot be downed, though it may be temporarily stifled.

So I hied me to a second-hand king. He runs a big garage, does all sorts of repair work, which is merely paying expenses in the West as in other countries, and depends in the main on sales and quick turnovers. He did some calculating. Used a cent piece on the brick wall. Last year he had turned over three times the business he had done this year. Would the increased freight charges, and the Government tax and those other evils, boost the second-hand business?

He said it would, undoubtedly. But he added a rider that it had not done so up to the present. Hundreds of men have come in with their cars, trying to sell them. Not getting as much cash as they had vaguely hoped for, they keep their burdens, and continue to pay the cost of running them. Just sort of hanging on. Don't know what they will eventually do, but they intend to wait and see. This, I took it, was a good omen for the second-hand business.

But against all this there is the indisputable fact that the big, expensive car is selling in the West, even this year. The two extremes, the great big bus, and the tin lizzie, are moving ahead, and centre is slowed down, just for the time.

Perchance, I met an automobile man in the street. I had just sauntered across the said street on the dead run, looking both ways at once. Four expensive cars and five Fords had come at me simultaneously from different directions.

I said to this man: "You fellows shouldn't kick about hard times. Look at the cars on this one street." He looked. So did I. In the one block there were nearly sixty cars parked. Fortunately, this town has wide streets, so that the parking is not the evil it might otherwise be.

"Yes," he said, "but they're all standing still.

They're not running." Accuse him of a commercial soul as I would, large numbers of cars passing to and fro notwithstanding, I could not but see that he was right. His expert's eye had seen what I had missed. There was somewhat of a languid air about all these cars. True, the number in motion was large, but infinitesimal as compared with those at rest.

I figured. It was my turn. Ninety-five per cent. or more of these cars always standing. The other five per cent. or less running, and part time at that. Where did the repair business come in?

It is a fact. A more prosperous year would have seen a bigger proportion of them in motion—in the summer months particularly. Some, they say, have housed their cars, say they can't afford to run them. But these, I believe, are few, judging from what the dealers say.

But all this is a matter of season only. Given a good crop, which the west has this year, the automobile business will see a greater boom than it ever had, in spite of the higher cost of gasoline. The call of the buzz buggy was never so strong as it is to-day. Bank clerks are buying them. Drug clerks run them, office men of all kinds have them, even newspaper men are trading off their old ones for new. It is the age of cars. That phrase is hackneyed, but nevertheless startling, in view of the staggering blows the industry has had recently. In the west, particularly, the car is not now a luxury, it is a necessity. (As I write a blow-out has occurred beneath the window. It will cost twice as much to repair it as formerly. But it will be repaired).

And the trend is not toward the cheaper car, the every day or garden variety. It is to the soft cushions and the rocking chair, gliding effect that can only be acquired by large expenditure. Where the dollar has lost in power, it has gained in numbers, and that factor is the root of all.

# Abuse of "Service" in Automotive Trades

IT is high time, to my way of thinking, that some definite stand was taken on this question by the whole "trade."

There is no other line of merchandising in which the customer expects or gets so much for nothing under the claim of service as he does in the automobile and associated lines. The reason for this state of affairs is solely through the lack of some definite outline being laid down and adhered to by dealers, of what shall constitute service.

In his district a dealer will do practically all running repairs for the whole of the first year charging it to service, in spite of the fact that manufacturers very plainly state a much shorter time in their advertising matter wherein they will replace any defective part. When the manufacturers offer to replace the part they say "this does not include fitting it to the car or taking the old one out." Why, therefore, should the dealer, who is really just a small part of a manufacturers' organization, take upon himself to do something that his principal will not. It is not as if he got an exorbitant profit on cars; as a rule the best it will run is 15 per cent. Unless a manufacturer did not make more, and a good deal more, gross profit on his goods, he would soon be "in the hole;" for remember when a manufacturer tells you he is only getting 10 per cent. or so profit on his goods, he has made allowance for all overhead and other expenses and the 10 per cent. is absolutely clear profit. Whereas out of the 15 per cent. or so discount he is good enough to give you, the dealer, on his goods you have to pay the operating expenses of your garage, such as rent or interest on the value of your building, taxes, light, telephone, mechanics' wages, gasoline and tires used in demonstrating, and salary to yourself—for you would be worth something surely if you were working for another firm. After you have paid all these items, what you have left may be termed "profit" and more than likely you will find it pretty slim.

BUT wait a minute, we have still to consider the claim "Service" makes on the little profit you were deluding yourself you had left. Maybe you will be called on to replace some part or parts on a car that you know were necessitated by the owner's own fault. You have no definite proof of this, so, instead

By A. M. GLOVER

of making a "kicker" out of a man, you replace it free and call it service. You do this just because you think your competitor round the corner is laying in wait to steal your prospects, and might use this kicker as a lever to pry some of your customers away from you.

If we could get all together and lay down a definite limit to what we would do under "service" we would all make more money; and in the end the customer would be better satisfied for he would know just what he could not expect and when we refused request for some free repairs, instead of him wishing he had bought the other make of car, feeling they would have done it free, he would know that when we refused to do that work under service all the others would turn it down too.

This idea does not apply only to automobiles, it applies to every line in our business including tractors, tires, batteries and all other equipment. The big idea to get hammered into the customer is that "service" does not mean "something for nothing" but that it means having on hand the parts a customer wants, when he wants them, and at a fair price.

It is too much to expect that this abuse will be wiped out within a short time but it will have to be wiped out before the business is on a satisfactory basis and if we never make a start it will never be done. Does a shoe dealer keep your boots in repair for 12 months just because you bought them from him; or the tailor your suit pressed up and all the buttons on? No, not by a long shot. If anything goes wrong with the boots or clothes he will tell you to send them back to the maker and he will probably address a label for you but that is as far as he will go.

I could give countless instances of what I have seen demanded on free service and the customer has got away with it. One instance was where a man had driven his car 4,500 miles and it developed a knock when idling. He demanded this eliminated under service. The firm knew he was not entitled to it but as he was a man of some importance they decided to go ahead and do it even though he had long overrun his legal guarantee. The knock still

persisted after bearings, etc. had been tightened up, and finally it was necessary to put in a new set of cylinders and pistons with a good many other parts at a cost of about \$400. He had given the whole engine a bad twist which threw it out of alignment by overdriving it in winter and on rough roads. In all fairness he was not entitled to a single copper's worth of work but because he put up the service cry and because the dealer wanted to keep him quiet he got away with it.

A great many customers also think that you should clean out the carbon and grind the valves once or twice under service. Why should you? Carbon will form in any engine, and valves need regrinding through no fault whatever of the engine; they have absolutely no ground for their claim but they get away with it on the ground of service.

It seems that the old proverb "Give him an inch and he will take a yard" was never truer than in the case of some automobile owners, for the more you do for them the more they will expect. They will soon be expecting us to keep the wheels and whole chains greased and oiled up, and after that we will in addition have to keep the car washed and polished under service.

It is time a firm stand was taken and a definite limit laid down on what will constitute Free Service for we are in business for our own good and not merely for the benefit of every Tom, Dick or Harry who happens to buy a few goods from us. By this I do not mean to say that we are not to extend the courtesies of good business but I do mean to say that we should consider our own interests as well as the customers'. It is well to remember that it needs two to every deal, a buyer and a seller, and the seller is just as important as the buyer and is entitled to consideration just as the buyer expects consideration.

Remember most any argument for free service can be made to work both ways.

THE Tractor Bearings Division of the Hyatt Roller Bearing Company has just issued a series of folders covering the use of anti-friction bearings in various kinds and types of farm equipment, including motor cultivators, threshing machines, plows, binders, ensilage cutters, windmills, etc. A separate folder is devoted to each machine.



# Farm Machinery and Autos at the C.N.E.

## Largest Display of Power Farming Machinery, Trucks, Automobiles and Accessories Ever Seen at Toronto Fair

IT was evident to even the most casual onlooker, when viewing the farm machinery and automobile displays at the Canadian National Exhibition this year, that Canada as a nation believes in being thoroughly motorized. Thousands of people

rim. The four extra wheels are approximately the same size as the regular tractor wheels. The makers say with this outfit the tractor can make from 9 to 15 miles an hour.

Though the makers of all three types of tractor—

A distinctly new tractor to the Canadian market exhibited is the Samson model M, manufactured by the Samson Tractor Company, of Canada, Limited. It is a four wheel tractor and is designed to furnish heavy draft horse power at the draw bar and belt and is equipped complete with governor, power take-off, platform and fenders and brackets for canopy top and regular cleats. This tractor will be available for the Canadian dealer and farmer by October 1st. The I.H.C. exhibited and have put on the Canadian market their new Dunham Culti-Packer operated by a tractor; it is a combination pulverizer, packer and cultivator.

THE other power farming machines such as gasoline and kerosine engines, milking machines, cream separators, farm lighting plants, etc., etc., were well represented. The Renfrew Machinery Company's new engine run on compression—no carburetor, batteries, spark plug nor magneto—created much interest.

Practically all the manufacturers of milking machines were represented. A number of the firms represented reported that business in this line had been remarkably good.

A new farm lighting unit was exhibited by the Dominion Steel Products Company, Ltd., of Brantford, Ontario. The Dominion Light is a self contained power-developing unit, with an auxiliary storage battery equipment to meet 24-hour demands for electric current. It has a rating of one K.W. (1,000 watts); height 36 inches, floor space 19x26½ inches, and 532 pounds in weight. The engine is 2 1-4 h.p., bore 2 7-8-inches, stroke 5 1-2-inches, speed under load 1,000 r.p.m. It burns either kerosene or gasoline. The farm lighting manufacturers were well represented and showed considerable activity; brilliant illuminations at night were a distinctive feature of these exhibits.

The percentage of horse drawn implements shown at the C.N.E. is smaller each year, practically all of the manufacturers have gone in strongly for the production of power machinery. The exhibits of tractor-drawn implements were very large. Altogether the power farming exhibit was the largest and most inspiring of its kind ever seen at the Toronto fair.



The Samson Tractor Company is the latest addition to the Canadian tractor industry.

inspected these exhibits and took a keen interest in their function and operation.

The power farming section was bigger than ever and showed several new developments. The farm truck and the small thresher were big features and mark the trend in farming to a more intensive use of power machinery.

Those who expected prices in machinery to take a drop this season will be disappointed. In fact the prices in practically all lines show an increase over the prices quoted at last year's exhibition and if conditions remain as they are the trend will be higher instead of lower. The main factors which go to keep the price up of implements and automobiles, as every one knows, are the excessively high cost of raw materials, the increased cost and scarcity of transportation facilities and the high wages paid to the workers. Then in many parts of the country the demand for farm machinery, especially tractors, is way ahead of the supply. In Saskatchewan alone, in spite of the fact that the farmers have purchased tractors to the extent of \$6,000,000, this year, the dealers can't get enough supplies to meet the demand. So long as such conditions prevail there is very little prospect of prices coming down in the near future.

EVERY variety of tractor was shown; some hitched up to plows, cultivators, discs, etc., and some on belt work operating small threshers, silo fillers, corn shellers, etc. There are no new developments in tractor design although some of the manufacturers have added new features. For instance, the J. I. Case Threshing Machine Company is equipping its 10-18 tractor with a force feed lubricating system. The new Fordson is also being equipped from the factory with a Taco governor. That the tractor is being used on the road for haulage purposes is evidenced by the fact that there is now on the Canadian market an equipment for the Fordson, which transforms it into a haulage machine. The equipment consists of four extra wheels; the two front wheels are fitted with solid rubber tires and the rear wheels have slabs of rubber fitted around the

the light, the medium, and the heavy—all feel that their particular weight of machine is in most demand the farmers and the dealers very often had their own preferences. The I.H.C. and the J. I. Case Threshing Machine Company representatives stated that their small tractor was the one in general favor for all purposes.



Fordson equipped with rubber tire wheels for road haulage, seen at the Fair.





Some of the small threshers seen at the Toronto Exhibition—the small thresher is becoming very popular among dealers and farmers.

## The Small Thresher at Toronto Exhibition

THE outstanding feature in this year's power-farming exhibit at the Canadian National Exhibition was, undoubtedly, the fine showing of the small individual thresher. That the small thresher has come to stay goes without saying. Its development was logical and inevitable. Where is the farmer, after his crops have been cut, who has not waited for days consumed in anxiety for the old-fashioned threshing gang to come along? Regardless of weather or grain condition, or the pressing necessity of more important work, he had to take his turn or lose the opportunity of getting his threshing done.

The progressive farmer has become tired of such a system, and has gladly embraced this latest development in power-farming.

Just as the farmer took hold of the tractor so will he take hold of the individual thresher. And one point that was clearly demonstrated at the Toronto Exhibition was the fact that the small and medium sized tractors are quite capable of operating the individual threshers.

All of the machines shown were being operated from the ordinary farm tractor. It is quite obvious that a farmer who is a prospect for a tractor is a prospect for a small thresher. The dealer who sells the farmer his tractor stands the best chance of getting the cream of the thresher business, providing he goes after it. The manufacturers' representatives spoken to by M. T. I. were unanimous in stating that the thresher as built by reputable firms requires but little or no service.

The thresher can be sold to a community of two, three, four or more farmers, and that seems to be the

popular method in selling at present. The price ranges around \$1,500, which may seem to some farmers who have just purchased a tractor and other expensive machinery a little out of reach, but when the burden is being shared by a group of farmers the individual cost is negligible.

The production in small threshers since 1916 has increased enormously. In connection with one thresher company, according to a recent report, in 1916 less than one per cent. of its output was small threshers. In 1917 it was over 16 per cent.; in 1918, 64 per cent.; in 1919, 59 per cent. and this year small machines will constitute 65 per cent. of the company's production. Another company in 1916 did not build a machine smaller than 28 in. This year it will produce more than 1,000 20 and 22 in. sizes and all have been sold.

Implement dealers from all over Ontario inspected the small threshers and studied them while they were in operation. Doubtless they will go back to their work with the determination to add the small thresher to their line. It was the biggest display of its kind ever seen at the C.N.E. and drew around itself throngs of interested people from the implement store, the farm and even the city. In these days of farm labor problems and underproduction, especially of the necessities of life, every development in power that will mean a saving in labor and increased production should be gladly welcomed. Such machines will speed up production all along the line.

Small threshers were shown by the International Harvester Company, of Canada, Hamilton, Ont., Goodison Thresher Co., Ltd., Sarnia, Ont., J. I. Case Threshing Machine Co., Sawyer-Massey Co., Ltd., Hamilton, Ont.; The Robert Bell Engine and Thresher Co., Seaforth, Ont.; MacDonald Thresher Co.; George White and Sons, Limited, London, Ont.

## New Autos and Trucks at C.N.E.

THIS year the Transportation Building was given over entirely to automobiles. Trucks and accessories shared the twin demobilization armories to the west of the Transportation Building. Overflow trucks were housed under canvas. Though scattered, the automotive display was one of the most noteworthy ever held. There were several new models among the automobiles shown and one entirely new car. The cars were arranged tastefully and attractively around the four walls and in two hollow squares in the centre of the hall.

One of the new models which attracted attention was the new 1921 McLaughlin seven-passenger open car, known as the Master-Six. The engine is the valve-in-head type and mechanically the new Master-Six is a worthy successor to the previous models produced by this company. The Master-Six line for 1921 comprises seven new models—three open and four closed models.

Another new car was the Paige Lakewood seven-passenger touring car. This car is mounted on a chassis, new in one sense but thoroughly tested out in principle on ten thousand smaller chassis. The motor is six cylinder cast en bloc with detachable head: 3¾-inch bore; 5-inch stroke.

The lubrication is an automatic, adjustable, pressure feed by gear pump. Oil forced to crankshaft and connecting rod bearings. Camshaft, timing gears and cylinders lubricated by splash. The starting and lighting is the Gray and Davis separate starting motor fitted with Bendix drive. The Atwater-Kent high tension distributor ignition with automatic spark advance is used. The carburetor is a Rayfield and the clutch is Borg and Beck 12-inch three plate. The

(Continued on page 15)



# CANADIAN MOTOR, TRACTOR AND IMPLEMENT TRADE JOURNAL

Published on the fifth of each month by

The MacLean Publishing Co., Limited  
TORONTO, MONTREAL, WINNIPEG

JOHN BAYNE MACLEAN,  
President.

H. T. HUNTER,  
Vice-President.

H. V. TYRRELL, General Manager.

LONDON, ENG., THE MACLEAN COMPANY, OF GREAT  
BRITAIN. LTD., 88 FLEET STREET, E.C.

BRANCH OFFICES: Montreal, Southam Building, 128 Bleury  
Street; Winnipeg, 1103 Union Trust Building; Vancouver,  
314 Carter-Cotton Bldg., 198 Hastings St. W.; New York,  
Room 620, 1133 Broadway; Chicago, 405-6 Transportation  
Bldg.; Boston, 734 Old South Building.

SUBSCRIPTION PRICE—\$2.00 A YEAR.

OFFICE OF PUBLICATION—143-153 University Ave., Toronto.

Vol. 2 TORONTO, SEPTEMBER 5, 1920. No. 9

## A Vexed Question

**D**EALERS in many districts of Ontario are faced with a serious problem at present in connection with the sale of farm electric lighting systems. The difficulty does not arise because the farmer lacks interest in providing his home and buildings with electricity. He is thoroughly sold on the proposition and is anxious to have a clean, safe lighting system but, and here is where the trouble lies, he is waiting for Hydro power. Just why he should wait for Hydro is not quite clear. True, Hydro has been promised him; but when is a matter that may be asked of the four winds with about an equal chance of a definite answer. If the Hydro Commission would come out with a definite statement as to the districts they are likely to link up within a reasonable time and those which are impossible for them ever to touch, the farmer would know where he stood and the dealer would be able to proceed with his plans. As it is, there is a deadlock and until something is done the dealer will suffer in this particular branch of his business. The situation affects not only the sale of lighting plants in certain districts but also the sale of stationary engines. And, as every dealer knows, stationary engine sales bulk largely in the implement business. Farmer's Magazine, in an editorial discussing the question from the farmer's standpoint, says in part:

Premier Drury, speaking recently at Peterboro, intimated that the future of Hydro power was likely to be discouraging to farmers who were depending upon it for lighting and power. The immense cost of development work and the present limitations of power production, with the insistent demands from cities and manufacturing plants, were items that were affecting the outlook.

Another thing is discouraging to farmers. A new schedule of rates is being made and the vexed question of a proper division of costs between the commercial and rural routes has to be settled. If farmers could get the flat rate for the current that is possible where the users are many and the peak load more constant, they would be in a favorable position. But the fact that rural lines do not use power constantly and that they are all likely to call upon the service when it is running near the limit introduces questions which it will take time to settle.

The overhead costs for installation have been too high on many individual farmers and if the power is going to be as uncertain as it has been on certain lines this winter, many will be well advised to make arrangements for a private power plant if they wish to enjoy these advantages in the next few years.

Many farmers even in close proximity to the power development have decided to put in their own power plants and light their premises as well as operate their smaller power requirements by the same plant, while gasoline engine power at the barn, from tractor or stationary engine, proves cheaper than the electric. Many farmers will so see it this year. In fact, we would advise farmers not to wait for Hydro power if they can get a system where its installation equipment can be readily connected with the Hydro, if it should reach them in the next decade. The running of a radial line near by does not guarantee to ad-

jacent farms an early service. And in justice to the private inventions for power, it must be admitted that many are efficient with an overhead cost that is not at a disadvantage when compared with the Hydro.

## Bow to the "Power" Dealer

**I**N M.T.I. we have been, through our editorial pages, talking about the Power Farming dealer, the Automotive dealer, believing that the time was rapidly approaching when these two would be as one. That time has practically come. There have been countless articles written on the subject of who is the legitimate tractor dealer—who should sell the farmer his truck—his automobile—his farm lighting system. The old fashioned implement dealer is rapidly disappearing and a new man making his bow.

Any one who had the privilege of visiting the Canadian National Exhibition and viewed the farm machinery section must have been struck by the almost universal use power is being put to on the farm. The horse-drawn implements are becoming fewer each year and are confined to a certain limited class.

The advent of the tractor necessitated a new class of dealer. He was the Power Farming dealer. Now that the farmer is buying automobiles faster than any other class and the motor truck has appeared on the horizon the Power Farming dealer has become the Power or Automotive dealer. The new dealer is being formed from two classes, the automobile dealer and the implement dealer.

The progressive element in both classes is forcing the issue. In the cities and towns—outside of the very largest cities—the automobile dealer has been selling tractors and the progressive element mentioned above is selling farm lighting, stationary engines, cream separators, milking machines, etc. The implement dealer naturally was the first to handle tractors. The introduction of power into his business opened up a new field. In order to give the required service he had to study internal combustion engines sufficiently to keep his machines in smooth working order. The progressive element in this class seeing the farmer take hold of the automobile, the tractor and the motor truck, gradually extended his business until he embraced all these.

So, while we have in some districts automobile dealers who do not handle tractors and other farm machinery, and implement dealers who do not handle automobiles and trucks, there is gradually developing the "All Power" man—the Automotive man we have seen coming for a long time—from out of the two classes.

## Sell Farm Lighting by Demonstration

**P**RACTICALLY every implement dealer now handles farm lighting plants, and has had some experience in selling them. Without a doubt the best way to sell electric lighting plants is by giving practical demonstrations. In discussing the subject



HELP!

—“Morning Albertan”

of selling electric lighting plants the manager of the power and light department of a large electric company said to M.T.I. recently:

“Ten thousand Canadian farmers are anxious and willing to spend ten million dollars this year for electric plants and water systems, but they are not going to buy until the dealers show them just what they are to get for their money.

“Suppose ten years ago you had just taken up the agency for a car. There was none in your territory, and you had no demonstrator, and you figured that John Brown of Brownsville could afford one, and suppose some fine day you hitched up your horse and rig and drove out to see him, and told of this wonderful new machine. You told him that he could make the ten miles to town in almost the time he would be hitching up the old horse and rig and that he would be riding with the greatest of comfort, gliding along on tires filled with air, and that all he had to do was to sit up and “give her more gas,” and when he was through with his trip, it could stand in the barn for weeks and would not eat its head off in oats, and that he could take out the whole family, and of all the other wonderful things a car does. Don't you think that Mr. Prospect would say, “Yes, that sure is a fine machine, but I would like to see one before buying.”

“Yet there are hundreds of dealers in Canada to-day trying to sell lighting plants in exactly this way. They are talking about pushing a button and flooding the barn with light, and turning the switch and doing the family washing, and giving the farmer dozens of other appealing arguments, but he is not going to buy until you show him that ‘It can be done,’ and just as you do, he will buy.”

The manufacturers of lighting plants usually have demonstration trucks all fitted up to send out under competent demonstrators to “show the farmer how.” These demonstrations are of considerable educational value, but, in the opinion of some manufacturers, are not so effective in actual selling as the local dealer's own more informal demonstration.

By supplying the light for garden parties—those garden parties where the local member for parliament is being entertained and where the farmers for miles around attend are sure prospect getters. There are many ways in which the dealer can get publicity and an interested audience without the appearance of actual advertising. Such demonstrations are by reason of their informal nature the most effective.

Therefore, Mr. Dealer, have your demonstration outfit and be ready at all times to catch the prospects on the wing, so to speak.

## Keep Advertising

**J**UST because a company, or dealer, or branch house is sold out is no reason why it should quit advertising. When you stop advertising, all that you have done before begins to crumble and the time will come when you are not sold out and when you will need the power that is built up by advertising. A continuation of advertising continues this force and keeps it ready for emergencies.

If you are sold out it merely means that you can be more careful about your advertising and direct your aim better than when you are in a hurry and greatly need its immediate effects. If you haven't anything to sell you can continue to sell the public on your name and keep it from forgetting what a fine company or dealer you are, what good products you handle and how honestly and efficiently you do business. You can use the over-sold period to sell the public on your policies and purposes in being in business.—The Harvester World.

## Ontario Headlight Law

**T**HE Headlight Anti-glare Law for the Province of Ontario is expected to become effective about the middle of September. The work of examining headlight lenses and other devices for the elimination of glare has taken longer than anticipated. Professor Lang, of Toronto University, is superintending the inspection of devices and he expects the list of acceptable devices will be complete within the next few days. As soon as the list is complete and has been published the law will immediately become effective.



# Selling Implements by Human Appeal

## This Implement Concern Sells Machinery by Making Friends Through The Service Department

**T**HE implement and power farming dealer who 'sticks around' his store these days gets nowhere. To make a success of this business a man has to get out and hustle; and his hustle has to be no blind rush either. In our own business we make it a strong point to know our prospects. We try to make friends everywhere we go, and this necessitates a close study of every prospect we come in contact with."

The man who delivered himself of the foregoing was J. A. Wilson, of the Wilson and Hubbs farm implement concern of Belleville, Ontario. This concern although only a year old is as fine an implement organization as there is in Eastern Ontario. Both partners have had wide experience as salesmen and both were born and reared on a farm. Mr. Wilson, in discussing his business with the M.T.I. representative, expressed himself of the opinion that the man selling farm machinery who has been reared on a farm has a distinct advantage over his town or city born competitor in that he has inside knowledge of the farmer's conditions.

The partners each have their separate duties; Mr. Wilson is the salesman and Mr. Hubbs is in charge of the office end of the business. With this arrangement a salesman can be out on the road all the time.

"**W**E believe in canvassing," said Mr. Wilson. "It seems to us to be the only way to sell farm machinery. It may seem a surprising thing to say, but there are labor saving machines on the market to-day which are unknown to many farmers. Some farmers in our experience have stood amazed when we introduced certain lines to them. While it is true that the average farmer to-day is a reader there are a great many who do little or no reading. It is a mistake therefore to presume that every farmer is aware of all the important labor saving machines that are on the market. It seems to us then that canvassing is the one way to make sure, and the best means of educating all the farmers.

"Then coming into personal contact with prospects at regular intervals gives us an opportunity of studying them on their home ground. We try to make our calls as informal as possible. It isn't good business to let a farmer think you have come to see him for the single purpose of selling him something. The farmer is conservative and very much afraid of being 'stung.' So it is best to make friends right away and the only way to accomplish that is by taking a real interest in him and his problems.

"**W**e talk to him about his problems and sell our machines from that angle. We sell something to solve a problem, something that will make his work lighter, do it quicker and produce greater profits. Of course we send out letters and advertising material and have found it is profitable to do so, but such material is read only by the more progressive farmers. The non-readers I spoke of absolutely ignore it. The most effective way to use advertising material is to follow it up closely by a personal canvas."

Mr. Wilson is very enthusiastic and has a lot to say about selling farm machinery. He loves

the game—as he calls it—and from his earliest years longed to sell something. Before he entered into partnership in his present business he was a salesman for another concern for some years. While with this concern he got considerable experience in the farm implement field both inside and out on the road. Mr. Hubbs, his partner, has also been a salesman for many years and has had wide experience in selling to the public.

Their warehouse is located on the principal street in the heart of the business section. It is 30x100 feet and occupies the ground floor. They carry a large stock of machines and have them arranged in a neat and accessible manner and all assembled

facultly. Theoretically it seems an impossible task but in reality it is a simple matter indeed. Farmers are becoming educated more and more in the care and operation of machinery and the dealer's task is consequently getting lighter. There are still, however, a great many service calls and the dealer who handles such calls promptly and effectively is the man in whom the farmer puts his trust.

"**W**E never neglect a call for service whether it is in connection with a machine we sold ourselves or one sold by a competitor. We have made a lot of good friends, resulting in many sales, simply by giving a man good service at a critical moment.

"We had a telephone call from a farmer one day asking us to help him fix up his binder which had broken down while being operated at a busy time. This binder had been sold to the farmer by a competitor who refused to give the service when asked to do so. We went out and saw the farmer out of his difficulty and were informed by him that on account of his not purchasing all of his equipment from the dealer who sold the machine the service was refused. He buys everything from us now and through him we have been put in the way of numerous new prospects which led to sales.

"We are thoroughly convinced that this business is built up on service. Whether service is given free or charged for it should be given to satisfy. Satisfaction is a sure guarantee for future sales and greater profits. We have even found it profitable to give service when it cost us money to do so. We made a good customer out of a man some time ago by rendering him service on a machine, which we did not sell to him, and charging him only for the parts use in the repair."

Wilson and Hubbs have a very fine territory of about 40 square miles. It is bordering on Hastings and Prince Edward counties and is one of the richest mixed farming districts in eastern Ontario. There is a big market for all kinds of farm machinery.

Wilson and Hubbs handle everything connected with power farming. On their floor can be seen at any time practically every implement or machine used on a farm.

**T**HEY believe there is a big future for the small thresher in their district. Just as the farmer has taken hold of the tractor so will he take hold of the small individual thresher, and in the very near future. They have already sold a few threshers and are looking forward to big sales.

They are having some difficulty in selling farm lighting plants because the farmers are holding off, waiting for Hydro. The farmers in their territory are anxious for electricity and have an idea that they will soon have Hydro. Nobody knows, in Mr. Wilson's opinion, just where they got this idea, except that Hydro has been promised them some day, but whether that day is separated from the present by one year or twenty no one in the district has the

Continued on page 30



This picture shows Wilson & Hubbs' implement store. Notice the signs indicating some of the lines they handle.

ready to be shipped. They aim to have in stock at least one sample of all the goods they handle. When seen by M.T.I. they had about twenty thousand dollars worth of machines and about seven or eight thousand dollars worth of parts on hand.

There is a special room where repair parts are kept. They are arranged in boxes around the room, each box ticketed with name of part and number. One section is devoted entirely to plow parts and another section to tillage and harvesting parts. In this way confusion is avoided and parts readily got at.

"**W**HEN we sell a man a machine," said Mr. Wilson, "he has the assurance that we are in a position to take care of all his service requirements. If there is a breakdown anywhere we can supply the necessary repair parts and have it fixed within a few hours of receiving the call for help. The advantage of such service to a farmer in the height of his busy season cannot be over-estimated. Our reputation for prompt service is one of our best advertisements.

"Selling farm machinery and selling service are synonymous. The two are inseparably bound together. When a man buys a machine he must be looked after. He must be educated in the operation and care of his machine and helped out of every dif-



# Demonstrations Will Sell Your Tractors

HOW many people do you know who bought their automobiles without having a demonstration

of the particular kind of car which they bought? Not very many, if any. It does occasionally happen that a person will buy a car entirely on its reputation and without ever having ridden in a machine of that particular make, but these cases are comparatively rare—usually the purchaser wants to take a little spin and see for himself how the machine rides, how much power it seems to have for hills, and “get-away.”

In spite of the fact that automobiles are very largely standardized and are no longer a new thing—in spite of the fact that the purchaser is reasonably sure that the machine he is considering buying is a good one and will be reasonably satisfactory, inasmuch as he usually knows that similar cars are giving satisfaction to thousands of other users, he still wishes to try it for himself.

And yet a great many tractor dealers seem to think that a farmer should be willing to buy a tractor merely on the claims which he and the manufacturers make for it, and without having an opportunity to see the machine actually at work under the conditions found on their own farms until after the order has been signed.

Not all dealers take this attitude, however, and it is probably safe to say that the best dealers do not try to sell tractors on this basis, but make a practice of demonstrating their tractors to prospects just the same as an automobile salesman demonstrates his car.

If the automobile in its present state of development and general use is still sold principally by means of demonstrations to the prospects, it would seem obvious that demonstrations of tractors would also be valuable sales helps.

**D**EMONSTRATING tractors is not a new thing. A number of large national tractor demonstrations and countless smaller ones have been held all over the country, sometimes by an individual dealer, or by the dealers of a county or town.

The large tractor demonstration where a hundred or more machines are all at work in the same field is of questionable value, because such demonstrations tend to cause confusion in the minds of the farmers who visit them, but there is a very important place in the tractor industry for tractor demonstrations of the right kind. Which kind will be the best for any particular dealer might be an open question—it may be the one where several local dealers put their machines in the same field and give a semi-competitive demonstration, at which the farmers of the neighborhood have an opportunity to judge as to the relative merits of the different makes of machines sold by dealers in the community for the particular conditions there found. It is obvious, however, that this sort of demonstration is likely to be of the greatest benefit to the dealer whose machine makes the best showing, provided the price is right and other things are equal.

Another type of demonstration which has been used to excellent advantage in numerous cases is one held by the individual dealer, and to which the farmers of the neighborhood, or such of them as the dealer considers good prospects, are invited. In this way the dealer is enabled to show his machine at work to a large number of farmers at one time, and thus reaches individual prospects at a minimum cost.

Still another type of demonstration has been found profitable by a great many dealers. This is one which is given on the farm of the prospect, without the prospect signing an order or assuming any obligations whatever—the dealer believes that the prospect really needs a tractor and that he can take a machine to the

By **ARNOLD P. YERKES**

farm and demonstrate to the farmer's satisfaction that the outfit is practicable and profitable for his conditions, and proceeds to make such demonstration. In some cases this sort of demonstration will be made by a machine which the dealer keeps for this purpose. In other cases, the machine used will be a new one and the prospect buys that particular machine, in case a sale is made.

**S**OME dealers take the attitude that they cannot afford to make a tractor second hand by keeping it for use only in demonstrations and later sell it at a reduced price because such use has made it a second-hand article. Other dealers, however, believe that this is the best and most satisfactory method, as all the machines in stock are then brand new, and if the prospect can be induced to sign an order a new machine is started up and delivered to him. The practicability of these two plans of course depends upon the number of machines which the dealer sells. Keeping a machine specially for demonstration purposes is profitable only where a number of sales are made.

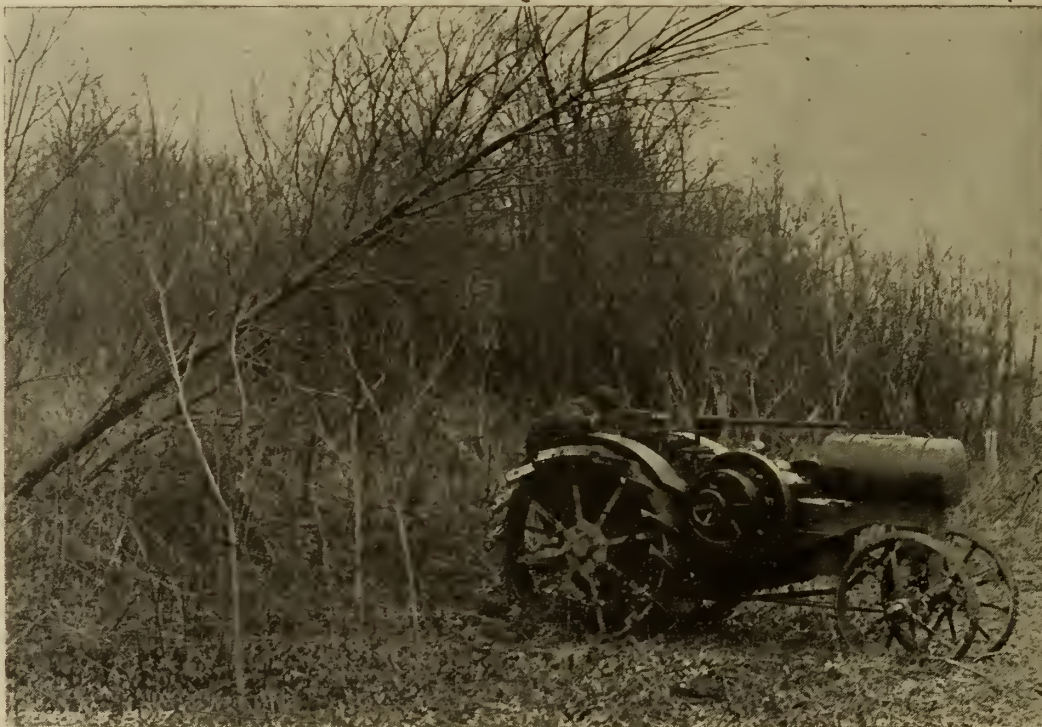

The odd jobs which tractors do on various farms are very numerous. Here is one employed advantageously clearing up brushland.

**T**HERE is yet another type of demonstration which is frequently practised, namely, that of having a customer demonstrate his machine for the benefit of prospects—either for a single individual or several at one time. This method has certain advantages inasmuch as it demonstrates to the prospects the fact that a neighboring farmer has bought the machine, learned to operate it satisfactorily, and is able to do good work with it. However, this kind of demonstration savors too much of the days when automobile dealers followed the same practice, that is, they bought no car of their own to be used for demonstration purposes, and after they had made a sale they depended upon that customer for demonstrating the machine to other prospects. It has not been so very many years ago since this was a very common practice in the automobile business, but as the volume of business increased the automobile dealers found that this practice was not as satisfactory as giving their own demonstrations. Furthermore, the fact that a dealer was willing to buy a machine of his own to be used largely for demonstration purposes gave added confidence to the prospects.

The same objections as in the case of automobiles hold against this type of demonstration so far as tractors are concerned. It indicates to the thinking farmer that the dealer does not have a great deal of confidence in his ability to sell the machine, and pro-

bably in the machine itself—otherwise he would keep several in stock and be prepared to give his own demonstration.

It is far better for the dealer to have on hand at least one machine which he can put in the field and show its capabilities rather than to depend upon using a machine already sold.

But, regardless of the particular kind of demonstration which the dealer wishes to give, there are certain points which should be carefully observed in order to avoid having the prospects receive an unfavorable impression of the tractor.

It is not at all uncommon, at tractor demonstrations, to see a very poor quality of work done because the plow has not been properly polished beforehand and is out of adjustment, improperly hitched, coulters not set right, jointers not provided, or for some other cause which could have been overcome had proper precautions been taken. Nor are all failures to give a good demonstration confined to the plow. Quite often the tractor will be in the hands of a green operator or one who, while he may be entirely competent to adjust and repair the tractor, has had so little field experience that he is incapable of doing a first-class job of plowing or other work in which he may be engaged.

Then there are a great many small details which are often overlooked, but which serve to give the visitors an unfavorable impression of the outfit. It may be a lack of cooling water, due to the carelessness of the operator. Perhaps the clutch on the new machine has not been properly adjusted and begins slipping, causing delays and trouble. A list of the minor details in adjustment of the tractor and equipment which have been responsible for poor showings in tractor demonstrations would fill the page. Yet nearly all of them could have been prevented by a little more care and thought on the part of the operator or whoever was in charge of the demonstration.

**A** POOR showing at a demonstration is worse than no demonstration at all. When a person attends an advertising demonstration of a machine he goes with the idea that the outfit will be in the hands of experts and that the showing which it makes will

be the very best of which it is capable. This feeling is only natural, as no one will expect a business man to advertise a demonstration of his product at which he would permit the outfit to make an inferior showing. Under such circumstances, if a tractor fails to deliver its full power because of misadjustment, poor fuel, or any other cause, or time must be spent by the operator in fussing with and adjusting the outfit, the impression made on those present cannot be as favorable as when everything runs smoothly and without a hitch—they naturally feel that such difficulties are the invariable accompaniment of tractor operation or that they would otherwise have been avoided.

The tractor dealer should fix these points in his mind: first, that well-handled demonstrations are excellent sales helps, and second, that if the demonstration is not to be a good one it is better to have none at all. Before attempting to put on a demonstration, therefore, the wise dealer will take every possible precaution to insure having the machine make a creditable showing.

It is impossible to give suggestions covering all the details which must be considered. First and foremost, of course, is the necessity of having a competent operator and one who not only can handle the tractor well but who is also capable of doing a first-class job of plowing or whatever kind of work he is supposed to demonstrate.

Next in importance is the proper adjustment of the



entire outfit, both tractor and tools. This usually means that the machine must be operated in the field previous to the day of the demonstration in order to insure having everything working first-class. A preliminary trial of this kind will determine just where the rolling coulters of the plow should be set, whether a jointer is desirable, the proper hitch for the depth at which the plows are to be set, and all such details.

The mistake should never be made of taking a brand new plow into the field and attempting to make a good demonstration with it before it has been polished up and properly adjusted. A great many farmers judge the quality of the tractor by the work done by the plow which it pulls. This is, of course, a mistake but since it is a fact the dealer should make every effort to have the plow do as good work as possible. The necessity for taking the precautions referred to are, therefore, obvious.

The old adage that "if it is worth doing at all, it is worth doing well" applies very forcibly to tractor demonstrations. This is not merely theory, but has been abundantly proved in actual experience by tractor dealers all over the country. The best results from tractor demonstrations have been obtained by the dealers who have their machines make the best showing.

# Make Utility the Keynote of Your Sales

By B. J. PAULSON

THERE are two ways of selling farm implements:—selling them either just as implements, or as farm utility equipment. The one is a matter of taking orders while the other is a little study in salesmanship. When you sell a customer an implement and nothing more, you can just bet your last dollar that you are supplying him with something that he wanted and had already made up his mind to buy. But when you sell the customer an implement or machine that he needs, but which he doesn't know he needs, then you are selling him something on a utility basis. To illustrate:

Let's suppose you are a dealer who sells implements just as mechanical tools. Farmer Mangus MacGregor, who owns a good-sized farm, comes in to buy a new walking plow. All right, you sell him the walking plow—and let it go at that. You are selling him an implement as an implement, and nothing more.

Now on the other hand, let's suppose you are a "utility equipment" dealer. When Mangus MacGregor comes in and asks about a walking plow you give him all the information he wants about this particular plow, but, at the same time, as you happen to know that Mr. MacGregor is pretty well fixed both financially and in the matter of land and know that a tractor plowing outfit would prove of much greater utility on his farm than his walking plow, you adroitly proceed to turn his thoughts from the little walking plow to a power-lift tractor plow and a tractor. You explain to him the comparative utility of the two. You appeal to his sense of thrift and economy by explaining to him how a 10-20 tractor and a three-furrow plow will accomplish as much work in a given time as four men with single-furrow walking plows or two men with gang plows, and will work at about one-half the cost of horse operation—no feed for the tractor when it isn't working. You appeal to his sense of acquisitiveness by showing him how, with a tractor outfit on his farm, he will be able to plow, plant and harvest a greater acreage than would be possible otherwise and that he will derive a greater profit from his crops because of the fact that the tractor outfit reduces the farm operating expense.

IF you are a good salesman you probably will succeed in convincing Mr. MacGregor of the much greater utility of a tractor outfit, for his particular needs, than a horse walking plow. And when he becomes convinced that the saving in labor and horse feed, plus the increased acreage and proportionately increased crop production resulting from tractor operation will more than offset the difference in price between the tractor outfit and the walking plow—when you convince him of this, he is as good as sold.

And thus, by selling him this outfit on the farm utility basis, you make a large sale instead of a small

THE best results, however, have not always been obtained easily. In a great many cases the dealer has gone to considerable trouble to insure having the demonstration show the best results possible. There is a story of one tractor dealer who, before attempting to sell a single machine, spent six months with the tractor which he intended to handle, working it on the farm and learning every detail of its operation and of the machines which it pulled. He did this so as to be prepared to answer any and all questions which prospects might ask and to be able not only to tell them but to show them what the tractor could do. He gave lots of demonstrations and they were run almost without a hitch. The results were all, or probably more than could have been expected, and well repaid the time and trouble which had been spent in acquiring the degree of proficiency necessary to give such demonstrations. This dealer is credited with having sold more tractors than any other ten tractor dealers in his territory.

The fact must not be overlooked that farmers today give the matter of service a good deal of consideration and that it cannot help but have a favorable effect on tractor prospects when they see the dealer operating a tractor in a competent manner, able to make adjustments instantly, and to keep the machine in first-class working order. Any thinking farmer

would prefer to buy a machine from a dealer of this kind in preference to one who was poorly informed concerning the outfit which he handled and who depended on hired help to operate his machine in demonstrations and to make adjustments and repairs which his customers might require.

Some dealers feel that it is not incumbent upon them to handle the tractor in their demonstrations. There is a certain psychological effect, however, in having the dealer operate the machine which should not be ignored. The farmer knows that the dealer will always be on the job, but he has no assurance whatever that a hired mechanic, no matter how good he may be, will remain in the service of the dealer for any length of time. Unless there is some excellent reason, therefore, why a tractor dealer cannot operate the tractor personally, it will nearly always be found advantageous for him to give his own demonstration, at least in large part. It may be desirable to have some one else ready to assume charge of the tractor after considerable work has been done, in order to give the dealer time to talk to prospects and explain various features of the machine or its work. But the advantage of showing the prospects that the dealer himself is perfectly capable of operating and caring for the tractor and knows how to make it do first-class work is too great to be passed up.

one, and by so doing increase the customer's farm operating efficiency and chances for future prosperity, because of the farmer's increased buying power. As you increase the customer's buying power, so will you also increase your selling power. And "utility equipment" is the trick that will do it.

PRACTICALLY all new farm machines and implements must be sold on a utility basis—the work that they can accomplish and saving they will effect in time, labor, money. The stationary engine is a good example of farm equipment that must be sold on this basis. If you leave it entirely to the farmer, you won't sell many engines. The average farmer has been getting along without an engine all his life—and his father before him got along without one and seemed to come through all right. You've got to convince the farmer of the great utility of an engine on the farm before he'll buy one. You've got to show him what an engine will do for him—how it will pump water for the livestock during cold winter days and the hot days of the harvest rush when every minute is precious and the wind-mill becalmed, as it often is; how it will take the hard work out of sawing wood, shelling corn, turning the grindstone; how it will conserve the strength of the women folk and give them more leisure by operating the washing machine, churn, and cream separator; how it will earn money for the farmer during odd days between seasons by operating a feed grinder, grinding feed not only for himself but for his neighbors—at a good profit.

As a result of this "utility education" the farmer discovers a necessity that he did not realize existed before—and the necessity is an engine. And after he buys the engine he discovers other "utility necessities" needed to make the engine most effective—a pump jack, power corn sheller, feed grinder, power wash machine, buzz saw, etc. The dealer, by selling the engine, starts a chain of future sales that may even include an air pressure water system for the home or a farm electric lighting plant. One thing leads to another, for an engine, like a tractor, is a progressive machine that promotes a march of progress on the farm—each has a long list of belt power machines waiting to answer the call of willing power.

Machines and implements which the farmer has used and with which he is thoroughly familiar do not require "utility" salesmanship but there are a great many that do. For instance, every farmer is sold on mowers, and hay rakes but there are many who are not sold on the side delivery rake, sweep rake, tedder, loader and stacker. These items must be sold on a utility basis. Every farmer is sold on farm wagons but how many will you find, comparatively speaking, who are doing their farm hauling

by motor truck? Here again we meet the problem of utility—the superior utility of the motor truck as compared to the lesser utility of the wagon. In the same way we can go on down the line—cream separators, stalk cutters, potato diggers, potato planters, feed grinders, manure spreaders, fertilizer drills, corn huskers and shredders, corn pickers, ensilage cutters, hay baling presses—each of these must be sold on a utility basis if the dealer is to sell a profitable volume.

Most of the present-day farm implement advertising where implements not in general use by all farmers are concerned is designed to sell the farmer on utility performance—what the machines will do and save for him. But advertising alone cannot sell implements—the dealer must do the actual selling. Therefore, it's up to him to cook up a mess of good utility arguments and serve them hot to customers who don't know that they need machines that they really do need. That's all there is to it.

## New Autos and Trucks at C.N.E.

(Continued from page 11)

wheelbase is 131 inches; standard tread 56 inches.

The new Packard model is very attractive. We hope in a later issue to give a more detailed account of this model. Specifications were not available at time of writing.

One of the sensations of the motor show was the new "La Marne" introduced by the Anglo-American Motors Ltd., Toronto. This is an entirely new car containing many new and startling innovations. It won't be under production for some time as a factory has yet to be built. It has an 8 cylinder vertical type motor, 3¼-inch bore and 5½-inch stroke; 33 horsepower. The wheel base is 132 inches, the length overall 17 feet 6 inches and weight 2,900 pounds. It is expected that the price will be about \$3,000. We will give further particulars of this car also in a later issue.

The new four-thirty Briscoe shown, in finish and equipment, is a credit to the manufacturers. The Briscoe motor is four cylinders cast en bloc, L-head type, 3 3-8 by 5-inch stroke. The car has a tilted radiator giving a straight line drive from front bearing to the rear axle. The new Briscoe is finished in blue with upholstery in long grain leather.

Among the trucks the one adapted for farm use was specially featured. All the big manufacturers in this line were represented by several models. It was noticeable that the pneumatic tire is now becoming almost universal as truck equipment. Many and wonderful were the self-dumping and emptying devices. Passenger trucks, farm trucks, trucks adapted for city use and many others were found in the exhibition.



# What the Truck Salesman Should Know

## Knowledge of Fixed Charges, Maintenance and Operation Costs Vital to Success of Truck Industry

NOT long ago the writer met the owner of several large trucks used in hauling milk and other products to an urban centre. This man was quite boastful about the business he was building up and the profits he was making. Some doubts were raised, and in proof of what he said the truck owner granted the privilege of making an actual analysis of his truck costs as they were to be found in his accounts. It was found that he made no systematic allowance for fixed and maintenance charges, and when these were deducted from his gross revenue he was just breaking even. He had room to boast about the business he was doing, but it did him no good because he was serving the public for nothing.

In the above instance, the owner was more fortunate than many others who have found that after several years it is necessary to replace the old, worn-out trucks and they had not the funds with which to do it.

When a situation of this kind becomes general it gives the motor transportation industry a great setback. The multitude of failures among motor truck operators in the United States two years ago was a direct result of meagre appreciation of truck costs, especially fixed charges. The majority of truck owners know their gasoline and oil mileage and their drivers' wages, but very few give any thought to fixed and maintenance costs. They frequently fail; and when the salesman calls upon them again he will usually find that not only these men but their friends are poor prospects for further sales. Salesmen do their business and the whole motor transportation industry a great injury by selling trucks to men who they know have not sufficient knowledge of cost keeping or enough freight to haul to pay all costs.

Complete truck costs should be recorded for three reasons:

(a) To compare the entire cost or any item of the cost of operation of one truck with that of another truck of the same capacity in the same class of work, and in the same locality.

(b) To compare the cost of motor transportation with the cost of other methods of freighting.

(c) To determine the rates to be charged when the truck is used in public haulage.

There is not a fixed cost for any capacity or kind of truck. Every truck must be considered separately, and its economy of service must be determined from its own record of operating costs.

IN the second instance complete truck costs should be recorded in order to compete intelligently with other transportation agencies. While railway and steamship costs are usually reckoned only from terminal to terminal truck costs generally cover the entire cost of delivery from consignor to consignee, therefore in comparing railway and truck costs the former should include terminal expenses, extra crating unnecessary for shipment by truck, and the weight of extra crating. In a similar manner, horse and motor transportation should be compared.

By D. R. COWAN, M.A.

To sell trucks intelligently demands a thorough knowledge on the dealer's part of the product he is handling and of the conditions of his prospect's business. The dealer who KNOWS is the man who will succeed. He must be able to SHOW the prospect where truck transportation will be an asset. In order to do this he must have a thorough understanding of fixed charges, maintenance and operation costs and insurance. The salesman must put himself in his prospect's place and ask himself what he would expect of a truck if he were buying it. The necessity for study is at once apparent when the dealer applies this test. The following article was specially written for M.T.I. truck dealers by D. R. Cowan, M.A., who has made a special study of motor truck transportation. It will help the dealer to a better understanding of this all-important subject.

Thirdly few truck owners can succeed in hauling goods for profit if the real cost of operating the trucks is unknown. The entire cost of doing business, plus the desired profit, must determine the price or rate at which the service will continue to be rendered.

The monthly record of the operating cost of a truck should be made in three divisions—operating charges, maintenance charges, and fixed charges. Operating charges should include such items of cost as gasoline, oil, grease, current, driver's wages, and similar items which vary in direct ratio to the amount of use which the truck is given. They are properly called operating costs.

Maintenance charges should include expenditures for the upkeep of tires and truck equipment. Their amount depends as much upon the way in which the truck is used as the mileage. A careless driver will

cause maintenance charges to rise so rapidly that they will be out of all proportion to the actual work done.

Fixed charges should be made up of fire, liability and collision insurance, interest on investment, and depreciation of equipment. These items are most likely to be overlooked by the inexperienced motor truck owner.

In general there are five distinct kinds of motor truck insurance:

1. Liability.
2. Collision.
3. Fire.
4. Theft.
5. On Goods Carried.

Of these the most important is liability insurance and it falls into two classes:

(a) Insurance against injury to persons, and (b) insurance against damage to property. The first class protects not only the owner of the truck but also the driver against the payment of damages up to a certain amount for injury to persons. The second class covers damage done by the truck to another person's passenger car, truck, buildings, or other property.

COLLISION insurance only covers damages sustained by the insured truck and does not cover damages inflicted. This distinction should be kept clearly in mind when purchasing truck insurance.

Insurance against fire and theft is obviously necessary if the business is to be removed from the realm of speculative enterprise.

On liability, collision, fire, and theft policies the rates are determined according to:

1. The class of business.
2. The cost of the truck and its age.
3. The particular business in which the truck is used.
4. The particular locality in which the truck is operated.

Insurance on goods carried may be either blanket insurance on all goods carried during a given period of time, or insurance on a certain load at a particular time. Blanket insurance is highly desirable for public truck haulers but is difficult to obtain. The general reputation of the applicant often determines whether he will get it and what the rate will be.

Trucking, like any other business, has its risks. The cost of carrying these risks is a necessary and legitimate charge which should be included in the operating costs of the motor truck. The up-to-date operator will insure his business.

Of all the items which should be considered in calculating the cost of giving a trucking service, the interest on the truck investment is the one usually neglected by the small truck owner. It may equal the cost of lubrication or even repairs when the truck is new.

At present, truck owners use two methods in calculating the interest on the investment. One method is to charge 6 per cent. each year on the original investment.

Continued on page 35



GETTING INTO HIS STRIDE.



# ROSENHEIM and the Bulls and Bears

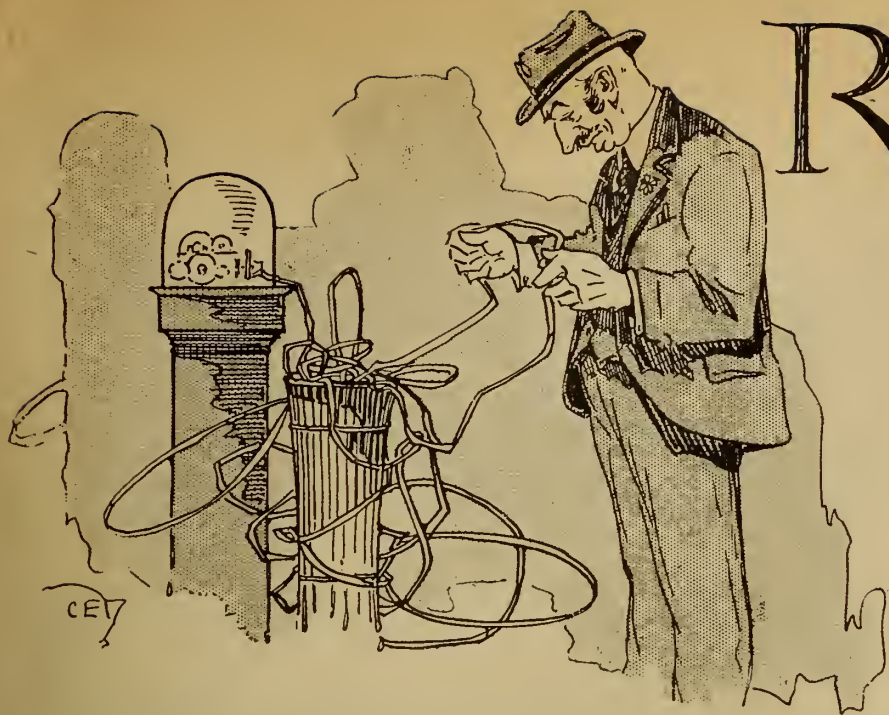

Pinched (With Permission) From "Timken Magazine."  
Sketches by CLYDE E. DARR.

"WELL, I see the market is up six points again already," remarked Meyer Goldman to his friend Max Rosenheim, proprietor of the Scotch Woolen Mills Emporium, High Grade Men's and Boys' Clothing.

"So it is, Meyer," replied Max, "also the thermometer is up eight points, which interests me a lot more seein' I have an A number one line of Panerma hats and Palm Beach suits."

"All the same, Max, them fellers in Wall Street make a lot of money out of the stock business."

"Sure they do, Meyer, otherwise, you understand, they would have jobs in sumpin' else. But they don't make the money off of each other. The fellers on the outside pours their money into the stock market and the brokers pass it back and forth like a football. If you ever talk to a broker or get one of his, now, reliable market letters, you allus notis that he is op-

Moe Bernstein, Sol Bernstein's oldest boy, who has been away for five or six years. The world seems to be treatin' you all right, Moe. What are you doin' for a livin' anyway?"

"You mean who, not what, don't you, Meyer. Me and work never agreed very long at a time, believe me, and in these times the pickin' is so good that it'd be a crime to do any real work. In New York I work for a while in a broker's office till I learn the ropes, and there I get wise to the fact that a feller is a boob to let his muscles or his head ache knockin' a livin' out of the world. And I want to tell you that I got the stock market eatin' right out of my hand."

"What is it I tell you, Max," said Meyer. "Here is proof of what I say. Here is little Moe Bernstein what used to loaf around here and we predict he will never amount to nothin.' And now look at his clothes and diamonds."

"It looks that way, Meyer," said Max, rubbing his chin thoughtfully. "Me, I ain't sayin' there ain't money to be made in the stock market. I'm allus ready to admit that. But you gotter admit that it is the suckers what buys the brokers' limmerseens."

"Say," remarked Moe eagerly, "are you two interested in the market? If you are, don't you fall for any of the phony stuff like thirty-day puts and calls, or ten-point margin on stocks that don't vary three points in three months, where you pay commission and interest and then have to sell out about where you bought. Listen to little old me if you want the real stuff. I'm wise to all the inside dope. I know what the insiders, the big fellows, are doing. I can send a wire to certain parties in the big burg and in an hour can get information that is right on any security listed on the exchange."

"Well, why don't you go right along and get rich?" inquired the cautious Max.

"I'm going to, I can let a limited number of my old home town friends in on it. Now, see here, if you two are in earnest I can wise you up to a killing that is due within the next three months. It was bein' cooked up when I was in that broker's office and it is about ready to be served. Are you game?"

"What do you say, Max? Shall we take it the chance?" asked Meyer, and the eager light in his eyes showed a desire to embark in the fascinating game.

"Ordnarly," said Max, "I should say no. But seein' Moe here is an old friend and has got reliable information, I don't consider it so much of a gamble. It's just as I was a tellin' you, Meyer. The mistake is when a sucker trusts to his own judgment. Now, Moe, what is the propersishun?"

"It's this. Sure no one can overhear us?" and he looked furtively around.

"Oh, it's all safe," said Max, but he moved over and closed the door. Then the three pulled their chairs closer together.

"It's Holdfast copper, a new mining proposition that has just been listed. It's selling now around twenty-five, but it's being manipulated and is due to ride to seventy. Then comes the big blow-off. The insiders unload and the public has the stock at the

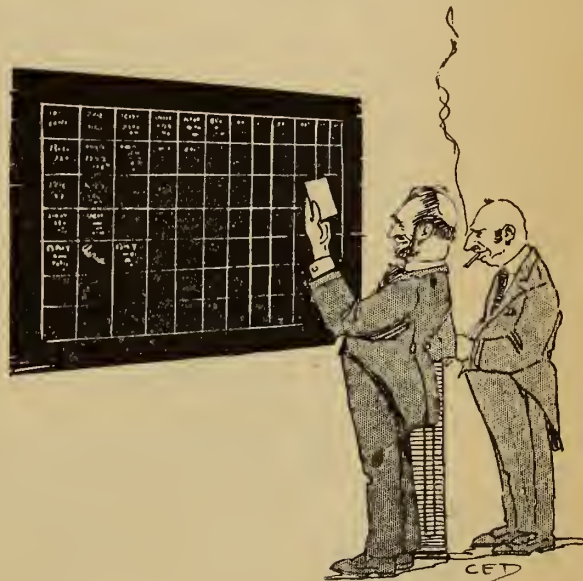

termistic, predictin' a great Bull movement and advisin' buyin' heavy on symperthetic reactions. And no matter whether you buy or sell a stock the broker gets his commishun, with added interest on the amount not covered by your margin, and another eighth on sales less than one hundred shares. You may win some of the time and lose some of the time, but the broker wins all the time, unless he hypnertises himself that one of the sure things he is handlin' out advice on is really a good thing. Then he goes broke just like any other sucker, only quicker. Wall street, Meyer, has a graveyard at one end and a river at the other, so it don't make any difference which way you go, the finish is allus goin' to be the same."

"Yet I have an idea in this here stock business," began Meyer, when he was interrupted by the entrance of a young fellow dressed up to the minute, who rushed forward with outstretched hand.

"Well, well, if it ain't Meyer Goldman as nacheral as ever, and Max Rosenheim, the greatest merchant that ever made Main street sit up and take notice. Greetings, and how is every little thing?"

"Well, well, Max, do you see who it is? Little

top price. Now I know all the inside plans. If we buy at the market to-day and hold for the top price, we make only about fifty points. If we margin two thousand shares and get out at the high figure, however, we make only a hundred thousand dollars, which ain't a real killin' at all."

"If you ask me I think a hundred thousand is a fair profit for a few months' investment," said Max.

"Oh, it's a fair bunch of coin. But what's the use of piking on a sure thing. Here's the ticket. This stock ain't going to jump to seventy over night. The insiders don't do business that way. It will jump ten points up, and then down she will go 5 or 6 points. The suckers will get scared and sell short.

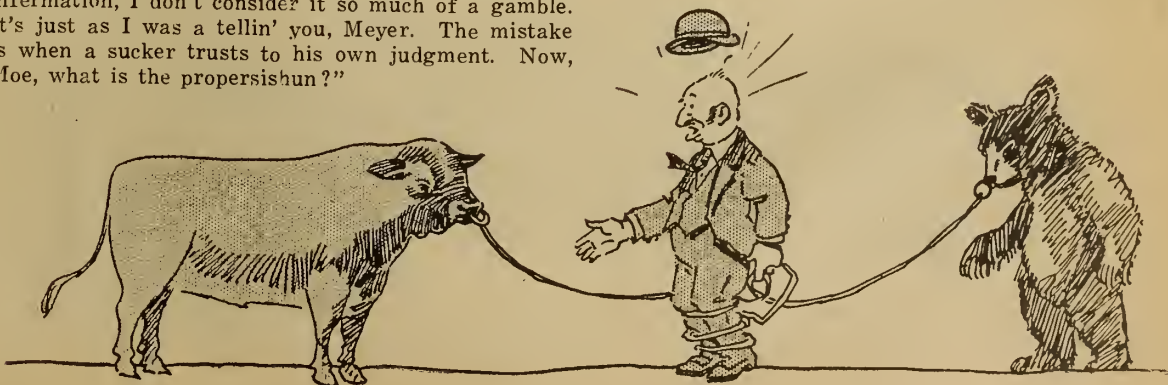



Then the wise guys will bull the market and shake the shorts loose. Up she goes fifteen points. What we do is to sell on a good substantial rise. Then we go short on the market and clean up on the reaction, then we buy in again, and margin more shares with our winnings."

"But, Moe," said Max, "ain't it just as you said we are suckers when we sell short? Ain't we doo to get that shooeking down?"

"Not at all, because I am on the inside and know when to buy and when to let go. Now I tell you frankly I ain't got the money to swing much on this deal. I got quite a lot of capital but it's tied up on a long-pull speculation and if I close now I lose, but by holdin' on for a year or two I make a clean-up. You understand of course how that is?"

Both his auditors nodded knowingly.

"Well, what it is you want us to do, give you the money and let you handle it?" inquired Max suspiciously. "Me, I don't know about that, Moe, you see"—

"Not a-tall, not a-tall," hastily interrupted Moe. "You would be fine suckers to hand your money over to any one, let alone a feller you ain't seen for five years who may be a low-lifer and a crook for all you know. No, we work it this way. I tell you when to buy and when to sell. You take your money to any broker you want to deal with and you needn't even tell me his name. You just give me twenty-five per cent. of the profits as you cash in."

"But, Moe," said Meyer. "that ain't fair to you. You should have half anyway."

"No, Meyer, when I do business with old friends like you and Max, I ain't a Shylocker. Twenty-five per cent. should give me a neat profit."

Under instructions from Moe, Max and Meyer margined two hundred shares of Holdfast copper, and true to his prediction, within a week the stock jumped ten points, and he advised them to sell. And with the five hundred dollars in his pocket, the canny Moe told them to go short for a five-point drop, and to call the stock when it reached this figure. The advice was followed, and the profits taken.

During the next three months, Max and Meyer played the stock market game under the direction of the expert Moe, with the usual experience of speculators—having losing days and winning days, but always a rosy hope for the future.

"I tell you, Meyer," said Max to his friend as they were talking over market conditions in the private office of the Emporium, "Allus I did say to you that Moe Bernstein is one smart boy. I don't see how he does it. Of course it ain't allus as he says exactly, but you can't blame the boy for a sudden strike, or a freight embargo or anything like that which sends the market down, or for court decisions and fluctuation in forrin' exchange what sends it up when we expect it the other way. Of course as it stands now we are with the slump yesterday about five hundred dollars to the bad, which is what I call lucky considerin' everthing, and I think Moe will have it all doped out how we can make that killin' before long. Moe is a smart boy, Meyer, he is a boy what any man could be proud to own as a son, Moe is a boy what—"

"Say, what are you fellers conspirin' about," broke in a new voice, and they looked up to see the smiling face of Abe Morgenberg.

"Oh, hello, Abe, come on in," said Max genially. "Meyer and I were just talkin' over the stock market in a general way. What do you think, Abe, is conditions in Europe goin' to get any better? Moe, he says," and then Max stopped, for Moe had exacted a solemn promise that no mention should be made of his connection with the speculating firm of Rosenheim and Goldman.

"So," said Morgenberg, "Moe Bernstein has got you fellers interested in the stock market. Well, Moe is one smart boy, and I don't mind tellin' you that he gives me advice too. Of course he don't allus hit it; like last Tuesday he tells me to sell Holdfast copper because the coal miners' strike is sure to depress the market—"

"Hey, Abe, you make a mistake. I have it down here. On last Tuesday Moe told you to buy Holdfast copper because the supply in France already is exhausted and demand will send the stock up."

"No, Max, I made no mistake. And two weeks ago

and out of the lives of Rosenheim, Goldman and Morgenberg.

"So," said Max, "that was how he worked it. He gets his twenty-five per cent. of the profits, and one of us is sure to win. Here we are, thinkin' one day we are bears and the next day we are bulls, when all the time we are goats."

"Just the same, Max," said Meyer stubbornly, "I say as I said before, that there is a lot of easy money to be made in the stock market."

"Sure," said Max, "I've seen it done."

## Two New Mercer Closed Models

MERCER distributors and dealers have been notified by Hare's Motors, Inc., 16 West 61st, New York, of two new Mercer models, a touring limousine and a four-passenger coupe as permanent models of the Mercer line. They will be mounted on



Mercer Touring Limousine.

Friday he tells me to buy Amalgamated Iron which was another little mistake—"

"Wait, wait," said Max excitedly. "That day it was I remember he tell us to sell Amalgamated Iron short and we clean up a thousand in one day. Abe I think we better compare our buying and selling orders."

The comparison told the whole story. The foxy Moe played a sure thing. When he advised Max and Meyer to buy, he advised Abe to sell short. As he always recommended a stock that fluctuated over a wide range it was sure to go up, or down, anywhere from ten to fifty points.

While they were comparing records a light step sounded in the hall outside, but they were too busy to look up. The dapper Moe appeared for an instant in the doorway, glanced at the absorbed trio, and realized that comparisons are indeed odious, as Shakespeare says. Silently he turned, tiptoed to the entrance and faded out of the store, out of the town,

a standard "22.5" Mercer chassis of 132-inch wheel-base.

Announcement of these closed cars as permanent fixtures on the Mercer line, which has always been practically an open car line, was a pleasant surprise to the Mercer distributing organization in all parts of the world. It is the first announcement of new models since Hare's Motors Inc., took over the control of the production and distribution of the Locomobile and Mercer factories. While closed cars have long been a feature of the Locomobile line at the Mercer plant open models have predominated.

The method of body construction employed on the new Mercer limousine and coupe is that of the best custom body builders. The frame work is of Western ash with all joints mortised, glued and bolted. This frame is covered with the finest grade of aluminum sheets carefully selected and free of blemish. The metal joints are finished with aluminum instead of brass moulding welded with a non-corroding flux. Thus the possibility of electrolytic action, which is produced by using brass moulding, is eliminated. The roofs are of straight grain, bright finish leather over a padded hardwood base. The painting consists of fourteen separate coats. All hardware is of heavily nickel-plated brass. In order to preserve the popular Mercer body lines forward the radiator, fenders, bonnet and dash are the same as on the open models. All movable floor boards are interchangeable.

The touring limousine has two compartments, separated by an adjustable glass partition, which, when lowered, gives an owner the advantages of a sedan. There are two doors to each compartment and the forward compartment is trimmed in hand-buffed leather and the upper part of the rear compartment in cloth with wool carpet and silk roller shades to match. There is ample leg room in both compartments. In the rear are two folding, front facing auxiliary seats. Dome and corner lights are controlled by a button on the right hand door pillar. Vanity cases are of inlaid wood.

The coupe has permanent wide seats for driver and two passengers, with folding auxiliary seat for the fourth person. Behind the driving seat is a closed storage space and there is a larger, water and dust proof space under the rear deck.

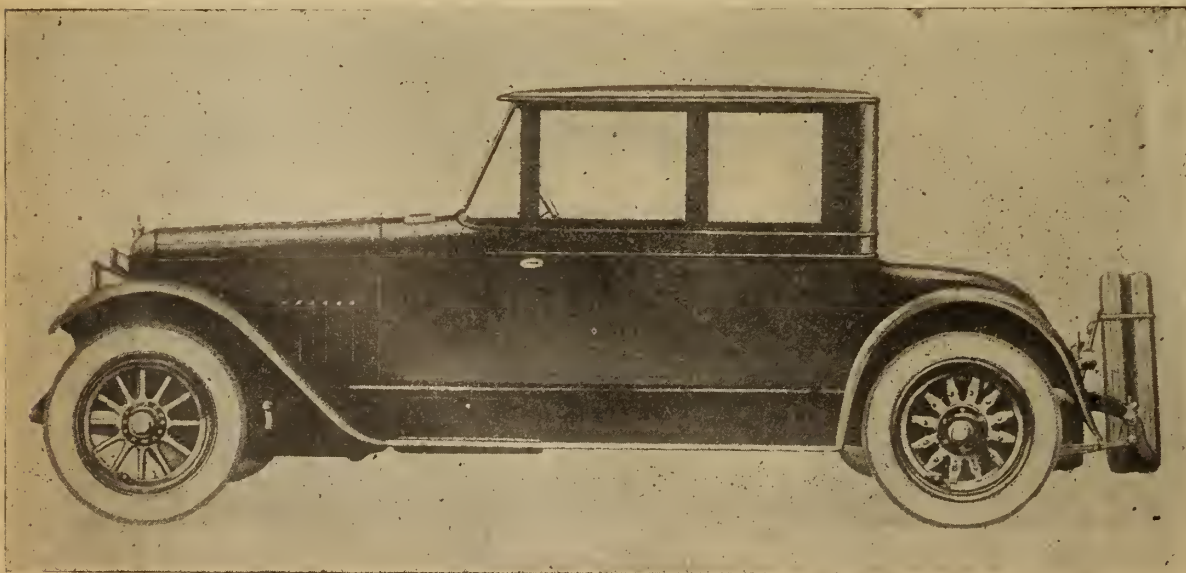

Mercer Coupe.



## Your ambassador to the farmer.

### Let the International Engine represent you and prove the merits of International Machines

**A**PPPOINT a small crowd of dependable **International Kerosene Engines** to go and look after your interests on the farms of a new picked list of your customer-prospects.

Whenever you place one of these little brothers of International tractors, it will come immediately into year-round demand by man and woman. To-day in thousands of farm homes it is considered the greatest handler of drudge-jobs to be found on any market. It is acknowledged the most sensible engine for pumping, washing, separator-turning, churning, grinding, shelling, etc. Made in 1½, 3, 6, and 10 h.p.



Do not underestimate the power of **International Kerosene Engines** for building good will. Trade thrives on satisfaction. Take these engines out on your territory and let them go to work here and there in their dependable, satisfactory manner. They will prove the merits of **International Farm Machines**. Ask the International blockman about the complete and thorough selling assistance we have ready to apply.

## INTERNATIONAL HARVESTER COMPANY OF CANADA LTD. HAMILTON CANADA

WESTERN BRANCHES — BRANDON, WINNIPEG, MAN., CALGARY, EDMONTON, LETHBRIDGE, ALTA., ESTEVAN, N. BATTLEFORD, REGINA, SASKATOON, YORKTON, SASK.  
EASTERN BRANCHES — HAMILTON, LONDON, OTTAWA, ONT., MONTREAL, QUEBEC, QUE., ST. JOHN, N. B.

**I**F you are the International agent—putting **International Hay Presses** out on your territory in the near future will be one of your opportunities. The high hay market makes it especially worth your while to build hay press sales. One of our advertisements is shown here. Let the branch house help you to make the most of the opportunity.

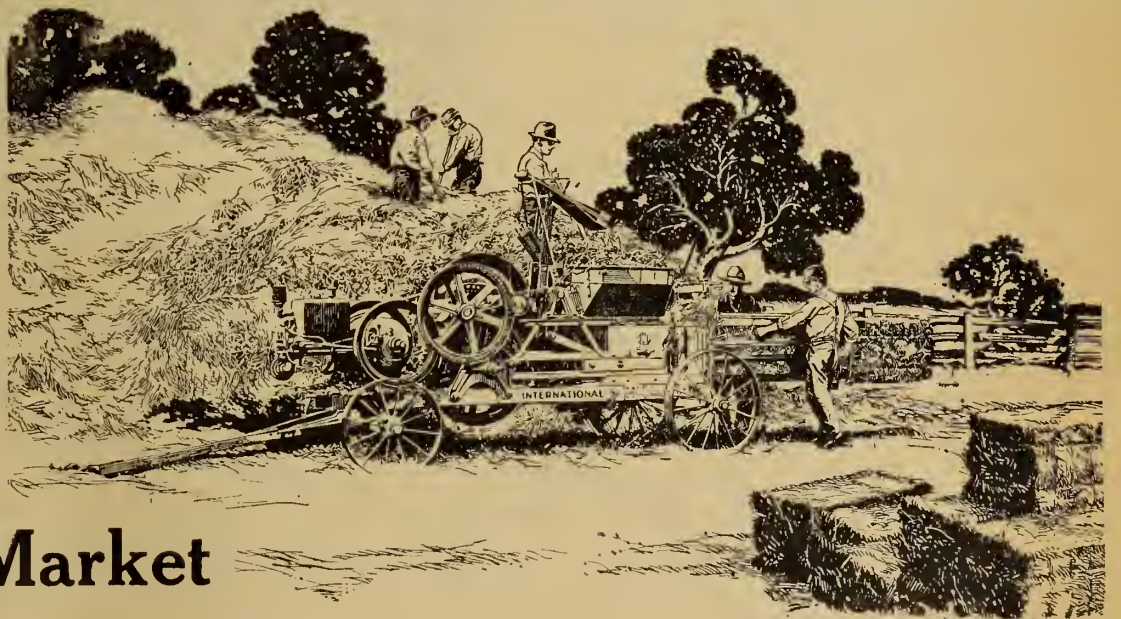

## The High Hay Market

Stacked hay or hay in the mow does not represent hay at its best. Tuck your hay into snug, tight bales with an **International Hay Press** and get all of it under cover. You can ship these snug bales to the outside markets and command top prices. You can bale for your neighbors and make considerable profit. You can bale straw just as well as hay—keep the outfit busy during odd weeks between seasons.

Your light tractor will furnish ample power to operate an International Power Press. If you do not have separate power, a 6 h.p. International Kerosene Engine can be mounted on the front end of the frame of the two smaller size presses and belted direct to

the baler—always ready for immediate service. The extra large drive gears compound the engine's power enormously—make snug, tight bales of uniform weight.

**International Hay Presses** are made in three sizes—14 x 18, 16 x 18, and 17 x 22—horse and power styles. See your International agent about one—and meanwhile ask us to mail you a catalog.

## INTERNATIONAL HARVESTER COMPANY OF CANADA LTD. HAMILTON CANADA

WESTERN BRANCHES — BRANDON, WINNIPEG, MAN., CALGARY, EDMONTON, LETHBRIDGE, ALTA., ESTEVAN, N. BATTLEFORD, REGINA, SASKATOON, YORKTON, SASK.  
EASTERN BRANCHES — HAMILTON, LONDON, OTTAWA, ONT., MONTREAL, QUEBEC, QUE., ST. JOHN, N. B.



# The Future of the Automobile Industry

"The Wise Merchandisers are Preparing for the Time when They will Have to Sell in the Wake of Keen Competition," says S. M. How, General Sales Manager of the Haynes Automobile Co.

"THE time is not very far distant when automobiles priced at two thousand dollars and over will have to be sold through intensive selling methods, because of the keen competition, which is certain to accrue," says S. M. How, General Sales Manager of The Haynes Automobile Company. "For the past year there has been a great and unusual demand for automobiles of all descriptions. The insatiable cry for dependable cars still exists, but the big problem with most all of the automobile factories is solely one of production. Almost every factory can boast of a roster of a thousand or more unfilled orders.

"This state of affairs has brought about something more than the fact that automobiles are needed and wanted by people the world over. It has led executives to higher ambitions. It has imbued the men who control the outputs of large automobile factories with the desire to fill as big a part of this demand with their product as they possibly can. You can pick up almost any automobile trade paper and read about some mammoth factory or factory addition being started or contemplated. The daily newspapers contain similar items. There are also many write-ups announcing new automobile productions. All these things must surely indicate future trade monopolies and keen competition ahead.

"This year there is plenty of room for all. In fact there is a demand for a great many more cars than will be manufactured. It seems that everybody wants an automobile. Today it is not a question of selling, but one of filling the demand. How long is this favorable situation going to last? Certainly there will come a time when the gap between supply and demand will not be so pronounced. When this time comes it will call upon every bit of resourcefulness that automobile merchandisers possess to influence the car-buying classes to choose their particular cars. Intensive selling methods will consequently have to be called into operation.

"EVENTUALLY the automobile business will go through what is called the process of elimination. A new era will be reached. It will be the survival of the fittest. In this era there will, of course, be found hundreds of thousands of automobile buyers, but they will show their preference and choose from a limited number of kinds of automobiles. There will be no room for the car that was hastily designed without regard for the user's interest. Only the well-known cars that have stood the test of time will be considered by the astute purchaser. Countless cars will be engulfed in this vortex of discrimination. Countless cars will be eliminated. The future success of automobiles will depend entirely on the amount of prestige they will accumulate from day to day through consistent performance in the hands of owners.

"To easily imagine what the future of the automobile industry will be, one need only recall to mind the process of elimination experienced by the bicycle, the typewriter, and the cash register business. One can quickly count the remaining institutions that control the present outputs of these daily necessities. The public, however, is responsible for this situation, and rightly so, because the public invariably demands the quality product. These monopolies exist today because those large institutions have demonstrated to the buying public that they are better equipped and qualified to produce those requirements. The many other concerns which had equal opportunities at the start failed to compete because they did not build for permanence, nor did they prepare for that inevitable time when supply meets demand and the process of elimination follows.

"Now what about the automobile industry? What about its merchandisers? The automobile industry is a great business. Every one realizes that. The automobile industry ranks third in the list of America's industries. It is experiencing an unusually successful period of prosperity. During this

interval automobile dealers, and manufacturers as well are prone to forget that an intensive selling period is ahead. Many have slackened their pace. Business today is waiting for them. They do not have to go after it. But this situation won't last forever. It can't.

"The wise merchandisers are preparing for the time when they will have to sell in the wake of keen competition. Keen competition brings with it its expensive methods. Numerous automobile dealers and manufacturers will not be ready to meet the expense and force of unrelenting competition. They will be forced to drop out of the race unless they have planned far enough ahead to cope successfully with the gruelling task of selling in highly competitive times.

"It is not the intention to give a negative impression about the future of the automobile business, but it is desirable for all concerned to realize that the



Is this the oldest Ford? The distinction of having the oldest "fivver" belonged to W. D. Walsh, of St. Louis, with a Model B, made in 1903, until the Price Auto Service Co. recently unearthed a Ford Model A at Putnam, Kansas, built in 1902. With the exception of tires and rims the car is just as it was turned out, and it still runs.

time is not so very far distant when it will be necessary to sell cars in the same decisive manner that one typewriter today is sold in preference to another.

"The whole matter of future business resolves down to the necessity of a good product plus intensive selling methods to sell the public on that product. If automobiles always occupy the same relative and important position in our daily lives as they do today, and there is every reason to believe that they will, there will always be that great demand for them.

"The future is bright, but the car-buying public more than before will demand the best that engineering brains can give them. Therefore, those automobile manufacturers who are concentrating on serving the public in the most efficient and thorough manner, and those dealers who are laying their plans for the highly competitive period which is bound to come sometime in the not distant future, will remain leaders in their communities as they questionably are at this time."

## I. H. C. Engine and Tractor Book

DUE to increasing demands which are coming from all parts of the world, the International Harvester Co. has published another edition of Internal Combustion Engines and Tractors, a 175-page book dealing with problems of development, design, construction, function and maintenance of engines and tractors, which is compiled from a series of

lectures delivered by Oliver B. Zimmerman of the company's engineering staff.

The well illustrated text is logically arranged, starting with a brief discussion of the development of the internal combustion engine, then taking up the problems of design with a classification of engine parts on the basis of the functions which they perform. Next the question of fuels and lubrication is discussed. Following this there is a consideration of tractor requirements, plowing speeds, materials used in engines and tractors and processes in handling materials.

Four chapters are devoted to various phases of tractor operation. One of these gives a very complete list of tractor troubles, with methods of diagnosing and remedies. The final chapter is devoted to a discussion of plow adjustments, care and operation. Dealers and users can get much valuable information from this work. The manner of treatment is simple and the use of technical terms has been reduced to a minimum.

## Quebec Tractor Demonstration

THE annual plowing match and tractor demonstration under the auspices of the Eastern Ontario and Western Quebec Plowmen's Association will be held at Macdonald College Farm, St. Anne de Bellevue, Quebec, on Oct. 12, 13, 14, of this year.

The demonstration has been somewhat reorganized this year. In connection with the tractors substantial prizes are being offered in a class for bona-fide farmers, the quality of the work alone to be considered, as in horse plowing. This is being done by the promoters to stimulate greater interest on the part of the farmers in tractors and tractor operation.

Then there is a class for manufacturing companies—ploughing competition in sod. In this class the machines will be rated on speed, quality of work, and fuel efficiency.

In addition to these two classes arrangements have been made for public and private demonstrations. The program will be handled as follows:

Setting up day and trying out machinery Oct. 12. Oct. 13th at 9 a.m. manufacturing companies' tractor plowing competition. In this class each tractor will only be given the amount of land it can finish by noon. There will be no demonstrating while this competition is on.

From 1 p.m. until 3.30 or 4 p.m. the public demonstration in plowing, disking and cultivating will be held. After this event each company will be allotted a piece of ground to public demonstrations and at 4 p.m. private demonstrations for the benefit of their prospective customers.

On Oct. 14th, at 9 a.m., the bona-fide farmers tractor plowing competition will take place. At 1 p.m. public demonstration and at 4 p.m. private demonstrations as on the 13th.

The association has secured the services of Prof. W. H. Day, of Guelph, as Field Manager and Dr. C. J. Lynde, of Macdonald College, as Inspection Manager. These men are well qualified to handle the events in an orderly and impartial manner and the association is looking forward to the co-operation of the various companies to make this the best educational event of the year.

The arrangements are in the capable hands of L. C. McQuat, of Macdonald College, secretary of the association.

Professor C. F. Mabery, of the Case School of Applied Science, Cleveland, Ohio, in an address before the Engineers' Club predicted that within two years gasoline will be retailing at from fifty to seventy-five cents a gallon in all parts of the United States.



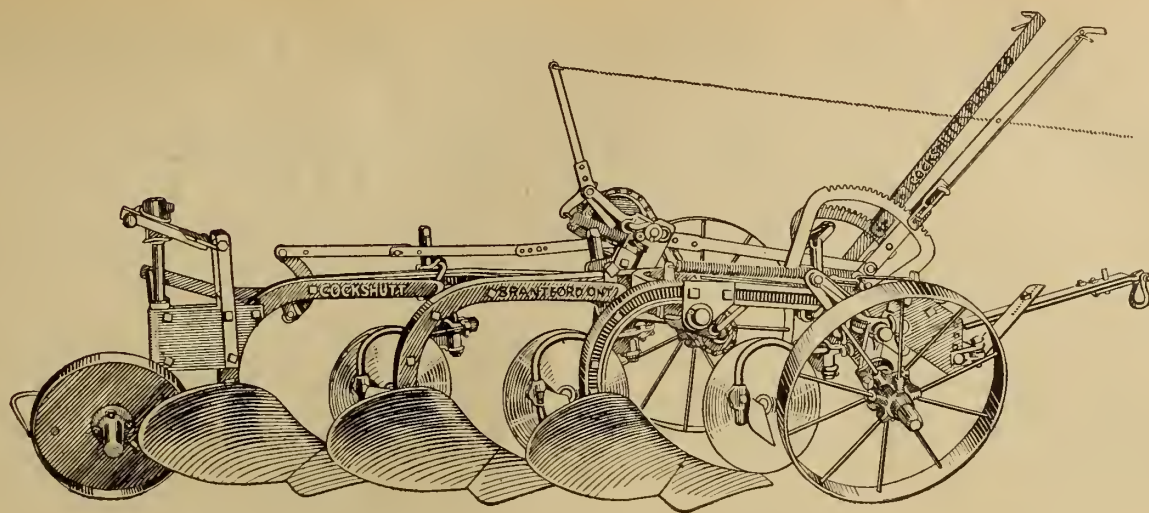

# Cockshutt Tractor Plow

The easiest sold Plow in Canada to-day. Its reputation for splendid plowing in any soil and with any make of Tractor makes it one of the best "self-sellers" you ever handled.

An implement specially designed by experts for tractor plowing. Has heavy beams, heavy braces and substantial construction all through —yet it's surprisingly light in draft. This is due largely to the correct design of the bottoms — they turn clean-cut furrows. Two

easily reached and readily operated levers set the plow for its work. Can be hitched to any make of Tractor. Adjustments up and down as well as sideways are provided. A plow that "stays sold" and makes firm friends for you with your customers.

Built in 2 and 3 furrow sizes with 10", 12" or 14" bottoms. We have larger sizes in independent beam plows, and a big line of Tractor Disc Plows and other Tractor implements. Let us send you full particulars.

**Cockshutt Plow Co.**  
LIMITED

Brantford      Winnipeg  
Regina      Calgary      Saskatoon

*Sold in Eastern Ontario  
and Eastern Canada  
by*

**The Frost & Wood Co.**  
LIMITED

SMITHS FALLS, ONT.  
Montreal      St. John

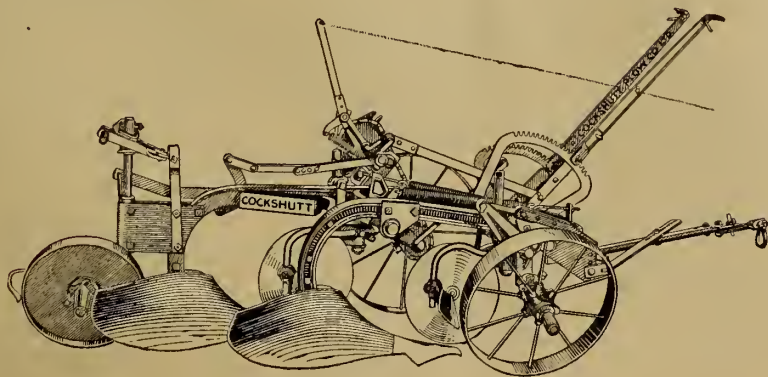

This is one of the most popular of a complete line of Cockshutt and Frost & Wood implements. Backed by big advertising and Dealer Service that never lets up.



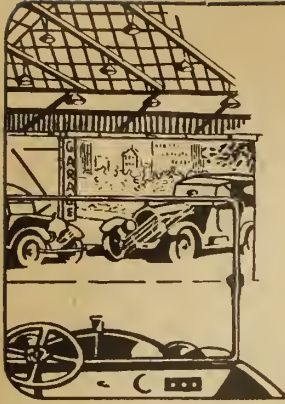

# SHOP NOTES FOR THE GARAGE MAN

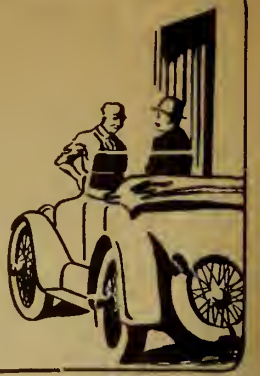

## Special Appliances for Expediting Automobile Process

By VICTOR W. PAGE, M.S.A.E., in Everyday Engineering

THE production of enormous quantities of popular priced automobiles has created a new industry and that is the production of special tools, jigs and fixtures for making repair work easier on such makes of cars as are sold in quantities. In the early days the repairman was forced to make his own special fixtures because none were obtainable on the market and it was not often a profitable thing to do because it was seldom automobiles of one make would be received for repairs to warrant the expenditure of money and labor. Now conditions are changed and so many cars of certain popular makes such as the Ford and the Overland are used in even small communities that almost any service station is justified in stocking certain fixtures.

Even the smallest shop should include valve head and valve seat ream-

ers. It is provided with two large trays, 22 inches by 24 inches for convenience, where the workman can place his tools, motor and axle parts. The stand is mounted on three 4-inch diameter wheels. The rear castor wheel is so constructed that by pulling the plunger lock the castor will swing up off of the floor and the stand will then rest firmly on its legs. By kicking the castor lever down the stand will go back on its wheels and lock automatically.

The work bench is also equipped with a machinist's vise, which has a 3-inch jaw with a 4-inch opening which will handle any work required in overhauling a Ford motor or axle, also other kinds of work that will suggest itself to the repairman. The work bench and engine stand is 36 inches high and takes 27x42 inches floor space, it weighs but 120 pounds and can be moved from one part of the shop to the other or used on the road as part of the equipment of an emergency repair car.

### Useful Spanner Wrenches

There are various points in an automobile or gasoline engine that cannot be reached handily with the usual form of adjustable spanner wrenches. One of these points is the packing nut on the water pump which is generally hard to reach and which is so large as to require a special wrench. The simple wrench shown at A in the accompanying illustration may be made by any one handy with tools by cutting a piece of 1/8-inch thick sheet steel to the desired shape, then carefully fitting the jaws so that they will be the exact size of the nut on the stuffing box, by filing. After the wrench is completed the jaws should be case hardened. The handle is made by riveting two pieces of fiber to the bent portion or off-set of the wrench.

When a number of nuts are to be removed from a point where the bolt heads must be held from turning, as those holding the lower portion of the engine crank case to the upper part of it or keeping a differential housing together the speed wrench shown at D is a very useful fitting that can be made by any repairman and will save its small cost on a single job. It will

readily assemble, or disassemble, any flanged parts held together by a series of bolts because it holds the head of the bolt from turning while the nut is unscrewed or replaced. A socket wrench is brazed or welded to the shank of a cheap bit stock or a simple bar of steel may be bent to perform the same functions, and a handle placed on the end as a hand grip. The wrench that holds the bolt head from turning is welded to the end of a forged bar shaped something like a hack saw frame and having a bearing at the end opposite the head of the wrench to receive the extension from the bit stock. A spring is used between the head of the movable socket wrench and the bearing on the forged bar carrying the fixed socket wrench.

This may be made as strong as desired and is intended to hold the wrench firmly in place on the nut. A stop-pin may be placed in the bit stock if desired to keep the movable wrench from backing out too far. When it is desired to move the wrench from one bolt to another the spring is compressed by pulling back on the bit stock and the wrench may be readily withdrawn and moved to a new bolt. If the movable socket is made long enough it will hold several nuts, forming a magazine that need not be emptied each time a nut is removed from its bolt. The general construction is clearly shown and the design can be duplicated by one possessing even a modicum of mechanical skill.

To fabricate a socket wrench is not difficult as the simple socket wrenches to fit square or hexagon nuts may be readily made as shown in the accompanying illustration. With that method it is necessary to secure a piece of seamless pipe or tubing of a size just large enough to go over the nut. For example, if a 3-4-inch square nut is to be removed, the wrench must be made from tubing having at least 3-4-inch inside diameter. The end of the tube, when heated to a red heat is placed over the nut and then hammered down on each facet, so that the tube end is hammered down and shaped to fit the nut at the same time. If a deeper wrench is desired, a piece of hexagon or square rod of the proper size may be used as a mandrel to form the required length of socket. Seamless steel tubing is the best material to use and after the wrench is made it may be well to case harden the formed end. The tube is cut to any desired length, six inches being the average for ordinary work and a 1-4 inch or 5-16 inch hole is drilled 1-2 inch from the top

end of the pipe through which a short piece of iron or steel rod of the proper size may be inserted as a handle.

In the case of a hexagon wrench three holes are usually drilled through the end to correspond with the facets of the nut, one being placed below the other in the handle end of the tube.

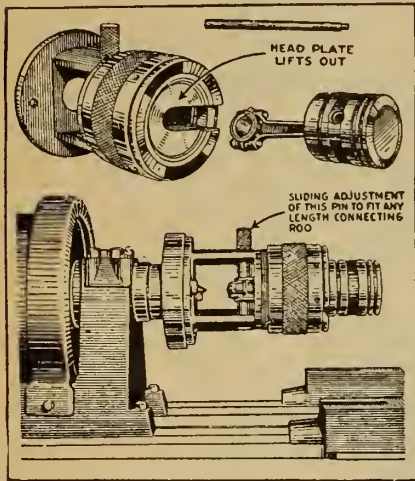

Special Lathe Chuck for turning piston ring grooves.

ers, valve grinding tools, bushing extractors, gear pullers and other devices of that kind. Shops of greater pretensions can now obtain engine supporting stands, special cylinder boring tools, reabbiting jigs, piston chucks and vices, connecting rods, aligning and reabbiting fixtures and numerous others that reduce labor and repair costs and yet that can be procured at much lower cost than they could make the devices in their own shops because they are the product of manufacturers specializing on such tools and appliances.

The Ekern motor stand is one of the handiest devices of its kind for use in shops and garages doing Ford car work. The Ford motor, when taken from a car, can be fastened to the stand by the two cap screws which screw into the side of the motor where the water inlet connection is fastened. The stand is so constructed that the part screwed to the motor will revolve in the clamp on the stand and can be locked by tightening the lock-screw, which will hold the motor in any position or angle desired to suit the work-

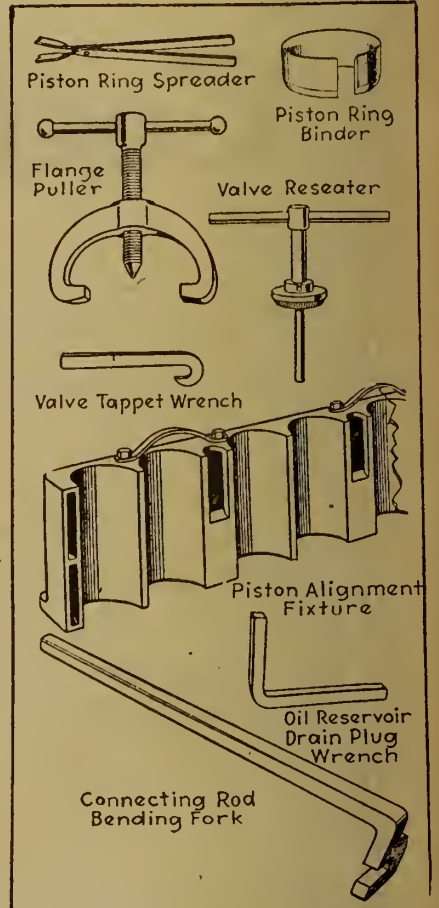

Special tools for Hudson cars may be modified for work on other makes.

For a square wrench, it is only necessary to drill two holes, these being at right angles to each other as indicated.

### How Automobile Factories Help

It is remarkable how the various automobile factories now co-operate with the repair-man in giving service to the owners of their cars. Some of the special tools furnished by the Hudson Motor Car Co. and described in a special pamphlet are intended primarily for work on the Super-Six but there is no reason why modifications of these tools should not prove valuable to repairers of other makes of cars. These tools are shown in accompanying illustrations and a brief recapitulation of their use follows:

#### Piston Ring Spreader

This is a convenient tool used to install or take out piston rings and its use will prevent chance of breaking the ring or burring the edges. It may be used on any car.

#### Piston Ring Binder

This device is used for compressing rings into the cylinder. It is placed about the piston and rings and the pis-

Continued on page 30

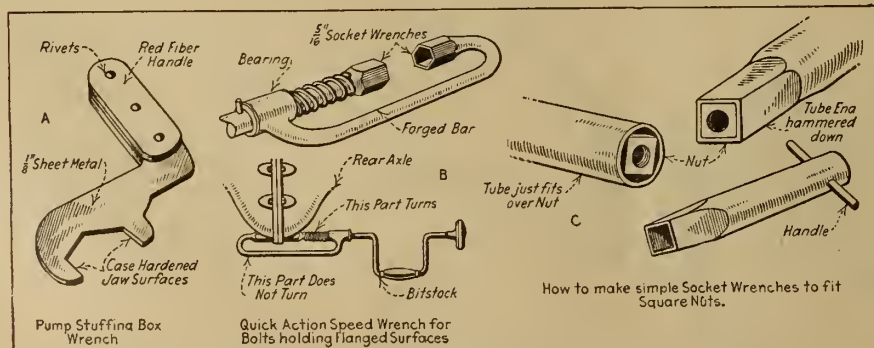

Special wrenches that are easily made by the repairman make it possible to remove stubborn nuts and bolts easily.



# The Garage Owner who prides himself on service will install a Universal Cylinder Reboring Tool

The annoying delays that follow the sending of automobile, truck, tractor or gas engine cylinders to the factory for reboring can be eliminated.

Your customers can get as good a job—a bore as smooth and round as when it left the factory—right in your garage.

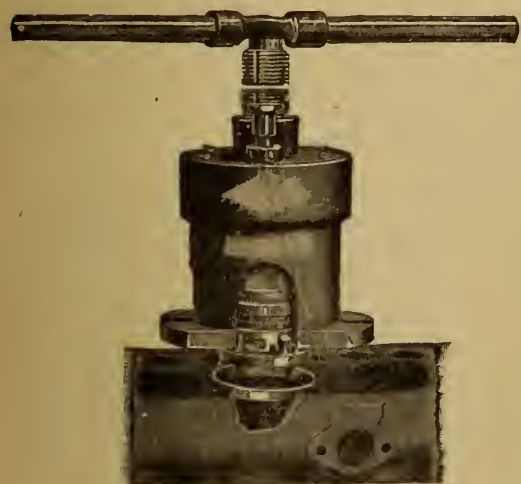

Operating on a detachable head motor—by hand

You can give prompt, efficient, satisfactory service, and earn considerably greater profits—You can if you have a Universal Cylinder Reboring Tool.

This tool is used and recommended by nearly every manufacturer of pleasure cars and trucks, including Ford, Dodge, Studebaker, Buick, Page-Detroit, Chalmers, and many others.

In every garage where it is used it has proven a highly profitable investment and has met every requirement as to accuracy, workmanship and general excellence.

It may be operated in conjunction with a power-driven drill press with the cylinder on the table, as well as by hand.



**Tool complete ready for shipment**

Clip this coupon and mail it to us. Get fully posted on the merits of this service-giver and profit-bringer.

## Windsor Machine and Tool Works

86-88 Pitt Street, Windsor, Ontario

I, (or we) am interested in the UNIVERSAL CYLINDER REBORING TOOL, and would like to get more information on this equipment. You claim it will materially increase profits of this business; if so, I (or we) am anxious to know about it.

Send any literature pertaining to same to

Name ..... City .....

Street ..... Prov.....

We repair the following cars .....

Name of my jobber .....

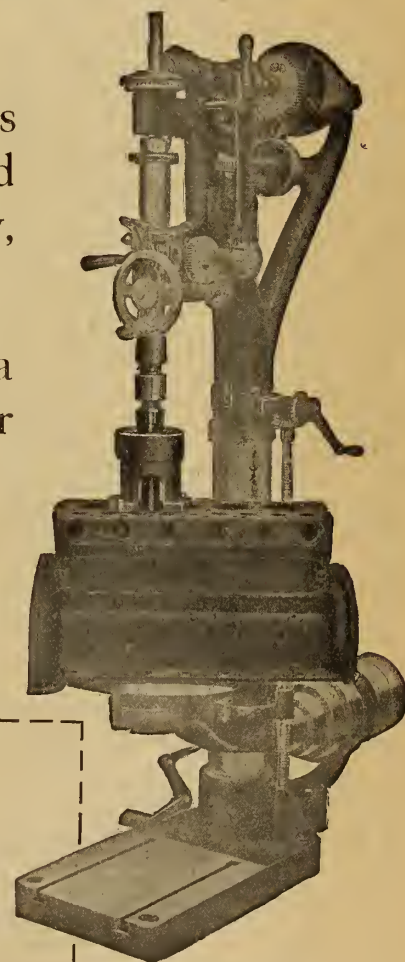

**Operating with power-driven drill press**



# Automotive Accessories and Implement Equipment

## FORD POSITIVE OILER AND GAGE

THIS is a positive oiler and sight dash gage for the Ford car. It insures the Ford driver that he has a supply of oil, for as soon as the oil is low or the danger point is reached the gage becomes inoperative. The danger of running the car for miles with low oil is eliminated. This gage also supplies an additional quantity of oil to that furnished by the internal pipe in the Ford engine. An oil strainer is provided which continually strains the oil as it is circulated. The installation of this device is very simple. It is only necessary to remove the old transmission cover and replace it with the new one. The pipe leading to the gage is threaded underneath the floor board to the gage which is placed on the dash. The second lead from the gage runs directly to the oil filler of the engine, for which a special plug is provided in which is placed a fine mesh screen. This device is made by the Automotive Material Co., 208 N. Wabash Ave., Chicago.

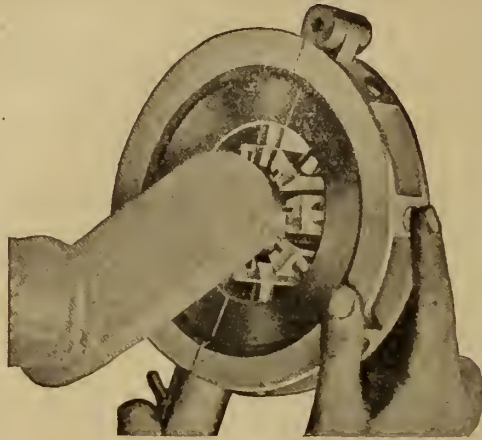

Peters' Crankshaft Grinder

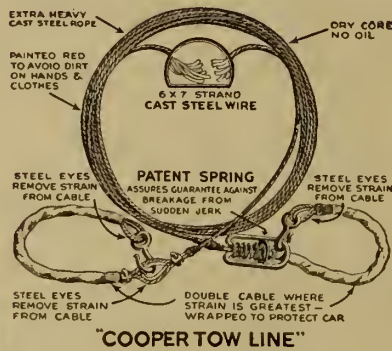

"COOPER TOW LINE"

## FULL RAY HEADLIGHT DEFLECTOR

THE motorist who drives at night is faced with the problem of getting sufficient illumination of the road ahead of him and still complying with the anti-glare law. The non-transparent deflector shown in the illustration will, the makers claim, eliminate all harmful glare without interfering with the intensity of the illumination where it is needed for driving and where the law demands it. It is an arrangement of non-transparent metal slats which permit the reflected light to be thrown on the road in front of the car. The rest of the light is thrown ahead and kept below the 42-inch line required by the law. It is manufactured by the Bradsto Appliances, Inc., 65 Main Street, Buffalo, N.Y.



Full-ray Headlight Deflector.

## H. B. BATTERY CHARGER

THIS outfit is known as the H. B. 500 Watt Battery Charger and has ample capacity to charge one to eight six volt batteries with a special automatic voltage control that enables the operator, the makers say, to recharge six, twelve or twenty-four volt batteries at the same time. The charger is self-starting, using city power, either alternating or high voltage direct current. It is easy to install and operate, as it is self contained and mounted on one base complete with switch panel and the necessary instruments.

The battery charger is 26 inches high, 27 inches long and weighs 280 pounds. Its capacity is 10 amperes, 60 to 70 volts, varied by the number of batteries on charge. The switch board is made of clear black electrical slate, equipped with ammeter, field rheostat, voltage lamps and two controlling switches. The outfit is manufactured by the Hobart Brothers Company, Troy, Ohio, and distributed in Canada by the Battery Service and Sales Co., of Hamilton, Ontario.



Hobart Bros. Battery Charger.



Positive Oiler and Gage.

## E. B. COMBINATION MANIFOLD

THE E. B. Combination Manifold for tractors is manufactured by the Emerson-Brantingham Company, of Rockford, Illinois. High fuel economy and practically complete burning of kerosene, say the makers, is secured by the Stromberg kerosene carburetor and the E. B. Combination Manifold as shown in the diagram, the intake is inside the exhaust manifold where the lower side is in contact with the hot burnt gases. When the part of the fuel that did not gasify readily at the carburetor reaches the heated intake, the heavier particles settle to the bottom or heated part, where the heat breaks them up into a gas. By having the upper side of the intake cool, the intruding charges are prevented from reaching such a temperature that the explosive power is lessened.

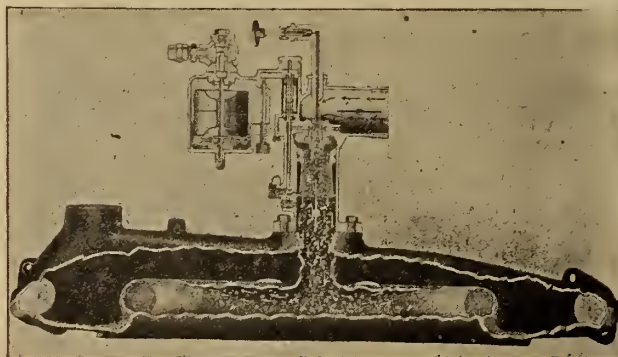

E. B. Tractor Combination Manifold.

## COOPER TOW LINE

THE Cooper Tow Line has an ingenious patented spring which the makers claim takes up the jerk, prevents breakage, and eliminates the bending of axles and loosening of springs. When a jerk occurs the spring acts immediately and compresses with the strain until the yoke rests on the shoulder. The loops for attaching to the car are wrapped to prevent scratching and marring running gear.

The cable is made of heavy cast steel wire, 6x7 strand dry core. It is made by the Cooper Manufacturing Co., Marshalltown, Iowa.

## PETERS' CRANKSHAFT GRINDER

THIS tool, made by the Aluminum Brazing Solder Co., Philadelphia, Pa., is designed for truing up eccentric crankshaft pins. The difficulty of truing up a crankshaft lies in centering the crankshaft pins, which are eccentric to the main bearing pins. The shape of a crankshaft is such that spring action is unavoidable, say up to a quarter of a thousandth of an inch.

It consists of a chuck-like housing, made of aluminum, an inch and one-quarter wide, to go between any size bearing now used in the motors of autos or motor boats. The housing is split and hinged to allow the tool to go around the pin, thereby eliminating any centering.

The tool has eight high-speed steel cutters, which work toward the centre and which are operated by means of a screw-plate, which moves all of the cutters to and from the centre universally.

To operate, open the tool and place it around the pin, turn the screw-plate with the spanner wrench until the cutters start to cut. A few complete turns of the tool will remove the high spots, leaving a perfectly round, smooth surface. The entire operation takes but one-fifth the time ordinarily required on a lathe.

This tool can be adjusted to one-five thousandths of an inch. It requires no service for re-sharpening, as the equipment includes a re-grinding device, which enables the user to keep the knives in perfect cutting condition at all times. The makers guarantee it for one year against all physical defects.





## Nothing Succeeds Like Success

**I**T is significant that the more Goliath Spark Plugs we sell, the more repeat orders we receive. The demand is phenomenal.

A spark plug is more than mere metal and insulation—it is the all-important transmitter of electrical energy which determines power, pick-up and that smooth purr of the engine in which all motorists take so much pride.

Every spark plug you sell influences the minds of your customers, favorably or otherwise, towards your business. Experimenting is costly. Goliath Plugs have been "Tested for Service."

**LIST PRICE 75c EACH**

*Our Nearest Sales Branch Can Supply You*

# Canadian General Electric Co., Limited

Head Office

TORONTO

Branch Offices: Montreal, Quebec, Sherbrooke, Halifax, Sydney, St. John, Ottawa, Hamilton, London, Windsor, Cobalt, South Porcupine, Winnipeg, Calgary, Edmonton, Nelson, Vancouver and Victoria.



## Nelson Adds a New Jumbo Truck Model

THE latest model added by the Nelson Motor Truck Co., of Saginaw, Mich., to their Jumbo line is the "Highway Express," Model 20, which is built to meet the demand for a truck of 4,000 pounds pay-load capacity capable of standing up at high road speed.

This truck is the first of its carrying capacity to be built for fast freight transportation. The manufacturers say it is of unusually strong construction to sustain the strains of high speed operation and provision has been made

its own wear automatically and is non-adjustable.

Brake tumbling shafts are provided with brake equalizers in addition to adjusting turnbuckles. Arvac new type universals are used. The propeller shaft of Arvac make is divided, with large SKF bearing in centre support. The front axle is "Stan-par" with back bearings. Springs are chrome vanadium steel, and each leaf is cupped at the centre, to prevent spring slippage.

The radiator is tubular with square

of European manufacturing, sales, and experimental work.

It had been known that Mr. Couchman was suffering from what appeared to be a slight affection of the throat and that he had intended to undergo surgical treatment for it. According to the cablegram death came suddenly while he was in the hands of the surgeons.

Mr. Couchman was born February 27, 1865, at Minneapolis, Minnesota, and entered the employ of the McCormick Harvesting Machine Company's branch house there in 1882. He was then a high-school student and worked after school hours as office and errand boy. From the beginning he showed such aptitude and zeal, and so strong a personality, that opportunity and promotion swiftly followed. In a short time he had progressed through the repairs and bookkeeping departments of the branch house and had also proved his mettle as a salesman on the road. At the age of 21 he was appointed general agent of the McCormick Company, at Marshalltown, Iowa. In the twelve years during which he held this position he exhibited so broad and clear a comprehension of the whole farm implement field that when the McCormick Company sought a man in its American establishment fitted for still higher service abroad the choice unhesitatingly fell upon him. In 1899 he was given charge of the McCormick Company's European headquarters at Hamburg. He remained there until the Harvester Company was formed in 1902, when he was assigned to take charge of the company's interests in what are known as the Central and Eastern European Districts.

Upon the removal of the Harvester headquarter's office in 1912, Mr. Couchman was given the responsibility of all European sales, and during the next four years his rare faculty for organization and his ability in developing business were of the utmost value in perfecting the Harvester System of distributing its products in Europe.

In 1916 he was recalled to the United States, being appointed division manager in charge of all sales, foreign and domestic. During the war years that followed he rendered to the company service of the utmost value.

Early in 1919, as soon after the end of the war as the transfer could be arranged, Mr. Couchman was sent abroad once more, this time with the rank and title of vice-president and with authority to direct all the Company's manufacturing, sales, and experimental work in Europe. In the face of all the difficulties accompanying rehabilitation on the Continent he had already gone far toward building the European organization anew, re-establishing connections that had long been broken or abandoned, and resorting to the company's business.

Mr. Couchman is survived by his widow, formerly of Marshalltown, Iowa, and by two sons, William V., Jr., and Carl, both of whom are connected with the Harvester Company's Company organization.

## SHERBROOKE FAIR

FROM an implement point of view the Sherbrooke Exhibition, Quebec, was a very poor one. For five years the implement manufacturers have refused to exhibit, giving as their reason that they are oversold and that such exhibiting would be needless expense.

There was one tractor there, the Cleveland Tractor, and that one unfortunately was not even given the prominence it should have received. It was not until Friday that the management and the Cleveland Tractor people were able to get together and arrange the demonstration before the Grand Stand. It is hoped in future that the management of the Sherbrooke Exhibition will arrange for some such demonstration during the days of the fair and not at the close when very few are there to witness it.

The tractor is not as popular in the Eastern Townships as it should be, the farmers claiming that the country is hilly, with numerous brooks and rivers and is not adaptable to the tractor. However, the caterpillar tractor has been used successfully in this locality, and the farmers will in time be educated in using the tractor and will realize its economic value.

A. Belanger Manufacturing Company had a fine exhibit of their harrow and plow and it was through their aggressiveness in conjunction with the Cleveland Tractor people that the tractor demonstration was made on Friday.

There was always an interested crowd around the exhibit of the Renfrew Machinery Company demonstrating their new engine run on compression, no carburetor, no batteries, no spark plug, no magneto.

The Power Milking Machine was the only farm implement that was well represented. The De Laval Milking Machines, the Sharples milking machine, Empire milking machines, Macartney Milking Machine Co. all had representatives and a great deal of interest was shown in these machines. De Laval and Simplex separators were also well exhibited.

Dr. Tolmie in his speech referred to the use of modern machinery as a great saving of labor and time, and urged the adoption of the co-operative system by which implements could be purchased at a low individual cost.

The management of the exhibition interviewed the Dominion Minister and asked him to use his influence in having the implement manufacturers exhibit at fairs.

The farmers in the Eastern Townships are slowly awakening to the economy of power farming. In a few years it is expected that power farming will be adopted on a large scale in the Eastern Townships—one of the best if not the best dairy farming districts in Canada.

SASKATCHEWAN has a population of 750,000 and about 60,999 automobiles. This is one to every twelve persons.



The new Jumbo Highway Express, Model No. 20.

to cushion and absorb resultant vibrations so that undue wear is avoided. By reason of its road speed ability on pneumatic tires it is well adapted for long distance hauling where time is an important element and speed is essential, such as the produce of dairymen, general farmers, market gardeners and fruit growers, etc.

The standard body size is 5 ft., 4 in., x 10 ft., 6 in. The space back of the cab to the rear end of the frame is 120 inches. The new model is also admirably suited for passenger work. A 24 to 26 passenger bus body can be used without exceeding the rated carrying capacity. The comfort of the driver has been given serious consideration. The cab is of steel and there is plenty of leg and seat room for three big men. The doors swing back and may be locked securely against side of cab. The side and back curtains are fitted on steel frames and disappear into the sash panels when not in use. The door curtains are fastened to steel rods and open with the doors.

The motor is a Buda C.T.U. Model, 3 3/4 in. bore x 5 1/4 in. stroke, with an A.S.E. horse-power rating of 22.5, removable cylinder head, and full force feed lubrication. The oil-pump is gear driven off the cam shaft. Centrifugal pump distributes water first around the valves before reaching the cylinder walls. A hot spot manifold is used. The motor rocks in a large pilot bearing in specially designed "I" beam motor support which is easily removed with the motor, when lifting same out of chassis. Alemite lubricating system is used throughout. A fan shroud forms a perfect air tunnel, enabling uniform passage of air through entire surface of radiator core.

Clark internal gear axle is used. The gear reduction is 7.2 to 1. Road clearance on pneumatic tires is 14 inches. The brake drums are 16 in. in diameter. The bearings are Hyatt. Fuller transmission with nickel steel gears, chrome nickel steel shafts, hardened and ground. Raybestos multiple dry disc clutch is used. The discs are of saw steel type, heat treated, hardened and tempered. The clutch takes up

pins. The tubes are easily removable for replacement when same is necessary, by lifting off the top section.

The Model 20 and Model 15 have the same chassis and the same equipment—Model 15 on solid tires and model 20 on pneumatic tires. Model 20 on pneumatic tires is given a rated payload carrying capacity of 4,000 pounds. The body allowance is 1,000 pounds, and weight of chassis 3,750 pounds.

Model 15 on solid tires is given a rated payload carrying capacity of 3,000 pounds. The body allowance is 1,000 pounds, and weight of chassis, 3,600 pounds. The sole distributors for these trucks in Canada are the Motor Car Distributors, Ltd., 27 McGill College Avenue, Montreal.

### I.H.C. EUROPEAN VICE-PRESIDENT DEAD

A CABLEGRAM from Brussels, Belgium, on Wednesday, August 4, brought to the general offices of the International Harvester Company, at Chicago the distressing news that one of its highest officers had passed away—William V. Couchman, vice-president in charge

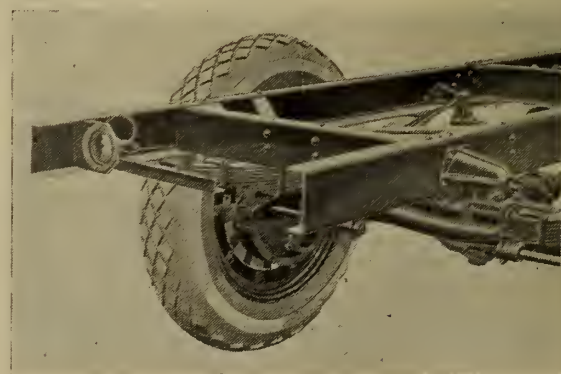

On the left—The new Jumbo removable core radiator with specially designed pins radiating heat away quickly. Due to a straight line design from filler cap to bottom of radiator. The overflow pipe can't be clogged.

The cut directly above shows the rear end of the new Jumbo fitted with electric tail light set flush with frame to prevent lamp breakage. Also shows diagonal braces and presser steel cross members.



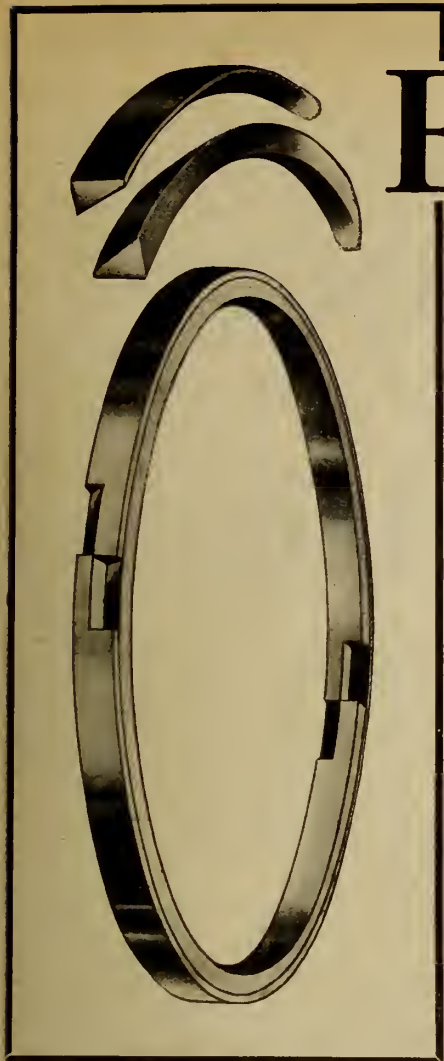

# EXCELLENCE

TWO-PIECE  
PISTON RINGS

## Making every ounce of Gasoline do its work

The instant of explosion, when the gas is hurled with full force against the piston head, is the moment that proves the absolute tightness of Excellence Rings. Fitting snugly, expanding and contracting as necessary, they form a perfect seal for the firing chamber. Every ounce of gasoline exerts its full force on the piston head, every nickel spent on fuel is returned full value in power.

No gasoline can shirk its duty to provide power in a cylinder sealed with Excellence Rings. Excellence Rings are now being supplied in the following sizes —  $3\frac{3}{4} \times \frac{1}{4}$ ,  $3\frac{3}{4} \times 3-16$ , and  $3 \text{ 11-16} \times 3-16$ . Other sizes available soon.

Manufactured exclusively and distributed by

### LAMONTAGNE LIMITED

Wholesale Dealers in Automotive Equipment

QUEBEC

MONTREAL

WINNIPEG

## YOU TELL 'EM!

**M**OST—if not all cars—furnish tool-kits as standard equipment containing tools for practically every purpose.

Yet, you can tell every automobile owner, every chauffeur who enters your place that his outfit is not complete unless he has a

# “HEXALL”

Trade Mark Reg. U. S. Pat. Office

## Socket Wrench

For speedy repair to out-of-the-way parts; for thorough and dependable use under all road conditions; for consistent, long and satisfactory service—*there is none to equal “HEXALL.”*

Seven sets—a “HEXALL” for every need—sold under this guarantee:—

**“Break any Sedgley Wrench and We Repair it—No Charge”**

No car comes standard-equipped with a much-needed accessory—a revolver that is small enough to tuck away out of sight yet is instantly ready for an emergency; one that is SAFE, with every desirable feature of its big brothers and none of their handicaps.

The “BABY” Hammerless Revolver fills this need. It measures only 4 inches overall; weighs but 6 oz., and shoots 6, sureshot, .22 calibre, short, rimfire cartridges. Hammerless; has folding trigger and interchangeable parts.

### R. F. SEDGLEY, Inc. Est. 1897

2311-13-15 North 16th St., PHILADELPHIA, PA.

Canadian Distributors: Lamontagne, Limited, Montreal, Canada.

Harold F. Watson Co., Sole Agent: 208 Coristine Bldg., Montreal, Canada.



“HEXALL” Ratchet Socket Wrench No. 1—16 pcs.



“HEXALL” Ratchet Socket Wrench No. 2—11 pcs.

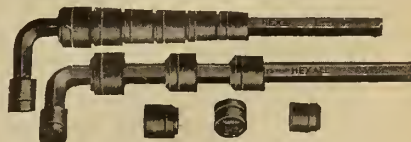

“HEXALL” Socket Wrench No. 5—8 pcs.

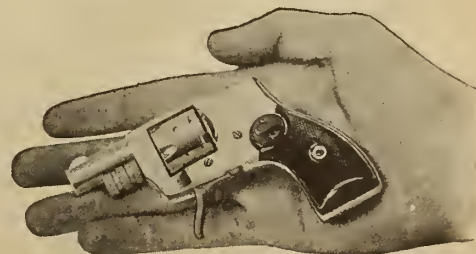



## The Plug with the Hotter Spark

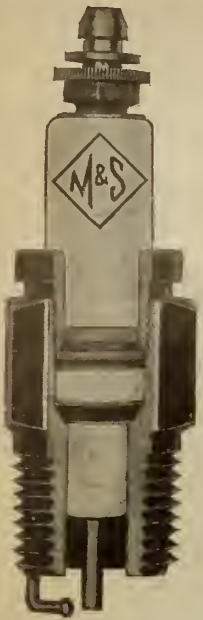

The ball point of the "M&S" spark plug concentrates the current and intensifies the heat. This gives a sure, hot spark—producing better combustion and greater power.

The "M&S" plug is made in all styles to suit every make of car—it is standard equipment on the popular new Overland "4."

The "M&S" plug is made in Canada and guaranteed to give complete satisfaction.

Dealers:—Ask your jobbers for the "M&S" plug.



### SPARK PLUGS

"Made-in-Canada"

No.	Models
500	—1/2" Standard
501	—3/8" Standard
502	—7/8" Long
503	—7/8" Long with Chevrolet Terminal
506	—1/2" Long
504	—Regular Porcelain
505	—Chevrolet Porcelain

Machine & Stamping Company, Limited  
1209 King Street West, Toronto, Ontario  
Commercial Dept., Russell Motor Car Co., Limited

# MALLEABLE CASTINGS for TRACTORS

## The Pratt & Letchworth Co., Limited

General Sales Office;  
Transportation Building  
Montreal



## PERFEX

### THE PERFECT RADIATOR

Direct cooling systems of highest quality, built by specialists. Efficient service guaranteed by nine years of past performance. Submit your specifications. Our engineering department is at your service.

PERFEX RADIATOR COMPANY  
FLETT AVENUE RACINE, WISCONSIN

# PERFEX

THE PERFECT RADIATOR

# Simplicity

FARMERS appreciate simple construction in an engine. They know that simplicity means more power, longer life and freedom from engine trouble.

Note the design of Simplicity Engines. Clean-cut, strong, powerful. No complicated parts to break and get out of order. Everything in full view—easy to understand and adjust.

Sizes—Gasoline, 1 1/2 to 16 H.P.; kerosene, 3 to 16 H.P.; stationary, skidded or portable.

Send for Price List and Catalog

THE TURNER TRACTOR SALES CO.  
WINNIPEG, MAN.

POWER FARM MACHINERY CO.  
EDMONTON, ALTA.

THE TURNER MANUFACTURING CO.  
441 LAKE STREET, PORT WASHINGTON, WIS.

Export Dept.  
44 Whitehall  
St., New York  
City

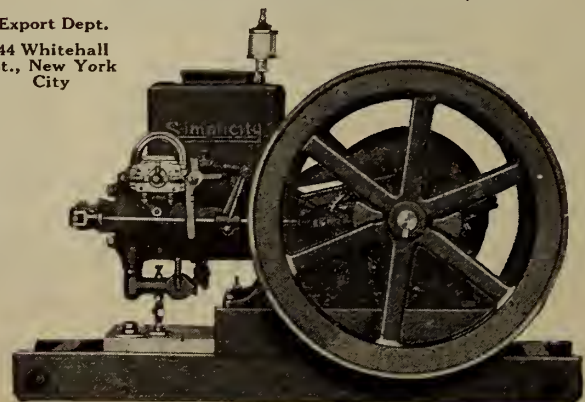



# NEWS — OF THE TRADE FOR THE TRADE

## ONTARIO

**TORONTO**—The H. C. Tomlin Company, 791-793 St. Clair avenue, has been appointed Chevrolet dealers.

**HAMILTON**—Hamilton officials are agitating to have the 20-mile-an-hour speed limit reduced to 15 miles.

**PETERBORO**—Edgar Burnham has secured the Oldsmobile agency for Peterboro and district.

**AURORA**—J. Fleury and Sons are planning the erection of a large addition to their moulding shop.

**ST. THOMAS**—The Elgin Garage has been sold by C. Maguire to Ford Willis.

**CHATHAM**—Incorporation is announced of the North Shore Motors, Ltd., with a capital stock of \$45,000.

**WALKERVILLE**—The Wilt Twist Drill Co., Ltd., is now making a complete line of Ford reamers.

**LONDON**—The crops in Western Ontario are exceptionally good this year. On some farms crop records have been established.

**BRIDGEBURG**—When a motor truck upset on the Niagara Boulevard, near here, several people attending a picnic were injured.

**WESTON**—Graham and Carton's new garage was used recently by the Weston Horticultural Society for its tenth annual exhibition.

**HAMILTON**—Erection of a wire fence plant is planned by the Steel Company of Canada to cost approximately \$250,000.

**WINDSOR**—Several factories connected with the automobile industry have closed down for two weeks on account of the annual stock-taking.

**HAMILTON**—H. W. Hutchinson, vice-president of the Sawyer-Massey Co., visited Minneapolis and other cities in the Western States recently.

**WINDSOR**—Woollatt and Lovelidge, Ltd., has been incorporated with a capital stock of \$50,000 to manufacture automobiles, trucks, tractors, etc.

**WIARTON**—An up-to-date garage and service station will be built here by Hay and Hoover, local agents for Gray-Dort Motors.

**ST. CATHARINES**—Fruit growers from this district are shipping their fruit by motor truck to Toronto with much success.

**TORONTO**—The Oak Tire and Rubber Company, Limited, has been incorporated with a capitalization of \$3,000,000. Head office is in Toronto.

**BRANTFORD**—The Brantford Washing Machine Company, Limited, has been incorporated with a capital stock of \$100,000.

**HAMILTON**—The incorporation is announced of Electric Stampings, Limited, with an authorized capital of \$100,000.

**TORONTO**—The Bailey-Drummond Motor Company, Limited, has been incorporated with capital authorized at \$100,000. Head office is in Toronto.

**KINGSTON**—The Kingston Street Railway Company, it is expected, will ask the City Council to allow it to establish a straight five-cent fare for all passengers.

**ST. CATHARINES**—While preparing to start a gasoline engine recently, George Goffin, aged 57, manager of the Martindale fruit and stock farm, dropped dead.

**MIDLAND**—J. L. Craighead, automobile dealer, has added to his line mowers, cream separators and all other farm implements. His garage is situated on Bay Street W., and is well equipped.

**STRATFORD**—The City Council at a special meeting, recently, passed a by-law for the purchase of a motor-driven hook and ladder waggon at a cost of \$11,450.

**BELLEVILLE**—Wilson and Hubbs, implement dealers, have had a very successful year. They carry a large line including tractors, engines, threshers, etc.

**TILLSONBURG**—A. A. Rea, issuer of motor licenses for Oxford County, reports that up to July 28 some 3,200 licenses were issued in Oxford county.

**TORONTO**—The Wychwood Garage, at 1415 Bathurst Street, has been purchased by J. T. Brownridge, of Brampton and J. A. Barber, of Winnipeg, from Crozier Coulter for \$47,500.

**BRANTFORD**—The Cockshutt Plow Company will make an addition to its blacksmith shop, for which a building permit has been taken out for \$45,000.

**ST. CATHARINES**—Ajax Wire and Wheel, Ltd., Canadian manufacturers of Honk and House quick change wire wheels, are erecting a large factory here with about fifteen thousand feet of floor space.

**WINDSOR**—The local branch of the Humane Society may be abandoned, it is reported, because there is nothing for its officers to do. Automobiles and motor trucks have almost entirely eliminated horses from the streets of the city.

**WELLAND**—The Joseph Stokes Rubber Company, of Trenton, N.J., has decided to erect a factory here for the manufacture of hard rubber goods, plates and cells for batteries, etc. Work on the new factory will commence immediately.

**TORONTO**—Kenneth MacKinnon, formerly a salesman with the Toronto branch of the McLaughlin Motor Car Co., Ltd., has been appointed manager of the Sales Department of British and American Motors, Ltd., formerly Wolseley Motors Ltd., Avenue Road.

**LEFROY**—U.F.O. members with their families and friends celebrated Dominion Day by a monster picnic held at Killarney Beach near Lefroy. It was estimated that there were in the neighborhood of seven hundred automobiles on the grounds.

**KITCHENER**—Local motorists are complaining about the recent amendment to the traffic by-law, which limits the parking of automobiles on King Street to two minutes. An effort will be made to have a modification of the restrictions.

**BLENHEIM**—Reeve J. A. Cameron, of Harwich township, completed his wheat thrashing a few days ago and had from the machine 3,100 bushels. This is the product of 105 acres. Besides this crop he has a large acreage of oats, corn and tobacco.

**STRATFORD**—D. J. Moore, of Ellice township, was fatally injured recently while assisting in thrashing on W. Bean's farm in Fullerton township. While adjusting a belt on a thrashing machine his arm was dragged into the machinery and badly mangled. He died before medical aid could be secured.

**PETERBORO**—The Raybestos Company, of Bridgeport, Conn., brake lining manufacturers, who were incorporated recently to do business in Canada as the Canadian Raybestos Company, with a capital stock of \$250,000, has purchased the Lundy tool and shovel factory and has equipped it to manufacture their product. Canadian sales headquarters are at 131 King Street, W., Toronto.

## THE BEST BUMPERS OBTAINABLE

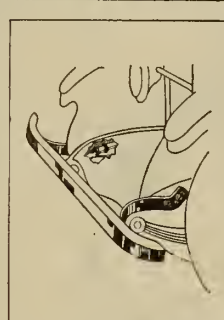

"KABEE"  
SPRING ARM CHANNEL  
BUMPER

"LYON"  
RESILIENT BAR  
BUMPER

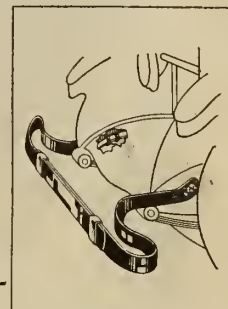

DURABLE BRILLIANT FINISH  
PATENTED "HOOKBOLT" ATTACHMENT  
FITS 90% OF STANDARD CARS  
OBTAINABLE FROM JOBBERS & DEALERS  
CATALOGUE ON REQUEST

**KINZINGER BRUCE & CO. LTD.**  
NIAGARA-FALLS, CANADA  
SOLE MANUFACTURERS UNDER  
LYON CANADIAN PATENTS.

Which  
is  
Safer  
Driving?

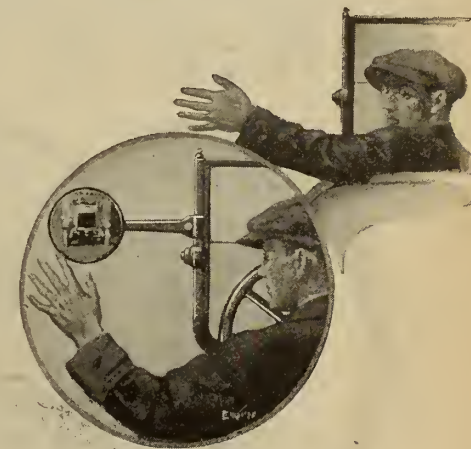

Driving with no means of viewing the rear traffic except by twisting around in your seat each time you wish to stop or turn—or watching every object in the rear with a convenient, clear vision Kales "Hindview" Auto Mirror?

## KALES

### *Hindview* Auto Mirrors

are guaranteed to be perfect in workmanship—are built to outlast your car—have many exclusive features of convenient adjustment. A style for every car and truck.

*Dealers are finding the Kales "Hindview" an exceptionally profitable accessory. In Ontario, every motor truck must be equipped with a mirror. Let us tell you more about the Kales "Hindview" features.*

Manufacturers of Metal Stampings, Washers and Card Holders  
**KALES STAMPING CO., Limited**  
61 Walker Road, Walkerville, Ontario



**Aikenhead's**

"The Sign of Better Service"

## GREB WHEEL AND GEAR PULLER

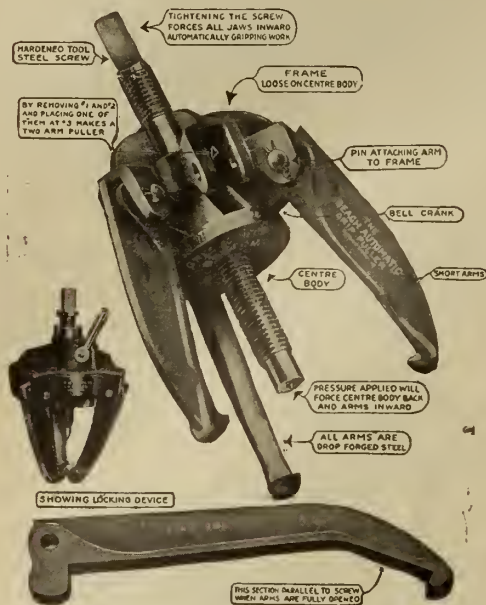

Quick, strong, durable, efficient, and can be locked in any desired position. Positive grip, cannot unhook, and adjusts to work. Long arms are also furnished.

Made in Three Sizes—

JUNIOR, INTERMEDIATE, and SENIOR

**Aikenhead Hardware Limited**  
TORONTO, CANADA

### SPECIAL APPLIANCES FOR EXPEDITING AUTOMOBILE PROCESS

(Continued from page 22)

ton is pushed into the cylinder. The binder remains with the lower edge on the top edge of the cylinder, and, of course, drops off when the piston is completely inserted.

#### Spicer Universal Companion-Flange Puller

This puller facilitates the removal of companion flanges on any Spicer universal, which flange is forced onto the gearset mainshaft and rear-axle pinion shaft to insure a perfect fit.

#### Valve-Tappet Adjusting Wrench

The wrench is designed to hook the tappet from the back. The design of the wrench gives more strength than is found in the conventional type. It is particularly applicable to the Hudson because of the lack of clearance between the valve tappet and tappet-guide clamp.

#### Valve-Reseating Tool

The tool illustrated is easy to operate and is valuable in truing up the valve seats after the motor has seen considerable service.

#### Piston Alignment Fixture

This device consists of a standard cylinder block cut in half. To use, it is bolted to the crank case and gives an efficient means of lining up the pistons in re-assembling a motor.

#### Connecting-Rod Bending Fork

This may be used in conjunction with the piston alignment fixture for lining up pistons. The slot is slipped over the arm of the connecting-rod and the leverage is sufficient to bend the rod any desired amount.

#### Oil Reservoir Drain Plug Wrench

This wrench is made of ordinary stock of cold-rolled square steel and is used to remove oil reservoir drain plugs.

#### Valve Lifter

This lifter is forged out of machine steel. It is equipped with a slip ring so that, if necessary, the valve spring may be held in a compressed position. It may be used in practically any motor with the valves on its side.

#### Cylinder - Plate and Generator - Screw Driver

A powerful driver has many uses in any repair shop. The one illustrated is designed particularly for use on valve covers and generator-field coils, but may be put to a number of other uses where good leverage is required.

#### Radiator Outlet Hose Clamp

This simple tool greatly assists in getting the hose line started back onto the water pump when installing a demountable radiator.

#### Carburetor Packing Nut Wrench

Gasoline mileage is often reduced because of leakage around the feed regulator of a carburetor. Tightening the gland forces the packing closer around the adjusting sleeve and prevents leaks. This wrench is made for that purpose.

#### Gasoline-Tank Gauge Clamp Wrench

Tank gasoline gauges are often held in position by a knurled cap which is tightened securely in place at the factory. Such a tool as the one illustrated is required to remove it.

#### Cylinder-Head Lifter

In removing a cylinder head it is often the case that some of the studs bind. Necessary variation of manufacturing limits create this condition. The removal of the head may be greatly facilitated by the use of lifter such as the one illustrated.

#### Piston Chuck

After an internal combustion engine has run for a period of six months to a year, depending upon the amount of use it has received, the piston rings will wear the ring grooves in the pis-

ton, so that it is necessary to true the ring grooves, eliminate the shoulders formed at their base and to fit new piston rings to secure maximum engine power and to keep the engine from pumping oil. The ordinary method of doing this by taking the piston off of the connecting rod and chucking it in a lathe is of course a practical method but one that requires considerable time, as the pistons must be removed from the rods before they are placed in the chuck and afterwards re-assembled when the job is completed.

The new piston chuck illustrated makes it unnecessary to remove the wrist pin and connecting rod from the piston, as it may be chucked in the special fitting with these parts in place. Another advantage is that trouble from cracking the piston, as sometimes occurs when the ordinary form of lathe chuck is used, is prevented. The construction of this device and the method of using it can be readily ascertained by referring to the clear illustration herewith.

### SELLING IMPLEMENTS BY HUMAN APPEAL

(Continued from page 13)

slightest notion. The uncertainty surrounding Hydro is even affecting their ordinary engine sales. Until this matter is settled one way or the other the dealers in that territory will suffer in this important branch of their business.

It is the policy of Wilson and Hubbs to sell well ahead of the time when the machines will be needed. In this way they have a reasonable assurance of delivery at the proper time.

There is one price for everybody and every machine is priced in plain figures.

Wilson and Hubbs practise courtesy and use a great deal of diplomacy. The farmer's wife is never ignored. In fact she is recognized by them as being the farmer's right hand man, so to speak; the chief counsel at all times. Even through the children can the heart of the doorest farmer be reached. Not long ago a farmer came into their warehouse accompanied by his little boy. They tried to sell him something but he seemed to be too grouchy even to talk. Just as he was about to go Mr. Hubbs, who is fond of children, spoke to the little boy, patted him on the head and gave him a "nickel." This was done in a simple and natural way without any design whatever other than just pure kindness toward a child. The farmer immediately capitulated, much to their surprise, and before he left the store he had bought several hundred dollars' worth of goods.

This business is conducted along rational and human lines. The appeal to the human side never fails. There is something in this for every dealer. By studying the prospect, being courteous at all times, selling a real utility, giving the best service, Wilson and Hubbs have made a sure place for themselves on the power farming map.

### B. C. LICENSE RULES

**W**H. HANDLEY, of the British Columbia provincial police motor license office in the court house reminds motorists that under the new regulations all old forms for applications, renewals and transfers are cancelled. New forms as authorized by the regulations can be obtained at the provincial police office. Mr. Handley also issues a reminder that there is now a statutory fee of one dollar for transfers, a fact that several applicants since the new regulations came into effect were unaware of.

The reduction of the license fee in proportion to the number of months yet to run, when a new license is taken out, in no case reduces the fee to less than \$10. Thus, a new license taken out now at the rate of \$15 for the year would not be \$7.50, but \$10, although the reduction on a license costing \$20 or over would be 50 per cent.

## The Heart of Your Car

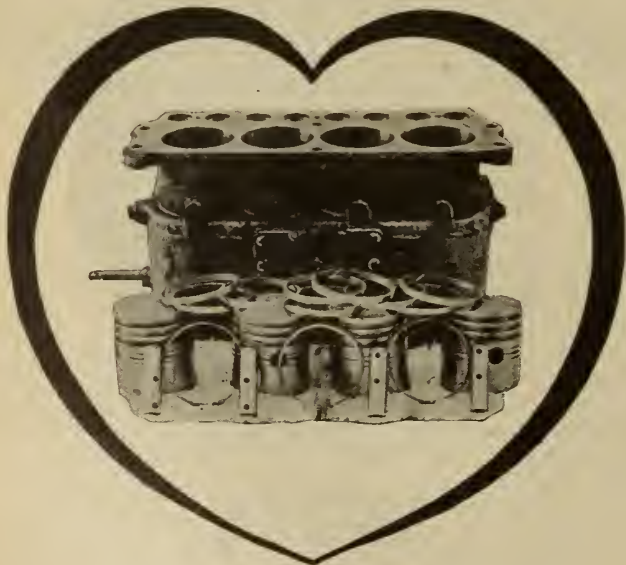

We regrind Cylinders, make Pistons, Rings and Pins, with special equipment adapted for this purpose. Also parts to order.

*We Do Oxy-Acetylene Welding*

**Advance Machine & Welding Co.**

177F Canning Street, Montreal



# Make Your Garage More Efficient

## Motor Stand

For all Makes of Automobile Engines

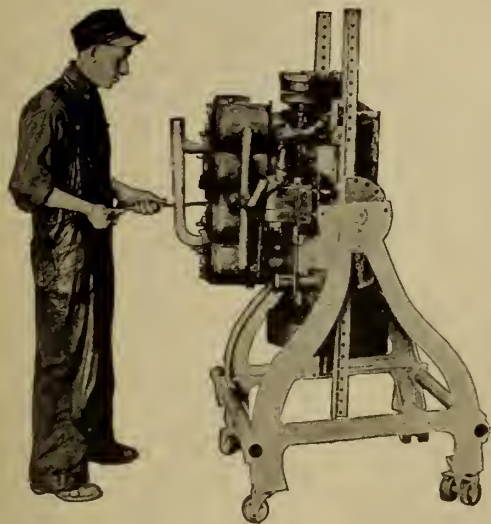

This Motor Stand is manufactured under basic patents, and is the only stand of its kind permitted to be manufactured that can be securely locked at any desired position or angle, and changed and locked as desired.

This permits the mechanic to arrange the motor in just the position where he may obtain the best light and where he may get to the part he is working on with the most ease.

It is a universal stand and will handle all types of motors, including Fords.

No. 6123—Price, Universal Motor Stand ..... \$97.50

The Weaver Auto Ambulance is the only thoroughly practical and universal device ever perfected for pulling disabled cars into the repair shop. Readily attached to either axle of the car; easily handled by one man; quickly adjusted to meet every contingency; comparatively light, but amply strong; telescoping tongue.

## Weaver Auto Ambulance

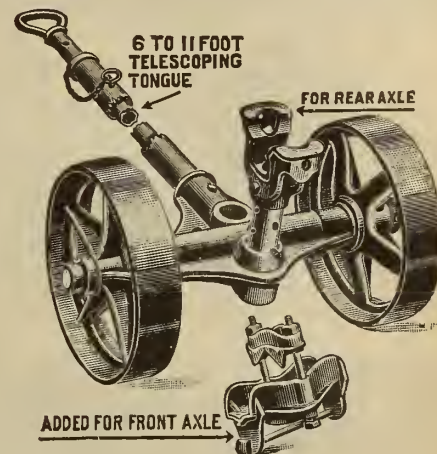

The wheels are of cast steel and very strongly designed. 14 inches in diameter with 3-inch face. Can be used on country roads with entire satisfaction. **Broad Roller Bearings** permit heaviest loads to be towed with little energy.

**General Construction.**—The construction throughout is extremely strong but designed so as to eliminate all unnecessary weight. The telescoping tongue is of **double** strength steel tubing; 1 1/4-inch steel axle extends entirely through the frame; malleable iron saddles; 20 in. tread; shipping weight, complete, 145 pounds.

No. 6115—Price, Weaver Auto Ambulance, Net .. \$51.75

**HYSLOP BROTHERS LIMITED, TORONTO, ONT.**

# He has more money now

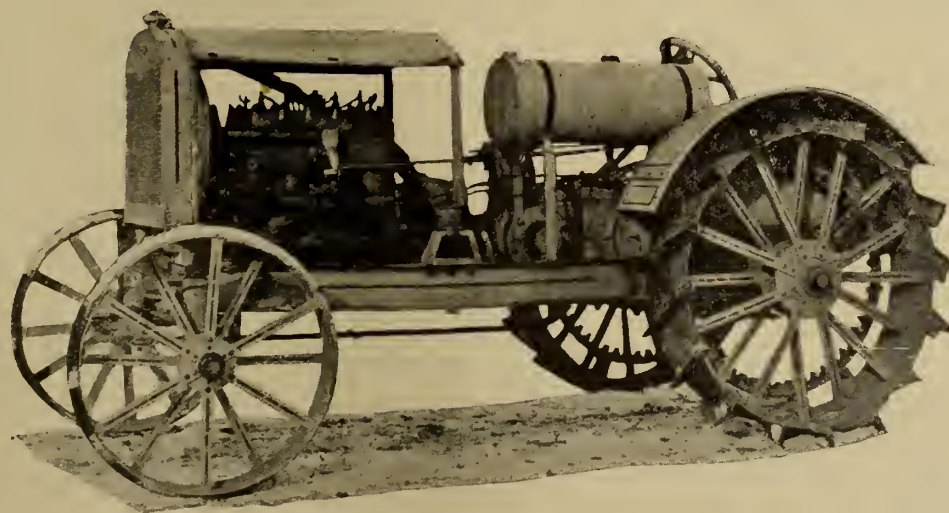

Don't put it off any longer. Link up with the "Essex" Tractor without delay. In the matter of tractor sales the Fall can be made a time of harvest for the "Essex" Dealer.

Mr. Farmer is commencing to collect dividends on his year's work. Ready money is coming in in fairly large sums. He feels prosperous, he will listen to suggestions tending to lessen his labor for the following year.

It's the time to sell him an "Essex."

In the "Essex" you have a proposition that instantly appeals to the practical farmer. There is a great deal of farming experience incorporated in the "Essex"; it is just the sort of tractor a farmer with mechanical ability would build.

Ask us to tell you all about the "Essex" and the lucrative "Essex" Agency.

**ESSEX TRACTOR CO., LIMITED, Essex, Ontario**



# BIRDSELL CLOVER HULLERS

Best for Threshing,  
Hulling and  
Cleaning

Little Red or Common Clover Seed  
Big English or Mammoth Clover Seed  
Alsike Clover Seed  
Sweet Clover Seed



### THREE SIZES FOR CANADA

No.	Cylinders	Capacity	Power Required
No. 2	Cylinders 27" x 32"	Capacity 3 to 5 bushels per hour,	6 to 8 H. P.
No. 1	Cylinders 30" x 36"	Capacity 5 to 7 bushels per hour,	8 to 10 H. P.
No. 8	Cylinders 40" x 52"	Capacity 7 to 10 bushels per hour,	10 to 12 H. P.

WE HAVE A SIZE TO SUIT EVERY NEED

## ANN ARBOR HAY PRESSES

If in the market for a Hay Baler we can furnish in any size to meet your requirements. Write us or call and see us while in the city.

## Birdsell Manufacturing Co.

Foot of George Street  
Toronto, Canada



## It Docks at Your Desk

Our service brings to your desk news items collected from the newspapers relating to your line of business.

Often you plan your affairs on market conditions or new developments, but you could plan much better with all information before you from the whole of Canada.

These newspaper clippings have proved most valuable to business houses, saving time in searching files and often being turned to good account, getting contracts and orders.

We cover all parts of Canada and United States and read for all subjects discussed in the press.

Have the news packets arrive regularly at your desk with a cargo of timely news.

Canadian  
Press Clipping Service

143-153 UNIVERSITY AVE., TORONTO

## Dairy and Household Supplies

### SOME DON'TS IN SEPARATOR OPERATION

**DON'T** wash the bowl housing or any part of a separator frame with a wet dish cloth. A dry cloth, or preferably one saturated with a little separator oil, will prevent the possibility of getting moisture into the gears and preserve the enamel on the frame.

Don't put wet, dripping tinware and bowl parts in supply can and replace it on frame with open faucet directly over the bowl spindle; it's apt to get moisture into the gearing and cause rust.

Don't flush a separator with scalding hot water; it cooks the milk solids on to the tinware instead of washing them off. Water a little warmer than new milk is preferable.

Don't remove the covers and stop the bowl after separating. The bowl and spindle may be injured by so doing—let it stop by itself.

Don't attempt to turn a separator until the oil chamber has been filled with separator oil. A separator may be ruined if permitted to run dry.

Don't wash cream separator tinware with any gritty scouring compound; it means ruin to the tin plating.

Don't assemble bowl parts until ready to separate.

Don't turn milk on until separator is up to speed.

Don't install a separator in a basement if it can be avoided. Basements are usually damp. Better fix a separator room in some dry place.

Don't hammer the exposed threads on the tubular shaft if the bowl shell sticks after separating. Unscrew the bowl nut part way, hold it in the left hand and strike the nut on it with the palm of the hand. This method will prevent injury to the threads on the tubular shaft.

Don't start a new separator without first flushing the gears with kerosene.

### FARM LIGHTING SYSTEM

**O**NE of the United States agricultural colleges issued a bulletin recently on farm lighting plants from which the following extract is taken:

One of the most important farm home conveniences is a good lighting system, a system which will do away with the dirty, ill-smelling kerosene lamp, which is a constant source of danger, is inconvenient, inefficient, and a care to the busy housewife, says E. W. Lehmann, of the University of Missouri College of Agriculture.

Conditions change from year to year and what were considered luxuries a few years ago are now considered necessities. This is particularly true with reference to conditions on the farm. Things are no longer "all right because our fathers got along with them." The up-to-date farmer must have his home equipped with all modern conveniences, not only because they add to the pleasure of living, but also because they make him more efficient in his farm work.

### THE VEGA CREAM SEPARATOR

**T**he Vega Cream Separator, manufactured at Eskilstuna, Sweden, was recently introduced into the north-western territory by Munson-Thompson, Inc., Minneapolis. A unique departure from the standard American separator is the small sized machine which is manufactured for the use of farmers who have but few cows. The capacity is but 150 pounds per hour, and parts are in direct proportion to this small size. The largest machine

has a capacity of 900 pounds. The driving mechanism is unique. Only two gears are used, the first of which engages with a worm on the shaft on which the second is mounted, and the second engages with a worm on the shaft on which the bowl and discs are mounted. The first gear is somewhat larger than the second and in that way steps up the speed to the proper point for efficient skimming. The bowl is self balancing and is hung so that it will come into balance when full speed is attained.

### A NEW DISC FOR CREAM SEPARATORS

**H**ERETOFORE all discs in cream separators have been of the cone shape design. The whole milk flowing in at the top has had to travel downward, between these numerous discs placed but 1/8-inch or less apart

Naturally, with the extreme velocity, and due also to the fact that both milk



and butter-fat particles enter at the extreme edge of the discs, not all of the butter-fat particles get out of the way, or, in other words, back up against this tremendous pressure, and are therefore carried along and out into the "skim-milk." This causes quite a loss of cream.

The Swedish Separator Company, Chicago, is marketing what is known

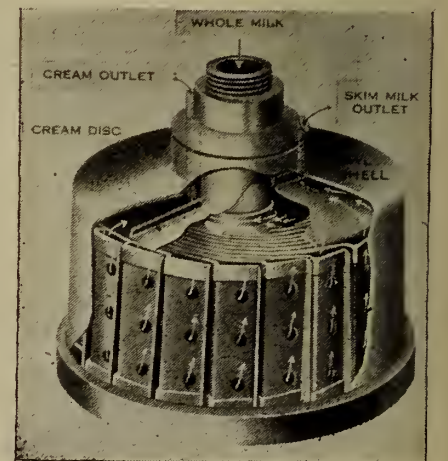

as the "straight disc;" the whole milk flowing first to the bottom and then entering each disc at its centre, which gives the butter-fat particles (B) a chance to slip back towards the cream outlet, and out of the way of the heavier milk particles (A), thus producing a separation that the Swedish Company guarantees to lose but 3-100 of 1 per cent., or less.





# The Creed of a De Laval Traveler

The following creed was sent in voluntarily to The De Laval Company by a De Laval Division Superintendent, and was first published in the De Laval monthly.

**I BELIEVE** in the De Laval Cream Separator, because in its making the greatest accomplishments in modern centrifugal cream separation are embodied.

I believe in the De Laval Cream Separator, because I know beneath the lustre of its furnace-baked enamel is the expression of honesty and integrity, from the sanitary base to the seamless supply tank.

I believe there is bound up within the matchless frame a polished gearing that proclaims the standard throughout the world; and in offering the De Laval to the dairyman, I know I am selling a machine constructed of materials and character that reflects its superiority by the continued expressions of satisfaction from its users.

My faith is not alone in the machine. It is also in the ideals of the men who are responsible for the success of the Company, for I know that back of the large factories, the ever-present thought in the minds of these men is continually to evolve new and better methods of cream separation, and to render the best possible service to the user.

And so I stand in my conviction that honest goods can be sold by honest methods, and with this truth as my guiding star, I will through honest effort uphold the policy of these pioneers, by selling a machine built by honest effort and of honest materials, to be sold by straightforward, manly methods.

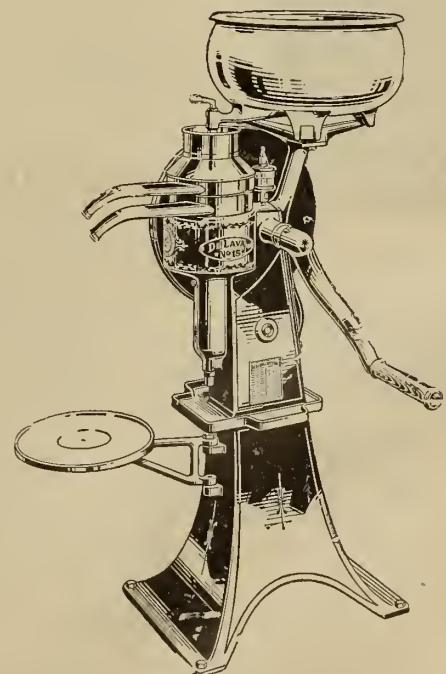

**THE DE LAVAL COMPANY, LIMITED**

MONTREAL    PETERBORO    WINNIPEG    EDMONTON    VANCOUVER

50,000 Branches and Local Agencies the World Over



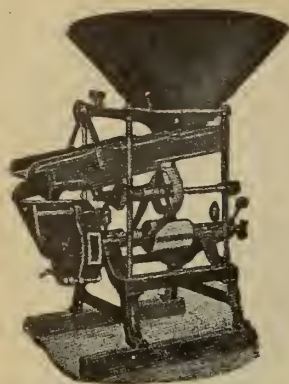

## If you could find the equal of "Vessot" Grinding Plates

You might find a Feed Grinder as good as the "Vessot." As yet no

other manufacturer has been able to construct plates that approach the "Vessot" in grinding efficiency and wearing qualities.

Note the trade-mark "SV" cast in the plate. Nine different sizes from 6 1/2 to 15 inch.

Get the "Vessot" Agency Plan from the nearest branch of the International Harvester Company. It will surely interest you.



Invented and Manufactured by  
**S. Vessot & Co.**  
JOLIETTE, QUE.

Sold Exclusively in Canada by  
**International Harvester  
Co. of Canada, Limited**

Branches: Calgary, Edmonton,  
Lethbridge, North Battleford, Regina,  
Saskatoon, Yorkton, Brandon,  
Winnipeg, London, Hamilton, Ottawa,  
Montreal, Quebec, St. John.



Grinder with Elevator and Bagger

## A 24-Hour Radiator Repair Service



Why fuss with troublesome radiator repairs? They can be more cheaply and effectively executed by the manufacturer.

Ship any make to our Repair Department and in 24 hours, or less, it will be on its way back to you—freight or express as you instruct.

We promise you no wait service and A No. 1 workmanship.

**McCord Mfg. Co.**  
WALKERVILLE, ONTARIO



Tool Locked in Position  
for Removing or Replacing Tire

**K.P. Universal  
Rim Tool**

The easiest way to remove tires from split rims. Collapses, holds rim collapsed while changing and forces the rim back on tire again with utmost ease.

PRICE \$6.00

Sold by

**Northern Electric  
Company, Limited**

Montreal Ottawa London Regina Edmonton Toronto Winnipeg Calgary Vancouver  
K. P. Products Company, Inc., 250 West 54th St., New York City

## News of the Trade

### QUEBEC

**SHERBROOKE.** — N. N. Walley has sold his garage to H. Veilleux, who in turn sold it to Messrs. Hebert and Fortier of East Sherbrooke.

**QUEBEC.**—Eugene Julien, founder of Eugene Julien and Co., Limited, vehicle and feed merchants, died recently at the age of 44 from an attack of typhoid fever.

**MONTREAL.** — The Automobile Club of Canada has been advised by the agent of the Grand Trunk Railway that, for the convenience of patrons crossing Victoria Bridge by automobile, tickets can be purchased at the city ticket office, 230 St. James street and at the Bonaventure Station ticket office. This will enable motorists to secure tickets in advance.

### MANITOBA

**PORTAGE LA PRAIRIE.** — A new concern, the Portage Auto Top Co., has commenced business here.

**WINNIPEG.**—Motor busses will be used here to combat the increased street car fares.

**MINNEDOSA.** — A new implement concern has opened here under the name of Londry and Scott.

**WINNIPEG.** — Winnipeg Motor Cars Ltd. has been incorporated with a capital stock of \$1,000,000.

**BRANDON.** — A fire recently caused considerable damage to the plant of the Currie Mfg. Co., manufacturers of fanning mills.

**WINNIPEG.** — W. White, formerly manager of wholesale sales for Breen Motor Co. has been transferred to that firm's Chevrolet showroom at 391 Portage avenue, as manager.

**WELLWOOD.** — A tractor and automobile repair business has been opened by J. R. Thomson. It is equipped to do all manner of repairs on cars and tractors.

**MINNEDOSA.** — Wilkie Grant has opened a general automobile and tractor repair establishment. He will do all kinds of repairs including acetylene welding and cutting.

**WINNIPEG.** — The Parker Motor Car Company, Limited, has been incorporated with an authorized capital of \$3,000,000. The incorporators are F. W. Louthood and R. E. Ford, accountants and W. A. Deacon, barrister-at-law, and others.

### SASKATCHEWAN

**SASKATOON.** — The Universal Tire Filler Co. has been incorporated.

**MOOSE JAW.** — A large oil refining plant will be erected here by the Western Oil Co., Ltd.

**SASKATOON.** — The Imperial Oil Co. will erect a station here to cost approximately \$100,000.

**LOREBURN.** — G. Baldwin, implement dealer, has sold his business to W. J. Drummond.

**EASTEND.**—Messrs. Crawford and Jones have secured the agency for Ford cars.

**BENTLEY.** — An automobile and tractor repair shop has been opened here by Bjornson Bros.

**HIGH RIVER.**—A new implement business has opened up here conducted by W. H. Sanders.

**EDMONTON.**—Incorporation has been announced of the Western Tire and Rubber Works.

**EDMONTON.** — A new incorporation is the Northern Threshing Machines Limited.

**BAWLIF.**—Martin Molstad, implement dealer, has added an up-to-date garage to his implement business.

**ATHABASCA LANDING.** — G. N. Kydd, a returned soldier, is an implement and power farming dealer here.

**WAPPELLA.**—Charles H. Clements, of the farm implement firm of Kidd and Clements, died recently at the age of 58.

**MOOSE JAW.**—The incorporation was announced recently of the Hilts Stooking Machine Co. with an authorized capital of \$10,000.

**YORKTON.**—The Yorkton Auto and Garage Co., has been selected by the Dominion Trails Association as its official garage in this district.

**SWIFT CURRENT.** — S. G. Farrell, of Gravelbourg, was instantly killed and James Grimes, of Ponteix, fatally injured recently as the result of an auto crash near here.

**LOUGHEED.** — W. C. Reed, Canadian Fairbanks-Morse agent here, has installed a 40-light Type "F" lighting plant in the town barber shop and pool room recently.

**SASKATOON.** — The directors of the Saskatoon Auto Club are planning to develop the Pike Lake resort and in order to secure the success of the scheme an important membership drive is being carried on.

**EASTEND.**—W. Wilton has sold half interest in his garage to C. Davis and the business will now be carried on under the name of Wilton and Davis. The new partners recently signed a contract for the Chevrolet agency.

**MILESTONE.** — The Milestone Garage has been purchased by S. Krozovski of Regina from J. E. Johnson and he will continue to operate a general repair shop. He will handle the Gray Dort car.

**WEYBURN.**—Clarke's Garage is the name of a new garage being built here. It is 50x100 feet, one storey, and is to cost in the neighborhood of \$10,000; brick, tile and cement, steam heated and equipped in the most modern way to do all kinds of repair work including vulcanizing.

### BRITISH COLUMBIA

**VANCOUVER.** — Knight Higman Motors Limited have moved to new quarters at 418 Georgia street.

**CAWSTON.** — J. T. Law, of Indian Head, has opened a garage here. Owing to difficulty in procuring a suitable building he is at present conducting his business in a tent.

**VICTORIA.** — Negotiations at present proceeding between the civic authorities and the B. C. Electric Railway Company make it practically certain that Victorians will be paying a seven-cent street car fare before many months have passed.

**VANCOUVER.** — The Britannia Wire Rope Co. is getting in shape to operate at their plant on Granville Island, B. C. The machinery for most of the plant is now on the way from England. C. H. Gill is the British director, and Robert Gibson managing director.

**NEW WESTMINSTER.**—A large cordage plant to be known as the Canada Western Cordage Co., Ltd., is to be established here. The stock will be owned by returned soldiers and the business will be conducted on a co-operative basis. The Government has loaned the company \$200,000 to be repaid in twenty years.



**WHAT THE TRUCK SALESMAN SHOULD KNOW**

(Continued from page 16)

The other is to assure a different book value of the truck at the end of each year. The first method is the simpler but it is only justifiable when an allowance for depreciation is not made. If a sinking fund is kept and accumulated each year the increasing amount of interest earned by it should counter-balance the reduction in the amount of interest charged against the investment because the value of the truck has depreciated for each year of its employment. In other words, the interest on the sinking fund plus the interest on the present book value of the truck should equal interest on the original investment.

Too many truck owners make insufficient allowance for depreciation, usually they are under the impression the trucks are being operated at a profit, but when new trucks have to be purchased the imaginary profits are converted into deficits. Repairs and depreciation charges should not be confused. Though repairs increase the life of a truck, the time will come when it will be more economical to buy a new truck than to continue spending money on repairs.

Rate of depreciation depends upon the class of work performed, roads, loads, speed, maintenance, and other factors. A truck operated with good care over paved roads or streets, without overloading, may last for eight or ten years, while the same truck carelessly operated, overloaded, over heavy roads may last only two or three years. In making his estimate of the annual amount to be allowed for depreciation and placed in a sinking fund, the operator should very carefully consider the conditions under which he gives his truck service.

The importance for making proper provision in truck costs for maintenance and fixed charges—especially the latter including insurance, interest, and depreciation—cannot be too greatly emphasized. The salesman who argues that his truck is the best because it will run more miles on a gallon of gasoline than any other truck, will not find his argument will convince the sound business man. In fairness to his own business and also to that of the prospective purchaser, the salesman should sell his truck because it will give the most efficient and cheapest service, all costs, operation, maintenance, and fixed charges considered.

**THE MOTOR TRUCK—AN ECONOMIC NECESSITY**

ASK the next ten men you meet what industry is the most vital to the nation, and every one of them will answer farming—raising food.

But the foodstuffs do very little good until they are transported to our cities, and transportation in this country is very badly demoralized.

The railways are short 700,000 freight cars and 4,000 locomotives. This equipment could not be built in the next three years, even if all railway shops were to work full blast. But even when this shortage of equipment is met there will not be enough rails to run it on. The railways are tied up, not only from the lack of cars and engines, but from a shortage of rails and adequate terminal facilities.

Think of it! The average freight car moves only twenty-five miles a day. This slow progress is due almost entirely to congestion. Relieve this congestion, and you can increase the average rate of travel to thirty miles a day.

This increase in travel would mean an equivalent of 600,000 cars, which would almost make up for the cars the railways are now short. The point is, the railways now get very little good out of the cars they have. What they want is less congestion.

There are 2,400,000 freight cars in use, and they can take care of the

# Northern Electric

## Profit-Producing Equipment for Every Garage



**HAYWOOD MODEL L VULCANIZER** handles each and every injury to which a pneumatic tire or tube is liable, including tread cuts, sand boils, fabric breaks, rim cuts, loose beads and blow-outs, and replaces small sections of worn tread. Its range is remarkable—**FIVE TIRES AND FOUR INNER TUBES CAN BE CURED AT ONE TIME.** The Model L will handle all the work two men can get ready for it. It will turn out \$75.00 worth of work in a day when operated to capacity.

With the Model L are supplied all necessary bead plates and clamps, and a set of working tools.

**TEMCO GARAGE OUTFITS**

eliminate handwork, thereby speeding up production. The outfit consists of the Temco Model B Portable Electric Drill with Emery Wheel and Valve Grinding Attachments, and comes with cord and attachment plug, ready for use.

A single control switch right near the handle starts, stops, and reverses the motor at any time.





**Curtis  
Air Compressors**

Pure Air for your customer means good service because oil ruins tires and, **AIR FREE FROM OIL**, means fewer blow-outs—fewer punctures—greater tire mileage—less repairs, saving the customer many dollars up-keep every month.

The CURTIS is the only compressor whose design and construction gives a guarantee for pure air—**AIR FREE FROM OIL.**

*Write our nearest House for prices and full details*

## Northern Electric Company

LIMITED

Montreal	Halifax	Toronto	London	Winnipeg	Calgary	Vancouver
Quebec	Ottawa	Hamilton	Windsor	Regina	Edmonton	

country's transportation, provided they are not held up by the short-haul business that is responsible for the present tie-up.

That's where the motor truck steps in. It must take the short-haul business—hauls up to sixty miles. The railways admit they lose money on hauls shorter than this distance and if they are to survive they must either raise freight rates to offset this loss or turn the short haul over to the motor truck.

But an increase in rates will not relieve this congestion; will not solve the problem.

The motor truck can and must solve it. The railways see this. They are not hostile to the truck.

The motor truck is not running in competition with the railways. It is

simply helping them out of a bad pinch, and turning the loss into a profitable business, which will solve one of the nation's most vital problems. Motor-truck transportation is one of the vital necessities of the country today.

In these days when bankers are not looking around to find some one to whom to loan money, they are supporting the motor-truck industry in a manner which indicates that they realize not only the growing demand for trucks but their absolute necessity.

The motor truck is a good investment. It pays for itself. It is a business proposition, pure and simple, and is helping solve the transportation problem that is one of the most serious considerations that the nation has to face at this time.

From "Service."



## AUTOMOBILE SPRINGS

**The Guelph Spring and Axle Co.**  
Guelph - Ontario  
Manufacture

**AUTO SPRINGS  
ALL KINDS  
HIGHEST QUALITY**



# FARM IMPLEMENTS THAT SELL THEMSELVES

No matter in what district you live, Massey-Harris Implements are known to every farmer. They need no introduction. They are known for their dependable quality, sterling worth, and soundness of construction. Their good qualities have won the confidence and goodwill of all who use them.

The year round they make it easy to win a livelihood from the soil. Plowing, seeding, mowing, reaping, harvesting and marketing are done with complete satisfaction by means of Massey-Harris Implements.

When a man needs a new machine, past experience with Massey-Harris Implements will guide him to choose another of the same line. Every Massey-Harris machine in use helps to sell another bearing the same name.

Address all applications for representation in vacant territories to the manager of the branch nearest you.

## MASSEY-HARRIS CO., LIMITED

Head Office - Toronto, Ont.

Branches at: Montreal      Moncton      Winnipeg      Regina      Saskatoon  
Swift Current      Yorkton      Calgary      Edmonton

WE GIVE

# “Quality and Service”

IN

## TRACTOR and TRUCK STEEL CASTINGS

### Joliette Castings & Forgings Limited

Head Office:                      Works:  
Transportation Bldg., Montreal      Joliette, Que.

### Good Position Open

One of Canada's largest and most aggressive manufacturing organizations desires to engage a representative between the ages of twenty-eight to thirty-five to extend present connections in special lines for the automotive industry; to introduce and develop special lines offering sufficient volume to justify mass production. Mechanical ability desirable but not imperative. The opportunities are unlimited for one with the necessary executive ability and initiative. Apply with full particulars of age, experience, and salary required to Box 100, Motor, Tractor and Implement Journal, 143 University Ave., Toronto, Ontario.

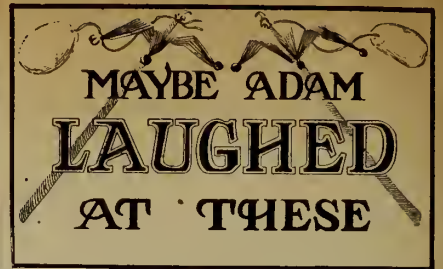

“I get a lot of fun out of my flivver.”  
“Then you're foolish to spend so much time in it.”—Boston Transcript.

\* \* \*

Friend (viewing picture) — “How realistic! It fairly makes my mouth water.”

Artist.—“A sunset makes your water?”

Friend.—“Bless me! I thought it was fried egg.”—Boston Transcript.

\* \* \*

“Mr. Jobbles,” said the head of the firm, “I notice there's a considerable item for meals in your expense account.”

“Er—I was entertaining customers and prospective buyers, sir.”

“All right. I'm not complaining, but I hope you will bear in mind that we are selling tractors, and no lady of the chorus ever buys a tractor.”

\* \* \*

The temperance reformer was justly proud of having converted the biggest drunkard in a Scottish town and induced him—he was the local grave-digger—to get up on the platform and testify. This is how he did it: “My friends,” he said, “I never thocht to stand upon this platform with the provost on one side of me and toon clerk on th' ither side of me. I never thocht to tell you that for a whole month I've not touched a drop of anything. I've saved enough to buy me a braw oak coffin wi' brass handles and brass nails, and if I'm a teetotaler for another month I shall be wantin' it.”

\* \* \*

Here is a new form of an old story: A small storekeeper put in his window not long ago an elaborate new blind. Quoth his neighbor: “Nice blind of yours, Isaac.” “Yes,” was the reply. “Who paid for it, Isaac?” “The customers paid.” “What? You say the customers paid for it, Isaac?” “Yes. I put a leedle box on my counter and labeled it, ‘For the Blind,’ and they paid for it.”

\* \* \*

Director.—“Charlie, we're going to take a movie of your laundry this afternoon.

One Lung.—“You crazy man! Nobody can make me move; me gotta lease.”—Film Fun.

\* \* \*

“It is becoming more expensive every day to run an automobile.”

“Yes,” replied Mr. Chuggins. “Some of us motorists won't be able to keep going unless the Government comes to the rescue the same as they did for the railroads.”—Washington Star.

\* \* \*

“And what is that lad of yours going to be when he grows up?”

“I rather fancy he'll be a golf cad-dy.”

“Really!”  
“Yes. The last tanning I gave him, he turned round and told me I wasn't holding the stick the right way.”—London Opinion.

\* \* \*

“Why do so many young men want to leave the farm?”

“Hadn't noticed that they do,” replied Farmer Cornrossel. “Most of 'm around here seems to have discovered that it is a heap harder to set without workin' in the city than it is at the dear old home.”—Washington Star.



# VETERAN

## MOTOR TRUCKS

*Built in Canada*

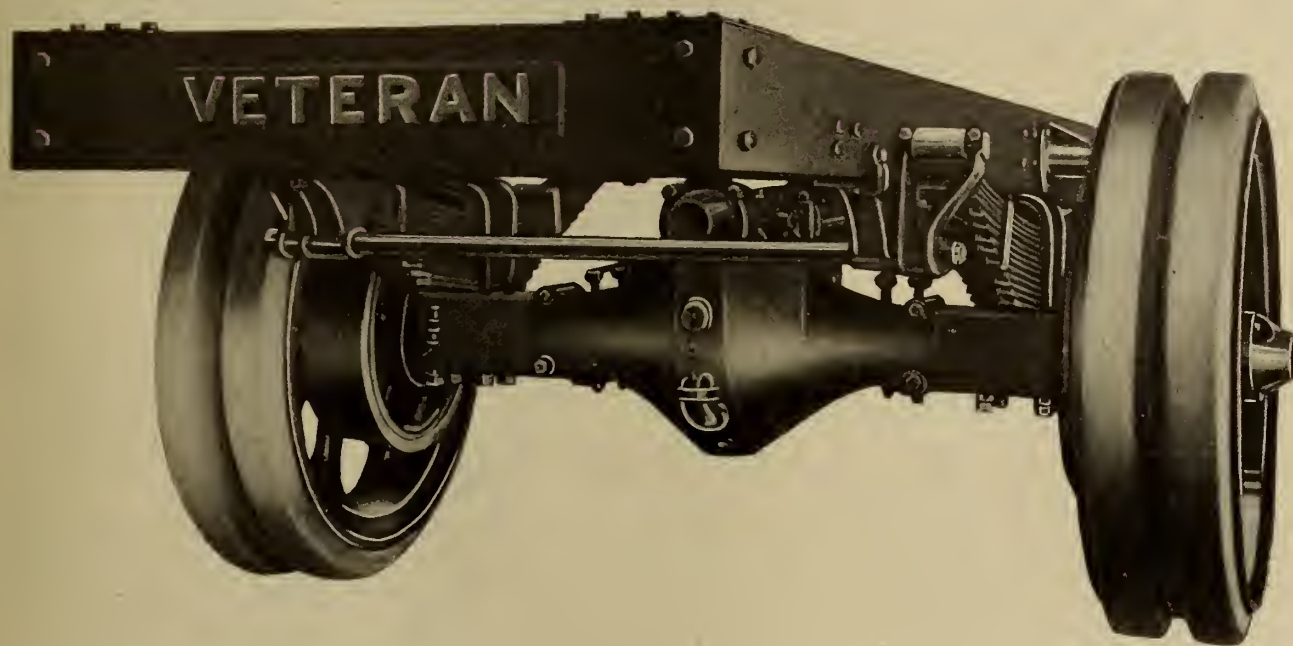

*The  
Best  
Truck  
Buy  
In  
Canada  
To-day*

The biggest expense of all *idleness* is practically eliminated in the *Veteran*. All that is required is fair treatment in the way of inspection and minor maintenance and your truck will give you *service at all times*.

*A Line to the Factory or Our Distributors Will Bring You Full Details.*

Distributors for Western Ontario, Manitoba, Saskatchewan, Alberta and British Columbia:  
Commercial Cars Limited, Toronto, London, Winnipeg, Vancouver.

### EASTERN CANADA MOTOR TRUCK CO.

Limited

HULL,

QUEBEC



# CANADIAN Motor Tractor and Implement Trade Journal BUYERS DIRECTORY

This directory will help you with your buying and your planning. The advertisers listed here are thoroughly reliable and leaders in their respective fields. They are looking for live, wide-awake representatives. Study their advertisements carefully because they contain valuable information which will dovetail with your plans. We are glad to go to the trouble of arranging this list—to make it easy for you to select new lines. If it so happens that what you want is not here, write us, and we will tell you where to get it.

## ACCESSORIES

Advance Machine & Welding Co., Montreal.  
Burlington Products, Ltd., Hamilton, Ont.  
Canadian Car & Foundry Co., Montreal, Que.  
Canadian Raybestos Co., Peterborough, Ont.  
Champion Spark Plug Co., Windsor, Ont.  
Guelph Spring & Axle Co., Guelph.  
Northern Electric Co., Ltd., Montreal.  
Apollo Plug Mfg. Co., Birmingham, Eng.  
R. F. Sedgley, Inc., Philadelphia, Pa.  
McCord Mfg. Co., Walkerville, Ont.  
Kinzingler Bruce Co., Niagara Falls, O.  
Aikenhead Hardware Co., Toronto.  
Hyslop Bros., Toronto.  
Kale Stamping Co., Walkerville, Ont.  
K. P. Products Co., 250 West 54th St., New York City.  
Lamontagne, Ltd., Montreal.  
Perflex Radiator Co., Racine, Wis.  
Wedgerite Piston Rings, Montreal, Que.

## AUTOMOBILE BUMPERS

Kinzingler, Bruce & Co., Ltd., Niagara Falls, Ont.

## AUTOMOBILE CHAINS

## AUTOMOBILE JACKS

Kinzingler, Bruce & Co., Ltd., Niagara Falls, Ont.

## BARN EQUIPMENT

John Deere Mfg. Co., Welland, Ont.

## BEEF MACHINERY

International Harvester Co., of Can., Ltd., Hamilton, Ont.  
John Deere Mfg. Co., Welland, Ont.

## BENDERS

The Frost & Wood Co., Ltd., Smiths Falls, Ont.  
International Harvester Co., of Can., Ltd., Hamilton, Ont.  
Massey-Harris Co., Toronto.

## BELTING

Canadian Raybestos Co., Peterborough, Ont.

## BATTERIES

## CARRIAGES

Cockshutt Plow Co., Brantford, Ont.

## CREAM SEPARATORS

De Laval Co., Ltd., Peterboro, Ont.  
International Harvester Co., of Can., Ltd., Hamilton, Ont.  
R. A. Lister Co. (Canada), Ltd., Toronto

## CEMENT MIXERS

## CASTINGS

Joliette Castings & Forgings Ltd., Montreal and Joliette, Que.

## CORN HARVESTERS

Cockshutt Plow Co., Brantford, Ont.  
International Harvester Co., of Can., Ltd., Hamilton, Ont.  
Massey-Harris Co., Toronto.

## CORN MACHINERY

International Harvester Co., of Can., Ltd., Hamilton, Ont.  
John Deere Mfg. Co., Welland, Ont.

## CULTIVATORS

Cockshutt Plow Co., Brantford, Ont.  
John Deere Mfg. Co., Welland, Ont.  
Massey-Harris Co., Toronto.  
The Frost & Wood Co., Ltd., Smiths Falls, Ont.  
International Harvester Co., of Can., Ltd., Hamilton, Ont.

## CUTTERS

Butterfield & Co., Inc., Rock Island, Q.

## DAIRY SUPPLIES

International Harvester Co., of Can., Ltd., Hamilton, Ont.  
R. A. Lister Co. (Canada), Ltd., Toronto  
DeLaval Dairy Supply Co., Peterboro.

## DIES

Butterfield & Co., Inc., Rock Island, Q.

## DISCS

Massey-Harris Co., Toronto.

## DITCHING MACHINES

## DRILLS

Massey-Harris Co., Toronto.

## DRILLS, TWIST

Butterfield & Co., Inc., Rock Island, Q.

## DRILLS, GRAIN

Cockshutt Plow Co., Brantford, Ont.  
International Harvester Co., of Can., Ltd., Hamilton, Ont.  
John Deere Mfg. Co., Welland, Ont.  
The Frost & Wood Co., Ltd., Smiths Falls, Ont.

## ELECTRICAL EQUIPMENT

## ENGINES

Gilson Mfg. Co., Ltd., Guelph, Ont.  
International Harvester Co., of Can., Ltd., Hamilton, Ont.  
John Deere Mfg. Co., Welland, Ont.  
The Frost & Wood Co., Ltd., Smiths Falls, Ont.  
Massey-Harris Co., Toronto.  
R. A. Lister Co. (Canada), Ltd., Toronto  
The Turner Mfg. Co., Port Washington, Wis.

## ENSILAGE CUTTERS

Gilson Mfg. Co., Guelph, Ont.  
International Harvester Co., of Can., Ltd., Hamilton, Ont.  
Massey-Harris Co., Toronto.

## FEEDERS

John Deere Mfg. Co., Welland, Ont.

## FARM MACHINERY

Cockshutt Plow Co., Brantford, Ont.  
John Deere Mfg. Co., Welland, Ont.  
International Harvester Co., of Can., Ltd., Hamilton, Ont.  
Massey-Harris Co., Toronto.  
The Frost & Wood Co., Ltd., Smiths Falls, Ont.  
R. A. Lister Co. (Canada), Ltd., Toronto  
Gilson Engine Co., Guelph, Ont.

## FEED CUTTERS

Massey-Harris Co., Toronto.  
Gilson Engine Co., Guelph, Ont.

## GREASE CUPS

## GRINDSTONES

S. Vessot & Co., Joliette, P.Q.

## GRINDERS

International Harvester Co., of Can., Ltd., Hamilton, Ont.  
Massey-Harris Co., Toronto.  
R. A. Lister Co. (Canada), Ltd., Toronto  
S. Vessot & Co., Joliette, P.Q.  
Gilson Engine Co., Guelph, Ont.

## HARROWS

Cockshutt Plow Co., Brantford, Ont.  
International Harvester Co., of Can., Ltd., Hamilton, Ont.  
John Deere Mfg. Co., Welland, Ont.  
Massey-Harris Co., Toronto.  
The Frost & Wood Co., Ltd., Smiths Falls, Ont.

## HAY LOADERS

International Harvester Co., of Can., Ltd., Hamilton, Ont.  
John Deere Mfg. Co., Welland, Ont.  
The Frost & Wood Co., Ltd., Smiths Falls, Ont.

## HARDWARE

Massey-Harris Co., Toronto.

## HAY RAKES

John Deere Mfg. Co., Welland, Ont.  
The Frost & Wood Co., Ltd., Smiths Falls, Ont.

## HAY CARRIERS

Massey-Harris Co., Toronto.

## HAY PRESSES

Birdsell Mfg. Co., Toronto.  
International Harvester Co., of Can., Ltd., Hamilton, Ont.

## HULLERS (Clover)

Birdsell Mfg. Co., Toronto.

## LIGHTNING SYSTEMS

R. A. Lister Co. (Canada), Ltd., Toronto  
Northern Electric Co., Ltd., Montreal.  
Gilson Engine Co., Guelph, Ont.

## LIME AND FERTILIZER SOWERS

John Deere Mfg. Co., Welland, Ont.

## LUBRICANTS

## MACHINE TOOLS

Windsor Machine and Tool Works, Windsor, Ont.

## MANURE CARRIERS

## MANURE SPREADERS

Cockshutt Plow Co., Brantford, Ont.  
International Harvester Co., of Can., Ltd., Hamilton, Ont.  
John Deere Mfg. Co., Welland, Ont.  
Massey-Harris Co., Toronto.  
The Frost & Wood Co., Ltd., Smiths Falls, Ont.  
Gilson Engine Co., Guelph, Ont.

## MARINE FITTINGS

Northern Electric Co., Ltd., Montreal.

## MOWERS

Cockshutt Plow Co., Brantford, Ont.  
International Harvester Co., of Can., Ltd., Hamilton, Ont.  
Massey-Harris Co., Toronto.  
The Frost & Wood Co., Ltd., Smiths Falls, Ont.

## MOTOR HORNS (Electric)

Apollo Mfg. Co., Birmingham, Eng.

## MILKING MACHINES

R. A. Lister Co. (Canada), Ltd., Toronto

## MILLING CUTTERS

Butterfield & Co., Inc., Rock Island, Q.

## OILS

## PISTON RINGS

Lamontagne Ltd., Montreal, Que.  
Wedgerite Piston Rings, Montreal, Que.

## PLOWS

Cockshutt Plow Co., Brantford, Ont.  
John Deere Mfg. Co., Welland, Ont.  
The Frost & Wood Co., Ltd., Smiths Falls, Ont.  
International Harvester Co., of Can., Ltd., Hamilton, Ont.  
Massey-Harris Co., Toronto.

## POLICE AND FIRE ALARM EQUIPMENT

Northern Electric Co., Ltd., Montreal.

## POWER AND LIGHT EQUIPMENT

Northern Electric Co., Ltd., Montreal.  
R. A. Lister Co. of Canada, Ltd., Toronto.

## POWER MACHINERY

John Deere Mfg. Co., Welland, Ont.  
Massey-Harris Co., Toronto.  
International Harvester Co., of Can., Ltd., Hamilton, Ont.  
Gilson Engine Co., Guelph, Ont.

## POWER SWITCHBOARDS

Northern Electric Co., Ltd., Montreal.

## POTATO MACHINERY

John Deere Mfg. Co., Welland, Ont.  
Cockshutt Plow Co., Brantford, Ont.

## PULVERIZERS

Cockshutt Plow Co., Brantford, Ont.  
International Harvester Co., of Can., Ltd., Hamilton, Ont.

## PULPERS

Cockshutt Plow Co., Brantford, Ont.

## RAKES

International Harvester Co., of Can., Ltd., Hamilton, Ont.  
The Frost & Wood Co., Ltd., Smiths Falls, Ont.

## REAPERS

International Harvester Co., of Can., Ltd., Hamilton, Ont.  
The Frost & Wood Co., Ltd., Smiths Falls, Ont.

## REAMERS

Butterfield & Co., Inc., Rock Island, Q.

## ROLLERS

Cockshutt Plow Co., Brantford, Ont.  
Massey-Harris Co., Toronto.

## ROLLER BEARINGS

Massey-Harris Co., Toronto.

## SAW MILL OUTFITS

Massey-Harris Co., Toronto.  
Cockshutt Plow Co., Brantford, Ont.  
International Harvester Co., of Can., Ltd., Hamilton, Ont.  
John Deere Mfg. Co., Welland, Ont.

## SCUFFLERS

Cockshutt Plow Co., Brantford, Ont.  
International Harvester Co., of Can., Ltd., Hamilton, Ont.  
John Deere Mfg. Co., Welland, Ont.

## SEEDERS

Massey-Harris Co., Toronto.

## SCALES

Can. Fairbanks-Morse Co., Montreal.

## SCREW PLATES

Butterfield & Co., Inc., Rock Island, Q.

## STABLE EQUIPMENT

Gilson Mfg. Co., Guelph, Ont.

## SLEIGHS

Cockshutt Plow Co., Brantford, Ont.  
International Harvester Co., of Can., Ltd., Hamilton, Ont.

## SILO FILLERS

Gilson Mfg. Co., Guelph, Ont.  
International Harvester Co., of Can., Ltd., Hamilton, Ont.

## SOCKET WRENCHES

R. F. Sedgley, Inc., Philadelphia, Pa.

## SEPARATORS (CREAM)

R. A. Lister Co., Toronto.

## SPREADERS, MANURE

Cockshutt Plow Co., Brantford, Ont.  
John Deere Mfg. Co., Welland, Ont.  
International Harvester Co., of Can., Ltd., Hamilton, Ont.  
Massey-Harris Co., Toronto.  
Gilson Mfg. Co., Guelph, Ont.

## SPARK PLUGS

Machine & Stamping Co., Toronto.  
Champion Spark Plug Co., Windsor, O.  
Apollo Plug Mfg. Co., Birmingham, Eng.

## SPARK PLUG CLEANERS

Champion Spark Plug Co., Windsor, O.

## TELEPHONE APPARATUS

Northern Electric Co., Ltd., Montreal.

## TRACTORS

Cleveland Tractor Co., Windsor, Ont.  
R. A. Lister Co. (Canada), Ltd., Toronto  
Essex Tractor Co., Essex, Ont.  
Gilson Mfg. Co., Guelph, Ont.  
International Harvester Co., of Can., Ltd., Hamilton, Ont.  
J. I. Case Threshing Machine Co., Inc., Racine, Wis.  
Massey-Harris Co., Toronto.  
The Turner Mfg. Co., Port Washington, Wis.

## TRACTOR PLOWS

Cockshutt Plow Co., Brantford, Ont.  
International Harvester Co., of Can., Ltd., Hamilton, Ont.  
John Deere Mfg. Co., Welland, Ont.  
Massey-Harris Co., Toronto.

## TIRES

## THRESHERS

Can. Fairbanks-Morse Co., Ltd., Montreal.  
International Harvester Co., of Can., Ltd., Hamilton, Ont.  
J. I. Case Threshing Machine Co., Inc., Racine, Wis.  
R. A. Lister Co. (Canada), Ltd., Toronto  
Gilson Mfg. Co., Guelph, Ont.

## THREAD CUTTING TAPS

Butterfield & Co., Inc., Rock Island, Q.

## TWIST DRILLS

Butterfield & Co., Inc., Rock Island, Q.

## TRUCKS

Motor Car Distributors Ltd., Montreal.  
Beaver Truck Builders, Ltd., Hamilton  
Eastern Canada Motor Truck Co., Ltd., Hull, P.Q.  
International Harvester Co., of Can., Ltd., Hamilton, Ont.

## WHEELBARROWS

Cockshutt Plow Co., Brantford, Ont.  
Massey-Harris Co., Toronto.

## WAGONS

Cockshutt Plow Co., Brantford, Ont.  
International Harvester Co., of Can., Ltd., Hamilton, Ont.  
Massey-Harris Co., Toronto.

## WATER BOWLS

Cockshutt Plow Co., Brantford, Ont.

## WIRES AND CABLES

Northern Electric Co., Ltd., Montreal



# Butterfield

*Quality*

*"The tools you buy again"*



When speaking of drills, taps, dies, reamers and milling cutters the name "Butterfield" has come to be synonymous with quality.

Among mechanics who use such tools there is a steadily growing conviction, founded on experience, that "Butterfield" tools are so carefully made that they just can't go wrong.

**Butterfield & Company, Rock Island, Quebec**

Toronto Office:

220 King Street West



# "3450" Insulators Are Practically Indestructible

They are so hard and tough that they stand up under treatment that is never experienced even in emergency use in a motor or engine.

You can heat them white hot then douse them in water—knock them with a wrench—drive them through a cake of lead—drop them on the floor, and you won't find a chip or crack in the glaze.

Do you realize what this means in ignition efficiency?



# Champion

## Dependable Spark Plugs

all have "3450" insulators. There's a type that will help to increase the efficiency of every motor car, truck, tractor, farm engine, motor boat, motor cycle or aeroplane.

Knowledge of this wonderful efficiency is a big sales help to the dealer who handles Champions. It creates business without the necessity of having to "sell" each customer.

Link up your store with our advertising and selling campaign, by displaying Champions and our dealer helps. It will put many dollars in your pocket without a great deal of effort on your part.

Keep the full line of Champions on hand, and get the full benefit of our promotion.

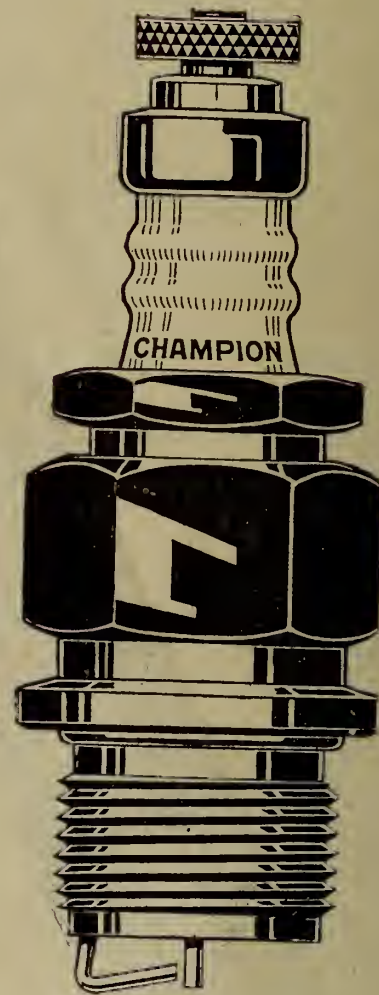

CHAMPION A 43

$\frac{7}{8}$  inch, 18 long, Price \$1.00

For use in heavy service motors, trucks, tractors and farm engines

## Champion Spark Plug Co. of Canada, Limited

Windsor, Ontario

*Largest factory in Canada making Spark Plugs exclusively and the only factory making "Champions."*





# Beaver Trucks

*"Built For Business"*

**Built in Canada's Largest  
Exclusive Truck Factory**

**UNQUESTIONABLY  
"CANADA'S LOWEST HAULING COST"**

Some open territory still available—Catalogues and further information furnished responsible dealers upon request.

**Beaver Truck Builders, Limited**  
HAMILTON, ONTARIO





# BALANCE

## *the Secret of Longer Truck Life*

Balance is responsible for the success of the new Jumbo Highway Express. It carries 4,000 pounds at 25 miles an hour with safety to the truck and load—without sacrificing any part of the long, dependable service for which Jumbo Trucks are so well known.

This Jumbo balance is the result of long, painstaking study of every part under difficult operating conditions, changing sizes and materials until each part, no matter how small, is strong enough for any emergency, yet without excessive bulk or weight.

In a truck of theoretically perfect balance, all parts should wear out at the same instant—no breakage. Here's proof that Jumbo Trucks are as near perfectly balanced as is humanly possible: many Jumbo owners with records of 20,000 to 30,000 miles have not spent a cent for repair parts. The total cost of repair parts for *all* Jumbo Trucks has averaged less than \$10 per year per truck.

Jumbo dealers are successful. Jumbo Trucks satisfy their purchasers. Satisfied customers mean steady, substantial business growth.

*Implement dealers find the Jumbo line of motor trucks a safe means of entering the truck transportation field. The unusual service Jumbo trucks give their users is a valuable asset to any dealer. Write to-day for full information on the Jumbo line, 1½ to 4 tons completely equipped, and the sales plan which has helped to put powerful sales arguments before truck buyers.*

Manufactured by  
NELSON MOTOR TRUCK COMPANY, Saginaw, Michigan, U.S.A.

*Sole Distributors in Canada*

# MOTOR CAR DISTRIBUTORS LIMITED

*27 McGill College Ave., Montreal, Que.*

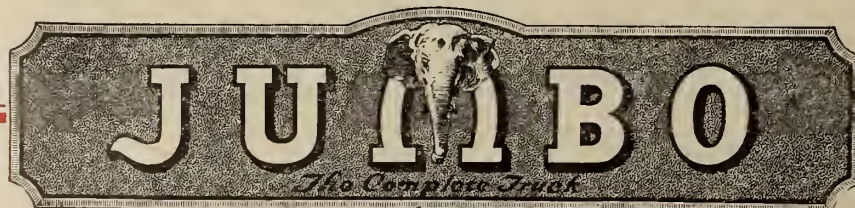



CANADIAN  
MOTOR, TRACTOR AND IMPLEMENT  
TRADE JOURNAL

Published Monthly by THE MACLEAN PUBLISHING COMPANY, LIMITED, TORONTO

MONTREAL, Southam Bldg.

WINNIPEG, 1103 Union Trust Bldg.  
NEW YORK, 1133 Broadway.

VANCOUVER, 314 Carter-Cotton Bldg., 198 Hastings St. W.  
BOSTON, 734 Old South Bldg.

CHICAGO, 405-6 Transportation Bldg.

LONDON, ENG., 88 Fleet St., E.C. 4

VOL. II, No. 10

TORONTO, OCTOBER, 1920

Subscription Price  
\$2.00 Per Year



**Raybestos**

**BRAKE  
LINING**

**B**RAKE LINING that does not WEAR well is a loss at any cost. You pay to put it on and you pay again to rip it out. For heavy duty, use Raybestos, the lining that is built for sturdy WEAR. Look for the Silver Edge.

THE CANADIAN RAYBESTOS CO.  
Peterborough Limited Ontario

*Canadian Made  
for  
Canadian Trade*



# Apollo

## BRASS SPARK PLUGS

—are sure and satisfactory sellers!

You're on a good thing when you handle APOLLO PLUGS—they represent the highest standard of British plug manufacture, are fully tested to ensure maximum efficiency and are guaranteed to give complete satisfaction.

With the APOLLO range of plugs you can promptly meet every plug request—there are models for every type of Car, Motor Truck and Tractor engine—and every plug carries a GOOD PROFIT for YOU.

Super Mica Plug is specially designed for high-speed, high-compression engines. It is unaffected by excessive heat and of exceptional durability — a plug that gives a quick start and adds power to the Engine. Retail price ..... **\$1.25**

Porcelain Plug is specially designed for the FORD engine. It has Solid Brass body, 1/2-in. gas thread, is clean to handle, will not rust, fits the special Ford spanner, is insulated with finest porcelain and is detachable for cleansing. Retail at ..... **90c**

Get on to the APOLLO PLUG proposition and you'll do big business in selling plugs. We can give prompt shipment of all models and supply you with posters, showcards and advertising literature. Write us for trade terms and full particulars of our models.

### APOLLO PLUG MFG. CO.

Canadian Head Office:

135 King St. West, Toronto. Factory: Birmingham, Eng.

Plugs for all engines

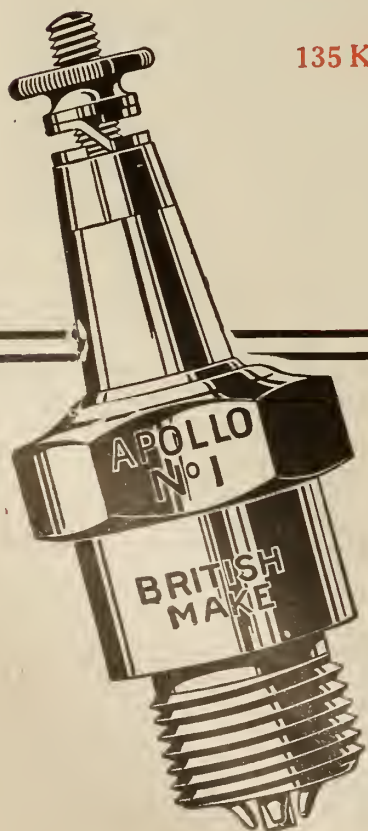

APOLLO No. 1. Super Mica Plug

APOLLO Special



Overtime Tractor Plug



APOLLO L.C.B. Special FORD Plug



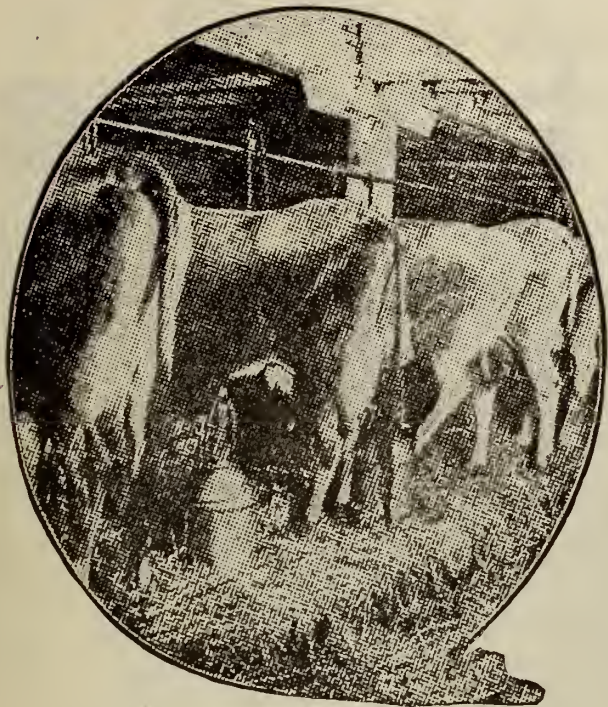

# LISTER MILKER

**T**HE man who can put "Lister" on his sign-board has a long start on his competitors.

Join up your own reputation with that enjoyed by the Lister name and you have an unbeatable selling force behind you.

*Sell the line that is already half sold—the  
"Good Old British Reliability" Lister Line*

## Sell "Good Old British Reliability"

### Some Lister Points of SUPERIORITY

- No oil or dirt gets into the milk.
- Low cost of upkeep. Parts easily renewed in case of accident.
- Easy to clean and manage.
- Easy to connect with any form of power.
- The Lister Patent Vacuum Tap makes it unnecessary even to pull off a rubber hose during the milking.
- If you need extra capacity you can add more Lister Milkers without any fuss.

We gladly furnish fullest particulars and stand behind every machine we sell. Write to-day for literature and attractive proposition to dealers.

Other Lister Lines of Reliability: The Famous Melotte Cream Separator—Lister Engine—Lister Silo Filler—Lister Grinder—Avery Tractor.

Our advertising has taught farmers everywhere to look for *reliability*, and the machine in operation never fails to make good.

The Lister is the milker of milkers, on which you can stake your reputation and make money.

The Lister is simplicity itself—any intelligent person can run it from the start with ease—fewest parts to get out of order.

**R. A. Lister & Company (Canada) Limited**

58-60 Stewart Street - Toronto



# “JOHNNY-ON- Gilson



“Goes Like Sixty”

# THE-SPOT” Engine

1<sup>3</sup>/<sub>4</sub> and 2<sup>1</sup>/<sub>4</sub> Horse Power  
“The Universal Small Engine”

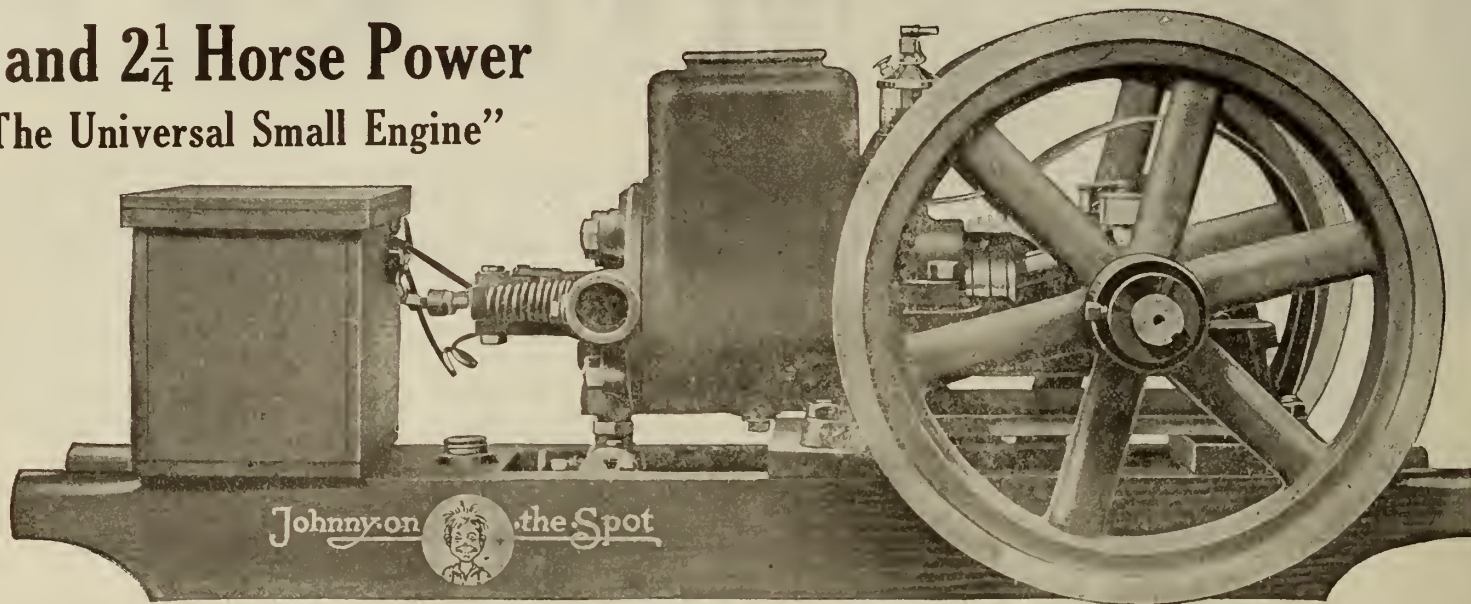

## Hello! Mr. Implement Man!

**Other Gilson  
Money-Making  
Products**

- Silo Fillers
- Silos
- Tractors
- Manure Spreaders
- Feed Grinders
- Wood Saws
- Threshers, Etc.

I know a whole lot of farmers near your town who want me to go to work for them. I'm some worker, you bet!

Now listen, you implement dealer!

The farmer who needs me will pay *you* a nice round profit if you will put me on his farm. And every time I go to work for one of your customers, his neighbors will want me or one of my larger GILSON brothers. I have made money for hundreds of dealers, and the list is growing fast.



Believe Me, Mister, this is your opportunity to make big money—don't fail to grasp it! Our wonderful, money-making proposition is ready for you. Get a piece of paper and pencil and write us! **AND DO IT NOW!**  
Please, Mister—**DO IT NOW!**

Yours for more sales,

“Johnny-on-the-Spot”

**GILSON MFG. CO.**  
LIMITED

Dept. A. Guelph, Can.

Branch Office:  
352 Elgin Ave., Winnipeg

### “Johnny-on-the-Spot”

- is the lowest priced “Quality” small engine in Canada
- has the largest sale of *Any* engine of the same size in Canada
- will bring you “repeat” orders and boost your engine sales on all sizes
- will make you the most money and the leading “Power Merchant” in your territory.

**GET OUR PROPOSITION TO-DAY**

Without any obligation on my part you may send me your agent's proposition on:—  
(Put an X opposite the product that interests you)

Silo      Engine

Silo Filler      Thresher

Manure Spreader

Tractor

Name .....  
Post Office .....  
R.R. No. .... Prov. ....  
Remarks .....

**FILL IN AND RETURN AT ONCE**

Tear OF Here



# "WATERLOO BOY"

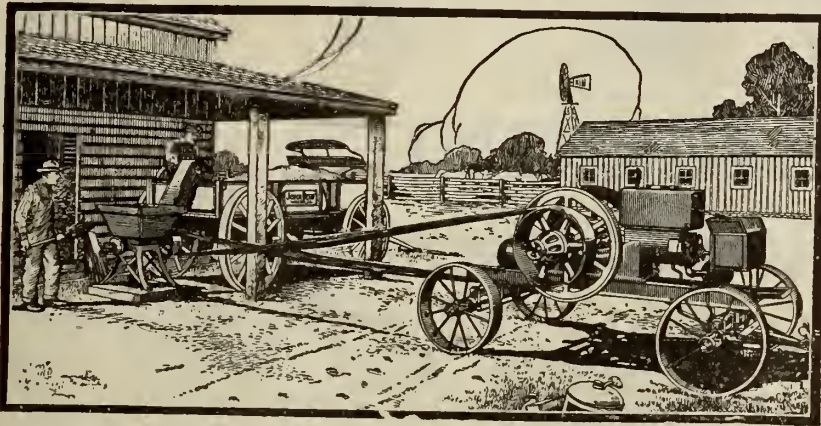

EVERY farm needs a good stationary or portable engine. Its use leads to the elimination of farm drudgery. Its use makes farm work profitable and pleasant.

### Economical to Operate

The throttle governor principle of this engine assures perfect working under any load. A steady flow of kerosene is fed to the mixer by a pump located in the mixer body. The butterfly throttle valve controls the speed of the engine by suitable connection to the governor.

### Ignition—Simple, Safe and Reliable

All "Waterloo Boy" engines are equipped with magneto and require no battery. It gives a hot spark. It is safe and reliable.

### All Parts Fit Perfectly

On the "Waterloo Boy" the machine work is accurate, which insures perfect working of all parts. The valves are ground to a perfect seat. The Crank Shaft is made from one piece of solid steel, machined and ground to perfect size and high finish. Connecting Rods are "I" beam of finest grade malleable iron, insuring strength and reliability. Piston and Piston Rings are carefully ground to size, insuring good compression.

All sizes, 2 to 25 H.P., portable and stationary.

John Deere quality and twenty-five years' experience is back of these engines.

You can depend on them.

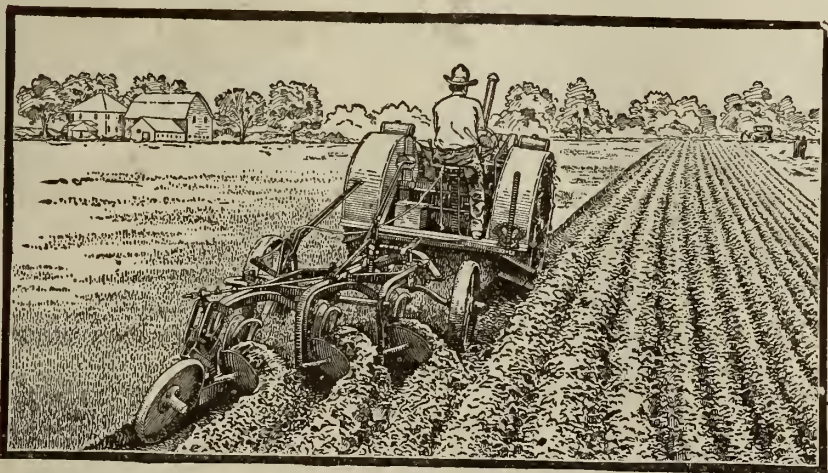

The John Deere Contract means a **profitable** business to **live** dealers in open territory. Write for literature and complete information.

## The Perfect

# KEROSENE ENGINE

**Dealers**—This is the age of power farming. Almost every farmer is a prospect for some kind of power engine, either portable or stationary. Why not take advantage of the opportunities and build up a nice business for yourselves?

John Deere lines are sold only through dealers and this business-like policy, backed up by liberal advertising co-operation and lines of superior quality, is gaining the confidence of dealers and farmers throughout Ontario.

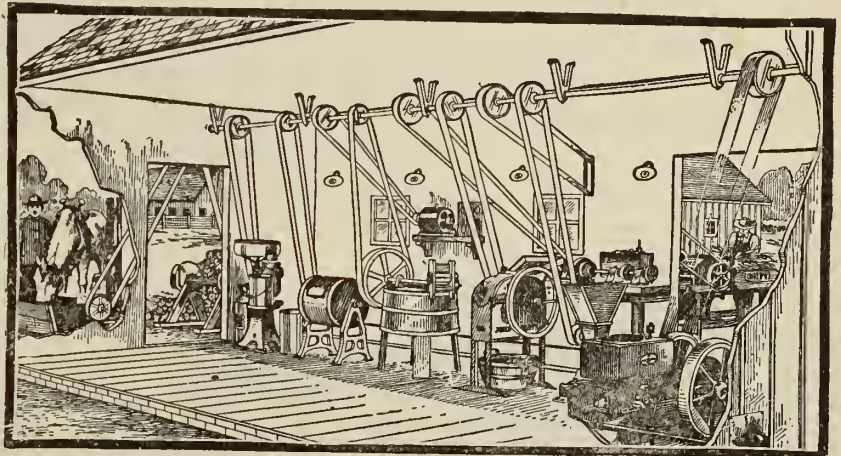

## JOHN DEERE TRACTOR PLOWS

build prestige, assure easy sales, and secure steadfast customers for John Deere dealers everywhere. The John Deere No. 5 Tractor Plow—2 or 3 bottom—is built especially to **successfully** meet **every soil condition** in the province, and will sell on its merits in direct competition with any other tractor plow on the market. The best of material and workmanship that can be obtained is used in their construction.

# THE JOHN DEERE MANUFACTURING CO., LIMITED

WELLAND

ONTARIO



# HYATT

## ROLLER BEARINGS For Ensilage Cutters

**T**HE farmer must handle his silage at the right season and have a dependable machine that will get the job done in time.

Hyatt Bearings in ensilage cutters make for more dependable operation. They require far less time for oiling, provide more economical operation, decrease the need for repairs and add greatly to the life of the machine. They never need to be adjusted.

And this is the kind of service that Hyatt Bearings also give in tractors, trucks, plows, threshing machines, grain binders, wind mills and other farm machinery.

*Send for the Ensilage Cutter Booklet.*

### HYATT ROLLER BEARING COMPANY

Tractor Bearings Division  
Chicago

Motor Bearings Division, Detroit Industrial Bearings Div., New York City

*Hyatt Roller Bearings are used in the following makes of ensilage cutters: Rowell, Holstein and Plymouth.*







# CANADIAN MOTOR, TRACTOR AND IMPLEMENT TRADE JOURNAL

Volume 2

TORONTO, OCTOBER, 1920

Number 10

## The Proper Speeds for Tractor Plowing

By L. G. HEIMPEL

WHENEVER a practical plowman gets down to hard facts and deep thought on the subject of plowing speeds, there are almost sure to be two considerations which stand head and shoulders above any others which can be brought up. The first one is the effect of speed upon the life and safety of the outfit and the second is the effect of different speeds on the quality of the work done. There are some districts in Ontario, for instance, where tractor plowing is almost certain suicide for both tractor and plows, because of the prevalence of boulders or hard heads. Again, we find land that can be plowed with tractors, but there are hard heads enough present to make fast moving perilous to the outfit; while in some districts—happy thought—there are no obstructions but long, level stretches of deep black soil to prevent a plowman from moving just as fast as he may care to go. In such cases, the speed at which we may plow the ground is governed only by the quality of the work and the power of the engine pulling the plows.

There is a great deal of misunderstanding caused by the fact that many of our 10-20 engines are sold as three-plow tractors, while other engines, also 10-20's, are rated as two-plow machines. At first sight something seems to be wrong, but when we consider that the 3-plow 10-20 moves at 2 miles per hour, while the 2-plow, 10-20, moves at three miles per hour, we find that all other things being equal, when the day is over both have done the same amount of plowing. So that after all one of the things we want to know when we consider plowing speeds and number of plows an engine will pull is how many acres will this particular outfit turn over per hour or per day, not how many plows the engine pulls.

WE must, however, go farther than this. While the number of acres turned over may be the same, what has been the effect of the day's work upon the two engines? We find that the two-plow tractor must travel three miles to every two of the three-plow machine. Now, if the life of an engine, a wheel, a gear, a drive chain, or a bearing can be measured by the number of working revolutions possible, then the two-plow high speed machine is the shorter lived machine of the two. We must not forget, however, that the three plow 10-20 is likely to be the heavier machine and that the amount of dead weight mover per mile goes quite a distance toward evening up the score piled up against the small engine on the speed question. Giving the lighter, faster engine everything we can in the way of credit the consensus of opinion among practical men seems to be that the three-plow outfit has a better chance for a long life of usefulness than the faster speeded lighter engine.

When we come to ground in which we are liable to strike an occasional boulder everyone knows that three miles an hour is a faster speed than is healthy for either plow or plowman whether drawn by horses or an engine. True, the outfit is equipped with breaking pins or automatic "unhitches," but when we have been obliged to lose good, long days waiting for a new plow beam to replace one which was bent before the pin broke, or when we have had the pleasure of digging deep into our jeans to pay for the broken points which were snapped off when a certain boulder intercepted our progress, we begin to feel sure that we were going too fast for safety

operator who plows a straight furrow is indeed a busy man.

A good connection between the furrow slice and the furrow sole or subsoil is to be much desired in a good plowing job. This is secured by a firmly packed furrow. Here we have an argument for speed. The faster the furrow turns—within certain limits—the better this connection with the subsoil. Furthermore, the faster the furrow is handled the more it is broken up, which generally speaking, is another desirable feature. Both of these requirements are, however, very well obtained by a two mile speed.

A great deal more can doubtless be said, pro or con, on this question, yet we are convinced that when the speed at which a plow is drawn exceeds a certain point, under average conditions, the engine and plow are subject to excessive strains. The quality of the work deteriorates at about the same point. What this point is in miles per hour is not very well defined, but we are pretty safe in placing it between two and two and one-half miles per hour.

THERE are a few outstanding qualities demanded by all good plowmen in a plowing job, as follows:

- (1) A well turned furrow.
- (2) A well packed furrow.
- (3) Trash well buried.
- (4) Good granulation of the furrow slice.

Because the champion plowman in a plowing match crawls along at a snail's pace when he does his best work does not mean that it is impossible to do good work at a higher speed, yet all experienced plowmen will admit that the plowman who "lets his team out," as the saying is, is not doing A1 work. The same is true with a tractor plow. As soon as the speed of the plow becomes great enough to throw the furrow from its mold-board, instead of pushing it over, the appearance of the work is impaired. When a jointer is used the slice cut by it should be laid over in the furrow in the form of a ribbon. With proper adjustment and drawn at a proper speed this is possible, but no matter how good the adjustment, once a certain speed is surpassed, the jointer slice is thrown into the furrow in lumps or heaps and the furrow slice following cannot possibly present an even surface under these conditions.

When an engine runs with one wheel in the furrow the steering of the engine is a comparatively easy matter at even a three or three and one-half mile clip, but, when an engine runs on top of the ground the

### Invents Anti-Glare Device

J. C. RYAN, a Toronto mechanic, has devised and perfected the Ryan Anti-Glare Automatic Automobile Headlight. This device has been subjected to severe tests and is said to be a revelation. It spreads the rays like a fan and is automatically controlled so that the rays, no matter at what angle the car is travelling or on what incline, the lamps adjust themselves to the road. All glare is eliminated, but there is abundance of light ahead of the car and on each side of the roadway equal to the ordinary glare lights.

The reflector is of concave form, and may be constructed in any ordinary manner. At its upper side this reflector is hinged to the upper part of the yoke by means of the trunnions, which are threaded through the ends of the yoke and provided with suitable locknuts, by means of which they may be locked as adjusted. The reflector thus swings from its upper side well above the centre of gravity. It follows from this that the reflector always tends to remain with its optical axis at a constant angle to the horizontal, despite changes in the grade over which the vehicle may be running. This prevents the beam of light from the reflector being thrown into the air when the vehicle passes over the crest of a rise, being thrown in a downward direction when the car tips after passing the crest of a rise.

As, however, the reflector would tend to oscillate, more or less under the influence of inequalities in the road. To further prevent direct rays from the reflector being directed upwards into the eyes of a driver of approaching vehicle, a segmental concave shield and reflector is provided, one edge of which is substantially coterminous with the upper part of the rim of the main reflector. The free rim of the shield is so positioned as to cut off all rays from the main reflector, which pass above the horizontal line when the vehicle is standing on level ground.

The patents for Canada, France, United States, Great Britain and Italy have been secured. The Wolseley Motors, Ltd., Toronto, have under construction the first ten sets of these lamps.

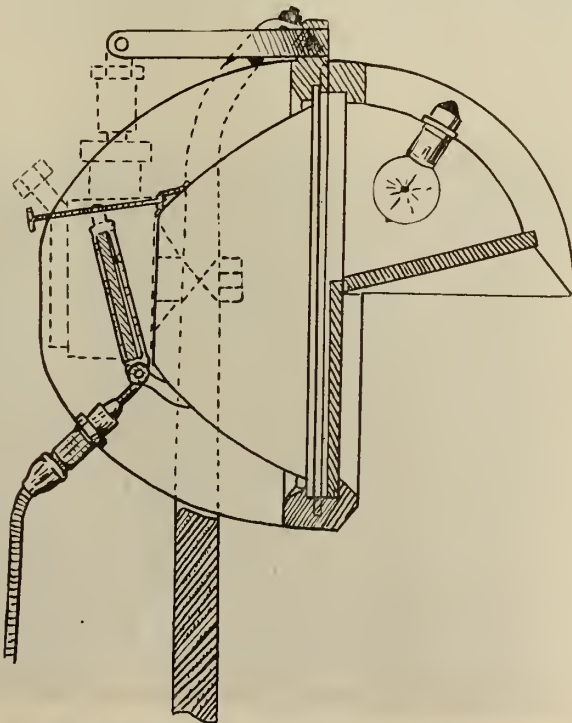

Ryan Anti-Glare Automobile Headlight.



# The Coming Tractor—What will it be Like?

THE coming tractor necessarily is one that has not yet been produced. For the purpose of this discussion I will ask that you divest your mind of all preconceived notions and attack the problem with me as an analytical one.

Some may say, "Why discuss the coming tractor? Has not the tractor already arrived?" To be sure, some things have been achieved, but the man who is satisfied with having produced a selling success and who thinks the end has been reached in design, or even in establishing a type, is either a newcomer in the industry or an optimistic inventor. On page 20 of the October 15th, 1919, issue of *Power Farming Dealer*, Mr. B. J. Walters analyzed the results of the Ohio tractor tests and drew some conclusions justified by the analysis. When it is considered that the conclusions arrived at are drawn from data of maximum performances of many tractors for the whole series of tests, it is not very comforting to have to admit the correctness of his conclusions, such as the following:

1. "The drawbar rating of a tractor, at least of the round-wheel type, is practically meaningless unless the quality of footing is definitely specified."
2. "Beyond a certain point, a high ratio of drawbar pull to tractor weight decreases rather than increases drawbar efficiency."
3. "Slippage is the greatest variable quantity in the power loss between motor and drawbar."
4. "Four-wheel tractors of typical design are likely to show decreased power and efficiency when the drawbar pull exceeds approximately 40 per cent. of the tractor weight."

That the present tractor has proved useful for plowing and allied operations must be conceded. Such machines and the problems presented in their production and sale are entirely outside the scope of this discussion. The coming tractor must displace the farm horse. The horse does not fill silos, saw wood, and thresh grain. He furnishes the tractive power to haul loads from place to place on the farm.

The coming tractor must do all the horse does—and more.

The coming tractor—what size will it be?

SEVERAL years ago when I first began studying the problem of producing a machine for the general farmer of the middle west, I made a rather extensive investigation in two states which I thought were representative, namely, Iowa and Indiana. I found on farms of 100 acres and less only one man and not to exceed four horses. On farms of 100 to 200 acres, usually one man and a boy, and not to exceed six horses. These farms were fenced and cross fenced into fields ranging usually from 20 to 40 acres. On the large farms of 500 acres and over, I would ask the owner: "How large is your largest field?" Answer: "Eighty acres." Question: "Do you leave it in eighty acre size from preference or will you some day fence it into two forties?" Answer: "It costs money to fence, but some time I'll put it in, I guess." Question: "If your farm were improved just the way you would like to have it, would you have any fields larger than forty acres?" Answer: "No." It is not necessary for me to set down in detail the reasons given which covered, among other things, crop rotation, growing of ensilage, feed and pasturing of sheep, hogs and cattle.

I offer for your consideration that the coming tractor will be the one with which one man can most effectively do all the work required on 40-acre fields. I will try to outline an ideal which any proposed design should approximate and which in my estimation will be embodied in the coming tractor.

First, it must do all the work. I have no patience with a program which would try to compromise with this problem and build different units, each one designed to do part of the tractive work on the small farm. As a manufacturing program, it is unthinkable to compound the use of metal by building specialized machines. Unless tractive machinery is built to function accurately and has a built-in permanence, it is not worth owning. The coming tractor must combine within itself a design and type which will allow all the farm work to be done with its simple,

By J. H. McCOLLOUGH, Jr.

In *The Timken*

light, high-grade, and efficient structure. It certainly is not possible to think of a program of manufacture, calling for the making of specialized machines, as anything but a temporary expedient.

The coming tractor will be an efficient unit of power which can be used for plowing, for preparing a seed bed, for cultivating, and for harvesting, so that the farmer can do his work more cheaply and satisfactorily with power equipment than he now does it with animals. The machine will be of a type or design which will be efficient on any kind of soil conditions,



The farmers' sons are intimate with the power horse.

which will suffer only slightly because of ground resistance, which will not damage the land by compression, which will be able to turn short and accurately with its load on even the softest soil, which can be easily and accurately driven by the most inexperienced and which will form a one-man outfit when hitched to any kind of useful farm machinery.

HAVING read thus far, some practical engineer is likely to say: "He is cracked on track-construction." Not necessarily. Let no one confuse the issue by considering details. If the work can be done without it, it is an end to be sought, just as it would be a distinct gain to find something cheaper and more satisfactory to displace pneumatic tires on automobiles. Years have gone by and the most that has been done is to build better quality and last service into pneumatic tires, and the world is waiting to acclaim the inventive genius who will displace the pneumatic tire.

The coming tractor will show a superior kind of efficiency. Its usable drawbar pull will not vary all the way from zero to a maximum because of adverse or favorable ground conditions. Its usable drawbar pull will fall no lower because of adverse soil and moisture conditions than two-thirds of its

working load on favorable conditions. Fuel economy will be assured by reduction to a minimum of such factors of limitation as ground resistance, differential losses, transmission losses, and even crankshaft frictional losses.

The coming tractor will have to await the building of an ideal into actual metal. The practical problems to be met in this endeavor are such as to stagger the imagination. It is a challenge to the engineers of this generation. I have confidence in the ability of the engineering profession to produce what is wanted, and if in the endeavor I can be conscious of contributing anything useful, I shall be pleased indeed.

## Ploughing Match at Hamilton

UNDER the auspices of the Ontario Plowmen's Association a plowing match and tractor and farm machinery demonstration will be held at the Hospital Farm, Hamilton, Ont., Oct. 20, 22, 1920.

On the first day tractors and all kinds of farm machinery will be in operation. Interesting demonstrations will be made with newest types of implements used by the farmers of Canada.

The second day will be devoted to plowing competition events for horse drawn implements, divided into thirteen classes.

The third day will see the tractor competitions staged. There are two classes in the tractor competition, the first is an open class and the second open only to those solely engaged in farming.

Entries for farm machinery may be made to J. Lockie Wilson, Parliament Buildings, Toronto, on or before Oct. 13. Entries for all other competitions must be made at the headquarters tent, on the grounds at the Hospital Farm before 8.30 a.m., October 21.

The officials of the Ontario and Dominion Departments of Agriculture are co-operating with the municipalities of Ontario to make this the most successful agricultural demonstration held in Canada.

The committee made arrangements for the comfort and accommodation of visitors. There will be ample room for the parking of automobiles and meals at reasonable rates will be obtainable on the grounds.

Grand Trunk, Canadian Pacific, T., H. and B., Michigan Central and also four electric lines as well as steamboat facilities make Hamilton an ideal location for the demonstration.

The committee are looking forward to a large exhibit of power farming machinery covering all the machinery and implements used on the farm. A minimum fee of \$10 for 20-ft. frontage will be charged, and 50 cents extra for each additional foot frontage required by exhibitors. Application for space should be made as early as possible to J. Lockie Wilson, Parliament Buildings, Toronto.

Dealers in power farming won't pass up this opportunity of seeing the latest in farm machinery on exhibit and in operation, and of comparing the different makes while in action.



The tractor is invading Canadian farms with a rush. This is a fall wheat field ready for the seed.



# A Tire Hospital and a Real Tire Doctor

This Firm Says "Let the Real Tire Men Give Real Service and the Hoodoo Tire Seller and Price Cutter will Soon Disappear"

"OUR customers boost us!"

So said H. A. H. Evans, of the Belleville Vulcanizing Co., of Belleville, Ontario, when asked by M. T. I. what he considered was the greatest factor in the building up of their business. Not merely was that an answer to a question asked—it is their motto!

"Our customers boost us!"

That means customers are satisfied. Which again implies that good service is given.

Good service is certainly given. If a man has trouble five miles, or ten miles out from town the Belleville Vulcanizing Co. will go to him on a minute's notice. They have placed signs at road crossings, and all likely places where motorists can see them, bearing the legend "If it's tire trouble, phone 661." If they see a customer's tires need slight repairs they advise having them done over when a dollar will do it rather than wait until the repairs will cost many dollars.

The Belleville Vulcanizing Co. was started in 1914. The proprietors are H. A. H. Evans and F. W. H. Evans. Their business was the first of its kind to be established between Montreal and Toronto; and to-day it is one of the best equipped. Each of the brothers has his side of the business to look after. H. A. H. is the vulcanizer, while his brother looks after the office and business end. They are both young men, clean cut, active and full of enthusiasm.

H. A. H. learned his trade in one of the large tire factories and after being constantly urged by the dealer through them to open up a tire hospital somewhere between Montreal and Toronto, he finally decided to start business in Belleville. His early experience is just like the experience of every other young man in a new business—lots of anxiety and very little business.

The first twenty-five cents the Belleville Vulcanizing Company took in was for repairing a puncture on a football bladder. They had about a dozen new tires in stock and at one time even that seemed too many. At the end of the first year they didn't sell over \$1,500 worth of tires, and the weekly repair business was about thirty-five dollars. The business then could only support one man. The other brother was working at something else during the day and coming in in the evenings to help in the bookkeeping. Evans Bros. are now doing over \$200 worth of repairs each week, and last year they sold \$20,000 worth of new tires.

THE business has grown up rapidly and now supports four men, all working hard every day in the week. They take turn about at night work and on Sundays.

The workshop is equipped with the latest devices in modern vulcanizing. The equipment consists of an air compressor with a capacity of 300 pounds; sectional moulds from 3 to 5½ inches; mandrils 3½ to 5 1-2 inches; 100-inch tube plate; tire spreader; buffing stand, and a 2 h.p. motor.

A special feature of the equipment, devised by H. A. H. Evans, is a clock which automatically tells when a tire is cured. It consists of an ordinary kitchen

clock with the dial insulated from the works and with holes bored or punched at each minute mark. There are a number of plugs or pins bearing numbers corresponding to the numbers on the molds. The clock is operated from dry cells. One wire is connected from the batteries to the works, one from the dial to a small bell fastened on the side of the clock, and another wire direct from the batteries to the bell. When a tire is put on a mold to be cured the plug corresponding to the number on the mold is taken and put in at a hole separated from the starting point by the number of minutes the tire is allowed to be cured. When the minute hand touches the plug at, say 45 minutes, the circuit is made between works and bell,

However, so far, they have not been called upon to make good their guarantee.

"In the vulcanizing business," said Mr. H. Evans, "service is the only thing that counts. Service is very important in all branches of the automobile industry but in vulcanizing it is most important of all. A vulcanizer cannot do faulty work and get away with it for long.

"Not only must the tire man do sound repairing but he must also do some sound advising. I mean by that it is necessary for him to advise his customers whether a tire needs repairing, and whether it is worth repairing. We never attempt to repair a tire if it is, in our judgment, ready for the scrap heap.

"At first when we adopted this policy some of our customers were inclined to demur and even insist that we make a repair. I am glad to say now they invariably abide by our decision. A man one day brought in three tires and after examining them I advised him to scrap them as they were beyond repair, but he thought they were worth it and insisted that I go ahead with the repairing. I repaired them on his responsibility but after they were in use a short time they played out. He came in to me afterwards and said he should have relied on my judgment. Now whatever I advise he relies on it and is one of our best friends.

"Our policy is so well known now we have no trouble; whatever we say goes.

"In the sale of new tires we also do our best to advise our customers.

"Some years, for no known reason, one make of tires will fall away from their usual high standard. This happens to the best of tires, and the reason for this falling off, as I said, is a mystery. In a case like this I advise my customers what to buy. Last summer a local fruit dealer came into our store and wanted to purchase two tires. We had six different makes for him to choose from. He asked for a certain make and as it happened to be the one off color that season I advised him to purchase another tire. He said he had always had good satisfaction from the tire he wanted and thought he would prefer to buy it again. He bought that tire and lived to regret it. He is content now to take our advice.

"For every dollar we take from a man we give him a dollar's worth of service and we are proud to say we have not lost a customer in our history.

"We pay particular attention to our lady customers. We never allow a woman to inflate the tires on her car no do anything else that is likely to cause her work or soil her hands or dress. We make it our business to be on the spot when ladies come around.

"We get publicity by sending out circular letters, monthly calendars, and placing signs at all road crossings and other places where motorists are likely to see them. We find by this policy of advertising we reach our real customers. We also keep in close touch with the different garages where vulcanizing is not done and find we get a large percentage of our work that way.

"During the winter months when there are not

(Continued on page 35.)



This picture shows Evans Bros. believe in signs

the bell rings and the tire is ready to come off the mold. Several tires can be on the molds at once and each will ring off at its own time. With this system the men are free to do some other work without worrying about the curing. The bell rings louder than a telephone bell and can be heard all over the workshop.

THERE is a room lined with asbestos and equipped with an electric heater for speeding up the drying out of damp tires. Tires taken off a car in wet and muddy weather are put in this room overnight and are in condition to be repaired in the morning. The new-tire room is fitted up with racks on which are stored about \$10,000 worth of tires of all sizes—cord and fabric.

Tires are not kept from one year to another by the Belleville Vulcanizing Company. Their stock is so arranged that one year's supply is sold the same year and a new stock brought in, usually in the spring. Thus the danger of depreciation in tires stocked for sale is brought to the minimum, and customers are assured of tires of maximum virility.

Evans Bros. back up every tire they sell by their own personal guarantee. That does not mean, of course, that Evans Bros. have to come good for tires that fail to measure up under favorable usage—for all tire manufacturers guarantee their product and are willing to compensate customers whose tires break down through faulty material or workmanship—but it does mean that should the manufacturer fail to make the adjustment Evans Bros. will not fail.



# Belting Requirements for Farm Machinery

**P**RACTICALLY every tractor and gasoline engine sold means the sale of a belt to be used in driving the machinery which the engine was bought to operate. Very often a number of belts will be required to drive different machines, especially where a stationary engine is to drive a line shaft connected to several machines. The sale of belting, therefore, should be a profitable line for the implement dealer.

More or less trouble is experienced by farmers in selecting and using the belts they require for use in

By **ARNOLD P. YERKES**

will have no occasion to handle any leather belting excepting the single-ply. They may have occasional customers who have had experience in machine shops or have been informed by some mechanic that a two-ply leather belt is much superior to the single-ply, as for some kinds of shops' use this is the case. A double-ply belt cannot be used satisfactorily on pulleys less than about a foot in diameter and therefore

ilar work where the double-ply belting may be desirable, but such exceptions will be rare.

Thick canvas or rubber belts will stand up better than double-ply leather belts when run over small pulleys, but it is never advisable to use too thick a belt. Strength should be obtained by width rather than thickness where practicable. Using an unnecessarily thick belt wastes power because it takes more power to bend it as it passes around the pulleys. Furthermore, the thick belt tends to destroy itself, as the plies which are on the outside, as the belt passes over a pulley, are badly stretched, while those on the inside are crushed together.

For this reason it is not usually advisable to use a belt heavier than 4-ply. This thickness is the one in most common use and is quite satisfactory under most conditions.

Of course the canvas and rubber belts do not always have the same thickness of material—some makes will be heavier than others—but 4-ply belts of any good standard make will usually be as thick as should be used, although some threshermen prefer 5 or 6-ply.

Some makes of cotton belts are woven in one piece, and not made of separate layers. These are generally sold as 4-ply, 5-ply, etc., for purpose of comparison, the "4-ply" being about the same thickness as a 4-ply belt made of 4 separate layers.

The width of belt which should be used in a given case depends upon the amount of power transmitted and the speed at which the belt is run. For instance, a belt four inches wide will transmit 12 horse power at a speed of 3,000 feet per minute and be within its safe capacity. However, if the same amount of power was transmitted at a belt speed of only 1,500 feet per minute the pull on the belt would necessarily be twice as great and an eight-inch belt should therefore be used. Or if 24 horsepower is to be transmitted with a belt speed of 3,000 feet, the pull would necessarily be twice as great as when only 12 horsepower is being transmitted at the same speed, therefore, twice as wide a belt should be used, that is, one 8-inches wide.

**O**NLY one formula need be kept in mind to figure the horsepower which a belt will transmit, viz., velocity in feet per minute times width of belt in inches divided by 1,000 equals the normal horsepower which a single-ply leather belt should transmit with a tension of thirty-three pounds per inch of width,

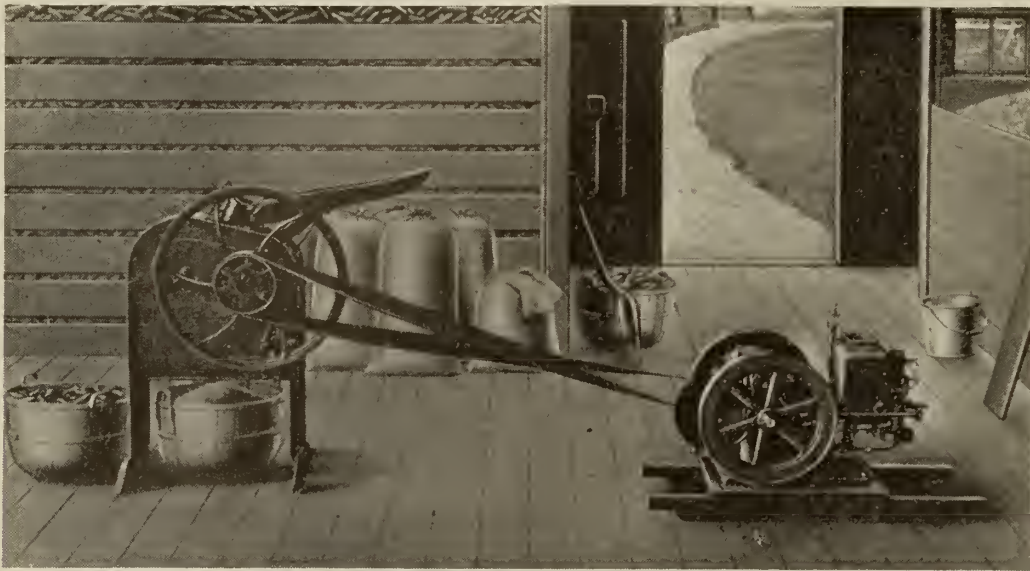

Corn sheller operated from small gasoline engine.

connection with their tractors and stationary engines. A great many farmers have little or no idea of just what kind of belt, or what size, they need for a given purpose. They often have trouble in determining the proper length of belts. Then there are many cases where an engine with a fixed speed is to be used with some machine on which the pulley is not the right diameter to give the proper speed with the normal belt speed of the engine.

Since a great many farmers are entirely at a loss in the matter of choosing, putting into use and caring for the belts required for farm machines, the implement dealer often has an opportunity to render to his customers some service along this line which may be of great value to them, and which costs the dealer nothing but the time required to obtain the necessary information. If he does not care to go to the trouble of memorizing the necessary data and information, he should at least keep handy for reference, when needed, the information regarding the proper width and thickness of belts for machines commonly found on farms in his neighborhood and for which farmers are likely to need belts, the formulas for computing belt speeds, speeds of pulleys, etc. A little advice at the time the belt is purchased, so as to insure getting one which will give satisfaction, may avoid a great deal of trouble for the purchaser and more or less ill feeling on his part toward the dealer who sold him a belt which was unsuited for the work for which it was intended.

Large leather belts for driving separators, etc., are seldom called for to-day, but there are still a few in use and when men who have been accustomed to using leather belts, either on the farm or in shops, wish to buy a canvas or rubber belt they are quite likely to inquire regarding the relative strengths of the different materials. Canvas and rubber belts come in different thicknesses, being made up of various layers or "plies." A 4-ply canvas or rubber belt is usually considered the equivalent of a single-ply leather belt, inch for inch of width. Therefore, if a rubber or canvas belt is required to replace a single-ply leather belt six inches wide a 4-ply of the same width will be the proper thing to use.

Double-ply leather belting is not very often used on farm machines, and most implement dealers

this kind of belting has little place on farm machines. In case a customer inquires for double-ply leather belting, therefore, he should be informed that this will not work satisfactory on small pulleys, and unless the belt is to be used during a large part of the year the double-ply belting will not pay on farm machines. There may be some few exceptions to this rule where a large pump is to be operated for several months for irrigation purposes or some sim-



This shows effects of running belt twisted over pulleys out of line. One edge badly stretched so that the belt does not hang flat.



which is approximately the tension under which a belt will work without slipping under ordinary conditions.

By keeping in mind the fact that four plies of rubber or canvas belting are equal to one single ply leather belt this formula can be used for any thickness of rubber or canvas belting. For example, a six-ply rubber or canvas belting of given width would transmit fifty per cent. more horsepower than the figure obtained by the above formula for a belt of the same width and which is based on a 4-ply belt.

It is not very often that a dealer needs to figure the length of belt required between two pulleys or fixed shafts. Such measurements are usually required only for the small belts on separators or between a line shaft in farm power and some stationary machines. In most such cases the farmer will measure the length of belt required by passing a cord or rope around the pulleys and measuring the rope. However, in case a farmer asks for a belt long enough to go around two pulleys of given diameter on shafts a certain distance apart, the length can be computed by the rule used by engineers as follows:

Add together the diameters of the two pulleys, divide the sum by two, multiply the quotient by 3 1-4 and add the product to twice the distance between the centres of the shafts.

In buying belts for farm machines the natural tendency of the inexperienced farmer is to buy one as short as it will be practicable to use in order to keep down the cost as much as possible. Farmers who have had experience with belt-driven machines, however, will realize that considerable length of belt is necessary in driving most machines, as the weight of the belt on the pulleys gives the required friction to drive the outfit. With a short belt the friction is less and slippage will occur. At the same time it should be kept in mind that the less power to be transmitted the less friction will be required, and a shorter belt can therefore be used safely.

SOMETIMES the mistake is made of purchasing for a small separator which is to be operated by a small tractor a belt just as long as will be used with a powerful engine and large separator. In some cases the belts purchased have been so long and heavy that a small tractor did not even have power enough to raise them from the ground. Such a belt not only costs more than is necessary but is unsatisfactory in operation with such an outfit. It also places a great deal of unnecessary pressure and wear on the bearings of the shafts on which the pulleys are mounted. The belt should be only long enough and heavy enough to prevent slippage.

It does not necessarily follow, however, that because a long heavy belt grips the pulley tighter, and will pull more without slippage than will a shorter or lighter one, that all slippage troubles are due to too short a belt or one which is too light. The condition of the contact surface of the belt has a great deal to do with belt slippage.

Even a heavy leather belt will slip badly if it is allowed to become dry or hard. In this condition it cannot hug the surface of the belt pulley close enough to create the necessary friction. Leather belts should be kept soft and pliable to work satisfactorily. To keep them this way will require an occasional dressing of neatsfoot oil or some good belt dressing. Most good belt dressings, however, are composed largely of neatsfoot oil. The not uncommon practice of using ordinary rosin, tar or other sticky substance to prevent slippage of leather belts is not to be recommended. Such substances may afford temporary relief, but they tend to build up a hard, slippery surface on the belt which will give more trouble later on. Leather belts should be run with the hair side next to the pulley, and if kept soft and pliable as above mentioned, applications of rosin or similar substances will be unnecessary, provided the belt is of the proper width and the pulleys not too small. In the latter case lagging the pulley on which the belt is slipping will often offer relief; if it will not, a larger pulley is probably the best solution.

Changing the size of either the driver or driven pulley without making a corresponding change in the other will of course change the speed at which the machine will be run. This may sometimes be offset by setting the governor of the engine so as to run at the proper speed to compensate for the change, or by changing the size of both pulleys.

Most machines must be run steadily at some particular speed in order to do their best work. This is particularly true of threshers, and here again is where the dealer should be well posted in order to

help his customers to get the right combination of pulleys to obtain the proper speed. The proper speed of most machines is printed on them, or given in the catalog. The belt speed of most tractors and engines is also given in the literature. But many farmers do not know just how to tell from these figures whether their engine will drive the machine at the proper speed.

It is simple enough, upon a moment's reflection. It is obvious that a belt running at say 3,000 feet

per minute is the number of times the pulley will turn over per minute. Sometimes it will be easier to figure it out in inches, ignoring small fractions, as the result will be close enough. The circumference of a pulley is equal to 3 1-7 times its diameter, and by figuring this in whole numbers, ignoring fractions of an inch and dividing it into the speed of the belt in feet per minute times twelve, the result will be the required figure.

Then, supposing the pulley is not the right size to give the proper speed and it is desired to ascertain what size of pulley will answer, simply divide the number of revolutions the pulley should make into the number of feet per minute the belt is travelling—this will give the circumference necessary to produce the proper speed, and, then, to find the proper diameter, divide by 3 1-7. For example: Suppose a tractor gives a belt speed of 2,600 feet per minute and it is wanted to drive a separator which should run at 1,200 r.p.m. Twelve hundred goes into 2,600 2 1-6 times, so the pulley would have to be 2 1-6 feet around to give the right speed. Two and one-sixth feet equal twenty-six inches, which, divided by 3 1-7, equals 8 1-3, approximately. The pulley therefore should be about 8 1-3 inches in diameter.

Other problems which are likely to come up can be worked out similarly with just a little reasoning. It does not require an engineer, but merely the exercise of a little reasoning and common sense.

A GREAT deal of trouble with belts on farm machines is due to abuse. In the case of leather belts, they are frequently allowed to become so dry and hard that they slip badly or crack and break. Canvas and rubber belts are often stored in places where they become more or less damaged by weather and exposure.

One of the most common ways in which belts are abused is by running them over pulleys which are not in proper alignment. This practice, especially when the belt is twisted, will stretch one side of the belt more than the other—thus throwing a greater strain on one side of the belt than on the other, tending to cause belt slippage because the belt does not hug the pulley evenly across its entire width.

Belts are often run out of line in this way when the operators think they are in proper position. Some men have the idea that so long as the driving belt runs in the centre of both pulleys, the pulleys must be in alignment. A long drive belt, such as is used on threshers, can be run a foot or two out of alignment, and yet have it run on the centre of the driving pulley on the tractor, or even toward the side of the pulley farthest out of line (as most threshers are equipped with a belt guide, the belt cannot run off the pulley on the cylinder shaft).

The reason for this is that if the tractor does not stand square with the thresher, the drive pulley will present a slight angle to the line in which the belt should run and the belt will tend to run to one side of the drive pulley.

One of the accompanying cuts shows a tractor drive pulley which is about eighteen inches to the left of its proper position. The tractor, however, is turned slightly to the right, and the drive belt, instead of running off the pulley to the right, as might be expected from the fact that the tractor is too far to the left, really runs toward the left hand side of the pulley as shown in the cut. The picture shows the belt in the actual position in which it was running. The white line is made by a cord which was placed in the position in which the belt should have been run.

It is not uncommon to see operators place a tractor to operate a thresher, and after trying the belt and finding that it runs to one side or the other move the tractor toward the side to which the belt ran, when all that was really needed was to set the tractor square with the thresher.

It is a rather common practice for threshermen to set tractors out of line when a cross wind is interfering with the belt. Quite often setting the tractor at a slight angle, but with the belt pulley in practically the same position as before, will accomplish the same result, that is, keeping the belt from being run off by the wind. Whenever possible, however, the outfit should be placed so as to have the wind blowing lengthwise with the belt, as it will then not interfere to any great extent. Where this is impossible and the belt cannot be kept on the pulley a guide in the form of a smooth piece of wide metal pipe, etc., can be used to keep the belt from running off.



Tractor placed nearly 18 inches out of line, but front end turned to right as in No. 4 of diagram—to show that because belt runs to left, the tractor is not necessarily too far to right.

per minute will turn a pulley as many times per minute as the circumference of the pulley is contained in 3,000—that is, if a belt running at 3,000 feet per minute passes around a pulley which is two feet around (about 7 1/2 inches in diameter) it will turn the pulley 1,500 times every minute, because it will require two feet of belt to make the pulley turn around once.

Any belt speed and any diameter of pulley can be worked out the same way—simply by finding how many feet or inches of belt are required to turn the pulley once and dividing this into the number of feet of belt passing over the pulley each minute; the re-

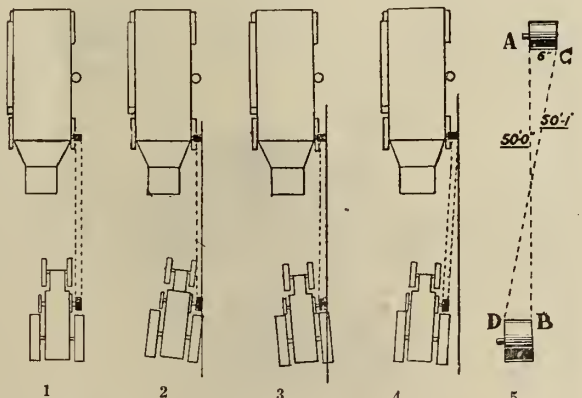

1. Shows how tractor should be placed—belt pulleys in perfect alignment.
2. Pulleys almost in alignment, but tractor not standing square—belt will run to inside of drive pulley.
3. Front of tractor toward left—belt will run off drive pulley.
4. Tractor too far to left, but front turned to right—belt may run in centre, to right, or to left, depending upon angle of tractor—see above cuts.
5. Shows how one side of twisted belt must stretch when tractor is 6" out of line. Straight line measures 50 feet—diagonal line 50 feet 1 inch. This practice causes belt trouble.



# Banking Credit for Power Farming Dealers

The Progress of any Farming Community To-day Depends to a Very Large Extent on Power Farming and How it is Handled. The Success or Failure Depends a Good Deal on the Support it Gets from the Banker

THE part played in the life of the community to-day by the dealer in power farming and automotive goods is no inconsiderable one, and with the present day rapid advent of the tractor and truck on the farm is receiving acknowledgment as one of the leading factors in successful agricultural community development.

High wages and scarcity of farm labor force the farmer to curtail his production or invest in labor-saving machinery. Given the opportunity, he will do the latter, for few farmers feel that they can curtail their operations to any great extent under the present economic situation.

It is a fact that to-day but an exceedingly small fraction of the farms in this country are taking advantage of the labor-saving, production-increasing machines that are on the market, and as a result the whole world suffers—the farmer because his operating costs are so high as to eat up a large share of his income, and the consumer because food production is low and prices are high.

Another influence of modern power farming machinery—and a vitally important one—is the stemming of the city-ward tide of farm boys. Give the average farm youth a complete outfit of up-to-date equipment, including a tractor for his field work and a truck for his road work and the farm becomes a far more interesting place and with a much stronger appeal than the city could ever hold out.

May not the solution of the present problem of unrest be a matter of less talk and more work—a clearing out of the congested centres of population—a bringing of people from cities to soil and a reversion of the flood to the big towns from the farm which has been characteristic of the past generation?

IF it is to prove popular with the coming generation, however, agricultural production must be dignified with administrative effort in true keeping with its position—modern methods must be applied to farming as they are to other forms of industry.

It is a well known fact that the business men of the town mold the habits of the farmers tributary to their particular community, hence the opportunity for the power farming dealer and his banker to increase farm production, reduce costs and in general raise the standard of operation on the farms in their community.

Bankers as a whole are to-day thoroughly alive to the advantages of power equipment on the farm and show themselves willing to cooperate in extending the power farming dealer's program.

The dealer has two financing problems to cope with. First, he must take care of his wholesale shipments and then he must finance his retail sales.

Most dealers require accommodation of some sort in handling wholesale shipments of tractors, trucks, automobiles, etc., in carload lots—the only economical way to handle these goods on account of the saving in freight.

Accommodation with respect to wholesale shipments is to-day being generally accorded by bankers, warehouse receipts or trust receipts covering the goods shipped being held as collateral, proceeds of retail sales being applied as made to reduce the obligation given for wholesale shipments.

DOUBT in the minds of bankers as to security value and marketability of automotive and power farming goods manufactured by concerns of good standing has been dispersed by the satisfactory manner in which obligations covering these goods are generally handled. While the amount of the accommodation usually required is fairly large, still at the same time the goods turn quickly, and a wide-awake dealer need never be burdened with dead stock on his hands.

Commercial discount companies located in large financial centres make a business of financing wholesale automotive and power farming shipments on a

By J. McCULLOUGH

large scale, but since the dealer must necessarily work at long range with these concerns, it is not nearly so satisfactory as working with a local bank.

Assuming that the dealer has been satisfactorily taken care of on his wholesale requirements, let us consider the proposition from a retail standpoint. A good customer comes in to buy a tractor, a tractor plow and a disc, the entire sale amounts to something over two thousand dollars. This customer owns 240 acres of good land, clear of encumbrance, and bears a good record in the community. However, he can pay only five hundred dollars in cash on his purchase at present, and wishes time on the balance until fall.

The purchase of the tractor will enable the farmer to sell some of his horses that have been standing in the barn all winter eating their heads off, and will enable him to get along without that hired man that has been loafing around the farm to the tune of seventy dollars a month and board. With the tractor's increased capacity for work the farmer can rent a neighboring quarter section and put it into crop.

It is obvious that the dealer, having paid cash for his tractor wholesale, must have his settlement with his customer on a basis that will enable him to get his cash from the transaction.

Here is a proposition that is just as much a necessity to successful farming as a good barn, and the banker who finances the tractor sale gives his customer a lift toward the goal of financial independence, and helps him put his farm on a basis approximating the modern science of management.

The tractor, truck, automobile or other power farming implement is of itself good security and lends itself as an additional factor of safety collateral to the loan.

THE automotive industries just at this time are playing a very important part in cementing together in a bond of common relationship the farm and town.

When it is known that 38 per cent. of the entire gross volume of business out of Minneapolis and St. Paul for the year 1919 was automotive (tractors, trucks, automobiles, power implements, accessories, etc.) one realizes the extent to which this business has grown.

Production and transportation—the two big problems faced by every farmer—are bound up with tractor, truck, automobile and power farming implements.

The progress of any farming community to-day depends to a very great extent on the manner in which the automotive business is handled—and the success or failure of the local automotive and power farming dealer depends a good deal on what kind of co-operation he gets from his banker.

The writer of this article, now a dealer of the type above described, and formerly a banker, has given the matter close observation, and it is his opinion, that while there are still a few bankers that are skeptical as to the outcome of power farming, the large majority of bankers are enthusiastically behind the movement, like the bankers of the country always are whenever anything worth while comes to their attention requesting support. For the banker knows that anything that tends toward the success of the farmer and the community in general means success for himself and his bank.

## Must Have Farmers' Confidence

BEING a successful merchant does not consist in only carrying a stock of goods, pricing them right and advertising, for after all these things the outstanding important thing is for the merchant to have the confidence of the buying public.

The retail implement merchant has a real job confronting him to establish the confidence in the farmer's mind that he is the proper and economical source of distribution for all the farmer's needs.

The amount of misrepresentation that has been going the rounds about the average implement dealer should have worked out to wake the dealer up to his duty in this connection, for ever since the war conditions came on us and other interests who were before engaged in other lines, but who entered the implement field, there has been a steady effort to discredit the implement merchants and this has had its effect on the farmer.

Papers calculated to serve the farmer have by various methods tried to show the farmer that the source of his buying service was wrong, for these papers were quick to see in the unrest of the farmer a chance to curry his favor and get his subscription that could be used on the manufacturer to secure expensive advertising.

That the various methods employed have had the effect on the farmer to make him distrustful is plain to any dealer, and so we say that the important thing for the retail merchant to do is to fight against this and to show the farmer that his business is after all so organized as to help him and to do that at the smallest possible cost.

With the growing tendency to disturb the farmer and talk to him about new methods of buying, it is high time that the merchants of every community got together and by concerted action headed off the lie and supplanted it with the truth.

The mail order house is active and soon we shall show pictures of new buildings here in the East that will appeal to some, but surely to all make plain that this form of competition is real and must be met.

With the proper community understanding and team work no mail order house could live and do business, and the fault of it all lies in the apathy of the retail merchant.

The towns in the East who have active Chambers of Commerce, organizations, or some other form that will do the same work, are very few, and yet the ones who have this can show wonderful results following an educational campaign to show the home folks that their community is the best on earth and that the people of that community ought to look on many things with the same eyes and with the same purpose.

Our advice is for you to start something in your section. Talk it over with every man, the preacher, the banker, the school teacher, and every merchant and manufacturer, and you will find a lot of these people thinking as you do, but just waiting for some leader to show the way.—*Eastern Dealer.*

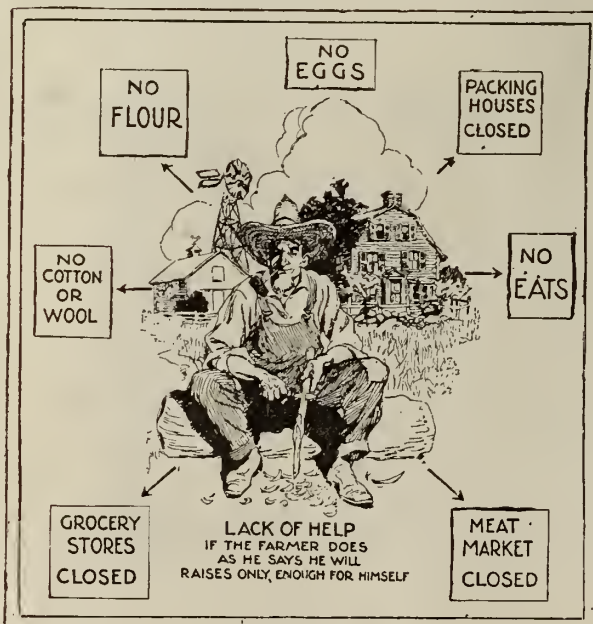

SUPPOSE HE DID!



# Increased Railway Rates Boost Truck Sales

By DONALD R. COWAN

In recent years the increases in the cost of cartage at railway terminals have ranged from sixty to one hundred per cent. In some cases the terminal charges are actually greater than the railway rates on short haul shipments of freight, especially in less than car lots. When cartage rates and local freight rates are both making rapid advances the most cautious observer cannot avoid drawing the conclusion that there is no ground for pessimism regarding the future of motor transportation.

THERE is another consideration of decided importance. Freight of high value per unit of weight and bulk has always been more profitable for the motor truck to haul than freight of the opposite character because it will bear a high rate. Especially is this true of perishable goods. Up to the present motor truck operators have preferred to leave all bulky commodities of low value for the railways to carry because these commodities were not paying freight. Besides, business men shipping this kind of freight have not employed motor trucks because

fruit on the market or allowing it to go to waste. Furthermore, there is good reason to believe that motor trucks give better distribution and haul the fruit at a lower rate than the railways. The truck may make delivery to the consumer's door and that is the link in the marketing of commodities which cannot be fulfilled by the railway. Also, the point that the hauling of fruit by rail is cheaper than by truck may be disputed. A case which came under the personal observation of the writer during an investigation of the marketing of fruit by truck, may be cited in support of the contention that the truck may haul fruit cheaper than the railway.

ON September 15th, 1919, the owner of a fruit store in Cobourg began a journey by truck to Toronto at 2 a.m. He was accompanied by a helper and arrived at 10 a.m. after covering a distance of 72 miles. The load consisted of 116 eleven quart baskets of tomatoes, 1½ tons in weight, and it was sold at the fruit market. The return load purchased at the fruit market consisted of as many baskets of peaches and grapes. The express charges on the fruit hauled would have been \$45.00. This enterprising Cobourg business man estimated the cost of his journey as follows:—

12 gal. gasoline	at 38c. ....	\$4.56
4 quarts oil at	25c. ....	1.00
2 men's wages.		8.00
Depreciation on truck	.....	4.00
		<hr/>
		\$17.56

Placing the total cost of his trip at \$20.00, he effected a saving of \$25.00.

Moreover, by the use of the truck, the cost and inconvenience of hauling the tomatoes to the train and loading them, and the unloading of the peaches and hauling them to the store, were eliminated. A further saving was accomplished by selling and buying on the fruit market in person. It was estimated that the tomatoes were sold at 10 cents per basket above the price obtainable when shipped by train and that the grapes and peaches were purchased at

from 10 to 15 cents less than the prevailing prices. It was possible also to inspect the fruit before purchasing. Fruit in poor condition is frequently shipped to purchasers, and when complaint is made, the blame is wrongly placed upon the express company. In the experience of this trip is illustrated the possibility of decreasing the cost of marketing and of selling to the consumer fruit in better condition at a lower price.

IF the express rates are raised to correspond with the new schedule of railway freight rates, as has been already intimated by those interested, economy of using motor trucks in marketing fruit as well as other commodities will become even more apparent.

The recent boost in railway rates will cause many large urban and rural shippers who were formerly indifferent spectators to take a decided interest in the motor truck because its use will likely point the way to an actual saving of many dollars in shipping costs. They are more likely than in the past to call for advice and actual cost figures from the distributor and salesman of motor trucks. There is no real ground for pessimism in the motor truck industry. It is true that the demand for motor vehicles is slack at the present time, but are not all phases of industry experiencing, or about to experience, a depression?



NCE again the railway companies of this country have succeeded in obtaining an increase in their revenue amounting to many millions of dollars. This increase was approved by the Board of Railway Commissioners and went into effect on September 13th, 1920. By it, railway rates were given a boost of 35 per cent. in Western Canada and 40 per cent. in Eastern Canada. Coming at a time when all classes of business are face to face with a slackening of demand, restriction of credit,

and lowering of prices, the new railway rates are an additional embarrassment to business men and a heavy burden upon the consuming public.

The railways should not expect to carry the same volume of traffic as they carried before the new schedule of rates came into effect. It is a fundamental economic law that a rise in the cost of goods or services will tend to bring about a slackening of demand. The agencies of transportation render an extremely important service to humanity by carrying the goods which the factories, the farms, and the general public require. If the cost of the service rendered by the railways is increased, those persons who, under competitive conditions, were hardly able to bear the old railway rates will either be forced out of business or will have to employ cheaper agencies of transportation to satisfy their wants.

For extensive overland haulings between local points the logical alternative is the motor truck. During the past two years enterprising truck operators have demonstrated that in many cases where the roads are fairly good, they could haul more cheaply than the railways between the manufacturing centres and the intensive farming districts of Southern Ontario. Their rates for trucking were seldom higher, and in most cases they were lower than the railway rates, especially if there be added to the latter the cost of cartage at the terminals.

As local railway rates are almost always higher than through rates the proportionate increase approved by the railway commissioners will bring about a greater gross increase in the former than in the latter, and the burden will fall upon the small cities, towns, and country villages. As the motor truck usually has the advantage over the railway in short hauls, the tremendous increase in local railway freight rates will widen the scope, lengthen the haul, and increase the use of the motor truck in sections of Canada, especially in Ontario, where the distances between the cities, the towns, and the rich agricultural districts are not very great.

It is commonly known that one of the important economies to be accomplished by the use of the motor truck is the direct shipment of goods from consignor to consignee. It eliminates the cartage of freight to and from the railway terminals, the cost of which should be added to actual railway charges when a comparison with motor transportation rates is made.

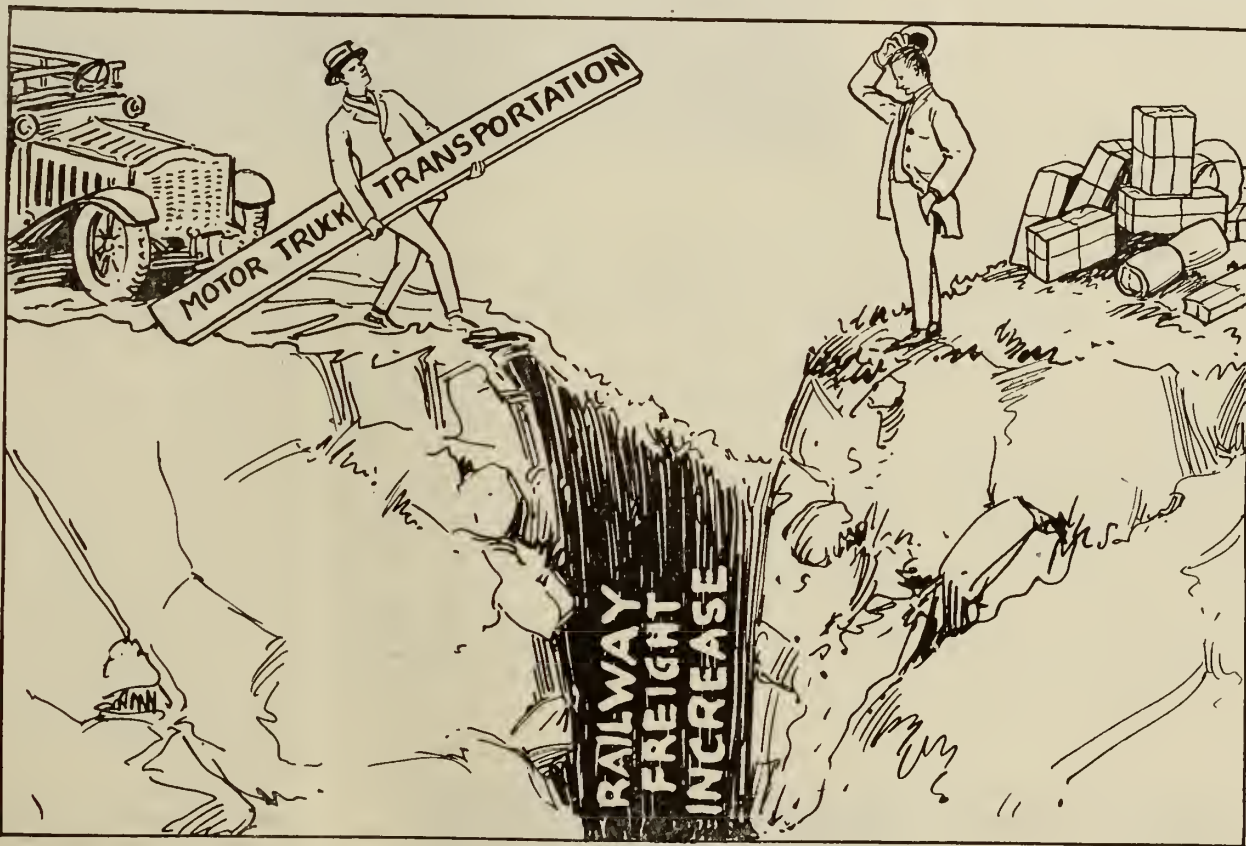

Bridging the gap

the railway rates were cheaper. In a great many instances the advance in railway rates will make it fairly profitable to haul bulky freight by motor truck, and the railways will lose a large volume of local traffic of this character to the more efficient highway transportation companies. As a consequence the avenue will be opened up for the sale of the more expensive trucks, especially those equipped with extra large bodies.

Under the present circumstances the wide awake truck distributor will not allow the present opportunity of selling trucks to fruit growers to pass by without making at least a thorough canvass of the situation. This year the fruit growers in the Niagara Peninsula have a record harvest, but the fruit is going to waste because the proper baskets and crates are not available and the railway companies are unable to carry the fruit except in regulation containers. Consequently the fruit growers are losing thousands of dollars, and the consuming public are unable to buy the fruit at the very low prices which would be brought about by the rapid and efficient shipment of fruit to the large centres of distribution.

Some persons may object that truck rates would be greater than the railway rates, but that is a minor consideration when it is a question of placing the



# CANADIAN MOTOR, TRACTOR AND IMPLEMENT TRADE JOURNAL

Published on the fifth of each month by

The MacLean Publishing Co., Limited  
TORONTO, MONTREAL, WINNIPEG

JOHN BAYNE MACLEAN,  
President.

H. T. HUNTER,  
Vice-President.

H. V. TYRRELL, General Manager.

LONDON, ENG., THE MACLEAN COMPANY, OF GREAT  
BRITAIN, LTD., 38 FLEET STREET, E.C.

BRANCH OFFICES: Montreal, Southam Building, 123 Bleury  
Street; Winnipeg, 1103 Union Trust Building; Vancouver,  
314 Carter-Cotton Bldg., 198 Hastings St. W.; New York,  
Room 620, 1183 Broadway; Chicago, 405-6 Transportation  
Bldg.; Boston, 734 Old South Building.

SUBSCRIPTION PRICE—\$2.00 A YEAR.

OFFICE OF PUBLICATION—143-153 University Ave., Toronto.

Vol. 2 TORONTO, OCTOBER, 1920 No. 10

## Quebec-Hamilton, Let's Go

**P**OWER farming dealers who live in Ontario and Quebec should not fail to attend the tractor plowing matches to be held this month at Macdonald College Farm, St. Anne de Bellevue and at Hamilton, Ont. The Quebec demonstration will be held on Oct. 12-14 and the Hamilton demonstration Oct. 20-22. It is expected that there will be a large showing by the various tractor manufacturers. Besides the plowing matches there will be large exhibits of power farming machinery at these demonstrations. The live dealer will see in these demonstrations a great opportunity of comparing the different machines in action and of meeting with farmers who are interested in power machinery and who, probably, may be his future customers.

## Preventing Fire

**C**LEANLINESS is the surest protection against fire. Almost any day we pick up a paper and read that a certain garage was destroyed by fire caused by—spontaneous combustion in oily rags and waste—automobile back firing set floor on fire—man stepped on match and set oily waste lying on floor on fire—a careless workman or customer threw a lighted cigarette end into an open pail full of gasoline, etc., etc. If cleanliness had been the rule in these garages there would have been no fire. There would be no film of oil on the shop floor; oily waste would not be left lying around; there would be no open pail full of gasoline, and no workman or customer would be allowed to smoke or throw cigarette ends where there is any combustible element. Garage men should insist on a thorough cleaning up periodically and floors scrubbed at least once a week. Metal receptacles should be kept handy where the workman can deposit all dirty rags and waste used during the day, and each night these receptacles should be emptied and the contents burned away from the garage, otherwise the garage man is taking a big risk. Not only is he taking a big risk from fire but customers are liable to be "shooed" away. No one likes to do business with a concern that tolerates dirt and carelessness.

## Neglected Brother of Your Business

**I**N every line there is a neglected little brother—some subordinate item which doesn't get the attention it deserves, says Printer's Ink. Perhaps it's a new arrival that has not been impressed as yet upon the salesmen's consciousness; perhaps it's something difficult for them to sell; perhaps it's something outside the regular line that they take no interest in; perhaps even it's a new little baby that they didn't want at all. Whatever it is, something must be done to help it.

It is general experience that it is very difficult for salesmen to handle side lines, either of their own company or of some other. There was, for example, a spark plug manufacturer who added grease-cups as a side line and turned it over to his salesmen to sell. They talked the spark plug first and then brought out the grease cup. The results were not

### APPROVED ANTI-GLARE DEVICES

**T**HE Ontario Department of Highways has issued the names of twenty-three anti-glare auto devices which the Department will accept as conforming with the anti-glare law passed at last session. The act makes it unlawful for any motor vehicle to carry headlights that throw a beam of light that rises higher from the ground than 42 inches when measured 70 feet from the lamps. The following devices are considered by the Department as meeting with all the requirements of the act. The motorist should choose from this list:—Sun-Ray, Sills (green top), Sills (clear) Holophane, Benzer, Primolite, Violet-Ray, Sunlight, Kopps, Liberty, Macbeth, Clamert, Warner-Patterson, Lee Knight, McBride, Levelite, Raydex, Conophore, (clear), Conophore, (civial), McKee, Osgood, Shaler Road-lighter, Legalite.

The act is effective now but won't be enforced until January 1, 1921. This will give motorists ample time to comply with the act.

satisfactory. Coming up after the customer thought the interview was all done, it did not give a good impression. Some of the salesmen began to forget to talk the side line. A change was made and exclusive salesmen put out handling the grease cup and a separate section of the sales department was made entirely responsible for the sales.

An automobile agency had an accessories department, but found it was selling few tires and was doing nothing remarkable on other items. It occurred to some one to go over the sales records to find out how much in the way of accessories was sold by the salesmen with each new car. The result of the investigation was surprising indeed. Evidently the new owner went off and bought his extra tires, bumper, spotlight, and other "fixin's" elsewhere.

This point brought out, the reason was quite plain. The salesman's commission was based on the net price of the car alone and he received nothing extra for the accessories. A five per cent. commission was then offered the car salesman; and in addition the contract form was modified so that the extra tires and the main accessories were already listed on the form to serve as a further reminder both to salesman and customer.

Thereafter hardly a car went out of the agency that was not well equipped with extras. Indeed it was made a practice to put the extra tires and supplementary equipment on each car placed on display.

The whole problem simmers down to this: All salesmen tend to favor some lines and overlook others. In a line of high-priced articles with one or two supplementary low-priced lines, the latter is neglected.



Still Running Wild.  
—Bronstrup in San Francisco "Chronicle."

It then becomes necessary to find some means of stimulating the interest; or if this is found to be impractical, to make special arrangements for the neglected member's sale.

## Garage Men Read This

**G**ARAGE men are enquiring all the time as to whether a dealer has any recourse against an individual who has been supplied with repairs or had repair work done on his automobile, and for the benefit of the auto accessory dealers and garage men we publish the legislation covering cases of this kind.

It will be seen from Chapter 150, Section 40 of the Mechanics' Lien Act, which is published below, that if an account remains unpaid after three months have elapsed, garage men have a lien on the automobile for which the repairs have been supplied or the work has been done, and they have the right to sell the same on giving one month's notice by advertising in the local newspaper, or if there is no such paper in their locality, by posting at least five such notices as prescribed by the Act, within a radius of ten miles from the place where the work was done, stating the time and place of sale and the name of the auctioneer, and in addition leave a like notice at the residence of the owner of the automobile. Further, they may apply the proceeds of the sale on the amount of their bill, after deducting the expenses incurred, and should there be any balance, it must be returned to the owner.

The following is the Section covering the above:—

Chapter 150, Section 40. Liens for Improvements of Chattels. Every mechanic or other person who has bestowed money or skill and materials upon any chattel or thing in the alteration and the improvement of its properties or for the purpose of imparting additional value to it so as to thereby be entitled to a lien upon such chattel or thing for the amount of the value of the money or skill and materials bestowed shall, while such lien exists but not afterwards in case the amount to which he is entitled remains unpaid for three months after the same ought to have been paid have the right in addition to all other remedies provided by law to sell the chattel or thing in respect of which the lien exists on giving one month's notice by advertisement in the newspaper published in such locality in which the work was done or in case there is no such paper published in such locality or within ten miles of where such work was done then by posting up not less than five such notices in the most public places within the locality for one month stating the name of the person indebted, the amount of the debt, and the description of the chattel or thing to be sold, the time and place of sale and the name of the auctioneer and leaving a like notice in writing at the residence or last known place of residence, if any, of the owner, as the case may be, or by mailing the same to him by registered letter if his address be known.

(2) Such mechanic or other person shall apply the proceeds of the sale in payment of the amount due him and the costs of advertising and sale and shall upon application pay over any surplus to the person entitled thereto.

## Pays Tribute to Business Press

**"T**HAT in the opinion of this Congress, it is desirable that, with a view to the encouragement of closer trade relations within the Empire, special efforts should be made to secure the wider distribution of trade journals throughout the Empire, and that more favorable postal facilities should be accorded by the various governments to this end."

The above is a copy of resolution unanimously passed at the meeting of the British Chambers of Commerce held in Toronto.

This important resolution stands out in bold contrast with the effort put forward by M. E. Nicholls, director of National Publicity for the Government at Ottawa, to legislate the trade and technical papers out of business. In spite of the opposition of M. E. Nicholls and J. E. Atkinson, of Toronto "Star," the Chambers of Commerce of the entire British Empire, composed of many of the best trained business and technical experts, has seen fit to pass this resolution, emphasizing the great importance of the specialized business and technical press to those who would better understand conditions in the various parts of the Empire.



# Implement Dealer Should Sell Farm Trucks

**W**HY is the power farming dealer the logical farm motor truck dealer? You know. It's because he is in closer touch with the farmer and his problems than any other business man in town. He deals exclusively with the farmer. The farmer's problems are his problems—or should be, at any rate. And to-day one of the biggest problems facing the farmer is the matter of transportation—hauling between the farm and the local market and also between the farm and the more distant large markets (in some localities). Good roads and the motor truck will go a long way

By B. J. PAULSON

makes no difference in so far as the necessity for motor trucks is concerned. Of a list of 4,293 replies received to a questionnaire sent out by the Goodyear Company, 252 farmers were found to be motor truck owners and reports from grange masters representing 42,281 farmers showed that of this number 5,298 were owners of motor trucks. It was also found that 42 per cent. of the truck owners also own tractors, indicating that a farmer who had been

render after-sale service that is efficient and that the farmer knows he can depend upon.

**Y**ES, the power farming dealer certainly is the logical man to sell motor trucks to farmers BUT (there's always an unwelcome "but" hanging around some place), but, I reiterate, the power farming dealer isn't always the best dealer to sell motor trucks. Before he can become successful as a motor truck dealer he must first take a lesson in service from the automobile dealer.

The automobile men learned early in the game that service was the big word in selling a machine, the intricacies of construction and operation of which are beyond the average layman. They found that automobiles sold without dependable, always-available after-sale service were unsatisfactory sales. The owners would experience difficulties that invariably made them regret their purchase, resulting in loss of goodwill to the dealer. And so to-day you will find that every successful automobile dealer is a "service station." He employs expert mechanics who know how to adjust and repair automobiles sold by him. He carries on hand a supply of essential parts that are subjected most frequently to damage or wear. The purchaser has assurance of satisfactory performance of his purchase because he knows that service both in the matter of repairs and expert adjustment is always to be had. He does not have to depend upon his own inadequate knowledge.

Yes, this is a lesson that the average implement dealer has not yet learned, but which he must learn before he can sell motor trucks successfully. A motor truck is a source of profit to a farmer only while it is working — and the necessity for keeping it in first-class working condition all the time is more important than in the case of the automobile. The average farmer is not competent to make repairs and adjustments himself, although the tractor-owning farmer has progressed considerably in this direction. If a dealer sells a motor truck without after-sale service the chances are that that truck will be back on his hands before many months—a second-hand truck to be disposed of with the handicap of unsatisfactory service tied to it. The dealer loses money on such business. No matter how good a truck may be, there comes a time in its life when it needs expert attention — and it's up to the dealer to render that service.

So the whole thing resolves itself down to a matter of "Service." The power farming dealer who adopts this as his motto is not only the logical man to sell farm motor trucks, but also the best one.

BE A BEST ONE.



Motor truck hauling grain from threshers to elevator.

towards solving this problem. "Ship by Truck" is becoming a popular slogan everywhere. But trucks must be sold to the farmer by someone — and isn't the implement dealer the logical "someone"?

The internal combustion tractor and its many labor-saving and efficiency-increasing consorts have speeded up farm production to a great extent, but it is impossible for the tractor farmer to get the most out of his tractor equipment unless he speeds up farm operations all along the line, which includes hauling.

Farm hauling with horses, as every implement dealer knows, is a time-consuming job that usually is shunted to one side until seasonal work on the farm isn't pressing — or if the market is high or the farmer is in need of a little ready money, he frequently holds up his farm work while he transfers part of his crop from his granary to the local elevator. In either event, he loses. When grain hauling, for instance, is postponed for several months after harvest an appreciable loss is often sustained through the depredations of rats and mice and through loss of weight by drying out. These losses often counterbalance any slight increase in the market price that might develop several months after harvest. On the other hand, if the market is high at the time the grain is being threshed and the farmer hauls direct from the thresher to the elevator, he is losing money through sacrificing valuable time from his fall plowing, disking, seeding, etc.

**T**HE motor truck will prevent such losses to a great extent. It has been proved conclusively through reliable investigation that farmers owning motor trucks make three round trips to town in the same length of time as other farmers make one round trip with horses — and the motor trucks average a 50 per cent. heavier load than with wagons and cover more mileage. These same investigations also show that the cost of hauling with motor trucks averages one-half and one-third of the cost of horse and wagon hauling.

A recent market analysis of the farm motor truck market in the States by the Goodyear Tire and Rubber Company reveals the interesting fact that 80,000 farmers down there are using motor trucks at present and that 800,000 farmers have considered buying a truck. The analysis shows further that the same general interest in trucks is manifested by farmers in the dairying sections, fruit belt, live stock sections and grain country. In other words, the kind of farming that is being done

educated up to the value of one form of farm power readily falls in with the idea of generally motorizing his farm.

While the foregoing figures are for the States, still the potential farm motor truck market in Canada should be very much the same, in pro rata proportion to population, of course.

And as stated at the beginning, the power farming dealer is the logical motor truck retailer. This great potential market for motor trucks is closer to him than to anyone else. When you sell a farmer a tractor, you are educating him up to the power idea. Thereby half the battle of selling this same farmer a motor truck later on is already won — provided you sell the farmer a good tractor that will give him satisfactory service and provided further that you



For hauling livestock from farm to market the motor truck is becoming increasingly popular.



The small things in a business are often overlooked. The garage man cannot be too careful in checking up the small things, such as bolts, pins, lubricating oil, etc., etc., used in doing repair jobs and seeing that they are properly charged for. Besides these items there are other things which help to keep the profits of the small garage down. The indiscriminate use of waste, electricity, gas, writing paper, etc., form serious leaks in many otherwise good businesses.

Read the following article and if you are an offender in any of the things mentioned, resolve to make an adjustment and you will be surprised at the results. The little things always count.

**P**ROFIT-SHARING events occur on all sides and are familiar to everyone. But there is a certain form of profit-losing not so well known, which is a serious item to small repair shops, and even large ones that have not provided an adequate check system. This is the loss of parts and material used in repair jobs and not charged to the car owners.

The average mechanic is somewhat prejudiced against anything resembling bookkeeping, and small shop owners are likely to feel that too much time is required in carrying out the ideas to make them worth while. Where each mechanic has the privilege of going to the shelves and selecting the parts he needs, a certain percentage is never charged. Even where the owner or foreman selects and turns the parts over to the men, listing the items at his first opportunity, a good many get by.

Especially is this true of small things. Quite a sum of money is lost in a year's time just in such small things as bolts, nuts, lock washers, gaskets, cotter pins, gasoline and kerosene used in washing, etc., which are easily forgotten. For example, you buy a box of 100 3-8-inch cap screws. First thing you know, all are used and you are lucky if you find that 50 of them were charged out. You have lost not what they cost but what you could have charged for them. Don't overlook the small things.

**A** GOOD idea is to check carefully every work card when the job is finished. If a crank case was washed out, see that lubricating oil and kerosene are charged. If bearings were refitted, or work you know required cotter pins and none are charged by the mechanic, add them on. Or if a differential or some part is washed and you know gas was used in washing, see that a sufficient quantity of gasoline is charged. Free use of waste is expensive, although I believe most shops now charge this to the car owner and very few owners object. But do not make a practice of adding little things that were not used or fudging on the amount of grease and oil. Any unfair dealing or cheating is not only dishonest but is a poor business policy and will lose in the end. A certain mechanic got this habit. He said the customer never kicked at the small things he added, hardly even looked at them on the bill, and picking up a dollar or so extra on every job of any size helped to make up for items lost or overlooked. The habit grew from little things to big things, until one day he charged for a new set of piston rings when he had used an old set. The job was far from satisfactory, and this man's assistant, having some sort of griev-

## KEEP TRACK OF THE PROFIT-LOSING ITEMS

By F. H. SWEET

ance against him, told the customer what he had done. The result almost put the man out of business, for it so happened that he tried his trick on the wrong man. He was afraid to fire the assistant, who knew too much. He had to turn over a new leaf and is now prospering as an honest man should and, I really believe, feels indebted to his assistant.

In one shop, employing six or eight men, they have found a practical method of keeping track of parts, in the use of small wooden box with a slot cut in the lid. This box is kept in a convenient place near the parts' shelves. By it is a small pad of blank paper and a pencil attached to a chain to prevent it being taken away. When a mechanic takes any material, he is required to write on one of these slips: First, the date—they usually date a number of blanks each morning with a rubber stamp; next, the car owner's name or license number; then parts of material; and his initials at the bottom. This slip is then dropped in the box.

**I**N addition to this, the mechanic must list the items on the work card in spaces provided. Each work card is kept on the car to which it belongs, being fastened to the windshield by means of a paper snap fastener. After work or the first thing next morning, the cards are taken from the different cars, to the desk, the parts box is opened and all items are checked and properly charged in a short time. The proper working out of this kind of a system rests

largely with the men. Some mechanics are careless or indifferent as to what they use, and these are going to waste their employer's money, while others save a third of their salaries by doing what is expected of them. This shop uses only one style of work card. When a car is brought into the shop, one of these cards is filled in as per the customer's order. Then each line is checked off as the work is completed. The mechanic enters the date, his initials, and the amount of time put in on each job.

For keeping the mechanics' time, small inexpensive memorandum books are used, one for each man, or one book can be used for two or three men. The date is rubber stamped in this book. The mechanic enters under the date the car owner's name and his time for each job he worked on that day. Any time put in cleaning the shop, or lost, will show in this book, as a full eight hours' time for each day must be accounted for.

One book lasts several months and makes a good, permanent record. The books will get soiled and greasy, but mechanics can be trained to wipe their hands before making entries and keep the books as clean as possible. The time books are checked up similar to the parts' slips. Mechanics are required to put down their time as soon as they are through each job, so if a car is completed and goes out, say in the middle of the afternoon, the time and material can be readily checked.

Very little labor or material used in this shop is overlooked.

## Road Transportation Cheaper Than Rail

By LORD MONTAGU OF BEAULIEU

**A** RECENT article in the London (Eng.) Sunday Times compares the present cost of transportation both for freight and passengers by road and by rail and shows that for journeys up to 100 miles road journeys are now cheaper than by railway. Petrol in England costs 84 cents a gallon, on the other hand, the roads are far better than in Canada. But admitting that conditions vary in the two countries this comparison of costs cannot fail to interest Canadians. The article in part runs as follows:

A passenger and a ton of goods cost more to convey now than they have ever before since railways were started some eighty years ago. The point is already reached at which, with certain exceptions, transport by road is being used more and more, because it is actually cheaper. Moreover, the tendency for the cost of railway transport to increase will continue for some time to come, as far as one can see.

On the other hand, our roads will become better as time goes on. Road traffic will be operated as a whole more cheaply, and before long a cheaper motive power other than the motor spirit used to-day will be available. Then there is the advantage of direct delivery from producer to consumer, from origin to destination, which will tell more and more as labor in handling becomes increasingly expensive. The outlook financially and scientifically is therefore distinctly in favor of road against railway transport.

I want my readers to realize, however, that I do not put these facts forward in any sense with an anti-railway bias. Railways are still a necessary part of the transport system of the country, and for certain classes of traffic they remain the best form of transport.

An actual comparison in terms of miles and money

between road and rail transport, according to the prices of to-day, is necessary, and my readers must not forget that railway fares are shortly to be increased by another average all-round rise of about 50 per cent.

To get some idea of the relative costs we will take two classes of vehicles and endeavor to ascertain the approximate costs of running per mile. First of all, there is the char-a-banc or motor-bus conveying anything between twenty to forty people, according to size. Such a vehicle, taking everything—wages, fuel, depreciation, and a fair profit—into consideration, costs about 66 cents a mile, which, with an average of, say, thirty-three passengers—many vehicles take far more—works out at 2 cents per mile per person. This compares with an average of 3 cents per mile for third-class rail fares now charged.

The road journey is slower, but it is more comfortable and cheaper, and on a holiday an hour or two extra does not count. Thus nearly all journeys by road up to, say, 100 miles distance or a day's journey are now cheaper than railway.

Now, we will take as a second instance the motor bicycle—the "useful horse" of the road-using democracy. While one person drives the motor-cycle another can sit behind on a cushion, and sufficient luggage for both of them can also be strapped on. The average motor-cycle will run anything from 50 to 70 miles to a gallon of petrol, and cost less than 2 cents a mile for tires, lubrication, and depreciation. If we put down the cost of running, therefore, at 3 cents per mile, we are on a safe basis, and at this 3 cents a mile the man and his friend or wife can accomplish 150 to 200 miles a day comfortably, as against 3 cents a mile each in third-class fares. In this case the expense of the journey is halved.



# The New Meaning of Tractor Service

By H. O. K. MEISTER

Manager Tractor Bearings Division, Hyatt Roller Bearing Company

section of the country that isn't within shouting distance of a garage.

IN the case of the farm tractor, service cannot be effectively accomplished at a repair shop remote from the farm. A delay of a few days or even hours, often represents the difference between making a crop or failing to make one. Service must be taken to the farm. The most logical way to get service to the farm is through the farmer himself. The work of educating the farmer should begin with the tractor salesman. He should give the farmer reliable information. He should avoid making exaggerated statements.

Again drawing a comparison or rather a contrast to the automobile—a motor car salesman may swear that his car will travel seventy miles an hour—but the chances are that the buyer will never check him up. On the other hand a tractor salesman who claims three bottoms for a two bottom tractor is a menace to the industry. A farmer buys a tractor for busi-

ness purposes. It would be unbusinesslike for him to operate it below the advocated capacity.

that time until he has received the maximum return from his investment. Horses may ultimately become obsolete but there will always be a need for good old-fashioned "horse-sense"—even on the completely motorized farm.

The burden of this educational responsibility lies with engineers, manufacturers, service men and salesmen.

## About Car Prices

THE automobile industry of Canada and the general public as well have been engaged, during the past two weeks in talking about car prices and speculating as to what is going to happen.

Henry Ford certainly startled the public two weeks ago when he announced in flaring headlines in the press that he was reducing his prices to pre-war standards. Since then there have been other reductions and probably there will be some more but so far the reductions have not been serious. On the other hand some big corporations like the General Motors and Packard have decided not to lower their prices. They take the stand that present market conditions do not warrant a reduction. What Henry Ford's motive is in lowering his prices at the present time, considering the general conditions of the markets, is not quite clear. Speaking in this connection the Financial Post says:

"It must be evident that production is not likely to be increased, nor costs reduced merely by the adoption of such a policy. Wages are to be maintained. The plant's production is now oversold. It would seem that Ford has been making large profits, that he is willing to take a loss for a time, or that he feels that he can develop to take care of the increased market which low prices will give him and again adjust to a successful operating basis on a larger scale. In this event, and if the result is more and cheaper cars for the benefit of a large number of people, there can be no objection to the policy.

"Price reductions, however, will come by process of adjustment of all the factors rather than at one fell swoop. But if Ford is leading the way to a healthier basis—and is not precipitating a crisis—and is at the same time prepared to increase the number of owners of low priced cars he will add to the benefactions which an idea and organization have made possible."

Some dealers fear that the public will slow up in purchasing cars expecting lower prices in the future. It is true that at the present moment the automobile industry is experiencing a falling off in sales but it is not alone due to the drop in price. There was a slowing up before the cut came. This slowing up is noticeable in other lines as well as the automotive industry. In the opinion of Mr. Cowan, of the Packard-Ontario Motor Car Co., the public is refraining from buying just now because of the season and the general condition of things. He is of the opinion that there is nothing in the situation to be pessimistic about but rather does he see in the tendency of the public to spend carefully the first sign that things are coming to a proper level. His company has not lowered its prices nor does it anticipate doing so, in fact the Packard guarantee to refund to purchasers of Packard cars or trucks now, whatever reduction is made before July 1921 should the conditions warrant a reduction. Other distributors seen expressed themselves of similar views. Mr. Rouse, of the Automobile and Supply Co., distributors of Paige and Hupmobile cars, said there was a slight reduction in the Paige models but none in the Hupmobile. The Paige prices are guaranteed until July, 1921. Mr. Rouse is of the opinion that prices cannot drop very much for some time to come and with the beginning of the new year there will be a big car business.

THE word "service" was at one time synonymous with "free repair work." This definition has been proved a fallacy because there is no such thing as "free" repair work. Repair work costs money. Repair work costs lots of money. Somebody has to furnish this money and for a number of years the broad meaning of the word itself has been overlooked in an effort on the part of the manufacturer, dealer and user to shift the burden of this expense to the other fellow. The definition of the word "service" in so far as it relates to the tractor industry has undergone an evolution.

Service is a summation of those constructive efforts on the part of the manufacturer and the dealer that effectively aid the farmer in getting the maximum return from his investment.

The farmer wants cheaper plowing rather than cheaper tractors" or "free" repair work.

In this formula the time element is of prime consideration. The cost of a repair part is in many instances negligible as compared with the expensive delays involved. All other things being equal, or anywhere near equal, the usefulness of a tractor is inversely proportional to the time lost on account of repairs.

Service is the first consideration. Since time immemorial in all branches of the automotive industry there has been a tendency on the part of the manufacturer to take the stand that the dealer should assume the biggest share of the service responsibility. The dealer was looked upon as the connecting link—or the "shock absorber"—between maker and user. He was the direct point of contact. He must earn his commission. On the other hand, the dealer assumed the attitude that the manufacturer should build his product so well that it would not require profit-consuming service. Both sides were right. Both sides were wrong. There is, however, one common point of agreement which is beginning to be generally recognized and that is the need of more educational work on the part of everyone.

EVEN if it were possible for some imaginary hokus-pokus to give unstinted free service, the recipient of such service could not possibly derive the same benefit from his tractor as the farmer who knows how to guard against trouble, make an occasional adjustment and do the ordinary repair job without assistance.

The most important function of a service department is to prevent trouble rather than remedy it. A service department properly conducted is the greatest educational influence in the tractor industry. In the case of the automobile the necessity for efficient service was recognized some years ago and service is unquestionably the foundation of the truck industry.

The farm tractor has to withstand conditions never before expected of self-propelled vehicle. The locomotive, for instance, travels on a carefully constructed steel track which is essentially a part of the machine itself. The motor car and truck are equipped with highly resilient tires and other shock absorbing devices which minimize the slight irregularities of the highway. The tractor, in striking contrast, must operate on rough farm lands, blazing its own trail through mud and sand, over prairie stubble and rocky hill country. Irrespective of climate and temperature, it must, under the most adverse conditions, accomplish more work in less time than a corps of husky farm animals. The locomotive is never entrusted to other than experienced hands. An engineer must go through years of experience before he is qualified to handle a train and—in addition—there is a roundhouse and a repair shop within only a few hours run of any point on his division. The automobile and truck are essentially machines for annihilating distance. Troubles that completely cripple them are the exception rather than the rule and at this day and time it is rather hard to find a locality in any

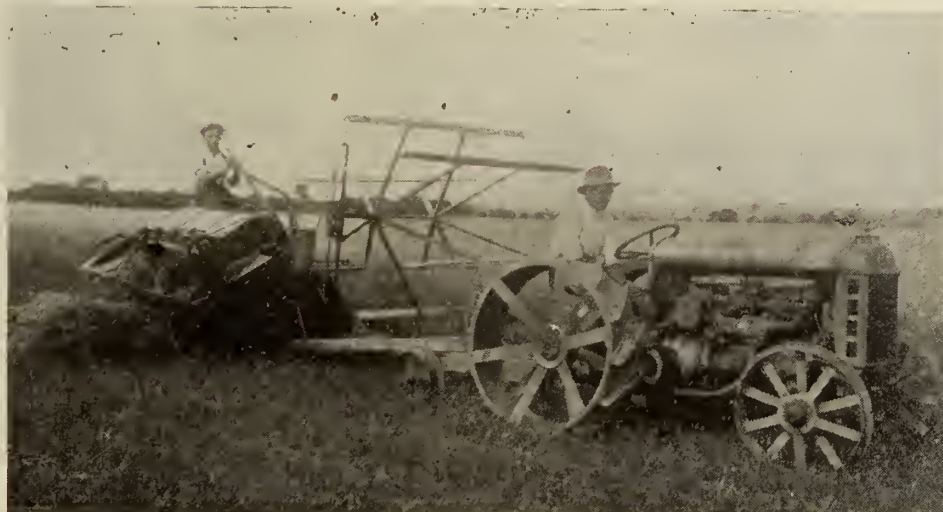

A tractor engaged in harvesting at Macdonald College Farm, Quebec.

ness purposes. It would be unbusinesslike for him to operate it below the advocated capacity.

The tractor salesman has overlooked his greatest field of usefulness if he is not an educator. He should work in closer co-operation with the service department. When the farmer has trouble he calls on the service man to remedy it—not the salesman. Therefore the service department should have something to say regarding the claims and promises of the ultra-enthusiastic salesman. When a man resorts to untruths or to promises which he knows cannot be fulfilled it is an admission that he is lacking in real sales ability.

IT is decidedly unfair to draw a comparison between power farming and animal farming until the farmer becomes as thoroughly conversant with one as he is with the other. The farmer needs educational service. He is receptive towards such service. He must be trained to understand his tractor just as thoroughly as he understands his horse. A farmer would not think of taking chances by experimenting with his live stock. He would not try to sustain a pedigreed equine on mildewed oats—neither would he allow it to drink stagnant water even if the animal itself were willing to take a chance. However, the same farmer will unhesitatingly operate his tractor without the air cleaner just to see what will happen and the chances are that he will use an inferior lubricating oil unless he has been properly instructed. What would happen to the old time-honored methods of agriculture if the farmer didn't know any more about horses than he does about tractors?

It is my conviction that the greatest future progress of the power farming machinery industry lies in giving the farmer educational instruction—not only at the time of delivery, but before that time and after



# Adjusting the Disk Harrow Tractor Hitch

By F. N. G. KRANICH

ONE of the farm papers some years ago printed the following sentence with reference to the disk harrow: "Next to the lead pencil the disk harrow is the most important implement on the farm."

This statement has always come to mind when I saw a disk harrow. At first it seemed to me that it was putting it a little too strong. I couldn't quite get the plow, the binder and the thresher out of my mind. I thought perhaps the party who made

12½ inches. The tractor drawbar, therefore, is adjustable, and should be set about this height. On tractors where the drawbar is much higher it is good policy to use a chain, eight or twelve inches in length, between the drawbar on the tractor and the disk harrow draw eye. This reduces the tendency to lift the front of the disk out of the ground, which would

attaching the disk to this directly. In this case turning isn't quite so convenient, neither is moving from field to field so easily and quickly accomplished.

It is plainly evident that for a disk blade to do good work and have light draft its edge must be set at an angle so it will cut the soil straight, as shown in Figure 3. In this case, too, it has better penetration. It keeps its edge sharp for a longer period of time. When it does strike an obstruction—a hidden stump, a piece of wood or a stone—it is not nearly so apt to be cracked and broken. Then, too, the strain and stress on the whole machine is reduced to a minimum for the work accomplished.

It can readily be seen that when skidding through the soil the disks have a decided tendency to pack the soil sideways. Therefore, instead of really mellowing the soil and mulching it, the reverse is what happens. I have said that the draft would be increased. In one sense it would be reduced because the disk runs shallow; what was meant was that the draft would be more for the same depth, because it then becomes necessary to add weight to the harrow to get the same penetration. This added weight causes the added draft. Therefore, besides doing poorer work, its added draft means power loss and more expense.

In our present power-farming era the disk harrow has found a place as a valuable part of the farmer's equipment. As all horse-drawn implements ultimately will, it has already evolved into a special tool for use with the tractor. The present double-disk harrow is a valuable machine and needs good care to get good results from it. It works in the dust and dirt, and great care should be exercised to keep its chilled-steel or wood bearings well lubricated and in good condition. It should be carefully gone over each day before starting out. The entire lot of grease cups should be filled and these grease cups should be screwed down a trifle every hour or two during the day's work. Delays due to stoppage to repair, to adjust or to oil are an expense. This is particularly noticeable when we consider what it means to stop a tractor of from eight to fifteen drawbar horse power every time adjustments must be made or oiling is necessary.

The matter of draft is a big one. So many factors influence this problem that no definite rule may be given that will hold good in all conditions. The angle at which the disks are set has the greatest influence on the draft. The lubrication and condition of the bearings have an influence. Added weight,

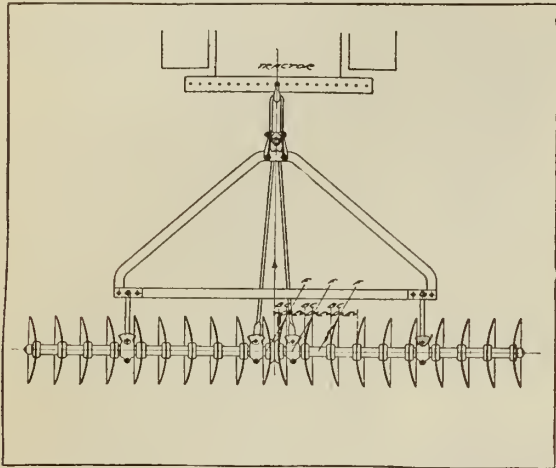

Fig. 1.

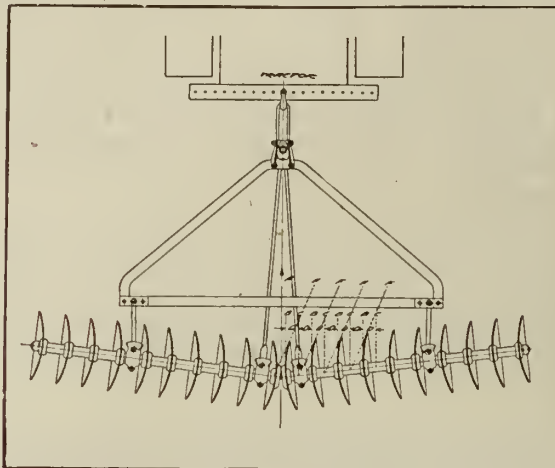

Fig. 2.

the statement had an axe to grind. Such, however, I know now was not the case.

King says: "The early stirring up of the soil in the spring, preparatory to seeding, has for its main object the changing of the soil texture so that it will become: First, warmer; second, drier; third, better aerated; fourth, better suited to lessen the rate of evaporation of the deeper soil water."

A disk harrow in a measure can do this. It can mellow the soil. It can open and aerate the soil particles. It has the capacity to do this work because of its peculiarly shaped disks and the angle at which they work. There is no harrow which so thoroughly pulverizes a soil in the spring after fall plowing as this tool, nor is there a farm tool that can do more good before and after spring plowing than the disk harrow.

It has its limitations, of course. The depth it can reach is a factor that prevents its use to displace the plow. Its limitation in some very hard soils, too, also handicaps it for plowing.

Anyhow, it was never made to do the work that should be done by, and rightfully belongs to, the plow. Its field of usefulness lies in the fact that with the plow it can serve to make an ideal seed bed. The disk harrow has another function, or the same one, but in other terms—that is, to mulch the topsoil. To conserve moisture is one of the greatest of our farm problems.

When it is found that, owing to weather conditions, it becomes impossible to plow early in spring, a thorough disking is a means of saving a lot of moisture. King says that "the disk harrow is one of the best tools for early use in the spring to work the soil and develop mulches."

THE disk harrow is one of the most simple of implements to hitch to the tractor. In the first place, the harrow has its draw eye located centrally with reference to the frame and its draft. This, first of all, means a hitch without side draft on the drawn implements.

Cutting, as harrows do, a width which in practically all cases exceeds the extreme width of the tractor, the harrow can be hitched to the centre of the tractor drawbar. This entirely eliminates all side draft on the tractor. We, therefore, have an ideal combination of farm power equipment and one of the most simple.

Hitching a double disk to the tractor, however, calls for care in getting the correct height. When no forecarriage is used on these implements the drawbar should be very low. Disks rarely exceed 20 inches in diameter, and more often are 18. It follows that the centre line of pull should theoretically come in the centre of the disk. The average height of the drawbar eye on a disk harrow is about

require weighting to get penetration. In fact, using a chain is often the remedy for lack of penetration of the forward gangs.

What has been said about hitching double-disk harrows to tractors refers also to the present horse harrow which has the customary forecarriage as a part of its equipment. The chains are rarely necessary in such cases, however, because of the extra length of this forecarriage rig. Yet, if trouble should arise, lengthening the hitch would help and enable the operator to get good penetration without adding weight. Weight added to the harrow increases the draft, as will be explained later in this paper.

Hitching two double-disk harrows behind the tractor is a little more difficult. One of the best devices for this combination is to hitch on each side separately. In this case the drawbars extending to the left and right at the rear of the tractor are hinged to swing vertically. This permits passing through gates from one field to another by simply

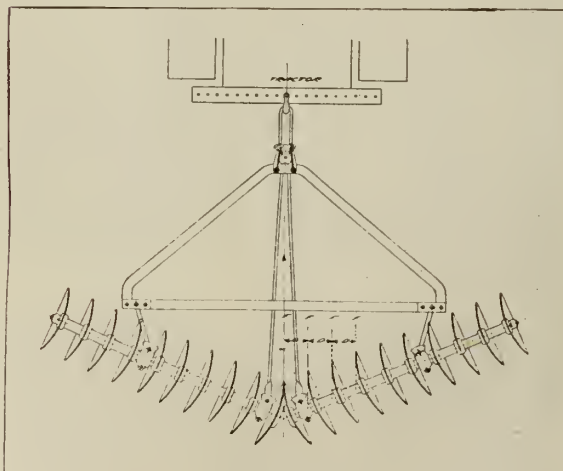

Fig. 3.

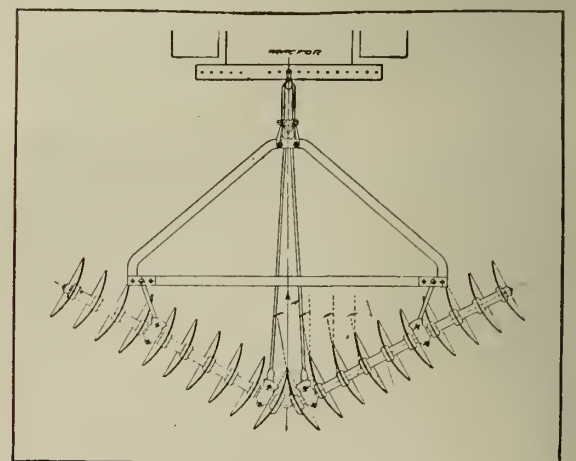

Fig. 4.

hooking these drawbars up in a vertical position. The disks are hitched near the end of the chain which supports these arms. These drawbars can be adjusted to get a high or low hitch for the harrow.

The disk harrow is attached in the usual manner. The disks are set as close as convenient to cover the ground completely. This device permits turning the tractor either to the right or left without danger of the disk conflicting. If a spring or pegtooth drag harrow is to be used in combination with the two double-disk harrows, their draw chains are secured directly to these extending drawbars.

Some farmers prefer using a long heavy oak or Southern-pine drawbar about 12 or 14 feet long, and

as shown above, due to too much angle to get penetration, means added draft. Trying to work wet or very damp plowed ground causes increased draft, too.

ON a test of a ten-foot disk harrow with bearings run without lubrication and another well lubricated the difference in draft was nearly 150 pounds. In another test, using a ten-foot, double-disk harrow, disking before plowing and after plowing, it was found that the draft was about 425 pounds more when disking the plowed ground. This is due to the fact that the disks are able to enter the ground bet-

Continued on page 35





# Primrose

Primrose Separator popularity reaches into every section where there are cows and milk and cream. Each sale made by the agent—each Primrose established in the hands of a new owner—makes future business the more secure. Primrose quality and efficiency is nowhere denied.

Nevertheless it is true of Primrose agents that Providence helps him who helps himself. Help yourself to scores of sales with the aid of our advertising campaign. Supply the branch house with a list of Primrose prospects. To all of them we will mail a series of catalogs, folders, etc., unusually attractive, printed in colors, full of strong selling features. In addition, we will furnish you with a display for your show window, newspaper advertisements, reading notices for your local newspaper, demonstration tags, etc.

This comprehensive campaign goes with every Primrose contract. Primroses sell fast and may be made to sell faster. See the blockman.

## INTERNATIONAL HARVESTER COMPANY

OF CANADA LTD.

HAMILTON CANADA

WESTERN BRANCHES — BRANDON, WINNIPEG, MAN., CALGARY, EDMONTON, LETHBRIDGE, ALTA., ESTEVAN, N. BATTLEFORD, REGINA, SASKATOON, YORKTON, SASK.

EASTERN BRANCHES — HAMILTON, LONDON, OTTAWA, ONT., MONTREAL, QUEBEC, QUE., ST. JOHN, N. B.

## Help Your Customers Build Up Their Land with McCormick or Deering Manure Spreaders

There is every good reason why the farmers of your territory should build better crops by building up their soil with manure—valuable plant food that will give life and strength to healthy seed. And there is no better or quicker way to spread manure than with a **McCormick** or **Deering** manure spreader.

We are making them realize that much depends upon even, uniform spreading. Spreaders bearing the names **McCormick** and **Deering** are noted for their thorough pulverization of the manure and for even spreading. This is backed by practical facts. It is due to the effective operation of the positive apron feed, the chisel-pointed steel teeth of the fast-working, broad-diameter steel beater, and the spiral wide-spreading attachment, which gives the manure a second beating, as it distributes it finely and evenly well beyond the wheels on both sides.

Our advertisements refer readers to the nearby International local agents. We tell them that you will be glad to tell them more about **McCormick** and **Deering** spreaders. Let us co-operate with you to the fullest extent in the sale of more manure spreaders.



## INTERNATIONAL HARVESTER COMPANY

OF CANADA LTD.

HAMILTON CANADA

WESTERN BRANCHES — BRANDON, WINNIPEG, MAN., CALGARY, EDMONTON, LETHBRIDGE, ALTA., ESTEVAN, N. BATTLEFORD, REGINA, SASKATOON, YORKTON, SASK.

EASTERN BRANCHES — HAMILTON, LONDON, OTTAWA, ONT., MONTREAL, QUEBEC, QUE., ST. JOHN, N. B.





# SHOP NOTES FOR THE GARAGE MAN

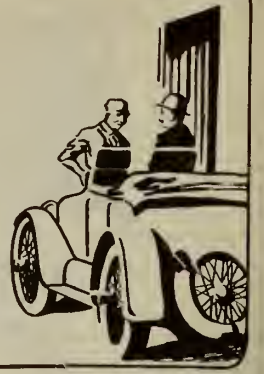

## VALVE GRINDING TOOL

REPAIRMEN who have experienced the difficulty of regrinding the valves in the rear cylinder of the Ford engine with the ordinary valve grinding tool have often been compelled to devise a tool that would handle this operation successfully. A simple tool that can be made by any repairman is here illustrated. It is constructed of cold-rolled steel stock 5-16 or 3-8-inch in diameter bent up as shown in sketch.

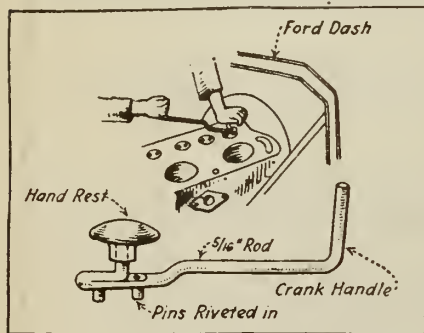

An off-set is provided to carry the hand rest, which may be made of a small door-knob or a piece of hardwood turned to the proper shape. The hand rest should be of free fit on the upwardly extending off-set, working on the principle of a carpenter's boring brace. A grinding handle is provided, and the pins which fit in the holes in the valve head are inserted in a slightly flattened section and riveted in place.

## TO MAKE A HOLE IN GLASS

MAKE a circle of clay or cement rather larger than the intended hole; pour some kerosene into the cup thus formed, ignite, place the plate upon a moderately hard support, and with a stick rather smaller than the hole required, and a hammer, strike a rather sharp blow. This will leave a rough-edged hole, which may be smoothed with a file. Cold water is said to answer even better than a blow.

## SPEEDING UP TIRE DEFLATION

THE repairman often spends time waiting on a tire to deflate, which could be used to better advantage. The wire tool shown in the illustration

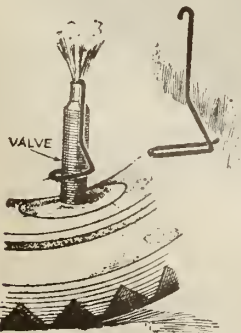

holds the tire valve open allowing the air to escape rapidly. The tool is simply a short piece of stiff wire with a hook on one end to hold the valve open, and a loop on the other end to catch on the threads of the valve stem.

## TEN COMMANDMENTS IN VULCANIZING

1. ALL fabric surfaces must be dry before applying cement.
2. The first coat of cement must be applied thin.
3. Cushion stock must be applied in every case regardless of size of repair.
4. It is necessary, after building up the injured part of the tire, that all the air be removed from the fabric, cushion and breaker fabric before applying the tread stock.
5. It is absolutely necessary to work according to specifications laid down by the factory in curing our repair materials.
6. It is not possible to mix cements fabrics and gums of different manufacture and get good results.
7. Steam gauges must be tested often to get accurate knowledge of temperature. We advise the use of a thermometer.
8. Vulcanizing equipments should be cleaned at regular intervals to eliminate the danger of trapped air and condensation.
9. Proper containers should be built in every shop to keep stock clean and free from dust.
10. If difficulties do arise do not blame the materials until a sample of the trouble has been sent to Head Office and investigated.—Goodyear Tire News.

## REMOVING MOTOR TRUCK WHEELS

A DEVICE for removing motor truck wheels if the dual type and especially serviceable where one man has to do the work, is made from a two-inch plank, cut to the desired

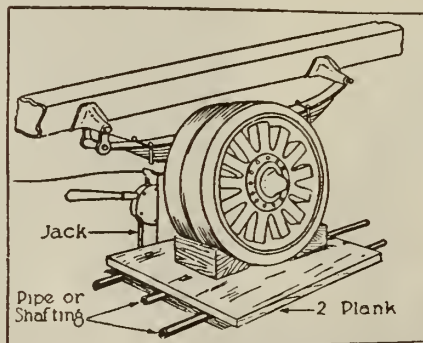

length and width. Jack up the wheel several inches from the floor, lay four rollers, made from either iron pipe or old shafting, on the floor beneath the wheel, place the plank on top of them and chock the wheel at each side. After the wheel has been loosened on its axle it can be easily adjusted on the movable platform for further work.—Automobile Journal.

## TO STRAIGHTEN RADIATOR PINS

A HANDY tool for straightening the pins on water-tube or tubular radiators is made by welding two pieces of 4x1x1-8-in. steel at right angles to the nose of a pair of blacksmith's tongs, so that the faces of the steel pieces will be parallel. Such a tool will do a nice job of straightening no matter how badly the pins are bent.

## SOLDERING STAND

HERE is a soldering stand which any garage man can make. It is constructed of one-half of the differential housing of an old car fitted into a heavy base plate. A tin plate with a

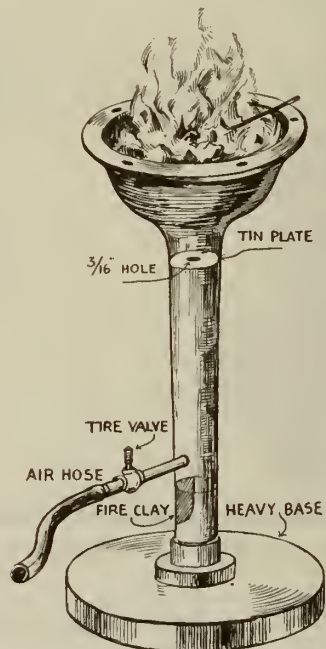

A tin plate fitted inside of the round part of the housing, near the top, holds the coke.

3-16-inch hole is fitted inside of the round part of the housing near the top to hold the coke. A piece of tubing and small length of air hose fitted with an ordinary tire valve to regulate the air, supplies the draft for the fire.

## BATTERY TESTING VOLTMETER

THE Weston Model 443 battery testing voltmeter is a new device placed on the market by the Weston Electrical Instrument Company, Newark, New Jersey, for meeting practically every requirement of the battery service station.

The case is made of Bakelite and is acid proof. The makers say the scale is very legible and dependable readings can be made throughout the entire scale of 0 to 3 volts. The instrument is in addition calibrated so that a portion of its scale—to the right and left of zero—is specially divided and figured for making the Cadmium test. The ordinary method of using the instrument is to attach the small spike terminal to the lower binding post (as shown in the illustration). With the instrument held firmly in one hand and in position that the scale is visible, the spike can be jabbed into any part of the circuit under test. The connection is completed through the cable having the spike terminal, which is connected to the other binding post. Any errors in the zero position of the pointer can instantly be corrected by means of the zero correcter, which is located in the back of the instrument.

## ATTACHMENT FOR ADJUSTABLE WRENCH

NO matter how many solid wrenches are about, there is always room for the adjustable wrench—and the fact that a man needs to have only one with him under a car to handle a number of nut sizes makes the adjustable wrench the favorite in most cases. This applies with equal force to the car owner who is doing his work at home and to the garage mechanic.

The chief objection to the adjustable S wrench, or the monkey-wrench, is its changeability; a touch on the screw or the jars of service turn the screw enough to make the opening too large or too small, though for the first pull or two it was a nice fit. This is particularly exasperating when the tool is being worked at arm's length or out of sight. If only the screw would not move, the S wrench would possess most of the desirable features of the solid wrench.

A simple attachment described herewith will convert the adjustable wrench into a satisfactory solid wrench for the time being. A No. 8 tapped hole is put into the head of the wrench near the adjusting screw, for a round headed screw which holds a spring which may be made from a piece of a hack saw blade. The blade must be softened to drill the hole through and while it is hot it is given a slight "camber" and the end is turned up for the thumb spot. The camber of the spring causes it to hug the screw with enough pressure to prevent its jarring, but the pressure is not so great as to interfere with being turned around out of the locking position by the thumb when so desired. This attachment is well worth a trial—usually the owner feels that it pays for itself in an hour's time.—Automobile Dealer and Repairs.

## TESTING INNER TUBES

A SIMPLE method of testing rapidly the inner tube of a tire is shown in the accompanying illustration. The tube is blown up to a pressure sufficient to hold its shape when set up resting against a wall as shown. A hat pin or some similar object is stuck into the wall above it so as just to touch

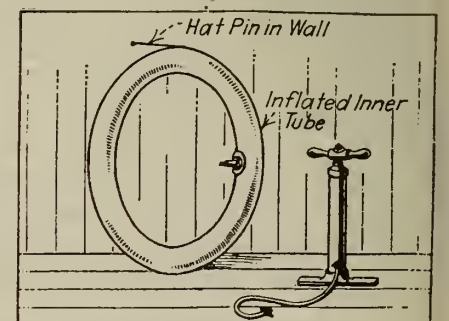

the rubber at the highest part of the tube. The smallest leak will show in five minutes by the tube sinking away from the pin. It is a much quicker and surer way of testing a tire than the method of hanging it up over night. It is safe to say if the tire does not sink from the pin in five minutes it is airtight.



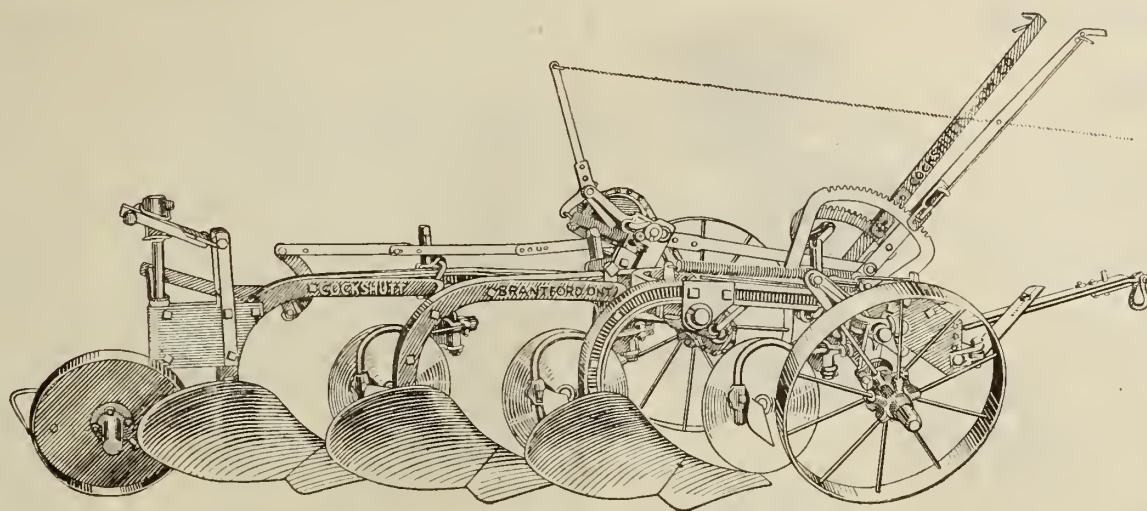

# Cockshutt Tractor Plow

The easiest sold Plow in Canada to-day. Its reputation for splendid plowing in any soil and with any make of Tractor makes it one of the best "self-sellers" you ever handled.

An implement specially designed by experts for tractor plowing. Has heavy beams, heavy braces and substantial construction all through —yet it's surprisingly light in draft. This is due largely to the correct design of the bottoms—they turn clean-cut furrows. Two

easily reached and readily operated levers set the plow for its work. Can be hitched to any make of Tractor. Adjustments up and down as well as sideways are provided. A plow that "stays sold" and makes firm friends for you with your customers.

Built in 2 and 3 furrow sizes with 10", 12" or 14" bottoms. We have larger sizes in independent beam plows, and a big line of Tractor Disc Plows and other Tractor implements. Let us send you full particulars.

## Cockshutt Plow Co.

LIMITED

Brantford      Winnipeg  
Regina      Calgary      Saskatoon

*Sold in Eastern Ontario  
and Eastern Canada  
by*

## The Frost & Wood Co.

LIMITED

SMITHS FALLS, ONT.  
Montreal      St. John

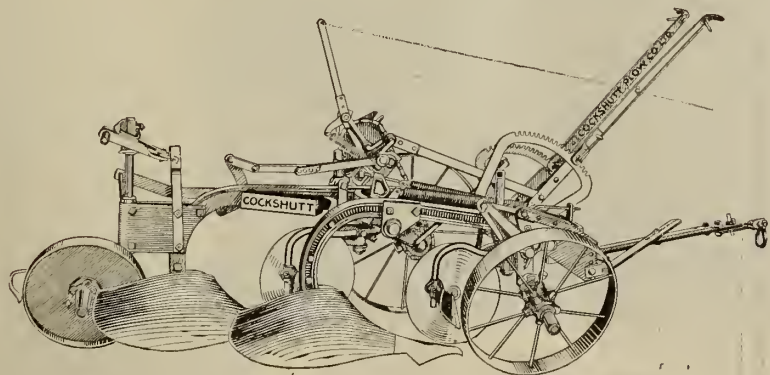

This is one of the most popular of a complete line of Cockshutt and Frost & Wood implements. Backed by big advertising and Dealer Service that never lets up.



## As strong as its plates

A Feed Grinder is a serviceable machine only when its grinding plates are serviceable.

What your farmer customer is looking for when he enquires for a feed grinder is a machine that will reduce grain to any size desired and do this day in and day out. Even though he doesn't realize it, what he is most keenly interested in is the grinding plates.

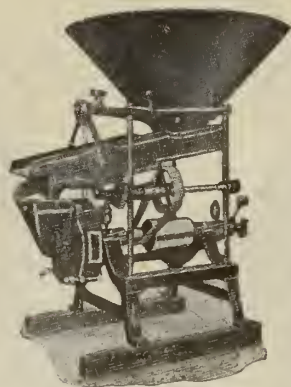

The Famous "VESSOT" Grinding Plate

We challenge the world to produce better - cutting, longer-wearing plates than the "Vessot." No matter what size "Vessot" Feed Grinder your customer decides on, he will get the same quality plates, each marked with the "S.V." that denotes the genuine "Vessot." Sell the "Vessot" Feed Grinder to the customers you want to keep.

The nearest branch of the International Harvester Company will give you particulars of the "Vessot" Agency.

INVENTORS AND MANUFACTURERS

**S. Vessot & Co., Joliette, Quebec**

Sold exclusively in Canada by

International Harvester Co. of Canada, Limited.

Branches: Calgary, Edmonton, Lethbridge, North Battleford, Regina, Saskatoon, Yorkton, Brandon, Winnipeg, London, Hamilton, Ottawa, Montreal, Quebec, St. John.



## The Plug with the HOTTER SPARK

The ball point of the "M & S" plug creates a larger and hotter spark, causing more complete combustion. This hot spark will give your car new life and more power.

The three-in-one terminal is adapted to any style ignition wiring. The high-grade chemically glazed porcelains are interchangeable — one porcelain fits all plugs.

### Models

- 500— $\frac{1}{2}$ " Standard
- 501— $\frac{3}{8}$ " Standard
- 502— $\frac{7}{8}$ " Long
- 503— $\frac{7}{8}$ " Long with Chevrolet Terminal
- 506— $\frac{1}{2}$ " Long
- 504—Regular Porcelain
- 505—Chevrolet Porcelain

**DEALERS**—The "M. & S." plug is standard equipment on the new Overland "4". Ask your jobber for them.

**Machine & Stamping Co., Ltd.**

1209 King Street West  
TORONTO  
Commercial Dept.  
Russell Motor Car Co., Limited

### J. I. CASE PLOW WORKS COMPANY MAKES AGENCY CHANGE

IT is announced that the advertising account of the J. I. Case Plow Works Company, at Racine, Wisconsin, is being handled this fiscal year beginning July 1st by the McJunkin Advertising Company, Chicago. Joseph Finn, in charge of the account at the McJunkin Agency, recently sent a staff of McJunkin men to accompany a party conducted in July and August by C. C. Younggreen, advertising manager of the J. I. Case Plow Works Company, through many counties of Iowa, Nebraska and Kansas. The tour of the advertising men was a complete success. First hand information was secured regarding the work of the Wallis Thresher, Wallis Tractor, and of the plows and tillage tools of the J. I. Case line of implements. A photographer accompanied the party and views of the machinery in action were added to the fund of inspiring information and field reports secured.

### NEW PLANT FOR FORDSONS

THE Ford Motor Co. will erect a million dollar tractor assembling plant in Kansas City adjoining the present assembling work with a daily capacity of 100 Fordsons. It will have a floor space of 200,000 square feet and will employ 600 men. Construction will probably be finished within six months. Peter F. Minnock, manager of the present assembling plant, will be in charge of both the tractor and motor car operations.

### COQUITLAM BURNS

The business section of the town of Coquitlam, seventeen miles east of the city of Vancouver, B.C., is reported destroyed by fire recently. Several stores, a hotel and the fire hall are said to have been burned. The loss is estimated at \$100,000.

### CANADIAN RAYBESTOS COMPANY

THE Canadian Raybestos Company is the Canadian offspring of the Raybestos Company, of Bridgeport, Connecticut. It has purchased two plants at Peterboro, that formerly were occupied by the Lundy Tool and Shovel Company and that of the Henry Hope and Sons, of Canada. Machinery has already been installed in the Lundy plant and manufacturing operations have been begun there on a small scale.

On Friday, July 30th, the first loom was started in a testing operation and the crew wove the first strip of asbestos brake lining ever woven in Canada. This company is the pioneer in this kind of asbestos weaving.

According to E. F. Kelley, superintendent, the company's plans for expansion are extensive and embrace covering the present property with buildings within the next five years which would practically double the present capacity of the plant.

That the company may introduce the manufacture of some article other than asbestos brake lining is likely, though what this article will be has not yet been disclosed.

### ELIMINATE DUTIES ON IMPLEMENTS

THE elimination of the duties now levied on farm implements entering this country and the taking off, within five years, of duties now levied on British goods coming into Canada, was asked for by representatives of the United Farmers of Alberta, who appeared before the Tariff Commission at Winnipeg, September 15, according to a Canadian Press Despatch.

### FIRE DESTROYS GARAGE

FIRE of unknown origin recently destroyed in Saskatoon a garage, motor car and quantity of contractor's supplies, owned by George W. Wheton. No insurance was carried.

### TALK ON SALESMANSHIP

"THE best way to get even with an unreasonable customer is to sell to him and get his money," said J. O. McIntyre when addressing the motor dealers' section of the Vancouver Board of Trade recently on the subject "Salesmanship."

"There is a feeling of pessimism throughout the world today and there is no reason for it," declared the speaker. "It might be that sales are harder to make, but the country is prosperous and sales can be made. One thing that a salesman must never do and that is lose his ambition."

"The worst example of ambition is that of a greyhound chasing a rabbit and both walking. Salesmen must never let their ambition lag. Very often you are just on the point of putting over a sale when you give up. Never quit."

"Man's desire to buy any single article is of short duration. Any movement is hard to imitate but once it starts it attains its object or runs past it. And so it is with man when he is in the mood to buy. Keep after him before he loses the desire to purchase your article. You must use the principle of determination coupled with action," he concluded.

### AUTO DISPLAY AT VANCOUVER FAIR

UNDER the auspices of the Vancouver Automobile Dealers' Association a large automobile show was staged at the Vancouver Fair from September 11 to September 18. Automobiles and motor trucks comprising 80 different makes were housed in the big "L" building at the exhibition grounds. Twenty or more accessory dealers also participated in the exhibition.

### ONTARIO'S FIRE LOSS

ONTARIO'S fire loss for July this year totalled \$676,297 against \$1,028,833 during July last year. The fire loss for the seven months of the year aggregated \$5,842,536 as against \$6,843,788 last year. The above figures emphasize the need for a more general use of efficient lightning rod systems. The loss where such systems are installed is practically nil.

### HESSE BROS. GARAGE

THE new garage recently opened at Wilcox, Saskatchewan by Hesse Brothers, is a great acquisition to Wilcox. It is situated right in the centre of Main street and is 100x50 feet. The repair room is in the basement, where some of the most modern appliances have been installed. A feature of the building is a specially built dust-proof paint and varnish room. J. Hesse is an expert in painting and remodeling and all work will be guaranteed. Hesse Brothers are all round automotive men, having the agency for Dodge cars, Advance Rumely tractors and Ideal separators.

### TRACTORS IN SASKATCHEWAN

THE farmers of Saskatchewan have purchased tractors to the value of six million dollars this year, according to an estimate made by some prominent Regina dealers. The demand for tractors has been exceedingly good and much in advance of any of the preceding three years. Some difficulty is being experienced to secure supplies fast enough to meet the demand.

### FARMER'S OPINION

"IF you ask me," said a real farmer, "what is needed in Ontario is more practical demonstrations on the farms as to the way things ought to be done. Either the Government or the agricultural implement manufacturers should make them. And if that suggestion were carried out it would do more good in the way of crop production than all the agricultural colleges that ever were instituted."



# Makes Short Work of Corn Husking

CORN husking and fodder shredding is just one more of the many jobs of farm work best done with the power of a Case Kerosene Tractor. Just another instance of the remarkable adaptability that makes Case Kerosene Tractors salable in every month in the year. Day after day—job after job; the "Case," under proper management is always busy.

Case Kerosene Tractors are built in standardized design in 10-18, 15-27 and 22-40 H. P. They are similar in all essential features, differing only in such details as are necessitated by differences in size and power.

All have the snappy, flexible, four cylinder motor, mounted crosswise on the frame; forged, cut-steel, spur gears, running in housings that exclude all dust and grit and retain a supply of lubricant; the Case Air Washer (patented), which prolongs the life of the motor by delivering clean air from which all dust and grit has been washed and strained.

Write for catalog showing all the reasons why Case Kerosene Tractors are profitable to the dealer who sells them and the customers who buy them.



Look for the  
EAGLE  
Our Trade Mark

To avoid confusion, the J. I. CASE THRESHING MACHINE COMPANY desires to have it known that it is not now and never has been interested in, or in any way connected or affiliated with the J. I. Case Plow Works, or the Wallis Tractor Company, or the J. I. Case Plow Works Co.

**J. I. CASE THRESHING MACHINE CO.**

(INCORPORATED)

O-10, 345-9 Dufferin St., Toronto, Ont.

Making Superior Farm Machinery Since 1842

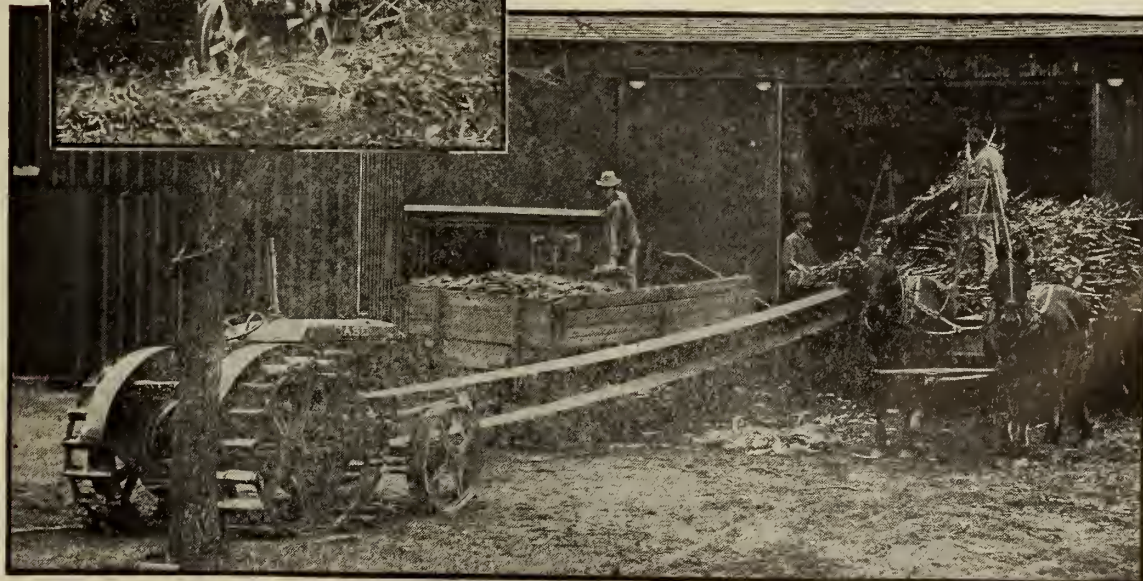
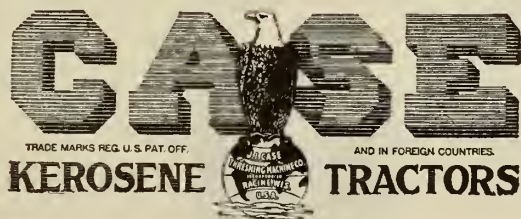



# Automotive Accessories and Implement Equipment



## VALVE GRINDING COMPOUND

THE Northwestern Chemical Co., Marietta, Ohio and Montreal, Que., Canada, have added to their line of nationally known automotive utilities Three-an-One Valve Grinding Compound, holding three ounces coarse and one ounce fine. The makers say it contains no ground glass, sand or emery—but does contain the highest grade abrasive obtainable. In order to grind valves quickly and uniformly the mechanic must use a high grade valve grinding compound.

The three-an-one can is unique. By removing the lid one has access to the fine grade and by removing the fine grade compartment one has access to the coarse. Both compartments face-up and you don't have to keep reversing the position of the can when you want to change from one grade compound to the other.

## AMES HOLDEN TIRE CO.

CONVINCED that there is a big future for the Canadian automobile trade and to provide for the increasing demand for automobile casings and tubes, the Ames Holden Tire Company have built and equipped at Kitchener, Ont., a modern tire manufacturing plant. The sales organization of Ames Holden McCready Ltd., is available for marketing the products of the Ames Holden Tire Co. throughout Canada. The tire being manufactured by this company has a distinctive tread as will be seen from the illustration showed herewith. This is known as the "Universal" tread and many advantages are claimed for it. Tubes, both grey and red, are also being manufactured. The officers and operatives of the company are said to be experienced tire men, and "Canadian from the ground up" is the proud claim of the company.

## LUXURY SHOCK ABSORBERS

THESE shock absorbers are designed for Ford cars. They are of double spring construction and are easy to install. No holes are required to be drilled, they are just bolted on as shown in the illustration. They are manufactured by the Specialty Device Co., 106 W. Third St., Cincinnati, Ohio.

## TRANSMISSION BAND SPRING COMPRESSOR

THE Roberge transmission band spring compressor is used for replacing the cover on Ford transmission. It compresses all three springs at the same time and leaves a space of one inch on each of the springs, allowing plenty of room for the bands to slip in place. In using this tool place the transmission cover on the floor or work bench, unscrew the nuts on the ends of the shafts as far as they will go, press springs together with the compressor. The link in the top of the handle will hold the tool in position while replacing the cover.

This device is manufactured by the Roberge and Sons Manufacturing Co., Dallas, Texas, and distributed in Canada by the Independent Electric Company, Ltd., Regina, Saskatchewan.

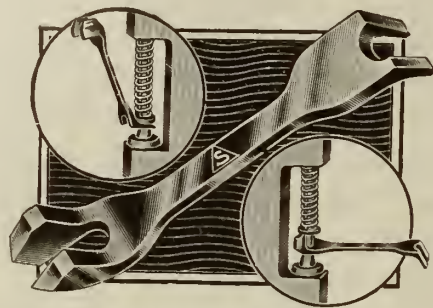

Valve Lifter for Ford.

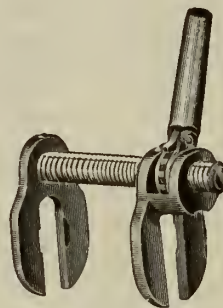

Morgan Utility Tool.



Transmission Spring Compressor.



Three-an-one Compound.

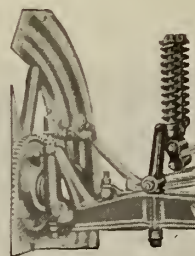

Luxury Shock Absorber.



Ames-Holden Tire



Transmission Band Adjuster.

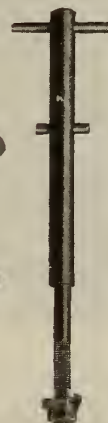

## MORGAN UTILITY TOOL

THIS tool is designed for a variety of uses in the repair shops. The makers say it can be used as a hand vise, a drill jig, as a valve lifter and as a patch press.

It is of strong construction, with a steel stamped base; the screw is machined from cold rolled steel; the sliding part is a malleable iron casting. The handle is of steel, pressed up and riveted together; the nut is a brass screw and the ratchet is reversible.

The tool is rust proofed and locks automatically in either direction. It is manufactured by the Morgan Manufacturing Co., Inc., Keene, N.H., U.S.A.

## VALVE LIFTER FOR FORD

STEVENS and Co., 375 Broadway, New York City, N. Y., are offering to the trade their new valve lifter for use on Ford engines, and which, they claim, is easy to operate and will give sure, quick results, and owing to the construction of the two ends will successfully handle the operation of taking out the pin or assembling the spring without the necessity of removing either the manifold or carburetor.

The manufacturers state their new product is entirely made of metal in one solid piece, one end being of a wedge-shaped design, which instantly forces the spring up so that the pin may be easily removed. The tool may then be left in this position while the valve is being ground, thus enabling the operator to replace the valve and pin without annoyance.

The other end of the tool, the manufacturers describe as having a hammer claw end which they claim will instantly raise the spring off the push rod guide, and with a quick upward thrust will lift the spring past the pin hole. The length over all is 6½ inches.

## TRANSMISSION BAND ADJUSTER

THE Strong Transmission Band Adjuster is designed for adjusting the brakes on Ford cars. The makers say the "Strong" makes it possible to adjust the brakes in one minute at any time under any conditions and by keeping the brakes in proper adjustment, the life of the transmission band is lengthened considerably.

The device is easy to install and is made from cold rolled steel turned down to fit perfectly. The pins are pressed in by power press, eliminating all danger of them pulling out.

The adjuster is manufactured by the Nattanch and Strong Company, 207 Sixth Avenue, Des Moines, Iowa.

## BEARING AND RACE ATTACHMENT

THE Greb Company, Inc., 172 State Street, Boston, Mass., are manufacturing a new attachment for the No. 2 Greb Grip Puller. This attachment has a knife edge and can be forced behind the magneto, electrical generator and self starter bearings where it is impossible for an ordinary puller to be attached. It will pull bearings and races up to and including two inches.



# A Selling Point That Sells

Kopper King Spark Plugs are anti-fouling and rustproof. This is a selling feature that really appeals to the car owner. A Kopper King Plug will not rust into the cylinder head.

This enables you to sell your customers a Spark Plug that ensures freedom from trouble.

The Kopper King is a sales-builder—once a car owner buys his first one, he will, in future, enthusiastically specify Kopper King Spark Plugs throughout.



Rust-proof

A heavy coating of copper protects the body of the plug. This prevents carbon deposits; carbon under electrical heat will not adhere to copper.

## KOPPER KING

Kopper King Spark Plugs ensure you a better margin of profit than any competing plug. They meet every requirement. Once sold, they stay sold.

*"Tested for Service"*

### Canadian General Electric Company, Ltd.

Head Office - TORONTO

Branch Offices: Montreal, Sherbrooke, Quebec, Halifax, Sydney, St. John, Ottawa, Hamilton, London, Windsor, Cobalt, South Porcupine, Winnipeg, Calgary, Edmonton, Nelson, Vancouver and Victoria.



**TRI-CO FRICTION JOINT MIRROR**

THIS is a flexible mirror bracket which, the makers say, may be instantly set at any desired angle with a touch of the hand. It is fitted with a self adjusting friction joint allowing the free manipulation of the glass from various angles, at the same time holding its position against the action of any vibration. The mirror is beveled French plate, size 7x2½ inches. This mirror is suitable for adjustment to any enclosed car, fitting snugly against the top or brought down for service to command a clear and complete view of the entire roadway at the rear. Also made with windshield clamp for attachment to the open cars. May be instantly shifted so as to allow either driver or passenger to have command of the roadway at the rear.

It is made by the Tri-Continental Corporation Mfgs., Buffalo, N.Y.

**EX-L RADIATOR**

THIS radiator is for Ford trucks and fits all models 1917 to 1920. It has cast-iron tanks and frame, oval brass tubes and is mounted on heavy springs which, the makers say, protect the radiator from road shocks. Car can be run for long distances without refilling radiator. The radiator is designed to withstand the effects of freezing. It is made by the Auto Radiator Manufacturing Co., 1712-1714 South Michigan Avenue, Chicago.

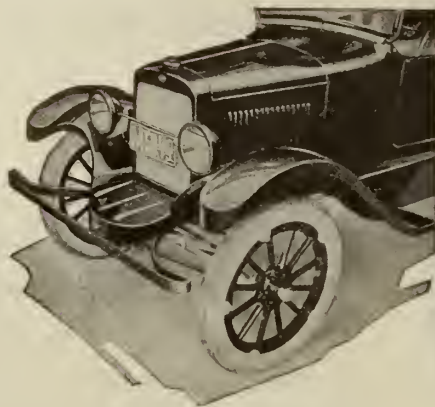

Wayne Bumper.

**HYRATE CADMO VOLT READER**

THE Hyrate Cadmo Volt Reader is a high grade voltmeter with combination handle and base, designed for many uses in connection with storage battery work. The principal uses are:

Voltage test of cells on charge or discharge. Cadmium test to determine accurately the state of charge of either or both groups of positive and negative plates. Polarity test to insure proper assembly and direction of charging current.

A cadmium test of a storage battery is the only method of determining which group of plates fails to give capacity or to become charged, and will locate defects such as lack of porosity in the active material not evidenced by inspecting the plates.

The Hyrate Cadmo Volt Reader is most convenient to handle and is entirely self-contained. The instrument itself has two reading scales, one for cadmium and another for voltage. The stationary contact spike, the supporting clip as well as the flexible conductors, cadmium and conductor contact points, are integral with the instrument but can be easily renewed when necessary. It is manufactured by the Service Station Supply Co., Detroit.

**CRANK-PIN RE-TURNING TOOL**

THE Weber crank-pin re-turning tool is designed for trueing up worn crank shaft pins. In using the Weber, the crank shaft is placed between centres on the lathe; the tool is clamped on the pins to be turned and rides around with the pins. The handle rests against the ways of the lathe. It is not necessary, the makers say, to offset the crank shaft. The cutter is a forming tool the full width of the pin to be turned. This cutter is rounded on each end to take the fillets. The pin is firmly held by three supports, one of which is adjustable while the tool is in operation. These supports hold the pin independent of the cutter. The cutter cuts perpendicular and parallel to one of the back supports, and thus generates a round pin. It cuts only on the high spots of the pin and makes the pin perfectly round at the same time, leaving the least possible amount of material. A micrometer dial is placed below the hand wheel which feeds the cutter to enable the operator to gauge the cut and duplicate diameters.

The makers are the Sawyer-Weber Tool Manufacturing Co., Los Angeles, California.

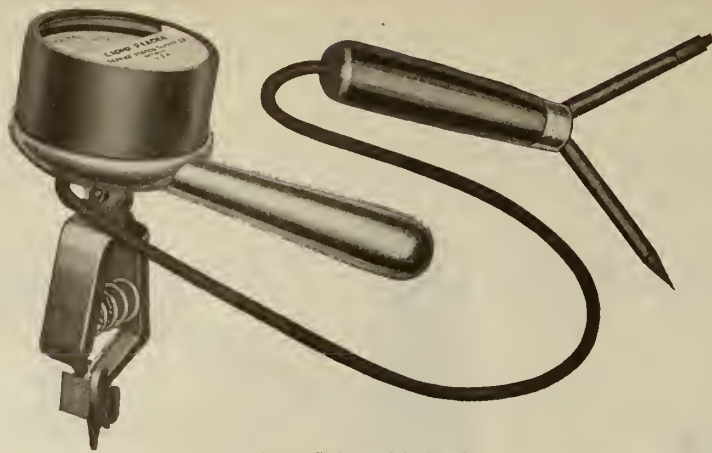

Hyrate Cadmo Volt Reader

**CLARK TURNER PISTON**

THE Clark-Turner De Luxe grey iron piston is a highly developed form of piston, extremely light in weight. The interior of the piston is ribbed with a great number of small reinforcing bands, thus producing a strong piston which is yet light in weight. It is furnished for all makes of automobiles, trucks and tractors and is manufactured by the Clark-Turner Piston Company, 1246 South, Los Angeles St., Los Angeles. Canadian distributors are the Precision Machine Co., Calgary, Alberta, Bowman Brothers, Limited, Regina, Sask., Duplessis, Bezier & Valiquet, Montreal, Plewes, Limited and Sterling Engine Works, Winnipeg.

**FORDSON FENDERS**

THESE fenders, made by the Moore Manufacturing Co., Waterloo, Iowa, are for the Fordson tractor. The construction is very durable. The braces are made of heavy material to withstand vibration. The bracing does not interfere with the driver getting on or out. The fender is made of No. 20 gauge steel and reinforced with 1-in. T-iron.

**THE HOOFF FORD TRANSMISSION TOOL**

THE Hoof Tool Co., 522 Boston Block, Minneapolis, Minn., are offering a new tool which they claim saves half to two-thirds of the time usually consumed in changing Ford transmission and brake lining.

It is constructed of high-grade steel castings, black japanned, with spring clevis of specially tempered wire guaranteed to hold its shape against the pressure of the bands.

It is designed to do away with the old troublesome method of assembling and changing transmission linings and that its use in repair shops and garages saves the time of high-priced men, enables them to accomplish more by giving them a tool that will do away with the disposition of wrecking part of the job.

**DUFF AUTOMOBILE JACK**

THE Duff Mfg. Co., Pittsburgh, Pa., are offering a new universal auto jack No. 411 for which they claim special features. It has a handle twice as long as the ordinary one, making it easy to operate with increased leverage and avoiding soiled clothing. When not in use handle uncouples to half its length. The jack is said to operate with a long or short stroke as desired and with handle inclined at any angle, making it specially suitable for cars with gasoline tank or other obstructions in rear.

The range of adjustment possible is from 4 to 18 inches and capacity 1 1/2 tons.

**THE WAYNE BUMPER**

THE Wayne Bumper Co., Fort Wayne, Indiana, is manufacturing and distributing a new bumper which has been endorsed by the Willys-Overland Co. as the best spring bar bumper for the Overland "4."

The makers claim that it is strong and durable, looks neat and is easily attached in six minutes without removing any part of car or drilling of holes. All the attachments, including bolts, brass, etc., are covered by the pan covering the springs, giving the bumper the appearance of an original part of the car.

**BATTERY TESTING VOLTMETER**

THE Weston Model 443 battery testing voltmeter is a new device placed on the market by the Weston Electrical Instrument Company, Newark, New Jersey, for meeting practically every requirement of the battery service station. A fuller description of this device is found on page 18.

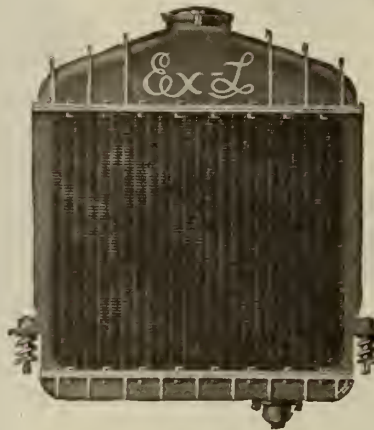

Ex-L Radiator.



Tri-Co Mirror.



De Luxe Piston.

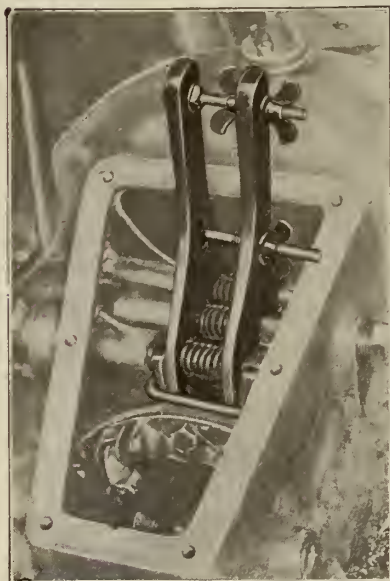

Hoof Ford Transmission Tool.



Weston Voltmeter.



Crank-pin Tool.

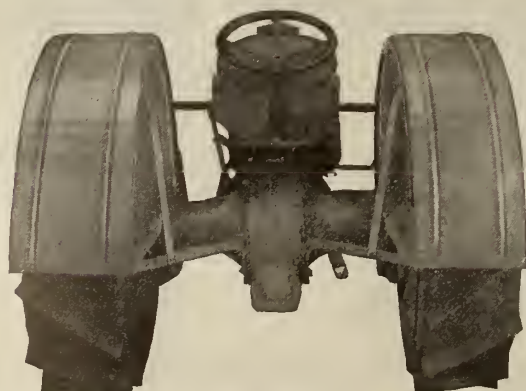

Fender for Fordson Tractor.

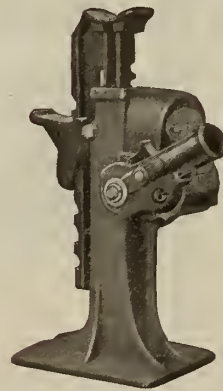

Duff Auto Jack.



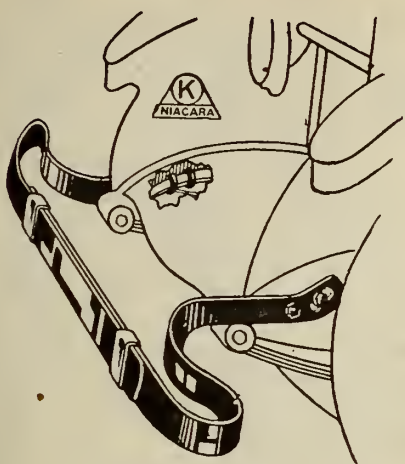

The style illustrated with patented "Hookbolt" attachment fits 90% standard cars. Special style Lyon Bumpers for all other cars.

Write for illustrated Bumper catalog

# On Slippery Pavement

Drivers have less control of their cars when pavements are slippery from water, snow and ice, and are more liable to damage their cars, or to have them damaged by other drivers.

If owners appreciated the protection afforded by

## PATENTED RESILIENT Lyon Bumpers

you would have less difficulty in selling this equipment to men who have been driving cars without it in the past.

We would suggest pushing Lyon Bumpers during the fall season when sales are comparatively quiet.

For sale by dealers and jobbers throughout Canada.

Sole manufacturers under Lyon Canadian Patent.

### Kinzinger, Bruce & Co., Limited

NIAGARA FALLS, ONTARIO

You're Interested Most in How They Sell—

# "HEXALL"

Trade Mark Reg. U. S. Pat. Office

## Socket Wrenches

FROM the moment a "HEXALL" passes the lynx eyes of our factory inspectors as "standard"—all along the line—from shipper to jobber, to dealer, to ultimate consumer, it is accepted at its face value without question. WHY?

Because they know, from experience, that the makers themselves know that "HEXALL" Socket Wrenches are mechanically-perfect, durable, dependable, built to withstand every-day usage. That, to bind their promise of performance, they guarantee every "HEXALL":—

**"Break any Sedgley Wrench and We Repair it—No Charge"**

There you have the story—why "HEXALL" is such a tremendous seller; why sales are growing by leaps and bounds. There are seven sets—a "HEXALL" for every need.

Write for prices and discounts. Dealers reach your jobbers; jobbers reach us.

**R. F. SEDGLEY, Inc. Est. 1897**

2311-13-15 North 16th St., PHILADELPHIA, PA.

Canadian Distributors: Lamontagne, Limited, Montreal, Canada.

Harold F. Watson Co., Sole Agent: 208 Coristine Bldg., Montreal, Canada.

**NOTE:** Can you imagine anyone passing by an attractive counter, case, or window display of the "BABY" without wanting one? Think it over!

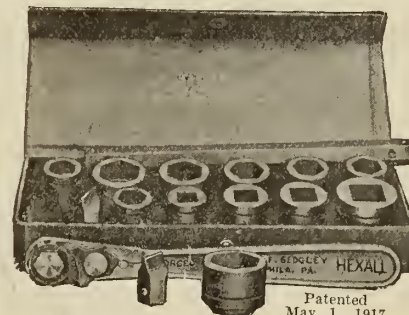

"HEXALL" Ratchet Socket Wrench No. 1—16 pcs.

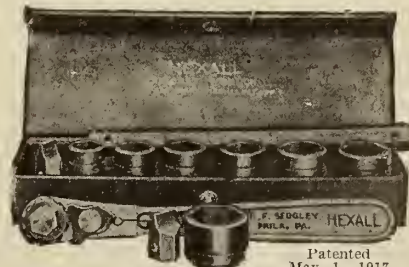

"HEXALL" Ratchet Socket Wrench No. 2—11 pcs.

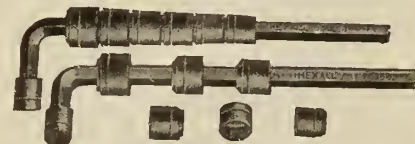

Patented Dec. 31, 1918  
"HEXALL" Socket Wrench No. 5—8 pcs.

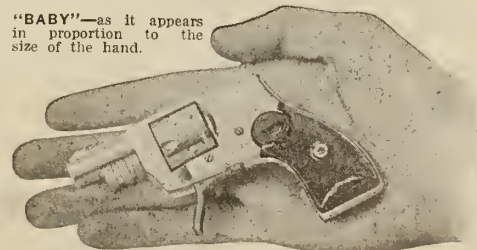

"BABY"—as it appears in proportion to the size of the hand.



**AUTO PRESS M K NO. P-2**

THE Auto Press M K No. P-2 was designed particularly for work in the garage and automobile repair shop. It is so built, the makers say, that it embodies the idea of a number of men who have had years of experience in repair shops and will do the great variety of work that is required there of a press in the quickest time. The frame of the press is made of a special steel casting. The ten-inch hand wheel at the top is used for bringing the screw down on the work for light pressure and a 3-4-inch rod passed through an eye in the head will exert sufficient pressure to bend 2 1-2-inch stock. The screw is made of special alloy steel, the square thread running four to the inch and is capped by a notched swivel nut turning on a bronze bearing plate. Where the screw passes through the frame of the press it turns on a nut which is entirely separate from the frame and can be renewed if necessary.

The "V" blocks on which the work rests when being straightened are movable and slide to and from the screw; tongues running in the grooves keep them centered with the screw at all times. Below the screw is a 7-inch plate which has four slots, the openings being 3-4-in., 1-in., 1/2-in. and 2 1-2-in. This gives quick adjustment for any shaft when pressing off gears.

The testing attachment is supported by two heavy brackets and can be put into place or removed very quickly. It is only necessary to turn one set screw on each bracket to do this. The shaft passing through these brackets is 1 7-16 inches in diameter and is movable and has a slot throughout its length in which the guides of the center supports travel. This slot keeps the center lined up when their supporting arms are moved back and forth on the shaft.

The press is powerful and can easily be moved where required. Its base is 10x17 1-2 and has four holes by which it may be bolted down. The height between the plate and the swivel is 12 1-4 inches and between the face on which the bevel blocks rest, 13 3-4 inches. It will press off gears up to 12 inches in diameter, and straighten stock up to 2 1/2 inches in diameter. Any length of bar can be straightened under this press and special work can be done by replacing the metal blocks with wood or iron blocks of various shapes. It can be used for straightening axles, pressing on and off gears, straightening bent crank shafts, straightening parts sprung in tempering, etc., etc.

It is made by the Columbia Mfg. Co., of Belleville, Illinois.

**MOSPICO CASTER SPINDLE**

THE Mospico caster trailing spindle is a new offset front axle spindle for Ford cars. The makers say it works on the same principle as the casters on a chair and prevents side thrust and skidding. It is designed to make steering easier and to enable the driver to drive through sand and mud with the same ease as on smooth roads. They are strongly made and can be installed in less than 45 minutes. They are made by the Motor Spindle Corporation, 214 East Jefferson, Detroit, Mich.

**CONNECTING ROD ALIGNMENT MACHINES**

THESE machines are designed for straightening and lining up automobile connecting rods. One is adjustable and one solid. The arbor pins are intended for Ford connecting rods and bushings are used for the different sizes of crank shafts. Special pins can be furnished for any type of rod. All plates, bushings and pins are hardened and ground. The makers furnish with these machines the sleeve for the Fordson tractor crank shaft size. Both machines are manufactured by the Carswell-Hammond Mfg. Co., Boone, Iowa.

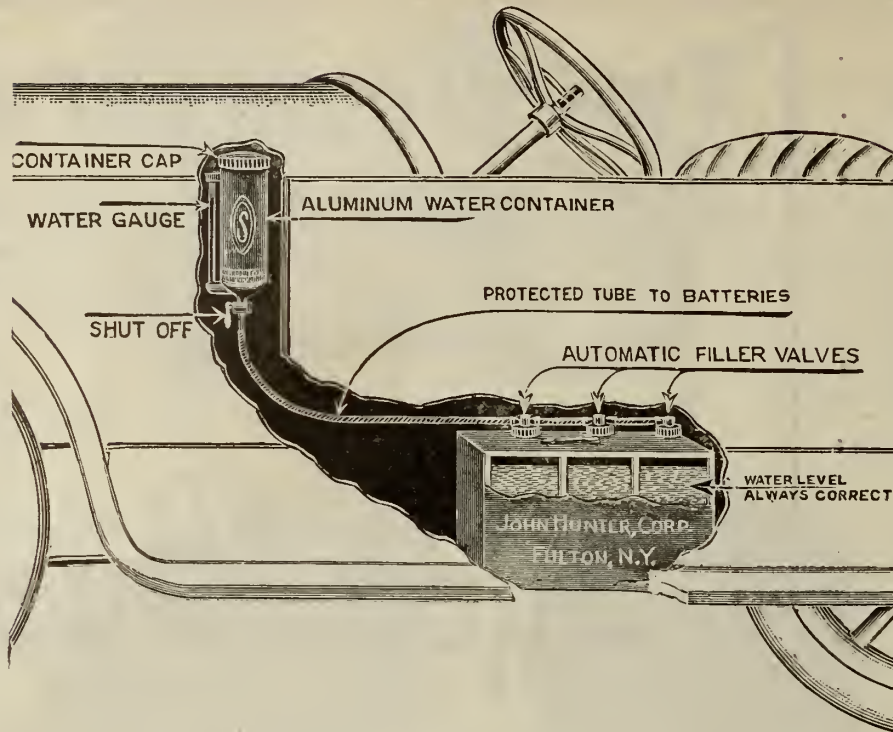

Automatic Battery Water Filler.



Alignment Machine

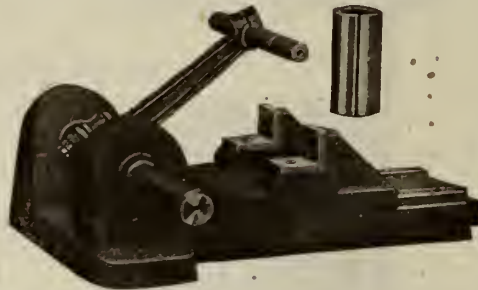

Adjustable Alignment Machine



Klinch-Linx



Mospico Caster Spindle

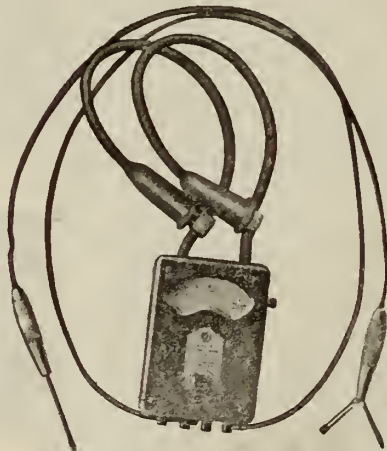

Hydrate Trouble Detector

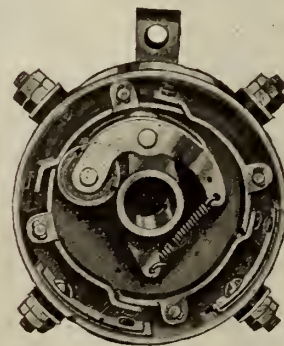

PATENT APPL'D. FOR. Duplex Timer



Auto Press M.K. No. P-2

**AUTOMATIC BATTERY WATER FILLER**

THIS device is for automatically supplying a battery with the proper quantity of water. It consists of an aluminum container, a piece of rubber tubing encased in flexible metal tubing, and automatic valves attached to the regular vent caps. It is easily installed; all that is required, the makers say, is to attach the aluminum container to the dash of the car and replace the battery vent caps with filler caps, attach metal covered hose to end cap nearest the dash and cut small hose to required length and attach from cap to cap. When the container is filled with distilled water and the cap turned on an equal distribution of water is fed to each battery automatically. The electrolyte is kept at the same level no matter how the water may evaporate.

It is manufactured by the John Hunter Corp., Fulton, N.Y.

**HYDRATE ELECTRO TROUBLE DETECTOR**

THE Service Station Supply Co., of 30 East Larned Street, Detroit, Mich., has developed a combination instrument for detecting troubles in the electrical apparatus of any make of automobile, known as the Hydrate Electric Trouble Detector. It combines five instruments in one, the makers state, and is so designed that a series of simple tests, readily made and requiring no special electrical training, will enable anyone with this instrument to discover the cause of any defect or failure in the generator, starting motor, lights, horn, switches, wiring, battery or ignition apparatus. It is a combined voltmeter and ammeter, with 3 voltage and 2 ampere scales for accurately testing any electrical pressure or current found in automobile equipment. Leads, prods, clips, and a Cadmium test electrode, are furnished with the detector.

**DICKINSON MUD LUG**

THE "Dickinson" emergency mud lug for autos has many interesting features, the makers say. By clamping a lug on each rear wheel when becoming stalled in mud or sand, the motorist is out and on his way without delay. It can be attached or detached very quickly; it can be instantly adjusted to fit any rim; it will not mar the paint or injure spokes or rims, one pair of lugs can be carried in a space 8 by 6 inches and 4 inches deep. The lug is manufactured by the Liberty Manufacturing Company, of Chicago Heights, Ill., U.S.A., who contemplate establishing a factory in Ontario for manufacture and distribution over Canadian territory.

**KLINCH-LINX**

KLINCH-LINX, manufactured by the American Auto Products Co., 1319 L Street, N.W., Washington, D.C., are designed to replace broken side links of tire chains. They simply slip into place and are clinched with a hammer or pair of pliers. The makers say they can be used in an emergency to temporarily replace broken chain hooks.

**THE DUPLEX TIMER**

THE Franco-British Supply Co., of Winnipeg, Man., are marketing a timer which the makers claim combines the accurate firing of the roller type and the superior contact of the magnet and gives user a double duty timer. The Duplex Timer consists of a case made of solid stamped, cold-rolled steel, eliminating internal condensation of moisture.

The only revolving part in the Duplex is a double row enclosed type roller which the makers claim has sufficient lubrication, avoiding the necessity of oiling the timer.



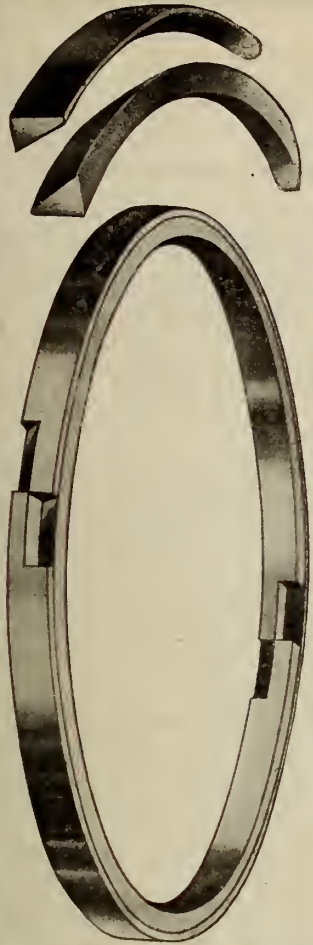

## A Perfectly Sealed Firing Chamber

There can be no lost power where Excellence Two-Piece Piston Rings are used. They seal tight—absolutely.

Examine an Excellence Ring and you will be at once struck with the simple and positive action. The two pieces are so fitted together that they will readily contract or expand as necessary, **but will always be tight.** No gas, oil or compression can pass, all power must be exerted on the piston head.

These sizes of Excellence Rings are now available: 3 3/4 x 1/4, 3 3/4 x 3-16 and 3 11-16 x 3-16. Other sizes will be ready soon.

Manufactured exclusively and distributed by

**EXCELLENCE**  
TWO-PIECE  
**PISTON RINGS**

**Lamontagne Limited**

Wholesale Dealers in Automotive Equipment

Quebec Montreal Winnipeg

*The Only Perfect Piston Ring*

## A 24-Hour Radiator Repair Service



Why fuss with troublesome radiator repairs? They can be more cheaply and effectively executed by the manufacturer.

Ship any make to our Repair Department and in 24 hours, or less, it will be on its way back to you—freight or express as you instruct.

We promise you no wait service and A No. 1 workmanship.

**McCORD MFG. CO.**  
WALKERVILLE, ONTARIO



Tool Locked in Position  
for Removing or Replacing Tire  
**K.P. Universal**  
Rim Tool

The easiest way to remove tires from split rims. Collapses, holds rim collapsed while changing and forces the rim back on tire again with utmost ease.

PRICE \$6.00

Sold by

**Northern Electric**  
Company, Limited

Montreal Ottawa London Regina Edmonton Toronto Winnipeg Calgary Vancouver  
K. P. Products Company, Inc., 250 West 54th St., New York City

# Make Your Fall and Winter Months Prosperous

Every Fall and Winter can be seen renewed efforts on the part of car owners to make motoring an all-year proposition, and this year promises to eclipse all previous years for Winter driving. Auto owners will, therefore, look to dealers for service. Turn your garage or store into a local Automotive Equipment Service Station by selling the Hyslop line of Winter Equipment and Necessities.

Dealers who SELL THE HYSLOP LINE ARE SURE TO GET THE BULK OF FALL and Winter Business because it comprises the largest and most complete stock of Winter Equipment and Necessities designed to cater to warmth, comfort and safety during the cold weather months.

A well-balanced stock of seasonable cold weather Equipment will make your Winter months prosperous ones.

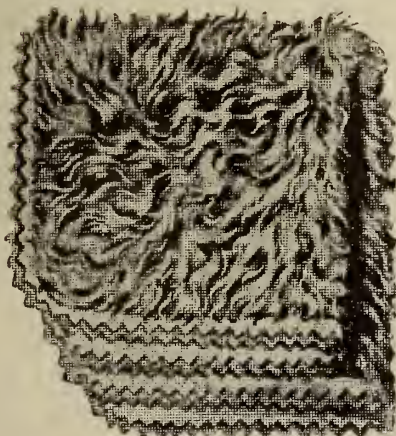

## Fur Motor Robes

	Price
No. 6190—Gray Goat, 70 x 60 in. ....	\$30.00
No. 6191—Brown Dyed Goat, 70 x 60 in. ....	42.00
No. 6192—Black Dyed Goat, 70 x 60 in. ....	42.00

## Heavy Quilted Fan Front Engine Hood Covers

The FAN FRONT is the latest and most popular type of Engine Hood Cover. It is simple and as easy to open and close as a lady's fan. You do not even have to remove your gloves; simply pull the handle. The convenience alone is well worth twice the additional cost. Hundreds of well-satisfied users have told us how well they liked them, and you simply cannot afford to take chances without the protection they can give you.

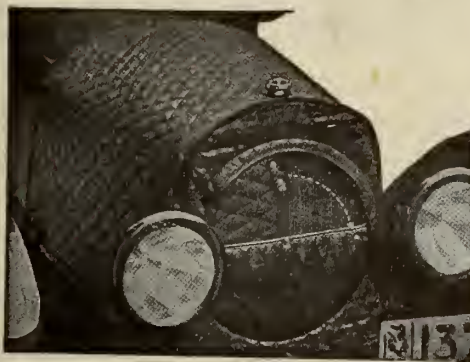

Made from extra choice materials, they add to the appearance of the car.

No.	Model	Price
No. 6202	Ford 1917-20	\$15.00
No. 6203	Chevrolet 490	16.00
No. 6204	Gray-Dort	18.00
No. 6205	Maxwell	20.00
No. 6206	Dodge	20.00
No. 6207	McLaughlin D-35	20.00
No. 6208	Overland, 4-cyl. model	22.00
No. 6209	Studebaker, 4-cyl. model	26.00
No. 6210	McLaughlin, 4-cyl. model	27.00
No. 6211	Geo., 4-cyl. model	28.00
No. 6212	Cadillac, 4-cyl. model	27.00
No. 6213	Chalmers and other 4-cyl. models	28.00
No. 6215	McLaughlin, Studebaker, Chalmers, Geo., Hudson, Chandler, Packard, Wolseley and other 6-cyl. models	\$28.00
No. 6214	Chevrolet Baby Grand	28.00
No. 6216	Cadillac, Peerless, Cole and other 8-cyl. models	28.00
No. 6217	Packard, Pathfinder and other 12-cyl. models	30.00

Fabric leather or silk mohair in special colors to match color of car, extra...\$5.00

## The Utility Protected Heater

The Ornamental Foot Rail which Radiates Heat.



Utilizes the heat from the exhaust. Equipped with valve for turning the heat on or off.

No.	Model	Price
No. 6193	Utility Protected Heater	\$33.00
No. 6194	Utility Front Seat Heater	20.60
No. 6195	Utility Junior Heater	14.85

The above items represent a few of the hundreds of live Winter Necessities which we have in stock. Consult your Hyslop catalogue for further information and prices.

**HYSLOP BROTHERS, LIMITED, SHUTER AND VICTORIA STREETS, TORONTO**





# PERFEX

## The Perfect Radiator

Perflex radiators for Fords are a quality product embodying features that cannot be had in other radiators.

A patented spring bracket suspension and a real radiator core of great efficiency.

*The last word in Radiator construction*

Perflex Radiator Co., Racine, Wisconsin, U.S.A.

P. A. C. McINTYRE & COMPANY  
311 Confederation Life Building, Winnipeg  
Direct Representatives for  
Manitoba, Saskatchewan, Alberta and British Columbia

## Ten Points That Sell Kales "Hindview" Auto Mirrors

- 1—The Auto Mirror is an effective and inexpensive form of accident insurance. It prevents numerous rear-end and side collisions.
- 2—The driver whose car is equipped with a Kales "Hindview" can keep his eyes on the road at all times. He is never forced to twist around in his seat to view the rear traffic when he wishes to slow down or turn out.
- 3—The Kales "Hindview" gives an accurate reflection. Every glass is as perfect as possible to obtain.
- 4—The mirror is round, as is the ball of your eye, focussing entirely upon the traffic behind. It shows no unnecessary part of the rear of your car.
- 5—No water can get to the rear surface of the mirror, causing the silver to curl or spot. The brass back is waterproof; it is of one piece, turned over the beveled edge of the glass.
- 6—Each part is substantially made and put together. Mirror and frame cannot come apart.
- 7—All parts are rust-proof and enameled.
- 8—Mirror is immediately adjustable from the driver's seat. It is unnecessary to use a tool, or even turn a thumb-nut, to change the adjustment.
- 9—Clamps are large and firm. No vibration can affect the position of the mirror.
- 10—The practicability of the auto mirror as a factor of safety in driving is best proven by the fact that laws of the Province of Ontario now require the installation of mirrors on all Motor Trucks.

A style for every car and truck.

**KALES STAMPING CO., LTD.**

61 Walker Road  
Walkerville, Ont.



Makers of  
Pressed Metal  
Parts, Washers,  
Clips, Shims,  
Card Holders,  
etc.

## NEWS — OF THE TRADE FOR THE TRADE

### ONTARIO

**BROCKVILLE.**—Brockville reverted to standard time on September 5.

**COLLINGWOOD.** — The Imperial Steel and Wire Company have begun excavating for their new factory.

**BROCKVILLE.**—The Briscoe Motor Co., Ltd., has moved its head offices from Toronto to the factory here.

**LONDON.** — The London Concrete Machinery Co. has prepared plans for a \$100,000 addition to the present plant.

**HAMILTON.**—The A. McKim advertising agency has opened a branch office in Hamilton.

**BARRIE.** — Messrs. Ferguson and Owens opened a new garage here recently.

**CHATHAM.**—Messrs. Warren and Hay have purchased the Rankin Garage from Messrs. Porter and Miller.

**NEWMARKET.**—J. E. Nesbitt, implement dealer, was a visitor at the Toronto exhibition.

**HAMILTON.**—The city has purchased a 1,200-gallon motor driven street flusher from the Tiffan Company.

**AGINCOURT.**—Delos Reesor, tractor and implement dealer here, assisted at the J. I. Case Threshing Machine Company exhibit at the C.N.E.

**TORONTO.** — The incorporation is announced of the Universal Gas and Oil Limited, with a capital stock of \$1,500,000.

**TORONTO.**—The Cellular Pneumatic Tire and Rubber Company of Canada, Limited, has been incorporated with authorized capital of \$250,000.

**HAMILTON.**—The officials of the Sawyer-Massey Company say they have secured a contract for all their output for the next three years.

**CHATHAM.**—Robert Gray, president of the Gray-Dort Automobile Co., has been elected a director of the Standard Bank of Canada.

**GUELPH.**—The Shinn Mfg. Co., of Canada, manufacturers of Shinn flat lightning rods, will enlarge their plant this fall.

**WALKERVILLE.**—The Fisher Body Co., manufacturers of motor car bodies, are erecting a new factory to cost \$175,000.

**WHITBY.**—The town of Whitby is negotiating with the Mauson Motor Company for the location of a plant by that company in the municipality.

**SUDBURY.**—The proprietors of the McLeod Garage are doing a big business in autos, tractors and accessories. They keep two tractors in stock for demonstration purposes.

**KITCHENER.**—A spark from an engine operating a corn cutting machine caused a fire which destroyed the barn and adjoining buildings of Allen Brubacher near here.

**KITCHENER.** — Lincoln Kuehner, foreman at the Dominion Tire plant, died suddenly in a dental chair here recently, while he was being prepared for the operation of having his teeth extracted.

**TORONTO.**—J. A. Goudy, of Hyslop Bros., Ltd., Cadillac distributors, has attended every motor show held in conjunction with the Canadian National Exhibition. He claims to have sold more Cadillacs than any other Canadian salesman.

**CHATHAM.**—Local implement dealers report a boom in the sale of farm implements. An unprecedented rush is reported for corn harvesters, corn binders and silo filling machines.

**BELLEVILLE.**—The Belleville Vulcanizing Company have enjoyed a big business during the past year. They are equipped for every kind of tire repair and service.

**WATFORD.** — The Andrews Wire Works of Canada, Ltd., is enlarging its plant here. The new addition will give 75,000 square feet of increased floor space.

**BRIGHTON.**—Fred Wright, proprietor of Wright's Garage, has taken into partnership J. C. Harry, of Belleville. Henceforth the firm name will be Brighton Garage.

**PETERBORO.** — The Laundryette Manufacturing Company, of Cleveland, Ohio, are opening a branch factory here for the manufacture of their patented domestic laundry machine, which both washes and dries clothes.

**OWEN SOUND.**—Mr. Armstrong, the new manager of the Northern Bolt, Screw and Wire Co., recently took over his duties in succession to W. L. Nelson, who resigned to go to Detroit.

**TORONTO.**—The Dominion Automobile Co., Bay Street, has purchased property 90 x 50 feet at the southeast corner of Yonge and Isabella Streets, to be used for the erection of sales rooms.

**TORONTO.**—A jury in the County Court awarded the Russell Hardware Co. \$325 in the action against Abe Brown, of Woodstock, for \$700 for the damage done to their truck in a collision on the Toronto-Hamilton highway last May.

**TORONTO.** — The Wilkinson Plow Works have sold part of their land to the Willard Storage Battery Company for \$70,000. The purchasers intend to start at once on the erection of the first unit of a series of buildings for the manufacture of storage batteries.

**LONDON.**—The Chamber of Commerce has concluded arrangements whereby the Service Motor Truck Company, of Wabash, Ind., will open a branch factory in this city. The plant will cost about \$500,000. The Ruggles Motor Company, of Alma, Mich., has also decided to locate here.

**NEW TORONTO.** — The Lion Tire and Rubber Company, Ltd., recently incorporated, propose to erect a plant here, on the Toronto-Hamilton highway. The new factory will be thoroughly up-to-date and equipped for the manufacture of fabric and cord rubber tires, as well as a line of inner tubes for all kinds of motor vehicles.

**ST. THOMAS.**—W. Powers and Mrs. A. Pettit, local residents, were severely injured recently near this city when the car in which they were riding overturned in a ditch. The accident is alleged to have been caused by the glaring headlights of a large American car which blinded the driver of the auto in which the injured persons were riding.

### QUEBEC

**MONTREAL.**—The Downtown Garage, Limited, has been incorporated with a capital stock of \$100,000.

**MONTREAL.**—The Ford Motor Company will establish shortly a new five-million-dollar factory near Dominion Park.



**CHAMPION SPARK PLUG CONVENTION**

THE eighth annual sales convention of the Champion Spark Plug Co. was held at Toledo, Ohio, July 19th to 31st, and was a most enthusiastic gathering. The number totaled over 150 men, who make up the sales force in Canada and the United States. The territory represented was from Edmonton to Key West, Fla., and from Newfoundland to San Francisco. This convention covered two weeks and the program contained many innovations. The first week was given up entirely to business, and the second week almost wholly to festivities, except for round table discussions and general "gingering up" talks.

One of the pleasant incidents of the convention was the arrival of F. B. Caswell, vice-president and general manager of the Canadian plant, and the general director of sales, who reached the plant at Windsor, Ont., just in advance of the visit of inspection of the entire convention, and the men certainly gave him a rousing welcome.

One of the days of the convention included an educational trip through the Champion insulator factory—the Jeffrey-Dewitt plant in Detroit—where the men saw the clay arrive and followed the processes of construction through each stage. A special train carried the men to and from Detroit and a fleet of 35 Columbia cars took care of the visitors during the day. Luncheon and dinner were served at the Detroit Athletic Club.

The sales force in Canada is ever increasing. Lately there has been added to the force D. S. Pocock, for the Province of Manitoba; D. J. Dowling, for Saskatchewan, and W. T. Dodds, for Alberta and British Columbia.

**BEATTY BROS. SUMMER SALES CONVENTION**

THE Ontario Salesmen of Beatty Bros., Ltd., met together recently in a three-day whirlwind Sales Convention. This company's new business year commenced Sept. 1st and during the convention plans were made and quotas set for the forthcoming year. The year of 1919-20 was a most successful one and there is every prospect for still greater things next year. An interesting feature was the visit of the wives of the salesmen who were invited to come with their husbands. The head office thus had the pleasure of meeting practically all the "better halves" of their Ontario men. As well as being profitable in a business way the convention was a splendid "get together" meeting and a pleasurable time as well.

**MOTOR TRUCK AS TRACTOR**

THE motor truck is constantly proving its versatility and adaptability to all kinds of work on the farm, says the Scientific American. Not only is its usefulness increasing for delivery work on and about the farm but it has also demonstrated that it can work in uncultivated fields in case of an emergency. This is the discovery of William Berkenstock, of Fullerton, California, who used a three-ton, four-wheel-drive truck to disk and sub-soil a ten-acre orchard, in which he was preparing to plant young citrus trees. When his tractor broke down and he was confronted with the task of disk the field before the trees arrived he hooked the disk onto the truck and dragged the entire tract with ease. While this is unusual work for a truck it demonstrates, nevertheless, its versatility and power in emergency cases and also brought out the tractive power of the four-wheel-drive principle in an unmistakable manner.

**GOES TO ENGLAND**

THE British Government Trade Commissioner in Ontario, F. W. Field, will leave Toronto on the 8th October on an official visit to the United Kingdom to confer with the Department of Overseas Trade, London, Chambers of Commerce and manufacturers and merchants throughout the British Isles. He will be overseas three months or more.

# Northern Electric POWER and LIGHT

*A Complete Line of  
Electric Farm Plants  
and Accessories*

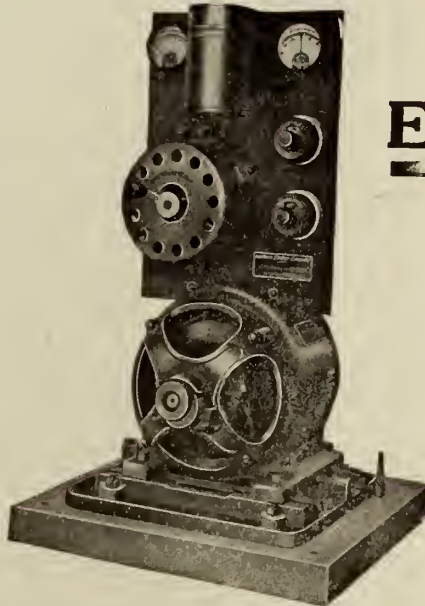

Belt-Connected Plant — operates from any good engine

- Belt-Connected Plants
- Direct-Connected Plants
- Water Systems
- Portable Motors
- Farm Accessories
- Wires and Supplies

This line will make you the Electrical Headquarters of your District.

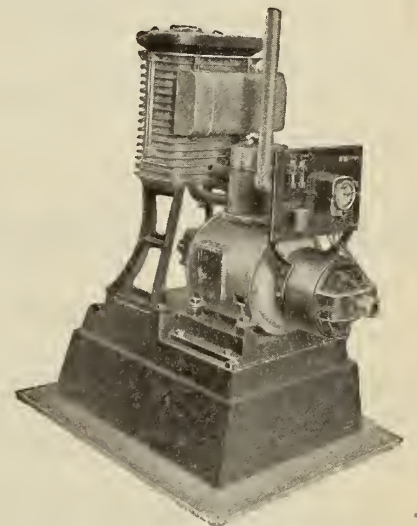

Direct-Connected Utility Plant  
¾ K.W.—32 Volt

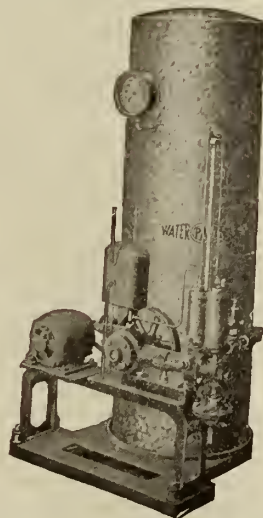

Automatic Water System, showing Tank, Pump and Motor. Capacities 100 to 1,400 gals. per hour

With the plant you can usually sell a Water System, while limitless follow-up sales possibilities are yours with Utility Motors, Electric Churns, Vacuum Cleaners, Washing Machines, Dishwashers, Irons, Toasters, Percolators, Wiring Devices of all kinds, Fixtures, etc.

Write Our Nearest House Now

Be the Farm Electrifier of Your District

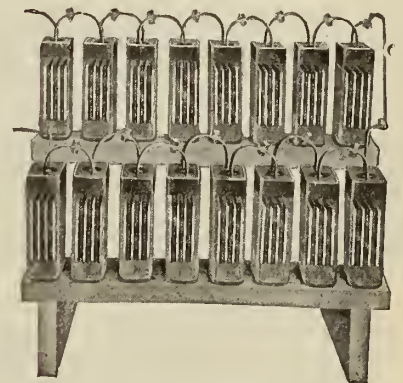

Titan Storage Battery, 16 cells supplied with each plant. 110 or 200 Ampere Hours.

## Northern Electric Company

LIMITED

MONTREAL    OTTAWA    LONDON    WINNIPEG    EDMONTON    VANCOUVER  
HALIFAX    TORONTO    QUEBEC    REGINA    CALGARY



### AUTOMOBILE SPRINGS

The Guelph Spring and Axle Co.

Guelph - Ontario  
Manufacture

AUTO SPRINGS  
ALL KINDS  
HIGHEST QUALITY

### Keeping Tab on Conditions

During the unsettled conditions of to-day it is necessary to watch the markets and the trade news very carefully. An order for Press Clippings will bring to your desk each day the particular news you want, culled from the newspapers of Canada. You are kept posted right up to the minute and there is no better time than the present to make use of our service.

SUBSCRIBE TO-DAY

Canadian Press Clipping Service

43-153 University Ave., Toronto



# How About Your Pet Investment?

WHAT did the recent sharp decline mean as regards that stock in which you have money invested? Are you a little perplexed, perhaps a little worried?

THERE are facts you should know—facts regarding the influence general business conditions will have on profits. Perhaps there is some intimate information regarding the company unknown to you.

## What Are You Going To Do About It?

WHY not do the obvious thing—ask about the stock? Ask someone who knows, or who can find out. Ask the editor of THE FINANCIAL POST.

EVERY week THE FINANCIAL POST prints scores of facts bearing on stocks, bonds and other investments. But it is impossible to deal with every security. If you want special information on something, write the editor. You will get a reply which will help you with your investment problem.

REMEMBER, this is an additional service THE POST offers every subscriber.

If you aren't already a subscriber hadn't you better take steps to become one at once? Fill in the coupon below and mail to us with any inquiry you may want to make. Remember there's no limit to the number of inquiries.

## THE FINANCIAL POST

The Canadian Newspaper for Business Men and Investors

143-153 UNIVERSITY AVE., TORONTO

\$5.00 May Make or Save You \$500.00 or \$5,000.00

Annual Subscription \$5.00.  
THE FINANCIAL POST,  
143-153 University Ave., Toronto.

Please enter me a regular subscriber, commencing at once. I forward \$5.00 to pay for my subscription for the first year.

Name .....

Address .....  
Please write plainly

### PREMIER ON UNIFORM CONTRACTS

THE following communication was received from Premier Martin, of the Province of Saskatchewan, by the Saskatchewan R.M.A., relative to the resolution passed by the Implement Trade Section at their annual Convention held in June, asking that the Government enact legislation which would make uniform the contracts between the dealers and the manufacturers and the purchasers and the dealers:

"I have your letter of the 28th of June enclosing a copy of a resolution passed at the Annual Convention of the Retail Merchants' Association with regard to the implement trade. I am having the resolution given every consideration but I would point out to you that, on account of the fact that the manufacturers are located outside of the province the enacting of a contract to be effective between the manufacturer and the retailer would be a very difficult problem. However, the subject will be given the most careful consideration.

Yours faithfully,  
(Signed) W. M. MARTIN."

On receiving the above the secretary got in touch with the members of the Provincial Committee of the Implement Trade Section, notifying them of the contents of the letter and asking for suggestions as to the reply to be sent, and the following letter was dispatched to the Premier:

"Dear and Honorable Sir: I have withheld acknowledgment of receipt of your letter of July 12th relative to the resolution passed at the Annual Convention of the Association regarding the inaugurating of a uniform contract, as I wished to bring the contents of your letter before the Provincial Committee of the Implement and Auto Trade Sections, in order to obtain their ideas as to that part of your letter in which you say that on account of the fact that the manufacturers are located outside the jurisdiction of the Province, the enacting of a contract to be effective between the manufacturers and the retailers would be a very difficult problem.

"I am instructed by the Provincial Committee to point out to you that inasmuch as the Government was able to regulate the dealings of the manufacturers doing business in the province with the public, there should not be very much more, if any, difficulty in controlling their policies with the agents or dealers.

"May I also point out to you that in the past every contract has been one-sided, the dealer not figuring in the matter at all except with his name at the bottom of the contract. I am attaching herewith a contract which is typical of those in use by the various manufacturers of farm machinery, from which you will see in a few moments that the contract does a gross injustice to the retail dealers.

"The Provincial Committee of the Implement and Auto Trade Section of the Association desired me to extend to you their sincere thanks for the consideration which you intimate will be given to this resolution, and in closing I would say that the retail implement dealers of the province only wish to be protected to the same extent as the public are protected under the Farm Implement Act.

"We will be very pleased to hear from you further in this respect at your earliest convenience."

### NEWS OF SASKATCHEWAN DEALERS

THE Provincial Office of the Saskatchewan R.M.A. is making arrangements for the preparation of a contract, which will serve between the retail implement dealers and the manufacturers or wholesalers. P. M. Anderson, K.C., of Regina, has been asked to undertake this work, and while it is a lengthy job, it is hoped before very long to have the contract

in shape so that they may be in a position to present the same to the Provincial Government. It will be remembered that the Implement and Automobile section of this association at the Moose Jaw convention held in June already asked the Government to enact legislation which will make the contract uniform as between the retail dealer and the purchaser, and the dealer and the manufacturer or wholesaler.

"In drawing up this contract," says H. T. Pizzev, secretary of the Implement and Auto Section, "the provisions of the Farm Implement Act must be kept in view, and the finished product must be as fair to one as to the other, if the dealers are to get action from the Government. There is no doubt but that the wholesalers and manufacturers will fight this all the way. By every individual dealer getting behind the Association, we should be able to get it through.

"The moral behind this last statement is organization, for just as organized labor can obtain their demands, so can the implement dealers of the Province obtain what is rightfully theirs as members of a complete and thorough organization."

### VETERANS GET IMPLEMENTS AT REDUCED RATES

THE Soldier Settlement Board has made arrangements with manufacturers of implements, harness, etc., to give soldier settlers the benefit of special and substantial reductions in price. Arrangements have also been made whereby live-stock, particularly horses, will be purchased at lowest possible prices and re-sold to settlers at cost to the Board.

The Livestock Branch of the Dominion Department of Agriculture is assisting the Board in the selection of livestock.

The Board also has been able to secure from the Canadian Lumbermen's Association an arrangement by which soldier settlers will be given very favorable rates on lumber purchases. These rates amount to wholesale prices plus ten per cent. to cover cost of handling. These prices apply to material of stock sizes.

Equipment purchased by the Board for settlers remains the property of the Board till loan obligations are discharged. The sale of livestock, implements or other property of the Board without its consent is a criminal offence.

Settlers requiring further information on stock and equipment should apply to the District Superintendent of the Soldier Settlement Board for pamphlets on implements, livestock and buildings.

### FIRE PREVENTION DAY PROCLAIMED FOR OCT. 9

A ROYAL proclamation has been issued by His Excellency the Governor-General, designating October 9 as Fire Prevention Day throughout the Dominion, according to a Canadian Press Despatch.

### SAYS FARMERS PAYING OFF LOANS BEFORE DUE

REPORTS from rural credit societies throughout the Province of Manitoba show that farmers, due to excellent crops this year, are entering a period of unsurpassed prosperity, according to a Canadian Press despatch. As an indication of a good year, C. Gifford, Supervisor of Rural Credit Societies for the Province, stated today that farmers, in a large number of cases, are repaying loans before they are due. Loans totalling \$1,900,000 have been advanced to Manitoba farmers since January 1 through the Rural Credit Department of the Provincial Government. Of this amount the Provincial Government advanced \$1,300,000 after the banks had refused further credits, Mr. Gifford stated.



### OPENING FOR MOTOR TRACTORS IN FORMOSA

AGRICULTURAL motor tractors were first used on sugar plantation work in the early summer of 1919, writes H.M. Acting Consul at Tamsui, in the British Board of Trade Journal. At present there appears to be about 20 of such tractors in use in the island. All are of American manufacture and range up to 75 horse-power, so far as has been ascertained. They were imported through the medium of a British firm.

Two of the sugar companies have more tractors on order, and it is understood that a third is also about to make use of them.

Those companies which have tractors already in use seem to be well satisfied with them, and it is probable that a good number of the other companies will follow suit in the course of time.

To give some idea of the opening which may exist for the sale of agricultural tractors it may be mentioned that the area under sugar cane in Formosa is, in an average year, about 250,000 acres. There are probably over 30 companies with a capital of not less than 1,000,000 yen each, engaged in the sugar industry. The aggregate authorized capital of these companies is over 200,000,000 yen, one-half of which has been called up. One company has an authorized capital of 40,000,000 yen and three others a capital of 25,000,000 yen each. Nearly all the older established concerns have been making enormous profits during the past few years, and the present is an excellent opportunity for pushing the sale of modern appliances and machinery. Competition, however, will become increasingly difficult as time goes on.

### NEW GARAGE

THE Ross Motors Company, Limited, of Winnipeg, a recently incorporated concern, is building a new garage on Sherbrooke Street. The new building will be 120 feet deep and 100 feet wide, and will be one of the biggest all garage structures in the city. The construction is of tile, trimmed with red brick and finished with cream stucco. Two driveways will lead into the garage. The new firm will specialize in automobiles, repairs and storage.

Those financially interested in the new concern are George and Gordon Ross, Fred Sorenson and D. J. Mooney. Mr. Sorenson was with the Western Canada Motor Car Co., Ltd., as head of the mechanical department, for several years, later heading the same department of the Willys-Overland, Ltd. For the past two years he has been in the garage business at Dufferin, Man. He will have charge of mechanical work. Gordon Ross has been with the Western Canada Motor Car Co. for the past four or five years.

### FORD PROFITS 67 PER CENT.

PROFITS equivalent to 67 per cent. of the \$7,000,000 of capital stock were earned by the Ford Motor Co., of Canada, in the year ending July 31.

George M. McGregor, vice-president and general manager of the plant, reports that net profits for the year were \$4,696,243, after deduction of \$968,590 in business profits, taxes and all other expenses.

Dividends paid amounted to \$1,750,000, leaving surplus on July 31 last at \$8,216,305, as compared with \$5,270,061 at July 31, 1919.

The showing is made on a production of 55,616 cars, exclusive of tractors.

### FOUNDRIES AND FORGINGS

SHAREHOLDERS of Canada Foundries & Forgings, Ltd., approved the sale of the Delaney Iron & Forge Co., Inc., of Buffalo, at a special meeting last week. At a previous meeting of the directors a by-law authorizing the sale of the property was passed, and this was later approved by the shareholders. Provision is made that the bargain must be finally completed within the next sixty days.

### COMMERCIAL MOTOR EXHIBITION, OLYMPIA, LONDON

THE greatest progress made by industrial motors will be strikingly revealed in the forthcoming Commercial Show at Olympia, London, England, which will be held in October, from the 14th to the 23rd.

The exhibition will constitute a world's record, being the largest of its kind ever organized. Over 400 industrial motor vehicles of all types (petrol, steam and electric) will be shown. This will include not only road transport vehicles, but municipal service vehicles, such as road-sweepers, fire-engines, etc. Also road-tractors, factory trucks, etc. Government officials representing practically every country have been invited to visit the exhibition.

### J. I. CASE WORKS EXPANDS

DUE to an increase in the demand for their products the J. I. Case Plow Works Company announce a night shift will be added to their force of day workers at Racine, Wis.

This new addition of men is crowding the present factory somewhat but workmen are bringing to completion the new buildings which formed the building program this year of this company. This building program takes in six up-to-date, modern constructed buildings. Work is being rushed on these buildings as fast as possible, especially the buildings that will comprise the units of the new Wallis Tractor plant. The moving of the entire Wallis Tractor plant to its new buildings will be started immediately.

### CONCRETE MOTOR CAR

AN English concern announces that it is building a car which will retail at \$250. The new car will be constructed of a new substance which is described as a kind of concrete, which is light but strong and durable, produced from waste materials, such as slag, clinkers and sawdust, and covered with a metal solution. All parts, including wheels and chassis, will be stamped out, each complete in one piece and then fitted together.

### JOHN DEERE EXTENDING PLANT

THE John Deere Manufacturing Co., Ltd., of Welland, Ontario, are making some additions to their plant. The additions consist of a new office building, additions to the steel storage, the paint shop and the warehouse. The old office buildings will be used for manufacturing operations.

With these additions the firm hopes that the plant will be able to increase materially the output of the John Deere implements.

### AN OPEN SHOP

THE labor unions of Chicago have purchased a cemetery, where only members of the union may be buried.—News item.

All his life in a union shop  
He'd daily earned his bread:  
They buried him in a union grave  
When the union man was dead.

He had a union doctor,  
And he had a union nurse;  
He had a union coffin  
And he had a union hearse.

They put him in a union grave  
When he was good and dead;  
They put a union monument  
Just above his head.

And then he went to heaven,  
But to stay he didn't care;  
He kicked because he said that some  
Nonunion men were there.

He went down to the other place,  
And there produced his card,  
Then Satan drew an earnest face  
And studied good and hard.

And then he laughed, his hands did rub,  
Till he thought he'd never stop,  
"Lord bless my soul," said Beelzebub,  
"Why, this is an open shop."

# Aikenhead's

"The Sign of Better Service"

## Weaver Auto Hoist

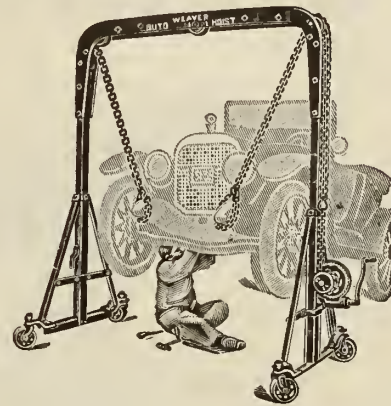

Single or Double Suspension—Safety—Worm Hoist—Ball and Roller Bearing Casters.

This is one of the most convenient and useful articles of garage equipment on the market. Note particularly the unobstructed space under the car, allowing ample room for two or more mechanics to work with absolute freedom.

The peculiar design of this Hoist permits it to be operated in very cramped quarters. It can be run into position over a car, in a crowded shop without requiring more than 12 to 14 inches space on either side of the car.

The frame of the Weaver Auto Hoist is designed so as to permit the height of the arch to be increased approximately 12 inches, allowing the uprights to be raised to the desired height in the braces on either side, by means of the chain hoist. This increased height enables the Hoist to raise the rear end of a limousine or a touring car with the top up, for removing the rear system.

Price, \$183.00

AIKENHEAD HARDWARE LIMITED  
TORONTO, CANADA

## BIRDSELL CLOVER HULLERS

Best for Threshing,  
Hulling and  
Cleaning

Little Red or Common Clover Seed  
Big English or Mammoth Clover Seed  
Alsike Clover Seed  
Sweet Clover Seed



### THREE SIZES FOR CANADA

No.	Cylinders	Capacity	Power Required
No. 2	27" x 32"	3 to 5 bushels per hour	6 to 8 H. P.
No. 1	30" x 36"	5 to 7 bushels per hour	8 to 10 H. P.
No. 8	40" x 52"	7 to 10 bushels per hour	10 to 12 H. P.

WE HAVE A SIZE TO SUIT EVERY NEED

## ANN ARBOR HAY PRESSES

If in the market for a Hay Baler we can furnish in any size to meet your requirements. Write us or call and see us while in the city.

**Birdsell Manufacturing Co.**

Foot of George Street  
Toronto, Canada



# MALLEABLE CASTINGS for TRACTORS

The Pratt & Letchworth  
Co., Limited

General Sales Office:  
Transportation Building  
Montreal

## Cylinders Reground

Our plant is specially equipped for this work and our mechanics are experts, many of them with automobile factory experience.

PISTONS, RINGS AND PINS  
made on short notice.

OXY-ACETYLENE WELDING  
Special discount to trade.

Advance Machine & Welding Company  
177F Canning St., MONTREAL

WE GIVE

## "Quality and Service"

IN

## TRACTOR and TRUCK STEEL CASTINGS

Joliette Castings & Forgings Limited

Head Office:  
Transportation Bldg., Montreal

Works:  
Joliette, Que.

# WESTERN NOTES



## MANITOBA

WINNIPEG. — The Auto Painting Co. has removed from 603 Wall Street to 424 Graham Avenue.

BINSCARTH. — Pizze Bros. have sold their implement and automobile business to J. K. Hay.

BRANDON. — Authority to increase their capital stock has been received by the Townsley Manufacturing Company.

## ALBERTA

MAGRATH. — N. F. Kent, an implement dealer here, died recently.

EDMONTON. — A new auto accessories and specialties business has been opened here by Messrs. Moyan and Kitchen.

MANTON. — Rhodes Bros. have bought the Nanton Garage and machine shop formerly conducted by C. M. Walsworth.

CAMROSE. — Mr. Smith, of the implement business of Peters and Smith, has severed his connection with that concern.

HANNA. — T. H. Williams has purchased the tire hospital formerly conducted by Strathern and Marshall. He will handle all kinds of repairs, including retreading.

WETASKIWIN. — Fire recently destroyed an automobile and private garage owned by Mr. Baldry, Thuisis Street. The damage is estimated at about \$700.

EDMONTON. — The Empire Garage on 102nd Street, is a new addition to the city's automobile industry. It is a fire-proof building and has all modern equipment. There is renting space for 150 cars.

CALGARY. — The new Motor Truck License has boosted the monthly returns of the city license office. Four hundred and eight licenses were issued, and \$1,856.53 collected during the month of August against the \$996.28 collected during the same month last year. One hundred and twelve motor trucks provided \$570 of this money.

## SASKATCHEWAN

REGINA. — Incorporation is announced of the City Vulcanizing Company.

MILESTONE. — S. Krovoski has purchased the implement business formerly conducted by J. E. Johnstone.

NOKOMIS. — The implement business of Jamieson and McKirdy has been purchased by G. C. Felske.

REGINA. — The Cleveland Tractor Co. is considering erecting a warehouse on Ottawa Street.

MOOSE JAW. — The Moose Jaw Auto Supply Company was incorporated recently.

MONTMARTRE. — G. W. Brown has sold his implement business to the Legal Trading Company.

LUMSDEN. — G. S. Felsk has purchased the implement business of McLaren and Brown.

YORKTON. — The Auto Supply Co. has purchased the property on which their garage is located. It is 50 x 120 feet.

DRUID. — The Druid Automobile Club has erected sign posts east and west of the town for the guidance of motorists travelling through this district.

EASTEND. — C. Davis has purchased a half interest in the garage business of W. Wilton. The business will henceforth be conducted under the name of Wilton and Davis. They have the Chevrolet agency.

ELBOW. — J. Todd is erecting a new garage on Main Street. It will be of concrete, 40 x 80 feet, and will be up-to-date in every respect.

STAR CITY. — F. B. McIntyre has taken a partner into his implement business. The firm's name is now McIntyre and Dorwood.

REGINA. — The Moynan Motor Company, Ltd., has been organized with a capital of \$100,000. The company will handle the Studebaker and Nash cars.

SASKATOON. — The Samson Tractor Company of Canada, whose headquarters are at Oshawa, has been registered to do business in Saskatchewan, Alberta and Manitoba.

WEYBURN. — Messrs. Clark Bros. and Bell have erected a new garage in which they have now taken up their headquarters. The garage is 50 x 100 feet, built of brick and tile, and is equipped with modern machinery.

KERROBERT. — J. M. Kosid has decided to erect a new garage to replace the one destroyed by fire recently. It will be 50 x 33, one storey high, and built of brick. The building will be steam heated throughout.

## BRITISH COLUMBIA

VANCOUVER. — The Giant Motor Truck Company, Limited, has been incorporated with authorized capital of \$100,000.

VICTORIA. — The Island Vulcanizing and Accessory Works has gone out of business.

KEREMEOS. — J. F. Madore, proprietor of the Keremeos Garage, has enlarged his premises. He has the Chevrolet and Ford agencies.

VERNON. — Crydeman and Kennedy, Ltd., is the new name of the implement concern formerly conducted under the name of Neil and Crydeman.

VANCOUVER. — The auto supply and repair men of British Columbia, who decided in March to throw in their lot with the Retail Merchants' Association, are now enjoying the full benefits of the association, as their trade section is now a materialized fact.

## BECOMES MINISTER OF AGRICULTURE

G. J. H. MALCOLM, a member of the Manitoba Legislature for eleven years and a prominent grain grower, was formally sworn in as Minister of Agriculture for Manitoba today. Mr. Malcolm is the member for Birtle, and succeeds the late Hon. Valentine Winkler, deceased.

## THESE MEN ARE ALIVE

THE following implement and auto dealers were present at the annual convention held in Moose Jaw on June 8th, 9th and 10th, 1920:—

W. W. Gardiner, Aneroid; G. W. Matheson, Craik; John Hewitson, Craik; C. W. Wilson, Central Butte; T. T. Turner, Eyebrow; J. A. Forcier, Gravelbourg; F. Martz, Holdfast; W. H. Jays, Hawarden; J. F. Funk, Herbert; S. Krescy, Kipling; J. H. Williams, Kincaid; E. R. Caldwell, Lawson; J. M. Walkup, Limerick; Clem. Alexander, Hugh Rorison, F. Nason and J. M. Murdock, Moose Jaw; J. Hodges, Mortlach; J. S. Darg, Meota; W. A. Harvey, Macoun; John Doan and H. A. Davidson, Pense; C. E. Conlin, Rosetown; W. J. Keller, Shaunavon; A. B. Foote, Success; J. H. Hannah, Trux; G. A. Turner, Tugaske; H. E. Hamilton, Unity; J. LeBoldus, Vibank; H. C. Nickel, Wymark; J. J. Polson, Regina; A. A. Thomson, Winnipeg.



**MAYBE ADAM  
LAUGHED  
AT THESE**

An old Scotch woman, very fond of gossip and a dram, was induced to begin the New Year by signing the temperance pledge. Calling upon a friend one day, the bottle was produced, and a glass handed to her, "Na, na, Mrs. Mitchell," said the gossip. "I have signed the pledge ne'er to touch nor handle a glass again; but if ye'll put a wee drap in a cup I'll tak' it."

Case Eagle.

\* \* \*

A colored Baptist was exhorting. "Now, breddern and sistern, come up to the altar and have yo' sins washed away."

All came up but one man. "Why, Brudder Jones, don't yo' want yo' sins washed away?"

"I done had my sins washed away." "Yo' has, Whar' yo' had yo' sins washed away?"

"Ober at the Methodist Church." "Ah, Brudder Jones, yo' ain't been washed; yo' jes been dry cleaned."

The Barrett Trail.

\* \* \*

Little Sarah Brown, on her way to school, fell into a pool of water, with the result that she had to turn home-wards again, all dripping wet. The next day her mother sent the following note to the teacher:

"Please excuse Sara, as she fell in the mud. By doing same you will greatly oblige."—Sharples News.

\* \* \*

A young Clevelander who is always generous with his touring car tells us that he offered to take the old colored janitor of the apartment in which he resides, downtown the other day.

"Suh," grinned the ancient functionary.

"I reckon I'll wait and go on the street cyah."

"What's the matter, uncle? Are you afraid?"

"No suh—me afraid? No suh. I got to wait."

"Uncle, have you ever been in an automobile?"

"Nevah, but once, and den I didn't let all my weight down."

Cleveland Plain Dealer.

\* \* \*

Master of the house—"Why did you tell the mistress what time I came in this morning, after I expressly paid you and told you not to?"

The cook—"Sure, sir, an Oi didn't tell her. She asked me what time you got in; Oi told her Oi was so busy getting the breakfast that Oi didn't look at the clock."—Sharples News.

\* \* \*

A preacher was describing the "bad place" to a congregation of naval cadets.

"Friends," he said, "You've seen molten iron running out of a furnace, haven't you? It comes out white hot, sizzling, and hissing. Well—"

The preacher pointed a long, lean finger at the lads.

"Well," he continued, "they use that stuff for ice cream in the place I have been speaking of."—London Tit-Bits.

\* \* \*

A teacher asked a Cleveland boy in the sixth grade to write an essay on the zones. He handed this in: "The world is divided in two zones, the male and female. The male zone is temperate, intemperate or drunk. The female frigid, torrid or horrid."—Case Eagle.

# Northern Electric

AUTOMOTIVE ~ EQUIPMENT

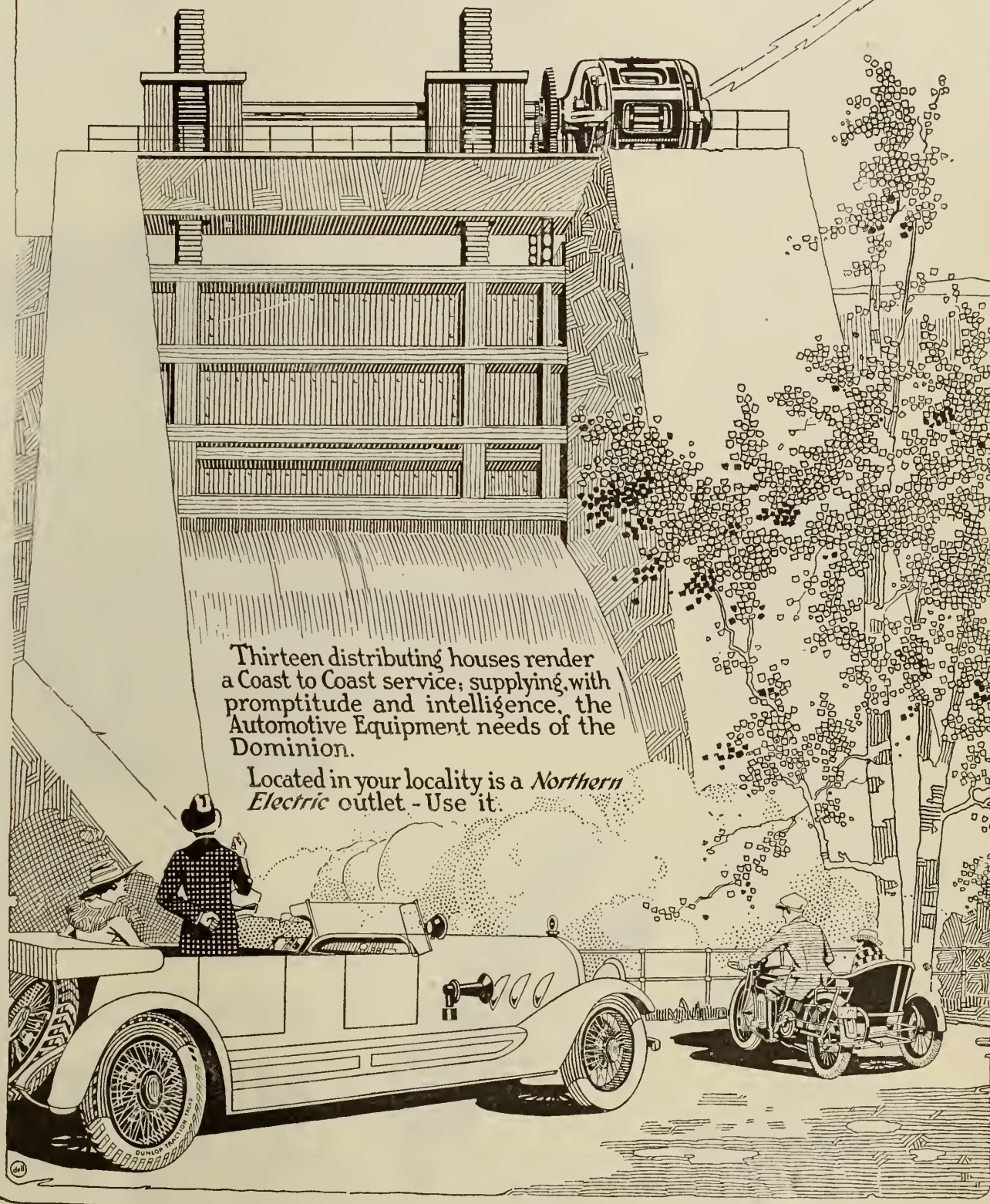

Thirteen distributing houses render a Coast to Coast service, supplying, with promptitude and intelligence, the Automotive Equipment needs of the Dominion.

Located in your locality is a *Northern Electric* outlet - Use it.

## National Advertising and Household Budgets

We are hearing a lot these days about Budgets. They affect every household in Canada. They call for intelligent and scientific distribution of expenditures. They call for the purchase of merchandise of dependable and uniform high quality at lowest possible prices.

Canadian housewives are greatly interested in Budgets—in keeping household expenses at low level—without sacrificing the quality of the food they eat, the clothes they wear, the musical instruments they use, and the household furnishings and labor-saving devices they buy.

National advertising takes the guesswork out of buying. It is the advertiser's expression of faith in his merchandise. It is a guarantee of quality. Advertising keeps the quality up. Inferior merchandise cannot masquerade in the quality clothes of advertising. National advertising increases demand and production and lowers the selling price to you.

Advertisements show you how to buy most efficiently and economically. Read the advertisements.



#### FOUR-RANGE HEADLIGHT

A NEW four-range headlight is being offered the trade by the Alvo Manufacturing Co., Ashland, Ohio. One of the most important features of the new headlight is the non-glare range which the makers claim is a distribution of light produced by shielding the lamp bulb from view so that the rays have a maximum height of 42 inches above the road and cannot throw a glare into the eyes of approaching motorists. The advantage of this non-glare range is that glare is made impossible without the sacrifice of lighting efficiency.

The four ranges of light are produced the makers say, by the use of two reflectors, one above the other. The upper reflector is 5 inches in diameter and the lower reflector (which is cut off in the centre by a horizontal shield) is 6 inches in diameter.

The upper reflector is a paraboloid, and the lower reflector half of a paraboloid. Both reflectors are scientifically accurate in design. They are made of spun brass, with a polished nickel surface covered by a highly polished silvered coating.

The second range meets the regulation against glare, the lamp bulb is hidden from view and the light so controlled by being cut off at the horizontal eliminating the possibility of glare reaching the eyes of approaching motorists.

The various ranges of light are obtained by a simple switch arrangement on the dash.

#### SWIVEL VALVE TIRE PUMP

THE E. M. Grant Mfg. Co., Ethbridge, Tenn., have placed on the Canadian market a new swivel valve tire pump. The makers state that in the construction of the pump the barrel is made of heavy 18 gauge steel tubing, and is finished in green enamel. The leather washer is oil treated and after long idleness it can be used without efficiency being impaired. The pump is made in three sizes. No. 1 has a 1 1/4 inch cylinder with a 20-inch stroke. No. 2 has a 1 1/4-inch cylinder and 24-inch stroke. No. 3 has a 1 1/2-inch cylinder with a 20-inch stroke.

#### ADJUSTABLE ACCELERATOR PEDAL

THE Williams Soft Pedal Co., of Cedar Rapids, Iowa, have put on the market a device which they claim eliminates leg strain on long drives, jerky acceleration, foot discomfort and spoiled shoes and prevents your driving foot from coming in contact with the heated accelerator.

The illustration shows how the pedal is constructed and it is adjusted for both men and women's heels. When not in use the rest folds out of the way or when it is desired to move floor boards. It fits any car and can be quickly attached.

#### CLARK HEATER

THIS is a car heater which burns the Clark carbon brick. The makers claim that it is smokeless and odorless and is quick and easy to operate. The same heater can be placed in the hood on the opposite side from the carburetor to keep the engine warm when the car is standing in the garage or on the street, thus ensuring good starting. It is manufactured by the Chicago Flexible Shaft Company, 5,600 Road Roosevelt Road, Chicago, Ill.

#### GARAGE DOOR HOLDER

THE Stanley Works, of New Britain, Conn., have brought out a new garage door holder, the purpose of which is to prevent doors slamming and doing damage to cars. The holder consists of a V shaped arm of heavy steel with springs, covered by a cylinder, which are said to act as a cushion. The holders are furnished in different finishes and are reversible and can be applied to right or left hand and square or curved top doors.

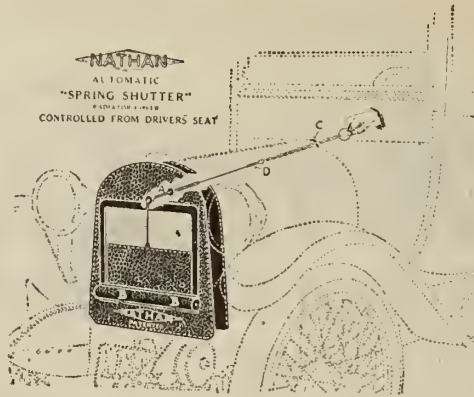

Automatic shutter radiator cover

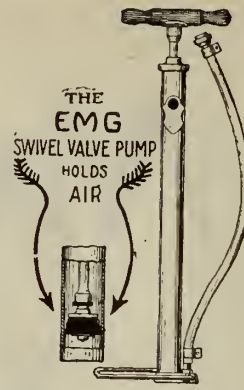

Swivel Valve Pump



Motor driven horn



Ironclad Heater



Clark Heater

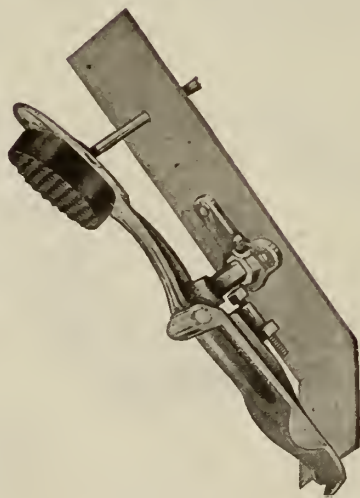

Accelerator pedal

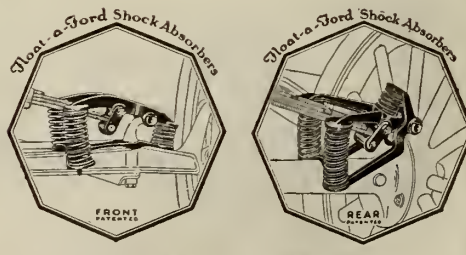

Float-a-Ford shock absorbers

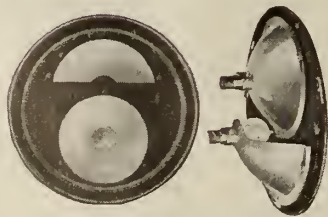

Four-range headlight



Garage door holder

#### MOTOR DRIVEN HORN

A NEW motor driven horn has been placed on the market by the Klaxon Company, of Newark, N.J., known as the Klaxon 5 Ford type. It is a motor driven safety signal especially designed for Ford cars, the makers say, and can be installed on Ford cars equipped with self-starters.

The following directions for installing are given by the makers:

Place a washer under the nut on the bolt which passes through the steering column flange; remove the centre cylinder head screw on left hand side of the engine, pass it through the large hole in the horn bracket, hold the bracket firmly against the engine, cut off brass terminal on the black horn wire and scrape off 1 1/2 inches of insulation; remove the same amount of insulation from the short piece supplied with the device, twist both securely together and tape joint. Change the black wire leading to the push button from its original position to the second terminal block on the dash and tighten the screws. A loud, clear sound should be produced.

#### MOTOR GRIP TRANSMISSION LOCK

THIS is a new lock for Ford cars operating on somewhat different principles from conventional transmission locks. It is easy to install, the makers say, only a screwdriver being required for that purpose. A small hole is bored in the floor for allowing the barrel housing of the lock to extend through the floor a short distance for inserting the key. In operation the mechanism of the lock forces a toothed cam against the fly-wheel of the engine and at such an angle that should attempt be made to turn the engine over it would result in forcing the cam even more tightly.

At the same time the cam locks the fly-wheel the housing cover is locked in place on the underside so that it is impossible to force the cover off by means of a jimmy. Thus the Motor-grip lock at one operation locks the engine, fuel feed, transmission, crankshaft and itself. It is manufactured by the Wright Accessories Corporation, Atlanta, Ga.

#### SHOCK ABSORBER

THE Float-a-Ford shock absorber manufactured by Motors Sundries, Ltd., 42 Foy Bldg., Toronto. The principle of this device is to absorb both upward and downward shocks, three springs being provided for the purpose. The makers claim that the device allows free expansion and contraction of the Ford spring and prevents side thrusts. The shock absorbers are produced in three weights—touring, coupe, sedan and commercial and roadster.

#### AUTOMATIC SHUTTER RADIATOR COVER

THE Nathan Novelty Mfg. Co., 55 Fifty Avenue, New York, have placed on the market a new radiator cover. It consists of a frame coated with rubber and rubberized to the Kersey felt lining. It is operated from the driver's seat, and the makers say unlimited adjustment can be made even when the car is in motion. The spring shutter regulates the temperature of the motor as it operates from the bottom up, and radiators freeze at the bottom first.

#### IRONCLAD MOTOR HEATER

THIS motor heater is said to be an improvement on the Mayall heater. The makers claim that less current is consumed than formerly and the element is adjustable. The device allows the motorist to take advantage of arrangements made by some municipalities for power outlet on the street to which heaters on motor cars may be attached. The heater consists of a steel housing with enlarged space for water in which is inserted the nickel attachment. It is the product of Motor Sundries Ltd., 42 Foy Building, Toronto.



**ADJUSTING THE DISK HARROW HITCH**

(Continued from page 16.)

ter. In neither case was there any weight on the harrow.

The disk blades are high-carbon steel. They are accurately made and have a sharp edge when delivered to the dealer. This sharp edge is put on the disk blades because they are supposed to cut the soil, and to do this well calls for a sharp cutting edge. In manufacture, this edge is put on the blades by rolling. The blade is set on a pin and revolved by and between the two hard rollers through which the edge passes. Pressure on these rollers draws out the edge, sharpens and at the same time tends to harden this cutting edge. The dealer should, therefore, instruct the farmer to try to keep the disk blades in this condition. It will be a big help in getting the most out of this implement with the least draft. It is a good plan to sharpen all the blades at the beginning of each season before disking is started.

There are many ways of doing this. Many blacksmiths have a disk-sharpening machine. Where they do, it is well to take the harrow there for sharpening, since this will give the best results. If it is to be done at home, one good plan is to do it with a hammer or an anvil. The disks should all be removed from the gang bolt and very carefully pounded to remove all nicks on cutting edges. While the sharpening should always be done from the convex side, the hammering should be done from the inside, or concave side. After the hammering has been carefully done the disks may be ground on a grindstone or emery wheel. It is important to see that the blade is continually revolved so that it may be ground perfectly round. Care, too, should be exercised not to burn the edge by getting it red hot. This draws the temper and causes soft spots.

**T**HERE is another method which calls for setting the entire gang in a frame without removing each disk blade. In this case the hammering is done with a small hammer against the face of a sledge held against the edge.

It should be noted that when an edge is to be put on a disk blade by hammering or rolling it should be done by working against the inside, or concave side. On the other hand, if the edge is put on by grinding or cutting it is done from the outside, or convex side. This is an important point to remember.

It hardly seems as though such a thing as care was ever given a disk harrow. We see them out-doors at all seasons of the year. We see them in the fence corners and under trees on thousands of farms. They were left there simply because it was easier to do that than draw them back to the barn and put them in a shed for winter storage. One of the first things to have in connection with a disk harrow is a set of transport trucks or wheels. These should be used when moving the harrow on a hard road to prevent any injury to the blades.

The bearings, too, need much care. They should be gone over very thoroughly at the end or at the beginning of the season. Worn wood bushings should be replaced every season. If two wood bushings are used both should always be renewed before operations begin.

The spool bearings should be thoroughly cleaned with kerosene and the entire box packed with cup grease when assembling. The grease cup and the pipe leading to the bearings should be filled with this same cup grease.

Each disk blade should be well smeared with cup grease right after leaving the field, when yet polished—before it rusts. A cloth soaked in engine oil is a good medium with which to oil the blades. The machine should be set in a shed by all means. If an implement shed is part of the building equipment the disk harrow, like all other implements, should be set on

boards and not on the ground, which is damp and will rust any metal standing on it for any length of time.

The value that a disk harrow, or any other implement, gives the farmer is in proportion to the care given the particular machine. Good implements deserve good care. To get the maximum return for every dollar invested there must be a thorough understanding of their field operation, coupled with good care.

**BEATTY BROS. BRANCH MANAGERS MEET**

**D**URING the first part of August all branch managers met together at the head office in Fergus, Ont., to discuss plans and set quotas for the new business year, commencing September 1st. The photograph shows all branch managers and some of the head office staff. In addition to the Canadian managers, R. B. Stewart, manager at



Beatty Bros. Branch Managers Meet

London, England, came home to attend this convention. This is the first visit he has paid to Canada since the founding of the English branch.

Back Row:—M. J. Beatty, General Sales Manager; R. B. Stewart, Manager, London, Eng.; N. J. Cabeldu, Manager, St. John, N.B.; J. J. Rutherford, Sales Manager, Western Ontario; T. A. Farnell, Sales Manager, Eastern Ontario; D. R. Potter, Advertising Manager.

Front Row:—A. S. Walbridge, Manager, Montreal; W. H. Sterne, Manager, Edmonton; G. A. Reynolds, Branch

**NEW MOTOR LUBRICANT**

**C**ASTOLENE OIL, a combination of vegetable and mineral oils for motor lubrication, has just been placed on the market in Vancouver and is now to be had at practically all of the garages and oil stations in the city. Castolene oil is mixed with the gasoline, and its distributors claim that it will vaporize the fuel and thereby reach and lubricate all the upper parts of the motor and at the same time destroy all carbon that it comes in contact with. It is guaranteed to prolong the life of the motor, increase mileage and power, insure perfect ignition and make starting easier in cold weather.

**VETERAN PLOW MAKER**

**J**OHAN GULBRONSON, a plow maker at the J. I. Case Plow Works, Racine, Wis., is one of the oldest plow makers in America. He has stood by his forge and drop hammer for more than forty years and is still going strong.

**A TIRE HOSPITAL AND A REAL TIRE DOCTOR**

(Continued from page 7.)

so many tires to repair, as most of the cars are stored, we repair the soles of rubber boots. A large number of fishermen and farmers in this district use rubber top boots in the winter time. Repairing these boots and the work we get through the auto livery men who run their cars all winter we are kept busy until the season opens again.

"We buy everything for cash and conduct our business strictly on a cash basis.

"We strongly deprecate the practice of drug stores and such places selling tires because they are not in a position to give service. However I am glad to say there are practically no tires sold in our district outside of the legitimate trade. We permit no price cutting and strongly condemn it.

"If real tire men give the right service hoodoo tire sellers and price cutters will soon disappear."

site in Fort Rouge, on Academy Road where they will build a plant. The factory will be constructed throughout of reinforced concrete and will cost between \$70,000 and \$80,000. Work is expected to be started on the first unit in a short time.

**AN ENGLISH CO.'S SERVICE SCHEME**

**O**NE of the largest automobile manufacturers in Britain, the Napier Automobile Company, has inaugurated a unique service system which comes automatically into effect with every car delivered to the owners.

When a car is handed over, the owner is advised of the "Service" arrangement, and the suggestion made that one of the company's inspectors should pay a visit as soon as possible after the car had been put in commission, in order that he may be of assistance to the owner or his driver as the case may be, by giving the benefit of his experience in regard to the most satisfactory operation of the chassis in question.

After the first visit, the car is inspected periodically during the year. A few of the points dealt with are:—

(1) The correct method of starting up the engine, and advice as to the care of any electrical equipment and body work.

(2) Drawing attention to any item in the chassis which requires special attention, and the best method of making adjustments when same become necessary—to the brakes, clutch, steering, etc.

(3) Demonstrations of the best method of changing gear, either up or down, so as not to cause excessive wear or damage to the gear-box.

(4) Full instructions regarding lubrication of the chassis generally.

At every inspection, the company's expert who thoroughly tests the car on the road, and any "tuning up" and minor adjustment found necessary in carried out by him.

A complementary feature of this service scheme is that Napier dealers are expected to carry a stock of Napier parts so that they may be in a position to give prompt service when called upon.

After each inspection, owners are given particulars of the report made by the visiting engineer.

Two points may be noted about this scheme. Firstly, it has justified itself, to the satisfaction alike of the makers and owners of Napier cars. Secondly, the Napier Company's agents are gainers, alike in being kept up to "the scratch" as regards their own relations with the makers and owners of these cars, and in being assured of obtaining spares at short call. It is only a matter of time when this sort of motor service will be as universal as motor vehicles, and every garage will have to be justified as much by its capacity to maintain vehicles sold from it, as to increase the output of new ones.

**AUTOMOBILES IN CANADA**

**A**UTOMOBILE registrations in Canada in 1919 aggregated 341,396. The returns by Provinces are:

Prince Edward Island	967
Nova Scotia	10,290
New Brunswick	8,306
Quebec	33,547
Ontario	144,804
Manitoba	30,118
Saskatchewan	56,855
Alberta	34,000
British Columbia	22,420
Yukon Territory	89
<b>Total</b>	<b>341,396</b>

**BARN AND IMPLEMENTS BURNED**

**O**N October 4, fire caused by a spark from an engine while cutting corn destroyed a large barn, some implements and a portion of this season's grain on a farm owned by Philip Weber on the road between St. Jacobs and Elmira. The loss, which is partly covered by insurance will amount to about \$6,000.

**NEW "WINNIPEG" CAR**

**T**HE Winnipeg Motor Cars, Ltd., which was recently incorporated with a capital of \$1,000,000, will build a car to be known as the Winnipeg. The officials of this company are: President and manager, F. A. Ogletree; vice-president, L. Arsenault; secretary-treasurer, D. E. Ogletree; superintendent, C. L. Lan.

The company has secured a five-acre

**WILLYS-OVERLAND PRICES CUT**

**W**ILLYS - OVERLAND, LIMITED, Toronto, announce reduced prices on all their models. The reductions vary from \$100 to \$200 on Overland cars which are manufactured in Toronto and from \$115 to \$375 on Willys-Knight cars. The Overland 4 car now sells for \$1,315 F.O.B. Toronto, including both excise and sales tax.



# Simplicity

WITH the Simplicity Line on the floor, Dealers can supply the right type of engine for every power need.

Simplicity Engines are built in 1½, 3, 4½, 6, 8, 10, 12, 14 and 16 H.P. Gasoline and Kerosene — Stationary, on skids or portable.

Simple in design and construction, powerful and economical. Simplicity Engines are the profit-making line for Dealers to handle.

Write at once for Price List and Catalog.

## The Turner Manufacturing Co.

441 Lake Street, Port Washington, Wis., U.S.A.

Export Department, 44 Whitehall St., New York City

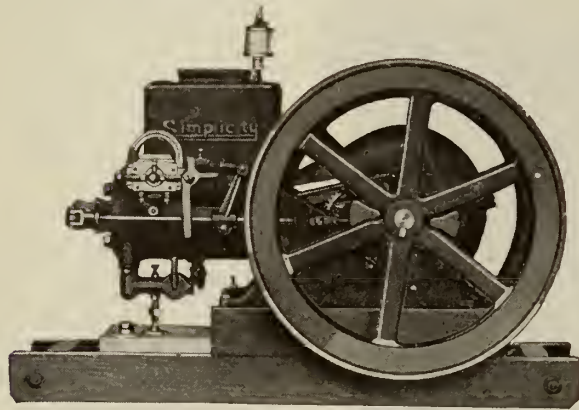

## It Docks at Your Desk

Our service brings to your desk news items collected from the newspapers relating to your line of business.

Often you plan your affairs on market conditions or new developments, but you could plan much better with all information before you from the whole of Canada.

These newspaper clippings have proved most valuable to business houses, saving time in searching files and often being turned to good account, getting contracts and orders.

We cover all parts of Canada and United States and read for all subjects discussed in the press.

Have the news packets arrive regularly at your desk with a cargo of timely news.

Canadian  
Press Clipping Service  
143-153 UNIVERSITY AVE., TORONTO

## Dairy and Household Supplies

### FARM LIGHT PLANT AT GARDEN PARTY

L. S. HANEY, an implement dealer of Fenwick, and a story of whose business appeared in a recent issue of M.T.I., is a hundred per cent. dealer. He handles farm lighting plants and is a strong believer in demonstrations. He has a demonstrating plant fitted up in his store and whenever he gets the chance of putting on a demonstration at a public function such as garden parties, etc., he is Johnny on the spot. The following incident of such a demonstration, taken from Farm Links, occurred in the latter part of July at a party near Fenwick:

The garden party at which the demonstration was given was held under the auspices of the Ladies' Aid of the Baptist Church at Marshville, on the grounds of Mr. Miner, who has purchased the plant.

The plant was centrally located on the left hand side of the entrance to the ground, so nobody could possibly miss seeing it.

The lights were strung in three circuits. One lit the platform, which was about 12 x 15 ft., having ten 20 watt lamps, with a drop cord and extension run from the socket to light the dressing room in rear of the stage. Another circuit having seven lights was run some distance in front of the stage, lighting up part of the grounds and an ice cream booth, and giving the audience plenty of light. The third circuit contained only two lights, one of which was placed at the entrance of the grounds for the convenience of the ticket sellers, and the second was placed beside the plant, providing plenty of light for interested parties to inspect the plant.

The exhaust was led into a hole in the ground and the other piping arranged almost identically with the piping on the demonstration plant in the basement.

The engine was left running during the first half of the programme and no complaints were heard at all of the noise made by the plant.

The demonstrators went to as many different parts of the audience as possible without disturbing anyone, and nowhere did they experience any difficulty in hearing the artists, from the noise from the plant.

During the early part of the evening they experienced difficulty arising from water in the gasoline. Finally, due to this cause, the engine stopped, but they kept it running by constantly filling the priming reservoir.

After the intermission the lights were run from the battery alone, and everything was most satisfactory. Everyone was loud in their praise of the lights, especially the artists, who said they had never had a better or more satisfactorily lighted platform.

On Saturday morning Mr. Haney installed the plant and wired a couple of lights temporarily for Mr. Miner, for use until the permanent wiring is installed.

Mr. Haney's demonstration was a great success, due to his untiring efforts and personal acquaintance with a great many of those who attended.

### DAIRY INDUSTRY DEVELOPING

THE Dairy Industry of Alberta is steadily developing. While in the year 1912 fifty-three creameries produced some 3,000,000 pounds of butter, in 1919 the same number of dairies turned out 10,500,000 pounds, at a value of about \$5,500,000. The total value of Alberta's dairy products during 1919 was estimated at \$31,500,000.

### OIL ENGINE DRIVEN LIGHTING PLANT

A FARM lighting plant driven by an oil engine that will operate on thin crude oil, kerosene and low grade fuel oil down to 28 degrees Baume is being put on the market by the Petroleum Engine and Mfg. Co., Chicago. It is said that one gallon of fuel oil will operate the unit for four hours under normal conditions, and one gallon of lubricating oil is sufficient for several weeks' operation.

The outfit consists of a three h.p. vertical engine, a Westinghouse electric one and one-half k.w. generator and control panel, and an ample capacity storage battery. The engine and generator, flexibly coupled together, are mounted on a rigid cast iron sub-base and the control panel is mounted upon the generator frame.

The outstanding features claimed for the engine are the extreme simplicity of construction, fuel economy and reliability. The usual electric ignition system and fuel mixing valves are eliminated as the ignition of the fuel is caused by the heat of compression. The engine operates on a four-stroke cycle.

The 2¾ gallon fuel tank is located in the base of the engine from where the fuel is pumped to a small compartment on top of the fuel ejector. A needle valve mounted within the body of the fuel ejector allows just the correct amount of fuel to pass into the fuel cup. All excess fuel flows back through an overflow pipe to the fuel tank.

The lubricating oil is contained in a basin in the engine base from which it is pumped under about 20 pounds pressure to all bearings. The oil returns to a pump through a strainer so that it may be used again. A level on top of the engine is held upright by a spring when the engine is not operating. When the level is in this position the air intake valve is open and the compression on the cylinder is relieved, thus making the engine easy to crank. Cranking may be either by hand or by the generator acting as a motor using energy from the storage batteries. To obtain a large starting torque and not draw excessive current from the battery the 40-volt 1100 r.p.m. direct current shunt generator has a special series winding which enables it to act as a compound motor.

The control panel is of slate and has mounted on it a line switch, a starting switch, a stopping switch and also a switch to disconnect the battery from the generator so that the engine may be used for mechanical power purposes independent of the electric circuit. In addition to these four switches, the panel contains an ammeter, a field rheostat, a clock control for stopping the engine when the batteries have been fully charged, and a reverse current relay to prevent the battery discharging through the generator when the generator is not operating or when the generator voltage is lower than the voltage of the battery.

### SASKATCHEWAN'S BUTTER PRODUCTION

PROVINCIAL DAIRY COMMISSIONER REED says that Saskatchewan, which produced 6,620,000 pounds of creamery butter last year, is expected to produce 7,000,000 pounds this year.

IN order to feed off two inches daily from a fourteen foot silo it will take from 30 to 35 cows fed at the rate of 30 pounds each per day.



# The Name "De Laval" on a cream separator makes it easier to sell



Because the name "De Laval" stands for honest value and real service wherever cows are milked ;

Continuous and liberal advertising has made the name "De Laval" a household word in farm homes the world over ;

Fifty thousand of the best and most representative dealers, having their customers' best interests at heart, are distributors of De Laval Separators ;

The name "De Laval" has always meant a fair and square deal, both for the dealer who sold the machine and for the farmer who bought it.

The name "De Laval" is worth real money to the dealer who has the De Laval selling agency.



*There is no better time than right now to send in an application for a De Laval contract*

**THE DE LAVAL COMPANY, Ltd.**

MONTREAL PETERBORO WINNIPEG EDMONTON VANCOUVER

*50,000 Branches and Local Agencies the World Over*



CANADIAN  
**Motor Tractor and Implement Trade Journal**  
**BUYERS DIRECTORY**

This directory will help you with your buying and your planning. The advertisers listed here are thoroughly reliable and leaders in their respective fields. They are looking for live, wide-awake representatives. Study their advertisements carefully because they contain valuable information which will dovetail with your plans. We are glad to go to the trouble of arranging this list—to make it easy for you to select new lines. If it so happens that what you want is not here, write us, and we will tell you where to get it.

**ACCESSORIES**

Advance Machine & Welding Co., Montreal.  
Burlington Products, Ltd., Hamilton, Ont.  
Canadian General Electric Co., Toronto.  
Canadian Car & Foundry Co., Montreal, Que.  
Canadian Raybestos Co., Peterborough, Ont.  
Champion Spark Plug Co., Windsor, Ont.  
Guelph Spring & Axle Co., Guelph.  
Northern Electric Co., Ltd., Montreal.  
Apollo Plug Mfg. Co., Birmingham, Eng.  
R. F. Sedgley, Inc., Philadelphia, Pa.  
McCord Mfg. Co., Walkerville, Ont.  
Kinzinger Bruce Co., Niagara Falls, O.  
Aikenhead Hardware Co., Toronto.  
Hyslop Bros., Toronto.  
Kale Stamping Co., Walkerville, Ont.  
K. P. Products Co., 250 West 54th St., New York City.  
Lamontagne, Ltd., Montreal.  
Perfex Radiator Co., Racine, Wis.

**AUTOMOBILE BUMPERS**

Kinzinger, Bruce & Co., Ltd., Niagara Falls, Ont.

**AUTOMOBILE CHAINS**

**AUTOMOBILE JACKS**

Kinzinger, Bruce & Co., Ltd., Niagara Falls, Ont.

**AUTOMOBILE MIRRORS**

Kale Stamping Co., Walkerville, Ont.

**BARN EQUIPMENT**

**BEAN MACHINERY**

John Deere Mfg. Co., Welland, Ont

**BEEF MACHINERY**

International Harvester Co., of Can., Ltd., Hamilton, Ont.  
John Deere Mfg. Co., Welland, Ont.

**BEARINGS**

Hyatt Roller Bearing Co., Chicago, Ill.

**BINDERS**

The Frost & Wood Co., Ltd., Smiths Falls, Ont.  
International Harvester Co., of Can., Ltd., Hamilton, Ont.

**BELTING**

**BREAK LINING**

Canadian Raybestos Co., Peterborough, Ont.

**BATTERIES**

**CARRIAGES**

Cockshutt Plow Co., Brantford, Ont.

**CREAM SEPARATORS**

De Laval Co., Ltd., Peterboro, Ont.  
International Harvester Co., of Can., Ltd., Hamilton, Ont.  
R. A. Lister Co. (Canada), Ltd., Toronto

**CEMENT MIXERS**

**CASTINGS**

Joliette Castings & Forgings Ltd., Montreal and Joliette, Que.

**CORN HARVESTERS**

Cockshutt Plow Co., Brantford, Ont.  
International Harvester Co., of Can., Ltd., Hamilton, Ont.

**CORN MACHINERY**

International Harvester Co., of Can., Ltd., Hamilton, Ont.  
John Deere Mfg. Co., Welland, Ont.

**CULTIVATORS**

Cockshutt Plow Co., Brantford, Ont.  
John Deere Mfg. Co., Welland, Ont.  
Massey-Harris Co., Toronto.  
The Frost & Wood Co., Ltd., Smiths Falls, Ont.  
International Harvester Co., of Can., Ltd., Hamilton, Ont.

**CUTTERS**

Butterfield & Co., Inc., Rock Island, Q.

**DAIRY SUPPLIES**

International Harvester Co., of Can., Ltd., Hamilton, Ont.  
R. A. Lister Co. (Canada), Ltd., Toronto  
DeLaval Dairy Supply Co., Peterboro.

**DIES**

Butterfield & Co., Inc., Rock Island, Q.

**DISCS**

**DITCHING MACHINES**

**DRILLS**

**DRILLS, TWIST**

Butterfield & Co., Inc., Rock Island, Q.

**DRILLS, GRAIN**

Cockshutt Plow Co., Brantford, Ont.  
International Harvester Co., of Can., Ltd., Hamilton, Ont.  
John Deere Mfg. Co., Welland, Ont.  
The Frost & Wood Co., Ltd., Smiths Falls, Ont.

**ELECTRICAL EQUIPMENT**

Can. General Electric Co., Ltd., Toronto.  
Northern Electric Co., Ltd., Montreal.

**ENGINES**

Gilson Mfg. Co., Ltd., Guelph, Ont.  
International Harvester Co., of Can., Ltd., Hamilton, Ont.  
John Deere Mfg. Co., Welland, Ont.  
The Frost & Wood Co., Ltd., Smiths Falls, Ont.  
R. A. Lister Co. (Canada), Ltd., Toronto  
The Turner Mfg. Co., Port Washington, Wis.

**ENSILAGE CUTTERS**

Gilson Mfg. Co., Guelph, Ont.  
International Harvester Co., of Can., Ltd., Hamilton, Ont.

**FEEDERS**

John Deere Mfg. Co., Welland, Ont.

**FARM MACHINERY**

Cockshutt Plow Co., Brantford, Ont.  
John Deere Mfg. Co., Welland, Ont.  
International Harvester Co., of Can., Ltd., Hamilton, Ont.  
The Frost & Wood Co., Ltd., Smiths Falls, Ont.  
R. A. Lister Co. (Canada), Ltd., Toronto  
Gilson Engine Co., Guelph, Ont.

**FEED CUTTERS**

Gilson Engine Co., Guelph, Ont.

**GREASE CUPS**

**GRINDSTONES**

S. Vessot & Co., Joliette, P.Q.

**GRINDERS**

International Harvester Co., of Can., Ltd., Hamilton, Ont.  
R. A. Lister Co. (Canada), Ltd., Toronto  
S. Vessot & Co., Joliette, P.Q.  
Gilson Engine Co., Guelph, Ont.

**HARROWS**

Cockshutt Plow Co., Brantford, Ont.  
International Harvester Co., of Can., Ltd., Hamilton, Ont.  
John Deere Mfg. Co., Welland, Ont.  
The Frost & Wood Co., Ltd., Smiths Falls, Ont.

**HAY LOADERS**

International Harvester Co., of Can., Ltd., Hamilton, Ont.  
John Deere Mfg. Co., Welland, Ont.  
The Frost & Wood Co., Ltd., Smiths Falls, Ont.

**HARDWARE**

Aikenhead Hardware Co., Toronto.

**HAY RAKES**

John Deere Mfg. Co., Welland, Ont.  
The Frost & Wood Co., Ltd., Smiths Falls, Ont.

**HAY CARRIERS**

**HAY PRESSES**

Birdsell Mfg. Co., Toronto.  
International Harvester Co., of Can., Ltd., Hamilton, Ont.

**HULLERS (Clover)**

Birdsell Mfg. Co., Toronto.

**LIGHTNING SYSTEMS**

R. A. Lister Co. (Canada), Ltd., Toronto  
Northern Electric Co., Ltd., Montreal.  
Gilson Engine Co., Guelph, Ont.

**LIME AND FERTILIZER SOWERS**

John Deere Mfg. Co., Welland, Ont.

**LUBRICANTS**

**MACHINE TOOLS**

Windsor Machine and Tool Works,  
Windsor, Ont.

**MANURE CARRIERS**

**MANURE SPREADERS**

Cockshutt Plow Co., Brantford, Ont.  
International Harvester Co., of Can., Ltd., Hamilton, Ont.  
John Deere Mfg. Co., Welland, Ont.  
The Frost & Wood Co., Ltd., Smiths Falls, Ont.  
Gilson Engine Co., Guelph, Ont.

**MARINE FITTINGS**

Northern Electric Co., Ltd., Montreal.

**MOWERS**

Cockshutt Plow Co., Brantford, Ont.  
International Harvester Co., of Can., Ltd., Hamilton, Ont.  
The Frost & Wood Co., Ltd., Smiths Falls, Ont.

**MOTOR HORNS (Electric)**

Apollo Mfg. Co., Birmingham, Eng.

**MILKING MACHINES**

R. A. Lister Co. (Canada), Ltd., Toronto

**MILLING CUTTERS**

Butterfield & Co., Inc., Rock Island, Q.

**OILS**

**PISTON RINGS**

Lamontagne Ltd., Montreal, Que.

**PLOWS**

Cockshutt Plow Co., Brantford, Ont.  
John Deere Mfg. Co., Welland, Ont.  
The Frost & Wood Co., Ltd., Smiths Falls, Ont.  
International Harvester Co., of Can., Ltd., Hamilton, Ont.

**POLICE AND FIRE ALARM EQUIPMENT**

Northern Electric Co., Ltd., Montreal.

**POWER AND LIGHT EQUIPMENT**

Northern Electric Co., Ltd., Montreal.  
R. A. Lister Co. of Canada, Ltd., Toronto.

**POWER MACHINERY**

John Deere Mfg. Co., Welland, Ont.  
International Harvester Co., of Can., Ltd., Hamilton, Ont.  
Gilson Engine Co., Guelph, Ont.

**POWER SWITCHBOARDS**

Northern Electric Co., Ltd., Montreal.

**POTATO MACHINERY**

John Deere Mfg. Co., Welland, Ont.  
Cockshutt Plow Co., Brantford, Ont.

**PULVERIZERS**

Cockshutt Plow Co., Brantford, Ont.  
International Harvester Co., of Can., Ltd., Hamilton, Ont.

**PULPERS**

Cockshutt Plow Co., Brantford, Ont.

**RAKES**

International Harvester Co., of Can., Ltd., Hamilton, Ont.  
The Frost & Wood Co., Ltd., Smiths Falls, Ont.

**REAPERS**

International Harvester Co., of Can., Ltd., Hamilton, Ont.  
The Frost & Wood Co., Ltd., Smiths Falls, Ont.

**REAMERS**

Butterfield & Co., Inc., Rock Island, Q.

**ROLLERS**

Cockshutt Plow Co., Brantford, Ont.  
Hyatt Roller Bearing Co., Chicago, Ill.

**ROLLER BEARINGS**

Hyatt Roller Bearing Co., Chicago, Ill.

**SAW MILL OUTFITS**

**SCUFFLERS**

Cockshutt Plow Co., Brantford, Ont.  
International Harvester Co., of Can., Ltd., Hamilton, Ont.  
John Deere Mfg. Co., Welland, Ont.

**SEEDERS**

Massey-Harris Co., Toronto.

**SCALES**

**SCREW PLATES**

Butterfield & Co., Inc., Rock Island, Q.

**STABLE EQUIPMENT**

**SILOS**

Gilson Mfg. Co., Guelph, Ont.

**SLEIGHS**

Cockshutt Plow Co., Brantford, Ont.  
International Harvester Co., of Can., Ltd., Hamilton, Ont.

**SILO FILLERS**

Gilson Mfg. Co., Guelph, Ont.  
International Harvester Co., of Can., Ltd., Hamilton, Ont.

**SOCKET WRENCHES**

R. F. Sedgley, Inc., Philadelphia, Pa.

**SEPARATORS (CREAM)**

R. A. Lister Co., Toronto.

**SPREADERS, MANURE**

Cockshutt Plow Co., Brantford, Ont.  
John Deere Mfg. Co., Welland, Ont.  
International Harvester Co., of Can., Ltd., Hamilton, Ont.  
Massey-Harris Co., Toronto.  
Gilson Mfg. Co., Guelph, Ont.

**SPARK PLUGS**

Machine & Stamping Co., Toronto.  
Champion Spark Plug Co., Windsor, O.  
Apollo Plug Mfg. Co., Birmingham, Eng.  
Can. General Electric Co., Ltd., Toronto.

**SPARK PLUG CLEANERS**

Champion Spark Plug Co., Windsor, O.

**STAMPINGS**

Kale Stamping Co., Walkerville, Ont.

**TELEPHONE APPARATUS**

Northern Electric Co., Ltd., Montreal.

**TRACTORS**

R. A. Lister Co. (Canada), Ltd., Toronto  
Gilson Mfg. Co., Guelph, Ont.  
International Harvester Co., of Can., Ltd., Hamilton, Ont.  
J. I. Case Threshing Machine Co., Inc., Racine, Wis.  
Massey-Harris Co., Toronto.  
The Turner Mfg. Co., Port Washington, Wis.

**TRACTOR PLOWS**

Cockshutt Plow Co., Brantford, Ont.  
International Harvester Co., of Can., Ltd., Hamilton, Ont.  
John Deere Mfg. Co., Welland, Ont.  
Massey-Harris Co., Toronto.

**TIRES**

**THRESHERS**

Can. Fairbanks-Morse Co., Ltd., Montreal.  
International Harvester Co., of Can., Ltd., Hamilton, Ont.  
J. I. Case Threshing Machine Co., Inc., Racine, Wis.  
R. A. Lister Co. (Canada), Ltd., Toronto  
Gilson Mfg. Co., Guelph, Ont.

**THREAD CUTTING TAPS**

Butterfield & Co., Inc., Rock Island, Q.

**TWIST DRILLS**

Butterfield & Co., Inc., Rock Island, Q.

**TRUCKS**

Motor Car Distributors Ltd., Montreal.  
Eastern Canada Motor Truck Co., Ltd., Hull, P.Q.  
International Harvester Co., of Can., Ltd., Hamilton, Ont.

**WHEELBARROWS**

Cockshutt Plow Co., Brantford, Ont.  
Massey-Harris Co., Toronto.

**WAGONS**

Cockshutt Plow Co., Brantford, Ont.  
International Harvester Co., of Can., Ltd., Hamilton, Ont.  
Massey-Harris Co., Toronto.

**WATER BOWLS**

**WEEDERS**

Cockshutt Plow Co., Brantford, Ont.

**WIRES AND CABLES**

Northern Electric Co., Ltd., Montreal.



# BUTTERFIELD

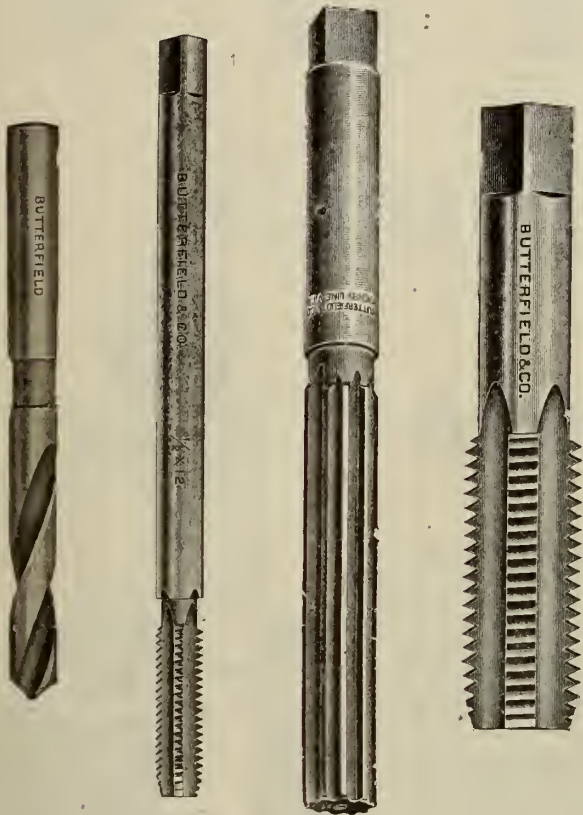

*"The tools you buy again"*

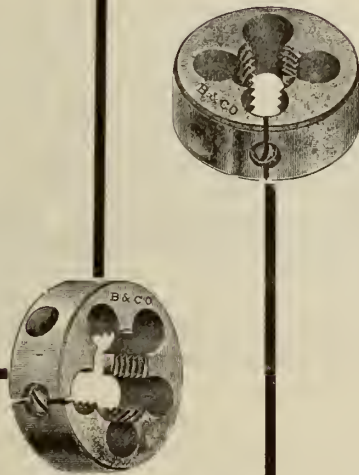

**I**F you are anxious to gain the reputation of doing the best work in your town you will use Butterfield Tools.

Butterfield taps, dies, reamers and milling cutters have a reputation for "best quality" because Butterfield tool-makers long since set out to earn for them this reputation.

And because they have earned this reputation Butterfield Tools are best fitted to help you earn the reputation to which you aspire.

**BUTTERFIELD & COMPANY** DIVISION

UNION TWIST DRILL CO.  
ROCK ISLAND - QUE., CANADA

*Toronto Office: 220 King St. West*



# Why are all Fords Equipped with

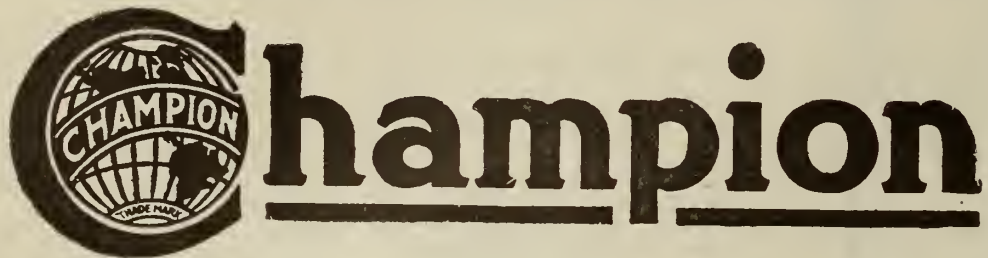

## Dependable Spark Plugs

The answer is found in the Ford instruction book which says:—

“The make of plugs with which Ford engines are equipped when they leave the factory, is best adapted to the requirements of our motor.”

Since 1911 Fords have been, and are now, Champion equipped.

For motor owners who have other makes of cars we have developed a type of spark plug to give that same unfailing dependability for which Ford motors are known. Absolute confidence can be placed in Champion Spark Plugs to carry through any emergency that an engine will stand up under.

The right plug has “Champion” on the insulator as well as on the box.

Display the Champion dealer helps and get your share of the business that our advertising has created.

Order from your jobber to-day.

**Champion Spark Plug Co. of Canada, Limited**  
**Windsor, Ontario**

*Largest factory in Canada making Spark Plugs exclusively  
and the only factory making “Champions”*



**Champion “X”**

A 15— $\frac{1}{2}$  inch  
Price 90c

Adopted by the Ford Motor Co. as standard equipment on Ford cars since 1911.



# VETERAN

## Canada's Best Truck

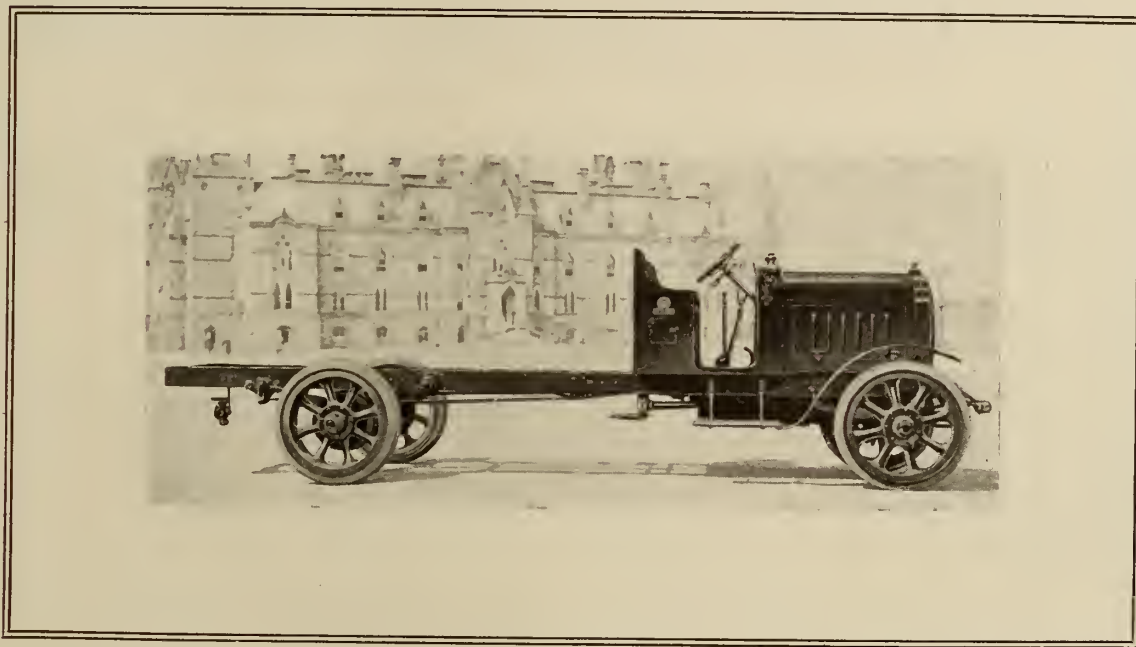

In the truck field, as in every other, there can be only one greatest value—The entire attention and resources of this organization are dedicated to the production of the one greatest motor truck value in Canada.

### EASTERN CANADA MOTOR TRUCK CO.

Limited

HULL,

QUE.

**Commercial Cars Limited, Toronto**

Distributors for Western Ontario, Manitoba, Saskatchewan, and British Columbia





## This Jumbo Truck Has Run Over 14,000 Miles Without Repairs

WOLVERINE BRAND MAPLE FLOORING  
 BLISS & VAN AUKEN LUMBER COMPANY  
 MANUFACTURERS OF  
 HARDWOOD - HEMLOCK LUMBER  
 MAPLE FLOORING  
 AND BALT  
 SAW AND PLANING MILLS - 100 & NIAGARA STREET  
 SAGINAW, MICHIGAN  
 August 14, 1920

Nelson Motor Truck Co.,  
 Saginaw, Michigan.

Gentlemen;

We have operated a two ton Jumbo truck since June 1919. It works every day except Sunday and although we have driven it between 14 and 15 thousand miles, we have not had any expense whatever to date. Our average load is about two tons and we average about 50 miles a day, which has cut our cost of delivery considerably.

We think that for everyday use, good roads and bad ones, this Jumbo truck fills the bill better than any truck we have ever owned. We are very well satisfied with it.

Very truly yours,  
 BLISS & VAN AUKEN LUMBER COMPANY  
 Per *J. Mitchell*

JWH

*Proof*

Quality of design, materials and workmanship can safely be taken for granted when such records as this one are common. Many Jumbo owners with records of 20,000 to 30,000 miles have not replaced a single part in more than 3 years hard service. The replacement cost for all Jumbo Trucks averages less than \$10 per year per truck.

Such performance means good reputation—a powerful factor in the success of Jumbo dealers.

There is a Jumbo Truck for every need—ten models with 6 capacities ranging from 3,000 to 8,000 pounds. Jumbo dealers are therefore enabled to meet the requirements of any haulage problem, all from the Jumbo line.

Write today for open territories, and full details of sales plans

Sole Distributors in Canada

**MOTOR CAR DISTRIBUTORS LIMITED**

27 McGill College Ave. Montreal, Que.

MANUFACTURED BY  
 NELSON MOTOR TRUCK COMPANY  
 SAGINAW, MICHIGAN, U. S. A.

*The COMPLETE Truck*





# CANADIAN MOTOR, TRACTOR AND IMPLEMENT TRADE JOURNAL

Published Monthly by THE MACLEAN PUBLISHING COMPANY, LIMITED, TORONTO

MONTREAL, Southam Bldg.

WINNIPEG, 1103 Union Trust Bldg.  
NEW YORK, 1133 Broadway.

VANCOUVER, 314 Carter-Cotton Bldg., 198 Hastings St. W.  
BOSTON, 734 Old South Bldg.

CHICAGO, 405-6 Transportation Bldg.

LONDON, ENG., 88 Fleet St., E.C. 4

VOL. II, No. 11

TORONTO, NOVEMBER, 1920

Subscription Price  
\$2.00 Per Year

## Apollo

### BRASS SPARK PLUGS

—are sure and satisfactory sellers!

You're on a good thing when you handle APOLLO PLUGS—they represent the highest standard of British plug manufacture, are fully tested to ensure maximum efficiency and are guaranteed to give complete satisfaction.

With the APOLLO range of plugs you can promptly meet every plug request—there are models for every type of Car, Motor Truck and Tractor engine—and every plug carries a GOOD PROFIT for YOU.

Super Mica Plug is specially designed for high-speed, high-compression engines. It is unaffected by excessive heat and of exceptional durability—a plug that gives a quick start and adds **\$1.25** power to the Engine. Retail price . . . . .

Porcelain Plug is specially designed for the FORD engine. It has Solid Brass body, 1/2-in. gas thread, is clean to handle, will not rust, fits the special FORD spanner, is insulated with finest porcelain and is detachable for cleansing. Retail price **90c**

Get on to the APOLLO PLUG proposition and you'll do big business in selling plugs. We can give prompt shipment of all models and supply you with posters, showcards and advertising literature. Write us for trade terms and full particulars of our models.

### APOLLO PLUG MFG. CO.

Canadian Head Office:

135 King St. West, Toronto. Factory: Birmingham, Eng.

Plugs for all engines



APOLLO  
No. 1  
Super  
Mica  
Plug



APOLLO  
Special



APOLLO  
L.C.B.  
Special  
FORD  
Plug

Overtime  
Tractor  
Plug



# VETERAN TRUCKS

For Continuous Service and Reliability



Service is measured by the amount of time in which a certain mechanism will do a given amount of work with the least amount of trouble, which means minimum operating cost and is the principal item in which the truck operator should be interested. No matter how simple, quiet, light or what price the device may cost, sooner or later a change will be made to that which gives continuous service and reliability.

**EASTERN CANADA MOTOR TRUCK CO.**

HULL, Limited QUE.

**Commercial Cars Limited, Toronto**

Distributors for Western Ontario, Manitoba, Saskatchewan, and British Columbia



# Lister

POWER ON THE FARM

## Three Money-Makers for Lister Dealers and Their Customers

Now is a good time to push milking machines and power installation for the barn to help the man who has gone into winter dairying. The name "Lister" will give the dealer the backing he wants in preaching profit and efficiency to dairymen. Lister dairy farm machinery is world-famous for its British reliability. It is *thorough* both in general principles and in details of construction. The Lister Milker, the Lister Engine, and the Lister Grain Grinder will make new friends and customers for the dealer wherever they are installed.

### *The Lister Milker*

Built in a British factory throughout and built in the British way, you can recommend the Lister Milker to your customers with perfect confidence. The Lister Factory has been noted for the high character and quality of its dairy machinery for fifty years. We'll help you with literature and back you in every necessary way. Write to us for what you need to develop prospects.

### *The Lister Engine*

Every Lister Engine is built, assembled and tested in England. That's a good talking point with most customers, and it's a good point for dealers to remember themselves. It means an honest, well made, efficient engine. The Lister Gasoline Engine is shipped complete and ready to run. No extras. Everything is there. Write us if you have prospects in sight. We'll help you.

### *The Lister Grinder*

There is not a more profitable machine on a dairy farm than a Grain Grinder, and there is no more satisfactory grinder on the market than the Lister. You may safely guarantee it to do more work than any other grinder sold in Canada, while grinding just as fine. Tell your customers about the Lister guarantee. We'll take back any Lister Grinder that doesn't live up to your guarantee.

*Send for the Lister Booklets*

**R. A. Lister & Company (Canada) Limited**

58-60 Stewart Street, Toronto



You've Waited For This!

# Smash Go Engine Prices

**Gilson Creates a Sensation by Slashing Prices to Pre-War Levels on New Engine**

**N**OW'S your chance to jump in with the Gilson line and clear up a bunch of money. You've got dozens of prospects for engines. PRICE has been holding them back. Now you can sell them an engine at a price you haven't quoted since 1914—a price lower than the lowest on the market.

**DOWN GO PRICES—  
UP GOES QUALITY**

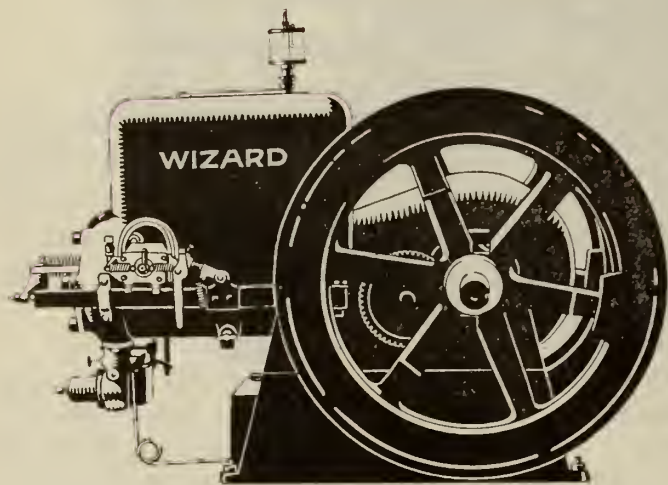

**T**HE "Wizard" line—the latest Gilson product—sets new standards of performance. Runs on cheap kerosene. Built-in magneto means easy starting and fuel economy. Throttle-governed. Big surplus power over rating—like all Gilson engines. Backed by a five-year guarantee. Though the price is lower than the lowest, you can safely invite comparison with any other engine at any price—for dependability, economical upkeep and service.

## Get the Cream of the Business

**Send This Coupon**

Gilson Mfg. Co., Limited

Gentlemen,—

I would like full facts on your dealers' proposition on the "Wizard" engine. Also send me the Gilson proposition on  Silos  Silo Fillers  Tractors  Threshers.

Name .....

Address .....

*Write for full facts at once. Prices are rock bottom now. Can't get lower. May be higher. A size for every need—1¾, 3½ and 6 H.P. You can offer FREE TRIAL and EASY TERMS. Who couldn't sell such an engine on such a basis? Get in with a running start.*

Advertising now appearing in all leading publications. Demand is pouring in. Be wise—and act now. Be the first in your territory to quote pre-war prices. Send a postcard at once.

**GILSON** Mfg. Co, 9618 York Street, Guelph  
 Limited 325 Elgin Ave., Winnipeg



Dealers who sell John Deere Equipment are bound to become firmly established

## In a Highly Profitable Business

John Deere Equipment is sold through John Deere Dealers only. You can take any piece of machinery in the John Deere line, compare it point for point with other makes of machinery and John Deere will sell on its merits.

There are so many exclusive features—so many points of superiority in the John Deere line, that your sales effort is reduced to a minimum. Demonstrations of John Deere equipment will back up all that you claim for it. Satisfy yourself: study the selling point of the John Deere line in comparison with other makes and you will readily see why it is most profitable for farmers to buy John Deere machinery—and for you to sell it.

Every piece of John Deere machinery has established a world-wide reputation for absolute dependability, durability, ease of handling and labor-saving ability. You have a wealth of prestige back of you when you sell the John Deere line.

The John Deere dealer proposition is decidedly interesting, liberal and highly profitable. It enables you, as a dealer, to take full advantage of your business individuality and initiative—to get the utmost out of your investment and to capitalize on your sales ability.

The John Deere policy has been and is to extend every possible factor of co-operation to John Deere dealers—to help them build a substantial business with real profit to themselves. The interests of the John Deere dealers are identical with our own.

*We want live dealers everywhere. Get in touch with us immediately and investigate our 1921 contract and sales proposition. John Deere will go farthest in helping you to increase your yearly income.*

### "QUALITY LINES" OF FARM IMPLEMENTS

John Deere Low-Down Manure Spreader  
 John Deere-Dain left-hand Side Delivery Rakes  
 John Deere-Dain rake-bar Hay-Loader  
 John Deere-Dain Sulky-Rake  
 John Deere-Dain vertical-lift Mowers  
 John Deere-Van-Brunt Plain Grain Drills  
 John Deere-Van-Brunt Fertilizer Drills  
 John Deere-Van-Brunt One-Horse Drills  
 John Deere-Van-Brunt Lime and Fertilizer Sowers  
 John Deere No. 999 Corn Planters  
 John Deere Cultivators  
 John Deere Scufflers  
 John Deere Smoothing Harrows  
 John Deere Spring Tooth Harrows  
 John Deere Disc Harrows  
(Horse or Tractor)  
 John Deere Field Cultivators  
 John Deere Beet Tools  
(Planters, Cultivators, Pullers)  
 Hoover Potato Machinery  
(Planters, Sorters, Cutters, Diggers)  
 "Reliance" Potato and Field Sprayers  
 "Waterloo Boy" Kerosene Engines  
 John Deere Walking Plows  
 John Deere One-Way Plows  
 New Deere Sulkeys and Gangs  
 John Deere Contractors' Plows  
 John Deere Tractor Plows

# The John Deere Manufacturing Co., Ltd.

Welland



Ontario



# In the Wake of the Master Plowman



1. Part of the line of manufacturers' tents at the Hamilton plowing match. 2. Watching the sod plowing at Hamilton. 3. Keen interest was displayed in the finish of the horse-plowing at the St. Anne's match. 4. The crown set up by Wm. Nussey, first prize plowman, with plain plows, at St. Anne's. 5. The finish made by Ewen McLennan in the boys' class at St. Anne's. 6. Chief Johnson, President of the Ohswekin Plowmen's Association; J. Lockie Wilson, Secretary and Managing Director of the Ontario Plowmen's Association, and R. H. Abraham, snapped in front of the headquarters' tent at Hamilton. 7. An excellent strike-out made with a tractor plow. 8. Operator H. B. Smith and the machines with which he won the manufacturers' contest at St. Anne's—Cletrac and 3-bottom Oliver. 9. James Paye, of Niagara-on-the-Lake, winner in the open class at Hamilton. His plowing does not show up in the picture as it was badly tramped by enthusiastic spectators.



# CANADIAN MOTOR, TRACTOR AND IMPLEMENT TRADE JOURNAL

Volume 2

TORONTO, NOVEMBER, 1920

Number 11

## Tractors Perform at Macdonald College

### 10,000 Enthusiasts Watch the Tractor Plow the "Stubborn Glebe"

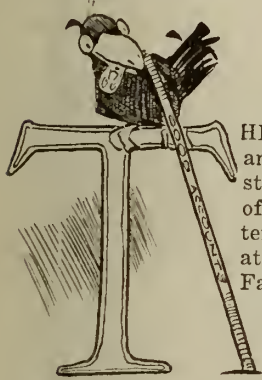

THE second annual plowing match and farm machinery demonstration held under the auspices of the Eastern Ontario and Western Quebec Plowmen's Association at Macdonald College Farm, St. Anne de Bellevue, Que., Oct. 12-14, was, from every standpoint, an unqualified success. The site chosen for the match, from the point of beauty was ideal, and the condition of the soil as a whole was conducive to good plowing.

For the first two days the demonstration was graced by midsummer weather, and in spite of the fact that it broke on the final day and considerable rain fell the attendance was good. The officials estimated that between 8,000 and 10,000 people attended.

Farmers and dealers in power farming apparatus formed the bulk of the attendance.

The pleasant weather conditions prevailing during the first two days brought out a considerable number of the ladies who appeared to take as much interest in the demonstrations as the men.

Two notable features of the demonstration this year were the competition for tractor manufacturers and the large display of tractors on belt work. The latter feature was a welcome sign that the manufacturers realise the farmer is sold on the tractor as a plowing utility, and appreciate the fact that both the dealer and farmer require to be shown the tractor is equally efficient on belt work, and can be used 365 days in the year.

THE Fordson power farming exhibit was a comprehensive affair and altogether worthy of praise. It showed the tractor hitched up to every conceivable kind of machinery used on the farm; and not only that, it showed these machines being operated and actually doing the work. This exhibit attracted huge crowds each day. It was evident that the farmer is very much interested in this phase of tractor operation. He got his eyes filled. He saw and critically inspected tractors operating a pump giving a 3-inch flow, a circular saw cutting logs, a threshing machine threshing grain, an ensilage cutter and silo filler, etc., etc. In connection with this display farm trucks were used for hauling corn to the silo filler. After it was cut and blown through the silo filler it was loaded on to a truck and hauled to the College Farm barns to be used for feed. Thus the circle of power farming was completed.

The advantage of such a demonstration to the whole industry cannot be overestimated. Manufacturers, dealers and farmers were brought together, not for a talk, but to show and to be shown. And it is this showing that is going to put power farming on the map.

The manufacturers represented included the following:

T. E. Bissell and Co., Ltd., Elora, Ont.—Disk harrow tractor hitches.

The Cleveland Tractor Company, of Canada, Ltd., Windsor, Ont.—Cletrac tractors.

The Canadian Fairbanks-Morse Co., Ltd., Montreal branch—Wallis tractors, farm lighting plants, water systems and gas engines.

Ford Motor Company, of Canada, Ltd., 119-139 Laurier Ave. E., Montreal, Que.—Fordson tractors, Ford trucks and automobiles.

The Land Drainage Excavator Co., Ltd., 45 Chancery Lane, London, England—Revolt Drain-Excavator.

The Goodyear Tire and Rubber Company, of Canada, Limited—Klingtite belts.

The Moody and Sons Co., Terrebonne, Que.—Threshing machines.

Chase Tractors Corporation, Limited, Toronto—Tractors.

Cockshutt Plow Co., Limited, Brantford, Ont.—Tractor plows.

The De Laval Co., Limited, Montreal branch—Cream separators and milking machines.

The Renfrew Machinery Co., Limited, Montreal branch—Tractors, engines and scales.

The Macartney Milking Machine Co.—Milking machines.

Imperial Oil Co., Limited, Montreal branch—Gasoline and oils.

Sawyer-Massey, Hamilton, Ont.—Tractors.

Shinn Mfg. Co., Guelph, Ont.—Lightning rods.

Perfection Stove Co., of Canada, Limited.—Stoves.

THE first day of the plowing match was merely setting up day for the tractor and machinery firms. The second day, Wednesday, saw the real work begun. The most important feature of this day was the competition for tractor manufacturers. This is the first time that such a competition has been staged in Canada. Professor W. H. Day, formerly of the O.A.C., and now with the Shinn Mfg. Co., field manager for the tractor competitions, prepared the tests. The contestants were rated on oil used, fuel consumption, speed and quality of work. Thirty points were allowed for fuel consumption; thirty for

time, depth and evenness of furrow, and forty points for quality of work. The tractors participating in this contest were Cletrac, Fordson, Happy Farmer and Chase.

It is unfortunate there were not more entered for this class. Some tractor concerns from time to time have expressed their reluctance to participate in such competitions and demonstrations. It is difficult to determine just why they adopt this attitude. No doubt they have some good reasons for staying out but the dealer, farmer and interested spectator could give a dozen excellent reasons why they should come in and help to proclaim the gospel of power farming.

In a competition of this kind there are several things to be taken into consideration, and one cannot jump too quickly to conclusions. We have all seen an automobile, which everyone concedes is a first-class machine, fall down at some time much below its own ability. We all know that tires blow out, radiators leak, etc., etc. Accidents can also happen to tractors which will temporarily impair their efficiency. And perhaps such an accident may not occur again for months, if ever. So it is not wise to conclude that a tractor which happens to win to-day is superior to the other contestants. We don't wish to detract anything from the credit of the winner of this particular competition, we merely point out that luck enters very largely into a contest where combustion engines are concerned and the loser to-day may be the winner to-morrow. However in spite of that, we think such competition between manufacturers is a healthy sign and can only result in renewed interest in tractor design, manufacture and operation.

The manufacturers' contest lasted from 9 to 11.30 a.m. Three official observers followed each machine, checking up on depth of plowing, etc. The farmers followed the contest very closely and only the strict policing of the course by the officials kept them from following the machines down the length of the field. When the results were given out it was found that the Cletrac, with a 3 bottom Oliver Plow, operated by H. B. Smith, demonstration agent, scored 90 points, the Fordson, with a 2 bottom Oliver, 82, Happy Farmer, with a 3 bottom Cockshutt, 76, and a Chase, with a 3 bottom Cockshutt, 65.

The score card read as follows:

Exhibitors	Area, depth			Total
	Quality	and time	Fuel	
Possible score ..	40	30	30	100
1. Cletrac .....	30	30	30	90
2. Fordson .....	35	27	20	82
3. Happy Farmer	27	27	22	76
4. Chase .....	28	21	16	65

While this competition was on farmers with horse drawn plows were busy in another field.

The plowing, all round, according to experts, was of a very high order. The tractor plowing, particularly, showed considerable advancement over previous demonstrations.



Revolt Drain Excavator, an English machine, performing at Macdonald College.



ON Wednesday afternoon tractor demonstrations were staged; plowing, disking and harrowing being carried on at a lively pace. Tractors were to be seen everywhere, on the roads, moving from field to field and even demonstrating their ability for trucking purposes.

On Thursday, October 14, starting at 9 a.m., farmers' tractor contest took place. This class was plowing in sod and open to bona fide farmers or farmers' helpers only. They could either operate their own or a borrowed machine. Farmers, or others, who had at any time operated a tractor for a manufacturing company at any public demonstration or competition were barred from this class. The tractors entered for this class comprised nearly all of the different makes used in Eastern Canada. It was unfortunate that the weather broke and several heavy showers of rain came down while the tractor and high-cutting plows were in operation. However, although their skins were wet, the contestants' enthusiasm was not dampened. The work done by all the competitors was exceptionally good and showed that the farmers were as capable of doing a first-class job and of operating their tractors as the companies' demonstrators. The winner in this class was Wm. Scott, of Macdonald College Farm, with R. B. Ness, of Howick, a close second. Both men used Fordsons and handled their tractors and plows skilfully. The crown both men set up was very good, and the finish and straightness of their furrow would take some beating.

ON the evening of October 14 a banquet was held in Macdonald College when several speeches were made and the prizes were awarded to the successful competitors. Dr. Harrison, President of Macdonald College, gave a short address of welcome after which the chair was taken by John Hay, M.P.P., of Lachute, President of the Eastern Ontario and Western Quebec Plowmen's Association. Speeches were made by Dr. Grisdale, of Ottawa, Dr. Grenier, Deputy Minister of Agriculture for Quebec, and W. B. Roadhouse who brought greetings from Ontario. Professor Barton, of Macdonald College, distributed the prizes. L. C. McOuat, Secretary of the Plowmen's Associa-

tion, deserves the highest praise for the manner in which he, and the executives he had gathered around him, conducted the match. Everything possible was done for the comfort and convenience of competitors and visitors. There was no confusion anywhere and everything went off as scheduled.

One of the busiest places and to some of us one of the most important was the refreshment tent where one could get a good "square" for 75 cents. Besides getting the "square" a good scratch was thrown in as there were thousands of flies which resented very much being disturbed from gorging themselves on hamburger steak.

The farmer these days in place of hitching up old "Dobbin" to the democrat and driving the family to the plowing match as in years gone by, comes in his motor car. As the cars arrived on the grounds an official directed the motorists where to park. Hundreds of cars were to be seen parked side by side in a field adjacent to the demonstration grounds. This official also directed the traffic to and from the grounds without a hitch. The majority of the visiting dealers and farmers were from Quebec, although a fair representation from Ontario attended.

As a business-getter the demonstration was a big success. Every exhibitor spoken to expressed satisfaction at the interest shown, the amount of sales made and the long count of prospects listed. One of the tractor exhibitors said that every tractor shown in their exhibit had been sold, either to a farmer or to a dealer.

An interesting exhibit was the Revolt drain-excavator displayed by an English concern. This machine created quite a sensation at Darlington, England, last year. It is made by the Land Drainage Excavator Co., Ltd., of London. This company have just brought their machine into Canada and intend to dispose of the manufacturing and selling rights to a Canadian or American concern. The machine can be either tractor or horse-drawn and will dig a ditch several feet in short notice.

TWO very noticeable features of the plowing match were the absence of quacks and fakirs and the manner in which the officials controlled the crowd,

yet keeping everybody in good humor. In the case of both tractor and horse plowing nobody, except the authorized officials, was allowed to follow the plowmen or walk on the plowed furrows. It was no cinch of a job at first to get the crowd to stay at the scratch mark but in a very short time everybody saw the justice of the restrictions and the work of the officials became easier. These arrangements made it easier for competitors and gave them a chance to perform their best work. The officers and directors of the Eastern Ontario and Western Quebec Plowmen's Association are as follows:

Hon. President.—Hon. J. E. Caron, Minister of Agriculture, Quebec.

Hon. Vice-Presidents.—Dr. J. A. Grenier, Deputy Minister of Agriculture, Quebec; Dr. F. C. Harrison, Principal of Macdonald College, Quebec; Prof. E. S. Archibald, Director, Experimental Farms, Ottawa; J. S. A. Ashby, Lachine, Que.; Hon. N. Garneau, Quebec.

President.—John Hay, M.P.P., Lachute, Que.

First vice-president.—J. Lafontaine, Berthier, Que.

Second vice-president.—J. P. Brady, Bassin du Lievre.

Third vice-president.—O. D. Casselman, P. I. P., Chesterville, Ont.

Directors.—J. E. Arnold, Grenville, Que.; Robert Todd, St. Andrews East, Que.; W. L. Chauvin, Angers, Que.; E. N. Blondin, Huntingdon, Que.; J. W. Logan, Howick, Que.; A. T. Charron, St. Hyacinthe, Que.; J. A. McClary, Lennoxville, Que.; A. Dawes, Lachine, Que.; H. L. Tarte, "La Patrie," Montreal; Donat Raymond, Montreal; W. R. Beach, Cowansville, Que.; J. N. Ponton, Montreal; Prof. R. Summerby, Macdonald College, Que.

Special directors.—R. B. Faith, Ottawa; F. C. Nunnick, Ottawa; T. A. Poole, Perth, Ont.; J. W. Nelson, Ottawa; A. A. McClennan, Lancaster, Ont.; A. F. Hunter, Vankleek Hill, Ont.; B. Rothwell, Ottawa.

Managing Director.—Prof. H. Barton, Macdonald College, Que.

Treasurer.—E. A. Lods, Macdonald College, Que. Secretary.—L. C. McOuat, Macdonald College, Que.

# Hamilton Plowing Match Attracts Crowd

## The International Tractor Demonstration Indicates that Canadian Farmers are Enthusiastic in Their Interest in Power Farming

"WE drew together these tractors and plowmen in order to acquaint farmers generally with the working efficiency of the various machines. We have many fine tractors and good plows on the market. Too often the farmer is humbugged by an agent who magnifies some minor point concerning which his firm has little knowledge of his sales methods. In order to place farmers on a basis of discussing intelligently and seeing accurately how real things are done, we call out to the various manufacturers to enter the lists. I am well pleased with the Hamilton match. It is the best we have had."

Thus does J. Lockie Wilson, secretary and managing director of the international plowing match, tractor and farm machinery demonstration held at Hamilton, October 20 to 22, sum up his opinion of the usefulness of such demonstrations as an educational medium for dealers and farmers, and as an opportunity for manufacturers to demonstrate their machines before their dealers and potential customers.

Ideal autumn weather favored the match, which was held at the Ontario Hospital Farm, on the Mountain. This year's match, in the opinion of Mr. Wilson, has been the most successful, from every standpoint, ever held in the eight years of the Ontario Plowmen's Association's history under whose auspices it was held.

Practically every make of tractor sold in Eastern Canada was represented on the grounds. Their chugging was heard everywhere dominating all other sounds. As the Ontario Plowmen's Association in Western and Central Ontario is older and better established than its sister organization in

Eastern Ontario and Western Quebec it was in a better position to stage a large demonstration. It was certainly a match of gigantic proportions, and dealers and farmers from all over Ontario flocked to it in thousands. Like the Quebec match dealers and farmers formed the bulk of the attendance.

### Interest in Power Farming

The power farming display was even larger than the fine one staged at Macdonald College, and was, if possible, more realistic of actual farming conditions. It was a great feature and a big drawing card. Hundreds of dealers and farmers and farmers' wives hovered around the various exhibits, and were loud in their expression of appreciation of the manufacturers' efforts to speed up farming operations and make the farm house a pleasanter place to live in. The exhibits covered all labor saving machinery and equipment used on the farm and in the home.

The following is a list of exhibitors at the Hamilton demonstration:

Cockshutt Plow Co., Limited, Brantford, Ont.—Tractor plows.

The Canadian Fairbanks-Morse Co., Ltd., Toronto.—Tractors, electric plants, water systems and gas engines.

The Cleveland Tractor Company, of Canada, Ltd., Windsor, Ont.—Cletrac tractors.

Chase Tractors Corporation, Limited, Toronto.—Tractors.

Beaver Motor Truck Corporation, Limited, Hamilton, Ont.—Beaver trucks.

Union Petroleum Co.—Gasoline and oils.

Frost Fence Co., Hamilton, Ont.—Steel fences and gates.

Reo Sales Co., Hamilton, Ont.—Reo trucks.

Imperial Oil Co.—Gasoline and oils.

Canadian Oil Co.—Gasoline and oils.

Delco Light.—Electric lighting plants.

The John Deere Manufacturing Co., Limited, Weland, Ont.—Kerosene engines and tractor machinery.

The Samson Tractor Company, of Canada, Limited.—Tractors.

Sawyer-Massey, Hamilton, Ont.—Tractors.

Canadian Potato Machinery Co., Limited, Galt, Ont.—Potato diggers.

Nicholson Lumber Co., Burlington, Ont.—Silos.

Dundas Garage and Sales Co., Dundas, Ont.—Moline tractor.

Foamite Firefoam Co., New York.—Fire extinguishing apparatus.

A. Hemme, Sons and Co., Limited, Elmira, Ont.—Weed destroying and root seeders.

Canadian Aspinwall Co., Guelph, Ont.—Potato diggers.

Dominion Steel Products Co., Limited, Brantford, Ont.—Dominion Light.

Willatt, Brantford, Ont.—Patent silo roofing.

The Robert Bell Engine and Thresher Co.—Waterloo Boy tractors.

Burlington Steel Products Co.—Steel fence posts.

Monarch Tractors Co., Brantford, Ont.—Monarch tractors.

The Renfrew Machinery Co., Renfrew, Ont.—Tractors, engines and scales.

Goodison Thresher Co., Sarnia.—Hart-Parr tractors.

Ford Motor Company, of Canada, Ltd.—Fordson tractors, trucks and automobiles.



# Tractors as Seen at St. Anne and Hamilton



1 A Samson plowing with an Oliver. 2. A Titan on the job with a John Deere plow. 3. This shows the extent of the Fordson power farming display. 4. The crown that the Cletrac set up at St. Anne de Bellevue. 5. The Fordson finish at Macdonald College—not much wrong with that. 6. A Massey-Harris tractor plowing with a 3-bottom Massey-Harris plow. 7. Giving some instructions to the Hart-Parr operator. 8. A Sawyer-Massey, with a 3-bottom Cockshutt, starting another furrow. 9. A Waterloo Boy with a John Deere plow posing for M.T.I.



Alderson Bros., Hamilton, Ont.—Gray-Dort cars. National Steel Car Co., Hamilton, Ont.—National motor trucks.

Massey-Harris—Tractors and tractor plows. T. E. Bissell and Co., Limited, Elora, Ont.—Disk harrow tractor hitches.

The Land Drainage Excavator Co., Limited, 45 Chancery Lane, London, England.—Revolt drain-excavator.

The first day, Oct. 20, was given up entirely to tractor demonstrations. As a rule the opening day of an event such as this is merely setting up day. But the farmers and dealers and interested spectators from Ontario decided to see this thing right, and started in good and early to enjoy themselves.

That they thoroughly enjoyed themselves was evident on every hand. One spectator was heard to say on the second day: "I got here right early yesterday and followed these tractors all over the fields and I intend to stay all day today and come again to-morrow." Owing to the long spell of dry weather the soil was dry and hard; but, notwithstanding, some very fine work was performed.

The second day saw the horse-drawn plows in action. There were classes in both sod and stubble and for both plain and high cutting plows. A special feature of the match was the large entry of the Indians of Ontario reserves. Several classes were for Indians only and they were as keenly contested as any on the field. Chief Johnson, president of the Ohswekin Plowmen's Association, was present in his chief's full regalia, lending a picturesque touch to the scene.

The tractors were also busy on this day, plowing and disking and performing on belt work. In the power farming display a tractor was to be seen operating a silo filler, filling a real silo. And, as in the case at Macdonald College, real corn was cut and filled into the silo. The versatility of the tractor was emphasized very clearly. One could have spent the best part of a day watching the tractor in its various operations, and seeing something new all the time.

That the farmers have caught the vision of power farming goes without saying. Such demonstrations as those held at Macdonald College and Hamilton have helped to open the farmer's eyes so that he can catch the vision. The task of the tractor dealer is getting easier all the time. The missionary work has been done. It is now up to the dealer to see that the vision materializes.

#### The Tractor Contests

Two tractor contests were staged on the final day. One was between farmers and the other was a free-for-all, open both to manufacturers and farmers. Both drew a large number of entries, one 18 and the other 19. More than a dozen different makes of tractors were represented and entries were received from all parts of Ontario, Quebec and even from New York State.

In the open class, which developed practically into a manufacturers' class, the following tractors were being operated: Samson, Titan, Waterloo Boy, Massey-Harris, Cletrac, Fordson, Wallis, Avery, Hart-Parr, Monarch and Happy Farmer. There was no contest where the judging was based on fuel consumption, oil used, speed, depth of furrow and quality of work as at Macdonald College. The results were as follows:

1. Clark Young, Milliken, with a Fordson and a Cockshutt plow.
2. Bert Kennedy, Agincourt, with a Fordson and a Cockshutt plow.
3. J. W. Kennedy, Agincourt, with a Fordson drawing a Cockshutt plow.

The farmers' tractor class was very keenly contested. There was an unfortunate misunderstanding by the judges which prevented many of the contestants finishing in time. However the work performed was of a high order and speaks well for the future of power farming in Canada. The winners in this class were as follows:

1. L. A. Kennedy, Agincourt, with a Fordson.
2. B. Brown, Ryckman's Corners, with a Cletrac.

3. Jacob Lewis (Indian), Wilsonville, with a Fordson.

The judges of the tractor events were Frank Weir, Agincourt; Norman Malcolm, Malton; William Hoster, Agincourt; and William Elliott, Galt.

Owing to the soil being extremely dry and hard the spectators who eagerly watched the tractors at work were obliged to do so in a cloud of dust. But what is a little dust to an enthusiast? It is estim-

9th " —W. H. Patterson.

10th " —Wm. Doherty.

11th " —G. B. Little.

12th " —T. A. Patterson.

13th " —Wm. Doherty.

Tractors—D. D. Gray, A. E. Wilson, J. Lockie Wilson and W. S. MacFarlane.

Local Committee at Hamilton—Lieut.-Col. F. P. Healey, Secretary of Hamilton Board of Trade; J. A. McIntosh; Reeve T. J. Mahony, Saltfleet; Warden J. E. Peart and W. G. Marritt, agricultural representative.

The demonstration was a very successful undertaking and reflects the utmost credit on the officials for their careful and efficient management. Meals were provided on the grounds at reasonable rates by the ladies of different associations in and around Hamilton. Perhaps one of the best indications of the show's success is found in the favorable comment of the exhibitors. All agreed, as a business getter, it was the best ever. We even heard of two men from as far away as Porto Rico who were on the grounds checking up the different exhibits and making numerous enquiries. Considerable interest was shown by dealers and farmers in the farm lighting exhibits. There were three exhibitors of farm electric plants and each drew its quota of enquirers from the big crowd. Opinion was evenly divided as to whether

the dealer or the farmer had the greatest interest in the exhibits. One thing is sure the dealers who were present will go back to their territories with the determination to cash in on the interest created in power farming by the two splendid demonstrations just staged. The farmer too will be easier to sell because of what he saw.

The demonstration was brought to a close by a banquet held at the Royal Connaught Hotel under the auspices of the Hamilton Board of Trade. Reeve T. J. Mahoney, of Saltfleet, acted as chairman. Two members of the Ontario Cabinet—Hon. F. C. Nixon and Hon. F. C. Biggs—were present and delivered short addresses. The City of Hamilton was represented by Major Booker. The prediction that power farming was very soon going to revolutionize agriculture in Ontario was made by Hon. F. C. Nixon, Provincial Treasurer. He thought it reasonable that the Government should give the association a grant and remarked that the late Government had promised to take the matter into its consideration. Hon. F. C. Biggs spoke on good roads to develop Ontario's vast acreage. To his mind the transportation problem in Ontario had become so serious that a network of good roads over the entire part of the Province offered the only solution. "We appreciate," he concluded, "that the farmer needs a system of good roads that will ensure rapid delivery of his products to market. I may say we are striving to give all interests in Ontario better roads."



Clark Young, of Milliken, Ont., in action at Hamilton. He won the open tractor plowing event with a Fordson and two-bottom Cockshutt.

ated that fifty tractors in all were on the grounds taking part in the contests and demonstration.

People flocked to the match in thousands. Some came on foot, some in automobiles and some in trucks and buggies. Over one thousand automobiles parked in an adjoining field were counted at one time. Attendance at the match each day averaged about 16,000. Among the many prominent public men and agriculturists in attendance were: Hon. F. C. Biggs, T. J. Stewart, M.P., W. A. Crockett, M.L.A., Frederick G. Sandy, M.L.A., (Victoria), and W. B. Roadhouse, Deputy Minister of Agriculture.

The officers of the Ontario Plowmen's Association in charge of the big show, are as follows:

- President—A. E. Wilson.
- First Vice-President—D. D. Gray.
- Second Vice-President—A. B. Rose.
- Treasurer—F. P. Johnston, Toronto.
- Secretary and Managing Director—J. Lockie Wilson, Parliament Buildings, Toronto.

Directors in charge of various classes:

- 1st Class—W. C. Barrie.
- 2nd " —Frank Weir.
- 3rd " —A. B. Rose.
- 4th " —Cameron Walkington.
- 5th " —Fred Ough.
- 6th " —J. H. Hilborn.
- 7th " —R. H. Abraham.
- 8th " —Jas. McLean.



A view of some of the cars parked on the grounds at the Hospital Farm.



*In some future issues M. T. I. is planning to publish some special articles dealing with all phases of tire repairing. Tire repairing is a highly profitable business for the man who is fully qualified and equipped, and employs expert workmen. The present article describes briefly the opportunities in this business and gives some general information on the construction and repairing of tires.*

## Details in Tire Repairing

By F. H. SWEET

Moisture is absolutely detrimental to a repair, and there is no such thing as "moist heat," as the heat from a steam vulcanizer is sometimes called by repairmen who think that because a vulcanizing plate has steam behind it, the kind of heat is different than if it were produced by electricity, for instance.

Too high a temperature will overcure or burn a tube regardless of whether there is steam in connection with the vulcanizer or not. The correct temperature will vulcanize perfectly regardless of the heating medium that is used. In vulcanizing tubes, the repair is prepared in one of the ways described later. A piece of wax paper is laid over the repair and the repair placed on the flat tube plate. The waxed paper is merely to keep the sticky new rubber from adhering to the hot vulcanizer. A block of wood of suitable size is next placed over the tube and a clamp applied so as to give a good firm pressure. The tube is left on the vulcanizer for a length of time dependent on the size and thickness of the repair, and when removed and cooled, it ready for use. If repairs are properly prepared, there is no danger of the tube sticking together on the inside, because the inside of the tube is covered with bloom, or free sulphur, that will not incorporate into the repair.

**I**N the case of very large repairs, it is easy to avoid even the possibility of such trouble by placing a piece of paper inside of the tube to prevent the repair from touching the opposite side. The paper can do no harm if left inside. Clean the tube thoroughly with clean high test gasoline and coarse sandpaper, or a rasp, for at least an inch all around the puncture; then wipe off the dust with a cloth or waste moistened with gasoline. The success of all repairs is largely dependent on cleanliness. Commercial gasoline, as sold to-day, is likely to contain more or less oil, and, consequently, may even hinder a repair from sticking as it ought to. If gasoline that is clean and free from grease cannot be obtained, do the cleaning with sandpaper and let it go at that.

If gasoline is used, let it evaporate and then apply vulcanizing cement to the edges of the hole and spread a thin layer around the hole to cover a space as large as a silver dollar. When this has dried for a few minutes, apply a second coat of cement over the first and let it dry thoroughly.

If the hole is only a very small one, push a little piece of raw rubber into it and then take another piece as large as a quarter and place it over the puncture. Cover with wax paper and put on the vulcanizer for 15 minutes at a temperature of 265 degrees F.

Trim the ragged edges of the rubber with shears so as to leave a slit in the tube about a quarter of an inch wide. Wash and clean the tube inside and out for an inch or more around the cut, using clean gasoline. Roughen the cleaned surface with a rasp. Coat with two layers of cement, allowing each to dry separately.

Insert into the hole an inside patch of one-side cured rubber by folding and setting in place with pliers. The uncured side of the patch comes next to the hole in the tube, and the cured side prevents the repair from adhering to the opposite side of the tube. Next fill the cavity with strips of raw rubber, pressing each down firmly so that the edges of the raw rubber are stuck to the edges of the tube all the way round. Finally roll the repair lengthwise and crosswise with a stitcher, which is a small toothed wheel that is made to insure all of the repair being firmly united to the tube.

There is practically no limit either in length or

area to the size of repair that can be made by this method and the finished repair will be as strong as the rest of the tube. If the repair happens to extend partly around the tube, it is prepared all at once, although the vulcanizing process may require two or three settings in order to get all of the repair into contact with the vulcanizer.

**T**HE only way to figure whether or not a tire is full value for the money is to consider the number of miles it will run and give good service. For this reason it is obvious that it does not pay to buy a tire recommended only by its cheapness, because it is natural that with the current prices of the best tire fabric that a certain limit is placed upon the manufacturer by the high cost of his materials. The tire in most common use to-day is the fabric tire, which has a canvas of 17 1-4-ounce duck, close woven; but this construction is gradually being replaced by the cord type, which has several advantages. As a matter of fact, although the cord tires are more expensive, the increased mileage gained by the use of cord tires must be considered in their purchase. Full value for the money is given in the well known makes of tires, whether fabric or cord types are purchased. Where value is not given, however, is in the tires which are made up of shoddy material for fabric and have too large a percentage of reclaimed or scrap rubber.

The very best quality of rubber must be used for tires. You can easily find this out for yourself by getting quotations of the scrap buyers on the scrap from different sources. The scrap from the rubber tire is always valued much higher than other scrap rubber. However, the scrap from a tire would not be suitable to make the next set of rubber tires. That is, each time the rubber is cured it goes down grade until finally it ends in such condition as the rubber used for overshoes. This rubber has not the toughness or elasticity required for tire use, and would soon wear away under the hard stresses imposed upon it by travelling over the roads. Not only does the rubber wear away quickly on the tire which is built particularly for cheapness, and the fabric go to pieces because it has not the strength of the high quality product required, but the tires themselves, through their higher rolling resistance, use the power of the engine. In other words, with good tires you get more miles to the gallon of gasoline than you do with poor tires. This last has been proven over and over again. The reason for the loss in power is due to the internal friction in the tire. This causes some of the energy to be wasted in the form of heat, and naturally the heat itself does not do anything to prolong the life of the tire.

A tire which has not been as carefully made as it might be has more internal friction, due to the lack of cohesion between the various layers of fabric, and, furthermore, there is less give to the rubber and less ability to stand flexure without weakening.

**T**HE tire comprises two definite parts, the rubber tread and the canvas base or carcass. It is the canvas base that does the actual work of the tire, the tread being used merely to protect the carcass from water, bruises and cuts. This means that it is vitally necessary to keep the tread always intact. Cuts must be plugged and vulcanized as soon as they are noticed. Of course, in time, even with the best care, the rubber tread wears down and the canvas is exposed and inevitably the complete wrecking of the tire follows. Retreading is effective

Continued on page 40



# CANADIAN MOTOR, TRACTOR AND IMPLEMENT TRADE JOURNAL

Published on the fifth of each month by

The MacLean Publishing Co., Limited  
TORONTO, MONTREAL, WINNIPEG

JOHN BAYNE MACLEAN,  
President.

H. T. HUNTER,  
Vice-President.

H. V. TYRRELL, General Manager.

LONDON, ENG., THE MACLEAN COMPANY, OF GREAT  
BRITAIN, LTD., 88 FLEET STREET, E.C.

BRANCH OFFICES: Montreal, Southam Building, 128 Bleury  
Street; Winnipeg, 1103 Union Trust Building; Vancouver,  
314 Carter-Cotton Bldg., 198 Hastings St. W.; New York,  
Room 620, 1133 Broadway; Chicago, 405-6 Transportation  
Bldg.; Boston, 734 Old South Building.

SUBSCRIPTION PRICE—\$2.00 A YEAR.

OFFICE OF PUBLICATION—143-153 University Ave., Toronto.

Vol. 2 TORONTO, NOVEMBER, 1920 No. 11

## The Tractor Demonstrations

THE two tractor and farm machinery demonstrations just held at Macdonald College, St. Anne de Bellevue, Quebec, and at the Hospital Farm, Hamilton, Ontario, were notable successes. At both shows there were new features which make them unique in the history of such demonstrations in Canada. We refer to the large display of machinery operated by the tractor on the belt and the contest at Macdonald College for tractor manufacturers and the open class at Hamilton.

The farmer is sold long ago on the tractor as a plowing utility, and, judging by his work in the tractor contests, has mastered the art of operation and can plow a furrow which any man may be proud of. He hasn't yet quite grasped the scope of the tractor on belt work and all such demonstrations as were staged at these shows are to be welcomed and given the "come again" for they will surely establish the tractor as a universal utility.

The dealer who sells tractors can also do his part in this particular field. He can stage his own demonstration to his own prospects at their own doors and at the proper time. Many tractor dealers are demonstrating and increasing their sales thereby. In the winter when the dealer is not so busy and when the farmer has more time on his hands a tractor demonstration could be staged at very little expense by using a farmer's tractor for cutting wood, clearing brush and all kinds of belt work. The farmer has these "chores" to do anyway and it could easily be arranged to have a number of the farmers of the surrounding district present to view the demonstration.

Many dealers are cashing in on such demonstrations. Why not you?

## Business As Usual

SOME people to-day are crying panic! Some people are always crying panic. Some people love a panic.

Cast your eyes over the business and industrial world to-day there would seem to be some justification for the attitude of the calamity howlers. Prices are coming down and because of that fact the buying public is holding off. Everybody is looking for further reductions and prophesying lower and still lower prices, hence the slowing up all round in buying.

The automobile business is slack to-day. Nobody denies it. Nobody wants to deny it. Admitted the public is not buying cars, what are we going to do about it? Are we going to sit back and say what's the use, or are we going to work out plans to overcome the difficulty? The first thing that will relieve the situation will be to get prices stabilized. The manufacturers could do a lot to clear the air if they would make a definite statement about prices and give guarantees. The dealer could help a lot by getting in touch with the manufacturers with a view to ascertaining probable cuts and getting guarantees. The need for transportation is as urgent as ever. People need cars; must have cars and cannot hold off for ever. A vigorous selling campaign coupled with judicious advertising and an emphatic statement about prices would go a long way to relieve the situation.



KEEP GOING!

"Motor World."

Let's all stand up, throw out our chests and shout Business as Usual!

There is no panic! We are not going to have a panic! The automotive business is again on the move and by the turn of the new year will be booming again.

Start selling!

Keep advertising! And lo, we are over the top.

## Motor Trucks and Country Bridges

IN view of the rapid increase in motor truck transportation in rural districts it is high time that the authorities looked into the question of the strength of the smaller country bridges and their ability to stand up under the increasing stresses to which they are being subjected by the weight and speed of motor truck traffic. Motor truck dealers should bring this very important matter to the notice of their local authorities to see if something cannot be done. Speaking in this connection the Scientific American says:

The benefits which have been conferred upon outlying farming communities by the rapid spread of the new system of freight transportation are so apparent, that it is certain, not only that rural motor truck service has come to stay, but that it will be enormously extended. Not only will the total freight carried grow rapidly, but there will be an inevitable increase in the size and speed of the individual trucks.

The art of road building has progressed to the

point at which we can construct roadbeds that will stand up under the most exacting service; but we question whether the bridge builder has kept pace with the road builder. It is certain that a careful survey of country bridges, made by competent bridge engineers, would discover hundreds of structures that are being stressed beyond the limits of safe and conservative practice.

In this connection we wish to draw attention to a most important element in bridge design, which only of late years has begun to receive the attention its importance demands. We refer to the question of impact. It is only now beginning to be realized that, even in steel bridges of the first magnitude, the difference between the stresses due to static as against dynamic effect may be enormous. A train moving very slowly across a bridge is one thing—the same train rushing across the structure at from forty to sixty miles an hour is quite another, and the increase of the stresses due to the hammer blow of the flying mass may conceivably be from fifty to one hundred per cent.

Undoubtedly the effects of impact are felt most severely by the floor system, and proof of this is seen in the fact that, in the cases where country bridges have given way, it has generally been the floor system (floor beams, stringers or planking) that has failed. Instances of the complete collapse of the trusses are comparatively rare.

We commend this subject of impact on highway bridges to the attention of road commissioners as one which calls for immediate action. Fast freight motor traffic, we repeat, has come to stay; our highways are equal to the new conditions, but too many of our highway bridges are not. They can be made so by a partial rebuilding at a cost that would not be excessive.

## Winter Overhauling

THE harvest practically over and the fall plowing almost completed, it is now drawing near the time for the farmer in nearly every district to withdraw his tractor from the field and lay it up for the winter. Now is the time to approach him about overhauling and to get him to order whatever repair parts he will be requiring when the spring work begins again. There is a big opportunity here for the repairman. Why not circularize your farmers with a view to getting them to overhaul now instead of waiting until the spring when the machines should be ready to commence operations?

## Tractors and Implement Prices

WITHOUT doubt, the present question of future prices on tractors and agricultural machinery is the most perplexing ever confronting these industries, says the Chilton Tractor Journal. Were conditions so nearly normal that the only consideration would be a matter of production costs, the answer would inevitably and logically be higher prices.

The preponderance of available evidence substantiates this belief. Several companies already have announced higher prices for 1921. Still others are guaranteeing their trade against declines. Only one manufacturer, possibly not affected to the same extent by general conditions as others in the industry, has announced a lower price.

Judging from present conditions the only possible opportunity for a price decline is the remote possibility of something improbable happening in a decidedly abnormal business period. And even in this statement the two most important words are "remote" and "improbable."

Undoubtedly, much of the present price discussion has been precipitated by the action of a number of automobile manufacturers who have lowered their prices. There may be some considerations involved in their action which do not bear on the tractor industry. Motor car prices made a much greater advance during the war and post-war periods than did tractors; and many believe that the automobile market was nearing a point of saturation at prevalent prices.

Neither of these conditions prevails in the tractor industry. On the other hand, with the nation's population increasing and shifting to the cities, and with food imports increasing while food exports are shrinking, the demand for tractors is growing. The demand for tractors does not depend much upon price; tractors are sold on a basis of utility and performance.

## PRINCIPAL CONTENTS

Tractors Perform at Macdonald College . . . . .	5
Hamilton Plowing Match Attracts Crowd. . . . .	6 and 8
Tractors as Seen at St. Anne and Hamilton . . . . .	7
Details in Tire Repairing . . . . .	9
Editorial . . . . .	10
Trailers Reduce Truck Costs—Sell Them . . . . .	11
Dealers Should Preach Care of the Tractor . . . . .	12
Advertising for the Implement Dealer . . . . .	13
Rosenheim at Latonia . . . . .	14
Operating a Night Garage . . . . .	15
Selling Autos, Accessories and Implements . . . . .	16
An Improved Hay-cocking Machine . . . . .	18
Shop Notes for the Garage Man . . . . .	20
Automotive Accessories . . . . .	24, 26
The Inaccessibility of Some Tractors . . . . .	30
Service—or Service Plus . . . . .	34
Dairy and Household Supplies . . . . .	36



# Trailers Reduce Truck Costs—Sell Them

Instead of Selling an Over-size Truck for the Purpose of Accommodating Extraordinary Loads, the Salesman Should Sell Trailers for Normal Load Truck

WHEN the truck salesman steps into the office of a prospective customer he should immediately ask for an accurate description of the freight to be hauled by the truck which he wishes to sell. It would be even better for the salesman to know in advance the answer of this question because the character, the volume, and the diversity of the tonnage procurable should govern the size of the truck, the use of the trailers, and the amount of freight for return loads. If the salesman aims to satisfy the requirements of his client he must sell him a vehicle which will be most adapted in construction and economical operation to the transportation of his freight.

In a recent article published in the Motor, Tractor and Implement Trade Journal, the writer pointed out that the ability of freight to bear the cost of transportation by motor truck varies directly with its value per unit of weight and bulk. Highly valuable manufactured goods will usually bear a heavy truck rate, while light and bulky farm products of comparatively low value such as hay cannot, as a rule, be shipped profitably by truck.

To some extent this drawback can be overcome by varying the size of trucks and by the use of trailers. Fully loaded trucks of five-tons or seven-tons capacity can haul more cheaply per ton-mile than trucks of smaller capacity. It follows, therefore, that if it be necessary to haul by truck a light and bulky product, such as hay, it would probably be less expensive per ton-mile to use a large size truck.

AGAIN, it would be uneconomical for a rural truck operator to invest in a five-ton truck in order to be able to haul a maximum load or an abnormal load such as hay. If his normal load be three tons of perishable products or groceries he should use a three-ton truck. He could leave the consumer unsupplied with hay until its value rose high enough to make it profitable for him to haul hay on his three-ton truck. This simply means that the salesman should not sell a five-ton truck when a three-ton truck is sufficient to carry the normal load, because the additional cost of operating the larger truck must be added to the rate which would be charged if the three tons of freight had been hauled by a three-ton truck. The higher cost of operating a larger truck when a small truck would give as good service will place a truck operator at a disadvantage in competition, and this again will react against the salesman who sold the over-size truck. When the disappointed operator decides to buy a new truck he will go elsewhere for advice and equipment.

Instead of selling an over-size truck to a client for the purpose of accommodating extraordinary loads, the salesman should sell the truck most adapted to the normal load. In addition he might sell his client a trailer which would make it possible to haul either a maximum load or a bulky load of such freight as hay. The economy of using a trailer may be demonstrated by the following illustration:

A five-ton truck will haul ten tons of freight in two trips, while a two-ton truck will haul the same amount of freight in five trips. It would be more economical to use a five-ton truck to do the work. The saving in driver's wages would alone be significant. It matters not whether he drives a two-ton truck or a five-ton truck, he will be paid the same wages per hour. Suppose the five-ton truck can haul ten tons of freight in two hours and the two-ton truck can haul the same freight in five hours. If the driver is paid 50 cents per hour, the five-ton truck would save \$1.50 in this item of operating expense. Similar economies might be accomplished in other items.

Now by attaching a five-ton trailer to the five-ton truck the ten tons of freight might be hauled in one trip of one hour's duration. The saving in driver's

By DONALD R. COWAN



The Descent.

—Lecocq in the Portland (Ore.) "Telegram."

wages by using the truck with trailer attached would amount to 50 cents. Other items in the cost of truck transportation might also be reduced by the greater use of the trailer.

THE limiting factors, of course, are the pavement and grades of the roads and the tonnage procurable for carriage in both directions. The pavement of a road is more likely to bear a truck and trailer than a truck of their total capacity. This is because the load is spread over a greater area of pavement, and the trailer exerts no tractive effort on the road. A steep grade on the road is a very serious hindrance to the use of trailers, but, ordinarily, a good truck has sufficient power to haul its own load and a trailer of equal capacity on a well paved moderately graded road.

The greater use of trailers will enable those engaged in motor express to increase their loading capacity at a comparatively small additional ex-

pense. It will also enable them to haul maximum loads economically and to compete in the hauling of freight which otherwise could not be profitably hauled by the truck, or could be more profitably hauled by team or railway locomotive. There is a large field of usefulness for the trailer, but for the present, the dealer has passed it over in his zeal to sell trucks. A canvass of truck-users for the purpose of inducing them to increase their transportation facilities by the use of low-priced trailers might be a paying proposition, especially at the present time when large concerns will not make a large investment in trucks because of the uncertain business conditions. The increased sale of trailers would certainly help the truck dealer to meet his overhead expenses as long as the present depression continues in his business.

## Dealer Writes To M.T.I.

"I HAVE been reading the articles in your journal, written by the various machine men, many of which are very interesting. I was in the implement business for some time and although I am not trying to create a discussion would be pleased to give you my ideas along these lines.

"The art of soliciting trade and holding a customer is the first point I would like to discuss. When a prospect is being canvassed one of the main things is to be fair and above board, equal prices to all, according to the list you are supposed to use for the particular district you live in.

"My second point is, let there be no misunderstanding between you and your customer as to his machine or equipment. When you have sold a machine and a misunderstanding exists probably in regard to doubletrees, sheaf-carriers, wrenches, or such like it is good business on the part of the dealer to satisfy the customer by giving these to him, rather than get angry at his interpretation of the agreement and tell him you do not want his trade and order him out of the shop as is often done. I contend the courteous treatment always pays.

"My experience in the machine business and the practice I followed was to get the settlements for the machines upon delivery, in doing so it was necessary to send out forms. My custom was to obtain a settlement on delivery of the machine. This a customer will gladly do if you show him that you will promptly make any adjustments if they are required when the machine is started. These, I may say, are very rare if care is exercised in setting them up."

## Ontario Implement Dealers Organized

THE need for an implement dealers' organization in Ontario has long been felt. M.T.I. has been talking and preaching organization for months and has published articles on the subject. The Ontario Implement Dealers' Association is now an established fact. At a meeting held at the King Edward Hotel, Toronto, on the night of Oct. 15th, the organization was formed. There was a good representation of dealers from all over Ontario and the association starts with a membership of fifty. The officers are as follows:

President—Llewellyn Hall, of Hall Bros., St. Catharines.

Vice-President—E. C. Hanson, Bothwell.

Secretary-Treasurer—Allan D. Gow, Toronto.

Directors—F. M. Clow, Kingston; D. H. Elliott, Comber; J. V. Dent, Bothwell; James Abbey, Cale-

donia; C. W. McKinley, Midland; George J. Lawson, Stouffville; George W. Smith, Toronto.

Addresses were given by the president and others, emphasizing the need for organization to help the dealer in his many problems.

Now then, Ontario dealers, get behind the new organization and help to boost the implement dealer to a better and surer standing. The problems are urgent and cannot be solved by the individual, organization alone will put them "over the top." The service question, the present low margins, the problem of repairs and the need for putting the business more nearly on a cash basis call for solution. It is to be hoped that every dealer in Ontario will become a member, not soon, but now. M.T.I. is behind the movement and will do everything in its power to further the cause.



# Dealers Should Preach Care of the Tractor

Teach Your Tractor Customers Importance of Giving Machines Proper Attention.  
Every Tractor Should be Overhauled During the Fall and Winter Months.  
Suitability of Lubricating Oil Important

A NEGLECTED tractor is more likely to be unsatisfactory than one which is properly cared for. No dealer can afford to have dissatisfied customers, and since the care of the machine plays so prominent a part in having a tractor prove profitable and satisfactory to the owner, it behooves the dealer to do what he can to have his customers give their machines the attention which they require.

By ARNOLD P. YERKES

Owners seem to form the opinion that the same will hold true with regard to the tractor.

In this they make a mistake. No tractor will develop full power and give satisfactory service unless it is lubricated with the proper grade of oil, and the

tractor he handles. A great many tractor owners make the mistake of using whatever kind of automobile or gas engine oil is most convenient. Some of them take the attitude that if the oil is good enough for use in their automobiles it is good enough for use in their tractors, while others take the word of a neighbor, or perhaps the man who has oil to sell, regarding the oil for their tractors. It is surprising that so many men are willing to carry on what often prove to be expensive experiments of this kind. The field men connected with the service department of large tractor concerns are constantly running across cases where complaint has been made concerning a tractor but where the entire cause of the trouble is poor oil or the wrong grade of oil.

Just recently a farmer who owned a two-cylinder kerosene tractor of a make that was giving very satisfactory service on thousands of farms complained that his machine would not develop his rated power and was unsatisfactory on that account. An expert was sent to investigate but after making a thorough examination of the machine could find nothing whatever wrong with the mechanism. He asked the farmer what brand of oil was being used and found it was one which was not included with those recommended by the manufacturer for that particular engine. He informed the farmer that the entire trouble was probably due to the wrong kind of oil, but the owner was skeptical.

The expert cut off the fuel supply at the carburetor and asked the farmer to notice how the engine "died." The momentum of the flywheel turned it over a number of times and then it came to a rather abrupt stop. It seemed to have a sort of jerky motion and was rather noisy.

The expert then drained the oil from the mechanical oiler and put in a new supply of a brand that the manufacturer recommended. After starting the motor and allowing it to run for some time in order to have the new oil reach all the parts and get them properly lubricated, the expert again cut off the fuel and asked the farmer to note how the engine "died."

This time it ran a great deal longer than before, and finally came up against compression, stopped, and rocked back and forth two or three times. It was obvious to anyone that the engine was running more quietly and smoothly. Furthermore, when put under load the motor developed ample power, which, after all, is the final test. The farmer was amazed at the difference, but admitted that the fault had been his and not the tractor's.

The dealer should impress upon his customers the



P. W. Edwards, Shaunavon, Sask., plowing with a Case 15-27 and Grand Detour Plow.

Neglect of farm machinery is so common that its importance is often overlooked. It is probably true that in the case of many farm machines exposure to the weather and lack of proper lubrication and general care does not do as much real damage as some people would have us believe. Farm machines which are drawn by horses do not have as heavy pressures nor as high speeds on their bearings as tractors and power-operated machines. This means that neglect will not damage them so severely and to this fact is doubtless due the lack of attention which is accorded them by a great many farmers.

In the case of the tractor, however, most of the bearings are transmitting considerable power and therefore work under comparatively heavy pressures. Furthermore, many of the bearings operate at rather high speeds. This means that they must be kept in first-class condition and well lubricated if they are to give satisfactory service, and the failure of any bearing or other part of the tractor at busy seasons nearly always means not only inconvenience, but loss.

A farmer who has been accustomed to allowing his binders, mowers, and other machines to stand exposed to the weather without seeing any serious deterioration from such usage is quite likely to think that he can treat his tractor in the same manner with no worse results. This is by no means the case, however. The bearings of most any machine which is exposed for several weeks in bad weather are almost sure to rust unless they have been well greased or oiled for the purpose of excluding moisture. A rusted bearing which transmits only a little power is not a particularly serious matter, but on a tractor it is quite likely to mean excessive wear; then a breakdown and unnecessary expense.

## Importance of Proper Lubrication

The importance of proper lubrication of the tractor can scarcely be over-emphasized. On most farm machines which are drawn by horses lubrication is not of paramount importance, although good lubrication does add to the life of such machines and lessens the draft considerably. But it is hard to see much difference in the results obtained from such machines from the use of different grades of oil, and from their experience with such machines a good many tractor

same grade of oil will not be satisfactory on all makes of tractors any more than one grade of oil will be satisfactory for all makes of automobiles. It is a rather common practice for tractor manufacturers to recommend certain brands of oil for use with their product. The dealer should make it his business to see that the farmer does not experiment with grades of oil other than those recommended. Such experiments are almost sure to cause trouble and the tractor often receives the blame instead of the oil. And when the tractor receives the blame the tractor owner generally places part of it on the shoulders of the dealer who sold him the machine.

## Use Oil Suitable for Tractor

It is to the dealer's interest to see that his customers use brands of oil which are suitable for the



The life of a machine is lengthened by proper care and lubrication.



fact that different makes of engines require different grades of oil, as they run at different temperatures, have different clearances between the piston and cylinder wall, run at different speeds, etc., and that oil which may work all right in one engine may not work at all satisfactorily in another.

In the case above referred to, the oil which the farmer had been using was probably too light or else a great deal of its viscosity was lost at high temperature, thus reducing its lubricating qualities and preventing it from properly sealing the space between the piston rings and the cylinder wall, hence allowing the burning gases to escape past the rings, as well as permitting some of the compressed air to escape before ignition took place. When one takes into consideration the functions which an engine oil should perform, it is no wonder that loss of power results from the use of poor oil, or oil of the wrong grade.

#### Overhauling Machinery

Overhauling farm machinery during the slack season so as to be sure to have it in first-class working order when needed has long been recognized as good practice—it is especially so with the tractor. Nearly every tractor should have a general overhauling during the fall or winter season. This may not always be necessary after the first season's work, but it will do no harm even in this case, and after the tractor has been used two or more years an annual overhauling is almost essential to insure satisfactory operation during the busy season.

Here again is an opportunity for the dealer to be

of assistance to his customers by urging them to go over their tractors or have some one else do it, replacing badly worn and broken parts, and putting everything in first-class shape for spring work. If the dealer maintains a repair department and has a repair man on his staff who can be of assistance to his customers in this work he will often find it to his advantage to offer to send the mechanic out to the farm while the work is being carried on, the farmer to pay all, a part, or none of the expense, as the dealer may see fit. Dealers have different viewpoints on these matters.

#### Precautions Against Freezing

Another point which dealers should impress upon their customers is the necessity for draining the cooling system of the tractor during cool weather, or else use a non-freezing solution. Every winter hundreds of gas engines are ruined or damaged by ice forming in the water jacket. Sometimes this is due to carelessness or forgetfulness on the part of the operator. In other cases the water freezes quicker than the operator thinks is possible and the damage is done before he realizes how quickly water in the cooling system of a gas engine will reach the freezing point.

If an engine is to be used only a few days during the winter, there is no need of going to the expense and trouble of using an anti-freezing solution. All that is necessary is to drain the cooling system completely as soon as a job is finished. Incidentally, this also permits putting some hot water in the cooling system when the engine is being started, which is

usually of considerable assistance in starting the engine when the weather is extremely cold.

A tractor which is equipped with a radiator for cooling the water should not be allowed to stand idle in cold weather more than a few minutes unless the radiator is drained or an anti-freezing solution used. Tractor radiators are designed for the purpose of cooling water rapidly and with the temperature around zero it requires only a few minutes to reduce the temperature of water from the boiling point to thirty-two degrees. If pure water is being used in the cooling system and the motor is stopped for a few minutes in real cold weather, the water in the radiator is quite likely to freeze and cause expensive damages.

Most engines which have cooling systems designed to keep the motor cool in the hottest weather will maintain a rather low temperature in very cold weather. Quite often the temperature will be too low to permit the tractor to develop full power and to operate efficiently. In such cases, it is advisable to cover part of the radiating surface, so as to keep the cooling water at a temperature in the neighborhood of 200 degrees Fahrenheit.

Some tractors have two or three petcocks which must be opened in order to drain the cooling system completely. The dealer should make it a point to see that his customers know how to drain the cooling systems of their tractors properly, as there have been many cases where an engine or radiator was injured by freezing simply because the operator was not aware that there was more than one drain cock.

# Advertising for the Implement Dealer

By B. J. PAULSON

YOU fellows who are implement dealers—how much money do you spend each year in local newspaper advertising? Will those of you who spend two hundred dollars or more for this purpose during the year please stand up so we can count noses? Great catfish!—is that all there are of you? We're almost surprised—almost, but not quite. You see, we know just about how you feel on the subject of advertising implements, in so far as you, personally, are concerned, taking it for granted that you are an average implement dealer and have the same viewpoint as most of your fellow dealers. Now confess—this is just about the way you figure it, isn't it?

"Let the implement manufacturer do the advertising. He's the fellow who has the money—and he gets more out of it than the dealer, anyway. Why should the dealer advertise? All he gets is a small commission or a narrow margin of profit. And by advertising the implements he sells isn't he advertising at the same time the big manufacturers? That would be fine business, wouldn't it—spending his good money to make money for the big fellows! Nothing doing! And anyway, advertising in the local paper is just like throwing away money—never gets results. Have to give the paper a little ad now and then just by way of charity—sort of a public duty to keep the paper alive! And on the top of all this—when in the world does an implement dealer have time to write advertisements except during seasons when no one is buying implements and advertising is a dead loss? And besides, what's the use of writing an advertisement when you haven't had enough experience at the job to be able to do it right? No—can't see it at all! Advertising may be all right for the manufacturers and dealers who have money to throw away but as a business proposition for the dealer who is selling only a nominal volume—well, it's simply out of the question and that's all there is to it!"

Is that the way you feel about implement advertising? Then listen, brother, for we may differ with you on one or two points—and perhaps we may be able to give you a broader perspective on certain phases of this advertising question. Let's try to analyze the matter and see who profits most by implement advertising.

#### Advantage of Local Advertising

You admit that it's a good thing for the implement manufacturer, don't you? And you're right; he thinks it is, too, or he wouldn't spend money in farm paper space that runs into many thousands of dollars during the course of a year. Yes, the im-

plement manufacturer has demonstrated very conclusively to his own satisfaction that advertising in the farm papers pays. But this advertising pays not only the manufacturer, but his dealers as well. His products are sold entirely through dealers and therefore every dealer receives a pro rata benefit from the manufacturer's advertising, although it isn't as readily apparent to the dealer as it is to the manufacturer, because the latter looks at the large cumulative volume coming from all his dealers while the dealer sees only his own individual volume.

But the manufacturer and dealer are getting only a fraction of the results they should derive from the manufacturer's advertising unless there is a tie-up between the manufacturer's advertising and the local dealer. Practically all of the leading implement manufacturers refer to their local dealers in their general farm paper advertising. They suggest that the farmer who is interested in the implement advertised visit the manufacturer's "nearby agent" or dealer. And this is where the rub comes in! How is the farmer going to know who that dealer is unless the dealer himself acquaints the farmer with the fact that he is handling the line advertised? Just suppose, for instance, that you are a farmer. You see a certain tractor advertised in your monthly farm journal. It looks good to you. You have been thinking for some time of buying a tractor—so you decide to look this tractor up the next time you happen to be in town. The manufacturer states in the advertisements that his "nearby agent" will be glad to explain the tractor fully. You don't bother writing the manufacturer to learn the name of that "nearby agent"—you never were much on writing letters, anyway. So you simply make a mental note of the name of the tractor and when you go to town you visit the implement dealer from whom you've been buying most of your farm machines and ask him what he knows about this particular tractor you saw advertised in your farm journal. Now, just suppose this dealer is selling a competitive tractor—and then imagine for yourself what he'd answer you when you asked about the tractor in which you are interested. Being an implement dealer, you know just what he'd say and do—and the chances are that you, in the role of Mr. Farmer, would soon have a very poor opinion of the tractor you thought so well of at the beginning—so poor an opinion, in fact, that you'd place an order for the tractor that this particular dealer happened to be selling.

Now, just where was the slip? The tractor manufacturer's advertisement just about had you sold but you innocently wandered into the lair of the competitive manufacturer's dealer—because you didn't just who was selling the tractor you wished to investigate.

On the other hand supposing you had read in your farm journal the advertisement about the tractor and, having made up your mind to learn more about it, pick up your local weekly paper and discover the same tractor advertised by one of your local dealers—what then? Why, you know immediately just where to go to see the tractor—and the dealer who advertised it is going to reap the full benefit of the manufacturer's advertisement. He has created the essential tie-up between himself and the manufacturer.

#### Dealer and Manufacturer Interdependent

The manufacturer, for various reasons, cannot advertise in every country weekly but by advertising in the farm journals having general circulation he is meeting the dealer's half way—bringing the prospect within hailing distance. Now, if the dealer doesn't do his part—meet the manufacturer half way and guide the prospect's footsteps to his store—the manufacturer's advertising is only fifty per cent. efficient for both manufacturer and dealer. The manufacturer advertises for mutual benefit—for the benefit of himself and his dealers. Why then should the dealer hesitate to advertise for mutual benefit?—for the benefit of himself and manufacturer? By refraining from advertising because of the fact that by so doing he will benefit the manufacturer is a case of cutting off his nose to spite his face. The manufacturer, of course, depends on the local dealer to sell his goods. But doesn't the dealer depend upon the manufacturer to just as great an extent? If it were not for the manufacturer the dealer wouldn't have any goods to sell. The manufacturer and dealer, therefore, are interdependent upon each other. And advertising is one of the success-building ties that should bind their interests firmly together. The country weekly newspaper supplies the mediums.

And the dealer who thinks advertising in his local paper is a waste of money—a matter of charity, if you will—has another guess coming ninety-nine times out of a hundred. The tangible results from newspaper advertising are hard to trace, but they are there, nevertheless. Many farmers are influenced, without really knowing it themselves, by advertisements in their weekly papers—but just because they don't mention the fact that they are gov-

Continued on page 40



# ROSENHEIM *at* LATONIA



Pinched (With Permission) From "Timken Magazine."  
Sketches by CLYDE E. DARR.



"WELL, mommer," said Max Rosenheim, proprietor of the Scotch Woolen Mills Emporium, High Grade Men's and Boys' Clothing, "I get me a letter to-day from Sol Ehrenberg in Cincinnati and he gives me a tip that the wool market is agoin' to tighten up, and I better hurry to get my fall and winter line, so I guess I take the train and go there before prices get any higher, which I am ashamed now to ask a decent profit on."

"Now, ain't that what you call a quincidence," said Rachel, "I also gets a letter from Rosy Goldstein in Cincinnati askin' if I can't make 'em a visit, and seen' Aby and Rebecca are in the country we can both go just as well as not."

"Now, Rachel, you know that travelin' tires you out and I think it much better if you go out to the country too, because I won't have any time to go round with you and—"

"Max Rosenheim, always you make business the excuse that I can't go with you, but this time I am

"Nonsense, Rachel. I am sure you will like it and mebbe if you are lucky you might win enough money to pay all your expenses."

"Gamblin' on the horses? Rosy, how can you say such a thing? Never would I make a bet. It ain't right."

"Well, I ain't sayin' whether it is right or wrong, but about twenty thousand good respectable people are doing it every day."

At Fourth and Vine they boarded the green car marked "Latonia," and crossed the bridge into Covington. Winding around the green hills the long procession of cars one by one deposited the passengers at the entrance to the track. A babel of voices greeted Rosy and Rachel as they walked up the graveled path. "Here y'are, Race Track Information, four winners in a row yesterday, that's the way we pick 'em. Get the Rail Bird, long shot in the fourth. The Old Reliable J. J. Sterling, the clocker 'hat picks 'em. Tod Sloan's card, only fifty cents. Who wants Isador MacKune to-day, Isadore MacKune, for a quarter?" "What is it them fellers are selling' Rosy?" inquired Rachel.

"Tips on the races. Don't pay any attenshun to them, Rachel. They guess on the winners like everybody else, only they try to sell their guesses. Nobody but suckers buy that dope," counselled the wise Rosy.

"Rosy, I feel ashamed to think I am here enjoyin' myself so much when poor Max is over in the city workin' so hard. Never do I want him to find it out because I know he don't approve of horse racin'—"

At this moment a familiar voice was heard in the crowd back of the last row of seats: "I tell you, Goldstein, I think the best way to beat this game is to do like you do in any other business. You buy information from fellers what know more about it than you do. Now yesterday I try to pick 'em myself and not a winner did I get. To-day I buy me one of them tips and right away I get the right horse."

"Sure, Max," said another well-known voice, "you buy a tip for two dollars on Right Over Might and the horse pays \$2.90. But where is the profit?"

A large lady rose majestically and called, "Max Rosenheim, ain't you ashamed of yourself? Sneakin' away to the races and me pitying you for working so hard. Come here."

Max, followed by the grinning Goldstein, crowded in where Rachel and Rosy were seated. "I tell you, Rachel, all morning I look over clothing samples till I get me a headache, and when someone proposed that we come over for a little relaxashun, why of course, I couldn't object, could I? Why, mommer, you know ordinary I don't care for nothin' like this. I—"

"Shut up, Max Rosenheim. I guess I teach you somethin'. I guess I give you drastic punishment. You open your pocket book." Obediently Rosenheim opened his bill book and Rachel deftly extracted a hundred dollar note. Without looking at the denomination she waved the green signal to a messenger, who hurried over.

"I want to make me a bet."

"All right, lady, what horse do you want?"

"Well, what horses have you got?"

"Look at the program, lady."

"Which one is it that can run the fastest?"

"Lady, believe me, if I knew that, I'd have Whitney's string in six months."

Rachel glanced at the entries. "Pastreau, Brookholt, East Indian, Be Frank, Best Pal, Drastic. There it is. I say I do somethin' drastic and here is a horse with the same name. I pick him. I bet this on Drastic."

"Straight, place or show?"

"Which?"

"Do you play the horse to win, place or show?"

"Oh, I play the horse to win, of course. For why should I play him to lose?"

The messenger wrote out a ticket, one hundred to win, giving Rachel the pink receipt.



goin' to have somethin' to say. I guess Rosy and me can find our way about Cincinnati without any help from you, so it is all settled—I go." "Oh, well, mommer, it ain't that I don't want you should go, understand. Always I like to have you along, but I was thinkin' about your comfort, and if you think you could stand the trip in this here hot weather, why, I get the tickets."

Arriving at the Walnut Hills home of the Goldsteins, Rosy insisted that Max and Rachel should cancel their hotel reservations at once. "Foolishness it is to pay them robbers such prices as they ask when we have plenty of spare room. And while Max is gettin' him bargains from the wholesalers, Rachel, you and I will take in all the speshul sales along Vine street."

The next day after luncheon Rosy said, "Now, Rachel, while Max is away quarrelin' with them clothing sharks this afternoon, you and I will go to Latonia."

"And what is Latonia? Is it mebbe a pitcher show or a department store?" "It is a race track."

"A race track. My, my, Rosy, I wouldn't dare. Max he don't never take any interest in such things and at my age it is wicked to go to such places."



"Now look what you do, Rachel, you bet a hundred dollars when King Gorin is sure to win the race."

"I did not. It was a ten-dollar bill, wasn't it?"

A look at her receipt showed that she had bet \$100.

"Oh, well, I don't care. I lose the money and teach you not to be so deceiving."

Eleven horses lined up at the barrier to race for the \$5,000 stake and silver cup in the Enquirer Handicap. A thousand voices yelled "they're off" as the barrier sprung, and the line of thoroughbreds leaped forward, Miss Jemima in the lead, followed by Best Pal, Be Frank, and the rest in a bunch. At the half-mile pole Miss Jemima dropped back and Midway took the lead with Brookholt following. Down the



stretch they came in a cloud of dust. Brookholt had the rail and looked like a sure winner when Drastic, coming up from the rear, forced him to swerve to the outside, leaving an opening. Leaning forward in his saddle, Jockey Pool laid on the whip and Drastic crossed the wire, winning by a length, Brookholt second.

"Drastic wins," cried the excited Rosy, but Rachel refused to be worked up.

"Do I get my money back?"

"Do you get your money back? Wait till you see the price posted."

In a few moments the men at the price board pick-up the white figures and placed them opposite the winners. No. 4,003, \$16.80, \$7.30, \$5.20.

"The horse paid \$16.80 to win," said Rosy. "My, but you are lucky."

"I see no luck in that. But I don't care, for I want to punish Max. See, Max, I bet me a hundred dollars and get back \$16.80, which is enough to teach you that it is wrong to deceive your wife and gamble. And now we go home. Racin' I do not like at all—"

"But, Rachel, you do not understand. You get \$16.80 for each two dollars. Here, gimme your pencil and we'll figure it up. That means fifty times \$16.80, which is—goodness, Rachel look. You get back eight hundred and forty dollars."

"Rosy, you can't mean it. They won't pay it. Eight hundred dollars they will never give me for just guessin' which horse would win. Or mebbe that there messenger forget to come back. I know somethin' will happen."

But nothing did happen for presently the messenger arrived and counted into Rachel's trembling hands eight hundred and forty dollars. "My, my, Rosy, how long have they been doin' this? Never before did I see a quick return from an investment. Max, I guess I forgive you this time and now I want to make me another bet."

Looking at her program, Rachel said, "What does it mean this field?"

"The field is where there are a lot of horses entered and there ain't room on the racing board, so they bunch some together under one number. If any one of them wins you win."

"Oh, I see," said Rachel, "it is sort of a bargain remnant sale. Well here in the field is Peri, Martha Gray and Lough Storm. Max, I guess I bet on the field where I have three chances to win. Here is ten dollars. You make the bet."

Max and Goldstein started downstairs to the betting ring. "Goldstein," said Max, "that horse Bettina is sure to win this race because a feller told



me so. Now why should I let Rachel throw away ten dollars on them dogs in the field?"

"Well," said Goldstein sagely, "in a horse race you never can tell. Suppose the field wins, what will you tell Rachel?"

"I tell her nuthin' but pay the bet. It is better that I should get the ten dollars than to throw it away."

As the horses turned in the stretch Max Rosenheim was yelling himself hoarse, calling for Bettina to win.

"What do you mean, Max? I have a bet on the field. Why should you want another horse to win?"

Max did not reply for at that moment a red streak dashed through the bunch of horses at the judge's stand and Lough Storm, a first-start filly, easily won the race.

"No. 11 wins," screamed Rachel, "and it was a field horse."

"You see," whispered Goldstein, "never can you tell about a horse race. I bet this costs you some money for the field didn't get much play."

"Never did I see such luck," said Max gloomily,

"and I bet that horse pays ten dollars which means it costs me fifty for Rachel."

Max came pretty near fainting when the prices were posted, Lough Storm paying 73.40. "You hurry down and get that money, Max. Rosy she tells me that it figures up to three hundred and sixty-seven dollars."

Max crept back of the Coca-Cola booth and counted out \$367 which he presently handed to Rachel, who generously gave him twenty-five back. "In this next race I think I play twenty dollars on Tom Saunders, because it is the same name as the butcher at home who allus gives me good weight."

Max holds the bet and Tom Saunders wins, paying \$8.80, costing him \$88 to make good with Rachel. The next race Rachel plays fifty dollars on Arrow Point and Max gives a sigh of relief as Lady Mountjoy crosses the line a full length ahead.

"I don't think she could pick 'em every time and that is fifty I save," he said gleefully to Goldstein. Mebbe now if she plays enough races I can get all my money back and some of—hey, what's he doing over there? It's a swindle I say. That's what it is. Such highway robbers."

What he was doing was enough. Lady Mountjoy was disqualified for foul and the race awarded to Arrow Point. Loss to Max Rosenheim \$450.00 which he gloomily paid to Rachel.

"Well, Max, there is just one more race to-day," said Rachel, "what are you going to play?"

"I figured on playin' this Frank W., but I've kinda lost confarence in myself. What are you going to play, Rachel?"

"No more am I going to plunge to-day, Max. I think this horse Queen Blonde has a pretty name, but I just play two dollars."

"All right, Rachel, then I play two hundred on the same horse, although I have a stable tip that Frank W will win, but it don't look like them experts is right to-day."

Alas for Rosenheim. For once the feed-box information was right and Frank W. romped in at a price of \$13, 10 to two, with Queen Blonde out of the money.

"Can you beat that? said Max gloomily as they started for the city. "Just a little two dollar bet that I place as Rachel instructed loses, and them I hold wins at long prices."

"You never can tell about a horse race," said Goldstein for the third time.

"Horse racin' ain't what I thought it was at all," confided Rachel as they entered the taxi she ordered Max to hail. "I believe I come again." "Just like a woman," growled Max. "Gamblin' is wrong—if you lese."

## Operating a Garage at Nights *By F. H. SWEET*

**Y**OUR idea as to operating a garage day and night is sound fundamentally, for you have your equipment idle over half of the time when you are operating only during the day—and you have to pay interest on your investment for the full time. As to whether or not there would be enough work to keep you busy both day and night depends entirely upon your local conditions and you, yourself, will have to be the judge of that. Naturally, business houses having trucks and delivery cars want to have them overhauled and repaired in the shortest time possible. If they can bring them in at the end of the day's work and have the work done on them during the night so that the car will be ready for service in the morning, they surely would be willing to pay extra for that kind of service.

Undoubtedly you have already made some investigations as to the amount of work which you would be likely to secure to keep your night force at work. A careful canvass of your prospective customers would serve to indicate what the possibilities in that line would be. You might find it advisable to operate only during part of the night, say up to midnight, for a time until you have sufficient work to keep both of the men busy all night. The difficulty with a night force is to get reliable men, who will work all of the time and not do any considerable amount of loafing. As you are around during the daytime, you, of course, can check up your day men and see that they do the full amount of work. By laying out the work that should be done by your night force and

*A correspondent writes: "I have a small garage, 50 by 75, and have been doing repair work only. The garage has been closed during the evening. My idea is that if a man can make money in nine hours, he can make money on a 24-hour basis. This town is about 18,000 population. Why shouldn't there be work all night on trucks and delivery cars that are in use all day and off nights? I figure that although a person would have to pay more for a mechanic to work nights, there would be no rent to pay and the extra lights wouldn't amount to a very big item. I should like your advice on this. I expect to employ two men and myself in the daytime, and two men at night, and intend to have my wife help me with the book work whenever she can. I have a small tool room, or parts room, and I am going to get a time clock of some kind. I don't know just what kind will be the best. I also like to have work cards punched because a man working can't, as a usual thing, find a pencil handy. I intend to do business on a cash basis. But there are always cases, for instance, when a business man has someone else call for his car, when there is bound to be some charging done. I like the idea of 'no verbal word goes'—everything to be written down and hung on the car. If a job came to more than was expected and the party would not have the cash for a month, I would like to see some form of a note that would bind the party so that one could take his car at any time after the time was up, without going through all the red tape of getting a lien on the car, or if the car had been sold, hold some other property, providing it was not mortgaged. I am figuring on getting work reports and billheads printed. What is a good book to use for a ledger—the loose-leaf or the other, and how would you start out? I also want a book for shop expenses, a book of parts bought, a cash book, and a day book."*

knowing the time it should take, you will know fairly well whether or not they are really working.

**A**S you are located in a comparatively small place, you should have no difficulty in ascertaining any prospective customer's financial standing and reputation as regards paying his bills. The grocer and butcher are probably as well posted in regard to a man's habits in paying his bills as anyone you could find. If you have any doubts about a customer's ability to pay, it would be well to look him up before you put any great amount of work on his car.

It would probably be rather difficult to work out any form of agreement which would bind the party to give up his car at any time without going through the usual legal forms. The best prevention is to insist upon cash payment, especially in those cases where you are at all suspicious of the ability of the party to pay.

We would recommend that you make a careful investigation of time clocks before you purchase. For the small force you have it is not necessary to obtain an expensive equipment in that you can probably keep track of the time put on the various jobs fairly well without a time clock, at least until you can get your bearings.

For your bookkeeping records, etc., I suggest this outfit: Two hundred cash journal leaves; 100 general ledger leaves; 100 customers' ledger leaves; 100 vendors' ledger leaves; 100 expense ledger leaves; 2 top-lock binders and 4 division sheets.



# Selling Autos, Accessories and Implements

Service, Satisfaction, Success, is the Slogan of Bachand & Dionne, of Coaticook, P.Q., Who Find the Farmer's Wife and Children are Worth Cultivating

"MY definition of service is to give satisfaction and this is the kind of service our customers expect of us. To insure satisfaction we sell only A1 goods and we get behind the lines we sell," says J. D. Dionne, manager of the firm of Bachand and Dionne, Coaticook, P.Q.

Coaticook, so called by the Indians because of the crooked river running through it, is the pivot and centre of a very prosperous farming country, with big livestock men and farmers all around. Six years ago the firm of Bachand & Dionne started as subagents for LeBaron Auto Sales Company, selling the McLaughlin car.

The motor business was only a side line as Mr. Bachand had a wholesale grocery concern, and Mr. Dionne was then working as a clerk in the grocery. Mr. Bachand is one of the leading men in Coaticook, owning a lot of property and controlling a very prosperous business. He never took an active part however in the automobile agency but became more and more interested financially, till, at the present time he represents the financial man behind the company, and Mr. Dionne is the man who pushes the business—a very much alive and active manager.

## Two Cars The First Year

During the first year two cars were sold, and after two years the firm broke away from the LeBaron Company and became direct agents for the McLaughlin Company. The automobile business developed as the years went by and Mr. Dionne dropped out of the wholesale grocery, and, taking Mr. Bachand's money as capital, devoted his time to the automobile agency. In 1918 the Chevrolet agency was taken over, and in June, 1919, the Canadian Fairbanks-Morse lines, including tractor, stationary engines, lighting plants, water systems, were taken on.

The firm now has the upper hand and has the agencies for such centres as Magog twenty miles away. They are now under contract to sell a number of cars each month, with the firms they represent, and the lines carried are accessories, tires, bicycles, and saw rigs, but automobiles and implements are the main lines.

## A New Building

On a dominant site on the main street of Coaticook, a new \$28,000 solid brick garage has recently been built, 100 feet by 55 feet, and plans are under way for the extension of this building another 50 feet. It is finished with the most modern equipment such as overhead trolleys for raising cars above ground when working beneath. There are two heated rooms for re-varnishing cars, where no dust can reach them. The cellar is being devoted to the storing of automobiles and a large

By V. FRAY

business is done in this way at night. In connection with the garage there is a storage battery service and also a vulcanizing plant. A Hart accumulator is used in the battery department.

An isolated corrugated building, 100 feet by 50 feet has been set aside for the storing of cars, and

day service is given. One deal in Magog was closed recently at 2.15 a.m. showing that with this very much alive and aggressive firm time is no hindrance. All the selling work is done by Mr. Dionne and his salesman, Mr. Sorel.

## Selling the Farmer

They go out at least four days a week, usually doing the selling work in the afternoon and night. Their policy is to go after the farmer on the farms and sell them whatever they seem to need. Often two or three lines are sold to the same farmer at the same time. The best work is done in the evening when the farmer has finished his own work and has time to talk and to listen. Sometimes eighty miles are covered in this way. In selling to the farmer not only is the implement or car demonstrated but the farmer is taught to drive.

Notes are accepted from reliable sources, generally for about fifteen months. Nothing direct has been done in respect to exhibiting at local fairs, although the firm has always been represented, and local newspaper advertising is carried all the time.

## Lighting Plants and Farm Trucks

Lighting plants have taken a very successful grip of the country around. Last fall, the first time the firm sold them, fifteen were sold, but a big campaign is being carried on this fall and

larger sales are expected from a territory of about thirty miles around Coaticook.

So far the selling of trucks has been a side line, but this year a special effort is being made to sell the farmer three-quarter ton trucks. The truck versus the horse is the slogan and with the cost of grain sky high and the saving in time and labour, the horse is now the luxury and the truck the economy. A special campaign for the sale of trucks is being undertaken this fall.

This summer a drive was made in connection with the sale of second-hand cars and during the month of August sixty second-hand cars were sold. This is considered exceptionally good because the sale of second-hand cars is becoming harder as the years go by. A man is not anxious to buy a used car even at a

low figure, he goes after the new machine. No difficulty, not even the increased cost of freight, has affected the sale of implements or cars. During the war the farmer bought warily, but since the end of the war the farmer is more than willing to buy, in fact, he comes after the car himself.

On asking Mr. Dionne if he made any point of selling the farmer's wife, he said: "She is the person we go after to point out the saving caused by the use of lighting plants. 'In fact,' said Mr. Dionne, 'in selling to the farmer we sell to the whole family.'"



Bachand & Dionne's garage, Coaticook, Que., is in pleasant surroundings and is a busy car centre.

the insurance for a car in such a fire-proof building is very low. During the summer this building is used for overflow purposes and for storing cars. The sales offices and showroom are in a separate building.

Early in the spring the farm motor truck goes "over the top" and this is followed closely by the big push for the sale of automobiles in the summer. The tractor is also boosted in the early spring when the need for it is felt. Water systems are sold both spring and fall, and during the long winter months, when the nights are dark, and when it will appear most attractive to the farmer and his family, lighting plants are sold.

With sixteen mechanics and outside employees, twenty-two people are employed in all. A night and



The workroom of Bachand & Dionne is a spacious place and fully equipped for servicing autos, trucks, and tractors.





# Primrose

Primrose Separator popularity reaches into every section where there are cows and milk and cream. Each sale made by the agent—each Primrose established in the hands of a new owner—makes future business the more secure. Primrose quality and efficiency is nowhere denied.

Nevertheless it is true of Primrose agents that Providence helps him who helps himself. Help yourself to scores of sales with the aid of our advertising campaign. Supply the branch house with a list of Primrose prospects. To all of them we will mail a series of catalogs, folders, etc., unusually attractive, printed in colors, full of strong selling features. In addition, we will furnish you with a display for your show window, newspaper advertisements, reading notices for your local newspaper, demonstration tags, etc.

This comprehensive campaign goes with every Primrose contract. Primroses sell fast and may be made to sell faster. See the blockman.

## INTERNATIONAL HARVESTER COMPANY

OF CANADA LTD.

HAMILTON CANADA

WESTERN BRANCHES — BRANDON, WINNIPEG, MAN., CALGARY, EDMONTON, LETHBRIDGE, ALTA., ESTEVAN, N. BATTLEFORD, REGINA, SASKATOON, YORKTON, SASK.

EASTERN BRANCHES — HAMILTON, LONDON, OTTAWA, ONT., MONTREAL, QUEBEC, QUE., ST. JOHN, N. B.

## Help Your Customers Build Up Their Land with McCormick or Deering Manure Spreaders

There is every good reason why the farmers of your territory should build better crops by building up their soil with manure—valuable plant food that will give life and strength to healthy seed. And there is no better or quicker way to spread manure than with a **McCormick** or **Deering** manure spreader.

We are making them realize that much depends upon even, uniform spreading. Spreaders bearing the names **McCormick** and **Deering** are noted for their thorough pulverization of the manure and for even spreading. This is backed by practical facts. It is due to the effective operation of the positive apron feed, the chisel-pointed steel teeth of the fast-working, broad-diameter steel beater, and the spiral wide-spreading attachment, which gives the manure a second beating, as it distributes it finely and evenly well beyond the wheels on both sides.

Our advertisements refer readers to the nearby International local agents. We tell them that you will be glad to tell them more about **McCormick** and **Deering** spreaders. Let us co-operate with you to the fullest extent in the sale of more manure spreaders.



## INTERNATIONAL HARVESTER COMPANY

OF CANADA LTD.

HAMILTON CANADA

WESTERN BRANCHES — BRANDON, WINNIPEG, MAN., CALGARY, EDMONTON, LETHBRIDGE, ALTA., ESTEVAN, N. BATTLEFORD, REGINA, SASKATOON, YORKTON, SASK.

EASTERN BRANCHES — HAMILTON, LONDON, OTTAWA, ONT., MONTREAL, QUEBEC, QUE., ST. JOHN, N. B.



# An Improved Haycocking Machine

By J. H. RODGERS

**T**HE machine here illustrated is an improved design of haycocker developed some years ago by Avila Savignac, of Joliette, Quebec, and patented last year. Just recently this machine was given a practical test before a representative body of agriculture experts from the Dominion and Provincial Departments of Agriculture and also many members of the Province of Quebec Farmers' Association.

As is the case in all mechanically operated devices the principal object of this haycocking machine is the saving of hand labor, a very important factor at the present time when great difficulty is frequently experienced in getting sufficient help on the farm for the efficient harvesting of the various crops of hay and grain. The tedding and cocking of 400 acres of hay on the

vator at the point 1. The rake prongs, when picking up the hay, operate through a lightly constructed cage Q, which aids in supporting the prongs and at the same time prevents the hay from following up on the same.

When the machine is moving the hay is pushed forward by the action of the revolving prongs, the advance of the rake being relatively greater than the machine travel owing to the ratio of the gearing. As the hay is pushed forward it is placed on the primary elevator at the point 1, and thence is carried to the point 2 where it is forced between the two elevators G and H, carried upwards and discharged into the hopper at the top of the machine. The rear operator of the machine, sitting in the seat R, and by means of an ordinary hay fork, takes the hay from

tion of the lattice drum, thus permitting the cock of hay to slide to the ground. To close the rear half of the drum and raise the lower rack, the treadle is again pressed down when the dog is again engaged until the crank assumes its initial position, at which point the dog is released from the ratchet wheel by contact with a pin on the cam of the dog. It might be stated that the system of levers are duplicated on the opposite side of the machine so that all moving parts work in unison.

Several of these machines now in operation are giving every satisfaction and farmers in this district, as well as officials of the Department of Agriculture have made the statement that this class of farm equipment is of inestimable value to the farmers as a labor saving device.

## LAUSON WINS AT LINCOLN

**A** CABLEGRAM received recently from England by the John Lauson Mfg. Company, New Holstein, Wis., announces the Lauson tractor was awarded the first prize at the Lincoln trials; first prize consisting of gold medal and twenty pounds.

A few of the conditions under which the tractors competed are summed up as follows:—

1. Hauling direct in work or on the road, a plough, cultivator, harvester, or other agricultural implement.

2. Driving barn machinery.

3. Competitors had to plough a given area of land commencing with the size of furrow specified for each class, during which the fuel and water consumption was recorded, and subsequently varying the depth and width at the discretion of the judges.

4. Special attention was paid, in the ploughing and cultivating trials, to the compression of the land by the machine, the space and time occupied in turning, the uniformity of the furrow ends and evenness of the furrow.

5. The following are some of the points to which special attention was directed:—

(a) Weight of machine.

(b) Weight per inch width of wheel and diameter of wheel.

(c) Mechanical design and construction.

(d) Adaptability to various kinds of work, such as harvesting and the like.

(e) Time taken to prepare for work.

(f) Ease and safety of handling.

(g) Ease of turning and space required for same.

(h) Efficiency of winding gear.

(i) Facility of attachment.

(j) Wheel devices.

(k) Attendance necessary.

(l) Consumption of fuel, water and other supplies per unit of work done.

(m) Price.

A large number of tractors of foreign makes were entered in the trials.

## MARKETS FOR AGRICULTURAL MACHINERY IN CHILE AND PERU

**B**OTH Chile and Peru have growing agricultural industries and afford good potential markets for the sale of American agricultural machinery, reports the Foreign Trade Bureau of the Guaranty Trust Company, of New York.

The arid coastal plains extending the length of Peru are the chief agricultural region in which the important crops of sugar, cotton and rice are produced.

The central valley of Chile is the chief crop-yielding section, and is noted for wheat and other grains.

Agriculture in Chile and Peru has long been a most important activity, but the methods employed before the war were primitive. In response to the war demand for increased production both for domestic needs and for exportation, and, in view of the labor shortage in this industry caused by better wages being paid to miners than to farm hands, scientific methods were necessarily resorted to. Modern machinery—mostly from the United States—was impressed into service more rapidly than would otherwise have been the case.

Irrigation has been a necessary factor in increasing the production in both these countries, and both Governments are promoting irrigation improvements. By the extension of irrigation and the employment of modern machinery, the production areas will be extended and enlarged crops will be made possible.

Agricultural machines must be well constructed, and adapted to the needs of these countries. Efficient demonstration must precede sales to the Chilean and Peruvian farmer. The steam engine tractor has been found too heavy for satisfaction, but the gasoline tractors have been increasing in favor.

## APPOINTED TO HYATT STAFF

**T**HE Tractor Bearings Division of the Hyatt Roller Bearing Company, Chicago, Illinois, announces the acquisition of Reuben Kuempel to its staff of engineers.

Mr. Kuempel is well known in the trade, having been identified with the automotive industry since 1913. During the war he served on the Bureau of Engineering, Aircraft Power Plant Section. Since that time he has filled the position of Tractor Engineer for the General Ordnance Company, New York City.



This picture shows Haycocker Machine in operation.

farm of Pierre Lavalee, at St. Norbert, Quebec, was accomplished by two of these machines, with a boy and man and two horses to each machine. The boy sits on the front seat to drive the team while the man at the rear attends to the packing of the hay into the drum at the back of the machine, from which it is deposited on the ground in cocks of about 300 pounds each. The complete machine weighs approximately 1,400 pounds.

The operation of the mechanism is derived by the movement of the machine itself, the rear wheel A on one side carrying a large sprocket B that drives the various parts by means of the endless chain C passing over the smaller sprockets D, E and F. The shafts that carry the sprockets E and F are the full width of the machine (14 feet) and are fitted with other sprockets for controlling the movement of the endless elevators G and H. These are made of light wooden slats uniformly spaced and bound together by the link chain for operating purposes. The elevators are supported on the lower end by the sprockets I and J, three of which are located on each shaft, one at either end and one in the centre. Idlers are suitably located to take care of the sag of the moving elevators. An auxiliary drive L is provided for operating the smaller elevator M, this unit being adjustable to position by means of the swinging arms N, one being placed on either side of the machine.

For raking the hay from the ground differential gearing is provided, this being fitted in a special three-winged casting at one side of the main rake shaft. The opposite end of this shaft carries a three-winged piece O for supporting that end of the auxiliary rake shafts upon which the rake prongs P are secured. By this arrangement the prongs are always held in a vertical position and permits the free discharge of the hay as it is lifted from the ground and placed on the primary ele-

the hopper 3 and packs it into the large lattice drum 4. When this drum is full the operator presses down the foot treadle S, which, by a system of levers, engages the dog T with the ratchet wheel U, causing the crank on the outer end to make a half turn, and by means of the connecting link V, the arm W is lowered. The arms X and Y, secured to the same shaft, are turned through an angle of about 65 degrees. The arm X is connected to the lower rack by means of a chain so that the rack is supported in a horizontal position when the drum is being filled with hay. When arm X is lowered it permits the rack Z to fall to the ground in an inclined position. At the same time the arm Y moves backwards, and through the link 5, pulls open the rear quarter sec-

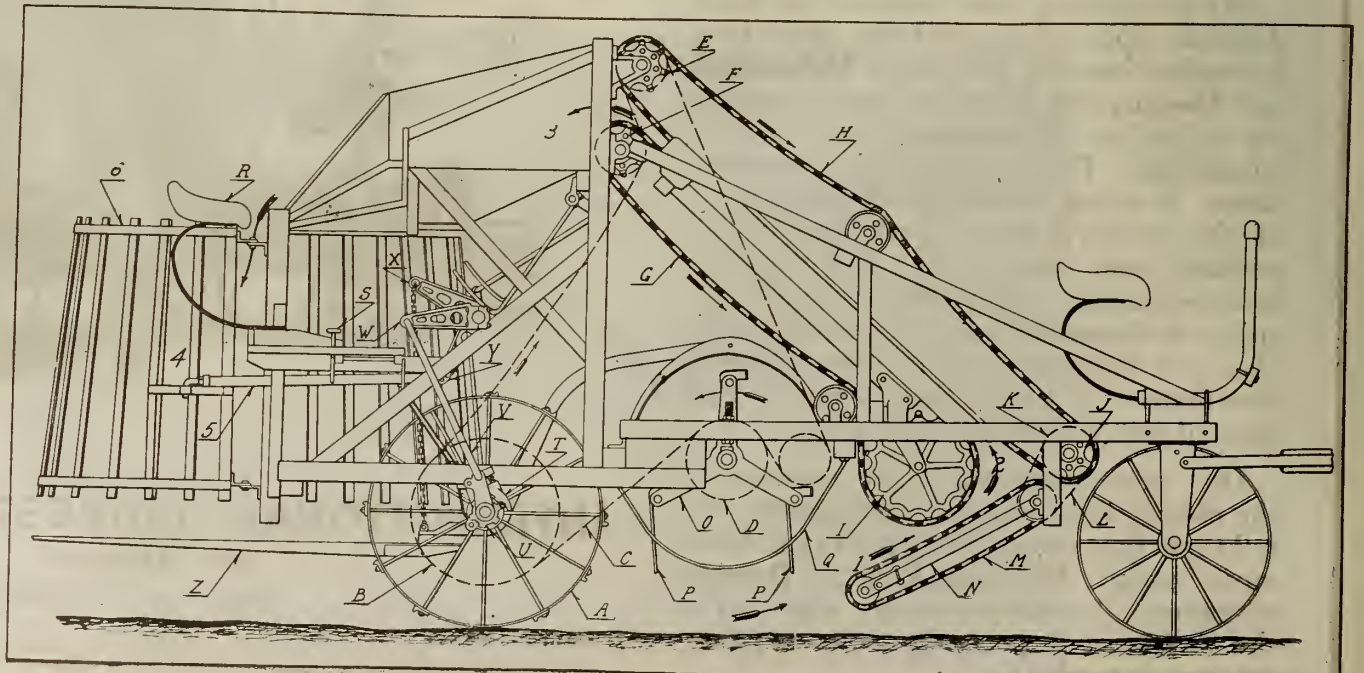

Line drawing showing working parts and their function.



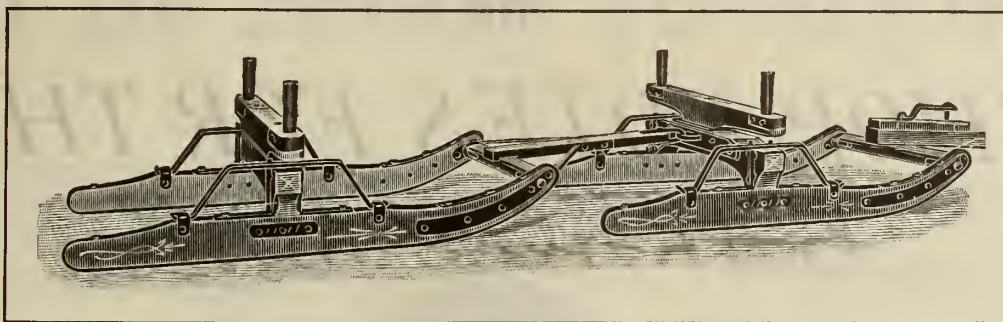

# Adams Sleights and Brantford Cutters

Built in Canada for Canadian conditions—these Sleights and Cutters have a splendid reputation throughout the country. You're sure to have pleased customers when you supply them with Adams Sleights and Brantford Cutters.

## Sleights with Rugged Strength

Heavy Oak Runners stand up under heaviest loads and hardest work. Steel or Cast Shoes are proof against holes, ruts and jolts. Benches and Bolsters are ready for years of real service. Couplings, Reaches and Chains are good for any load. There's Adams Quality in every feature—Quality that is appreciated by your customers.

## Cutters for Comfort and Style

We have been building Brantford Cutters for over 30 years and know intimately just what the trade demands. We also know how to build cutters that satisfy. Our designs are modern and thoroughly Canadian. Their finish and trimmings are the best for the purpose that money can buy. Better than all they have the Sturdy, Rugged Quality of materials that have made Brantford Cutters famous.

*Catalogues giving complete specifications of our lines of Sleights and Cutters will be sent upon request. There is good business in sight. Go after it early.*

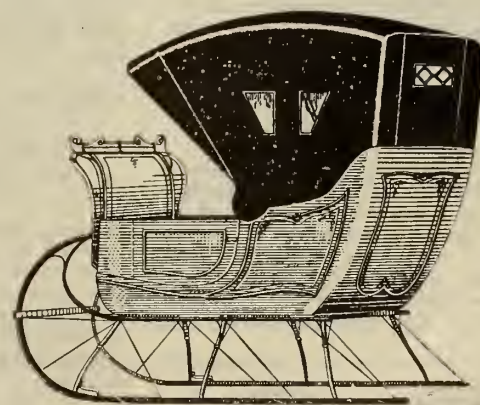

Send for our dealer proposition. It's interesting. To the dealer who realizes the value of a complete line of Implements, it is a Money-maker. Cockshutt-Frost & Wood Implements, quality built, backed by steady, consistent advertising, have built up success for hundreds of dealers.

**Cockshutt Plow Co.**  
LIMITED

BRANTFORD, ONTARIO

*Sold in Eastern Ontario,  
Quebec and Maritime  
Provinces by*

**The Frost & Wood Co.**  
LIMITED

Montreal

SMITHS FALLS, ONT.

St. John





# SHOP NOTES FOR THE GARAGE MAN



## CLOCK TELLS WHEN TIRES ARE CURED

EVERY tire repairman when curing tires has been faced with the difficulty of keeping a proper check on the different molds when several tires are in process of being cured. Some repairmen as soon as a tire is set up on the mold mark down the time when the process was started and when the cure should be completed. This necessitates the repairman watching the time closely. Other dealers have devised other schemes but the best device, to our mind, and one that makes for absolute certainty, is one that uses an ordinary clock and dry cell batteries. It works automatically and can be made by any repairman.

It consists of an ordinary kitchen clock with the dial insulated from the works and with holes bored or punched at each minute mark. There are a number of plugs or pins bearing numbers corresponding to numbers on the molds. The clock is operated from dry cells. One wire is connected from the batteries to the works; one from the dial to a small bell fastened on the side of the clock, and another wire direct from the batteries to the bell.

When a tire is put on a mold to be cured, the plug with the number corresponding to the number on the mold is taken and put in at a hole separated from the starting point by the number of minutes the tire is allowed to be cured. When the minute hand touches the plug at, say 45 minutes, the circuit is completed between works and bell, the bell rings and the tire is ready to come off the mold.

Several tires can be on the molds at once and each will ring off at its own time. With this system the repairman is free to go about some other work without worrying about the curing.

## TIRE-REPAIR STAND

THE accompanying illustration shows a simple tire repair stand for the handling of tires and tubes which will be of interest to the tire repairer. It is constructed of wood and is easily made. It consists of a framed support and two semi-circular blocks; one of the blocks has a flat face for use in re-

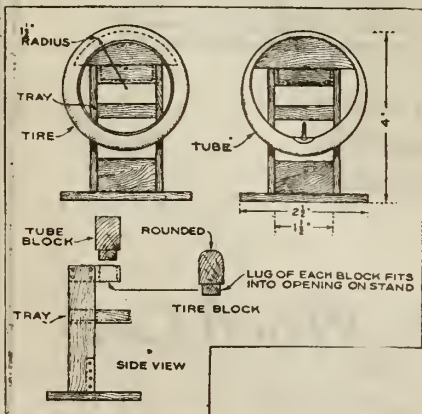

pairing tubes and the face of the other is rounded to conform to the inside of a cover placed over it for repair. A lug at the bottom of each block fits

into an opening provided in the top of the stand so that they are readily interchangeable.

## TESTING REPAIRED RADIATOR

AFTER repairing an auto or tractor radiator a dependable test can be made by using part of a discarded inner tube with the valve stem attached. Cut a circular gasket from another part of the tube, place it under the radiator cap to make an air-tight joint, and plug the overflow pipe securely with a small bottle cork. With the use of hose clips attach the tube, the inlet

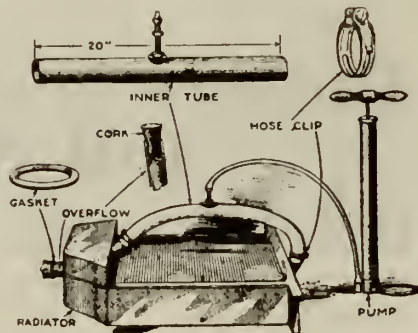

and outlet nozzles, lay the radiator in a large tub of water so that it is completely covered and inflate the tube sufficiently to cause a slight pressure in the radiator but not enough to cause injury. If there are any leaks they can be located by rising bubbles as the air has no other means of escaping if the other exits have been made airtight. Mark the leaks with chalk or with small pieces of wire twisted around them, and after soldering, replace the radiator in the tub for another test. A few repetitions of the process will detect all the leaks no matter how small.

## RESTORING DRY CONE CLUTCH

A GRABBING action of the cone clutch is occasioned either by the leather facing becoming very dry through use or by wear, causing the rivet heads to protrude above the leather face and come in contact with the metal of the fly-wheel. A dry clutch can be restored by sponging off the face of leather with kerosene and applying a dressing of either neats-foot oil or castor oil till the leather again becomes soft and pliable. If the leather facing is worn down to such a point that the heads of the rivets come in contact with the metal cone of the fly-wheel, the clutch will stick, and to restore the clutch it will be necessary to drive down the rivet heads into the leather so as to clear the cone. Leather facing that has become rough or uneven through wear can be restored by rubbing off the high spots with emery cloth, broken glass, a coarse file, or sand paper, making the surface smooth.

## TIRE INFLATION TABLE

A LARGE number of motorists and garage men have the impression that tires should be run under-inflated during warm weather and fully inflated during the colder winter months. The B. F. Goodrich Rubber

Co. recently carried out a series of tests to determine the wisdom or fallacy of this practice. A 34x4 inch tire, for which makers prescribe a 70-pound pressure, was used for the test. Air at various temperatures was pumped into the tires and they were then run at excessive speeds under severe road conditions. The changes in pressure were found to be negligible. Goodrich recommends an even pressure the year round with adherence to the pressure designated for the various sizes of tires. Frequent observations conducted by experts of the company have demonstrated that the vast majority of motorists keep their tires under-inflated. Even if hot weather makes a slight difference in pressure it would be policy to risk it rather than take the chance of having the tire under-inflated. Of the two the latter is far the worse and more universal.

In order that the correct amount of air in tires may be readily ascertained, a standard table for all makes of tires is shown as follows:—

Rim Sizes	Inflation Pounds	Rim Sizes	Inflation Pounds
28 x 3	60	33 x 4 1/2	70
30 x 3	60	34 x 4 1/2	70
29 x 3 1/2	60	35 x 4 1/2	70
30 x 3 1/2	60	36 x 4 1/2	70
31 x 3 1/2	60	37 x 4 1/2	70
32 x 3 1/2	60	38 x 4 1/2	70
33 x 3 1/2	60	40 x 4 1/2	70
34 x 3 1/2	60	42 x 4 1/2	70
36 x 3 1/2	60	33 x 5	80
32 x 3	70	34 x 5	80
34 x 3	70	35 x 5	80
30 x 4	70	36 x 5	80
31 x 4	70	37 x 5	80
32 x 4	70	39 x 5	80
33 x 4	70	41 x 5	80
34 x 4	70	43 x 5	80
35 x 4	70	36 x 5 1/2	80
36 x 4	70	37 x 5 1/2	80
37 x 4	70	38 x 5 1/2	80
40 x 4	70	39 x 6	85
42 x 4 1/2	70		

## REMOVING OLD PAINT AND VARNISH

THE most practical and economical method of removing the old paint and varnish from the body surface of the automobile, says the Vehicle Monthly, appears to be quite an open question with a great many people. The burning-torch cannot be used upon the metal surface as upon the wood, for the reason that the finish upon the metal will require such an amount of heat to start it that almost invariably the panels will buckle and warp; moreover, it would take too long to heat the paint and varnish to a condition to permit removal with the scraping knife.

Burning the paint from these metal surfaces being therefore out of consideration, the question arises what other available method or methods are to be had. If the sheet metal is sufficiently strong enough, and a sand-blast machine is at hand, this will prove the most effective way and the cheapest, of removing the finish.

The sand-blast machine will need to be operated at from 70 to 90 pounds' pressure of air, and the hose nozzle should be 3-8 inch. The sand used should be, preferably, run through a 16 by 16 mesh sieve. A light silica sand with a sharp cutting edge will be found best for the work.

To illustrate the efficiency of the sand blast as a means of removing old paint and varnish from the surface of

metal, it may be stated that the old paint has been removed from a 7,000-gallon engine tender in from two and one-half to four hours; possibly the average would be four hours.

However, in the absence of the sand blast the old finish, even when oven-baked and apparently as hard as the steel itself, can be removed with any one of the numerous paint and varnish removers now on the market.

One of the secrets of success in handling these removers is to first get the surface well moistened with the material. To accomplish this, pour the remover into an open container—a galvanized pail will serve the purpose capially—and apply to the surface with a 4-inch flat bristle brush. A brush partly worn in painting will suffice, although a brush with a good working stock and with a reasonable capacity for carrying the remover is always to be chosen; in fact, no other kind should be used, even if it becomes necessary to take for the work a new brush from stock.

Carefully apply the remover solidly all over the surface. Then, starting again at the point of applying the first brushful of material, proceed to brush on a second coat. The mistake is often made of brushing the remover too much; quite the reverse should prevail. That is, brush the material as little as possible, consistent with getting it evenly distributed over the surface.

Permit ample time for chemical action, and then, with a broad two or three-inch scraping knife, or a specially manufactured knife of a wider pattern than the available scraping-knife, proceed to knife off the material. Perhaps after this lot of paint and varnish has been removed, a third application of the remover will suffice to take off the balance of the finish. The workman will have to judge as to the number of applications by the thickness of the finish, its character, hardness of film, etc.

The baked-on finish will, of course, require more remover and a longer time for chemical action and more work to clean the surface. Paint and varnish remover cannot be hurried without such hurry proving more or less a disadvantage and detrimental to the quality of the work and to the economical interests of it. In the excess brushing of the remover on the surface no small quantity of the volatile solvents are lost.

As the workman proceeds with the use of the remover he will learn many such details of value which cannot be explained in this article. For example, he will learn how to save material, time, and possibly temper. And he will learn how to improve upon the quality of the work.

After cleaning off the finish, the next step will consist in washing the surface as a means of safeguarding the coats of paint to follow. Turpentine is a most efficient medium for this work, but at present quotations a cheaper material would suggest itself. Denatured alcohol, vinegar or a good turpentine substitute should suffice as a washing agent. Brush the material on generously, and wipe dry with soft cloths, but always make very certain that the surface is perfectly free of remover.



# "She'll be ready to-night"

There's a welcome announcement to every motorist who has experienced the annoying delays consequent to sending engine cylinders to the factory for reboring.

Your customers, whether owners of automobile, truck, tractor or gasoline engine, will be "tickled to death" with the service you give if you are using a

"I don't have to send the cylinders to the factory now"

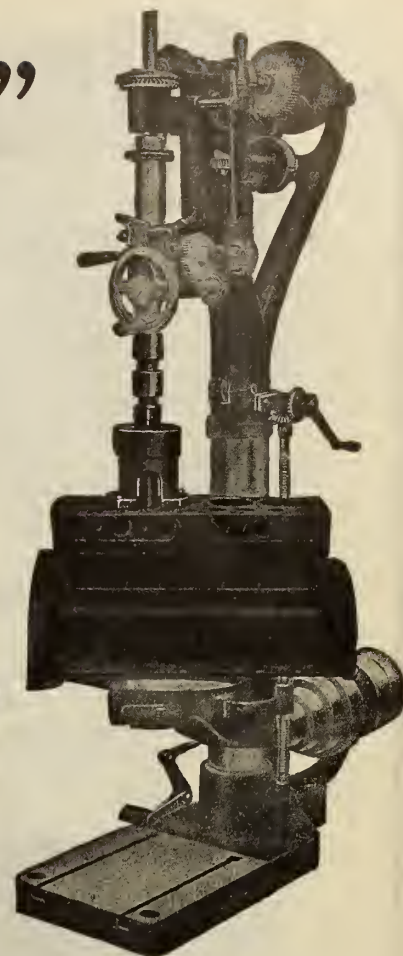

Operating with power-driven drill press

## Universal Cylinder Reboring Tool

This tool is used and recommended by these and other manufacturers — Ford, Dodge, Studebaker, Buick, Paige-Detroit, Chalmers.

Does as good a job as can be done anywhere. Eliminates delay, shipping difficulties, freight or express charges and exasperation. Adds to your profit and pleases your customers.

Can be operated by hand or in conjunction with a power-driven drill press.

*Clip the coupon and mail it to-day. We will gladly send fullest details.*

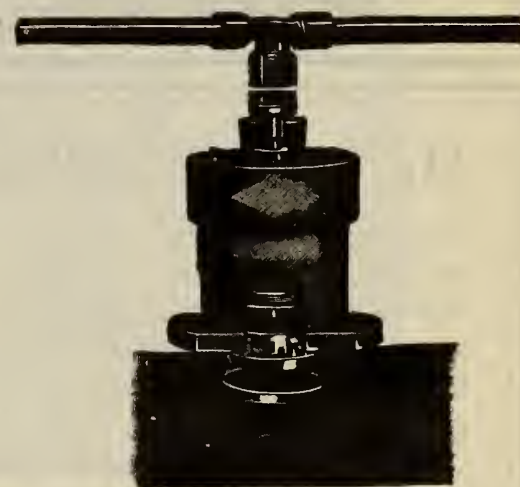

Operating on a detachable head motor---by hand



Tool complete ready for shipment

**Windsor Machine & Tool Works**  
312-318 Pitt Street, Windsor, Ontario

I, (or we) are interested in the UNIVERSAL CYLINDER REBORING TOOL, and would like to get more information on this equipment. You claim it will materially increase profits of this business; if so, I, (or we) are anxious to know about it.

Send any literature pertaining to same to

Name..... City.....

Street..... Prov.....

We repair the following cars.....

Name of my jobber.....



# Simplicity

ONE reason why Simplicity Engines last so long and give such satisfactory service is because they easily develop their rated horsepower.

The surplus power, over and above the normal rating, built into every Simplicity Engine, takes care of the strain when the engine is pulling to its full capacity. Surplus power means longer life, less wear and tear and vibration. Simplicity Engines are famous for long life and dependable power.

Sizes—Gasoline, 1½ to 16 H.P.; kerosene, 3 to 16 H.P.; stationary, skidded or portable.

Send for Price List and Catalog.

## The Turner Manufacturing Co.

441 Lake Street

Port Washington, Wis., U.S.A.

Export Department: 44 Whitehall Street, New York City

Distributors:

The Turner Tractor Sales Co., Winnipeg, Man.  
Power Farm Machinery Co., Edmonton, Alta.

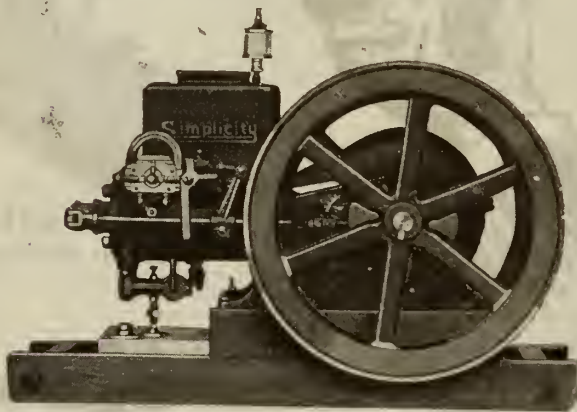

## He isn't a miller

The average dairy or stock farmer knows the beneficial effects of ground grain on his stock even if he doesn't know very much about milling or grinding. He knows what he wants and he expects his feed grinder to "know" how to produce it.

The best way to satisfy him, and the most profitable way, too, is to sell him a "Vessot" Feed Grinder. There are nine different sizes—you can suit anyone—and the "Vessot" is the simplest to adjust and operate. No technical knowledge is necessary.

"Vessot" Grinding Plates wear longer and cut better. Known by the "S.V." trade mark.



Write nearest branch of International Harvester Company for agency proposition.

INVENTORS AND MANUFACTURERS

## S. Vessot & Co., Joliette, Quebec

Sold exclusively in Canada by

International Harvester Co. of Canada, Limited.

Branches: Calgary, Edmonton, Lethbridge, North Battleford, Regina, Saskatoon, Yorkton, Brandon, Winnipeg, London, Hamilton, Ottawa, Montreal, Quebec, St. John.

## NEWS — OF THE TRADE FOR THE TRADE

### ONTARIO

**HAMILTON.**—W. L. Aspen has sold out his automobile business here.

**DUNDAS.**—E. Dyment and Son, implement dealers, are going out of business.

**NAPANEE.**—Fire caused considerable damage to the Lennox Garage, recently.

**TORONTO.**—Omnium Oil, Limited, with \$250,000 capital, was incorporated recently.

**ROCKWOOD.**—Guarantee Batteries Limited, have been incorporated with capital at \$300,000.

**GODERICH.**—The People's Garage is a new business opened here. J. G. McGee is the proprietor.

**TORONTO.**—The incorporation of Fulton Motors, Limited, is announced with authorized capital at \$100,000.

**WELLAND.**—The Joseph Stokes Rubber Company, Limited, was incorporated recently with a capital of \$100,000.

**CHATHAM.**—The Imperial Oil Company's pump house was destroyed by fire recently. The damage is estimated at \$1,000.

**KINGSVILLE.**—Fox Bros. and McKay have been awarded the County of Essex for the sale and distribution of Beaver motor trucks.

**HAMILTON.**—S. E. Ryder, Canadian manager of the Motor-Meter Company, of Canada, Limited, has opened the company's plant here.

**AGINCOURT.**—A. Kennedy, farmer, won first prize in the farmers' tractor plowing class at the Hamilton plowing match and tractor demonstration.

**KINGSTON.**—Fred. M. Clow, implement dealer, has been elected a director of the recently formed Ontario Implement Dealers' Association.

**KITCHENER.**—The annual plowing match of the Waterloo Township Plowing Association was held recently on the farm of Titus Kolb, near Kitchener.

**GUELPH.**—Prof. W. H. Day, of the Shinn Mfg. Co., officiated as Field Manager at the tractor demonstration at Macdonald College Farm, Oct. 12-14.

**BRANTFORD.**—The Dominion Steel Products Co., Ltd., are the manufacturers of the first Diesel engines completely designed and built in Canada.

**COLLINGWOOD.**—The Collingwood Garage has installed a plant for re-charging Ford magnetos. They have also installed a plant for re-babbiting of engines.

**BRANTFORD.**—H. W. Hutchinson, vice-president of the Sawyer-Massey Company, of Hamilton, has been elected a director of the Cockshutt Plow Company.

**ST. CATHARINES.**—Llewellyn Hall, of Hall Bros., implement dealers, has been elected president of the recently organized Ontario Implement Dealers' Association.

**PORTLAND.**—Michael White, a Portland farmer, while driving a threshing machine fell under the engine, breaking one leg and badly bruising the other.

**RENFREW.**—The Chevrolet Motor Sales Co. have opened a show room and service station here. They handle repairing and a complete line of auto accessories and tires.

**LISTOWEL.**—The Canadian Farm Power and Machinery Co., Ltd., has been formed with \$500,000 capital for the manufacture of oil engines and agricultural implements.

**PETROLIA.**—Messrs. Fred. Bowen and Jas. Columbus have purchased the Overland Garage formerly conducted by T. Burnard. They handle autos, repairs and farm machinery.

**TORONTO.**—The Machine and Stamping Co., Ltd., 1209 King Street, changed its name on Oct. 1 to the Russell Gear and Machine Co., Ltd. without changing the management.

**LONDON.**—The Stansell Motors Company has purchased a 35-acre site in East London, along the line of the G.T.R. where operations on a new factory plant will be commenced at once.

**BEAVERTON.**—Smith Bros. have installed an oxy-acetylene welding outfit and will do all classes of machinery and other cast-metal welding. They are agents for Sharples cream separators.

**ST. THOMAS.**—While threshing was in operation at the farm of W. Graham, of Melbourne, recently the boiler of the threshing machine exploded, causing damage estimated at \$3,000. Nobody was injured.

**AGINCOURT.**—The Ontario Motor League will erect "speed limit" signs at either end of this town in the near future. The citizens of the town have lodged several complaints against motorists for speeding.

**TORONTO.**—Cyrus Jones, who has been with the Regina branch of the J. I. Case Threshing Machine Co., has been transferred to the Toronto branch where he will be an instructor in the Case service school to be started soon.

**KITCHENER.**—Specimens of the Dominion tires, made here, used on the motor cars ridden by H.R.H. the Prince of Wales during his Canadian tour are being shown in the window of the G. T. R. office in Cockspur Street, London, England.

**OWEN SOUND.**—W. J. McKerrell, of Sydenham township, lost his right hand recently while threshing. He put his hand into the blower to pull out some straw that was choking the machine and the suction drew his hand into the cutter.

**BRANTFORD.**—The Brantford Machine and Tool Company, Ltd. has just been incorporated to continue and add to the former business of the Brantford Machine and Tool Co. They intend to extend and manufacture a line of garage equipment.

### QUEBEC

**THREE RIVERS.**—The first snow of the season in Quebec fell in Three Rivers on Oct. 29.

**MONTREAL.**—Dunwin Motors has been incorporated to buy, sell, trade in and make motors, autos, etc. The capital is placed at \$100,000.

**COATICOOK.**—Bachand & Dionne, automobile and power farming dealers, have done a large business this year in autos, trucks, tractors and implements.

**MONTMAGNY.**—The National Farming Machinery Co. is making additions to its factory and is planning to manufacture all kinds of farming machinery.

**PORT ROUGE.**—La Compagnie Chs. A. Julien Ltd. has been authorized to do business in Ontario with a capital not exceeding \$40,000. This company manufactures gasoline engines, threshing machines and implements.

**ST. ANNE DE BELLEVUE.**—The annual plowing match and tractor demonstration, under the auspices of the Eastern Ontario and Western Quebec Plowmen's Association, was held at Macdonald College Farm, Oct. 12-14.



**CASE**  
POWER FARMING  
MACHINERY

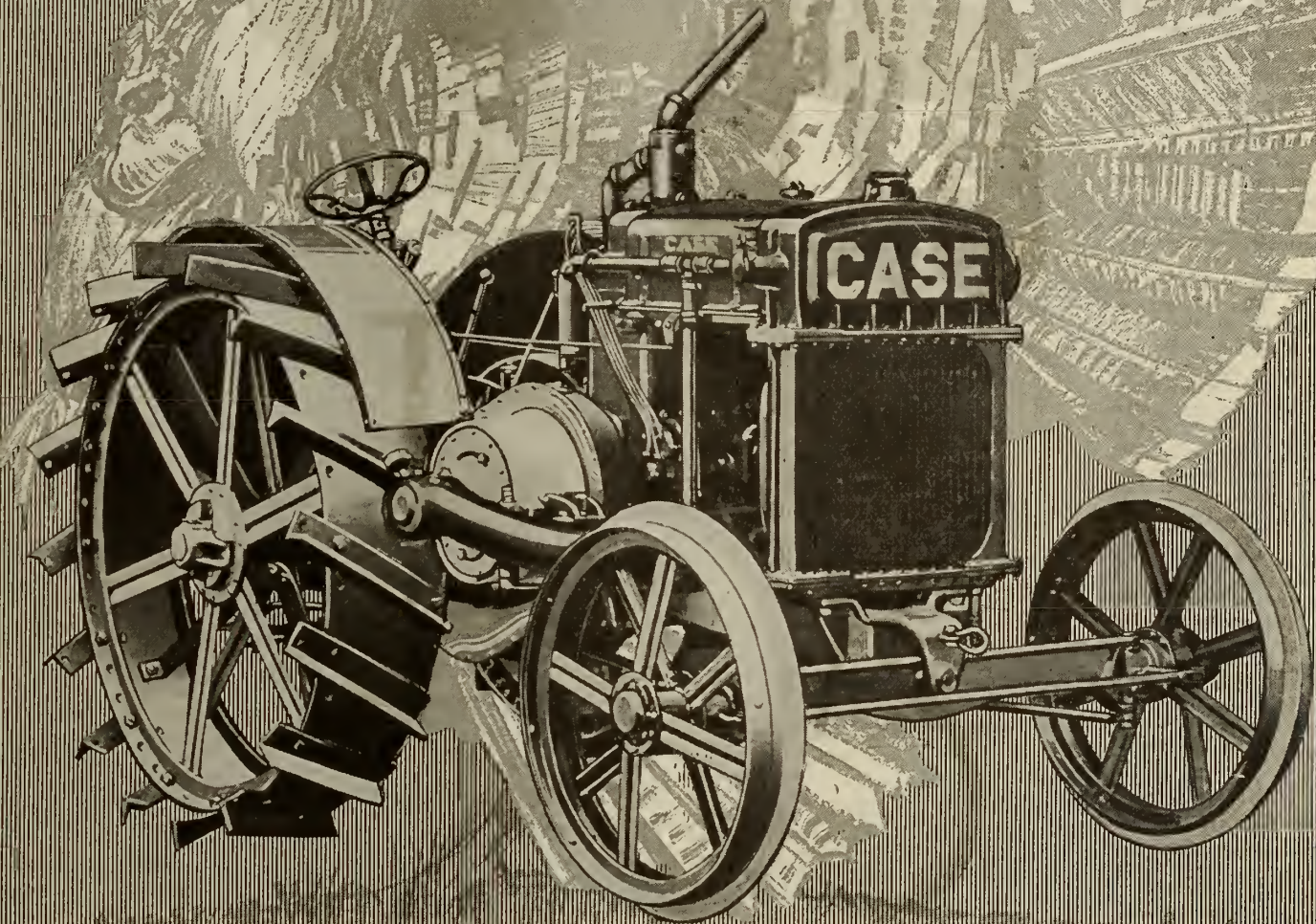

**“I thank you-all—”**

Into the daily work of our dealers, selling the great line of machinery that serves our customers in every corner of the civilized world, there often comes a sincere word of appreciation that adds to the satisfaction of selling *“the best machinery on earth.”*

A typical letter, fairly representative of thousands of similar expressions, follows:

“With the separator we got from you-all in 1919, we have threshed 150,000 bushels. \* \* \* We are finishing up on a 9,000 bushel job, held for us on account of our J. I. Case separator doing its good work. I think it is one of the best threshing machines made.

“I thank you-all for the best machinery on earth.

Yours truly,

Horlacher Bros. By-Sam.”

For the generally cordial relations existing between the sellers and users of our great line of power farming machinery, we too, are thankful.

**J. I. CASE THRESHING MACHINE COMPANY**

(INCORPORATED)

345-9 DUFFERIN ST., TORONTO, ONT.

Dept. O-11

Making Superior Farm Machinery Since 1842



Look for the  
EAGLE  
Our Trade Mark

**NOTE:**

We want the public to know that our plows and harrows are NOT the Case plows and harrows made by the J. I. Case Plow Works Co.

To avoid confusion, the J. I. CASE THRESHING MACHINE COMPANY desires to have it known that it is not now and never has been interested in, or in any way connected or affiliated with the J. I. Case Plow Works, or the Wallis Tractor Company, or the J. I. Case Plow Works Co.



# Automotive Accessories and Implement Equipment

## PROTECTOMETER FOR TRACTORS

THIS is a simple, strong, spring release hitch for tractors that also indicates pounds pull. The protectometer dial shows what power the tractor is pulling; releases the tractor from the implement when the farmer overloads and can be set to release at the desired point. It is installed between the draw bar and the implement. The makers claim it absorbs all shocks right at the draw bar and reduces to a minimum the wear and tear on the tractor, mechanical parts, and implements. It is made of cast and spring steel and weighs less than 20 pounds. It is accurate, requires oiling only once a year, and is practically indestructible.

The protectometer dial indicates up to 6,000 pounds pull. The release is a very important feature of the protectometer. In the Fordson this has been determined by tests and will release at 3,400 pounds. For other than Fordsons the Model "C" protectometer can be set to release for 2, 3 and 4 bottom plows at 4,000, 5,000 and 6,000 pounds draw bar pull, which is the average maximum pounds pull that should be exerted by the tractor before releasing.

On sudden impact, as when the plow strikes a solid obstruction or when a terrific strain is put on the tractor beyond the fixed pull, the protectometer releases the hitch by means of a clevis. The annoyance of shearing wooden pins is removed and the tractor is protected against serious damage. The manufacturers are the Protectometer Company, 814 Hearst Bldg., Chicago.

## "H B" MOTOR GRINDER

THIS is a strongly constructed motor grinder driven by dust proof ball bearing equipped motor for use in the repair shop for grinding castings, sharpening tools, tire buffing, etc., etc. The makers say it is heavily constructed throughout to stand under the heaviest kind of work. The grinder is furnished complete as shown in illustration less the grinding wheels. The shaft is one inch in diameter, length thirty-six inches, weight 275 pounds. The floor space required is 20x36 inches. Made by Hobart Brothers Company, Troy, Ohio. The Canadian distributor is the Battery Service and Sales Co., 113 King Street W., Hamilton, Ont.

## HALBURN ADJUSTABLE REAMER

THIS adjustable reamer is for valve seats. It is quickly adjusted and set to dimensions by the turning of two nuts. The makers say the adjustment ranges from 1 1-16 inches to 2 1-2 inches. The cutters are made of hardened and tempered tool steel and slide in slots having a 45 degree base. Pressure of the cutters on the valve seat drives them against this base, thereby giving same effect as a solid tool and preventing the cutters from getting out of alignment. The pilot stems are interchangeable.

The tool can be lowered through a porthole and expanded after it is inside the port.

It is manufactured by Halburn Company, 317 West Pico Street, Los Angeles, California.



Protectometer

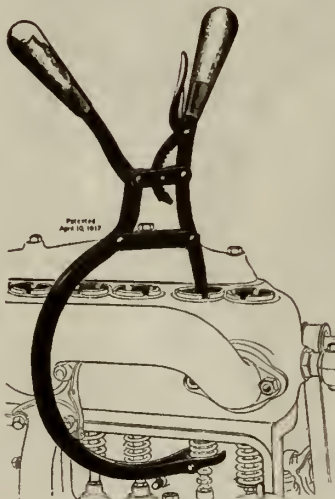

Perfection Valve Lifter



"H. B." Motor Grinder.



Peters Metallic Filler



Halburn Reamer



New Arbor Press

## PETERS METALLIC FILLER

THIS is designed for speedy and permanent repairs of scored and cracked automobile cylinders. It is a brass composition, the makers state, which becomes plastic at 300 degrees and at this low temperature entirely eliminates the possibility of warping and distorting the casting.

It adheres quickly and permanently to cast iron and other metals. After it is applied it has all the qualities of brass, including hardness, density and a tremendous heat resistance. It can be machined and in scored cylinders will sustain any piston speed. It will withstand a pressure of 150 pounds per square inch. It is worked while plastic and not in the molten state.

The makers are the Aluminum Brazing Solder Co., Widener Bldg, Philadelphia, Pa.

## NEW ARBOR PRESS

THE National Engineering Co., Ltd., Sarnia, Canada, have placed on the market a new arbor press, an illustration of which is shown.

Instead of using the old "goose neck," a "three-point" construction with a direct strain is adopted. The machine, neatly finished, is of light weight and occupies the small floor space of 20 inches.

Some of the features of superiority in this three-ton press are as follows: It has a 36-inch range, which makes it a very useful tool in garages for removing gears, etc. It also has an adjustable table with nine openings on the dial, and a ratchet wherein the strain is placed on all the teeth instead of one tooth. The machine has a capacity of 16-inch diameter. The A. R. Williams Machinery Co. are selling agents for the "Necco" line.

## PERFECTION VALVE LIFTER

THIS valve lifter in action is quick, positive and effortless. The makers claim that one man can operate it with ease on any T or L head gasoline engine. A slight pressure compresses the stiffest valve spring. It is designed so that the action is all above the cylinder heads, yet overhead manifolds, piping and overhanging dashes do not interfere. It imposes no side strain. The jaws move in a line directly perpendicular with the plunger point, which rests on the centre of the valve head. The adjustable jaws fit all sizes of spring retainers. The valve spring when compressed to the point desired is automatically held in position. The operator's hands are left free to remove the retaining pin or washer. The lifter is built of steel forgings and is very durable. The makers are Porter Incorporated, San Diego, California.

## APCO GASOLINE RESERVE FOR FORDS

THIS device holds 1 gallon of gasoline in reserve, which can be used by throwing a spring valve over a quarter of a turn. When the reserve supply of gas is used, the tank cannot be filled until the valve is reset, which is done by turning back to its original place. It is installed through the filler cap and no tools are required. It is manufactured by the Apco Mfg. Co., Providence, R.I.



**START YOUR CAR WITH  
POWER FROM NIAGARA**

**USL  
STORAGE BATTERIES**

**USL  
TYPE  
CDC-311-7**

### Machine-Pasted Plates

**T**HE life of a Battery depends upon the durability of its Plates. The active material, or "paste," is squeezed by powerful machines into the grid of each USL Battery Plate, forming a solid, homogeneous mass from face to face. These USL MACHINE-PASTED PLATES are full formed and charged with Power from Niagara, and make the USL Battery long-lived and thoroughly dependable.

Nineteen C.G.E. Sales Branches from coast to coast carry USL Storage Batteries. This Dominion-wide service is at your disposal.

*"Tested for Service."*

**Canadian General Electric Co., Limited**

Head Office

TORONTO

Branch Offices: Montreal, Quebec, Sherbrooke, Halifax, Sydney, St. John, Ottawa, Hamilton, London, Windsor, Cobalt, South Porcupine, Winnipeg, Calgary, Edmonton, Nelson, Vancouver and Victoria.



**BADGER SPRING BAR BUMPER**

THE Badger Mfg. Co., Milwaukee, Wis., has just put on the market its new spring bar bumper, for which it claims special features. The main bar is in one piece, and is reinforced by an additional length of spring steel. The method of adjustment is such that it will take care of any width of frame, being made between main bar and frame brackets. The steel clamp holds the two sections securely together, preventing rattle.

The Badger people state this bumper can be equipped on the front of sixty-seven cars and on the rear of forty-two cars. It is made in single and double bar types in all black or nickel finish. The double bar type in the nickel frame has the main bar and brackets finished in black and the reinforcing slab in nickel. The makers claim that riveting the reinforcing slab to the main bar prevents vibration and eliminates the rattle that often occurs when sections are simply clamped or bolted together.



Lucia Auto Lock

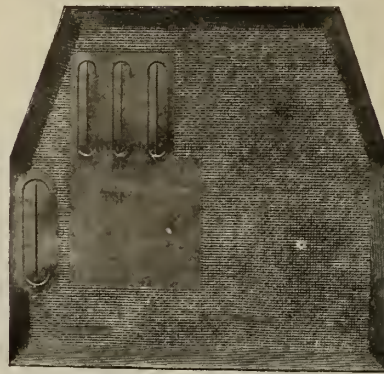

Auto Mat

**ADJUSTABLE WRENCH**

THE Allen-Diffenbaugh Wrench & Tool Co., Baraboo, Wis., have marketed an adjustable wrench which automatically grips a nut when the handle is pulled. It is made in several sizes from drop-forged steel and has jaws that are machined and hardened.

**KOPP'S LENS**

THE new Kopp's emerald tint automobile lens is designed to meet all the requirements of the Anti-Glare Law yet giving a powerful enough ray to drive under all conditions. It is one of the approved lenses listed recently by the Ontario Department of Highways.

The makers claim that Kopp's lens bends the light from an automobile headlight downward, keeping it below a 42-inch level, 75 feet from the automobile. It also distributes the light, illuminating the roadway to a width of 27 feet. The control over the natural spread of the light beam is accomplished by two sets of deflecting prisms which are mutually intersecting and form a multiplicity of triangular shaped prisms which bend the light downward and sideways. This arrangement allows the lens to be divided into triangular shaped areas in which the prisms may have any refracting power desired.



Kopps Lens

The glass used in Kopp's lens is an optical glass specially developed to meet the requirements of headlight lenses. It allows the greenish-yellow rays to pass, but a comparatively small per cent. of the red or blue. These greenish-yellow rays are the ones to which the eye is most sensitive, while the red and blue add little to the visibility and are the cause of the objectionable glare.

The makers are the Pittsburgh Lamp, Brass and Glass Co., Pittsburgh, Pa. The Canadian representative is R. E. Davis, 113 Wortley Road, London, Ontario.

**J AND B VALVE CAGE REMOVER**

THIS tool is designed for the removal of valve cages on all makes of valve-in-the-head motors, having a 2 1-8 inch cage. It is made of a high grade steel and drop forgings. The makers say it is easy to operate, is self-adjusting, positive in action and will pick out any valve. It draws the cage out true and makes the bending of valve stems impossible. It is finished in rust proof and will withstand severe usage.

It is manufactured by the J and B Manufacturing Company, Pittsfield, Massachusetts.

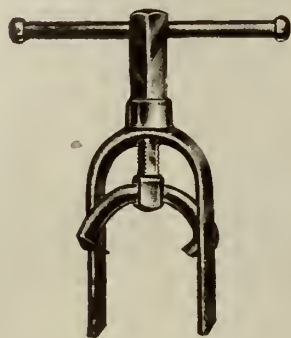

Valve Cage Remover

**MOTOR GRIP TRANSMISSION LOCK**

A NEW lock suitable for all makes and models of Ford cars has been put on the market by the Wright Accessories Corporation, Atlanta, Ga. It is claimed that this lock can be installed by the car owner in less than ten minutes, and one turn of the key from the seat locks the transmission, motor, gasoline, and crankshaft in an unbreakable grip. Keys will only open the one lock to which they are fitted. The lock is in a 12-gauge steel housing and when fastened a steel cam grips flywheel, making movement of car impossible until the right key is used.

It is stated that this lock has been subjected to the severest tests and fully approved by the underwriters' laboratories.

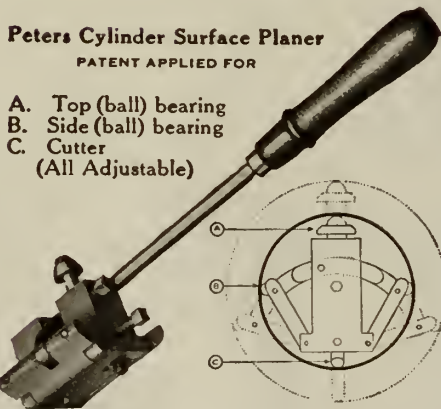

Cylinder Surface Planer

Peters Cylinder Surface Planer  
PATENT APPLIED FOR

- A. Top (ball) bearing
- B. Side (ball) bearing
- C. Cutter (All Adjustable)

**NEW AUTO MAT**

THE Gutta Percha Mfg. Co., Ltd., Toronto, Ont., are manufacturing a mat suitable for all Ford cars. It is constructed of rubber, and, as shown by the illustration, fits over the brake levers and transmission gears, keeping out dust and heat from the engine in the summer time and protecting the driver from the cold winds which usually find their way through these openings during the cold weather.

The flaps fit snugly over holes in the bottom of the car and at the same time do not in any way interfere with the workings of the levers or brake.

**LUCIA AUTO LOCK**

THE Lucia Mfg. Co., 1123 Broadway, New York, have placed on the market a new theft-proof auto lock.

The makers say the lock, which is attached to the emergency brake, can be fitted to any car in a few minutes without the aid of tools. All that is necessary when leaving the car is to throw the gear shift lever into reverse and snap the lock shut. In this position the car cannot be driven or towed. A key has to be used to release the lock. The lock is a four tumbler Corbin, which, it is stated, no master key will fit.

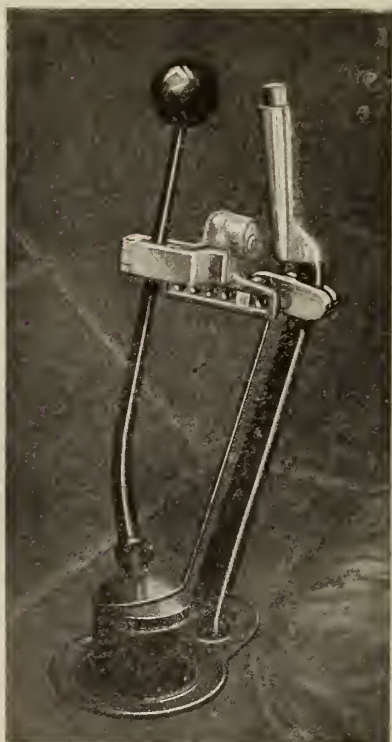

Motor Grip Transmission Lock

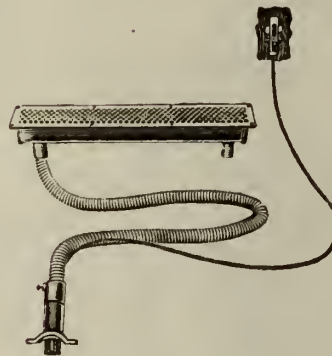

Register Type Heater

**GILMAN SHOCK ABSORBER**

IN principle and operation the Gilman shock absorber affords an ideal method of shock absorption, say the makers, for it controls the springs' recoil the full distance of its travel. While permitting the springs to perform their intended function to the limit of their efficiency under normal road conditions, it prevents abrupt or violent movement when road conditions change from normal. Like the spring itself, it is placed between the body and the axle. It is manufactured by the Gilman-Davis Mfg. Co., 224 South Michigan Avenue, Chicago.

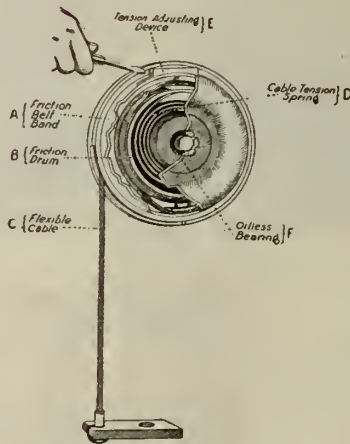

Gilman Shock Absorber

**REGISTER TYPE HEATER**

THIS heater is designed, the makers say, in answer to a demand by motorists who prefer a high-grade, light, simple heater properly sunk beneath the floor. All that shows above the floor is the register which is nickel-plated. The control, which can be operated with one finger, is conveniently located at the driver's seat, or in the tonneau if so desired. The heater is made in two sizes to fit all cars. Manufactured by the Hill Pump Valve Co., Chicago.

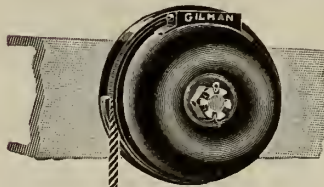

**CYLINDER SURFACE PLANER**

PETERS cylinder surface planer is a tool for finishing off the excess metal from a scored cylinder repair in perfect cylindrical alignment. It is instantly adjustable to all sizes of cylinders and performs the operation in not more than ten or twenty minutes.

It is made by the Aluminum Brazing Solder Co., Widener Bldg., Philadelphia, Pa.

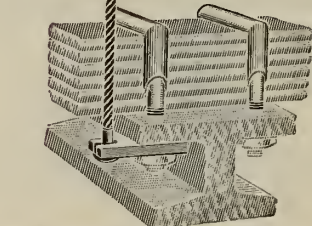

Gilman Shock Absorber



# Equal to Any Task



Just pump the handle —it takes care of the load. You can safely recommend for replacement use any of our improved

## NIAGARA JACKS

We make six jacks for you to select from with capacities for any make of car or truck. Packed in individual cartons with guarantee against breakage under rated load.

*Illustrated booklet and price on request.*

*Makers of the famous "Lyon" Bumpers.*

**Kinzinger, Bruce & Co., Limited**  
 NIAGARA FALLS, ONTARIO

# The Plug with the Hotter Spark



The ball point of the "M&S" spark plug concentrates the current and intensifies the heat. This gives a sure, hot spark—producing better combustion and greater power.

The "M&S" plug is made in all styles to suit every make of car—it is standard equipment on the popular new Overland "4."

The "M&S" plug is made in Canada and guaranteed to give complete satisfaction.

**Dealers:**—Ask your jobbers for the "M&S" plug.



## SPARK PLUGS

*"Made-in-Canada"*

No.	Models
500—1/2"	Standard
501—3/8"	Standard
502—7/8"	Long
503—7/8"	Long with Chevrolet Terminal
506—1/2"	Long
504—Regular	Porcelain
505—Chevrolet	Porcelain

**Machine & Stamping Company, Limited**  
 1209 King Street West, Toronto, Ontario  
 Commercial Dept., Russell Motor Car Co. Limited

# Satisfaction Guaranteed

YOU would suppose that a concern which won its reputation on the quality of its products would be content to rest upon its laurels. Not so the makers of

# "HEXALL" Socket Wrenches

Trade Mark Reg. U.S. Pat. Off.

"Keep Faith"—they say, "with the tens of thousands who rely upon the un-failing dependability of the best socket wrenches in the world. Make Assurance of Quality Doubly Sure."

Therefore, every "HEXALL" that goes to the shipping room carries this guarantee:—

**"Break Any Sedgley Wrench and We Repair It—No Charge"**

—a policy that Guarantees Satisfaction and makes the sale of a "HEXALL" the quickest and easiest sale you can make. "HEXALL" is there in every sense of the word—you know it—and if, for any reason, it doesn't "make good," the guarantee will. *There are 7 Sets—a "HEXALL" for every need.*

Here is the most practical, reliable, small revolver on the market—"BABY." It measures but 4 inches overall; weighs only 6 oz. and shoots 6 .22 caliber, short, rimfire cartridges.

DISPLAY IT!

**R. F. SEDGLEY, Inc. Est. 1897**

2311-13-15 North 16th St., PHILADELPHIA, PA.

Canadian Distributors: Lamontagne, Limited, Montreal, Canada.  
 Harold F. Watson Co., Sole Agent: 208 Coristine Bldg., Montreal, Canada.



"HEXALL" Ratchet Socket Wrench No. 1—16 pcs.



"HEXALL" Ratchet Socket Wrench No. 2—11 pcs.

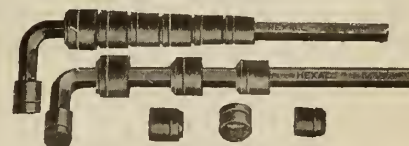

Patented Dec. 31, 1918  
 "HEXALL" Socket Wrench No. 5—8 pcs.

The "BABY"

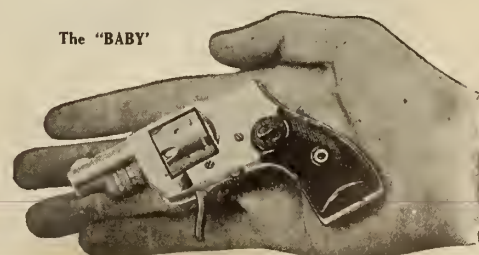



## A 24-Hour Radiator Repair Service



Why fuss with troublesome radiator repairs? They can be more cheaply and effectively executed by the manufacturer.

Ship any make to our Repair Department and in 24 hours, or less, it will be on its way back to you—freight or express as you instruct.

We promise you no wait service and A No. 1 workmanship.

**McCORD MFG. CO.**  
WALKERVILLE, ONTARIO

WE GIVE

# “Quality and Service”

IN

## TRACTOR and TRUCK STEEL CASTINGS

### Joliette Castings & Forgings Limited

Head Office: **Transportation Bldg., Montreal**      Works: **Joliette, Que.**



## It Docks at Your Desk

Our service brings to your desk news items collected from the newspapers relating to your line of business.

Often you plan your affairs on market conditions or new developments, but you could plan much better with all information before you from the whole of Canada.

These newspaper clippings have proved most valuable to business houses, saving time in searching files and often being turned to good account, getting contracts and orders. We cover all parts of Canada and United States and read for all subjects discussed in the press.

Have the news packets arrive regularly at your desk with a cargo of timely news.

**Canadian  
Press Clipping Service**  
143-153 UNIVERSITY AVE., TORONTO

# WESTERN NOTES



## BRITISH COLUMBIA

**MARPOLE.**—The Murray Motors, Limited, is the name of a new garage opened here.

**NEW WESTMINSTER.** — Messrs. Mills and Brown are operating an up-to-date Ford service station and auto livery.

**NELSON.**—The Nelson Hardware Co. report that the farm machinery department of their business has been exceedingly good during the past year.

**NEW WESTMINSTER.**—The Sigmore Motors has changed hands. The new owners are Gregg, Ralston and Hockly, Limited. They have the agency for Studebaker and Gray-Dort cars.

**PORT COQUITLAM.** — Owing to labor troubles in East and South, delivery of the machinery for the new tire and rubber factory was held up for some time. Mr. Gregory, president of the company, says practically all the machinery is now on hand and he assures the city council that the factory will be under production soon.

## ALBERTA

**STRATHMORE.**—A vulcanizing and accessory business has been opened here by Messrs. West and Forbes.

**HANNA.**—J. W. Mockett has acquired the Boyd Bros. Garage. He has the Ford agency and handles all repairs.

**RYLEY.**—What is styled as the finest Alberta garage in Northern Alberta is being operated here by Mr. Young.

**INNISFAIL.** — Dundas and Oxley, implement and tractor dealers, have dissolved partnership. Mr. Dundas will carry on the business.

**REDCLIFF.** — Messrs. Moses and Kitchen are now operating the garage known as the City Garage and are handling repairs, oils, gasoline and tires. They also supply a jitney service.

**CAMROSE.**—A new business will be opened here shortly by J. Pollock from Savannah, Georgia, for the manufacture of auto tops and for upholstering of automobiles.

**BROOKS.**—Marshall Hardware Co. recently completed a new garage for handling Ford cars and Fordson tractors. The building is modern in every way and is equipped with up-to-date machinery for all kinds of repairs.

## MANITOBA

**WINNIPEG.**—The Western Truck Body Co. has been recently incorporated.

**RIDGEVILLE.**—R. A. Laufensweiler, Cockshutt dealer, has built a new shop 30x50 feet.

**STEINBACH.**—P. S. Sprung has purchased the garage and implement business formerly conducted by Messrs. Rempel and Toews.

**WINNIPEG.**—W. J. Fulton, manager of the Dominion Radiator Company, has been appointed member of the Joint Council of Industry.

**BRANDON.**—The Imperial Oil Co. are planning to have all the buildings on their property here removed this fall in order that an early start may

be made in the spring on their \$300,000 plant.

**WINNIPEG.**—The Cuthbert Co., 408 Corn Exchange, Minneapolis, Minn., have made arrangements for manufacturing and selling their line of farm equipment in Western Canada. They have opened a branch office at 118 Grain Exchange.

**MARGARET.**—The main portion of the village of Margaret was wiped out by fire recently, according to a Canadian Press despatch. The fire, which is believed to have been of incendiary origin, destroyed eight buildings, as an estimated loss of \$25,000.

**WINNIPEG.**—The Gardiner Cultivation Company, Limited, with a capital of \$500,000, has been formed to take over the rights of and manufacture the Gardiner rotary cultivator. This machine has been on the market for three years and is giving satisfaction.

## SASKATCHEWAN

**SHAUNAVON.**—S. S. Lee has sold his implement business to A. A. Hassard.

**SASKATOON.**—Cassidy and Co. have erected a new fire-proof garage 41x55 feet.

**TURTLEFORD.**—The garage formerly run by W. R. Plain has been taken over by J. Miller.

**WELWYN.**—J. Clearwater has purchased the implement business formerly conducted by C. H. McDonald.

**SWIFT CURRENT.**—The Kirkaldie Garage, dealers in automobiles, accessories and farm implements, suffered losses from fire recently.

**ASSINIBOIA.**—Messrs. B. A. Campbell and H. Shaw, who recently formed a partnership, have secured the Ford agency for Assiniboia and district.

**REGINA.**—An action to collect \$10,150.43 from the Ryan Motors, Ltd., was entered in the Court of King's Bench on Oct. 6th by counsel for Thos. H. G. McVean Co., Ltd., contractors.

**SASKATOON.**—The Imperial Oil Co., Limited, plan to erect an office and service station to be located at Twentieth Street and Third Avenue. It will cost in the neighborhood of \$50,000.

**REGINA.**—The Imperial Oil Co., Limited, and the Great West National Gas Corporation, Limited, have entered into an agreement for the development of the Saskatchewan natural gas and oil fields. Both companies will carry on operations.

**YORKTON.**—A. E. Donovan, formerly manager of the Cushman Works of Canada, Winnipeg, has purchased premises here and will carry a full line of implements, including Advance Rumely tractors, Cockshutt plows and the Cushman line.

**HUMBOLDT.**—Kelly Bros. have erected a new garage and show room where they will carry on a complete automotive business. The workroom is equipped with the latest machinery. They handle Dodge, Gray-Dort and Chevrolet cars, Case tractors and threshing machines and Fairbanks-Morse lighting plants.

**LANCASTER, N.B.** — The Ford Motor Company will build an assembling plant here.



**BIG INCREASE IN CANADA'S IMPORTS**

ACCORDING to a Canadian Press Despatch, Canada's imports of both free and dutiable goods show an increase for the 12 months ending August, 1920, as compared with the 12 months ending August, 1919, and August, 1918. The Dominion Bureau of Statistics issues the following trade summary covering the period:

Dutiable goods, 12 months ending August, 1918, \$516,484,137; 1919, \$537,000,391; 1920, \$850,743,841. Free goods, 1918, \$386,373,813; 1919, \$335,267,503; 1920, \$445,408,523. Total imports, merchandise 1918, \$902,857,950; 1919, \$872,267,894; 1920, \$1,269,152,364. Duty collected 1920, \$155,502,162; 1919, \$155,477,445; 1920, \$210, \$210,825,984.

Canada's total exports of merchandise were lower during the 12 months ending August this year than in the two 12-month periods previous. This was probably due in large measure to the reduction of war orders. The summary gives the following value of exports: 1918, Canadian, \$1,334,972,342; foreign, \$41,190,665; 1919, Canadian, \$1,241,615,581; foreign, \$59,812,687; 1920, Canadian, \$1,219,523,896; foreign, \$37,918,443. The totals for the three periods were: 1918, \$1,367,163,007; 1919, \$1,301,428,368; 1920, \$1,257,442,339.

The purchases by Canadians from the United Kingdom during the 12 months ending August, 1920, reached the total of \$206,107,122, against \$76,690,228 in the 12 months previous. The imports from Australia fell off from \$4,599,824 in the 12 months ending August, 1919, to \$1,641,852 in the period ending August, 1920. Purchases from the British West Indies, Cuba and France, showed notable increases during the most recent period. From the former Canada purchased \$16,519,227 worth of goods in the period ending last August, as against \$10,337,756 during the year previous. From Cuba the imports reached a value in 1920 of \$33,661,564, as compared with \$5,285,708 in the 12 months ending August, 1919. Imports from France increased in value from \$4,420,078 in 1919 to \$18,670,509 in 1920.

Our purchases from the United States in the period ending August, 1920, increased to \$904,115,329, as against \$692,606,973 in the previous corresponding period.

**REORGANIZATION OF BEAVER MOTOR TRUCKS**

IT was announced recently that the American Axle Company, capitalized at \$6,000,000 has become heavily interested in the Beaver Motor Truck Corporation, of Hamilton, Ontario, and in future would supervise the operation of the Hamilton factory. H. R. Williams, who organized the original Beaver Truck Company, will be president and general manager under the new arrangement, with E. W. Macavoy, president of the Axle Company, as vice-president and Captain H. Trenaman as treasurer.

The directors are W. Mulvaney, E. D. Stares, W. H. Dawson, of the T. Eaton Company, P. C. Wolf and P. J. Schultz, of the American Axle Company.

**SHINN-FLAT PROTECTS PARLIAMENT BUILDINGS**

THE Shinn Manufacturing Co., of Guelph, manufacturers of Shinn-Flat lightning rods have been entrusted with the work of installing adequate lightning protection for the new Parliament Buildings at Ottawa. The work is under the personal charge of Professor W. H. Day, formerly Professor of Physics at the Ontario Agricultural College, now secretary-treasurer of the Shinn Mfg. Co., of Canada. It is estimated that several thousand feet will be required to give a complete system for the intricate features of the build-

ings. The buildings have some twenty odd chimneys and about a dozen towers, the highest now completed being 140 feet. The main tower will be over 300 feet in height.

**MONTREAL MOTOR SHOW**

A. LEVESQUE, Active Secretary of the Montreal Automobile Association, has announced that the annual Montreal Motor Show will be held from January 22-29, 1921, at the Motordrome Building, 228 Sherbrooke Street East.

It is expected that all the Canadian and American automobile manufacturers will be represented. Most of the manufacturers have already enquired about space and enquiries have been received by the secretary from European firms anxious to exhibit. This will be the only official motor show held in Montreal this year.

**CEMENT TO STOP LEAKS IN FUEL TANK**

DURING the war numerous experiments were made with the object of securing a means for easily and quickly closing rents in gasoline tanks. Toward the end of 1916 the testing laboratory of a French technical school was requested to analyze and test a special putty, called Ob. The analysis gave the following results:

Soaps—	Per cent.
Fatty acids .....	17.05
Alkalies .....	3.60
Glycerine .....	4.00
Water .....	21.45
Various mineral materials .....	53.90
	100.00
	Per cent.
Clay .....	95.20
Lime .....	3.00
Magnesia .....	0.40
Sulphuric acid .....	1.40
	100.00

In order to determine how this putty behaved under the influence of vibration, a 40-gal. tank was mounted on a light motor truck. Nine holes were punched in it, varying in diameter from 0.4 to 0.8 in. and located at different heights. These holes were closed up by means of plugs made from the paste or putty under test.

The truck was driven a distance of 34 miles over bad roads at an average speed of 13 m.p.h. A single crack formed in one of the plugs and this was stopped by applying more of the putty. After 23 hours of testing there was no oozing out of liquid at any of the plugs and the conclusion was reached that this putty or cement may render great services in stopping leaks in fuel tanks.

**CLETRAC HEAD OFFICES MOVED**

THE Cleveland Tractor Company, of Canada, Limited, are moving their head offices from Windsor, Ontario, to Number 21, Ottawa Street, Montreal, Quebec, on November 1st, at which time their new headquarters, now under course of construction, will be completed. It has been decided that Montreal is a better distributing centre for Eastern Canada than Windsor. The object of the company is to endeavor to give its owners a 24-hour service. The establishment of their Western Branch at Regina, Sask., enables them to give this service in Western Canada.

THE ending of the moratorium is said to be causing the sale of many automobiles. Money is required for mortgage purposes. But the automobile habit is one that sticks, and when the crisis is over the sales will probably have created a new market for automobiles.



## A Perfectly Sealed Firing Chamber

There can be no lost power where Excellence Two-Piece Piston Rings are used. They seal tight—absolutely.

Examine an Excellence Ring and you will be at once struck with the simple and positive action. The two pieces are so fitted together that they will readily contract or expand as necessary, **but will always be tight.** No gas, oil or compression can pass, all power must be exerted on the piston head.

These sizes of Excellence Rings are now available: 3 3/4 x 1/4, 3 3/4 x 3-16 and 3 11-16 x 3-16. Other sizes will be ready soon.

Manufactured exclusively and distributed by

### EXCELLENCE TWO-PIECE PISTON RINGS

**Lamontagne Limited**  
*Wholesale Dealers in Automotive Equipment*  
Quebec Montreal Winnipeg

*The Only Perfect Piston Ring*



# PERFEX

## The Perfect Radiator

Perflex radiators for Fords are a quality product embodying features that cannot be had in other radiators. A patented spring bracket suspension and a real radiator core of great efficiency.

*The last word in Radiator construction*

**Perflex Radiator Co., Racine, Wisconsin, U.S.A.**

P. A. C. McINTYRE & COMPANY  
311 Confederation Life Building, Winnipeg  
Direct Representatives for  
Manitoba, Saskatchewan, Alberta and British Columbia



# The Inaccessibility of Some Tractors

By L. G. HEIMPEL, B.S.A.

IT is only after many time-losing, character-testing and patience-destroying experiences in the performance of many tractor repairs in which the one thought which would always be coming up was, Why don't designers at least think of accessibility when designing a tractor? that the writer was moved to write this article.

That the average tractor firm, and the average tractor buyer, have not realized the importance of accessibility of all parts of the machine is clear to me because if the former would see the importance of it he would use it in the headlines of his every advertisement. As for the user—well, the average user knows nothing about his own or any other tractor until about the middle of the second or third year when he comes to the same conclusion which it took the writer nine years to arrive at, namely, that on many tractors many parts are hopelessly inaccessible. However, not all designers are blind to this important feature in tractor construction. We realize that to design a machine which will stand up to what is demanded of a present day tractor, which will have all modern equipment and appliances which go to make the machine one of easy operation is no small task, yet, even the writer who has studied design only from the user's viewpoint could without trouble design an engine which would be a model of accessibility in comparison with some of the mechanical monstrosities we occasionally have to deal with.

## Specifications of Average Tractor

In order to make clear what we mean by an accessible machine let us take as an example the list of specifications of an average tractor, which is as follows:

- Name—
- Normal capacity—3 plows; 22 inch by 36 inch thresher.
- Rating—10-20.
- Traction—Two rear drivers size—; 2 front wheels—.
- Dimensions:—Length, —, width, —turning radius.
- Motor—Own, No. of cylinders,—bore —, stroke—, case in block, number of rings to piston and their width.
- Lubrication—Nature of it.
- Cooling—Radiator, pump circulation, fan, cooling fluid, water.
- Ignition—Dixie magneto, impulse starter, Rajah plugs.
- Governor—Own, centrifugal enclosed.
- Carburetor—Own, size—.
- Air cleaner—Dry type.
- Clutch—Expanding shoe.
- Transmission—Own, (No. of speeds and miles per hour of each).
- Bearings—Roller bearings.
- Final Drive—.
- Pulley—Size—, driven direct.

## Another Specification

This example of a list of specifications, it is true, tells a great deal about an engine. But after two years of use the following is what we should like to add to some of the specifications of certain engines:

- Name—.
- Normal capacity, 10-20.
- Traction—Two rear drivers, size—, lugs of such a type as will require two men over half-a-day to attach or remove.
- Motor—Own, so placed that to get at most parts of it necessitates the removal of the rest of the engine. Number of main bearings two, to adjust one of which necessitates the removal of a drive wheel, which requires a jack and twenty feet of heavy logging chain or a wheel puller and a half day's time, the removal of clutch spider, pulley, gear case housing cover, first reduction gear set and gear housing—when lo and behold! the bearing. This can now be adjusted in twenty minutes after which it takes two men another day

*Readers of M.T.I. who sell tractors will be interested in this article. Mr. Heimpel is head of the farm engineering department at the Agricultural College, Kemptville, Ontario. He has had considerable experience with tractors and all kinds of farm machinery, and anything he has to say on the operation, design or construction of such machines commands attention.*

*Needless to say, M.T.I. is not responsible for the views herein stated but is desirous of getting the opinions and views of its many tractor and power farming readers. If you have anything to say on this or any other like subject, shoot your opinions along; they may be valuable to the industry.*

—EDITOR.

to put the above fittings back into place. Adjustment of connecting rod bearings almost impossible from below owing to lack of room to work in due to extreme depth of crank case and lack of room between sides of castelated nuts and bearing cap sides, even for a thin-sided socket wrench.

Lower end of cylinder not bevelled so that it is next to impossible to enter a piston from below.

Lubrication—Splash with forced circulation. Oil gauge most effectually hidden from sight and oil-receiving funnel so situated that nothing but a special flexible tube funnel can ever reach it and so small that it takes fifteen to twenty minutes to put in one-half gallon of oil of the viscosity prescribed by the manufacturer.

Oil circulation pipes so small that they are bound to plug up and placed so that removal is next to impossible.

Cooling—Radiator-filling hole so high above ground that a step ladder is necessary. Cooling pipes and hose connection hard to get at and so placed as to effectually bar the way to adjustment of other parts. Pump—so placed that the packing gland can leak for weeks before the operator plucks up courage enough to try to tighten it

with even a special wrench. The grease cups for pump shaft as inaccessible as the packing gland.

Ignition—Dixie magneto, impulse starter, plugs so located that to remove them just after the engine is stopped will necessitate the sacrifice of anywhere from one to six or eight square inches of skin owing to burns from the exhaust manifold. Also is necessary to always carry plenty of spare porcelain or plugs because their location is such that it is almost humanly impossible to put in or remove twenty plugs without breaking about five porcelain.

Governor—Own enclosed.

Carburetor—Own, but the fuel pipe from tank is so small that it will become partially choked under the slightest provocation and will not maintain enough pressure to keep the fuel in the float chamber at its proper level. It is very hard to remove so that it is seldom cleaned.

One might add in some cases that each of the different systems or units of the tractor is so connected with each of the others that it is impossible to get at some vital parts conveniently without removing all the rest. This would not be so bad if the proper faci-

lities for the removal of these parts were provided but in many cases it is a case of a sledge hammer to get shafts and tight nuts to budge. One can then expect a repair bill of considerable size owing to the destruction wrought in pulling down and repairing. All this is due, of course, to inaccessibility of the tractor's parts.

## Progress Being Made

It is true that considerable progress has been made in the way of removal of excessive weight in tractor construction. The proportion of drawbar power to each hundred pounds of weight has also increased during the last ten years. The perfecting of carburetors and the introduction of temperature regulators have made the burning of kerosene and other cheap fuels not only practicable but highly profitable. The introduction of the impulse starter on the magneto has reduced wiring to a minimum, has done away with the continual expense due to the necessity of battery current for starting and, best of all, it has reduced starting trouble to a minimum. All these the gas engine owner has to be thankful for, but we must remember that in spite of all these blessings all engines will need attention to their internal parts. Why must it be that there are engines on the market fully as bad as the above indicates? We happen to have these facts brought home to us in a most forceful manner by stern experience. No one can expect a machine of one thousand revolutions per minute to keep on running without attention for more than perhaps fifty to seventy-five days at a time. The strain tractors are subjected to when under load is terrific and most engines are doing nobly under it, but why discourage, yes even effectually prevent, proper attention by gross neglect of that quality—accessibility in the design of the machine.

The tractor of the future is the one designed in such a way that the parts which will need most frequent adjustment and more or less constant inspection and attention are most easily accessible.

## CLETRAC SERVICE MEN HOLD IMPORTANT MEETING

THE eleven district service supervisors of the Cleveland Tractor Company held a meeting at Cleveland, O., October 25th to 28th, under the direction of Geo. W. Pontau, Jr., service manager.

Bringing together the service problem of every section of this country and Canada they were able to formulate policies for next year which will be of great benefit to the Cletrac owner, the dealer and the manufacturer.

In discussing the results of their 1920 work it was determined that the company's aggressive educational policy had saved both the owner and the dealer a great deal of trouble and expense. The Cleveland Tractor Company is firmly convinced that free tractor service is an injustice to all concerned and its plan of educating the dealers' organization and the owner has gone a long way toward eliminating this menace to its dealers' profits.

## HANDLES BLUEBIRD ADVERTISING

SMITH, DENNE AND MOORE, LTD., Toronto, are handling the advertising account of the Bluebird Corporation, Brantford, Ontario, makers of "Bluebird" washing machines. The Bluebird Corporation has designed a trade-mark, the main lettering on which is "A Colonial-Made Appliance."

It is the intention of the corporation to make a wide variety of electrical household appliances which will be marketed under the above mentioned trade-mark.



Occurrences like the Wall St. explosion should help to arouse the public to the dangers of Bolshevism.



## 100% MEMBERSHIP

On Wednesday, Oct. 20, the Association of Canadian advertisers endorsed the statement of W. G. Stewart of Goodyear Tire and Rubber Company that all trade newspapers should be required to furnish audited statement of circulation.

We're with you, Mr. Stewart. Every publication issued by MacLean Publishing Company is a member of Audit Bureau of Circulations.

Advertisers who are members of A. C. A. and those who are not would be acting in their own interests and in the interests of Canadian publishers by insisting that every publication in which their advertisements appear should come out into the open and furnish a statement of circulation certified by some independent organization such as A. B. C.

The following MacLean publications will gladly send A. B. C. statement of circulation on request:

### TRADE NEWSPAPERS

HARDWARE AND METAL  
DRUGGISTS' WEEKLY  
CANADIAN GROCER  
SANITARY ENGINEER  
DRY GOODS REVIEW  
MEN'S WEAR REVIEW  
BOOKSELLER AND STATIONER  
CANADIAN MOTOR, TRACTOR AND  
IMPLEMENT TRADE JOURNAL

### MAGAZINES

MACLEAN'S MAGAZINE  
FARMERS' MAGAZINE

### TECHNICAL NEWSPAPERS

POWER HOUSE  
CANADIAN MACHINERY  
CANADIAN FOUNDRYMAN  
MARINE ENGINEERING  
PRINTER AND PUBLISHER

### COMMERCIAL NEWSPAPER

THE FINANCIAL POST

## BIRDSELL CLOVER HULLERS

Best for Threshing,  
Hulling and  
Cleaning

Little Red or Common Clover Seed  
Big English or Mammoth Clover Seed  
Alaïke Clover Seed  
Sweet Clover Seed



### THREE SIZES FOR CANADA

No. 2	Cylinders 27" x 32"	Capacity 3 to 5 bushels per hour,	Power Required 6 to 8 H. P.
No. 1	Cylinders 30" x 36"	Capacity 5 to 7 bushels per hour,	8 to 10 H. P.
No. 8	Cylinders 40" x 52"	Capacity 7 to 10 bushels per hour,	10 to 12 H. P.

WE HAVE A SIZE TO SUIT EVERY NEED

## ANN ARBOR HAY PRESSES

If in the market for a Hay Baler we can furnish in any size to meet your requirements. Write us or call and see us while in the city.

## Birdsell Manufacturing Co.

Foot of George Street  
Toronto, Canada

# Revolt Drain Excavator

*Sole Owners*

Land Drainage Excavator Co., Spalding, England

Labor-saving, Time-saving, Money-saving

Capacity:—The "Revolt" Excavator, drawn by TRACTOR, will complete a drain (3 ft. 6 in. deep), at the rate of 150 to 200 yards an hour. The "Revolt" Excavator, drawn by HORSES, will complete a drain (3 ft. 6 in. deep), at the rate of about 50 to 60 yards an hour.

The average cost of cutting drains with the "Revolt" Excavator is 25 cents per chain (66 ft.).

A Demonstration will be given in Excavating Drains on TORONTO MUNICIPAL FARM, Stop 45, Yonge Street, on FRIDAY, NOVEMBER 5th, between the hours of 2 and 4 p.m.

For full particulars apply to GEORGE C. BADDON, Box 482, Station F, Toronto



# Aikenhead's

"The Sign of Better Service"

## SIoux VALVE TOOL SET

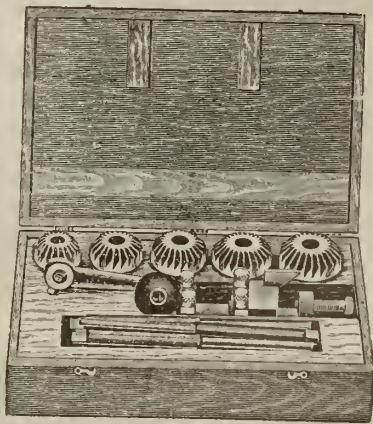

Sioux Valve Seat Reamers reface valve seats with the same dispatch, accuracy, smoothness and general satisfaction that the Sioux Valve Refacing Tool refaces the valves.

The Sioux Valve Tool Set includes the Sioux Valve Refacing Tool, and five Sioux Valve Seat Reamers:  $1\frac{3}{8}$  in.,  $1\frac{7}{8}$  in., 2 in.,  $2\frac{1}{8}$  in. and  $2\frac{1}{4}$  in., all 45-degree (30 and 60 degrees can be had on request), three pilot stems, 5-16 in.,  $\frac{3}{8}$  in. and 7-16 in.

The three pilot stems are finished to accurate size, insuring perfect dimensions and accuracy.

**Aikenhead Hardware Limited**

Toronto - Canada

# STEEL CASTINGS

for

# TRACTORS

CANADIAN  
STEEL FOUNDRIES  
LIMITED

General Sales Office:

Transportation Building  
Montreal

### J. F. MACKAY WITH MORROW COMPANY

J. F. MACKAY, formerly business manager of the Globe and latterly secretary and treasurer of the Willys-Overland, Ltd., has resigned his office with the latter company to become vice-president and general manager of the John Morrow Screw & Nut Co., Ltd., of Ingersoll. He will also occupy the position of vice-president of the allied industry, the Ingersoll File Co., Ltd.

This and other important changes are consequent upon the retirement of J. Anderson Coulter from the presidency of the two companies. Mr. Coulter has been actively connected with the progress of the industry for more than thirty years. The directors announce the election of Col. F. H. Deacon, of Toronto, as president; he has been vice-



J. F. MACKAY

president of the companies. The other appointments are: Assistant general manager and treasurer, H. P. Stone-man; sales manager, F. N. Norton; secretary, Lt.-Col. H. L. Edmonds.

### NEW ENGLISH TRACTOR

A NOVEL design of three-wheel tractor for agricultural and road building use has been designed by an English manufacturing company. In some respects the tractor follows late American practice inasmuch as it is the form that has no frame other than that provided by the engine base, gear box and extensions attached to the latter member to which the rear wheel is secured. Among the novel features of this tractor other than the adoption of the frameless system of design is the provision of power transmission mechanism to all three wheels. The two front wheels are combined directive and tractive members. The steering knuckles are exceptionally large and house in the universal joints by which the wheels are driven. The main drive from the change-speed gear case is by means of a double universally jointed shaft extending from the front end of the gear case to a differential housing on the front axle in which the main drive is by bevel gear reduction. The single rear wheel is operated by a shaft which carries a bevel pinion that engages the bevel gear on the wheel-supporting axle.

A power take-off is provided by which bevel gears transmit the power from the clutch shaft to a pulley at the side of the gear case to which a belt attachment can be made for driving any forms of machinery that would ordinarily be operated by belt power. The application of power to all three wheels of a light tractor is an attempt to secure maximum traction and the machine should have a greater effective draw-bar pull than any three-wheeled form of the same weight delivering the power only of one driving wheel, as is the usual construction when the three-wheel design is followed. The tractor shows clearly the influence of American practice; and the

method of dispensing with the frame by using the engine base for that purpose, the incorporation of a clutch and change-speed gearing as a unit with the engine and also as part of the frame structure, and the support of the fuel tank and installation of the radiator, are all very evidently copied from a well-known American tractor design that was produced in large quantities during the war in both this country and in England. The tractor illustrated is distinctive in design, however, in the method of power transmission.

### WANT CANADIAN EXHIBITS

THE following letter from the Bunnarfelag Islands was sent to Mr. Arni Eggertsson, of Winnipeg, the commercial representative of Iceland in Canada:

Dear Sir: As you know, the Icelandic Agricultural Society has in mind to hold an exhibition in Iceland next spring, where various agricultural implements and machines relating to farming will be on show. Obviously it is important for the society to get as many firms which manufacture such articles as possible to exhibit their goods.

We would therefore kindly ask you whether you would inquire of the Canadian Government and various factories in Canada which manufacture agricultural implements whether they would be agreeable to send some specimens of such articles to place on this proposed exhibition. For your guidance we beg to point out some articles and machines which are still but little known in this country, and may be expected to become valuable for the Icelandic farming if they were imported and made use of and eventually suited for Icelandic conditions, if they could not be directly applied.

We believe that our countrymen in America would be able to see what articles would be best for us.

We beg to enclose herewith a list of the principal articles and implements which will be on exhibition, and should be very glad to hear from you shortly regarding this matter, and remain,

Yours truly,

(Signed) S. Sigindsdan.  
M. Stefansson.

The following is the list of machines and implements mentioned in the letter:—Tractors, plows, harrows, ditching machines, etc., to be used in connection with tractors.

Horse-drawn implements — Plows, harrows, rollers, manure spreaders, drills (for grain, turnips and potatoes), hoes, potato diggers, etc., of different kinds.

Hand tools—Spades, shovels, forks, crowbars, wheelbarrows.

Gardening implements — Seeders, rollers, hoes, lawn mowers, rakes, greenhouse implements.

Horse-drawn mowers, rakes, tedders, stackers, etc.

Hand implements—Sharpening tools, hay forks, etc.

Other implements — Hay thermometers, hay-drying machines, hay presses, haylifts, etc.

Dairy tools, domestic tools, stable tools, electrical instruments for domestic use, including lighting, heating and boiling instruments.

Water pumps, pipes, hydraulic rams, peat tools, stone quarry tools, blacksmith outfit tools, woodwork tools, etc.

One of Sir Thomas Lipton's favorite stories concerns an old Scotchman, who went to a horse race for the first time and was induced to stake a sixpence in the third race on a forty-to-one shot. By some miracle this horse won, and when the bookmaker handed the old man his winnings he could hardly believe his eyes.

"Dae ye mean to tell me I get all this for ma sixpence?" he exclaimed.

"You do," replied the bookmaker.

"Ma conscience," muttered the Scotchman. "Tell me, mon, how long has this thing been goin' on?"—Boston Transcript.



**MAYBE ADAM  
LAUGHED  
AT THESE**

"I hear you had a blow-out at your house last night."  
"No, that was just a report."—Notre Dame Juggler.

"This fish which you have reduced in price is, I suppose, good for immediate cooking?"

"Yes, but run home!"—*Fliegende Blatter* (Munich).

A certain young lady named Snyder Ran a still—When the officers spied 'er,

They asked what she did  
With the stuff—where 'twas hid?  
She replied that she put it in cider.—*Auto Links*.

William and Henry, chauffeurs, were discussing the ill luck of a fellow chauffeur, Clarence, who had the day before been fined for taking out his employer's car without permission.

"But how did the boss know Clarence had taken the car out?" asked Henry.

"Why," explained William, "Clarence ran over him."—Harper's.

The eloquent young theologian pictured in glowing words the selfishness of men who spent their evenings at the club, leaving their wives in loneliness at home.

"Think, my hearers," said he, "of a poor, neglected wife, all alone in the great, dreary house, rocking the cradle of her sleeping babe with one foot and wiping away her tears with the other."—*Plowman Dealer*.

"Nigger," warned one, "don't mess wid me, 'kase when yo' do, yo' shuah is flirting wid de hearse." "Don't peticate me, nigger," replied the other, shaking his fist. "Don't fo'ce me to press this upon yo', 'kase if I does, I'll hit yo' so hard I'll separate yo' from amazin' grace to a floatin' opportunity." "If yo' mess wid me, nigger," cried the first, showing the whites of his eyes, "I'll jes' make one pass, and dere'll be a man pattin' yo' in de face wid a spade to-morrow mornin'."

An Irish lecturer, expatiating on the nature of man, remarked that one point of distinction between human beings and lower animals consisted in man's capacity for progress.

"Man," exclaimed the lecturer, "is a progressive being, other creatures are stationary. Take, for example, the ass. Always and everywhere it is the same creature. You never have seen, and never will see, a more perfect ass than you see at the present moment."

Several persons were making purchases in the hardware shop on a very stormy day when an old man with a stick in one hand and a bundle in the other entered and asked:

"Did any of you drive up here in a cart?"

"Yes, I did," replied one man.

"Was it an old white hoss?"

"Yes."

"And an old woman on the seat?"

"Quite right."

"And can she manage that hoss?"

"I should think she can."

"Then it's all right," said the man of the stick and bundle. "The old hoss has run away, and the old woman is hanging on to the tailboard, shouting 'Murder' with all her might; but if she can manage it there's no use of anybody getting excited over it. I want ten cents' worth o' shingle nails."—*Good Hardware*.

# Northern Electric POWER and LIGHT

## A Complete Line of Electric Farm Plants and Accessories

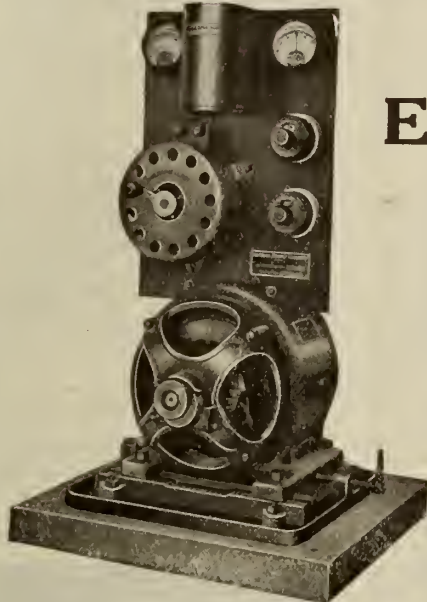

Belt-Connected Plant—operates from any good engine

- Belt-Connected Plants
- Direct-Connected Plants
- Water Systems
- Portable Motors
- Farm Accessories
- Wires and Supplies

This line will make you the Electrical Headquarters of your District.

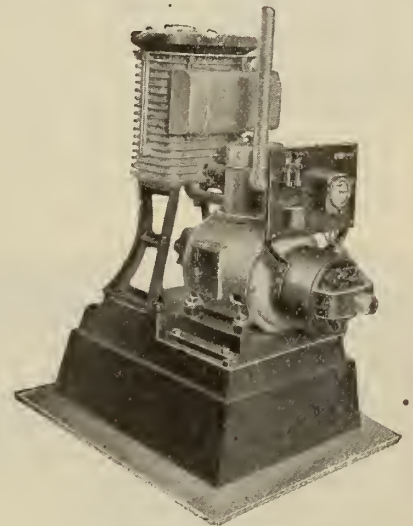

Direct-Connected Utility Plant  
¾ K.W.—32 Volt



Automatic Water System, showing Tank, Pump and Motor.  
Capacities 100 to 1,400 gals. per hour

With the plant you can usually sell a Water System, while limitless follow-up sales possibilities are yours with Utility Motors, Electric Churns, Vacuum Cleaners, Washing Machines, Dishwashers, Irons, Toasters, Percolators, Wiring Devices of all kinds, Fixtures, etc.

Write Our Nearest House Now

Be the Farm Electrifier of Your District

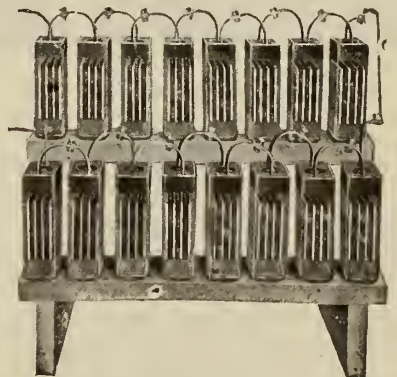

Titan Storage Battery, 16 cells supplied with each plant. 110 or 200 Ampere Hours.

## Northern Electric Company LIMITED

MONTREAL    OTTAWA    LONDON    WINNIPEG    EDMONTON    VANCOUVER  
HALIFAX    TORONTO    QUEBEC    REGINA    CALGARY

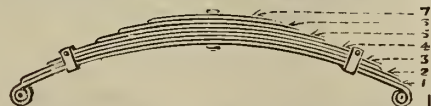

## AUTOMOBILE SPRINGS

The Guelph Spring and Axle Co.

Guelph - Ontario  
Manufacture

AUTO SPRINGS  
ALL KINDS  
HIGHEST QUALITY

## Keeping Tab on Conditions

During the unsettled conditions of to-day it is necessary to watch the markets and the trade news very carefully.

An order for Press Clippings will bring to your desk each day the particular news you want, culled from the newspapers of Canada. You are kept posted right up to the minute and there is no better time than the present to make use of our service.

SUBSCRIBE TO-DAY

Canadian Press Clipping Service

143-153 University Ave., Toronto



# Service—Or Service Plus

From "The Portager"

"SERVICE, yes, I've heard that word before—sometimes spelled with a capital 'S' and at other times in all caps. It's the keystone of my business—something we all need, cry for, shout for, die for! They tell me—manufacturers, trade papers, salesmen—service means satisfied customers, more money in my pocket and that it is my best advertisement. That's fine. All true I suppose—but won't somebody please tell me what service really is, what it consists of? Not a definition—I know all the definitions backwards, forwards, and upside down—but something concrete and definite about it—how can I give service? Those are the things I want to know."

So says a dealer. And probably many others think the same but have never expressed themselves in this manner. To try to tell all there is to be told of service is a mighty task—and if every retailer in the country could get in touch with every other retailer and swap experiences and ideas, only then would we begin to get a correct expression of the true meaning and method of application of service.

## Service An Old Word

It is not a new word—it's as old as the hills. For many years we have received and given service of one kind or another without a realization of the fact being forcibly impressed upon us. Either we are doing something for others or others are doing something for us.

Let us put it this way, as regards retail business—service consists of all the attentions you show a customer from the minute he enters your shop until he leaves—and even after he leaves until there is absolutely nothing further to be done in connection with the article bought. In consists of a number of things as good value, honesty, fair dealing, alertness, courtesy and sincerity.

To do the unexpected—that is true service.

Advertising gives an article the desired publicity and creates the demand while salesmanship sells the article—but it takes service to seal that bargain and keep the article sold. It is the key to a whole industry and is the backbone of the future of a concern, by virtue of the fact that nearly all repeat orders are a result of service rendered.

All right, what does service consist of? Well, good value is one thing which helps to make service. If an article is priced twice what it is worth, the amount of service per unit paid is very small. If priced at half its actual value the amount of service will be great compared to the price. It need not follow that only articles low in price will give the best service—for an article of good construction fairly priced will naturally give the best service. This is one interpretation, in a strictly utilitarian sense, of service.

## Honesty and Fair Dealing

Honesty and fair dealing—does it seem necessary to say that these are essential requisites of service?—honesty and fair dealing in purpose and in price. These are two features on which all business is build—a solid foundation which is sure to pay by its ability to prevent foundering or settling. Fair dealing is the fruit of a clean business conscience and is the result of adherence to the old principle of "live and let live." See that the products you sell are honest in quality and in price. It is just as easy to make a profit out of honest goods sold by honest methods as it is to sell trash dishonestly. And besides it is better for your conscience, for honesty wins the esteem of others and not only creates admiration and support but creates faith in one's self.

Alertness covers several phases of

your business—and the lack of it implies unsound practice in one case and downright lack of courtesy in the other. Alertness requires constant attention to the details of your market—general and specific conditions which tend to govern prices and in turn set the prices for the articles you must purchase. Taking advantage of the chance to obtain goods at a fair price is an opportunity not to be overlooked in the interests of your customers for opportunity might best be placed on a tombstone unless you put some life in it!

## Alertness Makes Customers

Alertness of the other sort is much easier to practice and comes more naturally to most people. It is a reflection of one's mental process in their relation to his business. Do you consider your business big or interest-absorbing enough so that you continually desire to better it? How do you attempt to put this into effect? Steady repeat customers are probably among the best builders for the future which a retail business can have—and one of the surest ways of changing a once-in-a-while customer into a steady customer is to be alert—to give him your individual attention so that you always can give him the best there is in you—in service, ability, knowledge and time.

When a customer enters your shop, become alert. He is your guest and should be treated as such. Show him every courtesy possible and do not be slow in coming forward or greeting him. Show him by your actions that you are mentally as well as physically alert and try to anticipate his needs as best you can. Give him your individual attention and do not try to rush him nor try to force a sale, for alertness consists not in consummating a deal in the shortest time possible, but in completing the transaction in the least time consistent with adequate service.

## Sincerity is Essential

Sincerity in purpose and in promise should be the cornerstone of your business. Be sincere in every statement you make—if you say you are glad to see Mr. Brown again, be sincere or say nothing at all. The chances are that Brown will see through you anyway if he has any reason to believe you are not sincere. A promise made should be a promise fulfilled. When you come out of your office to greet Jones whom you had promised something at that particular moment, don't forget to leave your excuses in your office. Jones is not interested in them and doesn't give a whoop to hear them. Keep promises and if you find this difficult, don't make them. A broken promise is usually the cause of a loss of faith in yourself and shop, and lack of faith on the part of your clientele eventually means locking up your front door and throwing the key away.

It has been said that service is a good sales argument and is a creator of satisfied customers. Satisfied customers are boosters—and a booster carries more weight with many people than all the signboards, printed advertisements or boast in the world. That is the result of true service!

## REGO CUTTING APPARATUS

WE have received a very fine catalogue dealing with Rego welding and cutting apparatus which will be of interest to the repairman. The Carter Welding Co., Toronto, Canada, are sole sales representatives for this line, and to those not familiar with this apparatus we suggest a perusal of the following:

The Rego principle of gas mixture, whereby the acetylene enters the mix-

ing chamber at a slightly higher pressure than the oxygen, is said to positively insure the elimination of the flash-back under all operating conditions. It is claimed that it materially reduces the oxygen pressure, thereby preventing any excess and wasteful oxygen, which is detrimental to good welding. Economy of operation, safety and perfection of flame, are other features claimed for this line.

The catalogue shows some actual photographs of tests for flashbacks, and it is clearly shown that there is no flashback occurs. The book deals with the carrying-cases, trucks and various welding apparatus. There are also shown some welding and battery outfits, some lead burning and light welding apparatus and a decarbonizing outfit.

Another item is a description of the Rego torch, with complete data on the same. The various models are shown, and specifications given. The latter part of the book describes tripod manifolds, wall manifolds and the Rego diaphragm regulator together with detailed description. Other styles of regulator are shown, also adapters, hose connections, wrenches, etc., etc.

## WINS THE SILVER CUP

HEARTIEST congratulations are due to Mr. G. S. Gordon on his success on winning the Silver Cup awarded by the Head Office of Beatty Bros. Limit-



G. S. GORDON

ed, Fergus, Ont., to the salesman selling the highest volume of stable equipment during the firm's business year.

This cup has now been awarded for two years, being won in both cases by a salesman under direction of the Montreal branch. Last year's winner was H. P. Renaud. The trophy becomes the property of the salesman winning it three years in succession.

Mr. Gordon is a veteran, and was seriously wounded in the war. His success in coming out on top of a list of 36 men is certainly remarkable as he has only been "on the road" for Beatty Bros. a comparatively short time.

## SELL AUTOMATIC WATER BOWLS

DEALERS who sell dairy equipment will find the selling of water bowls a means of increasing winter business. Milk contains 87 per cent. of water. It is unlawful and morally wrong for man to add water to the milk which he sells, but the cow can put in the legitimate amount without violating the law or incurring the ill-will of society. Therefore, the profits to be derived from the dairy business depend directly upon furnishing the herd an abundant supply of water and in such a manner as to produce a maximum flow of milk. Cows should be

able to get water at such times as suit their pleasure. In cold weather a chill should be taken off the drinking water. One of the most efficient means of meeting these difficulties is to water the cows in the barn with the automatic water bowl. In many places milk is now worth 4 cents per pound. If by watering twenty cows in the barn the milk flow should be increased two pounds per day for each cow, this would mean \$1.60 per day in revenue which would yield handsome returns on the investment.

## NEW ENFIELD ALL-DAY MODEL

ENFIELD ALL-DAY MOTORS LTD., Small Heath, Birmingham, England, will exhibit at Olympia, Stand No. 63, their new model 10 h.p. Light Car De Luxe. This model has been produced to meet the existing demand for a medium powered touring car, reasonable in price and with a low taxation rating. The engine is of the 4-cylinder water cooled type, the cylinders being cast en bloc. Bore 63.5, stroke 117.5 m/m. R. A. C. rating 10 h.p. The valves are inclined with adjustable tappets and the balanced crankshaft and cam-shaft are carried on three bearings. Lubrication is by pump through oil ways cut in the shaft. The gear box, which is a separate unit, provides three forward speeds and a reverse, and the final drive is by spiral bevels. The suspension is by semi-elliptic springs in front and full cantilever springs at the rear. The show exhibit will consist of a polished chassis and two complete cars, one a two-seater and the other a four-seater. The equipment includes detachable steel wheels, spare wheel and tire, hood and screen, Brolt dynamo electric lighting and starting sets, horn and tools. This chassis, while following recognized practice, is right up-to-date in all details of design and of the very highest quality of materials and workmanship throughout.

## SPRING WILL SEE CREDIT IMPROVE

DISCUSSING the outlook for the automotive industry, Ralph Van Vechten, vice-president of the Continental & Commercial Bank, which has undertaken a large share of the financing of the Goodyear Tire & Rubber Co., said:

"The automobile industry must wait until general liquidation reaches a point where the credit situation is relieved, which probably will take most of the winter. I wouldn't be surprised to see some improvement in the early spring and once it starts there should be rapid recovery, culminating in a considerable rush all around and greater prosperity than the automobile industry ever had. Large manufacturers realize banking necessities and are co-operating."

## GEORGE M. REID IN HOSPITAL

ACCORDING to a Canadian Press despatch George M. Reid, ex-president of the London, Ontario, Motor League is in Roosevelt Hospital, New York, suffering from concussion of the brain and a possible fracture of the skull, received on the night of Nov. 4 when he was struck at Sixth Avenue and 43rd Street by an automobile. Mr. Reid was a guest at the Hotel Pennsylvania, New York.

"For rent — Furnished room for gentleman looking both ways and well ventilated."

Tommy had an accident while fishing and had fallen into the pond. Just as he was scrambling out an old lady came along. "Dear, dear me!" she said fussily, "how did you come to fall in the pond?"

"I didn't come to fall into the pond," said Tommy. "I came to fish."—Pearson's Weekly.



**IMPROVED SPIRAL CHUCKS**

THE Charles Taylor Co., Ltd., of Birmingham, England, have placed on the market their patent improved spiral chucks. These chucks are being handled in Canada by Messrs. Williams & Wilson, 84 Inspector St., Montreal, and they are exclusive agents for the same.

These chucks, of which we show a line drawing herewith, embody many interesting and important features of design that add greatly to their efficiency and durability under

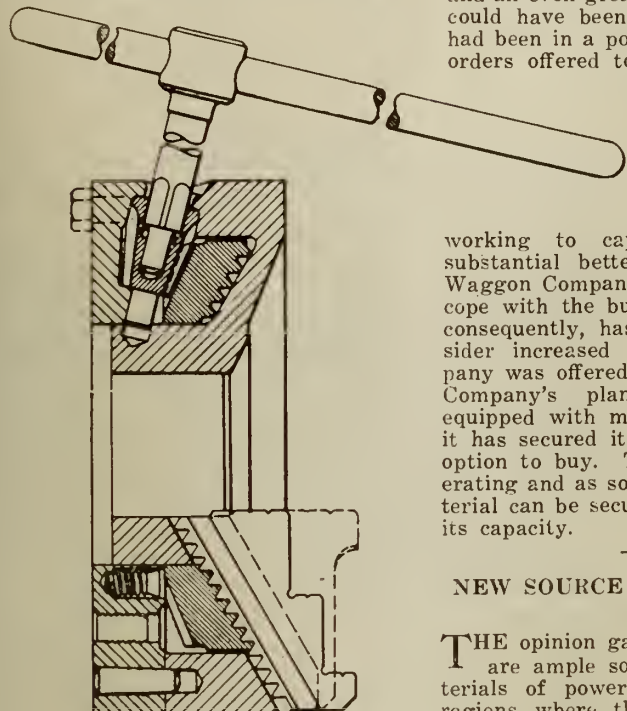

Line Drawing of Chuck

continual and exacting service, and are the recent outcome of 35 years of manufacture and study of self-centring chuck requirements.

The construction of the chuck is such that the movement of the jaws is not at right angles to the lathe spindle, but inclines inwards at an angle of about 30 degrees. This design permits of a thrust upon the spiral rack and more directly back of the jaws, thus minimizing the tendency to tilt that is said to be always present in chuck jaws where the movement of the jaws is square with chuck axis. The V shape of the rack permits of a finer pitch, giving greater gripping power and the inclined position provides for a better distribution of the pressure, as the bulk of this is transmitted through the solid metal of the jaws and square with the axial line of the rack.

The pinion for operating the spiral rack is non-protecting and the bearing surfaces of all the moving parts are hardened and ground. This adds very greatly to the life of the chuck. Special provision is made for taking up any slight wear of the moving parts. Every part of these chucks is made to limit gauges and is interchangeable and every chuck is guaranteed to grip true to within .002 measured 3 inches from face of jaws. They are claimed to be the tightest gripping self-centring chucks made.

The strength of the parts of this improved chuck permits of a length of key handle approximately twice that of ordinary chucks, giving corresponding greater grip and providing this extra grip by leverage that loses nothing in extra friction. In addition to the usual 3-step and bar jaws, "soft" blank jaws are supplied. These blank jaws are hardened on the teeth to withstand wear, but are left soft on front face and grip, so they can be machined to hold any special or odd shaped article.

**HIGHER PROFITS BY COCKSHUTT**

AN increase in net profits to \$660,921 from \$571,586, and a substantially improved position in other directions, is shown by the annual report of the

Cockshutt Plow Company, Limited, just made public. Dividends amounting to 7 1-2 per cent. on preferred were paid, as against 4 per cent. in the previous year, and the balance at credit of profit and loss was \$576,434, as against \$399,387. Loans were reduced from \$594,767 to \$124,924. Earnings on preferred were at the rate of 10.23 per cent., as compared with 8.84 in the previous year. According to President H. Cockshutt there has been a large and well-sustained demand for the company's product during the year, and an even greater volume of business could have been done if the company had been in a position to accept all the orders offered to it.

The subsidiary companies, Adams Waggon Company, and Brantford Carriage Company, have had a very successful year, working to capacity, and showing substantial betterment. The Adams Waggon Company has not been able to cope with the business offered it and, consequently, has been forced to consider increased facilities. This company was offered the Petrolea Waggon Company's plant at Petrolea, fully equipped with modern machinery, and it has secured it under lease, with an option to buy. This plant is now operating and as soon as a supply of material can be secured will be worked to its capacity.

**NEW SOURCE OF POWER ALCOHOL**

THE opinion gathers force that there are ample sources of the raw materials of power alcohol available in regions where the difficulties in connection with the transport of plant and machinery required and of the product to the consuming centres are not so great as in some of the areas which have been marked out as ideal raw material producers.

It is reported that in the Pacific islands alone, maize, cassava and sugar cane could be grown and utilized to an extent which should produce 50,000,000 gallons a year, and it is suggested that the world demands could be filled by the raw material available within certain Empire areas. Estimates of the cost of obtaining industrial alcohol from the crops named indicate that 6d. per gallon is a figure which could be realized and the process of distillation should be associated with the recovery of valuable by-products. Even when the cost of overseas transport is added to the production cost, it is assumed that the fuel could be placed on the home market at prices which would compare favorably with the cost of gasoline.

**RUSSELL MAKES GOOD SHOWING**

THE Russell Motor Car Co., Limited, Toronto, has just issued its annual statement which makes a creditable showing in view of the process of reorganization which the company has been passing through during the last year. Net profits after providing for taxes, depreciation, etc., are understood to be approximately \$300,000. This compares with \$457,878 a year ago and \$621,581 in the 1917-18 period.

**OPENS NEW BRANCH**

J. A. GREENHILL, manager of the Pacific Tractor Company, of Vancouver, has been in Penticton, British Columbia, during the past few days opening up a branch warehouse there in the premises on Lake Shore Drive, formerly occupied by the B. C. Growers, and more recently by the Hardesty Metal Flume Company. Mr. Greenhill announces that a line of tractors will be carried and the warehouse will also be stocked with drag saws and agricultural implements of all kinds. No local manager has yet been appointed. The local branch is to be thoroughly equipped for business in the spring. An office and sales department will be carried on, however, during the winter.

**LEGALITE LENS**

*Accepted by Department of Public Highways*

**THE LEGAL-LIGHT**

THE DEPARTMENT of Public Highways have recently announced that Legalite Lenses

have passed the required test and are accepted as complying with the Anti-Glare law passed last session of Provincial Parliament. Legalite lens are there-

fore the legal and logical lens for the Motorist.

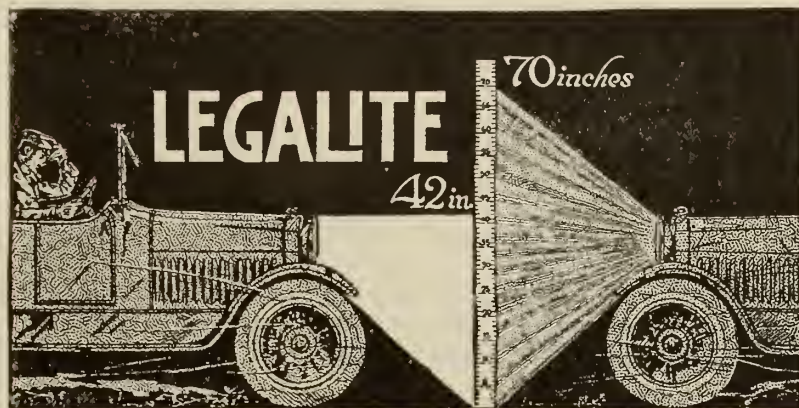
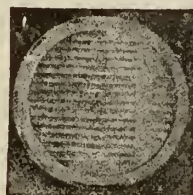

**Comply With the Law—More Light—No Glare**

With Legalite lens the motorist takes no chances of being apprehended by the law. It is legal and has received the endorsement of every Province in Canada and every State of the U.S.A.

They are scientifically constructed so that the light beams are never more than 42 inches above the ground at any distance from the car, as required by the law. You get the light where you need it—on the ground, even when going up hill.

**Dealers' Opportunity**

The announcement of Legalite lens passing the test of Dept. of Highways will surely create a big demand for Legalites. Be in a position to supply the demand for the 150,000 passenger cars, commercial vehicles and trucks in Ontario which will be obliged to equip with a suitable non-glare device. Get your supply at once.

Prices, Per Pair:		Prices, Per Pair:	
8 " to 8 5/8"	\$4.25	For Fords, Chevrolet	
8 3/4" to 9 5/8"	5.25	490 and new Overland 4	
9 3/4" to 11 1/2"	6.75	8 1/2"	\$3.25

**HYSLOP BROTHERS LIMITED**

Shuter and Victoria Streets  
TORONTO, ONTARIO



Little Visits **Beatty Bros. Limited** With BT Dealers **Bulletin**



**A BT Agent for Sixteen Years**

*Hampden June 5 1920*  
 Beatty Bros  
 Dear Sir  
 I must say it has been a great pleasure to me in the sixteen years I have been engaged in selling B T goods to the public to watch the marked improvement from year to year in building up the world-famous name which you now have and all lines of goods which you now manufacture and the strong belief that you have on the part of the public to trust the B T manufacturing of James Souch and the Beatty Bros and not to doubt and a safe company and most reliable in the past pleasure in consulting Beatty Bros in the great success they have achieved in the 16 years I have been their agent.  
 Yours truly  
 C. W. Souch

Mr. C. W. Souch of Hampden, Ont., started to handle BT goods in the year the BT Manure Carrier was invented—1904.

For sixteen years he has been selling BT Barn Equipment, also pumping outfits and other BT goods. Sixteen years is a long time. Mr. Souch has seen

us grow from a small concern to a large one and we take this opportunity of paying tribute to the splendid work of men like Mr. Souch. Their energy and splendid local reputations are largely responsible for the success of Beatty Bros., Limited.

**The BT Manure Carrier**

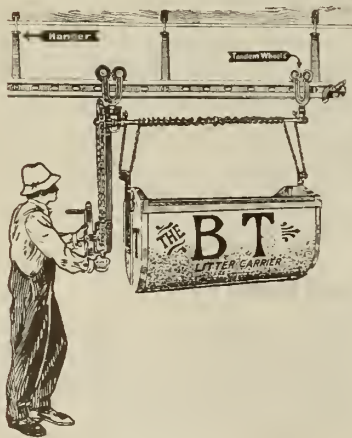

There is no better article from a dealer's standpoint than the BT Manure Carrier.

In the first place — it stands up and gives satisfaction. It is sold during the Winter and late Fall when there is little doing in the general implement business. There are no second-hand machines to bother with.

There is a splendid margin of profit. The BT Dealer is backed by heavy advertising campaigns in farm

papers and given every possible help in selling.

The Manure Carrier is now a necessity and farmers will be putting them in on **your** territory this Fall and Winter. Write our nearest branch and get particulars of our agency contract if it is not yours already. If it is, push Manure Carriers this Fall and Winter. You could not possibly spend the time more profitably.

**BEATTY BROS., Limited**

Fergus, Ont. St. John, N.B. Winnipeg, Man.  
 London, Ont. Montreal, Que. Edmonton, Alta.  
 Vancouver, B.C. London, Eng.

**"THE BT AGENCY PAYS"**

**Dairy and Household Supplies**

**UNIVERSAL ELECTRIC WASHER**

**T**HE Universal electric clothes washer is a portable washer, simple and efficient in operation. It can be used in the tub provided with the unit or instantly adjusted in any standard basement laundry tub. There are no belts, chains or sprockets to break or get out of order.

The makers claim that every single piece of material used in construction is of metal that will not rust. The cylinder is made of zinc with galvanized steel ends and revolves one way. It will run on any kind of current used in the home. Clothes can, if desired, be washed, boiled and sterilized at the same time, the makers say, by placing the washer on basement gas plate or kitchen gas range. It washes, rinses and blues clothes entirely without handling or removing them from cylinder.

There is an adjustable extension arm which makes the washer adaptable to all standard sizes of stationary tubs. The makers claim that the continuous one-way motion does away with all shocks and jars common to machines with reversible cylinders. The motor is sturdy and requires very little attention. A governor automatically controls the speed. The motor will operate from any 32-volt private farm lighting plant.

In operation the Universal washing cylinder is placed in position in the stationary laundry tub or the Standard Universal tub as conditions warrant. As the cylinder revolves one way, the paddles lift the clothes up until they drop back of their own weight. Each time the clothes fall, the steaming hot soap suds are also flushed through the cylinder perforators at both ends and from all sides, and on through the meshes of the clothes. The Universal, owing to its compact, portable construction and light weight, occupies no more space in the home than a small trunk. It is manufactured by the Universal Utilities Corporation, Alpena, Michigan.

**A NEW DAIRY DISCOVERY**

**SANITATION**, in connection with the production and handling of food and drink products, to prevent the spread of disease germs, has become a most important question. This is shown by increasing number of rules, regulations, ordinances, and inspections calling for cleanliness and scrupulous sterilization.

A marked advance in chemical sterilization has recently been made through the discovery, by Dr. H. D. Dakin, of a definite, synthetic substance, scientifically known as para-toluene-sodium - sulphochloramide, and commonly known as the "chloramines." Doctor Dakin was sent to France under the auspices of the Rockefeller Institute, to collaborate with the famous French surgeon, Dr. Alexis Carrel, in developing a new germicide for use

in war hospitals. The first step resulted in the well-known Dakin, or hypochlorite solution. Doctor Dakin, eager to improve his first solution, continued his investigations and discovered the "chloramines," which are far more permanent in character and less irritating than the hypochlorite solutions. Following this important discovery Dakin adapted the idea to the development of a water sterilization tablet, composed of one of the chloramines in a slightly different form. This substance, named by Doctor Dakin, halazone, has been extensively used by the Red Cross to purify polluted drinking water, in all parts of the world.

It has now been found possible to combine these various chloramine bodies with an alkaline salt to produce a powerful, non-poisonous powder, known as sterilac, for disinfecting and deodorizing milking machines, dairy utensils, and all apparatus where food and drink products are handled. Laboratory tests show that this disinfectant is forty-five times stronger in its power to kill bacteria than pure carbolic acid. It does in a few minutes what it takes corrosive sublimate hours to do and it is harmless and safe. One-sixth of an ounce to thirty gallons is sufficient to purify contaminated drinking water for the live stock and the home.

Successful experiments have also been conducted in various agricultural stations. These experiments by Professor Prucha, and others, made with chemically pure chloramines, were conducted under exactly the same practical conditions that exist on the farm and in the dairy. These tests proved that the action of the chloramines is prolonged, effective in hot or cold weather, and that this substance, in the strength recommended, does not attack rubber nor metal. Hence it should be of value to the dairyman in keeping his cream separators, milking machines and utensils clean.

**NEW EMPIRE MILKER SIGN**

**T**HE Empire Milking Machine Company is distributing among its dealers a new steel milker users' sign. The sign is attractively laid out, printed in blue and cream and made of a high grade steel.



Universal Electric Washer.



# LEADERSHIP OBLIGES

The De Laval Company active  
in dairy educational work

A reason why the De Laval  
contract is a valuable asset

For a number of years The De Laval Company has carried on a very important work for the upbuilding of the dairy business and of dairy communities.

It has conducted this development work along lines similar to the extension work done by many agricultural colleges and by the Government. Well-known authorities have been employed by the De Laval Company and they have devoted their time to dairy development work. Their efforts in this work have contributed a great deal to the promotion of better dairying. These men are giving lectures and talks to farmers on the best dairy practice, as well as counsel and advice on the buying, feeding and handling of cows.

Besides this personal work thousands of letters are answered yearly, and booklets and bulletins are distributed throughout the country, all with the object of advancing the dairy industry.

The services of the De Laval Dairy Development Department are free, not only to all De Laval users and agents, but to anybody interested in promoting better dairying.

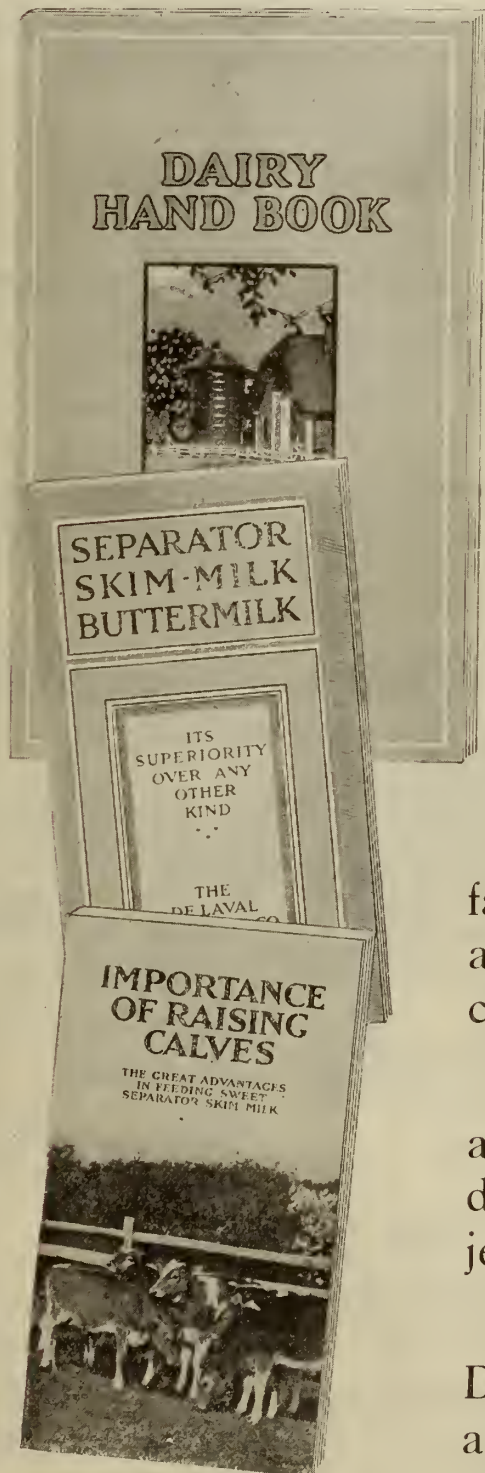

**THE DE LAVAL COMPANY, Limited**

MONTREAL

PETERBORO

WINNIPEG

EDMONTON

VANCOUVER

*50,000 Branches and Local Agencies the World Over*



# CANADIAN Motor Tractor and Implement Trade Journal BUYERS DIRECTORY

This directory will help you with your buying and your planning. The advertisers listed here are thoroughly reliable and leaders in their respective fields. They are looking for live, wide-awake representatives. Study their advertisements carefully because they contain valuable information which will dovetail with your plans. We are glad to go to the trouble of arranging this list—to make it easy for you to select new lines. If it so happens that what you want is not here, write us, and we will tell you where to get it.

**ACCESSORIES**

Canadian General Electric Co., Toronto.  
Canadian Car & Foundry Co., Montreal, Que.  
Champion Spark Plug Co., Windsor, Ont.  
Guelph Spring & Axle Co., Guelph.  
Northern Electric Co., Ltd., Montreal.  
Apollo Plug Mfg. Co., Birmingham, Eng.  
R. F. Sedgley, Inc., Philadelphia, Pa.  
McCord Mfg. Co., Walkerville, Ont.  
Kinzing Bruce Co., Niagara Falls, O.  
Aikenhead Hardware Co., Toronto.  
Hyslop Bros., Toronto.  
Lamontagne, Ltd., Montreal.  
Perfex Radiator Co., Racine, Wis.

**AUTOMOBILE BUMPERS**

Kinzing Bruce & Co., Ltd., Niagara Falls, Ont.

**AUTOMOBILE CHAINS**

Hyslop Bros., Toronto.

**AUTOMOBILE JACKS**

Kinzing Bruce & Co., Ltd., Niagara Falls, Ont.

**AUTOMOBILE MIRRORS**

Hyslop Bros., Toronto.

**BARN EQUIPMENT****BEAN MACHINERY**

John Deere Mfg. Co., Welland, Ont.

**BEEF MACHINERY**

International Harvester Co., of Can., Ltd., Hamilton, Ont.  
John Deere Mfg. Co., Welland, Ont.

**BEARINGS****BINDERS**

The Frost & Wood Co., Ltd., Smiths Falls, Ont.  
International Harvester Co., of Can., Ltd., Hamilton, Ont.

**BELTING****BREAK LINING****BATTERIES****CARRIAGES**

Cockshutt Plow Co., Brantford, Ont.

**CREAM SEPARATORS**

De Laval Co., Ltd., Peterboro, Ont.  
International Harvester Co., of Can., Ltd., Hamilton, Ont.  
R. A. Lister Co. (Canada), Ltd., Toronto

**CEMENT MIXERS****CASTINGS**

Joliette Castings & Forgings Ltd., Montreal and Joliette, Que.

**CORN HARVESTERS**

Cockshutt Plow Co., Brantford, Ont.  
International Harvester Co., of Can., Ltd., Hamilton, Ont.

**CORN MACHINERY**

International Harvester Co., of Can., Ltd., Hamilton, Ont.  
John Deere Mfg. Co., Welland, Ont.

**CULTIVATORS**

Cockshutt Plow Co., Brantford, Ont.  
John Deere Mfg. Co., Welland, Ont.  
Massey-Harris Co., Toronto.  
The Frost & Wood Co., Ltd., Smiths Falls, Ont.  
International Harvester Co., of Can., Ltd., Hamilton, Ont.

**CUTTERS**

Butterfield & Co., Inc., Rock Island, Q.

**DAIRY SUPPLIES**

International Harvester Co., of Can., Ltd., Hamilton, Ont.  
R. A. Lister Co. (Canada), Ltd., Toronto  
DeLaval Dairy Supply Co., Peterboro.

**DIES**

Butterfield & Co., Inc., Rock Island, Q.

**DISCS****DITCHING MACHINES****DRAIN EXCAVATORS**

George C. Baddon, Box 482 Station F, Toronto.

**DRILLS, TWIST**

Butterfield & Co., Inc., Rock Island, Q.

**DRILLS, GRAIN**

Cockshutt Plow Co., Brantford, Ont.  
International Harvester Co., of Can., Ltd., Hamilton, Ont.  
John Deere Mfg. Co., Welland, Ont.  
The Frost & Wood Co., Ltd., Smiths Falls, Ont.

**ELECTRICAL EQUIPMENT**

Can. General Electric Co., Ltd., Toronto.  
Northern Electric Co., Ltd., Montreal.

**ENGINES**

Gilson Mfg. Co., Ltd., Guelph, Ont.  
International Harvester Co., of Can., Ltd., Hamilton, Ont.  
John Deere Mfg. Co., Welland, Ont.  
The Frost & Wood Co., Ltd., Smiths Falls, Ont.  
R. A. Lister Co. (Canada), Ltd., Toronto  
The Turner Mfg. Co., Port Washington, Wis.

**ENSILAGE CUTTERS**

Gilson Mfg. Co., Guelph, Ont.  
International Harvester Co., of Can., Ltd., Hamilton, Ont.

**EXCAVATORS**

George C. Baddon, Box 482 Station F, Toronto.

**FEEDERS**

John Deere Mfg. Co., Welland, Ont.

**FARM MACHINERY**

Cockshutt Plow Co., Brantford, Ont.  
John Deere Mfg. Co., Welland, Ont.  
International Harvester Co., of Can., Ltd., Hamilton, Ont.  
The Frost & Wood Co., Ltd., Smiths Falls, Ont.  
R. A. Lister Co. (Canada), Ltd., Toronto  
Gilson Engine Co., Guelph, Ont.

**FEED CUTTERS**

Gilson Engine Co., Guelph, Ont.

**GREASE CUPS****GRINDSTONES**

S. Vessot & Co., Joliette, P.Q.

**GRINDERS**

International Harvester Co., of Can., Ltd., Hamilton, Ont.  
R. A. Lister Co. (Canada), Ltd., Toronto  
S. Vessot & Co., Joliette, P.Q.  
Gilson Engine Co., Guelph, Ont.

**HARROWS**

Cockshutt Plow Co., Brantford, Ont.  
International Harvester Co., of Can., Ltd., Hamilton, Ont.  
John Deere Mfg. Co., Welland, Ont.  
The Frost & Wood Co., Ltd., Smiths Falls, Ont.

**HAY LOADERS**

International Harvester Co., of Can., Ltd., Hamilton, Ont.  
John Deere Mfg. Co., Welland, Ont.  
The Frost & Wood Co., Ltd., Smiths Falls, Ont.

**HARDWARE**

Aikenhead Hardware Co., Toronto.

**HAY RAKES**

John Deere Mfg. Co., Welland, Ont.  
The Frost & Wood Co., Ltd., Smiths Falls, Ont.

**HAY CARRIERS****HAY PRESSES**

Birdsell Mfg. Co., Toronto.  
International Harvester Co., of Can., Ltd., Hamilton, Ont.

**HULLERS (Clover)**

Birdsell Mfg. Co., Toronto.

**LIGHTNING SYSTEMS**

R. A. Lister Co. (Canada), Ltd., Toronto  
Northern Electric Co., Ltd., Montreal.  
Gilson Engine Co., Guelph, Ont.

**LIME AND FERTILIZER SOWERS**

John Deere Mfg. Co., Welland, Ont.

**LUBRICANTS****MACHINE TOOLS**

Windsor Machine and Tool Works, Windsor, Ontario.

**MANURE CARRIERS****MANURE SPREADERS**

Cockshutt Plow Co., Brantford, Ont.  
International Harvester Co., of Can., Ltd., Hamilton, Ont.  
John Deere Mfg. Co., Welland, Ont.  
The Frost & Wood Co., Ltd., Smiths Falls, Ont.  
Gilson Engine Co., Guelph, Ont.

**MARINE FITTINGS**

Northern Electric Co., Ltd., Montreal.

**MOWERS**

Cockshutt Plow Co., Brantford, Ont.  
International Harvester Co., of Can., Ltd., Hamilton, Ont.  
The Frost & Wood Co., Ltd., Smiths Falls, Ont.

**MOTOR HORNS (Electric)**

Apollo Mfg. Co., Birmingham, Eng.

**MILKING MACHINES**

R. A. Lister Co. (Canada), Ltd., Toronto

**MILLING CUTTERS**

Butterfield & Co., Inc., Rock Island, Q.

**OILS****PISTON RINGS**

Lamontagne Ltd., Montreal, Que.

**PLOWS**

Cockshutt Plow Co., Brantford, Ont.  
John Deere Mfg. Co., Welland, Ont.  
The Frost & Wood Co., Ltd., Smiths Falls, Ont.  
International Harvester Co., of Can., Ltd., Hamilton, Ont.

**POLICE AND FIRE ALARM EQUIPMENT**

Northern Electric Co., Ltd., Montreal.

**POWER AND LIGHT EQUIPMENT**

Northern Electric Co., Ltd., Montreal.  
R. A. Lister Co. of Canada, Ltd., Toronto.

**POWER MACHINERY**

John Deere Mfg. Co., Welland, Ont.  
International Harvester Co., of Can., Ltd., Hamilton, Ont.  
Gilson Engine Co., Guelph, Ont.

**POWER SWITCHBOARDS**

Northern Electric Co., Ltd., Montreal.

**POTATO MACHINERY**

John Deere Mfg. Co., Welland, Ont.  
Cockshutt Plow Co., Brantford, Ont.

**PULVERIZERS**

Cockshutt Plow Co., Brantford, Ont.  
International Harvester Co., of Can., Ltd., Hamilton, Ont.

**PULPERS**

Cockshutt Plow Co., Brantford, Ont.

**RAKES**

International Harvester Co., of Can., Ltd., Hamilton, Ont.  
The Frost & Wood Co., Ltd., Smiths Falls, Ont.

**REAPERS**

International Harvester Co., of Can., Ltd., Hamilton, Ont.  
The Frost & Wood Co., Ltd., Smiths Falls, Ont.

**REAMERS**

Butterfield & Co., Inc., Rock Island, Q.

**ROLLERS**

Cockshutt Plow Co., Brantford, Ont.

**ROLLER BEARINGS****SAW MILL OUTFITS****SCUFFLERS**

Cockshutt Plow Co., Brantford, Ont.  
International Harvester Co., of Can., Ltd., Hamilton, Ont.  
John Deere Mfg. Co., Welland, Ont.

**SEEDERS**

Massey-Harris Co., Toronto.

**SCALES****SCREW PLATES**

Butterfield & Co., Inc., Rock Island, Q.

**STABLE EQUIPMENT****SILOS**

Gilson Mfg. Co., Guelph, Ont.

**SLEIGHS**

Cockshutt Plow Co., Brantford, Ont.  
International Harvester Co., of Can., Ltd., Hamilton, Ont.

**SILO FILLERS**

Gilson Mfg. Co., Guelph, Ont.  
International Harvester Co., of Can., Ltd., Hamilton, Ont.

**SOCKET WRENCHES**

R. F. Sedgley, Inc., Philadelphia, Pa.

**SEPARATORS (CREAM)**

R. A. Lister Co., Toronto.

**SPREADERS, MANURE**

Cockshutt Plow Co., Brantford, Ont.  
John Deere Mfg. Co., Welland, Ont.  
International Harvester Co., of Can., Ltd., Hamilton, Ont.  
Massey-Harris Co., Toronto.  
Gilson Mfg. Co., Guelph, Ont.

**SPARK PLUGS**

Machine & Stamping Co., Toronto.  
Champion Spark Plug Co., Windsor, O.  
Apollo Plug Mfg. Co., Birmingham, Eng.  
Can. General Electric Co., Ltd., Toronto.

**SPARK PLUG CLEANERS**

Champion Spark Plug Co., Windsor, O.

**STAMPINGS****TELEPHONE APPARATUS**

Northern Electric Co., Ltd., Montreal.

**TRACTORS**

R. A. Lister Co. (Canada), Ltd., Toronto  
Gilson Mfg. Co., Guelph, Ont.  
International Harvester Co., of Can., Ltd., Hamilton, Ont.  
J. I. Case Threshing Machine Co., Inc., Racine, Wis.  
Massey-Harris Co., Toronto.  
The Turner Mfg. Co., Port Washington, Wis.

**TRACTOR PLOWS**

Cockshutt Plow Co., Brantford, Ont.  
International Harvester Co., of Can., Ltd., Hamilton, Ont.  
John Deere Mfg. Co., Welland, Ont.  
Massey-Harris Co., Toronto.

**TIRES****THRESHERS**

Can. Fairbanks-Morse Co., Ltd., Montreal.  
International Harvester Co., of Can., Ltd., Hamilton, Ont.  
J. I. Case Threshing Machine Co., Inc., Racine, Wis.  
R. A. Lister Co. (Canada), Ltd., Toronto  
Gilson Mfg. Co., Guelph, Ont.

**THREAD CUTTING TAPS**

Butterfield & Co., Inc., Rock Island, Q.

**TWIST DRILLS**

Butterfield & Co., Inc., Rock Island, Q.

**TRUCKS**

Motor Car Distributors Ltd., Montreal.  
Eastern Canada Motor Truck Co., Ltd., Hull, P.Q.  
International Harvester Co., of Can., Ltd., Hamilton, Ont.

**WHEELBARROWS**

Cockshutt Plow Co., Brantford, Ont.  
Massey-Harris Co., Toronto.

**WAGONS**

Cockshutt Plow Co., Brantford, Ont.  
International Harvester Co., of Can., Ltd., Hamilton, Ont.  
Massey-Harris Co., Toronto.

**WATER BOWLS****WEEDERS**

Cockshutt Plow Co., Brantford, Ont.

**WIRES AND CABLES**

Northern Electric Co., Ltd., Montreal



# Butterfield

The Butterfield Reputation has been built up by Butterfield Character which is built in.

And that character built in marks the difference between Butterfield value and ordinary value. A difference expressed in better service for a longer time.

*"The Tools  
You Buy  
Again"*

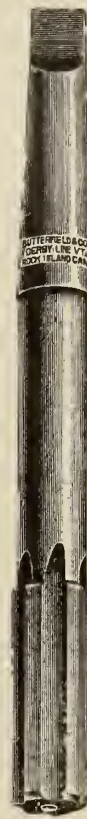
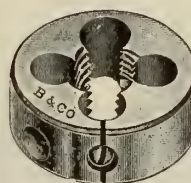
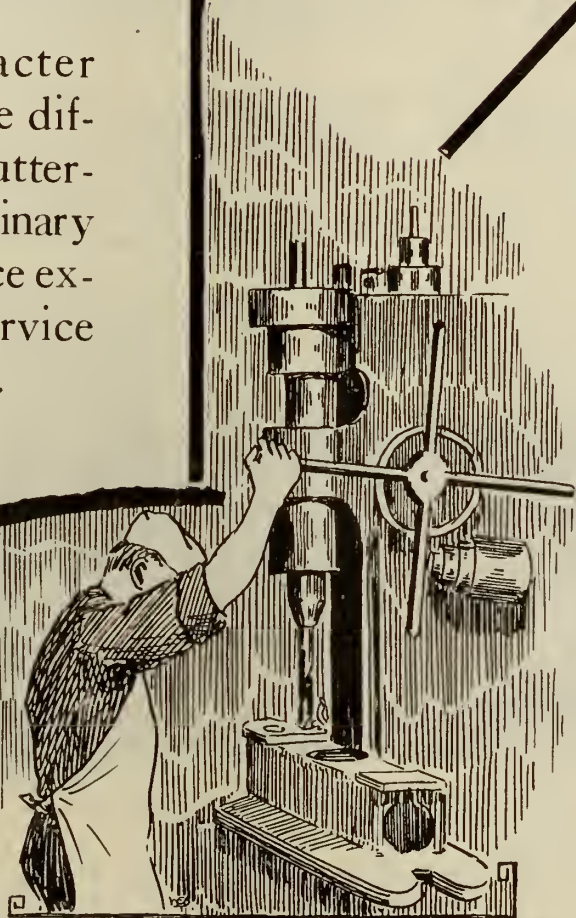

**TAPS  
DIES  
REAMERS  
MILLING CUTTERS**

To do the best work one must have the best tools. And that's sufficient reason, don't you think, for using Butterfield Tools?

**BUTTERFIELD & COMPANY, *Division***

**UNION TWIST DRILL CO.**

**ROCK ISLAND**

**QUEBEC**

TORONTO OFFICE: 220 KING ST. WEST



## NATURAL RESOURCES OF NOVA SCOTIA

A 70-page booklet entitled "Natural Resources of Nova Scotia," with 16 illustrations and a map has just been issued by the Natural Resources Intelligence Branch of the Department of the Interior, Ottawa. This is the latest of a series dealing with various sections of the Dominion, the booklets previously issued having dealt with New Brunswick, the Peace River, New Manitoba, Saskatchewan, etc.

The opening paragraph clearly indicates the object of the series when it says: "The facts in this booklet are compiled for the use of the home-seeker, merchant, manufacturer, capitalist and visitor. They purpose to be up-to-date, authoritative, concise." Each booklet forms a basis of standard official information and is revised as each edition is exhausted.

In the booklet a welcome absence of verbiage allows space for valuable specific facts. Thus there is a list of products reshipped from Halifax which could easily be manufactured in Canada; a special section on West Indian and British Guiana trade, details about oil-shales, coal, limestone and iron, aeronautics, merchant marine, clays, salt, land prices and wages—all subjects of present interest. Statistics are made palatable by an interesting style and suggestive touches.

Nova Scotia is crossing the threshold to great activities and both to the many native born who left the land in the last generation and to the many about to sail from overseas the booklet will be a reminder that the chances in Nova Scotia now seem as bright as is its summer beauty. The "Natural Resources of Nova Scotia" will be sent free by mail on application to the Superintendent, Natural Resources Intelligence Branch, Department of the Interior, Ottawa.

## ADVERTISING FOR THE IMPLEMENT DEALER

(Continued from page 13)

earned in their purchases to a certain extent by such advertising is no reason that the advertising isn't effective. In Chicago is a mail-order house that does a business of one million dollars a day. — entirely the result of advertising. Whether the advertising medium happens to be catalogs or newspaper space makes little difference—the idea is the same—selling the prospect by means of the printed word and attractive illustrations.

That brings us to the dealer who doesn't do much advertising because he doesn't consider himself capable of preparing advertisement that will prove resultful and the dealer who is too busy to bother. But these are no excuses—the dealer doesn't have to know anything about advertising and he can advertise effectively no matter how busy he may be. The big implement manufacturers are willing and eager to relieve the local dealer of this task. They will furnish him with complete, plated advertisements, in electrotyping form, with a space mortised out at the bottom of the ad to receive the local dealer's name and address, which is set in type by the local paper. Neither the preparation of such advertisements nor the electrotyping cost the dealer a copper—the manufacturer absorbs this expense. All the dealer is called upon to do is to pay the very nominal bill of the local paper for the space used. And yet many dealers refuse to take advantage of such co-operation for their own benefit.

## Advertising Increases Sales

Every dealer, of course, is anxious to increase his sales volume. At the same time he often hesitates to make use of the mediums conveniently placed at his disposal. If you are out to increase your volume make it a worthwhile increase—and let advertising help you make it. Of course it is possible to increase your sales without advertising if you substitute personal effort in its place, but advertising is the tonic that always livens up business when it's

weak and makes strong business stronger.

Make your goal a one hundred per cent. increase—but not the kind that the dealer made who attended an implement dealers' convention not long ago. This dealer announced that he had increased his cream separator sales 100 per cent. during the past year. When asked how many separators he had sold to attain this desirable increase he stated:—"Not any." This paradoxical statement naturally required further elucidation—so the dealer explained thusly:

"Well, you see it was like this: Two years ago I took one separator back—one that I sold the year before. But this last year I didn't take any back and I didn't sell any so I figure I increased my separator sales 100 per cent. for this year. How's that?"

Pretty rotten, eh? We'll say so! Between you and me and your last summer's straw hat I don't mind telling you that this dealer didn't believe in advertising!

## REISNER WITH DE LAVAL

C. L. REISNER, formerly connected with the advertising department of the Moline Plow Co., Moline, Ill., has been appointed advertising manager of the De Laval Separator Co., New York. Mr. Reisner is one of the most capable men in the farm equipment advertising field and well qualified to handle the publicity of the De Laval company.



Wm. Nussey, of Howick, Que., with the team and plow of Lawrence T. Brown, Franklin Centre, Que., winner in the class of plain walking plows at Macdonald College.

## DETAILS IN TIRE REPAIRING

(Continued from page 9)

only if the original base is entirely undamaged. If the canvas has been worn through, retreading will do no good. So a retread may save considerable money or it may simply be money wasted, because the carcass was not worth the retread applied to it. Therefore, in selecting a tire for retreading, one should be positively sure that the canvas base is absolutely undamaged. It is not always possible to detect damage to the carcass by cursory examination or by feeling of the casing. For that reason you find many owners who declare retreading a swindle, while others are strongly for it. It is merely a question of damaged or perfect carcasses.

A good many repairmen make a practice of having retreading done over an old tread that has worn smooth. This is not at all a bad plan, but if the wear on the original tread has been uneven, one will get a bumpy, uneven surface which will not make for long wear. When this extra tread is applied over an original tread, naturally the tire loses something in resiliency, even if the pressure in it is reduced ten pounds, which is commonly done. However, many owners do this and find that it gives them a largely augmented mileage per tire. Another method of extracting extra mileage from a tire that has begun to wear considerably is to put in an inner-lining. This device is simply a strip of fabric, which is placed between the tube and the cas-

ing. Its function is to act as an extra strip of fabric in the casing.

Tires are one of the biggest items in the expense of running a motor car. In the case of the average motor car owner, the tire item is even bigger than it need be because he fails to heed two warnings that are constantly dinned into his ears by repairmen but which he neglects just the same. One of these is in regard to keeping the proper pressure always in the casing, and the second is in regard to keeping the tread intact. That is to say, having all holes and cuts plugged as quickly as they appear. The tread protects the base of the tire, the canvas fabric, from water, etc., and if cuts remain unfilled water gets in and rots the canvas, after which the tire rapidly goes to pieces. The importance of the tire question is easily judged by the number of advertisements that appear in the papers and magazines of tire accessories of various sorts. Naturally, the makers of these inform the public that their use will enable said public to get the very last yard of mileage out of every tire. They may, but not unless the two basic rules quoted above are followed.

## OPEN FACTORIES IN ENGLAND AND FRANCE

GEORGE H. TOWNSEND, President, and E. V. Hennecke, Sales Manager, of the Moto-Meter Company, Inc., sailed on the "Imperator" on Thursday, October 7th, for Southampton, Eng-

to be marked down ten cents a yard and all the silks ten cents a yard up. The store was filled with eager women anxious to snap up the silk before the price was raised, and rushing to buy the cotton while the buying was good and there was any cotton left before the waiting mob had its chance at the lower price.

The advertising man sauntered through the store to get his statistics at first hand and was nearly killed in the frantic struggle between the bulls and the bears. He spent a week in the hospital reading books on economics and afterwards published a little essay on the workings of the feminine mind.

Suburban grocers are advertising that you can buy all the sugar you want at fourteen cents, and the puzzled housewives are trying to make out whether the grocers are attempting to unload or whether it is a real bargain. The result is a waiting market.

The average man's idea of an attractive price system is one of prevailing uniformity. Women are commonly supposed, whether correctly or not is not known to man, to be attracted by violent fluctuations. Observation shows that as a rule women make money go farther than men.

The moral is that in automobiles it is recognized that it is the women who have most to say about the purchase of cars and that no one knows what an automobile is worth.—Commerce and Finance.

## REDUCE WORKING TIME TO FOUR DAYS

OWING to depressed trade conditions the management of the plant of the Ford Motor Car Company of Canada have found it necessary to curtail output, and to this end have issued instructions that the working time of the factory will be reduced to four days a week.

## SASKATCHEWAN ELEVATOR CO.

A REPORT to the provincial department shows that in 1919 the Saskatchewan Co-operative Elevator Co. operated 308 elevators, handled 21,841,556 bushels of grain, made a profit of \$193,599, declared a dividend of 8 per cent. and transferred \$36,446 to the reserve fund.

## SAFETY FIRST

Lies slumbering here  
One William Lake;  
He heard the bell,  
But had no brake.  
—Detroit News.

At fifty miles  
Drove Ollie Pidd;  
He thought he wouldn't  
Skid but did.  
—Rome, N. Y., Sentinel

At ninety miles  
Drove Edward Shawn;  
The motor stopped,  
But Ed. kept on.  
—Little Falls, N. Y., Times

Beneath this sod  
Lies William Whissen.  
He didn't stop  
To look and listen.  
—Ohio Motorist

Here, six feet deep,  
Is William Jolley,  
His engine stalled  
In front of a trolley.  
—Omaha Transmission

Ashes to ashes  
And dust to dust,  
Bill was showing speed  
When a tire "bust."  
—Exc.

Chance thought he could  
Beat the Limited;  
He started thru space  
At the crossing instead.

land. They will visit England and France for the purpose of establishing branch factories which will produce Boyce Moto-Meters for the European market and will also make a survey of the general conditions affecting the future of the automobile trade in Great Britain and on the Continent.

## PANCHO VILLA BECOMES FARMER

UNDER the agreement Pancho Villa has with the Mexican Government, he has agreed to become a farmer and the Government has furnished him with a large farm and agrees to properly equip it.

One of the first moves of the Government was to secure a Lauson Tractor for Villa through the Lauson distributors, Lone Star Motor Company, of El Paso, Texas.

## CATCHING THEM COMING AND GOING

A PRETTY race is on between automobile manufacturers who are announcing reductions in the price of their cars and those who are announcing increases. There is material for good selling talk in both policies.

We recall a department store that advertised that during a certain day there would be a change made every hour in the selling price of its silk and cotton goods. Promptly on the stroke of each hour all the cotton goods were





# Champion

## Priming Plugs

### Cold Weather Spark Plugs

Every motor car owner needs Champion Priming Plugs in his motor from now till the end of cold weather.

They put quick life into a cold motor, insure a prompt, sure start—because they place the gasoline right into the heart of each cylinder, where it catches the spark at the first turn of the engine.

Champion Priming Plugs not only make it easy to run a car all winter, but they eliminate unnecessary cranking, conserve gasoline and minimize wear and tear on starter and batteries.

Champion Priming Plugs are all equipped with our famous "3450" insulators, which have demonstrated their ability to withstand quick changes from zero cold to intense heat and have a breakage resistance to shock, and vibration which makes them practically indestructible.

Champion Priming Plugs maintain your spark plug sales during the winter season. It's good business to have a stock on hand to give a better service to your customers. They will expect you to be able to supply them.

*Order them from your jobber to-day*

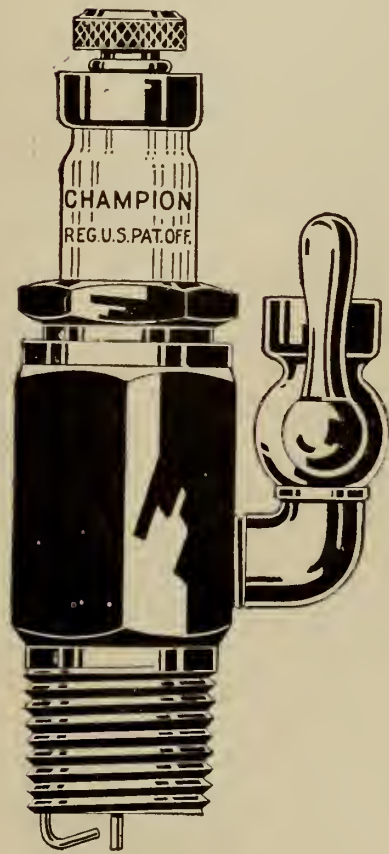

**Champion  
Priming Plug**

H-14,  $\frac{1}{2}$  inch  
H-44,  $\frac{7}{8}$  inch-18

Price, \$1.50

**Champion Spark Plug Co. of Canada, Limited**  
**Windsor, Ontario**

*Largest factory in Canada making Spark Plugs exclusively  
and the only one making "Champions."*



# Make 1921 your biggest year

*The reputation of Jumbo Trucks  
will help you do it. Not a dis-  
satisfied Jumbo owner that we  
know of in all the world.*

The good will of satisfied owners is more essential for a substantial future than the big profits of undersize construction—*The Jumbo Creed.*

Jumbo Trucks in operation prove the wisdom of this policy. Records of 20,000 to 30,000 miles without a cent for repairs—without even changing tires—are common to Jumbo owners.

That's because Jumbo Trucks are built with *a large factor of safety* and survive the abuse of heavy haulage.

The Jumbo dealer renders truck buyers a definite service and profits thereby—not only today, but for years to come.

These facts comprise but a small part of the Jumbo story. We believe we can convince any alert dealer of the exceptional future offered by Jumbo Trucks.

*Jumbo Trucks  
Always Come Through*

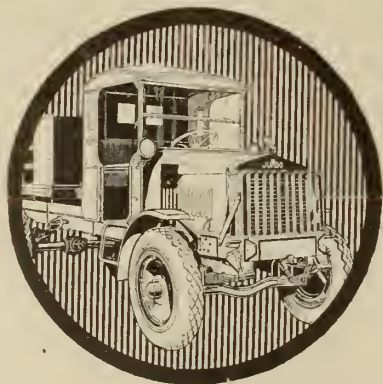

MANUFACTURED BY  
NELSON MOTOR TRUCK COMPANY  
SAGINAW, MICHIGAN, U. S. A.

*Write for full facts and sales plan*

*Sole Distributors in Canada*

**MOTOR CAR DISTRIBUTORS  
LIMITED**

27 McGill College Ave. Montreal, Que.

***THE Complete Truck***

**JUMBO**  
*The Complete Truck*



CANADIAN  
MOTOR, TRACTOR AND IMPLEMENT  
TRADE JOURNAL

Published Monthly by THE MACLEAN PUBLISHING COMPANY, LIMITED, TORONTO

MONTREAL, Southam Bldg.

WINNIPEG, 1103 Union Trust Bldg.  
NEW YORK, 1133 Broadway.

VANCOUVER, 314 Carter-Cotton Bldg., 198 Hastings St. W.  
BOSTON, 734 Old South Bldg. CHICAGO, 405-6 Transportation Bldg.

LONDON, ENG., 88 Fleet St., E.C. 4

VOL. II, No. 12

TORONTO, DECEMBER, 1920

Subscription Price  
\$2.00 Per Year



**Raybestos**

**BRAKE  
LINING**

**B**RAKE LINING that does not WEAR well is a loss at any cost. You pay to put it on and you pay again to rip it out. For heavy duty, use Raybestos, the lining that is built for sturdy WEAR. Look for the Silver Edge.

THE CANADIAN RAYBESTOS CO.  
Peterborough Limited Ontario

*Canadian Made  
for  
Canadian Trade*



# VETERAN TRUCKS

For Continuous Service and Reliability



Built with Standard Units. Not merely assembled. Every Unit made especially or selected because of past performance. The result, a Sturdy Wearing Truck that stands up under hard, continuous Service.

**EASTERN CANADA MOTOR TRUCK CO.**

HULL, Limited QUE.

**Commercial Cars Limited, Toronto**

Distributors for Western Ontario, Manitoba, Saskatchewan, and British Columbia



# Sell The Engine That Is Already Half Sold

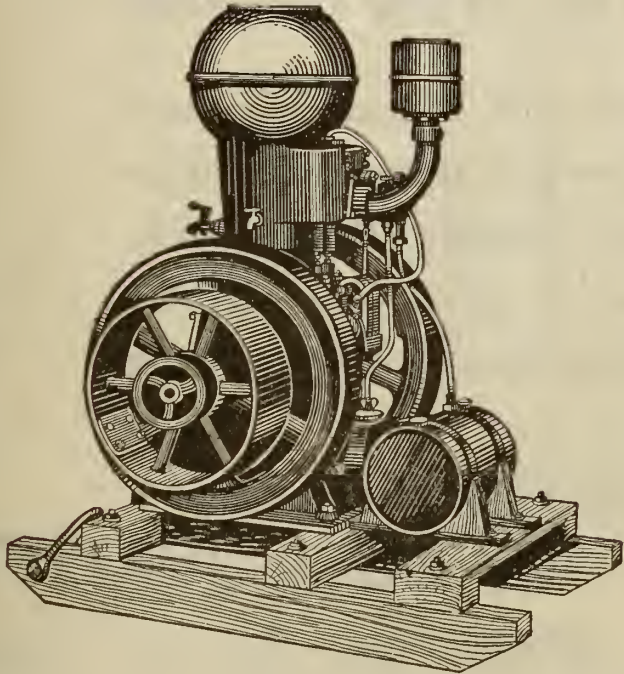

Power on the farm is the common need of every farmer. Every farmer in Canada has full confidence in British Reliability. The reputation of the Lister Engine for dependable quality and performance is everywhere accepted. By selling the Lister you are working in selling ground that is cultivated and ready for a real harvest of sales.

The Lister Engine embodies the latest ideas in farm engine construction. It bears the stamp of thoroughness and quality associated with goods of British manufacture throughout the world.

The Lister is a genuine fuel saver. When the hard tests come, Lister Quality stands supreme. This means that your customers to whom you have sold Lister Engines are satisfied customers who will come back to you for other goods.

2-3-5-7 and 9 horse power; standard hopper cooled; throttle governed; automatic lubrication; high tension magneto—a genuinely reliable engine throughout.

## The Lister Grinder

The farmer's time is too precious to use anything but the most reliable grinder his money can buy. We guarantee that the Lister will do more work (all conditions being equal) than any other make.

## The Lister Milker

A perfected, up-to-date machine on which your customers can absolutely rely. Experience has taught us the need for SIMPLICITY in a milker, combined with ease of cleaning. The Lister embodies these essential features. One of the greatest sellers in the Farm Machinery business.

## The Melotte Cream Separator

Known as a Canada-wide favorite—with good reason. A marvel of skimming efficiency that has stood the special tests peculiar to every country in the world. Capacities 280 to 1300 lbs. per hour. Many have run for 25 years without expense other than rubber rings and oil. Easy to run—easy to clean, and will give a lifetime of dependable service. Write for literature.

## Other Lister Lines

**Lister Ensilage  
Cutters**

**Lister Premier  
Cream Separator**

**Avery Tractors**

(A size for every farm)

*Resolve Now to Sell the "Good Old Lister Reliability  
Lines" next year. Write for literature and  
attractive selling proposition*

**R. A. Lister & Company (Canada) Limited**

58-60 Stewart Street, Toronto

Wall Street, Winnipeg



*You've Waited For This!*

# Smash Go Engine Prices

**Gilson Creates a Sensation by Slashing Prices to Pre-War Levels on New Engine**

**N**OW'S your chance to jump in with the Gilson line and clear up a bunch of money. You've got dozens of prospects for engines. PRICE has been holding them back. Now you can sell them an engine at a price you haven't quoted since 1914—a price lower than the lowest on the market.

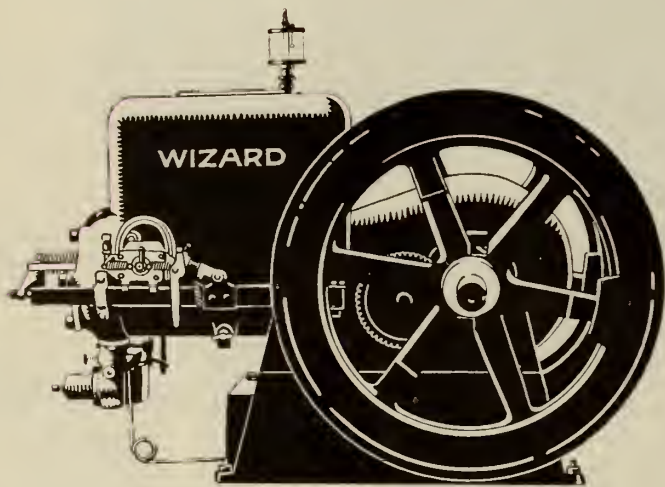

**DOWN GO PRICES—  
UP GOES QUALITY**

**T**HE "Wizard" line—the latest Gilson product—sets new standards of performance. Runs on cheap kerosene. Built-in magneto means easy starting and fuel economy. Throttle-governed. Big surplus power over rating—like all Gilson engines. Backed by a five-year guarantee. Though the price is lower than the lowest, you can safely invite comparison with any other engine at any price—for dependability, economical upkeep and service.

## Get the Cream of the Business

**Send This Coupon**

Gilson Mfg. Co., Limited

Gentlemen,—

I would like full facts on your dealers' proposition on the "Wizard" engine. Also send me the Gilson proposition on  Silos  Silo Fillers  Tractors  Threshers.

Name.....

Address.....

*Write for full facts at once. Prices are rock bottom now. Can't get lower. May be higher. A size for every need—1¾, 3½ and 6 H.P. You can offer FREE TRIAL and EASY TERMS. Who couldn't sell such an engine on such a basis? Get in with a running start.*

Advertising now appearing in all leading publications. Demand is pouring in. Be wise---and act now. Be the first in your territory to quote pre-war prices. Send a postcard at once.

**GILSON** Mfg. Co., Limited  
9618 York Street, Guelph  
325 Elgin Avenue, Winnipeg



# Factors You Should Consider In Selling Farm Implements

Now is the time to consider the line of Farm Implement you want to handle in 1921. To be interesting and profitable the line you handle should have these features:

It should sell on its merits. You can take any Implement in the John Deere line, compare it point for point with other makes and the John Deere Implement will sell on its merits.

A demonstration should back up all claims. Any claim you make regarding John Deere Implements is readily backed up by a demonstration.

The manufacturer should have a reputation for dependability and reliability. When you sell John Deere lines you have back of you a prestige that is country-wide. John Deere Implements are known everywhere for their sound construction, ease of handling and labor-saving qualities.

There should be ample profit for you. The John Deere dealer proposition is liberal and assures ample profits. John Deere Implements are sold through John Deere dealers only. Dealers are given every opportunity to take advantage of their own initiative and to cash in on their sales ability.

The line should be advertised. All live farm publications in Ontario carry continuous advertising on all John Deere products.

*Territories are still open for live dealers. It will pay you to write for our 1921 contract and sales proposition.*

## "Quality Line of Farm Implements"

John Deere Low-Down Manure Spreader; John Deere-Dain Left-hand Side Delivery Rakes; John Deere-Dain Rake-bar Hay-Loader; John Deere-Dain Sulky-Rake; John Deere-Dain Vertical-Lift Mowers; John Deere-Van-Brunt Plain Grain Drills; John Deere-Van-Brunt Fertilizer Drills; John Deere-Van-Brunt One-Horse Drills; John Deere-Van-Brunt Lime and Fertilizer Sowers; John Deere No. 999 Corn Planters; John Deere Cultivators; John Deere Scufflers; John Deere Smoothing Harrows; John Deere Spring-Tooth Harrows; John Deere Disc Harrows (Horse or Tractor); John Deere Field Cultivators; John Deere Beet Tools (Planters, Cultivators, Pullers); Hoover Potato Machinery (Planters, Sorters, Cutters, Diggers); "Reliance" Potato and Field Sprayers; "Waterloo Boy" Kerosene Engines; John Deere Walking Plows; John Deere One-Way Plows; New Deere Sulkies and Gangs; John Deere Contractors' Plows; John Deere Tractor Plows.

# THE JOHN DEERE MANUFACTURING CO., LIMITED

Welland  Ontario



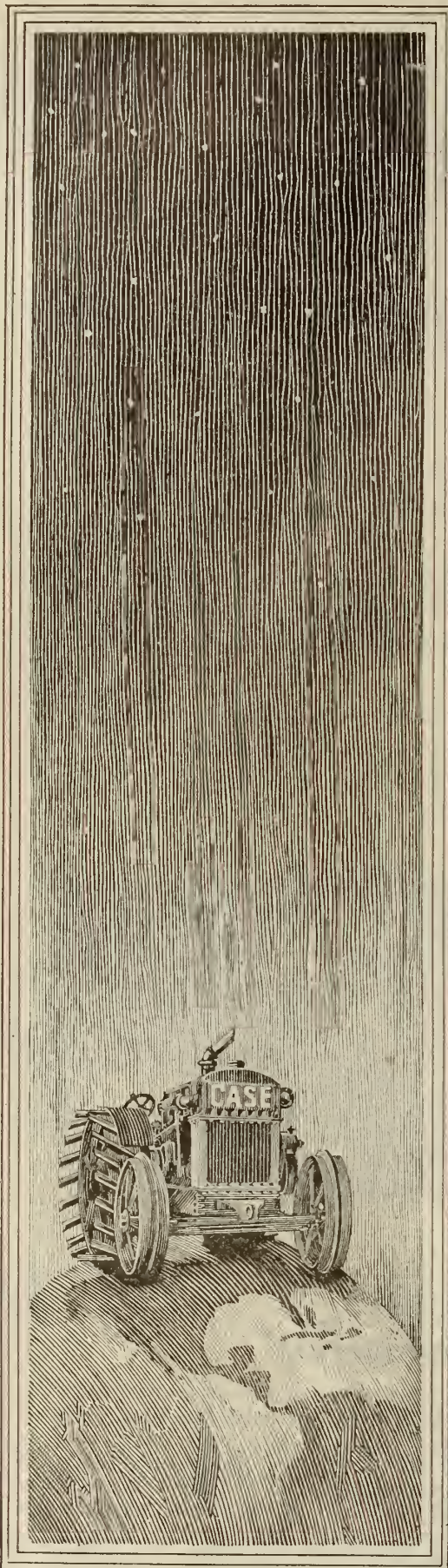

# Greetings!

## "The World Over"

TO you men, who stand loyally back of the efforts to promote the sale of agricultural implements we send our heartiest Yuletide greetings.

Wherever farm machinery goes, you first must blaze the way, making new friends year by year.

Your fine standards of salesmanship, your ideals and your loyalty to the farm implement industry have done much to make agriculture the success it is today.

In all good fellowship and friendliness, we wish the Farm Implement Dealers, the world over, a jolly, old-fashioned "Merry Christmas."

**J. I. Case Threshing Machine Company**  
Racine, Wis.





# CANADIAN MOTOR, TRACTOR AND IMPLEMENT TRADE JOURNAL

Volume 2

TORONTO, DECEMBER, 1920

Number 12

## Are You a Power Farming Specialist?

The Man Who Specializes To-day is the Man Who is Winning Out. Best Results Are Achieved When Your Business is Departmentalized

**I**N this enlightened day and age the man who attempts to be a business jack-of-all-trades seldom, if ever, makes a great success of it. He must specialize if he is to stand out in his community. This has been the experience of professional men and of retail merchants in every line and it applies with even greater force to the man who is handling tractors and power farming machinery. The power farming business, while much younger and less developed than other lines of automotive effort, has every opportunity of becoming one of the leading businesses in every rural trading centre if those who are engaged in it will realize the necessity and the value of specialization.

Power farming dealers are for the most part drawn from three classes—the implement dealer or general merchant; the automotive and truck dealer; the individual investor who is seeking a permanent business into which to put his money and his ability. In the case of the implement man or general merchant the addition of the tractor and of power implements has been gradual and without a definite goal, save the rounding out of a line. But those implement dealers who have studied their power farming equipment and the importance of power farming have quickly departmentalized their business and separated the power line from the horse-drawn implements.

There is a vast difference between sale and operation of speed gang plows and the walking or sulky plow and this difference is reflected to a less degree in almost every implement carried. Power farming sets new standards for the farmer, the dealer and the manufacturer and the real successes in both the power and horse-drawn business are achieved when the selling organizations are separate and distinct.

And there will be even greater need of specialization as the use of the small, all-purpose tractor becomes more and more general. The competition between the horse and the tractor is purely economic—both will continue to have advantages in certain localities and for certain work for many years to come. Horse and power implements have their well-defined markets—often on the same farms—but it is too much to expect a single organization to exploit both lines. The study of farm conditions, the organization of farm work and the service required in both lines, demand that each be given the place of first importance in its marketing organization.

**T**HEN, too, there is the industrial field to consider. Certain types of small tractors are finding a ready market for road building, lumbering, general contracting and in industrial plants. Material handling

By **EARL B. STONE**

ASSIST. ADVTG. MANAGER, THE CLEVELAND TRACTOR CO.



The Optimist.

—Knott in the Dallas "News."

equipment, road machinery, and factory trucks logically become a part of the tractor dealer line and men of special training are required to handle this business. Here again is a potent reason for the separation of the power from the horse equipment. The successful power farming dealer whose business background is made up of implement and general merchandising experience is now carefully defining his power farming business and basing his sales work upon a strictly power line. He is specializing and he is making money.

It is interesting to note as we turn to the automobile and truck dealers that many who first entered the power farming field came in without any great hope of a permanent and growing tractor business. Business conditions made immediate tractor profits desirable and many contracts were signed with a skeptical pen and half-hearted enthusiasm. True, some of these dealers verified their doubts and have since given up their power farming line, but as many and more, paralleling the experience of their implement friends, have built up separate power farming departments and realized handsome profits.

Close as the relationship of all automotive equip-

ment may seem, it is not close enough to bring success to a single sales force which attempts to handle both tractors and automobiles. Not a few auto dealers have deserted their former connection completely in favor of the tractor business, but the majority have separated their lines and are pushing each line with an individual selling organization. From the auto dealer in the small rural town to the large distributor in the greatest cities in the country this method of specialization has proved to be the only practical method of handling both the automobile line and the power farming line successfully.

In the matter of service to the owner the dealer's service department functions equally well for both lines, but in the study of the market and the development of new business separate organizations are the surest way to success.

Now, in the consideration of the independent investor we have a clear slate to start with and specialization is the natural trend. The organization of a new power farming business permits of a choice of both the tractor and the power machinery which are suited to the locality in every way. There are no embarrassing connections which must be dropped or strained to get the right power farming line. There is no old organization to split up and departmentalize.

**A**S the basis of the power farming business is the tractor, its selection is of first importance. The tractor which will do the work on the individual farm, which can be adapted to the greater variety of farming and soil conditions and which is backed by the most aggressive and enduring organization, is the one to select.

To this then is added tillage tools, haying and harvesting machinery, belt-driven farm machinery and even material handling and road-working equipment—for the right tractor will have an industrial as well as a farm application. And the line may include farm lighting plants as well, for they rightfully belong in a business which is dealing in power to replace the hard labor of men and animals and improve farm conditions generally.

The independent investor was the first to become the one hundred per cent. power farming dealer and his success has been the guide to both implement and automobile dealers in their steps toward specialization.

He has found—and the dealers who are taking on power farming lines are finding—that specialization alone will assure lasting profits, for only by the undivided efforts of a complete organization can the big power farming market be cultivated successfully.

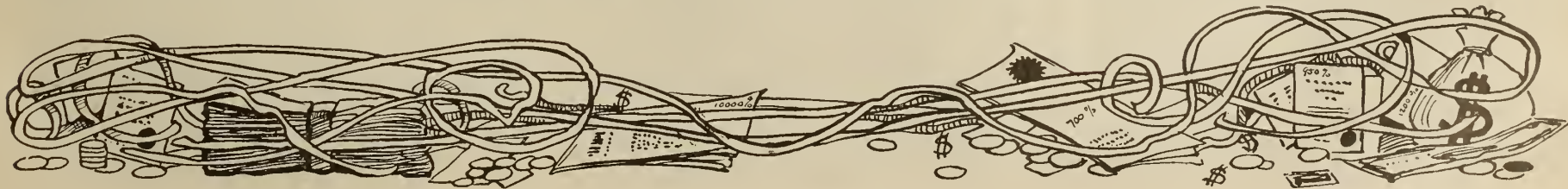



# Success by Helping the Other Fellow

## How a Dealer Built Up a Strong Automobile and Accessory Business by Giving a Real Service is Told Herein

"If a man would succeed in the automobile or any other business, he must sell what the public wants, and when it wants it." The speaker was C. A. McDonell, of McDonell Bros., automobile, accessory and tire dealers of Hensall, Ontario.

The M. T. I. representative had learned that the McDonell brothers were real live dealers who were meeting with success, so he packed his grip and journeyed forth to see for himself. He was not disappointed, and learned a few things which he will endeavor to pass on to M. T. I. readers.

In the first place, Hensall is a small town—we almost said a "one horse" town—of about 800 population, situated in a good mixed farming district—Hensall folks claim, like a great many other town folks, that their's is the "best farming district." As McDonell Bros. have sold as many as a hundred cars and hundreds of dollars' worth of accessories and tires in one year it is obvious that Hensall alone does not supply all the customers. The farmers, of course, form the bulk of the prospects, but McDonell Bros. sell to the surrounding towns also. They have the exclusive agency for a certain car and line of accessories, and supply these to other dealers in neighboring towns within a radius of 20 miles.

### Hardware Until 1915

Their business was started in 1915. Previous to that they conducted a hardware store for thirty-seven years and the reputation they gained during these years for good service and sound business tactics has helped them to build up their present fine garage connection. The garage has an excellent location, situated on the principal street, and this being part of the main highway used by motorists a great deal of tourist trade is attracted to their door during the motoring months.

McDonell Bros. make a point of keeping a complete stock of accessories, tires and parts in stock all the year round. Their window is used to display in an attractive manner whatever they may be featuring at the time. The accessories are arranged in boxes along one side of the wall, and in a show case. The larger parts, such as axles, fenders, etc., find a place on the floor underneath the boxes, neatly divided according to the different parts.

The accessories are very accessible and catalogued in an interesting manner. Using the manufacturers' catalogue all of the small accessories listed are arranged in the boxes according to the number of the page in the catalogue. For instance, the accessories listed on, say, page 10, are placed in the box marked 10. The parts that are too large to go in the box are put in an open compartment on the floor immediately under the box containing the same page number. In this way McDonell Bros. say a child could find any part in a few moments. The parts in the showcase or window are marked in the catalogue "showcase" or "window."

### Everything Motorist Requires

McDonell Bros. pride themselves on having in stock everything a motorist requires. Occasionally they have been asked for a certain part which they hadn't on hand at the time. In that case they sent for it immediately, paying all correspondence and transportation costs themselves and delivering it to the customer, no matter how small or how large the part may have been. If it was a part which they had allowed to run out of stock they immediately restocked that particular line. If it happened to be a part which was new to them and worth handling they invariably included it in their stock.

By keeping their finger on the customer's pulse they have been able to build up a large accessory business. They receive telephone calls almost every day from the surrounding towns for accessories. Each call as it comes in is attended to at once, and if it is from an outside address the goods are sent by the first train leaving for that particular place. By giving their prompt service to their outside customers and always having the goods on hand they have secured a large volume of sales which might have gone to the dealers in these towns.



This picture shows McDonell Bros.' garage. C. A. McDonell is at the door.

### Extending Premises

McDonell Bros. at one time let out all their repair work. They felt it would pay them to concentrate their attention entirely on the automobile and accessory end of their business, so they turned all their repairs over to another garage. However, this arrangement did not prove satisfactory. There were many service complaints, and numerous readjustments had to be made. As they believe a business is built up by satisfying customers they decided to do their own repair work and fitted up a workroom to that end. Now their business has grown so that the present premises are no longer large enough for their needs. They intend to enlarge their premises in the near future. This will be done by extensions to the repair room at the rear. In connection with this extension McDonell Bros. have a novel idea to get more space and to do away with an elevator. The new part to be added will be built with the roof sloping like a wedge from the ground to the second story. It is the intention to use this roof as a driveway for cars up to the second floor. The second floor—which is now used for storing large repair parts—will be used for a paint shop and for storing cars.

"Our repair department heretofore has been mainly used for the purpose of servicing our own cars, said C. A. McDonell. "We did not pretend to give a regular repair service, but the business is growing so rapidly and the need for a proper service so important we are practically compelled to go into the repair work on a larger scale.

### Service Counts

"We are convinced that real service is the only thing that counts in building up an automobile business. That has been amply demonstrated to us through our accessory department. We are proud to say that a man seldom leaves our door because we don't have the goods on hand he wants. If a man should ask for an article we don't have in stock, we get it for him, even though it costs us money accommodating him. We consider we should have on hand all the time everything a motorist requires and if we lose on a sale because of express charges, etc., it is our own fault and we are willing to pay for our lessons.

"The years we were in the hardware business have supplied us with most of our prospects. We tried to satisfy our customers then and have reason

to believe our efforts were appreciated and are bearing fruit in our automobile business.

### Don't Bury Prospect in Details

"When endeavoring to sell a man a car we don't believe in weighing him down with a long and bewildering talk on details of design, etc. To a man who knows nothing about a car such a talk might well be delivered in Greek for all the good he will get out of it. In fact you leave him, in most cases, knowing less about the matter than before you spoke to him. We have found that the best way is to base our talk on the need the man has for a car, and after talking to him in this strain we give him some literature to study at leisure and advise him to talk with some of our car owners—the addresses of whom we give him—then leave him for a time.

"In every case we have found this to be a good plan. Of course, the success or failure of the above scheme depends on the quality of the goods handled and the kind of service given. The next time we go back to see our man he has learned something about the car, our methods of doing business and the kind of service he can expect. It is easier to sell him then—and we generally do.

"When customers get good, prompt service, they are satisfied and become boosters. We work on that theory and are satisfied it is right.

### Help Customers Get Adjustments

"If we see a car on the street with tires in need of repairs we talk to the owner about it and advise him in the matter. We have made a lot of good friends by this policy, and also by helping a man to get a tire adjustment. It doesn't make any difference where he bought the tires in the first place, we are out to help everybody. It isn't that we are more philanthropic than our neighbors or that we are merely making good fellows of ourselves, it is good business.

"Recently a man came into our place with two tires which he said were defective and wanted to know if we could get an adjustment for him—he didn't buy the tires from us. After examining them we said we would do what we could to arrange the adjustment. That seemed to please him for he immediately bought and paid for two new tires and thanked us for helping him out of his trouble.

"We are thoroughly convinced that by having the goods on hand all of the time, and by giving the best service possible the automotive dealer is sure to make friends; and by making friends he is making customers and building up his business on a sure foundation."

### Agriculture Basic Industry

"TOO many business men, I am afraid, have failed to appreciate fully the importance of agriculture or their dependence on it. This has resulted, in many instances, in lack of sympathetic understanding of the farmer's problems and of the difficulties confronting him not only in producing his crops or livestock, but also in the marketing of his products. Agriculture furnishes the basis of much of the business of the country. There are many industries which are entirely dependent on it, such as the manufacture of farm implements and machinery, the packing houses, the grain merchants and many others; and farm products, of course play a large part in transportation. Neither the business man nor the farmer, therefore, can be genuinely and permanently prosperous without the good will and the material aid of the other. Whenever a business man does anything toward making the agriculture of his section more profitable to the farmers, he does something which will help his own business, because there is not in the United States any business centre that could continue to prosper independently of the farming communities surrounding it."—Edwin T. Meredith, U.S. Secretary of Agriculture.



# What About Auto and Implement Prices?

Before There Can be Any Drop in Implement Prices or Further Drop in Car Prices, Production Costs Must be Reduced. Implement Prices Expected to Remain Stationary

**N**OTWITHSTANDING statements to the contrary by different large concerns manufacturing automobiles and farm machinery, the public has conceived the idea that present prices of these lines will drop considerably in the near future, many expecting the drop will be to a pre-war basis.

Although prices of staple commodities and everyday necessities are generally supposed to be on the decline, there can be no appreciable drop in these two lines, the reason being that those commodities which have shown a decline in price to the consumer are articles which are not materially affected by manufacturing processes.

## Raw Material Costs

Three things enter principally into the production and offering for sale of the lines in question, they being the market for raw material, manufacturing costs and distribution costs. Dealing with the first, we find that we are living in an age of mechanical efficiency, when the production of ore must be at its highest in order to supply the demand for the manufacture of machinery, etc., for use in peaceable pursuits. We find in this connection that working hours have been reduced and in spite of the increased numbers employed that the supply is falling far short of the demand. Couple with this the fact that although ore production was trebled during the last six years, during which most nations were engaged in strife—the market went sky-high—because not sufficient raw material was being mined. To-day the demand is so great that mills can get almost any prices they like to ask, and if our home manufacturers do not pay it, and in cash, too, the mills sell to factories in foreign countries, where they find a ready cash market at practically any price. This condition, plus the present exchange values, makes it good business for enterprising mill owners and manufacturers to place their output on foreign markets.

## Manufacturing Costs

Dealing with manufacturing costs, we have to say that labor will not stand for an immediate reduction in wages, which can easily be understood with the present inflated prices of necessities. Prices went up first and labor eventually came into its own, now labor awaits the return of prices to as nearly normal as possible before considering a reduction in wages—and no one blames them. Labor represents nearly 75 per cent. of the manufacturer's costs of producing automobiles and farm equipment. Then fuel has aligned itself with everything else, and stays on the "higher plane." Executive and clerical help salaries are considerably advanced, although not quite so

By H. T. PIZZEY

SEC. IMPLEMENT AND AUTO TRADE SECTIONS, SASK. R.M.A.

of raw material and the laid-down price of the manufactured article. Numerous 2 per cent. sales taxes have to be paid, and a 15 per cent. excise tax on automobiles.

## Show Reduced Profits

Contrary to the reports which are emanating from Government commissions of the United States that the present profits of implement manufacturers and retailers are too high, these concerns show greatly reduced profits, and this in view of a largely increased volume of business, most of which, however, may be accounted for to a great extent by increased prices.

In Western Canada, where the retail implement dealers were allowed a gross margin of between 20 per cent. and 25 per cent. in 1914, they now have to thrive (?) on a margin which ranges between 8 per cent. and 16 per cent., and this against greatly increased overhead expense, yet the public are willing to believe that the retailer is responsible to a great extent for to-day's prices.

Even though the cost of raw material returns to its normal basis tomorrow, it would be at least six and probably nine months before this would have any effect on prices, as the product of this material would not be on the market until at least that time had elapsed.

Again, the action of the farmers in holding their grain for higher prices has its effect on prices. The farmer owes the dealer, who, in turn, owes the job-

ber. The jobber owes the manufacturer, and because no money is forthcoming he in turn cannot pay cash for his raw material, and then the mills and manufacturers sell to foreign markets, where the cash is forthcoming in spite of chaotic conditions there. The fact that the public and the farmers are withholding from buying automobiles and farm equipment cannot possibly have the effect which they conceive it must have. It will just result in the closing of factories, which means additions to the already large numbers

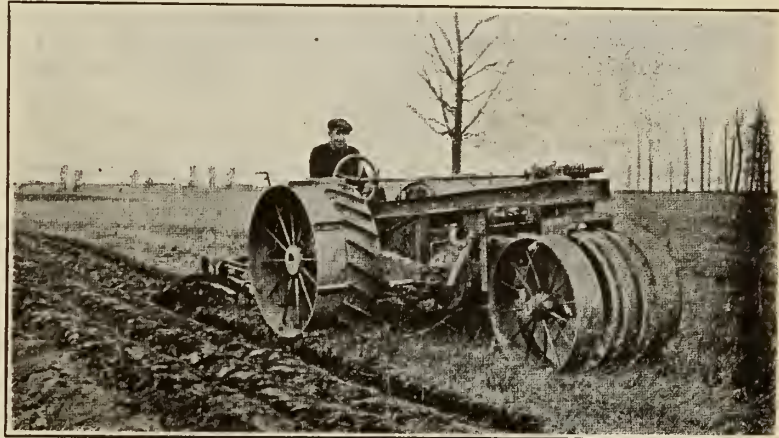

With a tractor the farmer need not worry about the weather. He can do his fall plowing when horses would be held up.

of unemployed, or at least the placing of labor so employed on half-time basis. One has only to read the newspaper reports to learn that this is just what is happening.

These are just a few reasons why prices of manufactured articles must remain practically as they are for some time to come, and a review of these facts will result in any fair-minded man coming to an understanding with himself accordingly.

## Motor Truck and Team Compared

By W. A. CARPENTER, Acme Motor Truck Co.

**W**HILE very much has been said upon this subject, the following comparison will illustrate in a striking way the difference between the two methods, and may present the matter in a different light than you have seen it before.

The average two-horse team will haul two tons over the average road at a speed not greater than three miles per hour. Allowing one hour for the noonday stop, and another hour for loading, unloading, resting on grades and miscellaneous delays, it is safe to say that the team will, in a ten hour day, cover not more than 24 miles. But at least one hour in the early morning before starting on the trip, preferably longer, must be allowed for the horses to be fed, curried, harnessed and watered, also part of the noon hour must be devoted to care of the horses and at night after working hours, some little time must be devoted to feeding, watering, bedding and currying them. All of this extra work must be done outside of the ten working hours, to say nothing of veterinary services. So much for the horse hauling method. Now for the truck's side: No preliminary work in the morning is necessary, with the exception of a few moments' inspection every morning, desirable in any piece of

24 miles). At the close of 300 days, truck will be 40,800 miles from the starting point, though during the 300 days the team has covered only 7,200 miles. In other words, the truck has carried two tons 33,600 miles further than the team did in the same length of time. Keep this up for say five years, if the horses are able to work steadily 300 days per year for five years, and we find the truck 168,000 miles ahead of the team. Counting feed, care and upkeep of team, harness and wagon, the cost of operation and maintenance is about the same for truck as for team, at least not much more.

Hence there can be no argument concerning the efficiency of the two methods of hauling. The investment, of course, is much greater with the truck than with team, but as will be seen from above, the results do not compare favorably to the horse.

## Western Automotive Equipment Show

**A**N organization has been formed which will assure for Western Canada an automotive equipment show. The officials have secured the Board of Trade buildings for the last week in the Winnipeg Bonspiel—February 14-19. As there are about 4,000 dealers in the three Western provinces, Manitoba, Saskatchewan and Alberta, handling automotive equipment it is easily seen that such a show—where dealers can get together to compare ideas and see the latest equipment in their lines on exhibit—will be of considerable advantage to the trade. Experts from a great number of different manufacturers will be on hand to explain how best to handle their lines.



A tractor sale also means the sale of a belt-power machine to go with the tractor. Illustration shows a tractor operating ensilage cutter and silo filler.

much as in the case of labor. Expenses of travelling experts and salesmen has doubled, and no reduction of staff can be made here, as competition and public demand for service necessitates a big expenditure in this connection. Freight rates have gone up nearly 70 per cent. since 1914, thereby adding to the cost

machinery. Allow the same two hours' lost time each day for truck as allowed for team, (though the hour allowed for such delays will be confined to loading and the greater part of this time eliminated. At the close of the first day the truck will be 136 miles from place of starting (remember the team has made but



# Cashing In on Tractor Overhauling

The Live Dealer Has an Excellent Opportunity Now to Profit by Winter Overhaul.  
The Time to do Tractor Overhauling is in the Slack Winter Season, When the  
Job Can be Handled Leisurely and Thoroughly

"IN times of peace prepare for war," and in the slack season prepare for the busy one.

Overhauling a properly designed tractor, that is, one which was designed with the accessibility feature in mind, is not a particularly difficult task. However, it is not a job which one wants to be compelled to tackle when conditions are just right for spring plowing and the season is late, or when seeding should be going on and the seed bed has not been completed. Nor does one want to stop in the harvest season to overhaul a tractor, or any other machine for that matter—the time to do tractor overhauling is in the slack winter season, when the job can be handled leisurely and thoroughly.

Farmers are becoming much better acquainted with tractors than they were a few years ago. A great many owners are now capable of overhauling their own machines and doing a first-class job in almost all details. Others, however, require the assistance of a good mechanic, and the live tractor dealer will take advantage of this fact, for he can not only turn it to his own advantage, but to that of his customer.

Most every farmer will recognize the desirability of having the tractor gone over carefully during the slack season to make sure that all bearings are in good shape and that badly worn or broken parts are replaced. Even if nothing more is necessary than to remove gummed oil and dirt from the working parts the job will be well worth while, as these are pretty sure to cause delays if neglected, and such delays are almost certain to be encountered when the tractor is badly needed.

## Dealer's Service to the Farmer

But while the tractor owner may recognize the desirability of such overhauling, if it is suggested to him, he is quite likely, if left to himself, to put it off because he is a little afraid to tackle the job. There is a good opportunity, therefore, for the dealer to render a service to the farmer, either by giving him a little personal help or furnishing a mechanic who can assist him in going over the tractor, cleaning up all working parts and making such adjustments and repairs as are required.

The question of charging for this sort of service is one which must be decided by the dealer. Some dealers perform this kind of service for a year or two without charge, while others believe that it should in all cases be paid for. Regardless of the matter of reimbursement, however, most tractor owners are likely to appreciate a little advice and assistance along

By **ARNOLD P. YERKES**

this line, and the dealer is taking a long step toward making such overhauled tractors prove more satisfactory to their owners than would be the case if they were neglected until the busy season was on.

## Overhauling Leads to Sale of Parts

There is more involved in tractor overhauling than just the work required—often it proves quite profitable because of the sales of parts which result.

In overhauling a tractor which has been used for several seasons, it will nearly always be found that there are some parts which should be replaced because of wear or damage. If the work is done during the winter there is no particular rush about obtaining the new parts, and if it is necessary to send to the manufacturer's branch house or to the factory for them the farmer is not going to be so vexed as he is likely to be if such parts must be ordered during the rush season, perhaps incurring the unnecessary expense of telegrams and express charges.

There are also likely to be cases where the dealer can foresee that certain parts will be needed for tractors which he has sold and can take steps to get them in stock if they are not already on hand. Oftentimes a tractor owner is rather inclined to allow a worn part to remain on the machine until it is absolutely necessary to replace it. This necessity may arise when the tractor is badly needed, and if the dealer does not have such part in stock there is always the possible chance of an aggrieved customer. If the tractor dealer or his assistant helps with a job of overhauling they can make note of such parts as they feel will be needed and can quietly order same so as to be sure to have them on hand when called for.

The season of the year when farmers have least to do is also usually a slack season with the dealer, and if advantage is taken of the opportunity offered in the overhauling of tractors already sold and selling the necessary spare parts and attachments for them, the time will be well spent, both from the standpoint of the dealer and of the farmer.

In carrying on the work of overhauling tractors in the hands of farmers there is also always an excellent opportunity to sell attachments and accessories, the profits from which may amount to quite a neat sum. Oftentimes a farmer will be willing to buy some attachment for his tractor and put it on during the slack season, when he would not waste time on

it during the summer. The possibilities in this line should not be overlooked. Self-steering devices, lighting outfits, special hitches, etc., should be suggested and sold if possible.

## Tractor Inspection

If the dealer does not care to have someone help do the work of overhauling he can often be of considerable assistance in suggesting and advising the tractor owner or whoever is to do the work. The



Testing connecting-rod bearings for looseness by holding gears on bearing and rocking the fly-wheel.

dealer should be sufficiently familiar with the tractor which he sells to be able to make a short inspection of the machine and advise the owner pretty definitely what should be done with it. For such inspection it will be well to arrange and follow a uniform system, so as to be sure that no points are overlooked and in order to avoid loss of time in making such inspection. The method of inspection to be followed will, of course, vary with different makes of machines, and on some there will be certain points to look for which will not be present on others. With a little practice a man can look over a tractor in just a few minutes and be able to tell most of the things which will need attention. For instance, the compression can be tested in order to ascertain if the valves are leaking. On some tractors the main bearings can be tested for looseness in a moment's time by means of a short lever properly placed. The timing of valves and spark can also be checked very quickly by an experienced man. Then there are less important details such as the adjustment of the front wheels, looseness of their bearings, tension of the drive chains, if the machine is a chain drive, and other points which should be given attention.

## Making Friends Through Repair Service

If the dealer has a shop fitted out for doing repair work it may be found most satisfactory to have the owners bring their machines in for such inspection and have the work done in the shop. In the slack season there is not the objection to driving the tractor to a shop as during rush seasons. With a tractor which has been designed with the accessibility feature in mind, however, practically all the work of overhauling can be done just as well on the farm as within the shop.

To sum up the matter, every tractor which has been used a full season should be carefully inspected and overhauled before it is put in the field for next year's work, and there is an excellent opportunity for the live dealer to cash in on this overhauling business and at the same time to make better friends of the tractor owners in his territory.



Overhauling of tractors should be a profitable business for the dealer during the winter months.



# Just a Few Points About Selling Trucks



## Truck Prospects are Found in Practically Every Business and on Every Farm. Importance of Winter Selling Should Not be Overlooked

**T**HREE years ago motor truck salesmen used to worry about who were prospects and who were not.

There is no such difficulty to-day.

Every man who uses a horse and wagon to carry his goods, no matter what they are or where they are going, is a truck prospect. Yes, and there are others. Every company which transports its commodities by rail or steamship is a prospect, provided that the goods are not too light and bulky and do not have to be carried over 150 or 200 miles. Lastly, every man who actually owns and operates a truck is a prospect. He either needs more trucks to-day or may need them in the near future. No matter even if he owns other makes than your own. As long as you are confident that your truck can give better transportation service than that of any other maker, go ahead and sell him one or more of your trucks. If you haven't got this confidence, then you've no business to be in the game at all.

Do the truck dealers and salesmen of Canada fully realize this present situation? It means that almost every class of manufacturer, farmer, dealer and store owner in Canada needs motor trucks to relieve him of most of his transportation worries.

The day of experimentation is over. The era of motor truck transportation has definitely arrived.

It is only recently that it became an accepted fact that Canadian industry and Canadian business needed motor transportation. Notice to-day a few of the industries using this new agency—iron and steel, lumber, oil, milling and textile; and just a few of the manufacturers—clothing, barrel, bottle, furniture, machinery, biscuit, soap, glass and basket. And then there are the contractors, the ice and coal dealers, the department and small store owners, the laundrymen, the municipal authorities, the express companies and countless others. Last, but by no means least, there are the farmers—every class of them.

### Finding Prospects

Surely there is no question to-day as to who are prospects and who are not. And how are these prospects found? They are found chiefly by close observation. A complete prospect list of your own territory is, of course, not only helpful, but a vital necessity.

No sales campaign should ever be started without definite information regarding a long list of prospects. Newspaper and magazine advertising, sales letters and personal interviews should all dovetail.

But sudden bursts of rapid fire selling campaigns are not the only way to show big sales year after year. It is "close observation" of the activities of a city or town that gives a truck salesman most of his "clues." "I saw an excavation cluttered up with horses and wagons this summer," explained a salesman, by way of illustration. "The horses were sweating as they dragged wagons loaded with dirt and building supplies. We interested the contractor in truck transportation, turned three of my trucks onto the job, proved my case—and now, that firm of contractors is using nine of our trucks." It is exactly the same in the case of the dealer and salesman who concentrate their attention on sales to farmers. The homes of the farmers of the territory must be secured

By **ELTON JOHNSON**

and in addition accurate information regarding the class of farming undertaken, the markets served and the possibility for each of widening the market area.

### Not Trucks, But Transportation

And now—the actual selling. It sounds absurd—but here it is—"Don't sell motor trucks."

The present-day, reputable salesman is selling motor truck transportation and not motor trucks. He doesn't sell his prospect on the fine appearance of his truck or on the price of it. He proves to the interested party that a motor truck or motor trucks, regardless of original investment, would reduce his transportation costs. He does this by working out transportation costs on the ton-mile basis, boiling down every conceivable cost to this one unit. The cost per ton-mile of truck, horse and wagon, steamship and railway freight cars are all compared and an accurate result is obtained. The reputable salesman refuses to sell a man a truck whenever it is proved that the cost per ton-mile is less by some agent of transportation other than trucks.

Once the prospect is shown by special figures that trucks will reduce his transportation costs—which, by the way, comprise a greater percentage of total costs than most people imagine—then, the truck salesman naturally points out that this saving is worked out on figures obtained from actual experience of owners of his own particular make of truck. He points out that the original cost of the truck is only an investment—that the actual cost is determined by the number of years of faithful service the truck will give.

The salesman must prove that his truck will give efficient transportation. Inefficient transportation is dear at any price.

The biggest mistake that a truck concern can make is to consider the sale of a motor truck the end of the bargain. The relation of the company to the buyer has only just begun and a close co-operation must be kept up throughout all the time that the purchaser is using the truck.

The service sales department is of the utmost importance. Upon it depend future re-sales and also the reputation of the dealer. And reputation cannot be bought. It must be built up gradually and systematically.

A truck dealer must be prepared five years after the sale of a truck to answer the appeal of the original purchaser and investigate his transportation requirements. It will cost the dealer money to keep in constant touch with his customers, but it is money well spent and will pay increasingly large dividends throughout the years.

It often happens that a truck salesman cannot prove that a truck would be a paying proposition for a single farmer. It is then up to him to interest three or four farmers in the idea of a community truck. The community truck could carry into the city markets the produce of a number of farmers and carry back at the end of the day those articles purchasable only in the city and needed by the farmers themselves

and by small town store owners. Here is a big field for the truck salesman, and only the fringe of it has been touched as yet.

### The Price Situation

To-day, the general slump in all trade has naturally affected the truck dealer. He is finding that people are holding back, waiting for prices to drop. The truck salesman must find out the actual situation with respect to his company's truck prices. And he will find out that the situation is not hopeless. Trucks can be sold to-day and here's why.

If truck transportation is ever valuable, then it is more so at this moment than ever before. Steamships are held up in dock for the winter. Freight cars are being congested with heavy winter traffic. There has been little profiteering in truck selling. If the price of a truck hasn't been abnormally high during the past two or three years, then it isn't going to come down now. For the cost of raw materials is staying up and labor is receiving the same pay.

### Why Not Sell This Winter?

Why should the majority of truck dealers and salesmen sit down with folded hands throughout the winter? Trucks can be sold in winter. Some progressive companies are doing it. There is no reason why all should not.

In the first place, trucks must be sold on their ability to deliver transportation with efficiency and economy in winter. Comfort for the driver must not be overlooked as a selling argument, and this necessitates special winter equipment on the truck. Maximum sales effort in winter should be directed towards those businesses that are most active during the winter months. The attempt must be sincerely made to carry on throughout the winter a vigorous sales campaign directed towards all classes of prospects.

Frankly, it is difficult to-day on account of the still inadequate road system to sell trucks to farmers in winter. There is no reason, however, why propaganda could not be carried on with the farmers so that a salesman might be ready to take actual orders when spring first sets in.

It is on "service" chiefly that a truck can be sold in winter. Advertising, sales letters and salesmen's calls should all emphasize the fact that your trucks can stand up under winter weather and that your service policy will see that they are kept running all winter at maximum efficiency.

Winter sales must be timely. Misdirected effort is worse than useless.

### A New Automobile for Canada

**A**RRANGEMENTS are reported to have been made by John D. Siddeley for the manufacture of Armstrong-Siddeley automobiles in Canada. Mr. Siddeley represents the company and was recently in Canada making arrangements with the Canadian company, the Armstrong-Siddeley Company of Canada, Ltd., 298 St. James Street, Montreal, to manufacture these cars and to distribute them in Canada. The car will be a high-grade one and will command a substantial price.



# CANADIAN MOTOR, TRACTOR AND IMPLEMENT TRADE JOURNAL

Published on the fifth of each month by

The MacLean Publishing Co., Limited  
TORONTO, MONTREAL, WINNIPEG

JOHN BAYNE MACLEAN, President. H. T. HUNTER, Vice-President.

H. V. TYRRELL, General Manager.

LONDON, ENG., THE MACLEAN COMPANY, OF GREAT BRITAIN, LTD., 88 FLEET STREET, E.C.

BRANCH OFFICES: Montreal, Southam Building, 128 Bleury Street; Winnipeg, 1103 Union Trust Building; Vancouver, 314 Carter-Cotton Bldg., 198 Hastings St. W.; New York, Room 620, 1133 Broadway; Chicago, 405-6 Transportation Bldg.; Boston, 734 Old South Building.

SUBSCRIPTION PRICE—\$2.00 A YEAR.

OFFICE OF PUBLICATION—143-153 University Ave., Toronto.

Vol. 2 TORONTO, DECEMBER, 1920 No. 12

## The General Situation

THE general feeling in banking circles and among automotive distributors and dealers is that the money market is getting easier and signs are not lacking that the public has commenced to buy. No further reductions in prices of automobiles and automotive equipment are expected in the immediate future.

The gloom which settled on the whole automotive industry two months ago is gradually being dispelled and giving way to an optimism which will go a long way to rouse the buying public from its inertia and restore sales to a normal basis by the spring. The public is refraining from buying, not so much from lack of money as from an expectation of still lower prices. Anything the manufacturers, distributors and dealers can do to correct this notion should be put into effect at once. Reviewing the general conditions which prevail at present the Commerce Monthly has this to say:

The determining factor in the entire situation continues to be the reluctance of consumers to buy, partly because of their expectation that prices may go even lower, and in part because of the curtailment of purchasing power of large sections of the buying public. Farmers are not purchasing actively at present because prices of the products which they have to offer in exchange have declined sharply. Wage earners hesitate to purchase because their earnings are being curtailed by increasing unemployment and in some cases by reduction in wages.

The adjustment of prices to new conditions of supply and demand has proved difficult.

Two factors on the buying side of the equation offer much encouragement, however. In comparison with those classes whose income increased rapidly during the period of rising prices, the decline in prices which has already taken place has increased the purchasing power of salaried employes and persons in receipt of fixed incomes from investments. Large crops assure a fair volume of buying throughout the agricultural parts of the country, especially the grain states. Farmers unquestionably are delaying their purchases until the prices of what they must buy approach the level at which they must sell their crops. As that level is approached they will buy in increasing volume, because their position is essentially sound.

In direct contrast to the trend of most commodities the prices of tractors and farm machinery show no downward tendency. On the contrary, many tractor manufacturers have announced increases. Whether the industry will be able to maintain these new price levels is matter for speculation, but the situation shows that the power farming industry is in a healthy condition.

There has been a big demand for farm machinery during 1920, and in many cases the supply has been inadequate to meet that demand. During November the demand for tractors slowed up considerably owing to the early and heavy snowfalls in nearly all parts of the country, resulting in the fall plowing being



London "Punch."  
Welsh Wizard: "I now proceed to cut this map into two parts and place them in the hat. After a suitable interval they will be found to have come together of their own accord—(aside)—at least let's hope so; I've never done this trick before."

held up somewhat. However, the indications are that there will be big tractor sales in the spring. Distributors and dealers report that enquiries are coming in fast in regard to tractors and farm machinery and are laying their plans for a big spring business.

## Does This Mean You?

THERE is a type of dealer to-day—in fact he has always been with us—who, in a period of depression, shakes his head sadly and intimates to the world at large that business is going to the "bow-wows." After making this statement he retires to his sick store and gives himself up to gloomy reflections—when he is not cursing the Government.

It would be hard, even in a period of prosperity, to find this type of dealer when he has not a grouch on. He sits in his store complaining about bad business and it never enters his head to get out of his chair and go and find customers. The successful implement and automobile dealers are those who are out among their prospects all the time discussing their problems and trying to show them where these problems may be eliminated by the use of modern equipment.

Then, again, the successful dealer has a store that one can get into without having to step over articles littered all over the floor. His windows are kept clean and used for other purposes than to display long out-of-date advertisements of the "Clutching Hand," etc. The glass is washed regularly and articles for sale are displayed in an interesting man-

## PRINCIPAL CONTENTS

Are You a Power Farming Specialist?.....	5
Success by Helping the Other Fellow.....	6
What About Auto and Implement Prices?..	7
Motor Truck and Team Compared.....	7
Cashing-In on Tractor Overhauling .....	8
Just a Few Points About Selling Trucks...	9
Editorial Page .....	10
Importance of Selling Proper Tire Equipment .....	11
Saskatchewan Dealers Benefit by Organization .....	12
Shop Layout to Facilitate Battery Work...	13
Giving Farm Machinery a Fair Chance....	14
How Auto Prices Are Affecting the West..	15
Selling the Prospect Who Has to Be Shown	16
Shop Notes for the Garage Man .....	18
Automotive Accessories .....	22, 24, 26, 30
"Electrion"—a New Farm Lighting Plant..	34
Dairy and Household Supplies .....	36
Making a Football of the Hydro .....	40

ner. The passer-by at once gets the impression that the dealer is alive and on to his business. He knows, too, that should he go in to discuss business matters there are a few chairs handy and an orderly office where he can sit and talk in comfort. The condition of some dealers' places of business is a disgrace to the industry to which they belong.

It is remarked, too, how some dealers, even in good territories, meet with comparatively poor results, while other dealers in much poorer territories do a very big business.

It all simmers down to the individual. If a man would succeed in the implement and automobile business he must attend to the fundamental principles, namely, orderliness, punctuality, honest dealing, and the capacity for hard work.

## No Room For Pessimists

MANY of our thoughtful citizens have realized for some time past that there was danger ahead and urged Canadians to get down to earth and get to real work, says Lloyd Harris, prominent industrial executive and head of Canada's Trade Mission to Europe, in The Financial Post. The majority of people, however, do not realize the imminence of a danger until they are actually face to face with it.

There had to come a deflation period and it is here and we have to meet it. It will be hard for the country for a time, but if it will give everybody a sense of proper proportions, it will be the best thing that can happen to Canada and we will weather the actual after-the-war readjustment period with great benefit to our people and to our country.

Canada has a great future with proper leadership at the top and good common sense in her people.

We must get a proper balance of things. The people must realize that they must work out their own problems in agriculture, commerce and industry and not expect or ask the Government to do things they should be doing for themselves, and the Government should confine itself strictly to the duties of Government. Evidently great statesmen in the past had problems similar to those we have to-day, as Lord Macaulay, one of England's greatest statesmen, in 1830, expressed his opinion as follows:

"Our rulers will best promote the improvement of the nation by strictly confining themselves to their own legitimate duties, by leaving capital to find its most lucrative course, commodities their fair price, industry and intelligence their natural reward, idleness and folly their natural punishment, by maintaining peace, by defending property, by diminishing the price of law, and by observing strict economy in every department of the State. Let the Government do this; the People will assuredly do the rest."

It would appear to me that this meets our present situation. There is no place in Canada for pessimists as we have the greatest heritage of any nation in the world and we must have vision and courage in attacking and working out our problems.

Our natural resources, the value of which so much is talked about, are of no value unless developed and exploited, our surplus agricultural products must have markets for their disposal, our industries must be expanded by finding export markets so as to give them quantity production, and thus lessen the cost of production, our educational system must be improved so that our people will have a broader outlook and our standard of living must be maintained. In working out these problems the people have much to do and the Government has its full share of responsibility and the two forces must pull together, each doing its full share, acting together in complete co-operation.

The big holiday is over and we must now get down to earnest effort and hard work, and I am quite sure that our Canadian people will, with our resourcefulness and ability, meet the situation with courage, confidence and success.

## Hart-Parr to Guarantee Prices

THE Hart-Parr Co., Charles City, Ia., has advised its dealers that the present price of the Hart-Parr 30 will be guaranteed to dealers and customers until June 1, 1921. In the event of any reduction being made prior to that time the amount of the reduction will be refunded dealers and customers. The company points out in its announcement that the present price of its tractor represents but little increase over pre-war prices.



The truck dealer and truck tire dealer by giving special attention to the proper tire equipment for trucks will go a long way to making truck owners satisfied with their machines.

When tires are used which are not the most suitable for the work in which the truck is engaged, not only do tire expenses become excessive, but the motor and chassis soon show the effect of strain and vibration. It does not take the owner long under these circumstances to make up his mind and tell other interested persons that he would rather have purchased a different make of truck from another dealer.

# The Importance of Selling Proper Tire Equipment

By DONALD R. COWAN, M.A.

points in both the mechanical and economical operation of pneumatic and solid tires.

### Reasons for Premature Wear of Pneumatics

Pneumatic and solid tires differ in many respects. Pneumatic tires may wear out prematurely and a number of important reasons for doing so may be summarized:—

1. Under-inflation.
2. Overloading.
3. Excessive air pressure.
4. Speeding around corners.
5. Excessive speed.
6. The locking of brakes.
7. Misalignment of wheels and trailing fenders.
8. Lack of attention to cuts, bruises, and blisters.
9. The rotting of the rubber by oil, grease and sunlight.

Under-inflation and excessive air pressure do not apply to solid tires. Probably the most harm can be done to them by overloading. The rubber will become stretched beyond its tensible strength and will not contract to its former position. In this respect the solid tire differs from the pneumatic tire. The latter will withstand overloading for a limited period, but the former will probably be ruined by one overload. Usually the manufacturers of high-grade tires recommend that according to the size of the tire the load upon it should not exceed a certain weight. It is often the case that while the truck itself is not overloaded, the load may be so situated that one pair of the wheels carries more than their burden. The load should be evenly distributed upon the truck.

Experiments have shown that it is economical to remove a solid tire when it is worn within one inch of the rim of the wheel. Beyond that point the vibration of the truck will be excessive and therefore repair costs will likely be high.

### Economies of Pneumatics and Solids Compared

The economies of pneumatic and solid tires might now be compared. For this purpose one company kept the cost of rising pneumatic cord tires and solid tires for six months. Two trucks of the same make and size were used for the experiment. The first truck was equipped in front with pneumatic tires and in rear with solid tires, while the second was equipped entirely with pneumatic tires. The results may be summarized as follows:—

	Solid	Pneumatic	Pneumatic
Miles travelled	4800	6000	Saving by
Truck repair costs	\$129.55	\$63.09	\$ 66.46
Gasoline (at 35c)	1812 gal.	1320 gal.	172.20
Oil used (at 25c)	504 qts.	360 qts.	36.00
Depreciation	3c per mile	1c per mile	84.00
Wages covers 25 per cent. more miles with pneumatic			161.50
Total			\$520.16

Between May 24th and July 9th two 2-ton trucks belonging to a large company were sent on a tour of country points in the West. One truck was equipped with solid tires, the other with pneumatics. Operating together over the same roads and under practically the same conditions they covered approximately 3,000 miles. The results in favor of the truck equipped with pneumatic tires were:—

1. 30 per cent. more mileage per gallon gasoline.

2. 16 per cent. more mileage per gallon oil.
3. 77 hours less time spent on repairs.

In detail their consumption of gasoline and oil was as follows:

Equipment	Mileage	Gals. gas.	Miles to gal.	Gals. Oil	Miles to gal.
Pneumatic	3017	408	7.4	52	58.5
Solid	2997	522	3.7	59	50.5

Although allowance should be made in both illustrations for varying efficiency of factors other than tires it would appear that under suitable conditions the pneumatic tire is very economical. The most important questions arising in connection with the use of pneumatic tires are probably these:—

1. On what size truck can they be used?
2. In what class of service?
3. On what kind of roads?
4. What advantages are obtained?
5. What disadvantages become evident?
6. Will it be necessary to radically modify truck construction to use pneumatic tires most economically?

### Where Pneumatic Are More Economical

For 2-ton and 2½-ton trucks hauling fragile freight with frequent stops the pneumatic tire is more economical. Examples: Are the delivery of foodstuffs and rural express for marketing farm products. Pneumatic tires are used on large sized trucks for long hauls when speed is required. When hauls are of normal length more can be gained, as a rule, by speeding up the terminal handling than the truck on the road. A limiting factor in all cases is to be found in the character of the roads on which pneumatic equipment is operated.

The advantages of the pneumatic tire are numerous:—

1. Reduction in mechanical repairs.
2. Increase in permissible speed.
3. Decrease in gasoline consumption.
4. Decrease in oil consumption.
5. Less vibration and therefore less fatigue for the driver and slower depreciation of the truck.
6. Lessened depreciation of the roads.
7. Greater tractive ability.

The disadvantages may be summarized as follows:—

1. High initial cost compared with solid tires.
2. The need of carrying emergency equipment.
3. The difficulty of changing tires on the road because of weight of load and high inflation requirements of pneumatic truck tires.
4. Reduction of the high gear ability and limitation of the total ability because of the greater diameter of the wheels.
5. Limitations imposed on the size of brakes due to the small size of wheels.

### Bonus for Ford Employees

BONUS checks aggregating more than \$7,000,000 for employees of the Ford Motor Car Company are now being written, and their distribution will start on January 1 next, according to announcement recently by E. B. Ford, president of the Ford Motor Company.

Mr. Ford also announced a forthcoming extra three per cent. for the six months ending on December 31 on Ford investment certificates held by employees of the company. This is in addition to the guaranteed six per cent. Eight per cent. had been paid in July last, making a total of 14 per cent. on the certificates for 1920.

TO both the dealer and the customer no part of original truck equipment is more important than the character of the tires. The cost of maintaining truck tires when interest upon their first cost, depreciation, and repairs are all considered is frequently as large an item in the operating expenses of a truck as the driver's wages. If tire costs are unduly large the new owner will lay the blame upon the dealer who sold the truck to him. When tires are used which are not the most suitable for the work in which the truck is engaged, not only do tire expenses become excessive, but the motor and chassis soon show the effect of strain and vibration. Under these circumstances it does not take the owner long to make up his mind and tell other interested persons that he would rather have purchased a different make of truck from another dealer.

Now, so far as quality is to be considered, both the truck and its tires may have been made of the best material. The real reason for the extra expense borne by the owner and his consequent dissatisfaction may be traced to the dealer who sold the truck without giving sufficient attention to the service in which it was to be engaged, the kind of highways over which it was to operate, and the care which the purchaser was likely to give it.

Possibly the dealer should have sold the truck with over-size tires in order to allow for the purchaser's habit of overloading. Perhaps he should have sold pneumatic tires instead of solid tires in order to allow for the speed required for either a fast freight service or the satisfaction of a reckless driver's desires. Or perhaps expensive pneumatic tires were unnecessary and solid tires would have given most economical service when everything had been considered. It is simply the old truth brought home to the dealer that prevention is better than cure. Every business man is a fortune teller, and his success in business is often the measure of his ability to foretell or anticipate the desires or complaints of the consuming public. The dealer in motor trucks is no exception to this rule. He should carefully study his prospective customer and the class and conditions of business in which he is engaged. If he can anticipate trouble arising from the sale of certain tire equipments he should sell other equipment which will suit the circumstances, or he should not sell tires at all. The dealer in motor trucks who can accurately foresee these contingencies will have many satisfied customers and profits which are both large and permanent.

If the dealer intends to sell the proper tire equipment to a particular customer he must know the vital



# Sask. Dealers Benefit by Organization

The Organized Auto and Implement Dealers of Saskatchewan Have Won the Attention of the Government and Manufacturer Alike, and are in a Fair Way to Have Trade Wrongs Adjusted



**N**OWADAYS individual play in business leads nowhere. It is the combination work that makes the tallies. Protective and, one may say, predatory, organizations are springing up everywhere, so that any trade which hopes to keep its end up is driven to meet organization with organization.

That is only the first step. The next is affiliation, the pooling of interests with those trades nearest in sympathy. Labor with labor; retailer with retailer.

## Organization Needed

The implement dealer needs organization in a special way. Not only has he to meet the encroachments of the manufacturer on his constantly decreasing profit margins—such as they are—but he has to look out for inroads from the consumer side, the farmer organizations which are extending further and further into the retailing field in pursuit of the farmer's millenium, reinforced by protective legislation, which, if not keenly watched, is likely to add greatly to his already too heavy disabilities.

In Saskatchewan the first step towards organization was taken when the old Saskatchewan Retail Implement Association was formed; the second when this body merged with the Retail Merchants' Association in 1918. Still very little progress could be made until the necessity for special treatment was recognized all round. The Implement Trade Section Executive was composed of five of the most active and far-seeing men in the province—all busy men. They could initiate reforms which would place the trade up where it belonged, but none of them had the time to devote to the work. The one thing necessary was to get a man who would confine his attention to carrying out the special work needed.

Early last spring an offensive and defensive alliance was made between the executives of the automobile and the implement trade sections, and through the instrumentality of F. E. Raymond, provincial secretary of the R. M. A., Harry T. Pizzezy was appointed secretary to the Joint Trade Sections, and was to devote his energies wholly to the needs of those two bodies.

That was nine months ago. Notice the results up to date.

1. The moral weight of the whole retail trade in Saskatchewan added to the importunities of these two bodies has won the attention of the Government and the manufacturer alike, and the old "we-will-talk-to-you-when-you-come-with-a-big-enough-club" attitude of the manufacturers has gone where the good niggers go.

2. The facts and figures regarding the margins allowed to the retailer, collected and collated by the secretary and presented with insistence where they would do most good, have driven the implement manu-

facturers to a defensive position—which is a long step towards a fair settlement of the margin question.

The real service which the members of the R.M.A. are getting from the provincial office has energized the dry bones of the old organization to such an extent that implement and automobile men are just flocking into line. During the past nine months the membership of those two trade sections alone has increased 200 per cent., and,

3. What is by no means the least important result: automobile and implement organizations are springing into life and activity in nearly every province in Canada under the impetus—plus publicity—of the Saskatchewan movement.

Now, to develop these points a little. Probably every automobile man in Canada knows what the Saskatchewan Automobile Repairs Act is. It was passed at the last session of the Provincial House for the purpose of protecting the car-riding public in a way similar to that in which farmers are protected under the Farm Implement Act. Auto dealers in Saskatchewan were placed under the obligation of carrying all necessary replacement parts and repairs for all cars sold by him for a period of five years after the date of the sale.

This bill was rushed through the House before the trade had an opportunity to digest it and make proper representations against it, and in its headlong dash the burden of carrying the repairs was somehow transferred from the shoulders of the manufacturers to those of the retailer, and he was saddled with the obligation of having to stock parts amounting to anywhere from \$500 to \$5,000, depending on

the make of car, all the year round for every single automobile sold by him.

It is an ill wind that blows no one any good, and this act was the prime cause which drove the auto men of Saskatchewan into the arms of the R. M. A. She promptly covered them with her motherly apron and went to work. It is unfortunate that the results of her labors cannot yet be made public, but before the present session is over the word of the Premier has been given that the auto men will be freed, in one way or another, of the heaviest burdens of the act.

## Farm Implement Act

With regard to the Farm Implement Act there are a number of improvements which the association has recommended to the Government, and which the Government has under consideration, the most important of which is that the act should be amended to provide for a uniform contract which will allow to the retailer the same warranties from the manufacturer as he is bound to concede to the purchaser.

The moral support of the R. M. A. is already having the effect of wooing the implement manufacturers to an attitude approximating sweet reasonableness towards the retailer. The constant dropping of water will wear away the hardest stone, and, acting with a persistency based on this simple saw, the trade section secretary has at last worn through the armour-plated deafness (pretty good for a mixed metaphor), of the manufacturer until, at last, he is beginning to hear some of the talk about the smallness of the margins he allows the retail dealer. In one case assurance has been given that when next year's contracts are issued this injustice will be made right.

One of the most effective weapons used to bring about this new attitude has been the array of statistics prepared by the secretary showing the fluctuation of margins on twenty-five lines of farm machinery over a period of ten years. These figures yield the fact that while the costs of machinery, carrying charges, and so forth, have advanced all the way up to 100 per cent. the actual money value of the margin allowed the retailer has remained practically stationary.

Take for example a certain make of 8-ft. binder. In 1914 the factory cost for this was \$127. On a 2-year payment basis it retailed at \$175, allowing the dealer, without taking into consideration the cost of laying down, a gross margin of \$48, or 27.4 per cent. on the sales price. In 1920 the same binder costs \$241 at factory, selling for \$287, giving the dealer a gross margin of \$46, or 16 per cent. of the selling price. During this period the cost to the dealer has increased 89 per cent., while his selling price has only increased 64 per cent., a difference which he has had to absorb into the cost of doing business.

In addition to this, the cost of laying down the implement at Saskatoon in

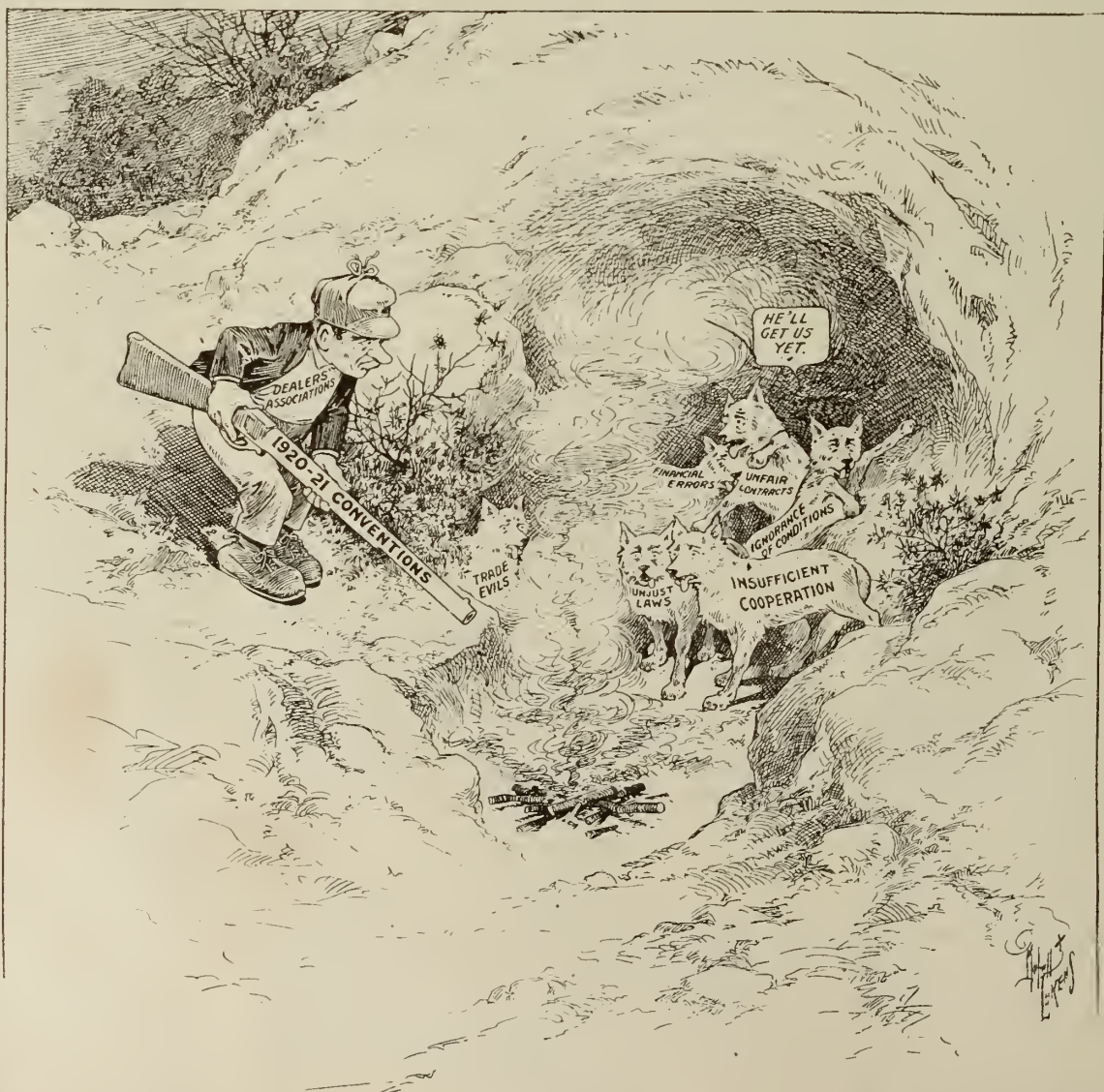

THE WOLF HUNT



1914 was \$14.25, which reduced the dealer's gross margin to 19 per cent. In 1920 the carrying charges had risen to \$20.75, which, when subtracted from the 1920 gross margin of 16 per cent., cuts it down to an attenuated 8.8 per cent. In the face of this the figures show that it costs the implement dealer 18 per cent. to do business, figures which are verified by investigations made by the Minnesota Department of Agriculture into farm implement prices in that state. The significance of these figures is that, while even in 1914 the dealer was selling 8-ft. binders, paying help and keeping together hearth and home on a margin of 1 per cent., in 1920 he is going into the hole at the rapid rate of over \$9 on every hundred he turns over.

This is the kind of "unanswerable argument" which is having the effect of making the manufacturers sit up and think.

#### Services Dealer Receives

In addition to this offensive and defensive work in behalf of the implement and automobile dealers there are a number of services to which every member of the Saskatchewan branch of the R.M.A. is entitled.

There is no business that requires the keeping of more accurate records than the implement business, and it is in the bookkeeping game that most implement men fall down—the same as in every other business in the country—the variety of lines in which he deals are subject to a similar variation in margins, and in order that he may know which of his lines are profitable and which are not it is imperative that he should keep accurate records.

The accounting department of the association, which is freely at his service, is at the present time preparing a bookkeeping system which will record the exact overhead cost on any single line of farm

machinery. By using it the dealer will know at all times which are his best profit-producing lines.

There is also a legal department to which all members may refer their difficulties for adjustment and advice. Every day auto and implement dealers are receiving information, which, if obtained from a lawyer in private practice, would cost them more than their membership fee in the association.

The traffic department is another purely service department. The service extends from the checking of freight bills for overcharges to the prosecuting of members' claims against the transportation companies for losses and breakages.

Two other services there are which the member pays for at actual cost. These are the collection department and the advertising department. Collections are made at regular rates, which are well below those of other agencies. The great advantage of using the R. M. A. service is that the collection department works all the time in the light of a credit rating system, of which every member of the association is a part. Collections can therefore be made with a minimum of effort.

#### Co-operative Advertising

In these days of keen competition the man who advertises gets the business. In the past the luxury of owning one's paid advertising expert to write business-pulling ads. has been confined to the large manufacturing and wholesale firms and the mail order houses. Co-operative advertising is a new idea. Nevertheless, any member of the Saskatchewan R. M. A. may indulge in this expensive necessity at the bare cost of the time actually taken on his work. The head of the advertising department is an expert in every phase of retail advertising, and he is always at the service of members to plan advertising campaigns, write their copy for the local press, com-

pose direct mail pieces, stuffers to go with their letters, sales letters or collection letters.

These services are being extended as rapidly as the development of the association will allow in line with the policy of extension which has been the keynote of F. E. Raymond's administration since the inception of the Saskatchewan branch of the R. M. A.

The record of good work accomplished and useful services given is having notable results. Within the past nine months the membership in the Implement and Automobile Trade Sections has increased 150 to 500, and new members are lining up every day.

#### Effects Far-Reaching

The effect has not been confined to Saskatchewan. Mr. Pizzey, the trade section secretary, has been active in infusing new life into implement and automobile organizations to the east and west, and already Alberta has organized trade sections. In British Columbia the Automotive Association has joined hands with the R.M.A. New Brunswick has recently organized her Implement and Auto Trade Sections; and in Ontario, the Automotive Association has merged with the R.M.A., and through the influence exerted from the Saskatchewan organization a single line implement association has come to life, which, it is hoped, will in time see that its interests are with the Retail Merchants' Association. Manitoba and Quebec have not yet wakened up, but the movement is young, and time is required to develop its full significance.

There is no question as to the necessity of organization, but purely provincial organizations will not be enough to give the implement dealer full recognition as a factor in business. The organization must be Dominion-wide, and the machinery which the R. M. A. is ready and able to place at the disposal of such an organization makes it the logical medium for the movement.

# Shop Layout to Facilitate Battery Work

The Modern Garage Should be Laid Out and Equipped to Facilitate all Phases of Automobile Repair Work. This Article Describes a Good Layout With Special References to Battery Service

WITH the demand for battery service daily increasing the garage man should not overlook the opportunity of establishing a business which will co-ordinate the automobile service problem.

Automobile service should mean complete accommodation and efficiency repair work. To-day too often it is anything but that. You, as a garageman, must render automobile service, not as it is being given in many cases, but as it should.

The battery and the electrical equipment are the vital parts of an automobile. In importance they are equal to any engine or chassis repair part. You equip your shop to handle these repairs. Why not batteries? Why not make your business complete, make it individual, make it really mean service by equipping your garage for battery work?

This is the era of self-starting automobiles. To the average motorist this characteristic of the present-day motor car means a great deal. However, the fact remains that for all the care which he may lavish upon the finish of his car he pays little heed to the upkeep of the electrical system of his automobile. He may be proficient and adept in the use of the oil can, but he has one tendency—to almost neglect the little black box under the cushions of the front seat known as the battery. The battery of the automobile has a story to tell of misuse and neglect in many cases. To say that the average battery needs expert attention several times a year is not overstating the case. Hence the importance of battery service.

BATTERIES have a way of suddenly ceasing to function. The average motorist becomes aware of the fact when he notes that the lights will not burn, or that the starter will not operate. As things electrical are beyond his ken with the tools at his command, he drives to the garage or service station for relief.

By F. H. SWEET

Advertising is one of the wonder workers of the present age—its benefits are enormous. The free advertising which a well-equipped battery shop receives is as much of a factor in building up a large trade as is the reputation for satisfactory work—a factor in holding the trade of the regular patron.

Too much can not be said for the layout of the shop and proper equipment. The battery service shop must also have facilities in the form of electric power to supply energy for battery charging, although generator sets may be used if power can not be obtained. Gas supply is desirable for lead burning and sweating at terminals, blow-pipe use, etc.

While a great deal of floor space need not be required for battery repair work, space must be allowed for the parking of cars without crowding. Taking batteries out of cars is heavy work, and climbing over the other cars makes it even more difficult.

Lighting in the battery section of the garage should be as good as it is in the shop. The exchange of batteries and tracing of wires and cables is much facilitated by daylight and plenty of it. I have had occasion to connect up a battery in a certain garage, which took me easily three times as long as necessary—the extra time required being due to lack of light.

With a number of cars to be checked up, batteries installed or removed, and within a reasonable amount of time, it is evident that poor lighting of the parking space may even require the employment of an extra attendant if any reputation for prompt service is to be maintained.

HAVING considered the parking space, we will now follow the battery awaiting repair through the several portions of the shop which it passes in the

process of being renovated. On entering the garage the attendant directs the owner of the vehicle to drive to a suitable place and brings his instruments with which to locate the difficulty. Finding the battery at fault, he removes it and places it on the "dolly" to take it to the shop. On the way he stops at the office, where the owner gets his receipt and signs a contract for the rental battery to replace his own temporarily.

While awaiting for the installation of the rental battery to be completed the driver's attention may well be directed, and with profit, to a small showcase containing useful and appealing electrical appliances. The attendant may also act as salesman—all of which increases the efficiency of the battery shop as a dividend producer.

In many cases the attendant upon installing the rental battery reports that his tests show the starter or the generator do not function properly. Complete electrical service is demanded by the car owner, and nothing is more conducive to good service than a supply of generator and starter brushes. Provision should be made for the stockroom to carry a line of starter brushes, fuses, generator parts, contact points, etc.—at least, for the most popular and largely used electrical systems.

THE complete battery shop must be laid out with the idea in mind of making the best use of all facilities available. Efficient service demands it. The handling of batteries, which may easily weigh up to 100 pounds, must be reduced to a minimum. The shop itself should be so laid out that as the work progresses, the battery moves in the shortest and most direct path from the racks wherein it is stored while awaiting attention to the steaming vat, and to the work bench, where it is opened, repaired and assembled; then to the charging racks



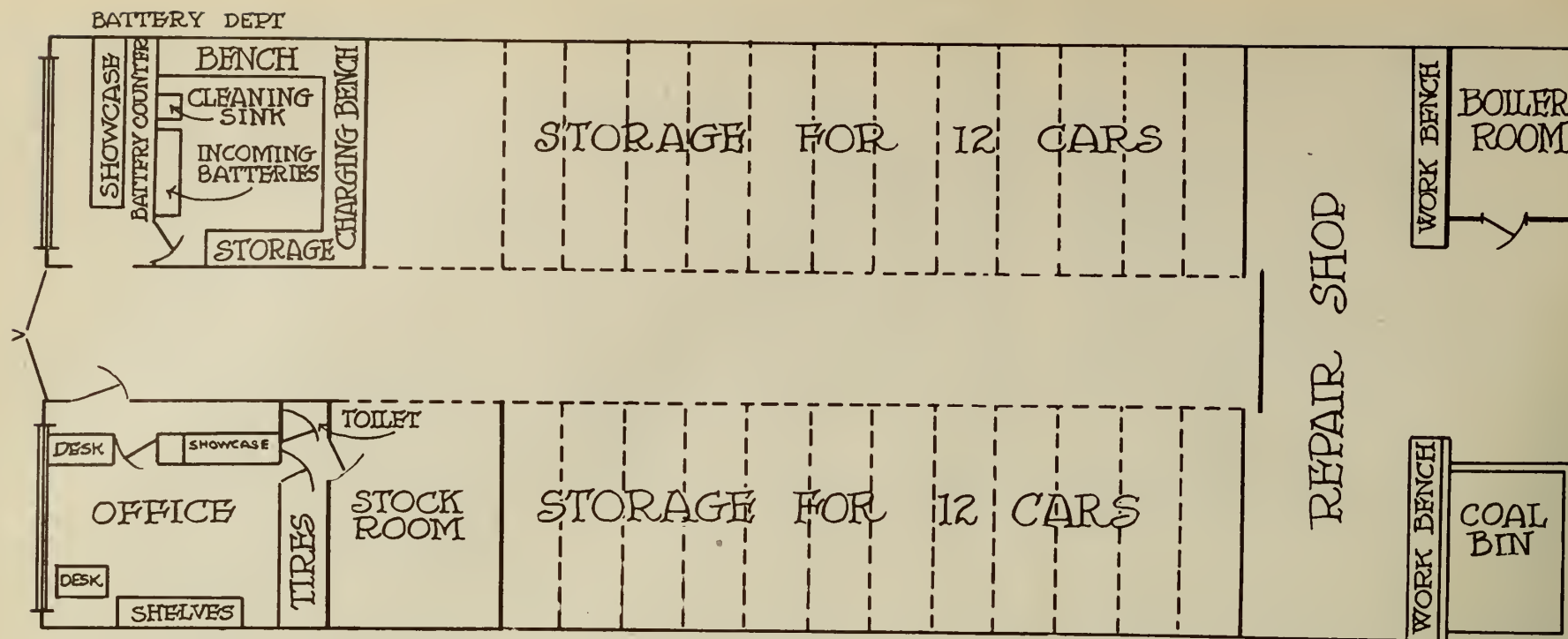

Plan showing a good layout for a modern garage.

and finally to the storage racks awaiting the car owner's return to claim it.

At best, considerable lifting and carrying is necessary and with a constant stream of batteries passing through the repairing process the workman must handle and lift as little as possible if his work is to be of the best kind.

Referring to the accompanying sketch of a garage and shop layout it will be noted that this particular battery service station is well located in the garage and equally so in its arrangement, as it is placed in the front end of the garage opposite the office.

This particular type of garage was selected because of its predominance. It may not meet the reader's garage plans or facilities, but it will serve to explain the arrangement of the equipment. Most 50 ft. by 100 ft. garages have an office on one side and use the opposite space for storage purposes. Where this is the case the storage space can be very easily utilized for a battery shop.

To eliminate as much artificial light as possible it will, first of all, be necessary to break the wall and

insert windows. A skylight would further help to light up the shop. Proper lighting is very important and should not be overlooked.

The floor space should be about 18 feet by 20 feet, with a partition and swinging doors as shown. The front part should have a showcase and battery counter. Under the battery counter drawers should be provided for repair orders, tags, etc. In the showcase an assortment of electrical equipment and accessories can be displayed to good advantage and profit.

**I**N the battery shop proper and immediately at the door should be shelves for storing the incoming batteries, and next to them a cleaning sink and battery steamer. The work bench should be located in front of the windows and immediately to the right of it the charging bench or rack. To the right of the charging bench and at the door should be another series of shelves for finished and rental batteries.

With this arrangement the battery is passed along

its course in the shop in the proper sequence and with the least amount of lifting and shifting.

Provision should also be made for parking the car when making the electrical tests. This can be taken care of by having a parking space in the garage next to the battery shop.

Next in importance to proper equipment is management. To secure the very best results it is necessary that the battery shop be managed more or less separately from the garage and repair departments; otherwise one will flourish at the expense of the others. To establish this department properly it is best to hire a good man to take complete charge of the battery shop and have him concentrate his entire attention on that work.

The electrical supplies and parts for the batteries can be kept in the main stock-room and issued on requisitions, the same as for the garage and repair departments. The repair orders should be made out in the battery shop, but payments should be made in the main office, where all transactions should be recorded.

# Giving Farm Machinery a Fair Chance

## Urge Your Customers to Consider the Value of Their Equipment, Showing Them the Importance of Properly Housing Machinery and Caring for Belts, Etc.

**D**OES your customer's carelessness contribute to the Threshermen's loss of over a million dollars annually, caused by depreciation due to exposure? Does the appearance of your customer's farm lead his neighbors to comment favorably or adversely?

Urge your customers to remedy the old, careless habits. This year when the threshing run is over urge the thresherman to consider the value of his equipment, and he will undoubtedly see the importance of making provision for properly housing his valuable machinery.

Pull the thresher in and remove all the belts. If left on the machinery they will lose their elasticity and get a permanent set in a few days. Rubber belts, if dirty, should be washed and stored in a dark, cool place. If leather belts have become dry and "husky" they should be washed in warm water and treated with a coat of melted beef tallow, or neats-foot oil. They are then ready to be rolled up and stored in a dry place away from rats or mice. With a stiff brush remove all crusty accumulations of chaff, beards, grease and dust. They hold moisture, causing rot and rust. Only by thoroughly cleaning the machine, inside and out, can it be readily seen where repairs are needed. If the farmer makes a list of parts to be replaced and orders them, he is prepared when the opportunity comes for overhauling. Every bearing or working surface should be cleaned with

kerosene and given a coat of fresh oil or grease. The thresher is then ready to be stored away until such time as it can be conveniently repaired for the next season's run. A substantial weather-proof shed providing a dry, level floor space will pay big returns on the investment. It prevents warping, rusting and rotting and also prolongs the life of the machine.

When the last furrow is turned in the fall and all field work has been finished the tractor deserves a thorough cleaning up inside and out. By cleaning up the machine the owner can readily see where bolts have become loose and nuts lost. Worn parts can be adjusted or replaced before breaking. Many a needless and costly delay is caused by the careless operator. The plow coming from the field scoured and bright requires a coat of grease to protect the unpainted parts from moisture and resulting rust.

This care applied to all machines, including steam or gas tractors, will effect a great saving and will win and keep the respect of one's neighbors.

Why not invest in a liberal sized canvas cover for the machine and keep it with the rig during operating season to protect the thresher from the dew or rain at nights and over Sundays?

To which class will the machinery users belong from now on? Will their thresher or engine, representing a large investment, and capable of earning so much, have to stand the beating storms and blistering sun of another prolonged rusting and rotting period

until the threshing season opens again, or will they be a factor in helping to put across a great movement to eliminate wasteful depreciation in farm machinery?

In travelling through any section of the country, the neglect of farm machinery is deplorable. One sees mowers, binders, rakes, threshing rigs and other machinery left out under the blue sky to rust until next season.

For a few dollars a shelter could be built which would save the farmer or thresherman considerable money during the year.

County farm bureaus have been advocating this for years, but it would seem that many farmers cannot see the extravagance of their present methods. It is a safe bet that the owner of an expensive automobile does not leave it in the farmyard unprotected.

A secure shelter is found and the machine is always run in when not in use. Cases have been known where the machinery shed has been given over to the automobile, and the mower, plow and cultivator shoved out into the yard.

Better care of farm equipment is an economic measure that should be endorsed by leading dealers everywhere.

The man who spends his money to buy should spend a little to save. A machinery shed is worth every cent put into it.



# How Auto Prices Are Affecting the West



## The Western Automobile Dealers Although Facing a Severe Crisis are Optimistic as to the Future. Wheat Prices Have Important Effect on the Industry

By G. H. SALLANS

**L**AND of hope and glory, principally hope. That seems to be about the size of things in this country right now, with the somewhat sorrowful inclines shown on industrial and commercial charts. But it is significant that hope is still here.

It would seem on taking a bird's eye view of the whole situation, from axle to hood, so to speak, as though a bottom has fallen out of the automobile business. Like so many other things, however, it is found to be a false bottom. Otherwise there would be a different tale, or no tale at all, to write. As it is, we find room for considerable hope, and the prospect of an upward curve in sales in the very near future.

Downward trends have been the fashion recently. That cannot be denied. Neither can it be helped. Therefore, it is to make the best of the inevitable, and the motor world is eminently fitted to just that thing. Incidentally it is doing it. Auto men appear prone to make things look dark complexioned. But at heart it is found they have more schemes in their heads than ever to keep the good ship up before the wind.

### Several Anaesthetics Administered

Several anaesthetics have been administered to the motor business in the West. So genuinely sedative have been their effects that a tendency to deep sleep is stealing over the entire element. Most potent of these commercial narcotics has been the first onslaught of winter, which has approached with a rather more stealthy tread this year than last, but is none the less here, so far as new business is concerned. True, the odd sales keep trickling through, but their volume is not large.

Thus, it is seen, there are two metaphors, one of agitation and instability, and the other of calm and inertia. It is unfortunate that this is so, when we speak of the present. But when it comes to futures the quotations are entirely different. The two elemental factions cannot continue to exist in the auto business world. Therefore they must compromise, and it is to this potential compromise that the next year will look for its stability, its renewed aggression, and its sales. With the false bottom gone, things are sifting down to the solid bed, and, bearing in mind always that self-propulsion is as essentially a part of the twentieth century as is political controversy, we are assured that the solid bed will be reached, perhaps before many realize. But next year will see greater methods, bigger efforts, and most likely bigger results. Certainly it will see different methods and different results.

### No Chance of Failure

The aggressive forces are throwing off the tendency to subside into hibernation, and are laying plans for a drive. There are some who have decided that conditions are bad, can't be helped, and must be allowed to settle. But these last are the exceptions. For the most part these trade builders are evolving new schemes to get their products to the ultimate consumer. And they expect success. They see no chance of failure eventually.

"Two things are going to happen," said one salesman. "The prices are going to be lower, and the cars are going to be better."

This was a rather interesting statement, and in its development he showed interesting reasons. In manufacturing circles they are getting down to greater efficiency by startling methods. Working staffs are being boiled down. Only the best men are being kept. These men will not keep the plants working to full capacity, but they will turn out finished articles. Assembly will be more thorough. Quantity comes down and quality goes up. Meanwhile, the countless antennae of the system are busy ushering the products to the outer extremity and relieving the congestion. They are unloading surplus stocks at reduced prices to make way for the specialized supply that is to come after.

### Prices Not Likely to Crash

But right here there is great difficulty. The buying public has absorbed so much about cut prices, crashing markets, and cheaper cars during the past few months that it has become wary. "Wait," says the customer. "I shall buy a car next year. Get it for about half the price I'm paying now." Maybe he will, the salesman says. But most likely he won't. Fact is, there is little to justify belief that prices will keep on crashing. They have crashed, and now they have to settle. Some makers have advanced their quotations and have not as yet dropped them. There is much fluctuation to-day, and this has to simmer down before the buyer feels safe in committing himself to what he justly regards as a big outlay.

### Organized Selling Drives

From the republic to the south come constant reports of winter drives, of organized effort to keep the buyer in the market, and these efforts are succeeding. The same element is apparent in this country, though to a lesser extent, for here, with the frigid zone not so many miles away, the tendency to hibernation, as before stated, is stronger, and the powers of resistance are weakened by the roaring nor'wester.

But our average agent has his winter business lined up in his mind and goes ahead with it with comparatively little change from year to year. He sells an odd new car, he handles second-hand goods, makes them over, and disposes of them, his margin there being a small average. Also, he holds an auction sale now and then, all of which helps. This year he finds entirely new conditions facing him.

Now, in the season of reaping, of alleged plenty, there appears in company with the general slump a substantial carving in the wheat market, and the dividends of the West's primary industry start going West.

### Wheat Affects Prices

This is the one great factor, the minus or plus of the motor chart, the price of wheat. The cost of

a car may fall \$150, it may rise \$150, the outlay for accessories may increase, gasoline may soar. These are annoying things and have their effect, but they are not vital. Twenty cents drop in wheat soon makes up the price of a whole car, let alone the fluctuation. One dealer alone lost six sales in about as many days. He had them all lined up, too.

"You have to remember," said this man, "that our trade is in the country. True, much of it is urban, but not the essential percentage that makes it a business. Anyway, conditions in town reflect the situation in the country."

### Second-Hand Business Prospects

Next I went to a second-hand dealer. "I can see no reason," that man estimated, "why second-hand business shouldn't go ahead next year. There is always great demand for the second-hand product. Made over, it is often just what is wanted. Even this year we could have made plenty of exchanges, new for old, if we had cared for such a narrow margin. We could have handled more than we actually did. Lower prices on the new cars are going to open up the market before very long and very often where a new car goes there is an old one which comes back. As to the demand for made-over cars, that will always be with us."

This man, at the end of one of the poorest years the automobile business has registered, is just putting the finishing touches to a new plant, equal in size and fittings to the older one, has nearly doubled his staff, quite doubled his business, and figures on further development in the spring. The winter he has already prepared for. He has cold-weather work ahead of him that will keep his staff employed until the thaw. The secret of it is that he is supplying a general want, and supplying it in the same manner as the up-to-date salesman supplies his shining next-season models. He doctors the sick car. If it is hopelessly distressed he will make it into something different. His is a constructive policy, and it has built for him within a very few years a modern plant with more than a hundred feet frontage.

Having found out, then, that there is life and hope in the second-hand world I dropped off the car near an up-to-date display window, walked in and asked for the khedive. He came out, a man with a twinkle in his eye, and told me that his cars were down \$160. I said, "Do you trade on that?" He straightway and emphatically answered, "I do not."

Feeling that I was going to learn something, I listened, and he said: "Advertising mediums have played on the falling price until it has come to jar on the patient."

### Heavy Duty and Taxes

The way this man reasoned it seemed to fit in all right. In the first place, the widely advertised factory drops mean much less out here than they do in the home towns of the makers. The factory cuts down 30 per cent. on all new products. Thirty per cent. on, let us say, \$2,000 at the place of making

Continued on page 35



# Selling the Prospect Who Has to be Shown

The Dealer Should Know His Line Thoroughly. No Prospect Should be Able to Ask Question Which Dealer Cannot Answer. Knowledge Begets Confidence

DAN MITCHELL, farmer, who had been reading up quite a bit on gas tractors, not to mention talking quite extensively on the subject with all his neighbors who owned tractors, decided that he'd drop in and see Sidney Sinclair, the implement dealer, at the first opportunity and maybe buy one of the critters. To be perfectly frank with himself, Dan was just about sold on a certain tractor that was doing good work for some of his neighbors. But still he wasn't one to act hurriedly. The Scotch in his make-up bade him "gang warily." He wanted to know just about all there was to know about the tractor before he was going to risk a considerable sum on such an investment.

So one day Dan called on dealer Sinclair with a view toward clearing up in his mind certain little details that he didn't understand quite as clearly as he'd like, and regarding which he sought enlightenment. Dan wanted "to be shown," but would have resented any such facetious imputation as that he was "from Missouri," for Dan was a good Canadian and mighty proud of it. He was a decidedly practical-minded one, too.

"Now, about this here tractor you're sellin', Sid—is she a real coal oil burner?" Dan wanted to know.

"Why, sure she is," replied dealer Sinclair. "Ain't that what the catalogue says it is?"

"Yes, yes—the catalogue says so," agreed Dan somewhat impatiently, "but I don't just understand some of the fine points of operation. I've heard some farmers say that kerosene tractors are no good—that they get the cylinders all gummed up with carbon and that coal oil will leak into the crank case if the engine isn't good and hot, and just naturally raise the dickens by thinning out the lubricating oil—result is scored cylinders, burned-out bearings, and all that sort o' thing. How about this Go-Good tractor of yours? Is she fixed so as to prevent condensation of kerosene in the cylinders?"

"Why, I presume she is," hesitated Sinclair, scratching his head rather doubtfully. "The salesman for the company says she'll burn coal oil with the best of 'em—and I guess he ought to know what he's talkin' about."

"I DON'T care a hang what the salesman says—maybe he knows what he's talkin' about and maybe he doesn't. What I want to know is how this tractor will do what the company's advertising says it will do, and why it will do it. That's what I came in to see you about. I thought maybe you'd know. I'm ready to put up good, hard money to buy a tractor, but by ginger, I want to know what I'm gettin' for my money. You don't ketch Dan Mitchell buying a pig in a poke! No, siree! To come back to this tractor you're sellin', what provision has it got for pre-heating the fuel mixture and what kind of an arrangement has it got for heating the engine in a hurry in cold weather so as to make it possible to burn coal oil without using up a couple of gallons of gasoline in warming up?"

"Why, you always have to start a kerosene engine on gasoline and run her on gasoline until the engine is hot," explained Sinclair, brightening perceptibly.

By B. J. PAULSON

"YES, yes—I know all about that," cut in Mitchell, more impatiently than ever. "But ain't there some way to insure complete combustion of the coal oil when you switch it on? How about these thermostatic radiation regulators that short-circuit the cooling system when starting? Has your tractor got one?"

"Come to think of it, there is a do-jigger on this tractor that does just that thing," replied Sinclair.

"Just how does it throw in the full cooling system circulation when the motor gets hot?" queried the

one of these tractors how do I know that it mightn't take a notion to sit up on its hind wheels and spill over with me when the pullin' gets real heavy? I've heard about some accidents like that with a certain little tractor."

"Oh, this tractor can't tip over, Dan—it's too heavy," stated Sinclair, taking considerable credit to himself for this last clever thought.

"HEAVY! That's just what I don't want—I want a light-weight, general-purpose tractor that's easy to handle, that doesn't pack the ground an' doesn't use up a lot of power pushin' itself around. At the same time it's got to be a safe one. It has to have

the right distribution of weight and the proper hitch adjustment to prevent any chance of her climbing over backwards and sittin' on my neck when I least expect it. And another thing I want to know, Sid—are the bull gears just plain cast iron or are they steel, hammered out of a solid ring?"

"To tell you the truth, Dan, I've been so blamed busy—can't depend on hired help any more, no matter what wages you pay, you know—that I just haven't had time to study up on this tractor. Tell you what I'll do, though—I'll get hold of the company's salesman just as soon as I can and have him come out and see you. He can give you all the information you want about this tractor. How will that suit you?"

"No, never mind—I'm kind of in a hurry—want to get me an outfit right away as I've got a few jobs waitin' to be done that I've been saving up for the tractor I'm going to buy—too heavy for horses. Well, much obliged for the information, Sid.

Maybe you've got a good tractor there and maybe you haven't—from what I can see of it she looks O. K. But I guess I'll drop over and see George Duncan and his Run-Quick tractor. He usually knows something about the machines he sells. Well, so long, Sid."

YES, only a "made up" story, you say. Quite true—that's all it is. But isn't there an idea or two in it from which you might profit? The story may be slightly exaggerated in spots, but at the same time it illustrates a great truth—the deplorable state of ignorance of the technical points of their "lines" evidenced by some implement dealers—a minority, to be sure, but enough of a minority to make it worth while to give them a "hunch" as to what's wrong with their business.

Through the medium of farm paper advertising, catalogues, letters and other advertising matter, and through the ever-increasing use of modern farm machinery, farmers everywhere are learning more and more about the mechanical side of farm implements. The more intelligent farmer purchasers are becoming increasingly critical in regard to technical points. This is especially true among the younger generation. And if the customer knows more about the machines you sell than you yourself know, what chance have you of making a sale? The prospective purchaser can counter your arguments at every turn and get you so involved that you won't know whether you are coming or going. You may have had this experience and you may not.



Before a farmer buys a tractor he wants to know all about it—and the dealer is the man to tell him.

insistent Mitchell. "That's one point I don't quite understand. Works by either expansion, doesn't it?—sort of automatic?"

"I guess you're right—that must be the way it works. Seems to me the salesman did say something about that now that I come to think of it," elucidated Sinclair.

"Well, how about the air washer—is it any better than the one on the Run-Quick tractor? Does your air washer clean the air by sucking it in through both water and a screen?"

"Now, lemme see—I couldn't just say for sure whether it does or not—but it's a first-class air washer, I know that."

"Oh, you do, hey?" commented Mitchell rather skeptically. "I just wonder! Well, anyway, aside from the air washer and the thermostat, how about removable cylinder liners? Some of the leading makes have 'em—you can pull out a scored cylinder wall and slap in a new one without replacing the whole blamed cylinder block. Is this Go-Good tractor fixed so as to make it possible to renew your cylinders that way?"

"To be perfectly honest with you, Dan, I've never looked into the cylinders," admitted Sinclair in growing perplexity, "but you can surely take my word for it that it's a good tractor, can't you? There are quite a few of 'em working on farms around here."

"No, sir, I ain't a-takin' anyone's word for it bein' a good tractor without knowin' why it's good," persisted Mitchell. "And oh, by the way—if I bought



# International and Vessot —A Profitable Combination

A Vessot Feed Grinder and an International Kerosene Engine—there you have an ideal combination for your customers. Help them utilize to the best advantage the many odd days between busy spells on the farm—give them an outfit that will pay dividends the whole year 'round. Rainy days and cold weather are no drawbacks to feed grinding but, on the contrary, add opportunities.

Say to them, "Your neighbors must have feed for their livestock. Someone has to grind it. Why not you? Custom grinding will net you a nice profit—and aside from this you can save a good deal on your feed bill by doing your own grinding."

The manufacturers of Vessot Grinders challenge

the world to produce better grinding plates than those bearing the stamp of genuineness—S.V. And more than fifteen years of engine designing and manufacturing experience by the Harvester Company is assurance that International Engines are made right—that they will render satisfactory low-cost power service.

Vessot Grinders are made in nine sizes—6½ in. to 15 in. grinding plates—and there is an International engine or tractor adapted to every size.

## INTERNATIONAL HARVESTER COMPANY

OF CANADA LTD.

HAMILTON CANADA

WESTERN BRANCHES — BRANDON, WINNIPEG, MAN., CALGARY, EDMONTON, LETHBRIDGE, ALTA., ESTEVAN, N. BATTLEFORD, REGINA, SASKATOON, YORKTON, SASK.  
EASTERN BRANCHES — HAMILTON, LONDON, OTTAWA, ONT., MONTREAL, QUEBEC, QUE., ST. JOHN, N. B.

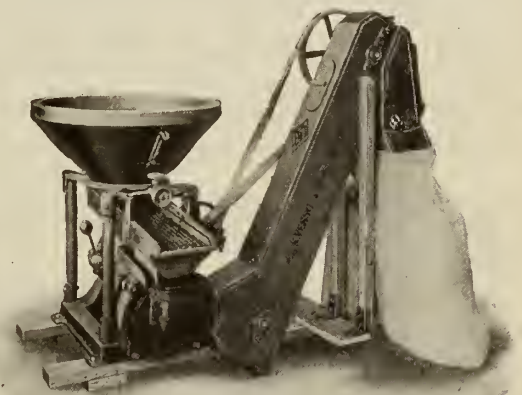
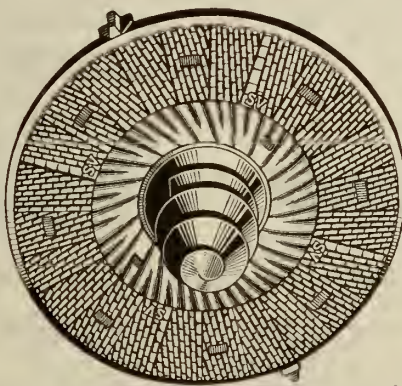

# Chatham - International Bobsleighs

## Good Winter Hauling Equipment

Urge your customers to look over their winter hauling equipment and decide whether or not it will enable them to pull through the snowy months without accident. No sense in waiting for bad break-downs on the roads with heavy loads before ninds are made up to the buying of new bobsleighs.

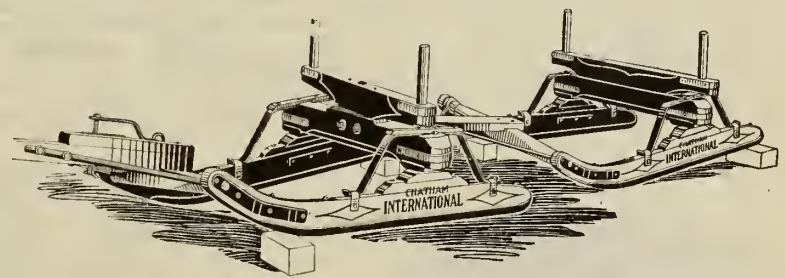

Chatham-International Bobsleighs have the rugged construction and flexibility so essential to heavy hauling over rough ground. And the unusually high clearance, which is a Chatham-International feature, makes these bobsleighs especially valuable on badly drifted roads and for hauling in the woods or over fields where there may be boulders or small stumps. The buyer is assured a strong, durable, practical, light-draft bobsleigh when he buys a Chatham-International. Ask the branch for selling assistance.

## INTERNATIONAL HARVESTER COMPANY

OF CANADA LTD.

HAMILTON CANADA

WESTERN BRANCHES — BRANDON, WINNIPEG, MAN., CALGARY, EDMONTON, LETHBRIDGE, ALTA., ESTEVAN, N. BATTLEFORD, REGINA, SASKATOON, YORKTON, SASK.  
EASTERN BRANCHES — HAMILTON, LONDON, OTTAWA, ONT., MONTREAL, QUEBEC, QUE., ST. JOHN, N. B.







# SHOP NOTES FOR THE GARAGE MAN

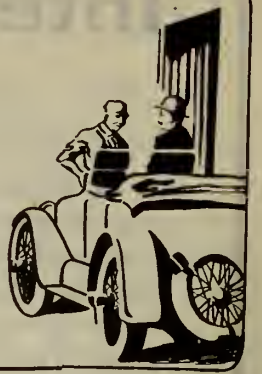

## HOME MADE BURNING-IN MACHINE

MOST repairmen are convinced that fitting automobile bearings by hand scraping is too slow. Some have purchased the modern burning-in machine but there are a number who still use the old method, or are not prepared to expend the money for a burning-in machine. The following instructions for the making of a home made machine which fits the purpose admirably will be welcomed by our readers. This machine was devised by C. Smith and Sons, power-farming dealers, of Durham, Ontario, subscribers to M.T.I., to whom we are indebted for the description and drawings.

A Ford engine and transmission supplies the power and gears are used to give sufficient power for the purpose of burning in.

The machine sits on a wooden frame, 6 ft. 6 inches long, 20-inches wide, and 2 ft. 3-inches high. Maple, 3-in. x 6-in. is used. There are three legs on each side, cross braced with 1-inch pipe flattened on the ends and bolted to the legs as shown in the cut. The Ford engine is placed at one end with radiator, coil and gasoline tank. A shaft 12 inches long is squared at one end to fit in where the universal joint usually is, and a gear is keyed to the other end. Between the gear and the engine, but close up to the gear, a bearing is placed on a wooden cross member and bolted to the under side of the top sills. An old Ford crankshaft cut off at the front end of the rear bearing is used and the part with the flange is fastened into a gear having twice the number of teeth as the gear on the shaft. The flange is left far enough out from the gear to allow a 7-16-inch nut to go in easily. The flange and gear are bolted to the flange end of the crankshaft being burned in.

To hold the cylinder block, two pieces

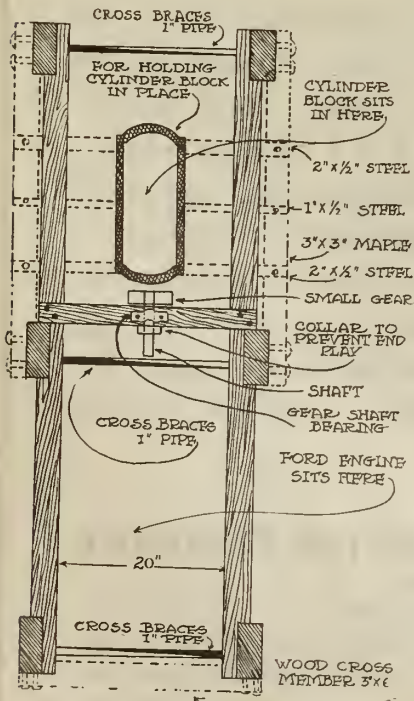

Plan of Burning-In Machine

of 3-in. x 3-in. maple are bolted, one on each side, between the end and centre legs. On top of these two pieces of 2-in. x 2 1/2-in. steel are placed to support the ends of the cylinder block, and also in the centre, between the second and third cylinder, a piece of 1-in. x 1-2-in. is placed. Four pieces of steel are bolted on top of these to keep the cylinder in place. This cylinder block frame is placed at the correct height so that the gears will mesh properly. To hold the cylinder down four 3-8-in. bolts are used and it is also necessary to employ flat

checking in one average sized shop recently showed a saving of \$397.36, in a year, following a close scrutiny of the business which resulted in stopping many of the so-called "lesser" leaks.

## Saving Solvent

For instance, with solvent costing approximately 30 cents a gallon, and with an average evaporation of a pint a day, totalling roughly, 300 pints for the year, \$90—due to uncovered containers, is allowed to float away in the air. Solvent containers should be tightly covered when not in use.

Midvale steel and also on a large number of tools made of Novo, Simeteora, Rex, Jessop, High-Speed and Blue Chip steel. On all these, good results have been obtained, but it may be added that this bath seems to give the best results with the Midvale steel.

## TAPPING HOLES IN SHEET METAL

IN order to obtain a firmer hold for machine screws, when used in threaded holes in sheet metal, drill the hole with a drill somewhat smaller than the tap to be used. Then use a drift of the proper diameter to enlarge the hole. If the tap is then used, it will be found that quite a few extra threads can be cut, on account of the drift raising a burr on the metal.

## RUST REMOVER

A NEW preparation known as "Meno" rust remover and cleanser has recently made its appearance on the market. The inventor of the preparation is a chemist of wide experience, who, realizing that the present methods of removing rust, corrosion, etc., from machines, engines, tools, parts and all metal surfaces require considerable time and high labor costs, commenced the task of devising a better and more economical cleansing method. Here is what he claims for it. This preparation is a scientific combination and blending of certain chemical ingredients, which in combination produce an electro-chemical action that rapidly loosens and dissolves rust, corrosion, grease, oil, dirt, carbon, paint or any other foreign substance that is adhering to the metal—irrespective of its age or hardness—and its action automatically ceases when contact between the cleanser and the metal is established. This is as far as it will go, for it will not injure or mar the surface of the metal itself in any way. There are two methods of using the preparation as follows:

(1) Apply it to the machine or part with a brush and allow it to remain for a short time, then brush or rub it off and it leaves the metal bright and clean. (2) Mix the preparation in a vat, tank or container with water, then attach the machine or parts to wire or chain so that they will hang in the solution. No further attention is required since the process of cleaning goes on while the parts are immersed. It is stated that the preparation is absolutely safe in every way and that it will not burn or explode. Another point is that it will not cause corrosion or rust to form, in fact, it protects metal and makes it exempt from corrosive or disintegrating action for a long period after it has been treated by this preparation, and there need be no fear of injury to the most delicate part. No matter what metal it is composed of. The preparation is said to be an economical one to use as the same solution may be used many times over, and does not deteriorate or lose its cleansing power. Peter A. Frasse & Co., of 417 Canal Street, New York, are the sole distributors, and are now establishing agencies in various parts of the country.

steel braces from the top of the sills to the cylinders to ensure that the cylinder will be held solidly. A stop is made to hold the gears in neutral and the throttle is arranged handy to the operator.

In operation the low speed is used for burning-in; the left hand operates the low speed pedal and the right hand the throttle. With a little practice it is easy to tell when the bearings are burned in sufficiently. The three main bearings are done first and then the four connecting rods. An arrangement can be fastened on the end of the frame to hold the complete engine, for loosening up and running under power, but quite satisfactory results can be obtained by using oil on the bearings—after the burning-in process—and running in high gear for a while.

The outfit should sit on a cement floor and should either be bolted to the floor or braced from the ceiling by a sturdy post to prevent it walking away—owing to vibration—when the engine is speeded up.

## CHECKING UP VULCANIZING SHOP PROFIT LEAKAGES

FEW vulcanizing shop proprietors realize the importance of checking up shop leakages, which, if permitted to lapse, steal large amounts from the yearly bank balance. There are several ways that money can slip away because of the inattention of the proprietor to some of the minor details, as he considers them, says the Goodyear Tire News. A complete re-

One slightly leaky connection in the air lines of a vulcanizing plant will add at least fifty cents a month to the power bill, and similarly, gas bills receive an additional boost when leaks in the steam line permit the live steam to escape at the rate of a few cents each hour.

## Misplaced Tools Cost Money

Have you ever been in the shop where the proprietor wondered what in the world had become of the pliers? Did his habitual complaining about lost and mislaid tools impress you that his was a model shop? Misplaced tools, besides causing much wear and tear on the operator's temper, increase the cost of jobs by delay.

The old saw, "A place for everything and everything in its place," is a homely but an exceedingly profitable motto for the successful vulcanizer to adopt.

## BATH FOR HARDENING HIGH-SPEED STEEL

AN excellent bath for hardening high-speed steel consists of a mixture of table salt and paraffin oil in the proportion of one pound of table salt to each gallon of pure oil. The steel is heated to a lemon color and plunged into the bath, being kept in motion until it has thoroughly cooled. The steel should come out of this bath gray in color and nearly free from black spots. The bath referred to can be used for almost all brands of high-speed steel with good results. It has been used to great advantage for the



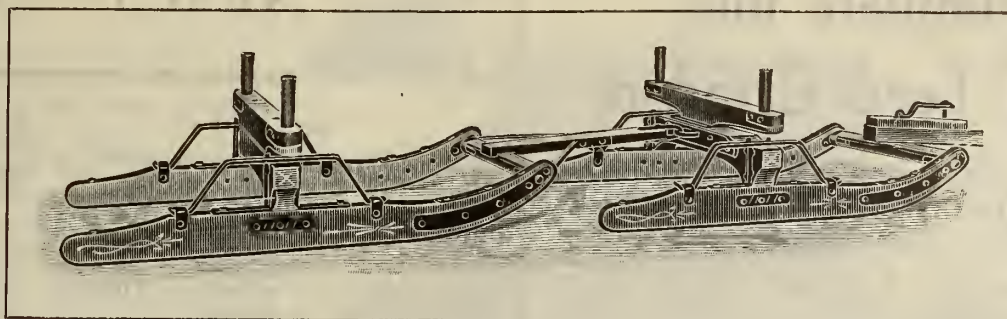

# Adams Sleighs and Brantford Cutters

Built in Canada for Canadian conditions—these Sleighs and Cutters have a splendid reputation throughout the country. You're sure to have pleased customers when you supply them with Adams Sleighs and Brantford Cutters.

## Sleighs with Rugged Strength

Heavy Oak Runners stand up under heaviest loads and hardest work. Steel or Cast Shoes are proof against holes, ruts and jolts. Benches and Bolsters are ready for years of real service. Couplings, Reaches and Chains are good for any load. There's Adams Quality in every feature—Quality that is appreciated by your customers.

## Cutters for Comfort and Style

We have been building Brantford Cutters for over 30 years and know intimately just what the trade demands. We also know how to build cutters that satisfy. Our designs are modern and thoroughly Canadian. Their finish and trimmings are the best for the purpose that money can buy. Better than all they have the Sturdy, Rugged Quality of materials that have made Brantford Cutters famous.

*Catalogues giving complete specifications of our lines of Sleighs and Cutters will be sent upon request. There is good business in sight. Go after it early.*

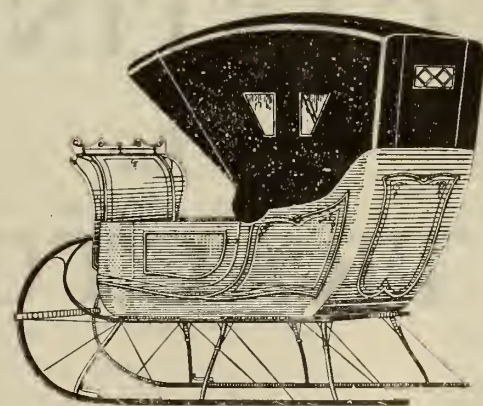

Send for our dealer proposition. It's interesting. To the dealer who realizes the value of a complete line of implements, it is a Money-maker. Cockshutt-Frost & Wood Implements, quality built, backed by steady, consistent advertising, have built up success for hundreds of dealers.

**Cockshutt Plow Co.**  
LIMITED

BRANTFORD, ONTARIO

*Sold in Eastern Ontario,  
Quebec and Maritime  
Provinces by*

**The Frost & Wood Co.**  
LIMITED

SMITHS FALLS, ONT.

Montreal

St. John





## A complete line of Feed Grinders

The dealer handling "Vessot" Feed Grinders has a decided advantage in that he has a complete line of equal quality. Nine sizes, from 6½ inch to 15 inch—a size for every farm need.

Every "Vessot" Grinder is equipped with the inimitable "Vessot" Grinding Plates that make this the best grinder on the market.

"Vessot" Grinders and Plates are known to farmers everywhere who always look for the "S.V." mark, the assurance of clean cutting and long wear.

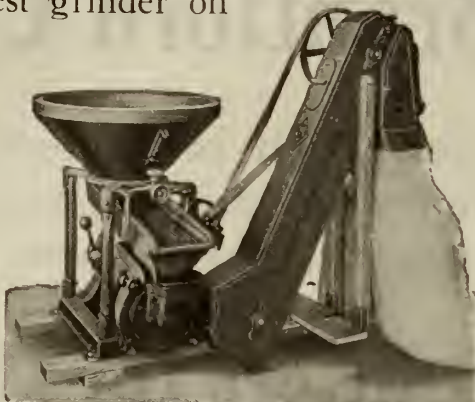

Grinder with Elevator and Bagger

Ask the nearest office of The International Harvester Company to explain the "Vessot" Agency Plan.

**S. VESSOT & CO.** Sole Manufacturers **Joliette, Quebec**

Sold by International Harvester Co. of Canada, Limited.

Branches: Calgary, Edmonton, Lethbridge, North Battleford, Regina, Saskatoon, Yorkton, Brandon, Winnipeg, London, Hamilton, Ottawa, Montreal, Quebec, St. John.

# MALLEABLE CASTINGS for TRACTORS

**The Pratt & Letchworth  
Co., Limited**

General Sales Office:

**Transportation Building  
Montreal**

## NEWS — OF THE TRADE FOR THE TRADE

### ONTARIO

**BELLEVILLE.**—An oil discovery is reported 15 miles from Belleville.

**TORONTO.**—The K. & S. Tire and Rubber Co., is extending its factory.

**LONDON.**—The London Concrete Machinery Co., is planning a \$100,000 addition to the present plant.

**WINGHAM.**—L. Kennedy, automobile dealer, has secured the Studebaker agency for Teeswater and vicinity.

**LONDON.**—The Ruggles Motor Truck Co., of Alma, Michigan, has located here and will erect a million dollar factory.

**TORONTO.**—The Dominion Battery Co. has moved to new and larger premises at the corner of Trinity and Mills Streets.

**TORONTO.**—The Anglo-Canadian Metals, Limited, 52 Spadina Avenue, is distributing the Hammond Never-Slip floor crane.

**LISTOWEL.**—H. Halliday, who is conducting a Ford agency here, in one week recently sold two touring cars, and two coupes.

**KINCARDINE.**—Cairns and Watson, automobile dealers and repairers, have recently installed a "Sun Recharger" for Ford magnetos.

**TORONTO.**—W. J. Ellis, manager of the R. A. Lister Co., Ltd., Toronto, recently paid a visit to the Winnipeg branch of the company.

**BLOOMFIELD.**—N. B. Pearsall, proprietor of the Bloomfield Garage, is erecting a new building which will be ready before Christmas.

**LONDON.**—Beatty Bros. plan to build in the spring a large extension to their Chelsea Green plant, and also a new machine shop.

**STRATFORD.**—The Macdonald Thresher Co., of Stratford, have opened a factory sales branch in the Chambers of Commerce, Winnipeg.

**TORONTO.**—The Toronto Automobile Trade Association is discussing the advisability of staging a winter automobile show early in 1921.

**TORONTO.**—It is proposed to insert the sum of \$1,000,000 in the motor bus by-law to be submitted to the rate-payers on New Year's Day.

**ST. CATHARINES.**—Fulton Motors, which was negotiating to purchase a plant and open a branch here has decided not to locate in St. Catharines.

**DURHAM.**—C. Smith & Sons, automobile and power farming dealers, in extensions to their garage and show rooms are including a rest room for ladies.

**LINWOOD.**—H. E. Keith has acquired the agency for the "Bull Dog" line of fanning mills manufactured by the Twin Separator Company of Winnipeg.

**BRANTFORD.**—The Brantford Computing Scale Co. will shortly commence the manufacture of motors and cream separators in a separate plant west of the city.

**WIARTON.**—Langford Bros., proprietors of the Wiarton Garage, are conducting a first-class repair business and handling accessories, gasoline, motor oil and tires.

**ALLISTON.**—J. D. Shanahan & Sons, builders of automobile bodies, Penetanguishene, are expected to establish a factory here, and the town council is negotiating with them to that end.

**NORWICH.**—Percy Longworth, automobile and implement dealer, has

acquired the agency for the Chevrolet car. He also has the agency for Massey-Harris implements and machinery.

**STRATFORD.**—Morley Wingrove, an employee of the Verity Plow Co., fell from an apple tree recently and broke his neck. He was conscious when picked up and was removed to the General Hospital.

**WINDSOR.**—Gordon M. McGregor, vice-president and general manager of the Ford Motor Co. of Canada, while visiting Montreal recently took ill suddenly and had to be operated upon for appendicitis.

**OSHAWA.**—Industrial conditions are improving in Oshawa. On November 15th McLaughlins commenced to increase their output of automobiles. The Chevrolet plant is expected to follow suit almost immediately.

**KINCARDINE.**—The partnership between R. M. Hunter and Roy Nelson, under the firm name of Hunter & Nelson, automobile dealers, has been dissolved. R. M. Hunter will carry on the business in future.

**COLLINGWOOD.**—Drilling interests have commenced operations near here. It is reported that five test wells may be sunk in the Craighleith district. The interested parties hope to find oil or gas in commercial quantities.

**KITCHENER.**—The new Ames-Holden auto shoe plant is now producing both fabric and cord tires. E. C. Kabel, formerly of the Dominion Rubber System at Kitchener, is sales manager of the tire department.

**GRIMSBY.**—The Baymac Tire and Rubber Company, which has been operating in Hamilton for the past year, has removed to Grimsby where larger quarters have been found. The concern manufactures automobile tires.

**TORONTO.**—Motor Sundries Corp., Ltd., has recently been incorporated in Ontario with a capital of \$500,000 and will have the sales rights in Canada on a number of automobile accessories. They will also manufacture certain accessories.

**LISTOWEL.**—The ratepayers of Listowel voted on a by-law on Nov. 27 to loan \$25,000 to a company which plans to incorporate and manufacture wheels for automobiles, bicycles and auto trucks. The by-law was carried by a large majority.

**LONDON.**—Prof. A. T. Laing, secretary of the Faculty of Applied Science and Engineering, Toronto University, gave an address before the London Motor Club recently on "Motor vehicles, headlamps and devices for the regulation of glare."

**TORONTO.**—The Advisory Industrial Committee of the Board of Education has authorized an expenditure of \$2,000 for automobile engineering equipment, tools and supplies for the Central Technical High School, for use in both day and night classes.

**BROCKVILLE.**—J. A. Sanderson, chairman of the Good Roads Commission, reported to the County Council recently that 20 miles of new road had been built this season and 40 miles graded and resurfaced. A shortage of cement, he said, had stopped further work.

**WINDSOR.**—The Wood Hydraulic Hoist and Body Company, of Detroit, is establishing a Canadian plant here for the manufacture of hydraulic hoists, and steel dump bodies for application to motor trucks. A. G. Kerr has been appointed manager of the Canadian branch.



**Pass this news along**

Attend the Sixth Annual Tractor Show and Educational Exposition to be held at Columbus, Ohio, February 7th to 12th, 1921. Pass the news along to the farmers in your locality, suggesting that they attend this big exposition. Write to the Tractor Show Manager at Columbus, Ohio, or direct to us, and a registration card will be promptly sent for you to fill out and present at the door.

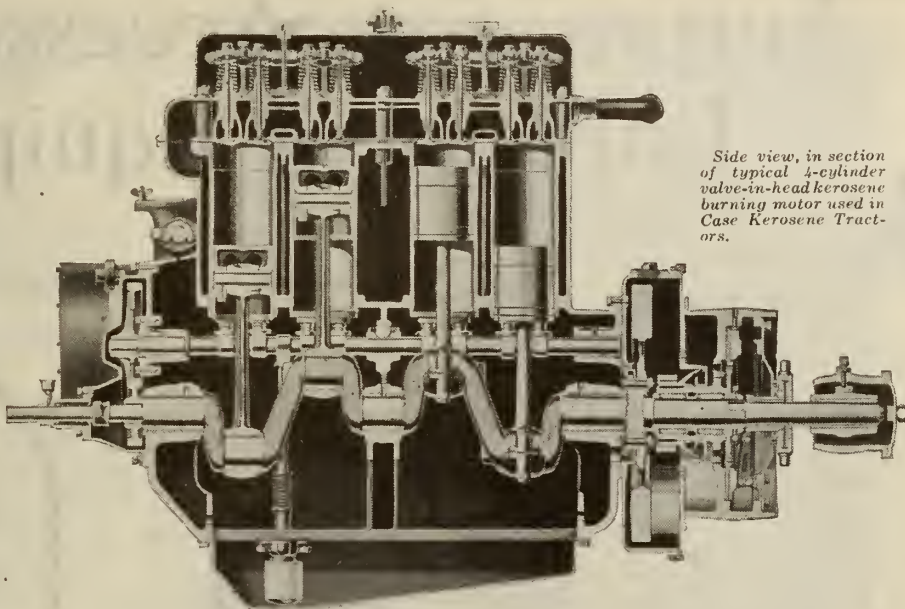

Side view, in section of typical 4-cylinder valve-in-head kerosene burning motor used in Case Kerosene Tractors.

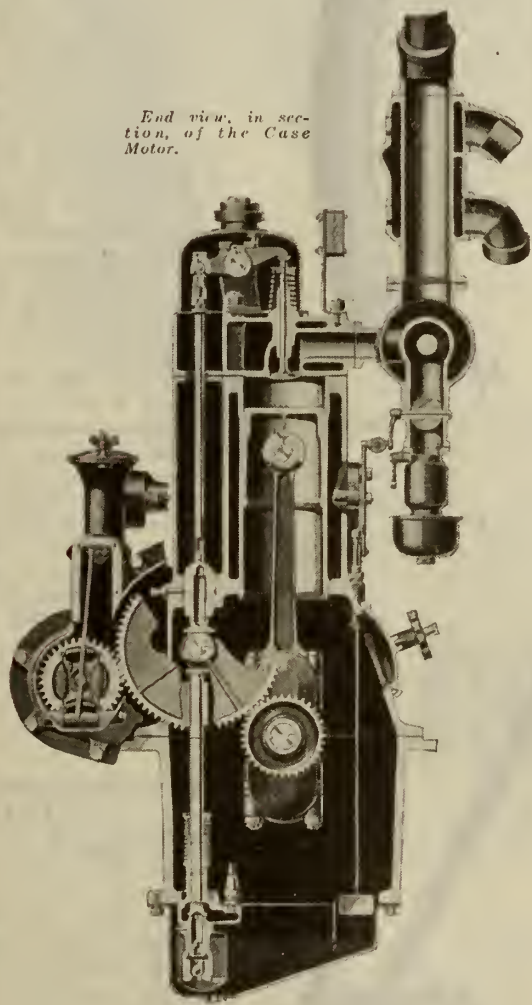

End view, in section of the Case Motor.

## Case Kerosene Tractors Have the Motor That's Built—Not Bought

ONE of the important reasons for the Case Kerosene Tractor being easy to sell and profitable to buy, is the marked superiority of its specially designed and ruggedly built kerosene burning motor.

The motor, to stand up to the grilling work and continuous service of which the Case Kerosene Tractor is capable, must be built right here in our own works—not bought elsewhere and installed. A gasoline truck motor can never be satisfactorily adapted as a kerosene tractor motor.

The illustrations on this page show the side and end views, in section, of the Case Motor of the Case Kerosene Tractor. Study them until you can put them before your tractor prospect in words.

Note the simple design and rugged construction; the heavy crank shaft and wide bearings; the valve-in-head cylinders with quick-removable head; belt pulley on crank shaft; the "velvety" clutch within belt pulley, easily accessible for adjustment.

Then remember that the motor of the Case Kerosene Tractor is mounted crosswise on the frame, permitting spur gear transmission throughout. All gears are cut steel, enclosed, and run in oil.

Dealers are invited to write for catalogs showing not only the mechanical and agricultural superiority of the Case Kerosene Tractor, but its commercial superiority as well.

**J. I. CASE THRESHING MACHINE CO.**  
(INCORPORATED)  
Dept. O-12 345-9 Dufferin St., Toronto, Ont.  
Making Superior Farm Machinery Since 1842

To avoid confusion, the J. I. CASE THRESHING MACHINE COMPANY desires to have it known that it is not now and never has been interested in, or in any way connected or affiliated with the J. I. Case Plow Works, or the Wallis Tractor Company, or the J. I. Case Plow Works Co.



Look for the EAGLE Our Trade Mark

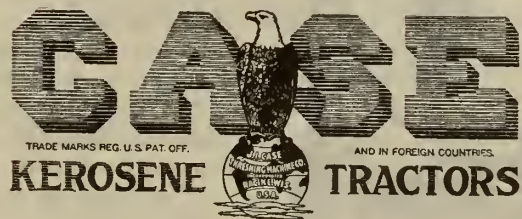



# Automotive Accessories and Implement Equipment

## STEAM CURING BAG

THE 20th Century steam curing bag is for vulcanizing the interior of a tire. It is fitted inside the tire and attached to steam line by means of a non-leakable flexible metallic hose connection. The curing process begins just as soon as the steam is turned into the bag. The intense heat generated, the makers say, cures at a uniform temperature the raw rubber both inside and out. The sectional repair after being cured by the steam bag becomes just as resilient and elastic as any part of the tire and the vulcanizer is enabled to guarantee every repair. The Steam Bag Corporation of Denver, Colorado, are the manufacturers.

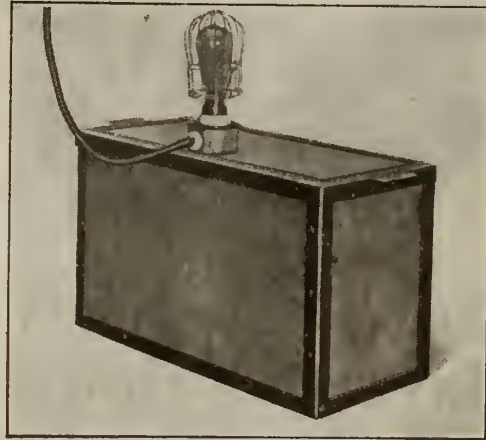

Hyrate Electric Oven

## HYRATE ELECTRIC OVEN

THE Service Station Supply Co., of 32-34 E. Larned Street, Detroit, Mich., are manufacturing the Hyrate electric oven. This they claim has been designed to produce, first of all, practical results in saving time and labor, as well as breakage, for battery tear down and that the cells are heated not only rapidly, but fairly and evenly and without burning or charring the tray or rubber parts, and thus danger from explosion of igniting gases in the cells is eliminated. They also claim that the Hyrate electric oven will do the work of several steam ovens in actual output as there is no steam gauge to watch or work of filling the boiler, as the external solid parts of the battery are thoroughly heated before the solution rises in temperature so that plates are not injured by the heat.



Badger Spring Bar Bumper

## BADGER SPRING BAR BUMPER

THE Badger new spring bar bumper embodies advanced principles of construction and design. Its construction permits it to be attached to cars of different frame widths. It is quickly and easily installed by means of hook bolts fastened on the extreme ends of the frame, either front or rear. This method insures a secure and positive attachment and the bumper cannot work loose or rattle.

The makers claim that although the bumper has been designed with beauty and pleasing conformity with the front and rear of the car well in mind, not one point that conduces to inherent strength and resiliency has been sacrificed. The main bar is made of a high grade of heat-treated spring steel, convexed in form to give it greater resiliency and shock-absorbing power. The units of its construction, the makers say, are so co-ordinated that it will absorb and diffuse the impact of severe blows without transmitting them to the frame or damaging the car or itself in any way. The main bar is reinforced with an additional length of spring steel to give it still greater strength.

The bumper is finished either in smooth, highly polished nickel plate or in black enamel. It is suitable for either front or rear of the car. It is manufactured by Badger Mfg. Corp., Milwaukee, Wis.

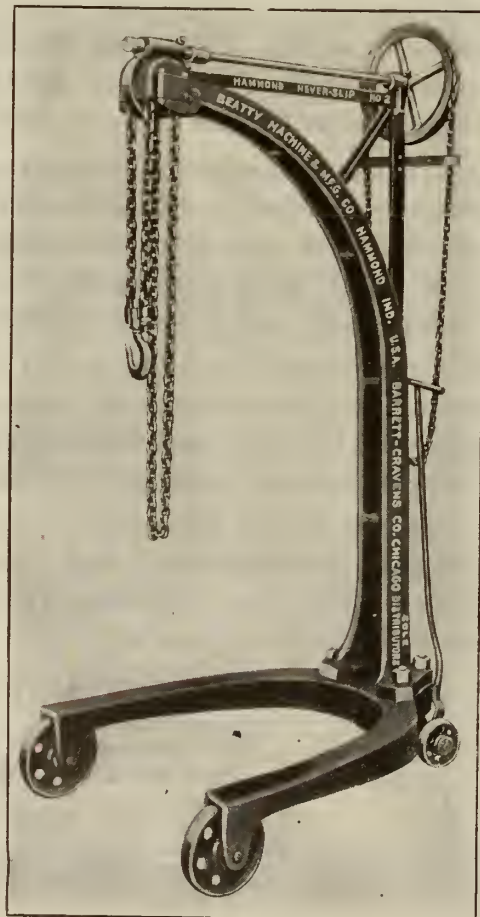

Hammond Floor Crane

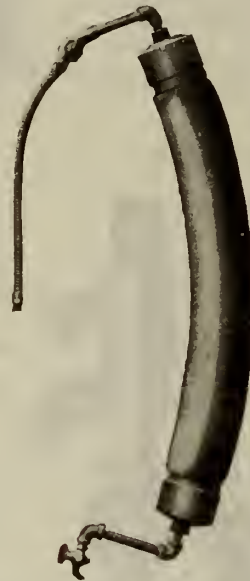

20th Century Steam Curing Bag

## B. AND D. BENCH DRILLING STAND

THIS stand, which has just been put on the market by the Black & Decker Mfg. Co., 1436 S. Michigan Avenue, Chicago, takes  $\frac{3}{8}$ -in.,  $\frac{1}{2}$ -in., 9-16-in.,  $\frac{5}{8}$ -in. and  $\frac{3}{4}$ -in. Black & Decker electric drills, which can be quickly and easily detached. The bracket-carrying drill can be raised or lowered on vertical column and is secured in any desired position by means of a split collar and clamping screw. The drill may be swung clear of the base, the makers say, making it possible to use this bench-drilling stand for such work as applying ring gears to automobile axles, drilling in the ends of shafts, and other work too high to be drilled on the bench. Both vertical and horizontal adjustment are secured by means of the clamping screw.

An extra long feed lever gives feed ratio of 6 to 1. 100 pounds pressure applied to handle feeds drill under 600 pounds pressure. In the base are six tapped holes to accommodate half-inch studs, used to clamp the work in place. One stud with nut and clamp is supplied with stand. The stand is rigid, all parts being of unusually generous size. For instance, the vertical column is a solid steel shaft 1 7-16 inches in diameter. The base is provided with four holes for fastening the stand to the bench. Four  $\frac{3}{8}$ -inch lag screws are supplied.

## HAMMOND NEVER-SLIP FLOOR CRANE

THIS crane is specially designed for the garage and machine shop and is of all steel construction. The makers says that absolute safety is assured owing to the fact that the load is locked at all points of travel. It is a "one man" crane. The lifting mechanism is of the worm and gear type and the load can be lifted to any height desired.

The worm gear is constructed of bronze and the screw is cut from solid steel shafting; both are enclosed in an oil-tight cast housing to permit proper lubrication.

The crane base and column are made from steel castings. The hoisting device rests directly on the column arm. Hyatt roller bearings are used in all wheels. This steel hoist has a sprocket of guaranteed construction. The chain is electric welded, giving great strength with the least possible weight. The axle is made of heat-treated chrome nickel steel and the base wheels have a chilled tread and are of standard railroad car wheel construction.

The crane is manufactured by the Barrett-Cravens Company, 169-173 N. Ann St., Chicago, and distributed in Canada by the Anglo-Canadian Metals, Limited, 62 Spadina avenue, Toronto; B. and S. H. Thompson and Company, Ltd., 210 McGill street, Montreal; and others in New Glasgow, Winnipeg and Vancouver.

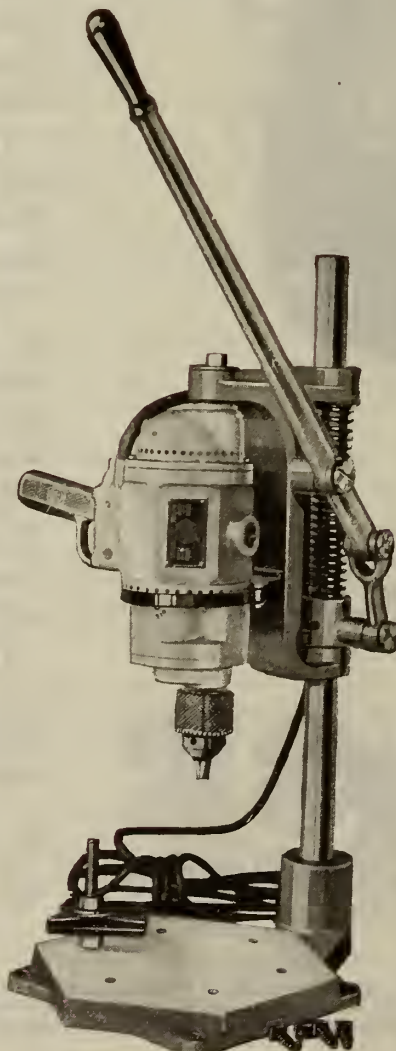

B. and D. Bench Drilling Stand



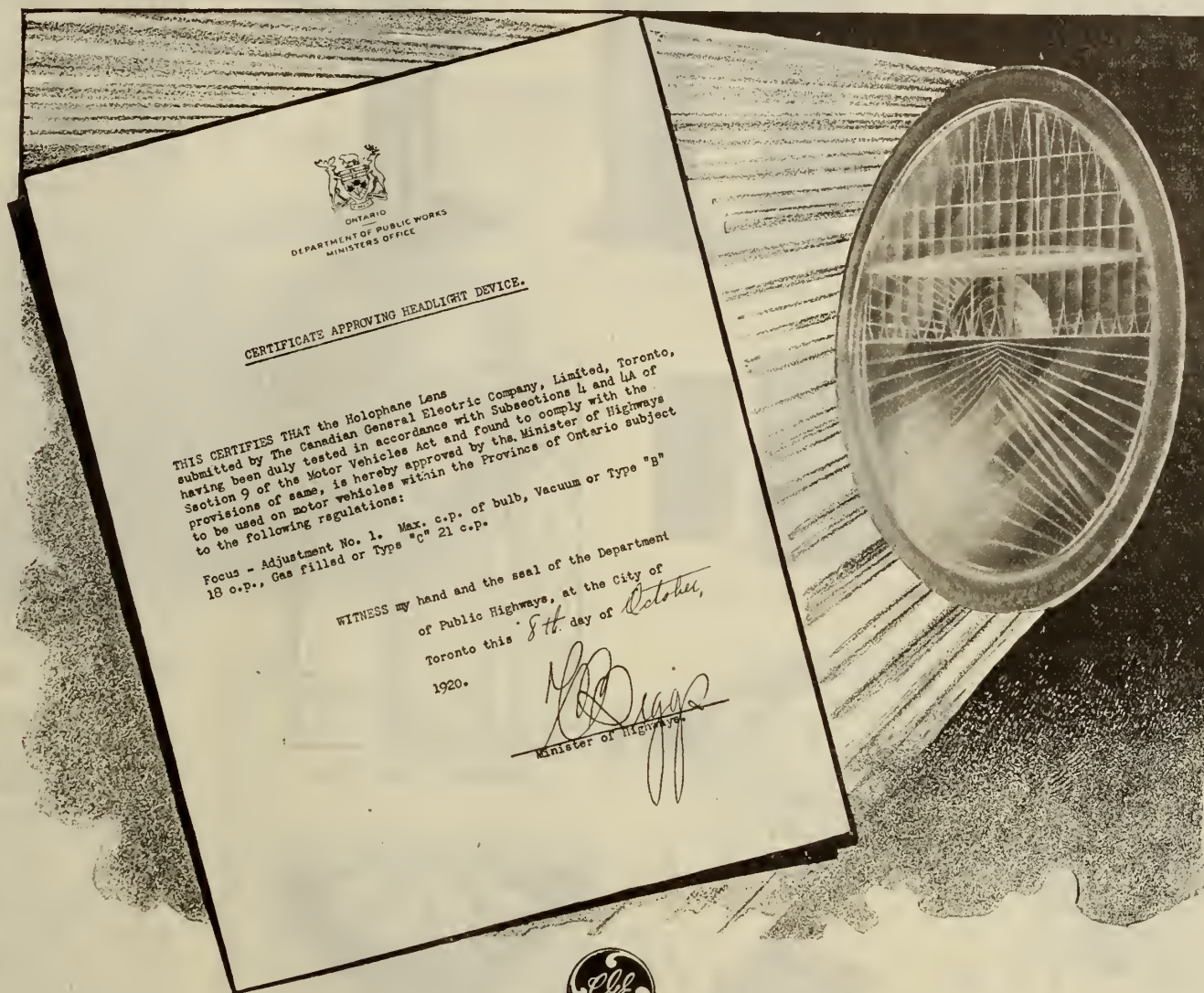

# HOLOPHANE

## Approved by the Provincial Government

**T**HE Department of Highways of the Ontario Government, in compliance with the Anti-Glare Law which was enacted last session, subjected the Holophane Lens to a rigid examination, from which it emerged triumphant.

The Anti-Glare Law is to be enforced this winter; it therefore behooves every car owner to immediately equip his car with glareless lens.

Holophane Lens are for sale by Dealers everywhere. Ask to see the "Lens with the Fin."

"TESTED FOR SERVICE"

### Canadian General Electric Company, Limited

Head Office

TORONTO

Branch Offices: Montreal, Quebec, Sherbrooke, Halifax, Sydney, St. John, Ottawa, Hamilton, London, Windsor, Cobalt, South Porcupine, Winnipeg, Calgary, Edmonton, Nelson, Vancouver and Victoria.



### MAGNETO REPLACEMENT OUTFIT FOR AUTOMOBILES

AN easy substitution of battery ignition without the requiring of additional parts is accomplished in the magneto replacement outfit which has just been added to the ignition equipment manufactured by the Westinghouse Electric and Manufacturing Company, East Pittsburgh, Pa. The same ignition head as supplied separately heretofore is used in this new equipment. The dimensions of the distributor head shaft are S. A. E. standard and the cam is constructed of self-lubricating durable material. The condenser is practically indestructible under service conditions, the makers say, and the circuit breaker contacts have demonstrated their ability to operate 10,000 miles under normal conditions without adjustment.

Connection is made to the distributor head from the drive shaft through a pinion and bevelled gear. The ignition head is mounted on a rugged base of the same dimensions as the magneto base and is secured to the bracket by four screws corresponding to the magneto support. Hence the entire process of magneto replacement with this device consists in unscrewing the magneto from its support, placing the outfit in position, resetting the screws and couplings, making connections and timing.

### IDEAL JUNIOR DOOR BUMPER

THE Ternstedt Manufacturing Company of Detroit have recently brought out a new combination dovetail bumper known as the Ideal Junior, No. 1190. The makers say it is particularly adaptable to open body construction. To apply, sink block in the body pillar and the plunger in the pillar of the door. After finishing coats are applied, install the pliable rubber cushions, shoes and enameled cover plate, and the result is a clean operating bumper, free from oils and paint. Cover plates are furnished for either 3-8-inch or 1-2-inch rabbits.

### TIRE VALVE WHISTLE

THIS valve whistle is an automatic safety pressure regulator. It consists of an adjustable spring-mounted valve that is screwed on to the existing tire valve without changing the latter in any way. It eliminates the necessity of using a tire gauge to determine the correct amount of pressure. The air supply is connected to the top of the device in the usual way and when the pressure inside the tire reaches the point set on the adjusting collar, the regulator whistles "Enough!" the surplus air being emitted through a hole in the side. The regulating collar is notched so that it cannot accidentally slip out of adjustment. Manufactured by the Automatic Safety Tire Valve Corporation, 1753-1755 Broadway, New York.

### BACON RETREADING MOLDS

THESE retreading molds are equipped with an indestructible matrix, which, it is claimed, is so constructed that any of the different types of non-skids or ribbed matrices are interchangeable, they being fully machined inside and out and composed of a metal which cannot be broken.

A feature claimed for these molds is that they allow the forming of the different type treads, such as the Royal Non-Skid or All Weather Tread, the matrix being machined to conform with the design required. Another feature claimed for the Bacon retreading molds is that in curing a tire you can clamp to the radius of the tire itself and not necessarily to the radius of the mold. This outfit generates its own steam, the water level being well below the cavity, so that only dry steam reaches it. The heat is automatically controlled. They are manufactured by the Bacon Vulcanizer Mfg. Co., 4065 Hollis street, Oakland, California.



Magneto Replacement Outfit



Atlas Jack

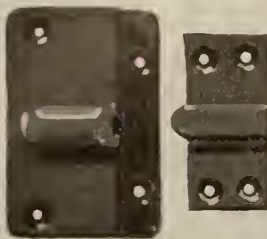

Ideal Junior Door Bumper

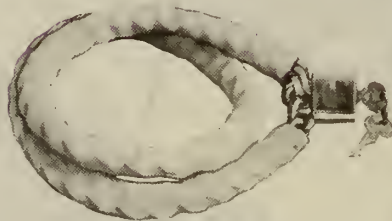

Thief-Proof Tire Lock



Lightning Coupler Link

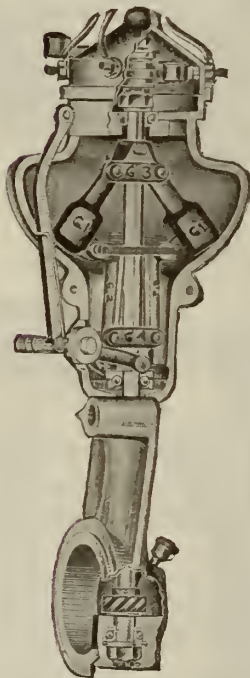

Superior Governor

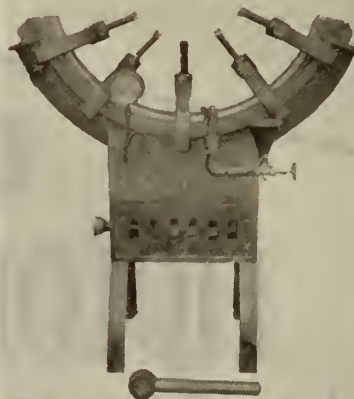

Bacon Retreading Mold

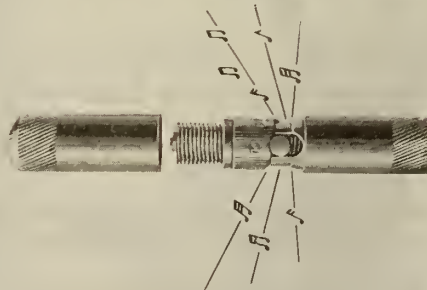

Tire Valve Whistle

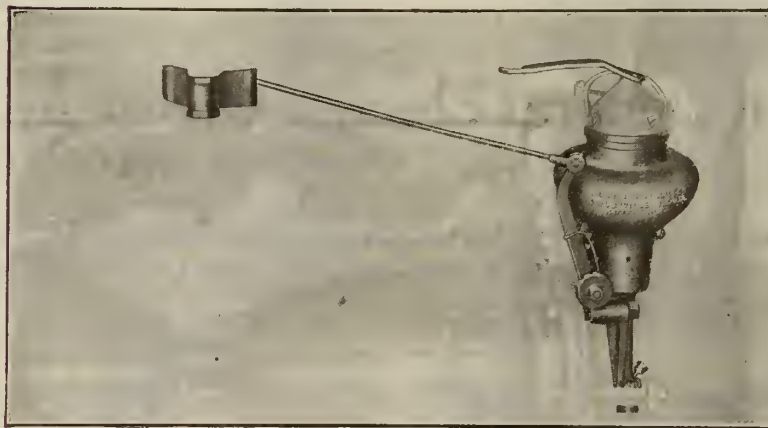

Superior Governor for Fordsons

### ATLAS JACK

THE Atlas jack was designed to give motorists a reliable and superior jack. The makers claim it is of extra strength and durability and is guaranteed to give satisfaction within rated capacity. A feature of the jack is a two-foot telescopic, extensible handle. It telescopes into a space of twelve inches. Atlas Model D has an adjustable foot lift. The foot lift is readily adjusted by hand to any height of motor car axle. This jack can be so placed as to lift a car by the hub if necessary.

It is manufactured by Kinzinger, Bruce and Co., Limited, Niagara Falls.

### SUPERIOR GOVERNOR FOR FORDSONS

THE Superior governor for Fordson tractors, manufactured by the Tractor Appliance Co., Shelbyville, Illinois, is a centrifugally-operated governor, which actuates a throttle valve located at the top of the intake manifold. It is installed in place of the commutator case. It is claimed that it increases the fuel economy and reduces wear and tear on the engine and makes the operation of the tractor simpler. The governor is so arranged that the speed of the engine can only be controlled below governor speed with the hand throttle. There are no holes to be drilled and it is easily installed.

### THIEF PROOF TIRE LOCK

THIS tire lock consists of a chain and specially designed lock. The chain is 36 inches long, electrically welded, specially heat treated and chilled, non-corrosive, and, the makers claim, cannot be cut by the strongest bolt cutters, nor can it be pried apart. It is encased in rubber tubing.

The lock is a 24-tumbler lock with hardened shackle. The makers also claim for the lock that it cannot be cut, is dust, weather, and rust proof, and non-pickable. There is a collar on the shackle to prevent loss of the chain or lock when opened. It is manufactured by the Brookins Manufacturing Co., Dayton, Ohio.

### LIGHTNING COUPLER LINK

NO tools are required, it is claimed, to repair a side chain or cross chain with this coupler link. The smaller link is the same size as cross chains and fits all sizes used on pneumatic tires from three-inch to five-inch. It does not injure tires. It is also made to fit chains used on trucks to fit up to 3/8 of an inch. It is claimed that the chains of the proper length can be coupled around the wheel and tire in a jiffy. It is manufactured by the Lightning Coupler Link Company, 1024 North Canal street, Sharpsburg, Pa.

### CONTINENTAL FORD ASSEMBLY TABLE

A NEW type of overhauling bench for the Ford motor, which is a combination of a set of engine clamps and an assembly table, arranged for the convenient handling of the Ford engine with or without the transmission, is being made by the Continental Auto Parts Co., Columbus, Ind. This stand has a table top which is 32 in. in diameter. The clamps, which are integral with the top, will permit one to hold the engine either right side up, on the side or inverted.

When the engine is on one side the stand is just a convenient height to facilitate work on the valves. The top is laid out so that two engines may be mounted on it at one time without interfering with the mechanic's work. The table top may be revolved by releasing the foot pedal clutch, making it possible to place the engine in any one of thirty-six positions.



# "VICTORY" OIL ENGINES

MADE IN CANADA



*"Sales by  
Facts"*

## No Carburetor

No Magneto  
No Batteries  
No Spark Plugs  
No Coils  
No Wiring  
No Lamp  
No Hot Bulb  
No Hot Tube

Simplest and Cheapest to operate.  
Starts and Runs on the Same Oil  
in Coldest Weather as in Summer.

## COST OF OPERATION

A 6-H. P. "VICTORY" ENGINE FOR 10 HOURS

With Fuel Oil at 18c per gallon - \$ .60

With Kerosene at 30c per gallon - 1.00

*The best Gasoline Engine will use in  
10 hours 6 gallons at 45c - - 2.70*

## Live Agents Wanted

MADE UNDER HVID LICENSE IN CANADA  
AND SOLD BY

**RAPID TOOL & MACHINE CO.,  
LIMITED**

Head Office: LACHINE, Que.

Branch: IBERVILLE, Que.

City Sales Office:

307 Coristine Building, MONTREAL, Que.

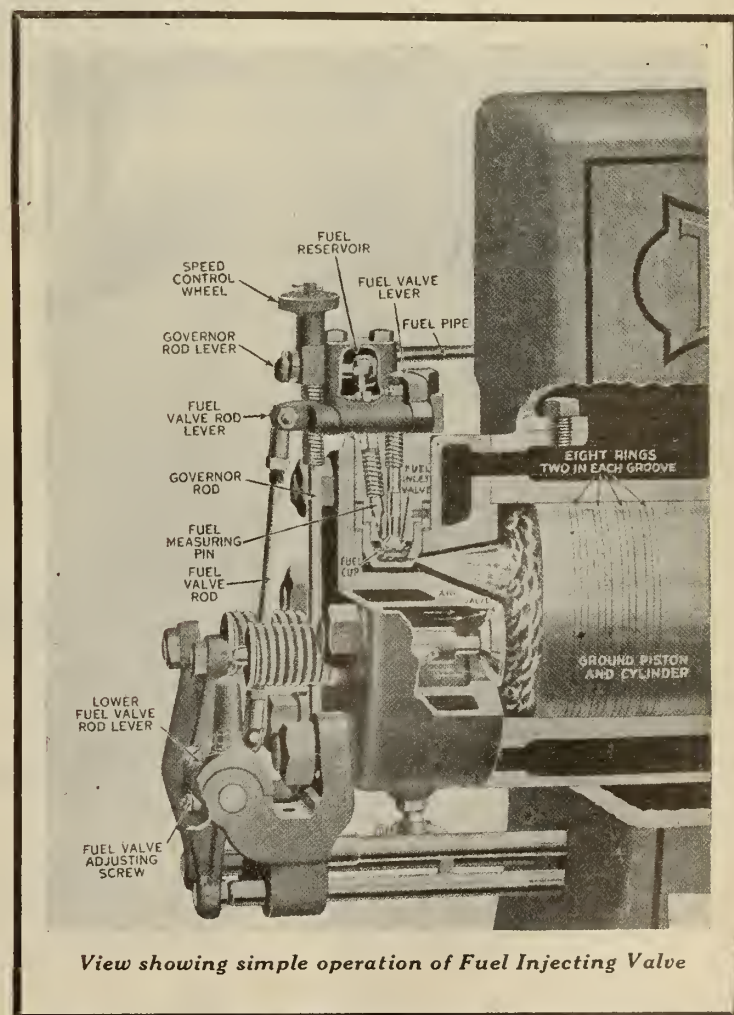

View showing simple operation of Fuel Injecting Valve



### BATTERY TEMPERATURE CONTROLLER

THIS is a simple electrically-operated device designed to control the charging of storage batteries. The "Rescue," as this device is called, is comprised of three units, namely, a thermostat, indicator and controller switch, and a resistance unit.

The thermostat is attached to a top connector on the storage battery, and held in place by a lead plated spring clamp. A wrapping of asbestos paper protects the thermostat and top connector against radiation. The indicator and controller switch is equipped with a red thermostat light and a green resistance light. The controller is mounted on the steering column directly in front of the driver, attached by a universal clamp, which fits all columns.

The resistance unit is mounted on the dash under the hood, attached by two screws or two stove bolts. This device is attached to the car in the manner shown in the illustration. The makers claim that it protects the battery against the danger of overheating. This device is simple in operation. With the controller switch set on point marked "Run," a raise in temperature in the battery to 102 degrees Fahr. closes contact in the thermostat, lighting the red signal light in the controller. The driver on receiving this signal moves the switch to the point marked "Dis." This puts out the red light, lights the green light and connects the resistance unit in parallel with the battery, thus diverting from the generator to ground the bulk of the charging current.

The flashing of the red light once during any trip or day means driving with switch on point marked "Dis" for the balance of that trip or day. On stopping the car the switch is returned to the point marked "Run." If battery temperature has returned to normal, all lights will be out in controller; if temperature is still above 102 red light will again show in which case switch should be removed to "Off" and there left until car is started again.

The device is manufactured by the Resco Products Co., Inc., Jamestown, New York.

### "BULL DOG" BOUNCE ABSORBERS

THE illustration shows the No. 1 "Bull Dog" bounce absorber fitted to the rear axle. The cut shows the adjustment that can be obtained, which also applies to the front equipment.

They are easily attached to all cars. The two models for cars except Ford take care of all weights and styles up to 4,000 pounds.

It is said to be the only device of this character that can be easily adjusted to the requirements of different weights of cars and different springs. Requires no oil and there are no metal parts that break or wear.

A brake drum and brake lining strap in connection with a tension spring stops in rebound. It does not retard the downward action of the springs, checks side sway and keeps you on the seat, it is claimed, whether going at 10 or 50 miles per hour.

"Bull Dog" bounce absorbers are made in three styles: Nos. 1, 2 and 3.

No. 1 is made to fit practically all cars. They attach to the channel frame on many cars without any attachments whatever and without drilling any holes.

No. 2 is made for cars that are drilled for devices such as bounce absorbers, snubbers, etc., and bolts directly to the frame. Many of the later built cars are now drilled for these devices, particularly for front.

No. 3 is built for Ford cars only and requires no drilling, simply fasten to the frame with U clamps and bolts. It is adjusted by the tension springs.

The makers are the Channon-Hughson Co., 229-233 W. Erie St., Chicago, Ill.

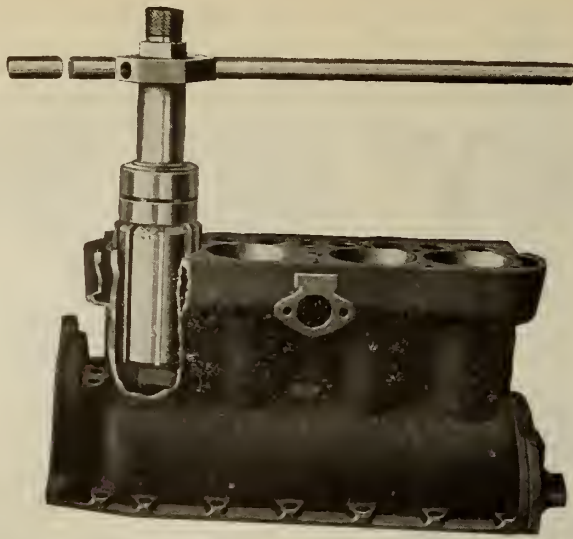

Foster-Johnson Cylinder Reamer

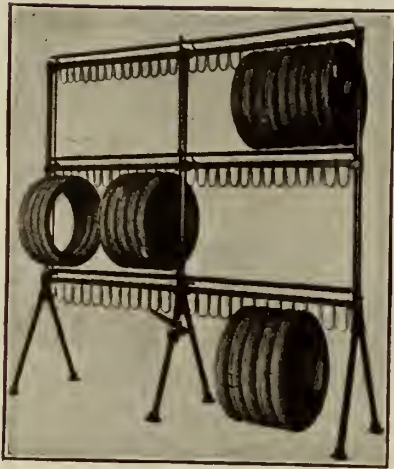

Perfection Tire Locking and Display Rack

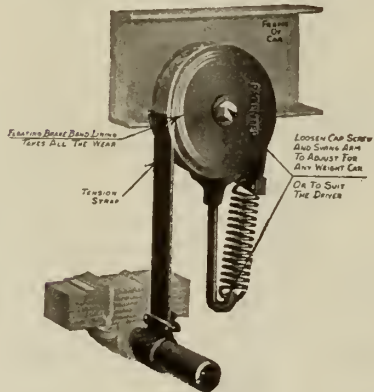

"Bull Dog" Bounce Absorber

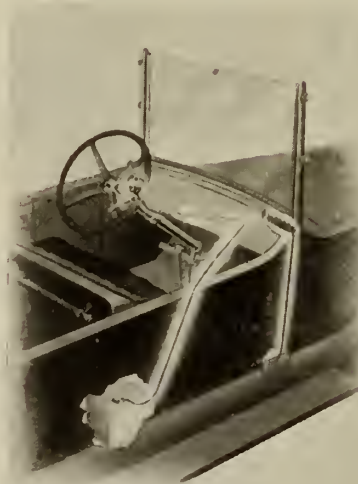

Showing Rescue Controller Installed

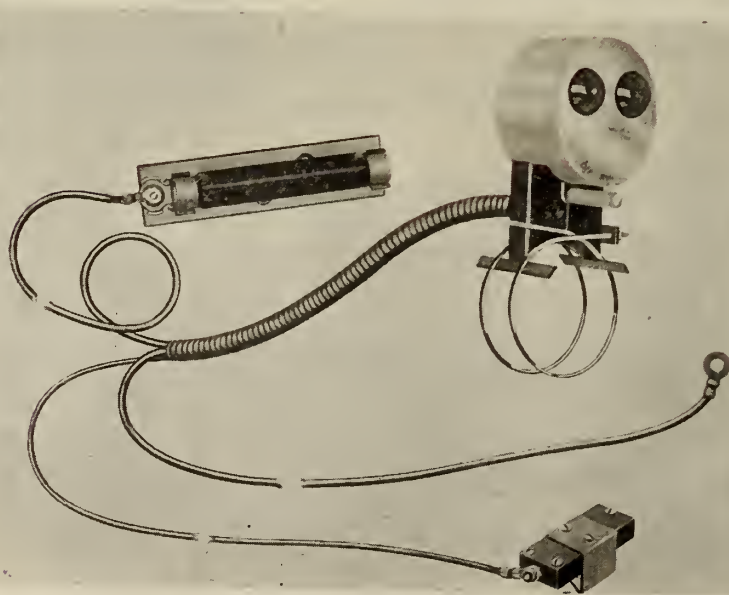

Rescue Battery Temperature Controller

### F-J CYLINDER REAMER

THE outstanding feature claimed for the F-J adjustable cylinder reamer is the ease with which it can be adjusted to any size within its range by simply turning the knurled head screw at the shank end of the reamer. The blades, which move absolutely parallel, can be expanded or contracted in the same manner as a micrometer is adjusted. The spindle collar, the springs and the adjusting nut are situated at the upper end of the blades, thus making it possible for these to extend slightly beyond the end of the body. The makers claim that because of this feature the reamer can be used for a blind hole or for reaming a cylinder block with solid head.

The blades have two tapered seats riding on the spindle, which is adjusted longitudinally by the knurled head screw at the shank end of the reamer. The movements of this tapered spindle actuate the blades in or out. A series of small coil springs seated in the adjusting nut force the blade collar against the blades and hold them rigidly on the seats of the spindle. In the body near the lower end is a beveled seat which acts as a cam and partakes in the actuation of the blades. They are made of special high carbon tool steel, carefully heat-treated and tested for hardness with the Shore Scleroscope and with a file test.

In operation the reamer is inserted in the cylinder far enough to leave the top end of the blades about one inch above the top of the block. The blades are expanded until the edges just take hold in the cylinder walls, and then about .0015 in. to .002 in. more for the cut. The cylinder is then reamed through by using the wrench as shown in the illustration. The blades are contracted, the reamer brought back to the starting position, expanded for the second cut and the former operation repeated. For the final finishing and sizing cuts the feed should be only about .0005 in. or .001 in.

As a rule the reamer will cut better when kerosene is used. Some blocks, however, are worked better when kept dry.

The reamer is manufactured by the Foster-Johnson Reamer Co., 1094 Beardsley Ave., Elkhart, Indiana.

### TIRE LOCKING AND DISPLAY RACK

THE Perfection tire locking and display rack is a store fixture which both displays tires and secures them against theft. The tire hooks are made of hard rolled steel, are easy to slip on and off and hold each tire securely in place. Each tire is displayed individually and is held in place by the hook. A locking arm simultaneously locks every tire in the rack, protecting against theft. Manufactured by the Perfection Garage Equipment Company, Hagerstown, Maryland, U. S. A.

### CONTINENTAL FORD ASSEMBLY TABLE

A NEW type of overhauling bench for the Ford motor is a combination of a set of engine clamps and an assembly table, arranged for the convenient handling of the Ford engine with or without the transmission. This stand has a table top which is 32 in. in diameter. The clamps, which are integral with the top, will permit one to hold the engine either right side up, on the side or inverted. When the engine is on one side the stand is a convenient height for work on the valves. The top is laid out so that the two engines may be mounted on it at one time without interfering with the mechanic's work. The table top may be revolved by releasing the foot pedal clutch, making it possible to place the engine in any one of thirty-six positions. Convenient slots are provided in the table top which the mechanic may use as a place for his socket wrenches and other tools. It is manufactured by the Continental Auto Pail Co., Columbus, Ind.



**NEW GENERAL MANAGER**

**T. A. RUSSELL**, president of Willys-Overland, Limited, has announced the appointment of Clayton R. Burt as general manager of the company.

Mr. Burt has had a long connection with the motor car business and is recognized as one of the most successful of Canadian manufacturing execu-



Clayton R. Burt

tives. He was for four years assistant general manager of the Russell Motor Car Company, Limited, Toronto, and for the past two or three years has been general manager of Russell Motor Car Company, incorporated, Buffalo. Mr. Burt will assume his duties immediately.

**NO PESSIMISM ABOUT AUTO INDUSTRY**

**W. P. CHRYSLER**, executive head of some of the largest automotive industries in the country, recently predicted a continued prosperity for the automobile industry of fifteen years.

"The industry has ahead of it at least fifteen years of continuing and increasing motor manufacture prosperity," Mr. Chrysler said. "This is as certain as anything in future can be if manufacturers will curb their appetite for prodigious production and salesmen cure themselves of the deadly sitting habit.

"The fit of dumps through which the industry is passing is due in part at least to indigestion due to over-indulgence. Readjustment and a return of nearly normal conditions is a matter of weeks now rather than months, provided the remedies referred to are applied. The cue for the future in the motor car business should be moderation in everything except hard work.

"Discontinuance of production and delay in resuming it will almost certainly bring about another shortage in good motor cars next spring. There probably will never again be a shortage in poor motor cars. The demand for good cars already offers relief from the doldrums of the last few weeks. Sales are increasing satisfactorily from day to day.

"Business is not dead—nor even seriously ill. It is merely in need of exercise. And the best exercise I know is to give the public a good value for its money and work hard to show the public you mean business. Manufacturers and dealers who haven't forgotten how to sell good merchandise are not worrying about the future. The chair warmers are rapidly going by the boards.

"Make no mistake, the automobile business is alive and strong. I don't believe in wild optimism which is based on desire rather than on facts, but I haven't any sympathy for the black pessimist who sees only disaster. No

catastrophe has happened to deprive people of their purchasing powers or their desires for motor cars. Spinelessness and gloom are, therefore, pure nonsense.

"The pessimists are the weaklings who expect business to be laid in their hands. The hard workers aren't gloomy. And I honestly hope that we will never again have business conditions which put a premium on incompetence. I am for the real workers and the good cars—and I have unbounded faith in the stable market and solid industry they are building."

**FARM IMPLEMENTS MADE IN CANADA**

**A**GRICULTURAL implements with a selling value at the works of \$36,703,943 were manufactured in Canadian plants during 1919, according to the preliminary report on this industry recently issued by the Dominion Bureau of Statistics. Total capital invested in the industry was \$83,276,450, of which \$77,693,500 was invested in Ontario. The statistics cover the operations of 86 plants distributed by provinces as follows: Ontario 51, Quebec 20, Manitoba 7, Alberta 3, Saskatchewan 3 and Prince Edward Island 2. Classification under the item of capital invested shows that \$13,377,642 was invested in land, buildings and fixtures, \$7,156,394 in machinery and tools, \$34,521,554 in materials on hand, stocks in process and finished products on hand; \$34,000 in fuel and miscellaneous supplies and \$28,220,860 in trading and operating accounts.

The number of employees in the industry is given as 10,242 male and 566 female, and the total of salaries and wages was \$11,858,013. The classification of employees by weekly wage payments are given as follows for males over sixteen years: Under \$10 per week, 114; \$10 to under \$15 per week, 611; \$15 to under \$20 per week, 2,235; \$20 to under \$24 per week, 2,193; \$24 to under \$28 per week, 1,751; \$28 to under \$30 per week, 670; \$30 and over, 1,601.

Fuel used during the year was valued at \$721,801; this item included 46,949 tons of coal; 13,638 tons of coke; 34,060 quarts of gasoline, 2,239,341 gallons of fuel oil; 2,348 cords of wood; 13,381,000 cubic feet of natural gas.

Raw materials having a cost value at the works of \$16,520,146 were used. These are itemized as follows: Steel and steel castings, 65,843 tons, \$5,577,067; iron and steel castings, 40,055 tons, \$1,838,566; malleable iron, 20,769 tons, \$1,226,917; lumber and timber, 42,986 M. feet, \$2,051,030; all other materials used, \$5,826,566.

The total quantities and selling values of the various products at the factory or works aggregated \$36,703,943, and are itemized for principal products in the following summary table:—

Classes of products	Quantity No.	Sell'g value at works.
Drills, grain	27,912	\$ 3,560,631
Cultivators, wheeled and other	41,149	1,378,526
Harrow, disc, spring and spike tooth	33,746	1,452,463
Plows, all kinds	70,372	3,355,773
Plows, tractor	4,170	742,250
Harvesters, grain	29,949	5,169,075
Harvesters and threshers combined	660	340,083
Hay carriers	4,270	274,040
Hay loaders	5,557	475,493
Hay tedders	670	34,005
Hay rakes, horse	15,375	566,735
Mowers	82,019	1,821,858
Threshers	5,691	3,071,078
Fanning mills	7,266	291,902
Tractors	1,827	865,063
Choppers, pulpers, etc.	6,447	246,144
Manure spreaders	5,715	1,093,080
Cream separators	3,291	203,220
Engines, steam	103	198,244
Engines, gas	633	187,555
Wheelbarrows	11,384	61,689
Castings and machinery parts	...	1,044,592
All other miscellaneous products	...	6,303,033
Custom work and repairs	...	4,067,411
		4,067,411
<b>Total selling value..</b>		<b>\$36,703,943</b>

# More Power from Less Fuel

Tight up against the cylinder walls at all times Excellence Two-Piece Piston Rings prevent the escape of compression. The full force of every explosion is expended on the cylinder head and so becomes power. No oil can leak through to carbonize the spark plug, no unconsumed gas escapes, and so every explosion is of full force—there is absolutely no waste.

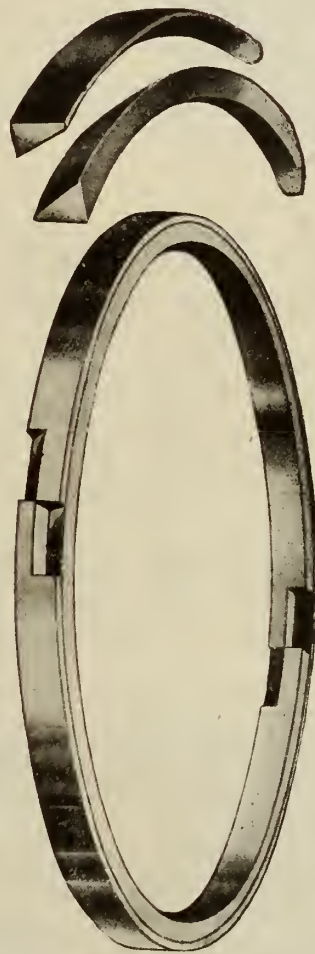

*The Only Perfect Piston Ring*

## EXCELLENCE TWO-PIECE PISTON RINGS

mean more power from less fuel.

They are easy to sell to a customer because their principle of operation is obviously correct. Any motorist can quickly grasp the fact that the two halves are so shaped and fitted together as to insure prompt and certain contraction and expansion as need arises. The joints will not work loose or shift; consequently the ring fits snugly at all times, making a perfect seal for the firing chamber.

Recommend and install Excellence Two-Piece Piston Rings. The satisfaction they give and the economy they make possible will be reflected in increased business for you.

*Manufactured exclusively and distributed by*

# LAMONTAGNE LIMITED

Wholesale Dealers in Automotive Equipment

QUEBEC MONTREAL WINNIPEG



## A 24-Hour Radiator Repair Service



Why fuss with troublesome radiator repairs? They can be more cheaply and effectively executed by the manufacturer.

Ship any make to our Repair Department and in 24 hours, or less, it will be on its way back to you—freight or express as you instruct.

We promise you no wait service and A No. 1 workmanship.

**McCORD MFG. CO.**  
WALKERVILLE, ONTARIO

WE GIVE

## “Quality and Service”

IN

## TRACTOR and TRUCK STEEL CASTINGS

### Joliette Castings & Forgings Limited

Head Office:  
Transportation Bldg., Montreal

Works:  
Joliette, Que.



## It Docks at Your Desk

Our service brings to your desk news items collected from the newspapers relating to your line of business.

Often you plan your affairs on market conditions or new developments, but you could plan much better with all information before you from the whole of Canada.

These newspaper clippings have proved most valuable to business houses, saving time in searching files and often being turned to good account, getting contracts and orders.

We cover all parts of Canada and United States and read for all subjects discussed in the press.

Have the news packets arrive regularly at your desk with a cargo of timely news.

**Canadian  
Press Clipping Service**  
143-153 UNIVERSITY AVE., TORONTO

### MONTREAL MOTOR SHOW

**SUCCESS** is assured for the Montreal Motor Show, which is to be held by the Montreal Automobile Trade Association, Limited, from January 22nd to January 29th, inclusive, in the mammoth Motordrome building, Sherbrooke Street East. This building is located in the rear of Sherbrooke St. between Sanguinet and St. Denis Streets. More exhibitors are registering daily and everything points to a most complete display of automobiles and accessories and a large attendance of manufacturers and their representatives. The opening is officially set for January 22nd, 1921.

Below is given a first list of applications representing leading firms in the automobile business who have registered as exhibitors:

Allied Motors Limited, Albion Motor Car Co. of Canada Ltd., Geo. M. Primm, Packard Montreal Motor Co. Ltd., The Franco Canadian Automobile Co. Ltd., Montreal Motor Corporation Ltd., Mapleleaf Mfg. Co. Ltd., The White Co., Ltd., Montreal Automobile Co., Imperial Oil Limited, McCall Bros. Limited, Cutten & Foster, Prest-O-Lite Co. of Canada Ltd., Goo & Patrick, S. F. Bowser Co. Ltd., Canadian Oil Co. Ltd., Loyal Oil Co. of Can. Ltd., H. H. Mellor & Co., Dominion Chain Co., McLaren Bros., Mutual Motor Truck Co. Ltd., Pierre J. LeMay & Cie, Grenier Motor Co. Ltd., Canadian Motor Sales, Legarè Automobile & Supply Co. Ltd., Frigon & Baker, John Millen & Son Ltd., A. J. Hopkins, Champion Ignition Co., Montreal Motor Sales Ltd., Lamontagne Limited, Willys-Overland Limited, K. & S. Tire & Rubber Goods Ltd., Ames-Holden McCready Ltd., Ludger Gravei & Fils, Montreal Vehicle Motor Co. Ltd., Renaud Rubber Supply Co. Ltd., Oak Tire & Rubber Co. Ltd., Motor Sundries Corporation Ltd., L'Automobile au Canada, Canadian National Carbon Co. Ltd., L'Air Liquide Society, Arlington Bicycle Co., Ledoux Jennings Co., Ford Motor Car of Canada, Montreal Automobile Club, Dominion Rubber System (Quebec) Ltd., Dunlop Tire & Rubber Goods Ltd., The Goodyear Tire & Rubber Goods Ltd., Gutta Percha & Rubber Ltd., Champion Spark Plug Co. Ltd., Canadian Fairbanks-Morse Co. Ltd., Semmel-Haack Dickson Ltd., Gisberg Motor Co., Motor Car Distributors Ltd., Armstrong Whitworth of Canada Ltd., Gray Dort Motors Ltd., Universal Tire Service, Frontenac Sales Co., John H. Feeley, Cadillac Motors Ltd., Hyslop Bros. Ltd., McLaughlin Motor Car Co. Ltd., Omer DeSerres, Canadian Asbestos Co., Detroit Radiator Co., McKinnon Industries Ltd., General Automobile Equipment Ltd., Robert H. Hasler, Coffield Tire Protector Co. Ltd., Chas. E. Goad Engineering Co. Ltd., Modern Vulcanizing Co.

### LOOK FOR HIGHER CAR PRICES

**THE** Automotive Industries Association, with a membership of fifty companies engaged in the manufacture of automotive vehicles, accessories, tires and parts, held its annual meeting in Toronto. The feeling of the members regarding the future was that further revision of prices is likely to be upward. This thought is based on the demand for automobiles which 1921 is expected to witness, if for no other reason than making good the natural annual replacement needs of the country. These alone should mean renewed activity at the factories, but inasmuch as the orders from dealers are not being received in sufficient volume, the manufacturers are not placing material contracts, consequently the manufacturers feel that any revival of orders in the spring may find the factories unable to make delivery. The following officers were elected:

Pres., R. S. McLaughlin, pres. General Motors Corp.; vice-president, W. T. Samson, Gananoque Spring and Axle Co.

Directors: T. A. Russell, Willys-Overland, Ltd.; G. M. McGregor, Ford Motor Co. of Canada; J. M. Taylor, Taylor-Forbes Co.; W. A. Rolland, Steel

Co. of Canada; C. H. Carlisle, Good-year Tire & Rubber Co.; Robt. Gray, Gray-Dort Motors, Ltd.; R. E. Jamieson, Dominion Rubber System, Ltd.; secretary, W. G. Robertson, Ontario Motor League.

### APPOINTED GENERAL MANAGER

**THOMAS BRADSHAW**, who last spring went to the Massey-Harris Co. as treasurer, has been appointed general manager. Mr. Bradshaw was at one time a partner in the firm of A. E. Ames & Co., and was considered one of Canada's leading experts in municipal finance. During the war he was appointed Finance Commissioner for the City of Toronto and succeeded in putting the financial affairs of the city on a sound basis. His reports on Toronto's financial activities were considered by civic treasurers throughout Canada as models of their kind and his opinions have always been valued, except within Toronto's own civic circle, where Mr. Bradshaw's recommendations were repeatedly turned down. In his new position, Mr. Bradshaw will be assisted by C. L. Wisner as assistant general manager in charge of sales, and George Valentine as assistant general manager in charge of manufacturing.

### MASSEY-HARRIS PRESIDENT RESIGNS

**THOMAS FINDLEY**, until recently president and general manager of the Massey-Harris Co., has resigned from the latter position on account of ill-health, but will continue as chief executive of the company. Mr. Findley worked himself to the top of the vast Massey-Harris organization inside of twenty years. Starting in as a telegraph operator he successively filled almost every post in the organization—clerk, foreman, superintendent, assistant general manager, general manager, director, president. His recent paper before the Tariff Commission was one of the best arguments for a tariff in Canada that has yet been presented.

### OAK TIRE CO. REORGANIZED

**REORGANIZATION** of the Oak Tire and Rubber Co., Ltd., is taking place, and in connection with the increase of the authorized capitalization from \$400,000 to \$3,000,000, a stock dividend of 100 per cent. is being paid to shareholders in the original concern. A quarter of a million dollars of 8 per cent. preferred stock will be sold to provide funds for extensions to the plant at Oakville, Ont., and for machinery and working capital.

The company was originally organized in 1916. The capacity at present is 300 tires a day, but when the extensions to be provided out of the present financing are completed the capacity will be 500 tires a day. Directors of the company are:

President: Douglas S. Murray, of the Murray Printing Co.

Vice-president: G. G. Blaxton, barrister.

Directors: T. A. Finley, manufacturer, Norwood; A. E. Willard, Galt; William Seward, Baltimore; F. D. Law and Dr. S. M. Hay, head of the Western Hospital, Toronto.

### MOTO METER FACTORY FOR HAMILTON

**OWING** to the increasing demand for Boyce moto meters in Canada the company have established a factory at 56 Alanson street, Hamilton, Ont. This company has over 175 standard equipments on passenger cars, trucks, tractors and motor boat. Samuel E. Ryder, who was their equipment engineer, located at Detroit, and one of the old timers of the concern, has been made general manager of the Moto Meter Company of Canada, Limited, and has already assumed his duties there.



## RUGGLES MOTOR TRUCKS

THE Ruggles Motor Truck Co., Ltd., a new truck concern, has decided to locate in London, Ont., and commenced erection of first unit of its plant, a building 417x80 ft., constructed of brick and steel sash. Three sizes of motor trucks will be turned out, 1½ ton, 2½ ton and 3½ ton. The principal officers are: President, F. W. Ruggles; secretary, E. L. Smith; treasurer, M. Pringle. Other officers are: G. R. Wilber, director of purchases; C. D. Smith, in charge of manufacturing; D. M. Britton, in charge of engineering. The capitalization is three million dollars.

## LONDON MOTOR SHOW

THE National Motor Show of Western Ontario will be held at London, Ont., from January 31st to February 5th, 1921, inclusive, under the auspices of the London Automotive Retailers' Association, and tremendous enthusiasm is being shown by the dealers.

At the special meeting of the association held recently, the total amount of 75 per cent. of the space was taken and prospects are exceedingly bright. The services of T. C. Kirby have been secured as show manager and his vast and varied show experiences of 11 years will assure the success of the show.

Passenger and commercial cars, tractors, and accessories, as well as motor cycles and bicycles will be exhibited. The show will be run on co-operative lines, the association taking the profits and rebating pro rata to its member exhibitors.

## CHEVROLET SALES MANAGER HONORED

MEMBERS of the Oshawa Lion's Club recently banqueted R. H. Mulch, who is leaving the town to take a responsible position with the Chevrolet Motor Car Company of New York city. For three years Mr. Mulch has been Chevrolet sales manager here and took an active interest in the public affairs of the community.

Salesmen from all over Eastern Canada were present at the banquet, including representatives from Moncton, N.B., Montreal, London, Ottawa, Toronto and Hamilton.

## ASK CHANGE IN FREIGHT RATES

APPLICATIONS for reconsideration of the equalizing of freight rates between Eastern and Western Canada has been made to the Board of Railway Commissioners by the Canadian Manufacturers' Association.

The application is based on the recent order in council issued by the committee of the Privy Council recommending that the Board of Railway Commissioners reconsider their judgment in regard to the recent increase of freight rates granted the railways.

The Manufacturers' Association claims that conditions have materially altered since the board's order in the Western rates case was issued in 1914, and draws particular attention to rates in British Columbia and the Maritime Provinces.

## A NEW FOLDER

THE tractor division of the Hyatt Roller Bearing Company has just issued to the trade a very interesting anti-friction bearing specification folder in the handy railroad "time-table" size. When unfolded it forms a large wall chart that shows not only Hyatt bearing locations, but the locations of all makes of anti-friction bearings on all prominent types of tractors. There are eighty-seven manufacturers of wheel type machines and eighteen track-driven type machines listed. In each instance, the bearing specifications

have been carefully checked by data supplied by the various manufacturers to make certain their correct tabulation. A limited number of these charts are available for further distribution and may be had by writing the Hyatt Roller Bearing Company, Chicago, Illinois.

## I.H.C. OFFICER DEAD

A SUDDEN and severe loss was sustained by the I. H. C. organization in the untimely death on Sunday, Oct. 31st, of Samuel Dexter Snow, who had been a member of the legal staff ever since the company was organized and had for more than a year occupied the important office of general attorney. The funeral was held Tuesday afternoon, November 2nd, at Buena Memorial Presbyterian Church, Chicago.

## NEW ACME FOLDER

THE Acme Motor Truck Company has just issued a folder covering the various trucks they build entitled "Making Money by Modern Methods." The folder is attractively gotten up and numerous illustrations show trucks being used for all commercial and municipal purposes.

## LOCATING DEFECTIVE INSULATION

A SIMPLE device for locating short circuits, open circuits and "grounds" can be made by any repairman with the use of a pair of ordinary awls, a wire loop and a test lamp. The object in view is to bridge over the imperfect electrical circuits and in this way locate them. The points of the awls are inserted through the insulation of the wires under test. The awls are each connected to the wire to which the test lamp is attached as shown in the illustration. In testing wires where there is no current in them it will be necessary to provide some means of supplying current and batteries connected to this device serve to accomplish the end in view.

## PRODUCTION OF BENZOL AT HAMILTON

STEEL Company of Canada's by-product coke oven plant in Hamilton, representing an expenditure of over \$3,000,000, has been completed and was inspected recently by a party of civic officials. Benzol is produced to the extent of 120,000 gallons a month, which will be sold for local consumption as a motor fuel.

## SWEEDISH SEPARATOR NEWS

W. Y. SCOLLARD, for several years with International Harvester Company, is now in charge of Peterborough territory for the Swedish Separator Company. Mr. Scollard has a wide experience as a separator salesman, having sold separators both as a local dealer, salesman and blockman.

\* \* \*

W. T. Ready, formerly salesman with Frost & Wood Co. at Smiths Falls, has recently joined the sales staff of the Swedish Separator Company.

\* \* \*

V. F. Lilly, special salesman for the Swedish Separator Company, has just returned from a trip through Eastern New York and States of Vermont and Maine. Mr. Lilly reports trade in separators picking up.

\* \* \*

S. A. Perry, formerly auditor for large South American concern, has been appointed cashier at Montreal office of Swedish Separator Company.

Aikenhead's

"The Sign of Better Service"

## MOSSBERG SOCKET WRENCH SET



MOSSBERG SOCKET WRENCH SET No. 14  
Patented  
"Completest" Socket Wrench Set

To give you a full socket wrench set with every tool unit of usefulness, is the reason for the No. 14 Socket Wrench Set. In the line of constant endeavor to improve the set, a double-end Offset Screw Driver takes the place of the old style screw driver bits, and the tools, formerly packed in the cover, have been placed in a tray.

You will appreciate the new No. "14." In wooden box, containing:

- 1 Mossberg Ratchet Socket Handle, No. 350.
- 1 Mossberg No. 330 "T" Handle.
- 1 Mossberg No. 320 Offset Socket Wrench handle.
- 1 Extension Bar, No. 351, 10 inches long.
- 1 Sterling No. 100 finest Nicked Pliers.
- 1 "Gripsall" Pipe Wrench, No. 470.
- 1 S. A. E. Double-end Wrench Set, full finish, five wrenches, ten openings.
- 1 Universal Joint.
- 3 Special Spark Plug Sockets, sizes 29-32 inch, 31-32 inch and 1 5-32 inches.
- 1 Double-end Offset Screw Driver.
- 1 Cotter Pin Extractor, No. 1, bright nickel plated.
- 23 sizes thoroughly hardened and Parker Rust Proof Hex. Sockets.
- 11 sizes thoroughly hardened and Parker Rust Proof Sq. Sockets.

Aikenhead Hardware Limited

Toronto - Canada

## BIRSELL CLOVER HULLERS

Best for Threshing,  
Hulling and  
Cleaning

Little Red or Common Clover Seed  
Big English or Mammoth Clover Seed  
Alsike Clover Seed  
Sweet Clover Seed



## THREE SIZES FOR CANADA

No. 2	Cylinders 27" x 32",	Capacity 3 to 5 bushels per hour,	Power Required 6 to 8 H. P.
No. 1	Cylinders 30" x 36",	Capacity 5 to 7 bushels per hour,	8 to 10 H. P.
No. 8	Cylinders 40" x 52",	Capacity 7 to 10 bushels per hour,	10 to 12 H. P.

WE HAVE A SIZE TO SUIT EVERY NEED

## ANN ARBOR HAY PRESSES

If in the market for a Hay Baler we can furnish in any size to meet your requirements. Write us or call and see us while in the city.

Birdsell Manufacturing Co.

Foot of George Street  
Toronto, Canada



## STORM VERTICAL BORING MILL

THIS mill is intended for automotive cylinder re boring, but its vertical design, it is claimed, makes it ideally suitable for boring and re boring large gears, tractor wheel hubs, heavy bushings, and rough castings of unusual dimensions. The sturdy pedestal body, the makers say, presents a most pleasingly clean cut exterior. It combines beauty and strength and possesses a rigidity that makes operation of the mill surprisingly quiet and vibration-free. It occupies a floor space 30 x 36 and stands 44 in. high. Its upper face is accurately surfaced and equipped with parallel sliding rails and an adjustable overhead clamp forms a horizontal bed on which cylinder blocks and heavier work may be readily mounted and handled by one person, unaided.

The pedestal body also houses the boring bar, with its driving, feed and regulating mechanisms, and insures protection to these moving parts. The upper and lower adjustable main bearings supporting the centered boring-bar are extremely liberal—8 and 6 in. long respectively—and are an integral part of the one-piece body casting. The carbon steel hollow boring-bar is bone-hardened and ground to size. The tempering process gives this 2 9-16 inch hollow bar an extreme strength and rigidity and renders it resistant to all wear.

Two boring-bar feeds are obtainable; 40 rev. per inch for general work and 8 rev. per inch for fast work. By means of step cone pulleys the boring speed may be suited to the feed and character of the work. The boring-bar is actuated by a heavy feed-screw and cut gears and has a travel of twenty inches. An automatic time-saving feature makes it possible to set the bar to stop and return to bottom at completion of the cut. Four self-centering Storm multiple-cutter adjustable type cutter heads with high speed steel cutters are furnished, affording a diametrical boring range of from 2 5-8 to 7 7-8 in. Special heads to 12 in. diameter can be had. It is manufactured by the Storm Manufacturing Company, Minneapolis, Minn.

## SAFETY PLOW HITCH

THE Parker safety plow hitch, which has been offered to the trade recently by the Parker Safety Hitch Co., St. Paul, Minn., is claimed by the manufacturers to be exclusively a concussion hitch. It does not depend upon spring pressure to release. The shock of a plow striking a stone or other serious obstruction in the ground, it is said, causes the release.

The spring is used to hold the top down and to assist in the releasing process when the shock comes. Only a part of the weight of the load is on the spring.

The hitch is made from cast steel, except the top, which is of spring steel, and has sufficient "give" in itself to release under the strain of a shock. The hitch has worked satisfactorily without a spring, but it takes a little bigger shock to release it without the spring. It has been found, the makers say, that the hitch will pull its load, no matter how heavy, with the spring on; and will undoubtedly give surer protection to the plowing equipment.

The hitch is made in various sizes to suit the requirements of any tractor and is made with a ring or clevis for attaching to the tractor.

## BENSON UNIVERSAL BATTERY CONNECTOR

THIS connector is designed for use on rental batteries so that they can be readily adapted to the different cable terminals found on the various cars. They are made in three sizes: No. 1-P fits the positive taper post, No. 1-N fits negative taper post, No. 1-S fits either positive or negative straight post. These connectors are made of bronze metal and are coated with lead.



Mobile Oiler Attached to Rear Springs

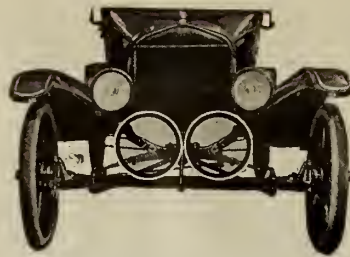

Mobile Oiler Attached to Front Springs



Benson Battery Connector



Mobile Spring Oiler

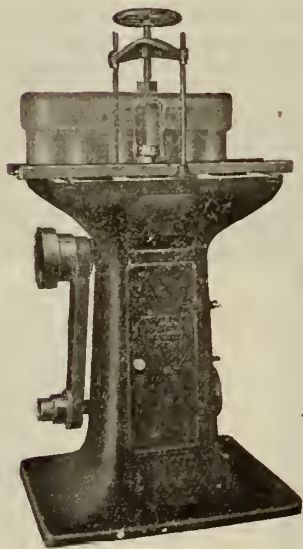

Storm Cylinder Boring Machine

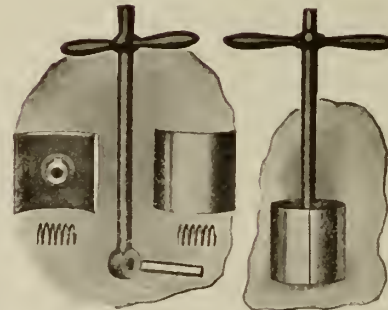

Clover Cylinder Lapping Tool

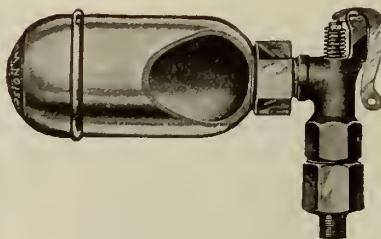

Buell Explosion Whistle



Parker Safety Plow Hitch

## MOBILE OILER FOR FORDS

MOBILE oilers for Fords are made of high-grade felt, reinforced by a strong spring. The oiler is dipped in oil and inserted between the channel frame and the top spring leaf at front and rear of the car. No tools are needed—the oiler can be inserted with the fingers.

Every deflection of the springs brings the oiler into play; a little oil is forced out and penetrates the spring leaves. The surplus is drawn back into the reservoir. Usually only two fillings are needed during the year.

The makers claim after the oiler is installed you can forget all about it and the springs will receive automatic and efficient lubrication. The makers are the Mobile Manufacturing Company, 820 South Tripp Ave., Chicago.

## GRINDING AND LAPPING COMPOUND

THE Clover grinding and lapping compound is for grinding valves and lapping piston rings and cylinders. It is manufactured by the Clover Mfg. Co., Norwalk, Conn., U.S.A., who say that it will, in a very short time, remove all carbon from valves and accurately reseat them. It can also be used for lapping piston rings into their grooves and into the cylinder, and will lap all score marks from the cylinder.

## BUELL EXPLOSION WHISTLE

THE Buell explosion whistle is a scientifically constructed warning device that combines the features of great simplicity and certainty of operation with a note of ultra warning value that appreciably lessens accidents. Screwing in place of a priming cup, the Buell utilizes the high explosion pressure of 200 or 300 pounds per square inch. On engines not equipped with priming cups the Buell is installed with a special spark plug. The tone of the Buell is clear and not at all inclined to screech or overtone. The operator can control the volume of sound, giving a light musical note or powerful compelling blast when an emergency requires quick action by a slight touch of the finger to control cord attached to steering column. There are two models, the Chime and the Single Tone. The Chime model is suitable for all cars, but is not recommended for use through spark plugs. The Single Tone, illustrated here, is also suitable for all sized cars and works satisfactorily through a special spark plug opening, as it requires but one-third the volume of the chime.

## ARMATURE TEST UNIT

THIS armature test unit is designed for testing short circuits or open circuits, and also grounds in any type of motor or generator armature. The unit is practically universal, inasmuch as it will take armatures ranging from 2 to 4 1/4 in. in diameter. For short circuit testing the unit is connected to a 110-volt alternating current, the armature mounted in the V and slowly turned by hand; at the same time a flat piece of steel is held over the armature and approximately 1-32 in. from it. If there is a short circuit in the winding or commutator, this blade will be attracted to the armature over the slot containing shorted coil. By making slot and tracing connection to the commutator end the test will indicate whether it is commutator or short within the coil. For ground testing an indicating lamp and a set of test points are provided permitting grounds to be located in the armature. Field coils, frames, assemblies and other parts of electrical units can also be tested in the same manner for location of grounds. An attachment plug and six feet of cable are furnished for connecting to lighting circuit. A snap on the front end disconnects the current from unit coil. It is made by the Service Products Co., Springfield, Ohio.



**IMPLEMENT DEMAND CAN BE STIMULATED**

THE old law of supply and demand, with which everyone is familiar, has been forgotten during the past four years. It appeared for a time that there was a never ending demand for all commodities and that prices could be advanced depending only upon the nerve of the manufacturer. Many manufacturers appeared to have the nerve, too. We are not saying that any particular industry profited, but we have our opinions.

Without offering any apology because we are in the implement industry or that this industry should be excused, or that it is a model of righteousness, we want to say most emphatically that this industry has been fair to the consumer.

B. F. Peek, speaking before the annual meeting of the National Implement and Vehicle Association, said that the average profit for the six years, 1913-1918, of the implement manufacturers was 6.51 per cent.; that the lowest profit for any concern was 4.07 per cent. in 1916, and the highest 9.86 per cent. in 1918. An average profit of 7.71 per cent. was the record of 1913.

These figures should convince anyone that the implement manufacturers were not profiteers and were not working a hardship on anyone.

At this particular time of the year the demand for farm implements, of course, is not large. No farmer buys a plow that is to be used four or five months hence. Very few farmers buy any implement or any other product except that they expect to use it immediately.

It is unfortunate that the idea that a "period of depression" exists is more or less prevalent in the minds of some and that it comes at this particular time of the year. If it were in the springtime when farmers were about ready to buy we doubt if it would have any effect upon their purchases.

We believe that demand can be stim-

ulated. For example, three years ago the demand for raisins amounted to one pound per capita. To-day that demand has increased to three pounds per capita. Advertising and sales effort established in our minds the fact that raisins are a food.

It is the duty of every business man to devote his energy to providing a market for the article he wishes to sell. Skillful marketing can be done by strengthening the demands of the trade. Every farmer wants to be successful and his income is more or less directly affected by the improved implements which are required on the farm. You can rest assured that the farmer will want what you have to sell more than he will want the money it requires to purchase it.

The business man who is a quitter and will stop active sales effort in order to wait for the demand to catch up with him will be lost by the wayside in business progress. As Curtis Johnson says, "You can't drive a nail with a sponge."—E. B. Dealers' Magazine.

**J. H. HISCOCKS PASSES**

J. H. HISCOCKS, since 1914 secretary of the Ontario Commercial Travellers' Association, died at his residence in London recently. He was born in Wingham and was in business there for some years. Later he joined the International Harvester Company at the London branch.

**INTERNATIONAL RAISES TRACTOR PRICES**

ADVANCES of \$100 each on the Titan 10-20 and I. H. C. 8-16 tractors have been announced by the International Harvester Co. Coincident is an increase of about 10 per cent. in the prices of gas engines. The heavy increase in the cost of materials, iron especially, as compared with prices for materials used in the 1920 product is cited as the reason for the advance.

**CARELESSNESS MEANS TROUBLE**

CARELESSNESS causes more trouble than any other one thing. Probably ninety-nine per cent. of all accidents are due, directly or indirectly, to somebody's carelessness.

It is difficult to understand why a man will spend several hundred dollars for a tractor or some other machine, and then, through sheer carelessness and indifference, proceed to run it without oil, cooling water, or with parts loose or out of adjustment, when he must realize that such treatment will cause damage if not utter ruin. Yet there are hundreds of cases where this very thing happens. In fact it seems to be almost an exception to find a tractor which is given first-class care in all respects.

A factory expert recently spent two days in visiting the tractors which his company had sold in a certain locality. There was a large number of these machines in use on farms in the neighborhood, and he went from farm to farm in an automobile, inspecting approximately thirty machines in the two days. The machines in question were equipped with an air-cleaner which was designed to remove dirt from the air by passing the air through water. The instruction book which went with each tractor, as well as instructions printed on the air cleaner itself, stated very plainly that the water reservoir in the cleaner should be kept filled with water.

Yet among all the machines which the expert visited in two days he found only one which had water in the air-cleaner.

This is just one of many examples which might be cited to show how the average tractor operator neglects his machine. And it is safe to say that a little later on, when the pistons, rings, and cylinder walls of those tractors are badly worn because of the dust which has been taken in through the air-cleaners with dry reservoirs, the owners will lay a large share of the

blame on the manufacturer, just as frequently happens when the wrong kind of oil has been used, or an engine has been overheated because the operator neglected to keep water in the cooling system. It is quite characteristic of a careless person to blame someone else for mishaps due to his own carelessness.—Tractor Farming.

**INTERESTING CATALOGUE**

THE Canadian Blower and Forge Co., Ltd., Kitchener, Ont., have issued a new catalogue, No. 19C, dealing with their varied line. This includes forges, blowers, exhausters, fans, drills, punches, shears, binding machines, tire setters.

Combination wood working machines, fan system apparatus for heating, ventilating, drying and mechanical draft, air washers, humidifiers, dehumidifiers, pumps, etc., etc., are also shown. This book contains 186 pages of real, live information to those interested in such lines.

**ALBERTA AUTO LICENSES**

PROVINCIAL Deputy Secretary Trowbridge announces that the total number of auto licenses sold this year in Alberta is 38,050, as compared with 34,000 last year. It was thought three months ago that the annual issue would reach the even 40,000 mark before the end of the present year, but the drop in grain prices is held as accountable for the slackening of auto purchasing during the fall.

**HAMILTON PLANT BUSY**

A DESPATCH from Hamilton stated that one of the busiest spots there is at the National Steel Car Co. This concern has 844 men on its payroll, exclusive of the office and sales departments. While not a few Hamilton manufacturing plants have begun to retrench to a moderate degree, this large concern has found it necessary to put on a night shift.

**"You're the Doctor, Bill"**

HOW much of your trade relies upon your judgment when they come to purchase automobile supplies? Quite a goodly number, we would suppose, for they have dealt with you a long time. So when you recommend a

**"HEXALL" Socket Wrench**

Trade Mark Reg. U. S. Patent Office

they naturally take it for granted that you are selling them the most dependable, most satisfactory socket wrench on the market.

This is their attitude: "You won't sell me something you wouldn't buy yourself, so if you say it's O.K., I'm satisfied. 'You're the Doctor, Bill'."

**Faith like that must be maintained.** When you take down a "HEXALL" Set from your shelf and hand it over the counter—you can look your man squarely in the eye, knowing that you are giving him the **best socket wrench in the world**—conceded as such by a constantly increasing number of motorists, motor-boat owners, aeroplane enthusiasts who find in "HEXALL" every requirement of the perfect socket wrench. Besides, it's guaranteed:

**"Break Any Sedgley Wrench and We Repair It--No Charge"**

The "HEXALL" Line—seven sets—a "HEXALL" for every need—carries an attractive profit; it is a consistent "repeater"—a distinct asset to any hardware or sporting goods store. **Be sure it's a "Hexall."**

Always keep a display of the "BABY" Hammerless Revolver on the counter and in the window. It's the smallest "death-dealer" on the market. Shoots six .22 caliber rimfire cartridges. Measures only four inches from muzzle to stock; weighs 6 oz.

Write for prices and discounts. Dealers reach your jobbers; jobbers reach us.

**R. F. SEDGLEY, Inc. Est. 1897**

2311-13-15 North 16th St., PHILADELPHIA, PA.

Canadian Distributors: Lamontagne, Limited, Montreal, Canada.

Harold F. Watson Co., Sole Agent, 208 Coristine Building, Montreal, Canada.

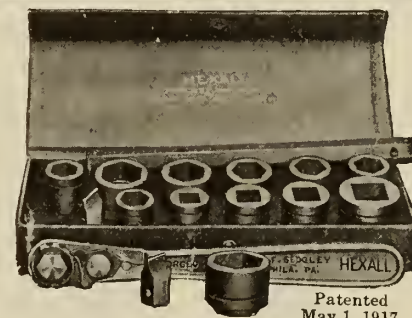

Patented May 1, 1917  
"HEXALL" Ratchet Socket Wrench No. 1—16 pcs.

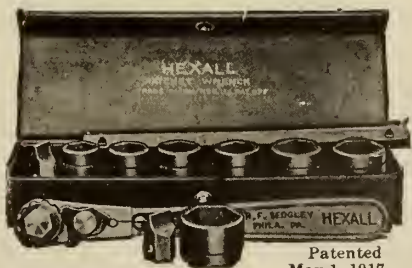

Patented May 1, 1917  
"HEXALL" Ratchet Socket Wrench No. 2—11 pcs.



Patented Dec. 31, 1918  
"HEXALL" Socket Wrench No. 5—8 pcs.

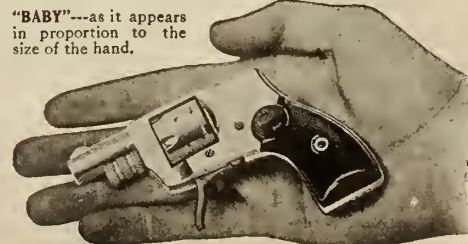

"BABY"—as it appears in proportion to the size of the hand.



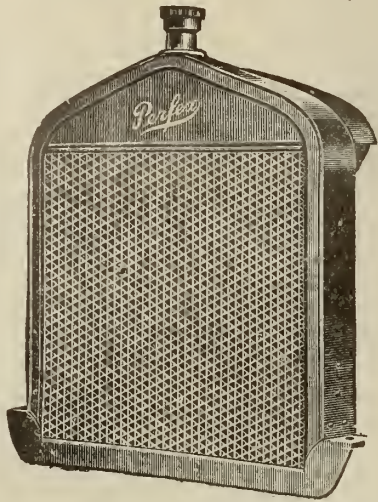

# PERFEX

*The Perfect Radiator*

Perflex radiators for Fords are a quality product embodying features that cannot be had in other radiators.

A patented spring bracket suspension and a real radiator core of great efficiency.

*The last word in Radiator construction*

Perflex Radiator Co., Racine, Wisconsin, U.S.A.

P. A. C. McINTYRE & COMPANY  
311 Confederation Life Building, Winnipeg  
Direct Representatives for  
Manitoba, Saskatchewan, Alberta and British Columbia

## WESTERN NOTES



### MANITOBA

WINNIPEG. — The Consolidated Motors, Ltd., will erect a new garage at a cost of \$80,000.

WINNIPEG.—The Fort Garry Motor Company, 501 Furby street, has secured the agency for Briscoe cars.

WINNIPEG.—A. W. Prugh, manager of the Gray Tractor Co. of Canada, spent some time in the territory with his dealers lately.

WINNIPEG.—The Royal Garage, 194 Edmonton St., has been appointed a sub-agency for the sale of Hudson, Essex, Studebaker and Gray-Dort cars by the Western Canada Motor Car Company.

BRANDON. — The Massey-Harris Company, Limited, has purchased the Gordon, McKay building at a cost of \$130,000, and adjoining buildings at a cost of \$10,000. The Brandon warehouse will be used as a distributing centre for that section of Western Canada.

WINNIPEG.—At the annual meeting of the Winnipeg Automobile Club held recently the following officers were elected for the ensuing year: President, S. M. Campbell; hon. president, F. E. H. Luke; first vice-president, C. L. McLaughlin; second vice-president, J. A. Banfield.

### SASKATCHEWAN

REGINA.—The Burd Ring Sales Co., Ltd., manufacturers of Burd piston rings, have opened a branch here.

ROCANVILLE.—J. A. Lockhart has taken over the implement business formerly conducted by Messrs. Kidd and Clements, Ltd.

INDIAN HEAD.—J. Blair, implement dealer, has taken a partner into his business. The firm name is now Blair and McLean.

REGINA.—B. Baker, manager of the Canada Tillsoil Farm Motors, Ltd., recently visited the company's Regina headquarters.

EYEBROW.—T. T. Turner, implement and automobile dealer, has commenced a garage repair business in connection with his other lines.

SWIFT CURRENT. — The Great West Implement Co., Ltd., had a big sale recently in all kinds of tires and tubes and automobile accessories.

ESTON.—The Excelsior Garage has installed a large generator for making acetylene gas. Oxy-acetylene welding will be done and all work guaranteed.

MAPLE CREEK.—Kells and Williscroft, automobile and tractor repairs, have dissolved partnership. H. A. Williscroft will continue the business.

ROCANVILLE. — The Rocanville Garage has been taken over by the General Motor Service Co. The new company will give a complete automobile and tractor repair service.

REGINA.—At the annual sales convention of the Sharples Separator Co. held at West Chester, Pa., recently the following members of the company's Regina office attended: W. R. Fulkerson, manager; and Messrs. Williams, Sleeman, and Grant, salesmen.

BATTLEFORD.—The city council at a recent meeting declared itself in

favor of petitioning the Provincial Government to allow the cities of the province to share in the revenue collected from automobile licenses. A resolution was passed authorizing the city clerk to communicate with other Saskatchewan cities with a view to forming a joint delegation to wait on the Government.

### ALBERTA

EDGERTON.—Messrs. Morrow and Clendennan have purchased the implement and hardware business formerly conducted by H. S. B. Wheeler.

EDMONTON.—The Alberta Dairy Supplies, Limited, distributors of milking machines and dairy implements, have increased their capital to \$300,000.

RED DEER.—The Mechanical Garage, formerly conducted by W. Irish, has been taken over by J. F. Goring, who will handle McLaughlin and Dodge cars and a full line of tires, accessories and parts.

### BRITISH COLUMBIA

VERNON.—The Finch-Patton Motor Company has opened a branch business in Vernon.

PENTICTON.—The Pacific Tractor Company of Vancouver has opened a branch business here.

COURTENAY.—Cliff Cameron has purchased a piece of property where he will erect a garage.

SALMON ARM.—D. C. Day has opened a garage here and will conduct a general automobile repair business.

VANCOUVER. — The Strathcona Garage has been purchased by F. Cheesman. He will handle automobiles, accessories and repairs.

COURTENAY.—A new garage has been opened by T. Weeks of Nanaimo. He has installed a machine shop and will handle all repairs.

VICTORIA.—The Shell Garage has been taken over by Messrs. H. Moore and H. Davis. They will handle the Mitchell and Nash cars.

LADYSMITH.—Ernie Eve, formerly with the Shell Garage, Limited, Victoria, has opened up a garage here. He will handle Nash cars and repairs.

KAMLOOPS.—F. P. Smith, formerly with the Ward Motor Company, has taken over the Central Garage, where he will conduct a general repair business.

VICTORIA.—A new garage has been opened at 847 Yates street by V. M. Rolfe, who will handle automobiles and repairs and conduct a Willard battery service station.

### QUEBEC

MONT JOLI.—The Mont Joli Automobile Club has announced its intention of joining the Quebec Provincial Motor League, and has elected delegates to attend the next general meeting of the provincial motor clubs.

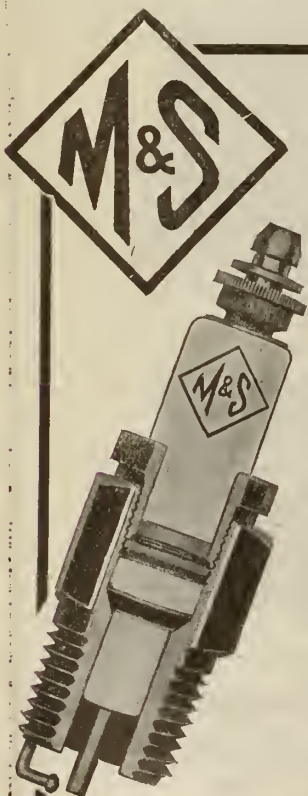

## The Plug with the HOTTER SPARK

The ball point of the "M & S" plug creates a larger and hotter spark, causing more complete combustion. This hot spark will give your car new life and more power.

The three-in-one terminal is adapted to any style ignition wiring. The high-grade chemically glazed porcelains are interchangeable — one porcelain fits all plugs.

DEALERS—The "M. & S." plug is standard equipment on the new Overland "4." Ask your jobber for them.

Machine & Stamping Co., Ltd.

1209 King Street West  
TORONTO  
Commercial Dept.  
Russell Motor Car Co., Limited

#### Models

- 500—½" Standard
- 501—¾" Standard
- 502—¾" Long
- 503—¾" Long with Chevrolet Terminal
- 506—½" Long
- 504—Regular Porcelain
- 505—Chevrolet Porcelain



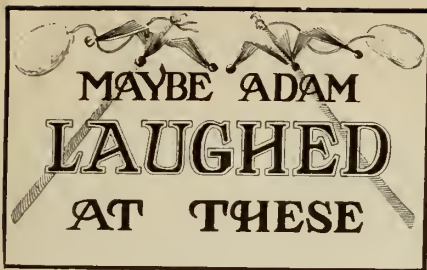

Traveling Salesman—"Learned them in college, I presume."  
Jed Hicksleigh—"No, he jes' kinda got ont a 'em readin' postal cards."—New York World.

\* \* \*

Joseph and Isaac went to hear Billy Sunday preach, and after service, as they were going home, Joseph said:

"Vell, Izaac, vat you t'ink of him?"

"I didn't like him," said Isaac. "Too much hell. It was hell, hell, hell all the time. And I don't believe there is any hell, Joseph."

"No hell?" asked Joseph, in amazement.

"No," answered his friend.

"Vell, then, Izaac," said Joseph, "if there is no hell, where is bizness gone?"

\* \* \*

A Medical Corps officer chanced upon a negro acquaintance of civil life one day in France.

"How do you like the army, Mose?" he asked.

"S'all right so far, cap'n," replied the negro, "but Ah don't know how I'm going to like it when dem Germans shoots at me."

"Don't worry about that," replied the officer. "All you have to do is zigzag." And he demonstrated.

The next time the two met, the negro was in a hospital.

"What's the matter with you, Mose?" asked the officer.

"Ah ain't sure, cap'n, but Ah think I must have been ziggin' 'bout the time Ah oughta been zaggin'."—American Legion Weekly.

\* \* \*

First Doctor—"Did you have a large flue practice during the epidemic?"

Second Doctor—"About a hundred gallons, I guess. And you?"

First Doctor—"Oh, two or three hundred cases."—Cartoons.

\* \* \*

An old lady, after waiting in a confectionery store for about ten minutes, grew grossly impatient at the lack of service.

Finally she rapped sharply on the counter.

"Here, young lady," she called, "who waits on the nuts?"—Everybody's Magazine.

\* \* \*

Bore—"Yes, I don't know how it is, but I feel thoroughly wound up tonight."

Hostess—"How very strange! And yet you don't seem to go."—London Tit-Bits.

\* \* \*

"Oh, doctor, tell me, quick!" moaned the fair patient, clasping her lap-dog and convulsively nibbling a thousand-dollar cheque. "How sick am I? Is it California, Florida or Europe?"—Seattle Post-Intelligencer.

\* \* \*

Every rose has its thorn, not to mention the dog-gone little bugs.—Toledo Blade.

\* \* \*

She was what Mayfair would call "inclined to embonpoint," and White-chapel, "a bloomin' whopper!" Also, she was straphanging in the tramcar.

At the first lurch the strap gave way and she landed in the meek man's lap. She scrambled off and grasped the rail. The rail came down with a crash.

The meek man carefully sorted himself out, and rose.

"Perhaps, ma'am," he murmured, "you'd like my seat?"

"You are very kind, sir!" she gasped, breathlessly.

"Not at all, ma'am!" he responded, grimly. "It ain't kindness; it's self-defense!"—London Tit-Bits.

"Have you seen May?"

"May who?"

"Why, Mayonnaise."

"No, she is dressing, and won't let-tuce."—Co-Operator.

\* \* \*

"Ma, do cows and bees go to heaven?"

"Mercy, child, what a question! Why?"

"'Cause if they don't, the milk and honey the preacher said was up there must be all canned stuff."—E. B. Dealers' Magazine.

\* \* \*

"A woman came into the hospital the other day and she was so cross-eyed that the tears ran down her back."

"You couldn't do anything for her, could you?"

"Yes, indeed; we treated her for bacteria."—Case Eagle.

\* \* \*

"If I cut a beefsteak in two," asked the teacher, "and then cut the halves in two, what do I get?"

"Quarters," returned the boy.

"Good. And then again?"

"Eighths."

"Correct. Again?"

"Sixteenths."

"Exactly. And what then?"

"Thirty-seconds."

"And once more?"

"Hamburger," cried the boy, impatiently.—Case Eagle.

\* \* \*

A bricklayer was laying bricks on the third story of an unfinished house, and unfortunately dropped a brick on the head of a colored man who was mixing mortar down below.

The bricklayer, his heart in his mouth, craned over the parapet. He thought he had killed the poor colored man. But the latter looked up at him with a good-natured and forgiving grin.

"Hey, vat you doin', white man?" he shouted. "You made me bite mah tongue."—Case Eagle.

\* \* \*

A negro chauffeur of Boston was haled into the court for running down a man.

"Yo' honor," said the negro, "I did de bes' I could to warn de gennulman; I tried to blow de horn, but it wouldn't work."

"Then," said the judge, "why didn't you slow up rather than run over him?"

A light seemed to dawn on the prisoner, who finally said, "Why, judge, dat's one on me, ain't it? I never thought of dat."

\* \* \*

The young lady was taking the church census, and a tall young man with a clerical appearance had just requested her to step inside, as they had sickness in the house and didn't like to leave the door ajar. Influenza prevailed in the neighborhood, and the young woman was cautious.

"It isn't anything contagious, I hope?" she queried suspiciously.

"Twins, ma'am," was the reply.

The young lady "flu."

\* \* \*

Traveling Salesman—"Whom do you consider the smartest man in the village?"

Jed Hicksleigh—"Postmaster. He's the smartest feller hereabouts—speaks six languages."

# Sell "Spedolene"

## --the all-year lubricant

Ask for particulars of "Spedolene" and our selling plan.



**SPEDOLENE REFINING & MANUFACTURING CO., LIMITED**

MONTREAL

A specially compounded lubricant that keeps new gears running smooth and true and gives old gears a new lease of life. Prolongs the life of motor cars, trucks and tractors by preventing wear and tear on transmissions, differentials, Universal joints, bearings, etc. Unaffected by climatic changes, will not corrode gears, or bearings, eliminates frictional wear.

Makes friends quickly, and keeps them. Priced to give you a nice profit.

## National Advertising and Household Budgets

We are hearing a lot these days about Budgets. They affect every household in Canada. They call for intelligent and scientific distribution of expenditures. They call for the purchase of merchandise of dependable and uniform high quality at lowest possible prices.

Canadian housewives are greatly interested in Budgets—in keeping household expenses at low level—without sacrificing the quality of the food they eat, the clothes they wear, the musical instruments they use, and the household furnishings and labor-saving devices they buy.

National advertising takes the guesswork out of buying. It is the advertiser's expression of faith in his merchandise. It is a guarantee of quality. Advertising keeps the quality up. Inferior merchandise cannot masquerade in the quality clothes of advertising. National advertising increases demand and production and lowers the selling price to you.

Advertisements show you how to buy most efficiently and economically. Read the advertisements.



**ELECTRION FARM ELECTRIC PLANT**

A 32-volt farm electric plant which combines utility and attractiveness is being made by the Lindermen Steel & Machine Co., Dayton, Ohio. An 110-volt outfit also is made.

In general appearance it is very simply constructed. Every unit, except the batteries, the makers claim, is assembled in a very attractive cabinet enameled in peacock blue. The batteries are grouped in a wooden case which likewise presents a clean and attractive appearance. It excludes dirt

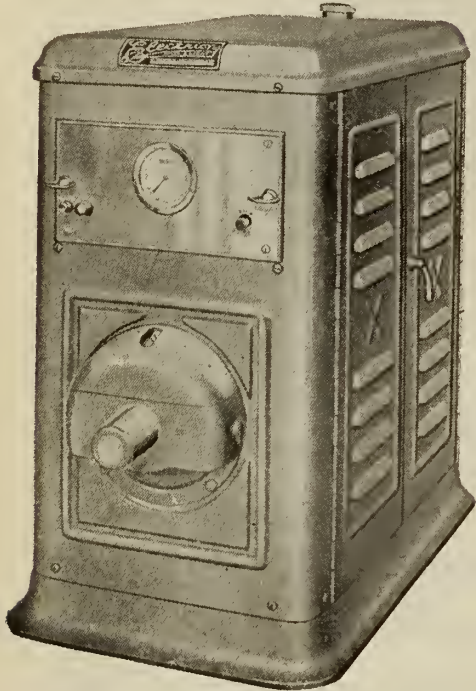

Compact cabinet in which the units of the Electrion Farm Electric Plant are housed. All the units, except the batteries, are contained in this metal cabinet which is enameled a rich peacock blue.

A moisture and provides practically complete protection for the batteries. The 32-volt unit is semi-automatic in operation. By pushing a button it starts, and when the battery is fully charged the engine stops automatically. Also, when the battery becomes about three-fourths discharged it is automatically cut off from the line to prevent damage to it through exhaustion.

There is an automatic circuit-breaker which disconnects the lighting circuit from both the generator and the battery, in the event of a short or an overloaded circuit. This protection obtains whether the plant is running or idle.

The semi-automatic outfit can be converted into a full-automatic outfit at any time simply by removing the control case and putting in a control case of the type used in the full-automatic plant.

All the vital electrical apparatus of the Electrion plant is centralized in one removable unit. This is the control case. This unit is at the upper part of the cabinet face and slides in and out of piston just like a drawer in a desk. Any trouble in the special electrical part of the plant is centered in the case.

The Electrion plant is equipped with an electromagnetic governor which acts on the throttle to keep the engine running at the proper constant speed regardless of variations in load due to different current demands.

Fuel is fed to the engine of the Electrion through a carburetor, which is very simple in construction. There is no float or float valve. There is no float chamber or air valve. There is no spring. The only movable part is a needle valve which can be removed, it is said, without permitting any of the fuel to run out. The air for the fuel is taken through the crank-case breather and over the top of the cylinder head to be pre-heated before entering the carburetor.

The engine is cooled by an automobile-type radiator and fan. The fan can be adjusted to take up slack in

the belt. To protect the plant against damage, should the cooling water reach a low level, there is an automatic cut-out in the form of a float-valve operating in a water column just back of, and in connection with, the radiator. When the water reaches a low point this valve grounds the magneto.

The gasoline tank for the Electrion is in the base of the cabinet. It has a capacity for 2 1/4 gal.

Ignition is provided by a Dixie high-tension magneto. Lubrication is very simple. There is only one place where oil is applied. A sight oil-gauge warns when oil is needed. There is a large grease cup for lubricating the fan bearing. Engine lubrication is by splash.

The engine has a single, vertical cylinder with a bore and stroke of 2 3/8 in. and 3 in., respectively. It is controlled to 1,600 r.p.m. Valves are nickel-steel. The camshaft is drop-forged, machined, heat-treated and ground. All the parts are made of high-grade material finished to close limits. The main bearings are over-size S. K. F. self-aligning, double row.

For power take-off, a pulley can be attached. This is not provided as regular equipment, but can be obtained, if desired.

A compound-wound generator is used. One winding charges the battery in proportion to its charged condition, providing a lower rate of charge as the voltage of the battery increases. The other winding is a compensating provision, which causes the generator to furnish additional current for the line as the load increases. Thus a sudden demand for a large supply of current causes only a small drop in the voltage, and vice versa. It is claimed that no reversal of the generator polarity can occur. The brush holders are non-adjustable. The brushes cannot be

shifted from their proper position and, barring accident, will last indefinitely without attention, according to the maker.

**Specifications of 32-Volt Electrion**

Capacity	100 watts
Number of 20-watt lamps	50
Lamp voltage	32
Make of engine	Own
Number of cylinders	1
Horsepower	2 1/2
Fuel	G or K
Generator drive	Direct
Make of Generator	Own
Height of Electrion	29 in.
Width	16 in.
Length	28 in.
Net weight	450 lbs.
Shipping weight	550 lbs.

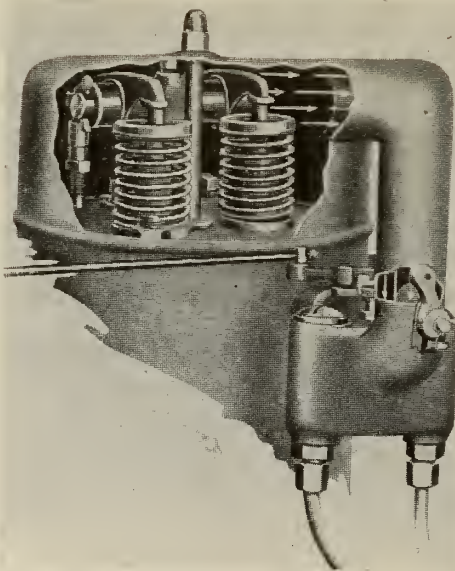

The motor of the "Electrion" is the valve-in-head type and follows the most advanced engineering practise.

**NEW AUTO SIGNAL LIGHT**

It is reported that J. A. White, of Galt, Ontario, has invented an auto signal lamp which can be operated by the driver and which shows a red light with an arrow to indicate the corner the car intends to turn. It has been

tested and proved satisfactory, removing one of the difficulties of night traffic in urban streets. Patents have

been applied for in Canada, United States, England, Australia and New Zealand.

**Enforce Anti-Glare Law**

Before Motorists in Canada Can Secure a 1921 License They Must Have Their Cars Equipped With Approved Anti-Glare Devices

THE officials of the Highways Departments of Ontario have issued a statement to the effect that the enforcement of the recently authorized regulation regarding headlights on motor vehicles will come simultaneously with the issuance of motor licenses for the year 1921. Before any owner of a motor vehicle can secure a 1921 license he will be obliged to answer on the application form whether or not his vehicle is equipped with an approved non-glaring headlight device, and if so he must give the name of the device he is using.

By this method the Motor Vehicles Department at the Parliament Buildings will have a record of every car owner in this province who has equipped his car for glare elimination. Since a great deal of investigation and publicity has been given to non-glare lenses by the Highways Department this year, it is most unlikely that many motorists in Ontario will wish to admit to the Government that they have not an approved device on their car when applying for next year's license.

The Act with amendments now reads as follows:

"It shall be unlawful to carry on a motor vehicle any lighting device of over four candle power, equipped with a reflector, unless the same shall be so designed, deflected or arranged that no portion of the parallel beam of reflected light, when measured seventy-five feet or more ahead of the lamp, shall rise above forty-two inches from the level surface on which the vehicle stands."

Dealing with devices for glare elimination, a further section says: "Any device for the elimination of glare, approved by the Minister of Public Works and Highways, when in proper adjustment and having a lamp of candle power not in excess of that authorized by the minister for such device, shall be held to be in conformity with the next preceding subsection."

A list of the approved devices has already been published in M. T. I. and any additions from time to time will be mentioned.

**Ontario Motor License Fee Increased**

AN increase in the license fee for automobiles in Ontario has been made and the additional revenue is to be used for improving roadways. A big road program is promised next year, as the Highways Department will have about \$750,000 more to work on. The revenue this year from auto licenses amounted to over two million dollars.

The greater part of the auto-owning public will be affected most by the first change, which increases the fee on passenger cars of not more than 25 horse-power, with not more than four cylinders, from \$10 to \$13; cars of the same horse-power with six cylinders, \$15; eight to twelve cylinders, \$20; cars of from 25 to 35 horse-power, with four cylinders, \$15, which is the same as before; 25 to 35 horse-power, with six cylinders, \$20; eight to twelve cylinders, \$25; cars with from 35 to 50 horse-power, four cylinders, \$20; six cylinders, \$30; eight to twelve cylinders, \$35; over 50 horse-power, four cylinders, \$30; six cylinders, \$35; eight to twelve cylinders, \$40.

On the smallest truck the new fee is \$13 instead of \$10. On trucks over two tons and not above eight, the new fee is \$6 per ton instead of \$5. On electric passenger cars the new fee is \$15 instead of \$10. Passenger busses are hereafter classed as commercial cars, and will pay on tonnage and horse-power, each passenger space being rated at 150 pounds.

Another feature is the introduction of a license fee for "trailers." On a small trailer the fee is \$2; on a trailer over one ton, and not more than two tons' capacity, \$5, and on trailers over two tons \$3 a ton.

The fees for a dealer and manufacturer in commercial cars are increased slightly, while the fee for license to deal in passenger cars remains the same. There is also a fee required when passenger cars are converted into commercial cars. The owner must pay the difference between the passenger license cost and the commercial car cost. The fee for transfer of license has been increased from \$1 to \$2. The cost of transit marker is increased from 25 to 50 cents.

This is the first time the number of cylinders in auto engines has been considered in making of license fees.

The table below gives an idea of how the new motor vehicles schedule will affect the licenses for some of the different makes of cars next year. It will be noticed that the number of cylinders and the horse-power are the factors in determining the new rates.

Name	Model	No. Cylinders	H.P., R.A.C.	Old fee, 1920	New fee, 1921
Ford	.....	4	22.5	\$10.00	\$13.00
Chevrolet	490	4	20.6	10.00	13.00
Chevrolet	B.G.	4	20.6	10.00	13.00
Gray-Dort	.....	4	19.6	10.00	13.00
Dodge	.....	4	24.0	10.00	13.00
Maxwell	.....	4	21.0	10.00	13.00
Overland	Four	4	18.2	10.00	13.00
Overland	Knight	4	21.0	10.00	13.00
Allen	.....	4	19.6	10.00	13.00
Essex	.....	4	18.2	10.00	13.00
Hupmobile	.....	4	16.9	10.00	13.00
McLaughlin	Small	6	18.2	10.00	15.00
Oldsmobile	.....	6	18.2	10.00	15.00
Reo	.....	6	24.3	10.00	15.00
Studebaker	Little	6	23.4	10.00	15.00
Cleveland	.....	6	21.6	10.00	15.00
Liberty	.....	6	23.4	10.00	15.00
McLaughlin	6-45	6	27.2	15.00	20.00
Nash	.....	6	25.3	15.00	20.00
Franklin	.....	6	25.3	15.00	20.00
Scripps-Booth	.....	8	24.6	10.00	20.00
Studebaker	Special	6	29.4	15.00	20.00
Chalmers	.....	6	25.3	15.00	20.00
Chandler	.....	6	29.4	15.00	20.00
Columbia	.....	6	25.3	15.00	20.00
Haynes	.....	6	29.4	15.00	20.00
Hudson	Super	6	29.4	15.00	20.00
Lexington	.....	6	25.3	15.00	20.00
Paige	.....	6	29.4	15.00	20.00
Winton	.....	6	33.7	15.00	20.00
Cadillac	.....	8	31.2	15.00	25.00
Oldsmobile	.....	8	26.4	15.00	25.00
Studebaker	Big	6	36.0	25.00	30.00
Peerless	.....	8	33.8	15.00	25.00
Standard	.....	8	33.8	15.00	25.00
Pierce-Arrow	38	6	38.4	25.00	30.00
Pierce-Arrow	48	6	48.6	25.00	30.00
Cole	.....	8	39.2	25.00	35.00
Packard	12	12	43.2	25.00	35.00



**HOW AUTO PRICES ARE AFFECTING THE WEST**

Continued from page 15

is by no means thirty per cent. here. Moreover, it may not apply on the surplus lines already carried. But suppose it does. There is duty, freight, sales tax, all to go on the self-driven vehicle, from the time it leaves the assembly floor till it hits the country road. The customer wonders who is making all the money. Somebody profiteering he immediately concludes, having heard and read so much about profiteering that he counts on it as his first weapon of defence, or offence as the case may be. But it must be remembered that about sixty per cent. addition to the factory price is unavoidable, and profits no one engaged in the disposition of the car.

"I just figured the other day," said the agent, "that the Government gets \$130 more out of one of our cars than the manufacturer, wholesaler and myself put together."

When this vast addition to the original price of the car is tacked on the matter of a fluctuation, though still a factor, is lessened considerably. Auto men claim that the automobile is not a luxury and that the tax is therefore not entirely just. Be that as it may, the tax is there, and every man who buys a car is paying in much of the fruits of his toil to the federal treasury.

One thing that would make about a thirty per cent. difference in auto business here and throughout the prairie west is the adjustment of the disparity which exists between the standard wagon width and the width of sleighs. Movements have been started in Saskatoon and elsewhere to standardize the width of winter and summer vehicles, thus making both wheel and runner traffic possible during the cold months. These movements, sad to say, have been well meant, but for some reason all have collapsed. At the same time their logic cannot be denied. Snow lies on the ground from four to five months and during that time to negotiate a car on the average country road is approximately impossible. Credit must therefore be given the Board of Trade and other organizations that have backed, even if only temporarily, a campaign for vehicular readjustment.

**Faith in Future**

It appears, on the face of it, a rather complicated business, this automobile element, yet it is regulated by the law of demand. Dealers are generally reticent; they are unwilling, as a rule, to voice their inner convictions at the present, when the following day might develop a direct opposite to the analysis of to-day. But the majority of them appear to be hopeful, to have genuine faith in the near future. The present is such a battered period that the drop in prices has been almost a setback. The fact that some cars have been reduced in price, while others are not, has helped to raise doubt in the minds of the prospective buyers.

It is impossible to say exactly what would have been the effect of dropping prices had other things been equal. Many claim the sales curve would immediately have been upward. Second-hand dealers granting that say their business would have swelled in proportion. Had the price reductions come in the spring they would have been followed by a considerable boom. As it is, had the war-time prices of wheat held, cars would have moved faster this fall. It will be interesting to see what principles the dealers apply to turn the trick, for there are no spent forces in this business.

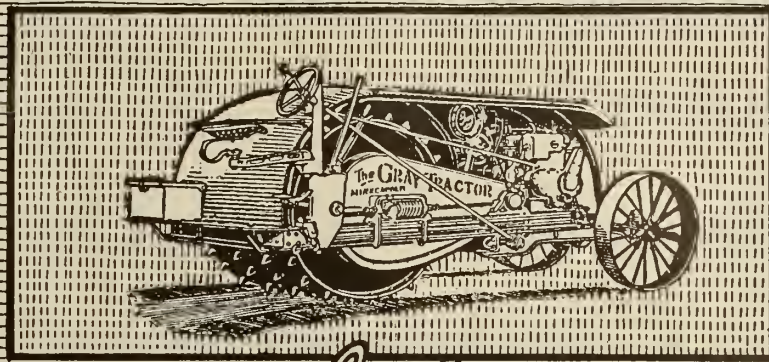

*Gray*

**Every Owner a Booster**

Wherever the Gray Tractor has been used, it is well spoken of.

It has an enviable reputation for perfect work and long service, that has been well earned by its consistent performance.

Following are some of the points of excellence that account for the satisfaction of all users of the Gray Tractor:

The Wide Drive Drum is a great asset. It crushes weeds and all trash flat ahead of the plows. It distributes the weight and assures perfect traction, even under unusual conditions.

sion with shafts running on Hyatt roller bearings, three point suspension frame, dust-proof construction with all working parts enclosed, running in an oil bath. The four-cylinder Waukesha motor is built for heavy work, and the equipment for lubrication, cooling and ignition are chosen for their individual excellence.

Other features are—the direct drive, no bevel gears, no differential, straight spur gear transmis-

Now is the time to get full particulars and make a thorough investigation of the Gray. Full details sent upon request.

**Gray Tractor Co. of Canada Limited**  
307-9 Electric Railway Chambers, Winnipeg

*Western Distributors:*

Morton & Lief Co., Ltd., C. Waring & Co., The Tractor Co., Ltd.,  
Calgary, Alta. Moose Jaw, Sask. Saskatoon, Sask.

**GRAY TRACTOR**  
**WITH THE**  
**WIDE DRIVE DRUM**

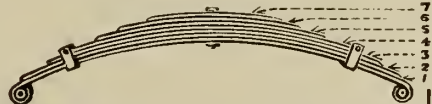

**AUTOMOBILE SPRINGS**

**The Guelph Spring and Axle Co.**

Guelph - Ontario  
Manufacture

**AUTO SPRINGS**  
**ALL KINDS**  
**HIGHEST QUALITY**

**PATENT FOR SALE**

I. E. Tatun, titular to Canadian Patent No. 202053, dated July 20th, 1920, relating to a clamp as used in connection with automobile and truck anti-skid chains, wishes to dispose of his full rights and privileges in Canada. For further particulars, apply to  
**ADRIAN A. ST. LAURENT, I. E., Patent Broker,**  
75 Stewart St., Ottawa.

**Keeping Tab on Conditions**

During the unsettled conditions of to-day it is necessary to watch the markets and the trade news very carefully.

An order for Press Clippings will bring to your desk each day the particular news you want, culled from the newspapers of Canada. You are kept posted right up to the minute and there is no better time than the present to make use of our service.

SUBSCRIBE TO-DAY

**Canadian Press Clipping Service**  
143-153 University Ave., Toronto



# National Motor Show of Eastern Canada

Held in the

## "MOTORDROME"

AS THE

—1921—

# Montreal Motor Show

January 22nd to 29th,  
inclusive

Under the Auspices of

The  
Montreal Automobile Trade  
Association, Limited  
MOTORDROME BUILDING

TEL. EAST 2566

228 Sherbrooke Street East  
MONTREAL

VICTOR LEVESQUE,  
Show Manager

ADELSTAN LEVESQUE  
Active Secretary

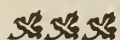

The Biggest and Best Auto-  
mobile and Accessory  
Show Ever Held  
in Canada.

## Dairy and Household Supplies

### LIGHTING PLANTS AND POWER WASHERS

By G. R. DONALDSON

THE dictionary defines the word "specialty" as something not commonly bought and used, and a "staple" as "an article of absolute necessity." In other words, specialties have to be sold. Staples are bought.

In exactly the same way that the typewriter, the sewing machine, the automobile, and other specialties of a few years ago are practically staple articles of commerce to-day, the farm lighting outfit is fast becoming a staple article of equipment on Canadian farms. In making it so dealers are offered a wonderful opportunity.

The typewriter and sewing machine having passed through the initial stages of development proves that their greatest value to dealers comes after they are developed, although the proportionate profits on each sale are reduced. But to a few dealers who do the missionary work while the specialty is first being merchandized goes the largest profit on each sale in return for his salesmanship.

There are a million and a half homes in Canada. Six hundred thousand of these are equipped with electricity. The remaining nine hundred thousand offer the manufacturers of Canada much too extensive a buying field for the number of really active dealers who understand the possibilities.

Every home that is not now equipped with electricity can be equipped with a farm lighting outfit. It only waits for dealers to make an intelligent sales effort and this specialty will become eventually a "staple" for every farm. The dealer with vision is the one who is cashing in on the demand already created by manufacturers' advertising and filling this demand with profit to themselves.

The electric clothes washer is a very recent development. In a very few years it has pushed itself forward until it is now the recognized leader of electric household appliances. It has gained this place because the women of to-day and particularly the women on the farm realize that a life of household slavery is not necessary. Electricity can relieve them of the drudgery that has taken so much out of the lives of Canadian women up to this time. Washing is acknowledged to be the worst enemy to home happiness. Its back-breaking strain, the littered, water-covered floor, the steam-filled kitchen are eliminated by the use of an electric clothes washer.

The farm lighting outfit was so named because the lighting of a home was at that time considered the greatest work that electricity could do. As a matter of fact, there are many other uses for electricity that are of even greater importance to the farmer and his wife.

Dealers must realize the work that electricity can be made to do for the farmer's wife and use this as their main selling argument.

Free the farmer's wife from churning, from pumping water, from the daily cleaning of lamps and lanterns, and more important than all of these, from the drudgery of keeping her family supplied with clean linen, and a dealer goes a long way in reaping the generous profits allowed by the manufacturers in the introduction of these farm lighting outfits.

SWEDISH SEPARATOR COMPANY  
COMMENCING only a year ago with operations principally in the Province of Ontario the Swedish Separator Company has built up a very successful separator organization.

The Montreal office now handles in addition to all Eastern Canada, the States of New York, Maine, Massachusetts, New Hampshire, Vermont, Connecticut and Rhode Island, and reports a very successful business from each province and state during the first year's operation.

The Viking cream separator, chief product of this company, has been sold in Canada for ten years, but previous to this last year had been sold through jobbers. The first Viking separators sold in this country, while crude in design and plainly gotten up, are still in use to-day, giving the user the best of satisfaction and service.

It is reported that the company intends increasing their sales force materially during the coming year, and undoubtedly will make itself felt in the separator trade.

### PERFECTION LIGHTING PLANT

THE Perfection Model Sar 1½ K. W. electric lighting plant, manufactured by the Perfection Storage Battery Co., Chicago, is a compact, powerful, and smooth-running unit. The engine develops 4 horse-power and is cooled with a radiator and sirocco fan. The makers claim that this plant will carry 70 16-ounce power lights from the generator indefinitely. The plant is designed to operate, if desired, a cream separator or milking machine or any other heavy power-consuming device without overloading. Many of the parts used in construction are Ford parts.

The engine is of the four-cycle, water-cooled "L" type, developing four-brake horse-power at the pulley. The cylinder is 3¾-in. bore by 4-in. stroke. The crankshaft is of drop-

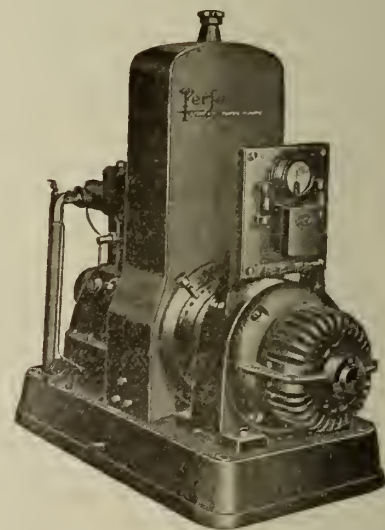

Perfection Electric Light Plant

forged steel 1¾-in. x 3-in. New Departure ball bearings are used on the crank shaft and at the generator end. Lubrication is provided by the constant level splash oiling system. The generator is a 1,500 watts, 1,150 r.p.m. normal speed, ball bearing, guaranteed by the makers against defective workmanship and material for one year. The generator is connected directly to the crankshaft, thus eliminating belt losses.

The switchboard is bolted to the top of the generator. The board is made of slate and equipped with a zero centre ammeter registering charge and discharge of battery; an automatic cut-in and cut-out switch for generator circuit; automatic stop relay to stop the engine when the battery is fully charged, or being charged at a high injurious rate; combination engine cranking and ignition switch; generator and light fuses.



# “When I sell a De Laval I have made a friend”—*W. G. Stewart*



*(Extract from letter)*

“Since holding the De Laval Agency Contract I have found the De Laval Separators very easy to sell, as I find that most of the prospective buyers are disposed in their favor when I canvass them. In fact, some prospective buyers have come into my store ready to buy ‘that De Laval Separator’ I wrote to them about.

“This shows that the follow-up system works well and many times has the sale all ready to close when the agent meets the prospect. The Users’ Signs, too, do their work and help very much to increase sales.

“I find the De Laval Agency both profitable and pleasant work, as when I have made a sale I have made a friend.”

W. G. STEWART,  
Hagersville, Ont.



There is no better time than right now to send in an application for a De Laval contract. There is more profitable cream separator business with the De Laval than with any other separator.

**THE DE LAVAL COMPANY, LTD.**  
MONTREAL      PETERBORO      WINNIPEG      VANCOUVER

50,000 Branches and Local Agencies the World Over



# CANADIAN Motor, Tractor and Implement Trade Journal BUYERS DIRECTORY

This directory will help you with your buying and your planning. The advertisers listed here are thoroughly reliable and leaders in their respective fields. They are looking for live, wide-awake representatives. Study their advertisements carefully because they contain valuable information which will dovetail with your plans. We are glad to go to the trouble of arranging this list—to make it easy for you to select new lines. If it so happens that what you want is not here, write us, and we will tell you where to get it.

- ACCESSORIES**  
Montreal Motor Show, Montreal, Que.  
Canadian General Electric Co., Toronto.  
Canadian Car & Foundry Co., Montreal, Que.  
Guelph Spring & Axle Co., Guelph.  
Apollo Plug Mfg. Co., Birmingham, Eng.  
R. F. Sedgley, Inc., Philadelphia, Pa.  
McCord Mfg. Co., Walkerville, Ont.  
The Canadian Raybestos Co., Peterborough, Ont.  
Aikenhead Hardware Co., Toronto.  
Lamontagne, Ltd., Montreal.  
Perfex Radiator Co., Racine, Wis.
- AUTOMOBILE BUMPERS**
- AUTOMOBILE CHAINS**
- AUTOMOBILE JACKS**
- AUTOMOBILE MIRRORS**
- BARN EQUIPMENT**
- BEAN MACHINERY**  
John Deere Mfg. Co., Welland, Ont.
- BEEF MACHINERY**  
International Harvester Co., of Can., Ltd., Hamilton, Ont.  
John Deere Mfg. Co., Welland, Ont.
- BEARINGS**
- BINDERS**  
The Frost & Wood Co., Ltd., Smiths Falls, Ont.  
International Harvester Co., of Can., Ltd., Hamilton, Ont.
- BELTING**
- BREAK LINING**  
The Canadian Raybestos Co., Peterborough, Ont.
- BATTERIES**
- CARRIAGES**  
Cockshutt Plow Co., Brantford, Ont.
- CREAM SEPARATORS**  
De Laval Co., Ltd., Peterboro, Ont.  
International Harvester Co., of Can., Ltd., Hamilton, Ont.  
R. A. Lister Co. (Canada), Ltd., Toronto
- CEMENT MIXERS**
- CASTINGS**  
Joliette Castings & Forgings Ltd., Montreal and Joliette, Que.
- CORN HARVESTERS**  
Cockshutt Plow Co., Brantford, Ont.  
International Harvester Co., of Can., Ltd., Hamilton, Ont.
- CORN MACHINERY**  
International Harvester Co., of Can., Ltd., Hamilton, Ont.  
John Deere Mfg. Co., Welland, Ont.
- CULTIVATORS**  
Cockshutt Plow Co., Brantford, Ont.  
John Deere Mfg. Co., Welland, Ont.  
The Frost & Wood Co., Ltd., Smiths Falls, Ont.  
International Harvester Co., of Can., Ltd., Hamilton, Ont.
- CUTTERS**  
Butterfield & Co., Inc., Rock Island, Q.
- DAIRY SUPPLIES**  
International Harvester Co., of Can., Ltd., Hamilton, Ont.  
R. A. Lister Co. (Canada), Ltd., Toronto  
DeLaval Dairy Supply Co., Peterboro.
- DIES**  
Butterfield & Co., Inc., Rock Island, Q.
- DISCS**
- DITCHING MACHINES**
- DRILLS, TWIST**  
Butterfield & Co., Inc., Rock Island, Q.
- DRILLS, GRAIN**  
Cockshutt Plow Co., Brantford, Ont.  
International Harvester Co., of Can., Ltd., Hamilton, Ont.  
John Deere Mfg. Co., Welland, Ont.  
The Frost & Wood Co., Ltd., Smiths Falls, Ont.
- ELECTRICAL EQUIPMENT**  
Can. General Electric Co., Ltd., Toronto.
- ENGINES**  
Gilson Mfg. Co., Ltd., Guelph, Ont.  
International Harvester Co., of Can., Ltd., Hamilton, Ont.  
John Deere Mfg. Co., Welland, Ont.  
The Frost & Wood Co., Ltd., Smiths Falls, Ont.  
R. A. Lister Co. (Canada), Ltd., Toronto  
Rapid Tool & Machine Co., Lachine, Que.
- ENSILAGE CUTTERS**  
Gilson Mfg. Co., Guelph, Ont.  
International Harvester Co., of Can., Ltd., Hamilton, Ont.
- FEEDERS**  
John Deere Mfg. Co., Welland, Ont.
- FARM MACHINERY**  
Cockshutt Plow Co., Brantford, Ont.  
John Deere Mfg. Co., Welland, Ont.  
International Harvester Co., of Can., Ltd., Hamilton, Ont.  
The Frost & Wood Co., Ltd., Smiths Falls, Ont.  
R. A. Lister Co. (Canada), Ltd., Toronto  
Gilson Engine Co., Guelph, Ont.
- FEED CUTTERS**  
Gilson Engine Co., Guelph, Ont.
- GREASE CUPS**
- GRINDSTONES**  
S. Vessot & Co., Joliette, P.Q.
- GRINDERS**  
International Harvester Co., of Can., Ltd., Hamilton, Ont.  
R. A. Lister Co. (Canada), Ltd., Toronto  
S. Vessot & Co., Joliette, P.Q.  
Gilson Engine Co., Guelph, Ont.
- HARROWS**  
Cockshutt Plow Co., Brantford, Ont.  
International Harvester Co., of Can., Ltd., Hamilton, Ont.  
John Deere Mfg. Co., Welland, Ont.  
The Frost & Wood Co., Ltd., Smiths Falls, Ont.
- HAY LOADERS**  
International Harvester Co., of Can., Ltd., Hamilton, Ont.  
John Deere Mfg. Co., Welland, Ont.  
The Frost & Wood Co., Ltd., Smiths Falls, Ont.
- HARDWARE**  
Aikenhead Hardware Co., Toronto.
- HAY RAKES**  
John Deere Mfg. Co., Welland, Ont.  
The Frost & Wood Co., Ltd., Smiths Falls, Ont.
- HAY CARRIERS**
- HAY PRESSES**  
Birdsell Mfg. Co., Toronto.  
International Harvester Co., of Can., Ltd., Hamilton, Ont.
- HULLERS (Clover)**  
Birdsell Mfg. Co., Toronto.
- LIGHTNING SYSTEMS**  
R. A. Lister Co. (Canada), Ltd., Toronto  
Gilson Engine Co., Guelph, Ont.
- LIME AND FERTILIZER SOWERS**  
John Deere Mfg. Co., Welland, Ont.
- LUBRICANTS**  
Spedolene Refining & Mfg. Co., Montreal.
- MACHINE TOOLS**
- MANURE CARRIERS**
- MANURE SPREADERS**  
Cockshutt Plow Co., Brantford, Ont.  
International Harvester Co., of Can., Ltd., Hamilton, Ont.  
John Deere Mfg. Co., Welland, Ont.  
The Frost & Wood Co., Ltd., Smiths Falls, Ont.  
Gilson Engine Co., Guelph, Ont.
- MARINE FITTINGS**  
Northern Electric Co., Ltd., Montreal.
- MOWERS**  
Cockshutt Plow Co., Brantford, Ont.  
International Harvester Co., of Can., Ltd., Hamilton, Ont.  
The Frost & Wood Co., Ltd., Smiths Falls, Ont.
- MOTOR HORNS (Electric)**  
Apollo Mfg. Co., Birmingham, Eng.
- MILKING MACHINES**  
R. A. Lister Co. (Canada), Ltd., Toronto
- MILLING CUTTERS**  
Butterfield & Co., Inc., Rock Island, Q.
- OILS**
- PISTON RINGS**  
Lamontagne Ltd., Montreal, Que.
- PLOWS**  
Cockshutt Plow Co., Brantford, Ont.  
John Deere Mfg. Co., Welland, Ont.  
The Frost & Wood Co., Ltd., Smiths Falls, Ont.  
International Harvester Co., of Can., Ltd., Hamilton, Ont.
- POLICE AND FIRE ALARM EQUIPMENT**
- POWER AND LIGHT EQUIPMENT**  
R. A. Lister Co. of Canada, Ltd., Toronto.
- POWER MACHINERY**  
John Deere Mfg. Co., Welland, Ont.  
International Harvester Co., of Can., Ltd., Hamilton, Ont.  
Gilson Engine Co., Guelph, Ont.
- POWER SWITCHBOARDS**
- POTATO MACHINERY**  
John Deere Mfg. Co., Welland, Ont.  
Cockshutt Plow Co., Brantford, Ont.
- PULVERIZERS**  
Cockshutt Plow Co., Brantford, Ont.  
International Harvester Co., of Can., Ltd., Hamilton, Ont.
- PULPERS**  
Cockshutt Plow Co., Brantford, Ont.
- RAKES**  
International Harvester Co., of Can., Ltd., Hamilton, Ont.  
The Frost & Wood Co., Ltd., Smiths Falls, Ont.
- REAPERS**  
International Harvester Co., of Can., Ltd., Hamilton, Ont.  
The Frost & Wood Co., Ltd., Smiths Falls, Ont.
- REAMERS**  
Butterfield & Co., Inc., Rock Island, Q.
- ROLLERS**  
Cockshutt Plow Co., Brantford, Ont.
- ROLLER BEARINGS**
- SAW MILL OUTFITS**
- SCUFFLERS**  
Cockshutt Plow Co., Brantford, Ont.  
International Harvester Co., of Can., Ltd., Hamilton, Ont.  
John Deere Mfg. Co., Welland, Ont.
- SEEDERS**
- SCALES**
- SCREW PLATES**  
Butterfield & Co., Inc., Rock Island, Q.
- STABLE EQUIPMENT**
- SILOS**  
Gilson Mfg. Co., Guelph, Ont.
- SLEIGHS**  
Cockshutt Plow Co., Brantford, Ont.  
International Harvester Co., of Can., Ltd., Hamilton, Ont.
- SILO FILLERS**  
Gilson Mfg. Co., Guelph, Ont.  
International Harvester Co., of Can., Ltd., Hamilton, Ont.
- SOCKET WRENCHES**  
R. F. Sedgley, Inc., Philadelphia, Pa.
- SEPARATORS (CREAM)**  
R. A. Lister Co., Toronto.
- SPREADERS, MANURE**  
Cockshutt Plow Co., Brantford, Ont.  
John Deere Mfg. Co., Welland, Ont.  
International Harvester Co., of Can., Ltd., Hamilton, Ont.  
Gilson Mfg. Co., Guelph, Ont.
- SPARK PLUGS**  
Machine & Stamping Co., Toronto.  
Champion Spark Plug Co., Windsor, O.  
Apollo Plug Mfg. Co., Birmingham, Eng.  
Can. General Electric Co., Ltd., Toronto.
- SPARK PLUG CLEANERS**  
Champion Spark Plug Co., Windsor, O.
- STAMPINGS**
- TELEPHONE APPARATUS**
- TRACTORS**  
R. A. Lister Co. (Canada), Ltd., Toronto  
Gilson Mfg. Co., Guelph, Ont.  
Gray Tractor Co. of Canada, Ltd., Winnipeg, Man.  
International Harvester Co., of Can., Ltd., Hamilton, Ont.  
J. I. Case Threshing Machine Co., Inc., Racine, Wis.  
The Turner Mfg. Co., Port Washington, Wis.
- TRACTOR PLOWS**  
Cockshutt Plow Co., Brantford, Ont.  
International Harvester Co., of Can., Ltd., Hamilton, Ont.  
John Deere Mfg. Co., Welland, Ont.
- TOOLS**  
Rapid Tool & Machine Co., Lachine, Que.
- THRESHERS**  
Can. Fairbanks-Morse Co., Ltd., Montreal.  
International Harvester Co., of Can., Ltd., Hamilton, Ont.  
J. I. Case Threshing Machine Co., Inc., Racine, Wis.  
R. A. Lister Co. (Canada), Ltd., Toronto  
Gilson Mfg. Co., Guelph, Ont.
- THREAD CUTTING TAPS**  
Butterfield & Co., Inc., Rock Island, Q.
- TWIST DRILLS**  
Butterfield & Co., Inc., Rock Island, Q.
- TRUCKS**  
Eastern Canada Motor Truck Co., Ltd., Hull, P.Q.  
International Harvester Co., of Can., Ltd., Hamilton, Ont.
- WHEELBARROWS**  
Cockshutt Plow Co., Brantford, Ont.
- WAGONS**  
Cockshutt Plow Co., Brantford, Ont.  
International Harvester Co., of Can., Ltd., Hamilton, Ont.
- WATER BOWLS**
- WEEDERS**  
Cockshutt Plow Co., Brantford, Ont.
- WIRES AND CABLES**



# Butterfield

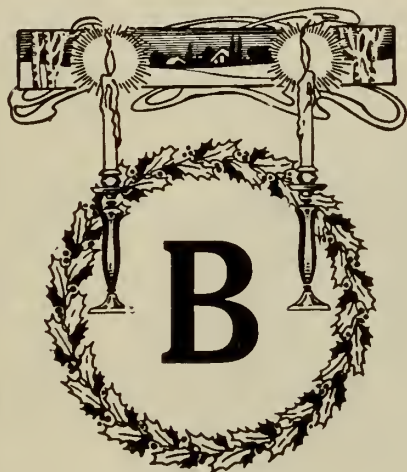

## A Very Merry Xmas

Let's have a real, genuine, old-time Merry Christmas. Let's put the panic howlers and depression pessimists to route with courage and optimism and "pep."

Believe there is no depression! Act as though there were none! And you'll find there is none.

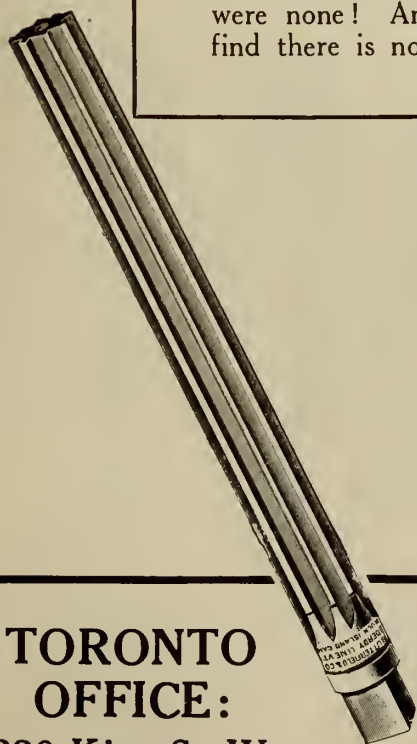

# Drills, Taps, Dies, Reamers and MILLING CUTTERS

Every month is Christmas month to the Garage and Repair Man who invariably does good work.

Wise men bearing gifts of work well paid for are only too pleased to pay tribute to him who backs up his mechanical genius with the best tools he can buy.

When selecting cutting tools, it is well to remember the high quality and honesty that have earned for Butterfield Tools the title,

*"The Tools You Buy Again"*

TORONTO  
OFFICE:  
220 King St. W.

BUTTERFIELD & COMPANY, *Division*  
UNION TWIST DRILL CO.  
Rock Island - - - Quebec



# Making a Football of the Hydro

By F. M. CHAPMAN  
EDITOR OF "FARMERS' MAGAZINE"

North East Toronto, Major Lewis, the successful candidate, had Hydro pinned on to his party name, and the Toronto dailies stood for the issue without so much as putting up the real question. As Col. Maclean says, "What about the power shortage?" should have been the unclouded issue.

The power shortage is well told of in The Financial Post, by Col. J. B. Maclean, whose sense of justice to all people nobody can impugn. He says:

"The present predicament is not due to the failure to complete the Chippawa project so much as the fact that by promise and on contract Sir Adara Beck has made himself responsible for a service which he cannot give. Manufacturers have installed equipment on the strength of his assurances and machines stand idle; citizens have built homes on promises of light and they are in darkness; householders have installed appliances sold by the Hydro and they are told they cannot use them. This situation is not due to a shortage of power. It is due to the actual fact that Hydro has sold and promised thousands of horsepower which it cannot deliver and which Sir Adam Beck must have known he could not deliver.

"We have in Premier Drury a man with brains, common-sense and courage, who refuses to be bluffed by the propagandists or awed by corporations. He at once took steps to permit the water that had been running to waste for months to be turned on and the idle machinery of the private companies to be used.

"Now comes Beck—who all along has insisted that this water should be wasted, rather than allow the private companies to use it—with a demand that it be given to him rather than supplied direct to the manufacturers who are short of power. It is hardly likely the Government will permit such an outrage on the private invest-

"If Sir William Mackenzie—and men like him—can get into his head that his attitude towards the public is about 25 years behind the times, and if the Premier will insist upon fair play to men and women who take great risks and put their money and work into electric and other industries, this province will grow tremendously—as Quebec is growing—in the next decade."

So the rural question will not down. When will we get power for our farms?

It does not look to be possible for a long time. In the meantime the Hydro men should stop their agents from making such deceptive promises to farmers on the concessions. They misrepresent two things—the cost of Hydro when they do get it, and secondly the time when it will come.

It stands to reason that farmers in our thinly settled townships will not pay the price to get the current. A single service station to serve a district of fifteen miles square will cost \$15,000. Then you have the pole lines and wiring. This will produce an overhead charge annually that will be almost impossible unless all farmers use the line. For that reason, we have advised farmers to instal their own electric plants, if they can get it reasonably done, and can use gasoline power from a tractor or stationary engine for their heavy power needs. The overhead will compare favorably with the Hydro if the sellers of these outfits do not charge more than they should. Moreover no tree across a long distance line will put their farms in darkness. From any standpoint many farmers prefer to own their own plant in their own cellar. Farmers two miles away from a projected Hydro line are foolish to sit in darkness until the light from Niagara shines.

## New Lauson Catalogue

A MOST attractive catalogue has just been issued by the John Lauson Mfg. Co., New Holstein, Wis. It contains general information regarding the application of power to the farm and the different operations which the tractor is suited to perform. The last part of the catalog is devoted to the mechanical features of the Lauson 15-30 tractor.

The booklet is 8½ x 11 in. size, and has about 18 pages of attractively illustrated reading matter, which is easily read.

CAN farmers hope to get Hydro power to their farms within a reasonable time?

This is a pertinent question. It must be answered soon for the farmers are getting tired of waiting for better lighted homes and farm conveniences.

The Hydro cannot blame anyone else for the delay or for misrepresentation. They have the whole authority to go ahead. Definite frank statements should be made that tell the actual situation regarding farm-power possibilities.

Hundreds of farmers have had their houses wired for months waiting for the juice. Are they going to get it? What price will they have to pay for it?

Hydro power is the correct thing for us if it can function. If Hydro comes by the farm then one should have the Hydro installed and so help out the whole scheme. Our Hydro power and light will pay any farmer to instal, because it is what we are all wanting on the farms. Once used electricity will stay.

But what about the 180,000 farmers in Ontario who, as yet, have not the power?

On behalf of these farmers we rise up and ask this, a pertinent question. What is the future outlook for power on these farms?

Surely this is a real question. Can we not answer it without being placarded by certain party politicians as unfriendly to the Hydro and a servant of the big interests?

Disloyal indeed! Party politicians are trailing the word Hydro in the dust. They wear it in their lapels and on their windshields. They hide themselves in the folds of its banners as many a convincing politician has used the old Union Jack.

Hydro is essentially a fine idea. To deliver power to the people at cost is something for which all sensible ratepayers are asking. Drury believes the people should be furnished power from our wonderful water resources at cost. He has aided Hydro development in so many ways since he came into power. He is pledged to support it by seeing that it is carried out efficiently.

Drury is a better friend to the whole system of public ownership than are many of the satellites of the system itself, who are in it for the living they get from it.

Drury has saved the system from being overloaded with unprofitable ventures and time will reveal that he has been right.

But what about power for the farmers? Party politicians are saying that the next sitting of the legislature is going to put Hydro clearly up to the Government. In other words, they can truthfully say these politicians are going to make Hydro a political football for their own little off-side game. Drury's stand will be unassailable, we trust, if he follows the line of his declared policy.

One thing that will come out will be the better answer to our question, when are the farmers to get this power?

Time and time again Farmers' Magazine, without any thought of politics, has urged upon farmers the folly of waiting for Hydro except where they are in direct touch with a projected Hydro line that is already moving in the construction of a line. And that position Farmers' Magazine reiterates for it does not look for a plentitude of power in this Province for some time, so that farmers will be able to hitch up to the lines to satisfy their needs.

Industrial demands are heavy. Manufacturers are also short of power. And power to big centres costs less to deliver and the revenue is greater. Therefore it is but natural to suppose that the Commission will sell their power to these users first in order to make a good showing. On just such lines do the local politicians in the big consuming cities feed their electors about municipal voting day. In the recent contest in



The competition between the horse and the tractor is purely economic—both will continue to have special advantages for some years to come. The illustration shows a tractor performing a work which the horse could not do. The tractor is rapidly becoming indispensable on the modern farm.

"The power shortage becomes more and more acute. Manufacturers throughout the Hydro-Electric belt are suffering losses entailing millions. Thousands of workers are left idle without notice, either to lose wages or collect their pay without earning it. The situation is becoming almost unbearable.

"The Hydro have not only fallen down themselves, but in their efforts to injure private ownership they forced the private companies to close down machinery, discharge workers, and let water run to waste over Niagara Falls.

"Notwithstanding all these handicaps, the private companies are able to keep their customers fully supplied. In Quebec, under private ownership, competent management has planned ahead and has ample power at much lower cost than Ontario.



THE FORD LEADS THE WAY

Fine! But it isn't every vehicle that can make as short a turn as a Henry!  
—Spencer in Omaha "World-Herald."



# "In the Smugglers' Den"

*An Intimate and Dramatic Story of Boot-Leggers and the Activities of Rev. J. O. L. Spracklin of the Border Cities.*

**M**R. CHARLES CHRISTOPHER JENKINS, the writer of this story, arrived in Windsor a few hours before Trumble was shot by the Rev. J. O. L. Spracklin; and during the next few days among the experiences which befell MacLean's Magazine special representative was one of particularly dramatic and timely interest—a few hours spent within the lair of one of the smugglers' "Master Minds." This graphic story from Mr. Jenkins' pen will enable you to get a real grip of what this all means, particularly from the side of those who are beyond the pale of the law.

*The Story is illustrated by some exclusive and timely photographs showing the chief actors and various resorts within the sphere of their activities.*

## December 1st Issue of MACLEAN'S Brimful of Fascinating Reading

### "AUTOBIOGRAPHY OF MRS. ASQUITH"

Wife of the former Prime Minister of Great Britain. One of the strongest and most interesting stories Mrs. Asquith tells in her extraordinary reminiscences.

### "THE CITY OF PERIL"

By Arthur Stringer. Four more pages of this gripping, enthralling, melodramatic story of Bolshevistic adventure in New York.

### "JEFF HEARS THE CALL"

By C. W. Stephens. The story of a fight with forest fire, of rescue by the air route from a horrible death by flames.

### "LINKING TWO INLAND SEAS"

By J. L. Rutledge. Here you have the account of the struggles which led to the construction of one of Canada's greatest transportation links.

### "THE TEST"

By Harry C. Douglas. This is a charming little short story with a surprising conclusion.

### "THE DRAMA OF OUR GREAT FORESTS"

By Arthur Heming. The second instalment of this gripping serial is entitled "Oo-Koo-Hoo's Eldorado." On the cover will be another Heming picture.

### "FLIRTING WITH OUIJA"

By Col. George H. Ham. The genial George's adventures in the mystic, with necromancers and hypnotists.

### "LEAVES OF KACHUBOONG"

By Madge Macbeth. An intriguing detective story by the well-known Canadian authoress, who has specialized in depicting criminal types.

### "FIRST ROW, ORCHESTRA"

By Leslie G. Barnard. In this you have the catchy story of a small town girl who became a big town actress.

### "OUR GOLDEN FLOOD ROARS EAST"

By Nicholas North. The story of how our grain is graded; the difficulties in marketing 275,000,000 bushels of wheat.

## Review of Reviews

*Some of the subjects treated in our reviews in December 1st issue include:*

Fiume Under d'Annunzio.  
The War Spirit in the World—Sisley Huddleston.  
Russia in the Shadow—H. G. Wells.  
Benedict XV, Royal Diplomat.  
The Irresistible Thing—Sir Gilbert Parker.

The Russian Intelligence—Leo Pasvolksy.  
Simple Solution of the Labor Problem.  
Letting the Prisoners Govern Themselves—Frank Tannenbaum  
German Universities Hard Up—Allen W. Porterfield.  
The New Search for Oldest Man—Roy C. Andrews.

*Secure Your Copy Early—The Supply is Limited*

*Over 80,000 Canadian Families Buy*

# MACLEAN'S

"CANADA'S NATIONAL MAGAZINE"  
**DECEMBER 1st ISSUE** On All News-stands **20c**

**A TRIAL—6 MONTHS FOR \$1.50**

MACLEAN'S sells for \$3.00 a year—should be more. We want you to get acquainted with MACLEAN'S, for we know that after we once introduce you to "Canada's National Magazine" you two are going to be friends for life. So, to make you known to each other, we will accept your subscription now for only six months to start off with. In other words, we want you to "try out" MACLEAN'S and see for yourself just how good it is! Don't miss this unusual opportunity. Simply sign the coupon, pin a postal note to it, and mail it to us

**TO-DAY**

Tear off here and mail.

The MacLean Publishing Company,  
Dept. M.T.I., 143 University Ave., Toronto, Ontario.

I accept your offer. I am enclosing \$1.50 to pay for MACLEAN'S MAGAZINE for six full months. Please start me off with the January issue.

Name .....

Address .....



# Apollo

## BRASS SPARK PLUGS

—Are Sure and Satisfactory Sellers

You're on a good thing when you handle APOLLO PLUGS—they represent the highest standard of British plug manufacture, are fully tested to ensure maximum efficiency and are guaranteed to give complete satisfaction.

With the APOLLO range of plugs you can promptly meet every plug request—there are models for every type of Car, Motor Truck and Tractor engine—and every plug carries a GOOD PROFIT for YOU.

Super Mica Plug is specially designed for high-speed, high-compression engines. It is unaffected by excessive heat and of exceptional durability—a plug that gives a quick start and adds power to the Engine. Retail price ..... **\$1.25**

Porcelain Plug is specially designed for the FORD engine. It has Solid Brass body, 1/2-in. gas thread, is clean to handle, will not rust, fits the special FORD spanner, is insulated with finest porcelain and is detachable for ..... **90c**

Get on to the APOLLO PLUG proposition and you'll do big business in selling plugs. We can give prompt shipment of all models and supply you with posters, showcards and advertising literature. Write us for trade terms and full particulars of our models.

### APOLLO PLUG MFG. CO.

Canadian Head Office:

135 King St. West, Toronto. Factory: Birmingham, Eng.

Plugs for all engines



APOLLO No. 1 Super Mica Plug

APOLLO Special



Overtime Tractor Plug



APOLLO L.C.B. Special FORD Plug