

THE CANADA LUMBERMAN



TWENTY-FIFTH ANNIVERSARY NUMBER

THE C.H. MORTIMER PUBLISHING CO. TORONTO LIMITED.

TORONTO - MONTREAL - WINNIPEG



FACTORY AND WAREHOUSE OF WOODS LIMITED, OTTAWA.

"Pardon Me!! Can you inform me where I can purchase the right kind of supplies for my vans in our lumber camps, and all in one place; it is such a waste of time to be obliged to run all over the country for these little lines?"

"Certainly. With pleasure. WOODS, LIMITED, Ottawa, we find to be able to supply all our needs promptly, and intelligently, as they have made a study of this business, and being manufacturers, they save for us the wholesaler's profit, and as their stock includes all lines needed, we simply use them in all cases, and their goods are durable, roomy, and well sewn together, and include Blankets (made in their own mill in Renfrew), Tweed, Etoffe, Kersey (manufactured in their mill in Wakefield), Tents of their special Non-Absorbent Duck, which we find last three times as long as any other make and are wind and rain proof, while their workmanship is of the best and deliveries immediate, as their capacity for manufacturing is greater than any other; Overalls, Top Shirts, Pants, Underwear from the coarsest to the finest, including their special unshrinkable Ribb, 224 at \$7.25, 20-oz.; 204 at \$9.00; 2004 at \$11.00. Woods' Oil-Tan Larriqans, all kinds, Beef and Moose Moccasins, Hand-knit Mitts, Fowler's "Ottawa" Axes, Pipes, Towels, Sweaters, Cardigan Jackets, and all kinds of Leather Mitts, Smallwares, Bags, Tarpaulins, Horse Covers, Etc. Snow Shoes, Tweed-Duck Leather and Sheep-Skin Lined Coats, Mackinaw Goods."

Woods Limited, Ottawa, Can.

THE PROVINCE OF QUEBEC

REACHED BY RAIL AND WATER ROUTES ON THE EAST, WEST AND SOUTH

Possessing immense areas of Spruce, countless water powers and cheap labor, Quebec's destiny is to be

"THE WORLD'S" WOOD PULP SUPPLIER

The largest Asbestos Producing Country in the world. Immense deposits of fine Iron Ores (Limenite), Hematite and Magnetite) abound from Labrador to Lake Temiscamingue, waiting development.

PEAT DEPOSITS

of large area exist in various localities.

High grade agricultural homestead land available at nominal prices, north and south of the St. Lawrence River, from Gaspé Basin to the Ontario boundary.

HUNTING, SHOOTING AND FISHING

Unexcelled in any part of the world. Moose abound from the Gaspé peninsula to the extreme west. The famous "caribou barrens" of the Laurentides National Park vie with Newfoundland as to numbers and accessibility. Red deer are abundant, except in the Northern districts. All species of waterfowl (migratory) from East to West in season. Deep sea fishing, halibut, cod, mackerel, herring, etc. The inland waters teem with trout and bass, whilst our salmon rivers have a world-wide reputation. The ruffed grouse (partridge), our veritable "national bird," is to be found in quantity, except in the settled districts. Quebec is furthermore a prominent producer of fur-bearing animals, a large trade in this line being done.

For Any Information on Any Point Write the

DEPARTMENT OF LANDS, MINES AND FISHERIES

Quebec, P. Q., Canada

Allis-Chalmers-Bullock, Limited, Montreal

SAW MILL MACHINERY

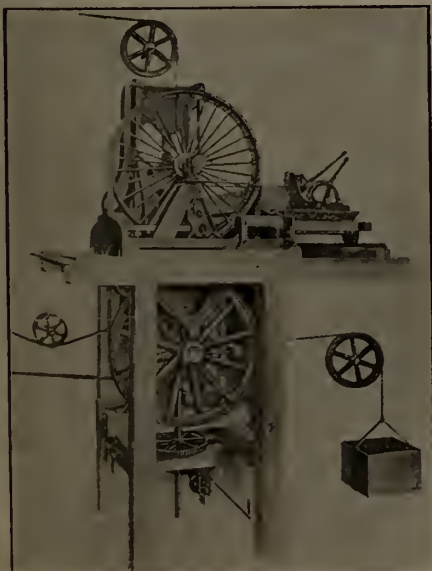

NEW ALLIS DOUBLE CUTTING TELESCOPIC BAND MILL

So as to bring the point where the saw leaves the upper wheel as close as possible to the top of the different sized logs, resulting in a great increase of efficiency.

Band and Circular Saw Mills,
Carriages, Set Works and Appurtenances,
Conveying and Transferring Machinery,
Trimmers, Slashers and Cutting Off Saws,
Edgers, Lath Mills and Bolters,
Adjustable Arbor Boxes, Filing Room Tools,
✻ ✻ ✻ Timber Preserving Plants

Also Makers in Canada of . . . **Bullock Electrical** Motors and Generators

Head Office and Works: MONTREAL

Branches: HALIFAX, N. S. TORONTO, ONT. WINNIPEG, MAN. ROSSLAND and VANCOUVER, B. C.

THIS MEANS YOU!

When you arrive in Toronto do not fail to walk through my new show rooms. You cannot miss them, the Round Building right next to Union Station. You have an invitation to walk from Station Street through to Front Street, and at the same time inspect the most magnificent display of Machinery in America. Below you will find a partial list I have for immediate delivery.

H. W. PETRIE.

AUTOMATIC ENGINES.

- 16 x 36 Corliss
- 11 x 24 "
- 10 1/2 x 24 Brown
- 10 x 10 Peerless
- 10 x 15 Jewel
- 10 x 12 "
- 10 x 12 "
- 8 x 10 "
- Throttling Governor Engines
- Horizontal, Whitehill Smith
- 20 1/2 x 36 Right Hand and Hampson
- 20 x 30 Right Hand, McIntosh Hemphill
- 20 x 24 Right Hand, Jackson
- 12 1/2 x 18 Waterous
- 12 x 12 Centre Crank Laurie
- 11 x 13 Right Hand
- 11 x 12 Centre Crank Laurie
- 10 1/2 x 24
- 8 x 16
- 10 x 15
- 10 x 10 Centre Crank Waterous

UPRIGHT ENGINES.

- 7 1/2 x 9 Centre Crank
- 7 1/2 x 8 Dutton
- 7 1/2 x 18

VERTICAL MARINE ENGINES.

- 6 x 12 x 9 Fore and Aft Condensers and Pumps
- 6 x 12 x 9 " " " " " "
- 7 x 14 x 10 " " " " " "
- 7 x 14 x 10 " " " " " "
- 8 x 16 x 12 " " " " " "
- 10 1/2 x 12 Buffalo
- 9 x 12 Clark Bros.
- 7 1/2 x 9 Dutton
- 7 1/2 x 8 " "
- 6 x 7 1/2 " "
- 5 x 7 1/2 " "
- 5 1/2 x 5 " "
- 3 1/2 x 6 " "

COMBINED PORTABLE ENGINES AND BOILERS ON WHEELS.

- 16 H. P. Waterous
- 14 " " "
- 14 " " "

TRACTION ENGINES.

- 17 H. P. Compound Bell
- 14 " " Waterous
- 10 " " Westinghouse

HORIZONTAL TUBULAR BOILERS.

- 72 x 14' for 100 lbs. steam
- 60 x 14' 84 3" tubes
- 60 x 16' 79 3 " "
- 60 x 17' 6" 54 4 " "
- 57 x 13' 9" 84 3 " "
- 56 x 14' 64 3 " "
- 56 x 14' 60 3 " "
- 48 x 15' 6" 52 3 " "
- 48 x 13' 6" 52 3 " "
- 44 x 14' 6" 51 3 " "
- 44 x 12' 52 3 " "
- 44 x 13' 6" 43 3 " "
- 44 x 13' 39 4 " "
- 44 x 14' 6" 40 3 " "

VERTICAL BOILERS.

I have in stock at all times a full complement of Upright Boilers from 1 to 50 H. P. inclusive.

PUMPS.

- 12 x 7 x 12 Northey
- 6 x 4 x 7 Duplex
- 5 1/2 x 3 1/2 x 7 " "
- 4 1/2 x 2 1/2 x 4 " "
- 3 x 2 x 3 Duplex
- 7 x 4 x 6 Gilbert

WOODWORKING MACHINERY.

- 27" Obl. Surfacr Red Bed, Cowan
- 26" " " " McGregor Gourley
- 24" Surface Planer, Clark & Demill
- 24" Obl. Surfacr, McGregor Gourley
- 24" No. 1 Planer
- 24" Surface Planer, Harper
- 24" " " Dundas
- 24" Pony Planer, Clark & Demill
- 16" " " " "
- 24" Surfacr " " "
- 12" Pony Planer " " "
- 24" Planer, Matcher and Moulder, Clark & Demill
- 24" Monitor Planer " " "
- 24" Obl. Surfacr and Matcher, Dundas
- 18" Little Giant Planer, Matcher and Moulder
- 18" Little Giant Planer and Matcher
- 30" Buzz Planer or Matcher, Oliver make
- 16" Buzz Planer, Clark & Demill
- 55" Stroke Jointer " " "

And other machines too numerous to mention for want of space.

I will be much pleased to mail my latest stock list to any address on request. I also carry a large and extensive line of Iron Working Tools and Supplies in stock and on which I am prepared to make some very close prices. Soliciting your patronage in the future, as in the past, and wishing you all a Prosperous New Year.

H. W. PETRIE, TORONTO.

CANADIAN OFFICE & SCHOOL FURNITURE CO. LIMITED
 PRESTON ONT.
 FINE BANK OFFICE, COURT HOUSE & DRUG STORE FITTINGS.
 OFFICE, SCHOOL, CHURCH & LODGE FURNITURE
SEND FOR CATALOGUE



Sole Canadian Agents - Prices Reduced
WATEROUS, BRANTFORD, CANADA

SCRIBNER'S LUMBER AND LOG BOOK

A handy book for Lumbermen, Gives Correct Measurements of Scantlings, Boards and Planks; Cubical Contents of Square and Round Timber; Doyle's Rules, and much other practical information.

Price 35 Cents

Address:
The Canada Lumberman
 TORONTO, ONT.

ESTABLISHED 1849.
BRADSTREET'S
 Capital and Surplus, \$1,500,000.
See Throughout the Civilized World.

Executive Offices:
 Nos. 346 and 348 Broadway, NEW YORK CITY, U.S.A.

THE BRADSTREET COMPANY gathers information that reflects the financial condition and the controlling circumstances of every seeker of mercantile credit. Its business may be defined as of the merchants, by the merchants, for the merchants. In procuring, verifying and promulgating information, no effort is spared, and no reasonable expense considered too great, that the results may justify its claim as an authority on all matters affecting commercial affairs and mercantile credit. Its offices and connections have been steadily extended, and it furnishes information concerning mercantile persons throughout the civilized world. Subscriptions are based on the service furnished, and are available only by reputable wholesale, jobbing and manufacturing concerns, and by responsible and worthy financial, judiciary and business corporations. Specific terms may be obtained by addressing the company or any of its offices. Correspondence invited.

THE BRADSTREET COMPANY.

OFFICES IN CANADA: Halifax N.S. Hamilton, Ont. London Ont.; Montreal, Que.; Ottawa, Ont.; Quebec, Que.; St. John, N. B. Toronto, Ont. Vancouver, B.C.; Winnipeg, Man.

THOS. C. IRVING,
 Gen. Man. Western Canada, Toronto

The . . .
QUEEN CITY OIL CO.
 LIMITED

Head Office: TORONTO.

HIGHEST GRADES OF
Refined Oils
Lubrication Oils

AND ALL

Petroleum Products

Perfect Swing Shingle Mill

Fitted with our "Automatic Trip."

Best Swing Shingle Machine on the Market today for cutting Shingles, Headings, Etc. . .

It will pay you

to write for description and price before placing your order.

We also Manufacture a complete line of . . .

SAW MILL MACHINERY, ENGINES AND BOILERS

THE
Owen Sound Iron Works Co.
 LIMITED
 Owen Sound, Ont.

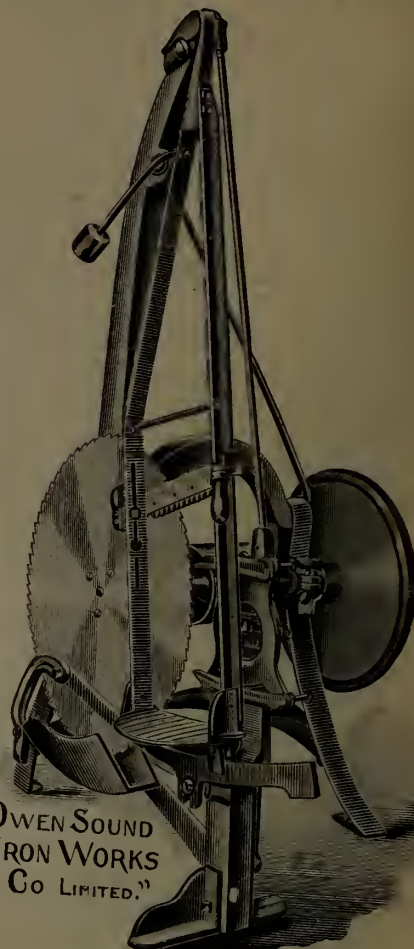

"OWEN SOUND IRON WORKS CO LIMITED."

SEND FOR CATALOGUE

THE HOE CHISEL TOOTH SAW MAKES MONEY FOR THE MILLMAN

IMITATED BUT NEVER EQUALED.

THE GENUINE MADE ONLY BY
R. HOE & CO.
 504 to 520 GRAND ST.
 NEW YORK



40,000 IN USE.

THE CANADA LUMBERMAN

and WOOD-WORKER

VOLUME XXV.
NUMBER 1.

TORONTO, MONTREAL AND WINNIPEG, CANADA, JANUARY, 1905

TERMS, \$1.00 PER YEAR
Single Copies, 10 Cents.

R. SPENCE & CO.

Beech File Works.
HAMILTON, ONT.
FILE AND RASP MANUFACTURERS
AND RE-CUTTERS
And trial order solicited. Write for price list
and terms.
C. P. MOORE, PROPRIETOR.

RAILS YARD LOCOMOTIVES

For Logging Tramways, Switches,
Etc.
New and Second-Hand.
John J. Gartshore
83 Front St. West,
(Opposite Queen's Hotel,) Toronto.

WIRE ROPE



All Kinds and Sizes
and for
All Purposes.

Standard and Lang's
Patent Lay.

Prices Right.
Prompt Shipments.

THE B. GREENING WIRE COMPANY, LIMITED
MILTON, ONT. MONTREAL, QUE

The Ottawa Saw Co.
LIMITED
Middle Street, OTTAWA, ONT.
Sandvik Swedish Steel
Band, Gang and Circular Saws
P. M. FEENY, Manager.

Leather Belting

It isn't the price, it's what
you get for the price, that
counts.

J. L. GOODHUE & CO.,
DANVILLE, QUEBEC.

WOODS LIMITED

Wholesale Manufacturer of

LUMBERMEN'S SUPPLIES

Tents and Tarpaulins made of our special non-
absorbent duck. Overalls, Top Shirts, Driving
Pants, Shoes and Hats, Underwear, Blankets,
Axes, Moccasins, etc.

64-66 QUEEN ST. - - OTTAWA, ONT.

DICK'S BELTINGS



Never is
affected by
wetness, and
does not
stretch

Excels in
Transmission
Power

Always
Uniform.

LARGE STOCK
ON HAND

WRITE TO SOLE AGENTS:

J. S. YOUNG, 413 St. Paul Street
MONTREAL

D. K. McLaren

GENUINE

Oak Belting

MILL SUPPLIES

751 Craig St., Montreal.

132 Bay St., Toronto.



NO Wasted Energy : Every Bit Pushes

'ATLAS' CAR MOVERS

WILL MOVE
ANY CAR

W. H. C. MUSSEN & CO.
MONTREAL, QUE.

THE E. R. BURNS SAW CO.

TORONTO, ONT.

MANUFACTURERS OF HIGH-GRADE

Circular and Long Saws

UNEXCELLED

SHINGLE SAWS



The Wm. Hamilton Mfg. Co., Limited

Builders of a Complete Line of

SAW MILL MACHINERY

The

STEAM TENSION

BAND MILL* FOR SINGLE OR
DOUBLE CUTTING



Before the introduction of the Steam Tension Mill, it had been the universal custom to maintain the strain on the saw by the use of some system of levers and weights.

It is well-known that the action of a weight--especially one as heavy as must be used in the tension mechanism of a band mill--is necessarily slow on account of its inertia.

Every practical mill man will admit that, in order to get the best results in sawing, the tension device should be very sensitive and capable of responding instantly to the varying demands of the work. As it is manifestly impossible for any form of weight tension to meet these requirements, we have

substituted for the weight a direct acting steam cylinder, so arranged that the strain on the saw can be varied at will from 3,500 pounds up to any required amount.

It will be evident to anyone familiar with the use of steam that the action of this saw straining device must be instantaneous, and consequently the saw will always be kept in proper tension to do its best work.

We have a booklet giving a great many more points of advantage possessed by this mill—write Dept. L for it.

Branch Office :
Vancouver, B. C.

Head Office and Works :
Peterborough, Ont.

MOREAU'S PULPWOOD BARKING MACHINE

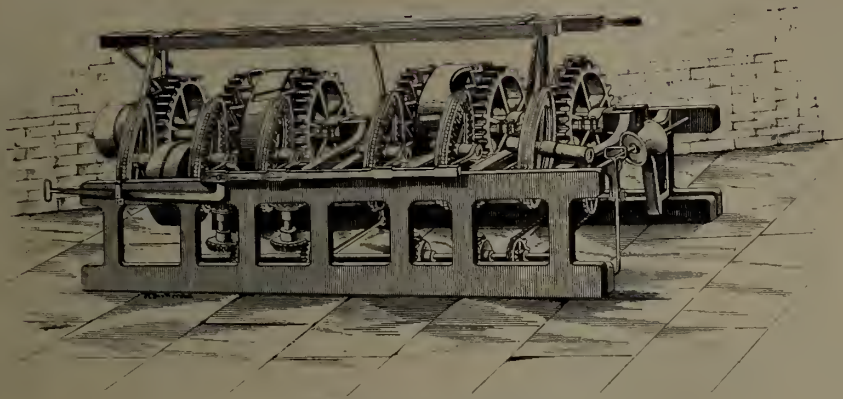

Weight 4,200 lbs.

Latest and best Pulpwood Barking Machine. Requires about 7 h.p. to drive it full speed in work and one man can handle it and bark 22 to 30 cords of 4 foot wood per day according to average size of wood.

Wood is fed end on and any size from 3 to 24 inches, as the wood runs without loss of time between sticks. No long shavings and greatest economy in wood. Machines may be seen working any time. Write me for full particulars.

TESTIMONIAL

We, the undersigned, were invited by Mr. Smyth, Selling Agent of the MOREAU BARKING MACHINE, to visit Moosepark to see one of these machines in operation. We accepted on the 27th October, and ourselves measured $3\frac{3}{8}$ cords of wood in the rough (100 sq. ft. S. M.) of 4 feet wood, which was put over the machine in 58 minutes and measured up afterwards $2\frac{1}{2}$ cords (80 sq. ft. S. M.)

The wood was small and of very poor quality, which was in our opinion a very severe test for the machine, and we are perfectly satisfied that with fair size and quality wood the machine would work faster and with considerably less loss. The barking was in every way satisfactory and two men handled the machine, but with a feed chain the machine can be run by one man satisfactorily. We consider it an all round good machine, well built, easily manipulated and not complicated in its parts, and heartily recommend it to any person requiring a good barking machine.

O. W. ORDWAY, Lumber and Pulpwood,
Ste. Anne de Beaupre, P.Q.

W. H. MITCHELL, Lotbiniere Lumber Co.,
Lyster, P.Q.

R. S. P. SMYTH - QUEBEC, QUE.

Sole Agent for Canada

*P. O. Box 236
L. D. Phone 386*

Nanaimo Saw Mill and Sash and Door Factory

Office: Mill Street

A Complete Stock of Rough and Dressed Lumber Always on Hand, Shingles, Laths, Pickets, Doors, Windows and Blinds, Mouldings, Scroll Sawing, Turning, and all kinds of Wood Finishing Furnished ❀ ❀ ❀ ❀ ❀ ❀ ❀ ❀ ❀ ❀ ❀ ❀

A. HASLAM, PROPRIETOR
P. O. DRAWER 36

— **NANAIMO, British Columbia**

THE E. LONG MANUFACTURING CO., ORILLIA, ONT.

THESE SAW CARRIAGES ARE MADE OF CAST STEEL, AND OPEN 36 TO 54 IN. FROM SAW.

We build Double Edgers, Steam Feeds, Log Jacks, Live Rolls, Trimmers, Slab Slashers, Steam Niggers.

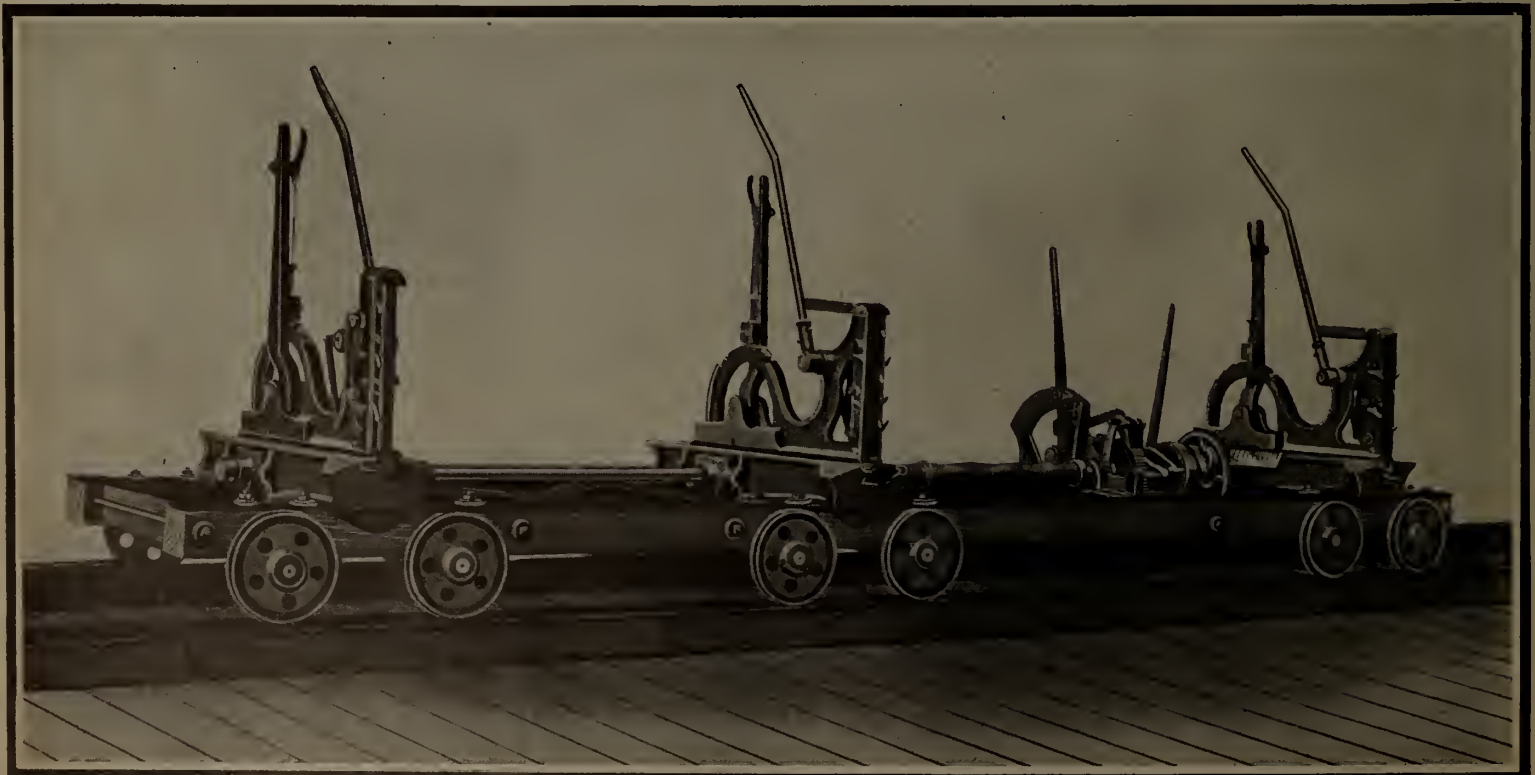

COMPLETE LINE OF SAW AND SHINGLE MILL MACHINERY
WRITE FOR CATALOGUE AND PRICES

DODGE

POWER TRANSMISSION SPECIALTIES

DODGE

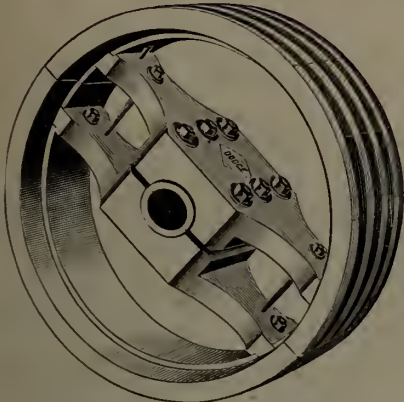

Standard Wood Split Pulley.



Adjustable Floor Stand.



Adjustable Pillow Block.



Iron Grooved Wheels.



4 Arm Dodge Wood Pulley.

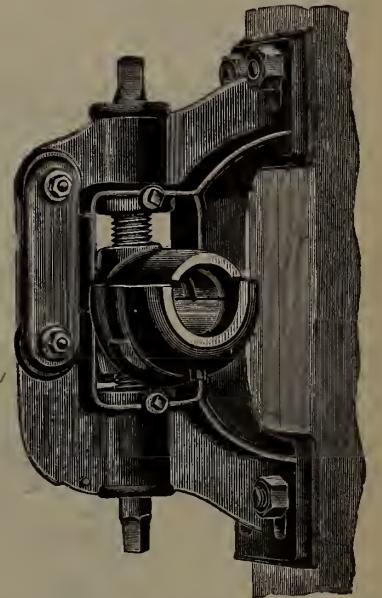

Ball and Socket Post Hanger.



Flange Coupling.



Friction Coupling.



Adjustable Belt Tightener.



Self-Oiling Pillow Block.

Send for Descriptive Catalogue and Prices on Anything You Require.
Full Line of Supplies Always in Stock. ♡ ♡ ♡ ♡ ♡ ♡ ♡ ♡

DODGE MANUFACTURING CO.

TORONTO MONTREAL

THE

MAPLE LEAF SAW WORKS

Shurly & Dietrich
GALT, ONT.

Manufacturers of

- CIRCULAR SAWS
- GANG SAWS
- MILL SAWS
- BAND SAWS
- CROSS-CUT SAWS

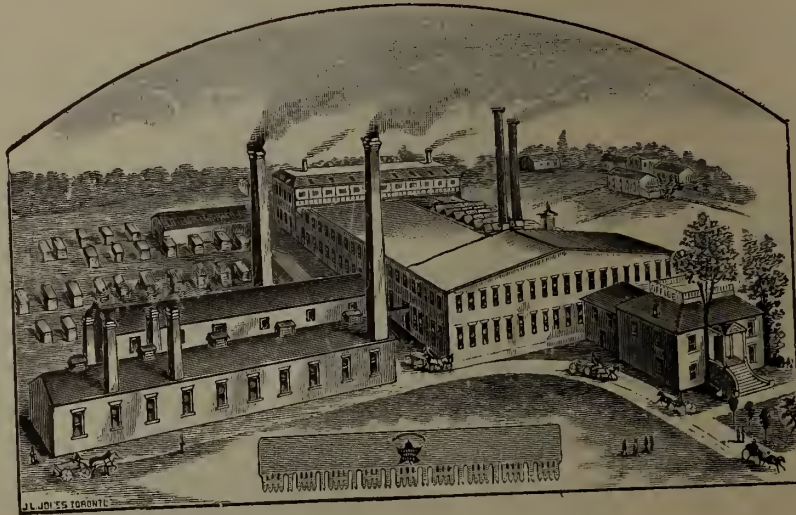

Manufacturers of

- HAND SAWS
- BUCK SAWS
- PLASTERING TROWELS
- BUTCHER SAWS
- STRAW KNIVES, &c.

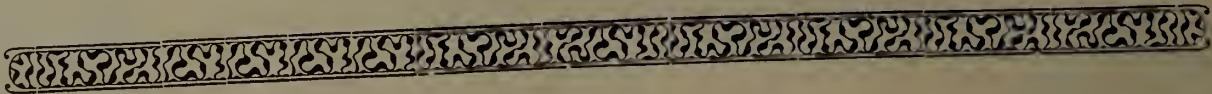

Maple Leaf Saw Set

MANUFACTURED BY

SHURLY & DIETRICH, Galt, Ont.

Directions.—Place the set on the point of tooth, as shown in the accompanying cut, and strike a very light blow with a tack hammer. If you require more set, file the tooth with more bevel. If you follow directions you cannot make a mistake. Be sure and not strike too hard a blow, and it will set the hardest saw. On receipt of 40 cents we will send one by mail.

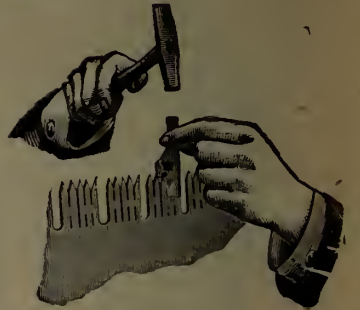

We are the only manufacturers in the world who export Saws in large quantities to the United States.

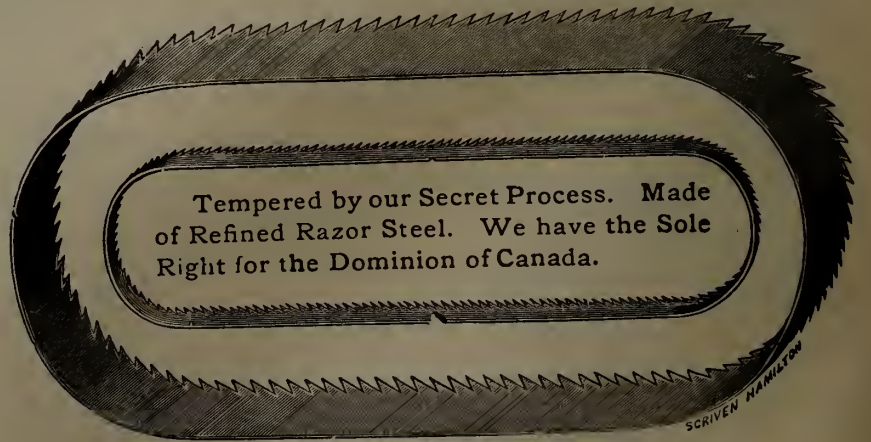

We Manufacture

HIGH GRADE BAND SAWS

Of All Widths and Lengths.

These Saws are made of Refined Swedish Steel imported direct, and tempered by our Secret Process; for Fine Finish and Temper are not excelled.

This Saw Stands Without a Rival

AND IS THE

FASTEST CUTTING SAW IN THE WORLD!

Its Superiority consists in its Excellent Temper. It is made of "Razor Steel," which is the finest ever used in the manufacture of Saws. We have the sole control of this steel. It is tempered by our secret process, which process gives a keener cutting edge and a toughness to the steel which no other process can approach.

- GROUND THIN ON BACK
- Save Labor
- Save Time
- Save Gumming
- Save Files

Modern High-Grade Wood-Working Machinery

For Manufacturing
**HUBS, SPOKES, WHEELS, WAGONS,
CARRIAGES, RIMS, SHAFTS, POLES,
NECK-YOKES, SINGLE TREES, BARREL
HOOPS.**

Handles of Every Kind, insulated Pins, Spools,
Bobbins, Oval Wood Dishes, and General Wood-
Work.

Invented and Built by

THE DEFIANCE MACHINE WORKS,
Defiance, Ohio, U. S. A.

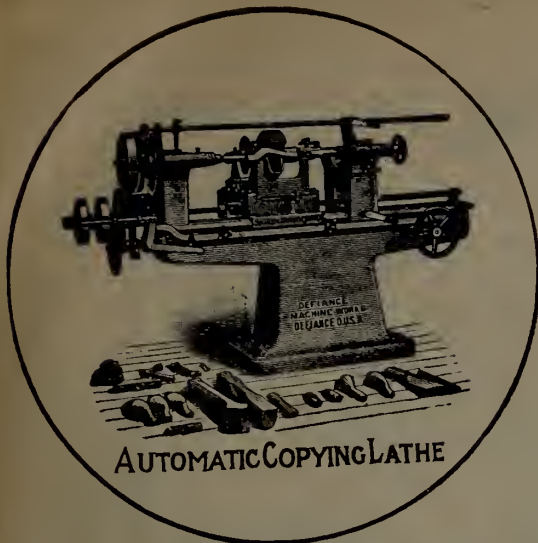

AUTOMATIC COPYING LATHE



SINGLE ARM WOOD BENDER

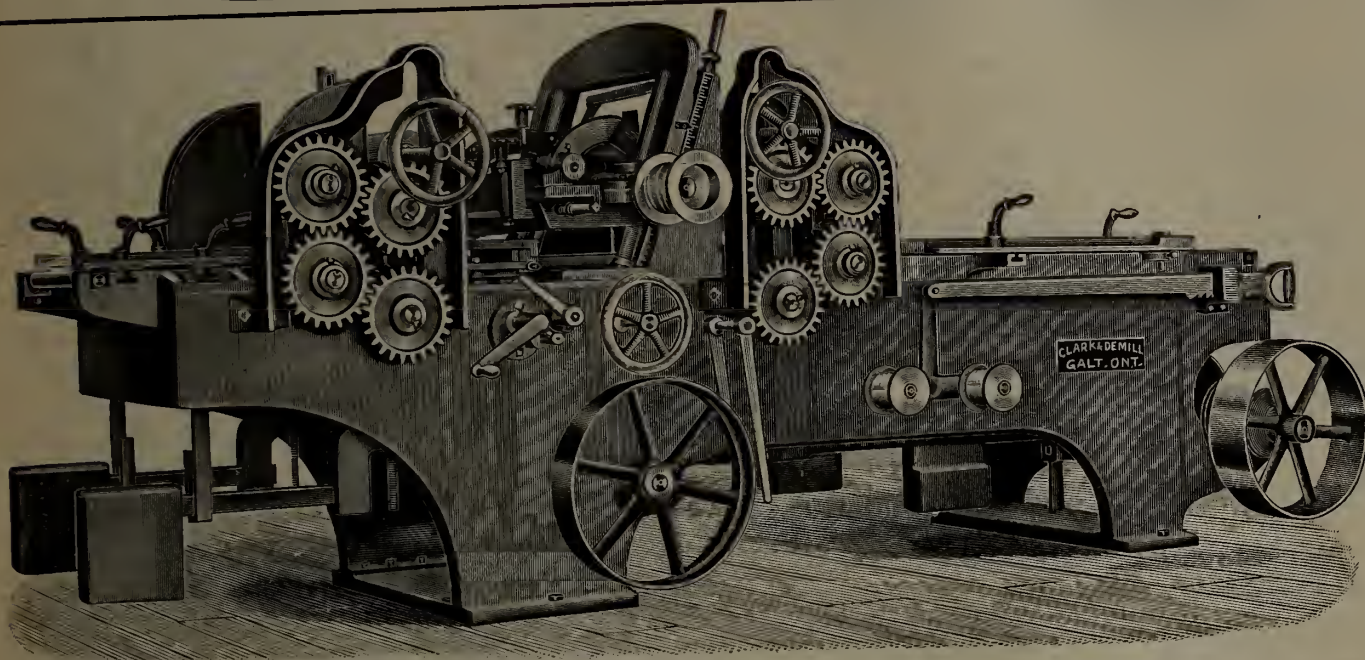

Our No. 72 LIGHTNING PLANER AND MATCHER

Kindly note that we make
this machine in different
sizes, single or double
cylinder, as desired.
Parties desiring thor-
oughly up-to-date ma-
chinery, will find it to
their advantage to write
us before placing their
order.

Write for new Catalogue.

Clark & Demill
Galt, Ont.

Our Celebrated **Rotary Cutting Veneer Machines**

made in over sixty sizes, have stood the test and proved equal to any proposition to reduce logs into thin lumber and veneers.

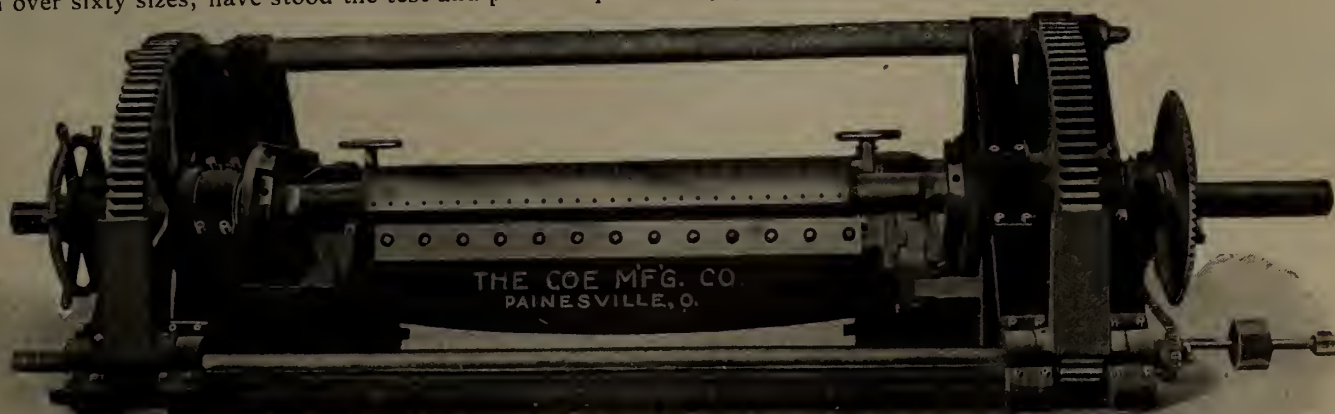

THE COE MFG. CO.
PAINESVILLE, O.

ECLIPSE CO.
PAINESVILLE, O.

The product is high grade.
The output is great.
The cost of operating and maintenance is reduced to a minimum.
Quite a combination, is it not ?

Timber and mill owners should get in early.
Buy a Coe Veneer Cutting and Drying outfit and prepare to
supply thin lumber and veneers which have a healthy growing
demand. More money in it than sawing your logs into lumber.

WRITE US.

THE COE MANUFACTURING COMPANY, Painesville, Ohio, U. S. A.

Established 1852.

Largest Builders of Veneer Cutting Machinery in the world.

THE STUART MACHINERY CO., LTD.

ESTABLISHED 1878

INCORPORATED 1900

764 & 766 MAIN ST., WINNIPEG, MAN.

SPAMBRO SE,
MECHANICAL ENGINEER

J. L. POLLOCK,
CHIEF SALESMAN

R. H. MAINER,
ACCOUNTANT

W. A. MCLEOD,
MANAGING DIRECTOR

ROY STUART,
CHIEF ELECTRICAL DEPT.

MISS L. VANCAMP,
STENOGRAPHER

W. E. SUTHERLAND,
BOOKKEEPER

JAS. MOLLAND,
FOREMAN ELECTRICIAN

ROBT MCKENNA,
FOREMAN MACHINE SHOP

ALBERT WATTS,
FOREMAN BOILER

DAVID THOMPSON,
SHIPPING CLERK.

STOVEL CO

MANY THOUSANDS

OF PEOPLE HAVE BEEN SAVED FROM POVERTY AND DISTRESS BY A POLICY OF LIFE INSURANCE.

MANY THOUSANDS

OF PEOPLE HAVE SAVED MONEY TO SUPPORT THEMSELVES IN THEIR DECLINING YEARS BY A POLICY OF LIFE INSURANCE.

THE ACCUMULATION POLICIES ISSUED BY THE CONFEDERATION LIFE ARE FREE FROM CONDITIONS FROM DATE OF ISSUE AND GUARANTEE MOST VALUABLE PRIVILEGES AND BENEFITS TO THE INSURED.

WRITE FOR INFORMATION

CONFEDERATION LIFE ASSOCIATION

HEAD OFFICE : TORONTO, CANADA.

W. H. BEATTY, Esq.,
President.

W. D. MATTHEWS, Esq.,
Vice-Presidents.

FREDK. WYLD,

J. K. MACDONALD,
Managing Director.

W. C. MACDONALD,
Actuary.

BRITISH COLUMBIA LUMBER AND SHINGLE MANUFACTURERS

The Canadian Pacific Lumber Co., Limited

PORT MOODY, B. C.

Manufacturers and Wholesale
Dealers in All Kinds of

B. C. LUMBER, LATH, MOULDINGS, ETC.

The Largest Shed and Dry Kiln Capacity of any Mill in British Columbia.
Special Attention Given to Orders from Manitoba and the Territories.



Long Distance
Telephone Connection.



Address the Company at Port Moody or
BYRNES & CUDDY, Selling Agents, WINNIPEG.

CLOVERDALE MILLING CO., CLOVERDALE, B. C.

== Red Cedar Shingles ==

OUR SPECIALTY

CORRESPONDENCE SOLICITED

SECOND TO NONE

PETER LUND, Managing Director.

J. BRECKENRIDGE, President.

MANUFACTURERS OF
ALL KINDS OF

Grows Nest Pass Lumber Co., Limited

WARDNER, B. C.



BUILDING MATERIAL

Capacity 150,000 Feet Per Day.

THE KING LUMBER MILLS, LIMITED, GRANBROOK, B. C.

Manufacturers
of

Building Materials

And All Kinds of DIMENSIONS, FLOORING, CEILING and BASE and CASE MOULDINGS

Columbia River Lumber Company, Limited

HEAD OFFICE AT GOLDEN, B. C.

Largest Capacity in Mountains

MILLS AT

GOLDEN, B. C.
BEAVER, B. C.
KAULT, B. C.
CARLIN, B. C.

ROUGH AND
DRESSED

LUMBER

FIR, SPRUCE
CEDAR AND PINE

LATH

Telephone Poles,
Piling, Etc., a
Specialty.

The Fernie Lumber Co., Limited, Fernie, B. C.

MANUFACTURERS OF AND DEALERS IN ALL KINDS OF

ROUGH AND DRESSED LUMBER

Dimension and Bridge Timber a Specialty.

Moulding in Stock or Made to Order.

H. CAMERON, Manager.

DONALD GRANT, President.

Moyie Lumber & Milling Co., Limited, Moyie, B.C.

Manufacturers and Dealers in All Kinds of

FLOORING, CEILING, SIDING, SHIP LATH, COMMON BOARDS, DIMENSIONS AND LATH

Specialty: **MOUNTAIN TAMARAC**

JOS. GENELLE, Manager.

J. G. BILLINGS, Secretary.

THE YALE-COLUMBIA LUMBER COMPANY, LIMITED

Head Office: NAKUSP, B. C.

Mills at Nakusp, Westley and Cascade, B. C.

MANUFACTURERS OF

DEALERS IN

All Kinds Rough and Dressed Lumber,
Mouldings, Lath, Etc.

Cedar and Fir Piles, Telephone and
Telegraph Poles, Fence Posts, Etc.

BRITISH COLUMBIA LUMBER AND SHINGLE MANUFACTURERS

North Star Lumber Co., Limited, Cranbrook, B.C.

Manufacturers of PINE, FIR and TAMARAC LUMBER

Specialty: Heavy Timber and Piling

D. & J. HADDEN, CLOVERDALE, B.C.

MANUFACTURERS AND DEALERS IN THE HIGHEST GRADE

LUMBER AND RED CEDAR SHINGLES

Send your orders to the above firm, who can supply you with shingles that cannot be beaten for quality and prices.

Agent for Ontario: Woodstock Lumber and Manufacturing Co., Woodstock, Ont.

BIG BEND LUMBER CO., LIMITED, ARROWHEAD, B.C.

Manufacturers of Lumber, Lath and Shingles

CORRESPONDENCE SOLICITED



THE PIGEON RIVER LUMBER COMPANY PORT ARTHUR, ONT.

MANUFACTURERS OF

Band Sawed White Pine Lumber, Lath, Pine and Cedar Shingles,

are operating their extensive plant night and day, to keep abreast with orders.

THERE IS A BECAUSE—
A trial order will tell you why.

Winnipeg Representative,
D. J. McDONALD, Clarendon Hotel.

Robinson McKenzie Lumber Co., Limited

Cranbrook, B.C.

... MANUFACTURERS ...
... OF ALL KINDS OF ...

Rough and Dressed Lum-
ber, Mouldings, Casings,
and Lath



copyright—

P. O. DRAWER H

EAST KOOTENAY LUMBER CO., LIMITED

Capacity 150,000 feet per day.

Saw and Planing Mills at RYAN, CRANBROOK and JAFFRAY.

— WE MANUFACTURE —

TAMARAC
PINE and FIR

FOR THE NORTH-WEST TRADE

Send us your orders if you want dry stock.

Head Office: CRANBROOK, B. C.

D. B. GRANT.

T. W. KERR

Delta Saw Mill Co.

MANUFACTURERS OF

Rough & Dressed Lumber, Lath, Shingles,
Fence Pickets, Doors, Sash, Mouldings,
Salmon and Fruit Boxes, and Round Tanks

Correspondence Solicited. - - LADNER, B. C.

Mouldings

Shingles

VICTORIA LUMBER AND
MANUFACTURING CO., LIMITED

MILLS AT CHEMAINUS, B. C.

FIR AND CEDAR LUMBER

of all descriptions, in straight or mixed cars.

We can supply large and long timbers, but
don't care to ship anything over 40x40x140
feet long. : : : : :

Prompt Shipments
Good Quality and Manufacture
Long Lived Timber

ADDRESS—
CHEMAINUS, B. C.

BRITISH COLUMBIA LUMBER AND SHINGLE MANUFACTURERS

Canadian Timber & Saw Mills, Limited, Trout Lake, B. C.

MANUFACTURERS OF ALL KINDS OF

ROUGH AND DRESSED LUMBER

Specialties: Clear Cedar and High Grade Cedar Shingles

Send on Your Orders to the Above Company.

Prompt Shipments Guaranteed.

Capacity: 60,000 feet per day; 80,000 Shingles.

J. A. SAYWARD

MANUFACTURER OF AND DEALER IN

Cedar and Spruce Lumber

Shingles, Lath, Spars, Etc.

ORDERS CAREFULLY EXECUTED
PROMPT SHIPMENTS

VICTORIA, B. C.

THE BRITISH COLUMBIA MILLS, TIMBER & TRADING COMPANY

Head Office: VANCOUVER, B. C.

Winnipeg Office: Merchants Bank Building P. O. Box 235

MANUFACTURERS OF

BRITISH COLUMBIA FIR, CEDAR and SPRUCE—both Rough and Dressed. Sash, Doors, Mouldings, Lath and the Highest Grades

"ROYAL CITY BRAND"

RED CEDAR SHINGLES

DOUGLAS FIR TIMBER

All Widths and Thicknesses up to 120 feet in Length Supplied on the Shortest Possible Notice.

HASTINGS SAW MILL - VANCOUVER, B. C.
ROYAL CITY SAW MILL, VANCOUVER, B. C.

ROYAL CITY SAW MILL, NEW WESTMINSTER, B. C.
MOODYVILLE SAW MILL - BURRARD INLET, B. C.

OWNERS AND OPERATORS OF
Total Capacity, 400,000 Feet of Sawn Lumber per Working Day of Ten Hours.

The Ladysmith Lumber Co., Limited

LADYSMITH, B. C.

Manufacturers of

LUMBER, LATH, SHINGLES,
MOULDINGS, ETC.

SPECIALTY: The best Cedar Shingles manufactured on the Coast.

FRESH WATER FIR LATH ALWAYS IN STOCK.

Capacity of Shingle Mill, 100,000 per day of 10 hours.

Correspondence Solicited

GREAT NORTHERN LUMBER CO., LIMITED

Our Specialty

Pacific Coast Red Cedar Lumber

Expertly Manufactured and Culled.

Correspondence Solicited.

ADDRESS:

R. D. RONSON, General Manager.

Vancouver, B. C., Room 19, Inns of Court

Scribner's Lumber and Log Book

A handy book for Lumbermen. Gives Correct Measurements of Scantlings, Boards and Planks; Cubical Contents of Square and Round Timber; Doyle's Rules, and much other practical information.

ADDRESS

Price 35 Cents

THE CANADA LUMBERMAN, Toronto, Ont.

WE WISH YOU ALL A

Glen Cove Six Roll

The Heaviest, Strongest and Most Powerful Timber Sizer on the market, yet capable of a wide range of work ; from dressing timber the full capacity of the machine, to running flooring, decking, car sills and other similar work.

All changes are quickly and easily made, thereby causing no loss of time when changing from one class of work to another.

Provided with Divided Rolls, also Power Hoist for raising and lowering the top cylinder and feed rolls. The rolls before the cut can be raised independently to take care of stock of unusual variation in thickness.

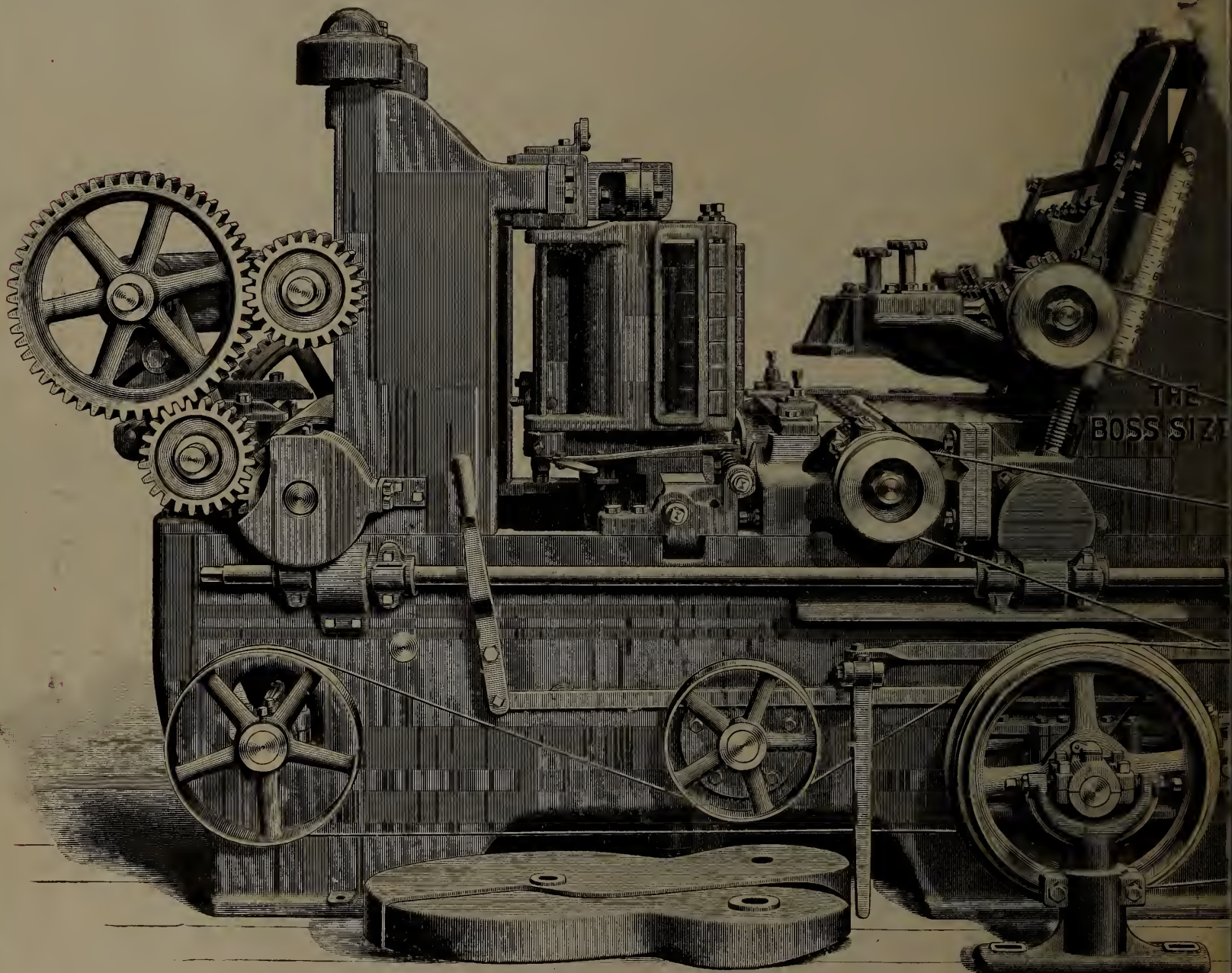

As a Six Roll Machine Built to Work 30

American Wood

Sales Agent, British Columbia : The Fairbanks Co., Vancouver



MAY IT BE A

PROSPEROUS NEW YEAR

Boss Timber Sizer

To change from slotted side heads to matcher heads requires only the removal of the top box, when the heads may be taken off and the matcher heads substituted. Suitable top and side pressures are provided for matching. The feed rolls are large in diameter, strongly geared at both ends, independently weighted, and rise and fall parallel with the bottom rolls. Friction Clutch is provided to start or stop the feed, but will furnish tight and loose pulleys if desired. There are six rates of feed, from 25 to 60 feet per minute.

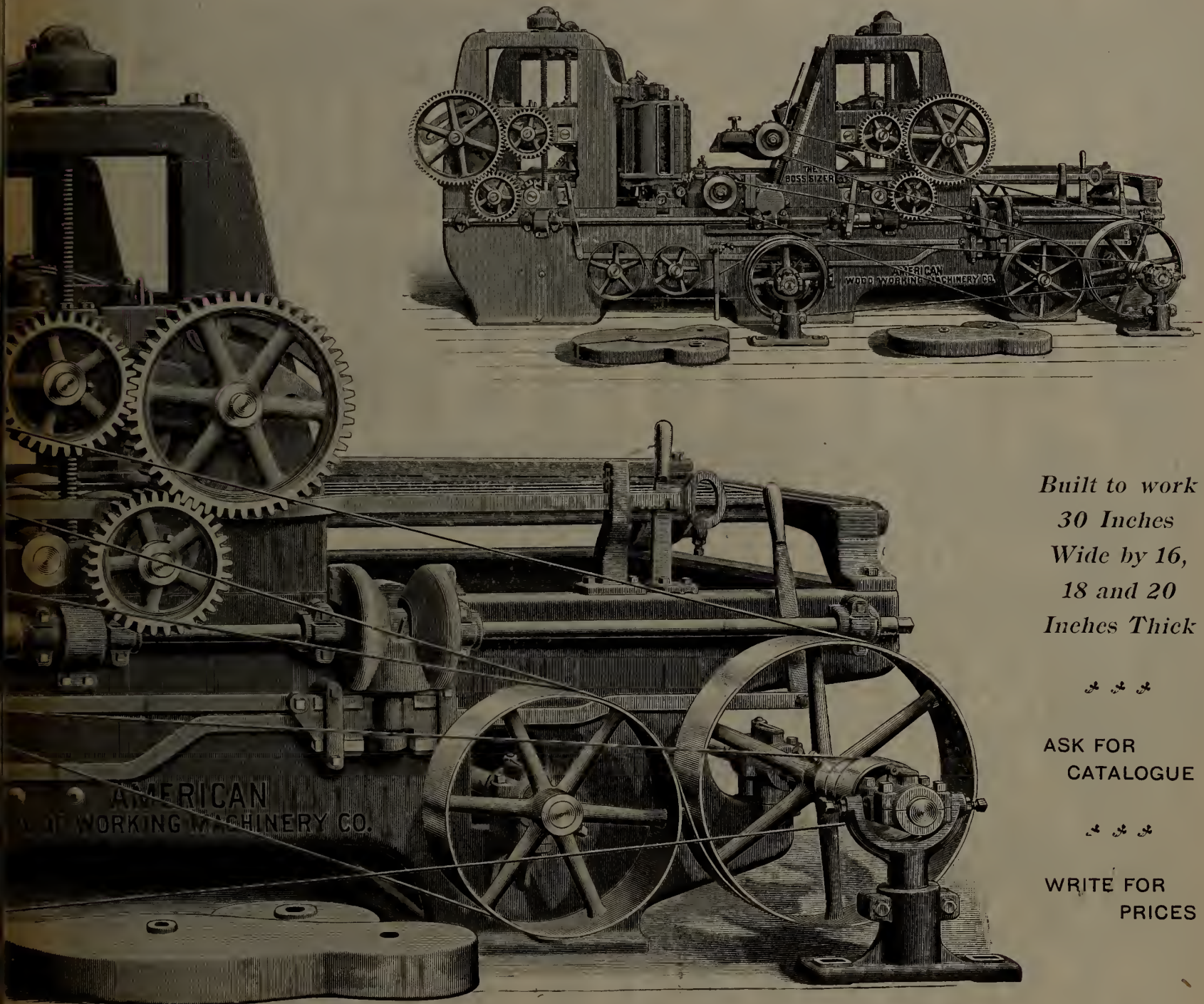

*Built to work
30 Inches
Wide by 16,
18 and 20
Inches Thick*



ASK FOR
CATALOGUE



WRITE FOR
PRICES

Inches Wide by 12 or 14 Inches Thick.

Working Machinery Co.

NEW YORK: 136 Liberty Street

"RED LETTER" ONE



SOMETHING
NEW
IN
LEATHER BELTING

“AMPHIBIA”

**GUARANTEED
ABSOLUTELY WATERPROOF
FOR**

**SAW & PULP MILLS
& ALL WET PLACES**

*WRITE FOR
DESCRIPTION & PRICES*

SADLER & HAWORTH
TANNERS & MFRS.,
MONTREAL — TORONTO.

JOSHUA OLDHAM & SONS

ESTABLISHED 1870.

NEW YORK SAW WORKS

The Oldham Saws for Sawmills

BRIDGE OVER THE CARES, AND LEAVE



PLEASANT REFLECTIONS OF
SUCCESSFUL LUMBER PRODUCTION

JOSHUA OLDHAM & SONS

NEW YORK SAW WORKS

BROOKLYN BOROUGH
NEW YORK

New 200 Page Green Book
1904 EDITION.
"Saw and Knife Fitting
Machinery and Tools"

MAILED FREE ON REQUEST.

A Book for Mill and Factory Managers,
Superintendents, Foremen and Saw Filers.

BALDWIN, TUTHILL & BOLTON,
GRAND RAPIDS, MICH., U.S.A.



B. T. & B Full Automatic Knife Grinder. Style D

SAW AND KNIFE FITTING
THE NEW B. T. & B. MANUAL

Revised edition. 144 pages. Copiously
illustrated and Durably Bound. Is an exhaustive
treatise on the care of Saws and Knives.

A Practical Book for Saw Filers.

Mailed Postpaid on Receipt of Price
\$2.00

**THE "B. T.
& B." LINE**

NEED ANYTHING ?

- Sharpeners, Swages,*
- Stretchers, Shapers,*
- Side Files, Shears,*
- Retoothers, Brazing*
- Machines, Filing*
- Clamps, Lap*
- Grinders, Lap Cutters,*
- Patch Machines,*
- Crack Drills,*
- Hammering Benches,*
- Bench Grinders,*
- Band Filers,*
- Band Setters,*
- Pulleys and Stands,*
- Brazing Forges,*
- Saw Sets, Saw Gauges,*
- Swage Bars, Upsets*
- Straight Edges,*
- Tension Gauges,*
- Back Gauges,*
- Leveling Blocks,*
- Anvils, Hammers,*
- Speed Indicator*
- Emery Dressers,*
- Knife Grinders,*
- Knife Balances,*
- Shingle Saw Grinders,*
- Burr Gummers,*
- Post Brackets,*
- Stretcher Bench*
- Brackets, Cutters,*
- Marking Stamps,*
- Saw Guides, etc.*

Andrews
Stands for
Three Comforts
Quality Efficiency Price



Kilns That Dry Your Lumber
Without Drying Up Your Bank Account

Write for Catalogue

The A. H. Andrews Co.
174-176 Wabash Avenue - - CHICAGO, U. S. A.

THE SCHAAKE MACHINE WORKS

NEW WESTMINSTER, B. C.

Builders of a Complete Equipment of

Saw^{and} Shingle Mill Machinery

SOLE MANUFACTURERS OF

Johnson's Improved Upright Shingle Machines

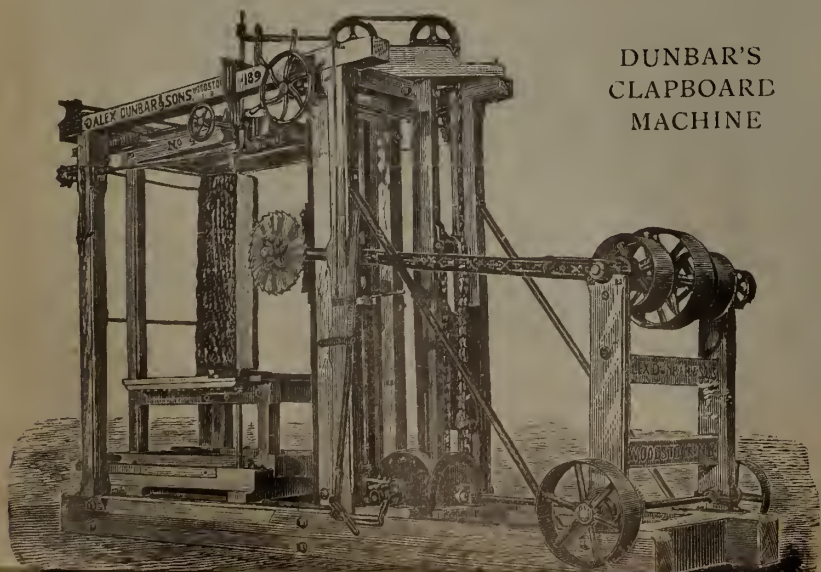

DUNBAR'S
CLAPBOARD
MACHINE

ALEX. DUNBAR & SONS
Woodstock, N. B.

Manufacturers of

Saw Mill Machinery
OF ALL KINDS

Including ROTARY SAW MILLS (3 sizes), CLAPBOARD SAWING
MACHINES, CLAPBOARD PLANING AND FINISHING MACHIN-
ERY, SHINGLE MACHINES, STEAM ENGINES, Etc.

WRITE FOR FURTHER PARTICULARS

ALEX. DUNBAR & SONS - Woodstock, N. B.

E. H. HEAPS & CO.

Cedar Cove Mills:
VANCOUVER, B. C.

Ruskin Mills:
RUSKIN, B. C.

MANUFACTURERS OF

Lumber
Lath
Shingles
Doors
Mouldings
Etc.

SPECIALTIES:

AA1 HIGH GRADE CEDAR SHINGLES

Cedar Bevelled Siding, Cedar Door and Sash Stock, cut to size, Cedar Finish, Base, Casing, Newels, Balusters, etc. Douglas Fir Timber up to 85 feet in length.

CAR AND CARGO SHIPPERS

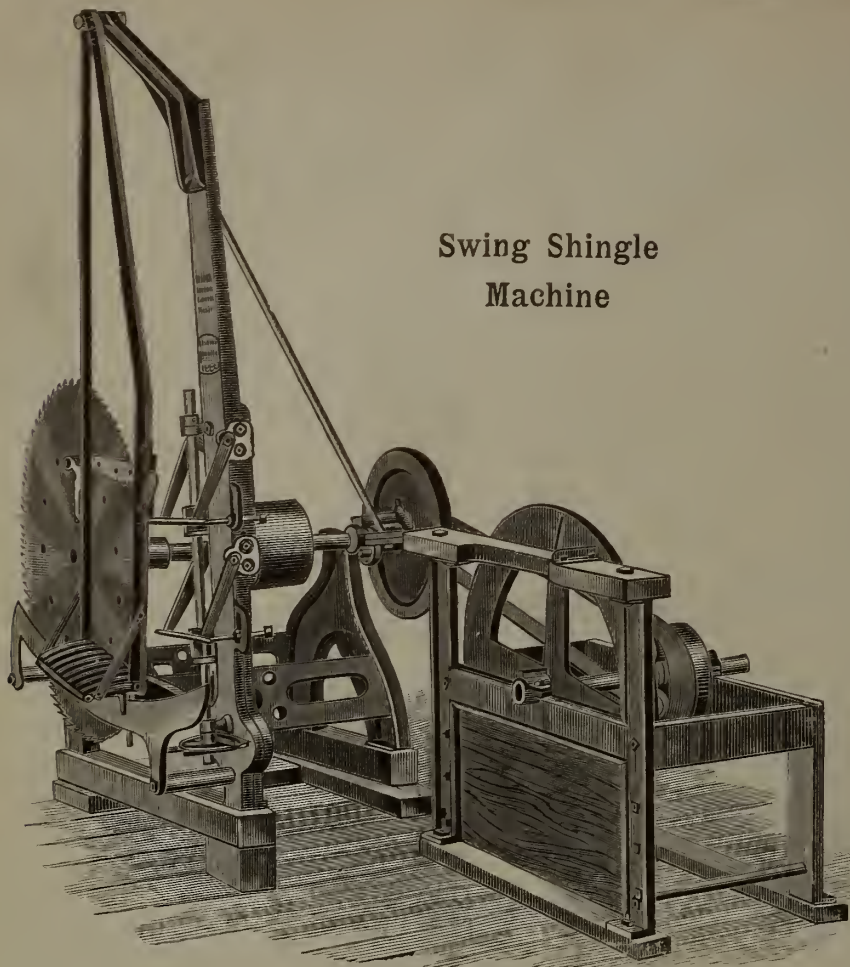

Swing Shingle Machine

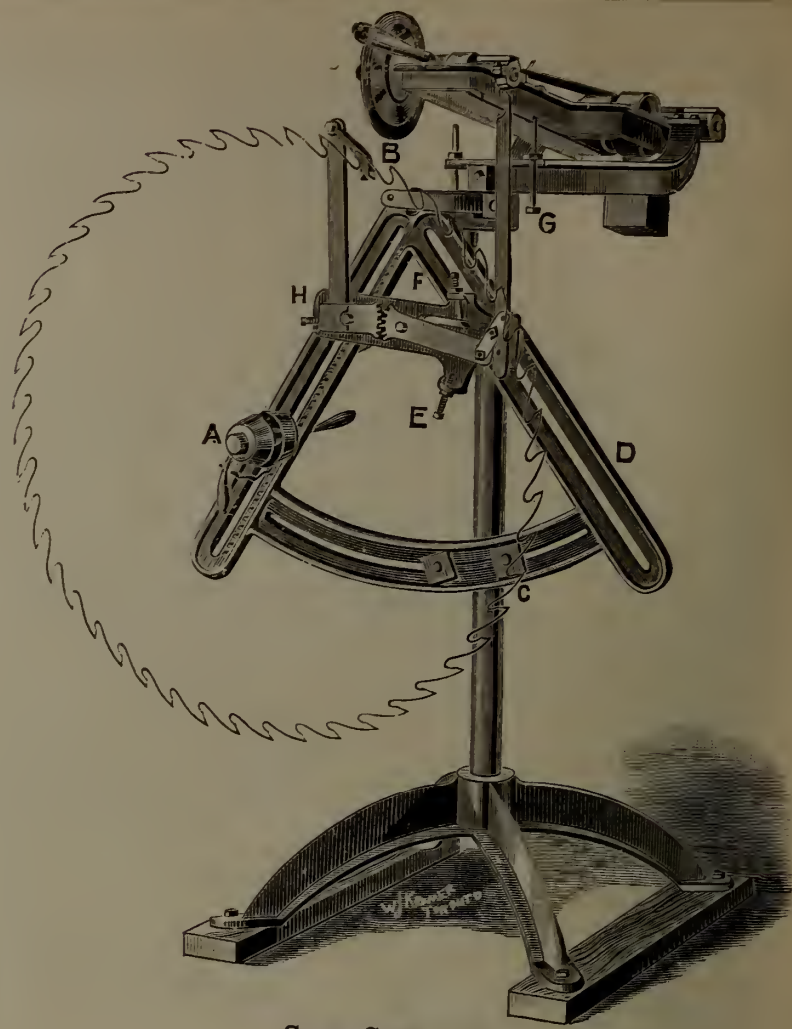

Saw Gummer

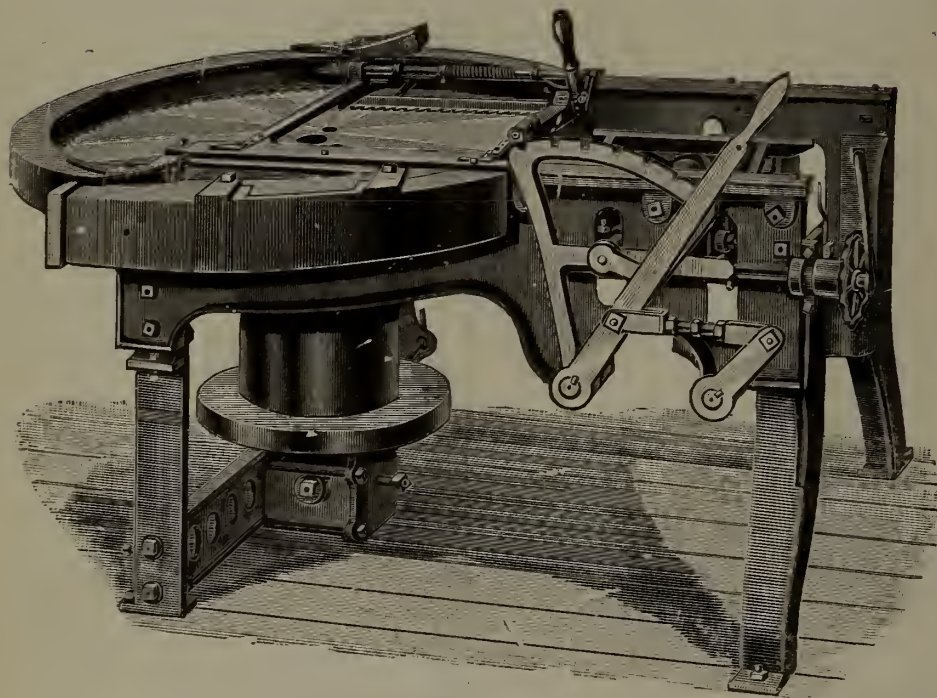

Dauntless Shingle Machine

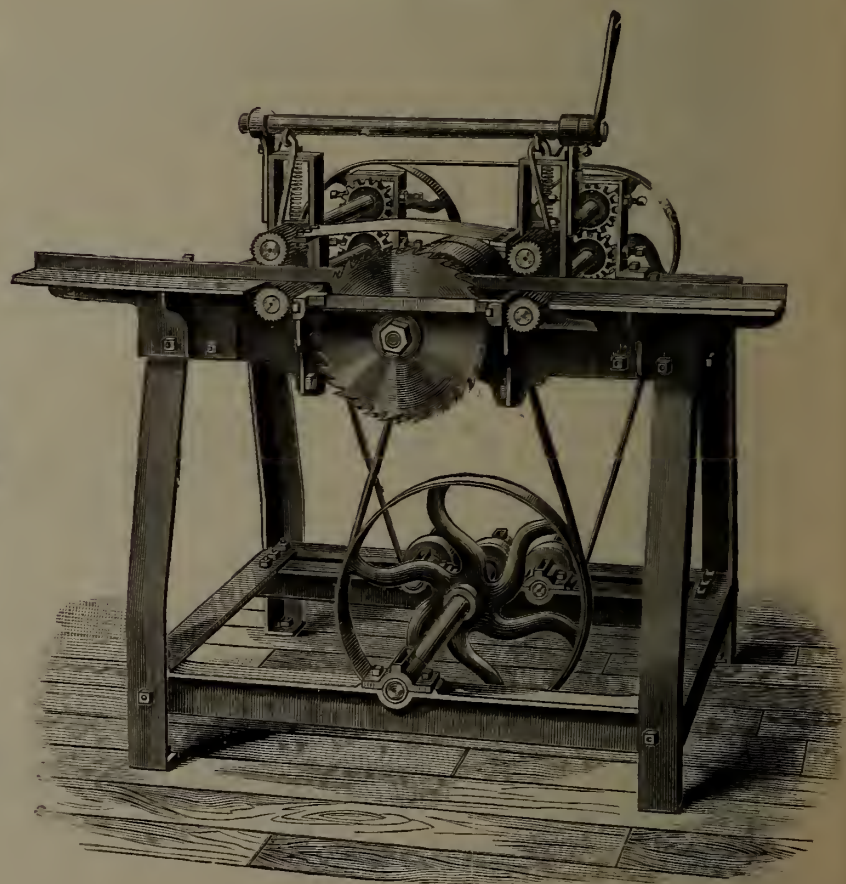

Lath Machine

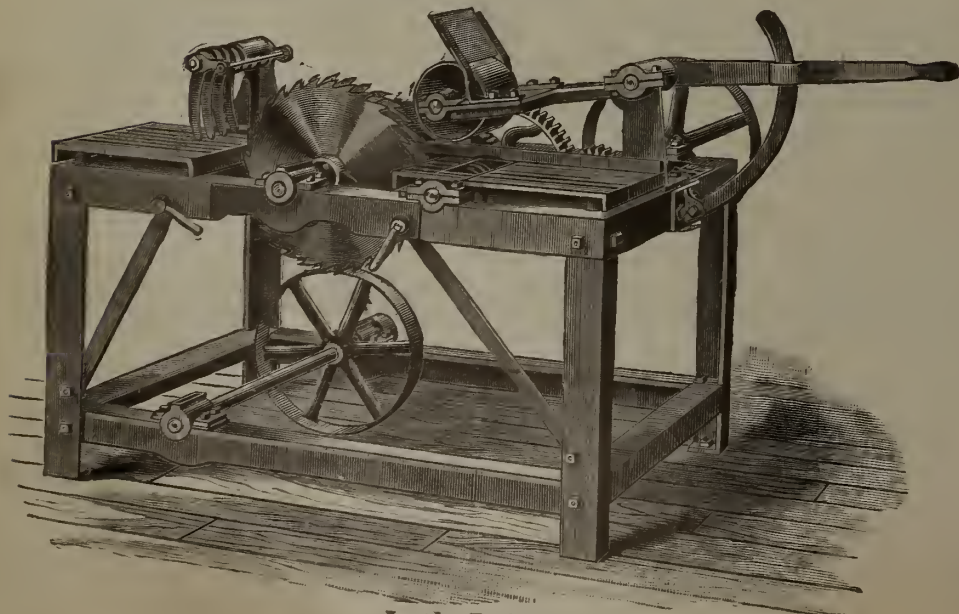

Lath Bolter

Get Our Latest Prices and Save Money . . .

F. J. DRAKE

BELLEVILLE, ONT.

COWAN & COMPANY of Galt, Limited Galt, Canada



BAND RESAW. M 107.

Wheels 60" diameter, to carry 7" Saw Blade. Lower Wheel Solid. Upper Wheel has Steel Locomotive Tire for Rim. Both have Rims Ground to Fit Steel Template. Feed is Strong and Powerful. Rolls recede 8 inches to right and 12 inches to left of saw blade and will split stock up to 32 inches wide. Rates ten to one hundred and fifty lineal feet per minute, controlled instantly by hand lever.

These Machines are Unequalled and we build them in different styles and sizes with 60", 54", 48" and 42" wheels.

We make the Best and Most Complete line of **Wood Working Machinery** in Canada. Our large line of Flooring Machines, Surface Planers, Moulders and Resaws, as well as of the Smaller Machines, mark us as the Leading Wood Working Machinery Manufacturers.

Write for Catalogue and Prices.

COWAN & COMPANY of Galt, Limited Galt, Canada

TEON BELTING



STEAM PROOF
WATER " "
HEAT " "
OIL " "
ACID " "

Stronger and Cheaper Than Leather

LEATHER BELTING CAMELS HAIR BELTING
CAPATA BELTING (BALATA TYPE) LACE LEATHER, ETC.

Special Arrangements for Trial Belts.

Write for Price List and Discounts.

P. H. WILBY

27½ Front Street East TORONTO
Phone Main 1930 SOLE AGENT FOR CANADA

WIRE ROPE



.. For all Purposes ..

LARGE STOCK CARRIED—CUT TO ANY LENGTH
Special Ropes for Lumbering

The Dominion Wire Rope Co., Limited
MONTREAL QUE.

STEAM BOILERS



Portable Boilers—Locomotive Style
Return Tube Tubular
Tanks, Water Towers, Smoke Stack, etc.

CANADA FOUNDRY COMPANY, LIMITED

Head Office and Works: TORONTO, ONT.

District Offices: Montreal Halifax Ottawa Winnipeg Vancouver Rossland Calgary

ENGINEERS FOUNDERS MACHINISTS

BUHL MALLEABLE
COMPANY,
DETROIT, MICH.

Elevating, Conveying and Power
Transmitting Machinery

SPROCKET CHAIN AND WHEELS

MALLEABLE OR STEEL BUCKETS

We Guarantee our Goods to be of Standard
Design and Unexcelled Quality.

Belt Conveyors and Spiral Steel Conveyors

MONTREAL TORONTO VANCOUVER WINNIPEG



Garlock Packing Co.

HAMILTON - - - CANADA

—SOLE MANUFACTURERS OF—



GARLOCK'S PACKINGS

PATENTED

Asbestos and Mineral Wool Pipe and Boiler
Coverings, Engineers' Supplies in General



THE CANADA LUMBERMAN

VOLUME XXV.
NUMBER I.

TORONTO, MONTREAL, WINNIPEG, CANADA, JANUARY, 1905

TERMS, \$1.00 PER YEAR
Single Copies, 10 CENTS

THE ADMINISTRATORS OF CROWN TIMBER LANDS.

In the group photograph shown on this page may be seen the portraits of the gentlemen in whom is vested the administration of the Crown timber lands of Canada.

Hon. Clifford Sifton, as Minister of the In-

terior Government and passed over to the Provincial Government as swamp timber lands. These have been controlled by Hon. R. P. Roblin since the death of Hon. J. A. Davidson, Commissioner of Provincial Lands, some months ago.

Hon. A. G. Mackay has but recently been ap-

pointed last summer of Hon. A. T. Dunn as Collector of Customs at St. John. Since that time Hon. L. J. Tweedie, Premier of the Province, has been Acting Surveyor General, but it is expected the portfolio will be filled at a very early date.

The timber lands of Nova Scotia have near-



ADMINISTRATORS OF THE CROWN TIMBER LANDS OF CANADA.

(1) HON. CLIFFORD SIFTON, Minister of the Interior for Canada.
(2) HON. R. F. GREENE, Commissioner of Lands and Works for British Columbia.
(3) HON. R. P. ROBLIN, Commissioner of Provincial Lands for Manitoba.

(4) HON. A. G. MACKAY, Commissioner of Crown Lands for Ontario.
(5) HON. J. W. LONGLEY, Commissioner of Crown Lands for Nova Scotia.
(6) HON. J. L. TWEEDIE, Acting Surveyor-General for New Brunswick.
(7) HON. S. N. PARENT, Commissioner of Lands, Forests and Fisheries for Quebec.

terior, is the controller of the Dominion lands in Manitoba and the Northwest Territories and within the Railway Belt of British Columbia.

In the Province of Manitoba there are about 300,000 acres of timber lands controlled by the Provincial Government, these being nearly all east of Winnipeg on the Canadian Pacific and Canadian Northern Railways and consisting of lands that have been surveyed by the Do-

pointed to the office of Commissioner of Crown Lands for Ontario, succeeding Hon. E. J. Davis, who resigned on the reorganization of the Cabinet. Mr. Mackay is a prominent lawyer of Owen Sound and was appointed K.C. in 1902, in which year he was first returned to the Legislature.

The office of Surveyor General for New Brunswick was made vacant by the appoint-

ly all passed out of the control of the Provincial Government and are held by the owners in fee simple. Hon. J. W. Longley is the Commissioner of Crown Lands.

A. McKillop & Sons, Limited, is the name of a new company organized at West Lorne, Ont., to operate a saw mill, bending factory and woodworking plant.

EARLY HISTORY OF "THE CANADA LUMBERMAN"

By E. J. TOKER.



E. J. TOKER.

THE CANADA LUMBERMAN was founded by Mr. Alexander Begg, the well known writer, in the year 1880, the first number, which was published in Toronto, being dated October 15th. In his introductory he says: "Though much attention

has been given to the lumbering interests by the press of Canada, yet it is felt that a special organ, which would concentrate the views of those who understand the business and present them to the public in a way in which they could be fairly discussed, with a full comprehension of the value of the vast interests involved, would not merely serve those who are engaged in the trade and their employees, but also the country at large. Let it be remembered that the lumbering interest is the second greatest in Canada—being next to the agricultural. . . . It would be out of place in this introductory to enter into details as to the vast resources of Canada as a timber producing country. It has not infrequently been sneered at as a "wooden country," and the taunt is neither without foundation nor is it one to be ashamed of. Canada is indeed a wooden country, but its woods are fast disappearing, and one of the prime elements of its early growth is being ruthlessly destroyed, by the old style of management on the part of the Government and the reckless indifference of the people. It will be the duty of THE LUMBERMAN to point out the injuries annually inflicted on the wooden wealth of Canada by reckless tree felling and the still more reckless starting of forest fires whether by sportsmen or settlers. Even in the latter particular our journal may, by assisting in arousing public opinion, be the means of saving millions of dollars to the country in a single year."

Before six months had elapsed Mr. Begg sold THE LUMBERMAN to Messrs. Toker & Company, the publishers of the Peterborough Review, the firm consisting of Mr. E. J. Toker, now Secretary-Treasurer of the Peterborough Review Printing and Publishing Company, and editor of the Review, and Mr. John Carnegie, formerly M. L. A. for West Peterborough. By this firm the CANADA LUMBERMAN was published in Peterborough for over five years, their first number being issued on March 15th, 1881. In the introductory article promise was made that "It will contain those accurate statistics which are necessary to the trade as a basis for intelligent operation. Not only will the markets with which the trade have to do be carefully reported, but the most trustworthy information possible will be obtained from each locality of the production of timber and lumber, and of

the stock in hand. We will aim not only at advocating any measure that may be for the advantage of the lumbermen, but at affording a means by which they may express their wants and wishes or exchange ideas on subjects of interest to them. By this means we also hope that their mutual action may be facilitated."

It was also promised in this introductory article that "THE LUMBERMAN will advocate the establishment of a 'Bureau of Woods and Forests' in connection with the Provincial Government. It is generally admitted that the interests of the Provincial Treasury are identical with those of the limit holders, and there is room for legislation to protect the public revenue while at the same time guarding the vested rights of the timber licensees. Unfortunately, in the past legislation has brought the settler and the lumberman into antagonism. Without discussing how this has been brought about, it will be a leading object of this paper to uphold that purely timber areas should not be open to settlement until the timber has been exhausted. To determine and locate these timber areas is a matter that should be dealt with at once by the proposed Bureau of Woods and Forests. . . . The process might be that in the first place all the wild land should come under the supervision of the Bureau of Woods and Forests—their dictum being obtained as to what portions should be reserved for lumbering operations; those lands excluded by them as not strictly fulfilling the conditions of a timber area should then be dealt with by the Crown Lands Department and exposed for sale from time to time as might be deemed advisable. Unfortunately, in the past succeeding Ontario administrations have thrown into the market large areas of timber limits purely and simply for the purpose of creating surpluses, which has given them a great deal of trouble to dispose of to the general satisfaction of the different parts of the Province. Had the evil stopped here, however, it would not have been so bad, but as the public are aware, there is a sort of fictitious settlement that invariably follows the track of the lumberman and will continue to do so if the lands are open for sale. It is generally the fictitious settlement that has originated those large fires which have destroyed, as it is claimed, almost a third part of the pine timber of Ontario. The course we suggest for dealing with this question would reduce the fire risk to a minimum. The plantation of new forests would also properly come under the jurisdiction of the Bureau of Woods and Forests."

After an experience of about five and one-half years, Messrs. Toker & Company, finding that they were unable to do justice both to the CANADA LUMBERMAN and the Peterborough Review, sold THE LUMBERMAN to Mr. A. G. Mortimer, who continued to publish it in Peterborough until September, 1886, when he removed the office of publication to Toronto. In April, 1894, Mr. A. G. Mortimer transferred

the journal to the present publishers, who have been able to devote more attention to it, and under their management it has more fully carried out the intentions of their predecessors. It has been improved and enlarged till it is now recognized by the lumbering and allied industries as a satisfactory representative of their interests.

OLD DAYS IN PETERBOROUGH.

In the days when the CANADA LUMBERMAN was first published in Peterborough the town and district was a lumbering centre of considerable importance. The hiring and assembling of men for the shanties, and still more their return in the Spring, and that of the river drivers at a later date, enlivened the town in a manner that could not fail to attract attention. The supplies for the lumber camps were an important portion of the business of our townsmen, and put many a dollar into the pockets of our farmers. We have a considerable French population from some of the more prudent of the shantymen buying lots, building and establishing their families among us. The time had gone by a few years when square timber was one of the chief products of the forests of the district and when parties used to go ten miles up the river to Lakefield to have the excitement of the run down the almost constant rapids on a timber raft. But huge drives of sawlogs were a marked feature on our rivers and lakes. Wherever there was a suitable site on these waters, celebrated for their abundant water power, there was a saw mill in full operation.

In Peterborough on the Little Lake was a steam saw mill run by Mr. McDonald. It was afterwards burned, when Mr. McDonald purchased from the Bank of Commerce a larger steam mill at Nassau, which had only been run a short time, and removed it to the Little Lake.

On the river in the centre of the town front was the fine saw mill of the Dickson Company, the property of the heirs of the late Mr. Samuel Dickson, who was killed by the breaking up of his dam by the heavy floods in the spring of 1870. The business was for many years under the management of his son-in-law, the late Mr. T. G. Hazlett. The site and the fine water power are now occupied and used by the Cereal Company, the Dickson Company having, as elsewhere mentioned, made other arrangements for cutting the logs from their extensive limit. The Peterborough Light and Power Company is also served by this dam. A little way up the river at Auburn was the saw mill of the late Mr. George Hilliard, afterwards M. P. for West Peterborough. The power here is now used by the Auburn Woolen Company for their extensive factory.

Close above had been the saw mill of Mr. William Snyder, but it had ceased running long before 1881. The power here was acquired by the Peterborough Waterworks Company, now owned by the town and operated for fire protection and domestic use.

Further up the river at Nassau was the Red Mill, which was built and first owned by the late Mr. Charles Perry, M. P. for West Peterborough. He was succeeded by Messrs. Campbell & Houston, who had extensive limits in the district, till the senior partner, Mr. A. H. Campbell, the well known lumberman, removed to Toronto, thence conducting his business to the northward. It subsequently was acquired by Messrs. Boyd, Smith & Irwin, and after the death of Mr. Smith was operated by Messrs. Irwin & Boyd, who were running it at the time THE LUMBERMAN was founded. Mr. Gardner Boyd, who was the eldest son of Mr. Mossom Boyd, of Bobcaygeon, subsequently left the business, which was continued by Mr. J. M. Irwin alone. Mr. Irwin erected a new steam saw mill on the down side of the river opposite the Red Mill, and this, as we have said, was afterwards bought by Mr. McDonald and removed to Peterborough. The Red Mill was broken up for its material. The power is now used by the Canadian General Electric Company for their very extensive works in Peterborough.

About half a mile up stream on the first dam above the Nassau dam is the building of the Otonabee Power Company, from which electric power is conveyed to Peterborough. Nearly two miles further up is the power house of the Lakefield Cement Company, from which power is conveyed to Lakefield. Some nine miles up the river from Peterborough, at the Village of Lakefield, was the fine saw mill with excellent water power then run by the Messrs. Strickland. The property has been acquired by the Dickson Company, who are cutting there as well as at their new mill on the Little Lake, Peterborough. There is also at Lakefield a new steam saw mill run by Messrs. Tate & Lillicrap, and besides the grist mills of Mr. John Hull and Mr. McAlister, there is Mr. T. J. Moore's planing mill.

At Young's Point, at the foot of Clear Lake, was a small saw mill run by the Youngs, which was taken down when the power house was built. The Lakefield Cement Company, with its large output, derives its power from this dam, which is used in connection with the

power down the river already mentioned to run the cement works.

At Bridgenorth, on Chemong Lake, was a small steam saw mill then run by Mr. Kelly, as it still is by his son. On the same lake there is a small saw mill operated by Mr. Brunwell.

At Buckhorn was the mill of Mr. N. Shaw, afterwards owned by the late Mr. W. H. Hall. It has not been used for many years and has

ing on a large scale in British Columbia.

At Felon Falls, between Pigeon and Cameron Lakes, was the saw mill of Mr. R.C. Smith. Messrs. Green & Ellis and Hilliard & Mowry also had mills at Felon Falls. Now these mills have all been removed, but the Rathbun Company have a mill at the Falls.

Going down the Otonabee River Messrs. McDougall & Ludgate and Ulyott & Saddler had two large saw mills at Harwood on the south shore of Rice Lake, but they have been removed. Mr. Burnett now has a saw mill on the north shore of the same lake.

Fowlds Bros. have a saw and grist mill at Hastings on the River Trent, which is a continuation of the Otonabee with the change of name.

It will have been seen from this brief retrospect that at Peterborough, on the Otonabee River and on the magnificent chain of the Kawartha Lakes, there was much lumber cut from the extensive pine limits tributary to these waters. Many of these mills are now closed and have been succeeded by other industries. This is the route of the Trent Canal now under construction as a means of transportation for the harvest of the great western prairies to the St. Lawrence ports. At Peterborough there has been constructed a hydraulic lift lock, the largest in the world and unique in its design.

The days of which we have been speaking have gone by. Mills that have been burnt have not been rebuilt. Their sites have been otherwise occupied and the water power has been turned to other uses. Peterborough is no longer a lumbering centre. There is a considerable cut by the Dickson Company at Lakefield and by them and the McDonald Company on the Little Lake, an enlargement of the Otonabee River situated within the town, but most of the logs, which still pass us in great numbers, are on their way to the mills of the Gilmours at Trenton and the Rathbuns at Deseronto.

With the lumbering the time is past when one could get slabs and edgings for fuel from the mills for the carting, as so much was thus saved from the carriage to the ever burning piles. Even the banks and bars of saw-dust which grew so rapidly and inconven-



VOL. I.—NO. 1.

TORONTO, ONT., OCTOBER 15, 1880.

PRICE FIVE CENTS.

INTRODUCTORY

In bringing before the public a new journal, specially devoted to lumbering interests, and incidentally to milling, manufacturing and mining, as being kindred forms of the development of the national industry, there is little apology needed. As there are special branches in trade, so there are special departments in journalism. The daily paper, morning and evening, rushes forth without regard or respect for any interest, but with an intention well formed to treat all fairly; and the result is a little general information here, a little special pleading there, and a large mass of the general gossip concerning things that occur upon the streets or elsewhere, but have very little practical interest for the business man, no matter what may be the branch in which he is engaged.

It is for this reason that specialists in journalism have in many cases achieved such remarkable success. Not to speak of the religious journals, whose existence depends on the zeal of the sects, there are others, such as the *Bullionist*, the *Scientific American*, the *Grocer*, &c., that represent special interests in trade and science, and they all receive a more or less generous support, from their own class—from those who are interested in the specialties they represent.

Though much attention has been given to the lumbering interests by the press of Canada, yet it is felt that a special organ, which would concentrate the views of those who understand the business, and present them to the public in a way in which they could be fairly discussed, with a full comprehension of the value of the vast interests involved, would not merely serve those who are engaged in the trade, and their employers, but also the country at large. Let it be remembered that the Lumbering interest is the second greatest in Canada—being next to the agricultural. Now, milling, mining and general manufacturing, naturally take a secondary and subservient position, as being dependent on the success and progress of the two great national industries—agriculture and lumbering. In proportion as they prosper, so will be the general prosperity of the country.

It would be out of place in this "Introductory" to enter into details as to the vast resources of Canada as a timber producing country. It has not infrequently been sneered at as a "wooden country, and the

tant is neither without foundation, nor is it one to be ashamed of. Canada is indeed a wooden country, but its woods are fast disappearing, and one of the prime elements of its early growth, is being ruthlessly destroyed by the old style of management on the part of the government, and the reckless indifference of the people. It will be the duty of the LUMBERMAN to point out the injuries usually inflicted on the woody wealth of Canada, by reckless tree-felling, and the still more reckless starting of forest fires, whether by sportsmen or settlers. Even in the latter particular, our journal may, by assisting in arousing public opinion, be the means of saving millions of dollars to the country in a single year.

But we are not ignorant of the great responsibility of starting this journal. Devoted as it is to a special class of operators, it must mainly look to them for support. It has not the whole of the reading community to appeal to directly, and hence must depend for success on the earnest and liberal support of those in whose interest it is published. Lumbermen, as a class, are noted for their public spirit and liberality, and we freely trust to their generous support as well as to that of lumber dealers generally. Nothing shall be wanting on our part to make this journal a full and complete record of the lumber business, and all that relates to the trade in Canada. To this end the latest market reports, the contributions of trustworthy correspondents, trade circulars, etc., will be freely used, to give our readers the best, the earliest, and the most reliable information that can be obtained, concerning the important branch of business to which the journal will be especially devoted; while the miners, the millers, and the manufacturing interests will receive attention proportionate to their great claims on the public.

In short, it will be our endeavour to make the LUMBERMAN worthy of its title in every respect; and, while giving special attention to the great staple industry to which it is devoted, it will also furnish a carefully selected amount of general reading that will make it a welcome visitor in every family.

Advertisers, especially those dealing in mill, mining, and lumbering supplies and machinery, will find the LUMBERMAN a very favourable medium of reaching their customers, as it will circulate among these classes, and receive more attention from them than they have the time or inclination to bestow on a general newspaper.

Watches.

Watches, by reason of their fragile construction, and the variations to which they are liable, can offer all only obtain a limited perfection in their performance; therefore, we must not be astonished to find them subject to certain variations. These variations, which are easy to correct, need not prejudice the quality of a watch, as will be proved by the following example. Two watches, we will suppose, have been put to the same time by an excellent regulator. At the end of a month, one of these watches is a quarter of an hour too fast; the other is exactly right to time. To which of these two watches would we give the preference? Perhaps to the one which is exactly right. But in making such a choice, we never think in our mind of abandoning a good watch for a bad one. The first watch, has, we assume, gained 30 seconds a day; and according to this rate, it has gained a quarter of an hour in 30 days. What must be done to make this watch go well? Alter the regulator inside from fast to slow, or get a careful watchmaker to do it for you, thereby altering its daily rate. Let us now admit that the other watch has been affected during a month by irregular going, which has occasioned it sometimes to gain, at other times to lose to a certain extent daily. It may easily occur that at the end of a month this gaining and losing compensate each other, and by this means the watch indicates the exact hour at the time we look at it. Such a watch can never be relied upon. The fact is that a watch which gains in a regular manner or loses in a regular manner is superior to any whose variation is uncertain, and whose rate varies comes to be familiar, the little companion may vie with the most delicately adjusted ship's chronometer. A skilful watch-maker one day thus reasoned with a customer who complained of his watch. "You complain," said he, "that your watch gains a minute a month. Well, then, you will co-operate yourself when you have heard me. You are aware that in your watch the balance, which is the regulator, makes five oscillations every second, which is 432,000 a day; so that your watch, exposed to all the vicissitudes which heat and cold occasion it, the varying weight of the air, and the shaking to which it is subjected, has not varied more than a minute a month, or two a ends a day. It has only acquired with each vibration of the balance a variation of the two hundred and sixteen thousandth part of a second. Judge then what must be the extreme perfection of the mechanism of this watch!" A watch can go for an indefinite period without being repaired or cleaned. At the expiration of a certain time, the oil dries up, dust accumulates, and wear and tear are the inevitable results to the whole machinery, the functions becoming irregular, and frequently ceasing to act together. A person possessing a watch of good quality, and desirous of preserving it as such, should have it examined every two years at least. But care should be taken to enable this cleaning or repairing to be careful hands; an incautious workman

may do great injury to a watch even of the simplest construction.

The Earth's Population.

In the new issue (No. 6.) of Behm and Wagner's well known "Bevolkerung der Erde" there are several points of fresh interest. Since the last issue, about two years ago, the population would seem to have been increased by about 17,000,000, the present population of the earth, according to Behm and Wagner, being 1,456,000,000, as against 1,439,000,000 two years ago. This, however, can not be set down to absolute natural increase, much of the addition being, no doubt, the result of new and more accurate statistics. The new issue has, for example, to take account of several new empires, some of them in countries where the population has not been accurately counted for many years, if at all. We have, for example, the census of Spain in 1877; Portugal, 1878; Greece, 1879; Bosnia and Herzegovina, 1879; New Zealand, 1878; Pern, 1876; Denmark, 1880, besides several smaller places. The total population is divided among the continents as follows: Europe, 315,929,000, or at the ratio of 32.5 per square kilometre; Asia, 834,707,000, or 187.4 per square kilometre; Africa, 205,579,000, or 6.9 per square kilometre; America, 950,495,500, or 2.5 per square kilometre; Australia and Polynesia, 4,031,000, or 0.4 per square kilometre; the remainder, 82,000, belong to the north polar region, mostly Iceland and Greenland. Although the census of the United States has been taken some months since, and a few of the data coaxed out in an irregular fashion, Herron Behm and Wagner have not made any use of the results, wisely preferring to await official statistics. They calculate that the census ought to give a result of at least 47,000,000. The editors have also given a fresh geometrical calculation of the area of Africa, yielding a result of 29,333,390 square kilometres. Of this area about six and a third million are forests and culture land, the same area savannahs and scattered woods, 1,500,000 bush, 4,200,000 steppes, and 10,500,000 desert. This last item seems appalling, but it should be remembered that much of the desert may be reclaimable, and that it includes large areas of fertile ocean. A new p anisometric calculation of the area of South America yields the result of 16,732,128 square kilometres, differing greatly from the sum of the official areas given by the South American governments.

Mr. F. B. Eddy, Ottawa, Ont., has taken a ten years' lease of the Lovejoy premises in Odgensburg, and will at once transfer them into a match and box factory. While there on Friday he let a contract of the value of \$1,200 to put the buildings into proper shape.

In E. C. Cane's mill, Cravenhurst, on Tuesday, Neil McMillen sawed, on one of Goldie & McCullough's machines, 42,600 of 16-inch shingles, within eleven hours. The shingles were jointed by Archibald McKinnon, and Edward Collis packed 32,900.

FACSIMILE OF FIRST PAGE OF FIRST NUMBER OF THE CANADA LUMBERMAN.

rotted down. On the Missasaga, two miles north of Buckhorn, was the saw mill operated by the late Mr. W. A. Scott, who had very extensive limits in the district. It was taken down by the Dickson Company, when they subsequently acquired the Scott limits.

At Bobcaygeon Village, between Sturgeon and Pigeon Lakes, was the fine saw mill of that well known lumberman, the late Mr. Mossom Boyd. At present it is owned by his sons, Mossom and William, under the old firm title of Mossom Boyd & Company. They have now nearly ceased to operate, their limits being exhausted, but they are lumber-

iently are now diminishing instead of increasing.

In those days the William Hamilton Company, the noted manufacturers of sawmill machinery, of course did a large local as well as outside business, but they can hardly miss the local work, so wide spread is the demand for their machinery, which is to be found in the largest mills in Ottawa and other parts of old Canada, and right away to the Pacific slope. There is also, it may be added, a large increase in the demand for their equally celebrated mining and hydraulic machinery.

Another local industry of importance has also its association with lumbering. Our well known canoes are used extensively by the lumbermen for their lighter work, and the factories consume large quantities of wood. A larger number of canoes are turned out in Peterborough than any other place and these little crafts are to be found almost throughout the civilized world. There are also canoe factories up the river at Lakefield with a large output.

In the eighties the late John Bertram had not become a lumberman on a large scale nor a strong advocate of conservative forestry, but was conducting a hardware business in Peterborough, which he at one time represented in the House of Commons. Mr. Bertram was here again recently as Chairman of the Transportation Commission to take evidence regarding the Trent Waterway.

Of course, the withdrawal of the lumbering business in a great measure from Peterborough was a loss to the town, but this did not cause a set-back, other industries taking its place, so that there has been continued progress. The old sites and the water powers have been made available for manufacturing purposes of even greater magnitude. For instance, the Cereal Company, with its enormous outputs of "Quaker Oats" and other breakfast foods, have built their immense works on the site of the old Dickson saw mill. The extensive General Electric works have utilized the excellent water power at Nassau of the old "Red Mill" where Messrs. Smith, Boyd & Irwin used to turn out the lumber from their extensive limits. The power at other dams which abound on the Otonabee have similarly been put to good use.

OUR FORESTS.

Looking back through this quarter of a century one cannot fail to be struck with the change in the value of our forests and of the output of the lumberman. Even those who have no connection with the business in any way, the general public, have been made aware by experience of the great increase in the price of lumber. That the value placed upon timber limits should have risen in proportion is a matter of course. Since THE CANADA LUMBERMAN came into existence the following have been the sales of limits by the Ontario Government:

Year.	Sq. miles.	Price.	Av. per mile.
1881	1379	\$733,675.00	\$532
1885	1012	318,645.00	305
1887	459	1,312,312.50	2,89
1890	396	346,253.25	874
1892	633	2,315,000.00	3,657
1897	159¼	265,162.50	1,665
1899	360	723,550.00	2,010
1901	399¼	732,787.50	1,835
1903	826	3,687,337.00	4,464

In this last sale the purchases of two lumbermen reached within \$16,000 of a million dollars between them, one of them, Mr. Thos. Mackie, of Pembroke, giving \$31,500 for a square mile of timber. It must also be remembered that the rental and stumpage dues have been raised considerably. This applies chiefly to pine, but the hardwood is also increasing in demand and in value.

A quarter of a century ago wood pulp for paper had hardly been heard of. Now it is a very important industry, being already of great magnitude and rapidly increasing. This is making great demands upon the extensive spruce forests of Ontario and other Provinces. So far paper for news and superior qualities is made almost entirely from spruce, other woods being little used as yet in Canada.

FORESTRY.

While it was published by Toker & Company, THE CANADA LUMBERMAN, as announced in its introductory, continued to advocate conservative forestry and the economical, far-sighted utilization of the woodland wealth of the Dominion, and this course has been maintained by the present publishers. The writer was asked more than once in those days how THE LUMBERMAN could venture to advocate so strongly and persistently the preservation of the forests, when its clients, the lumbermen, were the greatest forest destroyers. We were able to answer not only that we had heard no protests nor complaints, but that on the contrary we had received several expressions of approval; that in fact some of the strongest advocates of the preservation and the scientific management of our forests were to be found in the ranks of the lumbermen, as is also the case at the present day. It was uphill work to secure any adequate recognition of the importance of this subject. Any warning that our woodlands and especially our pine forests were not inexhaustible, that considerations of prudence dictated that they should be economized and conserved, were received with impatience by the general public, and consequently by the politicians. The growing interest is due to those early workers, with their arguments reinforced by the evidently increased scarcity and the rapidly enhancing value of our pine lands. THE CANADA LUMBERMAN may fairly claim that it has done its full share in this pioneer work.

The steps that have been and are being taken in the right direction in this matter are not a question of party politics, for if one party first suggested the setting apart of our forest lands as distinct from the agricultural districts, the prohibition of the exportation of saw logs and so forth, the other party has been able to take practical steps to forward the progress of this wise policy. The Dominion has established forest reserves and parks comprising nearly 10,000,000 acres, and both Ontario and Quebec have very extensive reserves. The announcement by the Ontario authorities of their intention of disposing of the timber on their reserves not by granting licenses for limits but by selling the right to cut selected trees, is also a step towards a less uneconomical system. Another movement in

advance is the steps being taken, far from complete as yet, to define our woodland areas and to estimate approximately the amount of the different kinds of timber and merchantable woods. Till this is accomplished we will not be in a position to deal intelligently with our still rich forest resources. Considerable attention is also being given to reforestation and new plantations. The Dominion has for some years been distributing to the settlers young trees from its model farms till the distribution has now reached the number of nearly 2,000,000 trees, and the Ontario Minister of Agriculture has announced his intention of following this good example by distribution from the Guelph Agricultural College. It is also in view to afford facilities for instruction in scientific forestry, and there is reason to hope that more than one of our Universities will make this addition to their curriculum. Altogether, we may look forward to means being taken to secure that Canada shall remain in perpetuity a country richly endowed with forest wealth.

A SIX-THOUSAND-YEAR-OLD CYPRESS.

The statement recently made that there are yews in England which are the oldest living things on this earth is not correct, says a writer in the St. Louis Globe-Democrat. These yews are old, very, very old; there is no doubt about that; some of them were stalwart trees even before Cæsar landed on those shores. There is one now standing in the churchyard at Fortingal, in Perthshire, which Decandole, nearly a century ago, proved to the satisfaction of botanists to be over twenty-five centuries old, and another at Hedsor, in Buclas, which is 3,240 years old. How Decandole arrived at an apparently correct estimate of the enormous age of these living trees is a simple thing, and the principle is doubtless well known to-day to all. The yew, like most other trees, adds one line, about the tenth of an inch, to its circumference each year. He proved this after an investigation extending over several years, and we know now, a hundred years later, that his deductions were correct. The old yew at Hedsor has a trunk twenty-seven feet in diameter, proving its great age, and it is in a flourishing, healthy condition now, like its brother at Fortingal. Their years are few, though, compared with those of the trees I had in mind when I made my first assertion that the statement printed about them in a scientific journal was incorrect. In one chapter of his writings Humboldt refers to a gigantic boabab tree in Central Africa as the "oldest organic monument" in the world. This tree has a trunk twenty-nine feet in diameter, and Adanson, by a series of careful measurements, demonstrated conclusively that it had lived for not less than 5,150 years. Still it is not the oldest organic monument in the world, as Humboldt declared, for now Mexican scientists have proved that a huge cypress tree, standing in Chapultepec, with a trunk 118 feet and 10 inches in circumference, is older than it—older, too, by more than a thousand years—for it has been shown, as conclusively as these things can be shown, that its age is about 6,260 years.

THE LUMBER INDUSTRY OF THE CANADIAN NORTHWEST

By J. L. CAMPBELL, Melita, Man.



J. L. CAMPBELL.

IN a prairie country one of the first requisites is lumber. So important is this commodity that construction trains will carry lumber into new districts even before the road is opened for general traffic. In this way the dealer gets in a few cars of his consignment in advance. From this small stock he builds a "shack" about twelve feet square and covered with tar-paper. The office fixtures comprise a bed (for his is perhaps the first building in the town), a store, a bundle of sash for a writing table and his inside pocket for a safe. With an indelible pencil and a note-book in his hip pocket he despises all the elaborate and wonderful systems of the modern accountant, and so with this very modest equipment he is prepared to do business with his customers.

This was the retail lumberman of Manitoba and the Northwest some twenty odd years ago. His stock was small and confined principally to the lower grades. The incoming settler in those days had neither the inclination nor the means to be fastidious. He was indeed lucky if he could get enough lumber transported to his far-off homestead for his very modest wants—a floor, a door and a window for his sod shanty, and a door and mangers for his stable built of the same unpretentious product of the soil. His orders were modest ones but his customers many and spread out over a district sometimes more than a hundred miles in extent. The supplies came practically all from the American side. Local manufacture was carried on for the most part in a very small way. Portable mills were employed to manufacture common boards and dimensions from the natural wood of the country, spruce and poplar. It was of indifferent quality, but in localities remote from the line of railway it sufficed to meet the modest needs of the settler.

During the eighties and early nineties, owing to the slow settlement of the country and the doubtful results of agricultural pursuits, not much advance was made in the lumbering business. The retailer struggled, not always successfully, sharing in the ups and downs, especially the latter, of the honest, brave, hardworking tiller of the soil, who first bore the forceful brunt of unexpected peculiarities of climate. The retail lumber business was carried on for the most part merely as an adjunct to some other. Stocks were meagre and badly kept, very little attention being given to protect even the upper grades from the damaging effects of wet and weather.

With a commendable faith in the future of the country, plants for the manufacture of lumber were being established along the railway

between Winnipeg and Fort William and in the wooded districts of Manitoba and the Territories north of the main line in different localities to the foot hills of the Rocky Mountains, and succeeded in supplying a large percentage of the trade of the country. In the eastern district the most important centre was Rat Portage, where several saw milling plants were established. These were not attended with great success. Too many separate organizations and too great an expenditure of antagonistic energy detracted largely from the resultant benefits. About ten years ago the various firms, excepting the Keewatin Lumber Company, amalgamated their interests. These were placed under the able management of Mr. D. C. Cameron. Such gratifying and substantial progress has been made that the Rat Portage Lumber Company occupies now the most important place in the West among what is called the pine manufacturers. One would not expect Winnipeg, situated as it is far from timber limits, to have any lumbering activity. But in this case the unexpected happens. Floating his logs down the Rosseau and Red rivers, Mr. D. E. Sprague supplies the material for a saw milling plant of surprising dimensions. Commencing in a small way when the city was younger he has kept pace with its marvellous growth, and having this nearby market for his output he has built up the largest local retail trade of any firm in Canada.

Coming to Brandon, we have the saw milling interests of the Hanbury Manufacturing Company. Some years ago this company took over the plant of the Assiniboine Lumber Company, with its spruce timber limits in Northern Manitoba. The logs are floated down the Little Saskatchewan to the Assiniboine river and thence to Brandon. Mr. John Hanbury has devoted his great energy and business enthusiasm to the expansion of this industry. He has added to it a woodworking factory which for completeness and efficiency is not surpassed in the country. Mention might be made of saw milling plants now operating in the timber districts extending across to the north of the prairie plains, but these three concerns, by virtue of their long establishment and conspicuous success, stand out prominently in the lumbering business of the West.

Since the early nineties and especially during the last six years, the North-West Territories have offered an ever increasing market for the large mills of the Coast. Modification of freight rates has enabled these mills to ship their products even to the far eastern parts of Manitoba. The construction of the Crows Nest Pass Railway has rendered possible lumbering in south-eastern British Columbia. A number of mills have been established here, finding a market in the rapidly growing districts of Southern Alberta.

During the period of expansion in the wholesale branch of the lumbering industry, the retailer of the West has been growing in importance. Conditions have changed greatly

in the last ten years. New districts fill up more rapidly than they used to do. Larger and more buildings are required. In the older districts, and indeed in some new districts too, the farmer no longer builds a shanty; he must now have a residence up-to-date in style and finish. Instead of a stable of poles and sod he builds stock barns magnificent in proportions and equipped with all modern devices. This great demand for quantity as well as ever increasing demand for quality, has made the retailer bestir himself to keep pace. Instead of stocks meagre and of indifferent quality they are now large and well assorted. His large lumber sheds systematically care for his material, preserving it in an improving condition. In the early days, with a few hundreds invested, he struggled precariously; now with thousands he is recognized in financial circles as a solid man.

An important factor in, and of parallel growth with this great expansion of the lumbering trade, is the Western Retail Lumberman's Association. The revival and well-being of the trade dates from its organization. Mr. Isaac Cockburn, the secretary, has been identified with the association for more than ten years. Though not present at its birth he rocked the cradle and did it well. With pardonable pride he regards the rapid growth and sturdy proportions of the institution as his "own bairn." Perhaps no man in Canada has had a larger or more varied experience in the lumber trade than he. To his wide experience and intimate knowledge he has added indefatigable enthusiasm and executive ability, so that during the last dozen years the membership of the association has increased ten-fold. With no notable exception it includes every wholesale manufacturer and retailer from the Great Lakes to the Rockies, as well as those very important manufacturers on the Coast. Under its influence the trade has been protected, its interests conserved, the wants of the public carefully met, financial accommodation extended to the purchaser with an unusual liberality, and all without unduly enhancing the price to the consumer.

What promises to have an important bearing on the trade has been the establishment of what are called line yards. Companies are formed to carry on business in grain and lumber. Along certain lines of railway, preferably new ones, they build a series of elevators for the handling of grain and establish lumber yards in connection with them, so that the one business is operated as the complement of the other. A local manager is placed in charge of each branch, who reports to his head office where the general business of the system is transacted. The plan seems to have advantages but has not been in operation long enough to furnish definite conclusions.

Generally speaking, twenty years ago the lumber industry was of obscure influence, now it takes front rank in the business economy of the country and none is more closely identified with its progress.

PIONEER LUMBERMEN WHO ARE STILL WITH US



HON. J. K. WARD.

In respect to number of years and achievement of commercial success, the gentleman whose portrait appears first on this page stands as an illustrious example among the pioneer lumbermen of this Dominion. Sixty years an active lumberman, and fifty of these spent in Canada, is in short the life history of Hon. J. K. Ward, of Montreal. Born in the Isle of Man in the year 1819, he was at an early age apprenticed to the trade of carpenter and joiner. Having completed his tenure of apprenticeship,



he decided, when twenty-one years of age, to emigrate to the United States, and after being employed in different pursuits for three years he secured a position as second clerk in a saw mill at Troy, N. Y., later leasing the mill and operating it on his own account. In 1853 he decided to prospect in Canada, and bought a saw mill and property on the Maskinonge river, in the province of Quebec, where he spent ten years lumbering, adding during these years somewhat to his possessions. Ten years later he moved to Three Rivers and acquired the limits and mills built and owned by Norcross, Philips & Company. This property he operated successfully for several years and sold to advantage to an American company.

Encouraged by previous efforts, Mr. Ward obtained a large area of timber land from the Quebec Government, situate on the Rouge River, a tributary of the Ottawa, and established a large saw mill at the Lachine canal. This he operated from 1870 to 1900, when he transferred the business to a company in which his eldest son is largely interested. The annual cut of this mill has been about 15,000,000 feet. Mr. Ward has shipped largely to England, the United States, South America and the West Indies. As an instance of the proportions of his business, it may be stated that in 1886 he shipped 116 cargoes of lumber, in vessels varying from 100 to 1,000 tons burthen, to English and foreign markets.

Mr. Ward has always been a strong advo-

cate of preserving the forest and is the author of many interesting papers on Canadian woods. Addressing the Natural History Society in Montreal on April 29, 1895, he said: "While not an alarmist as to our supply of pine timber, I cannot but consider the wanton waste of it a sin. A mistake is made by our millmen in not having more sawing capacity than the fast mills now in use possess, sawing as they do in twelve hours 40,000 to 50,000 feet with one circular saw. Too much haste is required to do this, when more money might be got out of the same logs by employing two sets of saws, with the necessary trimming machinery, and doing the work with less speed."

In 1888 Mr. Ward was named a Legislative Councillor by the late Mr. Mercier, Premier of Quebec, probably the first case recorded where a practical mechanic, a man who had sprung directly from the working classes, has held this exalted position. He is now in his eighty-sixth year and resides at Westmount, a suburb of Montreal.

ROBERT STEWART.

Robert Stewart, of Guelph, Ont., spent his early years on the home farm in the Scotch Block, Township of Esquesing, Halton county. At the age of seventeen he went to Toronto, where he acquired a thorough knowledge of the building trade and lumber business. He relates that he saw lumber brought into Toronto and sold for \$4.50 per thousand feet; joisting 3x12x24 sold for \$5. In his early days a railway was unknown from a practical standpoint, all lumber being teamed in from



the surrounding townships, and, as a natural consequence, the contrast between then and now is very marked.

Mr. Stewart relates an incident of some sixty odd years ago. A friend of his, a millwright by trade, was travelling through the country when he came across a man running a water mill with a gate saw. Mr. Stewart's friend asked the owner what he would give

him if he would double the capacity of his mill. The owner replied that he did not know what he would do with the lumber if he cut double the quantity he was now cutting.

In 1855 Mr. Stewart removed to Guelph, Ont., and laid the foundation of his present extensive business. He has one of the largest planing mills and sash and door factories in Western Ontario, and in addition handles several million feet of lumber each year.

Mr. Stewart is probably the oldest lumber dealer in Ontario and the oldest active business man in Guelph; in fact, he still looks after every detail of his business, especially in the manufacturing department.

J. R. BOOTH.

Mention of early lumbering operations at once suggests the name of J. R. Booth, of Ottawa. Not only is he a pioneer in the lumber business, but he stands prominent to-day



as the timber king of Canada, a distinction which he has won by indomitable perseverance and ambition.

Mr. Booth was born in Waterloo, Que., on April 5, 1827, and lived on a farm until he reached manhood. As a boy his mind ran to mechanical devices and he decided to become a millwright. His first lumber work was in assisting to build Leamy's saw mill at Leamy's Lake, about fifty years ago. He then removed to Ottawa and leased a small mill. This was burned down after being operated only a few months. He rented another mill immediately and added two shingle machines. His first encouragement came in the shape of a contract for furnishing lumber for the Parliament Buildings. He worked out his contract at a substantial profit and purchased the saw mill after three years' occupancy.

Borrowing money from the bank, for which he paid 7 per cent. interest, Mr. Booth purchased a large limit at a low price and increased the capacity of his mill by putting in two gang saws. Realizing that timber was likely to

greatly increase in value, he added to his timber holdings as rapidly as possible, which proved to be a very wise policy. To-day he owns about 4,250 square miles of limits—sufficient timber land to make a strip a mile wide reaching across Canada from the Atlantic to the Pacific.

Mr. Booth's saw milling business steadily expanded, until in 1892 he had thirteen band saws and four gates in operation, with a capacity of more than one million feet in ten hours. In May, 1894, his extensive mill was destroyed by fire. Shortly afterwards he purchased the old Perley & Pattee mill adjoining the burned property and fitted it up with improved machinery. The plant as it stands to-day will cut from six to eight hundred thousand feet of lumber in twenty hours.

Although in his seventy-eighth year, Mr. Booth still enjoys good health and is able to give personal attention to his important interests.

ISAAC COCKBURN.

Few lumbermen of the present day have a wider knowledge of the early methods of lumbering than Mr. Isaac Cockburn, of Winnipeg. In his boyhood days his father was extensively and prominently engaged in the



timber trade on the tributaries of the Ottawa river, where the subject of this sketch became familiar with the business. At the age of twenty-two he undertook a venture in purchasing some timber and a short time thereafter embarked generally into the manufacture and transportation of timber for the Quebec and European markets. Being young, active and energetic, he devoted all his available time to an oversight of the proper manufacture and quality of the product. As a result, it was only a few years before he had established a reputation among the Quebec merchants for the superior quality and manufacture of his timber, so much so that some large firms of timber merchants, when purchasing timber under contract for subsequent manufacture and delivery, would stipulate that the quality be equal to that of Cockburn's manufacture, this being the only provision as to the grade.

In 1870 Mr. Cockburn extended his lumber-

ing operations to the states of Michigan and Wisconsin in the manufacture of waney pine, hewn and sawn oak, oak staves, rock elm timber and pine deals for export to Quebec and the European markets. To facilitate the transportation of the timber he, in conjunction with two others, established the Collins Bay Rafting and Forwarding Company, which has met with much success under the able management of Mr. Leslie, of Kingston. He at the same time became joint owner of three vessels which were employed in carrying forward his timber products from Lakes Huron and Superior to the foot of the lakes, to be then taken down the St. Lawrence river to Quebec for further shipment by vessel. About the same time he established a saw milling business on the Humber river and subsequently in the Muskoka district at Gravenhurst.

Removing to Manitoba in 1891, Mr. Cockburn directed his attention to the fuel problem of the western country, and realizing the importance of it acquired some coal lands, formed a joint stock company and entered into mining. This venture was a success and the company are now developing a large output. His present interests in the lumber business are in the Dauphin district of Manitoba, but he is also secretary-treasurer of the Western Retail Lumbermen's Association.

ROBERT LAIDLAW.

Born in the Township of Esquesing, Halton County, which township acquired its name from the Indian language, and meaning "tall pines," Mr. Robert Laidlaw became a lumberman almost from his infancy. Although living on a farm until about thirty years of age, he at the same time was interested in lumbering. In the year 1871 he formed a partnership with the late Thomas Shortreed, under the firm



name of Shortreed & Laidlaw, and moved to the town of Barrie, in the County of Simcoe, where they purchased a block of timber. They operated several mills and continued to lumber in that neighborhood until practically all the timber was cut out.

Mr. Laidlaw removed from Barrie to Toronto in 1886, establishing a wholesale and retail lumber business, and later opening branch

offices and yards at Sarnia, Ont., and Buffalo, New York. He is also interested with Mr. A. McPherson, of Longford Mills, and in the R. T. Jones Lumber Company, of Tonawanda. Notwithstanding the vast extent and scope of his operations as a lumber dealer, he has continued to maintain his timber interests in the north.

The concerns with which Mr. Laidlaw is associated, and particularly the R. Laidlaw Lumber Company, are a very influential factor in the lumber trade. This is very clearly demonstrated by the fact that the turn-over of the two above mentioned companies last year was ninety million feet, of which sixty-eight million feet represented the business of the R. Laidlaw Lumber Company.

From the beginning Mr. Laidlaw may be said to have been eminently successful in business, first obtaining the necessary practical experience, then applying it to good advantage in his later and more extensive operations. He is held in very high esteem by the lumber fraternity.

NATHANIEL DYMENT.

Nathaniel Dymont, of Barrie, Ont., has attained marked success in the lumber world, which can be attributed largely to his energy



and perseverance. His early operations were in the townships of Ancaster and Beverley fifty years ago, when he was but a youth of seventeen. His first transaction involved one pine tree, which he purchased for a dollar. This dollar he earned by cutting two cords of wood. In Ancaster and Beverley there were originally rich pine forests, and Mr. Dymont soon established a large business and built several other mills on the line of the Great Western Railway.

About twenty-five years ago Mr. Dymont extended his operations into Simcoe County and the North Shore and built larger mills, the organization of the present great lumber firm of Mickle, Dymont & Son being effected in the year 1886. Mills are now operated at Gravenhurst, Severn Bridge and Thessalon, the yearly output being upwards of 35,000,000 feet.

Mr. Dymont is conceded to be an authority

on the lumber trade, knowing the business thoroughly from the woods to the counting room. In his younger days as a salesman of lumber there were few his equal. He is a close observer of life, events and business methods, and although quiet and unassuming, has a most interesting individuality.

H. H. COOK.

Mr. H. H. Cook is a member of a well-known lumber family, being the only survivor of five brothers who were actively engaged in lumbering operations. He is a son of the late George Cook, who lumbered for many years on the St. Lawrence and Ottawa rivers and was one of the first persons to take timber to Quebec. The subject of this sketch commenced to lumber with his brothers when eighteen years of age, taking out square tim-



ber on the Trent waters. Turning his attention to saw logs, he built his first mill at Midland, Ont., in 1872, when that town comprised but two shanties. The mill contained two gangs and two double circulars, and cost upwards of \$100,000. Mr. Cook has built seven different mills, the last one being at French River in 1882. This plant has since been remodelled and is now one of the most complete saw-milling establishments in Canada, being equipped with the latest labor-saving appliances. He owns a large area of timber limits on the French river and tributaries and the Vermillion river, his operations being conducted under the name of the Ontario Lumber Company, with head office in Toronto.

H. L. LOVERING.

Mr. H. L. Lovering, of Coldwater, Ont., was born in England in 1835, and came to Canada in 1842, settling in the Township of Medonte, County of Simcoe, which was then almost a wilderness. He commenced lumbering in October, 1850, at the mouth of the Severn River, now known as Port Severn. The mill was owned at that time by the late Jas. Sanson, jr., H. B. Robinson being associated with him in the operations. The capacity of the mill was about one thousand feet in twelve hours, and Mr. Lovering's salary was five dol-

lars per month. He remained there for two years, then went to Lake Superior, cutting the first board of lumber that was manufactured at the head of Lake Superior where Superior and Duluth now stand. In 1857 he returned to Ontario, and became associated with A. R. Christie, of Port Severn. Since 1870 he has been connected with the Georgian Bay Lum-



ber Company. He has seen the growth of the lumber trade on the Georgian Bay from less than one-half million feet in 1850 to several hundred millions.

HON. PETER WHITE.

Hon. Peter White commenced to lumber in October, 1858, in conjunction with his brother, the late A. T. White, the firm name being A. & P. White. This partnership continued to exist until the death of the senior partner in 1900, since which time the business has been car-



ried on by the subject of this sketch under the original name. Mr. White's father was one of the first lumber operators in the Ottawa Valley, coming to Canada from Edinburgh, Scotland, and founding the town of Pembroke in 1828.

When A. & P. White embarked in the lum-

ber trade the principal product was squared red and white pine, of which, as is generally known, large quantities were sent down the Ottawa river and also the Trent waters. The making of saw logs in large quantities did not commence on the Ottawa until about 1870. For some years the firm of A. & P. White have been engaged in the manufacture of sawn lumber, their mills being located at Pembroke and having a capacity of about 6,000,000 feet per annum. Mr. White is also a director of the Pembroke Lumber Company.

Mr. White is a strong advocate of the protection of the forests from fires. He has seen large areas on the Ottawa destroyed during the last fifty years, and believes that if fires had been kept out and the timber judiciously cut, the supply on the Ottawa river and its tributaries would have been practically inexhaustible. As an instance of the advantage of watching the fires closely, he points out that the limit owned by the late Wm. Mackey, on the Amable-du-Fond, which he purchased in 1861 for a few hundred dollars, was sold in 1900 for \$655,000, and after square timber had been cut on it for thirty years.

Mr. White has devoted much time and attention to public affairs, having represented North Renfrew in the Dominion Parliament almost continuously from 1874 to 1896.

NICHOLAS FLOOD.

One of the oldest living operators in the timber and deal trade of the Province of Quebec is Mr. Nicholas Flood, a resident of the Ancient



Capital, whose identification with this trade in the successive capacities of culler and manufacturer extend over a period of more than half a century.

Mr. Flood was born in the County of Wexford, Ireland, and came to Canada when but eight years of age. A year later, at the tender age of nine, he began his service as a culler's assistant in Walker's Cove, Quebec. Since that time his has been an unusually active career, covering as it does the most prosperous period of the Quebec export timber trade. For many years Mr. Flood received for the owners at Cape Rouge Cove from seven to thirteen

millions of board pine each season. Cape Rouge Cove was then one of the most prosperous of the Quebec timber coves and was indeed a hive of industry. The late James Bowen was manager of this property, with Mr. Flood as his assistant. Subsequently the late Mr. Amos Bowen succeeded to the management, and upon his death, about twelve years ago, Mr. Flood was appointed to the office of manager of the Cape Rouge Wharf & Pier Company, which office he still holds.

As a manufacturer of various kinds of square timber Mr. Flood has established himself in a very successful manner. His operations have been more or less extensive and have been confined to the Province of Quebec. He is still as actively engaged in trade as at any former time in his career. There is no operator more popularly known than he, and certainly none more highly esteemed for his industry, integrity and general worthiness as a citizen of the city of Quebec.

WILLIAM LITTLE.

Although now retired from active lumbering operations, a record of Canadian lumbering would be incomplete without some reference to Mr. William Little, formerly of Caledonia, on the Grand River, County of Haldimand, but now residing at Westmount Heights, Montreal. In the early sixties he carried on extensive operations on the Grand River and the Lake Erie shore, especially dealing in the large square pine and mast trade with New York, Quebec and England. From these districts he supplied for many years the Quebec con-



tractors with the Admiralty with the bulk of the large white pine masts required by the British navy, and also the Quebec timber trade with rafts of square pine averaging 150 cubic feet per stick as compared with the present averages of less than 50 cubic feet. Of late years Mr. Little has devoted most of his time and energies rather to the subject of the propagation and preservation of our forests than to their destruction. The deep interest taken by him in this direction is evidenced by his election as honorary president of the Canadian Forestry Association.

Mr. Little's knowledge of the existing con-

ditions of the forests of Canada and the United States, as relating to the lumber industry, is probably unsurpassed by anyone in either country, as it may be said he has made this subject a life study, having grown up to a practical knowledge of the trade in the business of his father, the late James Little, who was one of the pioneer lumbermen of Upper Canada, having begun operations in Caledonia in 1834, where William was born in 1836, his father becoming one of the most extensive manufacturers of pine lumber for export from the Grand River district, having at one time ten saw mills in operation and being the first to ship Canadian pine lumber in quantity to Albany, Buffalo, Cleveland and Toledo.

Mr. Little has frequently contributed articles to the CANADA LUMBERMAN on forestry subjects, especially protesting against the suicidal policy (now happily abandoned by Ontario) of allowing the free export of saw logs and pulpwood to the United States, while that government exacts duties on Canadian lumber and pulp. His intimate knowledge of the timber trade relations between the countries enabled him to render valuable assistance to the advocates of free lumber at Washington in controverting the misrepresentations made by the United States manufacturers, which resulted in the adoption by Congress of the free lumber clauses in the Wilson tariff bill.

C. M. BOSTWICK.

Mr. C. M. Bostwick is a gentleman who, for a great many years, has been closely identified with the lumber industry in the Maritime Provinces. His first venture was in the shape of large mills and lumber properties at Point Wolfe, N. B. After operating this plant for some years with great success, he disposed of it and purchased the Great Salmon River and Martin's Head properties from the Estate of the late Wm. Davidson. These properties are situated at the mouth of the Great Salmon River on the Bay of Fundy shore and about forty miles from St. John. Although they were, at the time of the purchase, very valuable, Mr. Bostwick, with characteristic energy, set himself to add to their value. He increased his holdings until they had become the most valuable lumber properties held by one person in the Maritime Provinces.

The place where the mill stands is perhaps the best site in the Maritime Provinces for a water mill. The power is abundant and is never inadequate. Mr. Bostwick's aim was to make the mill in every way equal to a steam mill, and by means of extensive remodelling and the addition of the most modern improvements in machinery, he fully attained his object.

Mr. Bostwick's limits lay along the Great Salmon River and its branches. The logs were driven a distance of from two to thirty miles. The manufactured article, which consisted of deals and lath, was nearly all shipped to St. John by means of a fleet of schooners and scows owned by his company, to be loaded on steamers bound for Great Britain.

The village near the mill took its name from the river. The cottages were all owned by the company and the inhabitants were all

employees of the company. Mr. Bostwick took a great interest in the welfare of the villagers. He provided a church for all denominations, a school for which he employed a competent teacher, and made it a point to use his influence to have both well attended.

The head office of the company was at St. John and was connected by telephone with the mill.

Mr. Bostwick had many splendid offers for this valuable property, but had never entertained any until last summer, when he opened negotiations with the Pejepscot Paper Com-



pany, of Brunswick, Me., which resulted in the sale of the lands, mill, stores, warehouses, schooners, scows and all utensils and facilities. The transfer was made on September 21st last. The new company is called the Bay Shore Lumber Company. Had Mr. Bostwick been a younger man it is probable that he would have been the controller of this huge industry for many years to come, but having been actively engaged in business for fifty years, he has decided to retire.

REORGANIZATION OF A CANADIAN LUMBER FIRM.

The business of Price Bros. & Company, Quebec, has been converted into a limited stock company, capitalized at \$3,000,000. The new company will bear the title of Price Bros. & Company, Limited, and will take over upwards of 6,000 square miles of timber land, with eleven saw mills and other property in the way of wharves, etc. The saw mills are located at Batiscan, St. Louis, Rimouski, Matane, Cape St. Ignace, St. Rosarie, Metabetchouan, Trois Taumons, St. Anne and Amqui, all in the province of Quebec.

The negotiations in connection with the formation of the new company were conducted by I. H. Benn, of the timber importing firm of Price & Pierce, London, England, which has also been intimately associated with Price Bros. & Company. The deal includes a bond issue of about \$1,000,000, but as a basis for the exact amount of the issue, James D. Lacey & Company, of New Orleans, are about to make an examination of the property and an estimate of the timber thereon.

HISTORY AND DEVELOPMENT OF THE LUMBER INDUSTRY OF BRITISH COLUMBIA



The progress of the lumber industry in British Columbia, from the time of the erection of the first mill until the present, when considerably over 100 plants are in operation without taking into account sash and door factories, box factories and other co-operative institutions, can be noted, since the beginning of the development of this province dates back only forty years. In fact, less than twenty years covers the period, or since the completion of the construction of the first Canadian trans-continental highway. At no time, however, has the industry attained a greater growth than during the last five years, consequent upon the marvellous number of immigrants taking up land in the Northwest Territories and the beneficial legislation of the Provincial Government. As a result, about fifty mills have sprung into existence in the interior of the province, mostly in the eastern portion, where there is a considerable area of timbered land, and from where the territorial markets are within comparatively easy reach. The effect was also noticeable on the coast, and in Vancouver city a large number of mills was built. There have been periods of depression, every province and every industry being similarly affected at times, but through it all the manufacturing of lumber has gradually increased. The future is very promising. The timber in British Columbia for size, quality and quantity has no equal, and now that the eastern forests are being depleted, the successful millmen are establishing themselves in this province, where the manufacture of lumber will continue when in other parts of the world it will have become a thing of the past.

Since the early history of the lumber industry in British Columbia has never been written it might be recorded with interest for the first time. Perhaps the first mill erected was that by the father of Mr. J. A. Sayward, now conducting the same business at Victoria. Following the discovery of gold in the Cariboo, and the settlement of Victoria in the latter fifties, the elder Sayward, who had been conducting a lumber business in San Francisco, came north to the new colony, and built a mill at a point called Mill Bay, in the Shawnigan district on Vancouver island. This was operated by water power, and twenty-six years ago the plant was moved to the city of Victoria, when steam power was installed, and it has been run on the same site ever since. English capital established a mill at Alberni in the early sixties, with Capt. Stamp as manager. The product was for export, there being no local market. This mill was in operation for a few years, but not proving a financial success it was closed and the plant sold.

The first mill on the mainland was that erected at Moodyville by Messrs. Moody, Dietz & Nelson. The place, directly opposite Vancouver on the north shore of Burrard inlet, was named after Mr. Moody, who was drowned in the memorable disaster to the steamer Pacific in 1875. Mr. Nelson afterward became

lieutenant-governor of the province. This mill was operated continuously until a couple of years ago, when it was purchased by the B. C. Mills, Timber & Trading Company. In 1865-66 the Hastings mill was built on the site it at present occupies, on the south side of Burrard inlet, by an English company. Capt. Stamp, who had operated the mill at Alberni, was the first manager, being succeeded by Capt. Raymond, who was followed by Mr. R. H. Alexander, the present manager.

There are two points of extreme interest in connection with the establishment of the Hastings mill, as it is still known. The machinery, office and other supplies comprised a full cargo of the ship Kent, when bushels of pens and lead pencils by the hundred gross were sent out, with sufficient stationery to last for twenty years or more. Two four-pounders were also included, intended for the protection of the property in the Indian wars. These cannon were never used, and are still to be seen at the mill. Even yet there is some of the cannister shot, a large amount of which was the cargo, and which was to scatter English death among the screeching ranks of tomakawking Siwash.

The other interesting incident was the selection of the first site. In those days, when no cities nor towns were in existence on the Pacific coast of Canada, and Indian villages were the only settlements, all land looked alike to the venturesome trader. A site was cleared in the reservation now known as Stanley Park, at the spot where the recreation grounds are now located. The first mill was to have been built there, the wharves to be in the bight of the Narrows, through which entrance is made into Vancouver harbor. The current was found to be too strong, and a move was made further up the inlet to the next jutting point, thus preserving in its entirety that peninsula of land which afterwards became Stanley Park, the finest of its kind in the world.

In those days primitive methods were employed, logs being taken out of the woods by bullock teams and towed by hand. Of the early steamers used in towing, two might be mentioned. These were the Grappler, a condemned gunboat, which was burned in the north, and the Beaver, the first steamboat to ply on the Pacific, having rounded the Horn in 1836. The latter ship, while going out after a boom in the summer of 1888, piled her historic bones on the rocks at the entrance to Vancouver harbor. For twenty years the mills logged the territory where Vancouver city is now located. Some of the pioneers are still here, notably Mr. Jonathan Miller, postmaster.

Associated with the early history of the industry were John Hendry, David McNair, A. Haslam, W. J. Armstrong, Mr. Carpenter, R. H. Alexander, C. M. Beecher and R. B. Kelly. The mill at Moodyville was burned shortly after its construction, and in 1874 Mr. Hendry came over from Washington state and assisted in its rebuilding, remaining for some time, having charge of the operations at night.

In the winter of 1875 he erected a mill at Nanaimo for Mr. Carpenter, and in 1876 one for W. J. Armstrong at New Westminster. With David McNair he started a sash and door factory in Nanaimo, and in 1877 Messrs. Hendry, McNair, Haslam and Kelly built a small saw mill, sash and door factory and box factory at New Westminster, which afterwards became the Royal City Planing Mills Company. At present it is owned by the B. C. Mills, Timber and Trading Company.

These were the earliest establishments. In 1885 the Royal City Planing Mills Company purchased the mill at Nanaimo, which after a year was taken over by Messrs. Haslam and A. E. Lees, who gave their share in the business in New Westminster for it. Mr. Haslam is still operating it, Mr. Lees having a clothing and gents' furnishing business in Vancouver. The mill was destroyed by fire this year, but has been rebuilt.

With the extension of the Canadian Pacific Railway to Coal harbor, and the beginning of Vancouver, the lumber industry was, naturally, the first to develop. In 1888 the Hastings mill was purchased by the Royal City Planing Mills Company of New Westminster, of which Mr. Hendry was head. Mr. Alexander, who first became connected with the Hastings mill in 1870 as storekeeper, and succeeded in 1881 to the managership, became interested, as did also Mr. Beecher in the new company of the B. C. Mills, Timber & Trading Company, which was incorporated in 1889. In the early nineties more mills were built, and many of the large establishments doing business in Vancouver to-day were started about that time.

On Vancouver Island a mill had been built at Cowichan, near Victoria, by Messrs. Hewitt & McIntyre, who failed. Sayward's were operating in Victoria, and in 1894 American capitalists established a mill at Chemainus, under the firm name of the Victoria Lumber and Manufacturing Company. Mr. E. J. Palmer is the manager. This mill is one of the largest on the coast, and with the Hastings mill does an export business which is not exceeded by any of the large mills in Washington state. In New Westminster, Ross & McLaren, Ottawa valley people, erected a large establishment. It remained idle because of depression until about a year ago, when it was taken over by Whatcom and San Francisco capitalists. De Beck's, afterwards the Brunette mills, was among the first, and also that built by J. G. Scott, who enlisted Ontario capital. The latter shipped the first red cedar shingles to Ontario in 1892, a trade which has increased very considerably.

The development of the industry was steady but not very rapid until 1901. The effects of immigration first began to be felt, and immediately following the enforcement in 1902 of the order-in-council prohibiting the export of logs, mills were erected with exceeding rapidity. In Vancouver, the older establishments ex-

panded, and numerous new ones were built. Principal of the latter was that of the Pacific Coast Lumber Company, on Burrard inlet, near Stanley Park. When his mill in New Westminster was destroyed in 1901, Mr. J. G. Scott, with his brother and Messrs. McCormick, Campbell, W. Irwin, D. Irwin and others of Ontario, erected this plant in Vancouver. Then, too, it was that mill after mill sprung up in East Kootenay, and at present some very large mills are projected. Mills were built by Otis Staples, of Stillwater, Minn., near Cranbrook; by the Elk Lumber and Manufacturing Company, Minnesota people, at Fernie; by the Big Bend Lumber Company at Arrowhead, in which the Ludgate brothers of Seattle are the moving spirits; by the Arrowhead Lumber Company, of which Mr. W. R. Beatty, formerly of Ontario, is manager; by the Crow's Nest Pass Company at Wardner. These are some of the largest, there being many others. J. P. McGoldrick, G. A. Lammers, with other Minnesota associates, contemplate the erection of a mill near Nelson; the Mundy Lumber Company, of Bradford, Pa., will build near Revelstoke; and the Kamloops Lumber Company, of which Mr. George McCormick is president, is rebuilding the mill at Kamloops destroyed by fire in September.

To-day the lumber industry is larger than any other in Vancouver. Some of the more prominent of the manufactories besides the Pacific Coast Lumber Company's plant and that of the B. C. Mills, Timber & Trading Company already mentioned, are those of E. H. Heaps & Company, Robertson & Hackett, Rat Portage Lumber Company, the Hastings Shingle Manufacturing Company (which also has several mills in the state of Washington), Thos. Kirkpatrick, the Canada Lumber Company, Woods & Spicer (now controlled by J. G. Woods), the Urquhart Mills, and others.

A feature of the last two years is the large number of operators coming into the province from Ontario, Minnesota and Wisconsin. Not only are they interested in the manufacture of lumber and the holding of large tracts of timber, but in the establishment of pulp mills, no less than five of the latter being proposed, principally backed by American capital. One of the most promising industries in store for this province is the manufacture of wood pulp, and following the recent beneficial legislation enacted by the local government, companies are now actively engaged in the preliminary work of extensive enterprises. When it is considered that the Douglas fir, as well as spruce, is a good pulp tree, the possibilities of the industry in a province where the Douglas fir is the dominant and most widely distributed conifer, are obvious. A paper mill was started and ran for some time at Alberni, but under conditions not favorable to success. An important factor bearing upon the future of British Columbia as the centre of the pulp and paper trade of the Pacific is the depletion of the forests of the United States.

The mildness of the winters, admitting of operations being carried on throughout the whole year, is a point in favor of the lumber industry in this province. Atmospheric con-

ditions are especially favorable to tree growth, which is very rapid, and the extent of otherwise valueless country along the coast that can be devoted to forestry is enormous. A feature of the timber areas is their density, the yield being greatly in excess of that obtainable in eastern Canada. This density enables logging to be carried on to greater advantage.

R. B.

IMPROVEMENTS IN SAW MILL MACHINERY.

By C. H. WATEROUS, Brantford, Ont.

It will be found upon consideration that the past twenty-five years have not seen any very great or very radical changes in the machinery for the actual cutting or manufacture of lumber. Probably the perfecting of the band saw during that time has been productive of the most good, as, with its development into a thoroughly practical machine, it is possible to produce lumber of an equal quality, in as great a quantity in a given time, and with a very great saving in what formerly used to go into saw-dust, a loss that accompanies all operations of sawing lumber.

As timber became scarcer, and got farther back into the country, making the getting out of logs more costly, this waste became more and more emphasized, and the desire, in fact the need, to minimize it was of such importance that all progressive lumbermen were anxious to experiment with any improvement that looked feasible and practical. The band mill, therefore, that had been for many years struggling for a place, came into prominence and received the attention, at the hands of both manufacturers and users of this class of machinery, that was needed to make it a success, with the result that it is fast displacing both the old-time circular and gang for lumber cutting. The band mill will cut about as fast as either the gang or the circular, with the great advantage that it takes probably less than half the saw kerf of the average circular, and equal advantage may be taken of the log; it takes less saw kerf than the average gang, while with the latter no advantage can be taken of the log as it is being cut, to get the best that is in the log, out of it. When the amount of lumber produced each year in this country is considered, the saving made by the use of the band mill is a very great annual addition to the wealth of the country.

The changes in mill design, much heavier and better built machinery, and the addition of labor saving appliances, have been very great; in consequence, lumber is cut more cheaply and much truer to size. In the latter case particularly this is a great gain, as when lumber is being worked up into its finished state the loss is much less if the stock is true to size.

Steam and power operated machinery for handling both the logs, lumber and refuse has displaced manual labor in most of the operations in the larger and better class of mills. To watch the progress of a log through a mill is most interesting. The steam kicker now throws the logs on to the log deck, where formerly a man laboriously performed this operation; the sawyer by means of a steam log roller now rolls the logs on to the log carriage

as he requires them; with the steam nigger the log is turned on the carriage, the steam or power setter sets the logs up to the saw, steam feed handles the carriage back and forth, during its cutting, at a rate of speed completely under the control of the sawyer; live rolls carry the product of the logs away from the saw, power transfers and power driven chains transfer the product to the edger, trimmers and slashers, and carries it out of the mill to the point where it is assorted and finally disposed of.

This statement does not convey to anyone not familiar with the operation of a saw mill anything like an adequate idea of what an important part these labor saving devices take in a mill, and in the carrying on of the great lumber industry. It means a revolution in the handling of logs and the production of lumber, and means that a vast amount of thought by first-class mechanics, and large sums of money have been expended in arriving at the present perfection of modern saw mill machinery. Most interesting and very ingenious devices for the saving of raw material, and of labor, the two great desiderata of all modern manufacturing industries, are seen in modern saw mills in probably as great perfection, and in as much variety, as in any other industry. These changes have come so gradual that their importance upon the great lumber industry of the country is apt to be overlooked.

If it were possible to place side by side one of the old time water mills of say forty years ago, with its up and down saw, of which it was humorously said "went up to-day and down to-morrow," and compare the quantity and quality of its output with one of the mills of to-day, the vast improvements that have been made in saw mill machinery would convey very forcibly the fact that in this field of improvement changes have taken place almost as great as in that of transportation, or the other large industries. As population and the demands for greater comfort and more luxury in our homes grew, the demand for lumber increased, so that it was but natural for man to give more thought to its production, and the steadily diminishing forests made it necessary to strive by invention to reduce its waste.

Whether as great changes will be made in the next twenty years as in the past is, of course, a question that cannot be answered to-day, but it does not look as though this would be the case. Greater care in the sawing of lumber, and a lessening ambition to produce the greatest possible quantity, without regard to quality or waste, will probably give manufacturers a better quality with a lessened waste. This means that necessarily the ways that now prevail in the older countries will be more nearly followed, where the chief thought is not given to the greatest possible output, but to the greatest possible saving of timber. The saws and much of the machinery as used to-day will probably continue, with improvements, for many years.

The third annual meeting of the Hardwood Manufacturers' Association of the United States will be held at Nashville, Tenn., January 24th and 25th. Mr. Lewis Doster, of Columbus, Ohio, is secretary of the Association.

SAW MILL EQUIPMENT OF THE EARLIER DAYS

By WM. COOKE, Hillsdale, Ont.



WM. COOKE.

THE history of saw mill machinery proves that the earlier methods of manufacturing lumber were very crude as compared with the modern saw mill of the present day. My memory takes me back fifty years, and I will first give you a description

of a mill in England as I remember it at that time. The machinery consisted of the following: A small circular saw large enough to rip 6x8, with a plain flat table, and a large circular saw which was used for sawing Quebec square timber. The carriage for this saw was simply a table like our old-fashioned single edger table, the saw running between two planks coupled together, while the feed was a

or improvement. The price of sawing in England was five shillings per 100 feet for hardwood, or twelve dollars per thousand feet board measure. It will be readily understood that the sawing process was a very slow one.

The first circular saw was made, I think, between fifty and sixty years ago. The man who conceived the idea made a pattern of the saw and took it to the saw works to have one made. The saw makers looked at him and asked him if he were crazy. They laid his pattern to one side and put him off by promises. Month after month went by, until the man at last insisted upon the saw being made, the success of which all lumbermen know.

I remember that about forty years ago a circular saw was used for cutting veneer in Bristol. The saw was very thin, made in sections and screwed on large cast-iron collars, made the same as our shingle saw collars. This saw was twelve feet in diameter and was used in two stories of the mill.

Coming to our mills in Canada, say forty-seven years ago. Most of the mills then con-

Within a few years the muley? saw was replaced by the circular saw, which was responsible for a great improvement in the speed of making lumber. The operation of these mills involved much hard labor, all the sidings having to be packed up and carried to the edger and the balance of the stock carried to the end of the mill and stood on end, then placed on a wagon and taken to the pile.

About the first improvement to lighten the hardest work in the mill, namely, tail sawing, was a wooden roller with a wooden gudgeon and set in a frame. By this means the tail sawyer could run his boards and planks out instead of carrying them. This was improved upon by wooden rollers and iron gudgeons, and later on by what is known as live rollers, and what was the hardest work in the mill forty years ago is almost the easiest now.

The next improvement in mill equipment was a log canter, or what we call an overhead canter, usually driven by a belt from a saw mandrel and consisting of a roller with a worm gear. On this roller was attached a chain, with a hook on the other end, and which went around the log; as the roller turned the log turned also, thus doing away with a lot of heavy lifting. After a few years this canter



AN OLD-FASHIONED MILL—SHOWING GUIDE BLOCKS.

From Bulletin No. 34, Bureau of Forestry, U.S. Department of Agriculture.

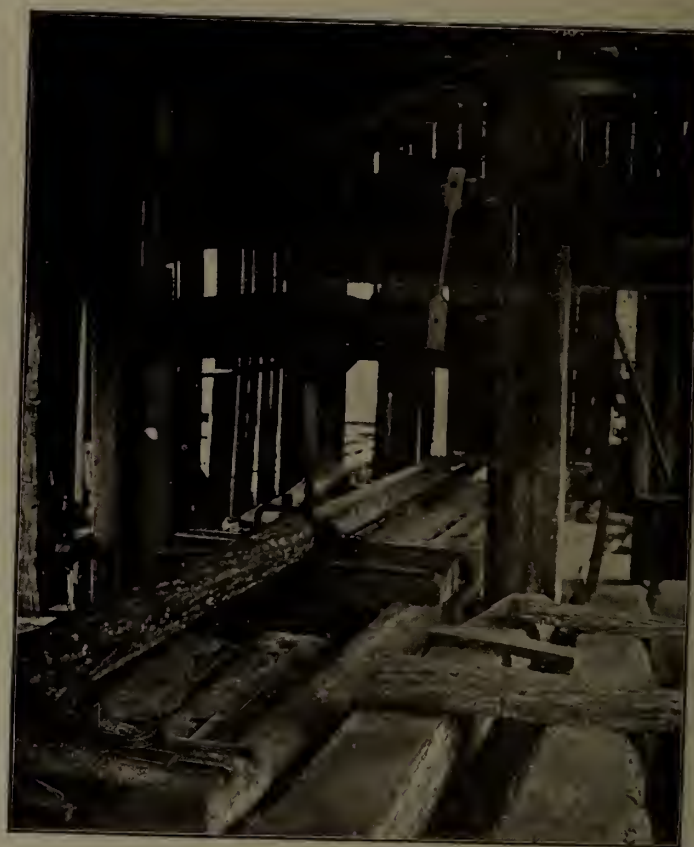

MILL BUILT IN 1853—SHOWING SAW GATE.

rack and pinion. The rack was fastened to the table and the pinion was turned with a crank by hand. The saw guides, as we call them, were a casting for holding a roll of hemp, and as the saw required changing the one side was pressed harder than the other against the saws. There was a gate, or gang it may be called, with saws of sufficient number and thinness to take eleven boards out of a 3-inch deal. The writer saw this mill eight years ago and the same machinery that was there fifty years ago was still standing and running in the same place without any change

sisted of a muley saw rig or a gate and a single upright saw, usually run by water power and operated by one man, who hauled up his logs, spotted them for the carriage, set his log for the cut and put his saw to work, then, leaving his saw running, went to dinner and when he came back found the saw still cutting. There were no edgers in those days, the sidings being used rough edge, and they can yet be seen in the sheetings of some old buildings with the stubshot on. In those days the price of lumber was from four to six dollars per thousand, and everything was nearly clear.

was discarded for a canter of greater speed, which we call a nigger (rather a peculiar name for a machine, but he is a fine fellow in a mill). The first canter of this kind was installed in our Canadian mills about thirty-three years ago and was driven by friction. This canter was used in Michigan before that time. It has since been much improved and is now driven by an upright steam cylinder.

Gang saws were installed in several large mills thirty or thirty-five years ago and have since played an important part in the manufacture of lumber. The next great change was from the circular to the band saw.

CANADA IN RELATION TO THE WORLD'S FUTURE TIMBER SUPPLY

By E. STEWART, Dominion Superintendent of Forestry.

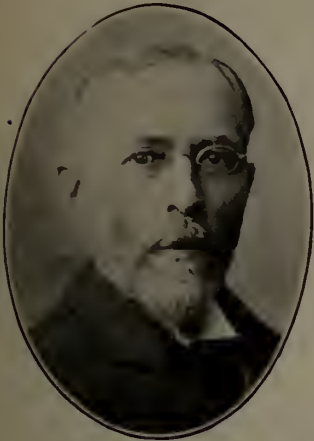

E. STEWART.

THE free gifts of Nature are seldom appreciated or even considered so long as the supply is sufficient for the demand, and in no case is this more apparent than with respect to the virgin forest which to this country at least deserves to rank foremost among the many natural resources we possess. We cannot conceive of a more beneficent gift than

is exhibited by one of these large white pine forests of the older provinces, or of the giant Douglas firs and cedars of British Columbia. They represent great wealth where man has contributed nothing whatever to produce it.

For ages after the last glacial visitation had passed away Nature was active in restocking the denuded land, so that when the transatlantic invaders landed on our eastern shores about four centuries ago they found the whole country bordering on the Atlantic and extending for about a thousand miles inland one vast forest. This wilderness contained in great abundance a larger variety of woods valuable for economic purposes than could be found in any other part of the world of the same extent. Beyond this forest belt for another thousand miles stretched the treeless plains of the interior, corresponding to the pampas of South America and reaching to the foot hills of the Rocky Mountains.

It was, of course, impossible, as well as undesirable that this forest should be allowed to interfere with the cultivation of the land for the growth of agricultural products; and as there was no market for the timber for a long period during which the clearing process was going on, and it was desirable to rid the land of the timber as quickly as possible, fire was used for that purpose.

Had the respective positions of the wooded land and of the prairies been reversed, and the early settlers had the prairies to deal with instead of the woods, the result would probably have been that very little valuable timber would have been consumed by fire in the log heap, for by the time settlement would have reached the timber land, in this reversed position, the market afforded by the settlers to the east would have given value to the forest product. But it is not for us to question the wisdom of Providence, and perhaps a little consideration will show that if the condition had been reversed in the way supposed the result would have been more serious and detrimental to the pioneer and would have caused him greater inconvenience even than he had to encounter under existing conditions. If the land along the west coast of the Atlantic where settlement began had been prairie instead of woodland we can easily fancy the hardships that would have confronted the pioneer when he landed on the bleak shores of the ocean over which he had sailed, with no timber on hand to supply material for his new home, for fuel, for fencing his land, and for a thousand other uses to which wood is applied by the backwoods settler. Instead of having this great staple right at hand he would have been compelled to bring it with him across the sea, an operation in those days so expensive as to render it impracticable. As it was, he used what timber he required for his own purposes and burnt up the rest, and this went on for years and centuries till to-day in one belt in the United States, extending from the eastern seaboard right across to the prairie, the work of the axe has been so ruthless that the line between the prairie and the once forest wilderness is indistinguishable, and the settler of the

one district is just as dependent as that of the other on outside sources for his supply, and what is true in this respect of our neighbors across the line holds good with the settlers in the older parts of Canada. Each has now to go far afield for his timber supply.

The inhabitants of the eastern states when their home supply became scarce or exhausted invaded Michigan, Wisconsin, Minnesota and the Canadian provinces on the north and the southern states on the south, and now as the supply from certain of these sources is giving out, while from others the cost is greatly increasing, they are turning their eyes to the Pacific Coast states as a last resort, and the question of a future timber supply for the United States, which country until yesterday was looked upon as a field upon which the older nations could depend, is now engaging the serious attention of the far-seeing citizen of that country.

A few figures from our trade returns will show how rapidly the importation of wood into the United States from Canada is increasing. The value of our exports of home produce of wood and manufactures thereof to the United States was:

During the fiscal year ending June 30, 1898	\$ 9,840,524
During the fiscal year ending June 30, 1899	10,511,019
During the fiscal year ending June 30, 1900	14,087,088
During the fiscal year ending June 30, 1901	13,176,717
During the fiscal year ending June 30, 1902	16,682,183
During the fiscal year ending June 30, 1903	18,823,878

This shows an increase in 1903 over that of 1898 of \$8,983,354, even surpassing our export for the same period to Great Britain by \$30,001; and this in the face of the American duty. This certainly indicates the great market for wood material that the United States alone will afford us in the future.

Space will not permit of a review of our exports to all the other countries of the world which receive more or less from us. Suffice to notice that our total exports under this head in 1903 amounted to \$40,742,641, being an increase over the previous year of \$5,567,167.

Taking a review also of the forestal conditions of the older European countries and of those of South America and the Orient, and the great home market now being created by the rapid settlement of the prairie country, and the only conclusion that can be drawn is that the future demands for all classes of wood material will be so great as to tax severely all the sources of supply, and that as a consequence prices, though they may waver, will show a gradual if not rapid advance. Notwithstanding the increased use of brick, iron, stone and concrete in structural works, the consumption of timber goes on increasing faster than it ever did before. Such being the case, any country possessing an available supply will assuredly have an abundant market.

The question then for us to answer is, "Has Canada such a supply?"

If this question had to be answered in the negative it would be as much deplored by those countries that are in constant need of a supply and which are holding out their hands to us for it, as it would be by ourselves.

Though we have lost vast quantities of timber by fire, still Canada undoubtedly stands at the head of those countries from which a future supply may be expected. It is true that our virgin white pine cannot last very many years longer, but we have other varieties of great value. In British Columbia we have the Douglas fir, the cedar, the western white pine, and a hemlock very much superior to our eastern hemlock, but above all we have the spruce, the most widely distributed of all our forest trees. If we visit the mills of the Maritime Provinces we find them cutting that timber for export to Europe, and so fast is its natural reproduction in the moist

climate of the coast that the same territory can in the ordinary way of lumbering be recut about every twenty years. Starting west from the Atlantic in Nova Scotia we find the white and black spruce in all the older provinces and in all the districts of our Northwest Territories, while in the interior of British Columbia another variety, the Englemann spruce, a very useful tree, is found in great abundance, and west of this and extending to the coast, the giant of this species is found in the Menzies or Sitka spruce which almost rivals in size and utility the giant Douglas firs of the same district.

Not only is the range of the different varieties of the spruce bounded only by the Atlantic and Pacific on the east and west, but it also extends over more degrees of latitude than any other of our native trees, reaching practically across the whole country from its southern boundary up to the limit of tree growth, in some places extending beyond the Arctic circle. It must not be inferred that the whole of this vast area is covered with merchantable timber, but on the other hand there can be no question that this country possesses an immense quantity of spruce timber which probably no other country can equal. A very large portion of it is growing on land which, from its rough character and also from its severe climate, is unsuited for the growth of agricultural products and should be kept permanently for the production of timber. In other words, it should be Canada's wood lot.

In addition to the utility of spruce for lumber it is of all varieties the one best adapted for pulp, an article which is now being applied to such a variety of purposes that the demand for pulpwood is enormously increasing every year, and there seems little question that this industry is only in its infancy and that our northern forest regions with the unlimited water power they possess will in the not distant future be the home of important and lasting industries.

The eyes of the European nations are turned to Canada for their future supply of timber. Are their expectations to be realized or disappointed?

This question can only be answered on certain conditions. If we fail to realize that we possess vast wealth in our wooded wilderness and take no means, first, to preserve the virgin growth, and second, to frame our policy so that growth and reproduction may go on indefinitely, we will not only disappoint less favored countries in this respect, but also prevent the realization of the hopes of our own people who have a right to demand the preservation of a really great heritage.

We must not forget that we possess in those unhabited wilds more than the merchantable timber now existing there. We too often overlook the potentialities of the forest and forget that great life forces are constantly at work by which reproduction and growth are maintained so that the sapling of to-day will be the timber tree of to-morrow, and it in turn will cast its seed on the soil for another crop in the still more distant future. Mr. J. R. Booth a year or two ago ventured the prediction that if correct forestry methods were adopted in the pine regions of Canada our grandchildren would have a larger quantity of that variety of timber than we possess to-day. This opinion is probably correct.

Taking Canada as a whole, there is no doubt whatever that she possesses a first place among the timber producing countries of the world, and it is to be hoped that this position in the future may not only be maintained but relatively advanced.

W. M. Drader is rebuilding his cooperage stock mill at Chatham, Ont.

The Maple Leaf Flour Mills Company, recently incorporated at Ottawa, with a capital of \$1,000,000, are given permission to carry on the business of flour milling, lumbering, mining, etc. D. C. Cameron, manager of the Rat Portage Lumber Company, is one of the charter members.

SAW MILLING OF THE PAST AND PRESENT

By J. B. BENSON, Midland, Ont.

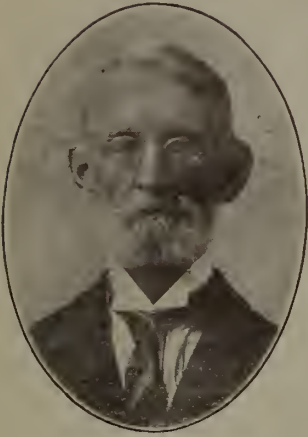

J. B. BENSON.

SAW milling, like everything else, has advanced with wonderful strides since fifty or sixty years ago; in fact, its growth has not been surpassed by any manufacturing industry, and few have equalled it.

Fifty years ago the mills were all driven by water power and were located throughout the country wherever a stream could be found having

sufficient water to drive a small mill containing one upright saw, which did all the work, cutting the boards as well as edging them. One man could run the whole mill and take away and pile the lumber cut. The sawyer had time to take a smoke while the saw was working its way slowly through a log. The refuse was disposed of by being thrown into the stream to the great detriment of the fishing, no fishery inspector being around then to prevent the act. One yoke of oxen would supply a mill with logs as fast as they could be cut, and the logs would be hauled from the stump at that.

Remains of ancient saw mill equipment can be found to this day scattered along the different streams emptying into Lake Ontario and the St. Lawrence river.

Farmers often constructed mills to provide themselves and their neighbors with necessary lumber for building purposes, lath, shingles and other products as now obtained from the refuse being then unknown. Lumber was sealed by the use of a tape line. No foreign market of much account existed except for deals, which were generally rafted on top of a timber bottom and floated to Quebec. Everything was in a primitive state at that time as compared with saw milling of a few years later. The capital invested was confined to a few hundred dollars in each mill. Men were paid to keep the mills from being covered up by the slabs and debris accumulating about the premises, they throwing it into the stream or burning it.

The next step in advance was when the circular saw came into use, some ten or twelve years after the above mentioned dates. This was a great stride in advance and produced great changes in the trade. Then began an era in the business which opened up the export lumber trade until it soon became of much importance. Men of large capital engaged in the manufacture of lumber and steam mills were built. This soon did away with the small water power mills. Lath, shingles, etc., began to be made. The change effected by the introduction of the circular driven by steam may probably be noted as the greatest and most progressive step ever taken in the history of the manufacture of lumber.

Mills twenty-five years ago were confined to circulars and gates. The circular, as compared with the gate, was wasteful, but did its work in a fair manner. The gate, although not equal to the band of to-day, produced remarkably good lumber, uniform in thickness and commanding a higher price than that produced by the circular. It also effected a great saving over the circular, producing less sawdust by reason of its smaller saw kerf—a saving of probably ten per cent.

The gate, although good in many ways, had its drawbacks, among which might be mentioned the difficulty of putting large logs through, these having often to be cut down by the axe, which caused a considerable loss of good lumber. Double or top circulars lessened this evil to a considerable extent,

but few mills had them, and they were very liable to make a break or cause an uneven surface in the lumber so produced. This was something which lumber inspectors quickly recognized and often severely condemned under inspection. Until about twelve years ago circulars and slabbing and stock gates prevailed in all the best mills and produced a good description of lumber, but as before mentioned at a great sacrifice of timber and also inability to separate the best part of the log from the cull or poorer part as well as to divide a log into its most desirable thicknesses. The circular, of course, obviated this difficulty where it was used; but just here a weakness occurred when the log was not properly placed on the carriage. In a large percentage of

mill. Through its use the greatest output from the log is obtained, while it has the advantage over the gate of enabling the sawyer to cut to such thicknesses as are most desirable and also to grade at the saw to a certain extent. When this mill first came into general use in this country, it was sometimes weak in respect to uniformity of thickness, but to-day that difficulty has been overcome, even the double cutting band doing its work most efficiently and producing a description of lumber that is the pride of the inspectors—both as to uniformity of thickness and smoothness of surface.

The management and operation of a saw mill of to-day, or I might say a modern saw mill, is something which no novice need attempt unless he courts failure. Saw milling (particularly the management of a large mill) has become a trade or profession requiring a thorough apprenticeship and experience in order to be successful. The operations are of a very varied nature, and we find associated with the



AN OLD OVERSHOT WATER WHEEL.

From Bulletin No. 34, Bureau of Forestry, U. S. Department of Agriculture.

logs there is a good and a bad side, and in the desire of most operators of large mills to produce quantity, quality was sacrificed. It is a question if small mills had not an advantage in this respect over the larger mills. The small mill man not being so rushed, took pains to properly place his log so as to obtain the greatest quantity of the best grades of lumber from it. He may have lost in time a board or two in quantity, but more than made it up in the value of lumber so obtained.

To-day the mill having the call and being generally recognized as superior to all others is the band

management of mills men of skill and education. The old days have passed and the lumberman of to-day is as far in advance of his predecessor of half a century ago as is the railway train ahead of the old stage coach. Business tact and experience of the highest order are necessary to success. Millions of capital has been invested in lumbering operations, and as a contributory to the financial resources of Ontario the lumberman stands most prominent.

The operations of a saw mill of to-day begin, as formerly, at the log. Men of skill are employed to sort, boom and crowd up to the jack-ladder such

logs as are immediately required in the mill to fill its present saw bill. The jacker, or man at the foot of the jack-ladder, floats his logs on to the chain, which is endless, and carries the log into the mill, in number equal to the mill's capacity, say from one to two thousand pieces per day. Upon their arrival in the mill they are immediately transferred from the chain automatically to the several log ways intended for them. Here again they are turned on to the carriages by appliances which do away with the old-time manual labor of twenty-five years ago; in fact, heavy manual labor is now reduced to a minimum. Clever mechanical appliances do the work of the mill in almost every instance where a few years ago this was only effected at a great expenditure of sweat and muscle.

The sawyer on a steam feed double band mill now takes charge of the log. He must be a man of experience, active and quick witted, otherwise things might come to grief. Upon this man depends to a great extent the amount of work done each day by the saw. He is also expected to guard against accidents to his saw. His helpers on the carriage must be men of quickness of decision and much ability. The distance they travel during the day, through the gigging back and forth of the car, represent a great many miles of speedy travel. As fast as the boards drop from the saw they are carried by line rollers to the edger if they require edging. The boards, already square edged, pass on to the trimmers. The edger is one of the most important men in the mill. He has it in his power, through neglect, carelessness or incompetence, to waste or throw away his wages many times in a day. It is therefore extremely necessary that he be a first-class man at his work. There is no edger too good or well qualified for his business.

The boards next show up at the trimmers, without a board having to be carried by the men. Formerly the lumber was taken from the saw in armfuls by men and deposited at the edger and trimmers. This was extremely hard work and so slow in performance as to be impossible now without a force of men sufficient to nearly wipe out the value of the output. At the trimmers the lumber is carried through the trimming saws, which cut off the defective ends and reduce it to the lengths best suited to bring each board to its greatest value. This work is truly an expert's business. He makes grades, and, in fact, does what might be termed a mill culling of everything passing from the mill. Considerable depends on him, and none but most capable men should be here employed. When to reduce in length, and when not to do so, so as to represent the greatest value in a board are qualifications not easy to find in a man on the trimmer.

From the trimmers the boards are passed in various ways to cars, each grade or mark being loaded by itself, the cars, when loaded, going to the pilers. Not much skill is required in the work of car loading, quickness and muscle being the chief qualifications.

Taking the lumber from the mill is part of the work requiring great attention. It is seldom that two mills are alike in this respect, various plans having been adopted lately, and each having some merit. As compared with the systems in use twenty years ago, the output of a mill nowadays is handled at far less cost. Four men will now do the work of twice the number formerly employed. Chain carriers, in some mills, carry the lumber and drop each kind to the car intended to receive it, simply by the manipulation of a lever in the hands of the man in charge. At other mills a system has been adopted whereby the board is run off the chain carriers by large wooden rollers and shot on to its proper car. Others again have different plans to accomplish the same result, the object of all being to do the work with the least expenditure of manual labor. A decision as to which system is the best can only be determined by proving which will do its work at the least expense per thousand.

Piling the lumber is important work. A good piler is a man of experience. To build a pile in a good workmanlike manner requires skill, and a proper

observance of certain rules. It is absolutely necessary to have your lumber dry and in good shape so that it will come out at shipment in first-class condition. In shipping lumber competent scalers and tally boys are necessary. A scaler should be able to decide at a glance the contents and quality of the boards as fast as a number of men can shove them from the pile to car or vessel. Good scalers of great expertness are necessary at a modern mill.

An up-to-date mill can now be fired by sawdust almost alone, whereas formerly great quantities of slabs had to be provided to fuel with. The sawdust is carried direct from the saws and dumped into the fires.

The refuse of the logs is now being carefully husbanded. Lath, barrel heading, box shooks, staves and shingles are produced from what formerly went to waste, while slabs not suitable for the before mentioned products are carefully piled and shipped. Even sawdust is quite frequently shipped to the cities for different purposes, and at some mills the smallest and roughest of the refuse is used in the manufacture of wood alcohol.

Re-sawing machines are largely in use to cut rough lumber and slabs into marketable shape.

Fire appliances of all descriptions find a place in and about a modern mill, with often a drilled fire company of the employees. Fire insurance represents a large outlay in the cost of management of a mill.

Every day a careful count of the number of logs sawn should be handed in to the office, and the yardman return an estimate of each day's quantity of lumber sawn. Piles should be numbered and a plan of the yard kept in the office, by means of which the office man or manager can in a short time determine the location, quality and quantity of everything in the yard. The office staff of a large mill should comprise a number of capable accountants, time-keeper, message boy, typewriter, etc., and everything should be kept in a most thorough and systematic manner.

There is no busier man in any business than the manager of a large saw mill. He is on deck at 7 a.m., and can always be found from then until 6 p.m.

The saw mill of to-day is generally considered to be near perfection, but a few years hence will, no doubt, show great improvements on the present system. In this advancing age no one can afford to stand still, we must all keep on the move, and the saw mill man is bound to keep pace with the times.

DOMINION GOVERNMENT TIMBER.

In his report upon the forestry work in Canada, Mr. E. S. Stewart, Superintendent of Forestry, says:

It will be seen from the census of 1901, that an estimate is made of the area of forests and woodlands for each of the provinces and also for the Territories. That of Manitoba and the Territories is placed at 722,578 square miles. Add to this 20,000 square miles of Dominion territory in the railway belt in British Columbia, and we have 742,578 square miles as the total on Dominion lands. Probably about one-fifth of this contains merchantable timber, or say 150,000 square miles, or 96,000,000 acres. After thus reducing the area, and remembering that in addition to the timber suitable for lumber, a large part of it is covered with spruce valuable for pulpwood, it can scarcely be considered an extravagant estimate to place the merchantable timber, including pulpwood, at 2,000 feet board measure per acre, or in all 192,000,000,000 feet. We have thus arrived at a very rough approximation of the quantity of timber now fit for use on the lands owned and controlled by the Dominion.

At the lowest, the value of such timber standing in the tree may be put at \$1 per thousand feet board measure, that would amount to \$192,000,000. This represents only what might be collected by the Government as a royalty, and forms but a small part of its value to the country as a whole. Much of the timber is growing on land unsuitable for agriculture, but where water power is abundant, and with the power thus at hand this country should be without a rival in the manufacture of all articles in which timber forms the chief ingredient.

It may be said that a very large percentage of this timber is not at present available, and that consequently its value is overestimated, but when we consider the great appreciation in the value of timber limits within the last ten or twenty years, and the scarcity of the world's supply for the future, it is almost certain that the enhanced value that will be obtained in the future for what is now inaccessible will more than pay compound interest on the present estimated value.

The above estimate takes no account of the younger growth. In considering the potentialities of our forest areas, their capability of affording a continuous crop should be kept clearly in view. Even under the discouraging conditions prevailing in our lumber regions after logging operations have ceased, it will be found in most cases that another crop, either of the original or other varieties, is fast springing up, and in my calculation of the value of a timbered territory, which is to remain permanently in forest, this growing crop should be taken into account.

Without going too minutely into this phase of the subject, I am of the opinion that if we confine our cutting of saw logs to all trees above 12 inches at the butt and pulpwood to say 7 inches, the annual increment of growth fit for use will be not less than 140 feet board measure to the acre, or an annual growth increment equaling 13,440,000,000 feet, which at the above rate of \$1 per thousand stumpage, would give a perpetual annual return equal to \$13,440,000.

THE WHITE PINE OF WISCONSIN.

The State of Wisconsin will, according to the Mississippi Valley Lumberman, be the next to give up the last of its white pine. The pine forests of Michigan have been consumed and their lumber product has ceased to be an important factor in the general market. The annual output from that state is now below a billion feet. Wisconsin mills still continue to manufacture about two billion feet of lumber annually. Every year more mills are added to the silent list and the towns which have grown up about them are assuming new roles in their industrial character. In our investigations to secure information upon the probable extent of the standing white pine in the northwest, we have compiled the following data for Wisconsin. In 1897 the Department of Agriculture of the United States Government made a calculation of the white pine timber then standing in Wisconsin. This was based upon the estimates furnished by lumbermen. The research was made as thoroughly as possible and conducted among the smaller producers as well as the larger manufacturers. From these estimates the standing timber in Wisconsin at the beginning of 1897 was placed at eighteen billion feet. The reports of the different mills which draw their log supply from Wisconsin timber show that there has been cut since that time 13,643,669,200 feet. Taking this amount from the eighteen billion feet standing in 1897 will leave the present amount of standing timber at only 4,356,330,800 feet. A general survey of Wisconsin forests and of the reported holdings by the different owners of stumpage in that state makes these figures seem correct. If the mills continue to saw white pine as vigorously as in the past, Wisconsin will cease to be a white pine lumber producer within the next three years. The state, however, is still rich in its hardwood and hemlock resources. The character of lumbering operations will undoubtedly undergo a change within the next year. Many of the mills which draw their entire log supply from white pine timber will go out of commission, others will reduce their cut and draw upon their holdings of other timber. It is therefore probable that less white pine will be cut in Wisconsin next year, and the remaining supply of timber will hold out longer than would be the case if the present output was continued.

A man who don't advertise is like a person trying to find a dollar in a dark room without a light.

L. Dillenger has acquired about 6,000 acres of timber land in the vicinity of Kitchener, B.C., and purposes incorporating a company to commence active operations by the erection of a saw mill at that place.

ONTARIO'S FOREST RESERVES

By THOS. SOUTHWORTH, Director of Forestry.



THOS. SOUTHWORTH.

THE Province of Ontario is one of the greatest business corporations in the world. Whether viewed in the light of an inheritor having a vast estate to dispose of, or as all this and a trading company as well, Ontario is an extensive corporation doing business in a very large way.

Its shareholders are the individual people of the province, and handsome

dividends are yearly paid to them in the form of the support of public services, charity and education, that would otherwise be paid for out of their private pockets in the form of taxes.

I presume it may be stated that the working capital of the province is, through the right to levy taxes, only limited by the ability of the citizens to pay, as is the case with other similar corporations having more and richer shareholders, but it is proposed to refer only to the estate or inheritance common to us all in our land and water areas, and what they contain or produce. This includes land, forests, minerals, game, fish and water powers, all of which supply an income that could be increased if desired.

Unlike many corporations or trading companies, however, the Province realizes that there are ways in which the "greatest good to the greatest number" of the shareholders in this enterprise may be reached other than in the direct payment of cash dividends, and it has been deemed for the general good that the forest should be worked as the chief producer of cash dividends.

Therefore for the purpose of this article we will eliminate any consideration of any of the Provincial assets other than that of the Crown Forest.

The forest wealth of the Province has until recently been classed under two divisions; that still remaining the property of the Crown partly sold under license to lumbermen, and partly without any claim at all; and that part held by settlers to whom lands had been allotted or sold by the Crown.

THE LUMBERMEN AND FARMER.

In the development of the timber trade in Ontario the idea gradually evolved was to dispose of the merchantable timber, principally pine, for cash revenue, before handing over the land on which it grew to individuals to be converted into farms. Having this idea in view, the business was not regarded as one of our permanent industries. The lumberman was considered as but the forerunner of the farmer, and no attempt was made for many years to do any more than harvest the standing crop of pine and other coniferous trees to the best advantage. No idea of taking off another crop than the original one was thought of. For many years this process worked well. As lumbermen established camps, and cut over their limits, the shantyman often became a farmer, squatting upon a tract of good land as he found it in the limit, and he was soon followed by his friends. This process has settled many townships in the Province, and where the land included in the limit was good for farming, no better plan could probably be devised. The hardwoods and enough pine for building purposes were left on the land for the settler, and from the money received from the largest pine, roads were built for the settler and the whole people of the Province shared in the dividends.

As the lumberman pushed farther north in search of pine, however, the character of the country changed. Large areas were placed under license to

lumbermen in which the land was unsuited for farming. The settler still followed the lumberman and tried to make farms where nature had provided that forests only could be profitably grown, finding out only after their capital and the best years of their lives had been spent, that they had made a mistake.

While these men have been wasting their efforts dragging out a bare existence, the Province has lost large sums in cash that might have been derived from these same areas had they been left to produce a second crop of pine timber.

In addition to the encroachments of settlers upon the forest area, fire proved a prominent factor in emphasizing the ephemeral character of the lumber industry; large tracts were burned over, until it began to be recognized as the natural thing that fire followed the lumberman. The success of the fire ranging system adopted in 1885 showed that this danger could be largely removed.

REFORESTATION.

This partial immunity from forest fires led our legislators to consider the possibility of giving the forest industries a more permanent character, and in 1895 when I was appointed to the forestry work under the Government, I was directed by the then Commissioner of Crown Lands, the Hon. A. S. Hardy, to submit a report on the best method of reforesting these burned areas with pine; to ascertain the comparative cost of planting and of sowing tree seeds, with plan of operation.

Estimates of the cost of seedling trees for replanting were secured, and in the process of investigating the burned over areas to ascertain the probable cost of getting them in condition to replant or sow, I concluded and so reported that neither was necessary except in a few places. The cost of replanting or even of seeding successfully would be so great per acre that the directors of the corporation, the Legislature, would never vote the money necessary to accomplish the work over so large an area and they would be right, for it is very likely that the initial expense compounded even at three per cent. for the number of years necessary for the plantation to reach a merchantable age, plus the annual expenditure for protection and care, would exceed the amount realized from the crop even at the enhanced prices likely to be obtained at that time.

TREE PLANTING UNNECESSARY.

It may be said that even so, for the sake of the incidental or indirect benefits in the way of climatic effect and water supply the investment would be worth while, but it was found that planting was not at all necessary, that practically all the investment required was time and freedom from settlement or fire. On burned over territory a new forest was growing, and in nearly every case, where pine was present in the previous crop, pine was growing again, not at first perhaps; the first crop after the fire was usually birch, poplar or other trees that seed yearly and whose seeds carry immense distances, but nearly always pine followed where the fire had left any parent pine trees within a wide radius, and would be found growing up under the shade and protection of the broad leaved trees, under the exact conditions required to make good timber.

This condition of affairs simplified the problem of reforestation in Ontario Crown lands, and in my report to the Government in 1896 I recommended that areas found unsuited for general farming should be permanently withdrawn from settlement and placed in Forest Reserves.

In the following year the Government appointed a Royal Commission to report on the same subject. This Commission included among its members two of the ablest lumbermen in Canada, the late E. W. Rathbun and the late John Bertram, and this Commission endorsed this recommendation as follows:

"A large portion of the Central Division of the

Province is more profitable from the standpoint of public revenue as forest land than under cultivation for farm crops, and as in addition to this it contains the headwaters of all our principal streams, all that part of this Division found upon examination to be not well adapted for farming should be added to the Permanent Crown Forest Reserves."

In 1898 the Legislature passed an Act entitled "An Act to Establish Forest Reserves," the first specific action by legislation towards the creation of a permanent Crown Forest. This Act was submitted to the Legislature by Hon. J. M. Gibson, then Commissioner of Crown Lands, and was passed without a dissenting voice.

PRESENT RESERVES.

The passage of the Forest Reserves Act, and the creation of Reserves thereunder, is the formal announcement of the Government policy of gradually separating the non-agricultural from the agricultural lands, and is the first organized and definite attempt to create a permanent Forest Estate to be owned in perpetuity by the Crown and operated for timber crops. Under the Act there have so far been created four Forest Reserves, amounting in all to 5,821,000 acres. These include the Eastern Forest Reserve of 80,000 acres; the Sibley Forest Reserve of 45,000 acres; the Temagami Forest Reserve of 3,776,000 acres; and the Mississaga Reserve of 1,920,000 acres.

There should be added to this Algonquin Park created in 1893 mainly as a Game Preserve, with an acreage of 1,101,000 acres, making a total of Permanent Forest Reserves of 6,922,000 acres.

These Reserves are of different character. The two former, the Eastern Reserve in Frontenac County and the Sibley Reserve, which takes in the township of Sibley including Thunder Cape on the north shore of Lake Superior, have been lumbered, and in most cases burned over, and now contain a very thrifty growth of white pine and other trees. It will be some time before they are ready again for lumbering operations, but the growth is very rapid and the time when they may be again operated for pine and other timbers much less than would be imagined in the absence of definite information and measurements of the rate of growth of this young timber.

The Temagami Reserve lies in the District of Nipissing and contains 5,900 square miles or 3,776,000 acres. This Reserve besides including some of the most picturesque and beautiful lakes in the world, of which Temagami and Lady Evelyn might be mentioned, contains a very large quantity of pine timber now ready to be cut. About forty years ago the band of Indians living in the territory, alarmed at the incursions of the lumbermen who were operating on Lake Temiskaming and at the suggestion, it is said, of a Hudson's Bay officer equally interested with them in the preservation of this country as a hunting ground, started a fire that swept over a good many hundreds of square miles, including the northern part of Temagami, Lady Evelyn, Anima, Nipissing and other lakes. Over this burned territory there is now a thrifty growth of poplar, birch, as well as pine and other coniferous trees, the pine making growth at the rate of one inch in diameter in about two and a half to three years. Of the timber now sufficiently large to cut or what would be estimated by a lumberman in buying the territory for lumbering, I believe there is about five thousand millions, or five billions of feet B. M., exclusive of spruce, tamarac and hardwoods.

The Mississaga Reserve is included in the territory drained by the Winnebago and Mississaga rivers in the District of Algoma, and lies between the main line of the C. P. R. and the Sault Ste. Marie branch of the same line. It comprises a territory of 3,000 square miles, or 1,920,000 acres, and is estimated to contain over three thousand millions of feet of merchantable white pine besides other timbers.

In giving these figures of areas of Forest Reserves, it must be borne in mind that the Government has only recently entered upon this policy, and it requires time to properly investigate the different areas before having them come under the provisions of the Forest Reserves Act. By the Act a Reserve can be created by Order-in-Council, but if on further inves-

tigation it was found desirable to open this land for agricultural purposes, a subsequent Act of the Legislature would be necessary in order to take it out of the Reserves. In a general way, however, we are aware that there is a very large territory in the Province of Ontario peculiarly suitable for permanent forests.

PERMANENT FOREST AREA.

So far as the question of future timber supplies and the consequent effect on climate and industrial conditions are concerned the Province of Ontario is in a peculiarly fortunate condition. The southern part of the Province which extends almost into the middle of the United States is a very rich agricultural section, now entirely settled up, and the home of a prosperous agricultural community. North of this agricultural belt, stretching across the Province from east to west, lies the watershed separating the streams flowing south into the Great Lakes and the St. Lawrence from those flowing north into our great Canadian sea. This height of land or watershed is not a mountainous ridge, but a more or less level tableland, rugged and rough in character, for the most part quite unsuited for agriculture, but the natural home of the white and red pine, spruce and other coniferous trees. True, in this belt there are occasional valleys of good land. In the Temiskaming district for instance, there are nearly a million acres of rich alluvial clay soil. There is also a good agricultural section in the Rainy River valley and another one at Wabigoon on the main line of the C. P. R. But generally speaking, that is the character of this immense watershed stretching hundreds of miles across the Province from east to west.

North of this territory again, on the slope running to Hudson's Bay, lies another agricultural district, estimated to contain over sixteen millions of acres of first-class farming land, but covered at present with a very valuable growth of spruce and other timber.

In estimating the annual dividends possible or likely to be derived from this forest asset, a good many things have to be taken into account. While the Reserves so far created are pine bearing, not all of the territory suitable for reserves contain pine at present though they may be made to do so. Some of this territory is rocky and has been so severely burned over, notably on the north shore of Lake Superior, as to have no soil left, and we need to figure on long periods of time before those small areas will become productive. There must also be eliminated the water areas, and fire must be counted on as a contingency.

The present Forest Reserve area includes distinctly pine bearing lands, and for purposes of computation over the whole area, I will take this area 6,922,000 acres as a basis. In a country where we have no large artificial plantations that have reached maturity from the seed, it is difficult to form definite conclusions as to the annual growth of timber, but from measurements obtained by the Washington Bureau of Forestry over many parts of the northern or pine-bearing states, they have adopted nearly sixty cubic feet as the normal annual growth under ordinary forest conditions on an acre of forest land. This includes the whole of all sorts of trees, not pine alone. This in board measure would be 720 feet per acre per year. In our pine-bearing land, particularly in the Reserves referred to, white pine is not the only tree, but it is the dominant tree, and a large proportion of this annual growth will be of that variety of timber.

Pinchot and Graves in their exhaustive study of the white pine in Pennsylvania, estimate that a pine tree 10 inches in diameter will yield 84 per cent. of merchantable timber, and in a tree 26 inches diameter only 7 per cent. is waste. Under continuous operations, 10 per cent. would be a fair allowance for waste in all kinds of timber, but there should also be eliminated much solid timber not now merchantable. With allowance also for water areas and spots not well seeded, I do not think 300 feet B.M. per acre an unreasonable estimate for the annual growth of pine on an acre of land in the areas. That it is not unreasonable is shown from yields on lands that have been cut over. There are numerous in-

stances where 50,000 feet of pine per acre have been cut, and this where only the merchantable trees were removed, leaving many others on the way to a merchantable size, while our estimate is for the total annual growth.

An ordinary forest well seeded to pine would produce this 50,000 feet in about 100 years or at the rate of 500 feet per year. One other deduction must be made, however, for fire, for while we have greatly lessened the damage from this source, it must be counted on, and we will reduce this estimate 50 per cent. or 150 feet B.M. per acre per year for the pine timber only. This estimate applied to our present reserves would give an annual production of 1,038,300,000 feet.

As to the value of this timber, much depends on its location and ease of access to market. On the basis of the recent timber sale, \$7 per thousand feet would be a fair average as applied to the Reserves in question. This would return annually \$7,268,100. This sum appears large, but it must be borne in mind that the territory now being operated each year, probably not so large as this, returns \$1,000,000 to the Treasury, and at \$1.25 instead of \$7 per thousand feet.

It would perhaps be unfair to apply the prices realized at the recent sale to the whole of this area, but to reduce it to \$5, a very modest estimate, the annual increment in pine would reach a value of \$5,191,500, and besides the other timbers growing on the Reserves, spruce, cedar, birch, larch, maple, etc., have a commercial value that is rapidly increasing.

One hundred and fifty thousand feet B.M. at \$5 per M. would be worth 75 cents as the annual rental value of this land. It may at first sight appear high, but the Prussian Crown Forests under a most expensive semi-military system of management, including the cost of maintaining several Forestry Schools and Colleges, yield a net income over all expenses of about \$1.45 per acre per year over the whole territory good and bad. I am well aware of the difference in conditions as to markets, etc., but surely if the Germans can obtain a net revenue of \$1.45, we can, in time at least, under proper management, realize half that sum as our gross revenue. I might also add that the Crown Forests of Saxony yield about \$4.50 per acre per year, net.

A recent concrete instance of the growth of pine under somewhat adverse circumstances is shown by the result of a small plantation of pine trees on the sand plains of Nebraska. This plantation covers .52 of an acre on the ranch of Bruner Bros. in Moit County, Nebraska. It is rectangular in form, measuring 70 x 192 feet, and is located in sand hills bordering a dry valley. The trees on this plantation were set out in the spring of 1891 as three year old seedlings averaging about eight inches in height. Furrows were turned two feet apart, and the trees were planted two feet apart in the furrows. Since planting the trees have received no cultivation whatever, but they have been protected from fire and stock. The altitude of the location is 2,200 feet.

This sand is what is ordinarily called blow sand and covered some of the small seedlings. Last year the Bureau of Forestry at Washington had these trees counted and measured, when it was found that the total volume of wood in the plantation was 586.02 cubic feet, with a total annual growth of 50.6 cubic feet. This, converted into board measure, would be over 600 feet per year on a fraction over half an acre, or 1,200 feet per acre per year.

It is true these trees were planted at regular intervals, and would therefore have a better chance for growth than trees reproduced by nature with her wasteful methods, but it must also be remembered that the soil was very bad and of such a nature as had been considered hitherto quite incapable of growing trees at all.

Hence it will be seen that my estimate of 150 feet B.M. per acre per year in our peculiar pine bearing country is a very moderate estimate. Applying this estimate to say 40,000,000 acres of Permanent Reserves, which I hope to live to see, we have a yearly growth of 6,000,000,000 feet, which at \$5 per M. would represent a value of \$30,000,000.

This is not a rosy picture, but a very conservative

estimate, and if the timber other than pine is considered, it will be found low.

MANAGEMENT OF FOREST RESERVES.

And now having definitely adopted the policy of separating agricultural from non-agricultural lands, placing large areas of non-agricultural lands in Reserves to form a permanent Crown Forest to be operated in perpetuity for timber supplies and the payment of cash dividends, the problem is presented of how to work these Reserves to the best advantage.

In this various problems present themselves. The first, of course, is the great one of fire protection, but this I am happy to say we are within reasonable distance of having solved. Of course in the forest, as in the city, the prevention of fires entirely is an impossibility, and in the forest there is the added difficulty not often found in well regulated cities, that a fire once under headway cannot be checked by any human agency at present known. At the same time the system of patrol adopted some years ago is proving very effective, and our losses from fires for the past few years have been inconsiderable.

Among the most serious problems confronting the Government in the permanent timber policy, is the reproduction of the right kind of species from a commercial point of view. This Province is the habitat of probably the most valuable timber tree in the world, the Weymouth or White Pine, the tree that has been so great a factor in the prosperity of the Province. There are peculiar features connected with its reproduction that have to be carefully considered in any permanent forestry operations.

In the first place, I have noticed that where a forest has been operated for pine for a number of years, and where no fire has taken place, there seems to be no seedling pines coming up. True, there are pine trees still growing to take the place of the mature trees removed, but they are trees that were suppressed and stunted in their growth at the time of the previous lumbering operations, and that took on new growth after the pressure in the forest was relieved, but I cannot find that in a forest of this sort there is any new crop coming on, that is to say, trees that have seeded since the cutting of the original crop.

Why this is so is not quite clear to me, but I imagine the reason will be found in the fact that the ground and the conditions of shade are not suitable for the proper germination and growth of the pine seeds.

On the other hand, where there has been a forest fire, after lumbering operations, we nearly always find a growth of young pine coming up, at any rate if any old or seed trees have been left in the vicinity of the fire.

Assuming this condition of affairs to be general, that young pine will not come up as a second crop except under suitable conditions, it will readily be seen that if in operating an old forest, nothing but the pine trees are taken out, the result must eventually be that the character of the forest will have changed from a pine forest to one of another description, and necessarily of a less valuable character. If it is pine mixed with spruce, if the pine is removed and the spruce only allowed to reproduce, it will naturally become a spruce forest, or a hardwood forest as the case may be.

Hence it is obvious that in operating an old or virgin forest with a view of reproduction of the most valuable sorts of trees, a scientific knowledge of the growth and method of reproduction of these trees will be necessary in order to have the cutting properly executed. This must be done also with a view to the financial part of the operation, because whether in private forestry or Government forestry, it must necessarily be largely a commercial proposition, and the cost of operating must be considered in its relation to the ultimate profit.

This is one of the problems confronting us. There are others of a more or less technical nature, and for their solution scientifically trained men will, in my opinion, be necessary. That we have many men engaged in the lumbering business who are highly skilled men indeed in the operation of removing the present standing crop of timber as expeditiously and economically as possible, is true, but their training is not extended to the problem of removing this timber with any regard to a future crop.

While we need scientifically trained men for this purpose, men with a knowledge of botany, plant pathology and general silviculture, as these men would have to be employed partly by the Government, partly by lumbermen, it would be necessary that in addition to these things they should also be expert lumbermen, and have a thorough knowledge of logging, driving to market, sawing, culling lumber, etc., so that in addition to the training they could receive in the schools, their education would be utterly incomplete without the other training in the bush and in the saw mill, as well as in the lumber yard.

For the proper management of our Permanent Forests, well trained men will be needed and it will require the joint training of the college, the bush and the saw mill to produce them.

THE COOPERAGE STOCK INDUSTRY OF CANADA

By JAS. INNES, Chatham, Ont.



JAS. INNES.

A GREAT many years ago, when the principal exports from Canada to the Old Country consisted of furs and timber, some enterprising Frenchmen (or possibly Scotchmen), who had come from our Motherland, being employed in the manufacture of barrels and casks, conceived the idea of getting out staves and heading in Canada for export to Great Bri-

tain. In those days the forests contained a great deal of fine white oak all the way from Quebec to Windsor, but more especially in the western peninsula, and those trees were cut down, squared up with a broad-axe and shipped to England, the consequence being that only the finest trees were used and only part of them, namely, the part that could be put into square timber.

This square timber was floated down to Montreal, loaded on vessels there for the Old Country, where it was used for the manufacture of lumber, and, I presume, staves also. This enterprising Frenchman or Scotchman no doubt saw the terrible waste which occurred by only using certain parts of the trees, and also saw the trees which were passed as not fit for square timber, but which would make excellent staves and undoubtedly this was the commencement of the cooperage industry in Canada.

Staves were taken out for the wine casks of France and Spain, and the whiskey casks of Great Britain and Ireland, and before long "Canada Butts" and "Quebec Pipe Staves" became standard grades in Great Britain and on the Continent.

At that time all of the sugar used in England came from the West Indies and was shipped in hogsheads, and the West Indies Hhd. Staves were also manufactured in Canada, shipped to England, where they were made into shooks and sent over to the West Indies to be filled with sugar, molasses and rum.

As the oak got scarcer in the east, the hewers and stave makers drifted west, until Chatham, Ont., became one of the great centres of the stave industry.

The old residents here have told the writer that years ago McGregor creek and Thames river, which converse at Chatham, would have its waters covered for miles every spring with square oak, walnut timber, Canada butts, Quebec pipe staves and West India Hhd. Staves, and the smaller and shorter pieces of oak, utilized for barrel keg staves and heading. These were loaded on vessel in the Thames river, sent down to Montreal, and in some cases sent direct to England from Chatham. This, of course, was entirely tight barrel stock, as in those days no slack barrel stock was exported from Canada, as being all made by hand it was too expensive to send over to the Old Country, which at that time was almost entirely supplied with Norway fir staves and beech staves made from the timber growing in England, Ireland and Scotland.

Mr. Neil Watson, of Mull, Ont., now a manufacturer of slack barrel stock, hauled staves from Harwick township to Buckhorn Beach for years and sold his pipe staves, 60 x 5 x 2", at \$25 per thousand, and West India staves, 44 x 4½ x 1", at \$5 to \$8 per 1,200 for shipment to England.

Tight barrel stock in Canada is now almost a thing of the past, the oak having been almost exhausted, and what staves are made here now are used entirely for local consumption, either being

made in the old way, which I will describe, or being sawed on a Drum saw.

The method of manufacturing in the early days, in fact it is still in use, was to cut the trees up into bolt lengths, according to the quality of the tree, whether suitable for long or short staves of heading, then to split these bolts with a Froe knife, and in some cases, such as "Canada Butts," dress them with a draw knife and ship them in the rough, sometimes taking the sap off, but other times shipping them with the sap on. Now most of the oak staves are sawn on a Drum saw, which does away with a great deal of waste, on account of the slips on the part of the workman with the Froe, and also enables the manufacturers to use tougher oak and timber which would not split freely with a Froe, in fact, work up everything very close. The buckler, for bucking staves, never got much of a foothold in Canada, as the timber was practically exhausted here before bucked staves were saleable on foreign markets.

Oak Heading, instead of being split now, is sawed, and while in the old days the head used to be split, finished off with a draw knife, marked off with a compass and sawed out by hand, the bevel also being put on with a draw knife, the heading is now sawed on a swing saw, piled in the yard to dry, put through a kiln when partially seasoned, run through a planer and turned up with a rounding machine, which puts on the bevel and turns the head at the same time. As already stated, the manufacture of tight barrel stock in Canada from oak is now almost a thing of the past, and does not figure very much in the export trade of Canada.

We will now turn to the manufacture of slack barrel stock. Years ago when the manufacturing industries in Canada were in their infancy and the consumption of barrels was a very minor matter, coopers made their staves and heading for flour and other slack barrels in the same manner as they used to make their tight barrel stock, in fact the same as a great many tight barrel staves and heading are still made in the United States.

The cooper would get his bolts in the winter, haul them to his cooper shop, split out his staves with his froe, and in the winter make the staves with a draw knife, jointing them on a planer jointer, in some cases even putting on the joint with his draw knife. At that time slack barrel staves were made almost entirely from red oak and basswood, the cooper making his staves during the winter months in his shop, seasoning them inside his barn or cooper shop, and making up his barrels as required, and after the staves were seasoned selling them from 75 cents to \$1 each. Coopering at that time was simply a side issue, the cooper being also a farmer, carpenter, or some other tradesman, and making all kinds of barrels and casks from a flour barrel to a water tank.

Years rolled on, the red oak forests of Canada became a thing of the past—what oak was left would bring very much higher prices for lumber or bending purposes, sawn timbers, etc., than it would bring for staves, and the same applied to the States of New York, Ohio and Indiana, which at that time were large stave producers. Some Yankee genius (sad to say unknown), possibly a man who thought there was a great waste of energy in making staves by hand, got his brains to work and invented the modern stave knife for cutting slack barrel staves from steamed bolts. The machine as at first invented is practically the same as is in use at the present time, the only improvements that have been made being that the machine is made twice as heavy as formerly, so as to be rigid and do away with the cutting of thin staves. A balance wheel was put on so as to make the strokes more regular, and the speed increased from 50 revolutions per minute, which was the original cut of the machine, to 150 or 160 revolutions per

minute, which is the speed at which the modern stave knives are run.

When this machine was first in use the staves were made entirely from red oak and basswood, the bolts being split out with a froe or axe, brought to the mill in this way and cut into staves. Immense elm forests then attracted the attention of some of the stave manufacturers and they experimented with making elm staves. It is not a great many years ago, only since I came to this country, that red oak staves were the principal kind used on the Minneapolis market, now elm is almost entirely used, in fact red oak staves are not liked on account of being so hard to work.

For a great many years nothing but split bolts were used, until some manufacturer, with a saw mill attached, conceived the idea of sawing his bolts, but until fifteen years ago staves made from sawn bolts commanded a lower price than staves from split bolts, as the coopers were of the opinion that staves could not be made straight grained unless the bolts were split, and it took a great many years to remove this erroneous idea. Now there is hardly a mill in the country making staves from anything but sawed bolts, and elm is the principal timber used, in fact is considered always desirable to any timber at the present time, although birch, beech, maple and Southern woods are now crowding elm by degrees off the market, on account of the high price of elm stumpage.

We will now turn to the hoop industry. Until about twenty years ago all of the barrels were hooped with what is known as half-round hoops. The cooper cut these hoops in the winter, hauled them to his cooper shop, and spent the long winter months when not making staves in making hoops for his summer trade. Then the raked hoop made from black ash came into vogue, this being the precursor of the modern patent cut elm hoop. For a great many years the hoops were made either raked or split from elm, and finished with a draw knife, until the idea was conceived of cutting the hoops the same as staves from elm plank, and this hoop was found, when it was perfected, to be superior in every way to the raked or bark hoop. It is still the principal hoop on the market, although on account of the scarcity of elm a great many wire hoops are being used to supplement the elm hoops on the barrels. The iron hoop alone does not give sufficient rigidity to a barrel, and if not supplemented with the patent hoop, the barrels when stored on the bolges would collapse without the assistance of the elm hoop.

Heading, which formerly used to be made in the same way as staves, split from bolts, dressed off with a draw knife, in fact the same as tight barrel heading, is now sawed on a swing saw, kiln dried and turned on a turning machine, at the rate of 3,000 sets per day to one machine, whereas formerly it was a very good cooper who would turn out 25 heads in a day.

While the tight barrel cooperage industry of Canada has declined, the slack barrel industry has leaped up until it is one of the most important industries in Canada, millions of dollars being invested in stave, hoop and heading mills all over the country from Nova Scotia to Ontario, and barrels being used for almost every conceivable purpose, as they are the handiest, strongest and best package that has yet been invented by man.

There is no doubt but there is timber in parts of Canada which are yet undeveloped to continue this industry for a number of years, and no doubt before the supply is exhausted methods of re-forestry will be inaugurated by the Canadian Government the same as are in vogue in Norway and Sweden. It is one of the greatest industries we have in Canada and should be fostered so as to continue in perpetuity.

A QUARTER CENTURY OF LUMBERING IN THE MARITIME PROVINCES

By CHAS. McINTYRE, St. John, N. B.



CHAS McINTYRE.

TO look back for twenty-five years to the conditions which surrounded the lumber industry of the Maritime Provinces at the beginning of that period and compare them with the conditions of to-day, one finds changes that speak eloquently of the ability and energy of the men who have been engaged in it during those years.

Perhaps the most marked change, at any rate the most important to the manufacturers, will be found in the difference in the dimensions of the logs being sawn to-day and those of the earlier date. The sawyer of the late seventies would have been astonished had he been asked to saw out a specification from such logs as are now being used. Half a dozen log surveys (spruce) chosen from a fyle at random and dated April and May, 1881, show nine pieces to the thousand feet; a like number dated April, 1904, show that 17 pieces were required to make up the same quantity.

Each winter as it came found the logging crews penetrating farther and farther into the forests that border the main streams and estuaries of the St. John River, the Miramichi and the Restigouche. Most of the ground has been cut over several times, but in nearly all cases long before the new growths had attained a size at all comparable with the original growth.

What the ultimate result of this retrogradation will be is hard to decide. On the St. John River, where the industry is the oldest, the results are beginning to be apparent in a slow but sure curtailment of the annual output. In other sections of the province the limits have not been worked for as long a period and the timber is therefore better.

One vital effect that is certain to follow a scarcity of large timber will be the lack of new blood and new capital in the industry; the virgin forests of newly settled countries are sure to attract those who have the desire and the means to devote themselves to the manufacture of lumber.

Already in Western Canada can be found many important plants the owners of which hail from the Maritime Provinces, and much capital belonging to residents of the latter provinces is involved in ventures of this kind in different parts of the west. Newfoundland is also attracting a great deal of attention. Its great forests of pine, many of them even unexplored, offer splendid opportunities. Several Nova Scotia firms are already operating and others are planning to do so in the near future.

The demands of the pulp manufacturers for raw material in the shape of undersized logs has had, during the last few years and will have in time to come, a tendency to still further reduce the average size of the available timber throughout the lower counties of New Brunswick and all other sections in the vicinity of pulp mills. The outlying districts will not suffer in this respect, as it would not pay to bring the material any great distance, as it would then be too costly. Heretofore trees that were not large enough to be manufactured into lumber were let stand until they had attained the necessary dimensions; nowadays in a great many cases they are cut for pulpwood, the anxiety to realize on them quickly being of course the chief inducement.

Another marked change is found in the great shrinkage in the annual output of pine in this province. It is due entirely to a scarcity of raw material. Until seventeen or eighteen years ago pine was the

staple, the American mills manufacturing little else. Year by year the quantity of pine logs cut has decreased until this year one million feet would easily cover the total manufacture on the St. John river. What logs there are, are small and of an inferior grade compared with those of the early eighties. At this latter time, provincial pine logs were worth from \$9 to \$12 per thousand feet at St. John, considerable variation being the rule owing to a corresponding variations in the size and quality of the logs. The value of pine logs such as were called ordinary in those days would probably be a great deal higher to-day were they obtainable. It is scarcely worth while to make any comparison with the prices to-day as there are seldom any lots of importance on the market.

As the pine became gradually scarcer, spruce became more in demand and more valuable year by year in spite of the gradual degeneration in size. This increase in value is due chiefly to three facts: The logs are harder to get, wages and supplies are more costly and stumpage rates have materially increased.

In the early eighties, spruce logs, that could not be duplicated in the provinces to-day at any price, brought from \$7 to \$8.50 per thousand at the mill; from this figure the price crept slowly upward until it reached \$12.50, which mark was touched last year. This year spruce logs are lower, but it is felt that the depression is only temporary and that the high prices of last year will again prevail in the near future.

For the past twenty-five years the market price of spruce lumber in the United Kingdom has been

usually worth \$2 more per M. because of their product, when they are manufactured by an American citizen, being allowed to go into the United States free of duty) were sawn into English sizes and shipped to the United Kingdom.

The high-water mark in prices was touched in 1903, when merchantable deals were sold in large quantities at figures that ranged from \$13.25 per M. to \$13.75 f.o.b. steamer at New Brunswick port. Early in 1904 the English market took a decided slump. Prices fell suddenly and emphatically until on September 1st purchases could have been made as low as \$11.50 per M., with the goods plentiful. That these low figures will be in evidence only temporarily is generally felt on all sides; nearly all of those most interested seem to have confidence in the probability that before many months have passed the purchase price of spruce deals for the English market will have climbed nearer to the figures prevalent in 1903, which in most opinions are, in view of the conditions bearing directly upon the industry at this particular period, much more normal than the prices current this month.

The general decrease in the dimensions of the logs being sawn, which was referred to earlier in this article, has had a marked effect upon the quantity of wide deals turned out and the result is that the difference in the percentage of wides in the specifications is very apparent and very important in figuring the value.

As to quality, the general impression seems to be that the lumber of twenty years ago excelled that which is being manufactured to-day. This is owing to the fact that the larger growth is almost certain



WATER POWER SAW MILL AT LITTLE SALMON RIVER, ST. JOHN COUNTY, N. B. This mill was built by C. M. Bostwick & Company and operated under their management until the sale, a few months ago, to the Bay Shore Lumber Company. This is the only mill of its kind in the Maritime Provinces which is fitted with thoroughly up-to-date machinery.

creeping up slowly but surely. The year 1879 was characterized by extremely low prices, several large lots being disposed of at figures that left from \$5.75 to \$6 per M. for merchantable. Of course, it would not be reasonable to use these figures as a criterion, for the year is recalled as one of light demand, heavy shipments and the consequent low returns mentioned above.

For several years following the trade showed a marked improvement both in prices and demand. A fair average price for the early eighties would be \$8.50 per M. for merchantable spruce deals, two-thirds for fourths and ends, at the mill in New Brunswick. From that time until the year 1900 prices rose gradually, interrupted of course by many periods of temporary depression due to the presence of unfavorable conditions, but always when the reaction set in, gaining a little more ground than had been lost. The end of the century found the figures in the vicinity of \$11.50 for merchantable. Then followed three very prosperous years. The demand during that period was extremely brisk and the shipments from the provinces were larger per year than they had ever been before, conditions being so favorable that in many cases American logs (that are

to be cleaner and to have fewer knots and twists. Of course, in making a comparison of prices this degeneration in size and quality is a very important element.

Changes that are important to American manufacturers more than to any others are those which have taken place in the vital conditions of the lumber markets of the Eastern States. Twenty-five years ago the consignments to this market consisted chiefly of pine, the greater part of which was made up of one-inch boards. To-day, for reasons mentioned in an earlier paragraph, the shipments of pine are few and light. With spruce it is exactly the reverse. In the late seventies and the early eighties, the shipments of spruce from the Maritime Provinces to the United States were of not very great importance; to-day spruce is the staple.

The spruce trade in this direction has also changed in that the smaller sizes have been much less in demand during the last few years; where before the demand was principally for plank and scantling to-day it runs chiefly to three-inch.

On the whole the variation in price has not been so great as in the case of the English markets, although sudden fluctuations are more frequent. In

making a comparison, it cannot be said that there is any improvement in price. There have been heavy advances and again sharp drops, but there has been no change that could be positively said to be permanent.

Perhaps the change that is most apparent to the unpractised eye will be found in the machinery used in manufacturing. In the early eighties the old-time water mill was no uncommon sight; to-day they are so scarce that it might be said they are extinct so far as their usefulness is concerned.

The improvements in mill machinery have come gradually. There has been no abrupt departure from the old methods. The gang was the pioneer of long lumber manufacturing machinery. In or about the year 1880 the first rotary made its appearance in the Province of New Brunswick. Since that time the number of these machines has steadily increased, although they are used chiefly in country districts in small portable or stationary mills. They also find great favor in the minds of many when used in connection with a stock-gang.

It is now about ten years since the band saw was first adopted, and while it has grown steadily in favor on account of its thin cut and consequent saving of material, the gang still has many partisans. Of the improved double-cut band saws there are very few in this section of the country.

Another important change which has taken place in the last quarter of a century will be found in the price of labor. Twenty-five per cent. would probably cover the actual outlay in cash, but when it is considered that the ten-hour and sometimes longer day has now been changed (by means of strikes in nearly all cases) to a nine-hour day, the increase takes on still larger proportions.

Freights by water to all points and by all sorts of shipping are much more favorable to the shipper. Twenty-five years ago 60s. per standard on deals to the West Coast of England was about the average rate, and \$3 to Boston per M. s. ft. was quite ordinary. Charters have been made to the West Coast this season as low as 32½s. per standard, while to Boston \$2.25 per M. has been the prevailing figure.

A review of the whole situation from a financial standpoint leads to the following conclusions:

Lumber of all kinds, manufactured in the Maritime Provinces, has netted during the last ten years probably 20 per cent. more than was the case during the preceding ten years. In spite of this fact it is

sum has gone yearly to the Department of Mines, Forests and Fisheries and to the private owners of lumber lands in the shape of the increase in stump-age rates.

MILLS AND PROPERTIES OF THE SHIVES LUMBER COMPANY.

We present in this issue several views of the mills and lumber operations of The Shives Lumber Company, Limited, doing business in the town of Campbellton, New Brunswick, and vicinity.

The company have three mills: a long lumber mill

engine house and burner foundations are concrete.

The machinery of the mill consists of a rotary carriage and twin circular for slabbing the logs for the gangs. The gangs are placed on massive concrete foundations, and are not connected with the mill frame. They were made by the firm of Wickes Brothers, Saginaw, and are massive and strong and capable of doing an immense amount of work. Each gang weighs 29 tons; one is 46 inches, and the other 48 inches inside. There are two large double edgers with divided rollers, which give them a capacity of four ordinary edgers, as two edgermen can work at each machine. There are two re-saws for sawing



SHIVES LUMBER COMPANY—ATHOL MILL FROM INTERCOLONIAL RAILWAY TRACK.

at Athol, two miles above Campbellton on the Restigouche river, and two mills in the town. The mill at Athol is one of the largest and most modern in the Maritime Provinces. It is 265 feet long and 65 feet wide, with two large sorting sheds in which the lumber passes over travelling chains on to the sorting tables, is sorted in sizes and qualities, placed on small cars and taken out to the piling ground on elevated tramways and lowered down on the piles.

The engine room contains a 450 horse power engine, a dynamo engine driving the dynamo for supplying light to the mills and houses, and for driving a planing mill which is situated some distance from the main mill, and which is driven by motors. The engine and boiler houses are brick with iron rafters

slabs into boards and planks, and another edger for edging any waney boards coming from re-saws.

The lumber after leaving the gangs and edgers moves over the trimming tables to the sorting sheds and thence to the piling ground. From the time the logs come into the mill until lumber is put on the piles every modern labor saving appliance has been used to handle the lumber, waste, etc., quickly and cheaply, and to save as many men as possible.

The mill also contains a double clapboard machine, sawing two bolts at the one time, each machine having a capacity of seven thousand pieces per day. The clapboards are air dried, taken to the clapboard planing mill, and placed into bundles for shipment to the United States and local market.



SHIVES LUMBER COMPANY—ATHOL MILL BEFORE SORTING SHEDS OR TRAMWAY WERE BUILT.



SHIVES LUMBER COMPANY—SHINGLE MILL AT CAMPBELLTON.

well known that the profits of the men who own and operate the manufacturing plants were no larger during the latter period than during the former; indeed it is a question if their gains were as great. Part of this increase in returns, and an important part, has gone to the laborer, the chopper, the log-driver and the mill-hand. The manufacturers of logging implements, the builders of mill machinery and the dealers in lumbermen's supplies have each had a substantial portion of what is left. A large

and galvanized iron roof, both entirely separate from the main mill.

The steam plant consists of a battery of five tubular boilers with brick ovens in front. The fuel consists of sawdust, which is fed automatically into hoppers over the top of the brick ovens.

A refuse burner 130 feet high and 28 feet in diameter, built of steel and lined with firebrick, consumes all surplus sawdust and waste wood from the mill. All the engine rooms, shafting, boiler houses,

The lath mill contains two bolters and two lath machines, and has a capacity of from sixty to eighty thousand laths per day.

There are also a number of smaller machines in connection with the mill for cutting waste into shingle binders, heading, box stuff, etc., thus utilizing the trimmings and waste ends.

The capacity of the mill is from 150,000 to 200,000 superficial feet per day of ten hours, according to the kind of lumber sawn.

The mill is protected from fire by a large Underwriter steam pump with a capacity of 750 gallons per minute. Iron mains from the pump run to all parts of the mill and yard.

The machine and repair shop is driven by separate boiler and engine, and contains two large lathes, iron planer and drilling machine. In connection with the same there are blacksmith and carpenter shops. There is a fine boarding house which will accommodate one hundred men, also sixteen tenement houses.

The log pond at Athol is a very extensive one, and has a holding capacity of about seven million superficial feet. The logs do not have to be rafted, but are sorted direct from the Restigouche Boom Company's booms into the mill boom.

The larger Campbellton shingle mill contains ten shingle machines and the other one four. Both mills have a daily capacity of 250,000 shingles. They have each good booms for holding logs, and plenty of room for piling out sufficient cedar to keep them going during the winter months. In connection with these mills are sheds that have a piling capacity of about fifteen million shingles. In connection with the larger shingle mill there is a well equipped box plant and dry kiln, and a tie-sawing machine by which ties are manufactured, the company making a large quantity of these.

This season the company has shipped considerable lumber to Australia and South America, as well as the United Kingdom; all the shingles, clapboards and lath being marketed in the United States and the Provinces.

The most important feature of this company's enormous plant and property is their extensive timber limits, comprising 884 square miles, situated along

A RETROSPECTIVE GLANCE BY A LUMBER SALESMAN.

By JOS. OLIVER.



JOS. OLIVER.

IN giving my experience as a salesman for the last twenty-five or thirty years, I presume it will largely consist of a history of the changes in the mode and manner of distribution of lumber during that time.

Prior to the year 1870 the wholesale lumber business was done almost entirely from yards, Colwell Bros. and Thompson, Smith & Sons being the two largest dealers in the city, the builders and planing mill men going to either one or other of them and selecting such piles as they wanted and having them marked up to them. About this time the late S. R. Briggs conceived the idea of selling in carload lots to the builders and planing mill men, and he thus became the pioneer in this line of business, which has since developed to its present large proportions.

About the year 1873 I entered his employ. The lumber handled by this firm came very largely from small mills scattered all over Northern Ontario, from

S. C. Kanady Lumber Company, and Mr. N. Dymont, of Barrie. The latter gentleman was then and still is the most aggressive salesman that ever went on the road, and other salesmen always liked to be in town just a little ahead of him. We sold lumber all the way from Toronto to Windsor, and shipped by rail. Since that time the shipments from here by water have practically ceased, and instead of shipping out of here, the reverse is the case, as several cargoes have been received during the past season.

The trade on the North Shore began to be developed about 1880, and wholesale yards were established at Point Edward, Sarnia and Windsor. From these points a very large trade has been carried on for some years, and as is well known, during the last few years saw mills have also been established at Sarnia, which are doing a large business.

Buffalo and Tonawanda have also developed into very great lumber centres during this time, and have cut very largely into the eastern trade that was done via Oswego; in fact, the whole trade has changed and to-day men in the business out west can have their wants supplied from day to day instead of having to order in great quantities as they did in former times. Along with those advantages have also come the very great advance in prices. During that time lumber has advanced over 100 per cent., which indicates that our country is advancing very rapidly and the visible supply of timber getting smaller every year. We have now to go away south to get our requirements for bill timber, and before very long I expect to see a great deal of our supply, especially of bill timber, coming from our own British Columbia.



SHIVES LUMBER COMPANY—IN THE SPRUCE WOODS.



SHIVES LUMBER COMPANY—IN THE CEDAR WOODS.

the Main Restigouche, Quataouam, Kedgewick and branches of the Restigouche, and on numerous smaller streams; 658 square miles are in the Province of New Brunswick and 226 in Quebec. The streams are all smooth and good to drive logs to the corporation booms three miles above Campbellton.

There is a good growth of timber on the lands, consisting of spruce, pine, fir, cedar, poplar, birch and maple. The spruce and cedar are at present the principal cut, the trees being of a very large size and superior in quality to most found in Eastern Canada. The lands are all green and very free from fire risk, being at a considerable distance from settlements, and there has never been a fire on any of the company's limits. Although most parts of New Brunswick and Nova Scotia suffered in 1903, which was a very dry season, no fires occurred on the Restigouche or any of its tributaries.

The product of the mills is shipped at the port of Campbellton, which is a cheap and safe port. Included in the many vessels loaded the past season were three large steamers that carried over three million feet each, and sailed from the wharf drawing twenty-one feet.

Collingwood, Penetang, Orillia and points south of there. All the large mills, such as Thompson, Smith & Sons, Bradford; Beecher & Silliman, Belle Ewart; Thompson & Miller, Longford; Georgian Bay Lumber Company, Waubesa, and Peckham & Hoag, Collingwood, shipped a large proportion of their lumber to Oswego and Albany, the latter point being the general distributing centre at that time.

Practically all the lumber came down the old Northern Railway and was shipped by vessel to Oswego and from there to Albany by canal. About this time the new Welland canal was being constructed and a very large trade was done by vessel to Port Dalhousie, St. Catharines and Thorold; in fact all south shore points, including Rochester, Syracuse and Utica were supplied in the same way. The western trade was done by transshipping lumber to the Great Western Railway at Toronto, the gauge of the two roads being different.

Lumber salesmen had rather an easier task selling those days than at present. There was not the same competition as there is now, in fact I can only recall a few men who were on the road at that time and are still in business, Mr. A. R. Riches, of the

To sum up, I think we have developed the sorting and selling of lumber to such a point that we can now give a purchaser anything he wants in the lumber line, and thus prevent him from having to buy a large quantity of material he does not require. In conclusion, allow me to say to you how much we appreciate the efforts that are being put forth by the "Canadian Lumberman" in every way advance the interests of the trade.

NATIONAL WHOLESALE LUMBER DEALERS' ASSOCIATION.

The thirteenth annual meeting of the National Wholesale Lumber Dealers' Association will be held at Philadelphia, Pa., Wednesday and Thursday, March 1 and 2, 1905. The Association headquarters at Philadelphia will be the large and commodious hotel, "Bellevue Stratford," and with the arrangements in effect, members will be able to attend the business meetings without inconvenience, as the convention hall is located in the hotel and is easily accessible.

A MODERN SAW MILL IN WINNIPEG.

It would probably be impossible to find a more complete saw mill outfit than that which has been installed at Winnipeg by the D. E. Sprague Lumber Company, Limited.

It is now just about a quarter of a century since the present president first started in a modest way to supply Winnipeg demands for lumber, and thus established the foundation of the present gigantic business. Like most of Winnipeg's pioneers he hailed from the east, leaving his native place in York county, Ontario, in 1872, attracted by the western prospects.

From modest beginnings, the advance has been met from time to time by the installation of machinery to meet the demand, until at the present moment it is equipped second to no other mill in the Dominion.

The latest addition to the plant was the recently perfected "horizontal band saw," which is believed to be the only one at present in operation in Canada, and the ease with which the largest and most cumbersome of logs is manipulated is truly marvellous. This particular machine has a capacity of 90,000 lineal feet per day of 10 hours.

The complete working of the mill, from start to finish, is of the greatest interest; devices have been arranged at every point to make the working of the various machines as effective as possible. The principal wood-working machines are arranged on the second floor of the building, and one can stand by the river side and see the immense logs being guided to the "Jack Ladder" and pass up to the second floor entrance and disappear as though by magic, to all appearance unattended by human help. Passing round to the opposite side of the mill, one is again amazed to witness finished lumber of all kinds and dimensions emerging from the building, apparently at its own sweet will, and passing down the sorting platform at various stages, where men are stationed to stack each piece in its respective location.

Passing inside the building, the perfection of the detail arrangements is immediately apparent, the men employed, for the most part, having the appearance of looking on and watching the various processes, instead of being actual workers, so complete is the machinery employed. As the log enters the building from the jack ladder previously noticed, it passes on to a system of rollers, all the smaller and unimportant stuff passing to the left to be treated for cordwood, whilst that turned to the right is passed to machines for more pretentious uses.



SPRAGUE LUMBER COMPANY, WINNIPEG—GENERAL VIEW OF LUMBER YARD AND SHED, WITH MILL IN THE DISTANCE ON THE LEFT.

The cordwood machinery in operation is of great interest, as in addition to having the familiar circular saws, which cut up into the usual 16-inch and 4-foot lengths, there is a machine of unique construction specially devised for this mill, which consists of two heavy chopper blades, which are used for splitting the cordwood for stove purposes. This machine has a capacity of some 40 cords of wood per day of 10 hours.

Turning again to the jack ladder, one sees the large logs passing on to the rollers to be at once seized by two immense iron arms, called kickers and riggers, which rise up from below by the manipulation of a lever, and flings the log bodily on to the flying platform carriage, which in its turn grips and carries the log to the saw. The working of these two

machines is marvellous; the effect produced by the arms rising, clutching the immense log, and turning or partly turning it and then pushing it along, is apparently of life rather than of inanimate machinery.

These machines, and also the carriage which flies at a great pace, are worked by direct steam pressure, at upwards of 90 pounds. From this point all lumber is passed on an endless chain conveyor and carried to its particular operation; it is then that the advantage of the improved horizontal saw comes into prominence; the large and important logs are carried on revolving rollers to the horizontal saw and cut up into lumber. One of the remarkable features of this machine is its greater rapidity of cutting, while at the same time the work it does is stated to be better and more clean cut than is the case with the circular saw.

The further equipment of the mill consists of an up-to-date gang edger, with almost a network of endless conveyers carrying slabs and refuse to various receptacles whence they pass into hoppers ready for storage, whilst the prepared lumber passes, as before-mentioned, by a system of powerful endless chains to the sorting platform, which is upwards of 200 feet in length.

The company have carried out the system of live rollers for loading to great advantage, so that one man can accomplish with ease a task which under usual conditions would require several men.

The sorting platform is equipped with a long roller device, so that a stack of lumber can be easily passed onto the rig without the necessity of unstacking. The rig itself is also fitted with the roller device, so that by turning a handle the whole load can be rapidly passed off when unloading.

In addition to the saw mill, the company have also an excellently equipped planing mill with all the necessary machinery for the manufacture of moulding stock and re-sawing. A dry kiln with a capacity of some 50,000 feet, is also a part of the equipment. The saw mill has an easy capacity of some 100,000 feet per day, and upwards of 40 cords of wood.

An important feature, and one which the company has successfully maintained, is their determination and to accomplish this they have made provision to carry an abundant stock of all lumber in demand, against all climatic conditions. They have just completed the erection of their fourth dry storage shed, which will then give them a capacity for storing



SPRAGUE LUMBER COMPANY, WINNIPEG—INTERIOR OF MILL FROM THE LOG DECK; WOOD MACHINE ON THE LEFT.

under cover some 5,500,000 feet of matched and upper grade lumber, whilst their stock of weather stacked lumber covers many acres. The whole acreage of the company's property is now nearly 40 acres, right in the main manufacturing part of the city.

There are about 250 regular employees of the firm, and a stud of 74 horses is employed in the company's business.

Recently the company installed a complete electric

as it tends to cool them and reduce the boiler efficiency accordingly.

Look after this matter closely, for otherwise it may cost somebody several tons of coal. It is necessary to have one or more castiron doors by means of which ashes and soot can be removed, and these do not always shut tight enough to exclude air, hence they may be a source of loss.

It is difficult to prevent cracks from appearing in

study of the needs and requirements of the shingle manufacturer. That they have stuck to their original idea of turning out superior shingle machines that stand in the front rank, is probably best attested by the fact that Perkins' machines are to-day in use in every civilized country on the globe, working successfully in every kind of wood. A request will, no doubt, bring any interested party a copy of this catalogue, which should be in the hands of every mill

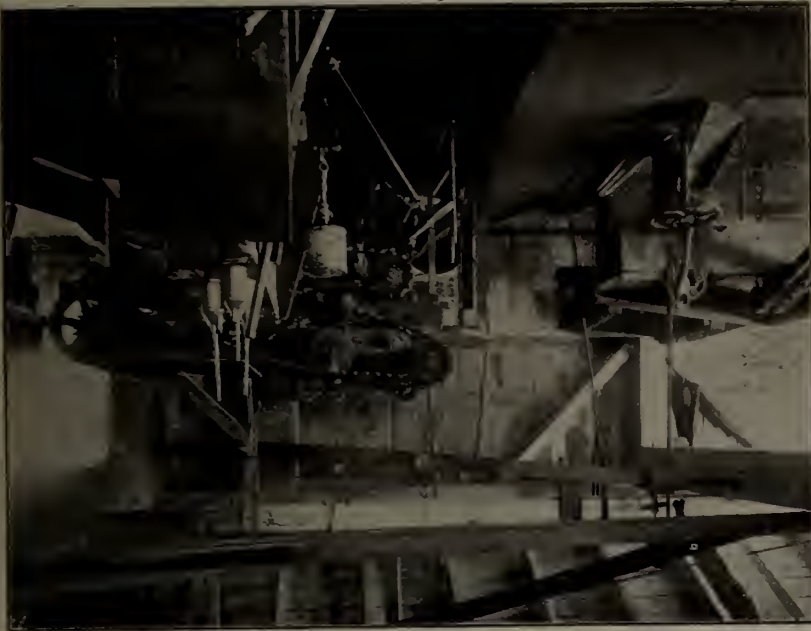

SPRAGUE LUMBER COMPANY, WINNIPEG—VIEW OF HORIZONTAL BAND SAW.



SPRAGUE LUMBER COMPANY, WINNIPEG—VIEW OF INTERIOR OF PORTION OF DRYING SHED.

light plant, which was supplied by the Canadian General Electric Company, and the whole of their factories, together with storage sheds and yards, will be well lighted, to enable the company to run a double staff of men, thus ensuring continuous working by day and night, a condition which the company has had to face quite frequently.

BRICK BOILER SETTING.

Wherever it is desired to get along with the least possible consumption of coal in a steam plant, care

the average boiler setting, but it is possible to close them with cement, mortar or loose asbestos mixed with water to the consistency of stiff mortar.

THE SCIENCE OF SHINGLE MAKING.

Thirty-two years making shingle machinery. Truly time and results best tell the story of achievement, and a glance through the new XXXX Catalogue, just issued by Perkins & Company, the pioneer shingle machinery concern of Grand Rapids, Mich., shows a line of shingle producing machinery of every descrip-

man, foreman and manufacturer of shingles, heading or box boards. Address the manufacturers, Perkins & Company, Grand Rapids, Mich.

It is surprising to note the prejudice a large class of woodworkers have against the use of the emery wheel for sharpening saws, when it is a positive and established fact that the cost of sharpening with emery is not one-twentieth that of the file for the same purpose, and the work can be done very much quicker. The idea that the automatic grinder is all



SPRAGUE LUMBER COMPANY, WINNIPEG—GENERAL VIEW OF PART OF LOG YARD.



MR. D. E. SPRAGUE,
President Sprague Lumber Company.

should be taken to know that there are no cracks in the boiler setting whereby cold air can rush in where it is not wanted.

It is a very good idea to provide plenty of fresh air in many places, including the furnaces of our steam boilers, but when large quantities of it are allowed to go into the side walls and thence find its way to the hot gases as they travel under a boiler, it is sure to prove detrimental to the service,

tion that is well calculated to bear out the claims of this firm for turning out the best machinery in their class, and one that fully proves that they have reduced the making of shingles down to a science.

This new catalogue, containing what is claimed to be the most complete and comprehensive line of hand feed, single, double and ten-blockers and other shingle mill machinery ever issued, plainly shows the result of their thirty-two years of concentration and

that can be used is not well established, for in fact a man used to grinding by hand can do it quicker and quite as well. If the table is set properly, he always grinds square across, and can keep his teeth to even length and give them all a uniform pitch, three very essential points in the care of saws. The table, to do this, should stand parallel to the shaft, just even with the centre of it, and squarely to it. A little care with the right kind of a wheel prevents burning.

MODERN METHODS OF SAW MILLING.

Some of the most modern and yet practical ideas have been adopted by Messrs. Wm. Cooke & Sons, of Hillsdale, Ont., in their lumbering operations. One of these is a saw mill on wheels, which, so far as we know, is the first of its kind in Canada, if not in America. The increasing difficulties connected with carrying on logging operations in winter, and a natural disposition to devise plans to minimize the amount of manual labor required for a given purpose,

ports the mill. There is a space of six inches between the two bearings and the flanges of the wheel, so that the wheel may travel back and forward around a curve.

The wheels are placed on a railroad rail which is spiked to a 6 x 10-inch timber, as shown in the illustration, which timber is laid on ties 3 x 10 inches, of lengths varying from four to fourteen feet. The mill is moved by means of the block and tackle, the power being furnished by the engine which operates the mill.

cost of the lumber, from the stump to the finished product, is said to be only \$3 per thousand, which undoubtedly represents a large saving.

Nothing but sawdust is used for fuel. In this connection some particulars may be given of the construction of the boiler furnace, which embodies new ideas. The boiler is equipped with a Dutch oven in



MOVABLE SAW MILL OF WILLIAM COOKE & SONS, HILLSDALE, ONT.

led Mr. Wm. Cooke, the senior member of the firm and one of the pioneer lumbermen, to build a mill which could be transported to the timber rather than the timber being brought to the mill, and his efforts in that direction have been most successful.

This movable mill is built in the same manner as any ordinary stationary mill, with engine and boiler, lumber, shingle and wood-cutting machinery in one frame. The bottom story is of frame 70 feet long and 12 feet wide, and has two bents running lengthwise built and bolted strongly together like the trestle

The capacity of the mill when running full handed is 25,000 feet of lumber, 20,000 shingles, and as much cordwood as is on the ground where the timber is cut; in fact, the land is cleared of everything but brush. When the timber for a distance of about 200 feet is cut out, the mill is moved along to a new location and the process repeated. The longest haul would not be over 300 feet.

Messrs. Cooke & Sons operated the mill this fall for about a month, during which time it was moved three times. They found that it possessed many

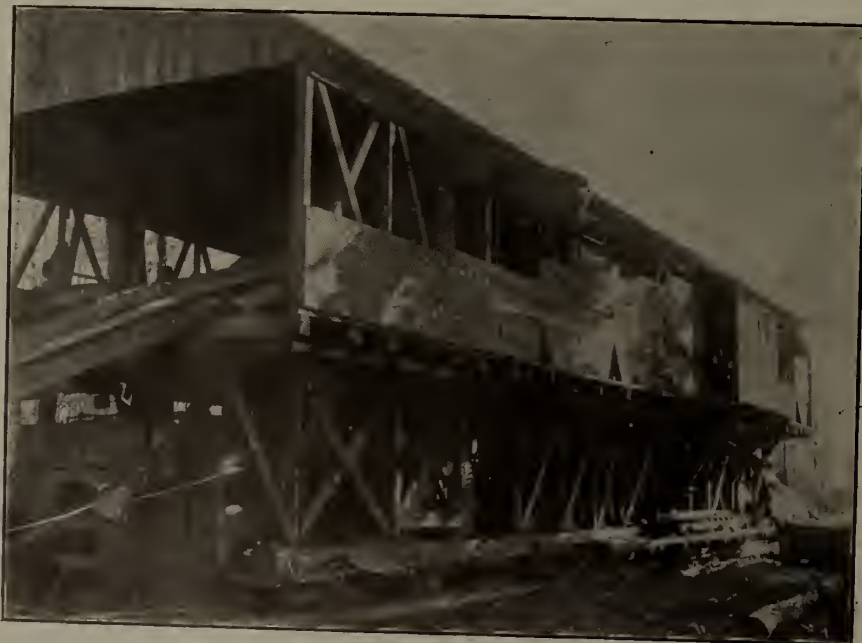

MOVABLE SAW MILL OF WILLIAM COOKE & SONS, HILLSDALE, ONT.—SIDE VIEW.

work of a bridge, making it very strong and rigid. The engine, boiler, shafting, shingle and wood-cutting machinery are on this lower floor.

The upper story is 70 feet long and 18 feet wide, and is simply a plain floor where the lumber sawing machinery is placed. The roof is supported with studs of 2 x 4 hemlock and braced under the two sides. Running lengthwise of the mill are five wheels with flanges on each side 11 inches in diameter, and through each wheel extends a short shaft 2 1/2 inches in diameter with a bearing at each end which sup-

advantages over the ordinary method of lumbering, the most important of which is probably that winter woods operations are eliminated, and the cost of logging reduced to the lowest possible point. The mill is so constructed that a person standing in the mill can see every man at work, both in the bush and in the mill.

The jack ladder and one-half of the skidways are moved along with the mill on wheels, and the time required for moving the mill and getting it ready for operation again is usually less than two hours. The

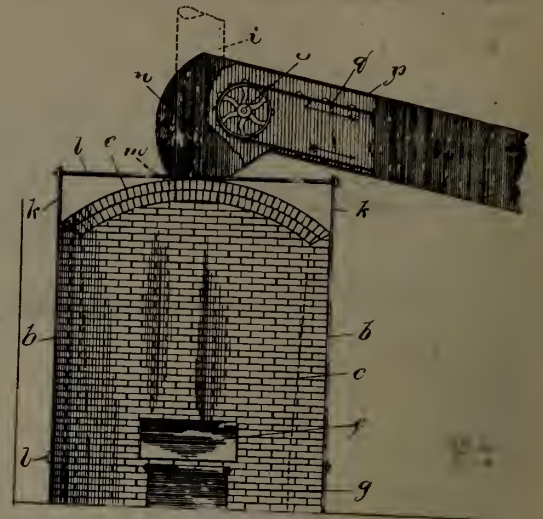

Fig. 1
WM. COOKE'S IMPROVEMENTS IN REFUSE BURNERS, SHOWING BURNER AND CARRIER.

front, made of No. 12 sheet iron, cased inside with 4-inch firebrick wall and arched over with firebrick. Extending through the arch is a sheet iron spout with an automatic damper which permits the sawdust to drop down as the conveyors bring it from the saw. The fire leaves the oven and passes direct through the tubes, then returns along the side and bottom of the boiler to the smoke stack. The sides of the furnace, after it leaves the oven, are a square box made of No. 17 sheet iron without any casing inside,

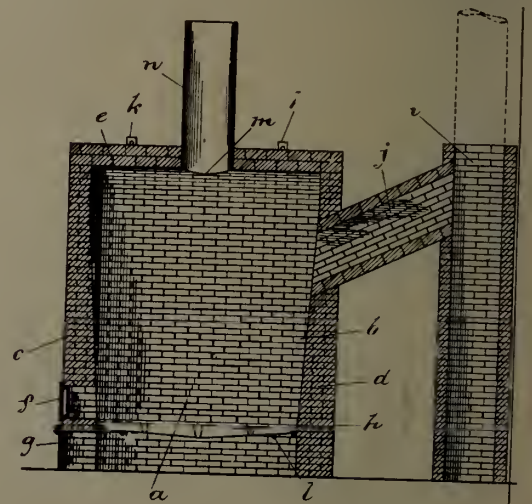

Fig. 2
WM. COOKE'S IMPROVEMENTS IN REFUSE BURNERS, SHOWING BURNER ATTACHED TO SMOKE STACK.

but with a space of three inches on each side and eighteen inches in the bottom.

Messrs. Cooke & Son have applied for a patent for this method of constructing a furnace, as they have found it to be most economical. They thoroughly tested it with their mill, which was burned down early last spring. The refuse burner in connection with this mill was constructed like a large Dutch oven, being 12 feet square outside. The side walls were made of common brick 12 inches thick and 14 feet high, with damper and furnace doors and arched over with brick. The grates were set two feet above the ground and in the centre of the arch or roof was a cast-iron frame, while over the frame there was a large hopper into which the refuse conveyors dumped the refuse. From one of the side walls a large brick flue extended out 16 feet, almost horizontal, which connected the burner with the smoke stack. This size and kind of refuse burner will consume all the refuse from a mill cutting 60,000 to 70,000 feet per day, and is claimed to be absolutely

safe from fire, everything being consumed, even to the smoke. The cost of construction is about \$400. ✓

At Mr. Cooke's suggestion, the Haliburton Lumber Company remodelled the furnace of their mill upon the plans outlined above, and say that they saved \$600 in three months' operations.

Mr. Cooke has also invented a bolter for cutting shingle bolts from cedar logs which he claims will save 20 to 25 per cent. of timber over the old method of drag sawing the bolts.

A SCOTCH LUMBERMAN IN NOVA SCOTIA.

During the past five years a remarkable period of development has been experienced in the lumber industry of Nova Scotia and Newfoundland. Capital, everywhere, attracted by the prosperity of the industry, has sought chances for investment in the forest wealth of both countries, so that lands which five years ago were given away by the governments as Crown lands upon payment of 40 cents an acre, or which were to be bought at the price of one dollar per acre, to-day command from three to four dollars an acre and are eagerly sought for at that.

This tremendous influx of capital has been accomplished by the settlement of many experienced and well-known lumbermen from Ontario, the United States and a few from Great Britain, whose operations have been watched with the keenest interest by the lumbering public of the Maritime Provinces. Chief among these, ever prominent in the public eye from the day on which he started operations in Newfoundland in the year 1900, stands the sterling and



MR. LEWIS MILLER.

honest figure of Lewis Miller, head of the firm of Lewis Miller & Company, Limited, one of Britain's foremost lumbermen.

Mr. Miller, who is now operating a large mill at Ingram River, N.S., besides a large business in Great Britain and in Sweden, was born at the town of Crieff, Perth county, Scotland, in the year 1848, where he was educated at the Crieff Academy, which he attended up to the age of fifteen. At that age, with true Scottish confidence in his ability to succeed, he started business for himself in the lumber trade, operating a small mill near his native town of Crieff. Success followed in his footsteps from the start, while year by year the business was developed by the extension of operations and the addition of more capital, until he had as many as a dozen mills working in various parts of Scotland. Crieff still continues to be the headquarters of Mr. Miller's operations.

In the year 1882, convinced of the prospects of an increased demand for Swedish timber in the British market, Mr. Miller purchased extensive forest areas in Sweden, and energetically set to work to cater for the demands of his fellow countrymen in Britain. He built mills, worked them on economical and paying lines, and very soon succeeded in developing a vast export business and gaining recognition as one of the largest exporters of the country, and as a man to be reckoned with in the councils of the Lumber Association of Sweden, which is recognized as one of the strongest associations of its kind in the lumber countries of the world. So vast indeed has the extension of his business become in Sweden, that he has exported from time to time as much as 40,000,000 feet annually, but as the Swedish forests were getting very much depleted he, in 1900, turned his

attention towards Canada in the search for an opening for his sons, who follow the lumbering instincts of their father. He purchased extensive forest areas about the centre of Newfoundland and at Glenwood and Red Indian lake, built two large mills and the village of Millertown on the shores of the Red Indian lake, and soon had in operation the largest industry of its kind in the island, manufacturing at the rate of 170,000 feet of lumber per day of ten hours. However, on receipt of a first-class and very good offer from an American syndicate, he, in the spring of 1903, sold out his interest in Newfoundland. This American syndicate has now sold part of the Newfoundland property to the Harmsworths of London, who intend to erect large pulp and paper mills there. In October, 1903, Mr. Miller turned his attention towards Nova Scotia, where he purchased the properties owned by the Dominion Lumber Company, which included a mill at Ingram Doeks, twenty-five miles from Halifax, and 80,000 acres of good timber lands heavily clothed with spruce, white hemlock and pine. Since taking possession Mr. Miller has had the mill thoroughly overhauled. He commenced operations in June. The capacity runs in the neighborhood of 80,000 feet per day. A dry kiln with a capacity of 20,000 feet per day forms a valuable addition to the property. Mr. Miller hopes to manufacture with the commencement of next season's operations from ten to fifteen million feet annually, all of which he intends to export to the British market. Speaking to the writer, a member of our staff, on the condition of the British market and the export trade of the Maritime Provinces, Mr. Miller said: "The British market is in a bad state, caused by large over-production in Russia, Sweden and Canada. The lumbermen of the Maritime Province during the past three or four years have been securing big prices for their stocks, deals having gone up from \$10 to \$15, with the result that everybody has produced too much, there being more lumber on hand than the British market requires. Under such conditions the bulk of the Nova Scotia, New Brunswick and Quebec exporters are sure to lose money this year, as with the increase in prices during the period mentioned, came an increase in the cost of production, the cost of labor in Nova Scotia alone having increased about 25 per cent. Five years ago labor in Nova Scotia stood at \$16 a month, while to-day it stands at \$26 a month. Under the old price of labor it was possible to make a small margin on deals at \$10, but at the present cost of production it is practically an utter impossibility to even produce them at that figure. I can see no likelihood of immediate improvement until the manufacturers combine together to reduce production during the next few years. In striking contrast to the disjointed efforts of Canadian manufacturers, one turns to Sweden, which exports over one million standards per annum. Here the manufacturers have, during the past five or six years, had an association for the purpose of regulating production, and efforts in that direction have been attended with great success. What we need in Canada is combination on the part of exporters, and I venture to say that we would soon secure profitable prices and prevent our forests being so rapidly exhausted. In conclusion my final word to the lumbermen is that if they will only agree to decrease or curtail the output by at least 25 per cent. we would not have to wait twelve months before prices would rise again to their former level."

THE LUMBER DEMAND IN SOUTH AFRICA.

By J. G. JARDINE, OF CAPE TOWN.

No doubt it is known to the readers of the CANADA LUMBERMAN that business of all and every description throughout South Africa at present is particularly dull. The building trade has been decidedly quiet, as owing to a great deal of over-speculative building during the last year or two there appears to be no money to invest in buildings at present.

As regards the future outlook I cannot say I look for much change for some little while. Cape Town itself has a very limited market for timber for building purposes and also for the prepared lumber that might come from Canada. There are very few local manufacturers who consume any quantity of timber.

Further, there is no timber imported into Cape Town to be sent up country to the other colonies, as is done from the other coast ports, Durban, Port Elizabeth, East London and Lorenzo Marques. From time to time previous to the war an occasional cargo or two of spruce deals was imported into Cape Town from the Dominion. The importation of these was entirely dependent upon the prices of the timber market in the Baltic. When the Swedes had a limited production in any one year and prices were run up beyond a certain limit there was then a chance for two or three cargoes to be consumed in Cape Town and the neighborhood; and much the same can be said of the other coast ports named. Of more recent years, however, attention has been given to Oregon pine from the Pacific coast, owing to the prices of this, as well as the fact that cargoes of this timber can be obtained with a great number of long lengths. This Oregon pine comes as often as not from British Columbia, and we do not think, judging from the present state of affairs, there will be any chance of cargoes of spruce deals, etc., from the Eastern District of Canada to compete with this timber.

Regarding the prepared lumber, which sometimes comes forward from New York in small parcels, the consumption at present is so very little in the Cape of Good Hope, and competition so very keen, that it is very questionable if anything very much could be done from Canada at any rate for a time.

Merchants generally are well aware that a great deal of this lumber that comes from New York has originally been brought down from Canada, but hitherto even with this before them they have not been able to see much chance of passing orders to Canada for direct shipments.

The great bulk of timber reaches South Africa from the Baltic and the Pacific coast by sailing vessels. New South Wales is also coming to the front in hardwoods, such as blackbutt for sleepers, wharf and bridge piles and girders; also the Jarrah wood from Western Australia for street paving, etc. It is claimed for Australian hardwoods that they are resistant to the "white ant," a most destructive pest out here; and this is the reason given by the railway authorities for preferring Australian woods for sleepers and bridge work from timber of other countries. But making every allowance in this respect, I am strongly of the opinion that Canadian exporters, if they will, are able to supply anything from a "butcher's skewer to a cabinet organ," in the manufacture of which wood is an important factor.

When Johannesburg shortly obtains a good supply of colored labor in the mines and the depression vanishes, the demand will be great for all kinds of timber, prepared and unprepared, and the same can be said for many of the other towns in South Africa.

I append the names and addresses of several prominent timber dealers of wealth and standing at different points in Africa, all of whom are desirous of trading with Canadian timber firms, all things being equal:

- Ardene & Co., Cape Town.
- Phillip Bros., Cape Town.
- J. C. Smith & Co., Cape Town.
- Wm. Anderson & Co., Cape Town.
- J. C. Steytler & Co., Cape Town.
- T. W. Beckett & Co., Pretoria.
- Hunt, Louchers & Hepburn, Johannesburg and Durban.
- Wm. Hoskin & Co., Johannesburg.
- W. F. Johnston & Co., Johannesburg and Durban.
- Lingham Timber and Trading Company, Johannesburg and Lorenzo Marques.
- Parker, Wood & Co., Port Elizabeth, Johannesburg, Kimberley and Durban.
- Reynolds & Son, East London.
- D. Whitelaw & Son, Maritzburg and Johannesburg.

QUICK RETURNS.

An advertisement in the "Wanted and For Sale" Department of the WEEKLY LUMBERMAN is a profitable investment—expenditure small, results sure and quick. This has been the experience of hundreds of advertisers. Why not you? If you have lumber for sale try a trial advertisement.

THREE MEN IN THE WOODS.*

BY JAMES BARR.

"This is the region for big-game shooters," declaimed Peters. "No other can compare with it. In the air eagles, wild geese, duck galore; in the woods moose as big as horses, bear, caribou, deer; in the waters maskinonge, alligators, sturgeon—"

"Alligators?" queried McWhinnie.

"Yes, alligators," repeated Peters.

"In these waters?" inquired McWhinnie, sceptically, sweeping his hand towards Quinze Lake.

"Certainly, in these waters. There is no catch, McWhinnie. I tell you that in this lake are alligators," said Peters; "real, big, bustling alligators—"



"You're crazy," was all McWhinnie would say.

"I tell you I saw one this morning," continued Peters, emphatically. "It lay close inshore kicking up a deuce of a fuss in the water. It was in plain view for ten minutes or more, floundering about, lashing the water, and seemed to take refuge at last down there beside those logs on the far side of the storehouse."

"You're crazy!"

"I never saw such a big alligator as this one in all my days, and, believe me, I was as much surprised as you are disbelieving, which is saying a bit."

"You're crazy!"



AN "ALLIGATOR."

McWhinnie polished away at a twenty-two-bore rifle. We bought that rifle believing it would secure us food for the camp in the shape of rabbits and partridges, but soon found that at twenty yards' range it varied a good three feet, and the worst of it was that it seldom varied in the same direction. McWhinnie did not know this fact as yet, so polished industriously.

"It's all very fine for you to sit there and parrot

*Reprinted from the Wide World Magazine, of London, England, and being a part of Mr. Barr's amusing account of the trials and tribulations of three "tenderfeet" in the Great Canadian Wilderness. The author narrates the story of a dispute concerning an "Alligator" and how the party found themselves marooned. It has been ascertained that the "Alligator" referred to in the story, and of which an illustration is shown, was manufactured by Messrs. West & Peachey, the well-known manufacturers of alligators, Simcoe, Ont.

"You're crazy," but I want you to understand that I saw the alligator with my own eyes, and—"

"You're crazy!"

"But, McWhinnie," I put in, "there are alligators in these waters."

"You're crazy!"

So I shut up. Silence reigning for some time, McWhinnie condescended to break the blow by saying:—

"Yesterday's trying walk and driving rain have turned your heads. You're both crazy!"

The three of us sat in front of the log house on Douglas farm, Quinze lake, Quebec. Breakfast had been served at 5.30 a.m. sharp, and turning out at that we'd hurr to eat frit fried pork and apple pie gave our enthusiasm such a jar that we were now trying to recover equilibrium by taking matters easy for a few hours. Down on the foreshore our two guides were busy with their canoes. Each had his canoe wrong side up on wooden horses and tested every suspicious spot on the birch bark by putting his lips to it and sucking with all his might. If air came through, that spot was patched with steaming pine resin. Douglas farm is a patch of vivid green ringed round by a giant wall of woods, and before the door of the log house stretches Quinze lake, in shape almost circular; indeed, a mighty amphitheatre in the wooded highlands. This farm is planted there in the wilderness for the purpose of growing fodder to supply the lumbermen's camps of the district. It would be useless to raise anything else. Nothing could be got to the outside world from this isolated spot. Douglas farm is the farthest outpost of the bustling world that stands in that part of the globe, so far outside that the marchings and countermarchings of nations and people are heard of only at long intervals. For city-weary eyes no place could be more refreshing—the silent waters, the ghostly woods and the ineffable sweep of the sky. A sceptical soul must ever be horribly out of place in such a green spot as Douglas farm. Yet there one sat polishing a twenty-two-bore rifle.

We sat in silence some time before round the corner came the mistress of the house, a kindly, intelligent woman, busy with the onerous duties of the farm. Peters leaped to his feet.

there earlier this morning. I have been trying to get you into a proper frame of mind to take a photograph of the alligator, you being the man who best of all manages the camera."

McWhinnie, now vividly interested, dived into the house and reappeared with his camera.

"Steady on!" cautioned Peters. "Please do not burst upon the thing or you may stampede it. I am particularly anxious to secure a first-class photo of it to take back to London. Try to imagine that

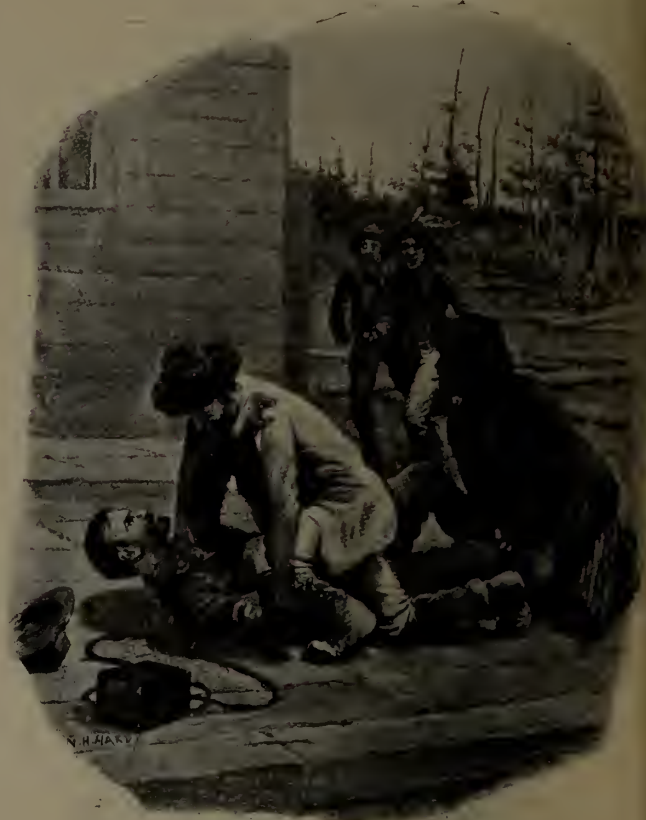

"LET ME UP AND I'LL DO FOR THE TWO OF YOU."

you are a Red Indian on the scout. Therefore, we'll go down Indian file; you first, Chronieler second, and I'll bring up the rear."

McWhinnie nervously fingered the camera.

"What range should I set the focus to?" he inquired, anxiously. "I must have a good snap of the brute!"

"One hundred feet should do nicely," Peters advised, in a hoarse whisper. "Make your way silently as a stalking cat, step quickly out, take as steady aim as circumstances allow, and you're sure of one good picture. The sun is where he should be and the air clear."

A small staging or wharf surrounded the storehouse, and towards this the three of us crept, McWhinnie leading with the camera hugged to his chest and its one eye ready to detect its prey at the first possible instant. I came next, and Peters, cautioning, "'Sh!" at the slightest sound either of us made, brought up the rear. We stole down the grassy slope, gingerly placed moccasined feet on the rough planks, and at length McWhinnie braced himself up, brushed the hair out of his eyes, and made a last survey of his camera.

At the moment he raised his right foot to step out Peters tripped over a loose plank, uttered an unearthly yell and fell flat upon the wharf. Without looking round McWhinnie sprang out into the sunshine and swept the foreshore of the lake in one lightning-like, comprehensive glance.

"There's no alligator here," he barked. "You're bawling has frightened the beast away, confound you!"

Peters was by his side in a flash.

"Not at all. There it is. Quick!"

"I don't see it! Where?"

"There—there—where I point. Can't you see it; plain as a pantechicon—"

"I only see that rickety steamboat."

Peters' tones were contemptuous.

"Steamboat! That's no steamboat—that's an alligator!"

McWhinnie dropped the body of his camera, re-

"Excuse me," he said, "but was not that an alligator I saw this morning in the lake the other side of the storehouse, there?"

"Oh, yes," she answered, pleasantly.

Peters waited to give McWhinnie the chance to say, "You're crazy," but, instead, the rifle polisher sat gazing in wonderment at the woman.

"Do you think it is there now?" asked Peters.

"I am sure it is," she replied.

"Thank you. I think we'd better photograph it."

Mrs. Johnston entered the house.

"You don't mean to tell me—" stammered McWhinnie.

"Of course I do, that's exactly what I do mean. There is a Canadian freshwater alligator lying in the water behind that storehouse, or, at least, it was

taining firm hold of the strap. He whirled on Peters and swung the instrument in one mighty sweep straight for the foeman's head. Peters was prepared and, skilled in Rugby football, tackled sudden and strong. Down the two went while I, throwing myself on the infuriated McWhinnie's feet, held on with the hug of a bear, at the same time calling with might and main for the guides. McWhinnie was barking: "Let me up and I'll do for the two of you," all the while fighting and heaving into mighty contortions, and Peters, every time he could get enough breath to articulate, interpolated: "I'll explain all, McWhinnie, when you are calm. I'll explain all."

"I don't want your explanations!"

"Help us to hold him for a minute; he's had a fit," said Peters to the guides. They joined in the melee, and we soon had the enraged McWhinnie spreadeagled on the wharf. Peters sat himself down on the helpless man's chest and began:

"Now, McWhinnie, you've flown off the handle again. That is an alligator."

"Get off me!"

"You adopted too narrow-minded a course. You set your mind on one sort of alligator only, and that the common insect one. Here I have shown you a unique creation only to be met with in this part of the world—"

"Let me up and I'll talk to you!"

"There rides the most wonderful steamer you have ever seen, and the name of its class is 'alligator.' There are quite a number in this vast region of bush, and they are all 'alligators.' They are the Canadian fresh-water alligators. Can you guess why they are so named?"

"Get off me and I'll—"

"They are called alligators because they can run on water or land indiscriminately. They are used to tow rafts of logs down these wilderness streams. The waterways here are rich in falls and chutes, up which, or down which, no craft can go. So when one of these falls is reached the tow steamer takes to the land and passes by the turbulent waters, entering the stream again when the rapids are passed. Isn't that ingenious and interesting?"

"I'd be more entertained if you would kindly get off my chest."

Then Peters' stood up, and McWhinnie slowly rolled over until his legs hung down from the wharf and his moccasins touched the water. There he sat and gazed at the alligator.

"Now, sir," said Peters, at last, "are you not glad you came? Will you take a photograph of an 'alligator' now?"

McWhinnie shook his head.

"Not to-day," he said. "I'll wait til I come back. I don't feel like snapping the thing now. Let's get away."

It befell, however, that at the very first portage we came to there was an "alligator" high and dry, snorting and scrambling its way overland. We saw it do the last hundred yards and enter the water at the foot of wild rapids. McWhinnie condescended to photograph it for us.

SOME REFLECTIONS FROM A TORONTO STANDPOINT.

BY H. C. SALMON.



H. C. SALMON.

IN looking back over a period of time contemporary with the issue of your valuable, and at all times interesting trade paper, so faithfully representing the lumber interests of this young and rapidly growing country, we are somewhat at a loss where to begin.

The names of firms in the trade, the prices, terms of purchase and sale,

transportation and freight rates, have all more or less changed during the last twenty-five years. Some firms that were the leaders in the trade in Toronto, of which only we are writing, have ceased to exist, and are not now represented by any members of the original

ceased), Cook & Leak, Bryce Bros., DeLaplante & Bowden, Salmon & Watson, Fox & Company, C. H. Edwards, J. C. Scott, Crone & Patton and Reid & Company, have all changed more or less. The only firms retaining their original style of name that we are aware of are John H. Eyer and J. B. Smith & Sons, though the well-remembered and much-respected head of the latter firm has, with individuals of other firms, passed to the "Beyond."

Among the mill men most largely known to Toronto dealers, the names of Hay & Patton, W. W. Belding, the genial Robert and his more sedate brother William Henry, have long ceased to solicit orders. Toner & Gregory, of Collingwood; D. Davidson, of Penetang; the Emery Lumber Company, of Midland, and other millmen who were prominent in those days as sellers do not figure in this market as they once did. Time does not seem to have made much change in some of the mill firms, unless it is to have extended and broadened their operations, as with the Georgian Bay Lumber Company, the Victoria Harbor Lumber Company, Mickle, Dymont & Son, R. Laidlaw & Company, the Imperial Lumber Company and some others.

Prices have wonderfully changed, as well as the style of putting the lumber on the market. It used to be Clear and Picks, Good Common, Common, Shipping Culls, and Mill Culls, anything of a lower grade not being worth the freight. Now it is No. 1 and 2 Cuts, No. 3 Cuts and Peeler, Mill Run, Mill Culls and Dead Culls—and they are dead—this last grade at present commanding a better price than a good Shipping Cull in the "not so long ago." We have in mind good wide Sidings at \$12 per M., good one and a half inch at \$14, and a good stock of 1½ and 2-inch Clear and Picks at \$16, all f.o.c. in Toronto; also 2x12 Joisting at \$11.50. Now these grades from Mill Culls up would range from \$11.50 per M., and in some cases even more, and all at point of shipment. The mill men in the old time were glad to quote prices f.o.c. in Toronto, now it is all f.o.c. at point of shipment, taking no chances as to freight rates.

The price of white pine has risen to such an extent that substitutes have been put on the market, spruce, balsam, tamarac, and now hemlock, the latter very largely taking the place of pine in the construction of dwelling houses.



MODERN CIRCULAR SAW MILL.

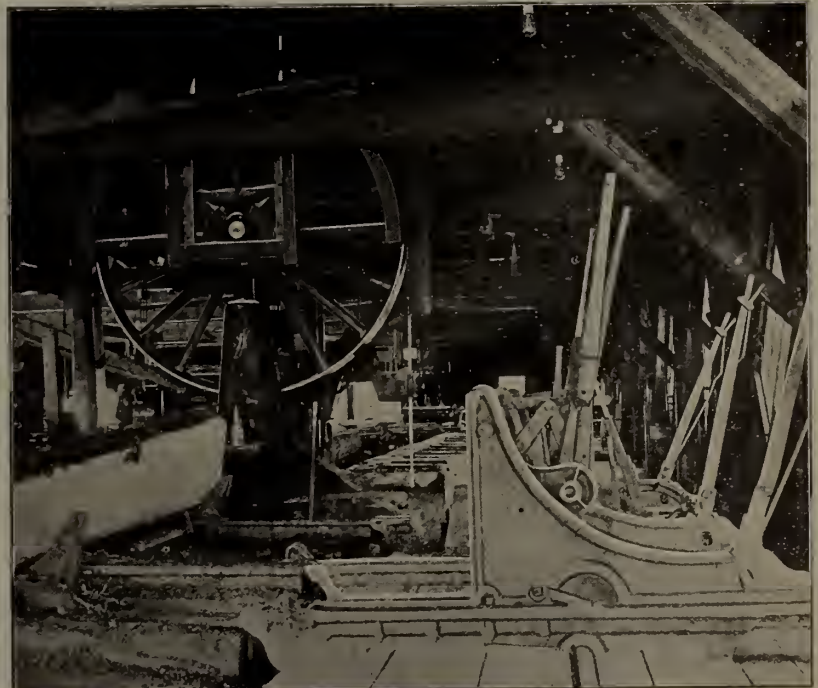

MODERN BAND SAW MILL.

From Bulletin, No. 31, Bureau of Forestry, U. S. Dept. of Agriculture

McWhinnie was growing calmer.

"I think a realization of the enormity of your conduct is beginning to dawn on you, and I'll soon shift my quarters. Let me tell you that the alligator is built like a scow, with runners on the hull, and that the paddle wheels you see, or will see when you get up, are used only to propel the boat when she is travelling alone. When hauling a raft on the water or herself over land, she does so by means of an anchor and one thousand feet of cable."

firms. Among these were Christie, Kerr & Company, S. C. Kanady, Oliver & McCracken, the Tenants, and others of lesser note. Other firms are still represented in the trade by some of its members under a different style of firm, of which we might mention Donogh & Oliver, George Gall and the Caldwells.

Among the yardmen such names as Greenless, Latch, Downey and Peter Scott are but memories. The firm of Hillock & Kent, Withrow & Hillock (both of the members of the latter firm being now de-

The Americans are placing large quantities of southern pine on this market, for use in large warehouses and other structures requiring timber of heavy section.

Someone always has lumber for sale; someone always wants to buy lumber. The "Wanted and For Sale" department of the WEEKLY LUMBERMAN is the medium by which many sellers and buyers are brought together. The cost of an advertisement, compared with the results, is very small.

BRITISH COLUMBIA SAW MILLS

Photographed and Described by Our Travelling Representative.

THE VICTORIA LUMBER AND MANUFACTURING COMPANY.

The Victoria Lumber and Manufacturing Company commenced operations at Chemainus fourteen years ago, by the purchase of the saw mill owned by Mr. H. Croft, which had a daily capacity of 40,000 feet of lumber. They operated the mill for one year, until their new mill was ready in 1891. The inauguration of the new mill, however, was not attended



SAW MILL OF THE VICTORIA LUMBER AND MANUFACTURING COMPANY, CHEMAINUS, B.C.

with the prosperity the company hoped for, and in June of the same year, owing to the overstocking of the market and the low prices obtainable for lumber, it was closed for a period of three and one-half years. Recommencing operations in the fall of 1894 the company's property has since experienced a period of remarkable development and prosperity, its capacity having been increased to such an extent that today the company occupies the proud position of being the largest lumber exporter in British Columbia.

Chemainus is situated on the east coast of Vancouver island, on a bay of about 300 acres of water area, which is called Horseshoe bay, with a good anchorage in from twenty fathoms at the entrance to five at the wharves. It is easy of access, yet sheltered from all winds, and with ample wharf accommodation, affords excellent shipping facilities, either by rail or water. It is about fifty miles from Victoria, B.C., on the Esquimalt and Nanaimo Railway.

The principal business of the company is export trade. Shipments are made principally to Australia, China, South America, Africa and the United Kingdom. Besides this vast export trade, the company are among the largest shippers east and into the great Northwest market.

To enable them to carry on such an immense business with a mill capable of producing 200,000 feet daily, together with a shingle mill with a capacity of 50,000 feet per day of 10 hours, the company have acquired over 122,000 acres of first-class fir, cedar and spruce, together with from thirty to forty acres of hemlock and white pine, while they have the assistance of over three hundred and fifty employees, with a pay roll amounting to the large sum of \$20,000 monthly.

The mill is 556 feet long by 84 feet wide, and at the front end extends 436 feet. The rear end is 92 feet wide and extends 108 feet. It is equipped with two Allis band saws, one Hill steam nigger, one Simond's log turner, one Wicks gang, two gang edgers, one pattern trimmer 50 feet long, one timber planer, capable of planing a stick 30 x 30 and 130 feet long, transfers for handling lumber, logs, live rollers for carrying lumber and slabs out of the mill, and a complete equipment of saw mill machinery, usually found in a well appointed mill.

Much care has been exercised in the construction of the boiler room, which is a separate stone building 64 feet square, containing fireproof doors. There are seven tubular boilers 66 x 16", two slide valve engines, 26 x 30, one upright engine 14 x 22 inches—used to operate the electric light plant—one twin slide valve engine 22 x 28, and an electric dynamo of 600 candle power. The planing room is 92 x 108 feet and has three planers, band re-saw machines,

gang edgers and cut-off saws. The lath mill has a capacity of 30,000 lath per day of 10 hours.

With such a vast amount of machinery to be kept in repair, the company very wisely constructed a machine shop adjoining the engine room 20 x 140 feet, fitting it up with large lathes, metal planers, bolt cutter, drill presser, hydraulic wheel presser, etc. A filing room is attached 20 x 140 feet, having automatic grinders and power rollers.

Nearly all the machinery in the mill was supplied

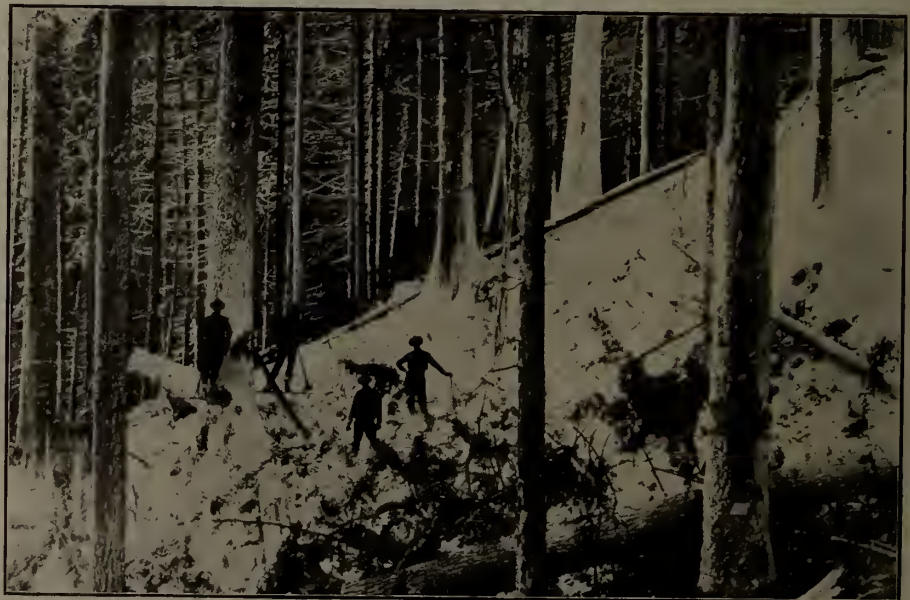

ON THE LIMITS OF THE CHEMAINUS LUMBER AND MANUFACTURING COMPANY, VANCOUVER ISLAND, B.C.

by the Wm. Hamilton Company, of Peterborough, Ont., through their Vancouver agency, while the Victoria Machinery Depot supplied three of the boilers.

The company possess five heavy locomotives, thirteen donkey engines, and have built a standard gauge railway for twelve miles to haul logs from the lumber camp to the mill. Hoists, weighing from 15 to 20 tons, are used in the woods to place logs in position and hoist them on the cars. The trees are cut with cross-cut saws up to lengths from 30 to 150

feet long, and hauled out by steam donkey engines. Arriving at the mill they are hauled up into the log slip by an endless chain with steel saddles. Some are cut up into timber by the band saw alone, others being cut into carts, carried over by the endless chain to the gang, and then cut into any size desired, from small timber to flooring. The lumber is carried on live rollers to the different patent trimmers and cut-off saws, the small timber going to the planing mill to be manufactured into siding, ship-laps, flooring, etc., the timber remaining being carried to the wharf which provides berths for seven ships.

The business is managed by Mr. E. J. Palmer, ably assisted by Mr. W. H. Phipps, the Secretary; the other officers being Mr. J. A. Humbird, President, and Mr. T. J. Humbird, Treasurer. They are represented by R. P. Rithet & Company, Victoria, B.C.; Welch & Co., Incorporated, San Francisco, and the Eddy Falk and American Trading Company in the Orient.

THE BRUNETTE SAW MILL COMPANY.

The accompanying illustration shows the mills of the Brunette Saw Mill Company, one of the oldest organizations in British Columbia. The mills are admirably situated on the Fraser river at Sapperton, and extend fully half a mile along the river front, giving employment to over two hundred persons and controlling the output of ten logging camps throughout the province.

The business was first established in 1878, a small mill being erected which was operated up to the year 1890, when a new mill was constructed. In 1895 the mills were completely destroyed by fire and from the ruins one of the finest and most complete establishments along the entire Pacific coast sprang up, this being the company's present property, minus the single mill, which they bought in May, 1903, from the Dominion Shingle Manufacturing Company, of Sapperton.

The plant consists of a saw mill, planing mill, shingle mill, dry kilns and a very large and well-equipped box factory. The saw mill is 350 feet long by 60 feet broad, and is equipped with one double circular saw, one circular saw and two edgers, with batteries for cutting inch lumber. The re-saw carriage is fitted with gun shot which enables it to cut lumber at a very high speed. Attached to the mill is the boiler house, which is built entirely of brick with iron roof, this roofing being a special feature

of all the buildings on the company's property. The driving power is supplied by a 300 horse power engine and six boilers 60 inches in diameter and 16 feet long. The entire equipment of both mill and boiler house, with the exception of the engine, was supplied by the Wm. Hamilton Manufacturing Company, of Peterborough, Ont.

The planing mill is 155 feet long by 80 feet wide, and is equipped with seven planers and matchers. The shingle mill is an entirely separate plant by

itself, situated 300 yards further up the Fraser river. This mill was first built for the purpose of cutting bolts, but a new addition was added for the cutting of logs in recent years, its dimensions to-day being 50 feet long by 70 feet broad. It is equipped with three of Johnson's upright shingle machines, manufactured in the local machine shops owned by Mr. Henry Schaaake. Power is supplied by one boiler, with Dutch oven, and one 50 horse power engine.

The capacity of the lumber mill is 100,000 feet per day and that of the shingle mill 100,000 shingles a day, most of this huge output being marketed in Manitoba and the Northwest Territories. The company, however, are developing a large trade in Ontario and Quebec, their red cedar shingles being in urgent demand even as far as Boston, Mass.

The box factory is considered the largest and best equipped in the province. It is an entirely separate



SOLCAN LAKE, B. C.

building, and is situated at the eastern extremity of the company's property. It is equipped with all the necessary trimmers and cut-off saws, three automatic nailing machines, one dove-tail and one setting-up machine and a two-colored printing machine. No other factory in British Columbia can claim possession of such a modern outfit. The majority of the machines were manufactured in St. Paul, Minn., by the Dove Tail Machine Company. The capacity of the factory is over 5,000 boxes a day, the company selling over 400,000 yearly to the salmon packing companies around the mouth of the Fraser river. Other shipments are made all through the province, fruit boxes finding a ready market in the Kootenays and the Okanagan territory.

The company have 35,000 acres of good fir, cedar and spruce where they keep a large force of men employed getting out logs. Three modern steam tugs, owned by the company, are kept constantly busy towing the logs to the mill.

The manager of the mill, Mr. L. A. Lewis, is a

man of great executive ability, and has been connected with the company since 1888, coming from Dresden, Ont., as cashier. That to-day he is manager is sufficient evidence of his energy and ability. He is ably assisted at the shingle mill by the brainy but quiet and unassuming J. Johnson, inventor of the Johnson shingle machine.

THE ONTARIO-SLOCAN LUMBER COMPANY.

The members of the Ontario-Slocan Lumber Company are all experienced lumbermen hailing from Orillia, Ont., the headquarters of the company. They are James B. Tudhope, M.P.P., president; Thomas Chew, vice-president; George Chew, general

power. A dry kiln, 30 x 100 feet, takes care of the output, which is from 60,000 to 75,000 per day; although the capacity, when running full time, is 125,000 per day. Ever since commencement of operations in 1903, the entire output has been sold in Ontario alone.

The company also operate a small saw mill at the head of the lake, with a capacity of 20,000 feet per day, the output going to supply the miners around at Three Forks, Sandon, etc., and the Northwest.

JAMES LEIGH & SONS.

The saw mill and sash and door factory of James Leigh & Sons, at Victoria, B.C., which was erected



SHINGLE MILL AND ENGINE ROOM, ONTARIO-SLOCAN LUMBER COMPANY.

manager, and J. H. Lavallee, secretary-treasurer.

The company's mills, which were only completed in 1903, are situated at Slocan City, at the foot of Slocan lake, about two hours' journey from Nelson. Slocan is a typical little mining town, and affords splendid opportunities to the mountain climber and lover of Nature to indulge his tastes with gratifying results, while Slocan lake offers the best of boating, bathing and fishing, the summer weather being delightful.

The plant consists of a single mill only, although it is probable that the company will erect a large lumber mill at a later date. The main building is 50 x 120 feet, and is equipped with three Letson-Burpee machines and one clipper. Two boilers and one engine of 60 horse power supply the motive

power. The mill is situated on an arm of Victoria harbor, about one and one-half miles from the famous Esquimalt naval station. It is one of the most up-to-date mills in the province.

The mill covers an area of three and one-half acres and commands a view of the famous Victoria Gorge on the north, and Rock bay to the south. The foundation of the main building and shingle mill is laid on a bed of solid rock, all necessity for bottom sills being thus obviated. The mill proper is 180 feet long by 60 feet broad. The sawing floor is equipped with one set of twin circular saws, a Waterous edger, the usual trimming saws and lath machinery, and all other accessories of a first-class plant. The capacity is 25,000 feet daily, and from five to six million a year.

The shingle mill is attached to the main building, and forms a good sized industry in itself, although—owing to the overstocking of the market—it is at present closed. The mill is equipped with a heavy log haul-up rig for bauling up the logs in the log end of the building, and one Perkin's machine, the capacity being 50,000 shingles in one day of ten hours.

More than ordinary care has been given to the boiler-house, non-combustible materials being used as far as it was possible in its construction. A battery of two boilers was installed, each with a capacity of 350 horse power. The mill is driven by three powerful steam engines, each with a capacity of 300 horse power.

The company cut all their own logs from timber limits leased on Nitenat Lake, V.I., and deal extensively in cedar, fir and spruce, shipping the finished product along with the product of their small sash and door factory by the C. P. R. boats to all parts of the Kootenay and local markets.

KEEP UP-TO-DATE.

Mr. James Arniel, Port Stanley, Ont., writes: "I herewith enclose you one dollar for the CANADA LUMBERMAN, as a person cannot keep up-to-date without being on the list of your subscribers."



SAW MILL OF THE BRUNETTE SAWMILL COMPANY, NEW WESTMINSTER, B. C.

THE Canada Lumberman

MONTHLY AND WEEKLY EDITIONS

PUBLISHED BY

The C. H. Mortimer Publishing Company
of Toronto, Limited,

CONFEDERATION LIFE BUILDING, TORONTO.

BRANCH OFFICES:

38 ALLIANCE BUILDING, MONTREAL.

UNION BANK BUILDING, WINNIPEG.

21 GREAT ST. HELENS, LONDON, E. C.

The LUMBERMAN Weekly Edition is published every Wednesday, and the Monthly Edition on the 1st day of every month.

TERMS OF SUBSCRIPTION:

One Copy, Weekly and Monthly, One Year, in advance, \$1.00
One Copy, Weekly and Monthly, Six Months, in advance, 50
Foreign Subscription, \$2.00 a Year.

ADVERTISING RATES ON APPLICATION.

THE CANADA LUMBERMAN is published in the interests of the lumber, wood-working and allied industries, being the only representative in Canada of these important interests. It aims at giving full and timely information on all subjects touching these interests, and invites free discussion by its readers.

Special pains are taken to secure for publication in the WEEKLY LUMBERMAN the latest and most trustworthy market quotations throughout the world, so as to afford to the trade at home and abroad information on which it can rely in its operations. Subscribers will find the small amount they pay for the CANADA LUMBERMAN quite insignificant as compared with its value to them. There is not an individual in the trade, or specially interested in it, who should not be on our list, thus obtaining the present benefit and aiding and encouraging us to render it even more complete.

OUR TWENTY-FIFTH YEAR.

A quarter of a century ago the value of lumber exported from Canada in one year was not more than \$10,000,000; to-day it is about three times that amount. In addition, a vastly increased quantity is consumed by our home industries and exported as manufactured product. In many other branches of industry the expansion has been equally great. No previous quarter-century witnessed such a development of our natural resources or such rapid strides along the path of commercial advancement.

That the trade journals have aided in this progress will, we think, be admitted. This Anniversary Number marks the twenty-fifth yearly milestone in the history of the CANADA LUMBERMAN. Something of interest may be found on every one of the 104 pages comprising this number. It has been the aim to contrast the conditions existing to-day in the lumber industry with those of twenty-five years ago, and to portray some of the more important changes and improvements which have taken place. We hope that our readers will consider that the ground has been covered in a satisfactory manner. If so, we shall feel repaid for the large amount of labor and expense involved in its preparation. Were it published solely for pecuniary gain, the result would not justify the effort. Of the items constituting the expense account, we might mention the cost of paper alone, which was upwards of \$400. We desire to offer our appreciation to the many contributors who have assisted us, as well as to the numerous advertisers who have extended their liberal support.

During the interval from 1880 to 1905 wonderful changes have taken place in the lumber field. Specialization has been and is the trend of the times. This can be no more strikingly illustrated than by referring to the first number of the CANADA LUMBERMAN, published in Peterboro, which contained two pages of lumber news and twelve pages of general reading, under such headings as "The Earth's Population," "The Sultan's Evil Genius," "Agricultural Notes," "Question of Higher Education," etc.

To-day the most successful trade journals are devoted strictly to the industry they represent and give the requisite information in as concise form as possible. The demand is for plain facts, tersely told.

We can speak with gratification of the lumber trade in the past. What has been accomplished for the development and improvement of the industry is doubtless much more than was anticipated at the beginning of the period under review and probably more than will be attained in the next twenty-five years, although we dare not predict of the future. The industry is on a better footing to-day than ever before—the ruthless destruction of the forest by fire is no longer permitted; instead of wantonly destroying the forests as in the earlier days, the public recognize the wisdom and necessity of preserving the timber; economical methods have been introduced into lumber manufacturing; the raw material furnished by our forests is each year being used to better advantage, and the country at large will eventually derive the greatest possible benefit from this national asset.

Canada has yet an immense quantity of timber, but it must be properly husbanded if we are to continue as a wood producing and exporting country. Happily, our Federal and Provincial Governments are fully alive to the situation and the next few years promise to see the adoption of some very effective plans for perpetuating the timber supply.

What influence of a beneficial character this journal has exerted upon the lumber trade can best be judged by others than ourselves. We are conscious of shortcomings, and if at times we have expressed views which have not commended themselves to our readers, it should be attributed to error of judgment to which all are susceptible. As regards the future, we will continue to strive to better the condition of the important industry which the journal represents and to merit the support of the trade. May 1905 be the forerunner of many years of prosperity and success for the lumber and allied interests.

JUSTICE IN EQUALITY.

The deplorable condition of the lumber and shingle industry of British Columbia ought to appeal to the Dominion Government in a manner that should bring some relief in the near future. Not only are many of the large mills closed down owing to the unfair conditions which exist, but a number of the smaller manufacturers have become bankrupt. To what extent the larger firms will be able to continue operations under such adverse influences will depend upon the condition of the United States lumber market. If the demand there should improve to an extent which will absorb the product of the mills and remove the slaughtering of lumber on the Canadian market, our manufacturers may again resume operations and be in a position to make a living profit. If the opposite condition should prevail, however, the only hope of a revival of the lumber industry of British Columbia lies in receiving some measure of protection from the hands of the Federal Government.

The lumbermen of Western Canada are ask-

ing no favors. They simply wish to be placed on an equal footing with other industries. The Canadian manufacturer of machinery is protected, by a duty, from American competition. The Canadian laborer and artisan is protected from competition by the Alien Labor Law. The Canadian manufacturer of lumber is not only unprotected, but he is also excluded from the United States market by a \$2 duty. Is it reasonable to suppose that under such unfair conditions the lumber trade can be developed as it should? Free trade may be a good thing. Protection may be a good thing. A policy which protects one industry and leaves another open to unscrupulous competition is assuredly unjust.

The Discriminating Customs Act, which prevents the American manufacturer from selling in Canada goods on which there is a duty any cheaper than they are sold for home consumption, cannot apply to lumber on account of the non-existence of an import duty, but this could be overcome, and very effectively too, if the Government so desired. The placing of a nominal duty, if only fifty cents a thousand, on American lumber, would render the Act effective and give the Canadian producer some measure of protection. Then, when it could be shown that lumber was being sold in Canada at less than a fair market value, it would be subject, in addition to the duty otherwise established, to a special duty equal to the difference between such fair market value and the selling price.

The Government has apparently feared the condemnation and criticism of the western consumer, but a moderate measure of relief such as above suggested would furnish little ground for adverse criticism.

A point which has not heretofore been mentioned is the effect of present conditions on the timber supply. The lumber manufacturer is face to face with the necessity of producing lumber at the smallest possible cost and sets himself to work to build a mill which will cut the maximum of lumber at the minimum expense. This he aims to accomplish without regard to the saving of timber. Such conditions will ultimately shorten the life of the timber supply, although temporarily meeting the exigencies of the situation.

A SIDE LINE FOR RETAILERS.

Where the volume of trade is sufficiently large, the retail dealer no doubt finds the most satisfaction in confining his business to lumber alone, but in many instances it is not only advisable but essential to have a combination yard in which is carried a stock of lumber, coal, and perhaps general building supplies. A side line which is now being handled by some dealers, and for which there is a rapidly growing demand, is cement blocks. Machines for manufacturing these blocks can be purchased at a small cost and the making of them is comparatively simple, so much so that they can be sold at a very reasonable price and still leave a good margin of profit for the manufacturer. Dealers who may not wish to purchase a manufacturing plant might find it an advantage to carry a stock of the blocks to supply the local requirements.

BAND VERSUS CIRCULAR.

OTTAWA, December 16, 1904.

Editor CANADA LUMBERMAN:

DEAR SIR,—In your issue of December, on page 13, I notice four diagrams, two of an 8" and two of a 6" log, sawn into boards of 1 1/16" thickness; Figs. 1 and 3 cut with a circular of 7 gauge, 1/4" kerf; Figs. 2 and 4 cut with a band saw, 16 gauge, 7/64" kerf.

From my experience in the manufacture of lumber from small logs, both with circular and band saws, also by previous making of diagrams, I was not satisfied that the amount of lumber claimed in the article for the band saw, as being obtained from a 6" or 8" log, was possible in practice. To be exact and find out just what a 6" or 8" log would make, of boards the proper or merchantable width and thickness, I constructed diagrams 1A, 2A, 3A, 4A, and 5A, which I submit for comparison with diagrams 1, 2, 3, and 4, as published in the article in question.

In Fig. 2A as contrasted with Fig. 2, it will be observed that the difference is in the two outer boards, the diagram Fig. 2 giving this board as 4 in., while it will be observed from the dotted line on Fig. 2A that it is impossible to obtain a merchantable 4 in. board, that is, a board 4 1/8 in. wide, free of wane. A width less than this could only be marketed as a 3 inch. Similarly, in Fig. 4A, which represents a 6 in. log, it will be observed in contrast with Fig. 4, that it is impossible to obtain a 4 in. board, three inches being the most obtainable in this case, as in Fig. 2A.

Comparing Fig. 5A with Fig. 4A, it will be seen that even with 1/4 in. kerf, the same amount of lumber can be obtained as with the thinner kerf.

Comparing Fig. 5A with Fig. 3, it will be observed that Fig. 3 does not represent the full amount that can be obtained from a 6 in. log, even with 1/4 in. kerf, Fig. 3 only giving a total of 14 inches, while Fig. 5A gives a total of 16 inches.

In submitting Figs. 1A and 3A for comparison with Figs. 2A and 4A, I wish to state that circular saws carrying this kerf, 3/16 in., have been in use during the last four seasons, sawing small logs, no saw in the mill using more than this. From these diagrams it will be seen that the same amount of lumber is obtained with both band and circular, the only difference apparently being a little larger slab with the band than the circular.

In reference to the different machines employed to manufacture lumber from logs. The old fashioned slabber and garr were in some points superior, and in designing new machines I think those points should be followed as closely as possible. For instance, in placing a log on the slabber referred to, the man stood at the end of the log facing the front of the saws, and could line the log evenly on both sides, the same as a man can a board on a double edger. The gang was the same (see sketch). But with the band or circular saw and carriage, the man who lines the log for the first cut stands to one side of the log (also see sketch), and although he may be very expert, he not being in line with the log or the

saw, can only place it at a venture, and when we figure the saving of modern fast cutting thin band saws, we should not lose sight of the fact that every log is placed or lined at a

men believe, and my experience in the mill doing the actual manufacture bears me out in this contention.

Although I differ with the Waterous Engine

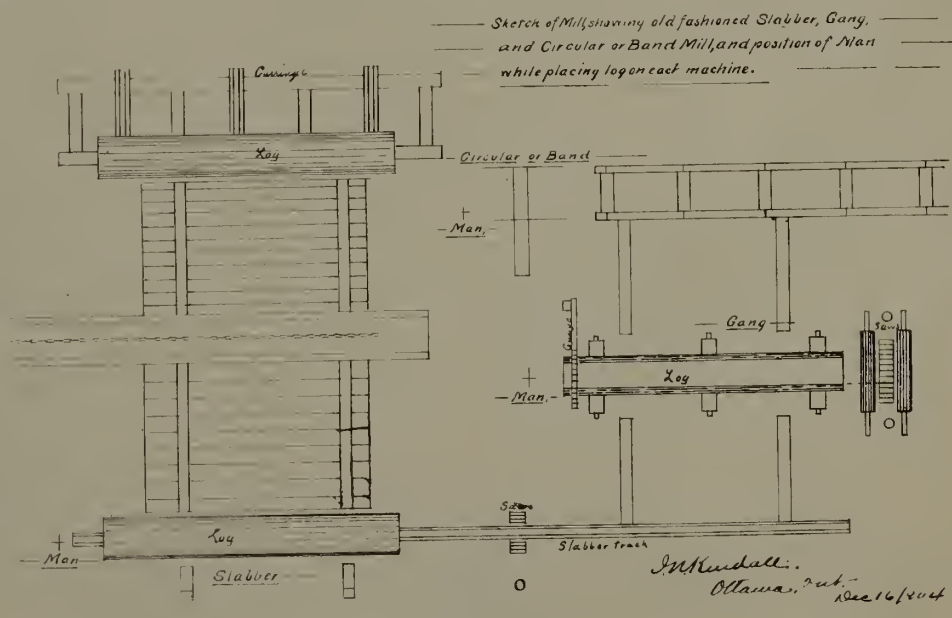
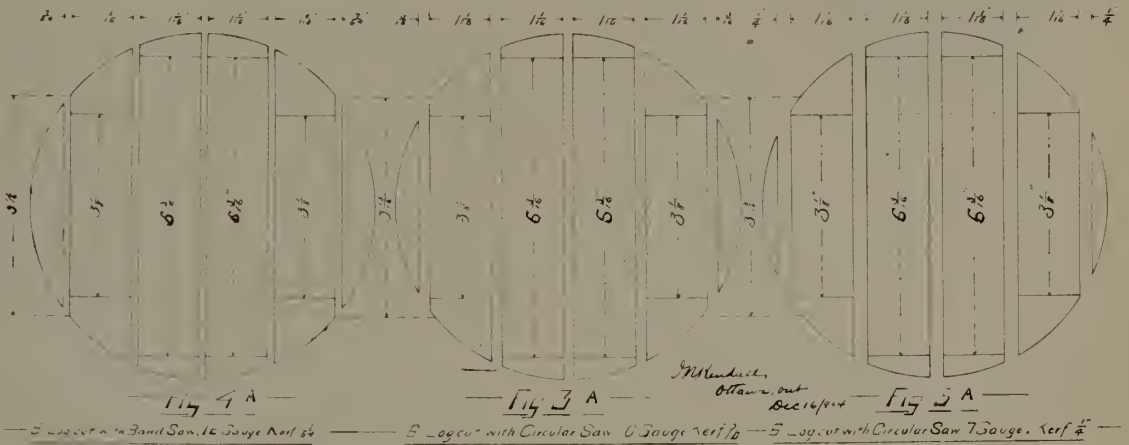
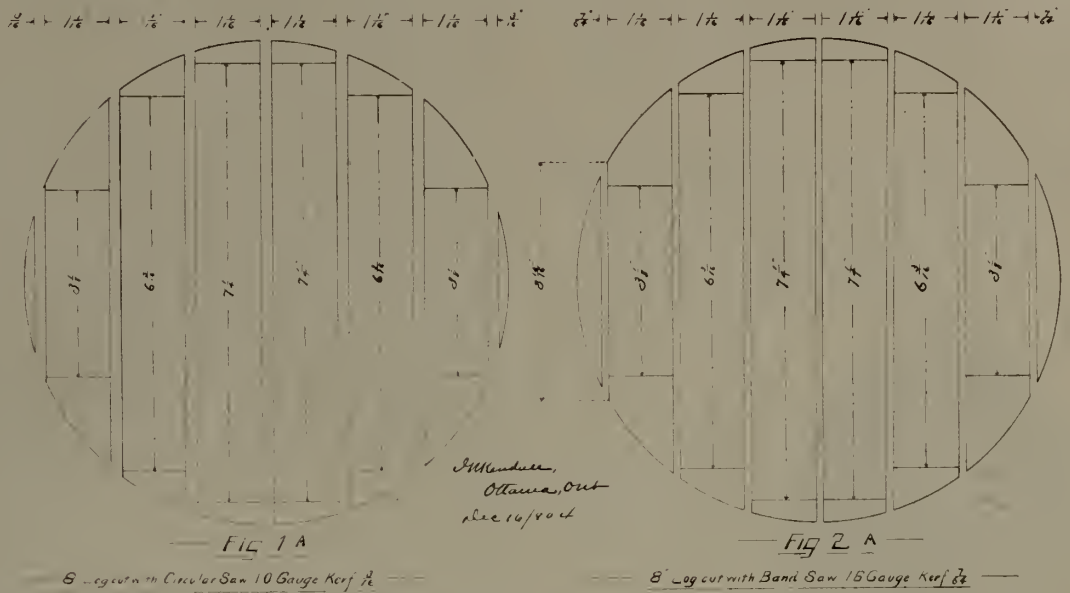

disadvantage, and often a large percentage of lumber is lost in this way.

I do not wish to be understood as maintaining that there is no saving in the use of thinner saws, particularly in the case of medium or large sized logs, but I contend that in the case of small logs such as those under discussion, the saving is not as great as many lumber-

Works Company as to the amount of saving by using thin saws in cutting small logs, I was much pleased with the article in question in your paper, and hope others will also feel interested enough to give their views on the subject.

Yours truly,
I. N. KENDALL.

THE Wood-Worker and Retailer

BUILDING AND EQUIPPING A PLANING MILL.

By DANIEL WILSON, Collingwood, Ont



DANIEL WILSON.

IT is understood that the term "planing mill" as applied in this case is a building where lumber is taken in and worked up into all kinds of dressed material that enters into the construction of a building. As conditions are not similar in all

instances, it is practically impossible to lay down definite plans that will work out satisfactorily in all cases, so we will confine ourselves to the general ideas which govern the majority of cases.

In the first place it is important to plan the building in such a way that if it is required to increase its capacity, it can be enlarged to advantage. This is very often overlooked and a building erected which is considered ample, but in a few years it is found that the business increased so much that more room is required. An addition is made which cannot be as convenient as desired, and very often it is necessary to keep on increasing until the whole plant is unhandy. Both on account of the cost of tearing down the old building and replacing it with one more suited to present requirements, as well as the stoppage of trade in the meantime, a great many carry on the business under great difficulties which could have been avoided in a large measure if the original building had been carefully thought out.

There are a great many points which must be kept in sight. It is advisable to have a fairly high ceiling to get the shafting well up out of the way and a good length of belt to each machine, as well as to have plenty of room for the shaving exhaust system. If possible place the engine and shafting so that the belts to the principal machines at least and the main driving belt will run with the slack side on top and the draw on the bottom, which allows the belts to be run much slacker and gives a better lap on the pulleys. The building should be not less than 70 feet wide from front to rear (80 feet is better), with the bottom floor low enough and the doors large enough to permit the load being driven right inside and placed where it is the most convenient,

with the least possible handling. Where the lumber has to be handed in through the doors it costs more, and it is practically impossible to keep the lower flat warm in cold weather, and when the machinery is cold, it works stiff, takes more power to drive it, and will not do as good work. The men are obliged to wear more clothes and some kind of covering on the hands to keep warm; they cannot set up the machine nearly as quickly, consequently while the machinery costs more to run, you cannot get either the quantity or quality of work done in the same time that can be obtained if the building is warm. In addition, the danger of operating is much greater. A man is much more liable to injure himself or the machine when he is handling a wrench with numb fingers making necessary adjustments. Standing operating a machine on a cold day with the doors open is a cold proposition. By driving the load inside, the doors can be kept closed except when the loads are passing in or out, which is a decided improvement, even if the lower flat is not heated.

Another very important consideration is to have plenty of light. It is impossible to have too much light and it is advisable to have as much as possible. Keeping the interior well whitewashed is an expenditure that pays. It is not possible to get the same amount of work done in a badly lighted shop with low ceilings and dark walls that will be done with the same men in a shop with ceilings of good height, plenty of light and white interior. On a dark, dull day the dark shop has a depressing effect on the workmen and almost unconsciously they get into a listless way of working that is hard to shake off. On the other hand, a bright shop has an exhilarating effect which shows itself in the amount of work done; besides there is the extra cost of lighting up morning and evening during the short days.

The placing of the machines is a very important part. Every move that can be cut off in operating reduces the cost of production. The relation of one machine to the other must be carefully considered. Have them placed, whenever it is possible, so that when the work comes from one machine it is right to hand for the next one. A good way to lay out the machines is to take each floor and lay it out to a scale, mark the shafting, hangers, couplings, pulleys, posts and all other obstructions, then take a piece of cardboard and lay out the size of each machine to a scale, cut them out and write the name on each one, then place them on the floor plan and keep shifting them around until you get each of them in the

most convenient place possible to get the best results in operating. It may take several hours of careful study to get them all arranged satisfactorily, but you will find it a splendid investment, as well as a most fascinating proposition, particularly among the smaller machines which are usually placed on the second floor. Have them all placed convenient to each other, where one operator will not interfere with the other, and where you can get the driving pulley on the shaft, and a place for the countershaft with a belt not too long nor too short for each. Then pencil around each piece of cardboard and write the name of the machine it represents on the squares they made on the floor plan, and the machines can be placed in a short time, the work having been drawn to a scale, and having all the measurements on the floor plan.

The next thing is belts. On wood-working machines they nearly all run fast over small pulleys, and the best belts are the cheapest in the end. Leather belts as wide as the pulley will take are the most suitable, and for the driving belts on the heavy machines at least, "double extra" gives the best results. Belts are not used for ornamentation, and men are not hired to run the machines for the purpose of giving them employment, but for the purpose of turning out the material. It is very short-sighted to equip a machine with narrow, light belts of inferior grade which run off or break when a thick or tough piece goes in. The time lost by the machine and operator in humoring or fixing poor belts will very soon pay the cost of a good one. In building and equipping a planing mill, carefully thought-out plans beforehand means dollars saved in operating.

ARRANGEMENT OF A MODERN WOOD-WORKING PLANT.

Our readers will no doubt be interested in the following description and accompanying plans of the wood-working plant of Chappell Bros. & Company, Limited, at Sydney, N. S.

Beginning at the basement, which is 7 feet deep and laid off as shown, the storage room is used to keep such stock as is to be seasoned slowly. Next is the fuel room to which the refuse from the machines finds its way—from those on the first floor, through openings in the floor, and from the second floor, through conductors. Coal is also admitted to the fuel room through the back windows.

No. 1 on the plan is a 75 h. p. boiler, the boiler room being a brick vault with a sheet iron ceiling, and the doors are covered with



WOOD-WORKING FACTORY OF CHAPPELL BROS. & COMPANY, SYDNEY, N. S.

sheet iron. This ceiling is 14 feet high and, as shown, rises 7 feet above the first floor, and the space above it to the second floor, which is always dry and warm, is found very useful. The blow off from the boiler runs to outside of wall and no trouble is experienced from escaping steam.

No. 2 is a 60 h. p. high speed engine. No. 3 is a dynamo, from which the entire plant is lighted.

The proposed machine shop is a secondary consideration from the original plan, and is now useful as a store room for all odds and ends connected with the machinery, and as a general workshop for the engineer and his assistants.

Coming to the first floor we begin with No. 4, a large planer and matcher with drop heads that make it convenient as a surfacer. No. 5 is a buzz planer, used for truing up stock that may need to be so treated before it goes to the ripping saw or moulders. No. 6 is a rotary saw with carriage, for squaring up posts, heavy ripping, and for truing up edges of boards and planks that may be sprung edgewise. No. 7 is a rip saw with variable self feed. This machine carries any reasonable number of saws and is one of the most useful tools in the plant.

No. 8 is a swing cross cut saw. Next in order is No. 9, a large endless bed, 12 in., four-sided, outside moulder, and is used for planing, moulding, matching, sticking gutter, etc. No. 10 is an emery stand, carrying a number of wheels for general grinding. No. 11 shows the position of a rapid, endless bed planer, used for general planing. No. 12 is a light 6 in. four-sided moulder, on which the lighter mouldings are stuck and the finer sheathings made. No. 13 is a cut off saw. This saw is stationary, with rolling table, at a height to properly make the cross cut for the horn on window sill. The cut lengthwise is also made on this saw.

No. 14 is a window frame machine with dado head, pocket and pulley cutting attachments. It is a very useful machine for frame making. No. 15 is a 24 in. drum sander. No. 16 shows the situation of a band re-saw. While it has its inconveniences because of lack of space for piling at either front or back, the

reader will notice its position makes it convenient to receive stock either from the kiln tracks or from yard by door at front of stairs

On the second floor we begin with a variety moulder, No. 17. No. 18 is a jig or scroll saw, No. 19 a four sided sash sticker and moulder, No. 20 a light ripping saw, No. 21 a 24 in. surfacer, No. 22 a variety saw table, No. 23 a buzz planer, No. 24 a patent adjustable

This completes the list of machines and tools, except an emery stand on a platform suspended from ceiling over the centre of the first floor. From this position the foreman of the first floor, who does the filing and grinding, can work and at the same time keep an eye on what is going on around him.

A glance at the first floor plan will show that proper sanitary arrangements have been considered. There is a drinking fountain on each floor for the convenience of the employees, and also hose connections with the city water supply for fire protection.

On the second floor plan will be noticed a large space at the head of the stairs, clear of posts or other obstructions. The idea of this is to have a place where large circles, arches or any large work may be done and fitted together.

On the back side of the shop near the glue room will be noticed a large bench. By removing a part of the top marked X, a sash laying out and marking device is exposed, which is simple in construction and a great time saver over other methods generally employed.

The plan shows glue room enclosed by partition. This partition is hung to ceiling in three sections, by strong hinges, and is easily hauled up by means of ropes and blocks with which it is provided, and the glue room can then be thrown entirely open to the shop if so desired.

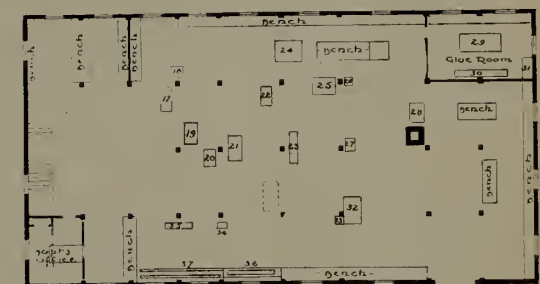
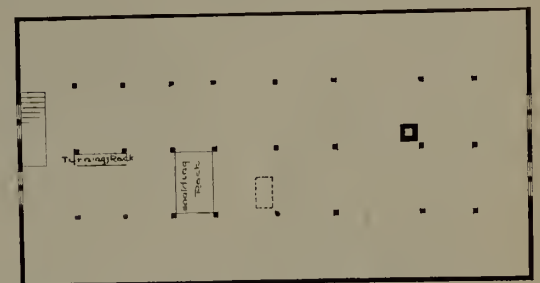
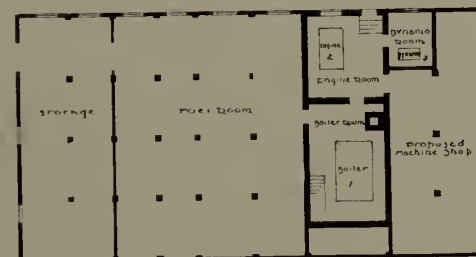
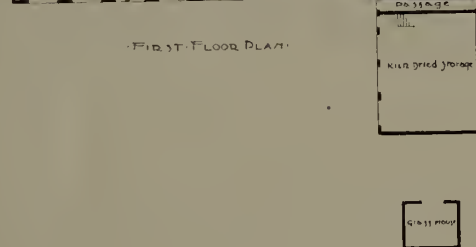

PLANS OF CHAPPELL BROS. & COMPANY'S WOOD-WORKING FACTORY.

sash clamp, No. 25 a tenoning machine, No. 26 a mortiser, No. 27 a dado and grooving machine, No. 28 a band saw, No. 29 a heavy door clamp, No. 30 a veneer press, No. 31 a glue boiler, No. 32 an arm sander, No. 33 a post boring machine, No. 34 a set of emery wheels, No. 35 a light turning lathe, No. 36 a medium weight and No. 37 a strong turning lathe for long, heavy work.

The dotted lines on second and third floors show openings that were intended for an elevator, but the elevator idea has been abandoned. A platform the size of the opening has been hung 6 feet 6 inches from the first floor, and the stock cutter at swing cut off saw can easily toss light material to this platform, from where it is again tossed to second floor by an apprentice.

Another glance at the first floor plan shows to the wood-worker the method of handling lumber through the kiln; but to make it easily understood we may say that the lumber is loaded on what is known as a transfer trolley on the loading platform at the rear end of building, and pushed into the kiln endwise. The transfer trolley is then pushed off the rails in the kiln and is from day to day passed through the kiln until it again lands on the transfer trolley and is run out to the machine where it is required, or stopped just outside the kiln and stored in the K. D. storage room. Three men can handle these trolleys with 2000 feet of lumber on them.

Regarding the heating of the kiln. The centre of the floor between rails is 12 inches lower than the floor level. Wood blocks from 6 inches to 18 inches long are placed on it and on these blocks rest pieces of pipe crosswise; on these pieces is laid a coil of 4000 feet of $1\frac{1}{4}$ in. pipe with two headers at one end and return elbows at the other. The wood blocks are so placed to give the pipes a drainage, and thereby no condensation remains in them.

Through these pipes all the exhaust steam from the engine passes. In addition to this there is a coil of pipe and a fan in top of the engine room, over part of boiler room. This coil is supplied with live steam from the boiler and the hot dry air is driven through sheet iron pipes into the hollow wall of kiln, the ends of these pipes being so turned as to drive the air down to a position from which it must rise between the pipes through which the exhaust steam is passing. This forces the circulation, and the walls, ceiling and floor being hollow, and double boarded with paper between, except 10 feet opening in top floor and lower ceiling, the hot air must naturally rise through the lumber and return by the hollow wall to be reheated and to mix with the dry hot air that is being forced in from the coil outside.

Having shown that the air in the kiln is continually rising through the lumber and returning by way of hollow wall, it is well to mention that one outside wall of the kiln is covered with copper only. This copper being cool acts as a condenser, and the dampness in the kiln adheres to it and the water runs down and drops off outside the building. Another good feature is that all air being forced in by a fan from hot coil, it is between the middle and outlet end, and there being a number of ventilators in the inlet end, the dampness coming from the newly admitted lumber cannot reach the lumber at or near the outlet end, but is forced through the ventilators. The use of this system allows lumber to be taken from the kiln every day and a like quantity admitted. The advantages of this will be readily seen by practical wood-workers.

A look at the illustration shows a large warehouse immediately behind the factory. In this is stored the product of the moulding machines. In the corner of the yard is a forge and a hose house, where a hose reel and 400 feet of hose are kept. Under the platform leading to the painting and glazing shop is a small house where glass is stored.

On part of the first floor of the building near

the railway, are the general offices. On the second floor is situated the drafting department, the remainder of the building being used as warerooms.

The paint shop and second floor of the factory are heated by steam, with return to boiler. The first floor is heated by steam, but being too low to return to boiler, a steam strap is used, and the outlet from it being attached to a soil pipe near the w. c., has the effect of keeping the w. c. free from frost even during the coldest weather.

In addition to this general steam heating system is a hot air blast, which is found useful in very cold weather, the pipes being so arranged that hot air can be forced to any part of the shop or centred upon certain machines, if required.

This model plant was designed by and constructed under the supervision of the general manager of the company.

AN IMPROVED SWAGE SHAPER.

The Pribnow swage shaper, recently greatly improved in design and utility, has, it is claimed, incorporated in its make-up the combined advantage of the fifteen years' practical experience of its inventor and of suggestions from many of the best filers in the country. The combination of the convenient and accurate adjustments between the adjustable clamping or shaping jaws 9 and 10, the adjustable tooth gage 4 and adjustable back guide 15, is the feature which makes the tool indispensable to the modern mill man or saw filer.

The clamping or shaping jaws 9 and 10 are made of the finest tool steel and tempered by a special process which makes the working parts very hard, fit to cut glass, but still they will not chip nor break. The forward end of the clamping jaws is beveled and comes in contact with the saw tooth in such shape that it forms a perfect chisel point, a perfect clearance, and widest at the extreme point. The clamping jaws clamp the tooth the entire length, which action supports the shaper in line with the saw and assures accurate shaping of the swaged points. It is essential to have the swaged points line up evenly on both sides of the saw to assure a straight cutting saw, this defect being most noticeable on double edge band saws.

After the shaper is placed on the saw and a test shows that the teeth do not line up evenly on both sides, if the points line too heavily on the left side the clamping jaw 10 is moved ahead by adjusting setscrew 14; if the points line too heavily on the right side of the saw the clamping jaw 10 is let back by setscrew 14 till the points average even on both sides of the saw. A novel feature of tooth gage 4 and adjusting screw 6 and adjustable tooth gage holder play an important part in this act.

The tooth gage 4 bears the same number on the end as the gage of the saw operated on. This tooth gage is a small round bar made of tool steel, the working end being accurately fitted to a standard form to straddle the swaged point, and the sides have the exact form of a finished tooth. A system is adopted so that each tooth gage is marked on its end with the gage of saw it is intended for, so that if a proper gage shall be used for the saw in hand the best results will be obtained. For illustration, a No. 16 will work on a 16-gage saw, but a No. 10 will not work on a 16-gage saw.

To adjust the tooth gage, if the finished point shall be too wide loosen setscrew 8 and turn thumbscrew 6 to the right; if the finished point be too narrow turn the thumbscrew to the left, and so on until the point is just right; then tighten setscrew 8. Another simple and valuable adjustment of the tooth gage in relation to the clamping jaws is embodied in the adjustable tooth gage holder. As a rule, on band saws the holder is left up, as shown in second illustration, but a slight movement down will bring the tooth in contact with a new wearing face of the clamping jaws and not change the gage of the finished point; in

other words, on circular saws it is convenient to adjust the shaping jaws to a different pitch in relation to the tooth and in connection with the adjustable back guide 15. The sectional cut shows a No. 5 shaper mounted on a large circular saw. The second cut shows the same shaper mounted on a common band saw.

As a rule, the back guide is long enough to cover two teeth besides the tooth operated on. If this back

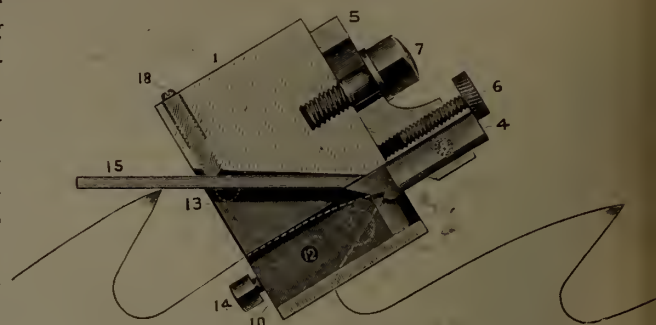

SECTIONAL VIEW, SHOWING TOOTH IN POSITION.

guide (15) shall be adjusted so that the inner point is in touch with the point of tooth gage 4 the shaper will slide along easily on the saw and can be operated with one hand and does not need a handle to steady it on the saw, although there is a handle on the opposite side from the clamping lever 2 for the convenience of the operator. Back guide 15 is adjusted by adjusting screw 18 and held in place by setscrew 13, so the shaper works equally as well on a circular saw as on band and gang saws; no matter what diameter or width the saws may be nor how far between points, with the handy adjusting screw 18 the shaper can be tilted to suit any pitch of tooth.

Grinding gage 16 (also shown complete in larger illustration) is furnished with each shaper. The clamping jaws are placed in it as shown at 17, and thus accurately ground and always kept smooth. The clamp-

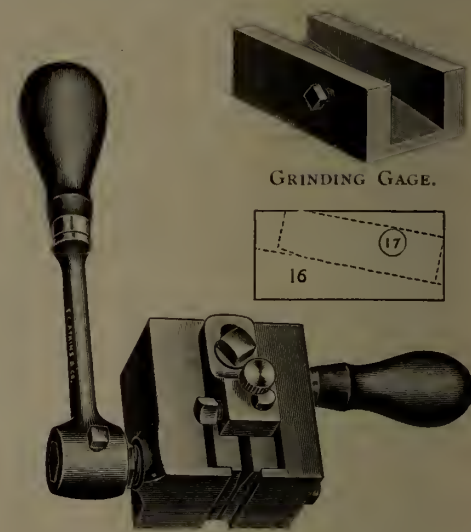

THE IMPROVED SHAPER.

ing jaws are reversible so that all four corners can be brought into use.

This tool is made in three sizes, for saws ranging from 6 to 24 gage, by E. C. Atkins & Company, Indianapolis, Ind., makers of saws and saw tools, whose Canadian office is at 30 Front street east, Toronto.

Do you read the "Wanted and For Sale" Department of the WEEKLY LUMBERMAN regularly? If not, you may be missing many opportunities if you have for sale or wish to buy timber limits, lumber, second-hand machinery, or, in fact, anything pertaining to the lumber business.

Plain oak, red or white, holds the center and front of the lumber stage at the moment. It brings as high a figure to-day as it ever did, and yet it sells within a few dollars of as low as its lowest mark. Certainly the great lumber trust has been very kind to the users of plain oak. There is a beauty to plain oak, particularly under stain, that is being recognized as never before.—Lumberman's Review.

THE STUART MACHINERY COMPANY.

Our Winnipeg representative was recently handed a group photograph of the operating staff of the Stuart Machinery Company, Limited, of that city, which we reproduce on this page, and which serves to illustrate the careful and liberal organization which is necessary with large western firms in order to reach and insure prompt service to the extensive trade catered to. The photograph represents only heads of departments, their total employees numbering over fifty.

The Stuart Machinery Company make a specialty of saw mill and wood-working machinery, and are west-

The Stuart Machinery Company's offices, warehouses and shops are situated directly over the new subway, two doors north of the C.P.R. tracks on Main street. They are a strictly up-to-date firm and are meeting with generous success in the machinery business of the West.

MOREAU'S PULPWOOD BARKING MACHINE;

On page 7 of this issue appears the advertisement of a machine which ought to interest every person connected with the barking of pulp-wood. It is the invention of Mr. Joseph Moreau, and associated with him

16 per cent. on any properly handled Moreau machine and ordinary size and quality of wood. Slipped wood (peeled in the sap) shows a loss between 13 1/2 to 14 per cent., and as in slipped wood only the bark is removed, all knots remaining, consequently the Moreau machine compares very favorably with slipped wood as to loss.

The selling agent, Mr. R. S. P. Smyth, an experienced lumberman, is firmly convinced that the Moreau machine is the very best invention on the market for barking pulp-wood. He expects to have one of them working on his property at St. Julie, P. Q., in a few

THE STUART MACHINERY CO., LTD.

ESTABLISHED 1878 INCORPORATED 1900

764 & 766 MAIN ST., WINNIPEG, MAN.

STOVEL CO

Staff members shown include: S. J. Ambro, Sr., Mechanical Engineer; J. L. Pollock, Chief Salesman; R. H. Mainer, Accountant; W. A. McLeod, Managing Director; R. H. Stuart, Jr., Electrical Dept.; Miss L. VanCamp, Stenographer; Jas. Moiland, Foreman Electrician; Robert McKenna, Foreman Machine Shop; Albert Watts, Foreman Boiler; David Thompson, Shipping Clerk; and W. E. Sutherland, Bookkeeper.

ern agents for The MacGregor-Gourlay Company, of Galt; E. Long Mfg. Company, of Orillia; Wm. Hamilton Mfg. Company, of Peterboro, Ont.; The DeLoach Mill Mfg. Company, of Atlanta, Ga.; Wm. Hill Company, of Kalamazoo, Mich.; The New Britain Machine Works, of New Britain, Conn., and others. They carry a complete stock of saw mills with capacities from 5,000 feet to 40,000 feet per day, also shingle machines, lath machines, two and three saw edgers, log jacks, jack chains and sprockets, and a large assortment of wood-working machines. In addition to the mill machinery, they also carry a stock of engines, boilers, pumps, shafting, hangers, Dodge wood split pulleys, leather and rubber belting, saws, emery wheels, etc.

are some mill-owners forming the Moreau Barking Machine Company, Limited, with head office in Montreal. Only recently has the machine been completed and put on the market, but nevertheless the company and the selling agent have had numerous inquiries in regard to it.

Two machines are now running on frozen wood, and are giving good satisfaction. Whenever a machine in operation has been watched closely by a practical man, that man has been convinced it is alright and justifies every claim made for it. The machine is particularly adapted to barking wood in 4 feet lengths, and is warranted by the inventor and his company to do it neatly, economically and fast. The loss is about

days, where he says "everybody will be heartily welcome to go and watch results."

L. Dunham has purchased Mr. Running's saw mill at Frankville, Ont.

The B. Greening Wire Company, of Hamilton, have issued their 1905 Wire Rope Catalogue. It contains illustrations and prices of every kind of wire rope, as well as tables of proper sizes of sheaves or wheels to be used to obtain the best results and tables showing the relative effect of various size sheaves on the life of the rope. Breaking strains and proper working loads in all cases are also given.

Uncle Sam would not allow his battleships to be babbitted with inferior babbitt metal. New Battleship "Nebraska" is lined with Syracuse Babbitt. Always specify best. It is cheapest in long run.

SYRACUSE SMELTING WORKS
MONTREAL NEW YORK SEATTLE

...BUCKEYE SAW M'FG. CO...

MANUFACTURERS OF
High-Grade Saws

Quick and careful work on Repairing.
All kinds of Mill Supplies.

REYNOLDS BROS., Proprietors
267 N. Water Street, COLUMBUS OHIO

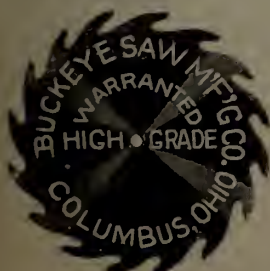

CANADIAN OIL CO. LIMITED
STRACHAN AVENUE TORONTO, ONT.
TO LUMBERMEN THE DOMINION OVER:
OUR TRADE WITH SAW-MILLS

Has been large and satisfactory. We again solicit your orders for the season of 1905.

Our agents will call with "STERLING"

Cylinder, Engine, Dynamo, Machine, and SPECIALTY Oils, Greases, Packing, Waste, Babbitt Metal, Ready Mixed House Paints, Varnish, Red and Black Roof Paint, Smoke Stack Black for Boiler Fronts and Saw Mill Refuse Burners, White Lead, etc.

BRANCHES: Petrolia, Ont. Hamilton, Ont. Montreal, P. Q. Vancouver, B.C.
London, Ont. "Soo," Ont. Winnipeg, Man. St. John, N. B.
Halifax, N. S.

'STERLING'
OIL

'STERLING'
OIL

A NEW USE FOR EXCELSIOR.

The by-product of almost every veneer mill is excelsior, and some of our friends in the business have expressed themselves as being at a loss to find a market for the commodity. The well known consumers, such as furniture factories and dealers, the dealers in cabinet hardware, druggists' sundries, and the whole range of the glass industries, are already well taken care of, and in nearly every case have contracts covering all the probable demand they will have in the regular conduct of their affairs. Yet there seems to be more excelsior still to be provided for.

Now arises a new use that has come to our notice recently. The cut stone people, as well as the shippers of monuments, have begun to use excelsior in large quantities for padding the expensive designs for shipment. One expensively carved capital from the Bedford stone district of Indiana, when crated and carefully stuffed for shipment, consumes something like a quarter of a bale of excelsior. It is easy to see just what large quantities would thus be called for in shipping all of the detailed parts of a great building operation which, in some cases, requires hundreds of cars of this precious building material.

True, the excelsior at times is likely to take fire by spontaneous combustion in hot, dry weather, causing a discoloration to the stone which is often hard to remove. Nevertheless, cut stone contractors have come to be large users of excelsior, and some of our friends will no doubt find an outlet in this direction for the by-product which has caused them some trouble to realize upon heretofore.

We might mention also the wholesale liquor dealers, who pack bottles of liquor into slack flour barrels and market them as a barrel of bottles. These parties are using more excelsior from year to year—quite probably showing an increase of 100 per cent. in the last year.—Barrel and Box.

DO YOU USE

ANY OF THE FOLLOWING IN OR ABOUT YOUR

Shipping Room or Factory?

A	Carpet Trucks	Hammer Nail	Needles, Packing	Shingling Hatchets
Adzes, Coopers'	Chisels, Box	Hand Saws	O	Shovels
Ash Cans	“ Fitmer	“ Screws	Openers, Crate	Spofford's Braces.
Auger Bits	“ Ripping	Handles, Mop	Oval Mallets	Sprinklers
Axes, Fire	Clamps, Cabinet	Hatchets, Barrel	P	Square Mallets
B	“ Carpenter's	“ Claw	Packing Needles	Squares, Carpenters'
Back Saws	“ Iron	“ Shingling	Pails, Fibre	“ Try
Barber's Braces	“ Piano	Hooks, Box	Pencils, Carpenters'	Steel Clamps
Barrel Hatchets	Claw Hammers	“ Fire	“ Lumber	Stencil Brushes
Bench Dusters	“ Hatchets	I	Pipe Wrenches	“ Ink
“ Rules	Compass Saws	Ink, Stencil	Plates, Stencil	“ Machine, Bradley
Bits, Auger	Coopers' Adzes	Iron Clamps	Pots, Marking	“ Plates
“ Expansion	“ Drivers	K	Pullers, Nail	Sticks, Yard
“ Screwdriver	Cotton Mcps	Keyhole Saws	R	Store Trucks
Blades, Saw, Turning	Crate Openers	Knives, Drawing	Ring Mallets	Strapping, Box
Blind Man's Rules	Crayons, Marking	L	Ripping Chisels	T
Box Chisels	Cut Nails	Lanterns	Round Mallets	Tailors' Shears
“ Hooks	D	Lumber Pencils	Rules, Bench	Trucks, Box
“ Scrapers	Dividers, Winged	M	“ Blind Man's	“ Carpet
“ Strapping	Drawing Knives	Machine, Stencil, Bradley	“ Boxwood	“ Factory
“ Trucks	Drivers, Coopers'	Mallets, Oval	S	“ Store
Boxes, Mitre	Dusters, Bench	“ Ring	Saw Blades, Turning	“ Warehouse
Boxing Hammers	E	“ Round	“ Frames, Hack	Try Squares
Boxwood Rules	Expansive Bits	“ Square	Saws, Back	Turning Saw Blades
Braces, Barber's	F	Marking Brushes	“ Compass	“ Saws
“ Spofford's	Factory Trucks	“ Crayons	“ Hack	Twines
Brackets, Fire Axe	Fibre Pails	“ Pots	“ Hand	W
Bradley Stencil Machine	Fire Axes	Mitre Boxes	“ Keyhold	Warehouse Trucks
Brushes, Marking	Fire Axe Brackets	Mop Handles	“ Turning	Water Buckets
“ Stencil	“ Hooks	“ Wringers	Scoops	Winged Dividers
Buckets, Water	Firmer Chisels	Mops, Cotton	Scrapers, Box	Wire Nails
C	Frames, Hack Saw	N	Screws, Hand	Wooden Clamps
Cans, Ash	H	Nail Hammers	Screwdriver Bits	Wrenches
Carpenters' Clamps	Hack Saw Frames	“ Pullers	Screwdrivers	“ Pipe
“ Pencils	Hammers, Boxing	Nails	Shears, Carpet	Wringers, Mop
“ Squares	“ Claw		“ Tailors'	Y
Carpet Shears				Yard Sticks

All of the above are presented in our 55 page Catalogue of Tools and Supplies for Shipping Departments, &c. We would like to send you a copy; if interested, ask for Catalogue No. 1532.

Hammacher, Schlemmer & Co.,

HARDWARE, TOOLS AND SUPPLIES

NEW YORK SINCE 1848



If its Hardware or Tools, and hard to find, try H. S. & Co.



NEW HOME, 4TH AVE. AND 13TH STREET.

BLOCK SOUTH OF UNION SQUARE

CANADA LUMBERMAN

WEEKLY EDITION

The Lumberman Monthly Edition, 40 pages} \$1.00 PER YEAR {The Lumberman Weekly Edition, every week.

THIS PAPER REACHES REGULARLY THE PRINCIPAL LUMBER MANUFACTURERS AND DEALERS THROUGHOUT CANADA, AND WHOLESALE BUYERS IN GREAT BRITAIN, THE UNITED STATES, AND OTHER FOREIGN MARKETS.

VOL. XI.

TORONTO, MONTREAL AND WINNIPEG, JANUARY 4, 1905

No. 49

CANADA LUMBERMAN

PUBLISHED BY

The G. H. Mortimer Publishing Co'y
of Toronto, Limited

Confederation Life Building - TORONTO.

Branch Offices:

33 ALLIANCE BUILDING, MONTREAL

720-721 UNION BANK BUILDING, WINNIPEG.

21 GREAT ST. HELEN'S, LONDON, E. C.

The Weekly Lumberman - Published every Wednesday, contains reliable and up-to-date reports of market conditions and tendencies in the principal manufacturing districts and leading domestic and foreign wholesale markets. A weekly medium of information and communication between Canadian timber and lumber manufacturers and exporters and the purchasers of timber products at home and abroad.

The Monthly Lumberman - A 32-page journal, discussing fully and impartially subjects pertinent to the lumber and wood-working industries. Contains interviews with prominent members of the trade, character sketches and portraits of leading lumbermen, etc. Its special articles on technical and mechanical subjects are especially valuable.

WANTED AND FOR SALE

Advertisements will be inserted in this department at the rate of 15 cents per line each insertion. When four or more consecutive insertions are ordered a discount of 25 per cent. will be allowed. This notice shows the width of the line and is set in Nonpareil type; 12 lines make one inch. Advertisements must be received not later than 4 o'clock p. m. on Tuesday to insure insertion in the current week's issue.

WANTED - 800 NORWAY PILES FOR early spring delivery. For particulars address Lock Box 12, Vineland, Ont.

FOR SALE - 1", 6/4", 2" SOFT ELM. 1", 2", 3", Birch. 1" Wormy Chestnut. 1", 6/4", 2", 3", 4" Hard and Soft Maple. 1", 6/4", 2" Beech 1", 2", 3" White Ash. 1", 2", 3", 4" Red and White Oak. Cedar Squares. R. E. KINSMAN, Hamilton.

WANTED, POSITION BY GENERAL OFFICE man, age 31, having both mechanical and business experience in lumbering and lumber manufacturing, sawmill and railroad construction, A. I. referees.—Address with particulars Box 180, CANADA LUMBERMAN, Toronto.

FOR SALE.

RED PINE DIMENSION CUT TO REQUIRED sizes. Also two parcels of standing timber, nearly all White Pine, good quality. PINE LUMBER CO., Pine Ont., near Cartier.

FOR SALE—TWO CARS OF ELM LUMBER 1" to 4" thick, one car Red Oak 1" to 4" thick, also W. Ash and Bas wood lumber. We have about 60 large W. Oak trees besides a lot of smaller ones which we intend to get out and saw this winter, large trees would average in size from 15" to 25" square and 25' to 45' long. Address BENJ. SHERK & SON, Sherkston, Ont.

SAW MILL AND TIMBER FOR SALE

NINE HUNDRED AND FIFTY ACRES OF good timber, birch, maple and hemlock. Will cut about a million and a half of logs. Reason for selling, other business to look after. Box 183, CANADA LUMBERMAN, Toronto, Ont.

FOR SALE

2,000 acres of Hardwood Land in Antigonish County, N. S., close to railway sidings. The James River runs through the centre of 1,250 acres. Apply to

J. S. O'BRIEN,
Antigonish, N. S.

EXCELSIOR WOOD WANTED—PEELED basswood or clear spruce. RANKIN AND Co., Dundas street, Toronto. Telephone.

WANTED—AN EXPERIENCED AND energetic man to sell British Columbia Shingles and Lumber in Ontario EXPORT LUMBER & SHINGLE CO., LIMITED, Vancouver, B. C.

FOR SALE—60 H.P. HORIZONTAL RETURN Tubular Boiler, good as new, bargain for quick turn-over. Address ALFRED RUBBRA, 22 Victoria Square, Montreal, Que.

WANTED—TEN THOUSAND CORDS Hard and Soft Wood; also same quantity of Slabs. SIMCOE WOOD AND LUMBER CO., 52 Yonge Street Arcade, Toronto.

HAVE YOU ANY STOCK WHICH YOU wish to sell? If so, make the fact known to probable buyers by placing an advertisement in the Wanted and For Sale Department. Address, CANADA LUMBERMAN, Toronto.

FOR SALE

FIFTY THOUSAND FEET SOFT MAPLE cut 2, 3 and 4 inches thick; it is well seasoned; also I will have for 1905 one hundred thousand feet each of hard maple, soft maple and elm to sell. Apply to C. W. TAYLOR, Bothwell, Ont.

For Sale

A FIRST CLASS STAVE AND HOOP MILL in good state of repair, and with it or not at option of purchaser, the stock of staves and hoops on hand together with a quantity of standing timber. Also horses, harness, trucks, wagons, etc. For all particulars bona fide purchasers may apply to "Staves," in care of CANADA LUMBERMAN, Toronto.

FOR SALE

1 Second-hand Engine, cylinder 9" dr., 12" stroke, heavy belt wheel 5' dr., for 8" belt, Box Bed, all overhauled and refitted with new brasses. Price F. O. B. St. John, N. B. \$175.00

1 Second-hand Exeter Engine, cylinder 10" dr., 20" stroke with Belt Wheel 8' dr. for 14" face belt, Tandy Bed, all overhauled in good order. Practically new. Price F. O. B. St. John, N. B. \$335.00

1 Second-hand Horizontal Compound Engine, 9" H. P. Cylinder, 18" L. P. Cylinder, 12" stroke with fly wheel 7' dr. Price F. O. B., St. John, N. B. \$200.00
Immediate delivery. Apply to ST. JOHN IRON WORKS LTD., P. O. Box 391, St. John, N. B.

THE LOCATORS—W. B. Herbert, General Manager. The largest and oldest exclusive Business Brokers in the West. Address THE LOCATORS, 63 Merchants' Bank Building, Winnipeg.

Cordwood.—Two hundred thousand cords of Spruce, Tamarac and Fir, for twenty thousand. Profit clear one dollar per cord, figure what that means. Can be bought for Twenty Thousand and with reasonable cash payment. Mill, store and everything needed for doing business. THE LOCATORS.

Saw Mill complete, with four lots well situated, for Three Thousand Five Hundred, Two Thousand and cash. About two hundred miles from Winnipeg everything complete. Lots of timber to cut. THE LOCATORS

Mill, Elevator, Warehouse, etc. Twenty Four thousand buys this. Mill capacity one hundred and sixty barrels. Everything complete and in running order. Will either sell or take partner with half interest. Cash payment arranged. THE LOCATORS

No doubt you are thinking of coming West and going into business for yourself. If so, consult. THE LOCATORS.

For any further particulars address THE LOCATORS, 63 Merchants Bank Building, Winnipeg.

WANTED—SOFT ELM AND BASSWOOD Lumber, 3" thick, dry. Address Box 186, CANADA LUMBERMAN, Toronto, Ont.

WANTED—A FEW CARLOADS EACH 1", 1 1/2" and 1 3/4" firsts and seconds Black Ash; state condition, price and where delivery would be made. Address Box 195, CANADA LUMBERMAN, Toronto.

WANTED—ONE MILLION PINE PICKETS, size 1" x 1" square, 24" to 48" long. To be cut this winter, not dressed, by mills in Ontario. Address Box 187, CANADA LUMBERMAN, Toronto, Ont.

FOR SALE—SAW MILL MACHINERY—Modern Saw Mill Machinery, by best American Manufacturers. Used but short time, at very low prices, owing to failure of log supply. Immediate delivery. Detailed description and prices upon application to DETROIT LUMBER COMPANY, Detroit, Mich., U.S.A.

FOR SALE—150,000 FEET OF 1 1/2" AND 1 3/4" Birch, 30,000 feet of one inch Basswood, 200,000 feet of Hemlock at \$10 F. O. B., 2x6 to 2x12, 10 to 16 feet. Two cars of sidings, 50,000 feet of Pine 1", 1 1/2" and 2". For particulars apply to the HARCOURT LUMBER CO., Harcourt, Ont.

SAW MILLS AND LIMITS FOR SALE BY the undersigned: A large lumber mill, capacity 115M per day, and a long timber mill capacity 35 per day, all in fine condition; guaranteed ready for work; situated at Little Current, Georgian Bay. If not sold soon will be willing to contract for sawing. Also Timber Berth, Township Harrow, 36 miles, and Townships Thompson, Bright and Bright Additional, 47 sq. miles. Terms of sale part cash, time for balance, 60/100. For further particulars apply to J. & T. CONLON, Thorold, Ont.

HARDWOOD LUMBER DEALERS

I CAN BUY FOR YOU AND CUT THIS winter 200 to 500M of Red Oak and Basswood, also smaller quantities of other hardwoods. Address "Hardwood," care CANADA LUMBERMAN, Toronto.

WANTED

Beveled Siding. We want delivered prices in car lots on Beveled Siding in Pine and Cedar. Present or Spring delivery.

HALEY & SON - St. Stephen, N. B.

AT FERNIE, B. C.

SAW MILL PLANT AND TIMBER LIMITS

1827 ACRES ONE AND A QUARTER miles from Fernie, B. C. heavily timbered with Cedar, Fir, Spruce and Tamarac, easily accessible for logging purposes both in summer and winter.

Saw Mill Waterous Mill with capacity of 40 thousand feet per day, with planers, lath mill, etc., all complete.

Stables, dwelling houses, store, smithy and logging camp all substantially built and ready for occupation.

The limits are held under Crown Grant and purchaser can enter and begin operations without any delay.

For further particulars, price, terms, etc., address

PH. VIBERT, ESQ.,
Manager Union Bank of Canada,

Lethbridge, N. W. T.

or H. B. GILMOUR, ESQ.,
Molson's Bank Building, Vancouver, B. C.

FOR SALE—DIRECT ACTION PORTABLE Saw Mill, now running. Box No. 4, Bothwell, Ont.

WANTED TO BUY, A GOOD SECOND-HAND Band Saw Mill. Must be in good repair. Apply Box 233, Goderich, Ont.

WANTED—1" AND 2" PINE, HEMLOCK and Basswood and Ontario Shingles. "16 and 18". Address P. O. Box 213, Almonte, Ont.

WANTED—1" BLACK ASH; ALSO FOR sale, the following: 6,500 6x9-6' 8" Red Oak Ties; 150,000' 2" Dry Indiana White Oak; 50,000' 2" Dry Indiana Red Oak. McCURE LUMBER CO., Detroit, Mich.

WANTED—PARTY HAVING PORTABLE Saw-Mill, capacity about 10,000M per day, to cut by the thousand, Temiscaming. Address "Portable," care of CANADA LUMBERMAN, Toronto, Ont.

THE LUMBER TRADE IN 1904.

The February number of the CANADA LUMBERMAN will contain the usual annual review of the lumber trade, for which the statistics are now being collected. Many manufacturers have supplied the information asked for in our circular letter, and we hope that those who have not responded will do so at once.

We shall also be glad to receive from any of our readers statistics as to production or shipments covering their district which would assist us to make our report as complete as possible.

CURRENT TRADE CONDITIONS.

ONTARIO.

Few lumber salesmen are on the road. Manufacturers and dealers are taking inventories and closing up the business for the past year. The movement of lumber, therefore, is comparatively light, although larger than at the corresponding time one year ago. Taken as a whole, the trade is in a very satisfactory condition. Stocks of the upper grades of white pine are fairly heavy, but this is offset to a large extent by the small stocks of the lower qualities. The demand for mill culls was brisk throughout the entire year, with the result that manufacturers are now almost completely sold out. There is general anticipation that the early spring will witness an active demand for white pine, and it is expected that in some grades there may be an advance. The average of prices will probably be higher than in 1904, but this will depend upon later developments. Red pine has declined considerably during the past twelve months and seems to be slow to recover.

The hardwood market is two-sided. Some dealers have contracted for large blocks of stock and believe that the tendency is distinctly upwards, whereas, on the other hand, there are ample stocks for nearby requirements, and most manufacturers are willing to accept orders at

current prices. It is known also that a few large consumers are fairly well stocked and will not be in the market for some time. As compared with one year ago, the supply of basswood is perhaps heavier than any other lumber.

QUEBEC AND NEW BRUNSWICK.

There have been few transactions in spruce lumber on which to base a prediction as to future prices. The Quebec shippers are not urging sales. Within the past month, however, conditions have improved and prices have advanced. Whether the improvement will be carried further will depend largely upon developments in the British market. There is little or no profit in manufacturing deals and selling them at current prices, and unless the return to the manufacturer shall be greater in the future, the production is likely to be much curtailed. There has been quite a recovery in clapboards, which declined from \$6 to \$8 per thousand feet during the past summer.

MANITOBA AND BRITISH COLUMBIA.

This is the dullest period of the year for the lumber trade of the West, the demand being confined almost exclusively to small lots of finishing stock. Dealers in the country districts are buying nothing worthy of note, and the next two or three weeks will be given up to maturing plans for the coming season. The outlook is uncertain. The consumption of lumber will probably be as great as during the past year, although building operations in Winnipeg may show some falling off. Prices should experience some recovery, but until conditions in British Columbia manufacturing circles improve, not much progress in that direction is likely to be made.

UNITED STATES.

The close of the year finds the lumber business of the United States in a healthy condition. No one is trying to urge sales and such orders as are being booked are largely for actual requirements, although some dealers are contracting for the new cut. Stocks of most kinds of lumber are moderate. It is estimated that there is only 90,000,000 feet of all kinds on the docks at Duluth, and of this amount less than 50,000,000 feet is unsold. No. 3 shop and better is bringing from \$18 to

\$21 on dock at Duluth, No. 1 Common \$19, and No. 2 Common \$17, while No. 3 Common is strong at \$15. In Chicago there is a scarcity of 2x12 dimension stock, on which the price has advanced from \$18.75 to \$20 within the past few weeks. The position of southern pine is very favorable. The curtailment of production has resulted in a short supply and a recovery in price. It is said that the price on car stuff has advanced from \$4 to \$6 a thousand, and yard stock from \$1.50 to \$3. The mills have plenty of orders for the new year and a further enhancement of values is looked for. The hemlock market is quiet but steady. Prices in the Signaw Valley rule at \$12 and \$12.50 for piece stuff and \$13 for boards. The movement of hardwoods is somewhat light, but the undertone of the market is firm. Quartered oak is still dragging, while plain oak sells as fast as it can be found, being in very light supply. Rock elm and birch are in some demand, with more enquiry for 2 inch than for the thinner sizes. Maple does not appear to be very strong, and estimates of 30,000,000 to 40,000,000 feet of dry stock carried over from last year have influenced sentiment somewhat. The maintenance of present prices of this lumber is about all that is expected.

It is some years since white pine lath have been so scarce and holders are able to get almost any price they ask. The recovery in the price of red cedar shingles does not seem to have held in all instances, but as the mills are still shut down, it is not easy to advance any good arguments in favor of lower prices.

GREAT BRITAIN.

Business in lumber is not expanding very rapidly, and despite the improvement which has taken place within the past month or six weeks, there is apparent on all sides a tendency towards conservatism. This may gradually pass away as the spring approaches, especially if the Russian-Japanese war should come to an early termination and money become easier. The tightness of money is doubtless exerting an influence upon the trade at the present time. There is much satisfaction in knowing that stocks of lumber on the British market are light and not likely to be greatly increased during the winter

months. This condition should lay the foundation for a healthy demand as soon as new building operations are commenced. There seems little prospect of a decline in prices of white pine or spruce for future delivery, but it is still doubtful whether the increased prices which shippers are asking will be realized. As to the spruce situation the Timber Trades Journal says:—"In spruce the rise has been more rapid than we anticipated, and for a large steamer cargo from Miramichi, with about the usual large percentage of sevens and eights, shippers were recently asking £7 for the usual West Coast range. We think it would have been better if the ascent from about £6 2s. 6d. had been through more graduated stages, and had taken more time in the process. While the Liverpool market is more than amply stocked, and there are fears that consignments during the winter may be heavy, for which purpose the liner services would be available, in London values have been kept down by the low prices ruling for competing shipments of white wood from Riga. In the Bristol Channel there are still considerable portions of the earlier and cheaper cargoes unsold, and the prices obtainable for spruce in the Midlands are so low that material advances must take place before a fair profit upon the prices shippers are now asking for cargoes can become apparent." Hardwoods are feeling the effects of a lack of demand from the cabinet trade and prices

are no more than steady. Plain oak planks are in favor and early shipments will likely bring good prices.

STOCKS AND PRICES.

The Boston Last Company are buying large quantities of logs in the vicinity of Richmond, Que.

T. A. Barrows has purchased Shaw Bros. timber limit on the west end of the Riding Mountain, N. W. T.

The North-Eastern Railway Company, of Newcastle, England, have just placed an order for 500 loads of Quebec oak.

Alex. McBeath is shipping a considerable quantity of hardwood lumber from

C. S. POWELL & CO.

Lumber Exporters

604 Temple Bldg., TORONTO
and at NEW ORLEANS, LA.

To Millmen Cash buyers all kinds hardwoods.
We solicit correspondence . . .

Planing, Matching, Resawing, etc In Car Lots.

Manufacturer of
Doors, Sash, Mouldings, Ceilings

End-Matched
and Bored . . . **HARDWOOD FLOORING**
A SPECIALTY.

Lumber Kiln Dried in Any Quantity.

J. R. EATON - Orillia, Ont.
Correspondence Solicited. Phone No. 54.

The Cook & Bros.

Lumber Co.

Of Ontario, Limited
MILLS at SPRAGGE, Algoma Dist., Ont.,
on "Soo" Branch C.P.R.

OFFICES (Manning Arcade, Toronto
Coristine Building, Montreal
And at Mills at Spragge.

MANUFACTURERS OF

White and Red Pine Lumber and Lath

Water Shipments

CEDAR LUMBER AND POLES FOR SALE

I can saw out to your order, during the winter months,
bills in heavy square Cedar, or Planks.

Have also for sale a few cars of Poles from 25 to 50 ft.

Correspondence Solicited.

J. S. FINDLAY, OWEN SOUND,
ONT.

WOODS & SPICER, Limited

.....MANUFACTURERS OF.....

BRITISH COLUMBIA RED CEDAR SHINGLES

Capacity 100 Million a Year.

We have had over 15 Years Experience, and are not Asking our Competitors for any Pointers as to Quality.

AGENTS **D. FERGUSON, LONDON, ONT.,** for Ontario.

RED DEER LUMBER CO., WINNIPEG, MAN., for Manitoba and Territories.

Wire Your Orders at **OUR EXPENSE** to Agents, or to us at **VANCOUVER, B. C.**

KNIGHT BROTHERS CO.
Burk's Falls, Ont.

KILN-DRIED BIRCH FLOORING

Send for Catalogue
& Samples by Mail

KNIGHT BROTHERS CO
Burk's Falls.

Keenan Bros., Limited

Owen Sound, Ont.

HARDWOOD, HEMLOCK AND PINE LUMBER

We carry a full supply of native Hardwoods always on hand and solicit your inquiries. At the present time we have piled at outside points about 2,000,000 feet of Hardwoods, and about the same quantity of Hardwood, Hemlock and Pine piled here in Owen Sound, and we should be able to interest you if in the market.

**WILL MAKE SPECIAL PRICES ON
BROKEN LOTS AT OUTSIDE POINTS**

ORILLIA PLANING MILL

Near G.T.R. Station
PLANING, MOULDINGS, MATCHING,
FLOORING, RESAWING, SIDING

Done any quantity. Write for price.

S. POMEROY. Phone
311

MASON, GORDON & CO.

WHOLESALE TIMBER

Montreal, Quebec

Eastern Agents The B. C. Mills, Timber & Trading
Co., Vancouver, B. C.
DOUGLAS FIR Timber in any size or length supplied
WRITE FOR PARTICULARS AND QUOTATIONS.

BULMER, McLENNAN & CO.

WANTED: Basswood, Birch, Hard Maple, Rock
and Soft Elm Lumber

Office and Yard—571 Dorchester Street, MONTREAL, P. Q.

Telephone Man 368.

Correspondence Solicited.

Kippen, Ont., to the Massey-Harris Company, of Toronto.

C. McDonald is logging in the vicinity of Temperance Vale, N. B., for George Upham. He expects to take out about 3,000,000 feet.

Eddy Bros. & Company, of Blind River, Ont., have about 9,000,000 feet of lumber on hand out of a cut last season of 28,000,000 feet. They also manufactured 8,200,000 pieces of lath and have 2,250,000 pieces on hand.

Huff & Carter, of Edmonton, N. W. T., have secured a contract to supply the Canadian Northern Railway with 100,000 railway ties, to be delivered at Battleford during the coming summer. They have secured limits west of Edmonton on which they expect to secure the necessary timber.

E. H. Lemay, of Montreal, has contracted with McLachlin Bros., of Arnprior, Ont., for the white pine lumber to be cut by them during the coming season. Some of the lumber is intended for export to the United States and will be handled through W. M. Cromble & Company, of New York.

L. J. Tweedie, Acting Surveyor General, Fredericton, N. B., will receive tenders up to January 11th for a license to cut timber on two square miles of timber lands situated on the Miramichi Portage Road and Five-Mile Brook Branch of Cross Creek. The applicant is John Gibson, and the up-

set price \$20 per square mile in addition to stumpage.

CANADIAN LUMBER SHIPMENTS.

From St. John, N.B.: Steamer Indrani, for Glasgow, 152,403 ft. deals, 1,902 ft. scantling, 1,925 ft. ends, 30 ft. boards. Steamer Orinoco, for Bermuda, 192 bdls. onion crate ends, by J. Roderick & Son; 33,000 onion crate shooks, 20,000 laths, 17,000 ft. spruce boards, plank and scantling, by G. & G. Flewelling Mfg. Co. For Antigua—100,000 shingles, by L. G. Crosby, 25,000 shingles, by T. H. Estabrooks. Steamer Lake Michigan, for London, 145,648 ft. deals, 36,000 bdls. shooks, 268 bdls. pulp, 824 pcs. maple lumber. Steamer Sicilian, for Liverpool, 45,206 ft. spruce plank, 11,681 ft. spruce ends.

From Halifax, N.S.: Steamer Briardene, for British West Indies, 16,449 ft. hemlock lumber, value \$165; 62,560 ft. spruce lumber, value \$927; 16,000 ft. pine lumber, value \$360, by Pickford & Black, agents. Steamer Manchester Importer, for Manchester, 310,606 ft. spruce deals, value \$1,249, by Furness, Withy & Co., agents. Steamer Gulf of Ancud, for London, 10,994 ft. hemlock deals, value \$990, by Furness, Withy & Co., agents. Steamer Sicily, for Liverpool, 318,192 ft. spruce deals, value \$3,647; 77,339 ft. hemlock deals, value \$773, by Furness, Withy & Co., agents.

BROOM HANDLES.

If an enterprising man with supplies of cheap Spruce, Basswood or Poplar care to put in several machines to work broom handles we can take his output. Write in first instance to Empire, care of CANADA LUMBERMAN.

THE BARBADOS MARKET.

Messrs. S. P. Musson, Son & Company's report of December 17th gives the following information regarding the Barbados market:

The fortnight under review has been barren of arrivals of white pine and spruce, in consequence of which the market shows a firmer tendency, and although there is a fair stock of second quality white pine in dealers' yards, merchantable is being enquired for and moderate arrivals of this quality would do fairly well. Spruce is in light stock, and one or two cargoes would meet with remunerative prices, as the crop season is now approaching, when there is a good demand for this class of lumber.

The steamer Dahome brought down 400 bundles of Cedar Laying Clear shingles, which were imported for a dealer, and the Blenheim from Gaspé is about due and brings a cargo of both Long and Laying, which will meet with a rather dull market, as in consequence of the drought there is not much demand, and although the stock of Long Cedar is not large it is sufficient for present requirements. Laying Cedar are still in full supply.

Shooks.—The steamer Dahome brought

down 441 bundles one trip which had been previously sold to dealers, and stocks of all descriptions are sufficient, with a cargo now due from Portland to fill requirements.

Wood Hoops.—We understand that a cargo of French is due here early in the new year, which will meet with a rather dull market, as present stocks are about all that will be required, lotting rates remaining nominal at \$20.50 for long and \$18 for short.

L. Dean Holden, Pres. J. M. Diver, Gen'l.-Mgr. A.F. Holden, Vice-Pres. E. C. Barre, Ass't Mgr.

The Cleveland-Sarnia Saw Mills Co., Limited.

Manufacturers and Wholesale Dealers in

Timber, Lumber, Lath and White Pine Shingles

Special Bills Cut to Order in White Pine, Norway and Fir, any length from 10' to 60' long.

—SARNIA, ONT.

J. D. SHIER LUMBER CO., LIMITED
BRACEBRIDGE, ONT.

MANUFACTURERS OF LUMBER, LATH AND SHINGLES

Pine, Hardwood and Hemlock Floorings and Ceilings. Sash and Doors, Wood Turnings etc. All Dressed Lumber Kiln Dried if desired End Matched Flooring a Specialty.

GOOD PINE SIDINGS A SPECIALTY

ROBERT WATT
WIARTON, ONT.

Manufacturer and Dealer in Hard and Soft Wood Lumber, Lath, Shingles, Cedar Posts and Ties.

SPECIAL: About 70 M feet of 1" Basswood. One car load of 3x4 Hardwood Hearts suitable for Car Slakes, One car each of 3" and 4x4 Cedar. Prices upon application.

THE KING AND BARTLES LUMBER CO.

PINE, POPLAR AND HARDWOODS

HEADQUARTERS HARDWOOD Citizens' Building, Cleveland, O. HARDWOOD Distributing Yard McMinnville, Tenn.

We buy and sell Pine in Car and Cargo Lots

J. B. Farwell & Son

CONTRACTORS AND DEALERS IN . .

Canadian Cedar Telegraph, Telephone and Electric Light Poles

Orillia, Ont., and Oswego, N.Y.

AT MIDLAND

100,000 feet 1 x 4 and 5 Mill Run
150,000 feet 1 x 6

Write for Prices, also for my 1905 CALENDAR. Both Good.



CHILLIWACK SHINGLE MFG. CO., LTD.

Head Office, Chilliwack, B. C. Mills at Harrison Bay.

British Columbia

Red Cedar Shingles
A SPECIALTY

Nothing Else Manufactured

B.C. Perfections, Eureka's, Clears

Shingles made from bolts cut out of standing timber on our own Timber Limits.

Dunbar Machines. Saw Jointers. Large Kilns—Slow drying Process. Experienced and skilled white labor.

THE IMPERIAL LUMBER CO., LIMITED

SAW AND PLANING MILLS, WARREN, ONT.

RED AND WHITE PINE DEALS

All kinds of SAWN LUMBER By Carload or Cargo.

BRANCH OFFICE, MANCHESTER, ENG. Head Office, TORONTO, CAN.

Registered Cable Address, "Pinewood," "American Lumberman" Telecode.

C. A. LARKIN

WHOLESALE PINE LUMBER

40 Confederation Life Building, TORONTO, ONT.

CACHE BAY LUMBER INDUSTRIES.

Geo. Gordon & Co.,

Manufacturers of RED and WHITE PINE

Band - Gang LUMBER Circular AND LATH

CACHE BAY, Ont. C. P. R. 26 miles West North Bay

CACHE BAY PLANING MILL CO.

... MANUFACTURERS OF ...

Cross Arms MOULDINGS GELING FLOORING WAINSCOTING SHEETING

All kinds of Dressed and Pine Lumber.

THE CHARLEMAGNE & LAC OUREAU LUMBER CO., LIMITED

404 Coristine Building, MONTREAL, P. Q. Mills at Charlemagne and Montcalm on Great Northern Railway.

SAWN AND DRESSED

LUMBER

Clapboards, Shingles, Laths, Butter Boxes

Write us for quotations. Shipments by rail or water.

Cedar Cove Mill,
Vancouver, B.C.

E. H. HEAPS & CO.,
Vancouver, B. C.

Ruskin Mill
Ruskin, B. C.

Lumber, Lath, Shingles, Doors, Mouldings, Etc.

SPECIALTIES :

AA1 HIGH GRADE CEDAR SHINGLES.

Cedar Bevelled Siding, Cedar Door and Sash Stock, cut to size, Cedar Finish, Base, Casing, Newels
Balusters, etc. Douglas Fir Timber up to 85 feet in length.

W. J. SHEPPARD, PRESIDENT
Waubaushe, Ont.

J. G. SCOTT, GENERAL MANAGER
Vancouver, B.C.

Pacific Coast Lumber Co.

LIMITED

VANCOUVER, B.C.

MANUFACTURERS OF

**Fir, Cedar and Spruce Lumber, Lath, Mouldings, Turned Work, Etc.
High Grade Red Cedar Shingles**

Ontario Representative, W. J. LOVERING,

112 Mail Building, TORONTO

D. C. CAMERON, President and Manager.

WM. ROBERTSON, Secretary.

J. E. YOUNG, Cashier.

The Rat Portage Lumber Co., Ltd.

Manufacturers
of

**White and Red Pine Lumber, Lath, Shingles, Sash,
Doors, Turned and Band Saw Work**

Dealers in CEDAR POSTS, POLES and TAMARAC PILING

Mills at RAT PORTAGE and RAINY RIVER, Ontario, WINNIPEG, Manitoba, and VANCOUVER, British Columbia, Head Office: RAT POTRAGE, Ontario

Our Vancouver Mill cuts High-Grade Cedar, Fir, Spruce and Red Cedar Shingles. Winnipeg Mills cut Pine, Tamarac and Spruce Lumber,
We also Manufacture all kinds of Mouldings, Sash, Doors, Turned Worked and Boxes. Correspondence solicited at all four points.

THOS. KIRKPATRICK,

MANUFACTURER OF

 **Red Cedar Shingles**

Daily Capacity,
250,000

Mills at Hastings and New Westminster

Head Office: Hastings, B.C.

Orders Solicited and Correspondence Promptly Attended to. Telephone B 1425
Ontario Representative: W. J. SMITH, Fergus.

Export Lumber & Shingle Co.

Wholesale Dealers

Limited

British Columbia Lumber and Shingles

The management of this company have had a lengthy experience in manufacturing and selling British Columbia Lumber and Shingles in Canada and the United States, and are well informed as to the requirements of the trade in those sections.

We are in a position to make prompt shipments at current market prices.

Correspondence and inquiries for prices and other information regarding British Columbia lumber conditions promptly answered.

YOUR TRADE RESPECTFULLY SOLICITED

VANCOUVER - BRITISH COLUMBIA

COOKE & TAIT

MANUFACTURERS OF ALL KINDS OF

B. C. FIR AND CEDAR LUMBER AND SHINGLES

Saw Mill, Planing Mill and Shingle Mill: False Creek, Vancouver, B.C.

WRITE FOR PRICES.

Hazelmere Lumber Co.

HAZELMERE, B. C.

MANUFACTURERS OF

FIR, CEDAR and SPRUCE LUMBER

CLEAR CEDAR AND FLOORING

Our Specialty.

Long Distance Telephone.

W. C. WELLS

PALLISER, B. C.

Manufacturer of

**High Grade Spruce, Fir, Cedar
and Lumber of all Descriptions.**

CORRESPONDENCE SOLICITED.

CANADIAN MANUFACTURERS and WHOLESALERS

THE PEMBROKE LUMBER CO.

PEMBROKE, ONT.

We have just completed a new list of all our Pine and Spruce Lumber and Dimension Timber, and will be pleased to send you a copy on application. **SOLICITING YOUR ORDERS.**

DELAPLANTE - McBURNEY LUMBER CO.,

WHOLESALE

White Pine, Hemlock, Lath, Shingles

Stocks in Ontario at { Collingwood Midland Powassan Whitney Cartier Sturgeon Falls Callander North Bay

Office, Yards and Docks, **NORTH TONAWANDA, N. Y.** Send us your enquiries

FOR Pine, Hemlock, or Hardwood, Lumber and Timber, Telegraph Poles, Ties, Posts, Lath, Shingles, Dressed Lumber, Sash, Doors, Interior Finish, End Matched and Bored Hardwood Flooring, etc., try

JOHN HARRISON & SONS COMPANY, LIMITED

We have a complete stock, two Saw Mills running in summer and one all winter. **HEAD OFFICE, SAW AND PLANING MILLS, OWEN SOUND, ONT.**

RHODES, CURRY & CO., Limited

LUMBER MERCHANTS.

Yards at Amherst, Little Forks, Sydney and Halifax.

BUILDING MATERIAL of all kinds carried in stock. We are buyers of Ontario Basswood, Elm and Pine.

Amherst, N.S.

Sawn and Hewn Spruce, Hemlock, Pine and Birch Timber, Spruce and Pine Boards and Plank, Birch and Ash Boards and Plank, Flooring, Shingles, etc.

JAMES J. MURPHY, Bank of Hochelaga Building **QUEBEC**

BOOTH & SHANNON, BISCOTASING, ONT.

MANUFACTURERS OF

Pine Lumber, Lath and Shingles

THE M. BRENNEN & SONS MANUFACTURING CO., LIMITED

Saw Mills at **RAINY LAKE, Ontario.** Planing Mill and Head Office: **HAMILTON, Ontario.**

THE NIPISSING LUMBER COMPANY, LIMITED

Mills at **CACHE BAY and SPANISH RIVER, Ontario.**

Manufacturers of and Wholesale Dealers in all kinds of **LUMBER AND LATH**

Both Railway Delivery and Water Shipments. Correspondence Solicited. **The NIPISSING LUMBER CO., Limited** Head Office: **HAMILTON, ONT.**

AUGER & SON - Quebec
PULP WOOD AND TIES

Bought at Any Station.

Also Dimension Timber, Sawn to Sizes, Telegraph Poles and Lumber.—Write Us.

A. F. BURY AUSTIN
WHOLESALE LUMBER and TIMBER
CANADA PINE

Bank of Ottawa Building, 224 St. James St., - **MONTREAL, CANADA**

SPECIALTIES: Railway Bridge Timber and all kinds of Hardwoods; Ship Decking, Norway and White Pine, Dimension Timber, Norway Car Sills, Car Flooring, Telegraph Poles, Railway Ties, Oak and Whitewood, Planed and Rough Lumber, British Columbia Pine, Southern Pine, &c.; Birch Flooring, hollow back, end butted.

Sole Eastern Agent for The North Pacific Lumber Company, Limited, Barnet, B. C.

Douglas Fir Timber in any size or length up to 90 feet long. Timber Planers face up to 24 inch x 30 inch. Kilns of large capacity. Rough and Dressed Lumber, Douglas Fir and Cedar.

WRITE FOR PARTICULARS AND QUOTATIONS.

R. LAIDLAW LUMBER CO.

18 Toronto Street, Toronto

JAS. PLAYFAIR.

D. L. WHITE.

PLAYFAIR & WHITE

Manufacturers and Wholesale Dealers

LUMBER • LATH • SHINGLES

Contractors for Railway Supplies
BILL TIMBER a Specialty

MIDLAND, ONT

A. & P. WHITE

Manufacturers of and Dealers in

Sawn and Planed Lumber, Dimension Timber. Joisting Car Sills, Car Flooring, Shingles and Lath.

PEMBROKE ONT.

F. MCGIBBON & SONS,

PENETANGUISHENE ONT.

Manufacturers of Pine, Hemlock and Hardwood Lumber, and dealers in Cordwood Hemlock Bills cut on short notice.

MAITLAND, RIXON & CO.

OWEN SOUND, ONTARIO.

Manufacturers and Dealers

LUMBER, LATH, TIES, POLES, SHINGLES, ETC.

Make a Specialty of Long Pine, Cedar and Hemlock Bill Stuff
We ship by C. P. R., G. T. R., and by Water.

Turner Lumber Co., Limited

MANUFACTURERS

LUMBER and LATH

Shipments by Rail or Water. **Midland, Ont.**

D. D. FLANNER

H. W. REEVES

FLANNER & REEVES

Manufacturers and Wholesalers of

WHITE AND NORWAY PINE LUMBER

LATH AND SHINGLES

CAR AND CARGO MIDLAND, ONTARIO

HARDWOOD FLOORING

End Matched, Bored, Steel Polished, and Bundled

Send for Price List

A few cars of selected Maple and Birch and other Hardwoods at close price

THE SEAMAN KENT CO., Limited

160 Bay St., Toronto **Factory, Meaford, Ont.**

ROBT. STEWART LIMITED

GUELPH, ONTARIO

MANUFACTURERS OF

Doors, Sash, Mouldings,

Stairs, Hardwood Flooring, Etc.

Canadian and American Hard and Soft Woods of all descriptions

SPECIALTIES

YELLOW PINE AND OAK TIMBER

Sole Canadian Representative of the

SOUTHERN CYPRESS LUMBER SELLING COMPANY
New Orleans, La.

NEW BRUNSWICK LETTER.

(Correspondence of the CANADA LUMBERMAN.)

St. JOHN, N.B., December 31st, 1904.— Since last writing very little of importance has taken place in the local lumber market. Shipments of all kinds have been light during the past month, particularly shipments by schooner to New England ports, but not more so than usual at this time of year. The lack of stimulus which always accompanies the holidays is very noticeable in both the American and English markets. Very little is being done by any of the local firms in either of these directions, either in selling or delivering.

While the quiet season lasts in the English market any change in price is improbable, as there is not enough demand to cause an advance and offerings are so light that the probabilities of a drop are practically void.

On account of these conditions any attempt to use the prevailing figures as an indication of what will prevail in the English markets in the near future would be ill-advised. Just what conditions will be predominant when the winter lethargy has been dispelled from this market it is not possible to positively state. A decidedly optimistic feeling is prevalent among the manufacturers and dealers in these parts. They are looking forward to next season,

confident that it will show a great improvement over this season in prices and demand.

In regard to prices of English deals, it would be scarcely correct to say that there has been any general advance during the last month, but it is certain that a specification containing the usual percentages of widths and of an ordinary average length could not be bought, f.o.b. steamer St. John, less than \$12.50 per M s.ft., two-thirds price for fourths and ends.

Shipments of English deals have been quite as heavy as is usual at this time of year. Although no cargo made up entirely of lumber has gone forward during that time, there were several large parcels shipped per the winter port steamers, and as there will be practically none manufactured in these parts for the next three months, there is no doubt that, when the time comes to resume sawing, it will find the wharves entirely cleaned up.

Since last writing lath have shown a further decline. As mentioned in my letter of December 1st, lath had dropped, following heavy receipts in New York and vicinity, from \$2.35 to \$2.10 per M, f.o.b. St. John. A drop of from 10 cents to 15 cents has now occurred, and Provincial lath can be bought at St. John for \$2.00 per M. Stocks are not at all heavy for

this time of the year, there being probably from four and one-half to five millions of lath distributed about the different wharves in this vicinity. In view of the decline in price mentioned above, it is altogether probable that the much greater part of these will be wintered in the hope that they will command a better figure in the early spring.

the head of the lakes for the past eight years:

Year	Total amount lumber manufactured	Total amount lumber on dock Dec. 1	Total amount unsold on dock Dec. 1
1904	285,000,000	96,000,000	51,000,000
1903	389,000,000	105,000,000	48,000,000
1902	443,000,000	119,000,000	59,000,000
1901	426,000,000	139,000,000	41,000,000
1900	416,000,000	168,000,000	126,000,000
1899	426,000,000	120,000,000	37,000,000
1898	324,000,000	120,000,000	73,000,000
1897	290,000,000	129,000,000	169,000,000

THE LATH DEMAND.

White pine and norway lath are exhibiting exceptional strength in value. There is an absolute shortage of this item. At the head of the lakes this condition is especially noticeable and it is commanding full list prices at all other points. The Mississippi Valley Lumberman says the situation cannot be remedied, but is calculated to become intensified with the advance of the building season. The mills are short of this stock and they cannot increase their output within time to meet the requirements of the demand.

WHITE PINE PRODUCTION AND STOCKS.

The white pine mills at Duluth, Minn., manufactured during 1904 approximately 285,000,000 feet of lumber, this being a falling off of 104,000,000 feet when compared with the production in 1903. Of the entire cut the stocks on dock at Duluth and Superior towards the close of December aggregated only 51,301,000 feet. The American Lumberman gives the following statistics of the production and stocks at

THE MENZ LUMBER COMPANY

Manufacturers and Wholesalers

BRITISH COLUMBIA FIR, SPRUCE AND CEDAR LUMBER RED CEDAR SHINGLES

We Solicit Your Inquiries. J. F. FOSS, Manager. 624-625 Union Bank, Winnipeg, Man.

UNITED STATES MANUFACTURERS AND WHOLESALERS

YOU
CAN
REACH

THE BONSAK LUMBER CO.
WHOLESALE HARDWOODS

ST. LOUIS
BY
RAIL, MAIL
WIRE OR
'PHONE

H. D. WIGGIN BOSTON, MASS.
89 STATE ST.
will inspect at mill and PAY CASH for

LOG RUN
Elm, Ash, Bass and other Hardwood
CORRESPONDENCE SOLICITED.

ACME LUMBER CO.
Grand Rapids, Mich., U.S.A.
Wholesale Hardwoods
Hard Maple and Rock Elm our Specialty.
We invite correspondence whether you wish to buy or sell.

YELLOW PINE
We are in position to give first - class stock. Reasonable prices. Prompt shipments. Mills in Alabama, Mississippi and Arkansas.
MANN, WATSON & CO. Muskegon, Mich.

ONE DOLLAR
Will pay your subscription to the CANADA LUMBERMAN for
ONE YEAR

WANTED 5/8 Inch Quartered Canadian Spruce and Thick Birch

J. F. QUIGLEY LUMBER CO.
94 Pearl Street - - Grand Rapids, Mich.

THE ROBERT H. JENKS LUMBER CO.
CLEVELAND, OHIO
MANUFACTURERS AND WHOLESALERS OF
YELLOW PINE, POPLAR, HEMLOCK AND HARDWOODS
Yellow Pine Timbers a Specialty

Indiana Lumber & Veneer Co.
INDIANAPOLIS, IND.

Sawed and Sliced Quartered Oak a Specialty

Correspondence Solicited. ☞☞☞☞

Veneers

CHARLOTTE HAEBERLE
Wholesale and Retail Dealer in
YELLOW PINE and OAK TIMBER
Large stock of Timbers and Bill Stuff carried in stock.
All sizes and lengths for immediate delivery.
Telephone No. 10 - - Cedar Street, NIAGARA FALLS, N.Y.

McGLURE LUMBER CO.
Wholesale Dealers in . . .

Hardwood Lumber
Carry in Stock and Have for Sale

ASH, BASSWOOD, BEECH, BIRCH, BUTTERNUT, CHERRY, CHESTNUT, COTTONWOOD, CYPRESS, ELM, GUM, HICKORY, MAHOGANY, MAPLE, OAK, POPAR, SYCAMORE, WALNUT, POLES (Oak, Hickory and Ash), RIMS and SPOKES (Oak and Hickory), OAK BENDING PLANK, OAK BILL STUFF, RAILWAY TIES.

Office and Yards: 520 to 530 Franklin St., DETROIT, MICH.
Correspondence Invited on All Hardwoods.

FRANK C. BURY **BURY & NOBLE** **MASON A. NOBLE**

WHOLESALE LUMBER - DETROIT **MICHIGAN**

Send us your inquiries for Southern Yellow Pine.

BRITISH WOOD BROKERS AND IMPORTERS

FARNWORTH & JARDINE

Wood Brokers and Measurers

Cable Address "Farnworth," Liverpool. 2 Dale St., 71 Regent Road **BOOTLE LIVERPOOL, ENG.**

F. A. Lightbody & Co.

8 Gordon Street - **GLASGOW, SCOTLAND**

WOOD BROKERS

Cable Address: "TENEBRIS," GLASGOW. Codes: A. B. C., A 1, "Zebra" and Private.
Agents for **CANADIAN WHITE PINE AND SPRUCE**; Hardwoods in Log, Etc.
Shipments handled to the best advantage to all ports in the United Kingdom. Correspondence Solicited.

EXPORT DEPARTMENT.

Correspondence solicited with exporters of wooden goods, such as Sanitary Woodenware, Broom Handles, Fork and Shovel Handles, Turned Goods, etc. Payments made on receipt of Bill of Lading at Toronto. European House.

SAMUEL SONS & BENJAMIN,
16 Philpot Lane, London, Eng.

Cable address: "Dundonian, Dundee."

BERG & SON,

Timber and Wood Pulp
Agents and Brokers
DUNDEE, SCOTLAND

Contracts made between Shippers and Importers
Correspondence solicited

SMITH & TYRER - 14 Tithebarn Street, LIVERPOOL

.. WOOD AGENTS ..

Cable Address—"Walmer," Liverpool.

Halifax, N.S., Office—SMITH, TYRER & Co., Metropole Bldg., Hollis St. Halifax, N.S

Edmiston & Mitchells TIMBER BROKERS

Cable Address: "EDMISTON" Glasgow.

33 Renfield Street, **GLASGOW**

GANT & KEMP TIMBER BROKERS

52 St. Enoch Square, **GLASGOW**

Cable Address: "TECTONA" Glasgow.
At and A B C Codes used.

CHURCHILL & SIM TIMBER BROKERS

Cable Address: "CHURCHILL" London.

29 Clements Lane, London, E. C.

Cable Address: "INVIGORATE" Liverpool.

Albert Buildings, 12 Presons Row, Liverpool, En

ZEBRA CODE

A. B. C. CODE

DIRECTORY CODE

GELLIBRAND, HEYWOOD & CO.

Wood Agents and Brokers

Cable Address: "GELLICHT," LONDON

57 Gracechurch St. London, E.C. Englan

LOUIS BAMBERGER, 2 Broad Street Building, LONDON, E. C.

IMPORTER OF

Telegraphic Address "Bellywood, London."

Pine, Spruce and all Canadian Wood Goods

Are Open to Contract for Glued-Up **BASSWOOD KEYBOARDS**

Is it your wish . . .

To Purchase or Sell as quickly as possible
A PARTICULAR LOT OF LUMBER.
A MILL PROPERTY
SECOND-HAND MACHINERY

an Advertisement in the "Wanted"
And "For Sale" Department of the

**CANADA LUMBERMAN
WEEKLY EDITION**

Will secure for you a Buyer or Seller, a
the case may be. Address.

The Canada Lumberman,
Toronto

CABLES, DOORCHECK, LONDON

We are Buyers of Pine Doors and Mouldings, Electric Wire Casings, W.C. Seats, Wooden Mantel Pieces, Sashes and Frames, and all kinds of ready made joinery.

LONDON STORES: Locke's Wharf, Edmonton, N.

STAVERS & STAVERS

OFFICES

158, Leadenhall Street, London, E.C.

Manufacturers and Importers of JOINERY

FELBER, JUCKER & CO.

Lumber Importers

MANCHESTER

ENGLAND

Invite offers from Lumbermen for . . .
Spruce Deals and Battens, Spruce and Pin
Floorings, Shooks, Sashes, Mouldings, Dowels
Broom Handles, Chair Stock, Seats, etc., or any
Woods Suitable for English Market.

Telegraphic Address: FELBER MANCHESTER.

Ashton & Petford

Bishop Lane - Hull, (England)

BUYERS OF

BOX SHOOKS AND EXCELSIOR

Invite correspondence from manufacturers who
are in a position to export.

Cable address "Shooks," Hull, A.B.C. code

JAMES WEBSTER & BROTHER

BOOTLE, LIVERPOOL, ENGLAND

TIMBER MERCHANTS

BUYERS OF Oak, Birch, Ash, Grey Elm Logs and Lumber, Elm
Staves and Heading, Handles of all description
Veneers a Specialty

JOSEPH OWEN & SONS, LTD.

Timber Importers

Cable Address "Owen Liverpool" Liverpool, Eng.

We are in the Market for

Black Walnut Logs and Boards, Pine Deals and
Siding.
White Ash Planks, best quality, in long lengths
Oak Planks, best quality, in long lengths
Rock Maple Logs and Planks, White Oak Logs
All classes of Manufactured Wood Goods
Rock Elm Logs, Waney Birch Logs

Send full particulars of what you
have to offer, with prices.

Every lumberman wants it

35 cents buys it

Scribner's Lumber and Log Book

BRIMFUL OF EVERY-DAY

PRACTICAL INFORMATION

Address:

THE CANADA LUMBERMAN Toronto

ALFRED DOBELL & COMPANY WOOD AGENTS AND BROKERS

Liverpool and London Chambers - **LIVERPOOL, ENGLAND**

CABLE ADDRESS "DOBLE LIVERPOOL"

THOMPSON, BLOIS & KJELGREN

ALL KINDS OF LUMBER AND LOGS

BRANCH OFFICES

41 Corporation St., **MANCHESTER**
Waterloo Chambers, **GLASGOW**

HEAD OFFICE

17 Gracechurch St., **LONDON, E.C.**

BRANCH OFFICE

Brook 1, **HAMBURG**

CASH ADVANCES MADE AGAINST
SHIPPING DOCUMENTS . . .

THE ONTARIO LUMBER CO. LIMITED

Mills: North Bay, C.P.R. and G.T.R. Delivery.

WHITE PINE LUMBER, LATH AND SHINGLES.

35 and 36 Home Life Building TORONTO, Ont. Mills: French River, Georgian Bay Water Shipment Only.

GEO. G. GLADMAN MANUFACTURER OF

WHITE PINE AND HEMLOCK LUMBER LATH AND SHINGLES

Mills at Smith's Bay Township of Carling

PARRY SOUND, ONT.

CORRESPONDENCE SOLICITED

WILLIAMSON & MORRISON LUMBER

Mills at L'Original, Ont.

HEAD OFFICE: 30 St. John Street, MONTREAL, P.Q.

WHOLESALE

JAS. LUNNY & CO., HINTONBURG, ONT.

Have for Sale {ASH, ELM, BASSWOOD, PINE, SPRUCE AND HEMLOCK IN QUANTITIES

Eastern Agents--B. C. Shingles and Douglas Fir, all dimensions

Can dress to 24x30.

B. C. Cedar

Write for quotations

ONE DOLLAR

Will pay your Subscription to the Weekly and Monthly CANADA LUMBERMAN for

ONE YEAR

THE WOODSTOCK LUMBER & MANUFACTURING CO., Woodstock, Ontario.

Manufacturers of and Wholesale Dealers in

Pine, Hemlock & Hardwood Lumber

ENQUIRIES PROMPTLY ATTENDED TO.

A. P. EBERT

MANUFACTURER OF AND DEALER IN

Pine and Hardwood Lumber, Lath, Shingles, Posts, Broom Handles, and Short Hardwood Dimension Stock

WIARTON, ONT.



THE NEW LINE

Through the Spruce Forests of the Laurentian Mountains--between Quebec and Hawkesbury.

WATER-POWERS, TIMBER LIMITS AND ELECTRIC POWER FOR SALE. IDEAL PULP-MILL SITES.

Unexcelled Export Facilities at Quebec.

A. J. GORRIE, General Supt.

MONTREAL

GUY TOMBS, G. F. & P. A.

CURRENT LUMBER PRICES--WHOLESALE

TORONTO, ONT.

CAR OR CARGO LOTS.

Table listing lumber prices for various grades and sizes, including Pine, Spruce, and Hemlock.

HARDWOODS--PER 1. FEET CAR LOTS.

Quality, 1s and 2s unless otherwise specified.

Table listing hardwood prices for species like Ash, Elm, Cherry, and Maple.

QUEBEC, QUE.

WHITE PINE--IN THE RAFT

Table listing white pine prices in the raft.

RED PINE--IN THE RAFT.

Table listing red pine prices in the raft.

OAK--MICHIGAN AND OHIO.

Table listing oak prices from Michigan and Ohio.

ELM.

Table listing elm prices.

ASH.

Table listing ash prices.

BIRCH.

Table listing birch prices.

OTTAWA, ONT.

MANUFACTURERS' PRICES.

Table listing manufacturer prices for various lumber grades.

Table listing lumber prices for Pine good strips, Pine good shorts, and Pine shorts.

BAY CITY AND SAGINAW, MICH.

UPPER AND SELECTS.

Table listing lumber prices for Uppers and Selects.

FINE COMMON.

Table listing lumber prices for Fine Common.

B FINE COMMON OR NO 1 CUTTING.

Table listing lumber prices for B Fine Common or No 1 Cutting.

STRIPS, A AND B (CLEAR AND SELECTS).

Table listing lumber prices for Strips, A and B.

FINE COMMON OR C

Table listing lumber prices for Fine Common or C.

SELECTED NO. 1 SHELVING OR FENCING STRIPS.

Table listing lumber prices for Selected No. 1 Shelving or Fencing Strips.

BARN BOARDS OR STOCKS.

Table listing lumber prices for Barn Boards or Stocks.

SHIPPING CULLS OR BOX.

Table listing lumber prices for Shipping Culls or Box.

SHAKY CLEAR.

Table listing lumber prices for Shaky Clear.

SHINGLES, 18-IN.

Table listing lumber prices for Shingles, 18-in.

LATH.

Table listing lumber prices for Lath.

ALBANY, N. Y.

PINE.

Table listing lumber prices for Albany, N.Y. Pine.

LATH.

Table listing lumber prices for Albany, N.Y. Lath.

Table listing lumber prices for Pine, Spruce, and Hemlock.

BUFFALO AND TONAWANDA, N. Y.

WHITE PINE.

(Wholesale selling price.)

Table listing lumber prices for Buffalo and Tonawanda, N.Y. White Pine.

The following quotations on hardwoods represent the jobber's buying price at Buffalo and Tonawanda:

Table listing hardwood prices for Buffalo and Tonawanda.

BLACK AND BROWN ASH.

Table listing black and brown ash prices.

BIRCH.

Table listing birch prices.

ELM.

Table listing elm prices.

MAPLE.

Table listing maple prices.

BOSTON, MASS.

Table listing lumber prices for Boston, Mass.

NEW BRUNSWICK CEDAR SHINGLES.

Table listing lumber prices for New Brunswick Cedar Shingles.

BRITISH COLUMBIA SHINGLES.

Table listing lumber prices for British Columbia Shingles.

THE ST. ANNE POWER COMPANY



The St. Anne Power Company was incorporated in 1902, having obtained their charter from the Government of the Province of Quebec. The principal shareholders at the time were Mr. O. W. Ordway and Mr. J. R. Loomis, jr. In 1903 Mr. Ordway purchased the shares held by Mr. Loomis and at the present time he owns the controlling interest in the company, of which he is the president and manager, while his son, Mr. Homer P. Ordway, is secretary.



ST. ANNE'S FALLS—194 FEET HIGH.

Four of Mr. Ordway's sons are in the employ of the company holding responsible positions, the other three being Henry J., superintendent mill and shipping department; Leon F., superintendent of camps; and Harry, bookkeeper at the company's headquarters, where they have a general store.

The company deal principally in spruce pulp wood, their principal place of business being at Beupre, Que., situated twenty-three miles from the city of Quebec, and on the electric

railway line of the Quebec Railway, Light & Power Company. The facilities for shipping their wood is all that could be desired, and they ship both by water and rail. The Quebec Railway, Light and Power Company found it necessary last summer to lay a siding up to their mill.

Last summer their wood was shipped mostly by canal boats. These boats come directly to the company's dock at Beupre and are loaded there by means of a conveyor. Cars are also loaded in this way, as it requires very few men to handle wood in this manner. The cost of loading is by no means high.

The River St. Anne flows into the River St. Lawrence, and the St. Anne Power Company

would give twelve thousand horse power. At the present time the company have under consideration the putting in of a plant for electric light, etc.

The limits leased by the company are extensive, comprising three hundred square miles well timbered and watered and easy rivers to drive. The headquarters of their operations are twelve miles from Beupre, and they are lumbering at present a short distance from there. The other camps are but a few miles apart. They employ in the woods about two hundred and fifty men, besides mill hands, teamsters, etc., at Beupre, where the head office is situated.

The company have fifteen thousand cords of



HEADQUARTERS OF THE ST. ANNE POWER COMPANY.

have purchased considerable property on both sides of the River St. Anne beginning at Beupre and extending as far up the river as was necessary to enable them to develop the falls and at the same time to build a large dam. We show a picture of the dam built by the company two years ago. The site chosen for same is one mile from Beupre. They have two other dams of a smaller size further up the river which are used to advantage while driving the logs to the large dam. There is always sufficient water during the summer to enable them to drive the logs from the dam to the mill to be sawed.

We also show a picture of the St. Anne's falls (on the St. Anne river), owned by the company. Engineers who have examined these all state that if they were developed they

spruce pulpwood for sale for next year's delivery.

Mr. O. W. Ordway has been connected with the business ever since he was a boy, having lumbered for a number of years in the Hudson river and in the Adirondacks. His home was in West Stoney Creek, he only coming to Beupre with his family four years ago.

The Camas Lumber Company, of Cashmere, B. C., will operate the yards and mill there formerly owned by the old Halferty-Gilman Lumber Company, which was organized in March, 1903, by L. C. Halferty and Walter E. Gilman. Last spring the old company installed a plant for the manufacture of fruit boxes. Walter E. Gilman is the general manager.



GENERAL VIEW OF DAM OF THE ST. ANNE POWER COMPANY.

250 ft. across the river; 450 ft. wing east side; 140 ft. wide; 50 ft. base up and down river; 33 ft. high; 25 feet high overflow; 14½ ft. sluice. Material used in construction: 539,964 ft. round timber; 152,875 ft. sawn lumber and deals; 11,350 yards stone; 1,600 yards gravel.

THE LEVELING OF DOUBLE-CUTTING BAND SAWS.

Begin with the hand mill and line bottom wheel with track, no lead either way ; then put top wheel in line with bottom, no crossline or overhang. The face of the wheels should have a very slight and true crown from edge to edge. This done, begin with saws and see that they are straight, no long or short back.

most light shows under straight edge in center of blade (where tension is deepest), with a gradual decrease toward the edges, until you come to the tires, which should not show any light under the straight-edge.

After this again go over this section with straight-edge, first on one edge of saw, then on the other, by holding straight-edge saw two-thirds of the way across the blade, looking

on the two tires or thickest part of saw, and when holding only two-thirds of the way across the blade, only one end of straight-edge is resting on the tension or thin part of the saw.

In like manner go over the entire inside of saw, after which put it down on the bench "on the bottom" and go over the outside of saw in the same manner as with the inside, always

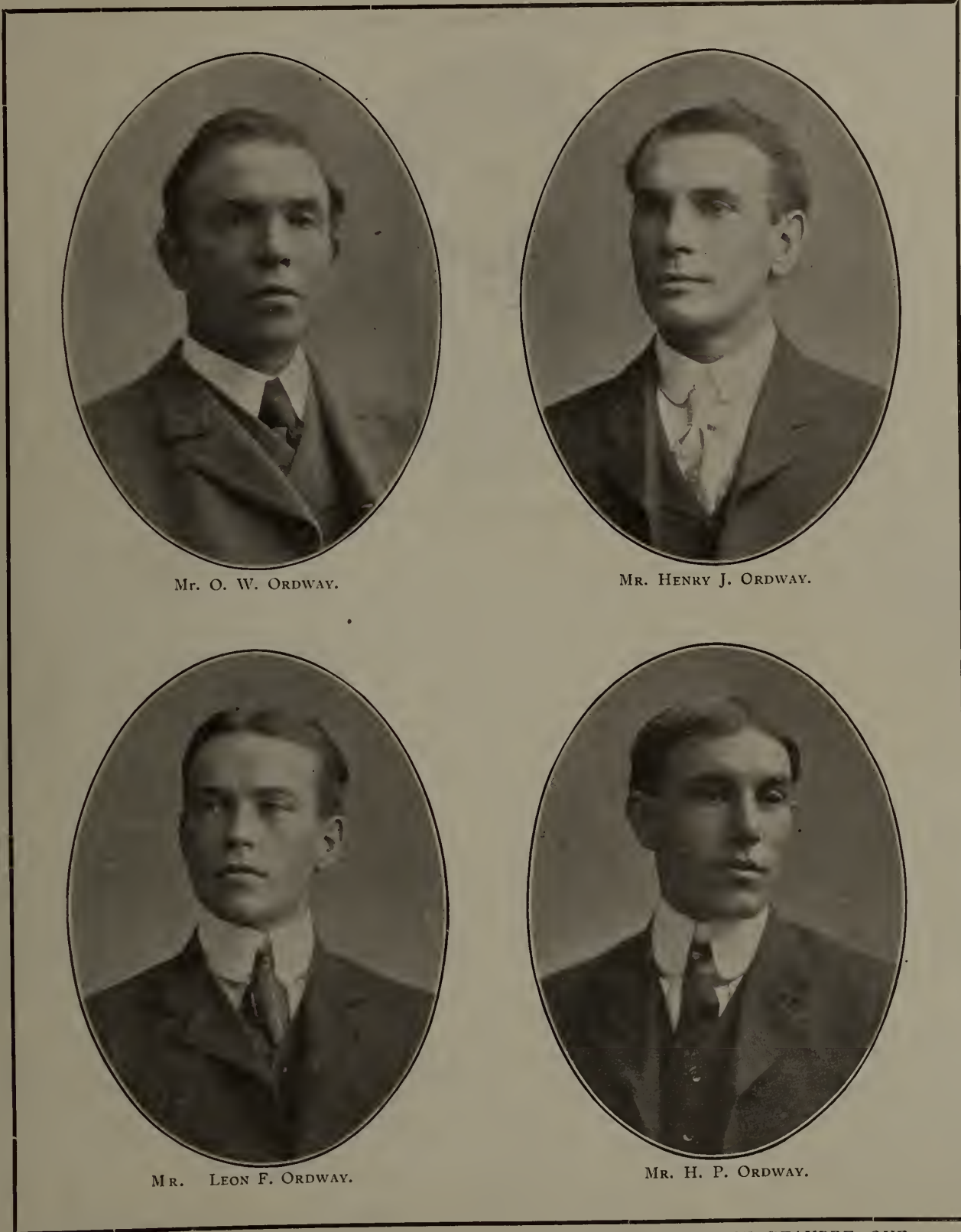

Mr. O. W. ORDWAY.

Mr. HENRY J. ORDWAY.

Mr. LEON F. ORDWAY.

Mr. H. P. ORDWAY.

OFFICERS AND SUPERINTENDENTS OF THE ST. ANNE POWER COMPANY, BEAUPRE, QUE.

Begin in the extreme center of blade and open them just enough to fit nicely over the crown of wheels and have them hug the wheel the hardest, or with the most strain, at the extreme edges of the face, with a gradual decrease in strain from each edge toward the center.

This done, put saw on top of bench and level on inside of same that part of the saw which is lying on leveling slab, by going over it with straight edge, reaching across full width of saw, and level it down so that the

for and hammering down any small lumps which may appear on the particular edge and which you were unable to locate when holding the straight-edge across the entire width of the saw.

When holding the straight-edge two-thirds of the way across the blade, the light should not show as deep under it as when holding it across the entire width of the blade, because, when holding it across the entire width of blade, both ends of straight edge are resting

bearing in mind how much light showed under the straight-edge when you were leveling the inside and trying to equalize same when leveling the outside of saw, being especially careful to have no light show under straight-edge on either side of saw from where the tension terminates at the edges. If you are not satisfied that you have the saw sufficiently level to insure its doing good work after going over each side, repeat the operation until you are satisfied.

THE LATE JOHN BERTRAM.

One of the foremost men of Canada was called away in the person of Mr. John Bertram, of whose death brief mention was made in the December issue. He was a man identified with various important industries, a man of unusual business ability, high integrity and sterling qualities. As President of the Collins Inlet Lumber Company, President of the Bertram Engine Works Company, and Chairman of the Dominion Transportation Commission, and in 1897 a member of the Ontario Forestry Commission, he occupied a public and private position which it will be most difficult to fill. It has been truthfully said that Canada could better have spared almost any other citizen.

Mr. Bertram was born in Scotland on October 16th, 1837, and left Edinburgh for Canada in 1860, settling in Peterboro, Ont. He had already learned the business of storekeeping at a little shop in Galashiels, and in 1867 he started a hardware store in Peterboro, which he conducted until 1878. Removing to Toronto, he continued in the hardware business, taking up the wholesale trade as well, and retained an interest therein up to the time of his death.

It was as a lumberman, however, that Mr. Bertram was best known. For twenty-five years he has been prominently identified with that industry. His operations were conducted under the name of the Collins Inlet Lumber Company, his limits being on the north shore of the Georgian Bay and the saw mills situated at Collins Inlet. In this, as in everything else he touched, he was eminently successful, although it was never his object to carry on extensive operations. He planned for the future rather than for the present and aimed to so lumber as to ensure a perpetual timber supply; in other words, he took off the limits each year a quantity equal only to the increment. He was a great student of the forest and had familiarized himself with the conditions to an extent which greatly assisted him in an intelli-

gent and economical management of his timber property. In late years he was a strong advocate of the principle of utilizing to the best possible advantage not only the pine timber, but also the hardwoods and hemlock which are to be found on what are commonly regarded as pine limits.

Mr. Bertram did not desire that the knowledge of forestry which he had attained through diligent research and careful observa-

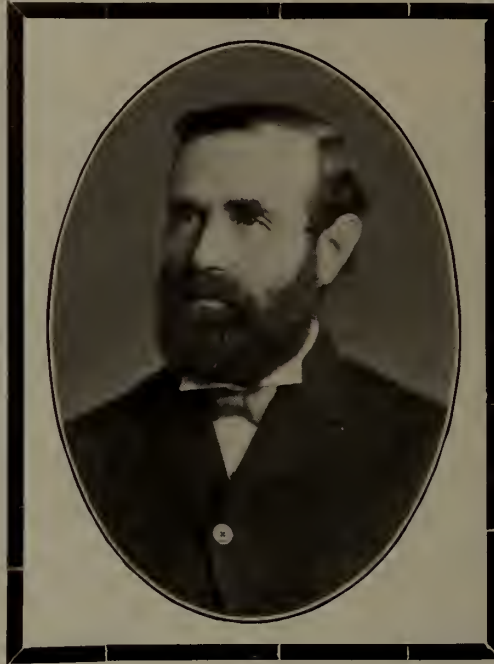

THE LATE JOHN BERTRAM.

tion should be applied for private gain alone; he preferred that the public should benefit thereby. This result was accomplished when, in 1897, he was appointed a member of the Ontario Forestry Commission to report on the subject of restoring and preserving the growth of white pine and other timber trees upon lands in the province which are not adapted for agricultural purposes or for settlement. The recommendations made by this Commission were adopted by the Government and a large area of land was added to the forest reserves. He was an active and valued member

of the Canadian Forestry Association and the author of several masterly papers on forestry subjects.

It is said that Mr. Bertram was the author of the suggestion ultimately adopted by the Ontario Legislature which prohibited the exportation of saw logs from the Province, a law which has been of great benefit to Western Ontario.

By the death of his brother in 1900, the services of Mr. John Bertram became essential in the management of the large business of the Bertram Engine Works Company. In this connection he, in January, 1902, addressed a letter to the Minister of Customs advocating greater encouragement for Canadian steel ship builders, who had to face British competition in an industry where the conditions were not at all equal.

Mr. Bertram's last field of public usefulness was as Chairman of the Dominion Transportation Commission. His appointment to this position was announced on October 27, 1903. For this work Mr. Bertram's lengthy experience in business and as a large shipper was specially valuable. Under his chairmanship the Commission had collected much information, but ill health cut short the tour he was making of Canada in June last.

Though often urged to enter public life, Mr. Bertram's political career was confined to a seat in the House of Commons from 1872 to 1878 as a supporter of the late Alexander Mackenzie. He possessed in a marked degree the gift of statesmanship, but preferred to exercise it outside of the Parliamentary arena. Nevertheless, he exerted much influence on public affairs with little ostentation and was the valued friend and adviser of men in both public and private life.

Mr. Bertram was an active member of the Unitarian church. He married Miss Helen Shields, who came out from Scotland and who, with seven children, survive him. His sons are: Hugh, of Peterboro; Robert, vice-president of the Bertram Engine Works Company; John A., lumber inspector of Little Current; and Melville, vice-president of the Collins Inlet Lumber Company.

THE E. L. PURVIS CO.,
18 COLBORNE ST. TORONTO, ONT.



PIPE AND BOILER COVERINGS

Asbestos Mineral Wool
and all kinds of Fireproofing

Material Agents for

FAMOUS MICA COVERINGS

JNO. S. FIELDING, C. E.
DAMS

Room 2, 15 Toronto Street - TORONTO

Please mention this paper when corresponding with advertisers.

C. H. VOGEL

A. M. Can. Soc. C. E.
OTTAWA, CAN. ENGINEER

Surveys, Plans, Specifications and Supervision

WATER POWER

Paper, Pulp and Sulphite Fibre Mills

Galt Machine Knife Works

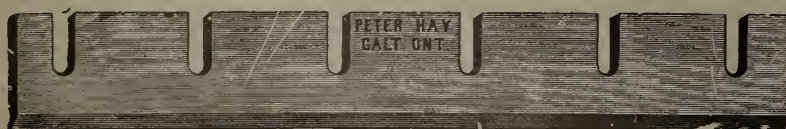

MACHINE KNIVES

OF EVERY DESCRIPTION

FOR **Woodworking Machines**

... Send for Price List ...

The Peter Hay Knife Co., Limited - Galt, Ont.

FOR THE CAMP TABLE

Mess Pork

Smoked Hams

Short Cut Pork

Roll Bacon

Plate Beef

Pure Lard

Dressed Fresh Beef

Pork Sausage

Long Clear Bacon, Butter, Cheese, &c.

Write us for Special Prices on Car Load Lots.

THE PARK BLACKWELL CO., L'T'D

PORK AND BEEF PACKERS
TORONTO

Please mention this paper when corresponding with advertisers

FOR THE CAMP

We have a very suitable lot of goods for camp supplies. We make this kind of trade a specialty. You who are not getting suited just as well as you would like, try us for your next order, and give us a chance to demonstrate our ability to give you satisfaction in this very important department of your business.

H. P. ECKARDT & CO.

Wholesale Grocers

TORONTO

A BUSY PLANT.

Our representative recently took a look in at the works of the Dodge Manufacturing Company at Toronto Junction, and was shown over the big plant by the works manager. The bright and well equipped offices, with every modern labor saving and systematizing device, each department in charge of an expert, also the well appointed Engineering Department, where countless drawers and cabinets full of all kinds of drawings all so well arranged within a great fireproof vault, seemed to offer an explanation of the busy scene which prevailed throughout the shops.

In the pattern shop a large staff of pattern makers were busy on all kinds of special work, next to this came the pattern stores, a fireproof building complete in every detail which goes to make up a modern pattern stores department. The way in which this department is laid out, with its streets and numbers and aisles, all covered by a complete directory, and in charge of a man who knows every one of the ten thousand pieces as well as one knows his own hat, was indeed a revelation. Next we went to the foundry, where we saw great quantities of all kinds of castings being made, large wheels weighing as much as ten and twelve tons each, a great quantity of large special castings for the city, columns, gasoline engines, elevator castings and all manner of castings. The Dodge Company's foundry has earned the reputation of producing good castings of any size or kind. The cupola capacity is at present fifteen tons per hour. The ease with which everything heavy is handled in this shop by the travelling cranes and other labor saving devices was remarkable. We next came to the blacksmith shop and the castings cleaning shop, which has recently been remodelled to meet the increasing business. Everything seemed most complete and arranged so that the handling was reduced to the minimum.

We then went to the immense machine shops, where great iron-working tools of all descriptions were occupied on all classes of iron work. Some of the large machines, especially the sixteen-foot boring and turning mill, seemed to cut the iron off as though it were cheese. Every department seemed to be piled up with work, and when asked where it all went to, the manager replied to all points from one end of the Dominion to the other. Lots of big work for Nova Scotia, also for British Columbia, as well as for all the other provinces, is being continually gotten out in these shops. The three motor, fifteen ton travelling crane and the industrial railway system makes it easy for the men to handle heavy work. The modern machine shop office with its complete system, including an expert cost accountant's department, the model tool room with all the latest appliances, the complete lavatories and dining rooms for the workmen, all gave evidence of the success which has crowned the efforts of the Dodge Manufacturing Company.

We next went to the castings stores building, which like the pattern stores seemed to be a model of ingenuity, a system of streets and numbers and a complete directory, all in charge of a man who seemed to have every piece of casting, no matter how small, at his finger ends, and knew just where to lay his hand on it. From this department all castings are delivered to the machine shop on requisition only, this being a part of a

most complete works system which seems to prevail throughout the entire establishment. Next we found our way to the steel storage house, where we saw over two hundred tons of steel shafting in both finished and rough state, some as small as 7/16 in. in diameter and some as large as 8 1/2 in. in diameter. The ease with which the heaviest bars could be handled was most interesting.

We then reached the wood pulley factory, where the celebrated "Dodge" wood split pulley is made. The immense quantities of parts going through made us wonder what became of all the wood pulleys, and we were surprised to hear that the shop had to run overtime almost continuously in order to keep the stock up to standard strength. The explanation was that Great Britain and the colonies are fast being educated up to the wood pulley idea, and their orders are continuously increasing. We saw one order for over 4,000 pulleys being crated for Liverpool, and others for New Zealand and Australia. The complete power house, electrical plant, dry kilns, immense lumber yard, all gave evidence of a grand organization. We were told that the employees were well looked after. Most of the men have been with them for several years and there seems no discord. The Dodge Manufacturing Company enjoy the distinction of being the only company in the Dominion who devote themselves altogether to the manufacture of power transmission machinery, and their plant is well worth a visit. The plant covers over six acres, and upwards of three hundred men are employed.

PUBLICATIONS.

The Long-Knight Lumber Company, of Indianapolis, Ind., have favored their customers and friends with an artistic callendar for 1905. It is a reminder that they carry a large stock of hardwoods and make a specialty of quartered white and red oak, plain oak, ash and cypress.

The latest catalogue received from the Wm. Hamilton Manufacturing Company, of Peterboro, Ont., is entitled "Improved Shingle Mill Machinery." Most of the machines illustrated are well-known to shingle manufacturers, having gained a reputation for durability and simplicity of operation and having given excellent results wherever used.

Users of dry kilns will be interested in the latest catalogue issued by Sheldon & Sheldon, of Galt, Ont., which points out the salient features of their natural draft moist air dry kiln. Although this kiln has been on the market for only three years, they are in use in many plants throughout the Dominion and have been found to be economical and efficient.

The American Woodworking Machinery Company, 136 Liberty street, New York, have issued an attractive pamphlet referring to the sander, a machine which seven years ago was known to very few. The first Milwaukee sander was built by them in 1894 and contained an automatic device for taking up the slack in the paper while the drum was in motion, a feature which gave the machine a decided preference over all others. It was so extensively used as to necessitate the introduction three years later of the present

Columbia sander, a heavier machine embodying many new features. One of these is an entirely new method for gripping and clamping the ends of the paper in the drum as well as to securely fasten the drum coverings. The American Woodworking Machinery Company will send one of their pamphlets to any person interested.

The B. Greening Wire Company, of Hamilton, Ont., have again favored us with their annual callendar. The design has been slightly changed owing to the addition to their buildings, which now occupy half a block on both sides of Queen street, between Peter and Napier street, in addition to an office and store room building on the corner of Queen and Napier street. This company are also issuing a series of catalogues, the first to reach us being devoted to wire cloth and perforated metal. It is perhaps the most complete and convenient catalogue of the kind which has come to our notice. The mesh in wire cloth is measured from the centre to centre of wire, which frequently leads to confusion owing to customers and others measuring between the wires. For this reason the company publish on page 21 an illustration with rule on it showing how cloth should be measured, and on page 10 an illustration showing how screening is measured—one from the centre to centre of wire—the other in the clear or between the wires. In perforated metals illustrations are given of the exact size of the dies, besides the trade number and measurement of the holes. Any reader wishing a copy of this catalogue will receive it for the asking.

GOOD HUNTING HERE.

A man would hunt a long time before he'd find a better all-round food than **Clark's Pork and Beans**. Made of select pork and prime beans by **William Clark, Montreal**. The standard for use in shanties.



Corrugated Iron
 For Sidings, Roofings,
 Ceilings, Etc.

Absolutely free from defects—made from very finest sheets.
 Each sheet is accurately squared, and the corrugations pressed one at a time—not rolled—giving an exact fit without waste.
 Any desired size or gauge—galvanized or painted—straight or curved. Send us your specifications.

The Metallic Roofing Co.
 WHOLESALE MANFRS. LIMITED
 TORONTO, CANADA.

THE NEWS

ONTARIO.

—N. Balfe proposes to build a small saw mill at Barrie, Ont.

—W. H. Wood has started a small saw mill at Brockville, Ont.

—W. J. McMillan intends establishing a shingle mill at Kinburn, Ont.

—The Gilmour Door Company, of Trenton, Ont., are increasing their power plant.

—Mitchell & McRae, saw mill owners, Powassan, Ont., have dissolved partnership.

—Jeremiah Taylor has sold his saw mill at Chatsworth, Ont., to Rhodes & Galbraith.

—The dissolution is announced of Fraser, Hamilton & Company, planing mill owners, Ottawa.

—Henry Pedwell, of Thornbury, Ont., purposes erecting a saw mill at the head of Barrow Bay.

—McKay Bros., of Galetta, Ont., have purchased the Barnet sash and door factory at Arnprior, Ont.

—H. W. Carson, of Picton, Ont., is equipping a factory for the manufacture of box shooks, doors, sashes and blinds.

—W. C. Crawford, of Tilbury, Ont., has purchased the saw mill machinery of George Maris at Chatsworth, and will move it to Tilbury.

—McKay Bros. are this winter operating a portable saw mill at Arnprior, Ont., cutting largely on custom work.

—While removing the dam at Carp, Ont., Messrs. Owens recovered a considerable quantity of oak and pine timber, which had been under water for many years.

—It is understood that W. F. Forrest intends building a saw mill at Atwood, Ont., during the coming season. He may install an electric plant for lighting the village.

—Frank Allan, who has been associated with William Allan in the saw mill business at Perth, Ont., for a number of years, has retired, and Fred, Wm. Allan's eldest son, has become a partner.

—A log of soft elm was recently taken into Wingham, Ont., which was 4 feet 5 inches in diameter, 14 feet long, and contained 2,016 feet of lumber. Logs of this size are gradually becoming scarcer.

—The Durham Furniture Company, of Durham, Ont., have decided to purchase logs and manufacture the lumber required for their furniture factory, which, of course, will necessitate the erection of a saw mill.

—It is reported that Mr. Neibergall, of Sault Ste Marie, Ont., has purchased the factory at Parry Sound, Ont., formerly operated by the Patent Clothboard Company, with the intention of engaging in the manufacture of woodenware.

—The Charlton Saw Mill Company, Collingwood, Ont., closed down their mill about the middle of November. The cut of the season comprised 13,784,000 feet of lumber, 5,500,000 feet of lath, 550,000 feet of tub and pail bottoms, 100,000 pieces of curtain pole, 3,224 cords of wood four feet in length, and 500 cords of blocks. The supply of logs came from the Spanish River, the rafts averaging about 3,000,000 feet each.

—The Upper Spanish Improvement Company, Limited, has been incorporated, with headquarters at Biscotasing, Ont., the purpose being to construct and maintain dams and other improvements to facilitate the floating of timber down that part of the Spanish river above the mouth of the Biscotasing lake and in the lakes and rivers tributary thereto. The incorporators are Robert Booth, Patrick Shannon, John A. Shannon, I. M. Booth, J. A. Shannon and Agnes Shannon.

THE EASTERN PROVINCES.

—D. A. Huntley has recently built a small saw mill and wood-working factory at Parrsboro, N. S.

—Meunier & Francouer have registered their business as sash and door manufacturers, St. Louis, Montreal.

—H. Lamonte has built a large addition to his wood-working factory at Newcastle, N. B., and has installed a new dry kiln.

—The lumber business of A. Desrochers & Cie, Quebec, Que., will hereafter be continued by Anselme Desrochers, under the old name.

—Joseph Bergeron and E. Lecompte have registered as proprietors of the lumber business of Joseph Bergeron & Company, St. Leonard, Que.

—Robertson, Wright & Company, of Shulee, N.S., will not rebuild their saw mill destroyed by fire some time ago, but will continue to operate their rotaries.

—George Upham, of Woodstock, N.B., whose saw mill at Mackawick Siding, about six miles from Millville, was destroyed by fire recently, has decided to rebuild.

—The Presbyterian Board of Home Missions, while in session at Halifax, N. S., on November 23, voted \$500 for pioneer missionary work this winter in the lumber camps on the St. John and Miramichi rivers.

—A provincial charter has been granted to the Elk River Lumber Company, Limited, of Sussex, N.B., to carry on a lumber manufacturing business. The capital is \$25,000, and J. A. McArthur and James A. Campbell, of Sussex, are interested.

—Donald Fraser & Sons, of Fredericton, N. B., have decided to build two more shingle mills, one to be located at Cabano and to have 14 shingle machines, and the other to be at Baker Brook, on the St. John river, and to have ten shingle machines.

—The James Richardson Company, Limited, has been incorporated to acquire the business and assets of James Russell at St. Jerome, Matane County, Que., and to carry on a general lumbering business. The capital is placed at \$200,000, and James Russell and

William Russell, of St. Jerome, are among the incorporators.

—The United Lumber Company, Limited, has been organized, to acquire the business of the Three Rivers Planing Mill at Three Rivers, Que. George A. Forbes, P. F. Richardson, George H. Bissett, R. T. Heneker and J. J. Robson, all of Montreal, are the incorporators.

—The Campbell Lumber Company has recently been incorporated by the Dominion Government, with a capital stock of \$75,000 and head office at Weymouth, N.S. It is proposed to carry on a general saw milling business. The incorporators are George A. Kohl, Wm. P. Sherp, R. C. McMichael, F. G. Bush and Frank Wilkinson, all of Montreal.

BRITISH COLUMBIA.

—A. G. McKay is moving his saw mill from Poplar to Fernie, B.C.

—The Allis-Chalmers Company, of Seattle, have closed a contract for a complete mill equipment for the Sayward Lumber Company, of Victoria, B.C.

—W. W. Wardrop is turning out ten cars of railway ties per day at his mill at Sparwood, B.C. He has a three year contract with the C.P.R. which will aggregate \$300,000.

—Otis Staples has a new double cutting band mill and planer almost completed near Cranbrook B.C., and expects to begin sawing early in the spring. Mr. Staples' headquarters are at Stillwater, Minn.

—John H. McLean, saw filer with the Canada Shingle Company, Vancouver, B.C., has patented an improved saw tooth which is said to accomplish good results. It is suitable for either ripping or cross-cutting.

—The Mundy Lumber Company, of Bradford, Pa., are building a saw mill at Three Valley Lake, near Revelstoke, B. C. It will have a capacity of about 15,000,000 feet annually, and will cost about \$50,000 to build. The timber will be cut on lands extending back from Three Valley Lake to Mabel and Shuswap Lakes. These are owned by the Eagle River Lumber Company, which is composed of the same shareholders as the Mundy Lumber Company.

—Several Japanese residents of Vancouver, B.C., are said to be endeavoring to enlist capital in Japan to take up the proposition either of purchasing a number of small saw mills in British Columbia or of erecting one or two large mills to supply the demand for lumber which will exist in Corea and Manchuria after the war is over. Should the required capital be forthcoming, it is probable that timber limits on the Coast would be secured and worked both for the mill supply and for the open markets. Of course, the work in the woods would be largely performed by Japanese.

MANITOBA AND THE TERRITORIES.

—A new planing mill has been built at Edmonton, N. W. T., by W. H. Clarke & Company.

—Thomas Hamilton, lumber dealer, Crandell, Man., has been succeeded by Hamilton Bros.

CRAIG MINE CRYSTAL CORUNDUM WHEELS

Our Pure Crystal Corundum Saw Gummers have no equal for their Rapid, Cool, Cutting Properties.

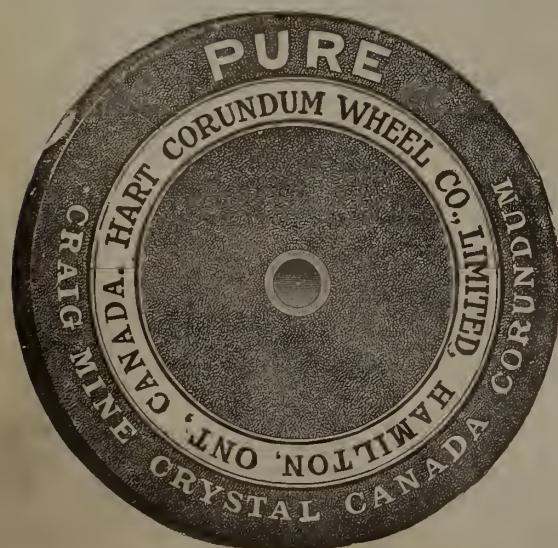

Read the following from Bulletin 180 of the United States Geological Survey, which says: "Often a distinction is made between emery and corundum, many persons not recognizing emery as a variety of corundum. Emery is a mechanical admixture of corundum and magnetite or hematite. It is, of course, the presence of corundum in the emery that gives to it its abrasive qualities and makes it of commercial value, and the abrasive efficiency of emeries varies according to the percentage of corundum they contain."

Emery is imported, mined by Greeks and Turks and contains only about 25% corundum. Our Crystal Corundum is guaranteed to be 98% pure alumina, a Canadian product, mined and manufactured by Canadians for Canadians.

HART CORUNDUM WHEEL COMPANY, Limited, Hamilton, Ont, Can.

—Holden & Company, lumber dealers, Francis, N.W.T., have sold out to D. K. McLeod & Company.

—The Telford Lumber Company are building new lumber sheds at Prince Albert, N. W. T.

—Content & McTaggart, lumber dealers, Content, N. W. T., have dissolved, Hugh McTaggart continuing.

—W. Fisher has retired from the Okotoks & High River Lumbering & Development Syndicate, Okotoks, N. W. T.

—Sanderson & Moore, Prince Albert, N. W. T., are starting a new saw mill at Crooked River, about 25 miles from Melfort.

—Brown & Rutherford, of Winnipeg, have secured the contract for supplying all the sash and frames required for the new Eaton departmental store in that city. The firm now have seventy-five men engaged in their Point Douglas mill.

—John H. Zwicker, of Mahone Bay, N.S., has just launched another vessel, making 158 vessels built at that place. Mr. Zwicker is seventy-one years of age and has been in the shipbuilding business all his life. With one exception all the above vessels have been constructed in his own yard.

—A company is in process of formation to build saw and pulp mills on the Winnipeg river near Fort Alexander, to be operated by water power. It is said that the pulp mill will be erected next summer. Messrs. Hagar and Thomas, of Minneapolis, were in Winnipeg recently in connection with the project.

—The Quebec Government has incorporated the England Lumber Company, with a capital of \$36,000, to acquire timber limits and carry on lumbering operations in that province. The incorporators are Robert A. England, of Saint Mathias of Cabano; S. C. Riou, of Fraserville, Que.; James Crawford, of Van Buren, Maine; John L. Cutler, of New York, and George C. Cutler and Frederick B. Cutler, of Boston.

WOULD NOT DO WITHOUT IT.

Messrs. Ferguson Bros., formerly of Komoka, Ont., are building a saw, planing and shingle mill at New Liskeard, Ont. In notifying of change of address, they write: "We want your CANADA LUMBERMAN to follow us. We would not do without it."

WESTERN RETAIL LUMBERMEN'S ASSOCIATION.

The annual meeting of the Western Retail Lumbermen's Association will be held in the city of Winnipeg, Man., on Wednesday and Thursday, January 18 and 19, 1905.

The official report of the fifth annual meeting of the Canadian Forestry Association has been received and is worthy of the perusal of all persons interested in forestry. It contains, besides a verbatim report of the meeting, a number of splendid illustrations of forest scenes.

THE STERN STEAMER "SASKATCHEWAN."

The latest addition to the fleet of shallow-draft steamers, owned and operated by the Hudson's Bay Company of Canada, the Saskatchewan, was recently built by that company from plans furnished by the Marine Iron Works. She is a stern wheel paddle steamer, 90 feet length of hull, and with a load draft of 24 inches. The main deck is inclosed for carrying freight, while on the upper deck is a saloon with accommodations and state rooms for several passengers.

ditions, have all been successfully met by the capable and experienced force in charge of their boat lines.

Although the Saskatchewan is one of the smaller of their river steamers, she is worthy of especial mention as being built by the Hudson's Bay Company from model plans and specifications furnished by the Marine Iron Works, Chicago, Ill., who also made the entire and complete outfit for driving machinery, with auxiliaries, special deck equipment, ironing for hull, and all the necessary fastenings.



STEAMER "SASKATCHEWAN," BUILT BY THE HUDSON'S BAY COMPANY FROM PLANS AND MODEL BY MARINE IRON WORKS, CHICAGO.

The Hudson's Bay Company was incorporated in 1670, and with a knowledge gained through an active experience of two hundred and thirty-five years in hand, with unlimited resources and equivalent energy, has most successfully covered the waters of the extreme north and northwest territories of Canada. The company's map indicates about two hundred important forts and stations; its principal offices being located in Winnipeg. The company furnishes excellent transportation by its own steamers and fleets of boats navigating all the principal lakes and streams throughout the territories not traversed by railways. The many difficult features of operation, at times conflicting con-

The machinery consists of two high-pressure engines 9 inches diameter by 42 inches stroke driving cranks in each end of the wheel shaft. This shaft is 5 1/2 inches diameter and is fitted for carrying 12 buckets 14 feet 6 inches long and 14 inches wide with the greatest diameter of 12 feet. At 35 revolutions the engines indicate 117 horse power and give a speed of 10 miles when the vessel is loaded. Steam is supplied at 180 pounds by one locomotive fire-box boiler with 16 square feet of grate surface and 666.22 square feet of heating surface.

The performance of the boat is, indeed, most creditable to the designers and builders.

The Hanchett Adjustable Saw Swage and Swage Shaper

For all sizes and kinds of Saws, Circulars, Bands, Band Resaw and Gang Saws.

A Trial Will Cost You Nothing

Let us send them to you for 30 days use free of charge. If you then feel that you can afford to do without them return them at our expense.

Filers, Mill Men, Read This!

WEST DULUTH, MINN., Nov. 14th, 1904.

HANCHETT SWAGE WORKS, BIG RAPIDS, MICH.,

GENTLEMEN:—I received your Band Swage Shaper all O. K. I am VERY MUCH PLEASED WITH IT, and am sorry I did not get one before. My saws run better and stand more feed. I have been using the—Shaper made by the—. Please find enclosed P. O. money order to balance my account.

Yours truly,

M. E. ALLEN.

(Mr. Allen is an expert filer and saw maker and is with the Red Cliff Lumber Co. at a high salary.)

THEY SAVE TIME, FILES, LABOR, SAWS

Write for Circular to—

HANCHETT SWAGE WORKS, BIG RAPIDS, MICHIGAN, U. S. A.



(HANCHETT BAND SWAGE SHAPER)

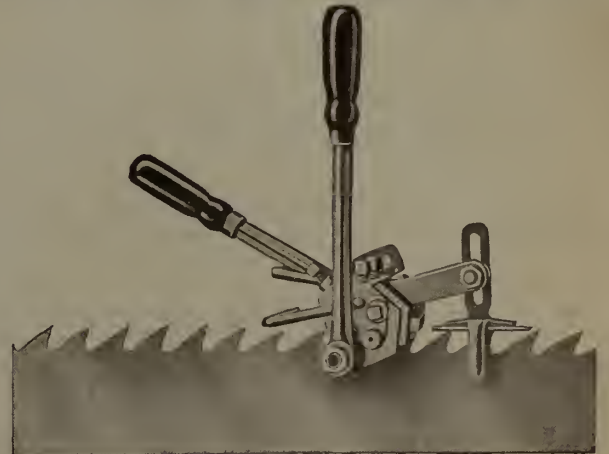

(HANCHETT BAND SAW SWAGE)

CLASSIFIED INDEX OF ADVERTISERS

AXES	CRATES	Georgian Bay Engineering Works—	SAWS
Dundas Axe Works. 72	Gordon Hollow Blast Grate Co. 79	Grinders. 77	Atkins & Co., E. C. 83
ALLIGATOR TUGS	LUMBERMEN'S STOVES	Huther Bros.—Dado Heads. 83	Burns Saw Co., E. R. 3
West & Peachey. 78	Gurney Foundry Co. 68	International Correspondence School. 85	Buckeye Saw Mfg. Co. 59
BELTING	LUMBERMEN'S SUPPLIES	Imhauser & Co.—Watchman's Time Detectors 84	Hoe & Co., R. 6
Dominion Belting Co. 87	Johnson, A. H. 78	Lumber Mutual Fire Insurance Co. 74	Oldham & Sons, Joshua. 19
Fairbanks Co. 72	Merchants Rubber Co. 72	McFarlane-Neill Mfg. Co.—Cant Dogs. 83	SAW MILL MACHINERY
Gutta Percha & Rubber Mfg. Co. 79	Park, Blackwell Co. 64	Metallic Roofing Co.—Corrugated Iron Spence & Co., R.—Files and Rasps. 3	Allis-Chalmers Bullock, Limited. 5
Goodhue & Co., J. L. 3	Rice, Lewis & Sons, Limited. 90	Scribner's Lumber & Log Book. 6, 15	Bartlett & Co., A. F. 84
McLaren, D. K. 3	Turner & Sons, J. J. 77	Toledo Fire Insurance Co. 71	Bell Engine & Thresher Co., Limited, The Robert. 83
McLaren Belting Co., J. C. 90	Thompson Mfg. Co. 70	Vogel, C. H.—Pulp Mill Engineer. 64	Dunbar & Sons, Alex. 20
Sadler & Haworth. 18	Woods, Limited. 3	OILS	Hamilton Mfg. Co., Wm. 4
Waterous Engine Works Co. 6	LUMBER AND SHINGLE MANUFACTURERS	Commercial Oil Co. 84	Killam, M. L. 80
Wilby, P. H. 24	Big Bend Lumber Co. 14	Canadian Oil Co. 59	Lane Manufacturing Co. 73
Young, J. S. 3	B. C. Mills, Timber & Trading Co. 15	Queen City Oil Co. 6	Lloyd Mfg. Co. 89
BUILDING BLOCKS	Brunette Saw Mill Co. 91	PROVISIONS	Long Mfg. Co. 8
Cement Building Block Co. 70	Canadian Pacific Lumber Co. 13	Clark, Thos. 64	Mershon & Co., W. B. 70
BABBITT METALS	Cloverdale Milling Co. 13	Eckardt & Co., H.P. 65	Mowry & Sons, B. R. 81
Robertson Co., The James. 90	Crows Nest Pass Lumber Co. 13	PORTABLE SAW MILLS	Owen Sound Iron Works. 6
Syracuse Smelting Works. 59	Columbia River Lumber Co. 13	Bell Engine & Thresher Co., Robt. 83	Oxford Foundry & Machine Co. 84
BOILERS	Delta Saw Mill Co. 14	Drake, F. J. 22	Petrie, H. W. 6
Canada Foundry Co., Limited. 24	East Kootenay Lumber Co. 14	Oxford Foundry & Machine Co. 84	Payette & Co., P. 74
Dyment Foundry Co. 86	Fernie Lumber Co. 13	Owen Sound Iron Works. 6	Schaaque Machine Works 20
BOILER INSURANCE	Great Northern Lumber Co. 15	PLANERS AND MATCHERS	Shurley & Dietrich 10
Boiler Inspection & Insurance Co. 76	Hadden, D. & J. 14	Clark & Demill 11	Stuart Machinery Co., The 12
Canadian Casualty & Boiler Insur- ance Co. 69	Haslam, A. 8	PULLEYS	Smart-Turner Machine Co. 90
DOORS	Heaps & Co., E. H. 21	Dodge Manufacturing Co. 9	Waterous Engine Works Co. 88
New Century Refrigerator & Mfg. Co. 72	Knight & Son, G. T. 70	PACKING AND PIPE COVERING	Williams, Madison. 81
DRY KILNS	King Lumber Mills. 13	Eureka Mineral Wool & Asbestos Co. 75	SHINGLE MILL MACHINERY
Andrews Co., The A. H. 20	Leigh & Sons, Jas. 78	Garlock Packing Co. 24	Dunbar & Sons, Alex. 20
Clay Dry Kiln Co. 79	Ladysmith Lumber Co. 15	Purvis Co., E. L. 64	Drake, F. J. 22
McEachren Heating & Ventilating Co. 89	Moyie Lumber & Milling Co. 13	ROPE	Long Mfg. Co., E. 8
Sheldon & Sheldon. 89	Menz Lumber Co. 89	Canadian Cordage Co. 80	Owen Sound Iron Works Co. 6
Standard Dry Kiln Co. 89	Morth Star Lumber Co. 14	Consumers Cordage Co. 74	Schaaque Machine Works 20
ELEVATING AND TRANSMITTING MACHINERY	Pigeon River Lumber Co. 14	Dominion Wire Rope Co. 24	Williams, Madison. 81
Buhl Malleable Co. 24	Rat Portage Lumber Co. 91	Greening Wire Co., B. 3	STEAMERS
Dodge Manufacturing Co. 9	Robinson-McKenzie Lumber Co. 14	Mussen & Co., W. H. C. 3	Marine Iron Works. 77
Perrin & Co., R. 84	Sayward, J. A. 15	Sonne, Thos., Sr. 3	TURBINES
EMERY WHEELS	Taylor & Co. 78	RE-SAWS	Williams, Madison. 86
Hart Corundum Wheel Co., Limited. . 66	Victoria Lumber & Mfg. Co. 14	Cowan & Co. 23	WOODWORKING MACHINERY
ENGINES AND LOCOMOTIVES	Yale-Columbia Lumber Co. 13	Giddings & Lewis Mfg. Co. 82	American Woodworking Machinery Co. 16-17
Doty Engine Works Co. 77	LUMBERMEN'S TOOLS	SAW SWAGES	Clark & Demill. 11
Dyment Foundry Co. 86	Baldwin, Tuthill & Bolton. 20	Crowell, D. J. 74	CConnell & Dengler Machine Co. 87
Gartshore, John R. 77	Burton Saw Co., J. A. 85	Hanchett Swage Works. 67	Coe Mfg. Co., The. 11
Owen Sound Iron Works. 6	Hammacher, Schlemmer & Co. 60	SAW GAUGES	Cowan & Co., Limited. 23
Robb Engineering Co. 83	Hamilton Stamp and Stencil Works. . 94	Specialty Mfg. Co. 84	Dodge Manufacturing Co. 9
MISCELLANEOUS	Hay Knife Co., Peter. 60	STEAM BOILERS	Defiance Machine Works 11
Alexander Engraving Co. 3	Pink, Thomas 90	Canada Foundry Co. 24	Mitts & Merrill. 87
Bradstreets. 6	CONFEDERATION LIFE ASSOCIATION	Owen Sound Iron Works. 6	Perkins & Co. 87
Confederation Life Association. 12	Canadian Office & School Furniture Co. 6	VENEERS	Rogers Iron Mfg. Co. 85
Canadian Office & School Furniture Co. 6	Denton, Dunn & Boulton, Barristers. 85	Rider & Kitchener Co. 77	Sherman Co., W. S. 84
Department of Lands, Mines & Fisheries Province of Quebec. 5	Department of Crown Lands, Province of Ontario 92		Shimer & Sons, Samuel J. 85
Department of Crown Lands, Province of Ontario 92	Fielding, J. S., Consulting Engineer. . 64		Stuart Machinery Co. 12
Glenyards Fire Clay Co. 70			Waterous Engine Works Co. 88

OXFORD VULCAN

A HEAVY STOVE FOR

LOGGING CAMPS, RAILROAD CONSTRUCTION GANGS,
HOTELS, BOARDING HOUSES, ETC.

Cooking Holes, 6-10 inch; Oven Dimensions, 25x28x16 in.; Fire Box for
Wood, 28 inch; Fire Door Opening, 8x8½ inch.

WE MANUFACTURE THE OXFORD "CAMP" TUBULAR HEATER

The Gurney Foundry Company, Limited

TORONTO

WINNIPEG

VANCOUVER

The Gurney Massey Co., Limited,
Montreal, Que.

The Gurney Standard Metal Co.,
Calgary, Alta.

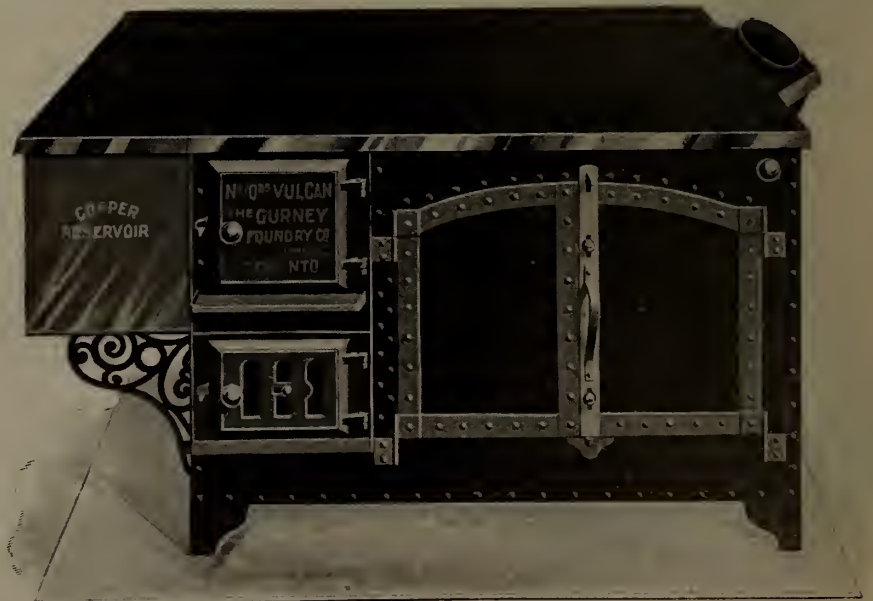

Why Not?

Have that Comfortable Feeling and Perfect Security in connection with your Steam Boilers that a policy with

The

Canadian Casualty and Boiler Insurance Company

always gives. Long years of capable experience at steam engineering at your service free of cost. Our Engineers' Advisory Department has proved invaluable to our policy holders—as a policy with us will substantiate.

Head Office:

22-24 Adelaide Street East, TORONTO

Branch Offices in

Montreal, Vancouver, Winnipeg, and the Chief Cities and Towns in Canada

A. G. C. Dinnick, Managing Director A. M. Wickens, Chief Engineer

WRITE US FOR INFORMATION

FORESTRY DEPARTMENT

TREATING TELEGRAPH POLES.

For the last two years the United States Bureau of Forestry has been co-operating with the American Telephone and Telegraph Company, and recently with the Postal Telegraph-Cable Company also, in an experimental study to increase the durability of telegraph and telephone poles.

The length of service of a telegraph or telephone pole is determined in a section of the pole not more than a foot or a foot and a half long. In a standing pole this section extends about six or eight inches above and below the top of the ground. This is the universal point of attack upon the life of the pole, and is called its breaking point. Decay is the arch-enemy of these poles. It sets in at the ground line and reaches both up and down the pole, but only so far as the conditions exist which promote the growth of wood-destroying fungi. A few inches below the ground there is lack of the necessary oxygen and heat, while at about the same distance above ground the requisite moisture fails. The exact time at which decay begins its work depends upon the climate, the character of the soil, and similar conditions. In a hot, moist climate it ordinarily sets in with great rapidity. But at best, in a very few years after the pole is set the struggle

has commenced. The decay soon girdles the pole and gradually eats into it deeper and deeper until it is so weakened that it breaks under the weight of its equipment.

The strain upon the pole from wind pressure and the weight of its cross-arms and wires is calculated for the ground line. When the diameter of this ground line is constantly decreased, the strength of the pole is proportionately reduced, and it becomes only a question of time when the pole must fall. Chestnut and white cedar have been found, among available woods, most successfully to resist decay; but the life of the former is only from twelve to fifteen years, and of the latter ten to twelve years. The cooperative study of the Bureau is for the purpose of extending, if possible, this time.

The experiments already made by the Bureau show conclusively that poles can be subjected to a preservative treatment which insures materially lengthened service. The treatment consists in impregnating the wood with antiseptics which prevent the growth of the fungi that cause decay. The treatment of telegraph poles, when attempted at all in this country, generally has been applied to the whole pole, requiring the use of air-tight cylinders 100 feet long or more. In these the poles are subjected to live steam for some time, when a vacuum is created. Creosote is then run in and pressure applied to force it into the wood. Manifestly this is a laborious process. Yet for

telegraph and telephone poles only about 1 foot of the entire length needs to be made immune from fungus. If this foot at the fatal ground line can be preserved from decay, the rest of the pole will take care of itself. Experiments will now be made in treating the butts of the poles for a distance of about 8 feet, thus carrying the antiseptics just beyond the zone of decay attack. The creosote method will be used and dead oil of coal tar forced through the butt of the pole.

THE AMERICAN FOREST CONGRESS.

The American Forest Congress will be in session at Washington, D.C., before this number reaches its readers. The meeting promises to be very interesting, as a large number of papers have been arranged for. The session on Wednesday morning, January 4th, will be devoted to "The Lumber Industry and the Forests." Twelve papers will be read, which will include the following: "Importance of Forestry to the Wood-working Industries," by M. C. Moore, Secretary National Slack Cooperage Manufacturers' Association; "Rise in Value of Stumpage," by James T. Barber, President Barber Lumber Company, Wisconsin; "Importance of Lumber Statistics," by G. K. Smith, Secretary National Lumber Manufacturers' Association; "Is Forestry Practicable in the Northeast," by John A. Dix, President Moose River Lumber Company, New York. Other sessions will be devoted to the following subjects: Importance of the Public Forest Lands to Irrigation; Importance of Public Forest Lands to Grazing; Railroads in Relation to the Forest; Importance of Public Forest Lands to Mining.

1,000 Mershon Band Resaws

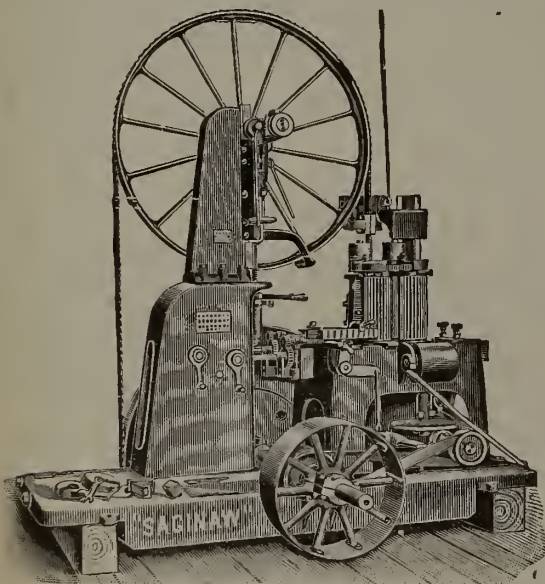

IN DAILY USE

BUY DIRECT AND GET

— THE —
GENUINE

W. B. MERSHON & CO.

Saginaw

Mich., -- U. S. A.

A Money Maker for Lumbermen



The —
**Normandin
Cement Block
Machine**

Ten Machines in One

The machine which is adopted and used by the United States Government Engineers. One Machine only for any size block. Makes blocks any height from 1 to 9 inches. Makes blocks any length from 1 to 31 inches. Makes straight blocks and corner blocks in the following widths: 6, 8, 10, 12 and 14 inches. Adjustable cores, sides and ends. Fastest Machine made. Will make one block per minute. 200 Houses built in the West this year of blocks made on our machines.

Write for prices for Spring Del very. We are sole agents for Canada.

We sell the best brands of Portland Cement

Up-to-date Lumbermen should install a block plant in connection with their Lumber business.

THE CEMENT BUILDING BLOCK CO., LTD.

Branch Offices { 42 Yonge St. Arcade, Toronto.
2 Pender Blk., Vancouver.

MERCHANTS BANK BLDG., WINNIPEG

Please mention this paper when corresponding with advertisers.

PAT. OSCILLATING BOB SLED KNEE

Hauls 25 per cent. easier, and wears longer, and is lighter than all others.

THOMPSON MFG. CO., Ltd.,
Grand Bay, N. B.

Please mention this paper when corresponding with advertisers.

G. T. KNIGHT & SON

Manufacturers of

Building Supplies

we make a specialty of

Doors and Sashes; Mouldings and all kinds of turned goods.

Address, MEAFORD, ONT.
Excellent shipping facilities, by rail and water.

Fire Clay Products

THE GLENYARDS FIRE CLAY CO.

BONNYBRIDGE, SCOTLAND.

Cablegrams: Glenyards, Bonnybridge.

Codes used, A.B.C. and Glenyards.

Manufacturers of all kinds of **Fire Clay Goods, Ganister and Silica Goods, for Iron and Steel Works and Gas Works, including Boiler Seating Blocks and Covers of all sizes. Ground Fire Clay, Ganister and Silica** in all kinds of Packages

The Headquarters for Lumber Insurance is

66 BROADWAY, NEW YORK

the home office of the

Lumber Insurance Company of New York

and the

Lumber Underwriters

The Toledo Fire and Marine Insurance Company

will reinsure the above companies or write direct any risk accepted by either.

All are backed by big lumber interests in Canada and the United States, and insure lumber and wood-working risks only. By doing business direct with the assured they guarantee him fair rates. For a quotation write to

66 BROADWAY

FOR DIRECT INSURANCE BY THE
TOLEDO FIRE AND MARINE INSURANCE COMPANY
WRITE TO SANDUSKY, OHIO

TRAINED FORESTERS WANTED.

As showing the practical interest which lumbermen are now taking in forestry, Mr. Thomas Southworth, Director of Colonization and Forestry, recently received a letter from an American owning large limits in Algoma, asking where he could get a trained forester. He wants an expert in that line to make an examination of his limits and lay down a plan for cutting timber in such a way as to conserve the young growth.

LUMBER INSURANCE.

The Lumber Insurers General Agency has begun the publication from 66 Broadway, New York, of a small monthly magazine devoted to the interests of insurance, and to that part of it particularly which is of interest to lumbermen, namely, specialized insurance on lumber and woodworkers. The name of the new publication is Lumber Insurance, and its stated aim is to publish items that will prove readable and interesting to lumbermen all over Canada and the United States. Its columns will be by no means limited to the discussion of the subject to which its title would appear to confine it, but will contain as well news of

the lumber trade and occasional articles of economic value. Sixty-six Broadway is the home of the Lumber Insurance Company of New York and the Lumber Underwriters, and it is to the policy holders and friends of those companies that the magazine will go. Those who have business relations with the Toledo Fire & Marine Insurance Company of Sandusky, Ohio, will also receive copies, as the last named company is closely connected with the two named above.

MUCH PLEASSED WITH IT.

Mr. H. A. Benjamin, Shubenacadie, N.B., in remitting for his subscription to the CANADA LUMBERMAN says: "I am much pleased with your paper."

DUNDAS AXES



have steadily worked their way to the front and are now ahead of all others in shape and quality. Our Dundas Lumberman Axe tempered by our new process is more uniform in temper and will wear longer than any Axe in the market. If you have not already used them a sample order will convince you of the justice of our claim.

THE DUNDAS AXE WORKS
DUNDAS, ONT.

Please mention CANADA LUMBERMAN when corresponding with advertisers.

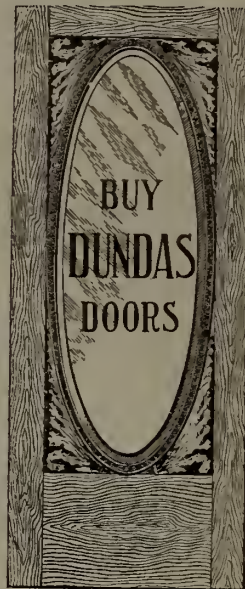

New Century Refrigerator & Manufacturing Co., Limited

Dundas, Ont., Can.

Our Business is Manufacturing

HARDWOOD VENEER . . DOORS

With Built Up Bodies

These Doors are guaranteed not to warp or twist and are superior in construction and finish to any other Door on the market.

Send for Illustrated Catalogue and Prices.

Special attention given to Architects' Designs of Doors and Trims.

AGENTS WANTED EVERYWHERE. ADDRESS DOOR DEPARTMENT



GENUINE DUCK BRANDS - NONE BETTER - SATISFACTION GUARANTEED
MANUFACTURED BY

THE MERCHANTS RUBBER COMPANY., Limited
BERLIN, CANADA



WHEN FIXING UP YOUR MILL

For next spring's business we would like to hear from you regarding the Belting you will doubtless require. In the manufacture of



FAIRBANKS'  BRAND LEATHER BELTING

we think we have attained a higher degree of excellence than was heretofore obtainable. We use nothing but the best Packer's Butts and then only the toughest part of these. The belly and the working parts of the animal we do not use at all, and every belt from six inches up has the backbone strip of the animal in it. We carry a complete stock and can make prompt shipment. Write to us about it.

The Fairbanks Co.

Montreal

Toronto

Vancouver

Winnipeg

THE BEST QUALITY
 OF LUMBER **AT THE LOWEST COST**
 OF PRODUCTION (EVERY ITEM INCLUDED) IS SECURED BY THE USE OF
THE ORIGINAL
LANE SAW MILLS

ADAPTED TO ALL KINDS, SIZES AND LENGTHS OF LOGS. TEN SIZES, CAPACITY FROM 3,000 FT. UP PER DAY.
 The Best of Materials and Workmanship Throughout.

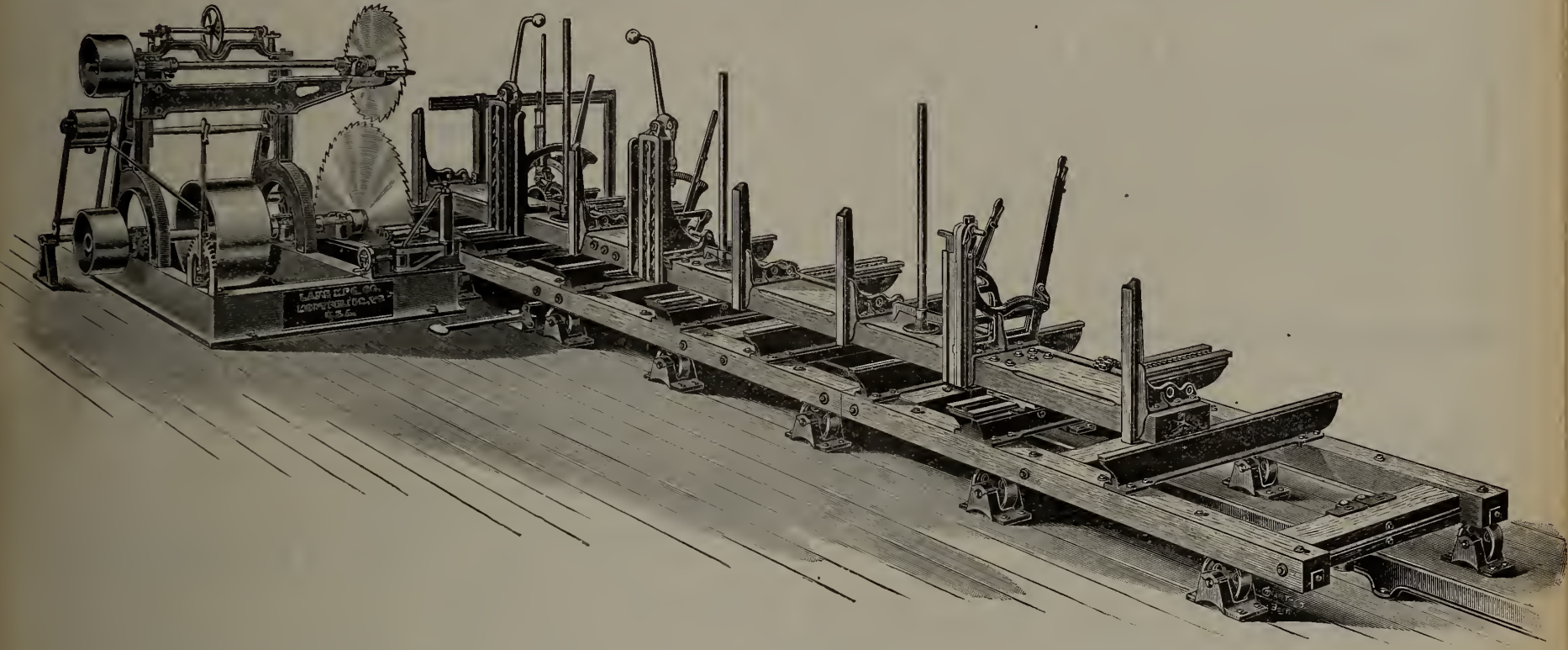

NO. 3 MILL, WITH CENTER GUIDE. RACK HEADBLOCKS, STEEL FACED, ALL REINFORCED AT POINT

Designed for Use with Steam Feed, Loader, Nigger and Buffers, and for the
FASTEST - POSSIBLE - SAWING.

Can furnish with Heavy Friction Feed for Water Mills, also with 14 in. Steel Trucks on 3 in. Steel Axles extending across the Carriage, and Steel Rail Track, instead of Chairs and Rolls and Center Guide, if preferred.

RIGHT OR LEFT HAND, SINGLE OR DOUBLE

HIGHEST AWARD ————— **GOLD MEDAL**

At the South Carolina, Intersate and West Indian Exposition

WE ALSO MANUFACTURE A MOST COMPLETE LINE OF

SAW MILL CARRIAGES, SET-WORKS, DOGS AND OTHER ATTACHMENTS,

Feed Works, both Steam and Friction,
 Offsets, Air Buffers, Log Jackers,
 Canters and Niggers, Log Car Trucks,
 Log Rolls, both Live and Dead,
 Log Cutting-Off Machines, Log Unloaders,
 Stops and Loaders,
 Lumber Rolls, both live and dead,

Lumber Transfers,
 Lumber Car Trucks, Lumber and
 Timber Edgers, Lumber C-O Machines,
 Trimmers, Slashers, Etc., Planers, Matchers
 And Jointers, Lath, Shingle and
 Heading Machinery, Clapboard Machinery,
 Universal Sawing and Jointing Machines,

Belt Tighteners, Swing and Slide,
 Water Wheels, Traveling Cranes,
 Power Transmission and Conveyor Machinery
 Boom Derricks up to 100 Tons Capacity,
 Derrick Turning Gears, Steam or Air.

LANE MANUFACTURING CO., MONTPELIER, VERMONT, U. S. A.

Catalogues and Prices—"Ask and you shall receive."

TRADE NOTES.

The business of the John Bertram & Sons Company, manufacturers of tools, etc., Montreal, has been registered.

The Ottawa Saw Company have recently made a large shipment of band and other saws to a lumber firm in Tasmania.

The Disston Saw Works, of Philadelphia, have completed arrangements for the erection of a factory on Adelaide street east, Toronto, to cost upwards of \$150,000.

Attention is directed to the advertisement first appearing in this number of the Thompson Manufacturing Company, Grand Bay, N. B., manufacturers of Patent Oscillating Bob Sied Knees, for lumbermen's use.

Sheldon & Sheldon, of Galt, Ont., have recently sold steel pressure blowers to the Canadian Westinghouse Company and the International Harvester Company, of Hamilton, and the Goldie & McCulloch Company, R. McDougall Company and Cowan & Company, of Galt.

We understand that the Garlock Packing Company, of Hamilton, Ont., have had an exceptionally busy season and are finding a steadily increasing demand for Garlock's ring, spiral, waterproof hydraulic and high pressure packings, of which they are exclusive manufacturers. They have shipped considerable quantities to Great Britain, and anticipate a still larger demand from that source during the coming year. They are also doing a large trade in asbestos pipe and boiler coverings and engineers' supplies.

The Canada Gazette announces the incorporation of the Canada Saw Company, Limited, of Ottawa, with a

capital of \$125,000. The object of the new company is stated to be to acquire the business and property of the Ottawa Saw Company, as well as the whole or any part of the property, plant and other assets of the branch of the business of the James Robertson Company, Limited, relating to the manufacture and sale of saws at Toronto, Montreal and St. John, N. B. The members of the company are P. M. Feeney, John I. McCracken, Charles McGee, G. H. Binden and W. S. O'Dell, of Ottawa; and J. M. H. Robertson and F. Bacon, of Montreal.

P. PAYETTE & CO.

Manufacturers of Saw Mill and Engine Machinery, and all kinds of Marine Machinery.

PENETANGHISHENE, ONT.

THE LUMBER MUTUAL FIRE INSURANCE COMPANY

BOSTON, MASS.

STRENGTH

ECONOMY

NET ASSETS, NOVEMBER 30, 1904

DIVIDENDS TO POLICY HOLDERS

\$577,717.66

30%

MAIL EXPIRING POLICIES WITH YOUR ORDER.



These Mules Cannot Break This Yarn

BECAUSE IT WAS MADE BY THE

Consumers Cordage Co., Limited

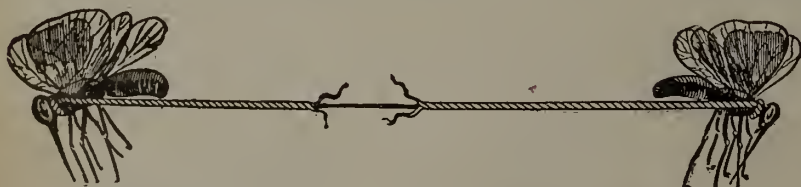

Poor Yarn is Dear at Any Price

We Manufacture

**Double and Single Lath Yarn,
Shingle Yarn, and Cordage**

Of Every Description

Our mills are equipped with the latest improved machinery for making extra long lengths of Transmission Rope.

CONSUMERS CORDAGE CO., LIMITED
Montreal and Halifax

Circular

Saw Swage

Can be used on Band Saws simply by using the Band Saw Front Gauge.

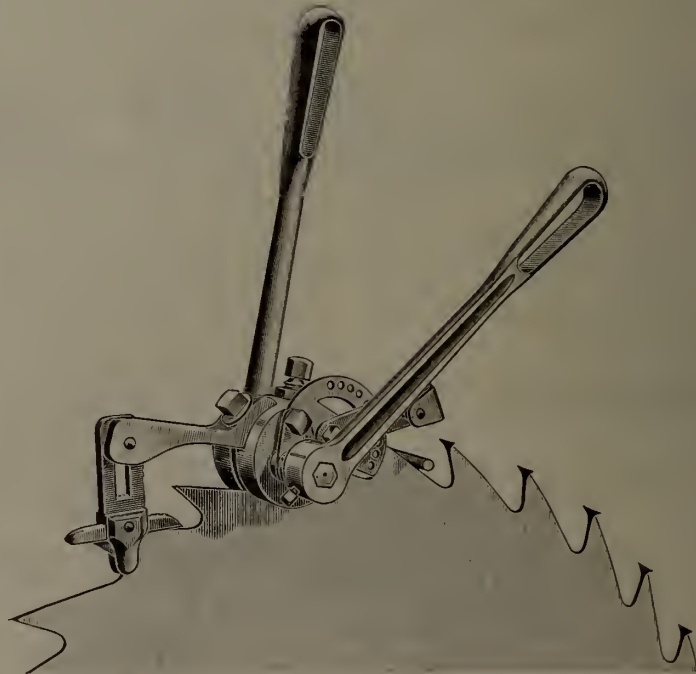

We make nothing but Saw Swages and use the finest material obtainable in manufacturing.

Let me send you reference of some who have used them.

D. J. CROWELL, 200 The Terrace,
BUFFALO N. Y.

Cost of Lubrication reduced 30 to 50 per cent.

Read following Testimonials for Proof.

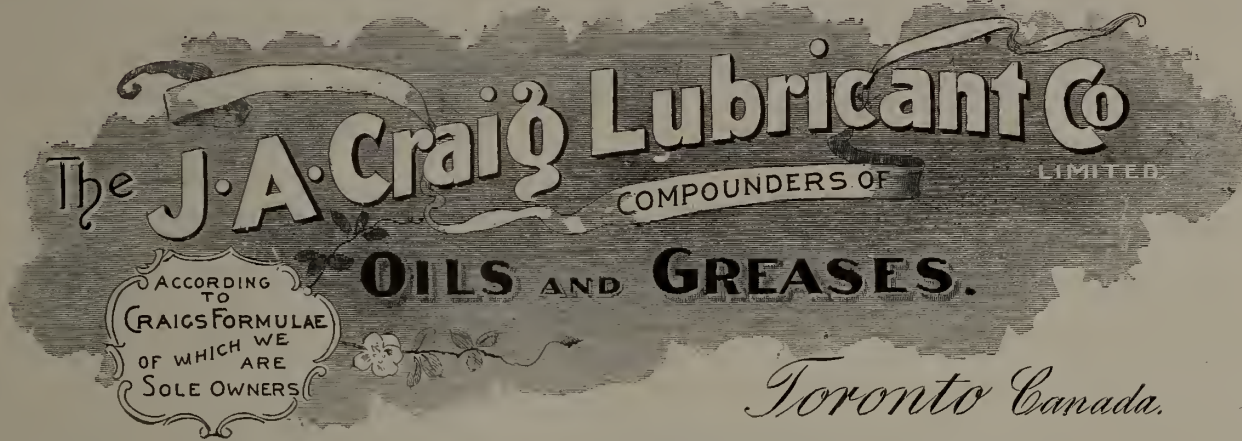

We Can do the same for You

TORONTO, October 24th, 1904.

THE J. A. CRAIG LUBRICANT CO., Limited,
Toronto, Ont.

GENTLEMEN,—It is with great pleasure we testify as to the practical value of your Cylinder and Engine Oils, also your compounded greases, as your goods have certainly been a surprise to us.

We adopted your system of lubricating at our mills and on our boats at French River for the season of 1904 and on comparing this year's accounts to date we find you have reduced our oil and grease account to one half what it has been in former years, and this in the face of additional machinery recently installed and the output of our mills having been greatly increased.

Not once during the whole season have we been troubled with a hot journal, our first experience of this sort in years.

We have one man only to do the oiling for our entire plant and he appears to have an easy time.

So long as you continue to supply us with goods equal to what we have had from you this season, you can depend upon receiving all of our trade in this line.

You are at liberty to make use of this letter in whatever way you wish, as we really feel grateful for what you have done for us at our mills.

Yours truly,
THE ONTARIO LUMBER CO., Limited.
H. H. Cook, President.

BYNG INLET, AUGUST 13TH, 1904.

MR. J. A. CRAIG:

Dear Sir, or to whom it may concern,—I have been using your cylinder oil on our 600 horse Corliss Engine in our saw-mill as a test for the last three weeks and I can honestly say I can run on less oil than half and with better results than with any other oil I have ever tried, in fact the metal is so soft in this engine no kind of cylinder oil (Vacuum included) we could buy in Canada would do. The only oil we could use was Harris Oil imported from Boston, U. S. A.

The longest a one gallon lubricator of Harris Oil would run was seven hours, while your cylinder oil would run twenty-one hours with better results. I tried the oils in our other big Corliss with even better results, and as long as you compound your cylinder oils and have them as good as samples I shall use no other.

Your compression cup grease is excellent and your pure fat for enriching mineral oils makes everything run safe. I therefore highly recommend them.

Yours truly,
JAMES TATE,
Chief Engineer Holland & Graves Lumber Co.
Byng Inlet, Ontario.

We Are Headquarters for Engine Packings, Pipe and Boiler Coverings Etc., Etc., Etc.

Cling Surface
for
Belts and Ropes

Smooth-On
for
Iron Repairs



Asbestos
in all its forms

Insulating
Materials
and Papers

Paroid, Vulcanoid and Red Rope Ready Roofing

EUREKA MINERAL WOOL AND ASBESTOS CO. TORONTO

PERSONAL.

Mr. M. Knowlton, a former lumber merchant of London, Ont., but now of Willimantic, Conn., was recently on a visit to his old home.

Mr. S. McBride, wholesale lumber merchant, Toronto, was a successful candidate for Aldermanic honors in Ward 3 at the municipal elections on January 2nd.

Mr. A. B. Cowan, president of the Cowan Company, manufacturers of woodworking machinery, Galt, Ont., recently visited British Columbia to investigate the possibilities of extending their trade in that province.

A donation of \$15,000 has been made by Mr. E. C. Whitney, of the St. Anthony Lumber Company, Ottawa, to the Trustees of Toronto University, the money to form the nucleus of a residential building for the University.

Mr. C. H. Waterous, president of the Waterous Engine Works Company, has been chosen Mayor of the City of Brantford for the year 1905, a position for which he is well qualified by his extensive business experience and large local interests.

Mr. Jeremiah Finch, one of the foremost Adirondack

land owners and a lumber merchant known throughout the state, died at his home in New York city on December 16th last, in his seventy-four year. Two years ago, as the result of overwork, he suffered a stroke of paralysis, from which he never fully recovered.

Mr. Joseph Oliver, president of the Oliver Lumber Company, wholesale lumber dealers, Toronto, was a candidate for a seat on the Board of Control of the City Council, and although polling a large vote, was unsuccessful. Mr. Oliver has previously served on the Board and would have been a useful member if elected.

Heretofore the Canadian Section of the Imperial Institute, London, England, containing samples of Canadian products, besides being a bureau of information, has been in charge of Mr. Harrison Watson. Recently a change was made by which Mr. Watson was placed in charge of the newly established "city trade branch of the Canadian government offices," in Basinghall street, which are under the jurisdiction of the High Commissioner.

Mr. Ormsby J. Donogh, secretary and manager of the Imperial Lumber Company, Toronto, returned last

month from a visit to Great Britain. He reports a material improvement in the conditions affecting the lumber trade in the United Kingdom. Mr. J. G. Spence, who was formerly vice-president of the McGillivray Lumber Company, of Ottawa, accompanied Mr. Donogh and remained in England to assist Mr. L. A. Grant in the management of the Manchester office of the Imperial Lumber Company.

CALENDARS RECEIVED.

The CANADA LUMBERMAN has received many attractive calendars for the new year. The Imperial Lumber Company, of Toronto, are favoring their friends with one of large size showing some excellent lithographic views of lumber scenes. That bearing the compliments of Keenan Bros, wholesale lumber dealers, Owen Sound, Ont., has a pretty girl as the central figure. The American Wood-Working Company, New York; West & Peachy, manufacturers of alligators, Simcoe, Ont.; the Long-Knight Lumber Company, Indianapolis; the Waterous Engine Works Company, Brantford, Ont., and the Haviland Lumber Company, New York, have gotten out splendid calendars.

The Boiler Inspection & Insurance Co.

Of Canada

JOHN L. BLAIKIE, President
E. WALTER RATHBUN, Vice-President

Canada Life Building, TORONTO

GEO. C. ROBB, Chief Engineer
H. N. ROBERTS, Secretary

THIRTY YEARS EXPERIENCE AS CONSULTING ENGINEERS

Cache Bay, Ont., October 17th, 1904.

THE BOILER INSPECTION & INSURANCE CO.
OF CANADA,

Toronto, Ont.

We take pleasure in certifying that the engineering services given with one of your Policies of Boiler Insurance fully repay any outlay in the shape of premium, and at the same time furnish a feeling of security against accident by explosion.

In short, these engineering services have given us the best of satisfaction.

Yours truly,
GEO. GORDON & CO.

Toronto, 21st November, 1903.

THE BOILER INSPECTION & INSURANCE CO.
OF CANADA.

Toronto, Ont.

Dear Sirs:—

We beg to acknowledge receipt of your favor of 20th inst. enclosing cheque for \$6500. in full payment of loss under your Policy No. 9131 caused by the explosion of our boiler three days ago. Also of your favor of 19th inst. enclosing cheque for \$650. being the additional insurance on the lives of the Engineer and Fireman who were killed, payable to us, under the policy, for their representatives.

Assuring you of our high appreciation of your prompt and satisfactory settlement of this loss. We are,

Yours truly,
UNITED FACTORIES, LIMITED,
per Emil C. Bockh, Pres't. & Gen'l Manager.

Toronto, October 17th 1904.

THE BOILER INSPECTION & INSURANCE CO.
OF CANADA,

Canada Life Building,
Toronto, Ont.

Gentlemen:—

We have much pleasure in signifying our very high appreciation of the valuable engineering services rendered to us by you during the period our boilers have been insured.

We consider that any of your Policy-holders who choose to take advantage of services that are practically free to them, will receive far more than full value for the premiums paid by them.

Personally we cannot speak too highly of the advantages we have derived from your advice on several occasions, advice which has been the means of saving us considerable money.

Yours truly,
THE ONTARIO LUMBER CO., LIMITED
H. H. Cook, President.

Thorold, Ont., October 24th, 1904.

THE BOILER INSPECTION & INSURANCE CO.
OF CANADA,

Consulting Engineers,
Toronto, Ont.

Dear Sirs:—

In justice to your Boiler and Insurance Company would say that we cheerfully acknowledge that we are well satisfied to continue placing the risk with you on our nine Saw Mill Boilers at Little Current, on the same terms as during the past three years.

You cheerfully give us your valued opinion and advice on all matters affecting the Boilers and Engines in our Mill and knowing your ability, from long experience in such matters we have no hesitation in advising others to insure their boilers with you.

Yours truly,
J. & T. CONLON.

Toronto, October 21st, 1904.

THE BOILER INSPECTION & INSURANCE CO.
OF CANADA,

Toronto, Ont.

Dear Sirs:—

In 1902 we secured a policy in your company on the boilers in our Mill at Spragge, and altho we installed an entirely new Battery last winter we are still keeping up our Insurance as we feel convinced that the assistance and advice we get from you is fully worth what we pay you for our Insurance apart from the feeling of security against accident by explosion.

Yours truly,
THE COOK & BROTHERS LUMBER CO.
LIMITED.

Byng Inlet, Ont., October 29th, 1904.

THE BOILER INSPECTION & INSURANCE CO.
OF CANADA,

Toronto, Ont.

We are pleased to express our appreciation of the policy we have in your Company, giving insurance on our Boilers and at the same time the inspection made regularly by your competent Engineers which affords protection as far as possible against explosions.

The Premium charge is only nominal considering services rendered.

Yours very truly,
HOLLAND & GRAVES
per W. E. Bigwood.

INSPECTORS

O. P. ST. JOHN, TORONTO
F. W. DONALDSON " "
A. E. EDKINS " "

GEO. FOWLER, TORONTO
A. P. ROBB " "
J. E. C. BOYCE " "

OLAF. E. GRANBERG MONTREAL
A. GEORGES CHAMPAGNE " "
A. M. BONNYMAN, AMHERST, N. S.

OUR SPECIALTIES ARE
 MARINE ENGINES
 MARINE BOILERS
 ENGINES for Stern Wheel Steamers
 HYDRAULIC DREDGES

SEND FOR CATALOGUES

THE DOTY ENGINE WORKS CO.,
 LIMITED
GODERICH, ONT.

Branch Office at Toronto

CABLE ADDRESS: TURNERS, PETERBOROUGH, CANADA

J. J. TURNER & SONS

CORNER GEORGE, KING @ WATER STREETS. Electric Cars Pass Our Door.

MANUFACTURERS OF

LUMBERMEN'S GOODS

Tents, Waterproof Goods, Horse Covers, Wagon
 Covers, Clothing, Pack Sacks, Horse Blankets,
 Rugs, Surcingles, Coal Bags, Feed Bags, Etc.

ORDERS PROMPTLY FILLED.

Long Distance Phone, 180a, 180b, 195 Day or Night.

TRAMWAY EQUIPMENT

RAILS, CARS AND LOCOMOTIVES

NEW AND SECOND HAND

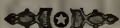

JOHN J. GARTSHORE

83 Front Street West, TORONTO.

THE RIDER & KITCHENER CO., Limited

Lindsay, Ont., Can.

MANUFACTURERS

Excelsior Brush Handles and
Blocks, Turned Goods

ALSO



Rotary Cut Plain Veneers in
Birch, Basswood, Elm and
Ash.

The **MIDLAND**
BAND MILL GRINDER

— IS THE —

**SIMPLEST, MOST EFFECTIVE
GRINDER EVER DESIGNED.**



After this machine
 has been once in
 position on your saw
 frame, it can be plac-
 ed in position ready
 for grinding in thirty
 minutes.

ONE SETTING GRINDS BOTH WHEELS

Thus ensuring perfect alignment.

Write for particulars to . . .

GEORGIAN BAY ENGINEERING WORKS

MIDLAND

ONTARIO

Our knowledge of River Navigation is earned through long experience and ex-
 ceptional opportunity. We design the boat and build the ENTIRE AND COMPLETE
 outfits of driving machinery and fastenings for powerful light draft vessels,
 for boat-builders and those putting up their own hulls. Have the best of
 shop facilities to aid us in doing **ALL** the work. Write to us before you act.

CATALOGUE FREE.

MARINE IRON WORKS

STATION A. 233 W

CHICAGO, U. S. A.



JOHNSON'S VETERINARY REMEDIES

Are Still the Leaders with the
Lumbermen of Canada . . .

They consist of :—

JOHNSON'S VETERINARY HEALING OINTMENT AND CALL CURE

Put up in $\frac{1}{4}$ lb. and 2 lb. tins. The best all-round healing ointment on the market. It cures galls, wounds, scratches, corks, cuts, sore-shoulders, etc., etc. It is cleansing, antiseptic, healing and drying. Sample tin mailed on request. Regular 2 lb. tins, \$2.25 each.

JOHNSON'S HORSE LINIMENT NO. 1 [Alcoholic]

Put up in 1 gall. jugs, \$4.50 gallon. The cheapest and most effectual liniment on the market, can be applied wherever the use of a liniment is indicated.

JOHNSON'S HORSE LINIMENT NO. 2 [Oils]

Put up in 1 gall. jugs, \$3.00 per gallon. This is a most useful liniment, but lacks the penetrating qualities of the No. 1.

JOHNSON'S HORSE COLIC REMEDY

Put up in 1 gall. jugs, \$5.00 per gallon. This is a sure and speedy also a safe cure for colic in Horses or Cattle.

These goods being put up in bulk are much cheaper than any other lines, the cost of bottles, boxes, cartons and of bottling and boxing being saved. A full line of all kinds of medicines for the stable and camp vans always on hand at lowest possible prices. Write for list. 10% Trade Discount off all orders amounting to \$50.00 and upwards.

Correspondence Solicited.

A. H. JOHNSON,
Wholesale Druggist,
COLLINGWOOD, ONT.

JAS. LEIGH & SONS

MANUFACTURERS OF AND DEALERS IN

**SPRUCE
CEDAR AND
FIR
LUMBER
SASH and DOORS**

Finish and Mouldings, Turnings and Brackets, Etc., Etc.

CAR ORDERS SOLICITED

VICTORIA - BRITISH COLUMBIA

TAYLOR & CO. —
ALL KINDS OF . . . KAMLOOPS, B.C.

ROUGH AND DRESSED LUMBER, SHINGLES, ETC.

SAWMILL NEAR THE OLD BRIDGE, KAMLOOPS

Correspondence Solicited



The "Alligator" Steam Warping Tugs
SIDE WHEELS OR TWIN SCREWS

The Twin Screws are arranged with flexible joint to
raise up in crossing portage

MANUFACTURED BY

WEST & PEACHEY, - Simcoe, Ont.

Cables carried in stock for renewals

THE TOWER ONE MAN 2-SAW TRIMMER.

With this celebrated trimmer one man can easily trim the output of a mill cutting up to 30,000 ft. in ten hours. We also make a larger and heavier machine of the same description, for mills cutting up to 50,000 feet in the same length of time.

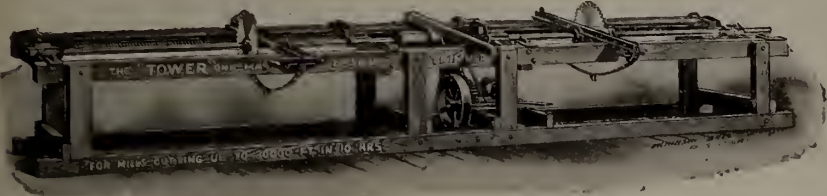

The manner of adjusting the saws
SAVES TIME, SPACE AND LUMBER.

The crank for shifting the saws is carried by one of the transfer blocks, instead of being at one end of the machine as is customary. This construction (i. e., the one employed by us) has two distinct advantages over the ordinary arrangement.

They are:

1. There is a great saving of **time and labor**, especially with **short boards**. With other trimmers, it is necessary to go to the **end of the machine** every time the saws are shifted. With ours, it is **never** necessary to go beyond the **end of the board**. The result is a great saving in the **number of stops** taken, and an increase in the **quantity of work** done.

2. With our machine, the operator, traveling as he does with one of the transfer blocks, is in a position to see **instantly** how to trim a board to the **best advantage**, which he could not do from the end of the trimmer. This often means a **saving of lumber** by reducing waste.

There are two feeds, which can be started, stopped or changed while the saws remain in motion.

We also manufacture the
GORDON HOLLOW BLAST GRATE
and
TOWER and TOWER EXTRA Edgers.

The Gordon Hollow Blast Grate Co., Greenville, Mich.
ESTABLISHED 1889.

The largest manufacturer of Blast Grates, Edgers and Trimmers in the world.
SEND FOR CATALOGUE D.

RUBBER BELTING

For
Transmitting
Elevating
and
Conveying



Rubber
Hose
for
Water
Steam
Air
Suction
Fire
Protection

THE GUTTA PERCHA & RUBBER MFG. CO.
OF TORONTO, LIMITED.

TEMPORARY OFFICES: 15 EAST WELLINGTON STREET, TORONTO, CAN.

Branches: Montreal, Winnipeg.

THE CLAY DRY KILN CO. Contract and Build STEAM OR RARIFIED AIR KILNS.

SALES AGENT WANTED FOR CANADA ON COMMISSION.



RAISTON, MISS.,
Dec. 8, 1902.

We wish to say that your kiln is giving perfect satisfaction and we are confident it is the best kiln made. We dry our lumber in three day thoroughly, with a heat 160 to 180 degrees, and if this heat is kept regular it will not check the lumber.

Yours truly,
ENON LUMBER COMPANY
Per R. B. Draughn.



INTERIOR VIEW OF CLAY DRY KILN. (Canadian Patent No. 88835.)



ELDER, MISS.,
Jan. 8, 1903.

To whom it may concern:
This is to certify that we have been using the Clay dry kiln for five months and find it does the work satisfactorily. We have a kiln 20 feet by 100 feet and will dry from 10 to 15 M daily. One of these kilns properly built and properly handled will give perfect satisfaction.

Very truly yours,
HELENA LUMBER COMPANY.

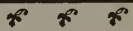

The cut shown above represents a desirable construction which forms the subject of a Patent issued to L. C. Van Duzer, adapted to facilitate the drying of Clay products and lumber, &c., by means of heated air. The furnace is located at the end where the green Lumber enters the kiln, and is enclosed inside of the air furnace, where the cold air is admitted. The air passes around the furnace into several conduits and is conducted to the end of the kiln where the dry stock is removed. The RARIFIED air passes through the green material absorbing the moisture, and then passes out through the air stack. The perfect circulation of the RARIFIED air is a superior advantage in drying Lumber, and is the reason that the Clay Dry Kiln is superior to all others. It is guaranteed to perfectly season Pine Lumber in 52 hours. If interested address

CLAY DRY KILN CO., HATTIESBURG, OR ROOM 703, HOUSER BUILDING, ST. LOUIS, MO.

PURE MANILA ROPE

Highest Quality Made

BRITISH MANILA

SISAL ROPE

Pure Sisal

LATH YARN

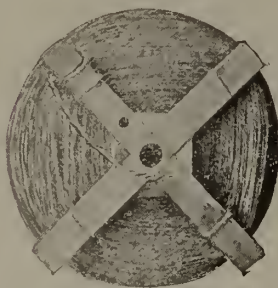

Wire, Write or Phone

Canadian Cordage & Mfg. Co.

Long Distance Phone 162

PETERBOROUGH, ONT., CANADA

Limited

Our Rope and Lath Yarn are Recognized as the Best on the Market

KILLAM'S PATENT TANDEM CIRCULAR SAW MILL

THE Tandem Circular Mill supplied by M. L. Killam to the Grand River Pulp and Lumber Company has been running the past season at Gillisport, Labrador. It makes the lumber as true to thickness as a gang. I assure you that if one saw mill in the ordinary ten hour day cut forty thousand superficial feet deals and boards, it is no trouble to cut sixty-five thousand with the Tandem. We made an average of sixty thousand the past season, and if we had had a sawyer who understood his business would have cut much more. I heartily recommend the Tandem.

J. A. GILLIS, Manager.

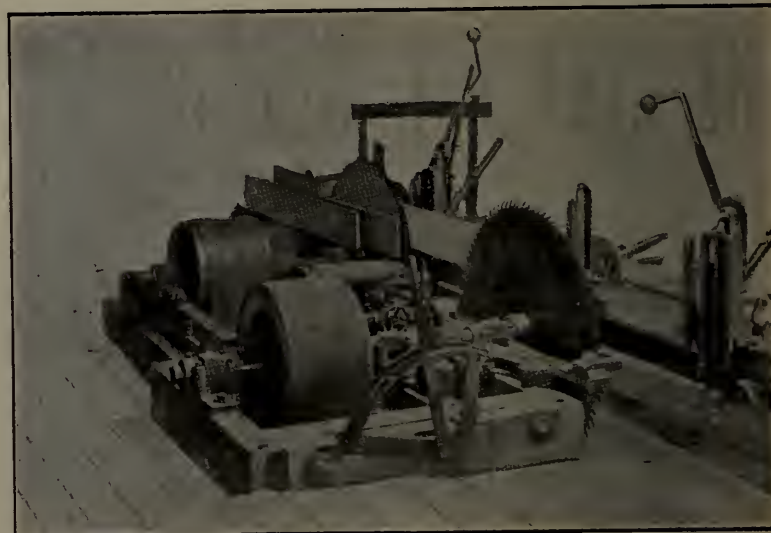

KILLAM'S PATENT AUXILIARY SAW GUIDE AND SELF ADJUSTING SET COLLARS

FOR CIRCULAR SAW MILLS

THIS is what Mr. Alfred Dickie, of Lower Stewiacke, N. S., says: "I have been using your Patent Auxiliary Saw Guide and Self Adjusting Set Collars in several of my mills and find them satisfactory in every respect. I also got your Patent Tandem Circular installed in several of my mills, and intend to increase the cutting capacity of some of my other mills by having it put in, as it has given every satisfaction.

A. DICKIE.

For Further Particulars and Prices Address the Manufacturer

M. L. KILLAM, Truro, Nova Scotia



MADISON WILLIAMS,

SUCCESSOR TO

PAXTON, TAYE & CO.
Founders and Machinists.

WORKS
PORT PERRY.

"VULCAN"
"PERFECTION"
AND
"LEFFEL"
TURBINE
WATER
WHEELS

LANE CIRCULAR
SAW MILLS,
SHINGLE
MILLS,
GRINDING MILLS,
BARK MILLS,
&c. &c.

CANADA
ONTARIO

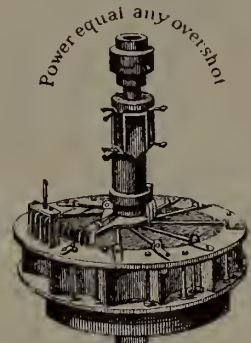
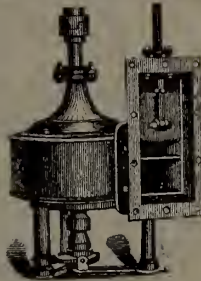

Port Perry, Ont. Jan. 13th. 1904.

The C. H. Mortimer Publishing Co.,
 Toronto, Ont.

Dear Sirs;-

We have at hand yours of the 12th. inst. In reply beg to say that you will find enclosed renewal advertisement contract, duly signed. We might say that we find "The Lumberman" a good medium for reaching our constituency. We are,

Yours truly,
MADISON WILLIAMS
 per *NB*

B. R. MOWRY & SONS, GRAVENHURST, ONT.

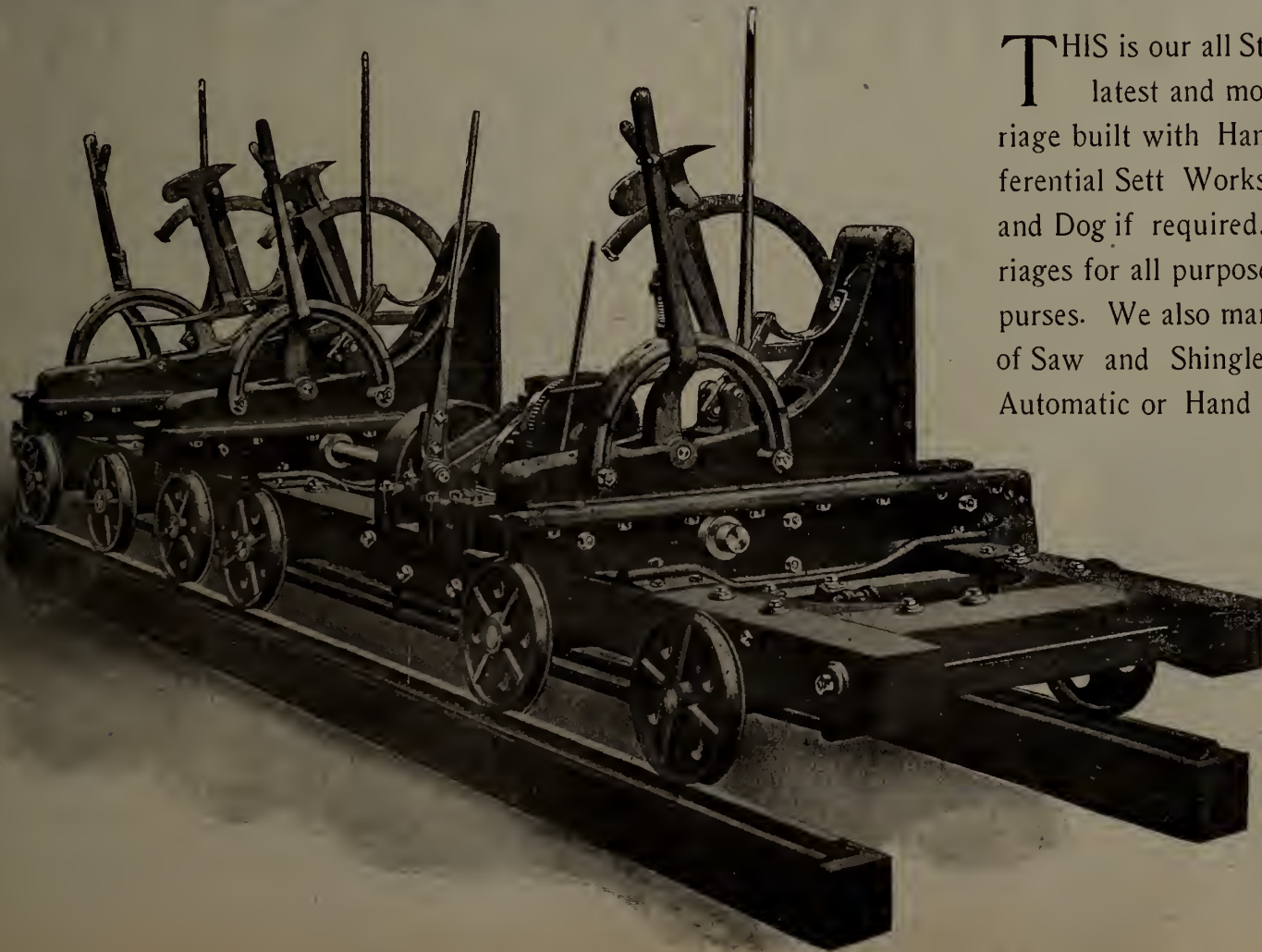

THIS is our all Steel Carriage. The latest and most up-to-date carriage built with Hammer Dogs. Differential Sett Works and Steam Sett and Dog if required. We build carriages for all purposes and to suit all purses. We also manufacture all kinds of Saw and Shingle Mill Machinery, Automatic or Hand Filing Machinery for the care of saws. All kinds of automatic and semi automatic Castings in iron or Brass. Write for quotations.

✻ ✻
B. R. MOWRY
& Sons,
 Gravenhurst, Ont.

NEW IMPROVED HORIZONTAL BAND RESAW



The only resaw in the world that will successfully resaw slabs, lumber or timber. Carries an 8" saw, and will handle stock 12" thick and 36" wide. Weight, 19,000 lbs. We make smaller sizes also.

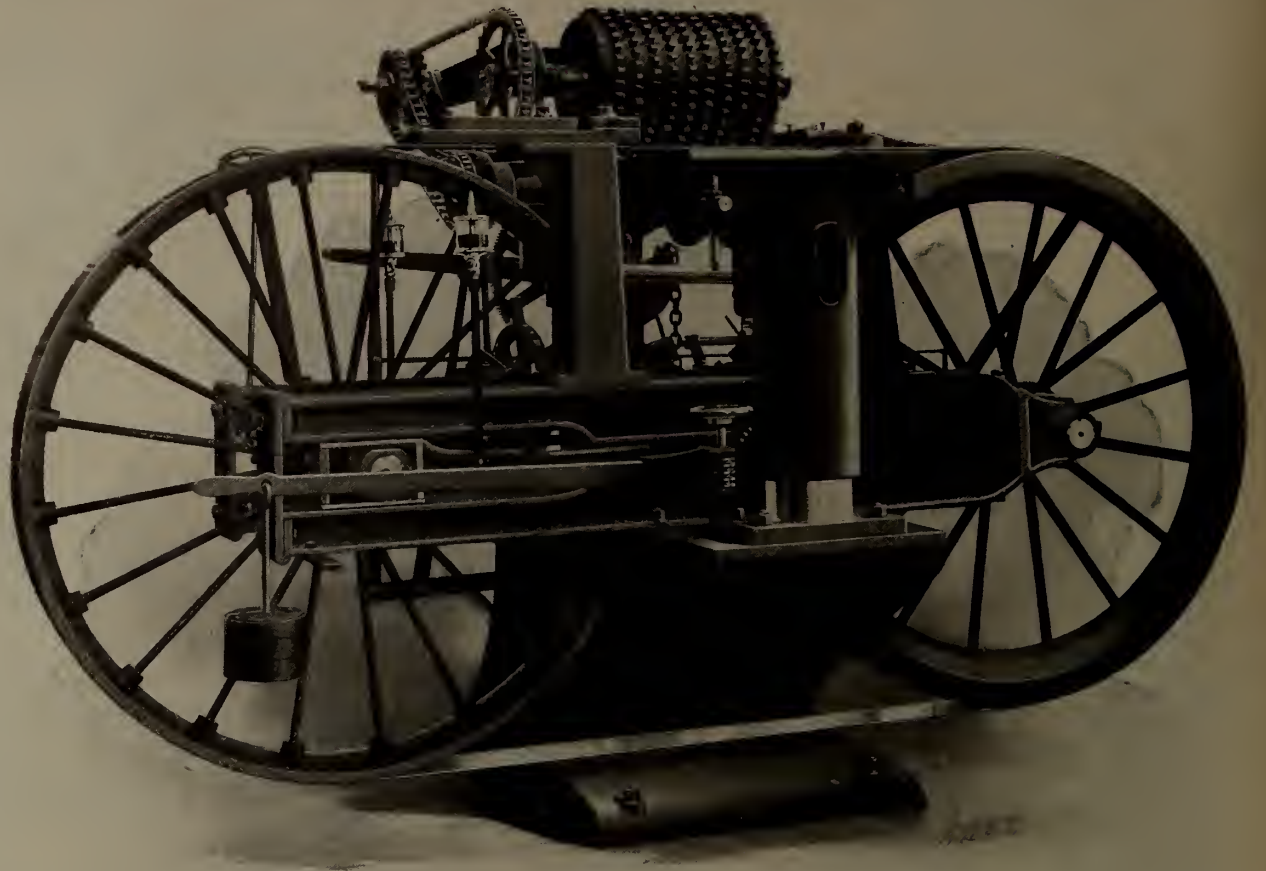

Giddings & Lewis Manufacturing Co., Fond du Lac, Wis., U.S.A.

THE TRIUMPH TURBINE



Is the most powerful wheel on the market to-day. A glance at this cut of the centre shows that the buckets are designed to secure the **maximum of speed** with **great power** and a **free discharge**. Mr. E. S. Edmondson, of Oshawa, writes as follows under date of November 16th, 1903, regarding a 26 inch Vertical Triumph Wheel:

"The Wheel is strictly first-class in every particular, and after a careful and thorough test I am prepared to say that I believe it is the best wheel in the market for Electrical purposes. It has high speed, large power, high efficiency at part gate, and has practically no leakage. I am more than pleased with the thorough and workmanlike setting you gave me throughout."

For horizontal settings in large Pulp Mills, Cement Mills or Electric Power Developments this Wheel has no equal. We invite your enquiries. Large catalogue to be had for the asking.

We are always glad to submit estimates and prices on **Improved Vulcan and Leffel Turbines, Improved Lane Circular Saw Mills, Edgers, Trimmers, Slashers, Shingle Machines, Lath Machines** and all machinery of this kind.

MADISON WILLIAMS

H. E. PLANT, Agent
Cor. Common and Nazareth Streets
Montreal, Que.

Successor to Paxton, Tate & Company
PORT PERRY, ONT.

Manitoba Iron Works
Western Selling Agents
Winnipeg, Man.

THE DISTINGUISHING MARK



Factories and Home Office,
Indianapolis, Ind.

To install in your mill a set of saws that will suit you in every particular, it is necessary that you be familiar with some means of distinguishing the HIGH-CLASS SAWS from the others. Knowing some such mark you will always discriminate in favor of the saw which bears that mark of QUALITY.

THE ATKINS "TRIPLE A" etched on all HIGH GRADE SILVER STEEL CIRCULAR and BAND SAWS, is the sign which assures QUALITY, EXCELLENCE and absolute SUPERIORITY in Saws. "IF IT'S SILVER STEEL IT'S AN ATKINS." Look for our trade mark.

A little reminder of the "TRIPLE A" in the way of a pretty watch charm to Mill men who write for it. Also our Mill Supply Catalogue. Both free.

E. C. ATKINS & CO., Inc.



Canadian Branch,
30 Front St. East, Toronto, Ont.

Saw Mills

Portable and Stationary

Mill Dogs, Edgers and Mill Supplies
High Grade Portable and
Stationary Engines and Boilers

SEND FOR CATALOGUES

The Robt. Bell Engine & Thresher Co., Limited
SEAFORTH, ONT., CAN.

HUTHER BROS. PATENT GROOVER OR DADO HEAD

For cutting any width groove from 1/4-inch to 2 inches or over

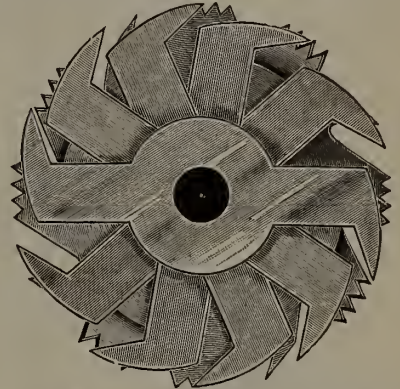

Can be used on any Circular Saw Mandrel.

Will cut a perfect groove with or across the grain.

This is the only Dado Head on the market that gives entire satisfaction on all classes of work. No screw adjustment. For different width grooves, simply remove or add inside cutters. Sold by builders and dealers of woodworking machinery in all parts of the United States. Will send on approval, in competition with any other make on the market; if not the best return at our expense. HUTHER BROS., Platt Street, ROCHESTER, N.Y., manufacturers of Circular Saws, Morgan Pattern Lock-Corner Box Cutters, Concave Saws, etc.

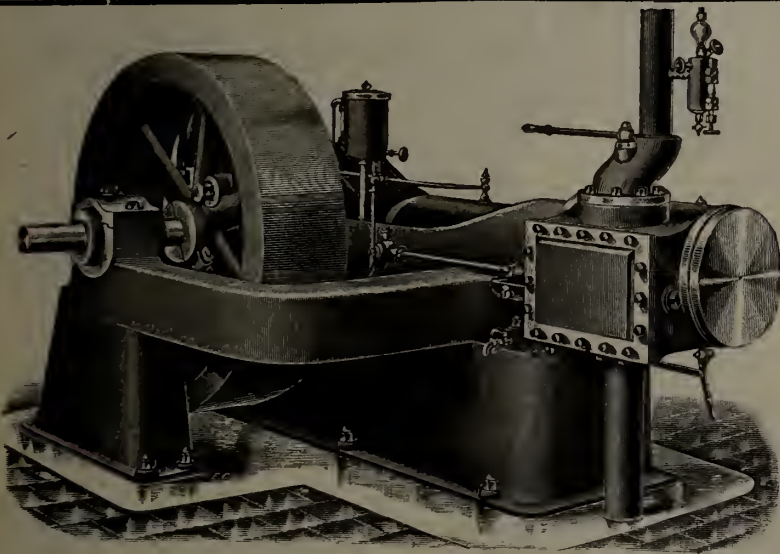

GIVES NO TROUBLE

A mill owner writes us: "The 16x16 Robb-Armstrong Automatic Engine installed in our saw mill in 1903 has proved very satisfactory. It has been running steadily five months each sawing season of 1903 and 1904 and has given us no trouble whatever. We drive with it a large rotary, lath mill, patent haul-up, complete sawdust conveyor throughout the mill, live rolls, trimmers, slab saws and planers. We do not have to develop its full power to do this work. The governor is very sensitive, there being only a variation of 3 per cent. when saw is running in and out of cut. We use steam feed to drive our rotary and put through the mill 750 to 800 logs per day."

ROBB ENGINEERING CO Limited, Amherst, N.S.

Agents: { William McKay, 320 Ossington Avenue, Toronto.
Watson Jack & Company, Bell Telephone Building, Montreal.
J. F. Porter, 355 Carlton Street, Winnipeg.

IN OUR LINE WE LEAD

McFarlane Patent Wrot Forged Steel Socket Cant Dogs

Leads them all

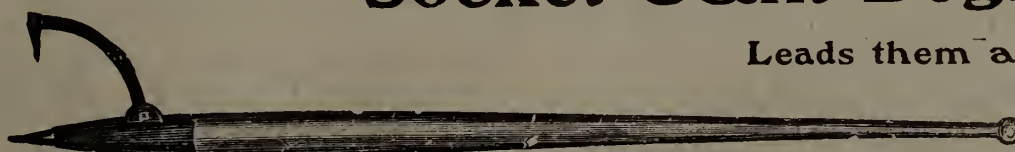

Used in every Lumbering District from the Atlantic to the Pacific Ocean

Extra Fine Quality Split Rock
Maple Handles

Round and Duck Bill Peaveys and
Cant Hooks

Write for quotations. If once used you will never return to the old malleable sockets.



Detachable Chain Belt

—AND—

CONVEYING

MACHINERY



William R. Perrin & Company
Limited
TORONTO, CANADA.

A. F. BARTLETT & CO.

Manufacturers of and Dealers in

Engines, Boilers Saw Mill Machinery

Etc.

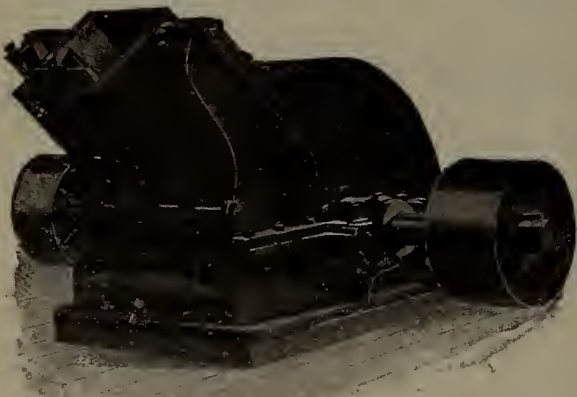

This is
our Saw
Mill Hog
or
Edging
Grinder

If you have no Hog write us for circulars and let us tell you all about ours. They save their cost in a short time. Write for our Stock List of New and Second Hand Machinery.

A. F. BARTLETT & CO. Saginaw, Mich.

FRANK DENTON, K. C. HERBERT L. DUNN
W. MULOCK BOULTBEE.

DENTON, DUNN & BOULTBEE
Barristers, Solicitors, Notaries, etc.
National Trust Chambers. TORONTO

OILS

Manufacturers High-grade Cylinder, Machine and Sawmill Oils.

Calypsol Grease

for Sawmill Purposes a Specialty. Our products are made from finest Pennsylvania stocks.

We solicit your correspondence.

St. John St., MONTREAL. Commercial Oil Co.,
Offices and Works : Manchester, Eng. Hamilton, Ont.
Hamburg, Germany. Newark, N. J. Chicago, Ill.

—IMHAUSER'S—

Watchman's Time Detectors That Cannot Fail.

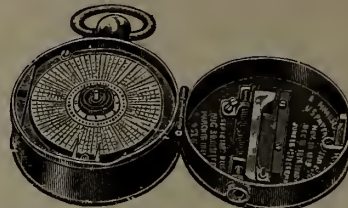

Contain all the modern improvements. Warranted in every way. Cannot be tampered with without detection. Manufactured by

E. IMHAUSER & CO., 206 Broadway New York.
Write for Catalogue. Highest Award Pan-American Exposition

Please mention this paper when corresponding with advertisers.

SHERMAN'S FLOORING MACHINES

PATENTED

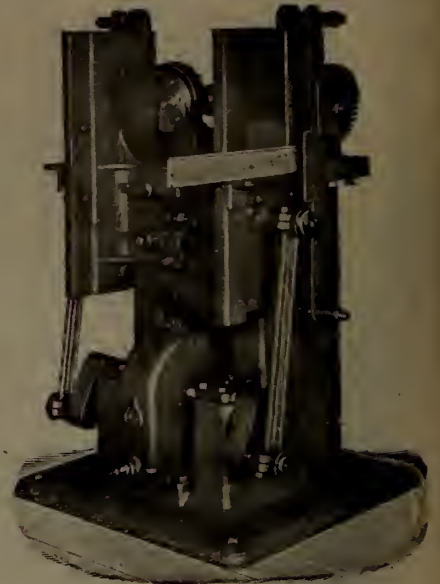

Above cut shows our End Matcher, the best machine in the market for end matching flooring strips. They do rapid and accurate work, and are durable—therefore used by leading flooring manufacturers. Make your flooring profitable by end matching it.

We Make the

SHERMAN SIDE BORING MACHINES

and the

SHERMAN FACE BORING MACHINES

To bore flooring while it is being run on the flooring machine. Write for circular and list of users.

W. S. SHERMAN CO.

1150 Holton St., Milwaukee, Wis.

WOODWORKERS SAY

"The convenience to the Sawyer and the saving in lumber make the **STANDARD AUTOMATIC SAW GAUGE** an article of much merit."

WRITE TO
SPECIALTY MFG. CO.
DETROIT
Mich.

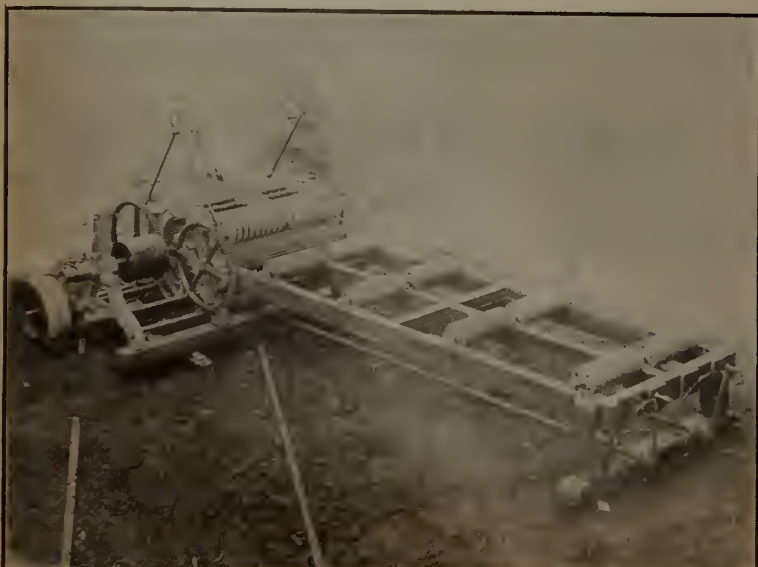

OXFORD FOUNDRY AND MACHINE CO. OXFORD, N. S.

OUR SPECIALTY IS

SAW MILL MACHINERY

We Have Filled Orders from the Pacific Coast of B. C. to Labrador. * * *

WRITE AND LET US GET ACQUAINTED

THE A.J. BURTON SAW CO.

LIMITED
Vancouver, B. C.

Inserted-tooth, Shingle- and Band

SAWS

File-room Machines and Tools,
Emery Wheels,
Silver Solder, etc.

BITS AND SHANKS

BRITISH COLUMBIA AGENTS FOR R. HOE & CO.

REPAIRS executed promptly by expert workmen.
INSERTED-TOOTH SAWS REMILLED & REFITTED.

WE ARE HERE ON THE GROUND.

SAVE FREIGHT AND DUTY
TRY US.



A Millstone About the Neck

Lack of special training is the "millstone about the neck" of most carpenters and wood workers in poor paying positions. It holds them back while others go ahead. It handicaps them everywhere. The International Correspondence Schools' system of training by mail will enable you to throw off the burden. By this method thousands of ambitious carpenters and wood workers have been able to advance in place and salary. Many have been able to change their occupation, taking positions in their chosen profession. We enable young people to commence work at better salaries than if they started without training.

The accounts of the rise of some of our students read like romance. Many have risen from the lowest to the highest positions in their calling.

Decide today to better your condition—then let us help you. What we have done for others we can do for you.

Mark X before the position that interests you, fill in the coupon and send it to us. We will send you full particulars.

INTERNATIONAL CORRESPONDENCE SCHOOLS

Box 1001, Scranton, Pa.

Please send me your booklet, "1001 Stories of Success," and explain how I can qualify for the position before which I have marked X.

Architect	Sanitary Engineer
Architectural Draft'g	Chemist
Contractor & Builder	Ornamental Designer
Building Inspector	Bookkeeper
Mechanical Engineer	Stenographer
Mechanical Drafts.	Show-Card Writer
Electrical Engineer	Ad Writer
Dynamo Tender	French } With
Telephone Engineer	German } Phono-
Steam Engineer	Spanish } graph
Civil Engineer	Commercial Law
Surveyor	Civil Service Exams.

Name _____
St. & No. _____
City _____ State _____

The Shimer Gutter Heads WITH EXPANSION

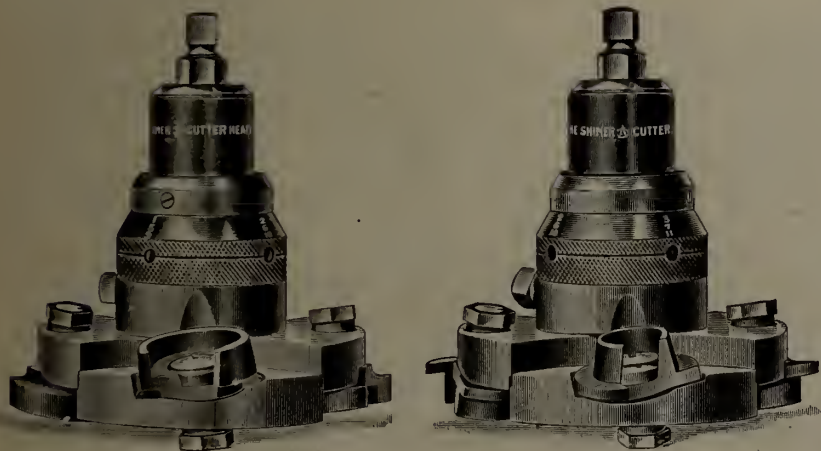

Are built from forgings of Steel and finished throughout in the solid metal. This insures accuracy, durability and perfect mechanical adjustments.

They are appreciated by the user because they hold up under the severest tests. They cut easily all kinds of hard, knotty and cross-grained lumber. If you make single tongue and groove Flooring, Ceiling and Wainscoting, buy THE SHIMER CUTTER HEADS and you will have no disappointment. Address

SAMUEL J. SHIMER & SONS
Milton, Pennsylvania

THE BEST IN THE WORLD

There is no doubt about the fact that the

RODGERS

Adjustable Log Siding Machine

is without a peer.

This machine will slab opposite sides of a log in one operation at the rate of two thousand logs in 10 hours.

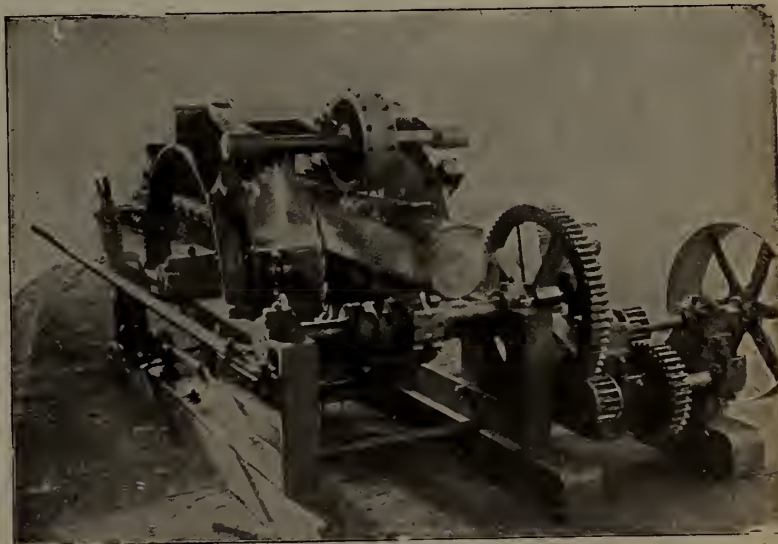

A MONEY MAKER

A MONEY SAVER

HUNDREDS OF LETTERS RECEIVED LIKE THIS :

Rock Island, Ill., Nov. 25, 1902.

RODGERS IRON MANUFACTURING CO., Muskegon, Mich.

Gentlemen:—Replying to yours of recent date and referring to your adjustable log siding machine, must say it has given us general satisfaction, and we have done good work with it. Any one desiring a machine of this style for the purpose of slabbing small logs, we would recommend yours.

Respectfully,

WEYERHAUSER & DENKMAN.

For full particulars and literature, mention this paper and address :

RODGERS IRON MFG. CO.
MUSKEGON, MICH.

THE DYMENT FOUNDRY CO.

BARRIE, ONT.

Manufacturers of

ENGINES, BOILERS, STEAM FEEDS

AND A COMPLETE LINE OF

SAW, SHINGLE AND
LATH MILL MACHINERY

Can ship mills in a week's notice. Write us
for prices and catalogue.

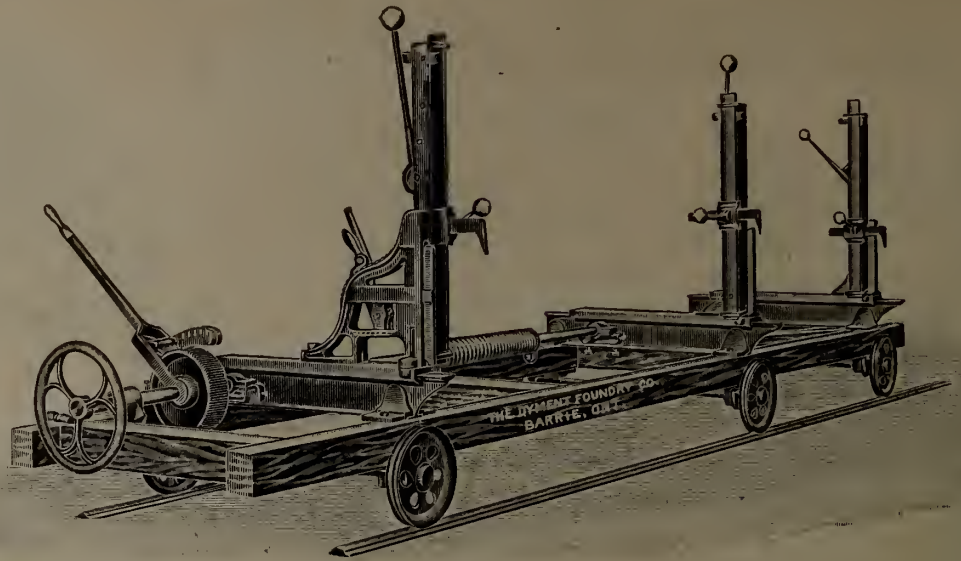

This is a light running Carriage and is quite suitable for small mills. Its capacity is about 15,000 feet per day. The wheels are 14 inches in diameter. The axles are $1\frac{3}{4}$ inches in diameter and go across frame. They are fitted with self-oiling boxes. The bunks are of steel. Blocks will recede 38 inches. An overset lever is supplied when desired, also spring receder and band brake wheel.

The feed on this frame is self-contained and can be used for either rope or rack and pinion. All the frictions have 7 inch face, two of them are made of paper, the other two of iron. The mandrel is made of steel and is 3 7-16 inches in diameter. The mandrel pulley is made in different sizes so as to suit the speed and width of drive belt. If desired this pulley may be put inside of frame.

WE MANUFACTURE AN IRON SAW FRAME

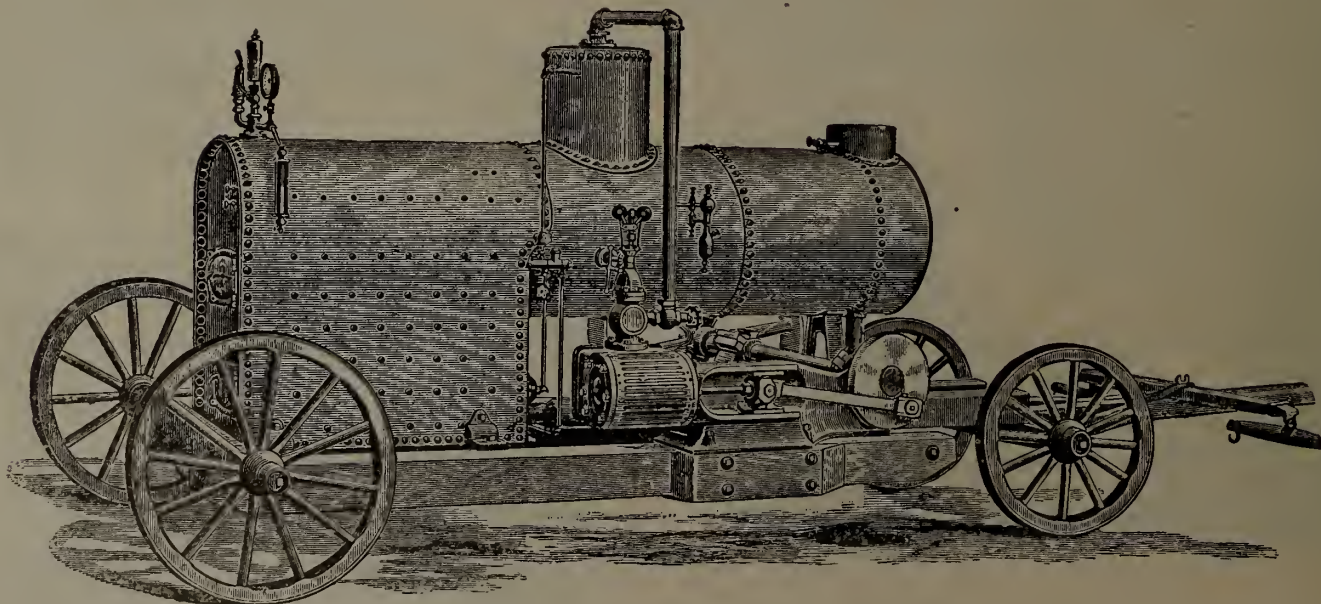
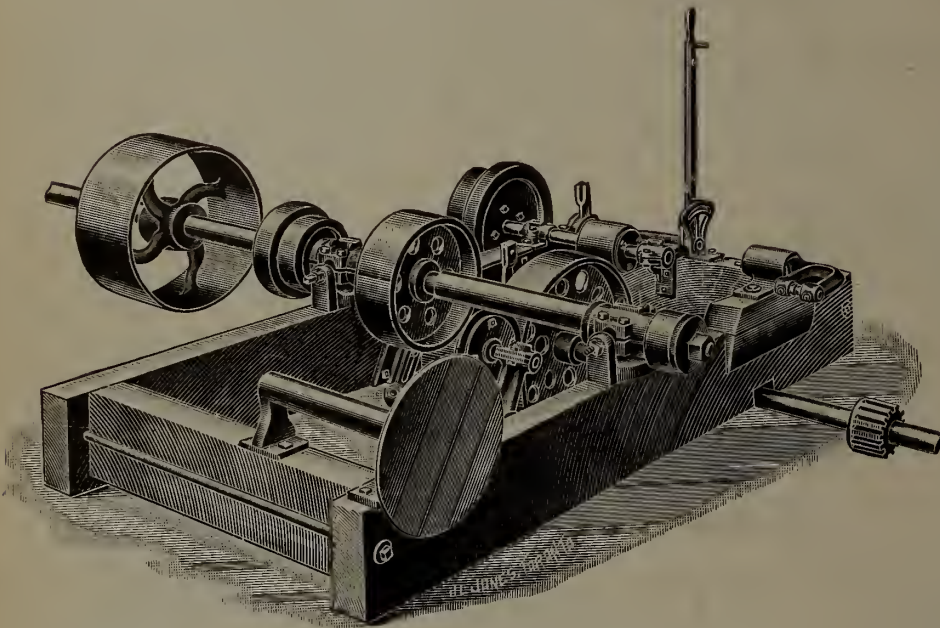

We manufacture these Engines and Boilers in two different sizes, 25 to 30 and 30 to 40 H. P.

This cut shows engine and boiler on wheels, but we will make them on skids if desired.

This outfit we consider the strongest and most serviceable on the market. We also supply this rig separately.

The Dymont Foundry Co., Barrie, Ont.

IT'S OUT

Our New XXXX Catalog is just out, showing and describing the most complete and comprehensive line of Hand and Power Feed Shingle, Heading and Box Board Machinery ever created. This book is

YOURS FOR THE ASKING

and should be in the hands of every manufacturer of Shingles, Heading or Box Boards in the country. A postal request brings it.

PERKINS & CO.
GRAND RAPIDS, MICH.

Gonnell & Dengler Machine Co.

ROCHESTER, N. Y.

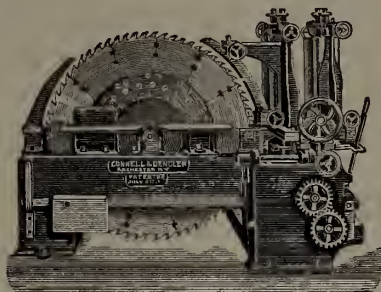

44 inch Circular Re-Saw.

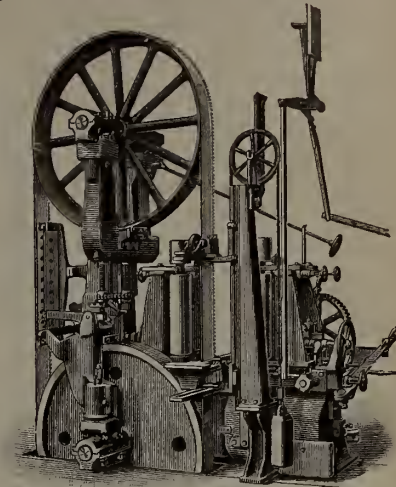

60 inch Band Re-Saw

Manufacturers of . . .

Box Makers' and Planing Mill Machinery



Heavy 26 inch Divided Roll Planer and Matcher with 8 Feed Rolls.

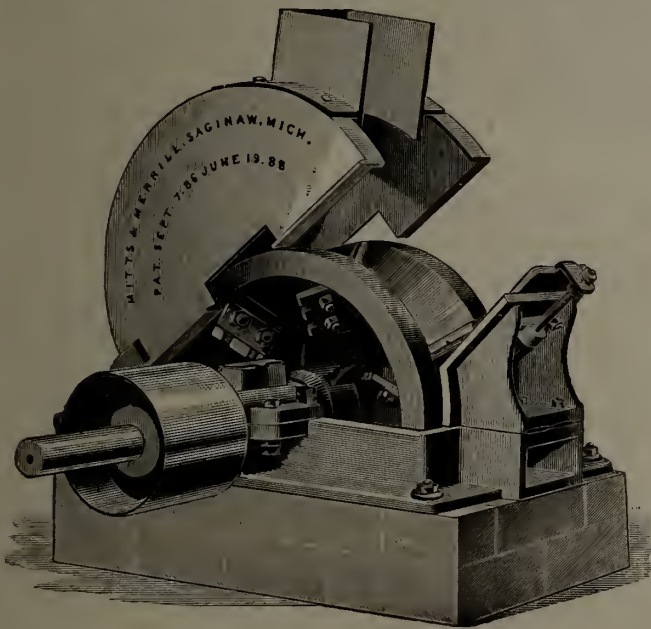

We Make **“HOG”** For Cutting

Slabs, Edgings and Blocks, Shingle, Sawdust and Splints, Planing Mill and Box Factory Refuse, Heading and Veneer Mill Waste, into fuel chips. Extract Chips into fine chips. Millions of dollars saved by their use. Try One. Write for circular “D”.

MITTS & MERRILL

807 Tilden Street, - - - Saginaw, Mich.

SEND FOR CIRCULAR E

“Maple Leaf” Stitched Cotton Duck Belting.

MADE IN CANADA.



MADE IN CANADA

“MAPLE LEAF” is made of the best cotton duck, woven to our own special formula.

“MAPLE LEAF” is the truest running belt on the market.

“MAPLE LEAF” is superior to either Rubber or Leather and in many places will do work that no other make of belt will.

“MAPLE LEAF” is suitable for all kinds of Factories, Mills, etc., for power and carrying.

Main Drive Belts a Specialty.

Ask for “MAPLE LEAF” and take no other.
BEWARE OF IMITATIONS.

USE OUR “MAPLE LEAF” BELT DRESSING.

Manufactured only by

DOMINION BELTING CO., LIMITED
HAMILTON, CANADA.

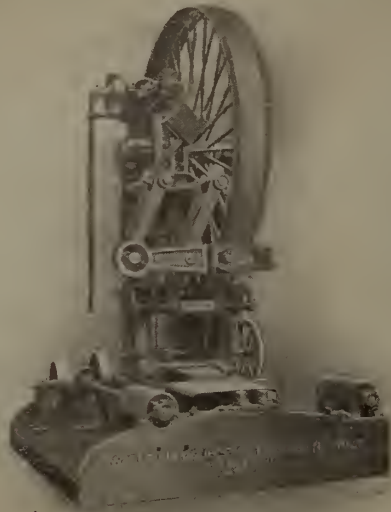

Double Cutting Band Mill.



Steam Setter and No. 1 Set Works.

Waterous Engine Works Company

Limited

Brantford

Canada

1844

1905



MANUFACTURERS OF COMPLETE LINES OF

**Saw Mill Machinery, Band Mills, Cast Steel Carriages,
 Steam Set Works, Steam Log Handling Machinery, Edgers,
 Trimmers, Slashers, Lath Machinery, Engines, Boilers, Etc.**

WRITE FOR CATALOGS



Four Block Cast Steel Carriage—Solid Oak Frame

NATURAL DRAFT **DRY KILNS**
MOIST AIR . . .

LUMBER TRUCKS and
TRANSFER CARS

Write for prices and particulars of the most simple and efficient Natural Draft Dryer on the market. Testimonials and list of users sent on application. Every square inch of heating surface is utilized to the uttermost and perfect ventilation and circulation is obtained by a very simple arrangement of ducts. Write for particulars to

SHELDON & SHELDON,
GALT, ONT.

FORMERLY McEACHREN HEATING & VENTILATING CO.

THE MENZ LUMBER CO.

British Columbia Fir, Spruce and
Red Cedar Lumber, British Col-
umbia Red Cedar Shingles, On-
tario White Pine. ❁ ❁ ❁ ❁ ❁

R. J. MENZ, President,
GEO. W. DULANY, Jr., Vice-
Pres. and Treas.
JOHN McDONNELL, Sec'y.

624-625 Union Bank Building
Winnipeg, Man.



McEACHREN HEATING & VENTILATING COMPANY, GALT, CANADA.

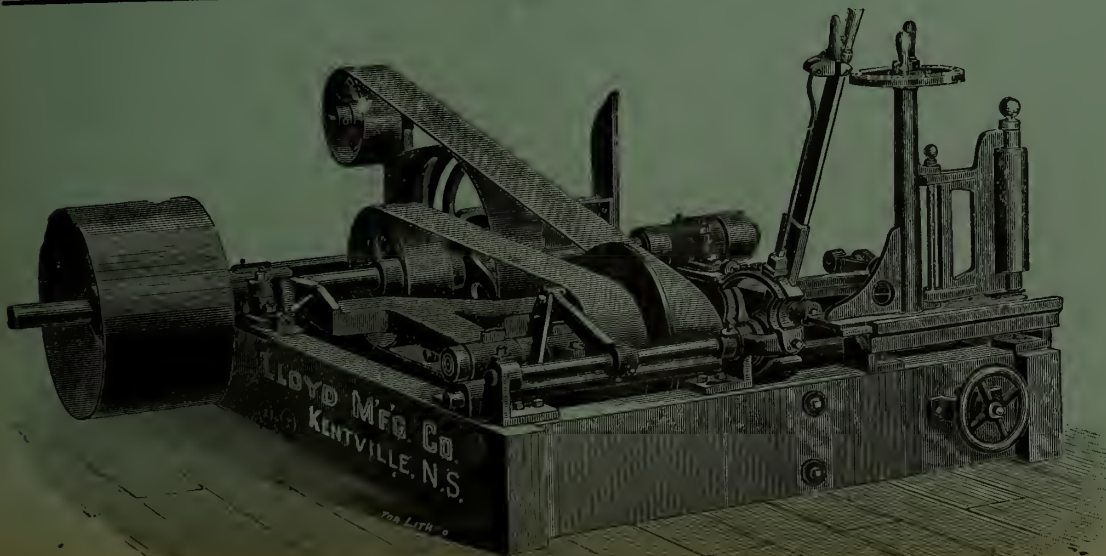

The Standard Dry Kiln Company
INCORPORATED IN INDIANAPOLIS, IND.

Your Truck Troubles

Will end when you abolish your troublesome, out-of-date trucks and treat yourself to a complete outfit of

The Standard
Channel Steel, Roller Bearing
Dry Kiln Trucks

the twentieth-century trucks. They never trouble. They are the lightest-running, most durable trucks ever made anywhere by anyone.

They have malleable iron wheels and spreaders, channel steel frame, "anti-friction" steel rollers with cone-shape ends, lathe-cut axles with milled ends, and other superior features that we'll be glad to tell you about.

Ask for Catalogue "D" and our booklet "Truck Truths."

THE STANDARD DRY KILN CO.
Indianapolis, Indiana, U. S. A.

FOR **DRY KILNS**

that will season lumber of all kinds and under all conditions, whether partially air-seasoned or green from the log, in shortest time and at least cost, entirely free from checking, warping or case hardening,

Write to—

Lloyd Manufacturing
Go'y JOHN I. LLOYD, Proprietor.

SAW MILL OUTFITS

Pulp Machinery, Belting, Etc.

OUR SPECIALTIES:

- Band Saw Mill Machinery,
- Improved Rotary Saw Mills,
- with Green Mountain Dogs,
- Also Screw Post Dogs,
- Turbine Water Wheels,
- Power Feed Gang Edgers
- Buzz and Surface Planers,
- Heading Rounders,
- Stave Machines, Stave Jointers,
- Stave Planers.

KENTVILLE, N. S.

USE "THE KING" We have 40 years' exper-

ience in the
MANIPULATION
of Metals.

ANTI



FRIC TION

BABBITT METAL

Bronze and Lead Castings a
Specialty for Pulp Mills.

THE JAMES ROBERTSON COMPANY, LIMITED

Montreal, Que. Toronto, Ont. St. John, N.B. Winnipeg, Man.

Steam, Power
and
Centrifugal Pumps,
Condensers,
Travelling Cranes.



Stock Carried in:

HALIFAX,
MONTREAL,
HAMILTON,
WINNIPEG,
VANCOUVER.

THE SMART-TURNER MACHINE CO., LIMITED
HAMILTON, ONTARIO

SEND FOR **H. W. PETRIE'S**
MONTHLY STOCK LIST
NEW & 2ND MACHINERY
TORONTO, CANADA

DO YOU USE
Number **128** Tacks

ACTUAL SIZE

We make them, also Steel Log
Hammers and Stamps, Brass
Stencils and Stencil Inks.

HAMILTON STAMP & STENCIL WORKS,
HAMILTON, ONT.

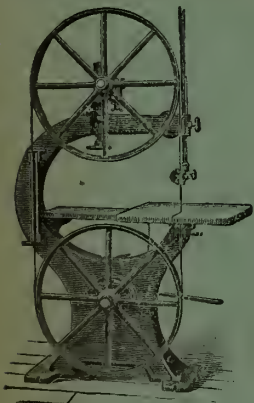

CRESCENT MACHINERY

Quality is all right.
So's the price.

Band Saws
Jointers
Saw Tables

Very low price on
BAND SAW BLADES

Catalogue tells the rest.

H. W. PETRIE

Dept. C. M.

TORONTO, ONT.



RIGE LEWIS & SON,
Limited
Lumbermen's Supplies

S
A
W
S

Chain
Bolts
Files

Steel
Iron
Horse Shoes

A
X
E
S

Peaveys
Pike Poles
Cant Hooks

Boot Calks
Lumber Leads
Timber Grips

R
O
P
E

TORONTO.

Write for Prices

THE LEATHER BELT THAT'S KNOWN OUR "EXTRA"

MONTREAL TORONTO WINNIPEG VANCOUVER

PINK LUMBERING TOOLS

The Standard Tools

In Every Province of the Dominion, * * * * *
* * * * * New Zealand, Australia, Etc.



Pink Round Bill Peavey, Handles in Split Maple

Pink Duck Bill Winter Cant Hook, Handles in Split Maple.

FINEST QUALITY SPLIT MAPLE CANT HOOK AND PEAVEY HANDLES

Boom Chains, Pike Poles, Skidding Tongs

Thomas Pink. Peavey. Exhibitor of Lumbermen's Tools, of his own manufacture.

THOMAS PINK

BRUNETTE SAW MILL COMPANY LIMITED

NEW WESTMINSTER, B. C.

P. O. Address, Sapperton

Manufacturers

FIR AND CEDAR TIMBER AND LUMBER AND CEDAR SHINGLES

SPECIAL ATTENTION TO HEAVY JOISTING AND
LARGE TIMBERS UP TO 100 FEET IN LENGTH

D. C. CAMERON, President and Manager.

WM. ROBERTSON, Secretary.

J. E. YOUNG, Cashier.

The Rat Portage Lumber Co., Ltd.

Manufacturers
of 33333

White and Red Pine Lumber, Lath, Shingles, Sash,
Doors, Turned and Band Saw Work

Dealers: CEDAR POSTS, POLES and TAMARAC PILING

Mills at RAT PORTAGE and RY RIVER, Ontario, WINNIPEG, Manitoba, and VANCOUVER, British Columbia. Head Office: RAT PORTAGE, Ontario

Our Vancouver Mill cuts High-Grade Cedar, Fir, Spruce and Red Cedar Shingles. Winnipeg Mills cut Pine, Tamarac and Spruce Lumber.
We also Manufacture all kinds of Mouldings, Sash, Doors, Turned Work and Boxes. Correspondence solicited at all four points.

THE LUMBER MUTUAL FIRE INSURANCE CO.

BOSTON, MASS.

NOVEMBER 1st, 1904

Total Losses Paid	-	-	-	-	-	\$ 203,353.11
Dividend Profits, Dividends Paid Policy Holders,	-	-	-	-	-	108,511.02
Undivided Profits, Net Cash Surplus,	-	-	-	-	-	116,099.04

PROGRESSIVE DIVIDENDS TO POLICY HOLDERS

1896	1897	1898	1899	1900	1901	1902	1903	1904
10%	10%	15%	20%	20%	20%	25%	30%	30%

You can participate in this SAVING from Stock Companies' Tariff Rates

MAIL - EXPIRING - POLICIES - WITH - ORDER



THE Northland of Ontario is rich ; rich not only in romance, but in the more tangible resources of timber, minerals and fertile land.

The white pine, which has vanished from most of its haunts south of the great lakes, musters its serried ranks over many hundred square miles of virgin forest ; and in the spruce, poplar and Banksian pine which line the southern and northern slopes of the Height of Land there is the potentiality of a world's supply of paper, mill-board and other articles made of pulp. There are besides large quantities of birch, maple, cedar, and other useful varieties of wood.

In minerals, the wealth of Ontario is equally great and varied. The famous nickel mines of Sudbury are the largest producers in the world, and the recent finds of silver, cobalt and arsenic on the line of the T. & N. O. Railway rank among the richest yet discovered. Iron ore is widely distributed, and the list of minerals is not exhausted by gold, copper, lead, zinc, mica, corundum and iron pyrites. Granite, sandstone, limestone, marl and brick clays are also abundant.

There are millions of acres of first-class clay land awaiting the settler in a good climate and covered with merchantable timber. Government railways now building will open much of these tracts.

For further particulars, maps, reports and land, timber and mining regulations, apply to

HON. A. G. MACKAY,

Commissioner of Crown Lands,

Toronto, Ont.

THE CANADA LUMBERMAN AND WOOD-WORKER

VOLUME XXV. }
NUMBER 2.

TORONTO, MONTREAL AND WINNIPEG, CANADA, FEBRUARY, 1905

TERMS, \$1.00 PER YEAR
Single Copies, 10 CENTS.

PAT. OSCILLATING BOB SLED KNEE

Handle 25 per cent. easier, and wears longer, and is lighter than all others.

THOMPSON MFG. CO., Ltd.,
Grand Bay, N. B.

JNO. S. FIELDING, C. E.

DAMS

Room 2, 18 Toronto Street - TORONTO

WIRE ROPE



All Kinds and Sizes and for All Purposes.

Standard and Lang's Patent Lay.

Prices Right. Prompt Shipments.

PROMPT SHIPMENTS

PRICES RIGHT Rope Fittings Rope Grease

THE B. GREENING WIRE COMPANY, LIMITED

HAMILTON, ONT.

MONTREAL, QUE

The Ottawa Saw Co. LIMITED
Middle Street, OTTAWA, ONT.
Sandvik Swedish Steel
Band, Gang and Circular Saws
P. M. FEENY, Manager.
OIL TEMPERED

Which is Wisest?

Some people buy belting on price, others on quality. Which is wisest?

J. L. GOODHUE & CO.,
DANVILLE, QUEBEC.

WOODS LIMITED

Wholesale Manufacturer of

LUMBERMEN'S SUPPLIES

Tents and Tarpaulins made of our special non-absorbent duck. Overalls, Top Shirts, Driving Pants, Shoes and Hats, Underwear, Blankets, Axes, Moccasins, etc.

64-66 QUEEN ST. - - OTTAWA, ONT.

DICK'S BELTINGS



Never is affected by wetness, and does not stretch

Excels in Transmission Power

Always Uniform.

LARGE STOCK ON HAND

WRITE TO SOLE AGENTS:

J. S. YOUNG, 413 St. Paul Street MONTREAL

D. K. McLaren

GENUINE

Oak Belting

MILL SUPPLIES

751 Craig St., Montreal.

132 Bay St., Toronto.



WIRE ROPE

IMMEDIATE DELIVERY
BEST QUALITY FROM STOCK WIRE ROPE FITTINGS
W. H. C. MUSSEN & CO.
MONTREAL, QUE.

WIRE ROPE

THE E. R. BURNS SAW CO.

TORONTO, ONT.

MANUFACTURERS OF HIGH-GRADE

Circular and Long Saws

UNEXCELLED

SHINGLE SAWS



The Wm. Hamilton Mfg. Co., Limited

Builders of a Complete Line of

SAW MILL MACHINERY



The

STEAM TENSION

BAND MILL FOR SINGLE OR
DOUBLE CUTTING

Before the introduction of the Steam Tension Mill, it had been the universal custom to maintain the strain on the saw by the use of some system of levers and weights.

It is well-known that the action of a weight--especially one as heavy as must be used in the tension mechanism of a band mill--is necessarily slow on account of its inertia.

Every practical mill man will admit that, in order to get the best results in sawing, the tension device should be very sensitive and capable of responding instantly to the varying demands of the work. As it is manifestly impossible for any form of weight tension to meet these requirements, we have

substituted for the weight a direct acting steam cylinder, so arranged that the strain on the saw can be varied at will from 3,500 pounds up to any required amount.

It will be evident to anyone familiar with the use of steam that the action of this saw straining device must be instantaneous, and consequently the saw will always be kept in proper tension to do its best work.

We have a booklet giving a great many more points of advantage possessed by this mill—write Dept. L for it.

Branch Office :
Vancouver, B. C.

Head Office and Works :

Peterborough, Ont.

R. H. SMITH CO., LIMITED

— St. Catharines, Ont. —

We are the Sole Manufacturers of Saws
under the

Simond's Process

in the Dominion of Canada.

There is no process its equal for tempering circular saws. Other makers recognize this fact, as some of them, in order to sell their goods, claim to have the same process. All such Claims are FALSE, as the patentee in the U. S. and ourselves are the only firms in the world who use it.



INSERTED TOOTH SAWS

Notice the improved shank. We call particular attention to the swell which strengthens it at the weakest part and which gives it more wear than the old style.

Shanks made in usual gauges and to fit your saws perfectly.

SHINGLE SAWS

The quality of the "Simonds" Shingle Saws is proven by the fact that the largest shingle and machine manufacturers in Canada are using them.

Run a "Simonds" and you will increase your output.



CROSS-CUT SAWS

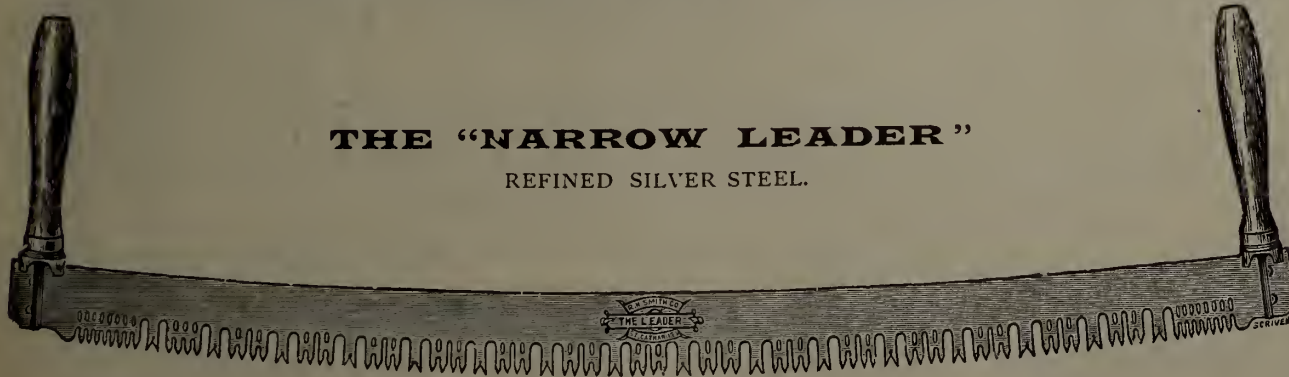

THE "NARROW LEADER"
REFINED SILVER STEEL.

The Simond's temper and style of tooth make the "Leader" the fastest and easiest cutting saw manufactured.

Write for prices.

R. H. SMITH CO., Limited, St. Catharines, Ont.

New 200 Page Green Book 1904 EDITION.

"Saw and Knife Fitting Machinery and Tools"

MAILED FREE ON REQUEST.

A Book for Mill and Factory Managers,
Superintendents, Foremen and Saw Filers.

BALDWIN, TUTHILL & BOLTON,
GRAND RAPIDS, MICH., U.S.A.



B. T. & B. Full Automatic Knife Grinder. Style D

SAW AND KNIFE FITTING

THE NEW B. T. & B. MANUAL

Revised edition. 144 pages. Copiously
illustrated and Durably Bound. Is an exhaustive
treatise on the care of Saws and Knives.

A Practical Book for Saw Filers.

Mailed Postpaid on Receipt of Price

\$2.00

THE "B. T. & B." LINE

NEED ANYTHING?

- Sharpeners, Swages,*
- Stretchers, Shapers,*
- Side Files, Shears,*
- Retoothers, Brazing*
- Machines, Filing*
- Clamps, Lap*
- Grinders, Lap Cutters,*
- Patch Machines,*
- Crack Drills,*
- Hammering Benches,*
- Bench Grinders,*
- Band Filers,*
- Band Setters,*
- Pulleys and Stands,*
- Brazing Forges,*
- Saw Sets, Saw Gauges,*
- Swage Bars, Upsets,*
- straight Edges,*
- Tension Gauges,*
- Back Gauges,*
- Leveling Blocks,*
- Anvils, Hammers,*
- Speed Indicator*
- Emery Dressers,*
- Knife Grinders,*
- Knife Balances,*
- Shingle Saw Grinders,*
- Burr Gummers,*
- Post Brackets,*
- Stretcher Bench*
- Brackets, Cutters,*
- Marking Stamps,*
- Saw Guides, etc.*

Andrews

Stands for

Three Comforts

Quality Efficiency Price



Kilns That Dry Your Lumber
Without Drying Up Your Bank Account

Write for Catalogue

The A. H. Andrews Co.

174-176 Wabash Avenue - - CHICAGO, U. S. A.

THE SCHAAKE MACHINE WORKS

NEW WESTMINSTER, B. C.

Builders of a Complete Equipment of

Saw^{and} Shingle Mill Machinery

SOLE MANUFACTURERS OF

Johnson's Improved Upright Shingle Machines

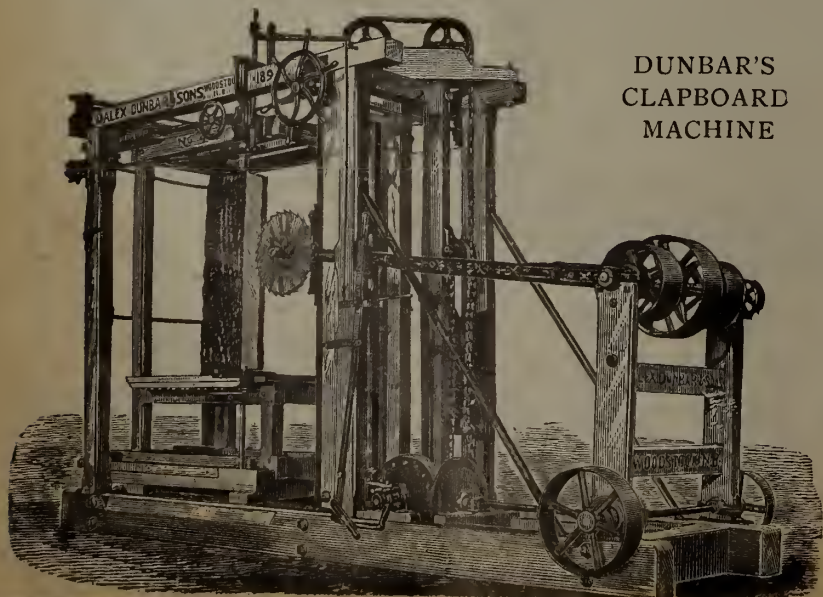

DUNBAR'S
CLAPBOARD
MACHINE

ALEX. DUNBAR & SONS

Woodstock, N. B.

Manufacturers of



Saw Mill Machinery

OF ALL KINDS

Including ROTARY SAW MILLS (3 sizes), CLAPBOARD SAWING
MACHINES, CLAPBOARD PLANING AND FINISHING MACHIN-
ERY, SHINGLE MACHINES, STEAM ENGINES, Etc.

WRITE FOR FURTHER PARTICULARS

ALEX. DUNBAR & SONS - Woodstock, N. B.

JOSHUA OLDHAM & SONS

ESTABLISHED 1870.

NEW YORK SAW WORKS

The Oldham Saws for Sawmills

BRIDGE OVER THE CARES, AND LEAVE



PLEASANT REFLECTIONS OF
SUCCESSFUL LUMBER PRODUCTION

JOSHUA OLDHAM & SONS

NEW YORK SAW WORKS

BROOKLYN BOROUGH
NEW YORK

The DODGE Split Friction Clutch Pulley

Perfect Balance
Easy to Adjust
Liberal Clearance
Excellent Lubrication
Repairs Easily Made

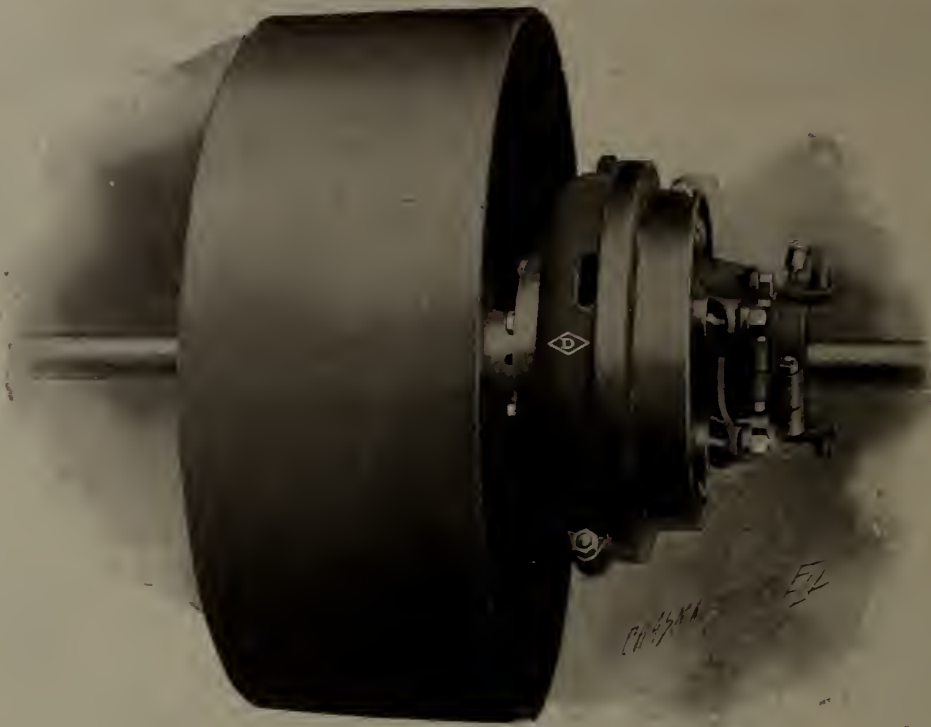

Simplicity
Positive Friction
The Split Feature
Low First Cost
Detachable Sleeve

In use in many of the representative Saw and Planing Mills from coast to coast.
Write us about Friction Clutch Pulleys and Couplings.

SOLE MAKERS :

DODGE MANUFACTURING CO.

TORONTO - MONTREAL

THE TRIUMPH TURBINE



Is the most powerful wheel on the market to-day. A glance at this cut of the centre shows that the buckets are designed to secure the **maximum of speed** with **great power** and a **free discharge**. Mr. E. S. Edmondson, of Oshawa, writes as follows under date of November 16th, 1903, regarding a 26 inch Vertical Triumph Wheel :

"The Wheel is strictly first-class in every particular, and after a careful and thorough test I am prepared to say that I believe it is the best wheel in the market for Electrical purposes. It has high speed, large power, high efficiency at part gate, and has practically no leakage. I am more than pleased with the thorough and workmanlike setting you gave me throughout."

For horizontal settings in large Pulp Mills, Cement Mills or Electric Power Developments this Wheel has no equal. We invite your enquiries. Large catalogue to be had for the asking.

We are always glad to submit estimates and prices on **Improved Vulcan and Leffel Turbines, Improved Lane Circular Saw Mills, Edgers, Trimmers, Slashers, Shingle Machines, Lath Machines** and all machinery of this kind.

MADISON WILLIAMS

H. E. PLANT, Agent
Cor. Common and Nazareth Streets
Montreal, Que.

Successor to Paxton, Tate & Company
PORT PERRY, ONT.

Manitoba Iron Works
Western Selling Agents
Winnipeg, Man.

Moreau's Pulpwood Barking Machine

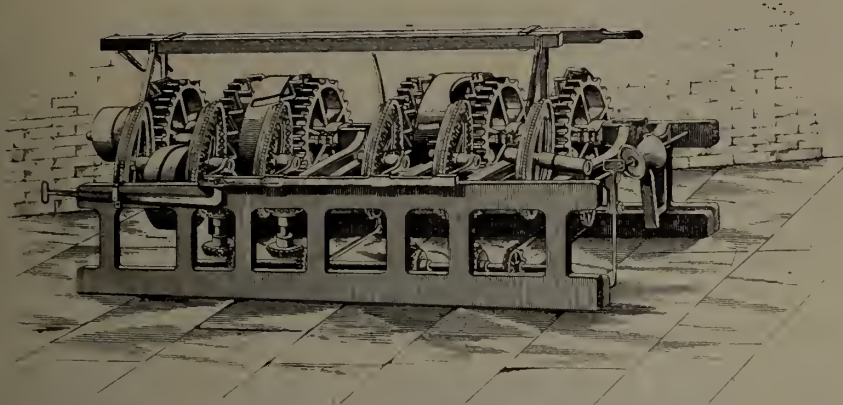

WEIGHT 4,200 LBS.

Latest and best Pulpwood Barking Machine. Requires about 7 h. p. to drive it full speed in work and one man can handle it and bark 22 to 30 cords of 4 foot wood per day according to average size of wood.

Wood is fed end on and any size from 3 to 24 inches, as the wood runs without loss of time between sticks. No long shavings and greatest economy in wood. Machines may be seen working any time. Write me for particulars.

R. S. P. SMYTH - QUEBEC, QUE.

Sole Agent for Canada

*P. O. Box 236
L. D. Phone 386*

THE E. LONG MANUFACTURING CO., ORILLIA, ONT.

THESE SAW CARRIAGES ARE MADE OF CAST STEEL, AND OPEN 36 TO 54 IN. FROM SAW.

We build Double Edgers, Steam Feeds, Log Jacks, Live Rolls, Trimmers, Slab Slashers, Steam Niggers.

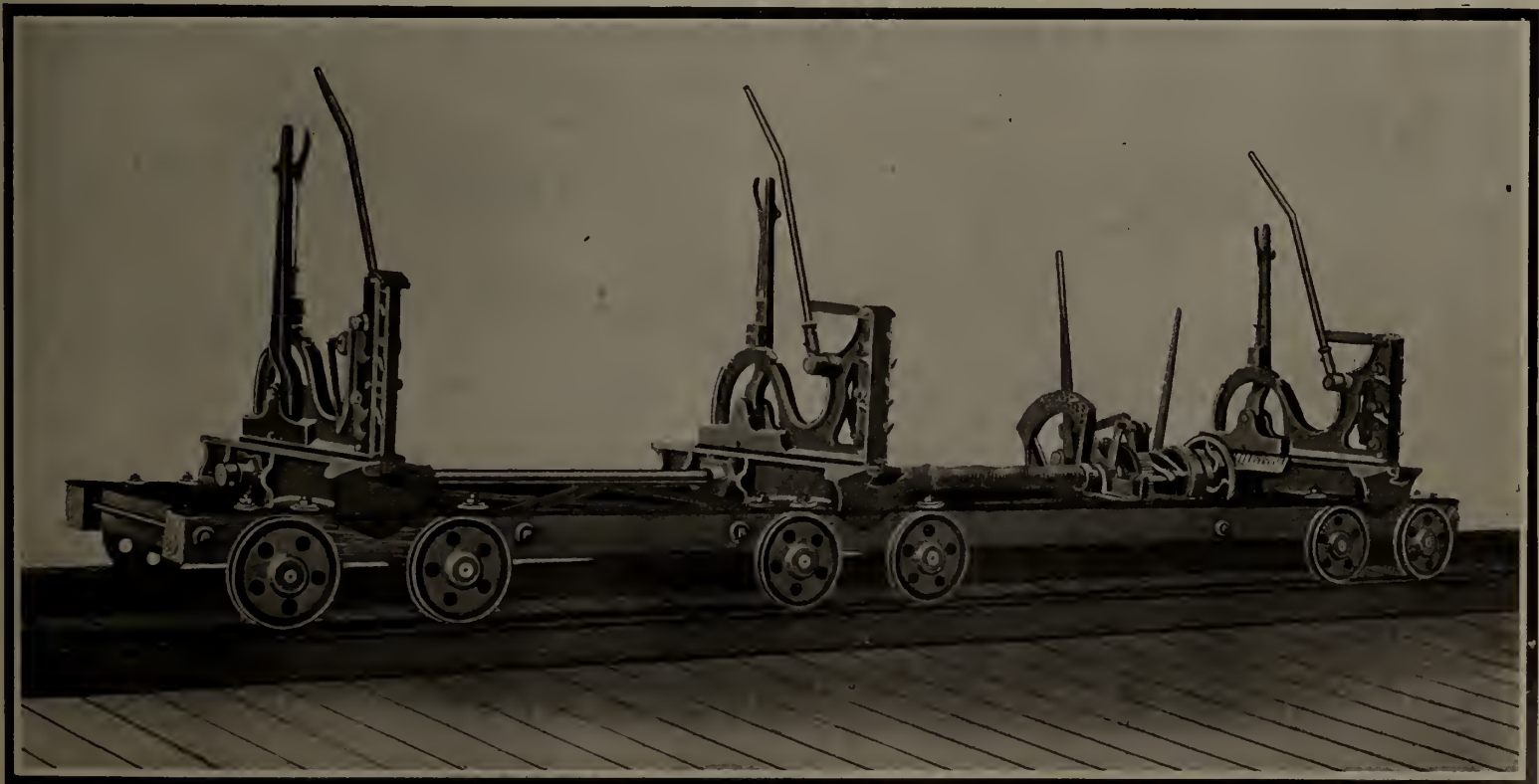

COMPLETE LINE OF SAW AND SHINGLE MILL MACHINERY
WRITE FOR CATALOGUE AND PRICES

BRITISH COUMBIA LUMBER AND SHINGLE MANUFACTURERS

The Canadian Pacific Lumber Co., Limited
PORT MOODY, B. C.

Manufacturers and Wholesale
Dealers in All Kinds of

B. C. LUMBER, LATH, MOULDINGS, ETC.

The Largest Shed and Dry Kiln Capacity of any Mill in British Columbia.
Special Attention Given to Orders from Manitoba and the Territories.



Long Distance
Telephone Connection.



Address the Company at Port Moody or
BYRNES & CUDDY, Selling Agents, WINNIPEG

CLOVERDALE MILLING CO., CLOVERDALE, B. C.

== Red Cedar Shingles ==

OUR SPECIALTY

SECOND TO NONE

CORRESPONDENCE SOLICITED

PETER LUND, Managing Director.

J. BRECKENRIDGE, President.

MANUFACTURERS OF
ALL KINDS OF

Crows Nest Pass
Lumber Co., Limited
WARDNER, B. C.



BUILDING MATERIAL

Capacity 150,000 Feet Per Day.

THE KING LUMBER MILLS, LIMITED, CRANBROOK, B. C.

Manufacturers
of

Building Materials

And All Kinds of DIMENSIONS, FLOORING, CEILING and BASE and CASE MOULDINGS

Columbia River Lumber Company, Limited

HEAD OFFICE AT GOLDEN, B. C.

Largest Capacity in Mountains

MANUFACTURERS OF ALL KINDS OF

MILLS AT { GOLDEN, B. C.
BEAVER, B. C.
KAULT, B. C.
CARLIN, B. C.

ROUGH AND
DRESSED

LUMBER

FIR, SPRUCE
CEDAR AND PINE

LATH

Telephone Poles,
Piling, Etc., a
Specialty.

The Fernie Lumber Co., Limited, Fernie, B. C.

MANUFACTURERS OF AND DEALERS IN ALL KINDS OF

ROUGH AND DRESSED LUMBER

Dimension and Bridge Timber a Specialty.

Moulding in Stock or Made to Order.

H. CAMERON, Manager.

DONALD GRANT, President.

Moyie Lumber & Milling Co., Limited, Moyie, B. C.

Manufacturers and Dealers in All Kinds of

FLOORING, CEILING, SIDING SHIP LAP COMMON BOARDS, DIMENSIONS AND LATH

Specialty: MOUNTAIN TAMARAC

JOS. GENELLE, Manager.

J. G. BILLINGS, Secretary.

THE YALE-COLUMBIA LUMBER COMPANY, LIMITED

Head Office: NAKUSP, B. C.

Mills at Nakusp, Westley and Cascade, B. C.

MANUFACTURERS OF

DEALERS IN

All Kinds Rough and Dressed Lumber,
Mouldings, Lath, Etc.

Cedar and Fir Piles, Telephone and
Telegraph Poles, Fence Posts, Etc.

BRITISH COLUMBIA LUMBER AND SHINGLE MANUFACTURERS

Canadian Timber & Saw Mills, Limited, Trout Lake, B. C.

MANUFACTURERS OF ALL KINDS OF

ROUGH AND DRESSED LUMBER

Specialties: Clear Cedar and High Grade Cedar Shingles

Send on Your Orders to the Above Company.

Prompt Shipments Guaranteed.

Capacity: 60,000 feet per day; 80,000 Shingles.

J. A. SAYWARD

MANUFACTURER OF AND DEALER IN

Cedar and Spruce Lumber

Shingles, Lath, Spars, Etc.

ORDERS CAREFULLY EXECUTED
PROMPT SHIPMENTS

VICTORIA, B. C.

THE BRITISH COLUMBIA MILLS, TIMBER & TRADING COMPANY

Head Office: VANCOUVER, B. C.

Winnipeg Office: Merchants Bank Building P. O. Box 235

MANUFACTURERS OF

BRITISH COLUMBIA FIR, CEDAR and SPRUCE—both Rough and Dressed. Sash, Doors, Mouldings, Lath and the Highest Grades

“ROYAL CITY BRAND”

RED CEDAR SHINGLES

DOUGLAS FIR TIMBER

All Widths and Thicknesses up to 120 feet in Length Supplied on the Shortest Possible Notice.

OWNERS AND OPERATORS OF

HASTINGS SAW MILL - VANCOUVER, B. C.
ROYAL CITY SAW MILL, VANCOUVER, B. C.

ROYAL CITY SAW MILL, NEW WESTMINSTER, B. C.
MOODYVILLE SAW MILL - BURRARD INLET, B. C.

Total Capacity, 400,000 Feet of Sawn Lumber per Working Day of Ten Hours.

The Ladysmith Lumber Co., Limited

LADYSMITH, B. C.

Manufacturers of

LUMBER, LATH, SHINGLES,
MOULDINGS, ETC.

SPECIALTY: The best Cedar Shingles manufactured on the Coast.

FRESH WATER FIR LATH ALWAYS IN STOCK.

Capacity of Shingle Mill, 100,000 per day of 10 hours.

Correspondence Solicited

GREAT NORTHERN LUMBER CO., LIMITED

Our Specialty

Pacific Coast Red Cedar Lumber

Expertly Manufactured and Culled.

Correspondence Solicited.

ADDRESS:

R. D. RONSON, General Manager.

Vancouver, B. C., Room 19, Inns of Court

Scribner's Lumber and Log Book

A handy book for Lumbermen. Gives Correct Measurements of Scantlings, Boards and Planks; Cubical Contents of Square and Round Timber; Doyle's Rules, and much other practical information.

ADDRESS

THE CANADA LUMBERMAN, Toronto, Ont.

Price 35 Cents

BRITISH COLUMBIA LUMBER AND SHINGLE MANUFACTURERS

North Star Lumber Co., Limited, Cranbrook, B. C.

Manufacturers of

PINE, FIR and TAMARAC LUMBER

Specialty: Heavy Timber and Piling

D. & J. HADDEN, CLOVERDALE, B.C.

MANUFACTURERS AND DEALERS IN THE HIGHEST GRADE

LUMBER AND RED CEDAR SHINGLES

Send your orders to the above firm, who can supply you with shingles that cannot be beaten for quality and prices.

Agent for Ontario: Woodstock Lumber and Manufacturing Co., Woodstock, Ont.

BIG BEND LUMBER CO., LIMITED, ARROWHEAD, B. C.

Manufacturers of

Lumber, Lath and Shingles

CORRESPONDENCE SOLICITED



THE PIGEON RIVER LUMBER COMPANY PORT ARTHUR, ONT

MANUFACTURERS OF

Band Sawed White Pine Lumber, Lath, Pine and Cedar Shngles.

are operating their extensive plant night and day, to keep abreast with orders.

THERE IS A BECAUSE— A trial order will tell you why.

Winnipeg Representative, D. J. McDONALD, Clarendon Hotel.

Robinson McKenzie Lumber Co., Limited

Cranbrook, B.C.



... MANUFACTURERS ... OF ALL KINDS OF ...

Rough and Dressed Lumber, Mouldings, Casings, and Lath

P. O. DRAWER H

Mouldings

Shingles

VICTORIA LUMBER AND MANUFACTURING CO., LIMITED

MILLS AT CHEMAINUS, B. C.

FIR AND CEDAR LUMBER

of all descriptions, in straight or mixed cars.

We can supply large and long timbers, but don't care to ship anything over 40x40x140 feet long.

Prompt Shipments Good Quality and Manufacture Long Lived Timber

ADDRESS—

CHEMAINUS, B. C.

D. B. GRANT.

T. W. KERR

DELTA SAW MILL CO.

MANUFACTURERS OF

Rough & Dressed Lumber, Lath, Shingles Fence Pickets, Doors, Sash, Mouldings, Salmon and Fruit Boxes, and Round Tanks

Correspondence Solicited. LADNER, B. C.

Please mention this paper when corresponding with advertisers

Galt Machine Knife Works

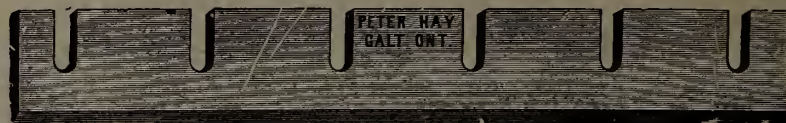

MACHINE KNIVES OF EVERY DESCRIPTION FOR Woodworking Machines

... Send for Price List... The Peter Hay Knife Co., Limited - Galt, Ont.

Modern High-Grade
Wood-Working Machinery

For Manufacturing
**HUBS, SPOKES, WHEELS, WAGONS,
CARRIAGES, RIMS, SHAFTS, POLES,
NECK-YOKES, SINGLE TREES, BARREL
HOOPS.**

Handles of Every Kind, insulated Pins, Spools,
Bobbins, Oval Wood Dishes, and General Wood-
Work.

Invented and Built by

THE DEFIANCE MACHINE WORKS,
Defiance, Ohio, U. S. A.

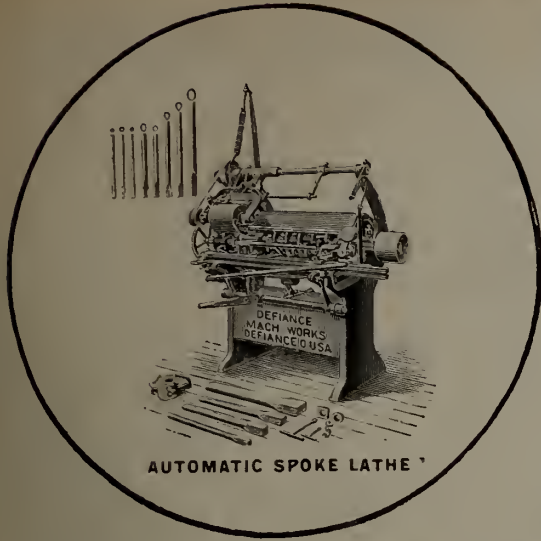

AUTOMATIC SPOKE LATHE

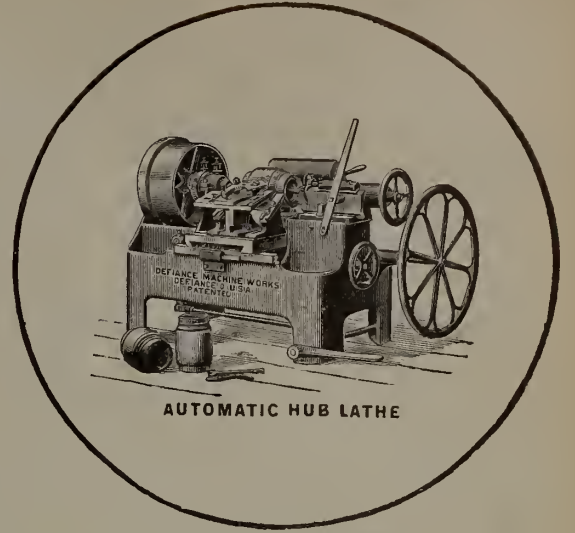

AUTOMATIC HUB LATHE

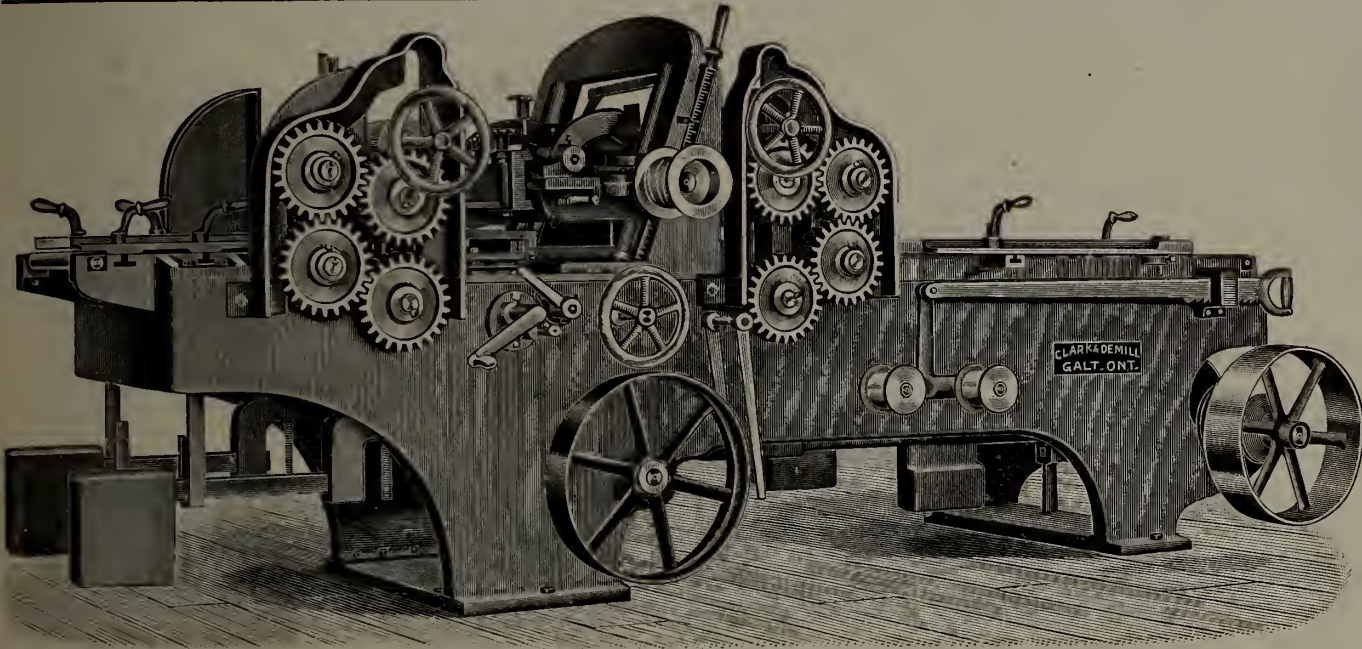

**Our No. 72
LIGHTNING PLANER
AND MATCHER**

Kindly note that we make this machine in different sizes, single or double cylinder, as desired. Parties desiring thoroughly up-to-date machinery will find it to their advantage to write us before placing their order.

Write for new Catalogue.

**Clark & Demill
Galt, Ont.**

Our Celebrated

Rotary Cutting Veneer Machines

made in over sixty sizes, have stood the test and proved equal to any proposition to reduce logs into thin lumber and veneers.



The product is high grade.
The output is great.
The cost of operating and maintenance is reduced to a minimum.
Quite a combination, is it not?

Timber and mill owners should get in early.
Buy a Coe Veneer Cutting and Drying outfit and prepare to supply thin lumber and veneers which have a healthy growing demand. More money in it than sawing your logs into lumber.

WRITE US.

THE COE MANUFACTURING COMPANY, Painesville, Ohio, U. S. A.

Established 1852.

Largest Builders of Veneer Cutting Machinery in the world.

TEON BELTING



STEAM PROOF
WATER "
HEAT "
OIL "
ACID "

Stronger and Cheaper than
Leather.

LEATHER BELTING

CAPATA BELTING [BALATA TYPE]

CAMELS HAIR BELTING

LACE LEATHER, ETC.

Special Arrangements for Trial Belts.
Write for Price Lists and Discounts.

P. H. WILBY, 27 1/2 Front Street East, TORONTO

Phone Main 1930.

SOLE AGENT FOR CANADA.

Dundas Lumberman



A New Axe tempered by a new process which enables us to submit to any lumberman three or more samples of Axes, all different degrees of hardness, and on a selection being made we will guarantee to furnish any number all exactly the same temper as sample chosen.

THE DUNDAS AXE WORKS

Dundas, Ont.

LARGE STOCK CARRIED & CUT TO ANY LENGTH
BLOCKS, CLIPS, TURNBUCKLES, ETC.

WIRE ROPE

SPECIAL ROPES FOR LUMBERING

DOMINION WIRE ROPE Co., LTD
MONTREAL, QUE.

EVERY LUMBERMAN WANTS IT—

35 cents buys it

Scribner's Lumber and Log Book

BRIMFUL OF EVERY-DAY
PRACTICAL INFORMATION

Address :
THE CANADA LUMBERMAN, Toronto

STEAM BOILERS



Portable Boilers—Locomotive Style
Return Tube Tubular

Tanks, Water Towers, Smoke Stack, etc.

CANADA FOUNDRY COMPANY, LIMITED

Head Office and Works: TORONTO, ONT.

District Offices: Montreal Halifax Ottawa Winnipeg Vancouver Rossland Calgary

ENGINEERS

FOUNDERS

MACHINISTS

BUHL MALLEABLE
COMPANY,
DETROIT, MICH.

Elevating, Conveying and Power
Transmitting Machinery

SPROCKET CHAIN AND WHEELS

MALLEABLE OR STEEL BUCKETS

We Guarantee our Goods to be of Standard
Design and Unexcelled Quality.

Belt Conveyors and Spiral Steel Conveyors

The Fairbanks Company

MONTREAL TORONTO VANCOUVER WINNIPEG



Garlock Packing Co.

HAMILTON - - - CANADA

—SOLE MANUFACTURERS OF—



GARLOCK'S PACKINGS

PATENTED

Asbestos and Mineral Wool Pipe and Boiler
Coverings, Engineers' Supplies in General



THE CANADA LUMBERMAN AND WOOD-WORKER

VOLUME XXV.
NUMBER 2.

TORONTO, MONTREAL, WINNIPEG, FEBRUARY, 1905

TERMS, \$1.00 PER YEAR
Single Copies, 10 Cents

INVENTOR OF "READY-MADE" HOUSES.

Ideas and executive ability are qualities which will bring any man to the top among the many who are engaged in his particular calling. Generally the two are associated with capacity for work, and the man with these possessions almost invariably has the common-sense to thoroughly learn every detail of his business so that he may understand any point which may arise at any time. With a well-grounded knowledge he can deal intelligently with questions when they come up, and is all the more able to devise some way out of the difficulties which at all times present themselves. Such a man is not only of use to the company with which he may be employed, but he is also of benefit to the industry with which he is connected. He is not long at the bottom, as individual worth is soon recognized and he is given an opportunity to climb the ladder of success.

When Mr. Edwin C. Mahony first engaged with the British Columbia Mills, Timber and Trading Company, the largest lumber manufacturers in British Columbia and one of the most extensive establishments of its kind on the Pacific Coast, he took a situation at the New Westminster branch of the company as laborer. Not that he had had no experience in the lumber business, for prior to his coming to British Columbia he had been engaged, from 1886 to 1889, with the firm of Flatt & Bradley, who were then operating a general saw mill business at Casselman, Ontario, near the city of Ottawa, as well as in the State of Michigan, and were also largely interested in the square timber export trade. He learned considerable about the industry as it is conducted in the east, but when he came west in April of 1890 he discovered that different methods obtained. Timber was larger, conditions were different, and there being little or no market or use for anything except the regular stock sizes of lumber, all the by-product was consigned to the mill waste fire. It was not long before Mr. Mahony was made tallyman, and the yard foremanship followed. He had ideas of his own in regard to the piling of dimension stuff in the yard, and adopted a system of alleys between each width and the piling of various lengths separately. This permits the loading of trucks and delivery wagons without extra handling, such an arrangement being of great convenience, especially when the stock lengths run from 10 to 32 feet as they do here. This work brought him to the notice of the officials of the company and in less than a year and a half he was transferred to the head offices at the Hastings mill branch in Vancouver, where he was given charge of the inauguration of the local

and car trade. At that time Vancouver was just beginning to assume size, and previously the local trade had not been catered to at this mill, it having engaged only in the export shipment. Since then the B.C. Mills, Timber and Trading Company's local business and car trade to the east has so developed that it is by far the largest in the province.

On November 1st, 1901, he was promoted to the management of the Royal City Mills, Vancouver, one of the branch establishments of the company, and it is from this office that the local trade is conducted. From being one



MR. E. C. MAHONY, Vancouver, B. C.

of the biggest risks of insurance companies, this mill and yard now holds the record of having the best rating of any plant of its kind in British Columbia, another indication of the ability of the man in charge.

It was about this time that Mr. Mahony first took into consideration the utilization of the by-product of the mill, which has eventually developed into the construction of "ready-made" houses, specimens of which elicited such favorable comment when displayed this year at the exhibitions at Winnipeg and New Westminster. The manufacture of these is now about to form one of the features of the business of the B. C. Mills, Timber and Trading Company. The construction of these houses was not thought out in a day. Starting with the idea of making some use of the large amount of odd stock, development gradually progressed, until after a very considerable amount of experimenting it has been brought to a success which is beyond the original expectations of the inventor and the company.

The handsome catalogue about to be issued shows what the evolution of Mr. Mahony's idea has amounted to, and which is a surprise to builders. Many of the houses have been erected in Vancouver and vicinity, and the numerous orders constantly being received from provincial, Canadian and foreign points indicate that they are meeting a universal want, and are giving entire satisfaction.

The subject of this article was born in Hamilton, Ontario, on December 14th, 1864, his parents being Mr. and Mrs. John C. Mahony. He is descended from good old United Empire Loyalist stock, and on his mother's side is connected with the Gage family, well known throughout the Niagara peninsula. After attending the public and high schools of Hamilton, young Mahony took a course at the Ontario Agricultural College, graduating in 1882. Until 1886 he farmed on the Peter Gage homestead, four miles east of Hamilton and within two miles of the battlefield of Stoney Creek, famous in Canadian history. After that he took his first lessons in the lumber industry.

Mr. Mahony was married to Miss Clara, only daughter of Mr. Nathaniel Hill, of Smithville, near Grimbsy, and has two daughters. He is a staunch Mason, being member of the Blue, Royal Arch and the Commandery.

NEW WOODENWARE FACTORY.

The incorporation of the Keenan Woodenware Manufacturing Company, Limited, has been announced. The promoters of this company are the Keenan Brothers, of Owen Sound, who represent the entire capital of \$100,000. Some time ago the well-known lumber firm of Keenan Bros. purchased the business of the Parkhill Basket Company at Owen Sound, and the incorporation of a new company means the extension of this business to include the manufacture of many descriptions of woodenware. With that end in view, new buildings are being erected, the first of these being a stave mill 30x30 feet and two storeys high. Connected with this by an elevated tramway is a tower dry kiln 16x60 feet and 20 feet high, with 16 compartments which can be operated separately and in which the staves from the mill can be dumped from the trucks with the minimum of handling. The engine and blowers will be installed in a separate brick engine room, which will also contain an electric lighting plant. To the north of these buildings another kiln has been erected, of the horizontal type, 50x60 feet, and divided into three compartments lengthwise—one each for basket stock, pail and tub bottoms and lumber.

ANNUAL LUMBER TRADE REVIEW

Statistics of the Production and Export in 1904.—Conditions Unfavorable to Expansion and Prices Generally Lower Than in the Previous Year.—Decline in European Shipments.

GENERAL SURVEY.

Uncertainty characterized the lumber trade of Canada during the year 1904. Confidence was lacking and on all sides there was a strong inclination towards conservatism. The record is therefore unfavorable in comparison with the previous year. The two most important influences were the commercial depression in Great Britain, which was more severe in lumber than in many other commodities, and the Presidential election in the United States.

Lumber prices in the British market declined steadily during the first six months of the year, and shippers who had contracted for stock at the higher prices ruling in the winter of 1903-04 were face to face with very small profits and in some instances actual loss. The result was an early decision to restrict shipments as far as possible, which action was responsible for a partial recovery in the British market towards the close of the year. The import by the United Kingdom from all countries was 9,306,278 loads, as compared with 10,108,564 loads in 1903. The London import was exceptionally light, being more than 8,000,000 pieces less than in the previous year.

The Presidential election ceased to be a market influence early in the Fall, when the return of the Republican party to power was almost unanimously conceded. But during the summer months the lumber demand in the United States reached a low point, and the manufacturers, in order to preserve their home market, exported largely to Canada. This competition was felt keenly in the West, as in many instances the imported lumber was sold below the cost of production. The exports from the State of Washington are an indication of the extent to which American lumber was shipped into this country. The shipments of lumber via the Canadian Pacific Railway were 1,962 cars of lumber, as compared with 632 cars in 1903 and 823 cars in 1902. Calculating on 10,000 feet to the car, the Canadian Pacific Railway brought into Canada last year from Washington alone 19,620,000 feet of lumber.

The export trade of the year shows a considerable decline, the shipments from Montreal and other St. Lawrence ports being 142,000,000 feet less than in 1903. New Brunswick is responsible for a falling off of 30,000,000 feet, and British Columbia for approximately 20,000,000 feet. The most severe decline was probably in New Brunswick spruce, which sold in the late summer \$4 per thousand less than at the beginning of the year. There were some recessions in the higher grades of white pine, but the lower qualities remained comparatively firm throughout the year. The lumber industry of British Columbia suffered as a result of over-production, as well as on account of inadequate protection against American competition.

ONTARIO.

Considering the adverse influences tending to unsettle the lumber market, the manufacturers in Ontario have reason to feel satisfied with the business of the year. There was a large home consumption and an average trade with the United States. Possibly more than one-half of the Georgian Bay pine production was marketed in the United States, while the Ottawa Valley mills continued to send some lumber across the line. As compared with 1903, the shipments from the Ottawa Valley to the United States show a falling off in value of upwards of \$300,000.

The British demand was the weak feature of the year's operations and was responsible for a rather sharp decline in the price of the upper grades of pine. Inch No. 1 cuts and better were held at \$42 at the mill at the beginning of the year, but by midsummer had declined to \$38. All cutting up stock was depressed at a range of from \$2 to \$4 lower than in 1903. The common grades were in relatively better demand and firmer, while mill culls and other coarse grades sold about \$1 per thousand higher than in the previous year. The average price of mill culls was \$11.50 f.o.b. cars at point of manufacture. Box lumber was in good request, although the demand was less urgent than in 1903.

The year was favorable for manufacturers of hemlock, which was used largely for building purposes and construction works where white pine was too expensive. The tendency of prices was upwards, the average mill quotation being from \$11 to \$11.50, a gain of about \$1.

Hardwoods were comparatively steady and only slightly influenced by the weakness in pine, this being due no doubt to the steadily increasing domestic demand. Basswood alone showed decided weakness, this in contradistinction to the course of that lumber in the previous year. The price had evidently been boosted to a point which encouraged the use of substitutes for many purposes, and a decreased demand and lowering of values was the result. Birch also suffered early in the year, but recovered later. Prices of maple were slightly higher.

Mr. H. M. Sanford, U.S. Consul at Ottawa, furnishes the following statement showing the value of lumber shipped from the consular district of Ottawa to the United States in the past two years :

VALUE OF LUMBER SHIPPED FROM CONSULAR DISTRICT OF OTTAWA TO THE UNITED STATES.

	1903.	1904
White Pine.....	\$1,558,537.45	\$1,176,616.63
Red Pine.....	26,117.79	2,452.03
Spruce.....	77,017.36	108,248.44
Basswood.....	22,098.84	13,648.20
Ash.....	7,497.12	10,133.10
Hemlock.....	2,131.22	8,217.59
Birch.....	941.13	796.00
Elm.....	345.77
Maple.....	90.00
Total.....	\$1,694,776.68	\$1,320,111.99

Turning now to production, we find that the cut of the Georgian Bay mills was lighter than in 1903. Our figures show a reduction of 45,000,000 feet, but it should be explained that the actual decrease was somewhat greater, as two or three mills from which reports were not received in 1903 are included in this year's estimate. The comparison is as follows :

GEORGIAN BAY LUMBER PRODUCTION.

	1903.	1904.
Midland.....	64,000,000	60,000,000
Parry Sound.....	57,000,000	50,000,000
Byng Inlet.....	42,000,000	52,000,000
Sarnia.....	36,000,000	45,000,000
Little Current.....	46,000,000	37,000,000
Victoria Harbor.....	50,000,000	46,000,000
Waubashene.....	30,000,000	32,000,000
Blind River.....	51,000,000	43,000,000
Spragge.....	27,000,000	27,000,000
Sandwich.....	26,000,000	21,000,000
Gravenhurst.....	25,000,000	25,000,000
Cutler.....	37,000,000	28,000,000
Penetanguishene.....	40,000,000	17,000,000
Spanish River.....	16,000,000	23,000,000
Collingwood.....	16,000,000	16,000,000
Thessalon.....	16,000,000	25,000,000
John's Island.....	17,000,000	17,000,000
Cache Bay.....	19,000,000	19,000,000
Huntsville.....	15,000,000	12,000,000
Bracebridge.....	14,000,000	14,000,000
Severn.....	5,000,000	5,000,000
Callendar.....	10,000,000	8,500,000
Powassan.....	2,000,000	4,000,000
Bobcaygeon.....	4,000,000	3,000,000
Warren.....	15,000,000	1,500,000
Collins Inlet.....	5,000,000	5,000,000
Other points.....	36,000,000	40,000,000

721,000,000 676,000,000

The output of the mills included in the above table is largely pine, although hemlock and hardwoods might represent about ten per cent. of the cut, thus giving a pine production of 613,000,000 feet.

The cut of the Ottawa Valley manufacturers did not vary much from the previous year. The new mill of Fraser & Company was operated only for a portion of 1903, which accounts for the increase shown last year. The tendency is to curtail operations owing to high cost of logging and of transporting the timber to the mills. The Ottawa Valley production in 1901 was 611,000,000 feet; 1902, 608,000,000 feet; 1903, 562,000,000 feet; 1904, 565,800,000 feet. The cuts of the different mills follow :

OTTAWA VALLEY PRODUCTION.

	1903—Feet.	1904—Feet.
J. R. Booth, Ottawa.....	115,000,000	115,000,000
W. C. Edwards & Co., Rockland and New Edinburgh..	95,000,000	95,000,000
McLachlin Bros., Arnprior..	70,000,000	60,000,000
Hawkesbury Lumber Co., Hawkesbury.....	50,000,000	50,000,000
St. Anthony Lumber Co., Whitney.....	33,000,000	35,000,000
Gillies Bros., Braeside.....	32,000,000	27,000,000
Gilmour & Hughson, Hull...	28,000,000	30,000,000
Hull Lumber Co.....	15,000,000	20,000,000
Gilmour & Co., Trenton....	8,000,000	7,000,000
Pembroke Lumber Co., Pembroke.....	12,000,000	15,000,000
G. H. Perley Co., Calumet..	18,000,000	15,000,000
McLaren & McLaurin, East Templeton.....	27,000,000	20,000,000
James McLaren Co., Buckingham.....	25,000,000	20,000,000
J. R. & J. Gillies, Arnprior...	3,000,000	3,000,000
A. & P. White, Pembroke...	4,000,000	5,000,000
Shepard & Morse, Ottawa...	12,000,000	15,000,000
Fraser & Co., Descheines...	5,000,000	25,000,000
Rideau Lumber Co.....	5,000,000	5,300,000
Davidson & Thackery, Fort Cowlonge.....	5,000,000	3,500,000
Total.....	557,000,000	565,800,000

A large percentage of the Ottawa Valley production is exported to Great Britain, and in view of the unsatisfactory conditions which have prevailed in that market during the past year, it is quite probable that the production will be further curtailed this season.

SHIPMENTS FROM NEW BRUNSWICK BY PORTS, 1903 AND 1904

Table with 3 columns: Port, 1903 Sup. feet, 1904 Sup. feet. Lists various ports including St. John, Dalhousie, Campbellton, Bathurst, Chatham, Newcastle, Richibucto, Buctouche, Sackville, Shediac, Hopewell Cape, Hillsboro, Harvey, and Dorchester.

Total 388,361,705 358,881,893
Decrease in 1904, 29,479,812 feet.

TOTAL TRANS-ATLANTIC SHIPMENTS FROM NEW BRUNSWICK FOR PAST 10 YEARS.

Table with 2 columns: Year, Sup. Feet. Lists years from 1895 to 1904 with corresponding shipment volumes.

DISTRIBUTION OF ST. JOHN, N.B. SHIPMENTS FOR THE YEARS 1903 AND 1904

Table with 3 columns: Port, 1903 Sup. Ft., 1904 Sup. Ft. Lists various ports including Liverpool, Bristol Channel, Barrow, London, Manchester, River Mersey, Glasgow, Greenock, Limerick, Belfast, Sligo, Dublin, Bantry, Londonderry, Drogheda, Australia, Spain, and Other ports.

Total 174,360,562 172,995,507
Decrease in 1904, 1,365,055 feet.

SHIPPERS FROM PORT OF ST. JOHN.

Table with 3 columns: Shippers, 1903, 1904. Lists shippers like W. M. Mackay, A. Gibson Ry. & Mfg. Co., Geo. McKean, and Other shippers.

Total 174,360,526 172,995,507

SHIPMENTS FROM ST. JOHN TO TRANS-ATLANTIC PORTS FOR PAST 10 YEARS.

Table with 2 columns: Year, Sup. ft. deals. Lists years from 1895 to 1904 with shipment values in feet deals.

SHIPMENTS FROM MIRAMICHI TO TRANS-ATLANTIC PORTS FOR PAST 10 YEARS.

Table with 2 columns: Year, Sup. ft. deals. Lists years from 1895 to 1904 with shipment values in feet deals.

SHIPPERS FROM PORTS OF MIRAMICHI IN 1904.

Table with 3 columns: Shippers, Sup. Feet. Lists shippers like F. E. Neale, Snowball Co., W. M. Mackay, D. J. Richie Co., E. Hutchison, G. Burchill & Sons, and Damery & McDonald.

Total 94,500,000

The West Indian and South American markets furnished an outlet for much of the lumber manufactured in Nova Scotia, and the season's operations were therefore fairly satisfactory. The mills in the western part of the province cut almost exclusively for these markets and were operated to their full capacity. Prices were good, but the margin of profit was kept down by the excessive cost of production and the large quantity of lumber that was sent forward during the latter part of the year.

The export of lumber from Nova Scotia to Europe also is known to have been quite large. Although complete returns could not be obtained, the following table will permit a comparison of the shipments for two years from Halifax:

EUROPEAN SHIPMENTS FROM HALIFAX, N.S.

Table with 3 columns: Name, 1903-feet, 1904-feet. Lists shipper names like W. Malcolm Mackay, Alfred Dickie, Isaac H. Mathers, T. G. McMullen, Smith, Tyrer & Co., G. W. Henderson, and C. J. Willis & Co.

Total 65,750,000 51,800,000

The cut of logs this winter is being curtailed in both New Brunswick and Nova Scotia.

BRITISH COLUMBIA.

Depression characterized the lumber and shingle business of British Columbia throughout the entire year. The unfavorable conditions which existed are well known to the trade generally. A large number of new mills were built in the year 1903, largely in anticipation of supplying the demands of the Northwest. The mill capacity soon became greater than the absorbing power of the market and overproduction followed, the situation being further aggravated by large importations of low grade American lumber. Many of the Canadian manufacturers closed down their mills rather than operate them and sell the lumber at sacrifice prices, and towards the close of the year the conditions became slightly improved, but not until some of the smaller mills had been forced into bankruptcy.

The cargo shipments from British Columbia were confined to two mills, the total for the year showing a falling off of 20,000,000 feet. The shipments to South Africa show a very striking decline, being nearly 19,000,000 feet less than the previous year. The exports to the United Kingdom declined 100 per cent., while there was an increased volume of trade with Australia and South America. Statistics of the export trade are given below:

CARGO SHIPMENTS OF LUMBER FROM BRITISH COLUMBIA IN 1904.

Table with 3 columns: Vessel, Destination, Ft. B.M. Lists vessels like Hydra, Admiral Tegethoff, Khyber, Longships, James Johnson, Procyon, T. P. Emigh, Schurbek, Antofagasta, Olivebank, Admiral Tegethoff, W. H. Talbot, Lindfield, Poltalloch, and Guerveur.

FROM HASTINGS.

Table with 3 columns: Vessel, Destination, Ft. B.M. Lists vessels like Andre Theodore, Eskasoni, Chile, Peleus, Aorangi, Tydeus, Adolph, Linlithgowshire, Miowera, and Ping Suey.

Table with 3 columns: Vessel, Destination, Ft. B.M. Lists various vessels and their destinations including Moana, Sussex, Belford, Agamemnon, Aorangi, Ningchow, Ningchow, Lottie Bennett, Americana, Miowera, Hyson, Calchas, Manuka, Tartar, County of Kinross, Donna Francisca, Aorangi, Stentor, Hawthornbank, Onfa, Miowera, Manuka, Inverness, Harold, Aorangi, Halewood, Telemachus, Deucalion, Miowera, Balboa, Moana, Tartar, Yang-Tsze, Pallas, Lottie Bennett, and Falklandbank.

Total 42,199,777

SHIPMENTS BY COUNTRIES.

Table with 3 columns: Country, 1903 Ft. B.M., 1904 Ft. B.M. Lists countries like South Africa, United Kingdom, South America, China and Japan, Australia, Calcutta, United States, Fiji Islands, and France.

Total 60,630,380 42,199,777

CARGO SHIPMENTS FROM BRITISH COLUMBIA FOR THE PAST 10 YEARS.

Table with 2 columns: Year, Feet B.M. Lists years from 1895 to 1904 with shipment values in feet B.M.

WHOLESALE LUMBER DEALERS' MEETING.

The thirteenth annual meeting of the National Wholesale Lumber Dealers' Association of the United States will be held at Philadelphia March 1st and 2nd. The special committee on arrangements appointed to take full charge of the banquet and entertainment and select the speakers, etc., is composed of Robert C. Lipincott, George F. Craig and Henry C. Riley, all of Philadelphia; Lewis C. Slade, Saginaw; Lewis Dill, Baltimore, and J. M. Hastings, Pittsburg. Secretary Perry, of New York, has been to Philadelphia several times to consult with the committee and advises that the prospects for a large delegation are good. Retail associations and allied organizations have been invited to send representatives and various matters of importance to the lumber interests will be up for consideration.

ARTISTIC AND INSTRUCTIVE.

Mr. J. C. Schlieauf, West Lorne, Ont., writes: 'Let me congratulate you on your 25th Anniversary Number. It is both artistic and instructive. Pray you may continue to progress is the wish of one of your oldest subscribers.' Mr. Schlieauf in a postscript adds that he started his mill in 1867 and it cuts good lumber yet.

ANNUAL TIMBER MARKET DIAGRAMS

Showing the Periodical Estimates of the Duration of Supply at London, England, in Comparison with the Averages at the Same Time in the Previous Five Years. Compiled by Messrs. Foy, Morgan & Company.

CANADIAN PINE.

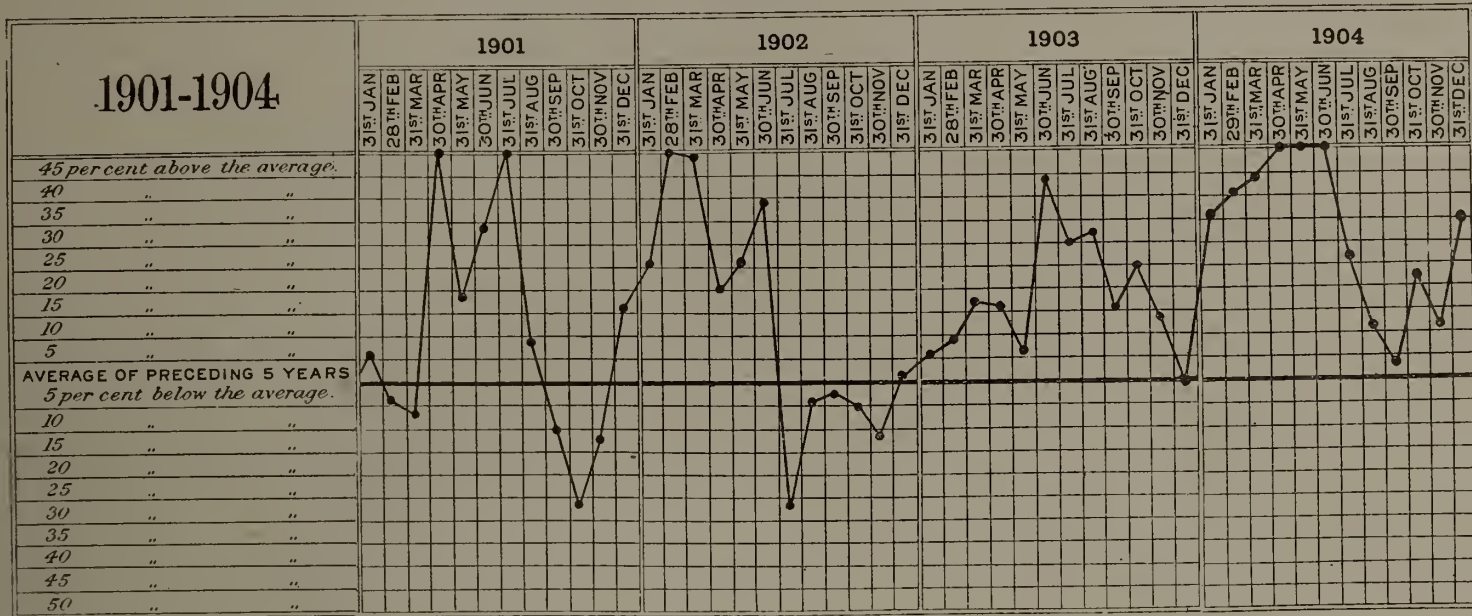

CANADIAN SPRUCE.

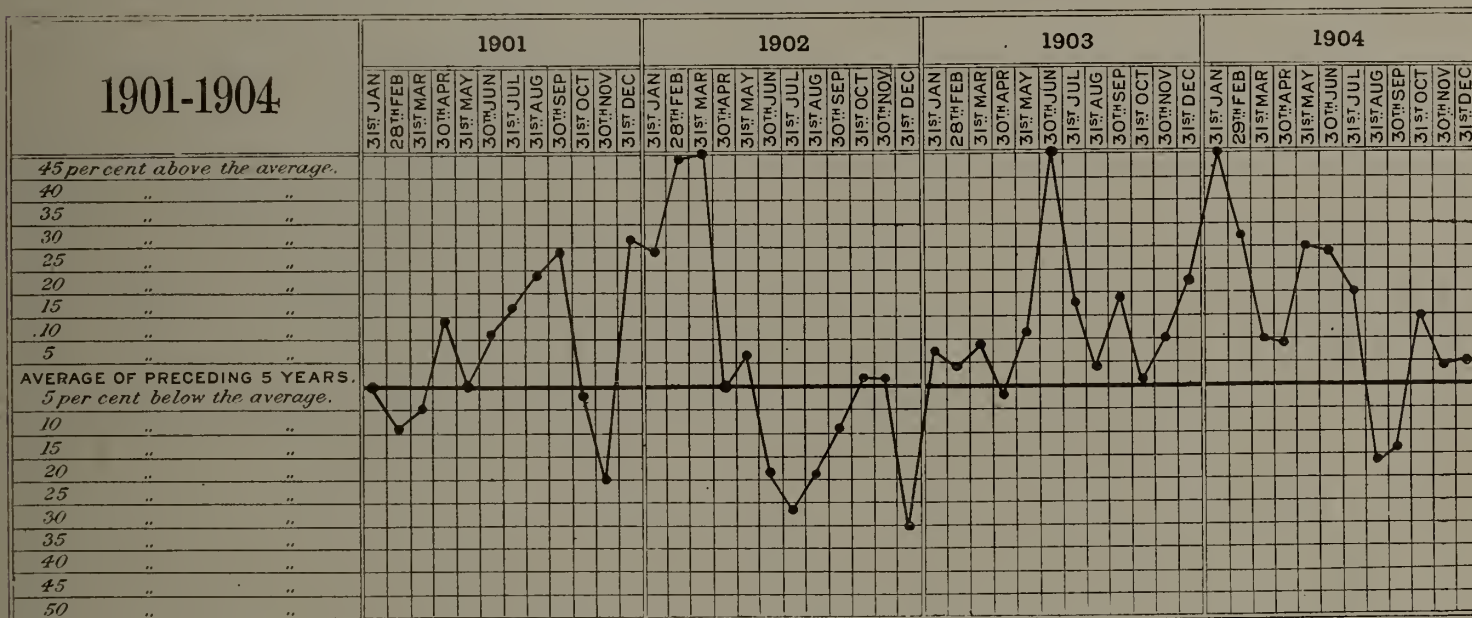

DEALS (FIR)

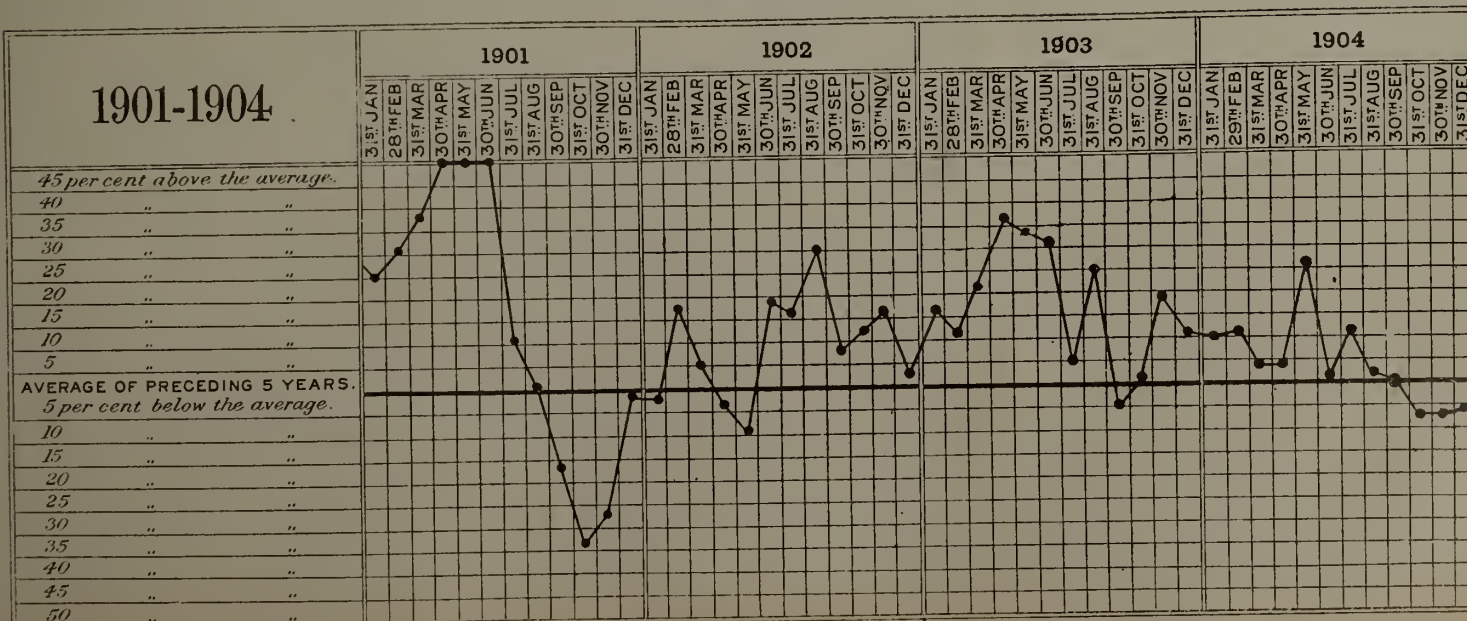

THE Canada Lumberman

AND WOOD-WORKER

(Monthly and Weekly Editions—One Dollar Per Year.)

PUBLISHED BY

The C. H. Mortimer Publishing Company
of Toronto, Limited,

CONFEDERATION LIFE BUILDING, TORONTO

BRANCH OFFICES:

38 ALLIANCE BUILDING, MONTREAL
720-721 UNION BANK BUILDING, WINNIPEG
21 GREAT ST. HELENS, LONDON, E. C.

The LUMBERMAN Weekly Edition is published every Wednesday, and the Monthly Edition on the 1st day of every month.

TERMS OF SUBSCRIPTION:

One Copy, Weekly and Monthly, One year, in advance, \$1.00
One Copy, Weekly and Monthly, Six Months, in advance, \$0.50
Foreign Subscription, \$2.00 a Year

ADVERTISING RATES ON APPLICATION.

THE CANADA LUMBERMAN AND WOOD-WORKER is published in the interest of and reaches regularly persons engaged in every part of Canada in the lumber, wood-working and allied industries. It aims at giving full and timely information on all subjects touching these interests, and invites free discussion by its readers.

Special care is taken to secure for publication in the WEEKLY LUMBERMAN the latest and most trustworthy market quotations throughout the world, so as to afford to the trade at home and abroad information on which it can rely in its operations.

Advertisers will receive careful attention and liberal treatment. For manufacturing and supply firms wishing to bring their goods to the attention of owners and operators of saw and planing mills, wood-working factories, pulp mills, etc., the CANADA LUMBERMAN AND WOOD-WORKER is undoubtedly the most direct and profitable advertising medium. Special attention is directed to "WANTED" and "FOR SALE" advertisements, which are inserted in a conspicuous position on front page of the Weekly Edition.

BUSINESS FAILURES.

The analysis of the causes of business failures appearing in a recent issue of Bradstreet's is very interesting, and would seem to afford lessons which might be applied with advantage. The number of failures in Canada last year was 1,175, with assets of \$4,137,418 and liabilities of \$10,019,311. Of these failures, 62.2 per cent. are attributed to lack of capital. Incompetence, irrespective of other causes, was responsible for 14.2 per cent., and fraudulent disposition accounted for 8.4 per cent. Specific conditions comes next in order, with 5.3 per cent. credited to this cause. Inexperience and neglect accounted respectively for 3.1 per cent. and 2.9 per cent. Other causes were unwise credits, failures of others, extravagance, competition and speculation. The statistics show that 93.3 per cent. of the failures were due to the faults of the traders themselves.

The number of failures in the United States was 10,417, of which 22.9 per cent. are classed as beyond the control of the individual himself and 77.1 per cent. as his direct responsibility.

The attempt to do business on an insufficient capital is the one thing to be most carefully guarded against, as it is shown to be by far the most fatal single cause of financial disaster. Incompetence is not nearly so ruinous, but sufficiently so to impress upon the mind of a person about to engage in business the necessity of knowing that business thoroughly. Associated with specific conditions are such occurrences as fires, floods, crop failures, and other causes beyond the immediate control of the person.

The facts given above should be an inspiration to all persons to devote strict attention to the management of their business. Failures are evidently due chiefly to causes within the control of the individual, and may therefore, in most instances, be prevented. To a

large extent the man who ventures on the sea of commercial life is "the architect of his own fortune."

INSURANCE FOR RETAIL YARDS.

The Western Retail Lumbermen's Association took an advanced step at their meeting in Winnipeg last month, the purpose of which is to secure insurance for retail yards upon more equitable terms. It is proposed to establish an insurance department in connection with the association, to be under the control of the board of directors. This decision is the result of the exorbitant rates which the insurance companies have charged on lumber yards. The average premium has been about 2½ per cent., which rate is applicable to saw mills and lumber risks generally, whereas it is claimed that investigation will show that the retail yards are entitled to a much lower premium on account of their comparative freedom from fire. Basing calculations upon the results accomplished by a mutual company insuring retail yards in the United States, and allowing a large safety factor, the Western Retail Lumbermen's Association have placed their premium at one per cent., which will mean a considerable saving to the five hundred yards constituting their membership.

RECIPROCITY IN LUMBER.

Let not the above title inspire false hopes in the hearts of any lumbermen who may long for the realization of such a condition, for it may be far distant. This much may be said, however, that the day is drawing nearer, and sooner or later reciprocal trade relations will exist between Canada and the United States in respect to lumber. These remarks are prompted by recent rumors, emanating from channels which suggest reliability, that negotiations are under way which may result in the abolition of the present American duty on Canadian lumber.

It is improbable that the United States Congress will make any radical changes in the tariff at the present session, as conditions in that country are comparatively prosperous, but it is argued that there are reasons which have not previously existed for removing the lumber duty. One is the increasing importance of the Canadian market. The Eastern States have always been in favor of free lumber, and now they are supported by many of the manufacturers of southern pine, who wish to retain their trade in Canada, and by dealers in Michigan, Ohio, and other states who are dependent largely upon the Ontario mills for their supply. The manufacturers of Minnesota and of Washington and other western states are also counting largely upon the prospective demand in the Canadian Northwest and would probably prefer the abolition of the American duty rather than be shut out of the Canadian market by a duty. With these interests, including the many influential Americans who now own and operate mills in Western Ontario, arrayed in favor of free lumber, it would not be surprising if a reciprocal arrangement should be reached between the two countries.

The defeat in Ontario of the Liberal Government, under whose administration was

enacted the law prohibiting the export of saw logs from the province, will not endanger that legislation, which had also the support of the Conservative party at the time of its adoption. Public sentiment is strongly opposed to the repeal of the law. Therefore, free access to our timber except for manufacture within the province is extremely unlikely to form the basis of any negotiations affecting lumber duties.

DEMURRAGE CHARGES.

The feeling existing between the railroad companies and the shippers on the subject of demurrage has not been the most friendly for some time past, and recent occurrences have not tended to improve the situation. There is no disposition on the part of the shippers to complain about the principle of demurrage, for it is recognized that its application must facilitate and quicken transportation, but it is contended that the charges are not fairly exacted and that equitable treatment has not always been received. Many shippers of lumber have experienced great difficulty in dealing with the railways on this question, and at a recent meeting in Toronto a strong protest was entered against the manner in which the regulation is being administered.

As an illustration of the despotic methods which have been adopted by the railroad, a case was cited where they had entered the yard of a local lumber firm at night and removed several cars of lumber, the demurrage charges on which had formed the basis of an unsettled dispute. Wiser counsel prevailed, however, and, presumably on instructions from the supreme authority, the cars were returned within a short time.

It is a question whether the present demurrage charge of one dollar per day is not too high and whether, in view of the increased capacity of many of the cars now used, the time allowed before such charge becomes effective should not be extended. But, granting the fairness of the law in these respects, the absence of any reciprocity regulations constitutes a weak feature of the present arrangement from the standpoint of protection for the shipper. The shipper is penalized for neglect or inability to promptly load or unload cars of merchandise; why, then, should not the railroads be compelled, under similar penalty, to furnish desired cars to shippers as well as deliver merchandise to its destination within a given time?

The whole matter will likely be brought before the Railway Commission, as we understand the Transportation Department of the Canadian Manufacturers' Association is now engaged in collecting specific information. We would recommend for their consideration the Virginia reciprocal demurrage law. It provides that a shipper must load or unload promptly or pay a penalty of one dollar per day, also that the railroad companies shall furnish cars within a specified time or be subject to a similar penalty. This law has stood the legal test in Virginia and is being copied by other states. It is fair to both shipper and railroad, and possesses the very commendable feature of prohibiting the railroads from boycotting one commodity in favor of another, a restriction which will appeal to the lumber trade, for we fear that in the past lumber has in more than one sense been "side-tracked."

THE Wood-Worker and Retailer

ANNUAL CONVENTION OF WESTERN RETAIL LUMBERMEN

The fourteenth annual convention of the Western Retail Lumbermen's Association was held in Eureka Hall, Winnipeg, on January 18 and 19. A goodly representation of the members was in attendance and a very large amount of business in connection with the association was disposed of in the two days.

The convention was the largest in the history of the association and the business was con-

dorf; J. H. Lyon, Munster, Sask; J. B. Ross, Miniota; David Ross, Miniota; A. Dunlop & Sons, Dunrea; J. A. Thompson, Winnipeg; A. McKinney, Winnipeg; B. J. Hay, Arcola; J. H. Hughes, Brandon; M. Craig, Strathcona; Wm. Ansley, Drinkwater; Wm. Irwin, Newdale; S. Caswell, Rathwell; L. D. Smith, Arnaud; D. L. Lincoln, Winnipeg; J. E. Parrott, Saltcoats; F. McPherson, Binscarth; Geo. Rogers, Lethbridge; A. H. Foulds, Carnduff;

Estlin, Melita; J. S. Lougheed, Deloraine; J. E. Walker, Bocannville; Allan W. Stewart, Thornhill; W. R. Serkan, Niverville; E. A. Halston, Winnipeg; H. C. Graham, Carroll; A. B. McLelland, Brandon; A. M. High, Killarney; S. Fargey, Belmont; R. W. Gibson, Winnipeg; G. Silvester, Elkhorn; R. S. Banbury, Wolseley; A. Renuart, St. Pierre; Jos. Conway, Crystal City; R. J. Stewart, Holland; W. McManus, Winnipeg; J. H. Bolton, Darlington; P. J. Friesen, Gretna; W. Armstrong, Portage la Prairie; G. B. Housser, Portage La Prairie; I. D. Kennedy, Brandon.



MEMBERS IN ATTENDANCE AT ANNUAL CONVENTION OF THE WESTERN RETAIL LUMBERMEN'S ASSOCIATION, WINNIPEG, JANUARY 18, 1905.

ducted with the utmost harmony and accord, while an increased number of the members participated in the various discussions.

The convention opened at 3.30 p. m. on Wednesday, Mr. J. L. Campbell, the president, being in the chair.

The following members were present: J. L. Campbell, Melita; D. McNaught, Rapid City; W. J. Robertson, Cartwright; J. H. Jones, Rosebank; G. F. Robertson, Crystal City; A. W. Reiner, Steinback; G. A. H. Bonnet, St. Laurent; J. Robson, Treherne; J. W. Ross, Whitemouth; Tom Mellard, Cypress River; W. W. Ireland, Carberry; E. Wankel, Oak River; E. Greenshaw, Shoal Lake; G. E. Davidson, Manitou; T. R. Preston, Glen Ewen; James Foreman, Alexander; Dan Kuss, New-

A. Shaw, Miami; Thos. Hamilton, Crandell; A. E. Downey, Swan Lake; T. L. Arnett, Souris; W. H. Hunt, Yellow Grass; D. E. Sprague, Winnipeg; Jos. Baril, St. Jean Baptiste; W. A. Morkill, Dominion City; J. Hanbury, Brandon; J. C. Henderson, Humboldt; M. C. Cornelinson, Starbuck; J. J. Smiley, Manor; R. G. Marling, Pense; J. R. Bunn, Milestone; A. Lemay, St. Boniface; S. McClain, Carman; F. H. Dagg, Holland; J. McCutcheon, Glenboro; W. L. Burley, Neepawa; W. Robertson, Rat Portage; J. C. Graham, Winnipeg; W. F. Ramsay, Killarney; A. S. Brown, Saskatoon; R. Lockhart, Fort Francis; D. K. McLeod, Francis, Assa.; M. Quennelle, Wauchope; D. E. Fraser, Kenton; B. Harvey, QuAppelle; Tom Markes, Plum Coulee; A. B.

The chairman delivered a short address of welcome, after which the minutes of the last meeting were read and adopted. Then followed the president's address, which was received with cheers.

PRESIDENT'S ADDRESS.

Gentlemen of the Western Retail Lumbermen's Association:—It is with more than ordinary pleasure that I greet you at this fourteenth annual meeting of our Association. With almost a single exception during the last year matters pertaining to the welfare of the Association have been going on in the even and satisfactory tenor of their way. I refer to the honorary members of the West, who, for reasons of their own, some of which perhaps beyond their control, have seen fit to withdraw in the meantime from our Association.

I believe I am justified in assuring you that the practical relationship that existed between us and them in past years will not be materially changed. Those con-

ditions which in the past have been found mutually advantageous will be observed on both sides with the same loyalty as heretofore, not because of any arbitrary bonds, but because to do so will conduce to the greatest business advantage of both. And after all, these are the conditions most stable and best suited to overcome obstacles. In consequence of these withdrawals, changes in the constitution and by-laws will become necessary. Your Board of Directors have revised these, in what appear to them necessary respects, and they will be submitted to you for your approval or amendment and final confirmation.

Your committee appointed to enquire into the feasibility of forming a mutual fire insurance scheme for the protection of lumbermen of your Association, have given the matter very diligent and intelligent consideration, with results that I am sure will be gratifying to you. Reports on this subject will be submitted for your consideration during this meeting. You will be asked to take what action in your wisdom seems best to conduce to your interest.

I regret that the early prospects of an abundant harvest have not in all cases been realized. The disappointment has been offset in some measure by unusually high prices; still the failure had a diminishing effect upon trade and held building operations in the country somewhat in abeyance. Taking trade all in all, I think we may say we have had a fairly average year.

Immigration, which has been so marked a feature of recent years, has been well maintained. The outlook for a still greater influx, especially from beyond the seas, is exceedingly bright, and promises to be much in excess of former years. We cannot fail to reap our share of the benefits accruing from these large additions to our population and consequent development of our agricultural resources.

You have a statement of receipts and expenditures for the past year showing a comfortable balance on the right side. I am sure you will be gratified at the very happy state of our finances.

The secretary-treasurer having a report setting forth in interesting detail the more important matters relating to the business of the past year, I shall not further trespass upon your time.

But I cannot close without some reference to your action at the last annual meeting. I never was more anxious to attend a meeting than I was that one, but unfortunately I was prevented by a serious illness from which I had but tardy recovery. Notwithstanding my absence, you saw fit in your goodness to do me the honor of re-election. I need not attempt to tell you how deeply affected I was by this manifestation of your good will. Owing to circumstances of health necessitating my absence from the Province, I regret that I have not been able to give that attention to your affairs which their importance demanded, but nevertheless I trust you will accept my expression of high appreciation in which I regard the delicate and effective compliment you paid me.

I wish you at this time a pleasant and profitable meeting and hope that the future has in store greater advantages for the welfare of this Association and its members than even the past year has produced.

J. L. CAMPBELL.

The following report was submitted by the secretary-treasurer, Mr. Issac Cockburn:

SECRETARY-TREASURER'S REPORT.

Mr. President and Gentlemen, Members of the Western Retail Lumbermen's Association: I am glad to meet you here assembled at this, the fourteenth annual meeting of this Association, and it is with unfeigned pleasure that I extend to you a happy greeting on this auspicious occasion. And you, Mr. President, I can assure you it is much rejoicing to have you with us, restored to health and vigor from your lengthened severe illness, and again worthily filling the chair as of yore, and I am sure I voice the united sentiment of this meeting in expressing grateful satisfaction to know that your recovery of health has been so complete.

It was thought by the directors and myself that after the experience of the stormy weather of March last and in view of the expressed wish of some members to bring on the meeting as early as possible after the first of January, it might be well to call the meeting at this

time, and I trust the decision meets with your approval and convenience.

In making my statement for the year 1904 it is a pleasing duty, as we have continued prosperity, both in an addition to our money assets and an increase of membership.

Our yard membership at present stands at 528 with but few arrears in fees, and the financial statement shows a balance on hand of \$10,903.76.

In further reference to our Association, I need scarcely mention to you that there has been an upheaval amongst our Honorary members during the year, and that to-day we are mostly without Honorary members in the Province of British Columbia.

We began the year under bluster and threatening, and later were confronted with a compact entered into by and between the president and vice-president of the Mountain Lumber Manufacturers' Association and the C. P. R. Company, whereby the wholesale price of lumber was to be exposed to the public by posting up a listed price thereof at all the stations of the C. P. R. This was carried out and doubtless for the purpose of making a thrust upon our retail members, but I am glad to know, contrary to the intention, the effect did not injure the position of the dealer, but rather led up to convincing the buyers that the retail charges were only reasonable, and satisfaction was expressed thereat.

I might recall that in the autumn of 1903, at the instance of our President, I invited the honorary members to a meeting to discuss the problem of impending competition in lumber from Washington State, which was then being offered at a price a good deal less than that of the Canadian product. The meeting took place, but that problem was not dealt with as was expected, and prices remained just where they were for a time. It is true that the price list was reduced somewhat later on but not anything near that of the competition offered by the manufacturers in Washington State. A considerable quantity of material which had been offered for the season's trade of 1903 did not arrive until after the close of the season's business in that year, and such deliveries were consequently carried in stock until the following spring, when a good many dealers were found carrying a sufficient stock for the spring requirements. The spring was late and the retail business continued very dull until the month of June. This state of the trade was disappointing to the manufacturers, who were having an accumulated stock at the mill, and this coming so close after the large demand of the prior season, proved irritating, and very possibly the true facts of the lumber situation were not duly considered by them as they should have been. The result was that some manufacturers had taken upon themselves to sell where they best could regardless of Association members, and complaints were soon reaching me, and when called upon for an explanation, a justification was sought to be made by asserting that the retail members were buying from other than Honorary members. My information as to this was that generally in the West, excepting at Regina, the retail dealers were not buying American lumber in any perceptible quantities, and the charge formulated by the Honorary members in my opinion was exaggerated with the exception of Winnipeg, Brandon and to some extent Regina, and of course at points along Southern Manitoba.

I know that the reciprocal clause was not lived up to by many Honorary members and also by many Active members, and a want of fidelity existed by such on both sides. And while this is true in some cases, I must express a high degree of admiration for the many, both Honorary and Active members, who maintained a due regard for the reciprocal clause of the by-laws, and this in the face of the strong temptation brought before the retail dealer in being able to purchase lumber outside of the Honorary members at less price. Now the point is just this—were the Honorary members remiss in not taking the matter up promptly and meeting the contingency as far as laid in their power? The matter has now well nigh righted itself, but why put the strain upon our Association members so long? It goes without saying that there should and there does exist an affinity of interests and sentiment and good will as between the retail dealers and manufacturers of this country, and the retail dealer will support the home manufacturer in unswerving loyalty, but at the same time a responsibility lies with the manufacturers to see

to it that their range of prices is not too exacting beyond what lumber can be bought for. I have not yet met a retail dealer of our Association who did not express himself as willing to give the Canadian manufacturer a reasonable preference over that of the American product. It must, however, be remembered in these days of keen business competition for trade, that the average person is inclined to be loyal to his business outlook, and it is, after all, the price which makes the sale. This being the case, the retailer who can buy to the best advantage is likely to secure the large share of the business in competition. It is well for the manufacturers to weigh this fact, that when rivalry and competition exist, neither sentiment nor friendship, humanly speaking, can well be expected to hold a retail dealer to buy from any certain wholesaler, when his competitor is buying at a less price. In leaving this matter, I am inclined to the opinion that the majority of our members, including many of the Honorary members, are worthy of commendation for their loyal adherence to our by-laws in the past, and I hope that any changed condition we are now about to make will not be found detrimental to either the wholesale or retail dealer.

I have received letters from the Coast Honorary members intimating their withdrawal from membership in this Association, and they are similar in tone and expression. I regard the letters as having been written in good taste, and we can appreciate the kindly references to our Association and reciprocate with them in expressing a mutual good feeling and welfare.

This, along with the action of the Mountain Lumber Association, leaves us with comparatively few Honorary members in British Columbia, and your directors have taken into consideration the changed conditions which have been brought about by these withdrawals and have revised and rearranged by-laws for our future guidance, which will be submitted to you for adoption. It is thought by some members that the action of making this Association thoroughly retail in its membership will be found to be an advantage in many ways.

Having regard to the question of obtaining amendments to the Lien Law for the Northwest Territories, I have to report that at the convening of the Northwest Council, Mr. Hough communicated with Mr. Haultain expressing the desire to have certain amendments to their Lien Law and sending a draft for the same, which resulted in correspondence between them, Mr. Haultain signifying his approval of making such change. I followed this up by arranging a deputation composed of Mr. Finlay, a member of the Northwest Council, the Rev. Mr. Rogers, of Lethbridge, Mr. Bunn, of Milestone, and Mr. Duncan of Regina, and I believe some progress would have been made had not the Council suddenly adjourned to take part in the Dominion election.

In the matter of the Manitoba Lien Law, a good deal of discussion has been had with Mr. Hough, and he has prepared some amendments which would improve the act materially.

The matter was further brought up for discussion by the Directors at a meeting which was attended by several members, and after a full discussion, a resolution was passed naming a committee to take the matter up with the Government, said committee to be composed of Messrs. Sprague, Hanbury and Hough, with power to add others similarly interested with yourselves.

Then again, in the matter of forming a mutual lumber fire insurance company, I might say that to more fully enquire into the details of the working of an Association of this kind, I invited Mr. Thompson to accompany me to Minneapolis, where we discussed with the secretary and assistant secretary of the Retail Lumbermen's Association there, their experience in conducting their fire insurance association. We met with the utmost courtesy on the part of them both, and we are certainly under much obligation to them for the very kind attention given us and for furnishing us with much detailed information.

Just a word in conclusion. I have had some experience in the manufacture of lumber, as many of you know, and am inclined to be observing when passing through a lumber yard. During last summer I noticed in some instances that a good deal of the one-inch boards were too thin. At one yard the boards barely averaged $\frac{3}{4}$ of an inch and the manufacture of one firm was only $\frac{11}{16}$ inch. It does appear to me that an inch board

should have that thickness, less the necessary shaving in surfacing. This is a matter I think should be looked into in the interests of your customers, and there is no doubt that the farmers want a strong board. There is plenty of competition in the manufacture of lumber to enable you to procure such lumber as you want.

I have now to return thanks for the kind assistance received from the Board of Directors and to the Vice-President for the good counsel received from him in asking his guidance in matters submitted to him, and to the President for his uniform interest in the association and his able assistance.

Mr. D. E. Sprague moved, seconded by Mr. Robson, that the president's address and the secretary-treasurer's report be received and adopted, and that they be printed and circulated among the members of the association.

The advent of several boxes of cigars, donated by Messrs. Merrick, Anderson & Company, of Winnipeg, was warmly welcomed. While the cigars were being passed around, the president, Mr. Campbell, took occasion to pay tribute to the work of the CANADA LUMBERMAN and to its popularity amongst the lumbermen.

The revision of the by-laws was then considered and it was decided that in future the association should consist entirely of retail lumbermen. The necessary changes in the by-laws were made accordingly.

Some of the gentlemen present protested against the admission to the association of certain so-called dealers who carried practically no stock on hand and yet had all the privileges of membership. They were assured that the association was doing all it could to keep up the standard along that line.

Thursday morning the meeting began promptly on time. Mr. J. H. Thompson and the secretary-treasurer, Mr. Cockburn, having visited the mutual fire insurance companies in connection with the lumbermen's associations in the United States, reported that they found them highly prosperous and of great benefit to the lumbermen by cheapening the cost of insurance. They therefore strongly recommended the organization of an insurance company in connection with the Western Retail Lumbermen's Association. The matter was carefully considered and it was decided to adopt the recommendation and to establish a company to be conducted along similar lines to the one in Minneapolis. The necessary funds were appropriated for the purpose of organizing such a company and a committee was appointed to look after the work.

The election of officers of the association for the coming year resulted in the re-election of Mr. J. L. Campbell as president and Mr. D. E. Sprague as vice-president. Two vacancies on the board of directors were caused by the expiration of the term of office of Mr. W. H. Duncan, of Regina, and Mr. W. W. Ireland, of Carberry. These gentlemen having declined re-nomination, their places on the board were filled by Mr. J. R. Bunn, of Milestone, and Mr. D. L. Lincoln, of Winnipeg.

The following resolution was then adopted: Moved by Mr. John Hanbury, seconded by Mr.

D. McNaught, that the thanks of this meeting be tendered to Messrs. Merrick, Anderson & Company for so kindly supplying us with cigars, and to the CANADA LUMBERMAN for the very useful gift of a lumber rule to each member of the association, and that a copy of the resolution be sent to each of the above firms. Carried.



BIG EVENT IN TORONTO.

Walter C. Laidlaw, Supreme Arcanoper, announces a special Hoo-Hoo concatenation in Toronto on Friday evening, February 10th, the meeting place being McConkey's Restaurant, King street west. The Toronto members are leaving no stone unturned to make the gathering one which will outshine anything yet known in Hoo-Hoo, and there is every reason to believe that the high standard which they have set will be reached. Visitors may be assured of every hospitality and an enjoyable time. Come and bring a candidate with you.

THE GALT CONCATENATION.

The first concatenation held by the new Vicegerent, Donald Ferguson, of London, took place in the lodge rooms of The Elks at Galt on December 16th last, with the following officers:

- Vicegerent Snark—Donald Ferguson.
- Scrivenoter—Oscar H. Vogt.
- Senior Hoo Hoo—Ward Sutherland.
- Junior Hoo Hoo—J. G. Cane.
- Bojum—T. Fred Shurly.
- Arcanoper—J. Chas. Dietrich.
- Custocation—W. J. MacBeth.
- Gurdon—W. J. Lovering.
- Jabberwock—Geo. H. Belton.

Assistants—W. C. Laidlaw (Arcanoper of the Supreme Nine), W. A. Hadley, N. Fleischauer, A. Dennis, Jno. Barry, G. Kastner, M. P. Kinsella, H. S. Dunbar, Fred Lawrence.

The following candidates were well taken care of by the officers: L. McGill Allan, Toronto; Wm. B. Banford, Burlington; James "Scotty" Buchanan, Galt; Jas. H. Cowan, Galt; J. C. Deitrich, Galt; Percy G. Deitrich, Galt; W. H. Fisher, Preston; David "Golath" Easson, Stratford; James E. Gardner, Galt; Jno. O. Gorman, London; Frank W. Lilley, Clarence, N.S.; Duncan Murray, Galt; H. R. O'Reilly, Galt; Fred Douglas Palmer, Galt; William S. Radcliffe, Toronto; Alfred C. Roilofson, Galt; Thos. M. Ruston, Stratford; Sidney R. Sheldon, Galt; C. J. Shurley, Galt; Robt. J. Spalding, Galt; C. A.

Stephenson, Galt; R. D. Stewart, Guelph; F.T. Strong, Galt; James B. Warnock, Galt.

After the initiation an adjournment was made to the Grand Hotel for an interesting programme on the roof, in which about seventy-five members and kittens took part. Vicegerent Snark Ferguson made a capital toast master. The toast to the King and President of the United States was responded to by Captain Stevens, Syd. Sheldon, E. J. Ryan and Frank J. Lillie. F. D. Palmer replied for the Hoo-Hoo of Galt and Walter Laidlaw for the order of Hoo-Hoo. "The Lumber Interests" was responded to by W. J. MacBeth, M. P. Kinsella and G. Kastner. "The Pioneer Hoo-Hoo" brought a response from J. G. Cane, who was initiated in Boston some years ago, Mr. Hadley, of Chatham, and Mayor Watson, of Mull. J. O. Gorman, W. H. Fisher and Jas. Cowan answered for the "Kittens." "The American Hoo-Hoo" was responded to by Messrs. Dennis, Ten Eyck and Radcliffe.

Messrs. Kastner and Lillie in toasting Messrs. Shurly & Dietrich, moved a hearty vote of thanks for their hospitality. Oscar H. Vogt in reply told the representatives that he spoke for the largest saw factory in the world. R. B. Elgie and Jack Jarvis responded for the "Ladies," and Ward H. Sutherland for "Wood Working Machine Shops of Galt." A concluding toast to "The Host and Hostess" brought the proceedings to a close.

HOO-HOO IN WESTERN CANADA.

The Hoo-Hoo Order is becoming very popular in Western Canada, and the membership is growing rapidly. At Winnipeg on January 18th a concatenation was held in the Eureka Hall, when a class of thirty-one kittens were initiated.

After the initiation ceremonies, which lasted until twelve o'clock, all repaired to the Metropolitan Hotel, where a splendid banquet was held. About 100 persons sat down to the table, with D. Boyce Sprague as chairman. Songs, speeches and stories combined to make the meeting the most memorable in the history of the order.

The following officers have been elected for the current year: Snark of the Universe, D. Boyce Sprague; Senior Hoo-Hoo, James Ovas; Junior Hoo-Hoo, W. D. Chandler; Bojum, P. R. Case; Scrivenoter, Jey Spencer; Jabberwock, William Tomlinson; Custocation, Harold Sprague; Arcanoper, Robert Jones; Gurdon, Daniel McDonald; Official Barber, Daniel Lincoln.

British Columbia has been invaded by Hoo-Hoo. George W. Campbell, of Vancouver, has been appointed Vicegerent and he expects to hold some record concatenations in the near future. Ex-Vicegerent Housser, of Portage la Prairie, Man., is in favor of holding a meeting at Regina.

Uncle Sam would not allow his battleships to be babbitted with inferior babbitt metal. New Battleship "Nebraska" is lined with Syracuse Babbitt. Always specify best. It is cheapest in long run.

SYRACUSE SMELTING WORKS

MONTREAL NEW YORK SEATTLE

...BUCKEYE SAW M'FG. CO...

MANUFACTURERS OF

High-Grade Saws

Quick and careful work on Repairing. All kinds of Mill Supplies.

REYNOLDS BROS., Proprietors
267 N. Water Street, COLUMBUS OHIO.

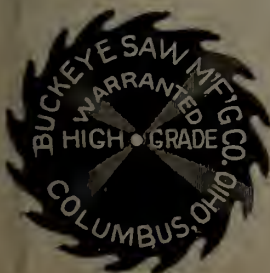

6 CANADIAN OIL CO. LIMITED
STRACHAN AVENUE TORONTO, ONT.

TO LUMBERMEN THE DOMINION OVER: OUR TRADE WITH SAW-MILLS

Has been large and satisfactory. We again solicit your orders for the season of 1905.

Our Agents will call with "STERLING"

Cylinder, Engine, Dynamo, Machine, and SPECIALTY Oils, Greases, Packing, Waste, Babbitt Metal, Ready Mixed House Paints, Varnish, Red and Black Roof Paint, Smoke Stack Black for Boiler Fronts and Saw Mill Refuse Burners, White Lead, etc.

BRANCHES: Petrolia, Ont. Hamilton, O. Moutreal, P. Q. Vancouver, B.C.
London, Ont. "Soe," Ont. Winnipeg, Man. St. John, N. B.
Halifax, N. S.

'STERLING'

OIL

'STERLING'

OIL

PUBLICATIONS.

The A. Sanford Logging Tool Company, of Oshkosk, Wis., have issued Catalogue "H," showing their complete line of lumbering tools, lumber carts and other specialties. They advise us that they will be glad to mail a copy to any lumberman upon request.

The 1905 issue of E. C. Atkins & Company's "Saw and Saw Tool Catalogue and Sawyer's Handbook" is larger in size and greatly improved in many respects over any previous issue. The book contains valuable information on the care of saws and will be appreciated by all saw mill operators, who will receive a copy for the asking.

William Rider & Son, Limited, Aldersgate St., London, Eng., have favored us with a copy of "Webster's Forester's Diary and Pocket Book," which con-

tains, amongst other useful information, concise remarks on forestry for each month of the year; rules for planting, thinning, pruning, timber measuring and valuing, etc. The book is very neat and convenient and sells for two shillings and sixpence.

LUMBER INSURANCE.

The report of the directors of the Lumber Mutual Fire Insurance Company, of Boston, which recently reached us, makes a very favorable showing. The insurance in force at the close of the year 1904 was \$51,671,858.15, a gain for the year of \$1,400,564.44. The net cash surplus above all liabilities is put down at \$117,877.61. The dividend to policy holders was increased from 30 to 33 1/4 per cent. of the net premiums received on all policies issued on or after January 1st,

1904. The plan of business, as laid down by the company, is as follows:

- 1st. To insure lumber dealers, lumber manufacturers, woodworkers and other kindred lines of business, direct with the assured not through local agencies.
 - 2nd. To reserve such part of the profits in the net cash surplus as will guarantee such indemnity—and prompt payment of every loss.
 - 3rd. To pay a cash dividend on each policy at its termination as may be voted by the directors.
 - 4th. To inspect all risks and recommend improvements which will prevent fires, thereby reducing cost of insurance.
 - 5th. To furnish details of construction of mills and factories which will merit lowest rate of insurance.
- There were returned to policy holders last year \$35,025.51 in dividends, and it is estimated that the returns this year will be about \$55,000.

DO YOU USE

ANY OF THE FOLLOWING IN OR ABOUT YOUR

Shipping Room or Factory?

<p>A</p> <p>Adzes, Coopers' Ash Cans Auger Bits Axes, Fire</p> <p>B</p> <p>Back Saws Barber's Braces Barrel Hatchets Bench Dusters " Rules Bits, Auger " Expansion " Screwdriver Blades, Saw, Turning Blind Man's Rules Box Chisels " Hooks " Scrapers " Strapping " Trucks Boxes, Mitre Boxing Hammers Boxwood Rules Braces, Barber's " Spofford's Brackets, Fire-Axe Bradley Stencil Machine Brushes, Marking " Stencil Buckets, Water</p> <p>C</p> <p>Cans, Ash Carpenters' Clamps " Pencils " Squares Carpet Shears</p>	<p>Carpet Trucks Chisels, Box " Fitmer " Ripping Clamps, Cabinet " Carpenter's " Iron " Piano Claw Hammers " Hatchets Compass Saws Coopers' Adzes " Drivers Cotton Mcps Crate Openers Crayons, Marking Cut Nails</p> <p>D</p> <p>Dividers, Winged Drawing Knives Drivers, Coopers' Dusters, Bench</p> <p>E</p> <p>Expansive Bits</p> <p>F</p> <p>Factory Trucks Fibre Pails Fire Axes Fire Axe Brackets " Hooks Firmer Chisels Frames, Hack Saw</p> <p>H</p> <p>Hack Saw Frames Hammers, Boxing " Claw</p>	<p>Hammer Nail Hand Saws " Screws Handles, Mop Hatchets, Barrel " Claw " Shingling Hooks, Box " Fire</p> <p>I</p> <p>Ink, Stencil Iron Clamps</p> <p>K</p> <p>Keyhole Saws Knives, Drawing</p> <p>L</p> <p>Lanterns Lumber Pencils</p> <p>M</p> <p>Machine, Stencil, Bradley Mallets, Oval " Ring " Round " Square Marking Brushes " Crayons " Pots Mitre Boxes Mop Handles " Wringers Mops, Cotton</p> <p>N</p> <p>Nail Hammers " Pullers Nails</p>	<p>Needles, Packing</p> <p>O</p> <p>Openers, Crate Oval Mallets</p> <p>P</p> <p>Packing Needles Pails, Fibre Pencils, Carpenters' " Lumber Pipe Wrenches Plates, Stencil Pots, Marking Pullers, Nail</p> <p>R</p> <p>Ring Mallets Ripping Chisels Round Mallets Rules, Bench " Blind Man's " Boxwood</p> <p>S</p> <p>Saw Blades, Turning " Frames, Hack Saws, Back " Compass " Hack " Hand " Keyhold " Turning Scoops Scrapers, Box Screws, Hand Screwdriver Bits Screwdrivers Shears, Carpet " Tailors'</p>	<p>Shingling Hatchets Shovels Spofford's Braces. Sprinklers Square Mallets Squares, Carpenters' " Try Steel Clamps Stencil Brushes " Ink " Machine, Bradley " Plates Sticks, Yard Store Trucks Strapping, Box</p> <p>T</p> <p>Tailors' Shears Trucks, Box " Carpet " Factory " Store " Warehouse Try Squares Turning Saw Blades " Saws Twines</p> <p>W</p> <p>Warehouse Trucks Water Buckets Winged Dividers Wire Nails Wooden Clamps Wrenches " Pipe Wringers, Mop</p> <p>Y</p> <p>Yard Sticks</p>
--	--	---	--	--

All of the above are presented in our 55 page Catalogue of Tools and Supplies for Shipping Departments, &c. We would like to send you a copy; if interested, ask for Catalogue No. 1532.

Hammacher, Schlemmer & Co.,

HARDWARE, TOOLS AND SUPPLIES
NEW YORK SINCE 1848

⚡ ⚡ If its Hardware or Tools, and hard to find, try H. S. & Co. ⚡ ⚡
NEW HOME, 4TH AVE. AND 13TH STREET. BLOCK SOUTH OF UNION SQUARE

CANADA LUMBERMAN

AND WOOD-WORKER

WEEKLY EDITION

The Lumberman Monthly Edition, 44 pages} \$1.00 PER YEAR {The Lumberman Weekly Edition, every week.

THIS PAPER REACHES REGULARLY THE PRINCIPAL LUMBER MANUFACTURERS AND DEALERS THROUGHOUT CANADA, AND WHOLESALE BUYERS IN GREAT BRITAIN, THE UNITED STATES, AND OTHER FOREIGN MARKETS.

VOL. XIII.

TORONTO, MONTREAL, WINNIPEG, FEBRUARY 1, 1905

No. 1

CANADA LUMBERMAN

PUBLISHED BY

The G. H. Mortimer Publishing Co. of Toronto, Limited

Confederation Life Building - TORONTO.

Branch Offices:

38 ALLIANCE BUILDING, MONTREAL
720-721 UNION BANK BUILDING, WINNIPEG.
21 GREAT ST. HELEN'S, LONDON, E. C.

The Weekly Lumberman - Published every Wednesday, contains reliable and up-to-date reports of market conditions and tendencies in the principal manufacturing districts and leading domestic and foreign wholesale markets. A weekly medium of information and communication between Canadian timber and lumber manufacturers and exporters and the purchasers of timber products at home and abroad.

The Monthly Lumberman - A 32-page journal, discussing fully and impartially subjects pertinent to the lumber and wood-working industries. Contains interviews with prominent members of the trade, character sketches and portraits of leading lumbermen, etc. Its special articles on technical and mechanical subjects are especially valuable.

WANTED AND FOR SALE

Advertisements will be inserted in this department at the rate of 15 cents per line each insertion. When four or more consecutive insertions are ordered a discount of 25 per cent. will be allowed. This notice shows the width of the line and is set in Nonpareil type; 12 lines make one inch. Advertisements must be received not later than 4 o'clock p. m. on Tuesday to insure insertion in the current week's issue.

EXCELSIOR WOOD WANTED - PEELDED basswood or clear spruce. RANKIN AND CO., Dundas Street, Toronto. Telephone.

FOR SALE - 1", 6 1/4", 2" SOFT ELM. 1", 2", 3", Birch, 1" Wormy Chestnut, 1" 6 1/4", 2", 3", 4" Hard and Soft Maple, 1", 6 1/4", 2" Beech, 1", 2", 3" White Ash, 1", 2", 3", 4" Red and White Oak. Cedar Squares. R. E. KINSMAN, Hamilton.

FOR SALE

Sawmill, capacity 50,000 feet in ten hours, and limits containing over 200,000,000 feet of standing timber. To the person with money this is one of the best propositions in the interior of B.C. For further information address "H.C." CANADA LUMBERMAN, Toronto, Ont.

AT FERNIE, B. C. SAW MILL PLANT AND TIMBER LIMITS

1827 ACRES ONE AND A QUARTER miles from Fernie, B. C. heavily timbered with Cedar, Fir, Spruce and Tamarac, easily accessible for logging purposes both in summer and winter.

Saw Mill Waterous Mill with capacity of 40 thousand feet per day, with planers, lath mill, etc., all complete.

Stables dwelling houses, store, smithy and logging camp all substantially built and ready for occupation.

The limits are held under Crown Grant and purchaser can enter and begin operations without any delay.

For further particulars, price, terms, etc., address

PH. VIBERT, ESQ.,
Manager Union Bank of Canada,
Lethbridge, N. W. T.

or H. B. GILMOUR, ESQ.,
Molson's Bank Building, Vancouver, B.C.

FOR SALE - 60 H.P. HORIZONTAL RETURN Tubular Boiler, good as new, bargain for quick turn-over. Address ALFRED RUBBRA, 22 Victoria Square, Montreal, Que.

WANTED - TEN THOUSAND CORDS Hard and Soft Wood; also same quantity of Slabs. SIMCOE WOOD AND LUMBER CO., 52 Yonge Street Arcade, Toronto.

WANTED - 1" BLACK ASH; ALSO FOR sale, the following: 6,500 6x9-6' 8" Red Oak Ties; 150,000' 2" Dry Indiana White Oak; 50,000' 2" Dry Indiana Red Oak. MCCLURE LUMBER CO., Detroit, Mich.

DRY HEMLOCK LUMBER, CUT LAST season, good sound stock, and will manufacture 60 M ft. 2" plank, 90 M ft. 1 x 8 and 1 x 10 in. stock and 1 in. siding. Price nett, \$12.00 f.o.b. R. R. DRYSDALE, L'Avant Station, Ont.

FOR SALE.

WOULD LIKE PRICES ON SOFT ELM and Soft Maple Lumber. Have from one to three hundred thousand feet, to be sawed this winter. Would be loaded on cars at Petrolia, Ont. Enquire Box 78, Dresden, Ont.

FOR SALE. - SAW MILL MACHINERY, nearly new, capacity 15,000 ft., 100 M feet hardwood logs, 300 M feet hemlock logs, three million feet hemlock and hardwood timber, 1,000 cords bark, 30,000 cords wood complete logging outfit, quantity shingle bolts at mill and in bush. No dues. Close to G.T.R. Good timber locality. Reason for selling, failing health. For price and terms apply to Box 194, CANADA LUMBERMAN, Toronto, Ont.

HARDWOOD LUMBER DEALERS

I CAN BUY FOR YOU AND CUT THIS winter 200 to 400M of Red Oak and Basswood also smaller quantities of other hardwoods. Address "Hardwood," care CANADA LUMBERMAN, Toronto.

FOR SALE.

700,000 ft. dry pine, 1", 2" and 3"; 350,000 ft. dry hemlock, 1" and 2". Also a large quantity of 1st and 2nd class cedar shingles. We will have by spring 75,000 cedar ties and 100,000 cedar posts piled on shore. During the summer we will saw 25,000 cedar ties and a large quantity of cedar timber, boat lumber, etc.

For further particulars apply to McALLISTER BROS., Cockburn Island, Ont.

FOR SALE

Large Tract of Timber

In Central Ontario

THE PROPERTY OF

THE CANADIAN LAND AND IMMIGRATION CO., OF HALIFURTON, (LIMITED).

This company has a large tract of well timbered land about 125 miles northeast of Toronto. There are large quantities of Cedar, Hemlock, Spruce, Balsam, Basswood, Cherry, Birch Maple, also considerable Pine, Elm and Ash on this tract. It is well served by two railroads. The company are prepared to sell this timber in blocks ranging from 2,000 to 10,000 acres or more if desired.

There are several good mill sites on the property. This would be a good opportunity for parties who are at present cut out and looking for a new location.

Maps and plans and further particulars can be had by applying to

W. H. LOCKHART GORDON,
Managing Director,
157 Bay Street, Toronto.

TIMBER FOR SALE.

FOR SALE - BRITISH COLUMBIA'S VALUABLE cedar, fir and spruce timber in selected tracts on the sea coast, within easy reach of Vancouver city. MATHEWS & BREMNER, 417 Hastings street, Vancouver B.C.

WANTED - POSITION AS BAND SAW filer for coming season. Best of references. Saw maker by trade. Box 488, Galt, Ont.

WANTED, 300,000 FEET WINTER CUT Basswood, Common and Better in quality, 1 1/16" thick when dry. Address - Box 189, care of CANADA LUMBERMAN

WANTED. - A SECOND HAND FOR A small planing mill. Apply, stating experience and wages expected, to the MONTREAL COTTON CO., Valleyfield, P.Q.

FOR SALE - 1", 6 1/4", 2" HARD MAPLE, 1" soft elm, 6 1/4", 2" rock elm culls, 1" soft elm culls, 1" basswood culls, 1", 6 1/4", 2" pine, 1" cherry, 1" black and white ash, 6 1/4" white ash, 1" soft maple and 1" birch. Write for prices. THE W. R. THOMPSON CO., Teeswater, Ont.

MICHIGAN HARDWOODS.

FOR SALE - CHOICE DRY ROCK MAPLE, beech, soft elm and basswood, all thicknesses. Low prices. - BROWNLEE & COMPANY, Detroit Michigan.

FOR SALE.

20 HORSE POWER PORTABLE SAW MILL, complete, price \$650.00. Watrous make; also a 40 horse power stationary saw mill, Gagen edger, 3 sawyer; all new machinery three years ago, cost \$2,800.00, will sell for \$1,800.00 in spring, a bargain.

E. TODD,
131 Brant street, Brantford.

FOR SALE.

397,000 feet 2" x 4" and up, Norway Lumber, Log Run.
86,000 feet 1" x 4" and up, Norway Lumber, Log Run.
43,000 feet Mill Culls, etc.
Also the product of two million feet good white pine logs to be cut next summer. Correspondence solicited.

PINE LUMBER COMPANY,
Pine, Ont. (near Cartier.)

For Sale

A FIRST CLASS STAVE AND HOOP MILL, in good state of repair, and with it or not at option of purchaser, the stock of staves and hoops on hand together with a quantity of standing timber. Also horses, harness, trucks, wagons, etc. For all particulars bona fide purchasers may apply to "Staves," in care of CANADA LUMBERMAN, Toronto.

THE LOCATORS. - W. B. Herbert, General Manager, Winnipeg. The largest and oldest exclusive Business Brokers in the West. Address THE LOCATOR, 63 Merchants' Bank Building, Winnipeg.

Lumber and Coal. - In good town on Souris branch about eighty miles from Winnipeg. Stock of seven thousand five thousand cash, or less to a good man, balance easy. Population six hundred, no competition. THE LOCATORS.

Lumber and Machinery. - Five thousand handles, business doing sixty thousand a year, established six years, in growing country, net profit yearly six thousand. THE LOCATORS.

Lumber Business and Buildings. - At a snap, on the Lenore branch hundred and seventy five miles from Winnipeg. Four thousand handles. Enquire at this. THE LOCATORS.

Saw Mill. - One hundred and thirty miles from Calgary. Annual turnover two million. Including blacksmith shop and 3/4 section of land containing five million feet, price six thousand and six hundred, good terms. Apply at once. THE LOCATORS.

We are just getting out our new book of business opportunities and you should write for one. Address THE LOCATORS, Merchants' Bank Building, Winnipeg.

NORWAY PILES FOR SALE. FOR PARTICULARS apply to SIMS LUMBER CO., LIMITED, Sault Ste. Marie, Ont.

WANTED - 1" BLACK ASH 1" CULL BASSWOOD. 6 1/4 Cull Basswood. MCCLURE LUMBER CO., Detroit, Mich.

FOR SALE, 80,000 FT. 1" HARD MAPLE, M.R. 100,000 FT. 1" Birch, M. R. Write Box 192 CANADA LUMBERMAN, Toronto, Ont.

WANTED - ALL PULP MILLS AND PULPWOOD Companies to look up page 7, monthly issue, which is bound to interest you.

WANTED - BY LIVE EXPERIENCED Lumberman stock of lumber to handle on commission. Box 190, CANADA LUMBERMAN.

WANTED - FILER FOR BAND SAWS. Must be reliable. Siate salary expected, etc. Address Box 191, CANADA LUMBERMAN, Toronto, Ont.

WANTED, CONTRACT OF SAWING LATH by the thousand in mill. I guarantee satisfaction and can give reference if required. Address G. R., Box 5, Chemsford Ont.

WANTED - YOUNG MAN WITH KNOWLEDGE of office work and experience in selling lumber, one with knowledge of Ottawa grading preferred. Apply giving references to TIMBER, c/o CANADA LUMBERMAN, Toronto, Ont.

WANTED - AN EXPERIENCED MILLWRIGHT for Band Mill near Quebec. Must be first class man. References required. THE RIVER OUELLE PULP & LUMBER CO., St. Facome, P. Q.

WANTED, A MARKET FOR CUTTINGS from choice hardwood viz: oak, white ash, maple and hickory. Give dimensions. Address P. L. C., care of CANADA LUMBERMAN, Toronto, Ont.

FOR SALE.

LUMBER AND SAW-MILL BUSINESS ON L.C.F.R. Main line. Mill in good running order. Daily sawing 20 to 25 M feet. Timber convenient to mill. Address A.B.C., CANADA LUMBERMAN.

WANTED

Party with timber limits to form Company with a party who has a modern saw mill plant, capacity twenty million, on North Shore Georgian Bay. Address Box 193, CANADA LUMBERMAN, Toronto, Ont.

CURRENT TRADE CONDITIONS.

ONTARIO.

That the lumber market is gradually strengthening is plainly evident. The number of enquiries regarding the new cut which are being received by the manufacturers is very encouraging and an evidence that dealers are disposed to purchase stock. This is further emphasized by one or two important contracts which have recently been closed. Business can be done whenever the manufacturer is willing to accept the prices of the early winter, but in some quarters advances have been made, causing buyers to look around in other directions in the hope of

finding lumber which has not been brought into line with the increase. Nevertheless, those who are asking higher prices believe that there is strong ground for their position and that the developments of the spring will be favorable to the holder of lumber. The report comes from Ottawa that despite the slight decrease in the cost of log production, the Ottawa Valley mill men will hold out for last season's prices. Hardwoods are firmly held and the buying movement shows some improvement. The supply of hardwoods, however, is likely to prove equal to the demand and no important change in price is anticipated in the near future. The developments in the lath market are being watched with considerable interest. A wholesale firm in Western Ontario have been heavy buyers of late and now control a considerable percentage of the available supply. The suggestion of a corner, however, is not considered seriously.

MANITOBA AND BRITISH COLUMBIA.

There is as yet very little activity in lumber circles throughout Western Canada, but many are confident that the present year will witness some recovery from the low prices which have prevailed. There is certain to be a large consumption of lumber, timber and ties in connection with railway extension and improvements undertaken by the Canadian Pacific and Canadian Northern Railway, and while building in Winnipeg may not be as active as during the past year, there is reason to believe that a large quantity of lumber will be required for that purpose. The present low price of lumber should stimulate consumption. The statement has been published that the Mountain Lumber Manufacturers' Association propose to establish retail yards throughout the Northwest, but we shall defer a discussion of this question until more definite information as to the intention of the manufacturers is to hand.

UNITED STATES.

Climatic conditions in the United States have been opposed to any increase in the movement of lumber and nothing more than a normal trade has been done. The demand from the country districts is light, but this is attributed largely to the difficulty of handling lumber at this season of

the year. The demand from this quarter will make itself felt upon the first sign of spring and a heavy trade is anticipated. Inquiry is active and there are no weak spots in the white pine market. The increased stocks in Minnesota are confined chiefly to small mills in the interior and will be consumed without perceptible effect upon prices. Low grade boards have lost none of their recent strength, while the better quality of pine is exhibiting a stronger tone than for some months past. It is stated that mill culls sold in Duluth last week at \$14 and scoots at \$9.25. Spruce is maintaining its strength and some manufacturers have declared their intention of holding their stock at an advance of 50 cents per thousand. Hemlock was never in better position. Among the hardwoods, maple, birch and elm are selling freely, while basswood lags behind both in price and demand.

There has been a sharp advance in lath at Chicago, the current prices being \$4 to \$4.25 for No. 1 white pine and \$3.50 to \$3.75 for No. 1 mixed. Spruce lath have been but little affected by the strength in white pine, as they continue to sell in Boston at \$3.40 for 1 5-8 inch and \$3.15 for 1 1/2 inch.

GREAT BRITAIN.

The year has opened with a much improved outlook for lumber in Great Britain. As we have previously stated, stocks at London and Liverpool are unusually light and the consumption is showing signs of being considerably larger than last year, the shipbuilding and other consuming industries being in a more prosperous condition. There are still some influences against any substantial improvement, but these, it is hoped, will be removed before the importing season has been reached. So far as can be learned, British importers have not yet contracted for their regular supply of Canadian pine and spruce, but we believe they are prepared to admit that more favorable terms could have been obtained in December than at the present time, for the improvement in the United States market has encouraged our manufacturers to hold out for firm prices for British specifications. The present tendency of prices on this side of the water is upward, and if British

importers want our lumber they must be prepared to meet the American competition. It is understood that the railways in Great Britain are likely to consume a considerable quantity of oak this year, and the outlook is favorable for higher prices for that timber.

THE BARBADOS MARKET.

The following report of the Barbados lumber market is furnished by Messrs. S. P. Musson, Son & Company:

"The arrivals of lumber have been as follows: Schooner Laura C, from Liverpool, N. S., with 286,000 ft. white pine, principally second quality; E. A. Post, from Tusket Wedge, N. S., 184,000 ft. white pine, spruce and hemlock; Leah A. Whidden, from Halifax, N. S., 205,000 ft. white pine and hemlock. Of the above the Laura C, failing to obtain an offer, went on to Demerara. The white pine ex E. A. Post was sold at \$25.76 merchantable, \$19.56 second quality and shipping spruce at \$22.26. The cargo of the Leah A. Whidden was sold at \$24.50 merchantable, \$18.50 second quality, and \$19 for hemlock. The Briardene, from Halifax, also had 53,000 ft. spruce and hemlock, for which \$22.08 was obtained for former and \$19 for latter description. Our market is now heavily stocked with white pine, especially second quality, as late cargoes have consisted principally of this, and we were fortunate in placing a cargo to arrive shortly, which was represented as really good, and consisted of 145,000 ft. merchantable and 35,000 ft. second quality, at \$26.00 and \$21.00 respectively. There are reports of other vessels on the way here, and we fear that prices may decline somewhat. Spruce is not in heavy stock, but with cheap white pine in their yards, we expect dealers will not show much anxiety to buy. No arrivals of shingles to note, and it is reported that the schooners Calderwood

and Utility bringing both long and laying cedar have been lost. Stocks of these, however, are ample to meet the demand, which is very slack. Some sawn Cypress ex. Adonis, which we reported in our last as having being imported for a dealer, were evidently rejected, as consigners offered them for sale, and accepted \$3.25 for 4 x 18, and \$4.50 for 6 x 18 and 6 x 24."

J. B. Farwell & Son

.. CONTRACTORS AND DEALERS IN ..

Canadian Cedar Telegraph, Telephone and Electric Light Poles

Orillia, Ont., and Oswego, N.Y.

ADVERTISE YOUR WANTS IN

Weekly Canada Lumberman

Toronto Montreal Winnipeg

The Cook & Bros. Lumber Co.

Of Ontario, Limited
MILLS at SPRAGGE, Algoma Dist., Ont.
on "Soo" Branch C.P.R.

OFFICES { Manning Arcade, Toronto
Coristine Building, Montreal
And at Mills at Spragge.

MANUFACTURERS OF

White and Red Pine Lumber and Lath

Water Shipments

WOODS & SPICER, Limited

.....MANUFACTURERS OF.....

BRITISH COLUMBIA RED CEDAR SHINGLES

Capacity 100 Million a Year.

We have had over 15 Years Experience, and are not Asking our Competitors for any Pointers as to Quality.

Wire Your Orders at **OUR EXPENSE** to Agents, or to us at **VANCOUVER, B. C.**

KNIGHT BROTHERS CO.
Burk's Falls, Ont.

KILN-DRIED BIRCH FLOORING

Send for Catalogue
* * * Samples by Mail

KNIGHT BROTHERS CO.
Burk's Falls.

Keenan Bros., Limited

Owen Sound, Ont.

HARDWOOD, HEMLOCK AND PINE LUMBER

We carry a full supply of native Hardwoods always on hand and solicit your inquiries. At the present time we have piled at outside points about 2,000,000 feet of Hardwoods, and about the same quantity of Hardwood, Hemlock and Pine piled here in Owen Sound, and we should be able to interest you if in the market.

WILL MAKE SPECIAL PRICES ON
BROKEN LOTS AT OUTSIDE POINT

ORILLIA PLANING MILL

Near G.T.R. Station

PLANING, MOULDINGS, MATCHING,
FLOORING, RESAWING, SIDING

Done any quantity. Write for price.

S. POMEROY, Phone
311

MASON, GORDON & CO.

WHOLESALE TIMBER

Montreal, Quebec

Eastern Agents The B. C. Mills, Timber & Trading
Co., Vancouver, B. C.

DOUGLAS FIR Timber in any size or length supplied
WRITE FOR PARTICULARS AND QUOTATIONS.

EVERYTHING IN LUMBER AND TIMBER

DRESSED AND IN THE ROUGH

BULMER, McLENNAN & COMPANY

MONTREAL, QUE.

Office and Yard, 571 DORCHESTER ST.

P. O. BOX 116

BROOM HANDLES.

If an enterprising man with supplies of cheap Spruce, Basswood or Poplar care to put in several machines to work broom handles we can take his output. Write in first instance to Empire, care of CANADA LUMBERMAN.

HARDWOOD PRICES AND STOCKS.

The annual meeting of the Hardwood Manufacturers' Association of the United States was held at Nashville, Tenn., on Tuesday, January 24th, at which an official price list was adopted. The prices fixed are given in part below:

SOFT ELM.—1 in. log run, \$20; 1 1/4 to 2 in., \$20.

SOFT MAPLE.—1 in. log run, \$18; 1 1/4 to 2 in., \$20.

ASH.—No. 1 and 2, 1 in.; \$40; 1 1/4 to 2 in., \$43.50; 2 1/2 in., \$53; 3 in., \$55; 4 in., \$58. No. 1 common, 1 in. \$27.50; 1 1/4 to 2 in., \$29.50; 2 1/2 in., \$35; 3 in., \$37; 4 in., \$40. No. 2 common, 1 in., \$18; 1 1/4 to 2 in., \$20; 2 1/2 to 4 in., \$22.

PLAIN WHITE OAK.—No. 1 and 2, 1 in., \$42.50; 1 1/4 and 1 1/2 in., \$44.50; 2 in., \$45.50; 2 1/2 in. \$50; 3 in., \$55; 4 in. \$60. No. 1 Common, 1 in., \$30; 1 1/4 and 1 1/2 in., \$32; 2 in., \$33; 2 1/2 in., \$38; 3 in., \$40; 4 in., \$45. No. 2 Common, 1 in., \$18; 1 1/2 and 1 3/4, \$20; 2 in. \$22; 2 1/2 in., \$23; 3 in., \$24; 4 in., \$25. No. 3 Common, 1 in., \$15; 1 1/4 and 1 1/2 in., \$16; 2 in., \$18. Plain red oak to be same price as plain white oak.

QUARTERED WHITE OAK.—No. 1 and 2, 3/8 in., 6 to 9 in., \$40; 1 1/2 in., \$47; 3/8 in., \$55; 5/8 in. 12 in. and up, \$85; 3/4 in. 6 to 9 in., \$62.50; 1 in., 6 to 9 in., \$70; 1 in., 10 and 11 in., \$85; 1 in. 12 to 14 in., \$110; 1 in. 15 in. and up, \$160; 1 1/4 to 2 in., \$73; 2 1/2 in., \$80; 3 in., \$85; 4 in., \$90. No. 1 Common 3/8 in., 6 to 9 in., \$25; 1/2 in., \$30; 5/8 in., \$35; 3/4 in. 6 to 9 in., \$40; 1 in., \$45; 1 1/4 to 2 in., \$48.

The statistics compiled by the secretary showed stocks on hand January 1, 1905, of 436,261,000 feet, as compared with 359,322,000 feet on July 1, 1904. It may be explained, however, that a larger number of mills reported at this meeting and that the comparative statement of those who reported July 1, 1904, shows a decrease in the amount of stocks on hand of 30,000,000 feet, or 12 1/2 per cent. The following table shows the quantity of each kind of lumber on hand:

crease in the amount of stocks on hand of 30,000,000 feet, or 12 1/2 per cent. The following table shows the quantity of each kind of lumber on hand:

	July 1, 1904	Jan. 1, 1905
Ash.....	6,985,000	7,728,000
Basswood.....	24,292,000	19,748,000
Beech.....	2,204,000	4,262,000
Birch.....	13,832,000	10,883,000
Butternut.....	238,000	257,000
Cherry.....	542,000	1,665,000
Chestnut.....	10,265,000	14,871,000
Cottonwood.....	24,220,000	33,320,000
Cypress.....	10,126,000	7,682,000
Rock Elm.....	3,394,000	1,930,000
Soft Elm.....	7,258,000	9,410,000
Gum.....	34,984,000	43,853,000
Hickory.....	1,263,000	1,619,000
Soft Maple.....	1,395,000	2,730,000
Hard Maple.....	22,003,000	34,029,000
Plain White Oak.....	24,915,000	48,315,000
Plain Red Oak.....	16,649,000	19,598,000
Qtd. White Oak.....	17,016,000	37,148,000
Qtd. Red Oak.....	3,220,000	7,047,000
Poplar, Rough.....	115,066,000	115,553,000
Poplar, Worked.....	15,794,000	6,156,000
Pecan.....	47,000	60,000
Sycamore.....	899,000	3,984,000
Walnut.....	2,715,000	4,413,000
Totals.....	359,322,000	436,261,000

L. Dean Holden, Pres. J. M. Diver, Gen'l.-Mgr. A.F. Holden, Vice-Pres. E. C. Barre, Ass't Mgr.

The Cleveland-Sarnia Saw Mills Co., Limited.

Manufacturers and Wholesale Dealers in

Timber, Lumber, Lath and White Pine Shingles

Special Bills Cut to Order in White Pine, Norway and Fir, any length from 10' to 60' long.

—SARNIA, ONT.

M. & L. Samuel, Benjamin & Co.
503 Temple Building, Toronto.

EXPORT DEPARTMENT.

Correspondence solicited with exporters of wooden goods, such as Sanitary Woodware, Broom Handles, Fork and Shovel Handles, Turned Goods, etc. Payments made on receipt of Bill of Lading at Toronto. European House, SAMUEL SOUS & BENJAMIN, 16 Philpot Lane, London, Eng.

THE KING AND BARTLES LUMBER CO.
PINE, POPLAR AND HARDWOODS

HEADQUARTERS HARDWOOD
Citizens' Building, Distributing Yard
Cleveland, O. McMinnville, Tenn.
We buy and sell Pine in Car and Cargo Lots

ROBERT WATT
WIARTON, ONT.

Manufacturer and Dealer in

Hard and Soft Wood Lumber, Lath, Shingles, Cedar Posts and Ties.

SPECIAL: About 70 M feet of 1" Basswood, One car load of 3x4 Hardwood Hearts suitable for Car Stakes, One car each of 3" and 4x4 Cedar. Prices upon application

C. S. POWELL & CO.
Lumber Exporters

604 Temple Bldg., TORONTO
and at NEW ORLEANS, LA.

To Millmen Cash buyers all kinds hardwoods We solicit correspondence. . . .

THE IMPERIAL LUMBER CO., LIMITED
SAW AND PLANING MILLS, WARREN, ONT.
RED AND WHITE PINE DEALS
All kinds of **SAWN LUMBER** By Carload or Cargo.
Registered Cable Address: "Pinewood" American Lumberman Telecode.
BRANCH OFFICE, MANCHESTER, ENG.
Head Office, TORONTO, CAN.

SAGINAW LUMBER & SALT CO.
MANUFACTURERS OF
LUMBER AND SALT
Mills at Sandwich, Ont.
R. H. ROYS, Pres.
RALPH LOVELAND, Vice-Pres.
C. A. KENT, Sec'y.
R. S. ABBOTT, Treas.
SAGINAW, MICH.

AT MIDLAND

100,000 feet 1 x 4 and 5 Mill Run
150,000 feet 1 x 6

Write for Prices, also for my 1905 CALENDAR. Both Good.



J. D. SINCLAIR FOR **High Grade Cedar**
Vancouver Cedar Mills
VANGOUVER B.C.

THE MENZ LUMBER COMPANY
Manufacturers and Wholesalers
BRITISH COLUMBIA FIR, SPRUCE AND CEDAR LUMBER, RED CEDAR SHINGLES

We Solicit Your Inquiries. **J. F. FOSS, Manager.** 624-625 Union Bank, Winnipeg, Man.

CEDAR LUMBER AND POLES FOR SALE

I can saw out to your order, during the winter months, bills in heavy square Cedar, or Planks. Have also for sale a few cars of Poles from 25 to 50 ft. Correspondence Solicited.

J. S. FINDLAY, OWEN SOUND, ONT.

J. D. SHIER LUMBER CO., LIMITED
BRACEBRIDGE, ONT.
MANUFACTURERS OF
LUMBER, LATH AND SHINGLES
Pine, Hardwood and Hemlock Floorings and Ceilings. Sash and Doors, Wood Turnings etc. All Dressed Lumber Kiln Dried if desired End Matched Flooring a Specialty.
GOOD PINE SIDINGS A SPECIALTY

Planing, Matching, Resawing, etc. In Car Lots.
Manufacturer of Doors, Sash, Mouldings, Ceilings End-Matched and Bored **HARDWOOD FLOORING** A SPECIALTY.
Lumber Kiln Dried in Any Quantity.
J. R. EATON - Orillia, Ont.
Correspondence Solicited. Phone No. 54.

THE CHARLEMAGNE & LAC OUVAREAU LUMBER CO., LIMITED
404 Coristine Building, MONTREAL, P. Q.
Mills at Charlemagne and Montcalm on Great Northern Railway.

SAWN AND DRESSED **LUMBER**
Clapboards, Shingles, Laths, Butter Boxes
Write us for quotations. Shipments by rail or water.

CACHE BAY LUMBER INDUSTRIES.
Geo. Gordon & Co.,
Manufacturers of RED and WHITE PINE
Band - Gang **LUMBER**
Circular **L AND LATH**
CACHE BAY, Ont. C. P. R. 26 miles West North Bay

CACHE BAY PLANING MILL CO.
... MANUFACTURERS OF ...
CROSS ARMS MOULDINGS
CROSS ARMS CEILING
FLOORING
WAINSCOTING
SHEETING
Lumber of Dressed and Pine Lumber.

Cedar Cove Mill,
Vancouver, B.C.

E. H. HEAPS & CO.,

Ruskin Mill
Ruskin, B. C.

Vancouver, B. C.

Lumber, Lath, Shingles, Doors, Mouldings, Etc.

SPECIALTIES :

AA1 HIGH GRADE CEDAR SHINGLES.

Cedar Bevelled Siding, Cedar Door and Sash Stock, cut to size, Cedar Finish, Base, Casing, Newels
Balusters, etc. Douglas Fir Timber up to 85 feet in length.

W. J. SHEPPARD, PRESIDENT
Waubushene, Ont.

J. G. SCOTT, GENERAL MANAGER
Vancouver, B.C.

Pacific Coast Lumber Co.

LIMITED

VANGOUVER, B.C.

MANUFACTURERS OF

Fir, Cedar and Spruce Lumber, Lath, Mouldings, Turned Work, Etc.
High Grade Red Cedar Shingles

Ontario Representative, W. J. LOVERING,

112 Mail Building, TORONTO

D. C. CAMERON, President and Manager.

WM. ROBERTSON, Secretary.

J. E. YOUNG, Cashier.

The Rat Portage Lumber Co., Ltd.

Manufacturers
of

White and Red Pine Lumber, Lath, Shingles, Sash,
Doors, Turned and Band Saw Work

Dealers in CEDAR POSTS, POLES and TAMARAC PILING

Mills at RAT PORTAGE and RAINY RIVER, Ontario, WINNIPEG, Manitoba, and VANCOUVER, British Columbia, Head Office: RAT PORTAGE, Ontario

Our Vancouver Mill cuts High-Grade Cedar, Fir, Spruce and Red Cedar Shingles. Winnipeg Mills cut Pine, Tamarac and Spruce Lumber
We also Manufacture all kinds of Mouldings, Sash, Doors, Turned Work and Boxes. Correspondence solicited at all four points.

THOS. KIRKPATRICK,

MANUFACTURER OF

 **Red Cedar Shingles**

Daily Capacity,
250,000

Mills at Hastings and New Westminster

Head Office: Hastings, B.C.

Orders Solicited and Correspondence Promptly Attended to. Telephone B 1425
Ontario Representative: W. J. SMITH, Fergus.

Export Lumber & Shingle Co.

Wholesale Dealers

Limited

British Columbia Lumber and Shingles

The management of this company have had a lengthy experience in manufacturing and selling British Columbia Lumber and Shingles in Canada and the United States, and are well informed as to the requirements of the trade in those sections.

We are in a position to make prompt shipments at current market prices.

Correspondence and inquiries for prices and other information regarding British Columbia lumber conditions promptly answered.

YOUR TRADE RESPECTFULLY SOLICITED

VANCOUVER - BRITISH COLUMBIA

COOKE & TAIT

MANUFACTURERS OF ALL KINDS OF

B. C. FIR AND CEDAR LUMBER AND SHINGLES

Saw Mill, Planing Mill and Shingle Mill: False Creek, Vancouver, B.C.

WRITE FOR PRICES.

Hazelmere Lumber Co.

HAZELMERE, B. C.

MANUFACTURERS OF

FIR, CEDAR and SPRUCE LUMBER

CLEAR CEDAR AND FLOORING

Our Specialty.

Long Distance Telephone.

W. C. WELLS

PALLISER, B. C.

Manufacturer of

High Grade Spruce, Fir, Cedar and Lumber of all Descriptions.

CORRESPONDENCE SOLICITED.

CANADIAN MANUFACTURERS and WHOLESALERS

THE PEMBROKE LUMBER CO.

PEMBROKE, ONT.

We have just completed a new list of all our Pine and Spruce Lumber and Dimension Timber, and will be pleased to send you a copy on application. **SOLICITING YOUR ORDERS.**

DELAPLANTE - McBURNEY LUMBER CO.,

WHOLESALE

White Pine, Hemlock, Lath, Shingles

Stocks in Ontario at { Collingwood Midland Powassan Whitney Cartier Sturgeon Falls Callander North Bay

Office, Yards and Docks, **NORTH TONAWANDA, N. Y.** Send us your enquiries

FOR Pine, Hemlock, or Hardwood, Lumber and Timber, Telegraph Poles, Ties, Posts, Lath, Shingles, Dressed Lumber, Sash, Doors, Interior Finish, End Matched and Bored Hardwood Flooring, etc., try

JOHN HARRISON & SONS COMPANY, LIMITED

We have a complete stock, two Saw Mills running in summer and one all winter. **HEAD OFFICE, SAW AND PLANING MILLS, OWEN SOUND, ONT.**

RHODES, CURRY & CO., Limited

LUMBER MERCHANTS.

Yards at Amherst, Little Forks, Sydney and Halifax.

BUILDING MATERIAL of all kinds carried in stock. We are buyers of Ontario Basswood, Elm and Pine.

Amherst, N.S.

Sawn and Hewn Spruce, Hemlock, Pine and Birch Timber, Spruce and Pine Boards and Plank, Birch and Ash Boards and Plank, Flooring, Shingles, etc.

JAMES J. MURPHY, Bank of Hochelaga Building QUEBEC

Is it your wish . . .

To Purchase or Sell as quickly as possible
A PARTICULAR LOT OF LUMBER
A MILL PROPERTY
SECOND-HAND MACHINERY



an Advertisement in the "Wanted" And "For Sale" Department of the **CANADA LUMBERMAN WEEKLY EDITION** Will secure for you a Buyer or Seller, as the case may be. Address. **The Canada Lumberman, Toronto**

THE M. BRENNEN & SONS MANUFACTURING CO., LIMITED

Saw Mills at **RAINY LAKE, Ontario.** Planing Mill and Head Office: **HAMILTON, Ontario.**

THE NIPISSING LUMBER COMPANY, LIMITED

Mills at **CACHE BAY and SPANISH RIVER, Ontario.**

Manufacturers of and Wholesale Dealers in all kinds of **LUMBER AND LATH**

Both Railway Delivery and Water Shipments. Correspondence Solicited. **The NIPISSING LUMBER CO., Limited** Head Office: **HAMILTON, ONT.**

AUGER & SON - Quebec PULP WOOD AND TIES

Bought at Any Station.

Also Dimension Timber, Sawn to Sizes, Telegraph Poles and Lumber.—Write Us.

A. F. BURY AUSTIN WHOLESALE LUMBER and TIMBER CANADA PINE

Bank of Ottawa Building, 224 St' James St., - **MONTREAL, CANADA**

SPECIALTIES: Railway Ties, Timber and all kinds of Hardwoods; Ship Decking, Norway and White Pine, Dimension Timber, Norway Car Sills, Car Flooring, Telegraph Poles, Railway Ties, Oak and Whitewood, Planed and Rough Lumber, British Columbia Pine, Southern Pine, &c.; Birch Flooring, hollow back, end butted.

Sole Eastern Agent for The North Pacific Lumber Company, Limited, Barnet, B. C.

Douglas Fir: Timber in any size or length up to 90 feet long. Timber Planers face up to 24 inch x 30 inch. Kilns of large capacity. Rough and Dressed Lumber, Douglas Fir and Cedar.

WRITE FOR PARTICULARS AND QUOTATIONS.

R. LAIDLAW LUMBER CO.

18 Toronto Street, Toronto

JAS. PLAYFAIR.

D. L. WHITE.

PLAYFAIR & WHITE

Manufacturers and Wholesale Dealers

LUMBER • LATH • SHINGLES

Contractors for Railway Supplies **BILL TIMBER** a Specialty

MIDLAND, ONT

A. & P. WHITE

Manufacturers of and Dealers in

Sawn and Planed Lumber, Dimension Timber, Joisting Car Sills, Car Flooring, Shingles and Lath.

PEMBROKE ONT.

F. MCGIBBON & SONS,

PENETANGUISHENE ONT.

Manufacturers of Pine, Hemlock and Hardwood Lumber, and dealers in Cordwood Hemlock Bills cut on short notice.

MAITLAND, RIXON & CO. OWEN SOUND, ONTARIO.

Manufacturers and Dealers

LUMBER, LATH, TIES, POLES, SHINGLES, ETC.

Make a Specialty of Long Pine, Cedar and Hemlock Bill Stuff. We ship by C. P. R., G. T. R., and by Water.

Turner Lumber Co., Limited

MANUFACTURERS

LUMBER and LATH

Shipments by Rail or Water. **Midland, Ont.**

D. D. FLANNER

H. W. REEVES

FLANNER & REEVES

Manufacturers and Wholesalers of

WHITE AND NORWAY PINE LUMBER

LATH AND SHINGLES

CAR AND CARGO MIDLAND, ONTARIO

HARDWOOD FLOORING

End Matched, Bored, Steel Polished, and Bundled

Send for Price List

A few cars of selected Maple and Birch and other Hardwoods at close price

THE SEAMAN KENT CO., Limited

60 Bay St., Toronto

Factory, Meaford, Ont.

ROBT. STEWART LIMITED

GUELPH, ONTARIO

MANUFACTURERS OF

Doors, Sash, Mouldings,

Stairs, Hardwood Flooring, Etc.

Canadian and American Hard and Soft Woods of all descriptions

SPECIALTIES

YELLOW PINE AND OAK TIMBER

Sole Canadian Representative of the

SOUTHERN CYPRESS LUMBER SELLING COMPANY

New Orleans, La.

NEW BRUNSWICK LETTER.

(Correspondence of the CANADA LUMBERMAN.)

ST. JOHN, N.B., January 31st, 1905.—The lack of life in all branches of the lumber industry is still the predominant feature as regards this part of the country. The coming season is attracting the attention of the local lumbermen to a much greater extent than the small transactions of the present month.

The stocks of English deals on the local wharves are decreasing slowly but surely. Several shipments, ranging in quantity from 25 to 125 standards, have gone forward since January 1st by the liners which make this port their winter terminus. The sum-total of all holdings of English at this port would range from 7,500,000 sup. feet to 8,500,000 feet, the latter figure being the outside estimate. The much greater part, in fact practically all, of this quantity has been secured and is now held by local commission houses. It is probable that the bulk will not be put upon the market before the end of three months, and not then if the indications apparent at that time warrant the holding of it still longer.

As far as can be learned (and this quoting the best local authorities), the volume of business in the English market is so small that the prevalent prices could

scarcely be named as general nor yet as indicative of what figures will prevail a month hence. But it is conceded on all sides that at the present moment all conditions tend to an improvement with the resumption of trade; the dealers on the other side of the water are carrying small stocks, the prospects point to an excellent business in the building line and shippers seem to be in no haste to put their goods upon the market.

In the United States the prospect for New Brunswick spruce deals seems particularly good. Here, too, stocks are very light and arrivals few and the indications point to a boom in building.

For boards and scantling the outlook in this direction is not so bright. Last season business in these lines was very dull, the demand being at all times small when the supply is considered. At this stage there is no sign of improvement that could be called unmistakable. While the receipts from New Brunswick of this line of goods in the United States market have been very light during the last four months, prices have not rallied nor is it considered that there is any prospect of their doing so in the immediate future.

The price of spruce lath continues to fluctuate. Since last writing there has been an improvement of 25 cents per M.

New Brunswick product lath are now quoted at \$2.10 and American at \$2.35 per M. f.o.b. St. John.

BRITISH COLUMBIA LETTER.

(Correspondence of the CANADA LUMBERMAN.)

VANCOUVER, B. C., January 23rd, 1905.—Prices of logs are very firm and an advance is looked for within the next month or two. It means that the corner attempted by Mr. J. S. Emerson has been successful. Several months ago when depression existed in the logging industry, Mr. Emerson quietly went to work and bought up as much of the available supply as was possible. The mills were closing down because of slow demand, and to make the usual repairs, and having logs on hand they did not augment their supply. Lately some of the mills have started again, and spring orders are beginning to come in, with the result that logs are wanted. The price goes as high as \$7.50 at present, and will probably continue at top-notch figures until nearly June. It is expected there will be an increase of about \$1 during the next 30 or 60 days, and another rise after that. Then the price will be the highest ever known in British Columbia.

There will be considerable disappointment if no duty is placed on lumber entering Canada from the United States, for in

anticipation of this action of the Dominion Government, all the mills are preparing for a big cut during the coming summer. Particularly in the interior, large amounts of logs are being taken out, and the millmen there confidently hope that the limited Canadian market will be reserved for Canadians. Settlers in the Territories will get their lumber cheaper this year than ever before. The move anticipated a couple of months ago of the whole of the lumber manufacturers of this province withdrawing from the Western Retail Lumber Dealers' Association, has been taken, and the western mills will establish depot yards in the Territories. Thus lumber will be sold to the consumer direct, and the profit of the middleman will be saved. If no duty is placed on lumber, there is no use denying that conditions will be serious. "If the Government does not grant protection, it may not be improbable that there will be a price war," a well known lumberman said, "for the retailers will be supplied by American mills, and the lumber manufacturers of Canada will have their own yards. Every effort, though, will be made to stave this off."

Mr. John Hendry, president of the B.C. Mills, Timber & Trading Company, will leave to-day for Ottawa, in connection

UNITED STATES MANUFACTURERS AND WHOLESALERS

YOU
CAN
REACH

**THE BONSAK LUMBER CO.
WHOLESALE HARDWOODS**

ST. LOUIS
BY
RAIL, MAIL
WIRE OR
'PHONE

CHARLOTTE HÄBERLE

Wholesale and Retail Dealer in

YELLOW PINE and OAK TIMBER

Large stock of Timbers and Bill Stuff carried in stock.
All sizes and lengths for immediate delivery.

Telephone No. 10 - - Cedar Street, NIAGARA FALLS, N.Y.

MCGLURE LUMBER CO.

Wholesale Dealers in . . .

Hardwood Lumber

Carry in Stock and Have for Sale

ASH, BASSWOOD, BEECH, BIRCH, BUTTERNUT, CHERRY, CHESTNUT, COTTONWOOD, CYPRESS, ELM, GUM, HICKORY, MAHOGANY, MAPLE, OAK, POPAR, SYCAMORE, WALNUT, POLES (Oak, Hickory and Ash), RIMS and SPOKES (Oak and Hickory), OAK BENDING PLANK, OAK BILL STUFF, RAILWAY TIES.

Office and Yards: 520 to 530 Franklin St., DETROIT, MICH.

Correspondence Invited on All Hardwoods.

H. D. WIGGIN BOSTON, MASS.
89 STATE ST.

will inspect at mill and PAY CASH for

LOG RUN

Elm, Ash, Bass and other Hardwood

CORRESPONDENCE SOLICITED.

YELLOW PINE

We are in position to give first - class stock. Reasonable prices. Prompt shipments. Mills in Alabama Mississippi and Arkansas.

MANN, WATSON & CO. Muskegon, Mich.

ACME LUMBER CO.

Grand Rapids, Mich., U.S.A.

Wholesale Hardwoods

Hard Maple and Rock Elm our Specialty.

We invite correspondence whether you wish to buy or sell.

ONE DOLLAR

Will pay your subscription to the CANADA

LUMBERMAN for

ONE YEAR

WANTED 5/8 Inch Quartered Canadian Spruce
and Thick Birch

J. F. QUIGLEY LUMBER CO.

94 Pearl Street

Grand Rapids, Mich.

THE ROBERT H. JENKS LUMBER CO.

CLEVELAND, OHIO

MANUFACTURERS AND WHOLESALERS OF

YELLOW PINE, POPLAR, HEMLOCK AND HARDWOODS

Yellow Pine Timbers a Specialty

Indiana Lumber & Veneer Co.

INDIANAPOLIS, IND.

Sawed and Sliced Quartered
Oak a Specialty

Correspondence Solicited. ~~~~~

Veneers

FRANK C. BURY

BURY & NOBLE

MASON A. NOBLE

WHOLESALE

LUMBER - DETROIT

MICHIGAN

Send us your inquiries for Southern Yellow Pine.

with the duty matter, and will join the large deputation which will meet the Government on February 7th. Mr. Hendry is president of the B. C. Lumber & Shingle Manufacturers' Association, and also vice-president for British Columbia of the Canadian Manufacturers' Association, and will confer with the officials of the latter organization in Toronto before proceeding to Ottawa.

Japanese are buying up small shingle and lumber mills in this vicinity and also on Puget Sound, preparing for the demand which is expected to follow the development of the Orient after the war.

The British ship Nelson and the Ameri-

can schooner Wilbert L. Smith are loading lumber at the Hastings mill, the former for Europe, and the latter for Osaka, Japan.

CANADIAN LUMBER SHIPMENTS.

From St. John, N.B.: Steamer Montcalm, for Montreal and Bristol, 1,046 bds. pulp board, 104,656 ft. deals, 1,113 ft. ends, 75,178 ft. birch deals, 99 ft. birch scantling, 24,288 ft. ends, 2,171 doors, 1,478 bds. maple flooring. Steamer Parisian, for Liverpool, 71,498 ft. deals, 170 ft. scantling, 167 ft. ends, 28,288 ft. birch plank, 1,321 ft. birch ends. Steamer Mount Temple, for London and Antwerp,

133,595 ft. deals, 9,000 bds. shooks, 2,506 doors, 24,534 pcs. lumber. Ship Savonia, for Buenos Ayres, 716,177 ft. scantling, 469,026 ft. boards. Steamer Montrose, for London and Antwerp, 240,118 ft. deals, 3,373 ft. ends, 27,000 bds. shooks.

From Halifax, N.S.: Steamer Parisian, for Liverpool, 104,888 ft. hardwood lumber, value \$1,214, 109,907 ft. hemlock deals, value \$1,200, by S. Cunard & Co., agents. Steamer Dahome, for St. Vincent, B.W.I., 19,344 ft. spruce boards, value \$268; for Demerara, 13,000 ft. pine boards, value \$200, by Pickford & Black, agents.

From Bear River, N.S.: Barquentine Ethel Clarke, for Buenos Ayres, lumber.

Barque Carrie L. Smith, for Buenos Ayres, lumber. Schooner Joseph L. Hay, for West Indies, lumber.

From Digby, N.S.: Barque Vanadis, for Buenos Ayres, lumber.

Cable address: "Dundonian, Dundee."

BERG & SON,

Timber and Wood Pulp Agents and Brokers

DUNDEE, SCOTLAND

Contracts made between Shippers and Importers
Correspondence solicited

BRITISH WOOD BROKERS AND IMPORTERS

FARNWORTH & JARDINE

Wood Brokers and Measurers

Cable Address "Farnworth," Liverpool, 2 Dale St., 71 Regent Road **BOOTLE LIVERPOOL, ENG.**

F. A. Lightbody & Co.

8 Gordon Street - GLASGOW, SCOTLAND

WOOD BROKERS

Cable Address: "TENEBRIS," GLASGOW. Codes: A. B. C., A 1, "Zebra" and Private.

Agents for **CANADIAN WHITE PINE AND SPRUCE; Hardwoods in Log, Etc.**
Shipments handled to the best advantage to all ports in the United Kingdom. Correspondence Solicited.

LOUIS BAMBERGER, 2 Broad Street Building, LONDON, E. C.

IMPORTER OF ———— Telegraphic Address "Bellywood, London."

Pine, Spruce and all Canadian Wood Goods

Are Open to Contract for Glued-Up **BASSWOOD KEYBOARDS**

ZEBRA CODE A. B. C. CODE DIRECTORY CODE

GELLIBRAND, HEYWOOD & CO.

Wood Agents and Brokers

Cable Address: "GELLICHT," LONDON 57 Gracechurch St. London, E.C. England

SMITH & TYRER - 14 Tithebarn Street, LIVERPOOL

.. **WOOD AGENTS** ..

Cable Address—"Walmer," Liverpool.

Halifax, N.S., Office—SMITH, TYRER & Co., Metropole Bldg., Hollis St. Halifax, N.S.

Edmiston & Mitchells

TIMBER BROKERS

Cable Address: "EDMISTON" Glasgow.

33 Renfield Street, GLASGOW

GANT & KEMP  **TIMBER BROKERS**

52 St. Enoch Square, GLASGOW

Cable Address: "TECTONA" Glasgow.
A1 and A B C Codes used.

Every lumberman wants it **35 cents buys it**

Scribner's Lumber and Log Book

BRIMFUL OF EVERY-DAY PRACTICAL INFORMATION

Address: THE CANADA LUMBERMAN Toronto

CABLES, DOORCHECK, LONDON

We are Buyers of Pine Doors and Mouldings, Electric Wire Casings, W.C. Seats, Wooden Mantel Pieces, Sashes and Frames, and all kinds of ready made joinery.

LONDON STORES: Locke's Wharf, Edmonton, N.

STAVERS & STAVERS

OFFICES: 158, Leadenhall Street, London, E.C.

Manufacturers and Importers of JOINERY

FELBER, JUCKER & CO.

Lumber Importers

MANCHESTER ENGLAND

Invite offers from Lumbermen for . . .

Spruce Deals and Battens, Spruce and Pin Floorings, Shooks, Sashes, Mouldings, Dowels Broom Handles, Chair Stock, Seats, etc., or any Woods Suitable for English Market.

Telegraphic Address: FELBER MANCHESTER.

ASHTON & PETFORD

BISHOP LANE, - HULL, ENGLAND

BUYERS OF BOX SHOOKS

Invite correspondence from manufacturers who are in a position to export to Great Britain.

Cable address, "Shooks," Hull.
Codes—A. B. C. 4th Edition and Zebra.

JOSEPH OWEN & SONS, LTD.

Timber Importers

Cable Address "Owen Liverpool" Liverpool, Eng.

We are in the Market for

Black Walnut Logs and Boards, Pine Deals and Siding
White Ash Planks, best quality, in long lengths
Oak Planks, best quality, in long lengths
Rock Maple Logs and Planks, White Oak Logs
All classes of Manufactured Wood Goods
Rock Elm Logs, waney Birch Logs

Send full particulars of what you have to offer, with prices.

JAMES WEBSTER & BROTHER

BOOTLE, LIVERPOOL, ENGLAND

TIMBER MERCHANTS

BUYERS OF Oak, Birch, Ash, Grey Elm Logs and Lumber, Elm Staves and Heading, Handles of all description
Venours a Specialty

ALFRED DOBELL & COMPANY
WOOD AGENTS AND BROKERS

Liverpool and London Chambers - LIVERPOOL, ENGLAND

CABLE ADDRESS "DOBLE LIVERPOOL"

THOMPSON, BLOIS & KJELGREN ———— **ALL KINDS OF LUMBER AND LOGS**

CASH ADVANCES MADE AGAINST SHIPPING DOCUMENTS . . .

BRANCH OFFICES
41 Corporation St., MANCHESTER
Waterloo Chambers, GLASGOW

HEAD OFFICE
17 Gracechurch St., LONDON, E.C.

BRANCH OFFICE
Brook 1, HAMBURG

THE ONTARIO LUMBER CO. LIMITED

Mills: North Bay. C.P.R. and G.T.R. Delivery.

MANUFACTURERS WHITE PINE LUMBER, LATH AND SHINGLES.

35 and 36 Home Life Building TORONTO, Ont. MILLS: French River, Georgian Bay Water Shipment Only.

GEO. G. GLADMAN MANUFACTURER OF WHITE PINE AND HEMLOCK LUMBER LATH AND SHINGLES

Mills at Smith's Bay Township of Carling

PARRY SOUND, ONT.

CORRESPONDENCE SOLICITED

WILLIAMSON & MORRISON LUMBER WHOLESALE

Mills at L'Original, Ont.

HEAD OFFICE: 30 St. John Street, MONTREAL, P.Q.

JAS. LUNNY & CO., HINTONBURG, ONT.

Have for Sale ASH, ELM, BASSWOOD, PINE, SPRUCE AND HEMLOCK IN QUANTITIES

Eastern Agents--B. C. Shingles and Douglas Fir, all dimensions Can dress to 24x30. B. C. Cedar Write for quotations

ONE DOLLAR

Will pay your Subscription to the Weekly and Monthly CANADA LUMBERMAN for

ONE YEAR

THE WOODSTOCK LUMBER & MANUFACTURING CO., Wo dstock, Ontario. Manufacturers of and Wholesale Dealers in Pine, Hemlock & Hardwood Lumber ENQUIRIES PROMPTLY ATTENDED TO.

A. P. EBERT

MANUFACTURER OF AND DEALER IN Pine and Hardwood Lumber, Lath, Shingles, Posts, Broom Handles, and Short Hardwood Dimension Stock WARTON, ONT.



THE NEW LINE

Through the Spruce Forests of the Laurentian Mountains--between Quebec and Hawkesbury. WATER-POWERS, TIMBER LIMITS AND ELECTRIC POWER FOR SALE. IDEAL PULP-MILL SITES. Unexcelled Export Facilities at Quebec. A. J. GORRIE, General Supt. MONTREAL GUY TOMBS G. F. & P. A.

CURRENT LUMBER PRICES--WHOLESALE

TORONTO, ONT.

CAR OR CARGO LOTS.

Table listing lumber prices for various types like 1 inch No. 1 Pine, 1 1/2 inch No. 1 Pine, etc.

HARDWOODS--PER 1. FEET CAR LOTS.

Quality, 1s and 2s unless otherwise specified.

Table listing hardwood prices for species like Elm, rock, mill, Hickory, etc.

QUEBEC, QUE.

WHITE PINE--IN THE RAFT

Table listing white pine prices in raft for different measurements.

RED PINE--IN THE RAFT.

Table listing red pine prices in raft.

OAK--MICHIGAN AND OHIO.

Table listing oak prices from Michigan and Ohio.

ELM.

Table listing elm prices.

ASH.

Table listing ash prices.

BIRCH.

Table listing birch prices for various sizes.

OTTAWA, ONT.

MANUFACTURERS' PRICES.

Table listing manufacturer prices for pine goods and slidings.

Table listing lumber prices for Pine good strips, Pine shorts, Pine, good shorts, etc.

BAY CITY AND SAGINAW, MICH.

UPPER AND SELECTS.

Table listing lumber prices for Upper and Selects, including Uppers, Selects, and Fine Common.

STRIPS, A AND B (CLEAR AND SELECTS).

Table listing strip prices for different widths and lengths.

FINE COMMON OR C

Table listing fine common or c prices.

SELECTED NO. 1 SHELVING OR FENCING STRIPS.

Table listing selected no. 1 shelving or fencing strips.

BARN BOARDS OR STOCKS.

Table listing barn board or stock prices.

SHIPPING CULLS OR BOX.

Table listing shipping culls or box prices.

SHAKY CLEAR.

Table listing shaky clear prices.

SHINGLES, 18-IN.

Table listing shingle prices for 18-inch sizes.

LATH.

Table listing lath prices for No. 1 White Pine and Hemlock.

ALBANY, N.Y.

PINE.

Table listing pine prices for Albany, N.Y.

LATH.

Table listing lath prices for Albany, N.Y.

SHINGLES.

Table listing shingle prices for Albany, N.Y.

Table listing lumber prices for LATH and SHINGLES.

BUFFALO AND TONAWANDA, N.Y.

WHITE PINE.

(Wholesale selling price.)

Table listing lumber prices for Buffalo and Tonawanda, N.Y., including Uppers, Selects, and Fine Common.

The following quotations on hardwoods represent the jobber's buying price at Buffalo and Tonawanda:

Table listing hardwood prices for Buffalo and Tonawanda, including White Ash, Black and Brown Ash, Birch, Elm, and Maple.

BOSTON MASS.

Table listing lumber prices for Boston, Massachusetts, including White Pine Uppers, Selects, and various types of shingles.

NEW BRUNSWICK CEDAR SHINGLES.

Table listing New Brunswick cedar shingle prices.

BRITISH COLUMBIA SHINGLES.

Table listing British Columbia shingle prices.

THE CHILLIWACK SHINGLE MANUFACTURING COMPANY.

No more pretty sight on the continent could gratify the eye of the lover of fair scenery than the site occupied by the mill of the above company at Harrison River, B.C. As seen from our illustration, it stands on a river, the Harrison river, just above its confluence with the great and mighty Fraser. The scenery around is not only interesting but matchless, the great river flowing between vertical walls of black rock, while towering away in the distance are the snow-clad peaks of the mighty Sierras.



MILL OF THE CHILLIWACK SHINGLE MANUFACTURING COMPANY, CHILLIWACK, B. C.

The site occupied covers twenty-one acres, the main building of the mill being 80 feet long by 60 feet broad. It possesses an equipment of four Dunbar machines, one shingle block power feed and various hand machines. The boiler house, separated a few feet away, is equipped with 100 horse power capacity in boilers and 60 horse power in engines.

There are two dry kilns, 120 x 34 feet, shipping sheds and warehouses and over 400 feet of siding along the main line of the Canadian Pacific Railway.

The company are the owners of over 10,000

plating erecting a large saw mill and going into the manufacture of clear cedar, confident that with such a product to offer the consumer success cannot but await them in the undertaking.

The mill has been running since 1898, formerly under the name of Fulbrook & Innes. Three years ago it was burned down, the new company being organized to rebuild the present mill arising on the old site.

Both the president, Mr. L. Neville Smith, and the secretary and treasurer, Mr. A. Neville Smith, are successful men in the trade

and highly respected citizens of the small but rising town of Chilliwack near by.

THE EMPIRE LUMBER COMPANY.

The above company's property, consisting of a saw, planing and lath mill, is beautifully situated right in the centre of the rising divisional town of Revelstoke. Close by flows the mighty Columbia, just a mile or so below, passing the property of the Revelstoke

on Arrow Lake, from the Harbor Lumber Company, which just one year before had bought the property from the Fred Robinson Lumber Company.

The mill is equipped with all the machinery and specialties of a first-class plant, the machinery being supplied by M. Garland & Company, of Bay City, Michigan. The planing mill is equipped with five planers, siding resaw and rip saw, while a long chain transfer carries the lumber from the saw mill to the planers.

An unusual feature in the working of the mill is seen in the use of a cable conveyor for carrying the refuse 540 feet from the mill to the fire dump. The manager of the mill states that he finds it superior to the chain conveyor, as it requires less power and is not so often in need of repairs. Two boilers 72" x 18' of 140 H. P., and two engines of 250 H. P., supply the driving power, while an electric motor and engine furnish light to the mill. The capacity is 50,000 feet a day, all of this being shipped via the C. P. R. to the Territories and Manitoba.

The mill at Comaplix is almost an exact duplicate of the one at Revelstoke except that the planing mill is run by water power and all the slabs and refuse are carried away by sluice boxes and used in building piling grounds on the shores of Arrow Lake. It has a capacity of 60,000 feet per day, all being marketed in the Northwest.

As the mill stands away from the railway, the company have built six car barges, 34 x 125 feet, to carry the lumber to Arrowhead. These barges are drawn by their own tug boat. They also run a freight and passenger boat from Arrowhead into Comaplix and Beaton, making two trips a day.

Both Mr. C. H. Johnson, the manager, and Mr. R. S. Butler, are Americans hailing from Minnesota.

FURNITURE CITY KNIFE GRINDER.

"It was just what somebody wanted," is the only apology that the Furniture City Tool Company, of Grand Rapids, Mich., has to offer for the existence of



SAMPLE OF BRITISH COLUMBIA CEDAR.

acres of some of the finest cedar in the province just a few miles away from the mill, along the shores of Harrison Lake. With such a magnificent asset to draw upon, and the fact that they put the entire output into shingles, coupled with the possession of all the auxiliary equipment and machinery necessary for the manufacture of a first-class shingle, one can readily understand how it is that the product, 100,000 per day of ten hours, is marketed all through the Territories, Manitoba and eastern points. So excellent, indeed, is their cedar that the company are seriously contem-

Lumber Company, while all around are the snow clad peaks of the Selkirk mountains. It is from Revelstoke during the summer months that the C. P. R. attach an observation car specially designed to allow unbroken view of the wonderful mountain scenery.

The company was organized on March 16th, 1904, purchasing the mill at Revelstoke and one at Comaplix, seven miles from Arrowhead

their popular knife grinder, which is shown herewith.

They claim no original idea in its construction, and limit its practical use to the grinding of machine knives by the factory man who is willing to use ordinary good judgment, and wishes to keep his knives in good order at a nominal cost. As may be seen by the illustration, the machine is built very substantially, and all parts are adjustable to meet necessary demands. Parties interested are invited by the CANADA LUMBERMAN to write the manufacturers for information about this machine.



KNIFE GRINDER MADE BY THE FURNITURE CITY TOOL COMPANY, GRAND RAPIDS, MICH.

FOR THE CAMP

We have a very suitable lot of goods for camp supplies. We make this kind of trade a specialty. You who are not getting suited just as well as you would like, try us for your next order, and give us a chance to demonstrate our ability to give you satisfaction in this very important department of your business.

H. P. ECKARDT & CO.

Wholesale Grocers

TORONTO

THE HANCHETT BAND SWAGE SHAPER.

Expert saw filers are coming more and more to use the swage shaper or pressure side file for side dressing purposes. This is especially true of band resaws, until now a swage shaper is considered indispensable for fitting them. The side dressing of band resaw and gang saws has much to do with the successful cutting of good, straight smooth lumber. The Hanchett band swage shaper is claimed to complete the work of the saw swage and press every tooth to a perfect shape—widest on the face, widest at the extreme points, thus making a perfect clearance. This is accomplished by a pair of hardened tool steel dies, one upon each side of the tooth, which presses it to any desired gauge. The dies are accurately ground and bevelled in two ways so as to taper the saw tooth downward from the point, and backward from the face. The dies are set in plugs which are forced together by a screw running through them having a right hand thread on one end and a left hand thread on the other end.

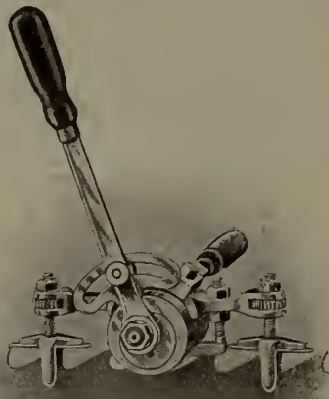

BAND SWAGE SHAPER MANUFACTURED BY THE GORDON HOLLOW BLAST GRATE CO.

The dies may be easily removed from the plugs by a punch and reground at any time by the filer.

The swage shaper makes every tooth exactly alike, hence every tooth must do the same amount of work. This suggests an easy running saw, smoother and better lumber and requiring less power.

The Hanchett band swage shaper is an efficient pressure side dresser and is noted for its great speed and ease of operation, the excellent work which it does, simplicity of construction, perfect adjustment and its durability. These swage shapers are made of the best material it is possible to procure. The head is made from a solid piece of steel, hence no slipping and loosening of bolts and nuts. It is bored accurately to accommodate the easy working of the plugs, which are also made of a fine grade of steel. The dies and tooth stop are made of the best grade of tool steel and are carefully tempered. The levers and other parts are made of malleable iron and steel and are nicely polished and nickel plated. They are compact, solid, and strong. They are not complicated; while they have all necessary attachments they have no unnecessary ones. The

slotted circle with which the dies are attached to the shaping lever is a very handy arrangement. The operator can adjust the shaping lever to whatever position is the most convenient for him, or if he wishes to change the spreading of the dies he may do so even to a hair's breadth without changing the position of the lever. The arms to which the forks are attached keeps the shaper from tipping upward or backward, while the forks keep the shaper in line on the saw, and are adjusted easily and perfectly by the knurled nuts. The shaping is done by one lever, the other handle being put on merely for convenience in operating. Perhaps the most distinctive feature of the whole machine is the tooth guide or stop. This little device keeps the teeth from striking on the side of the shaper or the dies as they pass by. The adjustment is measured from the point of the tooth, hence it makes each tooth exactly the same shape no matter what the irregularity of spacing, pitch, etc.

The Hanchett swage shapers will dress from 60 to 75 teeth per minute as commonly used by filers. It would pay all those interested in such a tool to write to the manufacturers, The Hanchett Swage Works, Big Rapids, Michigan, U.S.A. They are always glad to send their tools out on approval.

TRADE NOTES.

The Conners-Woods Machinery Company has been formed at Sarnia, Ont., to manufacture self feeders, portable saw mills, etc. G. F. Conners is president of the company, which is capitalized at \$40,000.

The Toronto office of Messrs. E. C. Atkins & Company, saw manufacturers, Indianapolis, Ind., has been removed from 30 Front Street East to 56 King Street East, where Mr. C. D. Ten Eyck, the local manager, will be pleased to meet his friends and saw users generally.

The Marine Iron Works, of Chicago, are now building a very fine steel vessel for quick passenger service on Northern Lake Michigan. It will have a finely modelled steel hull 142 feet long by 28 feet beam and will draw with ordinary load 11 feet.

The Ontario Government has recently granted incorporation to the Stratford Mill Building Company, Limited, of Stratford, Ont., to manufacture boilers, mill machinery, etc. The directors include William Preston and James B. Greig, and the capital stock is \$200,000.

The Canadian Corundum Wheel Company, Limited, of Hamilton, Ont., has been incorporated, to manufacture corundum and emery wheels and emery wheel grinding machines. The share capital is placed at \$40,000, and the directors are Levi Sherk, H. E. Sherk, George F. Webb, William Bell and A. S. Devine.

The business of Shurly & Dietrich, saw manufacturers, Galt, Ont., is steadily expanding. They now propose to give more attention to woodworking and for that purpose have built an addition to their works. This will enable them to extend their output materially and increase their export trade, which has become quite an important factor in their business.

The foundry business carried on by McFarlane, Thompson & Anderson at Fredericton, N. B., has been converted into a joint stock company, under the name

of The McFarlane, Thompson & Anderson Manufacturing Company, Limited. The capital stock is \$75,000. The incorporators are Walter McFarlane, of Nashwaakasis, and Hon. F. P. Thompson, Willard Kitchen, Charles A. Miles and Alexander Thompson, of Fredericton.

The Canadian Casualty & Boiler Insurance Company, of Toronto, have made another addition to their already competent and experienced staff of engineers. The new appointment is that of Mr. Charles Granberg, who is regarded in engineering and insurance circles as one of the best in his class. We learn that this company have had a successful year and the constant increase of their business necessitates the selection of the best engineers. This appointment is along the right line for an aggressive company whose reliability depends on the excellence and thoroughness of their inspectors.

CALENDARS RECEIVED.

Since our January issue went to press calendars have been received from C. A. Larkin, wholesale lumber dealer, Toronto; J. C. McLaren Belting Company, Montreal; M. Brennan & Sons, lumber manufacturers, Hamilton; Auger & Son, lumber, pulp wood and ties, Quebec, and the Standard Hardwood Lumber Company, Buffalo.

—The McClure Lumber Company, wholesale hardwood lumber, Detroit, Mich., have increased their capital stock from \$40,000 to \$150,000 and have elected the following officers and directors: President, W. G. Vinton; vice-president and general manager, A. V. McClure; treasurer, C. J. Vinton; secretary, G. I. McClure; director, C. F. McClure.



Corrugated Iron

*For Sidings, Roofings,
Ceilings, Etc.*

Absolutely free from defects—made from very finest sheets.
Each sheet is accurately squared, and the corrugations pressed one at a time—not rolled—giving an exact fit without waste.
Any desired size or gauge—galvanized or painted—straight or curved.
Send us your specifications.

The Metallic Roofing Co.
WHOLESALE MANAGERS, LIMITED
TORONTO, CANADA.

WANT EXPORT OF LOGS PROHIBITED.

At a meeting of the paper and wood pulp manufacturers of Canada held in Montreal last month, it was unanimously resolved that in the interests of the Dominion and especially of the province of Quebec, every effort should be made to enact legislation to prohibit the export of logs and pulp wood. A special committee was appointed for the purpose of preparing a petition to lay before Parliament, now in session at Ottawa.

The following companies were represented at the meeting: James MacLaren Company, Chicoutimi Pulp Company, Laurentide Paper Company, E. B. Eddy Company, Jonquires Pulp Company, Lake Megantic Pulp Company, Canada Paper Company, Chatham Pulp and Paper Company, Montmagny Pulp Company, J. R. Booth, Ouatichouan Falls Pulp Company, Jacques Cartier Pulp and Paper Company, Jos. Ford & Co., Price-Porritt Pulp and Paper Company, Belgo Pulp and Paper Company, Northern Mills Company, Rolland Paper Company, St. Raymond Pulp and Paper Company.

QUEBEC PULP WOOD SHIPPERS.

Mr. A. J. Auger, of the well-known lumber firm of Auger & Son, Quebec, is said to be the pioneer exporter of pulp wood from that district. In 1885 he received the first order from the Dominion Pulp and Paper Company, of Providence, R.I. To-day very large quantities of pulp wood are shipped to the United States,

the firm of Auger & Son alone last year exporting wood to the value of \$126,000. The price of pulp wood twenty years ago was about \$1.50 per cord, but it now worth \$6. Two years ago the firm above mentioned purchased 40,000 cords of pulp wood from the farmers in the Arthabaska district, for which they paid \$224,367.42, an average of \$5.25 per cord. This firm was also the first to deal in poplar wood from which is manufactured soda pulp.

Mr. B. A. Scott, of Roberval, is also largely interested in the cutting of pulp wood for export to the United States. Last year he cut 5,000 cords of rossed wood, and this year will cut in the neighborhood of 15,000 cords.

PULP NOTES.

John Cameron, master mechanic for the Royal Paper Mills Company, East Angus, Que., was instantly killed on January 10th by being caught in the machinery.

Sir Alfred Harmsworth is the head of the Anglo-Newfoundland Development Company, recently incorporated at St. John's, Nfld., with a capital of \$5,000,000, to manufacture pulp and paper.

A suit has been commenced at St. John, N.B., that may bring about a sale of the Cushing's Sulphite Pulp Company's mill at that place, the solicitors for the Eastern Trust Company, which represents the bond holders, having brought suit to foreclose the mortgage.

The Department of Customs at Ottawa has been advised that it is the intention of the United States to impose countervailing duties upon all wood pulp imported from the Province of Quebec pending the decision of the appeal which has been made to the United States Board of General Appraisers. The duty is to be imposed upon all wood pulp, whether manufactured from wood cut upon Crown lands or upon private lands.

The officials of the Consolidated Lake Superior Company, Sault Ste Marie, Ont., report that by contract the entire output of the pulp mills for 1905 will be disposed of in the United States. It is stated that in making shipments to England some dissatisfaction arose in connection with the tests. The advance in the price of pulp in the United States market will mean considerably increased earnings for the Soo mills.

Letters patent, dated January 4th, 1905, have been issued incorporating the Miramichi Pulp & Paper Company, Limited, to acquire and operate the pulp mill at Chatham, N.B., formerly owned by the Maritime Sulphite Fibre Company. The capital stock of the new company is placed at \$300,000, and the incorporators include George T. Keyes, of East Peperell, Mass., C. A. Hight, of Boston, and James Beveridge, of St. John, N. B. It is understood that Mr. Beveridge has been appointed manager.

The announcement comes from Vancouver, B. C., that the Pacific Coast Power Company and the Industrial Power and Pulp Company have amalgamated, and that \$3,500,000 worth of stock has been underwritten in England to float the proposition. Both companies have secured a reserve from the British Columbia Government of 80,000 acres of timber lands, so that their total holdings will be 160,000 acres. It is stated that steps are to be taken at once to build very large pulp and paper mills.

Mr. E. Huard has resigned his position as mill superintendent for the Rainy River Lumber Company, Rainy River, Ont., and has returned to Minneapolis.

C. H. VOGEL

A. M. Can. Soc. C. E.
OTTAWA, CAN. ENGINEER
Surveys, Plans, Specifications and Supervision
WATER POWER
Paper, Pulp and Sulphite Fibre Mills

Allis-Chalmers-Bullock, Limited, Montreal

SAW MILL MACHINERY

Band and Circular Saw Mills, Carriages, Set Works and Appurtenances, Conveying and Transferring Machinery, Trimmers, Slashers and Cutting Off Saws, Edgers, Lath Mills and Bolters, Adjustable Arbor Boxes, Filing Room Tools, Timber Preserving Plants. ❧ ❧ ❧ ❧

ALSO MAKERS IN CANADA OF . . . BULLOCK ELECTRICAL MOTORS AND GENERATORS

Head Office and Works : MONTREAL

Branches : HALIFAX, N. S. TORONTO, ONT. WINNIPEG, MAN. ROSSLAND and VANCOUVER, B. C.

THE NEWS

ONTARIO.

—J. Cowley has built a new saw mill at Lavallee, Ont.

—John Smith has sold his planing mill at Tilsonburg, Ont., to West & Jackson.

—Joseph Millard is advertising his planing mill and furniture business at Newmarket, Ont., for sale.

—The Seaman-Kent Company, of Meaford, Ont., are installing a new dry kiln of 75,000 feet capacity.

—Reinke & Boland, owners of the Dominion Planing Mills, Eganville, Ont., intend increasing their capacity.

—Disenroth & Eydt have purchased the planing mill and lumber yard of Weiderhold & Honderich at Milverton, Ont.

—W. C. Crawford, of Tilbury, Ont., has purchased the mill site of H. Sloan at that place and intends building a saw, planing and heading mill.

—The explosion of a boiler in the saw mill of George Whitehead at Cultus, near Woodstock, Ont., killed four men and completely wrecked the building.

—The firm of McDonald & Watson, lumber manufacturers, Huntsville, Ont., has been dissolved. The business will be continued by J. A. McDonald.

—The Ross-Taylor Company, of Exeter, Ont., have installed in their planing mill a thirty-eight horse power engine made by the Robert Bell Company, of Seaforth.

—The mill of the Rathbun Company at Deseronto, Ont., cut 17,000,000 feet of lumber last year. The millwrights in charge were James Baird and Thomas Hart.

—The by-law to assist the Carney Lumber Company to build a saw mill at Owen Sound, Ont., was sanctioned by the ratepayers on January 2nd, and the work will be proceeded with as rapidly as possible.

—The Pigeon River Lumber Company have cut a large number of logs this winter on their Gunflint limits, which are being transported to Port Arthur over the Duluth extension of the Canadian Northern Railway.

—The Muskoka Lakes Milling & Supply Company, of Toronto, has been incorporated, to buy timber and manufacture lumber and wooden articles. The directors are A. E. Henderson, A. Ogden, A. D. Watson and R. I. Henderson, of Toronto, and A. A. Young, of Rosseau.

—The Wilberforce Lumber Company, of Durham, Ont., has been incorporated during the past month, with a capital of \$40,000. The company will manufacture lumber, railroad ties, shingles, lath, etc. The provisional directors are George Sparling, A. S. Hunter and David Jamieson.

—The Consumers' Box & Lumber Company, Limited, of Toronto, has been incorporated, with a capital of \$100,000. Authority is given to carry on a box making, saw mill, planing mill and general lumber business.

The promoters are J. B. Miller, John McClelland, Frank Sully and W. B. Tindall, all of Toronto.

THE EASTERN PROVINCES.

—A. J. Slater intends installing a shingle machine in his mill at Kirkland, N.B.

—Laurent Breault and Cleo. Breault will conduct a lumber business at Marston, Que., under the name of C. Breault & Cie.

—O. H. Scroder, Montreal, and D. M. Campbell, of Westmount, have formed a partnership as lumber dealers at Kiskissink, Portneuf County, Que., under the firm name of Campbell & Skroder.

—Aime M. Dechene and Alfred M. Dechene, land proprietors and timber limit owners, have entered into partnership at St. Roch des Aulnais, Que., under the name of A. M. Dechene & Company.

—A Dominion charter has been granted to the Alza Company, of Montreal, to manufacture window sashes, window screens and doors. The promoters are Joseph S. Teasdale, Henry L. O'Donoghue and Joseph C. Moore.

—William Currie & Company, whose woodworking factory at Campbellton, N. B., was destroyed by fire last month, decided not to rebuild and have sold their mill site to J. & D. A. Harquail, who have a woodworking establishment at that place.

—The annual meeting of the Fredericton Boom Company was held at St. John, N. B., on January 10th, when the following officers and directors were elected: President, A. H. F. Randolph; secretary, C. L. Jewett; managing committee, W. H. Murray, A. H. Randolph, Parker Glasier and E. L. Jewett.

—John E. Moore & Company is the title of a new lumber firm at St. John, N.B. The members are John E. Moore, J. Wilson, jr., and W. White, all of St. John, and H. W. Lightburn, of Liverpool, Eng. Connection has been established by the new company with Alfred Dobell & Company, who will handle the shipments made by the firm to England.

—The annual meeting of the Newfoundland Timber Estates was held recently in Montreal. The chief business was the ratifying of the sale of their Millerton property in Newfoundland to the Harmsworths of London. It was reported that cutting on the properties of the company is being extensively carried on this winter, the estimated output being 40,000,000 feet.

—The Inglewood Pulp Company, who purchased Knight Bros.' timber limits in St. John, Queens, Kings and Charlotte Counties, N.B., are conducting extensive operations this winter, this being necessary on account of a large portion of their limits being swept by fire during the summer of 1903. When the pulp market improves, the company will take out pulp wood as well as saw logs.

—The Campbell Lumber Company, who recently purchased the property of the Sissiboo Pulp & Paper Company at Weymouth, N.S., have about two hundred men at work in the woods this winter and expect to

take out about 7,000,000 feet of logs. They have also built a tramway for carrying the lumber from the mill to the wharf. They are manufacturing large quantities of boxes, which are being shipped to New York, Boston and Cuba.

MANITOBA AND THE TERRITORIES.

—C. Hubert has purchased DeFehr's lumber business at Didsbury, N.W.T.

—The Alberta Sash & Door Company has been incorporated at Calgary, N.W.T.

—W. H. Mills has purchased the lumber business of A. Bricker, Okotoks, N.W.T.

—S. Swoboda has withdrawn from the Rosenroll Lumber Company, Wetaskiwin, N.W.T.

—Robert F. Steele, lumber dealer, Treherne, Man., has sold his business to Thomas S. Bear.

—Hugh A. Rose has bought H. Sampson's interests in the Brandon Brick & Lumber Company, of Brandon, Man.

—The Saskatchewan Wood Manufacturers Company, Limited, has been incorporated by the Northwest Government.

—The business of George Smiley, lumber and implement dealer, Manor, N.W.T., will hereafter be carried on by E. and J. J. Smiley.

—R. J. Noble has sold his lumber business at Oxbow, N.W.T., to the Robertson Adams Lumber Company, of Crystal City, Man.

—MacKay, Cockrane & Company, lumber and implement dealers, Plum Coulee, Man., have sold their lumber business to J. C. Graham.

—The Royal Lumber & Fuel Company, recently organized in Winnipeg, have secured a site on Notre Dame ave. west, and will establish a first class plant.

—A new firm at Brandon, Man., is McDiarmid & Clark, who intend establishing a planing mill. The machinery, we understand, will be driven by electric power.

—D. R. Fraser & Company, who operate a large saw mill at Edmonton, N.W.T., propose to construct dams and other improvements on the Saskatchewan river above Edmonton to facilitate the floating of saw logs to their mill.

—The Red Deer Lumber Company kept open house in their offices, 306-313 Union Bank Building, Winnipeg, during the recent meeting of the Western Retail Lumbermen's Association, when they met many of their old friends and made many new ones.

BRITISH COLUMBIA.

—The British Columbia Government has granted incorporation to the Violin Lake Lumber Company, Limited, with a capital of \$50,000.

—M. McInnes, of Cranbrook, B.C., in conjunction with eastern capitalists, is building a saw mill at Elkmouth, B.C., with a capacity of 30,000 feet per day. He has a timber limit of 8,000 acres.

CRAIG MINE CRYSTAL CORUNDUM WHEELS

Our Pure Crystal Corundum Saw Gummars have no equal for their Rapid, Cool, Cutting Properties.



Read the following from Bulletin 180 of the United States Geological Survey, which says:

"Often a distinction is made between emery and corundum, many persons not recognizing emery as a variety of corundum.

Emery is a mechanical admixture of corundum and magnetite or hematite. It is, of course, the presence of corundum in the emery that gives to it its abrasive qualities and makes it of commercial value, and the abrasive efficiency of emeries varies according to the percentage of corundum they contain."

Emery is imported, mined by Greeks and Turks and contains only about 25% corundum. Our Crystal Corundum is guaranteed to be 98% pure alumina, a Canadian product, mined and manufactured by Canadians for Canadians.

HART CORUNDUM WHEEL COMPANY, Limited, Hamilton, Ont., Can.

—The Mundy Lumber Company are making good progress with the erection of their saw mill at Three Valley Lake, near Cranbrook, B.C.

—Moore & Whittington, contractors, have made application to the Dominion Government for water front privileges at Victoria, B.C., their intention being to build a saw mill with a capacity of 20,000 feet per day.

—R. J. McNab has purchased the saw mill of the Thompson River Lumber Company at Kamloops, B.C. It is understood that the property was acquired on behalf of a new company, which will have a capital of \$10,000.

—H. A. Wilson, of Stillwater, Minn., was in Vancouver, B. C., recently, with a view to completing arrangements for the erection of a large saw mill. He is said to represent capitalists who are prepared to invest \$400,000.

The Everett Timber & Investment Company has been registered in British Columbia as an extra-provincial company. The head office of the company is situated at Everett, Wash., and their attorney is E. V. Bodwell, 34½ Government street, Victoria.

—The Fraser River Saw Mills, Limited, has been incorporated by the British Columbia Government, with a capital of \$500,000. The purpose is to carry into effect an agreement between E. J. Dodge, of Alameda, California, and Lester W. David, of New Westminster, B.C., and to carry on the business of saw millers.

—The coming year promises to witness considerable activity in lumbering operations around New Westminster, B.C. The old Ross-McLaren mills, which have been standing idle for about fifteen years, will shortly be opened by the Fraser River Saw Mills Company, of which Lester W. David is president. Associated with him will be E. J. Dodge, of San Francisco, first vice-president; W. P. Fowle, of Bellingham, second vice-president; Ernest Walker, of New Westminster, secretary, and George A. Innes, of San Francisco, treasurer. New machinery will be installed in the mill. It is understood that all the output will be exported and no attention given to local trade. An entirely new mill will also be started in New Westminster by the Small & Bucklin Company, who are planning to build on the Fraser river.

VARIABLE FEED TRIMMER.

The Gordon Hollow Blast Grate Company, the largest manufacturers of hollow blast grates, edgers and trimmers in the world, have added to their line the "Tower" variable feed one-man 2-saw trimmer, which we herewith illustrate. This trimmer is designed for mills cutting up to 50,000 feet in ten hours. It is iron and steel throughout, and the only trimmer on the market with a variable feed. The manner of adjusting the saws saves time, steps and lumber.

In order to show the working parts of the trimmer as clearly as possible, the illustration represents the middle headblock as transparent. This headblock is, of course, stationary, and is intended only to keep the lumber from sagging.

The shifting crank is detachable. It will be noticed

that it fits on a shaft the end of which is square. In the illustration this crank is shown as hanging straight downward. This was done for the sake of showing the parts more clearly. In actual operation, however, the crank occupies a horizontal position; although being detachable, it can be made to hang down, if desired. The leading advantages of the "Tower" variable feed one man 2-saw trimmer may be summed up as follows:

1. First and foremost is the variable feed. The feed can be adjusted anywhere between a minimum of 20 feet per minute for thick lumber and a maximum of 50 feet for thin lumber. It can be started, changed or stopped while the saws remain in motion.

2. The crank for shifting the saws is carried by one of the transfer blocks, instead of being at one end of the machine as is customary. This construction (i. e., the one employed by the Gordon Hollow Blast Grate Company) is claimed to have two distinct advantages over the ordinary arrangement. They are: (a) There is a great saving of time and labor, especially with short boards. With other trimmers it is necessary to go to

standard, adjusting nuts being provided for this purpose. Thus, while as sent out from the factory the machine trims one inch plump, as 16' 1", 18' 1", etc., the adjustment may be changed so that it will regularly cut 16' 2" or 16' 3", or 18' 2", or 18' 3", etc.

The saws travel in unison, in opposite directions. A complete revolution of the shifting crank increases or decreases the distance between the saws exactly 2 feet half a revolution 1 foot, and a quarter of a revolution 6 inches.

Unless otherwise specified, these trimmers are provided with saws 22" in diameter x 10 gauge. If desired, saws of any size up to and including 24" in diameter may be substituted.

Those interested would do well to write to the Gordon Hollow Blast Grate Company, Greenville, Michigan, for Catalogue D.

PERSONAL.

Mr. William G. Clarke, of Clarke Bros., lumber manufacturers, Bear River, N.S., has been elected

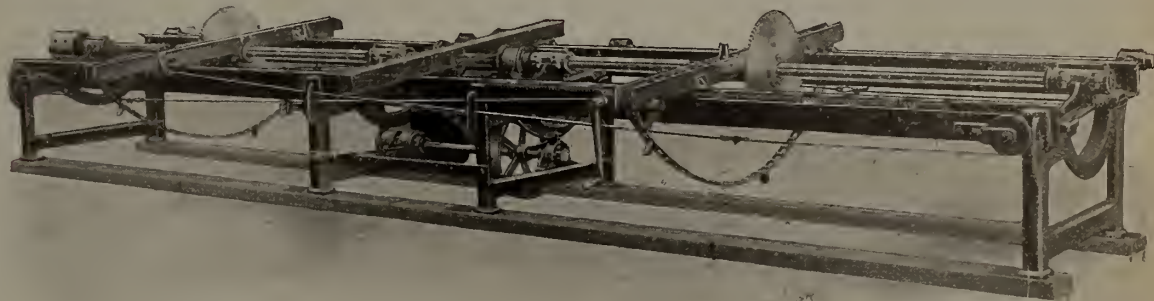

VARIABLE FEED TRIMMER MANUFACTURED BY THE GORDON HOLLOW BLAST GRATE COMPANY.

the end of the machine every time the saws are shifted. With this one it is never necessary to go beyond the end of the board. The result is a great saving in the number of steps taken, and an increase in the quantity of work done. (b) With this machine, the operator, travelling as he does with one of the transfer blocks, is in a position to see instantly how to trim a board to the best advantage, which he could not do from the end of the trimmer. This often means a saving of lumber by reducing weight.

3. The Tower variable feed one-man 2-saw trimmer is provided with the best of facilities for removing the saws, which may be done by simply removing the two stud bolts and the support for the arbor at the end of the trimmer. See illustration.

4. The transfer blocks are connected by rods and steel rope, as there is no "give" to them, which is not true of a link belt, or of any other medium. There are two similar sets of these connections, one in front and the other in the rear.

5. The transfer blocks may be quickly regulated at any time so as to cut an inch or two longer than the

Warden of the municipality of Annapolis for the present year.

Mr. Dan Wilson has been elected Mayor of Collingwood, Ont., for another year. His opponent was Mr. B. Patton.

Mr. Ralph Loveland, of the firm of Loveland & Stone, Cutler, Ont., was a visitor to Toronto during the past month.

Mr. Thomas Pitts, of Detroit, senior partner of the lumber firm of Pitts & Charlton, spent a week in Toronto last month.

Mr. William Power, M.P., of the wholesale lumber firm of W. & J. Sharples, Quebec, has been elected president of the Board of Trade of that city.

Mr. D. S. Deschamps, of the lumber firm of Blue & Deschamps, Rossland, B.C., has joined the ranks of the benedicts, having taken as a life partner Miss DeGagne, of Trail, B.C.

Mr. J. F. Birchard has severed his connection with J. T. Wing & Company, of Detroit, and is now on the road for J. L. Tallman & Sons, manufacturers of bab-bitt metals and solders, Hamilton, Ont.

The Hanchett Adjustable Saw Swage

For large and small Circulars, Bands, Band Resaw, and Gang Saws.

FILERS MILLMEN

A TRIAL WILL COST YOU NOTHING. We send you these tools for you to use for 30 days, free. If you then feel that you can afford to do without them you are to return them at our expense. They save Time—Files—Labor—Saws. Adjustments are perfect. Construction simple. Workmanship the best. They have stood the test. You run no risk when you purchase a Hanchett Saw Swage. They are standard make.

Write for circular to—

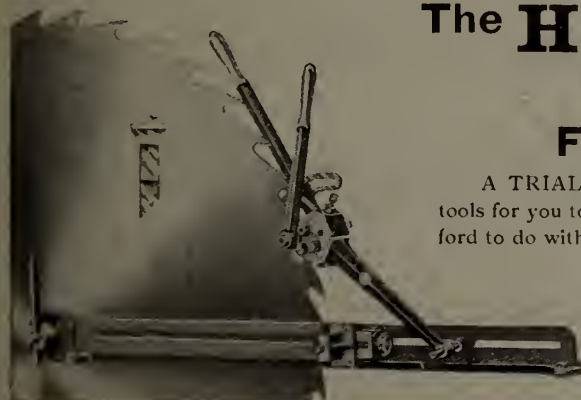

Hanchett Band Saw Swage

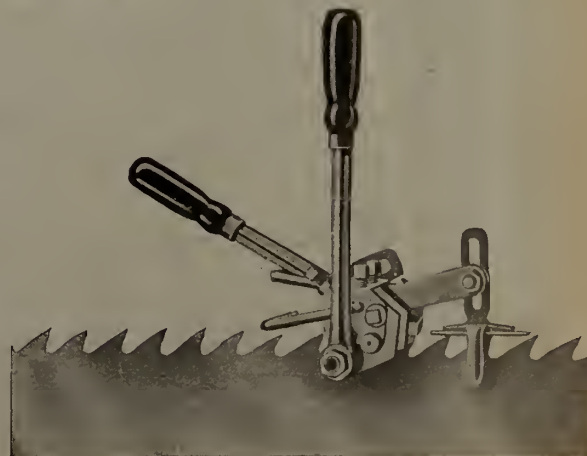

Hanchett Band Saw Swage

HANCHETT SWAGE WORKS,

Big Rapids,

Mich., U. S. A.

WE MAKE SWAGE SHAPERS.

FORESTRY DEPARTMENT

THE AMERICAN FOREST CONGRESS.

The American Forest Congress, which took place at Washington, D.C., during the first week in January, proved to be, as was expected, the most important meeting ever held on the American continent in the interest of forestry. At each of the eight separate sessions the average attendance was one thousand, including in addition to persons actively engaged in forest work, representatives from the lumbering, railroad, mining and irrigation interests. The Canadian delegates were as follows:

Dr. Robert Bell and Prof. J. M. Macoun, Geological Survey, Ottawa; Aubrey White, Deputy Commissioner of Crown Lands, Toronto; Thomas Southworth, Director of Forestry, Toronto; E. Stewart, Dominion Superintendent of Forestry, Ottawa; R. H. Campbell, Secretary Canadian Forestry Association, Ottawa; Dr. J. F. Clark, Forester for Ontario Government, Toronto; C. Y. Chown, Queen's University, Kingston; Dr. James Fletcher, Ottawa; Prof. J. H. Faull, Toronto University, Toronto; A. T. Drummond, Toronto; Norman M. Ross, Dominion Forest Service, Ottawa.

Hon. James Wilson, Secretary of Agriculture, presided, and after delivering an interesting address, called for the report of the directors of the American Forestry Association. The report referred to the steady and rapid progress which commercial forestry is making in consequence of the growing recognition by lumbermen that conservative lumbering offers definite business advantages, to which, as business men, they must give careful consideration, the day being rapidly approaching when the failure to practice forestry will mean for many of them the extinction of their business. The Bureau has received applications from land owners, who desire to secure the best results from their forest holdings, covering a total area of eight million acres, and now has under its management 20,000 acres in wood lots and 500,000 acres of timber tracts. In addition, working plans have been prepared by the Bureau for 823,000 acres and are now in preparation for

an area aggregating 3,578,514 acres. The forest reserves of the United States are given as 63,348,656 acres, eleven new reserves having been created since June 30, 1903. Forest rangers are shown to have extinguished during the past year 231 fires which had passed the incipient stage. The annual membership of the Association at the close of 1904 was 2,199.

Mr. Aubrey White, Deputy Commissioner of Crown Lands for Ontario, was called upon for an impromptu address, and described in an interesting manner the different systems in vogue for the management of the Crown forests in Canada. He mentioned that Ontario alone had set apart some 7,000,000 acres as a forest reserve and there was on these lands to his knowledge 10,000,000,000 feet of white pine, constituting one of the most valuable assets any province or state could have.

The session devoted to "The Lumbering Industry and the Forests" was one of the most interesting of the meeting. Mr. M. C. Moore, Secretary of the National Slack Cooperage Manufacturers' Association, read a paper on "The Importance of Forestry to the Woodworking Industry," and Mr. George W. Hotchkiss spoke on "The Lumber Dealers' Interest in Forest Preservation." Other papers dealt with "Lumber Statistics"; "Cooperage and its Relation to Forestry"; "Changed Attitude of Lumbermen on Forestry"; and "Pacific Coast Forests and Lumbering as Differing from Other Forests."

On Wednesday evening, January 4, the delegates and their friends attended a delightful reception given in their honor by Mr. and Mrs. J. W. Pinchot and their son, Mr. Gifford Pinchot, Forester of the United States Department of Agriculture. At the special session on Thursday there was an attendance of more than two thousand persons, the attraction being an address by President Roosevelt on "The Forest in the Life of a Nation." There were presented in all upwards of thirty papers, many of which had a direct bearing upon lumbering.

The Congress adopted a number of important resolutions, the text of some of which are given below:

Resolved, that we urge upon Congress and upon all

legislative bodies the necessity at all times of giving full protection to the forests of the country and of preserving them through wise and beneficent laws, so that they may contribute in the most complete manner to the continued prosperity of the country.

Resolved, that we earnestly commend to all state authorities the enactment and enforcement of laws for the protection of the forests from fire, and for reducing the burden of taxation on lands held for forest reproduction in order that persons and corporations may be induced to put in practice the principles of forest conservation.

Resolved, that the law which prohibits the export of forest reserve timber from the state in which it is grown should be repealed as to the states in which the export of such timber is in the public interest, and in no others.

Resolved, that we favor the passage of a law which will authorize the sale of all non-mineral products of the forest reserves, the proceeds of such sales to be applied to their management and protection, and the construction of roads and trails within the forest reserves.

Resolved, that this Congress urge upon all schools, and especially the rural schools, the necessity for a study of forests and tree-planting in their effect upon the general well-being of the nation, and in particular upon the wealth and happiness of communities through the modification of local climate; and that we urge all state legislatures to provide laws and financial aid to consolidate the rural schools in units sufficiently large that forestry, agriculture, and home economics may be successfully taught by precept, example and practical work.

Resolved, that this Congress recommends the increase of opportunities for general forest education in schools and colleges, and for professional training in post-graduate schools; and approves the movement to extend and systematize industrial education in the interest of a more general distribution of the population on the land.

Resolved, that the Congress of the United States be asked to appropriate adequate sums for the promotion of forest education and forest experimental work in the agricultural colleges and experiment stations of the United States; provided, however, such appropriations be made directly to state forestry departments, bureaus, or commissions, where existing, to be used in their respective states as may seem best for forestry educational purposes.

Resolved, that we protest against the attempt to reduce the area of the Minnesota National Forest Reserve and against any step which would enhance the difficulty of the perpetuation of the forests upon it.

Resolved, that this Congress urges tree-planting and the preservation of shade trees along public highways throughout America.

Resolved, that it is the sense of this Congress that the National Homestead Law should be amended so as to require the planting of at least 5 per cent. of the area of a homestead before final title be acquired, and that the tree planting be under the supervision of the Bureau of Forestry.

SADLER & HAWORTH
 TANNERS & MANUFACTURERS OF
OAK LEATHER BELTING
 AND LACE LEATHER
HYDRAULIC & MECHANICAL LEATHERS
 DEALERS IN GENERAL MILL SUPPLIES
MONTREAL. TORONTO.
 Corner, William & Seigneurs Sts. 9 Jordan St.

FIRE THREATENS SAWMILL DISTRICT
 Units of Three Companies Arrived Before Firemen Checked Flames

\$10,000 WORTH OF LUMBER BURNED
 Unstable July 24—Ten million feet of wood, partially sawed timber and some in log, valued at \$10,000, in the yards of

\$80,000 LUMBER FIRE
 BIG YARDS DESTROYED BY FLAMES AT BAY CITY.

COSTLY FIRE IN LUMBER
 Five Million Feet Below

CAN YOU AFFORD TO BE WITHOUT AMPLE FIRE INSURANCE?
 THE BEST INDEMNITY IS SOLD AT 66 BROADWAY BY THE **Lumber Insurance Company of New York** AND ALLIED COMPANIES

Lumber Yards Destroyed.
 Cincinnati, O., Aug. 17.—The large lumber yards and mills of C. Crane & Co., on Eastern avenue, burned today. The loss will be heavy. The fire started at the west of the yards, which extend several squares along the Ohio river front. With a strong breeze from the west the flames swept toward the Crane sawmills, and many stacks of lumber of 12,000 feet each changed so as to turn up river. Hundreds of people were watching

LUMBER FIRE AT CLEVELAND.
 CLEVELAND, September 12.—Fire last night in the yard of Nicola Stone & Myers Company. The

BIG LOSS AT LUMBER FIRE.
 Done at Johnson City Wis. out to \$90,000

BIG LUMBER YARD BURNS.
 Seven Million Feet of Material Destroyed

LUMBER FIRE IN HARTFORD.
 Spreads from Mason's Yard to Italian Tenement and Old Arsenal

PLANING MILL WAS DESTROYED
 Fire early yesterday in the planing mill of V. and M.

LUMBER FIRE IN ASHLAND, WIS.
 Barker & Stewart

BIG FIRE IN PROVIDENCE
 OVER 1,000,000 FEET OF LUMBER BURNED

\$10,000 WORTH OF LUMBER BURNED
 Tenn. Aug. 30.—(Special) of

\$10,000 WORTH OF LUMBER BURNED
 Tenn. July 4.—Ten million feet of really sweet timber and some valued at \$20,000, in the yards, was destroyed by fire early

WILSON MILL BURNED
 Big Establishment Went up in

MILL AND LUMBER BURNED
 Tenn. Aug. 30.—(Special) of

MILL AND LUMBER BURNED
 Tenn. Aug. 30.—(Special) of

LUMBER PLANT BURNED UP.
 A fire destroyed the wood working establishment, including a valuable quantity of lumber and machinery, of Joseph Lee, at 46 East Meadow street, Orange, N. J., last night, the number of hands

FIRE IN LUMBER YARD DOES \$2,000 DAMAGE
 originating from some

FIRE IN LUMBER YARD DOES \$2,000 DAMAGE
 originating from some

LUMBER YARD BURNED
 July 24.—Fire front in

SPECTACULAR
 Was Lumber Yard Blaze.

SPECTACULAR
 Was Lumber Yard Blaze.

AWMILL BURNS AT ECHO
 & Mullen Lumber Company sustain a Heavy Fire Loss

BIG PLANT DESTROYED BY FIRE
 Worth \$200,000 Left In

BIG PLANT DESTROYED BY FIRE
 Worth \$200,000 Left In

Big Sawmill Burned.
 King's sawmill at Ludwila, in this section, together with freight cars and considerable loss is more than

BIG LUMBER PLANT BURNED
 Mills and a Steamer Destroyed

BIG LUMBER PLANT BURNED
 Mills and a Steamer Destroyed

CINCINNATI LUMBER FIRE COVERED BY INSURANCE.
 List of the Policies Carried by the Crane Lumber Yards, Which Was Partially Destroyed Wednesday—Total, \$324,300.

BIG LUMBER PLANT BURNED
 Mills and a Steamer Destroyed

BIG LUMBER PLANT BURNED
 Mills and a Steamer Destroyed

\$22,000 FIRE LOSS
 At Large Milling Plant

BIG LUMBER PLANT BURNED
 Mills and a Steamer Destroyed

BIG LUMBER PLANT BURNED
 Mills and a Steamer Destroyed

\$22,000 FIRE LOSS
 At Large Milling Plant

THE TOLEDO FIRE AND MARINE INSURANCE COMPANY

of Sandusky, Ohio, and the

LUMBER UNDERWRITERS

are allied with

LUMBER INSURANCE COMPANY OF NEW YORK

They form the strongest lumber insuring combination in the business.

66 BROADWAY, NEW YORK

CLASSIFIED INDEX OF ADVERTISERS

AXES
Dundas Axe Works..... 12

ALLICATOR TUGS
West & Peachey..... 42

BELTING
Dominion Belting Co..... 38
Fairbanks Co..... 31
Gutta Percha & Rubber Mfg. Co..... 41
Goodhue & Co., J. L..... 1
McLaren, D. K..... 1
McLaren Belting Co., J. C..... 90
Sadler & Haworth..... 28
Waterous Engine Works Co..... 40
Wilby, P. H..... 12
Young, J. S..... 1

BUILDING BLOCKS
Cement Building Block Co..... 42

BABBITT METALS
Robertson Co., The James..... 44
Syracuse Smelting Works..... 21

BOILERS
Canada Foundry Co., Limited..... 12
Dyment Foundry Co..... 36

DOORS
New Century Refrigerator & Mfg. Co. 42

DRY KILNS
Andrews Co., The A. H..... 4
McEachren Heating & Ventilating Co. 43
Sheldon & Sheldon..... 43
Standard Dry Kiln Co..... 43

ELEVATING AND TRANSMITTING MACHINERY
Buhl Malleable Co..... 12
Dodge Manufacturing Co..... 6
Perrin & Co., R..... 40

EMERY WHEELS
Hart Corundum Wheel Co., Limited.. 26

ENGINES AND LOCOMOTIVES
Dyment Foundry Co..... 36
Gartshore, John R..... 42
Owen Sound Iron Works..... 40
Robb Engineering Co..... 35

EDGERS
Gordon Hollow Blast Grate Co..... 41

GRATES
Gordon Hollow Blast Grate Co..... 41

LUMBERMEN'S SUPPLIES
Johnson, A. H..... 38
Montreal Tent, Awning & Tarpaulin Co..... 42
Park, Blackwell Co..... 42
Rice, Lewis & Sons, Limited..... 44
Thompson Mfg. Co..... 1
Woods, Limited..... 1

LUMBER AND SHINGLE MANUFACTURERS
Big Bend Lumber Co..... 10
B. C. Mills, Timber & Trading Co.... 9
Canadian Pacific Lumber Co..... 8
Cloverdale Milling Co..... 8
Crows Nest Pass Lumber Co..... 8
Columbia River Lumber Co..... 8
Delta Saw Mill Co..... 10
East Kootenay Lumber Co..... 10
Fernie Lumber Co..... 18
Great Northern Lumber Co..... 19
Hadden, D. & J..... 10
King Lumber Mills..... 8
Ladysmith Lumber Co..... 9
Moyle Lumber & Milling Co..... 8
North Star Lumber Co..... 10
Pigeon River Lumber Co..... 10
Sayward, J. A..... 9
Victoria Lumber & Mfg. Co..... 10
Yale-Columbia Lumber Co..... 8

LUMBERMEN'S TOOLS
Baldwin, Tuthill & Bolton..... 4
Burton Saw Co., J. A..... 37
Hamacher, Schlemmer & Co..... 22
Hamilton Stamp and Stencil Works... 44
Hay Knife Co., Peter..... 10
Pink, Thomas..... 44

MISCELLANEOUS
Alexander Engraving Co..... 1
Bradstreets..... 30
Canadian Office & School Furniture Co. 30
Denton, Dunn & Boulton, Barristers. 40
Fielding, J. S., Consulting Engineer.. 1
Glenyards Fire Clay Co..... 33
Georgian Bay Engineering Works—
Grinders..... 43
Huther Bros.—Dado Heads..... 30
International Correspondence School.. 37
Lumber Mutual Fire Insurance Co.... 32
McFarlane-Neill Mfg. Co.—Cant Dogs. 33
Metallic Roofing Co.—Corrugated Iron 24
Spence & Co., R.—Files and Rasps.. 42

Scribner's Lumber & Log Book..... 12
Toledo Fire Insurance Co..... 29
Vogel, C. H.—Pulp Mill Engineer..... 23

OILS
Commercial Oil Co..... 40
Canadian Oil Co..... 21
Queen City Oil Co..... 30

PROVISIONS
Clark, Wm..... 22
Eckardt & Co., H.P..... 24

PORTABLE SAW MILLS
Drake, F. J..... 36
Oxford Foundry & Machine Co..... 40
Owen Sound Iron Works..... 41

PLANERS AND MATCHERS
Clark & Demill..... 11

PULLEYS
Dodge Manufacturing Co..... 6

PACKING AND PIPE COVERING
Eureka Mineral Wool & Asbestos Co. 33
Garlock Packing Co..... 12
Purvis Co., E. L..... 35

ROPE
Canadian Cordage Co..... 31
Consumers Cordage Co..... 32
Dominion Wire Rope Co..... 12
Greening Wire Co., B..... 1
Mussen & Co., W. H. C..... 1

RE-SAWS
Cowan & Co..... 31

SAW SWAGES
Crowell, D. J..... 32
Hanchett Swage Works..... 27

SAW GAUCES
Specialty Mfg. Co..... 40

STEAM BOILERS
Canada Foundry Co..... 12
Owen Sound Iron Works..... 41

SAWS
Atkins & Co., E. C..... 35
Burns Saw Co., E. R..... 1
Buckeye Saw Mfg. Co..... 21
Hoe & Co., R..... 41
Oldham & Sons, Joshua..... 5
Shurley & Dietrich..... 3

SAW MILL MACHINERY
Bartlett & Co., A. F..... 40
Dunbar & Sons, Alex..... 4
Furniture City Tool Co..... 43
Hamilton Mfg. Co., Wm..... 2
Long Mfg. Co..... 7
Mershon & Co., W. B..... 42
Mowry & Sons, B. R..... 38
Owen Sound Iron Works..... 41
Oxford Foundry & Machine Co..... 40
Petrie, H. W..... 44
Payette & Co., P..... 32
Schaaque Machine Works..... 4
Smart-Turner Machine Co..... 44
Waterous Engine Works Co..... 34
Williams, Madison..... 6

SHINGLE MILL MACHINERY
Dunbar & Sons, Alex..... 4
Drake, F. J..... 36
Long Mfg. Co., E..... 7
Owen Sound Iron Works Co..... 41
Schaaque Machine Works..... 4
Williams, Madison..... 6

TURBINES
Williams, Madison..... 6

TRIMMERS
Gordon Hollow Blast Grate Co..... 41

WOODWORKING MACHINERY
American Woodworking Machinery Co..... 39
Clark & Demill..... 11
Connell & Dengler Machine Co..... 38
Coe Mfg. Co., The..... 11
Cowan & Co., Limited..... 31
Dodge Manufacturing Co..... 6
Defiance Machine Works..... 11
Mitts & Merrill..... 31
Perkins & Co..... 38
Rogers Iron Mfg. Co..... 37
Sherman Co., W. S..... 40
Shimer & Sons, Samuel J..... 37
Waterous Engine Works Co..... 34

The . . .

QUEEN CITY OIL CO.

LIMITED

Head Office: TORONTO.

HIGHEST GRADES OF

Refined Oils Lubrication Oils

AND ALL

Petroleum Products

CANADIAN OFFICE & SCHOOL FURNITURE CO. LIMITED
PRESTON ONT.

FINE BANK OFFICE COURT HOUSE & DRUG STORE FITTINGS. OFFICE SCHOOL CHURCH & LODGE FURNITURE. SEND FOR CATALOGUE.

ESTABLISHED 1849.

BRADSTREET'S

Capital and Surplus, \$1,500,000.

Offices Throughout the Civilized World.

Executive Offices:
Nos. 346 and 348 Broadway, NEW YORK CITY, U.S.A.

THE BRADSTREET COMPANY gathers information that reflects the financial condition and the controlling circumstances of every seeker of mercantile credit. Its business may be defined as of the merchants, by the merchants, for the merchants. In procuring, verifying and promulgating information, no effort is spared, and no reasonable expense considered too great, that the results may justify its claim as an authority on all matters affecting commercial affairs and mercantile credit. Its offices and connections have been steadily extended, and it furnishes information concerning mercantile persons throughout the civilized world.

Subscriptions are based on the service furnished, and are available only by reputable wholesale, jobbing and manufacturing concerns, and by responsible and worthy financial, judiciary and business corporations. Specific terms may be obtained by address r. the company or any of its offices. Correspondence invited.

THE BRADSTREET COMPANY.

OFFICES IN CANADA: Halifax N.S. Hamilton, Ont. London Ont.; Montreal, Que.; Ottawa, Ont.; Quebec, Que.; St. John, N. B. Toronto, Ont. Vancouver, B.C.; Winnipeg, Man.

THOS. C. IRVING,
Gen. Man. Western Canada, Toronto

Scribner's Lumber and Log Book

A handy book for Lumbermen. Gives Correct Measurements of Scantlings, Boards and Planks; Cubical Contents of Square and Round Timber; Doyle's Rules, and much other practical information.

ADDRESS THE CANADA LUMBERMAN, Toronto, Ont. Price 35 Cents

HUTHER BROS. PATENT GROOVER OR DADO HEAD

For cutting any width groove from 1/4-inch to 2 inches or over



Can be used on any Circular Saw Mandrel. Will cut a perfect groove with or across the grain.

This is the only Dado Head on the market that gives entire satisfaction on all classes of work. No screw adjustment. For different width grooves, simply remove or add inside cutters. Sold by builders and dealers of woodworking machinery in all parts of the United States. Will send on approval, in competition with any other make on the market; if not the best return at our expense. HUTHER BROS., Platt Street, ROCHESTER, N.Y., manufacturers of Circular Saws, Morgan Pattern Lock-Corner Box Cutters, Concave Saws, etc.

PURE MANILA ROPE

Highest Quality Made

BRITISH MANILA

SISAL ROPE

Pure Sisal

LATH YARN

WIRE, WRITE OR PHONE



Canadian Cordage & Manufacturing Company, Limited

Peterboro, Ontario, Canada

Long Distance Phone 162

Our Rope and Lath Yarn are Recognized as the Best on the Market.

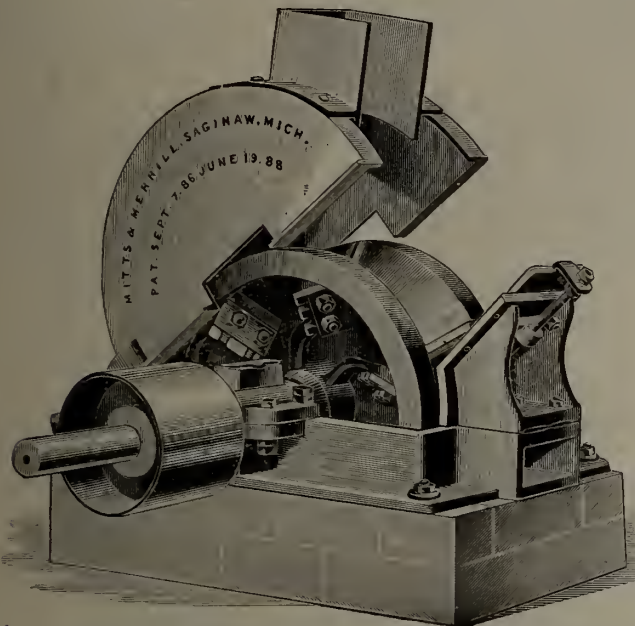

We Make **“HOG”** For Cutting

Slabs, Edgings and Blocks, Shingle, Sawdust and Splints, Planing Mill and Box Factory Refuse, Heading and Veneer Mill Waste, into fuel chips. Extract Chips into fine chips. Millions of dollars saved by their use. Try One.

MITTS & MERRILL

807 Tilden Street, - - - Saginaw, Mich.

SEND FOR CIRCULAR E

Cowan & Co. of Galt, Limited

GALT, CANADA

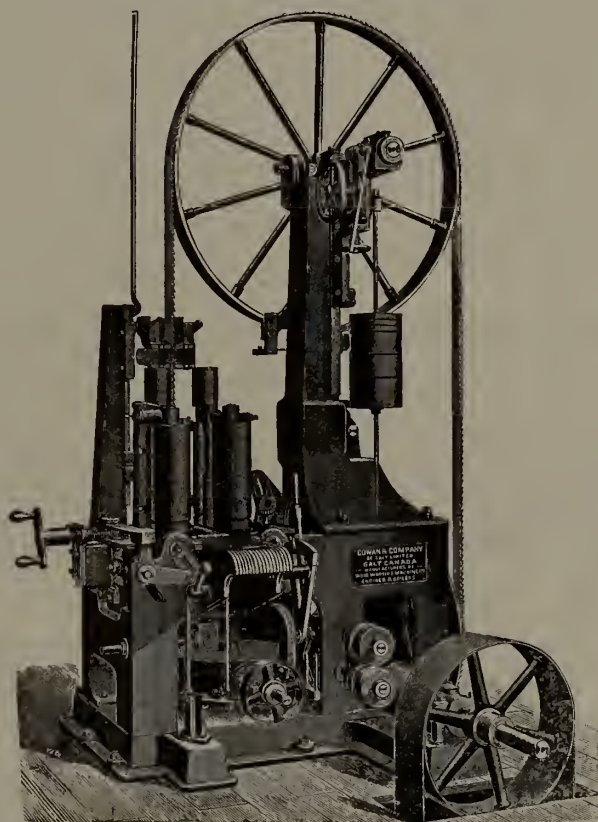

No. O Band Resaw, M167

We build this machine in different styles and sizes, with wheels 42", 48", 54" and 60" diameter. Also a full line of the most up-to-date Wood Working Machinery of superior material and workmanship.

Write for cuts and prices.

WHEN FIXING UP YOUR MILL

For next spring's business we would like to hear from you regarding the Belting you will doubtless require. In the manufacture of

FAIRBANKS'  BRAND LEATHER BELTING

we think we have attained a higher degree of excellence than was heretofore obtainable. We use nothing but the best Packer's Butts and then only the toughest part of these. The belly and the working parts of the animal we do not use at all, and every belt from six inches up has the backbone strip of the animal in it. We carry a complete stock and can make prompt shipment. Write to us about it.

The Fairbanks Co.

Montreal

Toronto

Vancouver

Winnipeg



THE IRISHMAN'S CANT HOOK.

A farmer, accompanied by several of his hired men, went into the woods one morning in the fall of the year to cut down some trees. When about to begin work it was discovered that the cant hook had been left behind. Turning to one of the men, an Irishman not very long over, the farmer instructed him to drive back to the farm for the missing tool. The Irishman did not know what a cant hook looked like, but was averse to exposing his ignorance, so drove off on his errand, trusting to find someone at the farm who would enlighten him.

At the barn, however, there was no one to help him out of his dilemma. Casting his eyes about the place for the thing which would be likely to bear the name of "cant hook," he saw a mooley cow with never a sign of a horn upon its head, and concluded it was that he had been sent for.

Procuring a rope, he fastened the cow to the rear end of his vehicle and exultingly drove back to the woods.

"What in Sam Hill have you there?" shouted the farmer on seeing his messenger and the cow. "I sent you for a cant hook to use in

moving the logs; what have you brought that cow for?"

"Be jabbers, boss, divil another thing could I see around the barn that can't hook but this." Star of Hope.

A SHORT TOTE ROAD

Even a long tote-road seems short after eating CLARK'S CORNED BEEF. None but the best prime Canadian beef ever enters the establishment of

WILLIAM CLARK, MONTREAL

P. PAYETTE & CO.

Manufacturers of Saw Mill and Engine Machinery and all kinds of Marine Machinery.

PENETANGISHEN, ONT.

THE LUMBER MUTUAL FIRE INSURANCE COMPANY

BOSTON, MASS.

STRENGTH

NET ASSETS, DECEMBER 31, 1904

\$578,390.30

ECONOMY

DIVIDENDS TO POLICY HOLDERS

33 $\frac{1}{3}$ %

MAIL EXPIRING POLICIES WITH YOUR ORDER.



These Mules Cannot Break This Yarn

BECAUSE IT WAS MADE BY THE

Consumers Cordage Co., Limited

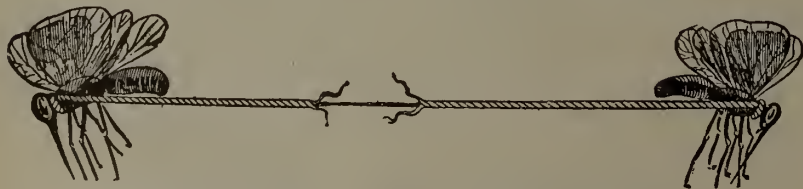

Poor Yarn is Dear at Any Price

We Manufacture

**Double and Single Lath Yarn,
Shingle Yarn, and Cordage**

Of Every Description

Our mills are equipped with the latest improved machinery for making extra long lengths of Transmission Rope.

CONSUMERS CORDAGE CO., LIMITED
Montreal and Halifax

Crowell Saw Swages

Our Swages are conceded to be the finest ones on the market to-day and are giving perfect satisfaction wherever used.

The **CROWELL SWAGES** are easily adjusted and simple to manage they spread and swage the teeth with the **LEAST WASTE** of any **SWAGE** on the **MARKET**.

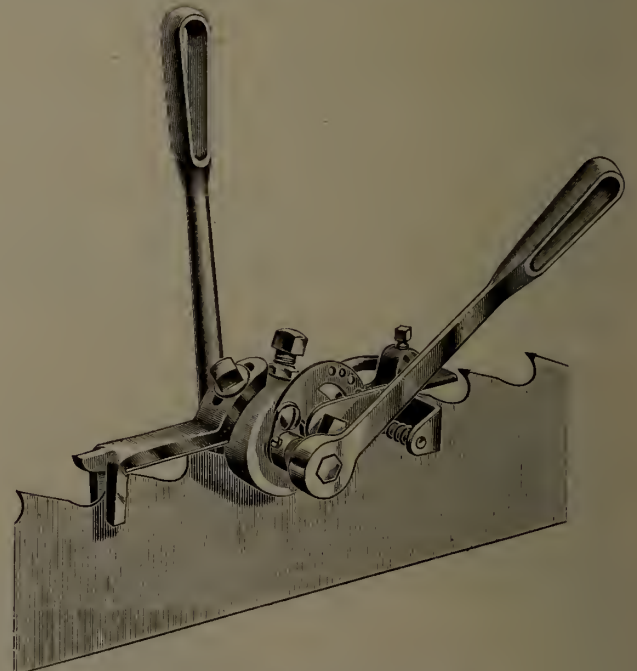

Cut Showing Band Saw Swage.

Our Swages work equally well on Band or Circular Saws, and do perfect work without front guard or back-stop, although these are convenient and always supplied.

We make **NOTHING BUT SAW SWAGES**, and use the finest material obtainable in manufacturing.

Our Swages have many points of superiority over all other makes. A "**Crowell Swage**" used on your saws will enable you to make more and better lumber.

Let me send you reference of some who have used them.

D. J. CROWELL, 200 The Terrace
BUFFALO, N. Y.

Cost of Lubrication reduced 30 to 50 per cent.

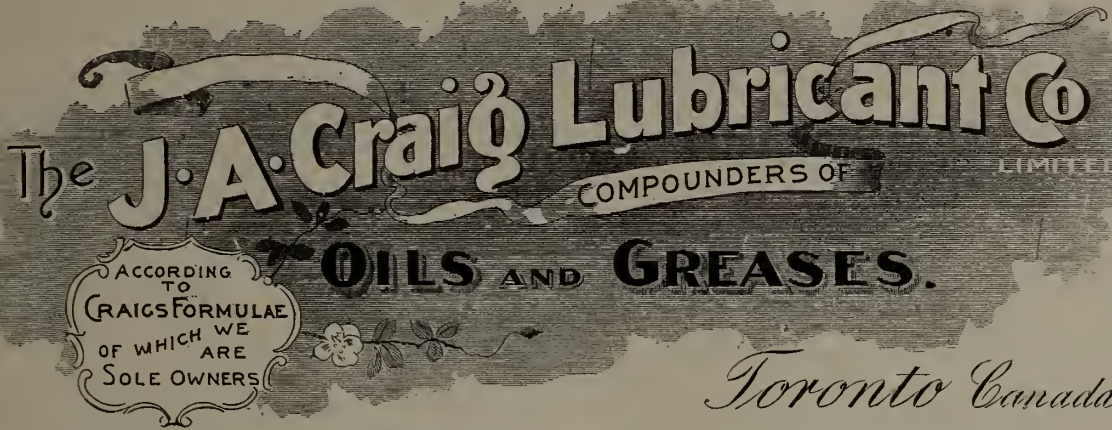

We Can
do the same
for You

Toronto Canada.

Read
following
Testimonials
for Proof.

TORONTO, October 24th, 1904.

THE J. A. CRAIG LUBRICANT CO., Limited,
Toronto, Ont.

GENTLEMEN,—It is with great pleasure we testify as to the practical value of your Cylinder and Engine Oils, also your compounded greases, as your goods have certainly been a surprise to us.

We adopted your system of lubricating at our mills and on our boats at French River for the season of 1904 and on comparing this year's accounts to date we find you have reduced our oil and grease account to one half what it has been in former years, and this in the face of additional machinery recently installed and the output of our mills having been greatly increased.

Not once during the whole season have we been troubled with a hot journal, our first experience of this sort in years.

We have one man only to do the oiling for our entire plant and he appears to have an easy time.

So long as you continue to supply us with goods equal to what we have had from you this season, you can depend upon receiving all of our trade in this line.

You are at liberty to make use of this letter in whatever way you wish, as we really feel grateful for what you have done for us at our mills.

Yours truly,
THE ONTARIO LUMBER CO., Limited.
H. H. Cook, President.

BYNG INLET, AUGUST 13TH, 1904.

MR. J. A. CRAIG:

Dear Sir, or to whom it may concern,—I have been using your cylinder oil on our 600 horse Corliss Engine in our saw-mill as a test for the last three weeks and I can honestly say I can run on less oil than half and with better results than with any other oil I have ever tried, in fact the metal is so soft in this engine no kind of cylinder oil (Vacuum included) we could buy in Canada would do. The only oil we could use was Harris Oil imported from Boston, U. S. A.

The longest a one gallon lubricator of Harris Oil would run was seven hours, while your cylinder oil would run twenty-one hours with better results. I tried the oils in our other big Corliss with even better results, and as long as you compound your cylinder oils and have them as good as samples I shall use no other.

Your compression cup grease is excellent and your pure fat for enriching mineral oils makes everything run safe. I therefore highly recommend them.

Yours truly,
JAMES TATE,
Chief Engineer Holland & Graves Lumber Co.
Byng Inlet, Ontario.

We Are Headquarters for Engine Packings, Pipe and Boiler Coverings Etc., Etc., Etc.

Cling Surface
for
Belts and Ropes

Smooth-On
for
Iron Repairs



Asbestos
in all its forms

Insulating
Materials
and Papers

Paroid, Vulcanoid and Red Rope Ready Roofing

EUREKA MINERAL WOOL AND ASBESTOS CO. TORONTO

FOR SALE

AT FERNIE, B. C.

SAW MILL PLANT and TIMBER LIMITS

1827 Acres one and a quarter miles from Fernie, B. C., heavily timbered with Fir, Cedar, Spruce and Tamarac, easily accessible for logging purposes both in Summer and Winter.

SAW MILL, WATEROUS MILL with Capacity of Forty Thousand Feet Per Day, with Planers, Lath Mill, etc., all complete.

STABLES, Dwelling Houses, Store, Smithy and Logging Camp, all substantially built and ready for occupation.

The limits are held under Crown Grant and purchaser can enter and begin operations without any delay.

For further particulars, price, terms, etc., address

P. H. VIBERT, Esq.,

Manager Union Bank of Canada, LETHBRIDGE, N. W. T.

or *H. B. GILMOUR, Esq.,*

Molsons Bank Building, VANCOUVER, B. C.

Waterous Engine Works Co., Brantford Canada

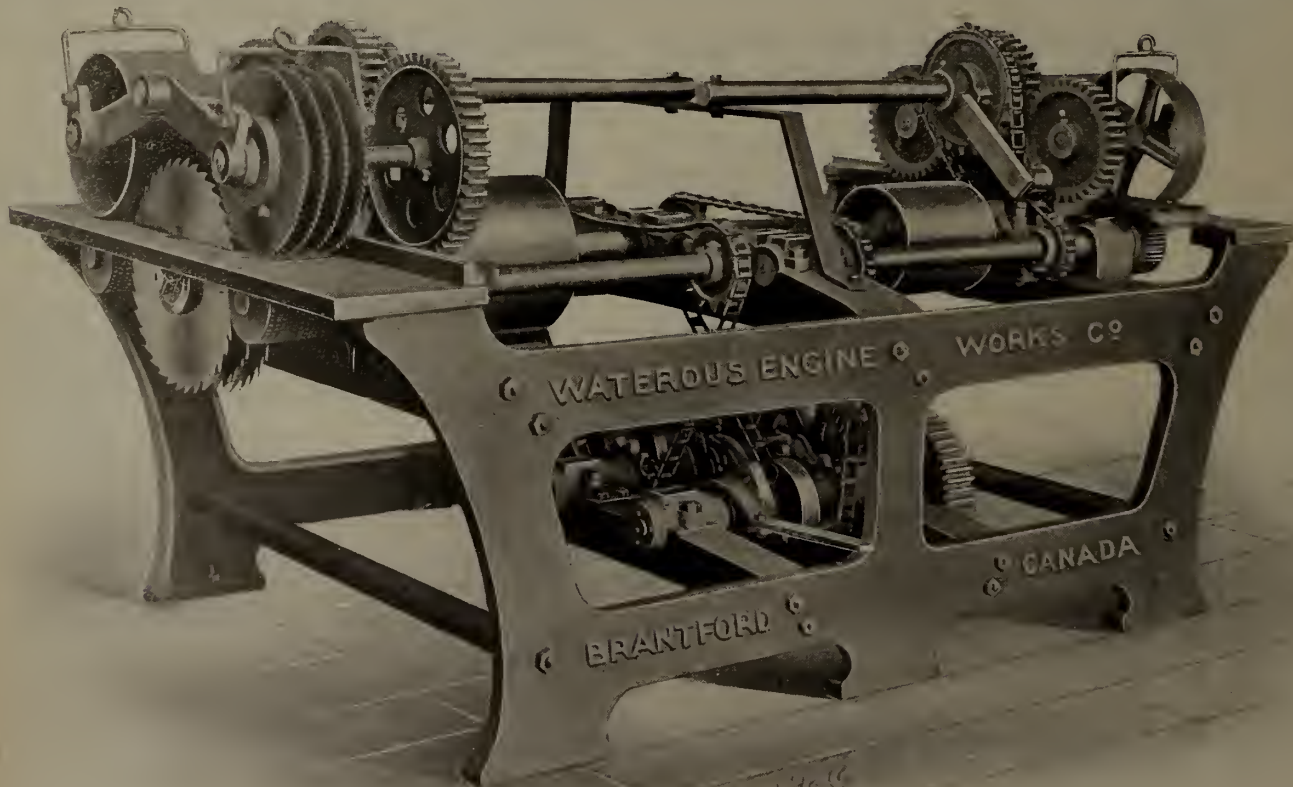

Two idler pulleys supplied, enabling lath saws to run reverse to bolter saws.

✻ ✻

After passing bolter saws, bolts are pushed continuously on skids to lath operator's right hand.

✻ ✻

Separate Lath Machine and Bolter are the same machine, but divided.

Combined Lath Mill and Bolter With independent and adjustable feed. Capacity 50,000 lath per day. Write for price and catalogue. All rolls upper and lower power driven.

THE DISTINGUISHING MARK

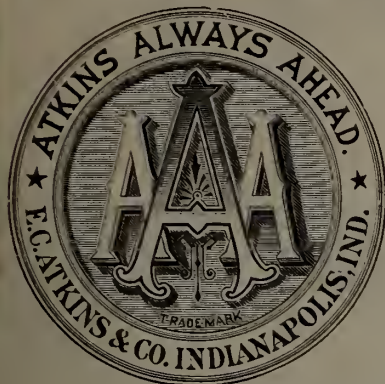

To install in your mill a set of saws that will suit you in every particular, it is necessary that you be familiar with some means of distinguishing the **HIGH-LASS SAWS** from the others. Knowing some such mark you will always disseminate in favor of the saw which bears that mark of **QUALITY**.

THE ATKINS "TRIPLE A" etched on all **HIGH GRADE SILVER STEEL CIRCULAR and BAND SAWS**, is the sign which assures **QUALITY, EXCELLENCE** and absolute **SUPERIORITY** in Saws. "IF IT'S SILVER STEEL IT'S AN ATKINS." Look for our trade mark.

A little reminder of the "TRIPLE A" in the way of a pretty watch charm to Mill Men who write for it. Also our Mill Supply Catalogue. Both free.



E. C. ATKINS & CO., Inc.

Factories and Home Office,
Indianapolis, Ind.

Canadian Branch,
30 Front St. East, Toronto, Ont.

THE E. L. PURVIS CO.,
18 COLBORNE ST. TORONTO, ONT.



PIPE AND BOILER COVERINGS

Asbestos Mineral Wool
and all kinds of Fireproofing

Material Agents for

FAMOUS MICA COVERINGS

Fire Clay Products

THE GLENYARDS FIRE CLAY CO.

BONNYBRIDGE, SCOTLAND.

Cablegrams: Glenyards, Bonnybridge.

Codes used, A.B.C. and Glenyards.

Manufacturers of all kinds of **Fire Clay Goods, Ganister and Silica Goods**, for **Iron and Steel Works and Gas Works**, including **Boiler Seating Blocks and Covers** of all sizes. **Ground Fire Clay, Ganister and Silica** In all kinds of Packages

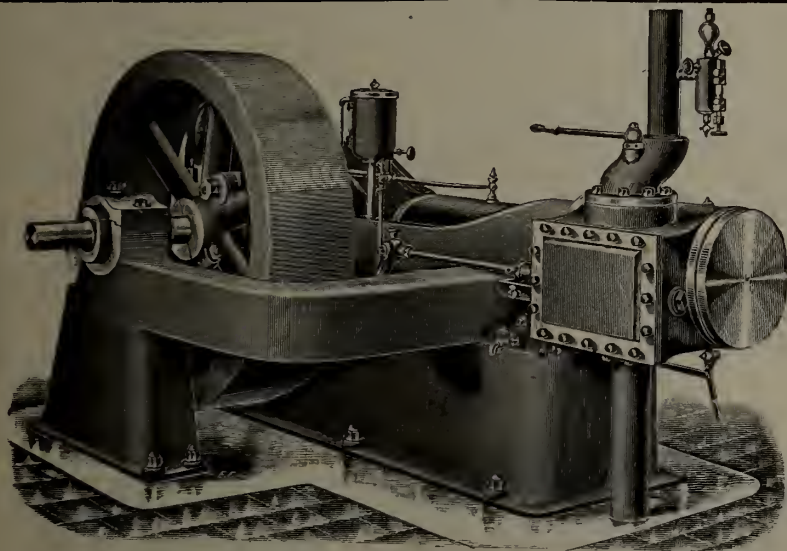

GIVES NO TROUBLE

A mill owner writes us: "The 16x16 Robb-Armstrong Automatic Engine installed in our saw mill in 1903 has proved very satisfactory. It has been running steadily five-months each sawing season of 1903 and 1904 and has given us no trouble whatever. We drive with it a large rotary, lath mill, patent haul-up, complete sawdust conveyor throughout the mill, live rolls, trimmers, slab saws and planers. We do not have to develop its full power to do this work. The governor is very sensitive, there being only a variation of 3 per cent. when saw is running in and out of cut. We use steam feed to drive our rotary and put through the mill 750 to 800 logs per day."

ROBB ENGINEERING CO., Limited, Amherst, N.S.

Agents: { William McKay, 320 Ossington Avenue, Toronto.
Watson Jack & Company, Bell Telephone Building, Montreal.
J. F. Porter, 355 Carlton Street, Winnipeg.

IN OUR LINE WE LEAD

McFarlane Patent Wrot Forged Steel Socket Cant Dogs

Leads them All 



Used in every Lumbering District from the Atlantic to the Pacific Ocean

Extra Fine Quality Split Rock
Maple Handles

Round and Duck Bill Peaveys and
Cant Hooks

Write for quotations. If once used you will never return to the old malleable sockets.

THE McFARLANE-NEILL MANUFACTURING CO., Limited ST. MARY'S, YORK COUNTY
New Brunswick



THE DYMENT FOUNDRY CO.

BARRIE, ONT.

Manufacturers of

ENGINES, BOILERS, STEAM FEEDS

AND A COMPLETE LINE OF

SAW, SHINGLE AND
LATH MILL MACHINERY

Can ship mills in a week's notice. Write us
for prices and catalogue.

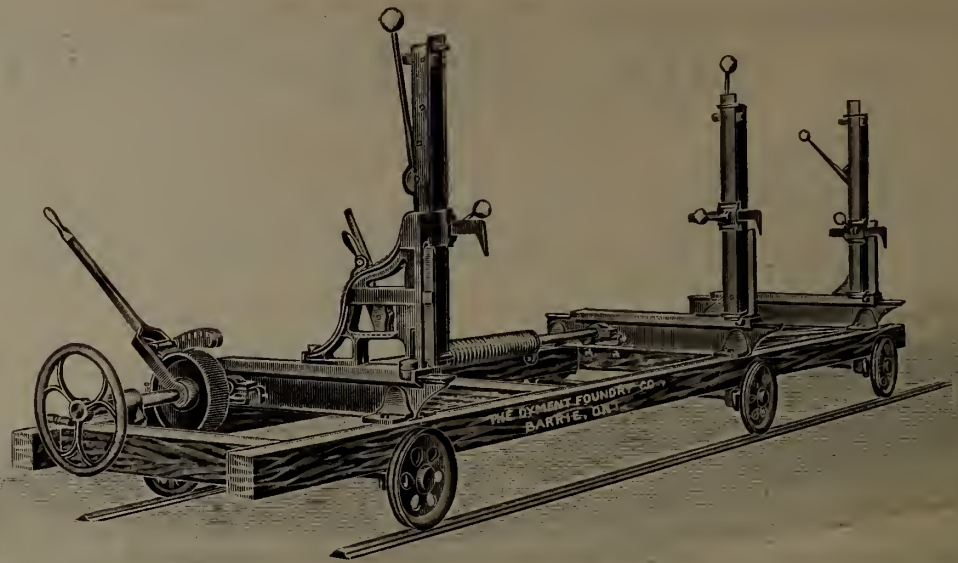

This is a light running Carriage and is quite suitable for small mills. Its capacity is about 15,000 feet per day. The wheels are 14 inches in diameter. The axles are $1\frac{3}{4}$ inches in diameter and go across frame. They are fitted with self-oiling boxes. The bunks are of steel. Blocks will recede 38 inches. An overset lever is supplied when desired, also spring receder and band brake wheel.

The feed on this frame is self-contained and can be used for either rope or rack and pinion. All the frictions have 7 inch face, two of them are made of paper, the other two of iron. The mandrel is made of steel and is 3 7-16 inches in diameter. The mandrel pulley is made in different sizes so as to suit the speed and width of drive belt. If desired this pulley may be put inside of frame.

WE MANUFACTURE AN IRON SAW FRAME

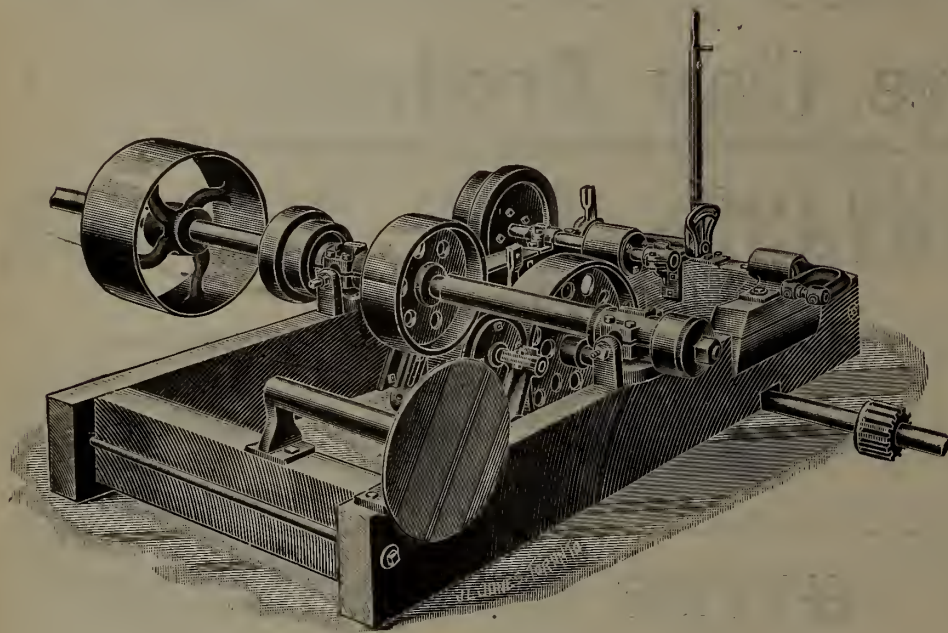

F. J. Drake's

SAW AND SHINGLE MILL MACHINERY

STATIONARY SAW MILLS
PORTABLE SAW MILLS
SHINGLE AND HEADING MACHINES
SHINGLE AND HEADING JOINTERS
TIE MILLS
LATH AND PICKET MACHINES
LATH BOLTERS
LOG JACKS AND CHAINS
SAW GUMMERS
DRAG SAW MACHINES
SHAFTING, PULLEYS, ETC.

Complete Outfits of Mill Machinery
at Bottom Prices

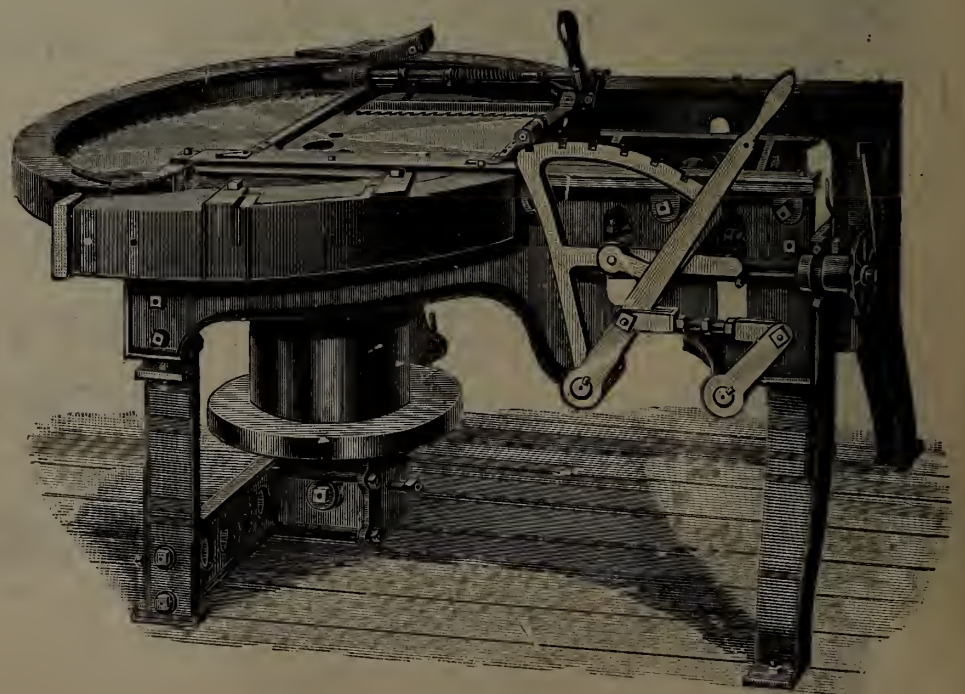

Capacity 25,000 to 50,000 per day.

F. J. Drake. BELLEVILLE,
ONTARIO

THE A. J. BURTON SAW CO.

LIMITED
Vancouver, B. C.

Inserted-tooth, Shingle and Band

SAWS

File-room Machines and Tools,
Emery Wheels,
Silver Solder, etc.

BITS AND SHANKS

BRITISH COLUMBIA AGENTS FOR R. HOE & CO.

REPAIRS executed promptly by expert workmen.
INSERTED-TOOTH SAWS REMILLED & REFITTED.

WE ARE HERE ON THE GROUND.

SAVE FREIGHT AND DUTY
TRY US.



A Millstone About the Neck

Lack of special training is the "millstone about the neck" of most carpenters and wood workers in poor paying positions. It holds them back while others go ahead. It handicaps them everywhere. The International Correspondence Schools' system of training by mail will enable you to throw off the burden. By this method thousands of ambitious carpenters and wood workers have been able to advance in place and salary. Many have been able to change their occupation, taking positions in their chosen profession. We enable young people to commence work at better salaries than if they started without training.

The accounts of the rise of some of our students read like romance. Many have risen from the lowest to the highest positions in their calling.

Decide today to better your condition—then let us help you. What we have done for others we can do for you.

Mark X before the position that interests you, fill in the coupon and send it to us. We will send you full particulars.

INTERNATIONAL CORRESPONDENCE SCHOOLS Box 1001, Scranton, Pa.

Please send me your booklet, "1001 Stories of Success," and explain how I can qualify for the position before which I have marked X.

Architect Architectural Draft'g Contractor & Builder Building Inspector Mechanical Engineer Mechanical Drafts. Electrical Engineer Dynamo Tender Telephone Engineer Steam Engineer Civil Engineer Surveyor	Sanitary Engineer Chemist Ornamental Designer Bookkeeper Stenographer Show-Card Writer Ad Writer French } With German } Phonog- Spanish } raph Commercial Law Civil Service Exams.
---	---

Name _____
St. & No. _____
City _____ State _____

The Shimer Gutter Heads WITH EXPANSION

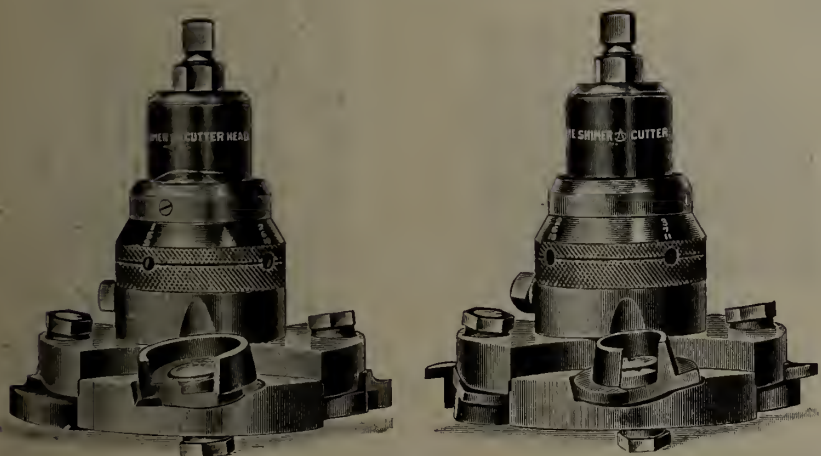

Are built from forgings of Steel and finished throughout in the solid metal. This insures accuracy, durability and perfect mechanical adjustments.

They are appreciated by the user because they hold up under the severest tests. They cut easily all kinds of hard, knotty and cross-grained lumber. If you make single tongue and groove Flooring, Ceiling and Wainscoting, buy THE SHIMER CUTTER HEADS and you will have no disappointment. Address

SAMUEL J. SHIMER & SONS
Milton, Pennsylvania

THE BEST IN THE WORLD

There is no doubt about the fact that the

RODGERS Adjustable Log Siding Machine

is without a peer.

This machine will slab opposite sides of a log in one operation at the rate of two thousand logs in 10 hours.

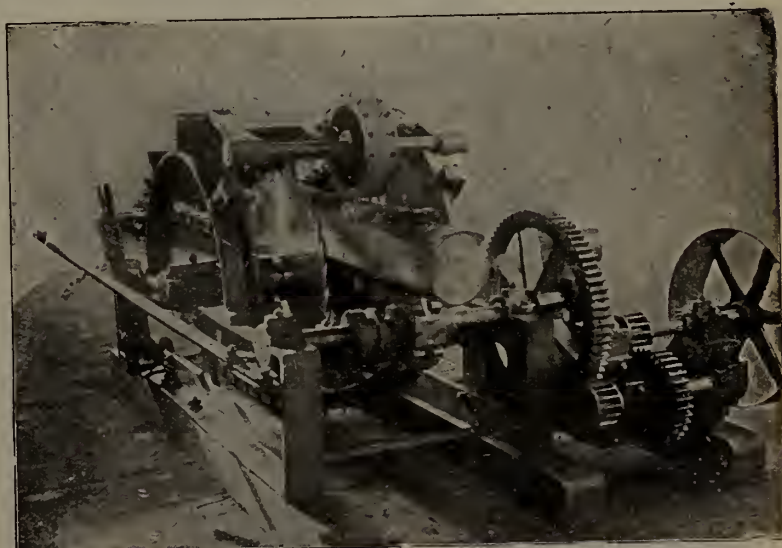

A MONEY MAKER

A MONEY SAVER

HUNDREDS OF LETTERS RECEIVED LIKE THIS :

Rock Island, Ill., Nov. 25, 1902.

RODGERS IRON MANUFACTURING CO., Muskegon, Mich.

Gentlemen:—Replying to yours of recent date and referring to your adjustable log siding machine, must say it has given us general satisfaction, and we have done good work with it. Any one desiring a machine of this style for the purpose of slabbing small logs, we would recommend yours. Respectfully,
WEYERHAUSER & DENKMAN.

For full particulars and literature, mention this paper and address :

RODGERS IRON MFG. CO.
MUSKEGON, MICH.

Reliable Veterinary Remedies

No logging outfit is complete without a supply of reliable veterinary remedies. Getting the wrong kind means the loss of the use of your horses when time is valuable.

Johnson's Veterinary Remedies are guaranteed never to fail when used as directed. You get your money back if they ever do.

Johnson's Horse Liniment No. 1.
A penetrating Alcoholic Liniment. Put up in one gallon jugs, with full directions, per imperial gal. \$4.50

Johnson's Horse Liniment No. 2.
A combination of the best oils used as liniments, imp gallon . . \$3.00

Johnson's Horse Colic Remedy.
A sure and speedy cure for colic. Imperial gallon \$5.00

Johnson's Veterinary Healing Ointment.
Positively the best all-round healing ointment made. In use by the largest owners of horse flesh in Canada. Put up in 2 lb tins, each . . \$2.00
or in 1/4 lb tins, per dozen . . \$3.00

Johnson's Condition Powders. (Concentrated).
Put up in bulk, per lb 3c.

These goods being put up in bulk are more economical than others, as cost of bottling, etc., is saved.

CAMP REMEDIES.

In addition to our Veterinary Remedies we make a line of medicines for lumbermen, including a strong, penetrating liniment, healing ointment, cholera cure, liver pills cough syrup, in fact anything in the form of Camp Drug Supplies. We know that there are no better remedies made than those we offer. There may be others nearly as good, but they lack our guarantee. Satisfaction or money back. A trade discount of 10% allowed off all orders amounting to \$100.

Send postal for printed matter.

A. H. JOHNSON
Wholesale Druggist
Collingwood, Ont.

MADE IN CANADA

STITCHED COTTON DUCK BELTING



SUPERIOR TO ALL OTHERS
—FOR—

Agricultural Machines, Elevators,
Pulp and Paper Mills, Cotton, Wool-
len, Cement and Saw Mills, Machine
Shops and Electric Powers.

MANUFACTURED BY

DOMINION BEETING COMPANY

Limited

HAMILTON, CANADA

USE OUR

"MAPLE LEAF BELT DRESSING"

IT'S OUT

Our New XXXX Cata-
log is just out, showing and
describing the most complete
and comprehensive line of
Hand and Power Feed
Shingle, Heading and Box
Board Machinery ever
created. This book is

YOURS FOR THE ASKING

and should be in the hands
of every manufacturer of
Shingles, Heading or Box
Boards in the country. A
postal request brings it.

PERKINS & CO.

GRAND RAPIDS, MICH.

GANT FLIPS - - - BOARD FLIPS

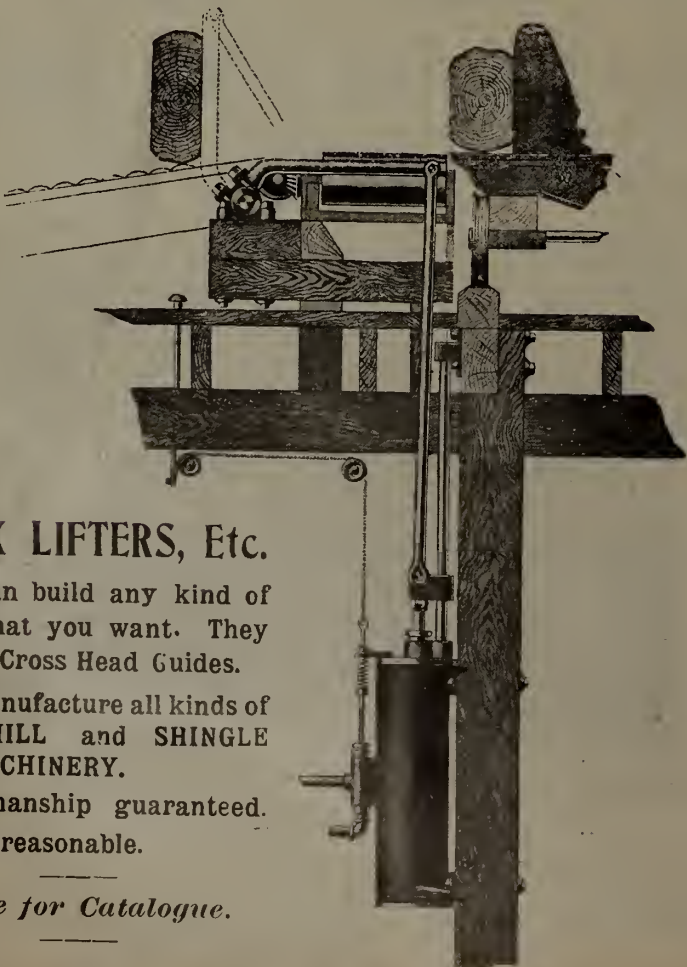

STOCK LIFTERS, Etc.

We can build any kind of
a Flip that you want. They
all have Cross Head Guides.

We manufacture all kinds of
SAW MILL and SHINGLE
MILL MACHINERY.

Workmanship guaranteed.

Prices reasonable.

Write for Catalogue.

B. R. MOWRY & SONS,
Gravenhurst, ONT.

Gonnell & Dengler Machine Co.

ROCHESTER, N. Y.

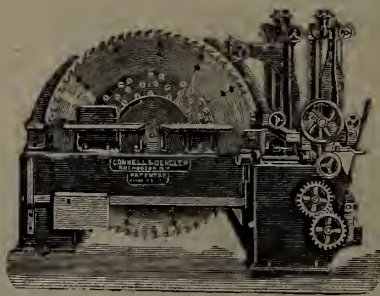

44 inch Circular Re-Saw.



60 inch Band Re-Saw

Manufacturers
of . . .

Box Makers' and Planing Mill Machinery



Heavy 25 inch Divided Roll Planer and Matcher with 8 Feed Rolls.

Are You in Need
of a Good — **Double Surfacers**

A machine which will do first-class work on any grade of lumber.

IF SO, OUR **AMERICAN** NO. 50
26X8 INCHES **DOUBLE SURFACER** WILL FILL THE BILL

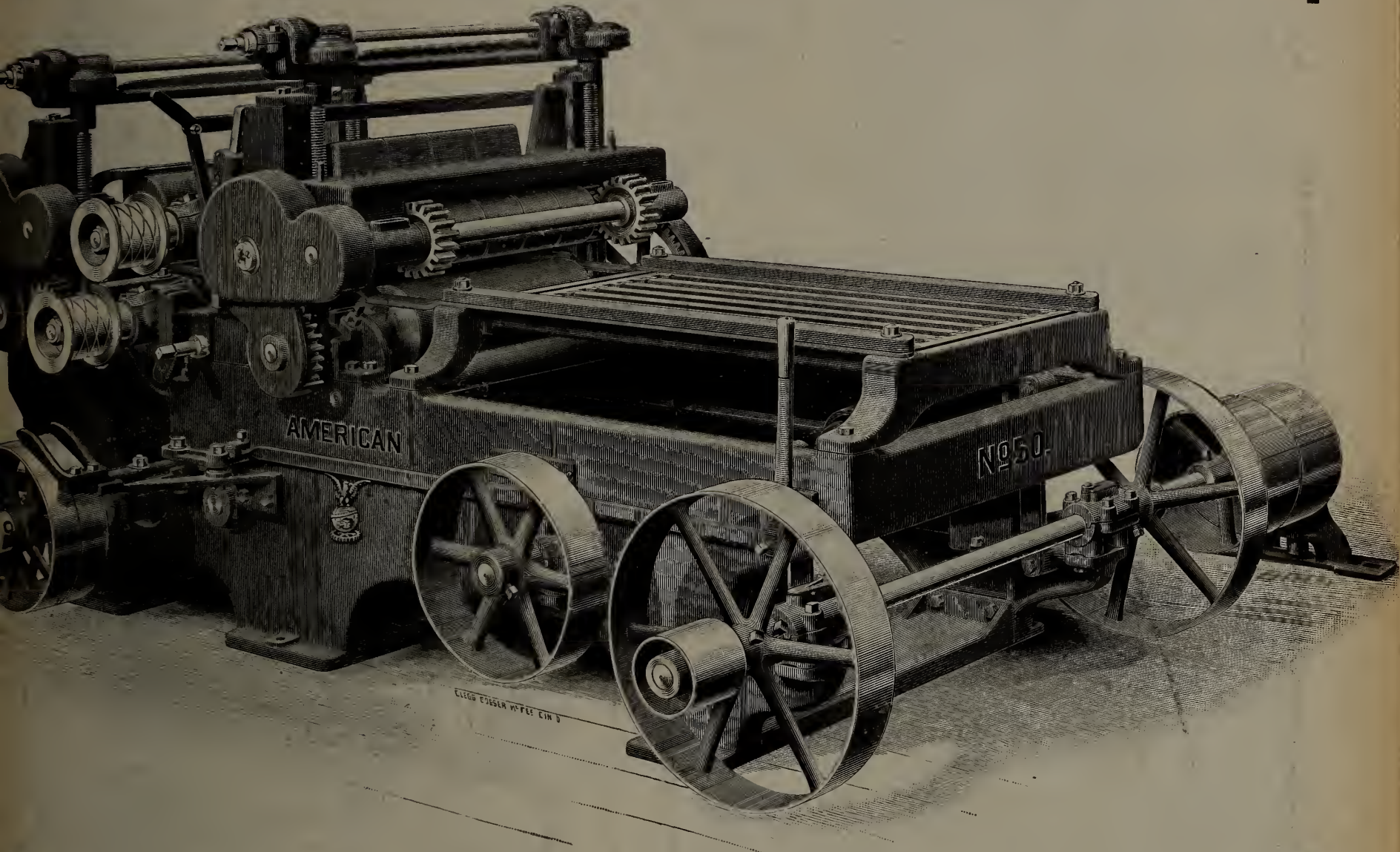

We have brought out this machine to meet a large demand for a Double Surfacers which will do first-class work on any grade of lumber. It is simple in construction with no parts to get out of order, and contains every late improvement.

It has Divided Roll and Chip Breaker, permitting the surfacing of unevenly sawed lumber, or two boards of different thickness at one time.

It has Four Feed Rolls, with strong, heavy, wide-faced Gears, which, together with belts of ample length, make it a rapid and powerful feeder.

The Upper and Lower Cutter Heads are close together, which permits the feeding of short pieces.

All parts of the machine are easy of access and all adjustments can be made quickly.

AMERICAN WOODWORKING MACHINERY CO.

NEW YORK, 136 Liberty Street.

Detachable Chain Belt

—AND—

CONVEYING

MACHINERY

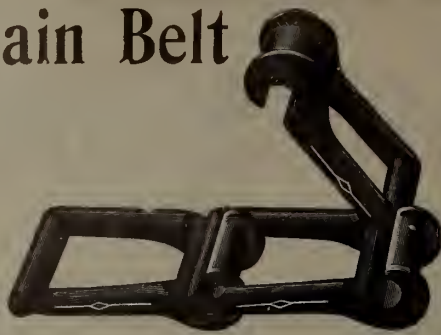

William R. Perrin & Company
Limited

TORONTO, CANADA.

FRANK DENTON, K. C. HERBERT L. DUNN,
W. MULOCK BOULTBEE.

DENTON, DUNN & BOULTBEE
Barristers, Solicitors, Notaries, etc.
National Trust Chambers. TORONTO

OILS

Manufacturers High-grade Cylinder, Ma-
chine and Sawmill Oils.

Calypsol Grease

for Sawmill Purposes a Specialty.
Our products are made from finest Penn-
sylvania stocks.

We solicit your correspondence.

St. John St. Commercial
MONTREAL. Oil Co.,
Offices and Works :
Manchester, Eng. Hamilton, Ont.
Hamburg, Germany.
Newark, N. J.
Chicago, Ill.

SHERMAN'S FLOORING MACHINES

PATENTED

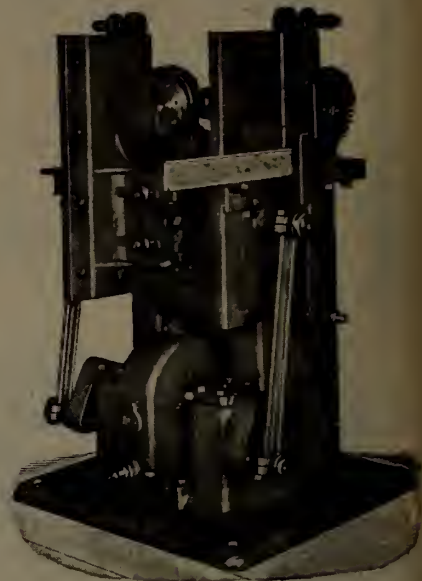

Above cut shows our End Matcher, the best
machine in the market for end matching floor-
ing strips. They do rapid and accurate work,
and are durable—therefore used by leading
flooring manufacturers. Make your flooring
profitable by end matching it.

We Make the

**SHERMAN SIDE
BORING MACHINES**

and the

**SHERMAN FACE
BORING MACHINES**

To bore flooring while it is being run on the
flooring machine. Write for circular and list
of users.

W. S. SHERMAN CO.

1150 Holton St., Milwaukee, Wis



Sole Canadian Agents - Prices Reduced
WATEROUS, BRANTFORD, CANADA

Please mention this paper when corres-
ponding with advertisers.

This is the Band Wheel Grinder

We have been talking about

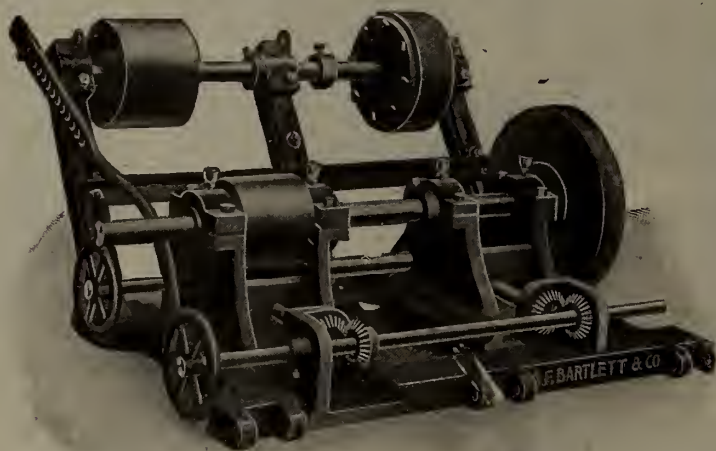

IT PAYS FOR ITSELF IN THREE TIMES USING

For full description and price
write to the manufacturers

A. F. BARTLETT & CO.

Saginaw, Mich.

WOODWORKERS SAY

"The convenience to the Sawyer and
the saving in lumber make the
STANDARD AUTOMATIC SAW GAUGE
an article of much merit."



WRITE TO
SPECIALTY MFG. CO.
DETROIT
Mich.

OXFORD FOUNDRY AND MACHINE CO. OXFORD, N. S.

OUR SPECIALTY IS

SAW MILL MACHINERY

We Have Filled Orders from the Pacific
Coast of B. C. to Labrador. ❁ ❁ ❁

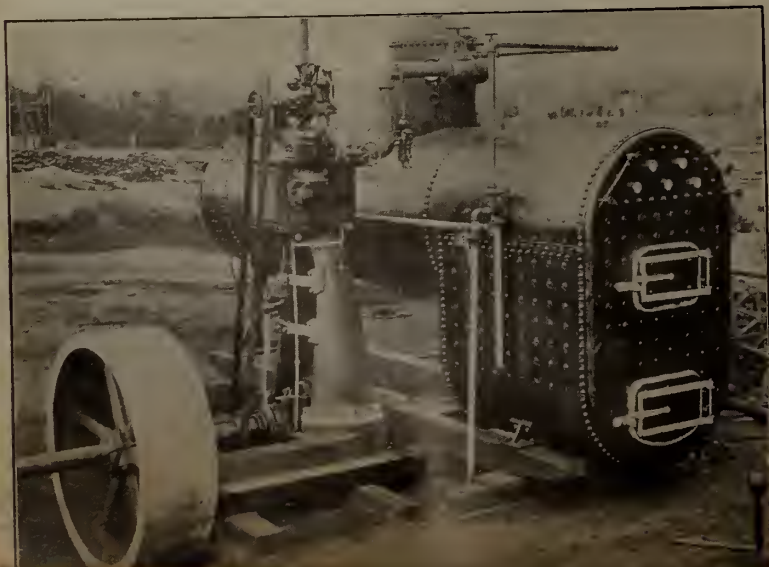

WRITE AND LET US GET ACQUAINTED

Do you lack steam ?

We can help you.

THE GORDON HOLLOW BLAST GRATE CO.

Established 1889.

GREENVILLE, MICHIGAN

Manufacturer of the following well-known articles :—

The Gordon Hollow Blast Grate—Gives as good results with wet, green or frozen sawdust or other refuse as a draft grate gives with dry wood. Adds from 25 to 50% to the effective steaming capacity of a boiler. Sold on approval.

The TOWER 2 and 3-saw Edgers, Improved—For mills cutting not to exceed 20,000 ft. in ten hours.

The TOWER EXTRA 3-saw Edgers—A larger and heavier edition of the TOWER Edger, for mills cutting up to 30,000 ft. in ten hours.

These are admittedly the best known edgers on the market to-day, and deservedly so. There are over 1,600 of them in daily use.



The TOWER One-man 2-saw Trimmer—With this trimmer one man can easily trim the output of a mill cutting up to 30,000 ft. in ten hours. There are two feeds.

The TOWER Variable Feed One-man 2-saw Trimmer—For mills cutting up to 50,000 ft. in ten hours. The only trimmer on the market with a variable feed.

The manner of shifting the saws on both of these trimmers saves time, steps and lumber.

SEND FOR CATALOGUE D.

RUBBER BELTING

For
Transmitting
Elevating
and
Conveying



Rubber
Hose
for
Water
Steam
Air
Suction
Fire
Protection

THE GUTTA PERCHA & RUBBER MFG. CO.
OF TORONTO, LIMITED.

TEMPORARY OFFICES: 15 EAST WELLINGTON STREET, TORONTO, CAN.

Branches: Montreal, Winnipeg.

Perfect Swing Shingle Mill

Fitted with our "Automatic Trip."

Best Swing Shingle Machine on the Market today for cutting Shingles, Headings, Etc. . .

It will pay you

to write for description and price before placing your order.

We also Manufacture a complete line of . . .

SAW MILL MACHINERY, ENGINES AND BOILERS

THE Owen Sound Iron Works Co. LIMITED

Owen Sound, Ont.

SEND FOR CATALOGUE

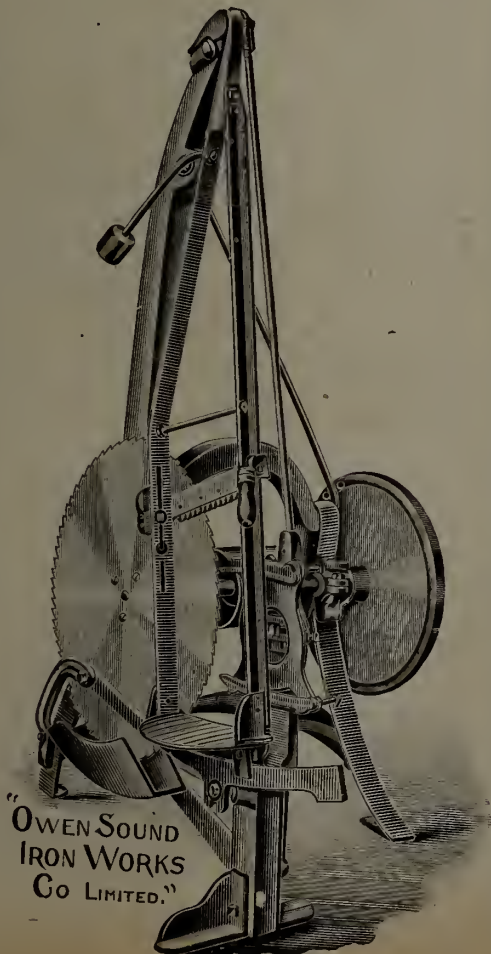

"OWEN SOUND IRON WORKS CO. LIMITED."

THE TWENTIETH CENTURY SAW

OVER 40,000 IN USE

BEWARE OF IMITATIONS



THE GENUINE IS MADE ONLY BY

R. HOE & CO.,

504-520 GRAND ST., NEW YORK, N.Y.

RAILS For Logging, Tramways, Switches, Etc.
YARD LOCOMOTIVES New and Second-Hand.
 John J. Gartshore
 83 Front St. West,
 (Opposite Queen's Hotel,) Toronto.

R. SPENCE & CO.
 Beech File Works.
 HAMILTON, ONT.
 FILE AND RASP MANUFACTURERS
 AND RE-CUTTERS
 And trial order solicited. Write for price list and terms.
 C. P. MOORE, PROPRIETOR.

TENTS, OIL CLOTHING, and **TARPAULINS,** HORSE and WAGON COVERS
 FOR LUMBERMEN'S USE A SPECIALTY.
 EVERYTHING IN CANVAS MANUFACTURED.
 The Montreal Tent, Awning and Tarpaulin Company,
 Send Prices on Application. 25 Youville Place, MONTREAL



The "Alligator" Steam Warping Tugs
 SIDE WHEELS OR TWIN SCREWS

The Twin Screws are arranged with flexible joint to raise up in crossing portage

MANUFACTURED BY

WEST & PEACHEY, - Simcoe, Ont.

Cables carried in stock for renewals

FOR THE CAMP TABLE

- | | |
|---------------------------------------|--------------|
| Mess Pork | Smoked Hams |
| Short Cut Pork | Roll Bacon |
| Plate Beef | Pure Lard |
| Dressed Fresh Beef | Pork Sausage |
| Long Clear Bacon, Butter, Cheese, &c. | |

Write us for Special Prices on Car Load Lots.

THE PARK BLACKWELL CO., L'T'D
 PORK AND BEEF PACKERS
 TORONTO



New Century Refrigerator & Manufacturing Co., Limited
 Dundas, Ont., Can.

Our Business is Manufacturing

HARDWOOD VENEER . . DOORS
 With Built Up Bodies

These Doors are guaranteed not to warp or twist and are superior in construction and finish to any other Door on the market.

Send for Illustrated Catalogue and Prices.

Special attention given to Architects' Designs of Doors and Trims.

AGENTS WANTED EVERYWHERE. ADDRESS DOOR DEPARTMENT

Normandin Cement Block Machine



There's **Money** in the Block Business

Experience not Necessary for Success.

The **NORMANDIN** machine does the work.

THINK IT OVER, and decide quickly to start a Block Yard in your town. Others are making a success of the business—you can too. Write to-day for particulars of the **NORMANDIN MACHINE**. Hundreds of them in use daily. Hand labor and a little common sense will turn out a perfect stone on the **NORMANDIN**. This is the machine that took the Highest Award at St. Louis Fair, 1904. The United States Government Engineers will buy nothing but the best. They bought and are using the **NORMANDIN**—IT MUST be right.

The **NORMANDIN** complete equipment comprises over 200 parts and weighs 3,000 lbs.

SOLE AGENTS FOR CANADA

The Cement Block Building Co., Limited
 Winnipeg Vancouver Toronto
 Largest Cement Block Manufacturers in Canada

1,000 Mershon Band Resaws

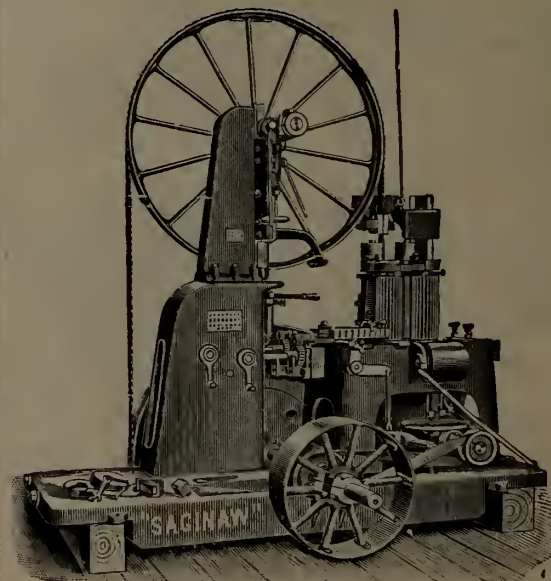

IN DAILY USE

BUY DIRECT AND GET

— THE —
GENUINE

W.B. MERSON & CO.
 Saginaw Mich., — U. S. A.

**NATURAL DRAFT
MOIST AIR . . . DRY KILNS**
LUMBER TRUCKS and
TRANSFER CARS

Write for prices and particulars of the most simple and efficient Natural Draft Dryer on the market. Testimonials and list of users sent on application. Every square inch of heating surface is utilized to the uttermost and perfect ventilation and circulation is obtained by a very simple arrangement of ducts. Write for particulars to

**SHELDON & SHELDON,
GALT, ONT.**

FORMERLY McEACHREN HEATING & VENTILATING CO.

A Bigger Cut of Lumber



for the same expenditure of power can be had by using

MIDLAND BEARING METAL

owing to the fact that it is self lubricant to a greater degree than any other metal, and you will lose no time with hot boxes. Then it will cost you **Only 15 cents per pound**, which makes it a

MONEY SAVING PROPOSITION

A TRIAL ORDER WILL CONVINCe YOU.

Georgian Bay Engineering Works
Midland, Ont.

**The Dry Kiln That's Nearest
Perfection**

In adaptability to successfully meet the special requirements of every variety of lumber—

In maximum capacity of satisfactory drying—

In permanence of construction and exclusive features of superiority—

In simplicity and ease of operation—

IS

THE STANDARD DRY KILN

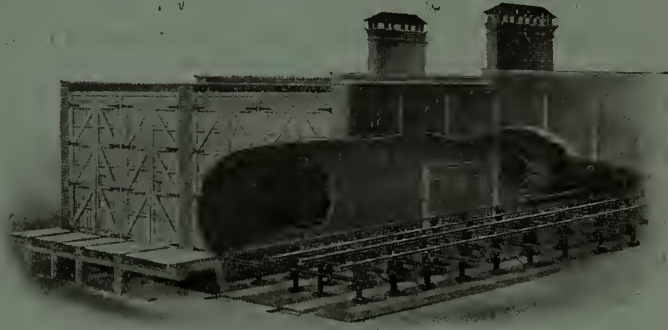

Our Catalogue "D" goes into details on all these points; and contains expressions of satisfaction from saw and planing mill people IN YOUR VICINITY who will be pleased to correspond with you directly regarding the results they are obtaining from The Standard Moist Air Drying System.

Tell us to send you the catalogue—and then you write them.

The Standard Dry Kiln Co.
Indianapolis, Indiana



FOR _____
DRY KILNS

that will season lumber of all kinds and under all conditions, whether partially air-seasoned or green from the log, in shortest time and at least cost, entirely free from checking, warping or case hardening,

Write to—

McEACHREN HEATING & VENTILATING COMPANY, GALT, CANADA.

**"Do To-day's Work This Morning---
Tomorrow's This Afternoon."**

Equip your Shaping Machines with OUR

SOLID STEEL SHAKER CUTTERS

They CUT FREE and EASY in all kinds of stock, and RETAIN THEIR ORIGINAL FORM UNTIL WORN OUT. "Always Ready for Use."

Send for Catalogue.

FURITURE CITY TOOL CO.

Makers of WOOD WORKING TOOLS

189 Campau Street.

Grand Rapids, Mich., U. S. A.



USE "THE KING" We have 40 years' experience in the

ANTI



FRIC TION

ience in the
MANIPULATION
of Metals.

BABBITT METAL

Bronze and Lead Castings a
Specialty for Pulp Mills.

THE JAMES ROBERTSON COMPANY, LIMITED

Montreal, Que. Toronto, Ont. St. John, N.B. Winnipeg, Man.

Steam, Power
and
Centrifugal Pumps,
Condensers,
Travelling Cranes.



Stock Carried in:

HALIFAX,
MONTREAL,
HAMILTON,
WINNIPEG,
VANCOUVER.

THE SMART-TURNER MACHINE CO., LIMITED
HAMILTON, ONTARIO

SEND FOR **H. W. PETRIE'S**
MONTHLY STOCK LIST
NEW & 2ND MACHINERY
TORONTO, CANADA

DO YOU USE
Number **128** Tacks

ACTUAL SIZE

We make them, also Steel Log
Hammers and Stamps, Brass
Stencils and Stencil Inks.
HAMILTON STAMP & STENCIL WORKS,
HAMILTON, ONT.



CRESCENT MACHINERY

Quality is all right.
So's the price.

Band Saws
Jointers
Saw Tables

Very low price on
BAND SAW BLADES

Catalogue tells the rest.

H. W. PETRIE

Dept. C. M.

TORONTO, ONT.



Rice Lewis & Son,

Dealers in _____ LIMITED

BAR IRON AND STEEL

BOOM AND LOGGING **CHAINS** MADE TO ORDER

TORONTO

Write for
Prices.

THE
LEATHER BELT
THAT'S
KNOWN
OUR
"EXTRA"



MONTREAL
WINNIPEG

TORONTO
VANCOUVER

PINK LUMBERING TOOLS

The Standard Tools

In Every Province of the Dominion, New Zealand, Australia, Etc.



Pink Round Bill Peavey, Handles in Split Maple

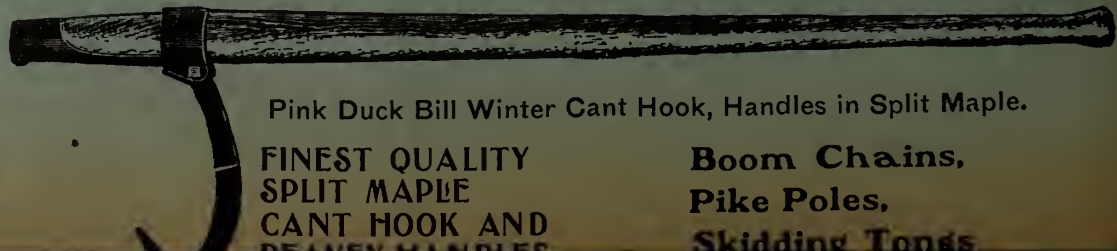

Pink Duck Bill Winter Cant Hook, Handles in Split Maple.

**FINEST QUALITY
SPLIT MAPLE
CANT HOOK AND
PEAVEY HANDLES**

**Boom Chains,
Pike Poles,
Skidding Tongs**

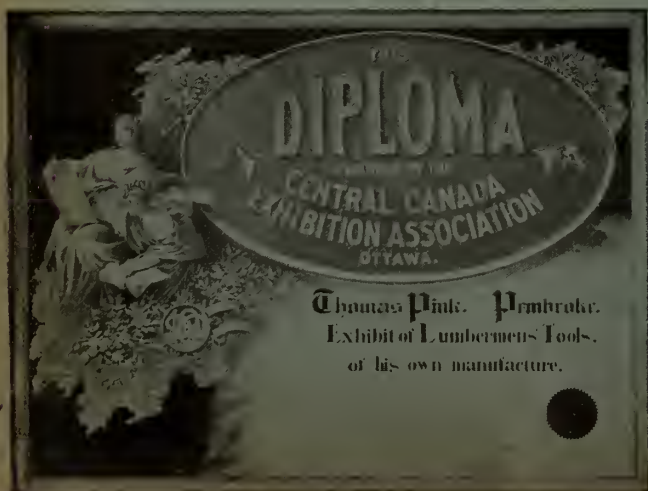

Thomas Pink, Pembroke.
Exhibit of Lumbermen's Tools,
of his own manufacture.

THOMAS PINK

THE CANADA LUMBERMAN AND WOOD-WORKER

VOLUME XXV. }
NUMBER 3.

TORONTO, MONTREAL, WINNIPEG, CANADA, MARCH, 1905

{ TERMS, \$1.00 PER YEAR
Single Copies, 10 Cents.

FAT. OSCILLATING BOB SLED KNEE

Hauls 25 per cent. easier, and wears longer, and is lighter than all others.

THOMPSON MFG. CO., Ltd.,
Grand Bay, N. B.

JNO. S. FIELDING, C. E.

DAMS

Room 2, 15 Toronto Street - TORONTO

WIRE ROPE



Special Alligator Ropes any lengths, fitted with proper attachments

Saw Carriage Ropes
Haulage Ropes
Elevator Ropes
Smoke stack stays, &c.
Standard and Lang's Patent Lay

THE B. GREENING WIRE COMPANY, LIMITED

HAMILTON, ONT.

MONTREAL, QUE



The Ottawa Saw Co. LIMITED

Middle Street, OTTAWA, ONT.

Sandvik Swedish Steel

Band, Gang and Circular Saws
P. M. FEENY, Manager.

Leather Belting

It isn't the price, it's what you get for the price, that counts.

J. L. GOODHUE & CO.,
DANVILLE, QUEBEC.

D. K. McLaren

GENUINE

Oak Belting

MILL SUPPLIES

751 Craig St., Montreal.

132 Bay St., Toronto.

WOODS LIMITED

Wholesale Manufacturers of . .

LUMBERMEN'S AND CONTRACTORS' SUPPLIES

INCLUDING

Tents, Flags, Awnings, Tarpaulins, Clothing, Overalls, Shirts, Mitts, Underwear, Blankets, Axes, Moccasins, Woods Celebrated Eider Down Sleeping Bags

WOODS BUILDING - OTTAWA, CAN.



DICK'S BELTINGS



Never is affected by wetness, and does not stretch

Excels in Transmission Power

Always Uniform.

LARGE STOCK ON HAND

WRITE TO SOLE AGENTS:

J. S. YOUNG, 413 St. Paul Street MONTREAL

Complete Stock for Prompt Delivery

WIRE ROPE

W. H. C. MUSSEN & CO. MONTREAL

THE E. R. BURNS SAW CO.

TORONTO, ONT.

MANUFACTURERS OF HIGH-GRADE

Circular and Long Saws

UNEXCELLED

SHINGLE SAWS



The Wm. Hamilton Mfg. Co., Limited

Builders of a Complete Line of

SAW MILL MACHINERY

The

STEAM TENSION

BAND MILL FOR SINGLE OR
DOUBLE CUTTING



Before the introduction of the Steam Tension Mill, it had been the universal custom to maintain the strain on the saw by the use of some system of levers and weights.

It is well-known that the action of a weight--especially one as heavy as must be used in the tension mechanism of a band mill--is necessarily slow on account of its inertia.

Every practical mill man will admit that, in order to get the best results in sawing, the tension device should be very sensitive and capable of responding instantly to the varying demands of the work. As it is manifestly impossible for any form of weight tension to meet these requirements, we have

substituted for the weight a direct acting steam cylinder, so arranged that the strain on the saw can be varied at will from 3,500 pounds up to any required amount.

It will be evident to anyone familiar with the use of steam that the action of this saw straining device must be instantaneous, and consequently the saw will always be kept in proper tension to do its best work

We have a booklet giving a great many more points of advantage possessed by this mill—write Dept. L for it.

Branch Office :
Vancouver, B. C.

Head Office and Works :
Peterborough, Ont.

THE

MAPLE LEAF SAW WORKS



Shurly & Dietrich GALT, ONT.

Manufacturers of

**CIRCULAR SAWS
GANG SAWS
MILL SAWS
BAND SAWS
CROSS-CUT SAWS**

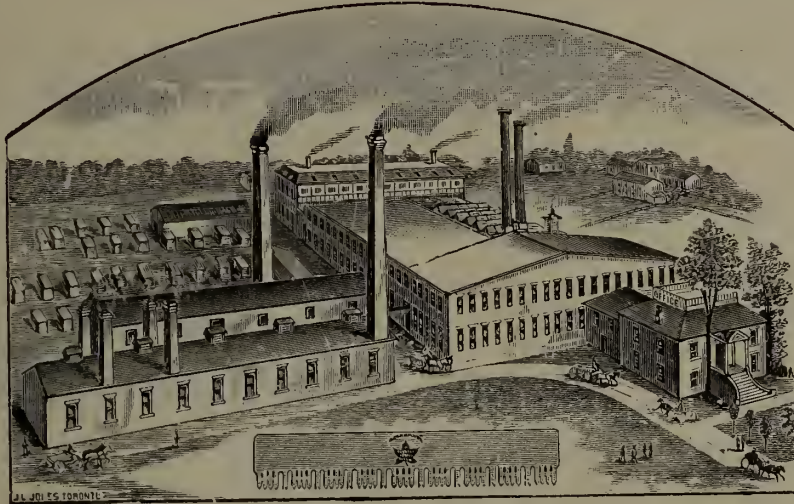

Manufacturers of

**HAND SAWS
BUCK SAWS
PLASTERING TROWELS
BUTCHER SAWS
STRAW KNIVES, &c.**

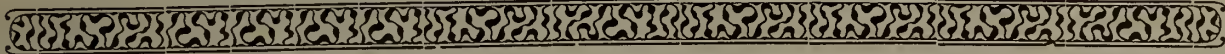

GROUND THIN ON BACK

Save Labor Save Gumming
Save Time Save Files

This Saw Stands Without a Rival

AND IS THE

FASTEST CUTTING SAW IN THE WORLD!

Its Superiority consists in its Excellent Temper. It is made of "Razor Steel," which is the finest ever used in the manufacture of Saws. We have the sole control of this steel. It is tempered by our secret process, which process gives a keener cutting edge and a toughness to the steel which no other process can approach.

Maple Leaf Saw Set

MANUFACTURED BY
SHURLY & DIETRICH, Galt, Ont.

Directions.—Place the set on the point of tooth, as shown in the accompanying cut, and strike a very light blow with a tack hammer. If you require more set, file the tooth with more level.
If you follow directions you cannot make a mistake. Be sure and not strike too hard a blow, and it will set the hardest saw. On receipt of 40 cents we will send one by mail.

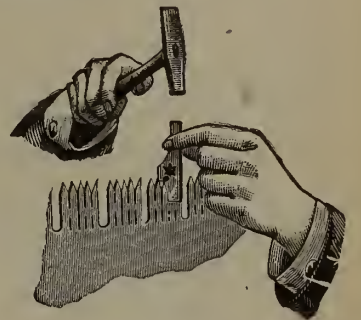

We are the only manufacturers in the world who export Saws in large quantities to the United States.

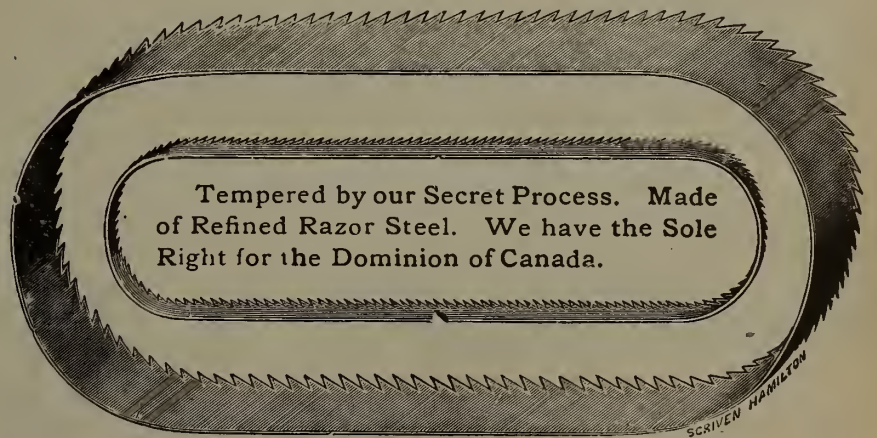

We Manufacture

HIGH GRADE BAND SAWS

Of All Widths and Lengths.

These Saws are made of Refined Swedish Steel imported direct, and tempered by our Secret Process; for Fine Finish and Temper are not excelled.

BRITISH COUMBIA LUMBER AND SHINGLE MANUFACTURERS

The Canadian Pacific Lumber Co., Limited
PORT MOODY, B. C.

Manufacturers and Wholesale Dealers in All Kinds of **B. C. LUMBER, LATH, MOULDINGS, ETC.**

The Largest Shed and Dry Kiln Capacity of any Mill in British Columbia. Special Attention Given to Orders from Manitoba and the Territories. † Long Distance Telephone Connection. † Address the Company at Port Moody or **BYRNES & CUDDY, Selling Agents, WINNIPEG**

CLOVERDALE MILLING CO., CLOVERDALE, B. C.

== **Red Cedar Shingles** ==

OUR SPECIALTY

SECOND TO NONE

CORRESPONDENCE SOLICITED

PETER LUND, Managing Director.

J. BRECKENRIDGE, President.

MANUFACTURERS OF ALL KINDS OF

Grows Nest Pass Lumber Co., Limited
WARDNER, B. C.



BUILDING MATERIAL

Capacity 150,000 Feet Per Day.

THE KING LUMBER MILLS, LIMITED, GRANBROOK, B. C.

Manufacturers of **Building Materials**

And All Kinds of DIMENSIONS, FLOORING, CEILING and BASE and CASE MOULDINGS

Columbia River Lumber Company, Limited

HEAD OFFICE AT GOLDEN, B. C.

Largest Capacity in Mountains

MILLS AT { GOLDEN, B. C.
BEAVER, B. C.
KAULT, B. C.
CARLIN, B. C.

ROUGH AND DRESSED

LUMBER

FIR, SPRUCE
CEDAR AND PINE

LATH

Telephone Poles, Piling, Etc., a Specialty.

The Fernie Lumber Co., Limited, Fernie, B. C.

MANUFACTURERS OF AND DEALERS IN ALL KINDS OF

ROUGH AND DRESSED LUMBER

Dimension and Bridge Timber a Specialty.

Moulding in Stock or Made to Order.

H. CAMERON, Manager.

DONALD GRANT, President.

Moyie Lumber & Milling Co., Limited, Moyie, B. C.

Manufacturers and Dealers in All Kinds of

FLOORING, CEILING, SIDING, SHIP LAP, COMMON BOARDS, DIMENSIONS AND LATH

Specialty: **MOUNTAIN TAMARAC**

JOS. GENELLE, Manager.

J. G. BILLINGS, Secretary.

THE YALE-COLUMBIA LUMBER COMPANY, LIMITED

Head Office: NAKUSP, B. C.

Mills at Nakusp, Westley and Cascade, B. C.

MANUFACTURERS OF

DEALERS IN

All Kinds Rough and Dressed Lumber, Mouldings, Lath, Etc.

||| Cedar and Fir Piles, Telephone and Telegraph Poles, Fence Posts, Etc.

BRITISH COLUMBIA LUMBER AND SHINGLE MANUFACTURERS

Canadian Timber & Saw Mills, Limited, Trout Lake, B. C.

MANUFACTURERS OF ALL KINDS OF

ROUGH AND DRESSED LUMBER

Specialties: Clear Cedar and High Grade Cedar Shingles

Send on Your Orders to the Above Company.

Prompt Shipments Guaranteed.

Capacity: 60,000 feet per day; 80,000 Shingles.



THE PIGEON RIVER LUMBER COMPANY PORT ARTHUR, ONT.

MANUFACTURERS OF

Band Sawed White Pine Lumber, Lath, Pine and Cedar Shngles.

are operating their extensive plant night and day, to keep abreast with orders.

THERE IS A BECAUSE—

A trial order will tell you why.

Winnipeg Representative,

D. J. McDONALD, Clarendon Hotel.

J. A. SAYWARD

MANUFACTURER OF AND DEALER IN

Cedar and Spruce Lumber

Shingles, Lath, Spars, Etc.

ORDERS CAREFULLY EXECUTED
PROMPT SHIPMENTS

VICTORIA, B. C.

THE BRITISH COLUMBIA MILLS, TIMBER & TRADING COMPANY

Head Office: VANCOUVER, B. C.

Winnipeg Office: Merchants Bank Building P. O. Box 235

MANUFACTURERS OF

BRITISH COLUMBIA FIR, CEDAR and SPRUCE—both Rough and Dressed. Sash, Doors, Mouldings Lath and the Highest Grades

“ROYAL CITY BRAND”

RED CEDAR SHINGLES

DOUGLAS FIR TIMBER

All Widths and Thicknesses up to 120 feet in Length Supplied on the Shortest Possible Notice.

HASTINGS SAW MILL - VANCOUVER, B. C.
ROYAL CITY SAW MILL, VANCOUVER, B. C.

OWNERS AND OPERATORS OF
ROYAL CITY SAW MILL, NEW WESTMINSTER, B. C.
MOODYVILLE SAW MILL - BURRARD INLET, B. C.

Total Capacity, 400,000 Feet of Sawn Lumber per Working Day of Ten Hours.

The Ladysmith Lumber Co., Limited

LADYSMITH, B. C.

Manufacturers of

LUMBER, LATH, SHINGLES,
MOULDINGS, ETC.

SPECIALTY: The best Cedar Shingles manufactured on the Coast.

FRESH WATER FIR LATH ALWAYS IN STOCK.

Capacity of Shingle Mill, 100,000 per day of 10 hours.

Correspondence Solicited

BRITISH COLUMBIA LUMBER AND SHINGLE MANUFACTURERS

North Star Lumber Co., Limited, Cranbrook, B. C.

Manufacturers of **PINE, FIR and TAMARAC LUMBER**

Specialty: Heavy Timber and Piling

D. & J. HADDEN, CLOVERDALE, B.C.

MANUFACTURERS AND DEALERS IN THE HIGHEST GRADE

LUMBER AND RED CEDAR SHINGLES

Send your orders to the above firm, who can supply you with shingles that cannot be beaten for quality and prices.

Agent for Ontario: Woodstock Lumber and Manufacturing Co., Woodstock, Ont.

BIG BEND LUMBER CO., LIMITED, ARROWHEAD, B. C.

Manufacturers of **Lumber, Lath and Shingles**

CORRESPONDENCE SOLICITED

EAST KOOTENAY LUMBER CO., LIMITED

Capacity 150,000 feet per day.

Saw and Planing Mills at RYAN, CRANBROOK and JAFFRAY.

— WE MANUFACTURE —

**TAMARAC
PINE and FIR**

FOR THE NORTH-WEST TRADE

Send us your orders if you want dry stock.

Head Office: **CRANBROOK, B. C.**

D. B. GRANT.

T. W. KERR

DELTA SAW MILL CO.

MANUFACTURERS OF

Rough & Dressed Lumber, Lath, Shingles,
Fence Pickets, Doors, Sash, Mouldings,
Salmon and Fruit Boxes, and Round Tanks

Correspondence Solicited. - - LADNER, B. C.

Please mention this paper when corresponding with advertisers

Galt Machine Knife Works



MACHINE KNIVES OF EVERY DESCRIPTION
FOR **Woodworking Machines**
... Send for Price List ...
The Peter Hay Knife Co., Limited - Galt, Ont.

Mouldings **Shingles**

**VICTORIA LUMBER AND
MANUFACTURING CO., LIMITED**

MILLS AT CHEMAINUS, B. C.

FIR AND CEDAR LUMBER

of all descriptions, in straight or mixed cars.

We can supply large and long timbers, but
don't care to ship anything over 40x40x140
feet long. : : : : :

Prompt Shipments
Good Quality and Manufacture
Long Lived Timber

ADDRESS—

CHEMAINUS, B. C.

**SCRIBNER'S
LUMBER and
LOG BOOK**

A handy book for Lumbermen. Gives
Correct Measurements of Scantlings, Boards
and Planks; Cubical Contents of Square and
Round Timber; Doyle's Rules and much other
practical information.

PRICE, 35 CENTS

**THE
CANADA
LUMBERMAN**
TORONTO, ONT.

Moreau's Pulpwood Barking Machine

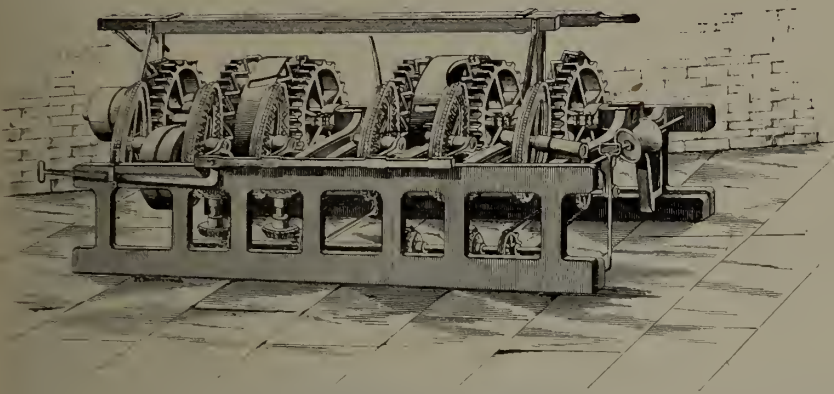

WEIGHT 4,200 LBS.

Latest and best Pulpwood Barking Machine. Requires about 7 h. p. to drive it full speed in work and one man can handle it and bark 22 to 30 cords of 4 foot wood per day according to average size of wood.

Wood is fed end on and any size from 3 to 24 inches, as the wood runs without loss of time between sticks. No long shavings and greatest economy in wood. Machines may be seen working any time. Write me for particulars.

R. S. P. SMYTH - QUEBEC, QUE.

Sole Agent for Canada

*P. O. Box 236
L. D. Phone 386*

THE E. LONG MANUFACTURING CO., ORILLIA, ONT.

THESE SAW CARRIAGES ARE MADE OF CAST STEEL, AND OPEN 36 TO 54 IN. FROM SAW.

We build Double Edgers, Steam Feeds, Log Jacks, Live Rolls, Trimmers, Slab Slashers, Steam Niggers.

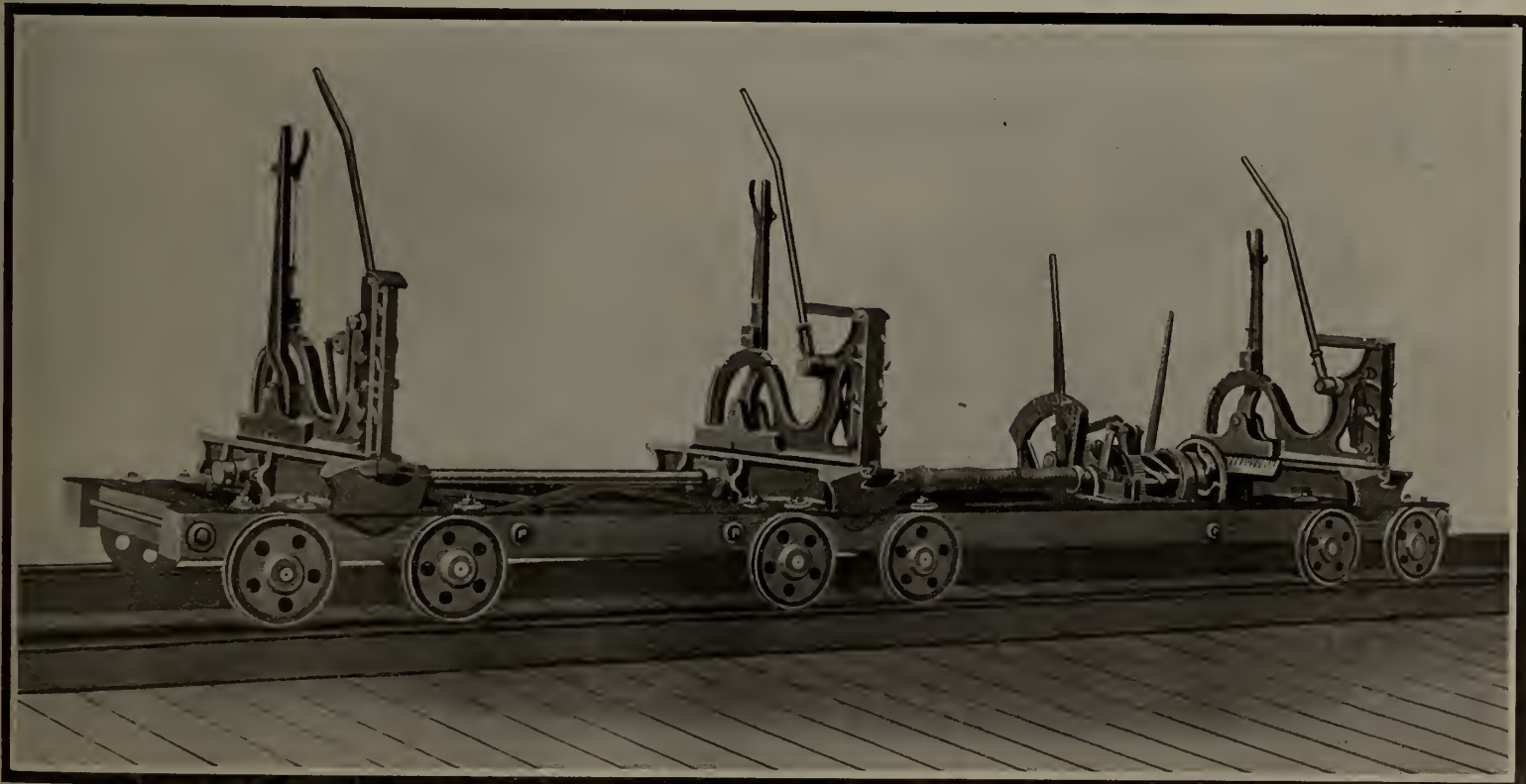

COMPLETE LINE OF SAW AND SHINGLE MILL MACHINERY
WRITE FOR CATALOGUE AND PRICES

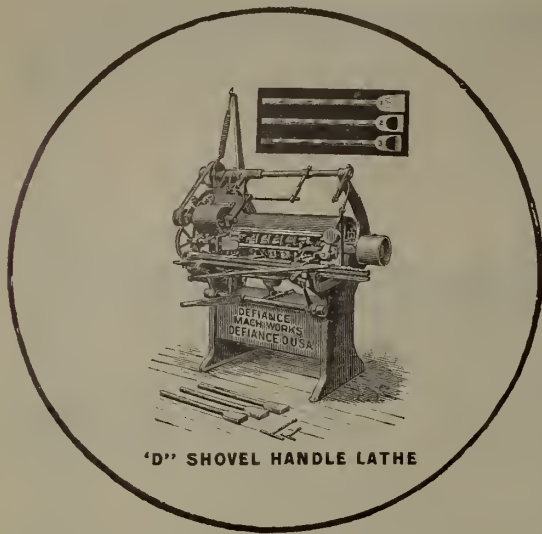

"DEFIANCE"
Wood--Working Machinery

For Manufacturing
**HUBS, SPOKES, WHEELS, WAGONS,
 CARRIAGES, RIMS, SHAFTS, POLES,
 NECK-YOKES, SINGLE TREES, BARREL
 HOOPS.**

Handles of Every Kind, insulated Pins, Spools,
 Bobbins, Oval Wood Dishes, and General Wood-
 Work.

Invented and Built by

THE DEFIANCE MACHINE WORKS,
 Defiance, Ohio, U. S. A.



THE SCHAAKE MACHINE WORKS

NEW WESTMINSTER, B. C.

Builders of a Complete Equipment of

Saw^{and} Shingle Mill Machinery

SOLE MANUFACTURERS OF

Johnson's Improved Upright Shingle Machines

Our Celebrated

Rotary Cutting Veneer Machines

made in over sixty sizes, have stood the test and proved equal to any proposition to reduce logs into thin lumber and veneers.



The product is high grade.
 The output is great.
 The cost of operating and maintenance is reduced to a minimum.
 Quite a combination, is it not?

Timber and mill owners should get in early.
 Buy a Coe Veneer Cutting and Drying outfit and prepare to
 supply thin lumber and veneers which have a healthy growing
 demand. More money in it than sawing your logs into lumber.

WRITE US.

THE COE MANUFACTURING COMPANY, Painesville, Ohio, U. S. A.

Established 1852.

Largest Builders of Veneer Cutting Machinery in the world.

JOSHUA OLDHAM & SONS

ESTABLISHED 1870.

NEW YORK SAW WORKS

The Oldham Saws for Sawmills

BRIDGE OVER THE CARES, AND LEAVE



PLEASANT REFLECTIONS OF
SUCCESSFUL LUMBER PRODUCTION

JOSHUA OLDHAM & SONS

NEW YORK SAW WORKS

BROOKLYN BOROUGH
NEW YORK

The DODGE Split Friction Clutch Pulley

Perfect Balance
Easy to Adjust
Liberal Clearance
Excellent Lubrication
Repairs Easily Made

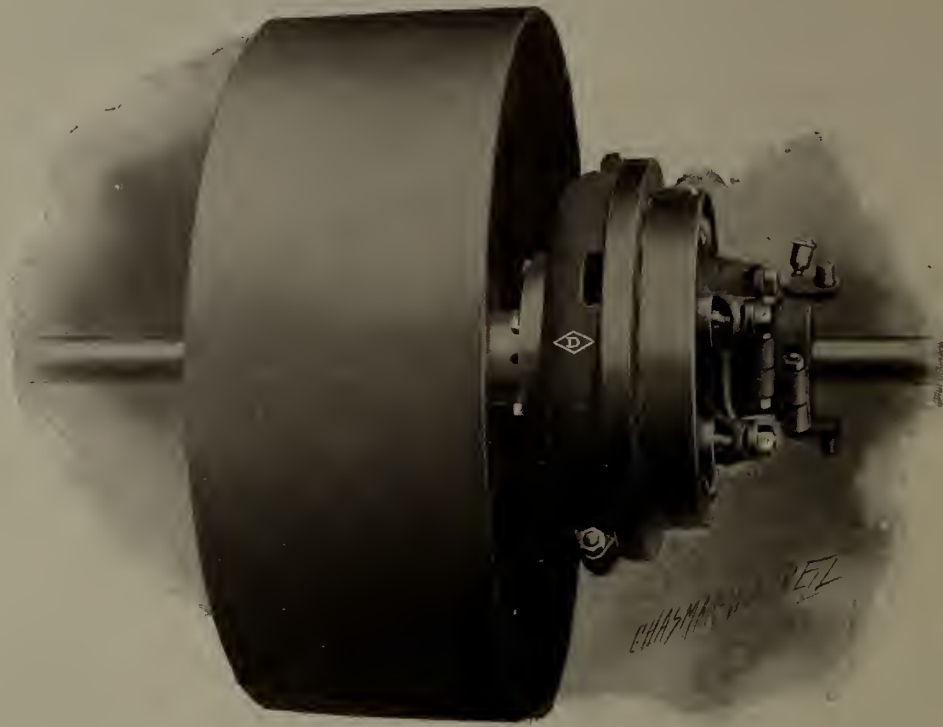

Simplicity
Positive Friction
The Split Feature
Low First Cost
Detachable Sleeve

In use in many of the representative Saw and Planing Mills from coast to coast.
Write us about Friction Clutch Pulleys and Couplings.

SOLE MAKERS :

DODGE MANUFACTURING CO.

TORONTO - MONTREAL

THE TRIUMPH TURBINE



Is the most powerful wheel on the market to-day. A glance at this cut of the centre shows that the buckets are designed to secure the **maximum of speed** with **great power** and a **free discharge**. Mr. E. S. Edmondson, of Oshawa, writes as follows under date of November 16th, 1903, regarding a 26 inch Vertical Triumph Wheel :

"The Wheel is strictly first-class in every particular, and after a careful and thorough test I am prepared to say that I believe it is the best wheel in the market for Electrical purposes. It has high speed, large power, high efficiency at part gate, and has practically no leakage. I am more than pleased with the thorough and workmanlike setting you gave me throughout."

For horizontal settings in large Pulp Mills, Cement Mills or Electric Power Developments this Wheel has no equal. We invite your enquiries. Large catalogue to be had for the asking.

We are always glad to submit estimates and prices on **Improved Vulcan and Leffel Turbines, Improved Lane Circular Saw Mills, Edgers, Trimmers, Slashers, Shingle Machines, Lath Machines** and all machinery of this kind.

MADISON WILLIAMS

Successor to Paxton, Tate & Company
PORT PERRY, ONT.

Manitoba Iron Works
Western Selling Agents
Winnipeg, Man.

H. E. PLANT, Agent
Cor. Common and Nazareth Streets
Montreal, Que.

CLASSIFIED INDEX OF ADVERTISERS

AXES
 Dundas Axe Works. 12

ALLIGATOR TUGS
 West & Peachey. 35

BELTING
 Dominion Belting Co. 37
 Fairbanks Co. 31
 Gutta Percha & Rubber Mfg. Co. 41
 Goodhue & Co., J. L. 1
 McLaren, D. K. 1
 McLaren Belting Co., J. C. 44
 Sadler & Haworth. 27
 Waterous Engine Works Co. 37
 Wilby, P. H. 12
 Young, J. S. 1

BUILDING BLOCKS
 Cement Building Block Co. 30

BABBITT METALS
 Syracuse Smelting Works. 22

BOILERS
 Canada Foundry Co., Limited. 12
 Dymont Foundry Co. 36

DOORS
 New Century Refrigerator & Mfg. Co. 11

DRY KILNS
 Andrews Co., The A. H. 42
 McEachren Heating & Ventilating Co. 43
 Sheldon & Sheldon. 43
 Standard Dry Kiln Co. 43

ELEVATING AND TRANSMITTING MACHINERY
 Buhl Malleable Co. 12
 Dodge Manufacturing Co. 10
 Perrin & Co., R. 47

EMERY WHEELS
 Hart Corundum Wheel Co., Limited. . 24

ENGINES AND LOCOMOTIVES
 Dymont Foundry Co. 36
 Gartshore, John J. 11
 Owen Sound Iron Works. 41
 Robb Engineering Co. 33

EDGERS
 Gordon Hollow Blast Grate Co. 35

GRATES
 Gordon Hollow Blast Grate Co. 35

LUMBERMEN'S SUPPLIES
 Johnson, A. H. 37
 Montreal Tent, Awning & Tarpaulin Co.
 Merchants Rubber Company. 30
 Park, Blackwell Co. 30
 Rice Lewis & Sons, Limited. 44
 Thompson Mfg. Co. 1
 Woods, Limited. 1

LUMBER AND SHINGLE MANUFACTURERS
 Big Bend Lumber Co. 6
 B. C. Mills, Timber & Trading Co. . . . 5
 Canadian Pacific Lumber Co. 4
 Cloverdale Milling Co. 4
 Crows Nest Pass Lumber Co. 4
 Columbia River Lumber Co. 4
 Delta Saw Mill Co. 6
 East Kootenay Lumber Co. 6
 Fernie Lumber Co. 4
 Hadden, D. & J. 6
 King Lumber Mills. 4
 Ladysmith Lumber Co. 5
 Moyie Lumber & Milling Co. 4
 North Star Lumber Co. 6
 Pigeon River Lumber Co. 5
 Sayward, J. A. 5
 Victoria Lumber & Mfg. Co. 6
 Yale-Columbia Lumber Co. 4

LUMBERMEN'S TOOLS
 Baldwin, Tuthill & Bolton. 42
 Burton Saw Co., A. J. 39
 Hamilton Stamp and Stencil Works. . . 44
 Hay Knife Co., Peter. 6
 Pink, Thomas 44

MISCELLANEOUS
 Alexander Engraving Co. 1
 Bradstreets. 11
 Canadian Office & School Furniture Co. 11
 Denton, Dunn & Boulton, Barristers. 40
 Fielding, J. S., Consulting Engineer. . 1
 Glenyards Fire Clay Co. 33
 Georgian Bay Engineering Works—
 Grinders. 43
 Huther Bros.—Dado Heads. 44
 International Correspondence School. . 39
 Lumber Mutual Fire Insurance Co. . . . 31
 McFarlane-Neill Mfg. Co.—Cant Dogs. 33
 Metallic Roofing Co.—Corrugated Iron 26
 Spence & Co., R.—Files and R tsps. . 11

Scribner's Lumber & Log Book. 12
 Toledo Fire Insurance Co. 29
 Vogel, C. H.—Pulp Mill Engineer. . . . 23

OILS
 Commercial Oil Co. 40
 Canadian Oil Co. 22
 Queen City Oil Co. 11

PROVISIONS
 Clark, Wm. 31
 Eckardt & Co., H.P. 26

PORTABLE SAW MILLS
 Drake, F. J. 36
 Oxford Foundry & Machine Co. 40
 Owen Sound Iron Works. 41

PLANERS AND MATCHERS
 Clark & Demill 42

PULLEYS
 Dodge Manufacturing Co. 10

PACKING AND PIPE COVERING
 Garlock Packing Co. 12
 Purvis Co., E. L. 33

ROPE
 Canadian Cordage Co. 31
 Consumers Cordage Co. 32
 Dominion Wire Rope Co. 12
 Greeting Wire Co., B. 1
 Mussen & Co., W. H. C. 1

RE-SAWS
 Cowan & Co. 31

SAW SWAGES
 Crowell, D. J. 35
 Hanchett Swage Works. 25

SAW GAUCES
 Specialty Mfg. Co. 40

STEAM BOILERS
 Canada Foundry Co. 12
 Owen Sound Iron Works. 41

SAWS
 Atkins & Co., E. C. 33
 Burns Saw Co., E. R. 1
 Buckeye Saw Mfg. Co. 22
 Hoe & Co., R. 41
 Oldham & Sons, Joshua. 9
 Shurley & Dietrich 3

SAW MILL MACHINERY
 Allis-Chalmers-Bullock 28
 Bartlett & Co., A. F. 40
 Dunbar & Sons, Alex. 42
 Furniture City Tool Co. 43
 Gordon Hollow Blast Grate Co. 35
 Hamilton Mfg. Co., Wm. 2
 Long Mfg. Co. 7
 Lloyd Mfg. Co. 35
 Mershon & Co., W. B. 30
 Mowry & Sons, B. R. 37
 Owen Sound Iron Works. 41
 Oxford Foundry & Machine Co. 40
 Petrie, H. W. 44
 Payette & Co., P. 31
 Schaae Machine Works 8
 Smart-Turner Machine Co. 44
 Waterous Engine Works Co. 34
 Williams, Madison. 10

SHINGLE MILL MACHINERY
 Dunbar & Sons, Alex. 42
 Drake, F. J. 36
 Long Mfg. Co., E. 7
 Owen Sound Iron Works Co. 41
 Schaae Machine Works 8
 Williams, Madison. 10

TURBINES
 Williams, Madison. 10

TRIMMERS
 Gordon Hollow Blast Grate Co. 35

WOODWORKING MACHINERY
 American Woodworking Machinery Co. 38
 Clark & Demill. 42
 Connell & Dengler Machine Co. 37
 Coe Mfg. Co., The. 8
 Cowan & Co., Limited. 32
 Dodge Manufacturing Co. 10
 Defiance Machine Works. 8
 Mitts & Merrill. 32
 Perkins & Co. 37
 Rogers Iron Mfg. Co. 39
 Sherman Co., W. S. 40
 Shimer & Sons, Samuel J. 39
 Waterous Engine Works Co. 34

The . . .

QUEEN CITY OIL CO.

LIMITED

Head Office: TORONTO.

HIGHEST GRADES OF

Refined Oils
 Lubrication Oils

AND ALL

Petroleum
 Products

CANADIAN OFFICE & SCHOOL FURNITURE CO. LIMITED

PRESTON ONT.

FINE BANK OFFICE, COURT HOUSE & DRUG STORE FITTINGS.

OFFICE, SCHOOL, CHURCH & LODGE FURNITURE

SEND FOR CATALOGUE

ESTABLISHED 1849.

BRADSTREET'S

Capital and Surplus, \$1,500,000.

Offices Throughout the Civilized World.

Executive Offices: Nos. 346 and 348 Broadway, NEW YORK CITY, U.S.A.

THE BRADSTREET COMPANY gathers information that reflects the financial condition and the controlling circumstances of every seeker of mercantile credit. Its business may be defined as of the merchants, by the merchants, for the merchants. In procuring, verifying and promulgating information, no effort is spared, and no reasonable expense considered too great, but the results may justify its claim as an authority on all matters affecting commercial affairs and mercantile credit. Its offices and connections have been steadily extended, and it furnishes information concerning mercantile persons throughout the civilized world.

Subscriptions are based on the service furnished, and are available only by reputable wholesale, jobbing and manufacturing concerns, and by responsible and worthy financial, judiciary and business corporations. Specific terms may be obtained by address to the company or any of its offices. Correspondence invited.

THE BRADSTREET COMPANY.

OFFICES IN CANADA: Halifax N.S. Hamilton, Ont. London Ont.; Montreal, Que.; Ottawa, Ont.; Quebec, Que.; St. John, N. B. Toronto, Ont. Vancouver, B.C.; Winnipeg, Man.

THOS. C. IRVING,
 Gen. Man. Western Canada, Toronto

RAILS For Logging, Tramways, Switches, Etc. New and Second-Hand.

YARD LOCOMOTIVES

John J. Gartshore
 83 Front St. West,
 (Opposite Queen's Hotel,) Toronto.

R. SPENCE & CO.

Beech File Works.
 HAMILTON, ONT.
 FILE AND RASP MANUFACTURERS
 AND RE-CUTTERS

And trial order solicited. Write for price list and terms.

C. P. MOORE, PROPRIETOR.

New Century Refrigerator & Manufacturing Co., Limited

Dundas, Ont., Can.

Our Business is Manufacturing

HARDWOOD VENEER . . . DOORS

With Built Up Bodies

These Doors are guaranteed not to warp or twist and are superior in construction and finish to any other Door on the market.

Send for Illustrated Catalogue and Prices.

Special attention given to Architects' Designs of Doors and Trims.

AGENTS WANTED EVERYWHERE. ADDRESS DOOR DEPARTMENT

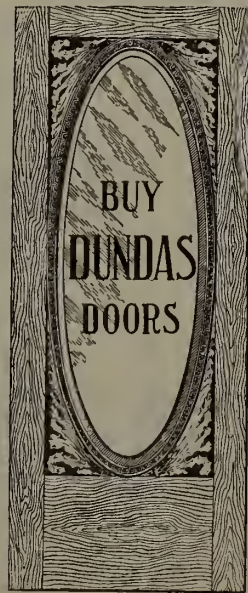

TEON BELTING



STEAM PROOF
WATER " "
HEAT " "
OIL " "
ACID " "

Stronger and Cheaper than
Leather.

LEATHER BELTING

CAMELS HAIR BELTING

CAPATA BELTING [BALATA TYPE]

LACE LEATHER, ETC.

Special Arrangements for Trial Felts.
Write for Price Lists and Discounts.

P. H. WILBY, 27 1/2 Front Street East, TORONTO

Phone Main 1930.

SOLE AGENT FOR CANADA.

Dundas Lumberman

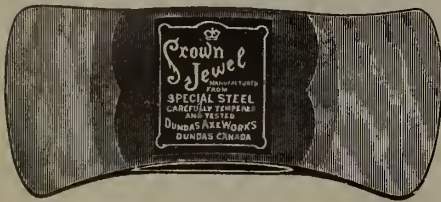

A New Axe tempered by a new process which enables us to submit to any lumberman three or more samples of Axes, all different degrees of hardness, and on a selection being made we will guarantee to furnish any number all exactly the same temper as sample chosen.

THE DUNDAS AXE WORKS

Dundas, Ont.

LARGE STOCK CARRIED & CUT TO ANY LENGTH
BLOCKS, CLIPS, TURNBUCKLES, ETC.

WIRE ROPE

SPECIAL ROPES FOR LUMBERING
DOMINION WIRE ROPE Co., LTD
MONTREAL, QUE.

EVERY LUMBERMAN WANTS IT

35 cents buys it

Scribner's Lumber and Log Book

BRIMFUL OF EVERY-DAY
PRACTICAL INFORMATION

Address :

THE CANADA LUMBERMAN, Toronto

STEAM BOILERS



Portable Boilers—Locomotive Style
Return Tube Tubular

Tanks, Water Towers, Smoke Stack, etc.

CANADA FOUNDRY COMPANY, LIMITED

Head Office and Works: TORONTO, ONT.

District Offices: Montreal Halifax Ottawa Winnipeg Vancouver Rossland Calgary

ENGINEERS

FOUNDERS

MACHINISTS

BUHL MALLEABLE
COMPANY,
DETROIT, MICH.

Elevating, Conveying and Power
Transmitting Machinery

SPROCKET CHAIN AND WHEELS

MALLEABLE OR STEEL BUCKETS

We Guarantee our Goods to be of Standard
Design and Unexcelled Quality.

Belt Conveyors and Spiral Steel Conveyors

The Fairbanks Company

MONTREAL TORONTO VANCOUVER WI EG



Garlock Packing Co.

HAMILTON - - - CANADA

—SOLE MANUFACTURERS OF—



GARLOCK'S PACKINGS

PATENTED

Asbestos and Mineral Wool Pipe and Boiler
Coverings, Engineers' Supplies in General



THE CANADA LUMBERMAN AND WOOD-WORKER

VOLUME XXV.
NUMBER 3.

TORONTO, MONTREAL, WINNIPEG, MARCH, 1905

TERMS, \$1.00 PER YEAR
Single Copies, 10 Cents

THE RAT PORTAGE LUMBER COMPANY.

One of the largest manufacturing concerns in Western Canada is the Rat Portage Lumber Company, which was organized in the year 1896 to take over the properties of the Ontario and Western Lumber Company, which was a combination of the Western Lumber Company, the Minnesota and Ontario Lumber Company, the Safety Bay Lumber Company, Cameron & Kennedy and Ross, Hall & Brown. The company commenced operations with a capital of \$500,000, but have expanded the amount of business originally done to such vast proportions that to-day the capital invested amounts to the sum of \$2,000,000. They own mills at Rat Portage, Norman and Rainy River in Ontario, Winnipeg, Manitoba, and Vancouver and Harrison River, B.C.

The eight mills operated by this company have a combined capacity of over one hundred and twenty five million feet annually and constitute one of the largest lumbering plants in Canada.

The Rat Portage mill is 182x56 feet, with a wing 48 x35 feet, and boiler house 48x46 feet, containing seven boilers and one 30x48 Corliss engine. The engine has a 24x30 inch cylinder, which is equipped with Crow's Nest condensers, enabling the water to be pumped back into the boilers at a temperature of 200 degrees. The mill is

equipped with one Prescott double cutting band, manufactured by the Wm. Hamilton Manufacturing Company, of Peterboro, one Waterous band single cutting 40 inch Wickes gang, driven by 14x16 engine, and two edgers, one being very heavy and from the Diamond Iron Works, of Minneapolis. The log deck is equipped with steam kickers, loaders and niggers, the carriages being worked by a 10 inch steam feed.

The planing mill and sash, door and box factory, which were unfortunately burned down last summer, are being rebuilt on a very elaborate scale. The planing mill and box factory are to occupy a two-story building 132 by 56 feet. McGregor, Gourlay & Company, of Galt, are supplying all the machinery for the equipment, which consists of dimension planer, three matchers, double surfacer, moulder, band resaw and rip saws, all for the planing mill. In the box factory there will be two surfacers, four

sets of rip and cut off saws, two box board matchers, band re-saw, railing machine, three turning lathes, block and spindle machines.

The power house of the planing mill is to be of solid stone with iron roof 50x48 feet. It will contain four boilers and a 20x24 engine, also a complete electric light plant.

The company manufacture at Rat Portage about 175,000 feet of lumber in ten hours, consisting chiefly of white and red pine.

The Norman mill is situated one and one-half miles west of Rat Portage. It is 200x50 feet, with a wing 25x40 feet, and is equipped with an Allis telescopic double cutting band mill manufactured by the Waterous Engine Works Company, of Brantford, one rotary and



RAT PORTAGE LUMBER COMPANY—SAW MILL AT RAT PORTAGE.

one 38 inch gang saw. The carriages are operated by a 9x11 inch steam feed, and the band saw by a 16x20 inch cylinder engine. The main engine has a cylinder 24x30 inch. There is also a battery of eight boilers.

The planing mill in connection is 32x70 feet, and the warehouse 24x40. The equipment includes a dimension planer, surfacer, three matchers, sticker, and a 55 inch Connell & Dengler re-saw operated by a separate engine. The dry kiln in this department was supplied by the A. R. Williams Machinery Company, of Toronto. It is 130x20 feet and can handle 12,000 feet per day. The mill has a capacity of 175,000 feet of lumber per day. There is a tie mill in connection, with a capacity of 4,500 ties in ten hours.

The Rainy River mill is situated at the town of Rainy River, close by where the Canadian Northern Railroad crosses the Beaudette bridge on its way from Minnesota into New

Ontario. It stands on a site of 15 acres and is equipped with a double cutting band saw, twin circular and gang. It has a capacity of 125,000 feet. Mr. Donald Robertson, who has been in the employ of the company a number of years, is in charge.

The Winnipeg mill is situated at Norwood, a suburb of that rising city. It is equipped with a double cutting band and gang edger and has a capacity of 65,000 feet in ten hours. The planing mill attached has two matchers, surfacer, moulder and band re-saw. The company also have a large wholesale warehouse on Higgins avenue, Winnipeg, and one in Brandon for handling the western trade.

In and around the Rainy River country both in Minnesota and Ontario the company own immense limits of white and red pine, it being estimated by the directors that they have enough on hand to supply them for the next twenty-five years without further purchases. The logs are cut and floated down the rivers and lakes to Rainy River and Rat Portage, but unfortunately for the Winnipeg mill they have to be carried there by the Canadian Northern Railway, and some difficulty has been experienced in securing logs on account of the railroad's lack of rolling stock.

Before touching upon the British Columbia mills, it

may be mentioned that the town of Rat Portage depends almost entirely on the Rat Portage Lumber Company for its means of sustenance. It is a town of 5,000 people situated at the principal outlet of the Lake of the Woods. From it all the product of the company's mills are shipped via the C.P.R. to the prairies. The Lake of the Woods is the largest body of water touched by the C.P.R. from Vancouver to Port Arthur. It is studded with islands and is a favorite resort for sportsmen and pleasure seekers.

The mill of the Rat Portage Lumber Company at Harrison River was completed last summer. It occupies a site of 26 acres on the site of the old mill of the Harrison River Milling and Trading Company, and consist of a saw mill, shingle mill, planing mill and sash and door factory. The saw mill is 308 feet long by 66 feet wide, with a wing attached 40x120 feet. It is equipped with gang and band saws.

The double cutter installed will handle both round timber and cants. It has a capacity of 120,000 feet per day and the shingle mill 100,000 shingles a day.

On March 15th, 1903, the Rat Portage Lumber Company bought the saw and shingle mills of W. L. Tait situated on the south side of False Creek, and immediately commenced work on vast improvements and extensions.



RAT PORTAGE LUMBER CO.—SKIDDING GANG, McLEOD'S CAMP, SEINE RIVER.

The property when bought had a capacity of 40,000 feet of lumber and 50,000 shingles a day of ten hours, but with the installation of new machinery the lumber mill output has been increased to 80,000 feet a day.

Among the improvements is a double cutting band, the first to be installed in British Columbia. It was manufactured by the McDonough Company, of Euclaire, Wis. An automatic trimmer has been installed by the same firm, a clash table by the Allis Chalmers Company, a new boiler of 100 h. p. and a blower for the planers by the W. Thompson Company, of Vancouver. In the mill yard an

its manufactured products, they purchased along the coast over 6,000 acres of fir, cedar and spruce. They are now endeavoring to make a specialty of hardwood shipments and building materials.

The main building is 60 x 200 feet, the boiler house, constructed of non-combustible materials, being attached to it. The planing mill is 50 x 120 feet, and is equipped with five planers,

being situated at right angles to the mill.

The officers of the Rat Portage Lumber Company are: D. C. Cameron, president and general manager; Wm. Robertson, secretary, and G. E. Young, cashier and treasurer. The board of directors consists of D. C. Cameron, H. W. Kennedy, Walter Ross, J. B. Monk and Wm. Robertson.

WOODEN TIE-PLATES FOR RAILWAYS.

Upon the advice of the U. S. Bureau of Forestry, the Gulf, Colorado and Santa Fe Railroad eight months ago began to experiment with wooden tie-plates. These plates

The Santa Fe placed cypress tie-plates one-quarter of an inch thick on several thousand old and much-worn cypress ties laid in its track north of Galveston, Tex. After eight months of constant use the plates are perfectly sound and show practically not a trace of wear.

The Bureau of Forestry will now make similar experiments with red gum, red oak and beech tie-plates, which will be placed in the tracks of the St. Louis and San Francisco, the Burlington, and the Northern Pacific systems.

NEW TIMBER LAND COMPANY.

There has recently been incorporated a stock company under the laws of the Dominion, under the title of the McLennan Timber Lands & Lumber Company, Limited, the purpose and business of which is the purchase and sale of Canadian timber lands. This new company is the out-growth of a business carried on for the last two or three years by John McLennan, of the City of Quebec, and whose business is taken over by the company.

Mr. McLennan has carried on a very successful business in the purchase and sale of Canadian timber lands, and the new company



LOAD AT GRAHAM & HORNE'S CAMP, RAINY RIVER.—101 LOGS.

will continue under his management. They have already established a branch office at No. 9 Central Chambers, Ottawa, and continue their headquarters at the City of Quebec.

The officers of the company are: John McLennan, president and general manager; C. E. Taschereau, treasurer and secretary and manager of the Quebec office; and Arthur J. Price, vice-president and manager of the Ottawa branch office.

In extending the operations of the company to the Ottawa district, the company hope to secure such pine territories as may be for sale in that territory, and also to extend the scope of their business into the western provinces. The company is capitalized at \$50,000, practically all of the shares being held by its present officers.

There is at the present time a ready sale for Canadian timber lands among the American lumbermen and paper manufacturers, and through the wide acquaintance of Mr. McLennan in the United States, it is safe to assume that a large amount of American capital and enterprise will be brought into Canada through the agency of this company, for which we predict success.



RAT PORTAGE LUMBER CO.—LANDING ON RAINY RIVER, 10,000,000 FEET.

elevated transfer for loading the timber on the cars for shipment has been added. The estimated cost of these additions and improvements is \$20,000.

The company have built up an extensive business at this mill, doing a large domestic trade and having made two or three shipments to the Japanese Admiralty. To supply timber for the mill and the fast growing demand for

are intended to protect the tie from wear under the rail. They are cut the width of the bottom of the rail and as long as the tie is wide—usually 6 or 7 inches—and are kept in place by the weight of the rail, in a flat groove in the tie. The results of the experiment are of much interest both to the railroads of the country and to those who have at heart the cause of forest protection.

ANNUAL MEETING OF ONTARIO LUMBERMEN'S ASSOCIATION

The annual meeting of the Lumbermen's Association of Ontario was held in the Council Chamber of the Board of Trade Building, Toronto, on Monday, February 6th, the president, Mr. W. D. Lummis, presiding.

Among those present were : W. D. Lummis, Sarnia Bay Lumber Company ; J. B. Miller, Parry Sound Lumber Company ; W. B. McLean, Conger Lumber Company, Toronto ;



MR. J. B. MILLER,
President Lumbermen's Association of Ontario.

the death of our lamented confrere, Mr. John Bertram. He was personally known to all of us operating in this province, and wherever known was universally liked and respected. He was a many-sided man, being concerned in other industries and channels of activity as well as lumbering. In all that he did he was a man of broad views and far-seeing sagacity. He has been called the father of the present saw-log policy adopted by the Government of this province, to which, more than any other factor, is due the growth and prosperity of the lumbering business and more particularly of the milling and manufacturing portion of the business in this province during the past few years. His memory will not soon depart from us.

So far as the condition of the trade is concerned, I regret that I am not able to say that since our last meeting conditions have to any very great extent improved, and while I am hopeful of the outlook at present, I must admit that I am not too hopeful. I do anticipate that with the curtailment of the output during the present season prices of lumber must advance somewhat by about autumn. Much, of course, depends upon conditions which it is not altogether possible to define. I see nothing in sight to check the progress of the United States to the south of us, which forms a very large portion of our market, and I confidently expect a continuance of the expansion and progress of our own country. The depression which exists not only in lumber, but in other branches of industry in England, is undoubtedly continuing, and I cannot say that at present I see any immediate prospect of betterment there, but I hope that the expansion in our own country and in the United States will compensate for the stagnation in the Atlantic export trade, and this, with the curtailment in production to which I referred a moment ago, should ensure stability of prices.

The labor situation, which it was hoped would have improved, cannot, so far as my observation goes, be said to have improved to any noticeable extent so far this winter. It is perhaps a matter for congratulation to the country as a whole that things are so prosperous and expansion proceeding at such a rapid rate that the demand for labor remains as keen as it is, and while conditions continue as they are, it is possibly not to be hoped that the labor situation in the lumber business will improve. Recognizing that, we must make our calculations accordingly. So far as I can see there is no hope that an improvement in the labor conditions will enable us to in any way offset the increased cost of supplies.

The most important matter which we have to deal with at the present meeting is that of the proposal to place an import duty on lumber and timber coming into the country, and we are pleased to find our western brethren so strongly and unitedly with us upon that question, and also that the Canadian Manufacturers' Association are so strongly assisting us in this direction. I do not propose to deliver you any address upon that subject. I fancy that the reasons why such a duty should be imposed are well understood by all the gentlemen before me. With the large and representative delegation which we will be able to present at Ottawa to-morrow, so thoroughly representative of an interest which is such a large one in our country, being, in point of financial importance, the fourth among our great productive industries, and feeling as strongly as I do the fairness of what we are asking and the strength of the case we shall be able to present to the government, I sincerely hope that we shall receive favorable consideration and we shall be able to make the Dominion government see that it is in the interest of the country to grant what we ask.

If we can succeed in having the duty placed at a figure equal to that imposed upon our lumber going to the United States, I am well assured that we might reasonably expect steady, satisfactory and comparatively prosperous business for some years to come. The expansion of our own market and increased demand for lumber in our own country would of itself be sufficient to put the trade upon a satisfactory basis, and if the result ultimately should be the removal of the American duty and also of ours (if one imposed), I, for my part,

would consider that a consummation devoutly to be wished for in the interest both of the lumber producing and lumber consuming industries.

W. D. LUMMIS, President.

The Secretary submitted to the meeting the usual statistical report of white pine production and stocks, which was as follows :

SECRETARY'S STATISTICAL REPORT.

Gentlemen,—I beg to submit for your consideration the following statistical information, based principally on the replies to my circular letter of January 23, 1905.

PRODUCTION OF WHITE PINE LUMBER.

The total production of mills in North-Western Ontario, which embraces all mills on Georgian Bay, Northern Division of the Grand Trunk Railway to Callendar, and Canadian Pacific Railway, North Bay to Rat Portage—the total production for 1904 is approximately 500,000,000 feet B.M. The comparison with former years is :—

Year.	Cut.	Stocks on hand.
1899.....	351,000,000 ft.	120,000,000 ft.
1900.....	476,000,000 ft.	216,349,000 ft.
1901.....	466,000,000 ft.	181,000,000 ft.
1902.....	510,000,000 ft.	170,000,000 ft.
1903.....	485,000,000 ft.	150,000,000 ft.
1904.....	500,000,000 ft.	110,000,000 ft.

In regard to the lumber on hand for 1904, the quantity given is what I estimate there is at the mills now for sale, but does not include what is sold awaiting spring delivery. In regard to lower grades, mill culls and under, there is absolutely none on hand at the mills, and the prospects of good demand for next year are excellent.

As to prices, the answer to my query as to prices being maintained on the basis of last year are unanimous that they will be. Some stocks have already been sold at an advance over last year.



MR. W. B. TINDALL,
Secretary-Treasurer Lumbermen's Association of Ontario.

In regard to the probable production for next year, I estimate this at 550,000,000 feet.

Last year the statistics were given for the competing points of the United States, namely, States of Michigan, Minnesota and Wisconsin, which showed a decrease in production from 1902 of 502,543,000 feet. The decrease from 1903 to 1904 is :

Production 1903.....	4,791,852,000 feet
Production 1904.....	4,219,840,000 feet

Decrease, 1904..... 572,000,000 feet
or a total decrease for last two years of 1,074,555,000 feet.

R. H. Roys, Saginaw Lumber and Salt Company, Sandwich ; J. C. Shook, The Dickson Company, Peterboro ; Robert Watt, Wiarton ; W. J. Maitland, Maitland, Rixon & Company, Owen Sound ; R. Laidlaw, Toronto ; J. E. Keenan, Owen Sound ; R. Cook, South River Lumber Company ; George Thompson, Goderich ; J. Turner and Dwight J. Turner, Turner Lumber Company, Midland ; E. B. Harrison, John Harrison & Sons, Owen Sound ; J. P. Newman, Wiarton ; A. B. Gordon, Booth & Gordon, Sudbury ; William Laking, Hamilton ; C. Beck, C. Beck Manufacturing Company, Penetanguishene ; and W. B. Tindall, Secretary-Treasurer of the Association.

After the reading of the correspondence, the President delivered the following address :

PRESIDENT'S ADDRESS.

GENTLEMEN :—It affords me very great pleasure to see at this meeting such a large and representative gathering of the lumbermen of Canada. I am particularly pleased to see such a large representation of our western friends, who, while they operate under conditions differing considerably from those to which we in Ontario are accustomed, nevertheless find that their interests are to a large extent identical with those of their eastern brethren.

It is not at all necessary for me at this day and age to dwell upon the value of our meeting and of consultation and discussion upon those matters in which we are vitally interested. The presence of so many here is a sufficient demonstration that we are all of one mind upon that subject.

Since our last meeting we have suffered a sad loss in

Stocks on hand show an increase :

1st January, 1904.....1,964,552,000 feet
1st January, 1905.....2,171,703,000 feet

Increase 207,151,000 feet

W. B. TINDALL, Secretary-Treasurer.

The President's address and statistical report were adopted.

The subjects of staking of flat cars and demurrage were discussed at some length, and the following resolutions were unanimously adopted :

"Resolved, that the Railway Companies be requested to meet a committee of this Association, at a time and place to be arranged, to discuss the question of staking of flat cars, which has become a matter of considerable expense owing to the increase in the price of lumber."

"Whereas the lumber dealers of Ontario are suffering at the hands of the railways from the unfair working of demurrage charges, whereby on account of uncertain car supply at shipping points and the great irregularity in forwarding cars, the result is that a number of cars for one consignee accumulate in transit, and all are placed at one time on siding to be unloaded, demurrage being strictly assessed without regard to cause of accumulation : Be it resolved that the Lumbermen's Association of Ontario protest against these unfair conditions and join with the Canadian Manufacturers' Association in presenting this question of demurrage charges before the Railway Commission for an equitable settlement."

Regarding the question of staking, it was stated that the cost had greatly increased owing to the enhanced value of timber and was now about \$1.50 per car. Mr. Dwight J. Turner stated that he understood that in some parts of the Southern States the railway companies were compelled to furnish iron stakes.

Then came up for discussion the important question of interviewing the Dominion Government in the interests of an import duty on lumber. The discussion indicated that those present were almost unanimously in favor of imposing a duty equal to the American duty. Mr. J. Turner, who was once a large operator in Michigan, spoke in favor of a reciprocal arrangement and pointed out that this could not be hoped for unless the Canadian Government took some steps to afford a measure of protection to Canadian lumbermen equal to that given the lumbermen of the United States. The people of the United States would have no reason to object to a Canadian duty on lumber, as it was no more than they would expect.

During the discussion it was stated that the projected railways in Canada will open up large hardwood areas and that the hardwood industry would become of greater importance and should be duly considered in any legislation which might be asked for. It was the feeling of the meeting that a duty should be placed on all classes of lumber excepting oak, walnut, mahogany, sycamore and rosewood, which woods are not to be found in any quantity in this country. The movement for a duty, it was stated, is being actively supported by the Canadian Manufacturers' Association.

It was resolved that a delegation should leave for Ottawa on the evening train with the object of interviewing the Dominion Government regarding a duty.

The election of officers resulted as follows : President, J. B. Miller, Toronto ; 1st Vice-

President, Robert Watt, Warton ; 2nd Vice-President, Dwight J. Turner, Midland ; Secretary-Treasurer, W. B. Tindall, Toronto ; Board of Management, J. B. Miller, W. D. Lummis, R. Laidlaw, R. H. Roys, D. L. White, Robert Watt, W. J. Sheppard, Dwight J. Turner, W. P. Bull, W. J. Ard, W. B. McLean and George Thompson.

THE NEW COMMISSIONER OF ONTARIO CROWN LANDS.

Through the accession of the Conservative party to power in Ontario, the Crown lands of the province have been placed under the control of a new administrator, in the person of Hon. J. J. Foy, K.C., whose portrait we are permitted to show herewith. Mr. Foy is one of the most prominent and respected members of the Ontario bar. He is a native of Toronto, and was born in 1847, his father being the late Mr. Patrick Foy, a merchant of Toronto.



HON. J. J. FOY, K.C.
Commissioner of Crown Lands for Ontario.

He was educated at St. Michael's College, and later carried on his studies at Ushaw College, England. He was called to the bar in 1871, and soon built up a large and extensive practice. He became a member of the firm of Thorne & Foy, later of the firm of Foy, Tupper & Macdonald, and lastly of the firm of Foy & Kelly. In 1881 Mr. Foy was chosen one of the four members to represent the junior bar of Ontario in the Law Society, and in 1886 and subsequent year he was again elected a bencher. In 1883 he was appointed a Queen's Counsel. The firm of which he is now a member stands very high in the profession.

Mr. Foy is also connected with a number of financial enterprises in an executive capacity. He is universally respected by every citizen of Toronto as a man of undoubted integrity, ability and good citizenship in every respect. He has represented South Toronto in the Legislature since 1898. In 1902 he received the degree of L.L.D. from the University of Toronto.

Trade Opportunities

CASING AND CAPPING.

MR. JOHN B. JACKSON, Commercial Agent for Leeds and Hull, England, sends the following to the Department of Trade and Commerce, Ottawa :

"A very large quantity of electric lighting casing and cappings are used in this district, the greater quantity being of whitewood from the United States. They are required planed and grooved. I should think white-pine or basswood very suitable. Several inquiries have been made to me as to the probability of Canadian timber men supplying this increasing trade.

The following are the principal sizes used :—

Total width.	Size of grooves.	Distance between grooves.
1 1/8-inch	3/16-inch	3/8-inch.
1 1/2 "	1/4 "	1/2 "
2 "	5/16 "	3/8 "
2 1/2 "	3/8 "	1 "
3 "	3/8 "	1 1/8 "
3 1/2 "	3/4 "	1 1/4 "
4 "	7/8 "	1 3/8 "

These sizes are worth wholesale from 35 cents to \$3 per 100 feet."

INQUIRIES RECEIVED.

By P. D. McNamara, Manchester, Eng. : No. 78—A large soap manufacturer, who can use very large quantities of box-boards, desires to get in touch with Canadian shippers of same who can keep him supplied with regularity.

By W. A. McKinnon, Bristol, Eng. : No. 12—A local firm desires to be brought in touch with manufacturers of Venetian blind laths and wood cornice poles. No. 14—A British firm wants quotations on Canadian oak delivered Cardiff or Barry.

By J. B. Jackson, East Parade, Commercial Agent for Leeds and Hull : No. 84—A large manufacturing firm of electric lighting and bell accessories, dealing in very large quantities of wood-casings therefor, desire to be put in direct communication with Canadian saw mills ready to export the same.

By P. B. Ball, Birmingham, Eng. : No. 127—Several firms are open to purchase all kinds of wooden handles, particularly hammer and shovel handles.

By the Department of Trade and Commerce, Ottawa. No. 57—A New York firm makes inquiry for one million white oak hand dressed staves.

By the High Commissioner for Canada, London, Eng. : No. 195—Inquiry is made for the names of parties in Canada in a position to supply large quantities of maple rollers for use in wall paper printing. The wood must be seasoned, with a two-inch bore and painted ends. No. 204—Inquiry is made for names of Canadian exporters of dowels (3-8 to 1 inch), chair and table legs turned from maple or birch, cornice poles, oak barrel staves and tops and copper ore.

By the City Trade Branch of the High Commissioner's Office, London, Eng. : No. 121—A firm in Manchester asks to be placed in communication with Canadian manufacturers of oak barrel tops and bottoms and staves ; cornice poles, rings and ends ; spring blind rollers ; wood washing boards. No. 132—A manufacturing company asks to be placed in communication with Canadian firms who can supply orham wood cut to sizes for the manufacture of furniture ; also with shippers of birch boards, 1/2, 3/8 and 1 1/4 inch, about 16 inches broad, dressed and ready for the manufacture of chairs. No. 135—A firm importing woodenware and turnery of all kinds would like to be placed in direct communication with Canadian manufacturers of woodenware, handles and maple blocks and squares.

The names of the firms making the above enquiries, with their addresses, can be obtained upon application to the Superintendent of Commercial Agencies, Department of Trade and Commerce, Ottawa. Mention the reference number and the Commercial Agent in each case.

JOTTINGS BY THE WAY

Leaving Toronto, I went direct to St. Thomas, and I was pleased to see the town so full alive and progressive. It certainly boasts of wide-awake lumbermen and up-to-date planing mills. The new planing mill belonging to Harry Lindop is one of the best I have ever seen and is the result of years of experience learning what a modern planing mill should be. The building is composed of concrete cement blocks right up to the roof, with a magnificent driveway through the centre of the building. The latter has a frontage of 90 feet and a depth of 110 feet, to which another addition of 30x60 feet is to be added. Despite the fact that Mr. Lindop has had two or three disasters (the last of which was a complete burn-out last May), he has proven equal to the task, and his modern establishment speaks for itself. I should call Harry Lindop a young old man of the progressive type. In taking me through the building he spoke modestly of his disasters and of how he arose again each time with renewed energy for the work. A 75-horse power engine provides the motive power for some of the latest improved machinery. Harry has a mill in the Parry Sound district which supplies him with his lumber, and he very kindly gave me a photo showing himself inspecting a log "dump" at his mill.

Among the lumbermen who are now importing extensively the southern yellow pine is J. M. Green & Sons, Limited, of St. Thomas. They were among the first Canadians to bring this lumber into Canada. Young Mr. Green, who escorted me through their establishment, is a young lumberman of brilliant ideas and is the active manager. He states that they are using more hemlock for building purposes than ever before. I was particularly struck with the excellent manner in which their dry kiln, storage sheds, and the interior of the planing mill was laid out. The latter building is of brick, three stories high, with a tramway for bringing the lumber to be dressed directly to the machinery. I have been in some planing mills where men had to carry boards over piles of saw-dust and heaps of shavings to get them to the planer. Here I found a clear space around the machines in this mill,

lumber, doing a splendid trade. Hemlock is used altogether for bill stuff and gives satisfaction.

On my way to Detroit I met Mr. James Little, of the Rat Portage Lumber Company, and formerly of Barrie, Ont., who was on his way back to Rat Portage with his wife and daughter.

Mr. Little has not only been an experienced lumber camp superintendent, but a foreman of river drives, and has a store of knowledge. Twenty-eight years of lumbering has left him still a young man. I had met down in Nova Scotia a lumberman who had told me that hemlock existed wherever white pine grows. When I got over in Minnesota and Iowa last year I was convinced that while hemlock was plentiful on the east bank of the Mississippi, to the west of the river it was practically non-existent. While in Northern Wisconsin I saw great forests of hemlock, but west of the St. Croix river, in Minnesota, there was not a tree. Mr. Little verified this by saying he had seen no hemlock in upper New Ontario or in Northern Minnesota.

I asked Mr. Little what his experience was with the "lumber jack." He said the day of the hardy French-Canadian was over. The "Canuck" always has been the typical "lumber jack." He worked hard, thrived on pork and beans, spent his money with "the company" and could be relied on to come back for the next season. Next to the Canadians come the Swedes and Norwegians. They are good workers, but spend little of their wages, saving to get a start at something else. While the method of feeding the woodsmen has improved, the work done is not as good as in the palmy days of 1880—just a quarter of a century ago.

Indians and half-breeds, Mr. Little says, make good river drivers, but cannot be depended on after the 25th of June or when they get their treaty money. After the 1st of July they go on the hunt, also fishing or berrying. They are, however, good at contract work, cutting ties, etc.

From St. Thomas to Detroit I took the Pere Marquette Railway. This company have become the great central route since they absorbed the Lake Erie & Detroit River Railway and the C. H. & D. Railway. The original Pere Marquette was a logging road. It is to-day one of the best equipped and foremost of railways. They are bound, with their magnificent equipment and great lake ferries, to secure increasing business with lumbermen.

In Detroit several lumbermen told me of their sympathy for Mr. Horace A. Ross, of the C. W. Restrict Lumber Company, whose beautiful six-year-old boy had both his legs cut off in a railway crossing accident. The poor little fellow was running home from school when he met with the sad accident.

The American Column Company, of Battle Creek, are contemplating entering the Canadian field with their colonial columns. They only cater to the highest class business, turning out fine products for the architects and builders.

At Kalamazoo I had the pleasure of meeting Mr. Shepardson, the genial manager of the W. E. Hill Company, whose famous saw-mill machinery is well

known all over the continent. Their output is of the high-grade order. Mr. Shepardson is an old Hoo-Hoo and knows how to welcome a visiting black cat.

The Battle Creek and Kalamazoo lumbermen reported fairly good business for January and all looked forward to a banner season this year.

A pleasant run to Beloit, Wisconsin, showed the city to be progressing. I visited the Mathison Machine Works, the Berlin Machine Works and the Dowd Knite Works. These progressive and up-to-date concerns are shipping to all parts of the world.

When I struck Minneapolis for the Northwestern Lumbermen's Convention, the city had already been

struck by a terrific blizzard which gave the lumber-jacks a touch of 30 below zero weather.

Over two thousand lumbermen with five or six thousand visitors thronged the great Convention Hall daily to hear the speakers and see the exhibits. Practically the whole north-western territory was represented, consisting of the States of Minnesota, Wisconsin, Iowa, Nebraska, and the two Dakotas. The convention is the largest of its kind held in the United States.

I was cordially welcomed and given space on the main floor for an exhibit of Canada's lumber journal.

These north-western lumbermen are about the most self-reliant, good-natured fellows I ever met. Here and there were pioneer dealers—men who had carved



W. G. HOLLIS, Secretary Northwestern Lumbermen's Association, Minneapolis.

their way into the forest when it was a wilderness. Mayor Jones welcomed the boys. The Cypress Manufacturers' Association of Louisiana sent C. H. Cross to represent them. A. S. Osborn, of Oshkosh, represented the North-western Hemlock Association, Harry Collins the Pacific Coast Dealers' Association, and H. S. Gilkey held up the North-western Cedarmen's Association. President Barry, of Iowa, opened the convention and Secretary W. G. Hollis, of Minneapolis, read the annual reports. J. E. Rhodes, of the Mississippi Valley Lumberman, spoke on "White Pine," whilst N. W. McLeod extolled the virtues of "Yellow Pine."

The various divisions of the lumber industry had a fine display in the exhibit rooms, many of the World's Fair exhibits being placed on view. The whole made one of the most elaborate displays ever seen.

To Secretary Hollis (who was re-elected) is due great credit for the whole affair. He had a splendid staff of assistants.

We all attended the Lyceum Theatre, kicked up "high-jinks" generally, had a flash-light photo taken at midnight, chased the kittens at the Hoo-Hoo concatenation till we were tired, and (as Mayor Jones promised us) we were not molested.

I came upon the train to Winnipeg with a number of the Northern Minnesota and North Dakota retailers. They all report a splendid outlook for this season.

IT DOES THE BUSINESS.

As an example of the satisfactory returns derived from advertising in the CANADA LUMBERMAN, we quote as follows from a letter just to hand: "On January 22nd and 23rd we wrote you to cancel our ad. in your paper (Wanted, a man to sell lumber and shingles). We are still receiving letters about the matter, which are a bother to us, and if the ad. has not been cancelled kindly have it attended to." Publication of this ad. ceased on January 30th, but on February 16th, the date of the above letter, replies were still coming in. If you want to buy or sell anything in the lumber or wood-working field, an advertisement in this paper will do the business for you.

The Goldie & McCulloch Company, Galt, Ont., have installed a 50 h.p. engine and boiler in the new foundry of Clarke & Demill at Hespeler, Ont.



VIEW AT HARRY LINDOP'S LOGGING CAMP, SAND LAKE, ONT.

the driveway extending from the street through the center of the building to the lumber sheds and lofts. The planer is on one side of this driveway, and the matcher on the other, which saves a lot of handling.

Among the most progressive citizens of St. Thomas are Marlatt & Smith, the yard men, who handle all kinds of lumber and building material; and Balsden & Blewett, who not only operate a planing mill, but are contractors and builders of local repute. This latter firm make sash, doors, blinds, cisterns and flooring, getting their material from Sarnia and Tonawanda. They handle considerable hemlock and B. C. shingles.

Sanders & Powers, of St. Thomas, are also importers of yellow pine and wholesale dealers in all kinds of

THE Canada Lumberman

AND WOOD-WORKER

(Monthly and Weekly Editions—One Dollar Per Year.)

PUBLISHED BY

The C. H. Mortimer Publishing Company
of Toronto, Limited,

CONFEDERATION LIFE BUILDING, TORONTO

BRANCH OFFICES:

38 ALLIANCE BUILDING, MONTREAL
720-721 UNION BANK BUILDING, WINNIPEG
22 GREAT ST. HELENS, LONDON, E. C.

The LUMBERMAN Weekly Edition is published every Wednesday,
and the Monthly Edition on the 1st day of every month.

TERMS OF SUBSCRIPTION:

One Copy, Weekly and Monthly, One year, in advance, \$1.00

One Copy Weekly and Monthly, Six Months, in advance, \$0.50

Foreign Subscription, \$2.00 a Year

ADVERTISING RATES ON APPLICATION.

THE CANADA LUMBERMAN AND WOOD-WORKER is published in the interest of and reaches regularly persons engaged in every part of Canada in the lumber, wood-working and allied industries. It aims at giving full and timely information on all subjects touching these interests, and invites free discussion by its readers.

Special care is taken to secure for publication in the WEEKLY LUMBERMAN the latest and most trustworthy market quotations throughout the world, so as to afford to the trade at home and abroad information on which it can rely in its operations.

Advertisers will receive careful attention and liberal treatment. For manufacturing and supply firms wishing to bring their goods to the attention of owners and operators of saw and planing mills, wood-working factories, pulp mills, etc., the CANADA LUMBERMAN AND WOOD-WORKER is undoubtedly the most direct and profitable advertising medium. Special attention is directed to "WANTED" and "FOR SALE" advertisements, which are inserted in a conspicuous position on front page of the Weekly Edition.

LUMBER INSURANCE.

In last issue we referred to the decision of the Western Retail Lumbermen's Association to establish an insurance department in connection with their association. We have since learned that the lumbermen of British Columbia are up in arms against the insurance companies and that the latter may lose their business with the saw mill men. This is the result of increased rates put into effect about one year ago.

The Lumbermen's Indemnity Exchange, with head office in Seattle, Wash., has been organized, and it is understood that some of the Canadian firms have already transferred their insurance to the new organization.

The old line companies have, by their actions, shown that they are not particularly anxious for lumber risks, and it would appear that in the near future they may be freed from anxiety in that direction. Then they may realize that the premiums which they received from that source constituted a larger item in their total business than they had reckoned upon.

There is one aspect of the mutual insurance movement which is very important, namely, its tendency to encourage the adoption of efficient methods to prevent fire. A policy holder whose property is well insured in a responsible company in which he has no special interest apart from the realization of his claim in the event of a fire, will not adopt precautionary measures to the same extent as the person who is a stockholder in the company providing the insurance and who will profit by any reduction which may be effected in the losses of the company.

The responsibility for the present high rates on Canadian saw mills and lumber rests in some measure, we believe, on the shoulders of lumbermen who have not properly guarded against fires, but have been content to rely

upon the insurance granted by companies often too lenient in respect to the risks they are willing to assume. Greater distinction should have been made between establishments which actually invite fire and those which have been so arranged and equipped as to reduce the fire hazard to the minimum.

LUMBER EXPORTS AND IMPORTS.

The statistics of lumber exports and imports which are to be found in the last annual report of the Department of Trade and Commerce, while not indicative of expansion, are instructive and suggestive and afford abundant food for reflection. With the vast quantity of timber which this country still possesses, it is surely an anomaly that our imports of lumber should appreciably increase while our exports are declining. Yet such is the case.

For the fiscal year ended June 30, 1904, timber products classed as unmanufactured wood were exported from Canada to the value of \$32,990,057, as compared with \$36,268,689 for the previous year, a decrease of \$3,378,632. The value of unmanufactured wood imported into Canada for the last fiscal year was \$7,715,697, as compared with \$5,483,318 in 1903, an increase last year of \$2,232,379. The items which make up these figures will be found on page 19.

The export lumber trade of Canada is not confined to the United States, and lighter shipments to Great Britain are responsible for a portion of the falling off in export business. The lumber imported into Canada, however, comes almost entirely from the United States, so that by an analysis of the exports and imports as affecting that country we may learn the trend of the trade. The exports of unmanufactured wood from this country to the United States for the fiscal year of 1904 were in value \$14,945,783, while for the previous year they were \$16,918,403, thus showing a decline last year of \$1,972,610. The value of the imports from the United States last year was \$6,802,262, as against \$4,832,280 in 1903, an increase last year of \$1,969,982. The result of the past year's business has therefore been largely in favor of the United States as compared with 1903, and it is quite probable that a comparison of the trade of previous years would show a tendency in the same direction.

For every condition there must be a cause. That the lumber exports to the United States are declining at the same time that the imports are increasing is doubtless due in a large measure to the conditions of inequality governing the trade. The Canadian lumber manufacturer is willing and able to compete on equal grounds with the foreign manufacturer, but it is unreasonable to expect that he can manufacture his lumber any cheaper or prosper in business unless afforded an equal measure of protection with his competitors.

To the deputation of lumbermen who recently interviewed Sir Wilfrid Laurier asking for an import duty on lumber corresponding to the American duty, he replied by asking them to trust the Government. If he were sincere in this remark, we may expect favorable action at an early date. It cannot be said that the lum-

bermen have been too hasty. They have carried the burden of unfair discrimination for some years, and are to-day more convinced than ever of the justice of their demands.

THE LIEN LAW.

The Western Retail Lumbermen's Association, of Winnipeg, are endeavoring to secure some amendments to the Lien laws of Manitoba and the Territories. The present law of these provinces provides that a lien upon a building must be placed within thirty days after the material is delivered and be realized upon within ninety days. It is contended that the time limit thus fixed does not operate satisfactorily in practice and frequently causes unnecessary hardship. Lumber and other building material is usually purchased in the spring of the year, and if the farmer is unable to pay for the material at time of delivery, it is improbable that his financial circumstances will change materially within the next three months while his grain is growing. The amendment desired by the lumbermen, and which seems of a logical nature, is that the time allowed in which to realize upon a lien should be extended to, say, nine months, and in the intervening period the farmer would be given an opportunity of marketing his crop. A lien law which is thoroughly workable in its application is of great importance in an essentially agricultural country such as Western Canada, and it is to be hoped that such amendments will be made as will best protect the interests of all concerned.

THE HARDWOOD INDUSTRY.

It is a question if the white pine production in Canada has not already reached its zenith and whether, irrespective of market demands, it will not gradually decline in volume from year to year, as has been the experience of the white pine states of Michigan, Wisconsin and Minnesota. This does not mean, however, a reduction in lumbering operations, but rather that the deciduous trees will provide the raw material for our saw mills to a greater extent than in the past. We possess in plenty such hardwoods as birch, maple, elm, ash and basswood, and the development of the industry is yet in its infancy. The railroads that are being built in the northern part of Ontario and Quebec, as well as the Grand Trunk Pacific, will open up much new hardwood territory which has been as yet untouched.

By the utilization of our hardwoods the country will be greatly benefitted, as they will be consumed by home industries. The growth of manufacturing establishments using hardwoods as their raw material has been such that the demand is rapidly overtaking the supply, and the export trade in hardwood lumber may soon become extinct. Dealers who a few years ago shipped large quantities of lumber to the United States are to-day giving no attention to that market, so great has become the domestic requirements.

Just a suggestion: Would not the hardwood trade be greatly benefitted by the adoption of some standard for inspection rules? The United States is making progress in this direction. Why not we?

CANADIAN LUMBER IMPORTS AND EXPORTS

STATEMENT SHOWING VALUES OF UNMANUFACTURED WOOD IMPORTED INTO CANADA DURING THE FISCAL YEARS ENDED JUNE 30TH, 1903 AND 1904.

(Compiled from Report of Department of Trade and Commerce.)

	1903	1904
(Free)		
Sawed or split boards, planks, deals and other lumber.....	\$ 892,360	\$ 2,663,571
Timber or lumber hewn or sawed, squared or sided.....	690,951	326,760
Logs and round unmanufactured timber.....	389,267	396,348
Cherry, chestnut, gumwood, hickory and whitewood.....	305,657	457,419
Mahogany.....	55,286	138,388
Oak.....	1,268,053	1,492,577
Pitch pine.....	559,045	302,375
Redwood.....		60
Rosewood.....	55	2,397
Spanish cedar.....	10,745	4,630
Sycamore.....	734	68r
Walnut.....	55,608	57,770
White Ash.....	42,392	97,479
African teak, black heart ebony, lignum vitae, red cedar and satinwood.....	8,101	6,473
Battens and pine and spruce clapboards.....	9,893	15,313
Laths, palings and pickets.....	29,652	59,754
Staves and headings.....	111,317	146,580
Hop poles.....	678	
Fence posts and railway ties.....	132,679	202,887
Shingles.....	27,931	22,141
Ship timber and ship planking, N.O.P.....	4,358	2,115
(Dutiable)		
Sawed boards, planks and deals, dressed.....	61,843	176,079
Manufactures of wood N.O.P.....	657,138	930,291
Veneers of wood.....	132,765	149,222
Lumber and timber manufactured, N. E. S.....	39,810	63,387
Total.....	\$5,483,318	\$7,715,697

STATEMENT SHOWING VALUES OF UNMANUFACTURED WOOD EXPORTED FROM CANADA DURING THE FISCAL YEARS ENDED JUNE 30TH, 1903 AND 1904.

(Compiled from Report of Department of Trade and Commerce.)

	1903	1904
Lumber—		
Planks and boards.....	\$14,005,788	\$12,707,912
Deals, pine.....	3,652,467	2,975,614
“ spruce and other.....	8,315,454	7,920,444
Deal ends.....	551,769	407,089
Laths, palings and pickets.....	1,038,912	835,939
Joists and scantling.....	451,194	524,838
Basswood, butternut and hickory.....	71,995	41,251
Battens.....	71,963	39,287
Staves, standard.....	3,314	
“ other and headings.....	281,048	207,490
All other lumber.....	474,918	345,454
Logs—		
Pine.....	139,406	30,306
Spruce.....	59,781	69,110
Hemlock.....	34,264	33,392
Elm.....	15,517	16,519
Oak.....	1,230	535
All other.....	183,930	269,771
Timber, square—		
Pine, white.....	1,310,557	1,530,506
“ red.....	219,991	33,385
Oak.....	413,088	226,759
Elm.....	304,858	160,036
Birch.....	204,690	109,275
Ash.....	27,649	10,635
Maple.....	1,759	
All other.....	69,072	61,658
Pulp wood.....	1,558,560	1,788,049
Shingles.....	1,610,143	1,711,258
Shingle bolts of pine or cedar.....	43,273	35,357
Sleepers and railway ties.....	210,884	188,831
Piling.....	122,494	91,715
Firewood.....	115,769	71,961
Bark for tanning.....	74,816	66,905
Posts, cedar, tamarac and other.....	61,905	24,890
Shooks, box.....	36,269	1,107
“ other.....	403,903	342,354
Poles, hop, telegraph and other.....	57,910	35,463
Match blocks.....	28,095	39,707
Knees and futtocks.....	13,504	12,680
Masts and spars.....	7,368	7,333
Stave bolts.....	5,337	3,995
Lathwood.....	1,077	4,074
All other wood unmanufactured.....	9,768	7,173
Total.....	\$36,268,689	\$32,990,057

let issued by C. Lembcke & Co., 128 Water St., New York, who are the representatives of Huelsberg & Co., of Charlottenburg, Germany, the owners of the patents taken out by Mr. Rueping.

In the new Rueping process the seasoned wood is subjected for about half an hour to one hour to an air pressure of 60 to 65 pounds, so that all cells must be filled with compressed air. This is the principal difference between the old and the new method; with the former the air is removed from the wood cells by a vacuum, whereas with the latter the wood is filled with compressed air.

Without reducing the pressure in the impregnating cylinder, the warmed impregnating fluid is then forced from the tar reservoir into the impregnating cylinder by means of a somewhat higher pressure, say of about 65 to 75 pounds. In proportion to the quantity of tar entering the impregnating cylinder, air is permitted to escape through a valve, in order to make room for an equivalent volume of impregnating fluid. At the same time it must be borne in mind to allow only such a quantity of air to escape as cannot impair the maintenance of the pressure of 60 to 65 pounds. When the wood in the cylinder is completely covered with the impregnating fluid the pressure, according to the dimensions and qualities of the material, is to be increased to 105 to 225 pounds. Under this increased pressure the impregnating fluid will penetrate into the cells of the wood.

It might appear that through the forcible advance of the fluid the compressed air contained in the wood would be forced to the interior and there form a kind of cushion or piston which would render an impregnation of this sort impossible. But, owing to the high pressure, the tar-oil, in consequence of the capillary action of wood and its adhesive properties, moves along the cell walls into the innermost parts of the wood, soaking them entirely, by which the compressed air contained in the cells will be still more compressed and at the same time entirely kept in suspension and inclosed by the advancing tar oil.

When the material is sufficiently impregnated the pressure with great energy, through its expansion, will force as much of the impregnating fluid out of the wood as does not adhere to the cell walls, and this surplus is thus made to flow back into the creosote tank. This is the distinctive feature of the Rueping process.

Accordingly, no more fluid can remain in the wood than is necessary for impregnating, coating or saturating the cell walls, etc., and this is the only important object in view for the preservation of wood. In each case the pressure can be regulated in such a way that only a minimum quantity of fluid (or larger quantities, as required) remain in the cells of the impregnated wood. The oozing of the superfluous tar-oil may be increased and accelerated by exposing the impregnated wood to a vacuum for some time. By this means a further quantity of from 5 to 10 per cent. of the impregnating fluid left in the wood may be regained.

The Columbia River Lumber Company, Golden, B. C., are installing an electric light plant in their mill.

COMPRESSED AIR FOR PRESERVATION OF TIMBER.

The use of compressed air in a new timber preservation process, known as the Rueping, is mentioned in an article on that subject which recently appeared in the Engineering News. The Rueping process is a German invention, the principal object of which is to make commercially practicable the treatment of timber with preservative materials which are of the

highest efficiency but which have only been used to a limited extent on account of their high price.

The plant consists of impregnating cylinders strong enough to carry pressures of 100 to 225 pounds, a tar-oil or creosote tank for pressures of 75 to 120 pounds, an air compressor which may also serve as a vacuum pump, a steam pump, and a boiler. The different stages of the process are described as follows in a pamph-

THE Wood-Worker and Retailer

NEW DIRECTORS OF THE WESTERN RETAIL LUMBERMAN'S ASSOCIATION.

Mr. J. R. Bunn, of Milestone, Assiniboia, one of the two new directors of the Western Retail Lumbermen's Association, was born in Quebec City in 1861 and spent his childhood in that province. While still young he went to live in the county of Gengarry, Ont., and later in Lambton county. Having learned the trade of plasterer, Mr. Bunn, in the early eighties at the age of twenty-one, removed to Winnipeg, where he carried on business as a contracting plasterer till 1885, when he removed to Qu'Appelle Station. There he made his home and followed the plastering pretty closely till 1900, when he turned his attention to the lumber business and established a yard at Milestone, Assa., his present address. Mr. Bunn was the first man on the town site. He has now a line of three yards at Wilcox, Milestone and Lang, with an aggregate turn-over of \$60,000 during the past year.



MR. J. R. BUNN.

Mr. D. L. Lincoln, the other new director, hails from the state of Illinois. Mr. Lincoln started in the lumber business as a boy, first working in the retail yards of the F. M. Slagle Company in Alton, Iowa, where he rose to the managership of that department and later went on the road as auditor for the same company.

Mr. Lincoln tells a story of his first day in the lumber business. He was employed unloading some posts. On going home that night his father enquired how he had got along. "Well, I've been pretty well 'posted' for to-day," replied the youthful lumberman.

Leaving the Slagle Company, Mr. Lincoln went to Minneapolis, where he did the buying for a large lumber company in that city. Several years later, when the Imperial Elevator Company was organized, he was sent to Winnipeg to open business for that company in the Prairie City, which position he still occupies.

LIKES IT.

Mr. J. J. Furey, Jersey City, N.J., writes: "Enclosed is \$1.00 for my subscription. I like your paper and hope you will make it the success it deserves."

TREATING STAVES AND HEADING IN DRYING.

Is there anything new in or about a stave factory? New ideas or new methods are not very plentiful, nor does there seem to be a tendency toward absolutely correct practice, which would be new to everyone in some respects, and in every respect to some. Handling the waste in a crowded place is one of the problems to work out and each place has to work out its own solution. One of the solutions seen lately is a burner on the ground. It is not always possible to put up a standing burner, for they are costly, but it usually is an easy matter to put in a ground burner, as there is little else required but the brick and some sort of a stack. This burner is nothing but a brick oven with the stack at the end, and the pipe from the shaving fan leads in the end at a door, at the top, and this simple arrangement burns up a vast amount of waste in a day. It is nearly full as a usual thing at night, but in an hour or so all the waste is consumed. Its simplicity is its chief feature.

In handling the manufactured stock, if the pieces of heading or the staves were turned over at the right time, which would be as soon as they show signs of turning up from exposure, they would draw back to shape and be practically new. These top staves curl on account of the greater exposure to the atmosphere without the weight of other stock on them to hold them down. When stacked in the open air, the stock will curl and warp much worse than when stacked under sheds, because the exposed surface dries and contracts while the under and more covered surface remains moist and expanded. Turning them over reverses the process that twists them, straightens them and makes them as good as new and fit for use.

At some factories, it is often noted that large lots of staves and heading are left scattered along the road, when they are being transferred from where they are made to the drying stacks, in piles of as many as a hundred, and often a line of staves or heading is piled along near where they are to be stacked at some time, long enough, often, to have all the top pieces warped and twisted from the sun. When they are stacked, the warped pieces go in pile first, and the straight pieces on them. This splits and ruins them, in consequence of the weight of the top pieces causing these crooked pieces to straighten out. Then the top pieces of the stack warp and spoil, showing a large percentage of loss on account of the warped pieces at the bottom or middle of the stack as well as at the top. There are two results to be sought

for in stacking cooperage stock for drying: First, to place each piece so it will have the greatest exposure to atmospheric action, so that the air will circulate freely through the stack, and, as nearly as possible, touch every part of every piece. The next object is to hold the pieces so that the drying process will not change the shape of them.

To insure that staves will curve edgewise to conform to the circumference of the barrel, they are cut on a 10-inch radius, so that, for flour, salt or other slack barrels, they nearly fit without bending edgewise, inside the hoops and outside the head, which approximately corresponds to a 20-inch circle. The matter of maintaining that curve is all-important. Any process that will tend to make the stave flat is to be avoided, therefore staves are never stacked, in a circular stack, as heading is.

To stack staves for drying it is the usual practice to begin on the foundation by laying down three staves far enough apart so that the length of a stave will cover all three, reaching the two outer edges, the thickness of a stack equaling the length of a stave. Then three other staves are placed in a line with and lapping the ends of the three first placed, continuing to place threes until the desired length of stack has been obtained, remembering always to place cut staves with the backs down and making the laps one inch. Some people double the staves, laying on two at a time, fitting together as one, always placing two instead of the single stave, the stacking being otherwise the same as for single staves. The man doing the piling can handle them more rapidly by keeping two together and many believe that staves stacked in this way will dry better and keep a better shape than when stacked singly, claiming the staves are made stronger to resist wrapping when piled in this manner.

The result sought when stacking cooper stock with the ends lapped is to facilitate the passage of air between the pieces. It is also desirable to maintain the stability of the stacks, therefore they are "tied" together with staves at intervals of ten layers, and at each stave length one stave is placed across the stack and the end of another stave is thrust into the pile next, while one end lays on the pile being built, in which they are firmly fastened by the weight of the staves above them when the stack is complete. Each new stack being built should be started 18 inches from the last one finished. Triple stacking, as here mentioned, is desired for staves, also for heading where economy is an item.

Triple stacks of heading are much the same

as if made of staves. The stacks are broad enough for two pieces of heading to reach the edges. A large quantity of stock can be placed in a limited floor space, on account of its compactness, and from its steadiness the pile can be built to a great height, while the stack is materially larger in floor space.

The only objection to these high stacks is in passing the stock up to such a height, or from one pile to another to reach the highest point at which the heading is to be stacked. When these stacks are to be made very high, care must be taken to start on a level foundation, strong enough to stand the weight, any giving of the bottom rendering a pile likely to fall, a result often seen from carelessness in this detail of the work.

As a rule, staves may be placed on the market without being perfectly dry more successfully than can heading. For salt barrels staves from five to six weeks old are often used, if the barrels are filled with salt at once, owing to the damp nature of the salt. When barrels are to be stored empty they should be made from perfectly dry staves, while flour barrels should be made from staves from 15 to 20 weeks old, if the weather has been favorable, and longer during wet weather, before the staves are jointed.

Staves may be passed through a kiln and dried in a week or less, but it is doubtful if they are as good as the air-dried stock. In the kiln-dried stock, the ends are held covered by the other staves in lapping, allowing the middles to cure by the action of the heat from the edge, which causes them to fall short in jointing, causing a greater number to be put in the No. 2 pile and in the culls.

A two-piece or double stack is one in which two pieces are placed side by side on the foundation, then two other pieces are placed a little in advance and in line with the first two, on which they must lap. Where economy of space is not to be considered, and where the most complete exposure to the action of the atmosphere is desirable, heading may be stacked in circular or single tier stacks, thus securing the greatest exposure obtainable. The circular stack is made by laying out a circle as large as may be desired with or without marking. Heading placed on the circle, with each alternate piece two inches less than the length apart, will furnish the start or foundation for lapping each succeeding piece, up to an indefinite height. Heading stacked in this manner is securely held against warping, and has almost the entire surface protected from rain, even in the open air. The weight of the stacks has a tendency to hold the heading straight, and the slow drying of the ends goes a long way towards preventing end-checks.

Circular stacking is a favorite method for tight cooperage, because heading for oil, whisky, vinegar and other tight packages is sawed or riven thin on the heart edge and thick on the sap edge. In riv'd stock the thickness at heart and sap is very great. In sawed tight heading, the difference is more regular, though indefinite, because if the machine is set to saw 5/8 inch on the heart and 1 inch on the sap at 14 inches wide, then when sawing pieces 6 or 8 inches wide it will make the thin edge thicker or the thick edge thinner, keeping the pieces with the grain, sawing a waste piece from the sap side or edge and not reaching to

the heart. The thick and thin edges of tight heading make it accommodate itself nicely to a circular stack, because the thin edge is always turned inward, which, fitting and lying snugly, makes a neat and firm stack. Placing the thick edge outward gives it more exposure to the sun and air. If stacked in straight stacks the thick and thin edges would necessarily be placed alternately and only a few thick edges be exposed to the sun.

The undesirable features about triple stacking are that the stack is thick and compact, while the usual excessive laps hinder or almost prevent the proper circulation of air round the

into whose hands the business falls to decide on a line of procedure, and see to it that all the details are attended to correctly. It is as easy (and a good deal safer) to do work correctly, as it is to do it wrong, and a good deal more profitable.—Packages.

LARGEST WATER WHEEL IN EXISTENCE

The illustration on this page represents a 10,500 h.p. water wheel which the I. P. Morris Company, of Philadelphia, recently installed in the power house of the Shawinigan Water and Power Company at Shawinigan Falls,

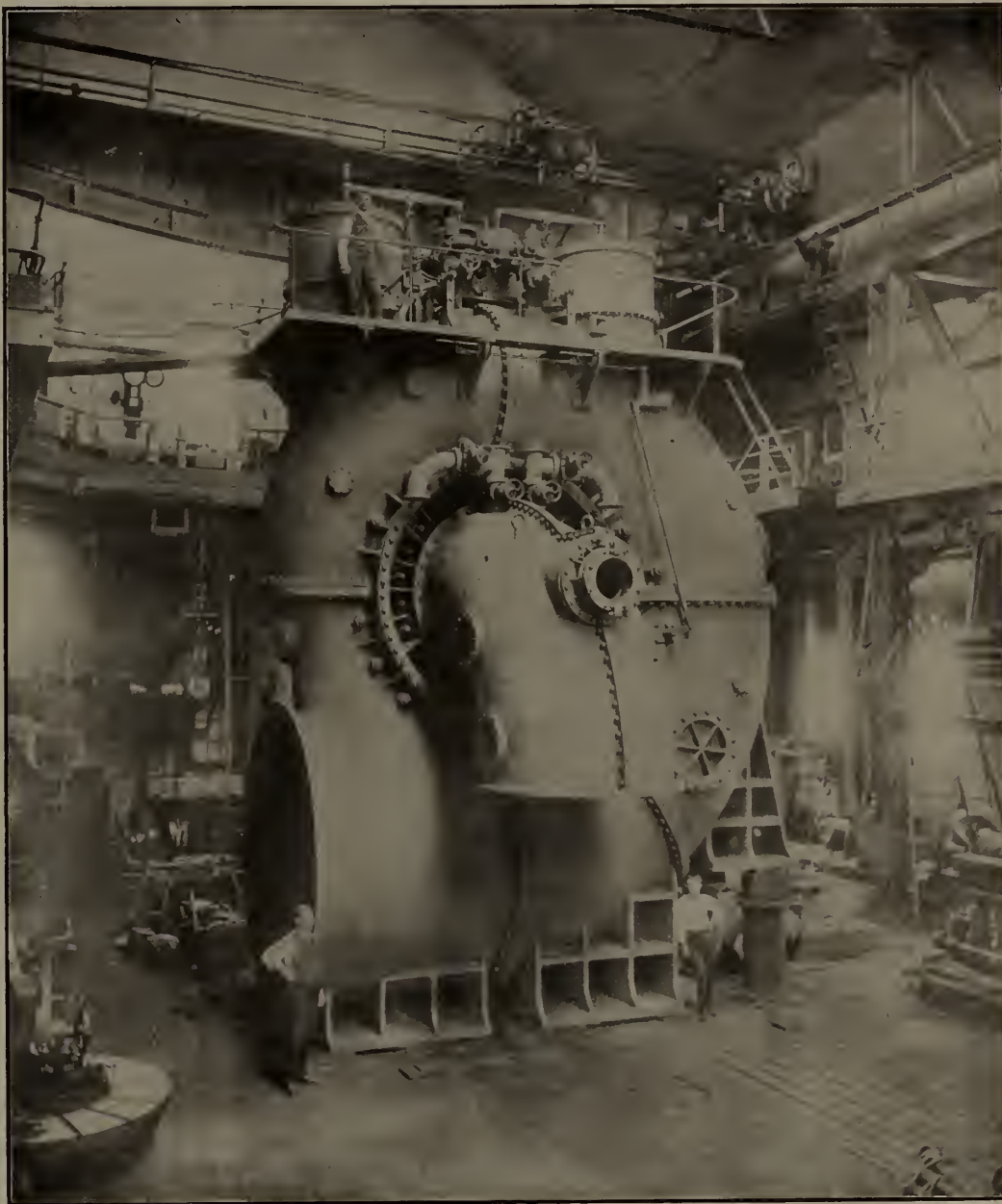

THE LARGEST WATER WHEEL EVER CONSTRUCTED—10,500 HORSE POWER.

staves or heading. Staves for tight cooperage are often stacked edge upward across the stack. A layer is placed full length of the stack, then a string of staves placed on each end of these, on edge, full length of stack; then more staves on edge, and so on indefinitely. This method has its good features, as well as those that are not so good. It exposes the ends, there being no lap to keep the end from drying. Edge stacking is desirable for beer stock, on which, being extra thick at the ends, lapping is quite objectionable. The edge-wise method is sure to put all the weight of the stock above on the broadest pieces, hence the stacks cannot be built very high, no matter how desirable it would be to economize floor space.

All these details, unimportant individually, become very important collectively. The little, unimportant items make, in the aggregate, the important whole. It is necessary for the man

Quebec, and which is the largest wheel that has ever been constructed. It is 30 feet from base to top; 22 feet wide; weighs 364,000 pounds; shaft is of forged steel, solid, 32 feet 3 1/2 inches long, 22 inches in diameter in center, tapering to 16 inches on the generator side and 10 inches on the other side; the distance from center to center of shaft bearings is 27 feet; the shaft weighs 10 tons; the runner is of bronze and weighs 5 tons; the intake is 10 feet diameter.

The wheel proper is intended to operate at a speed of 180 revolutions per minute, under a head of water varying from 125 to 135 feet. The quantity of water going through the turbine when developing the full power is 395,000 gallons per minute. Some idea of the quantity of water which this means may be gathered from the fact that it is equal to a river 88 feet wide and 10 feet deep, having a constant flow of 60 feet per minute.

LUMBER INSURANCE IN CANADA.

BOSTON, Jan. 25, 1905.

Editor CANADA LUMBERMAN:

Dear Sir,—The conditions affecting insurance contracts in Canada may account, in a measure, for the fact that companies insuring lumber risks in Canada make no money.

The record of the Lumber Mutual, for nine years completed record, shows a loss ratio to premiums of 80 per cent. As the company pays dividends of 33½ per cent., and its expense account, about one-third the average of the stock companies, has been reduced to 14.17 per cent., while the total cost of our Canadian insurance is 127½ per cent. on the premiums, you can readily understand we cannot continue this Canadian business under any such record of its costing us 27½ per cent. more than we get for it.

Canadian companies; one or two of which are owned largely by the lumber interests and operated, presumably, in the interest of the lumber trade, show the same unfortunate results on their underwriting. Assessment after assessment has to be called on their stockholders, as each previous assessment is used up, in order to keep their indemnity good to their policy holders.

I have noted two conditions in policies which, to my mind, have contributed in a measure to this result.

First, the condition as specified "full co-insurance" on lumber risks. Whether it is a mill on which full co-insurance is demanded as a condition of the contract, and the assured can recover the full value in event of a fire, or whether it is insurance on lumber stocks, where the assured is expected to carry insurance to full value—in either case the principle is wrong, the assured's interest in protecting the property is wanting.

On mill insurances, we have found prevailing in the south a clause entitled the "Three-fourths cash value clause," reading as follows:

"THREE-FOURTHS CASH VALUE CLAUSE.

It is understood and agreed to be a condition of this insurance, that in the event of loss or damage by fire to the property insured under this policy, this company shall not be liable for an amount greater than three-fourths of the actual cash value of each item of property insured by this policy (not exceeding the amount insured on each such item) at the time immediately preceding such loss or damage; and in the event of additional insurance—if any is permitted thereon—then this company shall be liable for its proportion only of three-fourths of such cash value of each item insured at the time of the fire, not exceeding the amount insured on each such item."

The object of this clause is to prevent the assured collecting, in the event of a fire, over three-fourths of the cash value of each item of the policy, and insuring as good care to prevent fires as his 25 per cent. interest in any total loss will secure. This principle should be applied to all mill insurances, and the same principle, in effect, should be applied to all lumber stock insurances, as will be later explained.

Our second most prolific cause of loss may be the stipulation that, as to the adjustment of loss, the market values of stock shall be the basis of the adjustment of the loss. That is, the insurance companies shall pay, in the event of a loss, just as much as a sale of the property in the open market would net at the location of the fire on the date it occurs. This principle is

companies carrying full insurance the most prompt and best paying customers for the stock held on a falling market.

To guard against this, we propose first, that the basis of the adjustment shall be the market value the stock would net to sell for at the location of the fire on the date thereof.

In sawing out a cut of logs, the stock varies in value according to the grade and kind of lumber, therefore the market value of each kind and grade is certainly the most fair basis for the adjustment, but the payment should never be in full of that value.

Our idea is that the insurance stipulated for should be only 70, 75 or 80 per cent. of the value, as may be agreed on, and correspondingly the payment should only be 70, 75 or 80 per cent. of the market value per M. feet in event of a fire.

I believe the adoption of this feature, as per the following clause, would tend in a measure to reduce the fire loss.

"LIMIT OF LIABILITY ON LUMBER.

In the event of fire loss the basis for adjustment shall be the net market value at which the lumber could be sold at the location on the date of the fire.

The liability of this company shall be limited to 80% of the said market value—1,000' for each grade and kind of stock destroyed.

In the event of additional insurance whether valid or not, this company's liability shall be limited to its proportion of 80% of the net market value—at which the lumber could be sold at the location on the date of the fire."

Again, another measure of protection should be inserted in all policies covering lumber stocks, in the nature of a "Location Clause," which we find universally applied in some sections and reading as follows:

"LOCATION CLAUSE APPLYING TO LUMBER.

Provided that whenever lumber covered by this policy shall be separated by spaces of 100 feet, this insurance shall apply specifically on each separate location, as the value of lumber in each location bears to the total value."

The object of this may be illustrated by the fact that on one occasion we found the Lumber Mutual insuring lumber "located on switch track leading from main line of railroad to mill."

We found this switch track about two miles and a half long. We found five separate and distinct piling grounds between the main line and the mill. We found the assured carrying \$10,000 insurance blanketed as above. By carefully keeping about the same value, \$10,000 or \$12,000 worth at each separate piling ground or yard, the assured was very sharply getting insurance on \$50,000 or \$60,000 worth of stock and being fully protected with \$10,000 insurance. In fact, he was protecting five distinct and separate risks for one premium.

This about equalled the proposition of the Wisconsin insurer who, on one occasion, divided his yard by a main thoroughfare three hundred feet wide between the piles, and then divided the piling sections into four separate spaces on each side of this main thoroughfare by 200 feet clear spaces, thus leaving 200 feet clear space one way and 300 feet the other, and by piling about \$25,000 worth of stock in each location or piling space and then insuring the lumber by a blanket form for \$25,000, he proposed to practically insure eight

distinct and separate risks aggregating \$200,000 value for one premium in \$25,000 value.

These are only illustrations of the chances the companies may take, except they protect themselves by proper clauses in policy contracts.

I am not suggesting that a majority, or any large proportion of the lumber trade, desire these advantages in their policy contracts, or are dishonest in any particular. We have found the claims for losses so far presented to the Lumber Mutual so fair that, in ten years, we have never had a reference in any case, as to any loss, and never contested but one loss, but when risks are taken at rates varying anywhere from 1½ per cent. to 6 per cent., it is readily understood that if only one policy holder in twenty or one policy in sixty might take advantage of the companies in this way and have losses, that the difference would be marked as between a successful insurance business and an unsuccessful one.

I think I may have explained why Canadian insurance in the lumber manufacturing districts is not profitable according to the experience of some Canadian companies whose records we have noted.

Anyone wanting policies of the Lumber Mutual Fire Insurance Company of Boston will have to allow us to insert such conditions of contract in the policies as will enable it to protect itself in the ways suggested from such unprofitable features as recited above, that it may continue to progressively increase its dividends now earned and paid at 33½ per cent. from ordinary stock company rates.

Yours truly,

W. C. JOHNSON, President.

LOOK FOR THE MAKER'S NAME OR TRADEMARK.

In all lines of merchandise, goods which have become well and favorably known are often imitated and sold to the consumers with the assurance that they are "just as good" as the articles which bear the maker's name or trademark, while as a matter of fact such goods are often "seconds" or goods of inferior quality, for which reason the maker will not show the name or trademark under which he has built up a valued reputation for quality.

Manufacturers usually make several grades of goods, and are careful that their best grades shall bear their name or trademark to advertise the excellence of their products, and it follows that they are not only willing but anxious to immediately replace any article so guaranteed to have been made by them and which may prove defective in any way. This is especially true with articles usually sold by hardware stores. It is a common practice with manufacturers of these lines to dispose of their inferior grades under what is known to the trade as "special brands," and also to furnish such goods to buyers of large quantities, marked with the buyer's "private brand"; needless to add that private brand goods, bought from whichever manufacturer will make the lowest price on a season's quantity, carry no assurance of quality, and it behooves the consumer who desires quality and manufacturer's guarantee to see that goods bear maker's name or trademark.

Uncle Sam would not allow his battleships to be babbitted with inferior babbitt metal. New Battleship "Nebraska" is lined with Syracuse Babbitt. Always specify best. It is cheapest in long run.

SYRACUSE SMELTING WORKS

MONTREAL

NEW YORK

SEATTLE

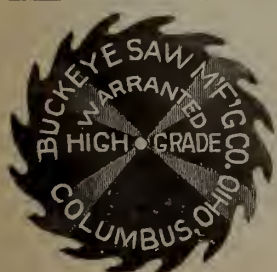
...BUCKEYE SAW M'FG. CO...
MANUFACTURERS OF

High-Grade Saws

Quick and careful work on Repairing.
All kinds of Mill Supplies.

REYNOLDS BROS., Proprietors
267 N. Water Street, COLUMBUS OHIO.

CANADIAN OIL CO. LIMITED

STRACHAN AVENUE TORONTO, ONT.

TO LUMBERMEN THE DOMINION OVER:

OUR TRADE WITH SAW-MILLS

Has been large and satisfactory. We again solicit your orders for the season of 1905.

Our Agents will call with "STERLING"

Cylinder, Engine, Dynamo, Machine, and SPECIALTY Oils, Greases, Packing, Waste, Babbitt Metal, Ready Mixed House Paints, Varnish, Red and Black Roof Paint, Smoke Stack Black for Boiler Fronts and Saw Mill Refuse Burners, White Lead, etc.

BRANCHES: Petrolia, Ont. Hamilton, Ont. Montreal, P. Q. Vancouver, B.C.
London, Ont. "Soo," Ont. Winnipeg, Man. St John, N. B.
Halifax, N. S.

'STERLING'
OIL

'STERLING'
OIL

CANADA LUMBERMAN

AND WOOD-WORKER

WEEKLY EDITION

The Lumberman Monthly Edition, 44 pages} \$1.00 PER YEAR {The Lumberman Weekly Edition, every week.

THIS PAPER REACHES REGULARLY THE PRINCIPAL LUMBER MANUFACTURERS AND DEALERS THROUGHOUT CANADA, AND WHOLESALE BUYERS IN GREAT BRITAIN, THE UNITED STATES, AND OTHER FOREIGN MARKETS.

VOL. XIII.

TORONTO, MONTREAL, WINNIPEG, MARCH 1, 1905

No. 5

CANADA LUMBERMAN

PUBLISHED BY

The G. H. Mortimer Publishing Co'y
of Toronto, Limited

Confederation Life Building - TORONTO.

Branch Offices:

38 ALLIANCE BUILDING, MONTREAL
720-721 UNION BANK BUILDING, WINNIPEG.
22 GREAT ST. HELEN'S, LONDON, E. C.

The Weekly Lumberman—Published every Wednesday, contains reliable and up-to-date reports of market conditions and tendencies in the principal manufacturing districts and leading domestic and foreign wholesale markets. A weekly medium of information and communication between Canadian timber and lumber manufacturers and exporters and the purchasers of timber products at home and abroad.

The Monthly Lumberman—A 44-page journal, discussing fully and impartially subjects pertinent to the lumber and wood-working industries.

WANTED AND FOR SALE

Advertisements will be inserted in this department at the rate of 15 cents per line each insertion. When four or more consecutive insertions are ordered a discount of 25 per cent. will be allowed. This notice shows the width of the line and is set in Nonpareil type; 12 lines make one inch. Advertisements must be received not later than 4 o'clock p. m. on Tuesday to insure insertion in the current week's issue.

EXCELSIOR WOOD WANTED—PEELED basswood or clear spruce. RANKIN AND Co., Dundas street, Toronto. Telephone.

WANTED—A MAN TO TAKE CHARGE OF a planing mill. Must be competent to figure on work and get it out at a profit. Address MANITOU LUMBER CO., North Bay, Ont.

FOR SALE—1", 6/4", 2" SOFT ELM. 1", 2", 3", Birch. 1" Wormy Chestnut. 1", 6/4", 2", 3", 4" Hard and Soft Maple, 1", 6/4", 2" Beech 1", 2", 3" White Ash. 1", 2", 3", 4" Red and White Oak. Cedar Squares. R. E. KINSMAN, Hamilton.

WANTED—POSITION BY FOREMAN millwright 30 years of age, married. Thoroughly conversant with the erection and operation of modern saw mill machinery. All references. Address Box 195, CANADA LUMBERMAN, Toronto, Ont.

WANTED

Party with timber limits to form Company with a party who has a modern saw mill plant, capacity twenty million, on North Shore Georgian Bay. Address Box 193, CANADA LUMBERMAN, Toronto, Ont.

FOR SALE

2,500,000	Laths	1 1/2	Red Pine Mill Run
1,500,000	"	1 1/4	White Pine No. 2
70,000	feet	1	Good Spruce
150,000	"	1	Pine 2d qua. shorts 6/11
230,000	"	1	" 2d qua. strips 12/16
700,000	"	1	" S.C. shorts 6/11
400,000	"	1	" S.C. strips 12/16
18,000	"	1 1/2	Cut up sidings 12/16
30,000	"	1 1/2	Cut up sidings 12/16
21,000	"	1	Good Sidings 12/16

Apply to H. BOURGOIN, 71A St. James street, Montreal, P.Q.

WANTED—UP TO DATE BAND SAW filer for hard wood mill, state salary expected. Address D. CONKLIN, Kingsville, Ont.

FOR SALE.

LUMBER AND SAW-MILL BUSINESS ON C. P. R. Main line. Mill in good running order. Daily sawing 20 to 25 M feet. Timber convenient to mill. Address A.B.C., CANADA LUMBERMAN.

LUMBER YARD FOR SALE

RETAIL YARD AT DARLINGFORD, MANITOBA, annual turnover about 30 car loads. Progressive growing town. First class farming country surrounding. No opposition in town. About \$5,000 stock on hand in good condition, and good office and lumber shed. Correspondence solicited. J. H. BOLTON, Darlingford, Manitoba.

FOR SALE.—SAW MILL MACHINERY, nearly new. Capacity 15,000 ft., 100 M feet hardwood logs, 300 M feet hemlock logs, three million feet hemlock and hardwood timber, 1,000 cords bark, 30,000 cords wood. Complete logging outfit, quantity shingle bolts at mill and in bush. No dues. Close to G.T.R. Good timber locality. Reason for selling, failing health. For price and terms apply to Box 194, CANADA LUMBERMAN, Toronto, Ont.

FOR SALE

An all year Water-Power Saw and Shingle Mill Plant, 120 ft. Head if required, 33 ft. in use, with capacity of 25,000 ft. per day. 3,500 acres, estimated 2 1/2 million Green Pine and Hemlock, Cedar Timber for 50,000 R.R. Ties, 500,000 to 800,000 posts, 12 to 15 million Shingles, 200 M. Spruce and Tamarack, 500 acres Hardwood close to mill and Georgian Bay, 55 miles from Owen Sound, North West.

A lake 2 1/2 miles long is water supply and means of conveying logs into mill, other advantages. Mill and docks on Georgian Bay. Price and reasons for selling on application to ROBERT LYMBURNER, Dyers Bay, Bruce County, Ont., or care of HORACE LYMBURNER, Owen Sound, Ont.

THE LOCATORS.—W. B. Herbert, General Manager. The largest and oldest exclusive Business Brokers in the West. Address, THE LOCATORS, 63 Merchants' Bank Building, Winnipeg.

Lumber and Coal.—E. 41. Do you want a business that will give you a good living and clear you Two Thousand a year. This is it. The location is a good one and the town and the country A1. Write us for further particulars. THE LOCATORS.

Lumber—E. 40. Seven Thousand handles this high-class lumber business clearing Eighteen Hundred yearly. Has exclusive agency for a good line of coal. THE LOCATORS.

Lumber, Flour and Feed and Coal—This unique business can be purchased for Four Hundred and it is a Snap, no competition. If you write us we will give you further particulars about it and they will interest you if you have a small capital and wish to start in business. THE LOCATORS.

Timber Limit—In B. C., containing eight square miles of good Cedar, Fir, Pine and Spruce. This An A1 money making limit. We have had the opinion of an expert who has been through it and are well satisfied with his report. Price Twenty Five Thousand, half cash. Balance annually. THE LOCATORS.

Saw Mill—In Western Ontario, with all necessary machinery for matching and making lumber. Store in connection, navigable stream running by station. This is a Snap at the price asked, Thirty Seven Hundred, and will make you easy terms. Enquire about this at once. THE LOCATORS.

Saw Mill in Alberta—Including blacksmith shop, three quarters section of timber land containing five million feet. Mill has all machinery needed and turns out two million feet annually. Price Six Thousand Six Hundred and we will make you easy terms. THE LOCATORS.

Our new book is about ready and we would like you to send for a copy. Address THE LOCATORS, 63 Merchants' Bank Building, Winnipeg.

WANTED—ALL PULP MILLS AND PULP-WOOD Companies to look up page 7, monthly issue, which is bound to interest you.

FOR SALE

ONE "BOSS" POWER SHINGLE MACHINE. Four Drake hand shingle machines. Apply G. B., care CANADA LUMBERMAN, Toronto.

WANTED, 300,000 FEET WINTER CUT Basswood, Common and Better in quality, 1 1/16" thick when dry. Address: Box 189, care of CANADA LUMBERMAN.

WANTED—TEN THOUSAND CORDS Hard and Soft Wood; also same quantity of Slabs. SIMCOE WOOD AND LUMBER CO., 52 Yonge Street Arcade, Toronto.

FOR SALE.—FIFTY ACRES OF UN-culled good hardwood timber. Beech, birch maple, and basswood.—Address Box 197, CANADA LUMBERMAN, Toronto, Ont.

WANTED AT ONCE, SWING SHINGLE Machine, suitable for cutting shingles or heading. Give full description with lowest cash price. Apply H. CARGILL & SON, Cargill, Ont.

WANTED—POSITION BY EXPERIENCED lumberman as manager or salesman of saw-mill operations, familiar with Canadian and United States market. Box 198C ANADA LUMBERMAN, Toronto, Ont.

HAVE YOU ANY STOCK WHICH YOU wish to sell? If so, make the fact known to probable buyers by placing an advertisement in the Wanted and For Sale Department. Address, CANADA LUMBERMAN, Toronto.

OAK FOR SALE.

A QUANTITY OF WHITE WHICH I CAN cut in ship bills or other construction work; also a considerable quantity of piling and other hardwood timber. JOHN HAYNE, Bridgen, Ont.

FOR SALE AT PEMBROKE.—2 PAIR Waterous oscillating twin engines, suitable for rope or steel cable; 1 Waterous lath mill and bolter; 160 ft. heavy conveyor chain with sprocket wheels and bunks. All the foregoing in good condition. Will be sold cheap. Write for particulars.—THE PEMBROKE LUMBER CO., Pembroke.

FOR SALE.

SAW MILL, 40 HORSE RETURN TUBULAR boiler, good as new, with stack, front, injector, etc.; 30 horse power engine; 50 inch saw with carriage; shafting, belting, shingle machine, lath machine, pair frame set of chopping stones. Will put on cars if necessary at Courtland; price \$400. Can be seen running any time within one month. BENJAMIN MABEE, Mabee P.O., Ont.

FOR SALE.

397,000 feet 2" x 4" and up, Norway Lumber, Log Run.
86,000 feet 1" x 4" and up, Norway Lumber, Log Run.
43,000 feet Mill Culls, etc.
Also the product of two million feet good white pine logs to be cut next summer. Correspondence solicited.

PINE LUMBER COMPANY, Pine, Ont. (near Cartier.)

CANADIAN TUGS FOR CHARTER FOR SEASON 1905

Tug Florence—Engine fore and aft compound 18 1/2" x 36" x 26. Large Scotch Boiler 12 1/2" x 11 1/2" and easy steamer.
Tug Home Rule—Engine High Pressure 22 1/2" x 24". Fire Box Boiler 8' x 14'.
Tug Christian, S.J., (American)—Engine High Pressure 19" x 20". Fire Box Boiler 6 1/2' x 12'.
For further information address HACKETT TUG LINE, Amherstburg, Ont.

FOR SALE—25 H.P. HORIZONTAL ENGINE. Second-hand, in good running order. Very cheap. Address ALFRED RUBBRA, 22-24 Victoria Square, Montreal.

FOR SALE—NEW SAW MILL CARRIAGE and Frame, for immediate shipment. Price low. Address ALFRED RUBBRA, 22-24 Victoria Square, Montreal.

CEDAR FOR SALE

10,000 PIECES ROUND CEDAR, 8-16 AND 25 feet long, on the Vermillion river. Can be delivered at Spanish boom. Also Cedar, Pine and Spruce lumber for sale here at Larchwood on C. P. R. JAMES MCCREARY.

CURRENT TRADE CONDITIONS.

ONTARIO.

There is plainly evident a disposition to buy lumber to meet near-by requirements. The hope of a decline in prices has, it appears, been abandoned, and consumers are now willing to consider quotations which two months ago were quickly turned down. The business community generally are looking forward to a year of prosperity in all branches of industry, and under such conditions lumber prices are certain to be sustained. Overproduction could easily bring about a reaction in values, but nothing approaching overproduction has occurred; in fact, operations in the woods this winter have been unusually light, due to conditions previously mentioned.

Considerable lumber is changing hands. Dealers report orders on their books to keep them busy for some time, and more business would doubtless be placed but for the uncertainty of delivery owing to snow blockades. Disputes with the railways are numerous, and as these often involve increased charges, the buyer of lumber prefers to wait until conditions are more favorable for getting his stock when wanted.

The first sale of square pine this season has been recorded, J. Burstall & Company, of Quebec, securing the Madawaska production by J. R. Booth. The price is said to correspond closely to last year's figures.

QUEBEC AND NEW BRUNSWICK.

The lumber trade of the Eastern Provinces is at a very low ebb, due to the stormy weather which has been experienced. The railroads have been completely tied up, making shipments by rail an impossibility. The deep snow has also interfered with logging operations, which have been abandoned in some districts. These conditions, while exerting a temporary unfavorable effect upon the market, will mean increased activity in the spring. All indications point in the direction of higher prices for both British and United States specifications. New Brunswick cedar shingles are exception-

ally quiet and sales of Extras continue to be made at \$3.20 for Boston delivery. Lath are in relatively strong demand.

UNITED STATES.

All the lumber producing districts of the United States have now fallen into line with the stronger tone. The Pacific Coast situation has been improved by the advance put into effect by the Pacific Coast Lumber Manufacturers' Association, and while the advance will not average above 50 cents a thousand, it is decidedly reassuring as showing the changed attitude of the trade. Southern pine is very strong. Conditions for logging throughout the yellow pine states were unfavorable during January and February, and the mills will not have a large stock of logs, so that prices are likely to continue firm throughout the season. The strength of yellow pine is aiding the sale of white pine, which is moving in moderate volume. The largest single transaction so far this season took place last week at Duluth. Manufacturers are asking higher prices on low grade stock, the supply of which is none too plentiful.

The improvement in the hardwood trade has been maintained. In Michigan prices are about \$15 for maple, \$18 for birch and \$20 for basswood at the mill. The hardwood production of Michigan last year showed a considerable expansion, and the fact that prices did not decline to any extent is doubtless due to an increased consumption. The supply of ash appears to be getting smaller, inch being in good demand. Birch is quite active and is being purchased in large blocks by consuming industries.

During the past two weeks there has been some accumulation of white pine lath, but up to the present prices have not weakened. Shingles are reported to be a little firmer, although prices are irregular and no general advance has taken place.

GREAT BRITAIN.

While conditions in Great Britain are undoubtedly on the mend, the timber trade does not appear to have realized the full benefit of the general improvement in other branches of industry. The demand is still a little slow. A revival in the building trade would greatly strengthen

the situation and induce more ready buying of lumber. Representatives of Canadian shippers are now in England, but have not been able, so far as can be learned, to close many contracts. On the other hand, however, the market is firm, and merchants holding either pine or spruce deals are disposed to wait for a further recovery in the market before disposing of them. At Liverpool there is a scarcity of 3x7 inch, which size is used in large quantities for new cotton mills. The price now asked is £7 a standard, whereas two months ago dealers were willing to accept £6 5s. The large reduction in spruce stocks generally has encouraged the dealers to endeavor to recoup some of the losses of last year. A small stock of spruce containing 70 per cent. narrows, and the balance 9 inch and up, was recently sold at £6 17s. 6d. c.i.f. Liverpool. For pine higher prices are also being asked. Cox, Long & Company, of London, recently issued a stock sheet quoting some first quality pine, running up to 4 by 33 in., at £48 per standard.

STOCKS AND PRICES.

R. Lockhart, of Gash Point, Ont., has already cut over two million feet of logs this winter.

S. O. Fisher, of Bay City, has sold ten million feet of lumber cut at Blind River, Ont., to Buffalo and Toledo parties.

The British Columbia Electric Railway Company are taking tenders for the supply of eight thousand fir ties.

The Inglewood Pulp & Paper Company, of Musquash, N.B., have eleven camps in operation this winter and expect to get out about 15,000,000 feet of logs.

R. R. Dobell & Company, of Quebec and London, have secured the Admiralty contract for the supply of Canadian timber and deals during 1905. This contract amounts to approximately \$175,000 in value.

It is estimated that the Gibson Railway & Manufacturing Company, of Marysville, N.B., will cut 20,000,000 feet of logs this winter. At present there is four feet of snow on the Nashwaak headwaters.

The largest sale of the year of lumber to

be cut in the Lake Superior district during the coming season was made last week by the Tower Lumber Company. The transfer consists of 35,000,000 feet, 90 per cent. of which is norway.

The Spanish River Lumber Company are not logging on the Georgian Bay this winter. They had about five million feet of logs held over from last year, which will be manufactured at the Spanish River mill of the Huron Lumber Company.

The Crown Lands Department of New Brunswick are asking for tenders up to Wednesday, March 8th, for a license to cut timber on two square miles on the Maguadavic river at Brockway, for which Robert Vail is the applicant. The upset price is \$20 per square mile.

Statements issued by the secretaries of the Mississippi and Wisconsin Valley Lumbermen's Associations show that during January of this year the shipments of white pine lumber were 105,000,000 feet, as compared with 79,000,000 feet for the corresponding month in 1904.

It is reported that the Victoria Lumber & Manufacturing Company, of Chemainus, B.C., have secured contracts for supplying thirty million feet of lumber to points in the Northwest Territories during the present year. The Chemainus mills have on hand a large number of logs, and, with their foreign trade, will be kept busy this season.

The following prices were realized at an auction sale held by Foy, Morgan & Company, London, England, on February 15th: Pine—12-16 ft. 2x15-22 in. 1st quality dry, £27 15s. per standard of 1,980 ft.; 12-18 ft. 3x9 in. second quality red., £11. Spruce—12 ft. 3x8 in. unassorted, £8; 12 ft. 3x7 in., £7 15s.; 14-17 ft. 3x7 in., £7 15s.; 9-11 ft. 3x7 in.,

£7 10s. Elm Timber—15¼ x 18¾ in., 31 to 35 ft., 64s. per load of 50 cubic ft.; 15½ x 21¼ in., 31 to 34 ft., 64s.; 15¾ x 18½

W. C. CRAWFORD

Tilbury, Ont. Manufacturer of

Handles—Axe, Fork, Pick, Etc.

Also Hard and Soft Wood Heading, and Red and White Oak, Maple and Elm Lumber.

Can supply Second Growth White or Red Oak squares up to 38 in. long in large quantities.

THE KING AND BARTLES LUMBER CO.

PINE, POPLAR AND HARDWOODS

HEADQUARTERS Citizens' Building, Cleveland, O. HARDWOOD Distributing Yard McMinnville, Tenn.

We buy and sell Pine in Car and Cargo Lots

JOHN P. NEWMAN

Manufacturer and Wholesale Dealer Lumber, Square Timber, Shingles, Posts, Etc.

Warton - Ontario

Write for quotations on 1" Maple, 3" and 4x4 Cedar, 1" Birch and 3x Cedar Shingles.

M. & L. Samuel, Benjamin & Co.

203 Temple Building, Toronto.

EXPORT DEPARTMENT.

Correspondence solicited with exporters of wooden goods, such as Sanitary Woodenware, Broom Handles, Fork and Shovel Handles, Turned Goods, etc. Payments made on receipt of Bill of Lading at Toronto. European House, SAMUEL SONS & BENJAMIN, 16 Philpot Lane, London, Eng.

McLennan Timber Land and Lumber Co., Limited

Selling Agency and Dealers in all kinds of Timber Lands.

Offices: Quebec, 131 St. Peter St. Ottawa, Room 9, Central Chambers.

Herman H. Hettler Lumber Company

Manufacturers and Wholesalers of . .

WHITE and NORWAY PINE LUMBER LATH and SHINGLES

Shipments by Rail or Water

MIDLAND, ONT.

WOODS & SPICER, Limited

.....MANUFACTURERS OF.....

BRITISH COLUMBIA RED CEDAR SHINGLES

Capacity 100 Million a Year.

We have had over 15 Years Experience, and are not Asking our Competitors for any Pointers as to Quality.

Wire Your Orders at OUR EXPENSE to Agents, or to us at VANCOUVER, B. C.

KNIGHT BROTHERS CO. Burk's Falls, Ont.

KILN-DRIED BIRCH FLOORING

Send for Catalogue & Samples by Mail

KNIGHT BROTHERS CO. Burk's Falls.

Keenan Bros., Limited

Owen Sound, Ont.

HARDWOOD, HEMLOCK AND PINE LUMBER

We carry a full supply of native Hardwoods always on hand and solicit your inquiries. At the present time we have piled at outside points about 2,000,000 feet of Hardwoods, and about the same quantity of Hardwood, Hemlock and Pine piled here in Owen Sound, and we should be able to interest you if in the market.

WILL MAKE SPECIAL PRICES ON BROKEN LOTS AT OUTSIDE POINTS

ORILLIA PLANING MILL

Near G.T.R. Station

PLANING, MOULDINGS, MATCHING, FLOORING, RESAWING, SIDING

Done any quantity. Write for price.

S. POMEROY, Phone 311

MASON, GORDON & CO.

WHOLESALE TIMBER

Montreal, Quebec

Eastern Agents The B. C. Mills, Timber & Trading Co., Vancouver, B. C.

DOUGLAS FIR Timber in any size or length supplied WRITE FOR PARTICULARS AND QUOTATIONS.

EVERYTHING IN LUMBER AND TIMBER

DRESSED AND IN THE ROUGH

BULMER, McLENNAN & COMPANY

MONTREAL, QUE.

Office and Yard, 571 DORCHESTER ST.

P. O. Box 116

in., 30 to 33 ft., 67s.; 15 1/4 x 25 3/4 in., 25 to 30 ft., 67s.; 15 1/2 x 19 1/4 in., 26 to 28 ft., 65s.

The Pacific Coast Lumber Manufacturers' Association decided at their last regular meeting to make a general advance in prices. No. 1 and No. 2 5-8 fir ceiling and No. 1 and No. 2 fir drop siding were advanced \$1 per 1,000 feet and all 6-inch fir ceiling was made \$1 higher than 4-inch. Lath was advanced 25 cents per 1,000 and advances were made in 1 x 4 and 1 x 6 common boards and fencing, shiplap, fir joists and scantlings and timbers, s i s i e, and cedar siding. Many of the items in the list were not changed. With the exception of lath, which were advanced 25 cents per 1,000 pieces, the changes were an advance of from 50 cents to \$1 per 1,000 feet, so that on the whole there was an aggregate advance of about 50 cents.

COOPERAGE STOCK PRICES.

Barrel and Box, of Louisville, Ky., quotes the following prices on cooperage stock f.o.b. Buffalo in car load lots:

SLACK STOCK.

Staves—No. 1 elm flour barrel, \$9.50 to \$10.00; No. 2 elm barrel, \$7.50 to \$8.00; mill run fruit barrel, \$8.00 to \$8.50; mill run hardwood staves, \$7.50 to \$8.00. Heading—No. 1 basswood, 6 1/2 c to 6 3/4 c; No. 2 basswood, 4 3/4 c to 5 1/4 c; mill run hardwood, 5 1/2 c to 6c.

Hoops—Elm, 6-ft., \$9.00 to \$9.50; elm, 5 1/2-ft., \$8.50 to \$9.00; hickory, shaved, \$6.25 to \$6.75.

TIGHT STOCK.

Staves—Pork, \$26.50; whiskey, 34 or 35 x 7/8, \$64.00; whiskey, 34 x 3/4, \$54.00; oils, \$34.00; sawed wine, 34 x 3/4, \$51. Heading—Pork, 17c to 19c; beer, halves, 32c; beer, quarters, 22c] Hoops—Tierce, \$13.00 to \$14.00; poik, \$10.00 to \$11.00.

HARDWOODS.

Of the hardwood market the Mississippi Valley Lumberman says: "The actual movement of hardwood has been practically at a standstill during the past week. Snow blockades have seriously interfered with the car supply and considerable stock which was in transit has been delayed many days beyond all calculations. A temporary lull has come over the market, and while ordinarily there is nothing brisk at this time of the year, the conditions have been aggravated by the widespread storms and cold. The factory demand is still the life of this market. It has been steady in volume since the first of the year and shows a decided tendency to increase with the year. Demand for all factory products has been steadily growing and factories have been meeting this with more extended operations. Their stocks were low at the opening of the year and this has compelled them to purchase somewhat more

briskly in the market. The country yard trade shows some life. Orders for mixed cars with the usual proportion of hardwood items are becoming more frequent. The snow storms have interfered with shipments but the orders continue to come and every indication, at present, points to an early spring demand from the country. Flooring is in good demand in the cities and considerable of this stock is moving. Prices are holding closely to the list on flooring and there are no surplus stocks seeking purchasers. The oaks are in steady demand but the supply seems to be better than it was a year ago and during the earlier part of last summer. Basswood is stronger than it has been for many months and during the last week some good sales of this lumber were reported at prices considerably higher than a year ago."

The mill of the McRae Lumber Company at Hosmer, B.C., has been sold by the Sheriff to F. J. Watson, who is understood to be acting for a client. The price was \$7,700, although the mill complete cost in the neighborhood of \$15,000.

L. M. Shepard, doing a wholesale lumber business in Boston under the style of Shepard, Farmer & Company, is announced to have filed a voluntary petition in bankruptcy. His schedule shows liabilities of \$156,604, of which \$79,403 is unsecured and distributed among about 125 creditors. Mr. Shepard was formerly

a member of the Shepard & Morse Lumber Company, but withdrew from that company to engage in business with William T. Farmer, formerly of the Wood-Barker Company. Mr. Farmer died not long after the partnership was formed.

L. Dean Holden, Pres. J. M. Diver, Gen'l. Mgr. A. F. Holden, Vice-Pres. E. C. Barre, Ass't Mgr.

The Cleveland-Sarnia Saw Mills Co., Limited.

Manufacturers and Wholesale Dealers In

Timber, Lumber, Lath and White Pine Shingles

Special Bills Cut to Order in White Pine, Norway and Fir, any length from 10' to 60' long.

—SARNIA, ONT.

J. B. Farwell & Son
.. CONTRACTORS AND DEALERS IN ..

Canadian Cedar Telegraph, Telephone and Electric Light Poles

Orillia, Ont., and Oswego, N.Y.

ROBERT WATT
WIARTON, ONT.

Manufacturer and Dealer in Hard and Soft Wood Lumber, Lath, Shingles, Cedar Posts and Ties.

SPECIAL: One car load of 3x4 Hardwood Hearts suitable for car stakes. One car of 3" Cedar Plank. One car each of XXXX and XXX Cedar Shingles. One half car each of XX and X Cedar shingles. Prices on application.

C. S. POWELL & CO.
Lumber Exporters

604 Temple Bldg., TORONTO and at NEW ORLEANS, LA.

To Millmen Cash buyers all kinds hardwoods. We solicit correspondence . . .

THE IMPERIAL LUMBER CO., LIMITED
SAW AND PLANING MILLS, WARREN, ONT.
RED AND WHITE PINE DEALS
All kinds of **SAWN LUMBER**
By Carload or Cargo.
Registered Cable Address, "Pinewood." "American Lumberman" Telecode.
BRANCH OFFICE, MANCHESTER, ENG.
Head Office, TORONTO, CAN.

SAGINAW LUMBER & SALT CO.
MANUFACTURERS OF
LUMBER AND SALT
Mills at Sandwich, Ont.
R. H. ROYS, Pres.
RALPH LOVELAND, Vice-Pres.
C. A. KENT, Sec'y.
R. S. ABBOTT, Treas.
SAGINAW, MICH.

For Quick Shipment

- 900 cords dry Hemlock Slabs.
- 2 cars 5/4 Spruce.
- 3 " 4/4 "
- 1 " 5/4 and 6/4 W. Pine, Mill Run, (good)



J. D. SINCLAIR
Vancouver Cedar Mills
VANCOUVER
B.C.

FOR
High Grade Cedar

THE MENZ LUMBER COMPANY

Manufacturers and Wholesalers
BRITISH COLUMBIA FIR, SPRUCE AND CEDAR LUMBER, RED CEDAR SHINGLES

We Solicit Your Inquiries.
J. F. FOSS, Manager. 624-625 Union Bank, Winnipeg, Man.

CEDAR LUMBER AND POLES FOR SALE

I can saw out to your order, during the winter months, bills in heavy square Cedar, or Planks. Have also for sale a few cars of Poles from 25 to 50 ft. Correspondence Solicited.

J. S. FINDLAY, OWEN SOUND, ONT.

J. D. SHIER LUMBER CO., LIMITED
BRACEBRIDGE, ONT.
MANUFACTURERS OF
LUMBER, LATH AND SHINGLES
Pine, Hardwood and Hemlock Floorings and Ceilings. Sash and Doors, Wood Turnings etc. All Dressed Lumber Kiln Dried if desired End Matched Flooring a Specialty.
GOOD PINE SIDINGS A SPECIALTY

Planing, Matching, Resawing, etc. in Car Lots.
Manufacturer of
Doors, Sash, Mouldings, Ceilings
End-Matched and Bored **HARDWOOD FLOORING**
ASPECIALTY.
Lumber Kiln Dried in Any Quantity.
J. R. EATON - Orillia, Ont.
Correspondence Solicited. Phone No. 54.

THE CHARLEMAGNE & LAC OUAUREAU LUMBER CO., LIMITED
404 Coristine Building,
MONTREAL, P. Q.
Mills at Charlemagne and Montcalm on Great Northern Railway.

SAWN AND DRESSED
LUMBER
Clapboards, Shingles, Laths, Butter Boxes
Write us for quotations. Shipments by rail or water.

CACHE BAY LUMBER INDUSTRIES.
Geo. Gordon & Co.,
Manufacturers of RED and WHITE PINE
Band - Gang **LUMBER**
Circular **L AND LATH**
CACHE BAY, Ont.
C. P. R. 26 miles West North Bay

CACHE BAY PLANING MILL CO.
... MANUFACTURERS OF ...
CROSS ARMS MOULDINGS
CROSS ARMS CEILING
FLOORING
WAINSCOTING
SHEETING
All kinds of Dressed and Pine Lumber.

Cedar Cove Mill,
Vancouver, B.C.

E. H. HEAPS & CO.,
Vancouver, B. C.

Ruskin Mill
Ruskin, B. C.

Lumber, Lath, Shingles, Doors, Mouldings, Etc.

SPECIALTIES :

AA1 HIGH GRADE CEDAR SHINGLES.

Cedar Bevelled Siding, Cedar Door and Sash Stock, cut to size, Cedar Finish, Base, Casing, Newels
Balusters, etc. Douglas Fir Timber up to 85 feet in length.

W. J. SHEPPARD PRESIDENT
Waubaushe, Ont.

J. G. SCOTT, GENERAL MANAGER
Vancouver, B.C.

Pacific Coast Lumber Co.

LIMITED

VANCOUVER, B.C.

MANUFACTURERS OF

**Fir, Cedar and Spruce Lumber, Lath, Mouldings, Turned Work, Etc.
High Grade Red Cedar Shingles**

Ontario Representative, W. J. LOVERING,

112 Mail Building, TORONTO

D. C. CAMERON, President and Manager.

WM. ROBERTSON, Secretary.

J. E. YOUNG, Cashier

The Rat Portage Lumber Co., Ltd.

Manufacturers
of

**White and Red Pine Lumber, Lath, Shingles, Sash,
Doors, Turned and Band Saw Work**

Dealers in CEDAR POSTS, POLES and TAMARAC PILING

Mills at RAT PORTAGE and RAINY RIVER, Ontario, WINNIPEG, Manitoba, and VANCOUVER, British Columbia, Head Office: RAT POTRAGE, Ontario

Our Vancouver Mill cuts High-Grade Cedar, Fir, Spruce and Red Cedar Shingles. Winnipeg Mills cut Pine, Tamarac and Spruce Lumber
We also Manufacture all kinds of Mouldings, Sash, Doors, Turned Worked and Boxes. Correspondence solicited at all four points.

THOS. KIRKPATRICK,

MANUFACTURER OF

 **Red Cedar Shingles**

Daily Capacity, 250,000 Mills at Hastings and New Westminster

Head Office: Hastings, B.C.

Orders Solicited and Correspondence Promptly Attended to. Telephone B 1425
Ontario Representative: W. J. SMITH, Fergus.

Export Lumber & Shingle Co.

Wholesale Dealers Limited

British Columbia Lumber and Shingles

The management of this company have had a lengthy experience in manufacturing and selling British Columbia Lumber and Shingles in Canada and the United States, and are well informed as to the requirements of the trade in those sections.

We are in a position to make prompt shipments at current market prices.

Correspondence and inquiries for prices and other information regarding British Columbia lumber conditions promptly answered.

YOUR TRADE RESPECTFULLY SOLICITED

VANCOUVER - BRITISH COLUMBIA

COOKE & TAIT

MANUFACTURERS OF ALL KINDS OF

B. C. FIR AND CEDAR LUMBER AND SHINGLES

Saw Mill, Planing Mill and Shingle Mill: False Creek, Vancouver, B.C.

WRITE FOR PRICES.

Hazelmere Lumber Co.

HAZELMERE, B. C.

MANUFACTURERS OF

FIR, CEDAR and SPRUCE LUMBER

CLEAR CEDAR AND FLOORING

Our Specialty.

Long Distance Telephone.

W. C. WELLS

PALLISER, B. C.

Manufacturer of

**High Grade Spruce, Fir, Cedar
and Lumber of all Descriptions.**

CORRESPONDENCE SOLICITED.

CANADIAN MANUFACTURERS and WHOLESALERS

THE PEMBROKE LUMBER CO.
PEMBROKE, ONT.

We make a specialty of Dimension Stock in Pine, Spruce and Hemlock, and solicit your enquiries.

DELAPLANTE - McBURNEY LUMBER CO.,
WHOLESALE

White Pine, Hemlock, Lath, Shingles

Stocks in Ontario at { Collingwood Midland Powassan Whitney Cartier Sturgeon Falls Callander North Bay

TORONTO OFFICE: Room 503 Manning Chambers.

Office, Yards and Docks, NORTH TONAWANDA, N. Y. Send us your enquiries

FOR Pine, Hemlock, or Hardwood, Lumber and Timber, Telegraph Poles, Ties, Posts, Lath, Shingles, Dressed Lumber, Sash, Doors, Interior Finish, End Matched and Bored Hardwood Flooring, etc., try

JOHN HARRISON & SONS COMPANY, LIMITED

We have a complete stock, two Saw Mills running in summer and one all winter.

HEAD OFFICE. SAW AND PLANING MILLS, OWEN SOUND, ONT.

RHODES, CURRY & CO., Limited
LUMBER MERCHANTS.

Yards at Amherst, Little Forks, Sydney and Halifax.

BUILDING MATERIAL of all kinds carried in stock. We are buyers of Ontario Basswood, Elm and Pine.

Amherst, N.S.

Sawn and Hewn Spruce, Hemlock, Pine and Birch Timber, Spruce and Pine Boards and Plank, Birch and Ash Boards and Plank, Flooring, Shingles, etc.

JAMES J. MURPHY, Bank of Hochelaga Building QUEBEC

The Cook & Bros. Lumber Co. MANUFACTURERS OF
Of Ontario, Limited
MILLS at SPRAGGE, Algoma Dist., Ont. on "Soo" Branch C.P.R.
OFFICES { Manning Arcade, Toronto
Coristine Building, Montreal
And at Mills at Spragge.
White and Red Pine Lumber and Lath
Water Shipments

THE M. BRENNEN & SONS MANUFACTURING CO., LIMITED

Saw Mills at RAINY LAKE, Ontario. Planing Mill and Head Office: HAMILTON, Ontario.

THE NIPISSING LUMBER COMPANY, LIMITED

Mills at CACHE BAY and SPANISH RIVER, Ontario.

Manufacturers of and Wholesale Dealers in all kinds of LUMBER AND LATH

Both Railway Delivery and Water Shipments. Correspondence Solicited. The NIPISSING LUMBER CO., Limited Head Office: HAMILTON, ONT.

AUGER & SON - Quebec
PULP WOOD AND TIES

Bought at Any Station.

Also Dimension Timber, Sawn to Sizes, Telegraph Poles and Lumber.—Write Us.

A. F. BURY AUSTIN
WHOLESALE LUMBER and TIMBER
CANADA PINE

Bank of Ottawa Building, 224 St. James St., MONTREAL, CANADA

SPECIALTIES: Railway ridge Timber and all kinds of Hardwoods; Ship Decking, Norway and White Pine, Dimension Timber, Norway Car Sills, Car Flooring, Telegraph Poles, Railway Ties, Oak and Whitewood, Planed and rough Lumber, British Columbia Pine, Southern Pine, &c.; Birch Flooring, hollow back, end butted.

Sole Eastern Agent for The North Pacific Lumber Company, Limited, Barnet, B. C.

Douglas Fir: Timber in any size or length up to 90 feet long. Timber Planers face up to 24 inch x 30 inch. Dry Kilns of large capacity. Rough and Dressed Lumber, Douglas Fir and Cedar.

WRITE FOR PARTICULARS AND QUOTATIONS.

R. LAIDLAW LUMBER CO.

18 Toronto Street, Toronto

JAS. PLAYFAIR. D. L. WHITE.
PLAYFAIR & WHITE
Manufacturers and Wholesale Dealers
LUMBER • LATH • SHINGLES

Contractors for Railway Supplies BILL TIMBER a Specialty MIDLAND, ONT

A. & P. WHITE Manufacturers of and Dealers in.....
Sawn and Planed Lumber, Dimension Timber. Joisting Car Sills, Car Flooring, Shingles and Lath.
PEMBROKE ONT.

F. MCGIBBON & SONS, PENETANGUISHENE ONT.
Manufacturers of Pine, Hemlock and Hardwood Lumber, and dealers in Cordwood Hemlock Bills cut on short notice.

MAITLAND, RIXON & CO. OWEN SOUND, ONTARIO.
Manufacturers and Dealers
LUMBER LATH, TIES, POLES, SHINGLES, ETC.
Make a Specialty of Long Pine, Cedar and Hemlock Bill Stuff. We ship by C. P. R., G. T. R., and by Water.

Turner Lumber Co., Limited MANUFACTURERS
LUMBER and LATH
Shipments by Rail or Water. Midland, Ont.

D. D. FLANNER H. W. REEVES
FLANNER & REEVES
Manufacturers and Wholesalers of
WHITE AND NORWAY PINE LUMBER
LATH AND SHINGLES
CAR AND CARGO MIDLAND, ONTARIO

HARDWOOD FLOORING
End Matched, Bored, Steel Polished, and Bundled
Send for Price List
A few cars of selected Maple and Birch and other Hardwoods at close price
THE SEAMAN KENT CO., Limited
60 Bay St., Toronto Factory, Meaford, Ont.

ROBT. STEWART LIMITED
GUELPH, ONTARIO
MANUFACTURERS OF
Doors, Sash, Mouldings,
Stairs, Hardwood Flooring, Etc.
Canadian and American Hard and Soft Woods of all descriptions
SPECIALTIES
YELLOW PINE AND OAK TIMBER
Sole Canadian Representative of the
SOUTHERN CYPRESS LUMBER SELLING COMPANY
New Orleans, La.

BRITISH COLUMBIA LETTER.

Correspondence of the CANADA LUMBERMAN.)

VANCOUVER, B. C., February 19th, 1905.—Conditions generally are improving, and mills are cutting with the prospect of a good trade this spring. One thing that will help restore the market in the Territories is the action of the Pacific Coast Manufacturer's Association, the members of which are in the neighboring states, in increasing the price to the extent of about 50 cents all along the line. No. 1 and No. 2 5-8 fir ceiling and No. 1 and No. 2 fir drop siding were increased \$1 a thousand, and all six inch fir ceiling was advanced \$1 a thousand higher than the four inch. Lath went up 25 cents. per M, and advances were made in 1 x 4 and 1 x 6 common boards and fencing, shiplap, fir joists and scantlings and timbers and cedar siding. These increases had been expected for some time, but will not affect the millmen on this side of the line. Naturally, if higher prices are charged for American lumber there should be more of a chance in the Northwest for the Canadian article.

Logs are still going up, and the top notch figure of \$9 is beginning to be quoted. With the opening of the spring trade the demand is increasing, and a large number of camps are being re-opened and new ones started up.

It is reported on pretty good authority

that the Chemainus mills have secured contracts for the supplying of 30,000,000 feet of lumber to points in the Territories during this season. Shipment is facilitated by the bringing of loaded cars from Vancouver island on barges.

General regret is felt among the lumbermen in the west because of the untimely death of Mr. W. R. Beatty as a result of injuries sustained in the fire which destroyed the boarding house of the Arrowhead Lumber Company on the 6th instant. The fire was caused by a dog upsetting a lamp. Mr. Beatty had only returned from the east the evening previous. R. Taggart, a saw filer in the employ of the company, was burned to death in the same fire.

Another fire took place on the 11th instant, when the dry kilns of the E. H. Heaps Company, at their No. 2 mill at Ruskin, were burned. The destruction was total, the loss being between \$8,000 and \$9,000, with insurance.

Several cargoes of lumber are being shipped to Japan, some having already gone from this port, while others are loading. The German ship Neck arrived in port last week from Eagle Harbor to take on lumber for Yokohama. She is the largest which has loaded here for some months.

Americans are steadily becoming more largely interested in timber in this pro-

vince. The deal which has been pending for some months has been consummated and capitalists from the state of Washington have acquired large limits on Vancouver island, the principal portion of which are E. & N. railway lands. The price paid was in the neighborhood of \$250,000. Another company is to take 26,000,000 feet of timber off a reserve on the Campbell river, and Dan McLeod left here a few days ago to start operations.

Large timber limits are owned in this province by Thomas Merrill, Aaron P. Bliss and Clark L. Ring, of Saginaw, Mich.; Thomas D. Merrill, of Duluth; and Richard D. Merrill, of Seattle, but no mills will be erected here until the Government gives assurance that further taxes will not be levied. These men are establishing a large industry in Washington, but it is stated export cannot be made from their limits in British Columbia.

THE BARBADOS MARKET.

Under date of February 11th, Messrs. S. P. Musson, Son & Company, report as follows:

"The schooner Kestrel, from Lunenburg, N.S., to ourselves, with a mixed cargo of white pine, is the only arrival we have to note, but she proceeded to Trinidad on the strength of a better offer for her cargo than we elicited here. The deck load of the Margaret M. Riley's car-

go, to which we alluded in our last, was placed by us at \$26.30 for merchantable and \$18.60 for second quality white pine, and \$22.10 for shipping and \$16.10 for second quality spruce, while our neighbors inform us that they obtained similar prices for her inboard cargo. Our market for white pine is rather heavily stocked, and while shipping spruce is in light stock and would probably bring late rates, second quality is not wanted, recent arrivals having principally consisted of this description. No arrivals of shingles to report, and stocks are being gradually reduced. Next arrivals of both Long Gaspé and Laying cedar should meet with a ready sale at remunerative prices."

SHIPPING MATTERS.

The following charters are reported: Steamer Pontiac, St. John, N.B., to w.c. England, two trips, deals, 35s.; a steamer of 1,800 standards, West Bay, N.S., to w.c. England or e.c. Ireland deals, 36s. 3d., half birch.

A number of lumber charters are reported from British Columbia. Current rates are as follows: To Sydney, 28s. 9d. to 30s.; Melbourne or Adelaide, 30s. to 32s. 6d.; Port Pirie, 30s. to 32s. 6d.; Fremantle, 37s. to 40s.; Shanghai, 33s. 9d. to 35s.; Taku, 35s. to 37s. 6d.; West Coast S.A., 33s. 9d. to 35s.; South Africa, 47s. 6d. to 50s.; U.K. or Continent, 50s. to 52s. 6d.

UNITED STATES MANUFACTURERS AND WHOLESALERS

YOU
CAN
REACH

THE BONSAK LUMBER CO.
WHOLESALE HARDWOODS

ST. LOUIS
BY
RAIL, MAIL
WIRE OR
'PHONE

H. D. WIGGIN BOSTON, MASS.
89 STATE ST.
will inspect at mill and PAY CASH for

LOG RUN
Elm, Ash, Bass and other Hardwood
CORRESPONDENCE SOLICITED.

YELLOW PINE

We are in position to give first class stock. Reasonable prices. Prompt shipments. Mills in Alabama Mississippi and Arkansas.

MANN, WATSON & CO. Muskegon, Mich.

ACME LUMBER CO.

Grand Rapids, Mich., U.S.A.

Wholesale Hardwoods
Hard Maple and Rock Elm our Specialty.
We invite correspondence whether you wish to buy or sell.

ONE DOLLAR

Will pay your subscription to the CANADA LUMBERMAN for

ONE YEAR

WANTED 5/8 Inch Quartered Canadian Spruce and Thick Birch

J. F. QUIGLEY LUMBER CO.

94 Pearl Street

Grand Rapids, Mich.

THE ROBERT H. JENKS LUMBER CO.
CLEVELAND, OHIO

MANUFACTURERS AND WHOLESALERS OF

YELLOW PINE, POPLAR, HEMLOCK AND HARDWOODS
Yellow Pine Timbers a Specialty

Indiana Lumber & Veneer Co.
INDIANAPOLIS, IND.

Sawed and Sliced Quartered Oak a Specialty

Correspondence Solicited. 

Veneers

FRANK C. BURY

BURY & NOBLE

MASON A. NOBLE

WHOLESALE

LUMBER - DETROIT

MICHIGAN

Send us your inquiries for Southern Yellow Pine.

CHARLOTTE HAEBERLE

Wholesale and Retail Dealer in

YELLOW PINE and OAK TIMBER

Large stock of Timbers and Bill Stuff carried in stock.
All sizes and lengths for immediate delivery.

Telephone No. 10 - - - Cedar Street, NIAGARA FALLS, N.Y.

McGLURE LUMBER CO.

Wholesale Dealers in . . .

Hardwood Lumber

Carry in Stock and Have for Sale

ASH, BASSWOOD, BEECH, BIRCH, BUTTERNUT, CHERRY, CHESTNUT, COTTONWOOD, CYPRESS, ELM, GUM, HICKORY, MAHOGANY, MAPLE, OAK, POPAR, SYCAMORE, WALNUT, POLES (Oak, Hickory and Ash), RIMS and SPOKES (Oak and Hickory), OAK BENDING PLANK, OAK BILL STUFF, RAILWAY TIES.

Office and Yards: 520 to 530 Franklin St., DETROIT, MICH.

Correspondence invited on All Hardwoods.

CANADIAN LUMBER SHIPMENTS.

From St. John, N.B.: Steamer Evangeline, for London, 29,274 ft. birch plank, 3,572 ft. birch ends. Steamer Corinthian, for Liverpool, 466,390 ft. deals, 7,240 ft. ends. Schooner Basutoland, for Barbadoes, 140,742 ft. pine boards, 104 310 ft. spruce boards. Schooner Gypsum King, for City Island, 294,446 ft. deals, 1,000,000 laths. Steamer Salacia, for Glasgow, 1,194 pcs. oak lumber, 1,508 walnut lumber, 20 maple logs, 13,785 ft. spruce deals, 24,750 ft. pine deals, 41 pcs. birch timber. Brigantine Atalanta, for Bermuda, 6,000

ft. spruce plank, 5,035 ft. deals, 10,043 ft. boards, 91,000 laths. Schooner Abbie C. Stubbs, for New Haven, 358,862 ft. deals. Steamer Bengore Head, for Dublin, 822,544 ft. deals, 500 ft. flooring, 641 bds. pulp boards. Steamer Briardene, for Bermuda, 15,800 onion crates, by A. Cushing & Co.; 15,250 onion crates, by G. & G. Flewwelling Mtg. Co.

From Portland, Maine: Steamer Ontarian, for Glasgow, 2,449 pcs. lumber, 3,778 pcs. deals, 20 pcs. timber, 8, 85 bds. shooks, by Grand Trunk Railway. Steamer Kildona, for London, 5 bds.

lumber, 2,912 pcs. lumber, 1 box blocks, 1,599 pcs. planks, by Grand Trunk Railway.

and in the northern interior of the Island. The deal has been pending for some months.

TIMBER LIMIT TRANSACTIONS.

A large area of timber lands on Vancouver Island, B.C., is reported to have recently been purchased by parties acting for the St. Paul Lumber Company, of Tacoma, Wash. The major portion of the lands in question was the property of the Esquimalt & Nainamo Railway Company—some situated on the west coast

Cable address: "Dundonian, Dundee."

BERG & SON,

Timber and Wood Pulp Agents and Brokers

DUNDEE, SCOTLAND

Contracts made between Shippers and Importers Correspondence solicited

BRITISH WOOD BROKERS AND IMPORTERS

FARNWORTH & JARDINE

Wood Brokers and Measurers

Cable Address "Farnworth," Liverpool. 2 Dale St., 71 Regent Road **BOOTLE LIVERPOOL, ENC.**

F. A. Lightbody & Co.

8 Gordon Street - GLASGOW, SCOTLAND

WOOD BROKERS

Cable Address: "TENEBRIS," GLASGOW. Codes: A. B. C., A 1, "Zebra" and Private. Agents for **CANADIAN WHITE PINE AND SPRUCE**; Hardwoods in Log, Etc. Shipments handled to the best advantage to all ports in the United Kingdom. Correspondence Solicited.

LOUIS BAMBERGER, 2 Broad Street Building, LONDON, E. C.

IMPORTER OF  Telegraphic Address "Bellywood, London."

Pine, Spruce and all Canadian Wood Goods

Are Open to Contract for Glued-Up **BASSWOOD KEYBOARDS**

ZEBRA CODE A. B. C. CODE DIRECTORY CODE

GELLIBRAND, HEYWOOD & CO.

Wood Agents and Brokers

Cable Address: "GELLICHT," LONDON 57 Gracechurch St. London, E.C. England

SMITH & TYRER - 14 Tithebarn Street, LIVERPOOL

.. WOOD AGENTS ..

Cable Address—"Walmer," Liverpool.

Halifax, N.S., Office—SMITH, TYRER & Co., Metropole Bldg., Hollis St. Halifax, N.S.

Edmiston & Mitchells

TIMBER BROKERS

Cable Address: "EDMISTON" Glasgow. 33 Renfield Street, GLASGOW

GANT & KEMP  **TIMBER BROKERS**

52 St. Enoch Square, GLASGOW

Cable Address: "TECTONA" Glasgow. At and A B C Codes used.

Every lumberman wants it **35 cents buys it**

Scribner's Lumber and Log Book

BRIMFUL OF EVERY-DAY PRACTICAL INFORMATION Address: THE CANADA LUMBERMAN, Toronto

CABLES, DOORCHEEK, LONDON

We are Buyers of Pine Doors and Mouldings, Electric Wire Casings, W.C. Seats, Wooden Mantel Pieces, Sashes and Frames, and all kinds of ready made joinery.

LONDON STORES: Locke's Wharf, Edmonton, N.

STAVERS & STAVERS

OFFICES: 158, Leadenhall Street, London, E.C.

Manufacturers and Importers of JOINERY

FELBER, JUCKER & CO.

Lumber Importers

MANCHESTER ENGLAND
Invite offers from Lumbermen for . . .
Spruce Deals and Battens, Spruce and Pine Floorings, Shooks, Sashes, Mouldings, Dowels Broom Handles, Chair Stock, Seats, etc., or any Woods Suitable for English Market.
Telegraphic Address: FELBER, MANCHESTER.

ASHTON & PETFORD

BISHOP LANE, - HULL, ENGLAND

BUYERS OF BOX SHOOKS

Invite correspondence from manufacturers who are in a position to export to Great Britain.
Cable address, "Shooks," Hull.
Codes—A. B. C. 4th Edition and Zebra.

JOSEPH OWEN & SONS, LTD.

Timber Importers

Cable Address "Owen Liverpool" Liverpool, Eng.

BUYERS OF

White Ash Logs and Planks.
Oak Logs and Planks.
Rock Maple Logs and Planks.
Rock Elm Logs.
Hickory Logs.

. . . ALSO . . .
All classes of Lumber and Manufactured Wood Goods suitable for the English Market.

JAMES WEBSTER & BROTHER

BOOTLE, LIVERPOOL, ENGLAND

TIMBER MERCHANTS

BUYERS OF Oak, Birch, Ash, Grey Elm Logs and Lumber, Elm Staves and Heading, Handles of all description
Specialty

ALFRED DOBELL & COMPANY

WOOD AGENTS AND BROKERS

Liverpool and London Chambers - LIVERPOOL, ENGLAND

CABLE ADDRESS "DOBELL LIVERPOOL"

THOMPSON, BLOIS & KJELLGREN

ALL KINDS OF LUMBER AND LOGS

CASH ADVANCES MADE AGAINST SHIPPING DOCUMENTS . . .

BRANCH OFFICES
41 Corporation St., MANCHESTER
Waterloo Chambers, GLASGOW

HEAD OFFICE
17 Gracechurch St., LONDON, E.C.

BRANCH OFFICE
Brook 1, HAMBURG

THE ONTARIO LUMBER CO. LIMITED

Mills: North Bay, C.P.R. and G.T.R. Delivery.

MANUFACTURERS WHITE PINE LUMBER, LATH AND SHINGLES.

35 and 36 Home Life Building TORONTO, Ont. MILLS: French River, Georgian Bay Water Shipment Only.

WILLIAMSON & MORRISON LUMBER

Mills at L'Original, Ont.

HEAD OFFICE: 30 St. John Street, MONTREAL, P.Q.

WHOLESALE

JAS. LUNNY & CO.,

HINTONBURG, ONT.

Have for Sale {ASH, ELM, BASSWOOD, PINE, SPRUCE AND HEMLOCK IN QUANTITIES

Eastern Agents--B. C. Shingles and Douglas Fir, all dimensions Can dress to 24x30. B. C. Cedar Write for quotations

ONE DOLLAR

Will pay your Subscription to the Weekly and Monthly CANADA LUMBERMAN for

ONE YEAR

GEO. G. GLADMAN MANUFACTURER OF WHITE PINE AND HEMLOCK LUMBER LATH AND SHINGLES Mills at Smith's Bay Township of Carling PARRY SOUND, ONT. CORRESPONDENCE SOLICITED

THE WOODSTOCK LUMBER & MANUFACTURING CO., Wo dstock, Ontario. Manufacturers of and Wholesale Dealers in Pine, Hemlock & Hardwood Lumber ENQUIRIES PROMPTLY ATTENDED TO.

A. P. EBERT

MANUFACTURER OF AND DEALER IN

Pine and Hardwood Lumber, Lath, Shingles, Posts, Broom Handles, and Short Hardwood Dimension Stock WARTON, ONT.

THE NEW LINE

Through the Spruce Forests of the Laurentian Mountains--between Quebec and Hawkesbury.

WATER-POWERS, TIMBER LIMITS AND ELECTRIC POWER FOR SALE. IDEAL PULP-MILL SITES.

Unexcelled Export Facilities at Quebec.

A. J. GORRIE, General Supt. MONTREAL GUY TOMBS G. P. & P. A.



CURRENT LUMBER PRICES--WHOLESALE

TORONTO, ONT.

CAR OR CARGO LOTS.

Table listing lumber prices for various types like 1 inch No. 1 Pine, 1 1/2 inch No. 1 Pine, etc., with prices per 1000 ft.

HARDWOODS--PER M FEET CAR LOTS.

Quality, 15 and 25 unless otherwise specified.

Table listing hardwood prices for species like Elm, Birch, Cherry, Elm, Maple, Oak, Walnut, etc.

QUEBEC, QUE.

WHITE PINE--IN THE RAFT

Table listing white pine prices in raft for square white pine, first class Ottawa waney, etc.

RED PINE--IN THE RAFT.

Table listing red pine prices in raft for measured off, shipping order, etc.

OAK--MICHIGAN AND OHIO.

Table listing oak prices by the dram, according to average and quality.

ELM.

Table listing elm prices by the dram, according to average and quality.

ASH.

Table listing ash prices for 10 inches and up, according to average and quality.

BIRCH.

Table listing birch prices for 40 inch, 16 inch, 17 inch, 18 inch.

OTTAWA, ONT.

MANUFACTURERS' PRICES.

Table listing manufacturers' prices for pine, good sidings, 1 in. x 8 in. and up, etc.

Table listing lumber prices for Pine good strips, Pine shorts, Pine good shorts, etc.

BAY CITY AND SAGINAW, MICH.

UPPER AND SELECTS.

Table listing lumber prices for Uppers, 1 in., 10 in. and up, etc.

FINE COMMON.

Table listing lumber prices for 1 in., 8 in. and up wide, etc.

B FINE COMMON OR NO 1 CUTTING.

Table listing lumber prices for 1 in., 7 in. and up wide, etc.

STRIPS, A AND B (CLEAR AND SELECTS).

Table listing lumber prices for 1 1/2 in., 4, 5 and 7 in. wide, etc.

FINE COMMON OR C

Table listing lumber prices for 1 in., 4, 5 in. wide, etc.

SELECTED NO. 1 SHELVING OR FENCING STRIPS.

Table listing lumber prices for 1 1/2 in., 4, 5, 6 in. wide, etc.

BARN BOARDS OR STOCKS.

Table listing lumber prices for No. 1, 12 in., 8 and 7 in., etc.

SHIPPING CULLS OR BOX.

Table listing lumber prices for 1 in., 4 and 5 in. wide, etc.

SHAKY CLEAR.

Table listing lumber prices for 1 in., 3, 4, 5, 7, 8 and gin. v. ide, etc.

SHINGLES, 18-IN.

Table listing lumber prices for Pine, XXXX, Clear Bntts., etc.

LATH.

Table listing lumber prices for No. 1 White Pine, No. 2 White Pine, Hemlock, etc.

ALBANY, N.Y.

PINE.

Table listing lumber prices for Uppers, 3 in., 2 1/2 in., etc., and other lumber types.

Table listing lumber prices for LATH, SHINGLES, Sawed Pine, Clear bntts., etc.

BUFFALO AND TONAWANDA, N.Y.

WHITE PINE.

(Wholesale selling price.)

Table listing lumber prices for Uppers, 1, 1 1/2, 1 3/4 and 2 in., etc.

The following quotations on hardwoods represent the jobber's buying price at Buffalo and Tonawanda:

WHITE ASH.

Table listing lumber prices for 1st & 2nd, 1 inch, 1 1/2 to 2 in., etc.

BLACK AND BROWN ASH.

Table listing lumber prices for 1st & 2nd, 6 inch np, etc.

BIRCH.

Table listing lumber prices for 1st & 2nd, 6 inch & np, red, etc.

ELM.

Table listing lumber prices for 1st & 2d, rock, 6 in & np, etc.

MAPLE.

Table listing lumber prices for 1st & 2nd hard, etc.

BOSTON, MASS.

Table listing lumber prices for White Pine Uppers, Selects, etc.

NEW BRUNSWICK CEDAR SHINGLES.

Table listing lumber prices for Extras, Clears, Second clears, etc.

BRITISH COLUMBIA SHINGLES.

Table listing lumber prices for Red Cedar Extras, etc.



GREAT CONCATENATION AT TORONTO.

Friday, February 10th, 1905, will long be remembered by the large number of Hoo-Hoo members who were fortunate enough to attend the concatenation in Toronto. To say that the affair was a splendid success conveys but a meagre impression of the exuberant enjoyment which was afforded the hundred and more wearers of the black cat button. The Toronto Hoo-Hoo had been active for many days, and had made arrangements at McConkey's for the reception of a large class of purblind kittens, in which they were not disappointed. Trains from all directions brought their delegations, and withal there was a merry time.

Arcanoper W. C. Laidlaw, of the Supreme Nine, who has now become an adept in the art of holding concatenations, extended a guiding hand, although the efficient work of Vicegerent Snark D. Ferguson, of London, showed him to be complete master of the situation. The officers were:

Snark, D. Ferguson, London.
Senior Hoo-Hoo, J. H. Lavalley, Orillia.
Junior Hoo-Hoo, J. G. Cane, Toronto.
Bojum, A. K. McIntosh, Toronto.
Scrivenoter, W. J. Hetherington, Toronto.
Jabberwock, C. H. Belton, London.
Custocation, W. J. McBeth, Toronto.
Arcanoper, Fred Shirley, Galt.
Gurdon, Oscar Vogt, Galt.

The officers were assisted by Arthur Dinnis and A. E. Eckardt, of Toronto, and Alex. Leishman, of Orillia. Twenty-four candidates were led blind-folded into the gardens, where Junior Hoo-Hoo Cane held sway and allotted to each the travels which he should take o'er thorny paths and 'midst mysterious tribulations. All the devices of torture were in operation, but all survived, and finally the kittens bowed their heads three times three in submission. The more robust, at the solicitation of the Snark, were seated on the King's throne, where they delivered "brief" addresses eulogistic of the Hoo-Hoo initiation. The following kittens answered the roll call:

Allan "Anthracite" Leadley; Benj. Franklin Keane; Wm. Alfred Dunn; Benj. Hoge-man Stewart; Thos. Seymour Young; Melville "Collins" Bertram; Geo. Henry Precious; Adam Ely Kleippert; Chas. Leonard Bailey; Albert Edward Cates; Allan "Quarry" McPherson; Geo. Everett Clipsham; Marshall Henry Brown; Thos. Hulbert Miller; Geo. Clark Goodfellow; Thos. Edward Milburn; David Sheur Pratt; Dwight Joseph Turner; Chas. William Pitt; Michael Joseph Rock; Joseph Albert McDonald; William Brown Boyd; Walter Scott Waldie; Thos. Edward Manley Chew.

It was twelve o'clock before the banquet was reached, but it was a magnificent treat. The menu was quite unique, being printed on a quarter-inch board of three-ply veneer fur-

nished by the Imperial Veneer Company, of Sundridge, Ont.

MENU

NOSED BLUE POINTS.

"My mouth hath itched all this long day"—*Chaucer*

SLIPPERY ELM WITH CONSOMME JULIENNE.

"And slip no advantage that may secure you"—*B. Johnson*

FILLET OF TAN BARK AU VIN BLANC.

"As welcome as an unexpected order"—*Sam Higgins*

SWEETBREATHS IN SAWDUST.

"What new delusion charms your cheated eyes again"—*Dryden*

ROAST YOUNG TURKEY—CAR RENTAL RELISH.

"Take the bitter with the sweet"—*W. J. McBeth*

BAND AND GANG SAWED—SALADS.

"This comes well and excellent"—*Shakespeare*

COMMON AND BETTER ICE-CREAM.

"Love betters what is best"—*Wordsworth*

RANDOM WIDTHS AND LENGTHS IN CAKES.

"Many a shaft at random sent
Finds mark the archer little meant"

SWEET WILLOW BON BONS—SALTED ALMONDS.

"We have some salt of our youth in us"—*Shakespeare*

HOT LIQUID FROM THE ROASTED BERRY OF THE G. ARABICA.

MATURE BROWN OCTOBER

NAPANEE BITTERS

LOGGING BEE LIQUID

"The early village cock
Hath twice done salutation to the morn"—*Shakespeare*

"But we are held with melodious harmony
In willing chains and sweet captivity"—*Milton*

During the feast musical numbers were rendered by Messrs. Ruthven McDonald and Bert Harvey, Mr. F. Weaver officiating as accompanist. The banquet came to an end about 1.30 a.m., and it was unanimously voted that



MR. D. FERGUSON,
Vicegerent Snark for Eastern Canada.

the concatenation had been an unqualified success and a credit to those who had worked so faithfully to that end.

As a souvenir of the occasion Messrs. E. C. Atkins & Company, saw manufacturers, of Indianapolis, through their Toronto representative, Mr. C. D. Ten Eyck, presented each person present with a pair of cuff links bearing their well-known "A.A.A." trade mark.

LUMBERMEN REQUEST EQUALIZATION OF DUTY.

A deputation of British Columbia and Ontario lumbermen waited upon Sir Wilfrid Laurier, Hon. Wm. Paterson and Senator Templeman at Ottawa on February 7th and asked for the imposition of a duty on lumber equal to that levied by the United States. The Ontario lumbermen included: J. B. Miller, Toronto; W. D. Lummis, Sarnia; W. B. Tindall, Toronto; Jas. Playfair, Midland; W. P. Bull, Toronto; D. L. White, Midland; R. Cook, South River; W. J. Sheppard, Waubaushene; Wm. Lovering, Waubaushene; Dwight J. Turner, Midland; J. R. Booth, A. McCormick, D. Murphy, C. McCool and Jas. W. Woods, Ottawa; A. B. Gordon, Sudbury;

E. J. Harrison, Owen Sound; J. P. Newman, Wiarton; J. E. Keenan, Owen Sound; Geo. Thomson, Goderich; R. H. Roys, Sandwich; W. B. Maclean, Toronto; J. C. Shook, Peterborough; Wm. Scott, Port Arthur; D. C. Cameron, Rat Portage; C. Beck, Penetanguishene; George Gordon, Sturgeon Falls, and R. J. Younge, Secretary Canadian Manufacturers' Association.

Among the British Columbia men were: T. F. Paterson, Vancouver; J. Hendry, Vancouver; R. P. McLennan, Vancouver; E. H. Heaps, Vancouver; W. Stone, Vancouver; Hon. W. C. Wells, Victoria; R. E. Beattie and A. Leitch, Cranbrook; F. W. Jones, Golden, and T. H. Moffat, Lethbridge.

Mr. F. F. Patterson asked that a duty be imposed on lumber and shingles similar to that imposed by the United States, and submitted a list of mills in British Columbia which had been shut down on account of the unfair conditions which exist. He argued that the people of the Territories are able to pay the duty. They are, he said, better off than those of British Columbia. He maintained that lumber was the one thing unprotected among the things needed by the western farmer. In concluding, Mr. Paterson remarked on the success in Vancouver of the dumping clause so far as machinery went. He would like to see the dumping clause enforced against lumber from the United States. Finally, he declared that in British Columbia and Northern Ontario there were mills enough to supply Manitoba and the Territories, and that there was no need for an increase in prices.

Mr. F. W. Jones, representing the mills in the Mountain district of British Columbia, declared that there was no danger of a monopoly, and that the price of lumber would not be increased. The lumbermen were willing to enter into an agreement to that effect with the Government provided they were given the desired protection.

Mr. D. C. Cameron, of the Rat Portage Lumber Company, said that his company had invested \$150,000 in mills and timber limits in British Columbia, but that they could not be profitably operated under present conditions.

Other speakers were J. Hendry, R. P. McLennan and W. Stone, of Vancouver, R. E. Beattie, of Cranbrook, B.C., W. P. Bull, of Toronto, C. Beck, of Penetanguishene, and F. Ballantyne, the latter representing the Canadian Manufacturers' Association.

The Premier replied briefly, stating that he had been impressed by their presentation of the facts, particularly by their exposition of the manner in which the lumberman was taxed while enjoying no protection. When the duty had been taken off, lumber went into the United States free of duty, but that condition had ceased. During the campaign he had promised an early revision of the tariff, but in the absence of the Finance Minister the matter was in abeyance. In conclusion, he exhorted them to have faith in the Government.

A deputation will this week interview Hon. W. S. Fielding, Minister of Trade Finance, who has just returned from a European trip.

THE NEWS

ONTARIO.

—John Morwood is establishing a saw mill at Alvinston, Ont.

—William Rankin has started a saw mill at Dover Centre, Ont.

—The Seaman-Kent Company, of Meaford, Ont., are building a new saw mill at Dyer's Bay.

—Lockhart & Company have made some improvements to their saw mill plant at Cash Point, Ont.

—The Imperial Veneer Company have resumed operations at Sundridge, Ont., under the management of F. A. Mulholland.

—C. T. Groh, of Hespeler, Ont., has acquired a half interest in the saw mill and lumber business of James Eagle at Preston, Ont.

—The Gilmour Door Company, Limited, of Trenton, Ont., have been authorized to increase their capital stock to the sum of \$300,000.

—Jacob Hess has purchased an interest in a saw mill near Sundridge, Ont., which will be operated under the firm name of Beatty & Hess.

—The Bracebridge Furniture Company, Limited, has been incorporated to acquire the business of the Hess Furniture Company at Bracebridge, Ont. J. D. Shier is one of the promoters.

—The Rathbun Company have sold their lumber business at Lindsay, Ont., to Baker & Bryans, Limited. The transfer is said to include mills, warehouse, towing outfit and timber limits.

—It is reported that the Red Cliff Lumber Company have decided to build a large saw mill at Rainy River, Ont., with the object of catering to the lumber requirements of the Canadian Northwest.

—The New York Central Railway recently acquired the Ottawa and New York Railway and intend rebuilding the line. It is understood to be the intention to make a strong bid for the carrying of lumber.

—Mr. J. M. Prentiss, of the Toronto office of Pitts & Charlton, is the proud possessor of a very fine pair of moose horns, measuring 54 inches from tip to tip. They came from the logging camp of the firm at Whitefish, Ont.

—Baker & Bryans, Limited, has been incorporated at Lindsay, Ont., to manufacture lumber, shingles, sash, doors, etc., the capital stock being \$100,000. The provisional directors are G. H. N. Baker, Robert Bryans and G. H. Hopkins.

—The lumber firm of Loveland & Stone, whose mills are at Cutler, Ont., have built an Anglican church at that place which will seat about eighty persons and have furnished the lumber to build a large Roman Catholic church. The generosity of this firm is greatly appreciated by the residents in the neighborhood.

—The North Bruce Lumber Company, Limited, have commenced business in Toronto, their charter giving

them power to manufacture and deal in lumber and timber. The provisional directors are Frederick Reilly, John B. Bartram, H. M. Merton, William Pinkerton, and A. D. Chisholm.

—An Ontario charter has been granted to the Northern Land & Lumber Company, Limited, of Port Arthur, Ont., to acquire the business heretofore carried on by the Northern Land & Lumber Company and to build mills for the manufacture of lumber, shingles, etc. The directors are Herbert Shear, G. F. Clarkson, W. E. Pollard, W. F. Langworthy and A. J. McComber.

—W. H. Gill and O. E. Fortune have purchased the lumber interests of Gilmour & Company, Limited, at Trenton, Ont., and will carry on a wholesale and retail business under the firm name of Gill & Fortune. They have purchased all the lumber stock of Gilmour & Company now in their yards at Trenton, as well as the lumber, etc., which they had along the line of the C. O. railway, including existing log contracts. Both members of the new firm have been connected with Gilmour & Company for the past twenty-five years.

—Grier & Ford, whose mill near Bracebridge, Ont., was burned last fall, have built and equipped a new mill and have it already in operation. All the old equipment was discarded and an entirely new outfit installed, and the mill is working very satisfactorily. It has a capacity of 25,000 feet per day. The firm have in stock about 4,000,000 feet of logs, comprising pine, hemlock, basswood, birch and maple, which they will manufacture into lumber before the 1st of September next. They also operate under contract a mill at Pusey, Ont.

—The business which has been carried on so successfully by Ross & Taylor, of Exeter, Ont., during the past twenty-eight years, has been converted into a joint stock company and is now known as the Ross-Taylor Company, Limited. The capital stock is \$30,000, and the officers of the company are: President, J. W. Taylor; secretary-treasurer, D. A. Ross; directors, J. W. Taylor, D. A. Ross and J. R. Hind. The general manager is J. W. Taylor. In addition to their former business, consisting of lumber yards, planing mills and the manufacture of sash, doors, and all kinds of building materials made of wood, they have built a new saw mill and are getting in a large stock of logs, consisting of maple, basswood, rock and soft elm, etc. The new firm start out under favourable conditions, having a large business established and bright prospects of increasing it. We wish them continued success.

THE EASTERN PROVINCES.

—James McGowan is rebuilding his cooperage factory at Cornwallis, N. S.

—Francois Girard, saw mill, St. Nazaire, Que., has been succeeded by Girard & Paul.

—D. L. Nobles & Company, lumber dealers, St. John, N. B., have discontinued business.

—Andrew Hignault was killed in J. R. Booth's lumber yard at Fort Coulonge by logs rolling over him.

—The United Lumber Company, Limited, have registered their business in Montreal.

—Flavien Bergeren and Gedeon Laliberte have registered as proprietors of a saw mill business at St. Flavien, Que.

—Three men were slightly injured by the explosion of a boiler in James Kennedy's portable saw mill at Narepis Station, N.B.

—Dorais & Sabourin, sash and door factory, St. Laurent, Que., have dissolved, and have been succeeded by Dorais & Fils.

—The death took place last month of Neree Poisson, lumber manufacturer, Gently, Que., and the business will be continued by his son, J. B. Poisson.

—The woodworking factory of Paul Lea at Moncton, N.B., will likely go into the hands of a joint stock company, but Mr. Lea is expected to continue as manager.

—F. E. Sayre & Company, Limited, of St. John, N.B., has been incorporated, to carry on a general lumbering business, the capitalization being \$60,000. The promoters include Frederick E. Sayer, John E. Sayer and J. W. Holly, lumber merchants, of St. John.

—A company, composed of A. J. Gregory, K.C., and other local capitalists, is being formed to establish a new woodworking factory at Gibson, N.B. An option has been secured on T. E. Rabbitt & Sons' saw mill, which it is proposed to convert into a woodworking factory.

—A meeting of the shareholders of the Dalhousie Lumber Company was held at St. John, N. B., last month, when the following officers and directors were elected: President, James Manchester; vice-president, George McKean; Joseph T. Knight, Henry Hilyard and W. T. Whitehead.

—The Sussex Lumber Company, Limited, of Sussex, N. B., has been incorporated, with a capital of \$25,000, to carry on a general lumber business. The promoters include James A. McArthur and James A. Campbell, of Sussex; James Smith, of Millstream; and Charles Craig and Michael Purtle, of Elkmouth, B.C.

—The Restigouche Woodworking Company, Limited, of Dalhousie, N. B., is seeking incorporation, to carry on business as indicated by the name. The nominal capital is \$50,000. Among the applicants are W. S. Montgomery and David Richards, lumber merchants, and James Evans, mill man, all of Dalhousie.

—Stevens & Lawson, solicitors, Edmundston, N. B., are asking for the incorporation of the Winding Ledges Power & Boom Company, to sort, raft and drive all logs coming down the St. John river, with power to construct dams across the said river at the Winding Ledges, in the parish of St. Francis, N. B.

—The Anderson Furniture Company have commenced operations in their new factory at Newcastle, N. B. The plant consists of a saw mill and dimension mill 40x120 feet, a machinery building 64x120 feet, a storage and shipping room 40x120 feet, all four stories, a dry kiln 40x00 feet, and a boiler and engine house. O. G. Anderson, the promoter of this company, was

CRAIG MINE CRYSTAL CORUNDUM WHEELS

Our Pure Crystal Corundum Saw Gummars have no equal for their Rapid, Cool, Cutting Properties.

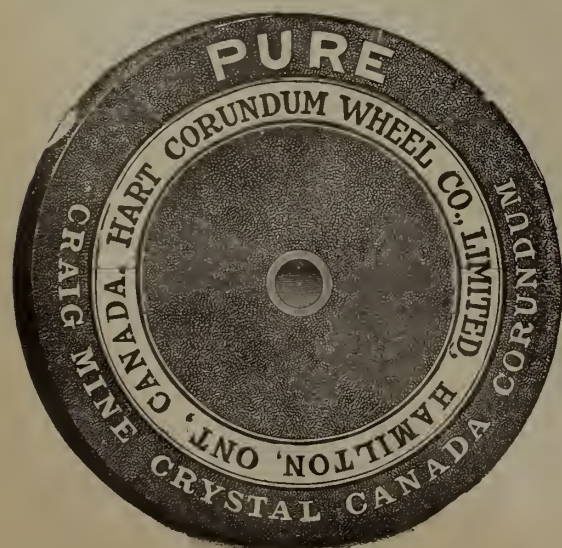

Read the following from Bulletin 180 of the United States Geological Survey, which says:

"Often a distinction is made between emery and corundum, many persons not recognizing emery as a variety of corundum.

Emery is a mechanical admixture of corundum and magnetite or hematite. It is, of course, the presence of corundum in the emery that gives to it its abrasive qualities and makes it of commercial value, and the abrasive efficiency of emeries varies according to the percentage of corundum they contain."

Emery is imported, mined by Greeks and Turks and contains only about 25% corundum. Our Crystal Corundum is guaranteed to be 98% pure alumina, a Canadian product, mined and manufactured by Canadians for Canadians.

HART CORUNDUM WHEEL COMPANY, Limited, Hamilton, Ont, Can.

formerly at the head of a large furniture company at Woodstock, Ont.

—P. Clinch, secretary of the New Brunswick Board of Underwriters, recently read a paper on the "Saw Mill Hazard" before the Insurance Institute of Montreal. He remarked that the modern saw mill was in every way a better risk than that of twenty-five years ago, although too little attention was still paid to whitewashing.

—At the annual meeting of the Alexander Gibson Manufacturing Company, held at Marysville, N.B., recently, the following officers were elected: President—Alexander Gibson, sr.; vice-president, Alexander Gibson, jr.; treasurer, Hugh H. McLean; directors, Alexander Gibson, sr., Alexander Gibson, jr., David McLaren, S. L. Richey and Hugh H. McLean.

—The New Brunswick Government have granted incorporation to Timothy Lynch & Company, Limited, of Nelson, N. B., to carry on a general lumber and saw mill business. The capital stock is placed at \$200,000, and the promoters include Timothy Lynch, T. L. Lynch and T. B. Lynch, of Fredericton, and James D. McMillan, of Boiestown. Mr. McMillan is a surveyor of lumber.

MANITOBA AND THE TERRITORIES.

—J. H. Lyons has established a lumber yard at Humboldt, N. W. T.

—The Stony Creek Lumber Company, Sparling, N.W.T., has been incorporated.

—John Kerr is opening a lumber yard at Souris, Man., which makes three yards at that point.

—R. J. Noble, lumber dealer, Oxbow, N.W.T., has sold out to the Robertson-Adams Lumber Company.

—A new lumber yard has been opened at Duck Lake, N. W. T., by Telford Bros., of Prince Albert.

—Cushing Bros. have purchased the lumber business of the Red Deer Lumber Company at Edmonton, N. W. T.

—Hunter & DeFehr, lumber dealers, Carstairs, N. W. T., have been succeeded by the Carstairs Lumber Company.

—The Moose Mountain Lumber & Hardware Company are moving their head office from Arcola, N. W. T., to Winnipeg, Man.

—The safe of the Sprague Lumber Company in the office on Higgins ave., Winnipeg, was recently broken into by thieves, who secured cash to the amount of \$243.40.

—The Largon Lumber Company have opened a yard at Baltimore, a new town on the Canadian Northern Railway about 35 miles north of Saskatoon, N. W. T.

—The Anglin Lumber & Pulp Company, recently organized, with headquarters at Winnipeg and a capital of \$300,000, propose to build saw and pulp mills on the Winnipeg river near Lac du Bonnet. Thomas Sharpe, Thomas Wade and Edward Hagar, of Winnipeg, are interested in the company.

—The Great Northern Lumber Company, Limited, recently incorporated, will engage in the lumber business in Western Canada on a large scale. H. J. Haskamp, of St. Cloud, Minn., who has large interests in North Dakota, is president of the company, which is capitalized at \$100,000. It is proposed to establish lumber yards on the main line of the Canadian Northern Railway in Manitoba.

—A new concern recently incorporated at Winnipeg, Man., is the Empire Sash & Door Company, Limited, which has a capital of \$100,000. The charter permits the company to manufacture and deal in lumber, sash, doors and other building materials and to acquire timber limits, coal lands, quarries, mines, etc. The promoters are W. H. McWilliams, George R. Crowe and John Love, grain merchants, of Winnipeg, and G. F. Piper, of Minneapolis.

—We understand that McDiarmid & Clark expect to have their new planing mill at Brandon, Man., in operation early in March. They do not intend manufacturing stock sashes and doors for the present, but will confine themselves to mouldings, casings, base, frames and special size windows, doors and turned work. They have installed an electric motor and purchase their power from the Brandon Electric Power Company. Mr. McDiarmid has been engaged in the lumber trade at Brandon for the past four years, while Mr. Clark has been foreman and superintendent of the Hanbury Manufacturing Company's factory at that place for the past fifteen years.

BRITISH COLUMBIA.

—Richardson & Company have succeeded Greenhow & Richardson, saw millers, Peachland, B. C.

—The mills of the Yale-Columbia Lumber Company at Nakusp, West Rohson, and Cascade, B. C., are to be enlarged and improved.

—James Leigh & Sons, of Victoria, B. C., have purchased a large planer and matcher from Cowan & Company, of Galt, Ont.

—C. H. Vogel, C.E., of Ottawa, recently visited British Columbia for the purpose of investigating the pulp prospects of that province.

—S. F. McKay is installing a saw mill upon the limits owned by the Active Gold Mining Company on Porcupine Creek, near Ymir, B. C.

—George W. Campbell, late manager of the Rat Portage Lumber Company at Vancouver, B. C., is building a saw mill up the coast.

—The Dominion Government have made a grant of \$50,000 towards a Dominion Exhibition to be held at New Westminster, B. C., this year.

—It is reported that the Barclay Sound Cedar Company have purchased the mill and timber limits owned by J. Bird, of Alhemi, B. C., and that the mill will be enlarged.

—The citizens of New Westminster, B. C., are anxiously waiting the re-opening of the Ross-McLaren saw mill on the Fraser river near that city. The mill was

recently purchased by American capitalists and it is expected to resume operations this spring.

—The Golden River Lumber Company, of Golden, B.C., have applied for a provincial charter to enable them to operate electric light and waterworks plants in Golden and vicinity.

—The Small & Bucklin Company have about completed arrangements with the city of New Westminster, B.C., for the requisite site on which to build a saw mill, shingle mill and box factory.

—The large new mill of the Elk Lumber & Manufacturing Company at Fernie, B. C., will be completed at an early date. The building proper and hurner are finished and the machinery is now being installed.

—The Cascade Mills Company, Limited, which acquired the property of the Cascade Lumber Company, of Vancouver, B.C., have commenced operations and expect to be able to carry on a successful business.

—A. Cotton, shingle manufacturer, Vancouver, B.C., has built a dry kiln 30 x 80 feet and has installed in his mill some new machines manufactured by the Schaaque Machine Works, of New Westminster.

—The Vancouver Lumber Company intend considerably increasing their saw mill plant at Vancouver, B.C., at an estimated cost of \$150,000. This mill is located on the site of the old Leamy & Kyle plant, which was installed in 1886 and was operated by them until 1890, when George Cassidy took it over and operated it for three years. From 1894 to 1903 the mill lay idle, but in the latter year it was acquired by J. D. Moody, J. E. Tucker and A. L. Clark, who compose the Vancouver Lumber Company. The site comprises about 10 acres of land and is one of the best on False Creek.

PUBLICATIONS.

A catalogue of Westcott's patent lathe chucks and Little Giant drill chucks has been received from the Westcott Chuck Company, of Oneida, N. Y.

Messrs. Joshua Oldham & Sons, saw manufacturers, Brooklyn, N. Y., are sending out a small booklet containing many testimonials to the superior quality of their saws.

The Robert H. Jenks Lumber Company, Cleveland, Ohio, have favored their customers and friends with a very useful lumber reckoner. They express the hope that it will lighten the labors and increase the prosperity of the recipient as long as it shall last.

CALIFORNIA EXCURSION.

The Chicago, Union Pacific and North Western line runs through first class pullman and tourist sleeping cars to points in California and Oregon. Personally conducted excursions from Chicago every week. Lowest rates, choice of routes. Finest scenery. Special attention given to family parties. For maps, illustrated folders and rates, address B. H. Bennett, general agent, 2 King street, Toronto, Ont.

The Hanchett Adjustable Saw Swage

For large and small Circulars, Bands, Band Resaw, and Gang Saws.

FILERS MILLMEN

A TRIAL WILL COST YOU NOTHING. We send you these tools for you to use for 30 days, free. If you then feel that you can afford to do without them you are to return them at our expense. They save Time—Files—Labor—Saws. Adjustments are perfect. Construction simple. Workmanship the best. They have stood the test. You run no risk when you purchase a Hanchett Saw Swage. They are standard make.



Hanchett Circular Saw Swage with Bench Attachment

Write for circular to—

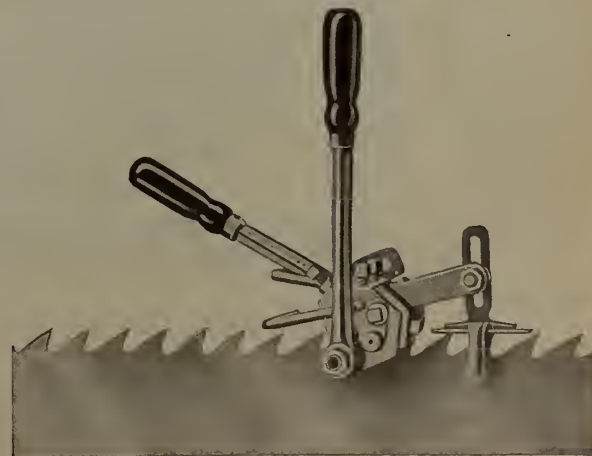

Hanchett Band Saw Swage

HANCHETT SWAGE WORKS,

Big Rapids,

Mich., U. S. A.

WE MAKE SWAGE SHAPERS.

FOR THE CAMP

We have a very suitable lot of goods for camp supplies. We make this kind of trade a specialty. You who are not getting suited just as well as you would like, try us for your next order, and give us a chance to demonstrate our ability to give you satisfaction in this very important department of your business.

H. P. ECKARDT & CO.

Wholesale Grocers

TORONTO

TRADE NOTES.

D. K. McLaren, manufacturer of leather belting, Montreal, has opened a branch at 169 Prince William street, St. John, N.B.

The Georgian Bay Engineering Works are putting on the market a new babbitt metal, which will be known as the "Midland" bearing metal.

A new company has been organized at Sarnia, Ont., to be known as the Conner-Woods Machinery Company, Limited, the intention being to manufacture saw mill and agricultural machinery.

The Huntsville Foundry & Machine Company, Limited, Huntsville, Ont., has been incorporated, to carry on a foundry and general machinery business, the capital being \$20,000. J. H. Johnson, D. M. Grant and Frank H. Tool are directors.

The Dymont Foundry Company, of Barrie, Ont., are utilizing compressed air in their foundry, chiefly for driving the machinery employed in the construction of boilers and for sifting sand in the moulding shop. They have a large number of orders on hand and are running their foundry to its full capacity.

The Dominion Camp Equipment Company, Limited, of Montreal, has recently been incorporated, with a capital of \$20,000, to manufacture and deal in camp and other ranges, camp hardware, waterproof clothing, etc., and to acquire the patent rights now the property of D. W. Lockerby.

In the description of the Hanchett band swage shaper in our February number, the name of the Gordon Hollow Blast Grate Company erroneously appeared under the cut as manufacturers. The manufacturers of this popular swage shaper are the Hanchett Swage Works, of Big Rapids, Mich.

Peter Bertram, manager of the Dundas Axe Works, Dundas, Ont., advises us that their "Lumberman's" axe is meeting with a large sale. This axe is made with a heavy portion of a very fine quality of axe steel. It is tempered in oil by a new process that insures an even hardness and toughness until the axe is worn out. In severe weather the frost should be drawn from the axe before commencing to chop.

The Manitoba Iron Works, Limited, of Winnipeg, have under construction at the present time in their boiler shop, the largest tubular boiler that has ever been seen west of Lake Superior. It is seven feet in diameter, 18 feet long, shell 9-16ths of an inch thick, with heads 5-8ths of an inch, double butt strap joints, with eight rows of rivets and 106-4 inch tubes. The boiler is guaranteed for a working pressure of 140 lbs., and will be installed in the new sash and door factory of the Rat Portage Lumber Company.

The directors of the Lumber Insurance Company of New York held their annual meeting Wednesday, February 8, in the offices of McKelvey & Mattocks, at 66 Broadway. The following were present: S. M. Clement, Buffalo; Lewis Dill, Baltimore; William H. Gratwick, Buffalo; W. C. Laidlaw, Toronto, Ont.; John Jay McKelvey, New York; George A. Mitchell, Buffalo; E. F. Perry, New York; Henry J. Pierce, Buffalo; C. H. Prescott, jr., Cleveland; Frank C. Rice, Springfield, Mass.; Horace F. Taylor, Buffalo, and Pendennis White, Buffalo. Frederick W. Mat-

tocks, of the firm of McKelvey & Mattocks, was elected to a vacancy on the board.

The annual meeting of the board of the Lumber Underwriters was held in the offices of McKelvey & Mattocks, 66 Broadway, Thursday, February 9. The following were present: Frederick W. Cole, New York; Lewis Dill, Baltimore; W. C. Laidlaw, Toronto, Ont.; H. Shumway Lee, Buffalo; Robert C. Lippincott, Philadelphia; John Jay McKelvey, New York; Frederick W. Mattocks, New York; Eugene F. Perry, New York; C. H. Prescott, jr., Cleveland; Frank C. Rice, Springfield, Mass.; Horace F. Taylor, Buffalo; M. S. Tremaine, Buffalo, and Pendennis White, Buffalo.

We understand that the Syracuse Smelting Works, of Montreal, are receiving some very large orders for their "Manganese" anti-friction metal. The new U. S. battleship "Nebraska," which was lately launched at Seattle, Wash., has its bearings lined with this metal, and has been pronounced satisfactory by the United States Government inspectors. "Manganese" anti-friction metal has not been on the market very long, but it is having a large sale. It is specially adapted for saw mills and woodworking machinery, and several of the largest mills in Canada and the United States use it exclusively. The company are sending on application miniature bars of this metal, which can be used as a paper-weight.

ATKINS ALWAYS AHEAD.

We have had hundreds of examples of the rapid rise of individuals from comparative poverty to wealth through sheer force of character and application and in each instance an analysis of the process of transition reveals the fact that the result was accomplished along some one line of thought or endeavor.

No more remarkable evidence of the successful development of an "idea" can be presented than the growth that has attended the great saw manufacturing establishment of E. C. Atkins & Company, of Indianapolis, Indiana. "Superiority in quality" was the "idea" which predominated in the production of the Atkins brand of saws from the casting of the steel ingot to the finished article, and to no other one reason can be attributed the wonderful demand for Atkins saws which comes from all parts of the world.

The Atkins brand of saws may be rightly entitled to its inception away back in the 17th century when the Atkins ancestors were making saws in old England and have continued there and in this country in an unbroken line down to the present time.

The success of this institution was primarily due to the mechanical genius of its founder, Mr. E. C. Atkins, who established the business in 1857, alone and without capital, though endowed with abundant energy and perseverance. His knowledge and experience in saw making was obtained in the saw factory of his father, then operating at Bristol, Connecticut. But the continued and unprecedented prosperity which has attended the business of the past few years is accounted for by the fact that not only the present head of the firm, Mr. H. C. Atkins, but every department superintendent, is an expert in his particular line, and "quality" is their watchword.

Less than twenty years ago the factory employed about one hundred and fifty men, and opened its first branch house at Memphis, Tenn. A short time afterward another branch was started in Chattanooga, which later was removed to Atlanta. Then in rapid succession branches were established at Minneapolis, Minn., Portland, Ore., New York City, Chicago, Ills., Toronto, Ont., Seattle, Wash., and last, but not least, San Francisco falls into line. The branch at San Francisco was opened the first of January and was necessitated because of the firm's increased business on the Coast which could not be accommodated to advantage from Portland and Seattle.

To take care of their rapidly increasing trade, the firm is constantly expanding their manufacturing facilities and several new buildings have lately been equipped and put into operation. About twelve hundred men are now employed at the factories and seventy salesmen are kept constantly on the road disposing of the enormous product of saws and tools whose trade mark, "Atkins Always Ahead," aptly describes their position in the minds of appreciative users.

The crown forests of Russia comprise 30,000,000 acres belonging to the Czar and 303,000,000 farmed by the national exchequer. The Czar employs 27,000 wood police, who cut 12,000,000 tons a year, chiefly for firewood. Twenty years ago wood-cutters in the United States felled timber covering 10,000 acres daily, but this wholesale destruction brought about such serious evils that of late measures have been taken, both by public authorities and private persons, for preserving existing trees and woods and for extensive planting where the ground is bare of timber.



Corrugated Iron
For Sidings, Roofings,
Ceilings, Etc.

Absolutely free from defects—made from very finest sheets.
Each sheet is accurately squared, and the corrugations pressed one at a time—not rolled—giving an exact fit without waste.
Any desired size or gauge—galvanized or painted—straight or curved.
Send us your specifications.

The Metallic Roofing Co.
WHOLESALE MANAGERS, LIMITED
TORONTO, CANADA.

SOMETHING
NEW
IN
LEATHER BELTING

“**AMPHIBIA**”

**GUARANTEED
ABSOLUTELY WATERPROOF
FOR**

**SAW & PULP MILLS
& ALL WET PLACES**

*WRITE FOR
DESCRIPTION & PRICES*

SADLER & HAWORTH

**TANNERS & MFRS.,
MONTREAL — TORONTO.**

FORESTRY DEPARTMENT

CANADIAN FORESTRY ASSOCIATION MEETING.

The sixth annual meeting of the Canadian Forestry Association will be held in the City Hall, Quebec, on Thursday and Friday, March 9th and 10th, 1905. The Board of Directors and the Local Committee have arranged a very interesting programme, and a large attendance and successful meeting is anticipated. A banquet will be held on Friday evening and it is probable that a trip on the ice-breaker Montcalm will be among the arrangements. The railway companies have agreed, as in previous years, to allow members and their wives, when accompanying them, return passage free, regardless of the number of attendants, provided a certificate is obtained from the railway ticket agent at the point where the ticket for Quebec is purchased.

The following papers have been arranged for: "The Forests of New Brunswick," by T.G. Loggie, Fredericton, N. B.; "The Forest Resources of Quebec," by J. C. Langelier, Department of Crown Lands, Quebec; "Forest Insects," by Rev. T. W. Fyles, Levis, Que.; "Forest Fires in British Columbia," by R. W. Brock, Queen's University, Kingston. A summary of reports on the fires in British Columbia during 1904, received by Mr. J. R. Anderson, Deputy Minister of Agriculture, will be presented. Mr. Jas. Leamy, Dominion Timber Agent at New Westminster, will also report on

the work of the fire preventive service on Dominion lands in British Columbia. An address on "Northern Quebec and Labrador" will be given by Commander A. P. Low, of the Geological Survey, and Dr. Judson F. Clark, Forester for the Ontario Bureau of Forestry, will deliver an illustrated address.

FOREST RESERVES CONTROLLED BY THE BUREAU OF FORESTRY.

On February 1st the formal transfer of the government forest reserves of the United States from the General Land Office to the Bureau of Forestry was made, in accordance with a law recently passed by congress and signed by the President. This transfer is the most important event in the history of the Forestry Bureau since its creation. It has been annually urged in messages to Congress by President Roosevelt, and before him by President McKinley. It brings the control of fifty-three government forest reserves, containing over 62,000,000 acres, or more than 96,000 square miles, where that control properly rests. It makes possible the more intelligent, because more scientific, conduct of these reserves, and centralizes the forestry work of the government. The anomalous situation of one government bureau devoting itself to the study of forestry, while an entirely separate bureau controlled the government forest possessions, is at last logically ended.

The dissolution is announced of Colwell & Cooper, lumber and agricultural implements, Nanton, N.W.T.

When completely established the Minnesota National Forest Reserve will contain about 225,000 acres. Of this area 105,000 acres have already been selected by the Government. Under the terms of the Morris law 95 per cent. of the pine timber thereon must be cut. This pine has been sold and the work of cutting was actively prosecuted last year. Nine logging camps were established, and the cutting began early in August. Two camps, which worked under a system of summer railroad logging, shut down for the season in November. The other seven camps, in which winter logging is being done, are still running.

The initial number of the Canadian Forestry Journal, the official organ of the Canadian Forestry Association, has made its appearance and is a very creditable production. The first article is a history of the Association by the editor, R. H. Campbell. Then follow articles entitled "Canada as a Field for Intelligent Forestry," by E. Stewart, Dominion Superintendent of Forestry; "Forest Influences," by Prof. J. B. Reynolds; "A Glance at Forest Conditions in New Brunswick," by G. U. Hay, D.Sc., St. John; "The Forest Resources of the Labrador Peninsula," by A. H. D. Ross, M.A., Yale Forest School, and an appropriate reference to the late John Bertram, of Toronto, who was a valued member of the Canadian Forestry Association. Several illustrations of forest scenes brighten the number.

The death is announced of P. Schwartz, of J. & P. Schwartz, lumber dealers, Altona, Man.

Allis-Chalmers-Bullock, Limited, Montreal

SAW MILL MACHINERY

Band and Circular Saw Mills, Carriages, Set Works and Appurtenances, Conveying and Transferring Machinery, Trimmers, Slashers and Cutting Off Saws, Edgers, Lath Mills and Bolters, Adjustable Arbor Boxes, Filing Room Tools, Timber Preserving Plants.

ALSO MAKERS IN CANADA OF . . . **BULLOCK ELECTRICAL MOTORS AND GENERATORS**

Head Office and Works : MONTREAL

Branches : HALIFAX, N. S. TORONTO, ONT. WINNIPEG, MAN. ROSSLAND and VANCOUVER, B. C.

TEARS, BITTER TEARS.

(With due apologies to Alfred, Lord Tennyson.)

Tears, bitter tears! I know well what they mean
Tears from the depths of an acute despair
Rise from the heart and gather to the eyes
When looking on the smoking ember heap
And thinking of the mill that is no more.

Too far, too much, I trusted to myself;
Put too much faith in never ending watch.
The angry flame has wiped quite out my wealth
And told the dreary story once again—
A twenty thousand loss, insurance nil.

Ah! hard to learn is wisdom at that price,
A price that means my whole life's labor lost.
But wisdom now is mine, insurance pays,
And Chance should not be trusted when relief
Can be obtained at sixty-six Broadway.

66 BROADWAY, NEW YORK,

is the home of the

Lumber Insurance Company of New York

and the

Lumber Underwriters

which with the

Toledo Fire and Marine Insurance Company

of Sandusky, Ohio

form the First Triumvirate of Lumber Insurance.

PERSONAL.

Mr. J. G. Jardine, Canadian trade commissioner for South Africa, has resigned his position owing to ill-health and returned to Toronto.

Hon. Francis J. Sweeney, M.P.P. for Westmoreland County, has been appointed Surveyor-General for the province of New Brunswick, as successor to Hon. A. T. Dunn.

Mr. Edgar Green, who has spent the past four years in South Carolina in the interests of G. W. Green & Sons, timber merchants, has returned to his home in Kingsville, Ont.

We regret to learn that Mr. James G. Spence, who for the past few months has been connected with the Manchester office of the Imperial Lumber Company, of Toronto, has been compelled, owing to ill health, to return to Canada.

Mr. William B. Comstock, a prominent lumberman and banker of Alpena, Mich., died in Detroit on February 7th, at the age of sixty-two years. He was associated with his brother, A. W. Comstock, in the lumber business and carried on operations in Michigan, Mississippi and Ontario.

Mr. M. Armstrong, of Armstrong Bros., lumber and veneer manufacturers, Markdale, Ont., was a visitor to Toronto early in February and gave the CANADA LUMBERMAN a call. He states that they had a success-

ful year in 1904 and are steadily increasing their trade in cheese box veneer, of which they make a specialty, shipping to all parts of Canada. They operate two saw mills and two veneer factories.

Mr. M. T. O'Connell has been appointed general manager of the Pigeon River Lumber Company, of Port Arthur, Ont. Mr. O'Connell is vice-president of the Wisconsin-Oregon Lumber Company and comes from Duluth. Mr. G. S. Clark, formerly of the Red Deer Lumber Company, has assumed full charge of the manufacturing department for the Pigeon River Company.

The news of the death of Mr. W. R. Beatty, manager of the Arrowhead Lumber Company, Arrowhead, B.C., was received with profound regret by his numerous acquaintances. Mr. Beatty lost his life as a result of a fire which destroyed the company's boarding house at Arrowhead. He led the volunteers who turned out to subdue the flames and through the energetic efforts of himself and his men confined the loss practically to the boarding house. It is said that on two previous occasions he nearly lost his life trying to save persons from being burned to death. Mr. Beatty was widely known in lumbering circles through his varied interests, being engaged alternately in Ontario, Nova Scotia and British Columbia. He represented Parry Sound for two terms in the Ontario Legislature. He was perhaps the most popular man in the Parry Sound district and

no man had a larger place in the affections of the people.

Messrs. J. O. Gilbert & Son, Bishop's Crossing, Que., write: "We are much pleased with the January number (monthly) of THE LUMBERMAN, and would like an extra copy."

It is said that the Pennsylvania Railroad Company has under consideration the project of planting, besides the 300,000 already planted on its right of way, 1,000,000 trees annually for a series of years from which to draw future supplies of cross-ties. It is also declared that these trees will be yellow locust, a rapid growing species peculiarly adapted to the use noted.

**THE MONTHLY JOURNAL
Concrete**

Devoted to cement manufacture and the various forms of concrete construction.
\$1.00 a year; single copy 15c.
CONCRETE PUBLISHING Co., - Detroit, Mich.

G. T. KNIGHT & SON

**Manufacturers of
Building Supplies**

we make a specialty of
Doors and Sashes; Mouldings and all
kinds of turned goods.

Address, MEAFORD, ONT.

FOR THE CAMP TABLE

- Mess Pork
- Smoked Hams
- Short Cut Pork
- Roll Bacon
- Plate Beef
- Pure Lard
- Dressed Fresh Beef
- Pork Sausage
- Long Clear Bacon, Butter, Cheese, &c.

Write us for Special Prices on Car Load Lots.

THE PARK BLACKWELL CO., L'T'D

PORK AND BEEF PACKERS
TORONTO

Normandin Cement Block Machine



There's
Money
in the
Block Business

Experience not
Necessary for
Success.

The
NORMANDIN
machine
does the work.

THINK IT OVER, and decide quickly to start a Block Yard in your town. Others are making a success of the business—You can too. Write to-day for particulars of the NORMANDIN MACHINE. Hundreds of them in use daily. Hand labor and a little common sense will turn out a perfect stone on the NORMANDIN. This is the machine that took the Highest Award at St. Louis Fair, 1904. The United States Government Engineers will buy nothing but the best. They bought and are using the NORMANDIN—IT MUST be right.

The NORMANDIN complete equipment comprises over 200 parts and weighs 3,000 lbs.

SOLE AGENTS FOR CANADA

The Cement Block Building Co., Limited
Winnipeg - - - Vancouver - - - Toronto
Largest Cement Block Manufacturers in Canada



Seal Polar Lumber King Spartan Hussar

GENUINE DUCK BRANDS - NONE BETTER - SATISFACTION GUARANTEED

MANUFACTURED BY

THE MERCHANTS RUBBER COMPANY., Limited
BERLIN, CANADA



Caesar Regina Trojan Lanceit Norwich

Please mention THE CANADA LUMBERMAN when corresponding with advertisers

**1,000 Mershon
Band Resaws**

IN DAILY USE



BUY DIRECT AND GET

— THE —

GENUINE

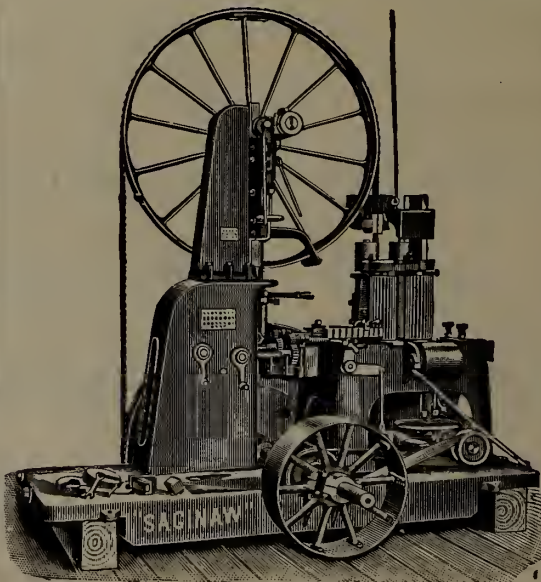

W.B. MERSON & CO.

Saginaw

Mich., - U. S. A.

"MIDLAND" BABBITT METAL.

One of the latest scientific discoveries along the lines of a metal used for machinery bearings, has proven that a triple or quadruple alloy composed of certain percentages of pure virgin metals, properly mixed, and fluxed with a certain chloride, will produce astonishing results. One of the finest babbitt metals lately placed upon the market is the "Midland," manufactured by the Georgian Bay Engineering Works, of Midland, Ont. This metal seems to contain all the desirable features that users of bearing metal could wish for. To enumerate some of its good points, for instance, it contains a certain amount of graphite or plumbago which makes it a self-lubricating babbitt. It possesses the quality of expanding on cooling, thus filling up the box into which it is poured, and making a neat, clean,

clear, sharp casting. Another point, "Midland" metal stands up under the heaviest as well as the lightest kind of work, and is especially compounded for high speed machinery, such as is used in planing mills, or heavy machinery of saw mills, in fact there is hardly a place that this metal cannot be used for the purpose for which it is designed. Further particulars will be cheerfully given by the makers, who guarantee every pound of metal turned out by them to perform the work for which it is wanted, and to contain nothing but the very purest of virgin metals obtainable.

Woods, Limited, of Ottawa, manufacturers of lumbermen's supplies, have just awarded the contract for the erection of another new building on Slater street, adjoining their present factory and warehouse.

—Gillies Bros., Limited, of Braeside, Ont., have asked for an enlargement of their charter to permit them to carry on lumbering and pulp manufacturing and to deal in marble, cement, brick, etc., also to construct docks, flumes, bridges and similar works and to develop electric and other power.

THE TIME TO QUIT WORK

The proper time to quit work is when **Clark's Pork and Beans** is served. Clark's is so good it gives a good excuse to start again. Only select Canadian pork and prime Canadian beans in the kind made by

WILLIAM CLARK, Montreal.

P. PAYETTE & CO.

Manufacturers of Saw Mill and Engine Machinery and all kinds of Marine Machinery.
PENETANGHISHENE, ONT.

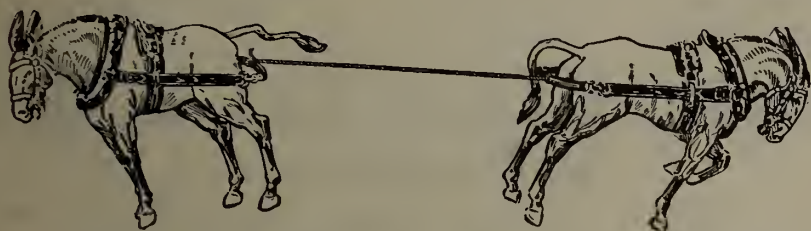

These Mules Cannot Break This Yarn

BECAUSE IT WAS MADE BY THE

Consumers Cordage Co., Limited



Poor Yarn is Dear at Any Price

We Manufacture

**Double and Single Lath Yarn,
Shingle Yarn, and Cordage**

Of Every Description

Our mills are equipped with the latest improved machinery for making extra long lengths of Transmission Rope.

CONSUMERS CORDAGE CO., LIMITED

Montreal and Halifax

SPROCKET

CHAIN

We have in transit from the factory the largest Carload Shipment of Sprocket Chain ever brought into Winnipeg, and we are prepared to quote better discounts than have ever been given the Saw-mill Trade before.

We are after the chain trade and propose to get it by carrying the stock and quoting the prices.

Our stock is at Winnipeg and at your disposal.

The Manitoba Iron Works, Lt'd.
901-909 Logan Ave., Winnipeg

Manufacturers of and Dealers in Saw-mill Machinery and Supplies.

THE LUMBER MUTUAL FIRE INSURANCE COMPANY
BOSTON, MASS.

STRENGTH

NET ASSETS, DECEMBER 31, 1904

\$583,407.29

ECONOMY

DIVIDENDS TO POLICY HOLDERS

33 $\frac{1}{3}$ %

MAIL EXPIRING POLICIES WITH YOUR ORDER.

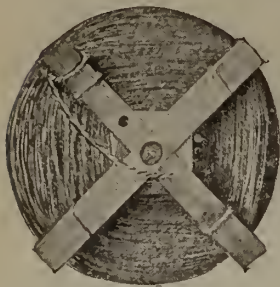

PURE MANILA ROPE

Highest Quality Made

BRITISH MANILA

SISAL ROPE

Pure Sisal

LATH YARN



WIRE, WRITE OR PHONE

Canadian Cordage & Manufacturing Company, Limited
Peterboro, Ontario, Canada

Long Distance Phone 162

Our Rope and Lath Yarn are Recognized as the Best on the Market.

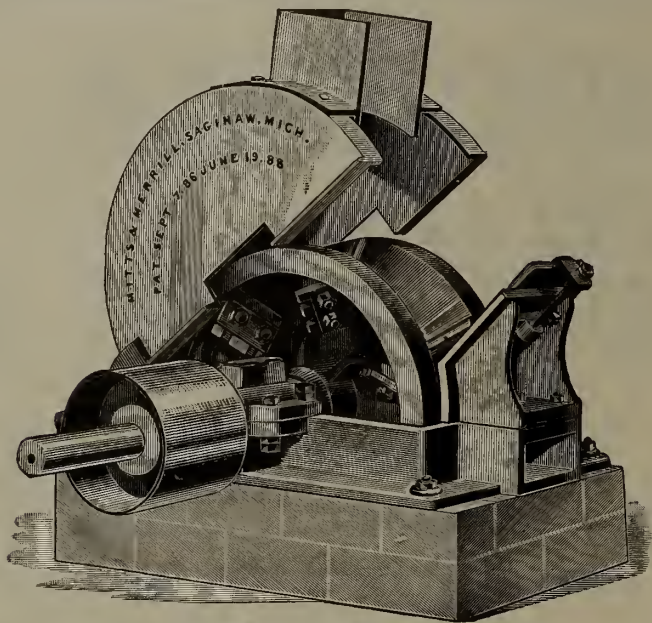

We Make **“HOG”** For Cutting

Slabs, Edgings and Blocks, Shingle, Sawdust and Splints, Planing Mill and Box Factory Refuse, Heading and Veneer Mill Waste, into fuel chips. Extract Chips into fine chips. Millions of dollars saved by their use. Try One.

MITTS & MERRILL

807 Tilden Street, - - Saginaw, Mich.

SEND FOR CIRCULAR E

Cowan & Co. of Galt, Limited

GALT, CANADA

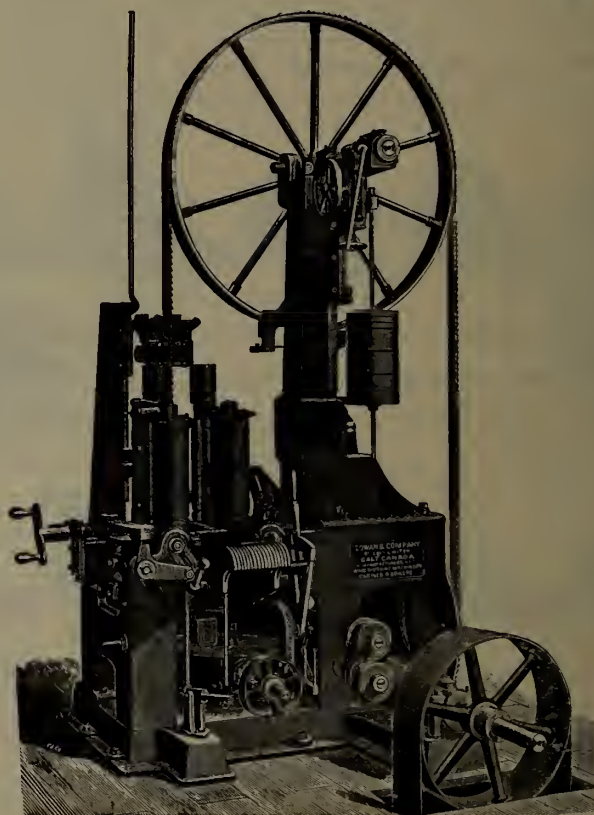

No. O Band Resaw, M167

We build this machine in different styles and sizes, with wheels 42", 48", 54" and 60" diameter. Also a full line of the most up-to-date Wood Working Machinery of superior material and workmanship.

Write for cuts and prices.

WHEN FIXING UP YOUR MILL

For next spring's business we would like to hear from you regarding the Belting you will doubtless require. In the manufacture of



FAIRBANKS'  BRAND LEATHER BELTING

we think we have attained a higher degree of excellence than was heretofore obtainable. We use nothing but the best Packer's Butts and then only the toughest part of these. The belly and the working parts of the animal we do not use at all, and every belt from six inches up has the backbone strip of the animal in it. We carry a complete stock and can make prompt shipment. Write to us about it.

The Fairbanks Co.

Montreal

Toronto

Vancouver

Winnipeg

ATKINS ALWAYS AHEAD!



Substance, not the Shadow of Quality

Characterizes the Silver Steel Saws bearing the celebrated "AAA" trade mark. Superiority of material, our patent process of tempering, perfection of grinding and experience and skill in workmanship are the leading features in the make-up of an Atkins Saw. These qualities insure perfect running saws and satisfaction to the user. The highest intrinsic value ever offered and the most efficient service possible to obtain are secured when you purchase an Atkins Saw. A trial is convincing proof. Think it over and let's have your order now.

Our Machine Knives, too, are made with a view of retaining you as a permanent, satisfied patron. What more can we say?

Mill Supplies of every description. Write for our 1905 Saw and Saw Tool Catalogue and Sawyer's Hand Book. It's free.

E. C. ATKINS & CO., Inc.,

Leading Manufacturers of Circular, Band, Cross-Cut, Hand and Wood Saws, Etc.

Factories and Home Office,
Indianapolis, Ind.

Canadian Branch,
56 King St. East, Toronto, Ont.

QUALITY IS THE THING!

THE E. L. PURVIS CO.,
18 COLBORNE ST. TORONTO, ONT.

Fire Clay Products

THE GLENYARDS FIRE CLAY CO.

BONNYBRIDGE, SCOTLAND.

Cablegrams: Glenyards, Bonnybridge.

Codes used, A.B.C. and Glenyards.

PIPE AND BOILER COVERINGS

Asbestos Mineral Wool
and all kinds of Fireproofing

Material Agents for

FAMOUS MICA COVERINGS

Manufacturers of all kinds of **Fire Clay Goods, Ganister and Silica Goods**, for **Iron and Steel Works and Gas Works, including Boiler Seating Blocks and Covers of all sizes.** Ground Fire Clay, Ganister and Silica in all kinds of Packages

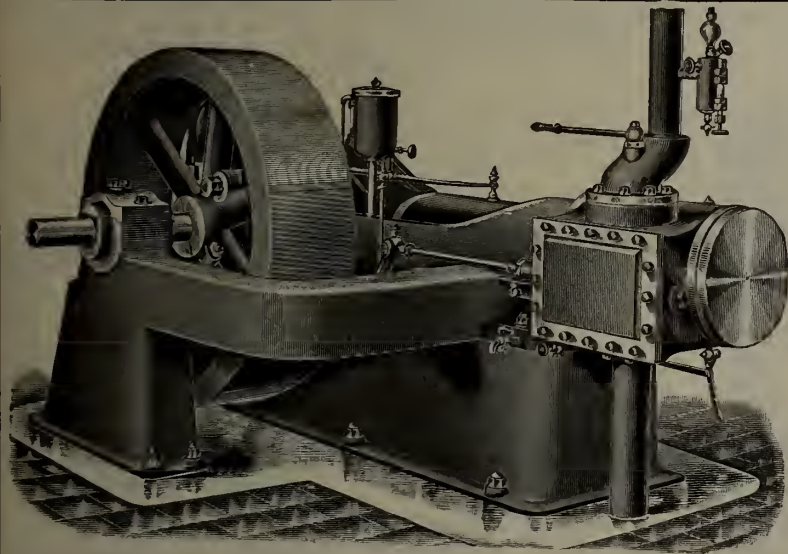

GIVES NO TROUBLE

A mill owner writes us: "The 16x16 Robb-Armstrong Automatic Engine installed in our saw mill in 1903 has proved very satisfactory. It has been running steadily five months each sawing season of 1903 and 1904 and has given us no trouble whatever. We drive with it a large rotary, lath mill, patent haul-up, complete sawdust conveyor throughout the mill, live rolls, trimmers, slab saws and planers. We do not have to develop its full power to do this work. The governor is very sensitive, there being only a variation of 3 per cent. when saw is running in and out of cut. We use steam feed to drive our rotary and put through the mill 750 to 800 logs per day."

ROBB ENGINEERING CO., Limited, Amherst, N.S.

Agents: { William McKay, 320 Ossington Avenue, Toronto.
Watson Jack & Company, Bell Telephone Building, Montreal.
J. F. Porter, 355 Carlton Street, Winnipeg.

IN OUR LINE WE LEAD

McFarlane Patent Wrot Forged Steel Socket Cant Dogs

Leads them All



Used in every Lumbering District from the Atlantic to the Pacific Ocean

Extra Fine Quality Split Rock
Maple Handles

Round and Duck Bill Peaveys and
Cant Hooks

Write for quotations. If once used you will never return to the old malleable sockets.

THE MCFARLANE-NEILL MANUFACTURING CO., Limited ST. MARY'S, YORK COUNTY
New Brunswick



Ewart's Is The Standard Detachable Chain Belting

Only the Best Material Used

Our Chains Can Be Relied on



GIANT CHAIN

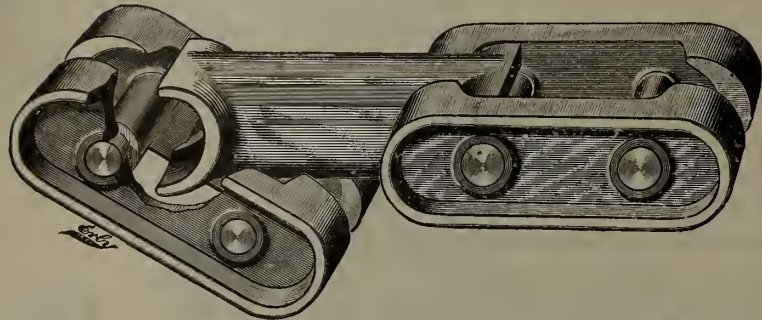

The Giant is a Strong Detachable Chain. As a Log Haul Chain it has been well appreciated by both lumber and pulp manufacturers.



NO. 86 HEAVY LOG CHAIN

FORGED SAWDUST CHAIN

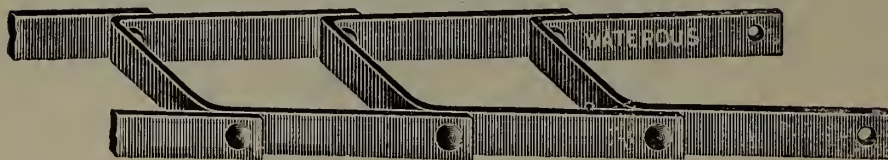

R SINGLE

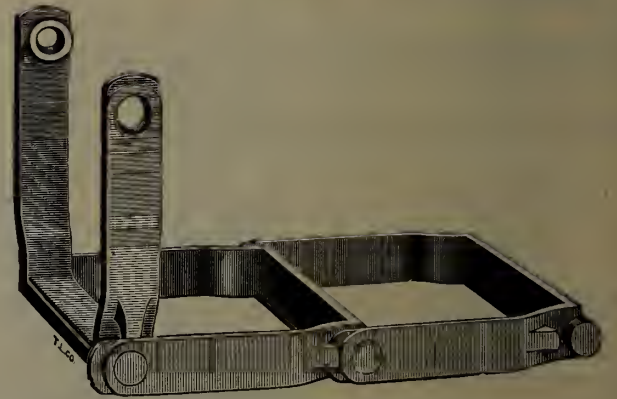

DETACHABLE SAWDUST CHAIN 550



DOUBLE R



MALLEABLE RIVETED SAWDUST CHAIN

These Chains may be used all Plain Links, all attachments or any portion of Plain and Attachment Links mixed.



SPECIAL TRANSFER CHAIN 500

A few of the many lines of Chain we Make and Handle.

We can Supply any style of Chain required for Saw Mill work, also for Elevators and Conveyors, with necessary Sprockets and Gearing for same.

:-:-:-:

Manufacturers of a full line of

**SAW MILL MACHINERY,
ENGINES, BOILERS, ETC.**

:-:-:-:

Ask for Prices and Catalogs

WATEROUS, Brantford, Canada

Circular

Saw Swage

Can be used on Band Saws simply by using the Band Saw Front Gauge.



We make nothing but Saw Swages and use the finest material obtainable in manufacturing.

Let me send you reference of some who have used them.

D. J. CROWELL,

200 The Terrace,
BUFFALO, N. Y.

DO YOU LACK STEAM?

WE CAN HELP YOU.

Are your boilers making all the steam they should?
What do you do with your sawdust and other refuse?
Are you ever obliged to shut down to wait for steam to rise?

The **Gordon Hollow Blast Grate** develops every ounce of power a boiler is capable of generating, and gives as good results with wet, green or frozen sawdust or other refuse as a draft grate gives with dry wood. As a gate is provided to regulate the air supply, the necessary steam pressure can be maintained *regardless of the weather.*

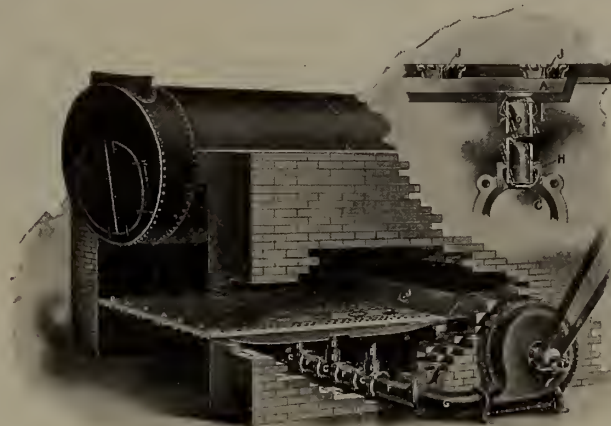

This celebrated grate, the *original* hollow blast grate, which has now been on the market for *sixteen* years, during which time it has been improved from time to time and kept thoroughly up-to-date by *practical* and progressive men, is sold *on approval*, thirty days being given in which to thoroughly test it, it being returnable *at our expense* if unsatisfactory.

In writing for prices, give number of boilers, width of furnaces or ovens and length of grates.

The Gordon Hollow Blast Grate Co., Greenville, Mich.

Established 1889

The largest manufacturer of Blast Grates, Edgers and Trimmers in the World.
SEND FOR CATALOGUE D.



The "Alligator" Steam Warping Tugs

SIDE WHEELS OR TWIN SCREWS

The Twin Screws are arranged with flexible joint to raise up in crossing portage

MANUFACTURED BY

WEST & PEACHEY, - Simcoe, Ont.

Cables carried in stock for renewals

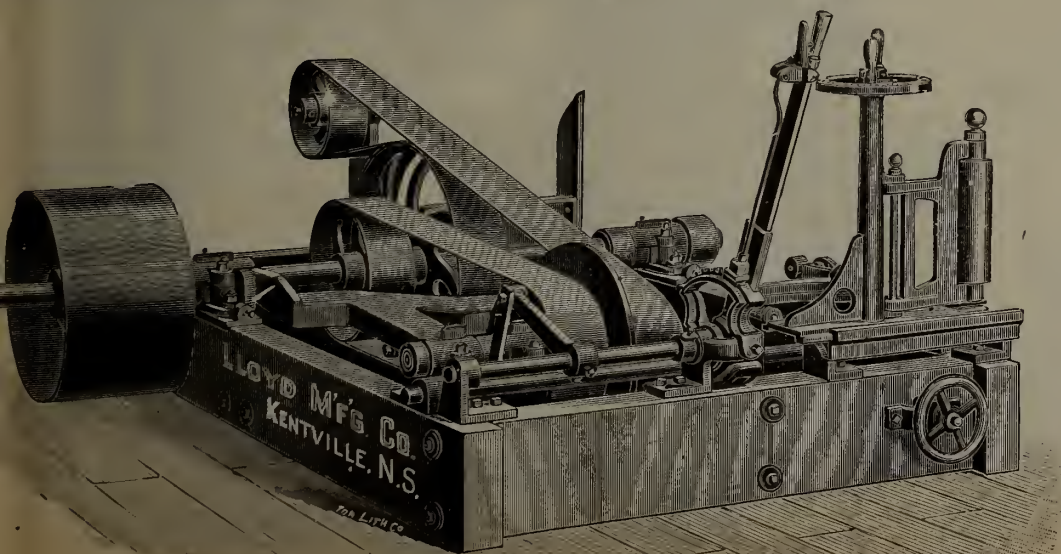

Lloyd Manufacturing Go'y

JOHN I. LLOYD, Proprietor.

SAW MILL OUTFITS

Pulp Machinery, Belting, Etc.

OUR SPECIALTIES:

- Band Saw Mill Machinery,
- Improved Rotary Saw Mills,
- with Green Mountain Dogs,
- Also Screw Post Dogs,
- Turbine Water Wheels,
- Power Feed Gang Edgers
- Buzz and Surface Planers,
- Heading Rounders,
- Stave Machines, Stave Jointers
- Stave Planers.

KENTVILLE, N. S.

THE DYMENT FOUNDRY CO.

BARRIE, ONT.

Manufacturers of

ENGINES, BOILERS, STEAM FEEDS

AND A COMPLETE LINE OF

SAW, SHINGLE AND
LATH MILL MACHINERY

Can ship mills in a week's notice. Write us
for prices and catalogue.

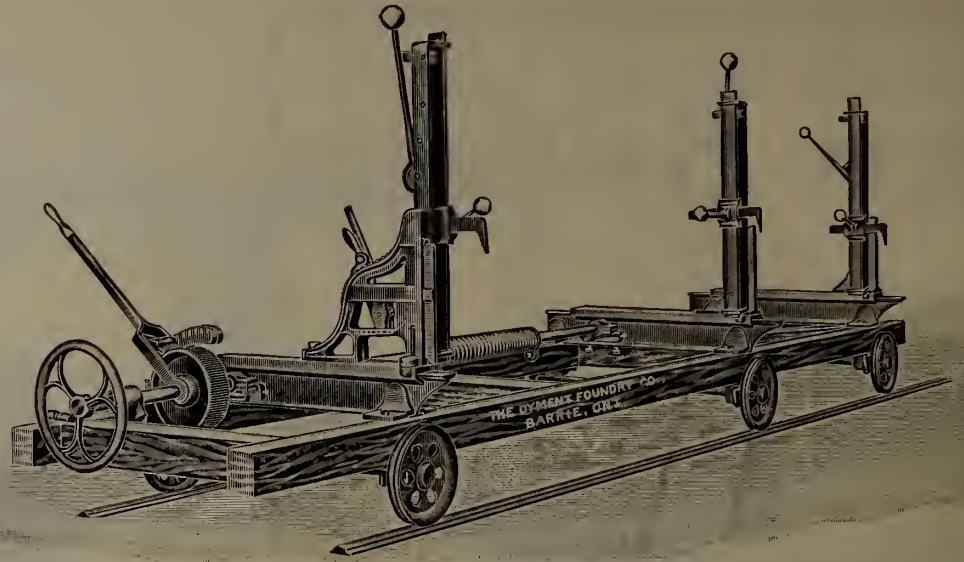

This is a light running Carriage and is quite suitable for small mills. Its capacity is about 15,000 feet per day. The wheels are 14 inches in diameter. The axles are $1\frac{3}{4}$ inches in diameter and go across frame. They are fitted with self oiling boxes. The bunks are of steel. Blocks will recede 38 inches. An overset lever is supplied when desired, also spring receder and band brake wheel.

The feed on this frame is self-contained and can be used for either rope or rack and pinion. All the frictions have 7 inch face, two of them are made of paper, the other two of iron. The mandrel is made of steel and is 3 7-16 inches in diameter. The mandrel pulley is made in different sizes so as to suit the speed and width of drive belt. If desired this pulley may be put inside of frame.

WE MANUFACTURE AN IRON SAW FRAME

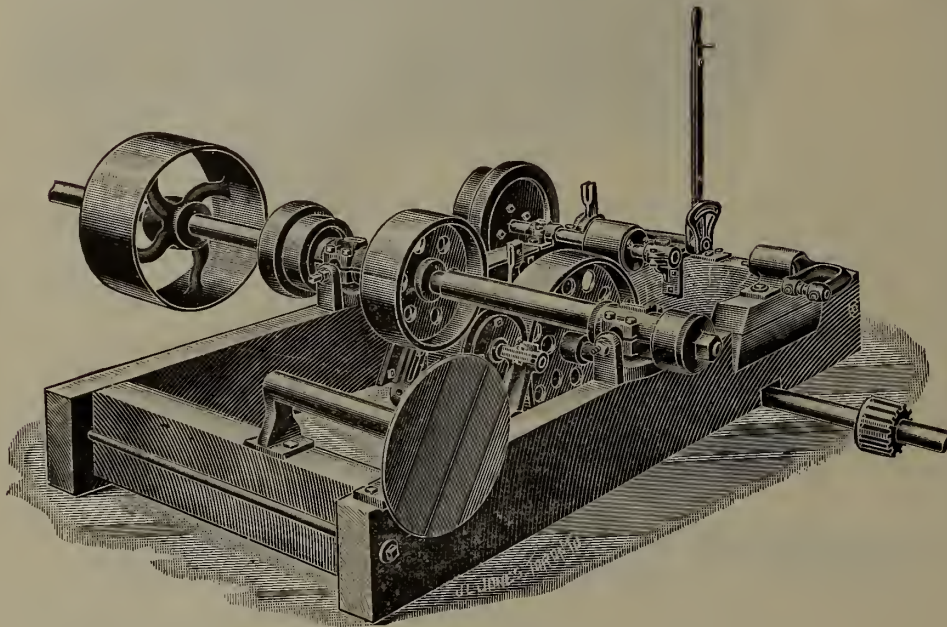

F. J. Drake's

SAW AND SHINGLE MILL MACHINERY

STATIONARY SAW MILLS
PORTABLE SAW MILLS
SHINGLE AND HEADING MACHINES
SHINGLE AND HEADING JOINTERS
TIE MILLS
LATH AND PICKET MACHINES
LATH BOLTERS
LOG JACKS AND CHAINS
SAW GUMMERS
DRAG SAW MACHINES
SHAFTING, PULLEYS, ETC.

*Complete Outfits of Mill Machinery
at Bottom Prices*

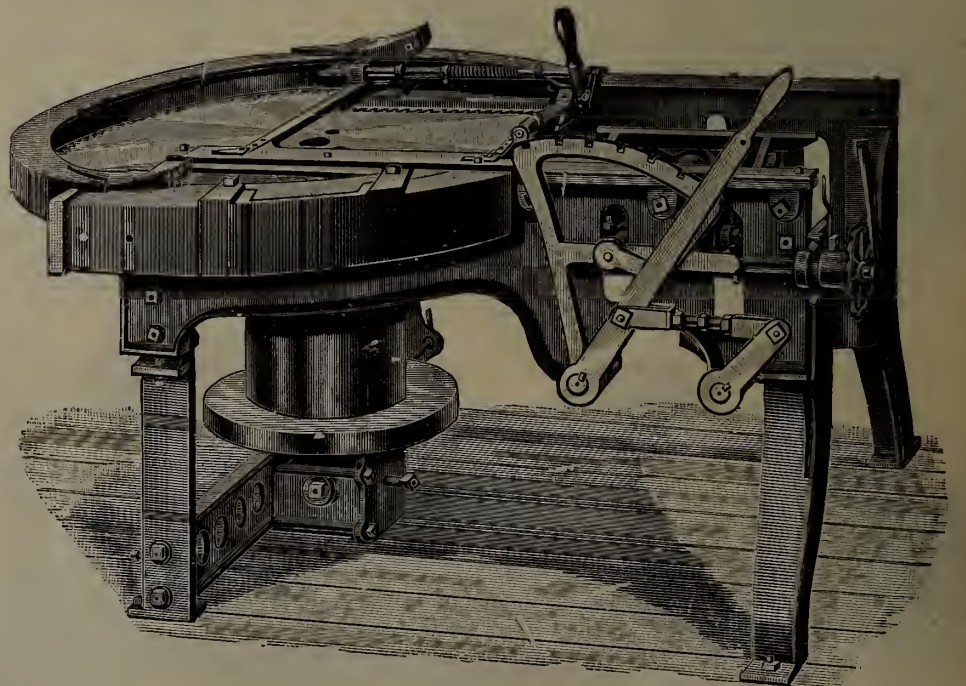

Capacity 25,000 to 50,000 per day.

F. J. Drake,

BELLEVILLE,
ONTARIO

Reliable Veterinary Remedies

No logging outfit is complete without a supply of reliable veterinary remedies. Getting the wrong kind means the loss of the use of your horses when time is valuable.

Johnson's Veterinary Remedies are guaranteed never to fail when used as directed. You get your money back if they ever do.

They are
Johnson's Horse Liniment No. 1.
A penetrating Alcoholic Liniment. Put up in one gallon jugs, with full directions, per imperial gal. \$4.50

Johnson's Horse Liniment No. 2.
A combination of the best oils used as liniments, imp. gallon . . . \$3.00

Johnson's Horse Colic Remedy.
A sure and speedy cure for colic Imperial gallon \$5.00

Johnson's Veterinary Healing Ointment.

Positively the best all-round healing ointment made. In use by the largest owners of horse flesh in Canada. Put up in 2 lb tins, each . . . \$2.00 or in ¼ lb tins, per dozen . . \$3.00

Johnson's Condition Powders. (Concentrated). Put up in bulk, per lb . . . 3c.

These goods being put up in bulk are more economical than others, as cost of bottling, etc., is saved.

CAMP REMEDIES.

In addition to our Veterinary Remedies we make a line of medicines for lumbermen, including a strong, penetrating liniment, healing ointment, cholera cure, liver pills, cough syrup, in fact anything in the form of Camp Drug Supplies. We know that there are no better remedies made than those we offer. There may be others nearly as good, but they lack our guarantee. Satisfaction or money back. A trade discount of 10% allowed off all orders amounting to \$100.

Send postal for printed matter.

A. H. JOHNSON
Wholesale Druggist
Collingwood, Ont.

MADE IN CANADA

STITCHED COTTON DUCK BELTING



SUPERIOR TO ALL OTHERS
—FOR—

Agricultural Machines, Elevators, Pulp and Paper Mills, Cotton, Wool-ten, Cement and Saw Mills, Machine Shops and Electric Powers.

MANUFACTURED BY

DOMINION BELTING COMPANY

Limited

HAMILTON, CANADA

USE OUR

"MAPLE LEAF BELT DRESSING"

IT'S OUT

Our New XXXX Catalog is just out, showing and describing the most complete and comprehensive line of Hand and Power Feed Shingle, Heading and Box Board Machinery ever created. This book is

YOURS FOR THE ASKING

and should be in the hands of every manufacturer of Shingles, Heading or Box Boards in the country. A postal request brings it.

PERKINS & CO.

GRAND RAPIDS, MICH.

STEAM NIGGER

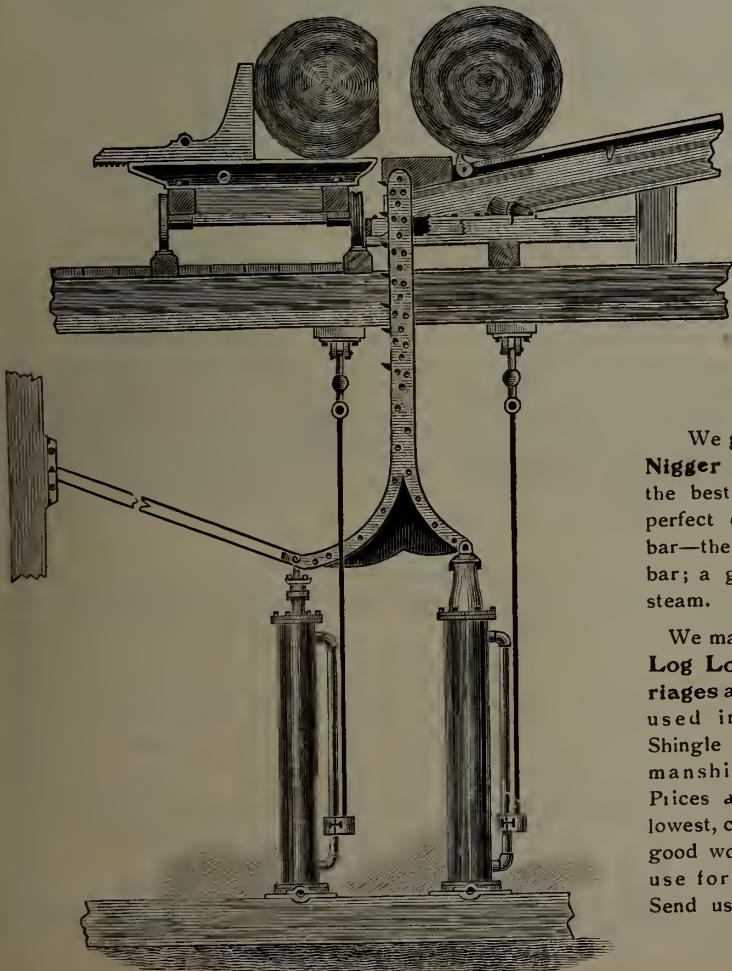

We guarantee this Nigger because it has the best valve made; perfect control of the bar—the best type of bar; a great saver of steam.

We make Kickers, Log Loaders, Carriages and everything used in a Saw or Shingle Mill. Workmanship guaranteed. Prices as low as the lowest, consistent with good work. Write to use for Catalogue. Send us your orders.

B. R. MOWRY & SONS,
Gravenhurst, Ont.

Gonnell & Dengler Machine Co.

ROCHESTER, N. Y

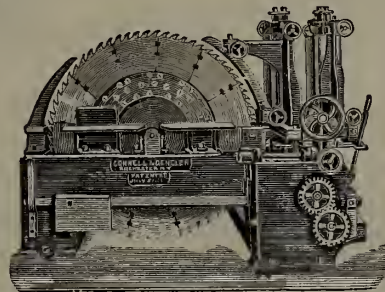

44 inch Circular Re-Saw.

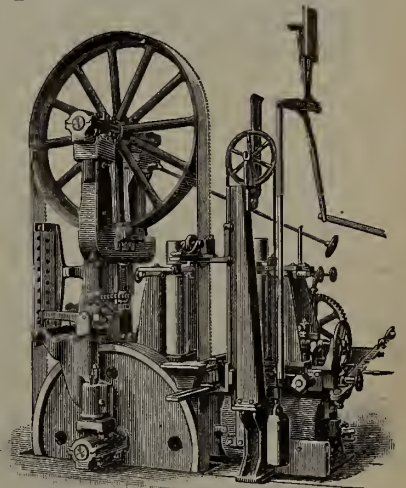

60 inch Band Re Saw

Manufacturers
of . . .

Box Makers' and Planing Mill Machinery

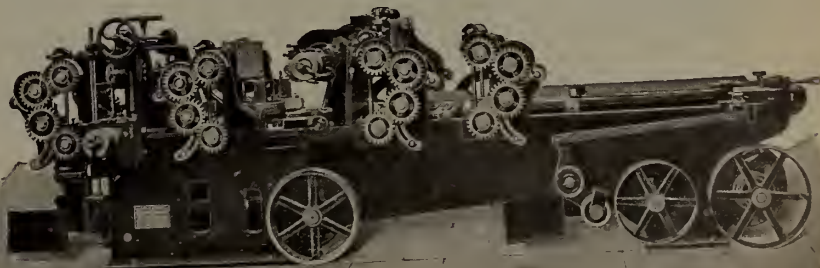

Heavy 25 inch Divided Roll Planer and Matcher with 8 Feed Roll.

Are You in Need
of a Good — **Double Surfacer**

A machine which will do first-class work on any grade of lumber.

IF SO, OUR **AMERICAN** NO. 50
26X8 INCHES **DOUBLE SURFACER** WILL FILL THE BILL

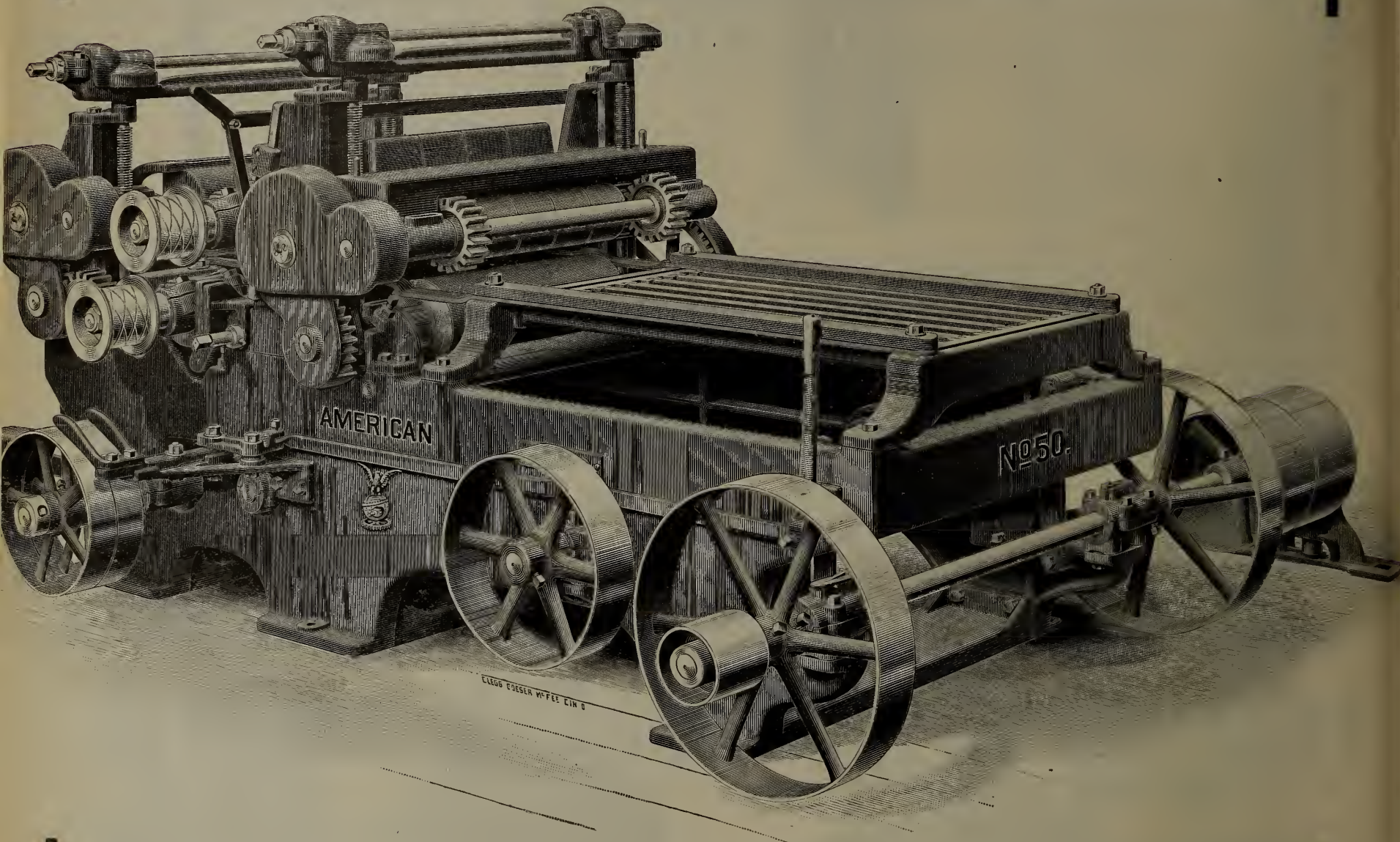

We have brought out this machine to meet a large demand for a Double Surfacer which will do first-class work on any grade of lumber. It is simple in construction with no parts to get out of order, and contains every late improvement.

It has Divided Roll and Chip Breaker, permitting the surfacing of unevenly sawed lumber, or two boards of different thickness at one time.

It has Four Feed Rolls, with strong, heavy, wide-faced Gears, which, together with belts of ample length, make it a rapid and powerful feeder.

The Upper and Lower Cutter Heads are close together, which permits the feeding of short pieces.

All parts of the machine are easy of access and all adjustments can be made quickly.

AMERICAN WOODWORKING MACHINERY CO.

NEW YORK, 136 Liberty Street.

THE A. J. BURTON SAW CO.

LIMITED
Vancouver, B. C.

Inserted-tooth, Shingle and Band

SAWS

File-room Machines and Tools,
Emery Wheels,
Silver Solder, etc.

BITS AND SHANKS

BRITISH COLUMBIA AGENTS FOR R. HOE & CO.

REPAIRS executed promptly by expert workmen.
INSERTED-TOOTH SAWS REMILLED & REFITTED.

WE ARE HERE ON THE GROUND.

SAVE FREIGHT AND DUTY
TRY US.

An I.C.S.=Made Architect

ASA A. GOBLE, R. R. No. 6, Huntington, Indiana, is another of the multitude that have found the I. C. S. "a savings bank of spare time." At the time Mr. Goble enrolled for the Building Contractors' Course of the International Correspondence Schools, of Scranton, Pa., he was earning an uncertain living by doing carpenter work in the farming districts of Indiana.



From the time of his enrolment, Mr. Goble's advancement has been steady and sure. Before he had gone far in his studies, he prepared plans and details for several buildings, the first being the United Brethren Church, a first-class brick-veneer structure, at Goblesville, Ind., the contract for which he won against several architects and builders of long experience.

"As a result of my Course," writes Mr. Goble, "I am besieged with people who desire to have up-to-date buildings erected, and I can obtain almost any price within reason for my services."

The story of Mr. Goble's success is the same as that of thousands of others who, desiring to better their condition, have used the I. C. S. as the medium to increase their income. What we have done for others we can do for you, if you are willing to devote a little of your spare time to our training.

Mark X before the position that interests you, fill in the coupon and send it to us. We will send you full particulars.

INTERNATIONAL CORRESPONDENCE SCHOOLS
Box 1001, Scranton, Pa.

Please send me your booklet "1001 Stories of Success," and explain how I can qualify for position before which I have marked X.

<input type="checkbox"/> Architect <input type="checkbox"/> Architectural Draft'g <input type="checkbox"/> Contractor & Builder <input type="checkbox"/> Building Inspector <input type="checkbox"/> Mechanical Engineer <input type="checkbox"/> Mechanical Drafts. <input type="checkbox"/> Electrical Engineer <input type="checkbox"/> Dynamo Tender <input type="checkbox"/> Telephone Engineer <input type="checkbox"/> Steam Engineer <input type="checkbox"/> Civil Engineer <input type="checkbox"/> Surveyor	<input type="checkbox"/> Sanitary Engineer <input type="checkbox"/> Chemist <input type="checkbox"/> Ornamental Designer <input type="checkbox"/> Bookkeeper <input type="checkbox"/> Stenographer <input type="checkbox"/> Show-Card Writer <input type="checkbox"/> Ad Writer <input type="checkbox"/> French } With <input type="checkbox"/> German } Edison <input type="checkbox"/> Spanish } Phonograph <input type="checkbox"/> Commercial Law <input type="checkbox"/> Civil Service Exams.
---	--

Name _____

St. & No. _____

City _____ State _____

The Shimer Gutter Heads

WITH EXPANSION

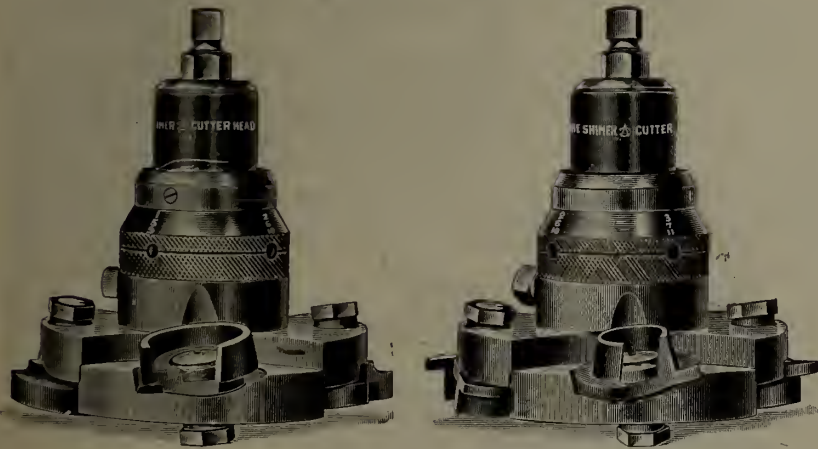

Are built from forgings of Steel and finished throughout in the solid metal. This insures accuracy, durability and perfect mechanical adjustments.

They are appreciated by the user because they hold up under the severest tests. They cut easily all kinds of hard, knotty and cross-grained lumber. If you make single tongue and groove Flooring, Ceiling and Wainscoting, buy THE SHIMER CUTTER HEADS and you will have no disappointment. Address

SAMUEL J. SHIMER & SONS
Milton, Pennsylvania

THE BEST IN THE WORLD

There is no doubt about the fact that the

RODGERS

Adjustable Log Siding Machine

is without a peer.

This machine will slab opposite sides of a log in one operation at the rate of two thousand logs in 10 hours.

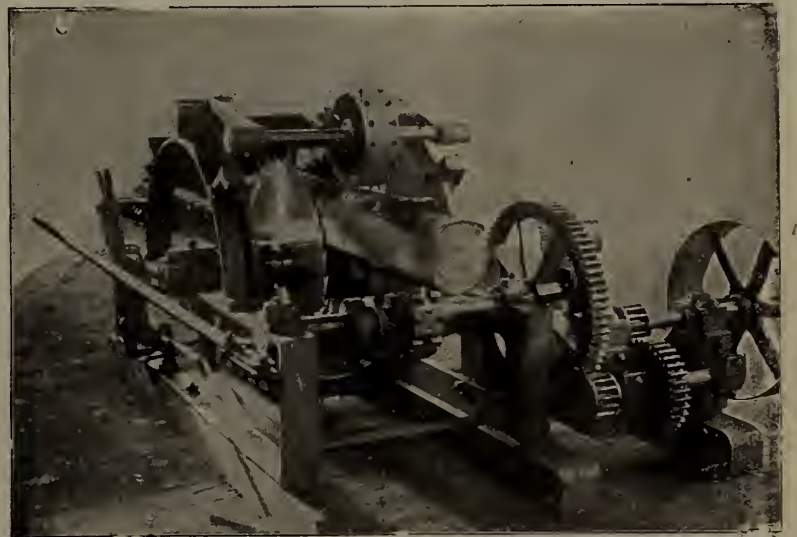

A MONEY MAKER

A MONEY SAVER

HUNDREDS OF LETTERS RECEIVED LIKE THIS :

Rock Island, Ill., Nov. 25, 1902.

RODGERS IRON MANUFACTURING CO., Muskegon, Mich.

Gentlemen:—Replying to yours of recent date and referring to your adjustable log siding machine, must say it has given us general satisfaction, and we have done good work with it. Any one desiring a machine of this style for the purpose of slabbing small logs, we would recommend yours. Respectfully,

WEYERHAUSER & DENKMAN.

For full particulars and literature, mention this paper and address :

RODGERS IRON MFG. CO.
MUSKEGON, MICH.

Detachable Chain Belt

—AND—

CONVEYING

MACHINERY



William R. Perrin & Company Limited

TORONTO, CANADA.

A. F. BARTLETT & CO.

Manufacturers of and Dealers in

Engines, Boilers

Saw Mill Machinery

Etc.

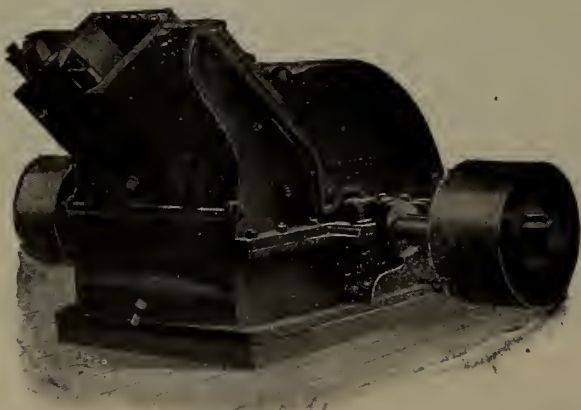

This is our Saw Mill Hog or Edging Grinder

If you have no Hog write us for circulars and let us tell you all about ours. They save their cost in a short time. Write for our Stock List of New and Second Hand Machinery.

A. F. BARTLETT & CO. Saginaw, Mich.

FRANK DENTON, K. C. HERBERT L. DUNN
W. MULOCK BOULTBEE.

DENTON, DUNN & BOULTBEE
Barristers, Solicitors, Notaries, etc.
National Trust Chambers. TORONTO

OILS

Manufacturers High-grade Cylinder, Machine and Sawmill Oils.

Calypsol Grease

for Sawmill Purposes a Specialty. Our products are made from finest Pennsylvania stocks.

We solicit your correspondence.

St. John St., MONTREAL. Commercial Oil Co.,
Offices and Works: Manchester, Eng. Hamilton, Ont.
Hamburg, Germany. Newark, N. J. Chicago, Ill.



Sole Canadian Agents - Prices Reduced
WATEROUS, BRANTFORD, CANADA

Please mention this paper when corresponding with advertisers.

SHERMAN'S FLOORING MACHINES

PATENTED

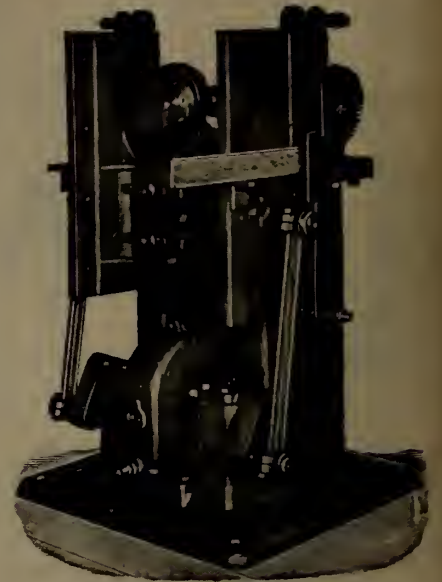

Above cut shows our End Matcher, the best machine in the market for end matching flooring strips. They do rapid and accurate work, and are durable—therefore used by leading flooring manufacturers. Make your flooring profitable by end matching it.

We Make the

SHERMAN SIDE BORING MACHINES

and the

SHERMAN FACE BORING MACHINES

To bore flooring while it is being run on the flooring machine. Write for circular and list of users.

W. S. SHERMAN CO.

1150 Holton St., Milwaukee, Wis

WOODWORKERS SAY
"The convenience to the Sawyer and the saving in lumber make the **STANDARD AUTOMATIC SAW GUAGE** an article of much merit."

WRITE TO
SPECIALTY MFG. CO.
DETROIT Mich.

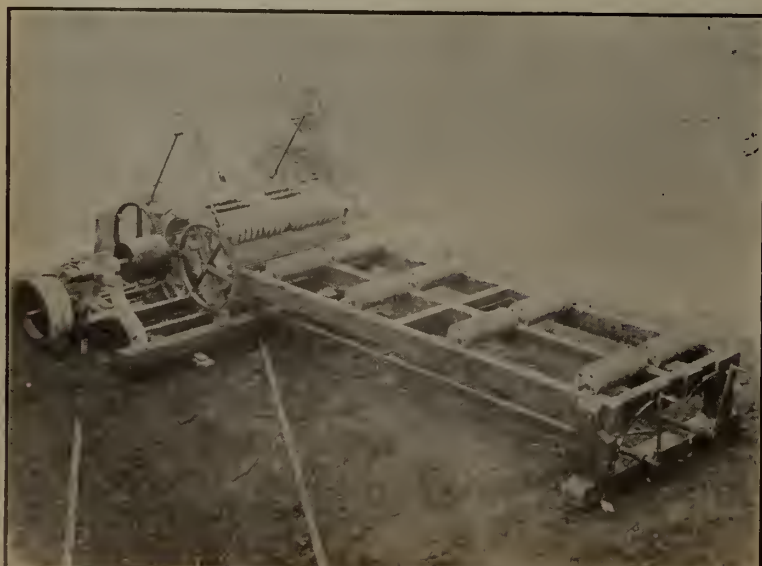

OXFORD FOUNDRY AND MACHINE CO.

OXFORD, N. S.

OUR SPECIALTY IS

SAW MILL MACHINERY

We Have Filled Orders from the Pacific Coast of B. C. to Labrador. * * *

WRITE AND LET US GET ACQUAINTED

Perfect Swing Shingle Mill

Fitted with our "Automatic Trip."

Best Swing Shingle Machine on the Market today for cutting Shingles, Headings, Etc. . .

It will pay you

to write for description and price before placing your order.

We also Manufacture a complete line of . . .

SAW MILL MACHINERY, ENGINES AND BOILERS

THE
Owen Sound Iron Works Co.
LIMITED

Owen Sound, Ont.

SEND FOR CATALOGUE

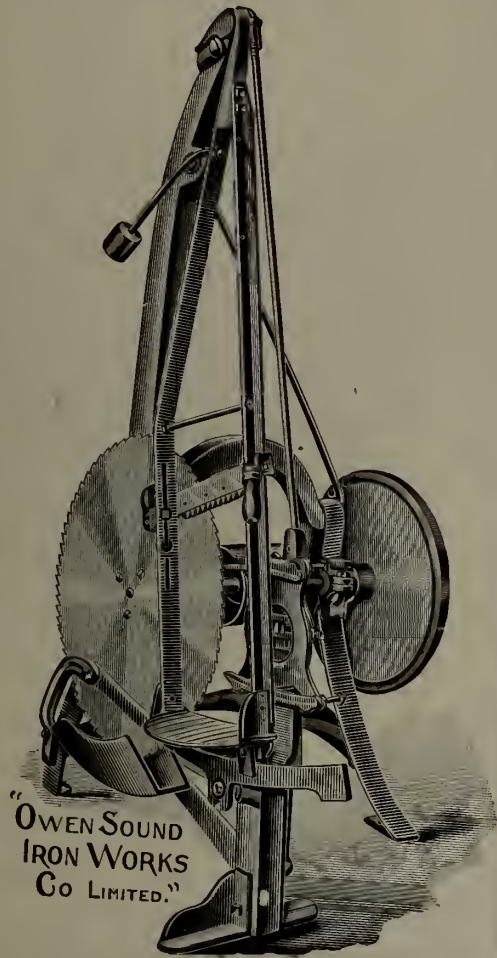

"OWEN SOUND IRON WORKS CO LIMITED."

RUBBER BELTING

For
Transmitting
Elevating
and
Conveying



Rubber
Hose
for
Water
Steam
Air
Suction
Fire
Protecti n

THE GUTTA PERCHA & RUBBER MFG. CO.
OF TORONTO, LIMITED.

TEMPORARY OFFICES: 15 EAST WELLINGTON STREET, TORONTO, CAN.

Branches: Montreal, Winnipeg.

IMITATED BUT NEVER EQUALLED

40,000
Running in
Every Kind
of Timber



Perfect
in Material,
Workmanship
and Temper

GET THE GENUINE HOE CHISEL-TOOTH SAW

MADE ONLY BY

R. HOE & CO., 504 to 520 Grand Street, NEW YORK, N. Y., U.S.A.

New 200 Page Green Book

1904 EDITION.

"Saw and Knife Fitting Machinery and Tools"

MAILED FREE ON REQUEST.

A Book for Mill and Factory Managers, Superintendents, Foremen and Saw Filers.

BALDWIN, TUTHILL & BOLTON,

GRAND RAPIDS, MICH., U.S.A.



B. T. & B. Full Automatic Knife Grinder. Style D

SAW AND KNIFE FITTING

THE NEW B. T. & B. MANUAL

Revised edition. 144 pages. Copiously illustrated and Durably Bound. Is an exhaustive treatise on the care of Saws and Knives.

A Practical Book for Saw Filers.

Mailed Postpaid on Receipt of Price \$2.00

THE "B. T. & B." LINE

NEED ANYTHING?

- Sharpeners, Swages,
- Stretchers, Shapers,
- Side Files, Shears,
- Retoothers, Brazing Machines, Filing Clamps, Lap Grinders, Lap Cutters, Patch Machines, Crack Drills, Hammering Benches, Bench Grinders, Band Filers, Band Setters, Pulleys and Stands, Brazing Forges, Saw Sets, Saw Gauges, Swage Bars, Upsets, Straight Edges, Tension Gauges, Back Gauges, Leveling Blocks, Anvils, Hammers, Speed Indicators, Emery Dressers, Knife Grinders, Knife Balances, Shingle Saw Grinders, Burr Gummers, Post Brackets, Stretcher Bench Brackets, Cutters, Marking Stamps, Saw Guides, etc.

Andrews

Stands for

Three Comforts

Quality Efficiency Price



Kilns That Dry Your Lumber
Without Drying Up Your Bank Account

Write for Catalogue

The A. H. Andrews Co.

174-176 Wabash Avenue CHICAGO, U. S. A.

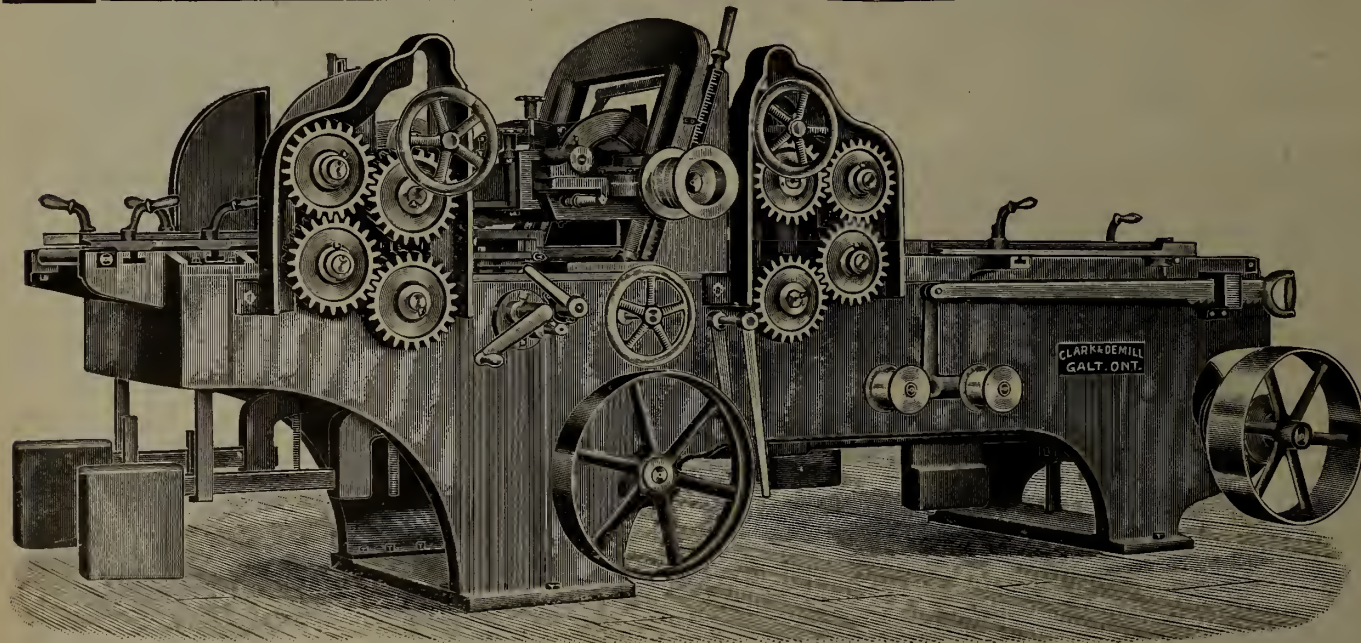

Our No. 72 LIGHTNING PLANER AND MATCHER

Kindly note that we make this machine in different sizes, single or double cylinder, as desired. Parties desiring thoroughly up-to-date machinery will find it to their advantage to write us before placing their order.

Write for new Catalogue.

Clark & Demill Galt, Ont.

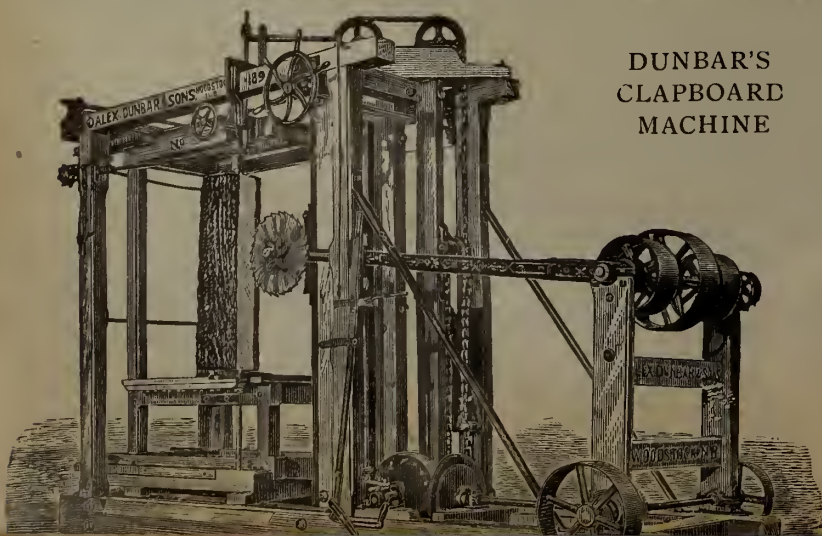

DUNBAR'S
CLAPBOARD
MACHINE

ALEX. DUNBAR & SONS

Woodstock, N. B.

Manufacturers of



Saw Mill Machinery

OF ALL KINDS

Including ROTARY SAW MILLS (3 sizes), CLAPBOARD SAWING MACHINES, CLAPBOARD PLANING AND FINISHING MACHINERY, SHINGLE MACHINES, STEAM ENGINES, Etc.

WRITE FOR FURTHER PARTICULARS

NATURAL DRAFT MOIST AIR . . . DRY KILNS

LUMBER TRUCKS and TRANSFER CARS

Write for prices and particulars of the most simple and efficient Natural Draft Dryer on the market. Testimonials and list of users sent on application. Every square inch of heating surface is utilized to the uttermost and perfect ventilation and circulation is obtained by a very simple arrangement of ducts. Write for particulars to

SHELDON & SHELDON,
GALT, ONT.

FORMERLY McEACHREN HEATING & VENTILATING CO.

VIRGIN METALS ONLY

enter into the composition of

"MIDLAND" BEARING METAL

There is not an ounce of scrap or dross in it, and you have the full wearing life of the Metal guaranteed to you. This makes the metal

A MONEY SAVING PROPOSITION

to you, and we would be glad to have you test it for yourself at 15 cts. per pound.

GEORGIAN BAY ENGINEERING WORKS
MIDLAND, ONT.

The Dry Kiln That's Nearest Perfection

In adaptability to successfully meet the special requirements of every variety of lumber—

In maximum capacity of satisfactory drying—

In permanence of construction and exclusive features of superiority—

In simplicity and ease of operation—

IS

THE STANDARD DRY KILN

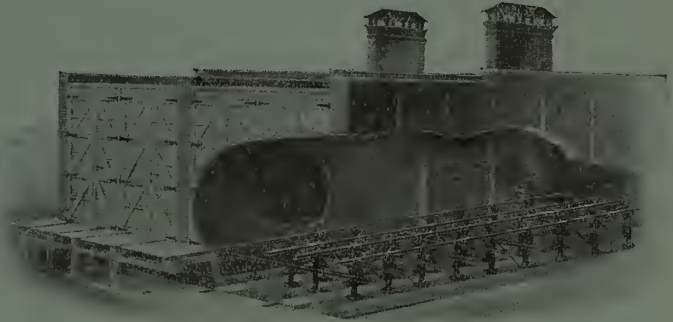

Our Catalogue "D" goes into details on all these points, and contains expressions of satisfaction from saw and planing mill people IN YOUR VICINITY who will be pleased to correspond with you directly regarding the results they are obtaining from The Standard Moist Air Drying System.

Tell us to send you the catalogue—and then you write them.

The Standard Dry Kiln Co.
Indianapolis, Indiana



FOR

DRY KILNS

that will season lumber of all kinds and under all conditions, whether partially air-seasoned or green from the log, in shortest time and at least cost, entirely free from checking, warping or case hardening,

Write to—

McEACHREN HEATING & VENTILATING COMPANY, GALT, CANADA.

**"Do To-day's Work This Morning---
To-morrow's This Afternoon."**

Equip your Shaping Machines with OUR

SOLID STEEL SHAKER CUTTERS

They CUT FREE and EASY in all kinds of stock, and RETAIN THEIR ORIGINAL FORM UNTIL WORN OUT. "Always Ready for Use."

Send for Catalogue.

FURITURE CITY TOOL CO.

Makers of WOOD WORKING TOOLS

189 Campau Street.

Grand Rapids, Mich., U. S. A.



HUTHER BROS. PATENT GROOVER OR DADO HEAD
For cutting any width groove from 1/4-inch to 2 inches or over

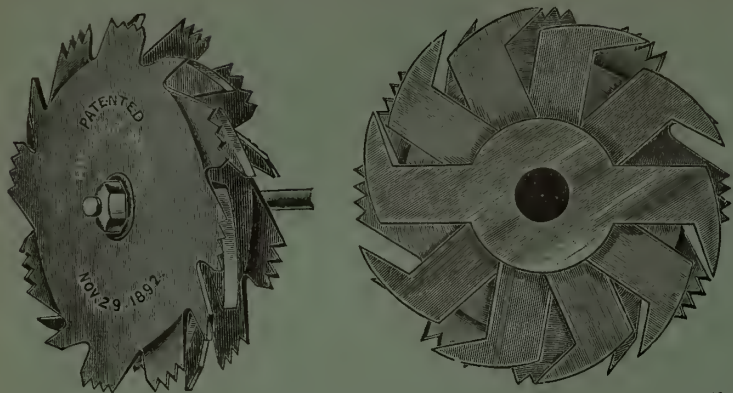

Can be used on any Circular Saw Mandrel. Will cut a perfect groove with or across the grain. This is the only Dado Head on the market that gives entire satisfaction on all classes of work. No screw adjustment. For different width grooves, simply remove or add inside cutters. Sold by builders and dealers of wood working machinery in all parts of the United States. Will send on approval, in competition with any other make on the market; if not the best return at our expense HUTHER BROS., Platt Street, ROCHESTER, N. Y., manufacturers of Circular Saws, Morgan Pattern Lock-Corner Box Cutters, Concave Saws, etc.

Steam, Power
and
Centrifugal Pumps,
Condensers,
Travelling Cranes.



Stock Carried in:
HALIFAX,
MONTREAL,
HAMILTON,
WINNIPEG,
VANCOUVER.

THE SMART-TURNER MACHINE CO., LIMITED
HAMILTON, ONTARIO

SEND FOR **H. W. PETRIE'S**
MONTHLY STOCK LIST
NEW & 2ND HAND MACHINERY
TORONTO, CANADA

DO YOU USE
Number **128** Tacks'

ACTUAL SIZE

We make them, also Steel Log Hammers and Stamps, Brass Stencils and Stencil Inks.

HAMILTON STAMP & STENCIL WORKS,
HAMILTON, ONT.

CRESCENT MACHINERY

Quality is all right.
So's the price.

Band Saws
Jointers
Saw Tables

Very low price on
BAND SAW BLADES

Catalogue tells the rest.

H. W. PETRIE

Dept. C. M.
TORONTO, ONT.

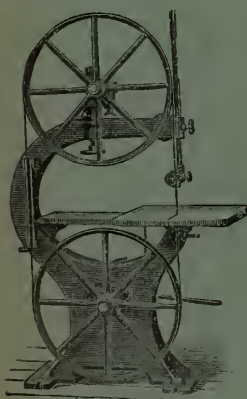

RIGE LEWIS & SON,
Limited

S
A
W
S

Chain
Bolts
Files

Steel
Iron
Horse Shoes

A
X
E
S

Peaveys
Pike Poles
Cant Hooks

Boot Calks
Lumber Leads
Timber Grips

R
O
P
E

TORONTO.

Write for Prices

THE
LEATHER
BELT
THAT'S
KNOWN
OUR
"EXTRA"



MONTREAL
WINNIPEG

TORONTO
VANCOUVER

PINK LUMBERING TOOLS

The Standard Tools

In Every Province of the Dominion, * * * * *
* * * * * New Zealand, Australia, Etc.



Pink Round Bill Peavey, Handles in Split Maple



Pink Duck Bill Winter Cant Hook, Handles in Split Maple.

FINEST QUALITY
SPLIT MAPLE
CANT HOOK AND

Boom Chains,
Pike Poles,

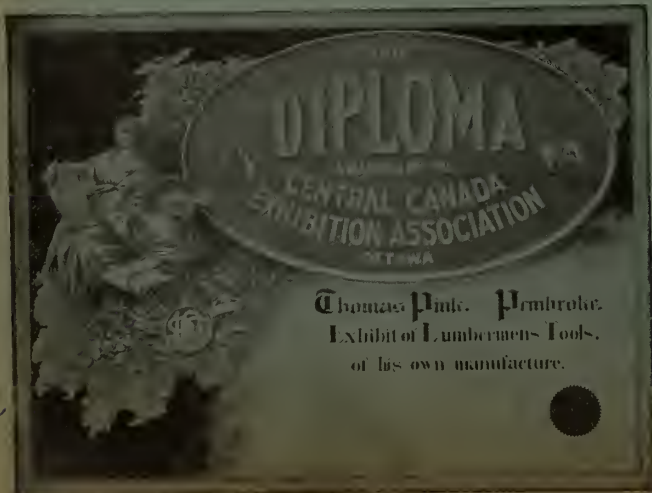

THE CANADA LUMBERMAN AND WOOD-WORKER

VOLUME XXV. }
NUMBER 4.

TORONTO, MONTREAL, WINNIPEG, CANADA, APRIL, 1905

{TERMS, \$1.00 PER YEAR
{Single Copies, 10 Cents.

PAT. OSCILLATING BOB SLED KNEE
Hauls 25 per cent. easier, and wears longer, and is lighter than all others.
THOMPSON MFG. CO., Ltd.,
Grand Bay, N. B.

JNO. S. FIELDING, C. E.
WATER POWERS AND DAMS
Room 2, 15 Toronto Street - TORONTO

FIRE NOTICE

We are pleased to inform our customers that the fire on the 3rd inst. did not destroy any of our works except the tower used in painting Screen Cloth. All other departments have been and are running as usual. Orders for Screen Cloth will be filled promptly from stock in Hamilton and Montreal.

THE B. GREENING WIRE COMPANY, LIMITED

The Ottawa Saw Co. LIMITED
Middle Street, OTTAWA, ONT.
Sandvik Swedish Steel
Band, Gang and Circular Saws
P. M. FEENY, Manager.

A Good Thing
A good thing is always worth the money. This is true of our belting.
J. L. GOODHUE & CO.,
DANVILLE, QUEBEC.

WOODS LIMITED
Wholesale Manufacturers of . .
LUMBERMEN'S AND CONTRACTORS' SUPPLIES
INCLUDING
Tents, Flags, Awnings, Tarpaulins, Clothing, Overalls, Shirts, Mitts, Underwear, Blankets, Axes, Moccasins, Woods Celebrated Eider Down Sleeping Bags
WOODS BUILDING - OTTAWA, CAN.

DICK'S BELTINGS

Never is affected by wetness, and does not stretch
Excels in Transmission Power
Always Uniform.
LARGE STOCK ON HAND

WRITE TO SOLE AGENTS:
J. S. YOUNG, 413 St. Paul Street MONTREAL

D. K. McLaren
GENUINE
Oak Belting
MILL SUPPLIES
751 Craig St., Montreal.
152 Bay St., Toronto.

SPRAYERS

NOW IS THE TIME
to get your buildings fixed up for the season. Cut down your Insurance and Labor Bills with a "BUCKEYE" SPRAYER.
Send for Catalogue
W. H. C. MUSSEN & CO., MONTREAL

FOR PAINT, WHITWASH ETC.

THE E. R. BURNS SAW CO.

TORONTO, ONT.

MANUFACTURERS OF HIGH-GRADE

Circular and Long Saws
UNEXCELLED
SHINGLE SAWS

OUR INSERTED TOOTH SAWS POSITIVELY THE BEST



The Wm. Hamilton Mfg. Co., Limited

Builders of a Complete Line of

SAW MILL MACHINERY

We are specialists in the building of sawmill machinery—we have been making it, and making it well, for nearly fifty years.

Surely our machines must have merit—must have lived up to all our claims, or we would not be in business to-day.

Back of every machine we sell is our guarantee against its failure due to defective material or workmanship, and our warranty of its successful operation.

All our machines are of simple design and enduring construction.

We are specially well equipped for handling repair jobs, and can give your orders prompt attention.

Can we not send you our catalogues?
Write Department L for them.

Our Line Includes

Engines and Boilers
 Band Mills
 With Weight or Steam Tension
 Gangs
 Carriages
 Husk Frames
 Log Handling Machinery
 Edgers
 Trimmers and Slashers
 Steam, Hand and
 Power Set Works
 Lath Mill, Shingle Mill
 and Filing Room Machinery
 Twin Circulars
 Tie Mills
 Burners

Head Office and Works: PETERBOROUGH, ONTARIO

Allis-Chalmers-Bullock LIMITED

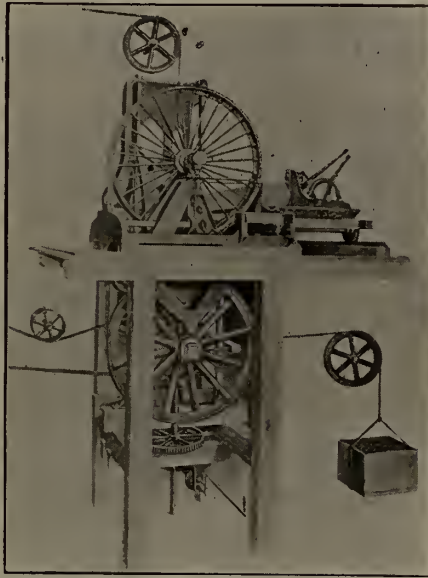

NEW ALLIS DOUBLE CUTTING TELESCOPIC BAND MILL

UP-TO-DATE SAW MILL MACHINERY

Builders in Canada of the Celebrated Machinery of Allis-Chalmers Co., Milwaukee; Bullock Electric Manufacturing Co., Cincinnati; Ingersoll-Sergeant Drill Co., New York; Lidgerwood Mfg. Co., New York.

WORKS : MONTREAL.

BRANCH OFFICES : HALIFAX, TORONTO, WINNIPEG, VANCOUVER, NELSON

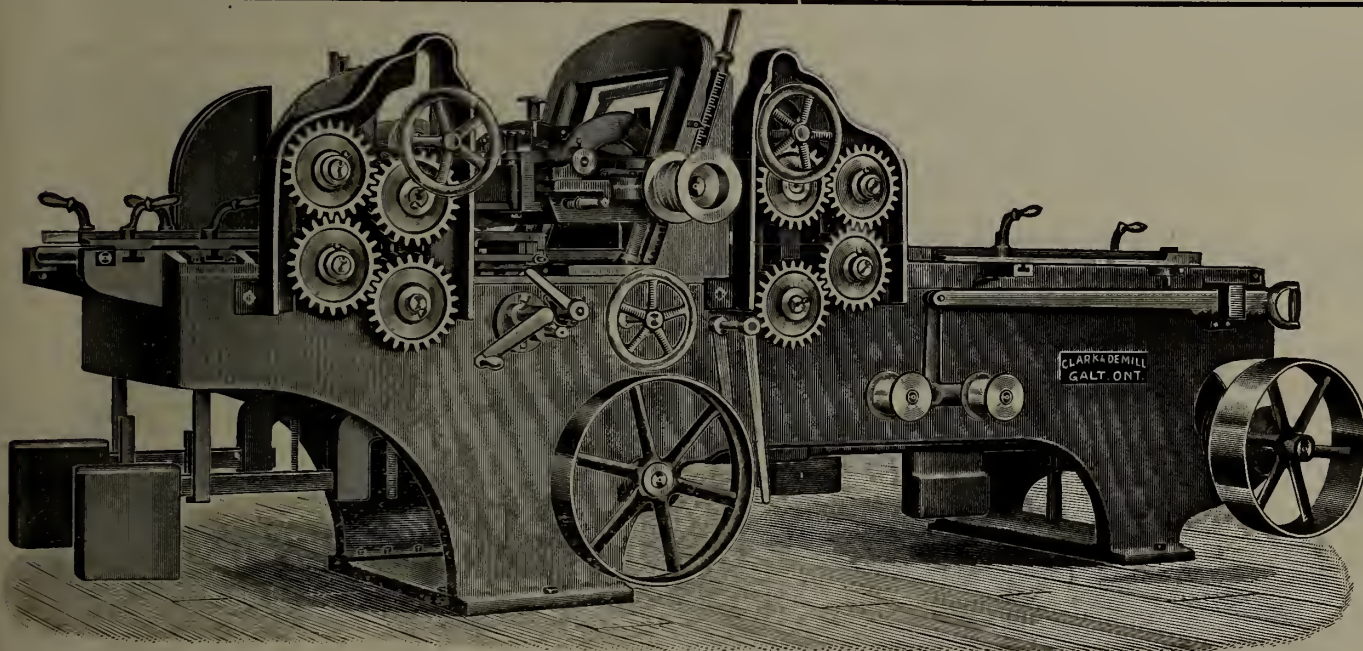

Our No. 72 LIGHTNING PLANER AND MATCHER

Kindly note that we make this machine in different sizes, single or double cylinder, as desired. Parties desiring thoroughly up-to-date machinery will find it to their advantage to write us before placing their order.

Write for new Catalogue.

Clark & Demill
Galt, Ont.

How About Wood Split Pulleys?

When making your spring alterations in your mill you will doubtless require some Wood Split Pulleys. If you want to get the best wood split pulley manufactured to-day make your order read—

FAIRBANKS WOOD SPLIT PULLEYS

Study the cut. The web construction built in the rim not only strengthens the entire pulley but makes it impossible for the rim to work loose at the arm. Each segment is glued and nailed with three coated nails to the next one. Four point bushings are used, giving twice as much grip on the shaft as in the usual two point bushings. Write us.

THE CANADIAN FAIRBANKS COMPANY, LIMITED

MONTREAL

TORONTO

VANCOUVER

WINNIPEG



BRITISH COLUMBIA LUMBER AND SHINGLE MANUFACTURERS

The Canadian Pacific Lumber Co., Limited
PORT MOODY, B. C.

Manufacturers and Wholesale Dealers in All Kinds of **B. C. LUMBER, LATH, MOULDINGS, ETC.**

The Largest Shed and Dry Kiln Capacity of any Mill in British Columbia. Special Attention Given to Orders from Manitoba and the Territories.



Long Distance Telephone Connection.



Address the Company at Port Moody or **BYRNES & CUDDY, Selling Agents, WINNIPEG**

CLOVERDALE MILLING CO., CLOVERDALE, B. C.

== Red Cedar Shingles ==

OUR SPECIALTY

SECOND TO NONE

CORRESPONDENCE SOLICITED

PETER LUND, Managing Director.

J. BRECKENRIDGE, President.

MANUFACTURERS OF ALL KINDS OF

Grows Nest Pass Lumber Co., Limited
WARDNER, B. C.



BUILDING MATERIAL

Capacity 150,000 Feet Per Day.

THE KING LUMBER MILLS, LIMITED, GRANBROOK, B. C.

Manufacturers of

Building Materials

And All Kinds of DIMENSIONS, FLOORING, CEILING and BASE and CASE MOULDINGS

Columbia River Lumber Company, Limited

HEAD OFFICE AT GOLDEN, B. C.

Largest Capacity in Mountains

MILLS AT { GOLDEN, B. C.
BEAVER, B. C.
KAULT, B. C.
CARLIN, B. C.

ROUGH AND DRESSED

MANUFACTURERS OF ALL KINDS OF

LUMBER

FIR, SPRUCE
CEDAR AND PINE

LATH

Telephone Poles, Piling, Etc., a Specialty.

The Fernie Lumber Co., Limited, Fernie, B. C.

MANUFACTURERS OF AND DEALERS IN ALL KINDS OF

ROUGH AND DRESSED LUMBER

Dimension and Bridge Timber a Specialty.

Moulding in Stock or Made to Order.

H. CAMERON, Manager.

DONALD GRANT, President.

Moyie Lumber & Milling Co., Limited, Moyie, B. C.

Manufacturers and Dealers in All Kinds of

FLOORING, CEILING, SIDING, SHIP LAP, COMMON BOARDS, DIMENSIONS AND LATH

Specialty: **MOUNTAIN TAMARAC**

JOS. GENELLE, Manager.

J. G. BILLINGS, Secretary.

THE YALE-COLUMBIA LUMBER COMPANY, LIMITED

Head Office: NAKUSP, B. C.

Mills at Nakusp, Westley and Cascade, B. C.

MANUFACTURERS OF

DEALERS IN

All Kinds Rough and Dressed Lumber, Mouldings, Lath, Etc.



Cedar and Fir Piles, Telephone and Telegraph Poles, Fence Posts, Etc.

BRITISH COLUMBIA LUMBER AND SHINGLE MANUFACTURERS

D. & J. HADDEN, CLOVERDALE, B.C.

MANUFACTURERS AND DEALERS IN THE HIGHEST GRADE

LUMBER AND RED CEDAR SHINGLES

Send your orders to the above firm, who can supply you with shingles that cannot be beaten for quality and prices.

Agent for Ontario : Woodstock Lumber and Manufacturing Co., Woodstock, Ont.



THE PIGEON RIVER LUMBER COMPANY PORT ARTHUR, ONT.

MANUFACTURERS OF

Band Sawed White Pine Lumber, Lath, Pine and Cedar Shingles,

are operating their extensive plant night and day, to keep abreast with orders.

THERE IS A REASON—

A trial order will tell you why.

Winnipeg Representative,

D. J. McDONALD, Clarendon Hotel.

J. A. SAYWARD

MANUFACTURER OF AND DEALER IN

Cedar and Spruce Lumber

Shingles, Lath, Spars, Etc.

ORDERS CAREFULLY EXECUTED
PROMPT SHIPMENTS

VICTORIA, B. C.

THE BRITISH COLUMBIA MILLS, TIMBER & TRADING COMPANY

Head Office : VANCOUVER, B. C.

Winnipeg Office : Merchants Bank Building P. O. Box 235

MANUFACTURERS OF

BRITISH COLUMBIA FIR, CEDAR and SPRUCE—both Rough and Dressed. Sash, Doors, Mouldings. Lath and the Highest Grades

"ROYAL CITY BRAND"

RED CEDAR SHINGLES

DOUGLAS FIR TIMBER

All Widths and Thicknesses up to 120 feet in Length Supplied on the Shortest Possible Notice.

OWNERS AND OPERATORS OF

HASTINGS SAW MILL - VANCOUVER, B. C.
ROYAL CITY SAW MILL, VANCOUVER, B. C.

ROYAL CITY SAW MILL, NEW WESTMINSTER, B. C.
MOODYVILLE SAW MILL - BURRARD INLET, B. C.

Total Capacity, 400,000 Feet of Sawn Lumber per Working Day of Ten Hours.

The Ladysmith Lumber Co., Limited

LADYSMITH, B. C.

Manufacturers of

LUMBER, LATH, SHINGLES,
MOULDINGS, ETC.

SPECIALTY: The best Cedar Shingles manufactured on the Coast.

FRESH WATER FIR LATH ALWAYS IN STOCK.

Capacity of Shingle Mill, 100,000 per day of 10 hours.

Correspondence Solicited

BRITISH COLUMBIA LUMBER AND SHINGLE MANUFACTURERS

North Star Lumber Co., Limited, Cranbrook, B. C.

Manufacturers of **PINE, FIR and TAMARAC LUMBER**

Specialty: Heavy Timber and Piling

BIG BEND LUMBER CO., LIMITED, ARROWHEAD, B. C.

Manufacturers of **Lumber, Lath and Shingles**

CORRESPONDENCE SOLICITED

EAST KOOTENAY LUMBER CO., LIMITED

Capacity 150,000 feet per day.

Saw and Planing Mills at RYAN, CRANBROOK and JAFFRAY.

— WE MANUFACTURE —

**TAMARAC
PINE and FIR**

FOR THE NORTH-WEST TRADE

Send us your orders if you want dry stock.

Head Office: CRANBROOK, B. C.

D. B. GRANT.

T. W. KERR

DELTA SAW MILL CO.

MANUFACTURERS OF

Rough & Dressed Lumber, Lath, Shingles,
Fence Pickets, Doors, Sash, Mouldings,
Salmon and Fruit Boxes, and Round Tanks

Correspondence Solicited. - - LADNER, B. C.

Mouldings

Shingles

VICTORIA LUMBER AND
MANUFACTURING CO., LIMITED

MILLS AT CHEMAINUS, B. C.

FIR AND GEDAR LUMBER

of all descriptions, in straight or mixed cars.

We can supply large and long timbers, but
don't care to ship anything over 40x40x140
feet long. : : : : :

Prompt Shipments
Good Quality and Manufacture
Long Lived Timber

ADDRESS—

CHEMAINUS, B. C.

Please mention this paper when corresponding with advertisers

Galt Machine Knife Works



MACHINE KNIVES OF EVERY DESCRIPTION
FOR **Woodworking Machines**
... Send for Price List ...
The Peter Hay Knife Co., Limited - Galt, Ont.

Gonnell & Dengler Machine Co.

ROCHESTER, N. Y.

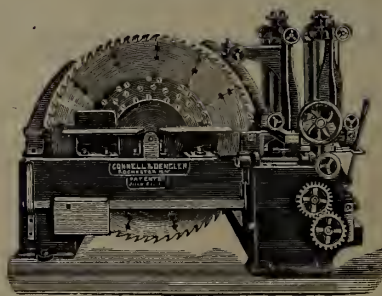

44 inch Circular Re-Saw.

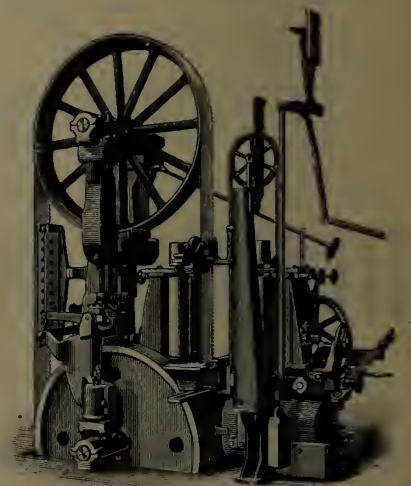

60 inch Band Re-Saw

Manufacturers
of . . .

Box Makers' and
Planing Mill Machinery



Heavy 26 inch Divided Roll Planer and Matcher with 8 Feed Roll

Moreau's Pulpwood Barking Machine

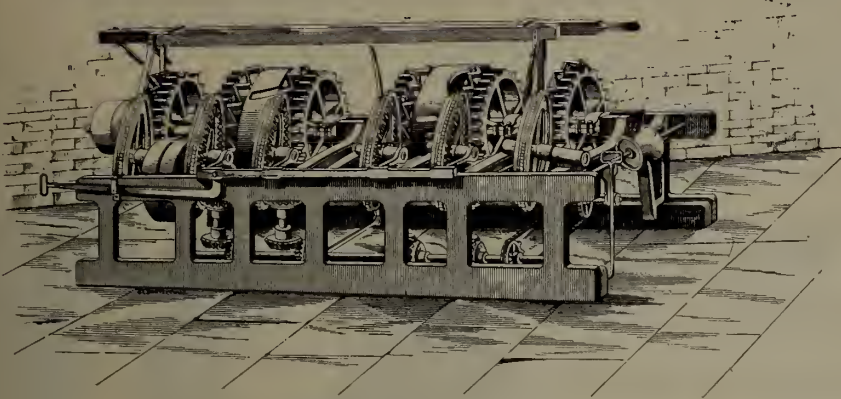

WEIGHT 4,200 LBS.

Latest and best Pulpwood Barking Machine. Requires about 7 h. p. to drive it full speed in work and one man can handle it and bark 22 to 30 cords of 4 foot wood per day according to average size of wood.

Wood is fed end on and any size from 3 to 24 inches, as the wood runs without loss of time between sticks. No long shavings and greatest economy in wood. Machines may be seen working any time. Write me for particulars.

R. S. P. SMYTH - QUEBEC, QUE.

Sole Agent for Canada

*P. O. Box 236
L. D. Phone 386*

THE E. LONG MANUFACTURING CO., ORILLIA, ONT.

THESE SAW CARRIAGES ARE MADE OF CAST STEEL, AND OPEN 36 TO 54 IN. FROM SAW.

We build Double Edgers, Steam Feeds, Log Jacks, Live Rolls, Trimmers, Slab Slashers, Steam Niggers.

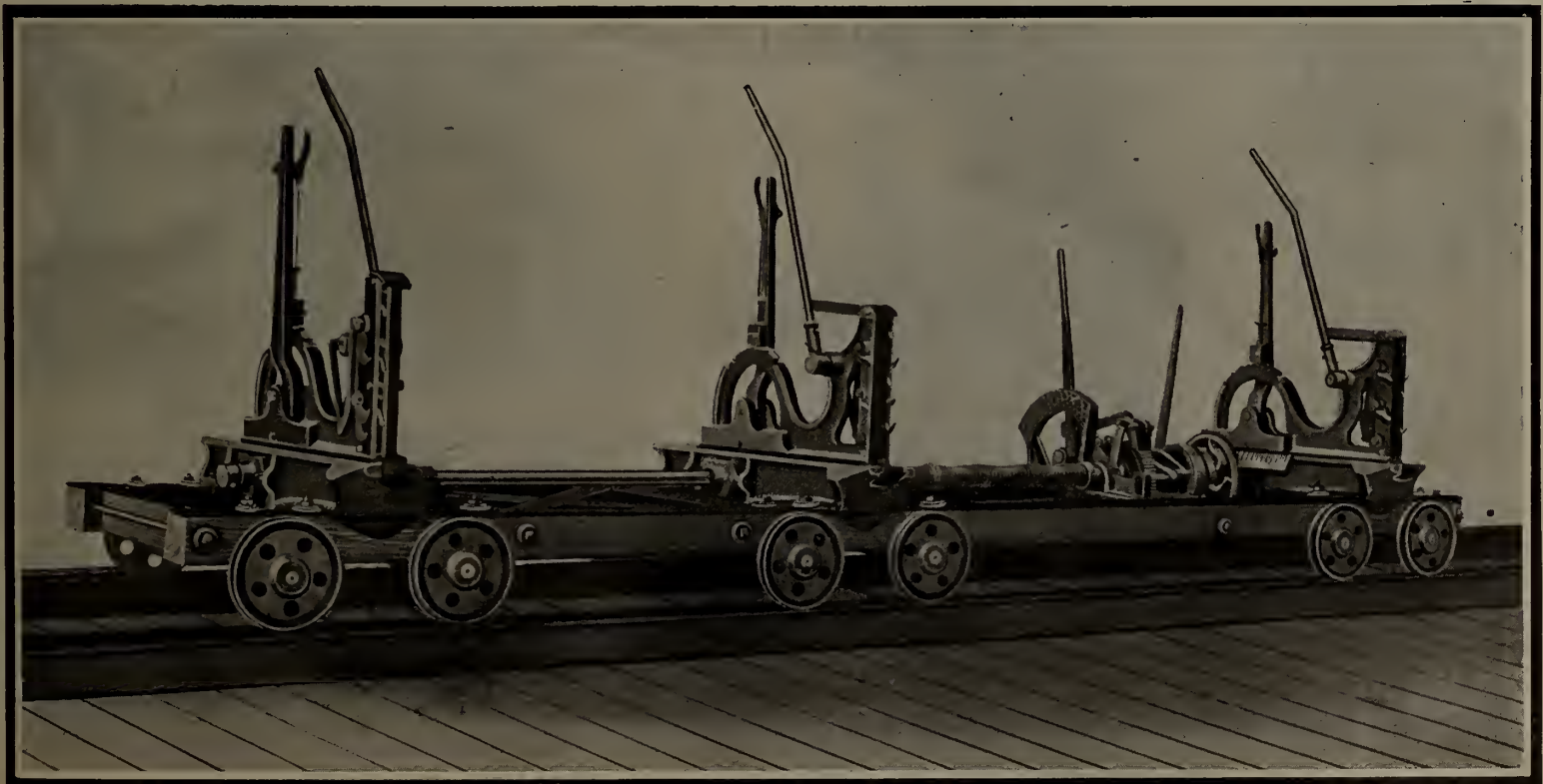

COMPLETE LINE OF SAW AND SHINGLE MILL MACHINERY
WRITE FOR CATALOGUE AND PRICES

"DEFIANCE"

Wood-Working Machinery

For Manufacturing

HUBS, SPOKES, WHEELS, WAGONS,
CARRIAGES, RIMS, SHAFTS, POLES,
NECK-YOKES, SINGLE TREES, BARREL
HOOPS.

Handles of Every Kind, insulated Pins, Spools,
Bobbins, Oval Wood Dishes, and General Wood-
Work.

Invented and Built by

THE DEFIANCE MACHINE WORKS,
Defiance, Ohio, U. S. A.

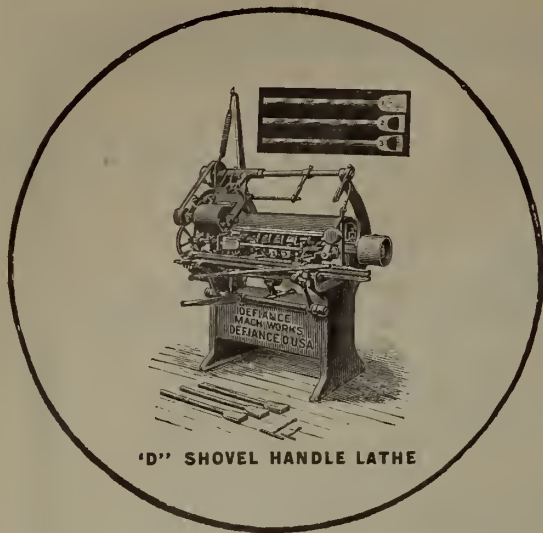

'D' SHOVEL HANDLE LATHE



OVAL WOOD DISH MACHINE

THE SCHAAKE MACHINE WORKS

NEW WESTMINSTER, B. C.

Builders of a Complete Equipment of

Saw^{and} Shingle Mill Machinery

SOLE MANUFACTURERS OF

Johnson's Improved Upright Shingle Machines

Pure Manila
Rope

HIGHEST QUALITY MADE

British Manila

Sisal Rope

PURE SISAL

Lath Yarn

Wire, Write or Phone

Canadian Cordage
& Manufacturing
Company, Limited

Toronto, Ontario, Canada

Long Distance Phone 162.

Our Rope and Lath Yarn are Recogniz-
ed as the Best on the Market.

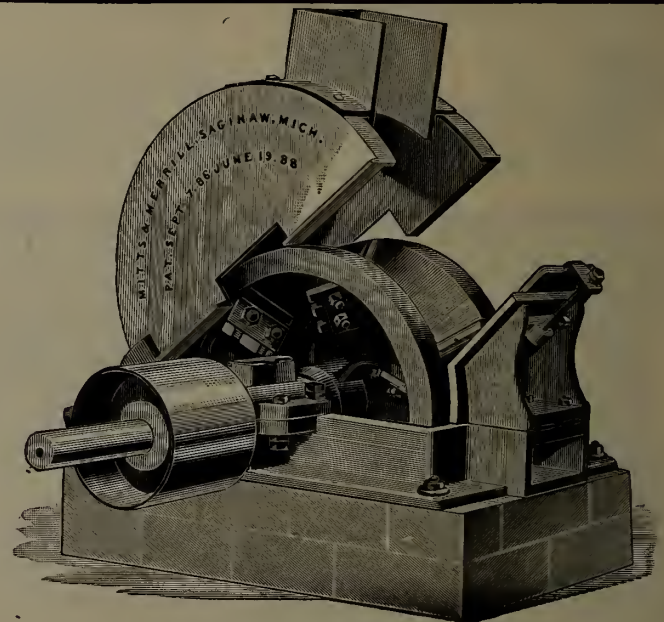

We Make "HOG" For Cutting

Slabs, Edgings and Blocks, Shingle, Sawdust and
Splints, Planing Mill and Box Factory Refuse,
Heading and Veneer Mill Waste, into fuel chips. Ex-
tract Chips into fine chips. Millions of dollars saved
by their use. Try One.

MITTS & MERRILL

807 Tilden Street, - - - Saginaw, Mich.

SEND FOR CIRCULAR E

R. H. SMITH CO., LIMITED

— St. Catharines, Ont. —

We are the Sole Manufacturers of Saws
under the

Simond's Process

in the Dominion of Canada.

There is no process its equal for tempering circular saws. Other makers recognize this fact, as some of them, in order to sell their goods, claim to have the same process. All such Claims are FALSE, as the patentee in the U. S. and ourselves are the only firms in the world who use it.



INSERTED TOOTH SAWS

Notice the improved shank. We call particular attention to the swell which strengthens it at the weakest part and which gives it more wear than the old style.

Shanks made in usual gauges and to fit your saws perfectly.

SHINGLE SAWS

The quality of the "Simonds" Shingle Saws is proven by the fact that the largest shingle and machine manufacturers in Canada are using them.

Run a "Simonds" and you will increase your output.



CROSS-CUT SAWS

THE "NARROW LEADER"

REFINED SILVER STEEL.

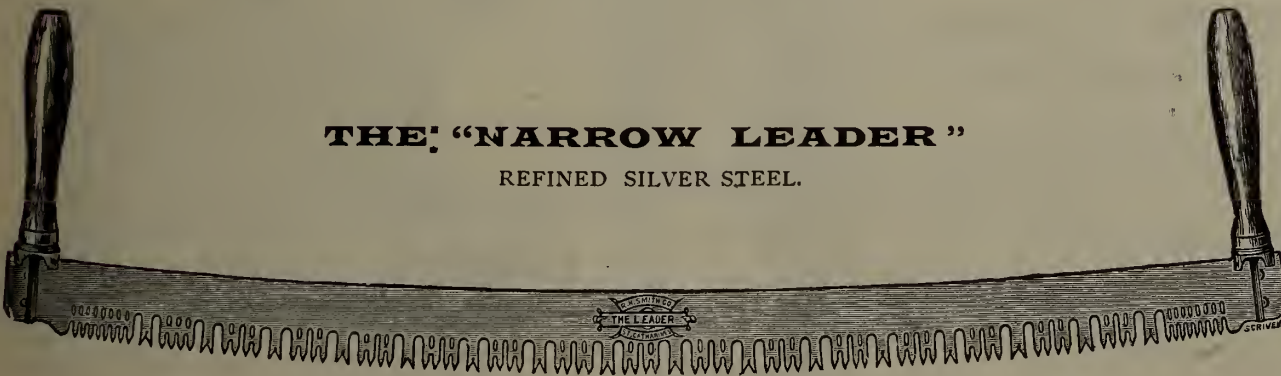

The Simond's temper and style of tooth make the "Leader" the fastest and easiest cutting saw manufactured.

Write for prices.

R. H. SMITH CO., Limited, St. Catharines, Ont.

CLASSIFIED INDEX OF ADVERTISERS

AXES

Dundas Axe Works..... 12

ALLIGATOR TUGS

West & Peachey..... 39

BELTING

Dominion Belting Co..... 37
Canadian Fairbanks Co..... 3
Gutta Percha & Rubber Mfg. Co..... 41
Goodhue & Co., J. L..... 1
McLaren, D. K..... 1
McLaren Belting Co., J. C..... 44
Sadler & Haworth..... 33
Waterous Engine Works Co..... 28
Wilby, P. H..... 12
Young, J. S..... 1

BUILDING BLOCKS

Cement Building Block Co..... 34

BABBITT METALS

Syracuse Smelting Works..... 28

BOILERS

Canada Foundry Co., Limited..... 12
Dymont Foundry Co..... 36
John McDougall Caledonian Iron Works..... 32

DOORS

New Century Refrigerator & Mfg. Co. 10

DRY KILNS

Andrews Co., The A. H..... 41
McEachren Heating & Ventilating Co. 43
Sheldon & Sheldon..... 43
Standard Dry Kiln Co..... 43

ELEVATING AND TRANSMITTING MACHINERY

Buhl Malleable Co..... 12
Dodge Manufacturing Co..... 11
Perrin & Co., R..... 37

EMERY WHEELS

Hart Corundum Wheel Co., Limited.. 26

ENGINES AND LOCOMOTIVES

Dymont Foundry Co..... 36
Gartshore, John J..... 10
Owen Sound Iron Works..... 41
Robb Engineering Co..... 35

EDGERS

Gordon Hollow Blast Grate Co..... 39

GRATES

Gordon Hollow Blast Grate Co..... 39

LUMBERMEN'S SUPPLIES

Beal Leather Co., R. M..... 28
Capstan Mfg. Co..... 22
Johnson, A. H..... 37
Montreal Tent, Awning & Tarpaulin Co..... 34
Merchants Rubber Company..... 34
Park, Blackwell Co..... 34
Rice Lewis & Sons, Limited..... 44
Thompson Mfg. Co..... 1
Woods, Limited..... 1

LUMBER AND SHINGLE MANUFACTURERS

Big Bend Lumber Co..... 6
B. C. Mills, Timber & Trading Co... 5
Cook & Bro. Lumber Co..... 34
Canadian Pacific Lumber Co..... 4
Cloverdale Milling Co..... 4
Crows Nest Pass Lumber Co..... 4
Columbia River Lumber Co..... 4
Delta Saw Mill Co..... 6
East Kootenay Lumber Co..... 6
Fernie Lumber Co..... 4
Hadden, D. & J..... 5
King Lumber Mills..... 4
Ladysmith Lumber Co..... 5
Moyie Lumber & Milling Co..... 4
North Star Lumber Co..... 6
Pigeon River Lumber Co..... 5
Sayward, J. A..... 5
Victoria Lumber & Mfg. Co..... 6
Yale-Columbia Lumber Co..... 4

LUMBERMEN'S TOOLS

Baldwin, Tuthill & Bolton..... 41
Burton Saw Co., A. J..... 40
Hamilton Stamp and Stencil Works... 44
Hay Knife Co., Peter..... 6
Pink, Thomas..... 44

MISCELLANEOUS

Alexander Engraving Co..... 1
Bradstreets..... 10
Canadian Office & School Furniture Co. 10
Denton, Dunn & Boulton, Barristers. 34
Fielding, J. S., Consulting Engineer.. 1
Glenyards Fire Clay Co..... 35
Georgian Bay Engineering Works—Grinders..... 43
Huther Bros.—Dado Heads..... 44
Lumber Mutual Fire Insurance Co.... 31
McFarlane-Neill Mfg. Co.—Cant Dogs. 35
Spence & Co., R.—Files and Rasps.. 11

Toledo Fire Insurance Co..... 29
Vogel, C. H.—Pulp Mill Engineer... 23

OILS

Commercial Oil Co..... 34
Canadian Oil Co..... 22
Queen City Oil Co..... 11

PROVISIONS

Clark, Wm..... 31
Eckardt & Co., H.P..... 30

PORTABLE SAW MILLS

Drake, F. J..... 36
Owen Sound Iron Works..... 41

PLANERS AND MATCHERS

Clark & Demill..... 3

PULLEYS

Dodge Manufacturing Co..... 11

PACKING AND PIPE COVERING

Garlock Packing Co..... 12
Purvis Co., E. L..... 35

ROPE

Canadian Cordage Co..... 8
Consumers Cordage Co..... 31
Dominion Wire Rope Co..... 12
Greening Wire Co., B..... 1
Mussen & Co., W. H. C..... 1

RE-SAWS

Cowan & Co..... 27

SAW SWAGES

Hanchett Swage Works..... 27

SAW GAUGES

Specialty Mfg. Co..... 37

STEAM BOILERS

Canada Foundry Co..... 12
Owen Sound Iron Works..... 41

SAWS

Atkins & Co., E. C..... 35
Burton Saw Co., A. J..... 40
Burns Saw Co., E. R..... 1
Buckeye Saw Mfg. Co..... 34
Hoe & Co., R..... 40
Shurley & Dietrich..... 9

SAW MILL MACHINERY

Allis-Chalmers-Bullock..... 3
Bartlett & Co., A. F..... 37
Furniture City Tool Co..... 43
Gordon Hollow Blast Grate Co..... 39
Hamilton Mfg. Co., Wm..... 2
Jenckes Machine Co..... 32
Long Mfg. Co..... 7
Lloyd Mfg. Co..... 39
Mershon & Co., W. B..... 39
Mowry & Sons, B. R..... 37
Owen Sound Iron Works..... 41
Petrie, H. W..... 44
Payette & Co., P..... 31
Schaaque Machine Works..... 8
Smart-Turner Machine Co..... 44
Waterous Engine Works Co..... 42
Williams, Madison..... 11

SHINGLE MILL MACHINERY

Drake, F. J..... 36
Long Mfg. Co., E..... 7
Owen Sound Iron Works Co..... 41
Schaaque Machine Works..... 8
Williams, Madison..... 11

TURBINES

Williams, Madison..... 11

TRIMMERS

Gordon Hollow Blast Grate Co..... 39

WOODWORKING MACHINERY

American Woodworking Machinery Co..... 38
Clark & Demill..... 3
Connell & Dengler Machine Co..... 6
Cowan & Co., Limited..... 37
Dodge Manufacturing Co..... 10
Defiance Machine Works..... 8
Mitts & Merrill..... 8
Perkins & Co..... 39
Rogers Iron Mfg. Co..... 40
Sherman Co., W. S..... 37
Shimer & Sons, Samuel J..... 40
Waterous Engine Works Co..... 42

The ... QUEEN CITY OIL CO. LIMITED

Head Office: TORONTO.

HIGHEST GRADES OF

Refined Oils Lubrication Oils

AND ALL

Petroleum Products

Advertisement for Canadian Office & School Furniture Co. Limited, featuring images of office and school furniture and a 'SEND FOR CATALOGUE' call to action.

ESTABLISHED 1849. BRADSTREET'S

Capital and Surplus, \$1,500,000. Offices Throughout the Civilized World.

Executive Offices: Nos. 346 and 348 Broadway, New York City, U.S.A. THE BRADSTREET COMPANY gathers information that reflects the financial condition and the controlling circumstances of every seeker of mercantile credit.

Subscriptions are based on the service furnished, and are available only by reputable wholesale, jobbing and manufacturing concerns, and by responsible and worthy financial, judiciary and business corporations.

THE BRADSTREET COMPANY.

OFFICES IN CANADA: Halifax N.S. Hamilton, Ont. London Ont.; Montreal, Que.; Ottawa, Ont.; Quebec, Que.; St. John, N. B. Toronto, Ont. Vancouver, B.C.; Winnipeg, Man.

THOS. C. IRVING, Gen. Man. Western Canada, Toronto

RAILS For Logging, Tramways, Switches, Etc. New and Second-Hand. YARD LOCOMOTIVES John J. Gartshore 83 Front St. West, (Opposite Queen's Hotel), Toronto.

R. SPENCE & CO. Beech File Works. HAMILTON, ONT. FILE AND RASP MANUFACTURERS AND RE-GUTTERS A trial order solicited. Write for price list and terms. C. P. MOORE, PROPRIETOR.

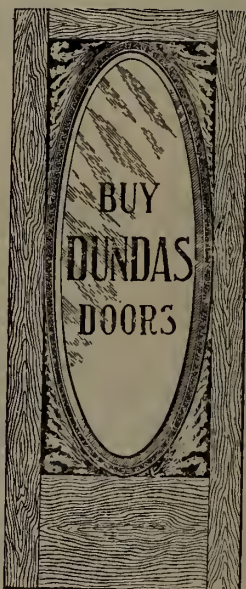

New Century Refrigerator & Manufacturing Co., Limited Dundas, Ont., Can.

Our Business is Manufacturing

HARDWOOD VENEER .. DOORS

With Built Up Bodies

These Doors are guaranteed not to warp or twist and are superior in construction and finish to any other Door on the market.

Send for Illustrated Catalogue and Prices.

Special attention given to Architects' Designs of Doors and Trims.

AGENTS WANTED EVERYWHERE. ADDRESS DOOR DEPARTMENT

Chain and Sprockets



We Carry an Immense Stock
for Quick Shipment!

DODGE MANUFACTURING CO.
TORONTO - MONRTEAL

THE TRIUMPH TURBINE

Is the most powerful wheel on the market to-day. A glance at this cut of the centre shows that the buckets are designed to secure the **maximum of speed** with **great power** and a **free discharge**. Mr. E. S. Edmondson, of Oshawa, writes as follows under date of November 16th, 1903, regarding a 26 inch Vertical Triumph Wheel:

"The Wheel is strictly first-class in every particular, and after a careful and thorough test I am prepared to say that I believe it is the best wheel in the market for Electrical purposes. It has high speed, large power, high efficiency at part gate, and has practically no leakage. I am more than pleased with the thorough and workmanlike setting you gave me throughout."

For horizontal settings in large Pulp Mills, Cement Mills or Electric Power Developments this Wheel has no equal. We invite your enquiries. Large catalogue to be had for the asking.

We are always glad to submit estimates and prices on **Improved Vulcan and Leffel Turbines, Improved Lane Circular Saw Mills, Edgers, Trimmers, Slashers, Shingle Machines, Lath Machines** and all machinery of this kind.

MADISON WILLIAMS

Successor to Paxton, Tate & Company
PORT PERRY, ONT.

Manitoba Iron Works
Western Selling Agents
Winnipeg, Man.

H. E. PLANT, Agent
Cor. Common and Nazareth Streets
Montreal, Que.



TEON BELTING



STAM PROOF
 WATER " "
 HEAT " "
 OIL " "
 ACID " "
 Stronger and Cheaper than
 Leather.

LEATHER BELTING CAMELS HAIR BELTING
 CAPATA BELTING [BALATA TYPE] LACE LEATHER, ETC.

Special Arrangements for Trial Belts.
 Write for Price Lists and Discounts.

P. H. WILBY, 27 1/2 Front Street East, TORONTO
 Phone Main 1930. SOLE AGENT FOR CANADA.

Dundas Lumberman



*A New Axe tempered by a new process which enables us to submit to any lumberman three or more samples of Axes, all different degrees of hardness, and on a selection being made we will guarantee to furnish any number all exactly the same temper as sample chosen.

THE DUNDAS AXE WORKS
 Dundas, Ont.

LARGE STOCK CARRIED & CUT TO ANY LENGTH
 BLOCKS, CLIPS, TURNBUCKLES, ETC.

WIRE ROPE

SPECIAL ROPES FOR LUMBERING
 DOMINION WIRE ROPE Co., LTD
 MONTREAL, QUE.

EVERY LUMBERMAN WANTS IT

35 cents buys it

Scribner's Lumber and Log Book

BRIMFUL OF EVERY-DAY PRACTICAL INFORMATION

Address: THE CANADA LUMBERMAN, Toronto

STEAM BOILERS



Portable Boilers—Locomotive Style
 Return Tube Tubular
 Tanks, Water Towers, Smoke Stacks, etc.

CANADA FOUNDRY COMPANY, LIMITED

Head Office and Works: TORONTO, ONT.

District Offices: Montreal Halifax Ottawa Winnipeg Vancouver Rossland Calgary

ENGINEERS

FOUNDERS

MACHINISTS

BUHL MALLEABLE
 COMPANY,
 DETROIT, MICH.

Elevating, Conveying and Power
 Transmitting Machinery

SPROCKET CHAIN AND WHEELS

MALLEABLE OR STEEL BUCKETS

We Guarantee our Goods to be of Standard Design and Unexcelled Quality.

Belt Conveyors and Spiral Steel Conveyors

The Fairbanks Company

MONTREAL TORONTO VANCOUVER WINNIPEG



Garlock Packing Co.

HAMILTON - - - CANADA

—SOLE MANUFACTURERS OF—



GARLOCK'S PACKINGS

PATENTED

Asbestos and Mineral Wool Pipe and Boiler
 Coverings, Engineers' Supplies in General

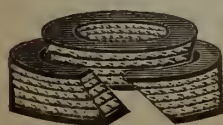

THE CANADA LUMBERMAN AND WOOD-WORKER

VOLUME XXV.
NUMBER 4.

TORONTO, MONTREAL, WINNIPEG, APRIL, 1905

TERMS, \$1.00 PER YEAR
Single Copies, 10 Cents

CANADIAN FORESTRY ASSOCIATION

Proceedings of the Sixth Annual Meeting at Quebec—Much Information Submitted About Forest Fires and the Forest Resources of Canada.—Next Convention to be Held in British Columbia.

The sixth annual convention of the Canadian Forestry Association was opened in the Council Chamber of the City Hall, Quebec, on Wednesday, March 10th, with Mr. Aubrey White, Assistant Commissioner of Crown Lands of Ontario, President of the Association, in the chair. There was a good attendance of members, including the following:

Wm. Little, Westmount, Montreal, honorary president; E. G. Joly de Lotbiniere, vice-president, Quebec; E. Stewart, Dominion Superintendent of Forestry, Ottawa; Dr. Judson F. Clark, Ontario Bureau of Forestry, Toronto; R. H. Campbell, Ottawa, secretary; Norman M. Ross, Ottawa, treasurer; Dr. C. A. Schenck, Biltmore, N. C.; Prof. Filibert Roth, University of Michigan, Ann Arbor, Mich.; E. J. Zavitz, Ontario Agricultural College, Guelph, Ont.; Dr. Robt. Bell, Director of the Geological Survey, Ottawa; Mgr. Laflamme, Laval University, Quebec; Hon. Hewitt Bostock, Montè Creek, B.C.; Jas. Leamy, Dominion Crown Timber Agent, New Westminster, B.C.; J. G. Jardine, Vancouver, B.C.; F. W. Jones, Columbia River Lumber Co., Golden, B.C.; G. C. Wilgress, Huntville, B.C.; Prof. Knetchel, Albany, N. Y.; W. H. T. Addison, Toronto; Gordon C. Edwards; Hon. Recorder Weir, Montreal; H. Wallin, Bureau of Forestry, Ottawa; Roland D. Craig, Bureau of Forestry, Ottawa; E. B. Biggar, Pulp and Paper Magazine, Toronto; G. H. Muir, CANADA LUMBERMAN, Toronto; T. G. Loggie, Fredericton, N.B.; A. E. Alexander, Campbellton, N.B.; H. M. Price, Quebec; W. C. J. Hall, Quebec; W. F. V. Atkinson, Quebec; J. T. Bertrand, Isle Verte; J. C. Langelier, Quebec; Rev. T. W. Fyles, Levis; Chevalier Baillairge, C.E., Quebec; M. M. Boyd, Bobcaygeon; Angus McLean, Buffalo; Mr. Rothwell, Berlin Falls; Hon. P. E. Leblanc, W. G. Power, S. P. Grogan, J. Champoux, David Gillies, M.P., Henry O'Sullivan, Hiram A. Calvin, M.P., J. W. Hamilton, F. M. Dugan, Wm. Van Felson, J. Obalski, W. K. Trower, Hon. R. Turner, Mr. Savard, Mr. L. Henreux and others.

After the minutes of the last convention had been adopted, the Secretary submitted the annual report of the Directors, which was, in part, as follows:

Report of Directors.

The report of the last annual meeting was published at the Government Printing Bureau through the kindness and at the expense of the Forestry Branch of the Department of the Interior. This report has been distributed as usual to the members of the Association, members of the legislative bodies throughout the Dominion, the Press and others. The Annual Report places the proceedings and deliberations in a permanent form and makes them available for reference and study. The report for the past year is well up to the character



MR. E. G. JOLY DE LOTBINIERE,
President-Elect of the Canadian Forestry Association.

of previous reports, both in material and illustrations, and the thanks of the Association are due to the Dominion Superintendent of Forestry for so kindly arranging to carry what would have otherwise been a necessary but heavy expense to the Association.

During the year the Association has lost some of its most active members by death. Mr. John Bertram, a member of the Board and one of the strongest supporters of the Association, passed away after a lingering illness. He took a large and helpful part in the proceedings of the last annual meeting and the papers he has presented to the Association at different meetings have had a strong influence in the formation of public opinion on forestry and the shaping of the forest policy of Canada. As a member of the Ontario Forest Commission he did good service to his own province, and he had been called to exercise his talents in a wider sphere as Chairman of the Dominion Transportation Commission. His loss will be felt through a wide circle both in public life and among his more intimate friends. Dr. W. H. Muldrew, who was also present at the last annual meeting, died suddenly in October after only a few days' illness. As Dean of the MacDonald Institute at Guelph he was beginning the development of

work in Nature Study that promised much for the future interest of the children in the trees and natural objects. Mr. W. C. Caldwell, M.P.P., of Lanark, and Colonel Thos. Higginson, Vankleek Hill, both leading lumbermen and members of the Association, have also died during the year.

We are sure that all the members of the Association will sympathize fully with our honored First President, His Honor Sir Henri Joly de Lotbiniere, and with our Vice-President, Mr. E. G. Joly Lotbiniere, in the loss they have sustained in the past year by the death of Lady Joly Lotbiniere. The Board have conveyed an expression of their sympathy to the bereaved relatives.

MEMBERSHIP.

The Secretary has made a special effort during the year to increase the membership of the Association by the sending out of copies of the Annual Report and invitation to membership in the Association to persons whose names were submitted by members. The result has been fairly satisfactory and has resulted in a considerable increase in membership. This has been somewhat discounted by a falling off in Manitoba and the North-west Territories. Following is a comparative statement of the membership for the past two years:—

	1904.	1905.
Nova Scotia.....	14	21
New Brunswick.....	14	22
Prince Edward Island.....	1	3
Quebec.....	98	113
Ontario.....	134	187
Manitoba.....	80	72
Assiniboia.....	23	22
Saskatchewan.....	3	4
Alberta.....	60	42
British Columbia.....	25	32
Newfoundland.....		1
U.S. America.....	24	32
England.....	2	5
Ireland.....		1
India.....		1
Honolulu.....		1
Germany.....	1	1
Denmark.....		1
Austria.....		1

Life Members	479	562
	33	39

The receipts for last year were \$1,845.77 and the expenditure \$930.66, leaving a balance on December 31st last of \$915.11. The amount now standing to the credit of the Association is \$989.75, but against this is the account for the Forestry Journal for January amounting to \$150 and the expenses of this meeting, about \$100. The thanks of the Association are again due to the Governments of the Provinces of Ontario, Quebec and British Columbia for the grants given by them to the work of the Association.

OFFICIAL ORGAN.

In accordance with the instructions of the last annual meeting, your Board took steps to arrange for the publication of an official organ to be devoted to the interests of the Association and the advancement of the forestry movement generally. Dr. Wm. Saunders, Professor John Macoun and Mr. E. Stewart were appointed provisionally as an Editorial Committee and Mr. R. H. Campbell as Editor and Business Manager. The first number of the Canadian Forestry Journal, the name decided on for the paper, was issued in January and has been distributed to the members of the Association. The intention is to issue quarterly for the present, with the hope that the future may lead to a development that will permit of a more frequent appearance of the journal. The Board would like to impress on the members of the Association the necessity for their rendering every assistance to the editorial

management to make the magazine thoroughly representative and generally useful. The whole question of the official organ is submitted for the consideration of the Association, and it is desirable to have a full expression of opinion upon it.

FOREST FIRES.

The resolution passed at the last Annual Meeting recommending the prohibition of fires for clearing in the Province of Quebec except from the 15th June to the 31st August was transmitted to the Government of that Province, and that urging protection of the watersheds was sent to the different Governments throughout the Dominion.

The resolution relating to the prevention of fires along lines of railway and especially in the construction of the new trans-continental road was transmitted to the Dominion Government and to the representatives of the railway companies. Replies were received from the Department of Railways and Canals, and from the general manager of the Grand Trunk Pacific Railway Company, stating that the question would be given careful consideration and steps taken in the direction indicated by the resolution. As this is a question of the utmost importance and urgency, the Association may very well re-affirm its attitude thereon.

Forest fires are still causing destruction in Canada, although their extent has been largely controlled by the fire ranging system now generally adopted throughout the Dominion. British Columbia has, outside of the Railway Belt which is protected by Dominion fire rangers, suffered the most severely, as the season was dry throughout, and that province has unfortunately, in spite of its great forest wealth, not provided for a fire ranging force such as has proved effective in other parts of Canada. In Nova Scotia, the fire warden service established under the act passed at the last session of the Legislature, has proved successful in the counties in which the system was inaugurated. The report of the Crown Lands Department shows that numerous fires were prevented or extinguished in their incipiency and the loss in many counties, large in previous years, has been reduced to a minimum.

Under Dominion jurisdiction, there were forty fire rangers employed and the result was that there was little destruction by forest fires except in the Crow's Nest Pass, where there was great difficulty in controlling them. The success in the railway belt in British Columbia in preventing loss was most marked, and to show how the cost of a fire ranging service is saved over and over again in the value of timber protected, it will be permissible to quote from a letter received by the Dominion Forestry Branch from the Columbia River Lumber Company as follows:

"We feel satisfied that without the fire ranging system and the extra work which was done in the last six weeks, practically all the timber tributary to Shuswap Lake would have been destroyed and, as you know, this amounts to a good many hundred of millions of feet."

TREE PLANTING.

The tree planting scheme under Federal management in Manitoba and the North-West Territories continues to develop. During the year 1904, 1,800,000 trees were distributed to 1027 settlers, an average to each of 1752 trees. In 1905 the distribution will be 2,000,000 trees to 1120 settlers. The Forestry Branch has so far sent out about 5,000,000 trees and 2,000 lbs. of tree seed. Educational work in this connection is being done by addresses at the meetings of Farmers' Institutes, and a forestry exhibit was shown at the Dominion Exhibition at Winnipeg.

In Ontario a beginning has been made in the setting out of a nursery at the Ontario Agricultural College at Guelph from which the farmers of that province may obtain supplies of forest trees for planting. Lectures on forestry at Farmers' Institutes and gatherings of a similar nature will be given to explain the plans of the Government and furnish general information on the management of trees.

In the first week of January of the present year, a Forest Congress was held at Washington, which was attended by a number of Canadian representatives. The Congress brought together some four hundred people, representing not only scientific foresters and the forest enthusiasts, but practical and leading men in

lumber industry, in railroad management, in mining in irrigation and manufactures, men whom the practical necessities of the case had forced to take an interest in forestry and who showed by their presence and active interest that forestry is no longer a fad but a business question of supreme national importance. The effect of this meeting on the public of the United States should be far-reaching, and it is a question worthy of consideration as to whether the time has not arrived to make a special effort of a similar nature in Canada.

A committee representing your Board waited upon His Excellency, Earl Grey, recently to ask him to be kind enough to act as Patron of the Canadian Forestry Association. His Excellency received the committee most graciously and was pleased not only to consent to give his patronage, but far exceeded their expectations by stating that he would be pleased to do anything further in his power to assist the work of the Association and suggested that, in the event of an evening meeting being held in Ottawa during the present season, he would be pleased to attend and might arrange to have it held at Government House. This kindly action of His Excellency and the evidences of his sympathy with movements affecting the well-being of the Dominion should give him a high place in the respect and affection of Canadians and especially of the members of the Forestry Association.



MR. W. C. J. HALL,
An Active Member of the Local Committee.

The thanks of the Forestry Association are due to the press for their interest in its work, and the notice given it in their columns from time to time, to the railway companies who have again kindly granted single fare for the annual meeting, and to kindred societies from whom assistance has been received in various ways.

President's Address.

Following the report of the Directors the President gave a brief address *extempore*. He had first to congratulate himself on being President of the Association in a year when its meeting was held in the Ancient Capital of Canada. Here was the nursery of all the developments that have taken place in every direction throughout the Dominion. Under the French regime the first Crown timber regulations were promulgated, and some of the problems which confronted the framers of the early laws have come down to the present day. The rights of the settlers and kindred matters are just as live questions to-day as they were two or three hundred years ago. Mr. White spoke of the forestry movement, and said that the first impetus to the organization had been given at a meeting held in Montreal in 1882. The good seed sown then had its results later. In 1890 the American Association held its meeting in Quebec, and as the present Governor-General, Earl Grey, had expressed his deepest sympathy with the movement, so did the Governor-General of that day, Lord Stanley, who

had been greatly interested. The first steps taken towards the organization of the Canadian Association was taken, thanks to the work of Mr. Stewart, who is present here to-day, in 1890. From that time slow, but steady progress has been made. Canada possessed unbounded forestry resources, and the Association desired to impress upon the Government the taking of steps to protect and conserve those resources. One particular point was to prevent loss by forest fires, and the fire ranging system advocated by the Association, and first established in a small way in the Province of Ontario, has now been followed by every Province in Canada. Another desire was to preserve the watersheds of the great rivers, and also to protect the denizens of the forest. One of the most difficult questions was to keep out settlers from land unfitted for settlement, but which contained valuable timber. Since all varieties of timber have taken on such value the settler is anxious to go in, not for the agricultural possibilities, but that he may cut and dispose of the timber on the land. That was one of the greatest problems with which he had to contend with in Ontario, and some systematic effort should be made to draw the line, and to say that where land is unfit for settlement no settler shall be allowed to go in. He hoped that the Association would draw up a resolution on the subject. The Association's desire was to create a public sentiment in favor of forest preservation and protection. The idea that the Association was a collection of faddists, whose theories were impracticable, had now been dispelled and many leading people are now coming in to help the movement.

The President said the membership of the Association should be much larger than it was, and instead of 575 members it should be 5,000, and if the members would only exert themselves the number would be greatly increased.

At the morning session a paper by Prof. R. W. Brock, of Queen's University, Kingston, was read by Mr. Roland D. Craig, of the Bureau of Forestry, Ottawa, the title being "Forest Fires in British Columbia." This was followed by an address on "Forest Protection on Dominion Lands in British Columbia," by Mr. James Leamy, Dominion Crown Timber Agent, New Westminster, B. C. Mr. Leamy emphasized the necessity of greater fire protection in British Columbia, and stated that many prospectors set fire to the woods in order to secure a place for prospecting. The fire rangers followed the prospectors and extinguished the fires. He hoped the system would be greatly extended in the near future.

Mr. E. Stewart told of the regulations adopted for protecting the timber within the Railway Belt in British Columbia, and was followed by Hon. H. Bostock, Mr. F. W. Jones, and others.

Dr. C. A. Schenck, of Biltmore, North Carolina, who has charge of the Vanderbilt lands, was called upon, and gave an interesting address. He compared business forestry with what he termed landscape forestry and urged that unless we had forestry on business principle, we could never have it on a large scale. He was glad to see that in Canada the business men realized the importance and the value of

the question. He spoke of the importance of Governments designating just what land is actual forest land and what is land for agriculture. All soil that is absolutely forest soil should be reserved. Government ownership was best for this. If large tracts are required let the Government own them. All absolutely forest land should be reserved by the Government.

Prof. Filibert Roth, University of Michigan, Ann Arbor, Mich., followed Dr. Schenck and endorsed that gentleman's views. He said State forestry was much superior to private forestry.

AFTERNOON SESSION.

At the afternoon session the following committee on resolutions was appointed to deal with certain questions arising out of the report of the directors:—Messrs. E. Stewart, F. W. Jones, R. H. Campbell, E. G. Joly de Lotbiniere, T. G. Loggie, H. M. Price, Aubrey White.

A telegram was read from Mr. J. R. Booth, of Ottawa, as follows: "Have carefully read your report, which I find very interesting; sorry I cannot attend." A telegram was also read from Hon. W. C. Edwards, M. P., Ottawa, regretting his absence, and advising the Association that Sir Wilfrid Laurier, who has always taken a lively interest in the work of the Association, had expressed a desire to have a large Forestry conference called to meet at Ottawa during the coming summer or in the autumn.

The first paper read was by Rev. T. W. Fyles, of Levis, on "Forest Insects". Mr. T. G. Loggie, of the Crown Lands Department, Fredericton, presented a paper on "The Forests of New Brunswick", which will be found in this issue.

In the absence of Hon. J. W. Longley, Commissioner of Crown Lands for Nova Scotia, who was to have contributed a paper, Dr. Robt. Bell, Director of the Geological Survey of Canada, was called upon. He spoke briefly of the northern forests of the Dominion, touching upon the distribution of trees, and instancing the vast number of species to be found. He cited the fact that in the United States and Canada combined, there were a total of 340 species of forest trees, while in the whole of Europe there were only 30. Dr. Bell gave many interesting facts in connection with his subject and many instructive circumstances were related, in regard to forest fires in the north.

THE BANQUET.

On Thursday evening the friends of the Forestry Association in the City of Quebec tendered a banquet to the President and visiting members. Especial arrangements had been made at the Chateau Frontenac and the event was a sumptuous affair. About one hundred persons were seated around the festive board, which was formed in the shape of a horseshoe. By request, President White presided. When "The King" had been duly honored, the Chairman proposed the toast of "The Dominion Forestry Bureau," to which Mr. E. Stewart responded. Senator Bostock, of British Columbia, first responded to "Pro-

vincial Forestry Departments," and was followed by Dr. Clark, of the Ontario Forestry Department, Mr. T. G. Loggie, of the Crown Lands Department of New Brunswick, and Mr. W. C. J. Hall, of the Quebec Crown Lands Department. To the toast of "Our Educational Institutions," Prof. Roth, Rev. T. W. Fyles, and Mr. E. G. Joly de Lotbiniere replied. The President closed the banquet with a very brief but interesting address.

SECOND DAY.

At 10 o'clock on Friday morning the convention resumed, when the Secretary read Hon. Mr. Longley's paper on "The Fire Warden Service of Nova Scotia". A very valuable and lengthy paper was then submitted by Mr. J. C. Langelier, entitled "The Forest Wealth of the Province of Quebec". The area of the forests of the Province, their divisions, their value, their products were all touched upon in clear and concise terms, and the immense capital which they represented was placed before the Association with a wealth of carefully prepared statistics. A very interesting description of the varieties of woods to be found in the Province was given. For the purpose of classifying them according to the prevailing growths, Mr. Langelier divided the forests of the province into three distinct regions, the Northern, the Central, and the Southern. His estimates of the quantity of timber available in each district were as follows:

NORTHERN REGION OF QUEBEC.

SAW LOGS :	
Pine, white and red.....	325,000,000 ft. B.M.
Banksian pine.....	10,000,000,000 " "
Spruce.....	35,000,000,000 " "
Poplar.....	10,000,000,000 " "
White birch (bouleau)....	10,000,000,000 " "
	65,325,000,000 ft. B.M.

PULP WOOD :	
Black spruce.....	406,874,470 cords.
White spruce.....	15,000,000 " "
Fir.....	101,118,607 " "
Poplar.....	100,000,000 " "
	622,993,077 cords.

RAILWAY TIES :	
Banksian pine.....	320,000,000 pieces.
Cedar.....	50,000,000 " "
	370,000,000 pieces.

CENTRAL REGION OF QUEBEC.

SOFT WOODS—SAW LOGS :	
White Pine.....	30,025,000,000 ft. B.M.
Red pine.....	7,500,000,000 " "
White spruce.....	60,000,000,000 " "
Hemlock.....	200,000,000 " "
	98,025,000,000 ft. B.M.

HARD WOODS :	
Birch, yellow and black...	300,000,000 ft. B.M.
Maple.....	300,000,000 " "
Oak.....	10,000,000 " "
Elm.....	200,000,000 " "
Ash.....	125,000,000 " "
Birch.....	15,000,000 " "
Butternut.....	5,000,000 " "
Basswood.....	100,000,000 " "
White birch (bouleau)....	150,000,000 " "
Poplar.....	250,000,000 " "
	1,415,000,000 ft. B.M.

PULP WOOD :	
White spruce (from tops)..	15,000,000 cords.
Black spruce.....	20,000,000 " "
Fir.....	2,500,000 " "
Poplar.....	50,000,000 " "
	87,500,000 cords.

RAILWAY TIES :	
Banksian pine..	150,000,000 pieces.
Cedar.....	60,000,000 " "
Birch.....	15,000,000 " "
	225,000,000 pieces.

POLES FOR ELECTRIC WIRES :	
Cedar.....	10,000,000 pieces.
SHINGLES :	
Bolts from hollow butts...	3,000,000,000 shingles.
CULVERT TIMBER :	
Cedar.....	5,000,000 cub. ft.
SOUTHERN REGION OF QUEBEC.	
SOFT WOODS—SAW LOGS :	
White pine.....	75,000,000 ft. B.M.
White spruce.....	12,000,000,000 " "
	12,075,000,000 ft. B.M.

HARD WOODS :	
Birch, yellow and black...	100,000,000 ft. B.M.
Maple.....	50,000,000 " "
Elm.....	20,000,000 " "
Ash.....	5,000,000 " "
Birch.....	10,000,000 " "
White birch (bouleau)....	25,000,000 " "
Poplar.....	15,000,000 " "
	225,000,000 ft. B.M.

The President highly complimented Mr. Langelier upon his able paper, which was followed by an interesting discussion.

Mr. Wm. Little, of Montreal, then read a short paper comparing the very small losses by forest fires in European countries as contrasted with the gigantic losses sustained in America, and which was due to the superior and efficient methods of fire protection in vogue.

RESOLUTIONS.

The report of the committee on resolutions was then presented, and the following resolutions were adopted:

1. That the Secretary is hereby authorized to convey to the relatives of deceased members an expression of the deep sympathy of the Association.

2. That the Association has learned with great pleasure through a telegram from Senator Edwards that the Right Hon. the Premier of Canada has expressed his desire that a Forestry convention be held during the coming summer or autumn in Ottawa, and that the Dominion Government will render suitable aid to such a convention. The Association desires to express its great gratification at the interest in its work indicated by this action on the part of the Premier of the Dominion and to express its hearty concurrence in the suggestion for holding such a Forestry convention, and therefore the Executive Committee of the Association is hereby authorized to confer with the Right Hon. the Premier and to take such steps as may be necessary to carry out the proposed convention.

3. That this Association re-affirm its previous resolution in regard to the proposed construction of the new trans-continental railway and the danger of serious loss of valuable timber consequent if all possible precautions are not taken to prevent starting of fires.

4. That the Association begs to respectfully call the attention of the British Columbia Government to the necessity of establishing a system of fire ranging for the preservation of the forest areas in British Columbia wherever railway lines or settlement extend. The experience of Ontario and the other Eastern Provinces and in the Dominion railway belt in British Columbia indicate clearly the benefits to be derived from an efficient fire ranging system as a magnificent return on the comparatively small expense; and further that an arrangement should be made between the Government and railways operating in British Columbia for joint co-operation in guarding against forest

fires along their lines, and that said railways should be required to clear their right of way of all inflammable material.

5. That in view of the difficulty in dealing with cases of fire started for the clearing of land and for other purposes, the Canadian Forestry Association beg to respectfully submit to the Government of British Columbia that the Bush Fire Act of that Province should be amended so as to prohibit the starting of fires except for cooking or for other necessary purposes between the first of May and the first of November in each year, unless a special permit for the purpose be granted by the Forest Ranger or other officer appointed for the district in which such permission is asked; and that the permits for the clearing of land by fire shall only be issued after inspection of the locality by said forestry ranger or other officer, and that any forest fire ranger appointed by either the Dominion or Provincial Government shall be clothed with the authority of a constable in connection with all offences under said Bush Fires Act.

6. A similar resolution to the above was passed in connection with New Brunswick, changing the dates to the 1st of May to 1st December and the name of the act to the New Brunswick Fire Act of 1888.

7. That the action of the General and Provincial Governments be heartily commended for extending the respective forest reserves of the country, and further that this Association urge upon such Governments the advisability in the country's interest of still further extending this policy of reserves.

Hon. Senator Bostock extended an invitation to the Association to hold its next convention in British Columbia. It was decided, however, to leave the matter in the hands of the Board of Directors with the understanding that if possible the meeting be held in British Columbia.

ELECTION OF OFFICERS.

The election resulted as follows:

Patron—His Excellency the Earl of Grey.

Hon. President—Aubrey White, Toronto.

President—E. G. Joly de Lotbiniere, Quebec.

Vice-President—E. Stewart, Ottawa.

Secretary-Treasurer—R. H. Campbell, Ottawa.

Board of Directors—T. Southworth, Toronto; Wm. Saunders, Ottawa; Dr. Bell, Ottawa; J. R. Booth, Ottawa; Hiram Robinson, Ottawa; H. M. Price, Quebec; Mgr. Laflamme, Quebec.

Vice-Presidents for the Provinces—Rev. A. E. Burke, Alberton, P.E.I.; Hon. J. W. Longley, Halifax, N.S.; His Honour J. B. Snowball, Chatham, N.B.; Hon. S. N. Parent, Quebec; Hon. J. N. Agnew, Winnipeg, Man.; Hon. H. Bostock, Monte Creek, B.C.; Wm. Pearce, Calgary, N.W.T.; His Honour A. E. Forget, Regina, Assa.; F. D. Wilson, Fort Vermilion, Atha.; Lieut. Governor of Manitoba, Keewatin.

Friday afternoon the members were taken by special cars over the Quebec Railway, Light and Power Company's line to Montmorency, where a pleasant time was spent. In the evening a public meeting was held at the

Morrin College Hall, when Dr. Judson F. Clark, Forester for the Ontario Government, gave an illustrated address on "The Forest as a Natural Resource," and Mr. W. H. F. Addison, of the Yale Forest School, spoke on "A Forest School." Both addresses were very interesting and much appreciated.

The convention adjourned Friday evening *sine die*.

AGITATION FOR REPEAL OF THE PIKE LAW.

A bill has been introduced in the Maine Legislature for the repeal of the Pike law which permits American citizens to cut timber in the United States, transport it to the province of New Brunswick for manufacture and take it back free of duty.

"The St. John Lumber Company, which has a mill at Van Buren (Me.), on the upper St. John, wants the law repealed," said a St. John lumberman when interviewed, "and they are doing it in a spirit of spite. Millmen at the mouth of the river do not want piers in the river at Van Buren, the company named does, and because local men are agitating against the piers the company seeks the repeal of the Pike law.

"If repealed," he continued, "the St. John Lumber Company would have practically control of the cut in Maine on the upper St. John. At present much of it comes to St. John and is manufactured in the American-owned mills here. The repeal of the law would affect the latter, but not the Canadian mills here, which saw only New Brunswick lumber.

"At present the owners of timber lands in Maine along the river lease their timber to millmen at a stumpage rate. If the law is repealed, the effect would be that the American millmen here would be out of the competition for this timber and naturally the St. John Lumber Company would be the only market for the land owners and the company could cut the land owners' stumpage rate practically as they wished. So the land owners are stoutly opposed to the law being repealed and they are an influential body."

At last year's session of the New Brunswick legislature there came up a proposition to put into operation an export duty on logs cut on New Brunswick crown lands and taken to Maine to be sawn. It did not become law, however. If the Pike law is repealed New Brunswick lumbermen may agitate to have this export duty put on.

Files often need renovating, particularly in heavy work. To do this clean first from all dirt, then dip in a solution of one part of nitric acid, 3 parts of sulphuric acid and 7 parts of water. The time to leave the file immersed depends on the extent to which it has been blunted; say, roughly, from a few seconds to about five minutes. Wash the file in water when taken out of the solution. Now dip it in milk of lime. Having washed off the lime, dry gently. Finally rub with a mixture in equal part of turpentine and olive oil. It is well afterwards to brush over with some finely-powdered coke.

NEW BRUNSWICK'S FORESTS.

By T. G. LOGGIE.

From its earliest history, the products of the forests of New Brunswick have held a first place in trade exports. Although a large section of the province is admirably suited for agriculture, particularly the magnificent intervals of the River Saint John, stretching almost from its mouth upwards to the limits of the province, a distance of 300 miles of the Miramichi, Kennebecasis and other valleys and the broad salt marshes of the Upper Bay of Fundy, still lumber has remained King.

New Brunswick contains an area of $17\frac{3}{4}$ millions of acres; of this acreage $10\frac{1}{2}$ millions are granted and $7\frac{1}{4}$ Crown lands, and the province is everywhere drained by large rivers, with innumerable branches, almost locking each other at their source.

It will thus be seen that lumbering can be carried on advantageously, as one has yet to find a section of the province where logs cannot be cut and driven down these waterways to market. Of those rivers, the Saint John is the largest and drains nearly one half of the province. Next in importance is the Miramichi, its watershed embracing about 5,000 square miles.

The settled portions of the province are principally along the river valleys and coastline, the interior forming one vast timber preserve and embracing a territory 80 miles wide and 100 miles long, without habitation of any kind save the lumberman's or trapper's shanty and no sound except the ring of the woodman's axe or the call of the hunter. Here is a domain fairly free from the ravages of fire and timbered with all kinds of valuable lumber. The greater part of this territory is unfit for cultivation, lying on the granite and boulder formation, although the northern section, in its approach to the Restigouche River runs into the Upper Silurian belt, and consequently has good deep soils. Everywhere over this belt, both black and white spruce abounds, some pine and vast quantities of the hardwoods that have scarcely been touched, also large quantities of the finest and largest cedar in Eastern Canada.

Leaving this section of the province, and turning our attention to the country lying southerly and south-westerly of the South-West Miramichi, and extending to the Bay of Fundy, we find a territory heavily cut and in places badly burned. The Nashwaak River is an exception, where Alexander Gibson, our Lumber King, still reigns supreme.

In reading reports from time to time of the timber domain of Canada, as well as of the United States, the same story is read and re-read of devastation by forest fires. New Brunswick has not escaped. The great Miramichi fire, that swept through this province in the year 1825, is a matter of history. Scarcely a year elapses without more or less fires, although of late we have suffered less, perhaps, than our neighbors.

Our Legislature and lumbermen have grappled for years with this great question, and the Government has still under consideration more effectual methods in checking the ravages of forest fires. In the year 1885 the Legislature passed the Act now in force. It contains provisions prohibiting fires from being set between the first day of May and 1st December, except in clearing land, obtaining warmth or necessary industrial purposes, and then precautionary measures to be taken. It is the opinion of many that no fires should be set at all, except under a written permit from the Fire Warden of the district; no fire to be set in the forest without first clearing away a spot five feet from where the fire is to be set. The Act provides that lumbermen shall call their crews together, read the Act and warn them as to setting of fires.

The railway companies are required to provide their smoke stacks with a bonnet, or screen, interwoven at the draught with wires (three times as many wires for wood as for coal) and section men to pass over their sections once a day. The right of way to be cleared of all combustible material. A further Act provides that \$2,000 can be expended in any one year in carrying out the provisions as enacted. It is the opinion of many that while the provisions are to a large extent admirable, this Act can only be carried out by a well selected corps of foresters or fire wardens, permanently employed by the province, and along the same lines as the regulations of the province of Ontario. These

wardens could act as scalers of lumber, fishery and game wardens, Labor Act commissioners and in other capacities of a public nature. The outlay for such a service would be large, but the results would be far reaching and in the best interests of the province. There is no question in New Brunswick to-day of more importance than the preservation of the forests.

The total area remaining in the possession of the Crown, as stated at the outset, is in the vicinity of 7¼ millions of acres, of which quantity 6¼ millions are under timber license, the remaining one million acres being to a large extent burnt and barren lands. Licenses from the Crown are issued annually, but there is an understanding that they will run to 1st August, 1918. The stumpage on Spruce, Pine, Fir and Cedar is \$1.25 per M. sup. ft. and the yearly rental is \$8 per sq. mile.

The average annual cut for the last five years has been 120 millions of sup. feet, classified as follows:—

Spruce and Pine.....	95	millions	sup.	feet.
Cedar.....	15	"	"	"
Hardwood.....	4	"	"	"
Hemlock.....	3	"	"	"
Fir.....	3	"	"	"

Total.....120 millions sup. feet.

Twenty-six scalers are employed to survey this lumber. There is a chief scaler in addition, whose duty it is to oversee the scalers under him and report to the Department the various operations being carried on and the probable cut of each operator.

There are restrictions in the licenses as to the cutting of undersized lumber, and no tree is allowed to be cut down that will not make a log 18 feet long, and 10 inches at the small end. The Government have, at various times, been strongly pressed to allow undersized logs to be cut for pulp wood, but so far these requests have been met with refusal. In some sections where spruce has been found to be of a stunted or slender growth and would never mature to saw logs, the Government have allowed the lumber to be removed, but the quantity so cut has been very small indeed.

In administering the forests of the Crown, one of the greatest difficulties met with is to guard the Department against fraudulent applications for land, under the guise of settlement. The tendency in applying for settling lands is to secure a lot sufficiently timbered so as to allow the settler something at the start which he can turn into money, either by cutting the logs himself or selling his chance to someone else, which is directly contrary to the provisions of the Labor or Settlement Act. The greater number of those applying have no other motive than to cut off the timber, and then allow their applications to lapse. The Department is continually holding up applications where reports have shown that the lands are unfit for settlement. The licensees naturally protest against any such incursion into their limits, and the Department is left to adjudicate the matter, often to the displeasure of the settler or the licensees.

A common practice is to squat upon Crown lands, without application, clear a small portion and erect a hut. In time, the Department is forced, by some settling conditions, to approve his application, although in many cases the location is made among good timber. One can easily see the result. The cleared portion must be burned and the surrounding forest is at once placed in jeopardy.

The separation of purely agricultural lands from the lands only fit for timber growth is to my mind one of the greatest needs in our forests to-day. I have reference to lands at present only in the vicinity of settlement. Such an undertaking would no doubt involve a large expense. Only persons should be employed for this work whose judgment could be relied upon as thoroughly competent in judging the soils. Following this up with a corps of competent foresters for keeping down fires and supervising the cutting is the first essential to the preservation of our forests.

PRIVATE OWNERSHIP OF LANDS.

Of the lands that have passed from the Crown, I will only deal with three of the largest tracts. The grant to the New Brunswick Railway, for building a narrow gauge railway from Fredericton to Edmundston, a distance of 167 miles, was 1,647,772 acres, and embraces lands principally on waters tributary to the

River Saint John and including parts of the Counties of York, Carleton, Victoria and Madawaska.

Mr. W. T. Whitehead, the company's agent, has this year given me the following estimate of the quantity of lumber on these lands:

Spruce.....	3014	millions	sup.	feet.
Fir.....	3014	"	"	"
Hardwood.....	4743	"	"	"
Cedar.....	406	"	"	"

11,177 millions sup. feet.

Of this large tract the Company has sold only 600 acres. Fully one-third is situated on the upper Silurian formation, representing some of the best settling lands in the province, but as the policy of the Company is not to sell any for farming purposes, the progress of that section of the province is consequently retarded.

It has been proposed that the Government should buy back the settling portions of these lands, which if accomplished at a reasonable price, would, in the opinion of those who have studied the question, be productive of great results.

The next largest ownership is that of the Alexander Gibson Company, who hold the fee simple on upwards of 225,000 acres located principally on the Nashwaak River, and absolutely controlling the lumber lands on that river. Mr. Gibson purchased the greater part of these lands in the early sixties and has been cutting them ever since, without a break. The growth is principally black spruce, which replenishes itself about every ten years, in cutting down to merchantable logs.

In a conversation I had with Mr. Gibson, some ten years ago he estimated these lands as worth to him twenty dollars per acre. It must be understood, however, that any such high valuation can only be explained by the peculiar advantages possessed by the owner. Over 1000 millions of spruce have been cut on this property since Mr. Gibson's purchase, and judging from reports, the lands to-day are fairly abundant in timber. It may be mentioned here that as much as 20,000 sup. ft. per acre of spruce has been cut on choice bits of this property. In this connection I may mention the cut on a block of 3000 acres I purchased on the Keswick River, in the year 1887, a tract not particularly well timbered, but fast growing black spruce. In that year I let the stumpage on one million feet, again in 1892 it produced two million feet, and again in 1900 the operator paid me stumpage on two millions more. In 1907 I am looking for a further crop of two millions. So much for the old Scotch proverb—

"Be aye stickin in a tree it'll be growin' when ye're sleepin'".

The lands of Mr. Gibson have not been subject to much forest fire, partially owing to the distance from railway lines, but more particularly to vigilance which the owner displays in dry times.

Another large tract is that located on the upper waters of the South-West Miramichi, embracing an area of 160,000 acres, which I understand has lately passed into the hands of an American syndicate, at a price of upwards of \$600,000. The timber growth is much the same as on Mr. Gibson's property.

SURVEYS OF TIMBER LINES.

No timber lands can be properly managed without a system of carefully prepared surveys and block timber lines, as well as accurate maps. Generally speaking the Crown lands are blocked off into areas of six square miles, the lines running astronomically north and south and east and west, 2½ miles each way. On some rivers, blocks are laid off 5 miles each way, and in the Restigouche country the blocks are as small as 1,000 acres. The practice is to run the base lines 5 miles apart and large expenditures have in this way been made by the Government. The sub-divisions of the licenses are surveyed after first getting an order from the Crown Land Office, accompanied by a plan, showing in detail previous lines run, while the order contains a description of the lines to be surveyed. All these surveys have been made by blazing lines through the forests with the ordinary compass. The system is open to considerable objection, but it has been found practically to satisfy those whose interests are involved.

A recommendation has been made to erect iron monuments at the corner of blocks, it being found that corner posts soon decay, or are swept away by fires.

VALUES OF TIMBER LANDS.

My experience would warrant the statement that timber lands have doubled in value within the last ten years.

For the right to cut on Crown lands, not including stumpage, fairly good timber lands would be worth \$200 per sq. mile and first-class lands \$500 and over a square mile, according to location. The price of soil right lands has probably increased in the same proportion, prices ranging from two to five dollars per acre, although some properties have lately been sold much above these figures and running as high as ten dollars per acre for prime black spruce lands, easy of access and comparatively free from fire danger.

In summing up this paper, which has already grown to too great a length, I would recommend:

- 1st. More effectual means for the protection from fires.
- 2nd. The separation of the timber lands from agricultural lands.
- 3rd. A carefully selected corps of permanently employed foresters.
- 4th. Restrictions as to the cutting of undersized lumber.

Perhaps I may be expected to add re-forestation, and while much can be said about tree planting, I am of the opinion our efforts at present will be better met by a more efficient preservation of our forests, and more careful cutting of the standing timber. New Brunswick has yet a noble heritage in her forests. Let us then work together to preserve this heritage so that we ourselves and future generations may reap the benefits which Nature has so lavishly bestowed.

In conclusion, again, let us not forget the old Scotch saying—

"Be aye stickin' in a tree it'll be growin' when ye're sleepin'."

Fredericton, N.B., Feb. 28th, 1905.

GRINDING KNIVES.

A man who was in charge of the grinding room of a mill with the knives for three large planers and seven flooring machines, with a foreman who insisted on four knives on each head, had the balancing part of the business about as fine as we have ever seen, says a correspondent of *Dixie*. He would set his knives on the grinder by a stop on the back edge, and he was so well posted on his machine that he would adjust the stop of the feed of the grinder to just what experience had shown was required to allow for the wear of the wheel in use. The writer knew of his grinding eight pairs, sixteen, 30-inch knives, with but two of the lot requiring anything being done to make them balance with the other one of the pair they were ground to go with. Those that did require work to balance were placed on the grinder again and a few passes across the wheel was all that was needed. He had his balance scales on a bench, handy to the grinder, and when the first knife of the pair was ground, the scales were set for it, and as soon as the second knife was ground it was tried; if there was to be any change, it was made then, before starting on another set.

PERSONAL.

Mr. J. S. Larke, Canadian Commercial Agent for Australia, has received permission to return to Canada to study trade conditions.

Dr. Judson F. Clark, Provincial Forester for Ontario, has been elected a Fellow of the American Association for the Advancement of Science.

Mr. W. S. Hanbury, son of Mr. John Hanbury, of the Hanbury Manufacturing Company, Brandon, Man., has been attending the Technical School in Toronto during the past winter and expects to return west next month.

A SATISFACTORY INVESTMENT.

The New Century Refrigerator Manufacturing Company, of Dundas, Ont., who have had an advertisement in the CANADA LUMBERMAN during the last six months, write under date of the 8th inst.: "We are sending you renewal contract which we hope you will have attended to as early as convenient. We are constantly receiving enquiries from the advertisement in your publication."

THE Canada Lumberman

AND WOOD-WORKER

(Monthly and Weekly Editions—One Dollar Per Year.)

PUBLISHED BY

The C. H. Mortimer Publishing Company
of Toronto, Limited,

CONFEDERATION LIFE BUILDING, TORONTO

BRANCH OFFICES:

38 ALLIANCE BUILDING, MONTREAL
720-721 UNION BANK BUILDING, WINNIPEG
22 GREAT ST. HELENS, LONDON, E. C.

The LUMBERMAN Weekly Edition is published every Wednesday, and the Monthly Edition on the 1st day of every month.

TERMS OF SUBSCRIPTION:

One Copy, Weekly and Monthly, One year, In advance, \$1.00
One Copy Weekly and Monthly, Six Months, In advance, 50
Foreign Subscription, \$2.00 a Year

ADVERTISING RATES ON APPLICATION.

THE CANADA LUMBERMAN AND WOOD-WORKER is published in the interest of and reaches regularly persons engaged in every part of Canada in the lumber, wood-working and allied industries. It aims at giving full and timely information on all subjects touching these interests, and invites free discussion by its readers.

Special care is taken to secure for publication in the WEEKLY LUMBERMAN the latest and most trustworthy market quotations throughout the world, so as to afford to the trade at home and abroad information on which it can rely in its operations.

Advertisers will receive careful attention and liberal treatment. For manufacturing and supply firms wishing to bring their goods to the attention of owners and operators of saw and planing mills, wood-working factories, pulp mills, etc., the CANADA LUMBERMAN AND WOOD-WORKER is undoubtedly the most direct and profitable advertising medium. Special attention is directed to "WANTED" and "FOR SALE" advertisements, which are inserted in a conspicuous position on front page of the Weekly Edition.

THE STAKING OF CARS.

Through the Ontario Lumbermen's Association, the shippers of lumber have made an appeal to the railroad companies in the matter of furnishing car stakes on flat or gondola cars. It is contended by the lumber fraternity that the railroads should be compelled to provide such stakes and that they should be treated as part of the equipment, or if furnished by the shipper that due allowance should be made by the railroad.

The average cost of staking a car is perhaps about \$1.50, and, considering the large quantity of lumber that is shipped in flat cars, this means no small outlay by the lumber industry for equipment which should rightfully be provided by the railroads, for there seems no good reason why they should not be compelled to equip cars for the handling of lumber as they do for handling other freight. We understand that a very satisfactory permanent equipment can be provided at a cost of about \$7 per car, and the railroads would probably find that many advantages would accrue to them as the result of such permanent equipment.

The railroads doubtless favor the shipment of lumber in flat cars, but on account of the expense and trouble involved in providing stakes some manufacturers ship their lumber exclusively in box cars, with the result that the tonnage per car is usually less than if shipped in flat cars. It is possible to load a flat car with the lighter woods, such as hemlock, pine and basswood, up to 25,000 feet.

The National Wholesale Lumber Association have taken up this question very earnestly. The committee which has been making investigations have reported that some of the railroads are now providing staking equipment, and efforts are being made to have the plan universally adopted. It is believed that the railroads can no longer resist the logical de-

mand for fair treatment on this score, but it could hardly be expected that they would furnish such equipment so long as the lumber trade made no demand for it.

BRITISH COLUMBIA LOGGING LICENSES.

Suggested amendments to the British Columbia Land Act have been the cause of several recent meetings of persons identified with the logging industry, as well as of the expression of views somewhat antagonistic to the proposed regulations. Under the existing laws, there are two methods of acquiring timber lands in British Columbia. The older plan is by application for a lease for 21 years. This application is made in such a way as to give publicity to the intentions of the applicant, with the result that there is likely to be competition for the lands and the Government is assured of realizing a reasonable price. The other method, of more recent origin, is to take out a special license, which entitles the holder to not more than 640 acres, for which he pays \$115 per square mile per year if the lands are situated east of the Cascade Range of mountains, or \$140 per mile if situated west of the Cascade Range. Such a license is renewable only at the discretion of the Chief Commissioner of Lands and Works.

The operation of the special license law has not given satisfaction to certain loggers, who contend that they are unable to obtain accommodation from the banks owing to the fact that no guarantee is given that the license will be renewed from year to year. Accordingly, they have asked for amendments to the Land Act to enable present holders of special licenses to convert such licenses into twenty-one year leases. A section of the amendment reads:

"It shall be lawful for the Lieutenant-Governor-in-Council to grant to the holder of any special timber license, or his assigns, a lease of the timber lands described in such license, either separately or in conjunction with other timber lands so held, for a period of twenty-one years, subject to the payment by the holder of such lease of the sum of \$115 per square mile per year if such lands lie east of the Cascade Range of mountains, or of the sum of \$140 per square mile per year if such lands lie west of the Cascade Range, and all holders of special timber licenses shall, in order to entitle them to the benefits of this section, be required to surrender any and all special timber licenses held by them within three months from the passing of this enactment, and such leases shall be transferable."

It is also provided in the proposed amendments that the royalty payable to the Crown on timber cut on special license lands shall be 60 cents per thousand feet board measure, instead of 50 cents as at present.

Loggers are not unanimously in sympathy with the proposed changes, as many persons believe that if the special licenses are made assignable and renewable to any greater extent than at present, or converted into leases at the option of the holder thereof, the lumbering industry of the province may be seriously jeopardized. They point out that the machinery would be provided by means of

which much available timber might pass into the hands of capitalists, who would dominate and dictate the price of logs and thus retard the growth of the lumber industry.

Conditions in British Columbia are such that the Government must duly consider the interests of both the logger and the mill owner and at the same time endeavor to prevent the spoilation of the forest resources by unscrupulous speculators. One thing to be much desired in connection with the timber laws is stability, and for this reason it behooves the Government to aim to adopt something in the nature of a permanent timber policy.

LUMBER GRADING.

Disputes arising out of the disparity in lumber grading continue to reach us from all parts of Canada, although the larger percentage of such disputes brought to our attention have been confined to the hardwood trade. The large number of small mills employed in cutting hardwoods is doubtless responsible for this latter condition. There are no recognized rules to guide the manufacturer, and if he be "new" in the business, he must learn the custom of the trade, so far as any custom exists, as best he can.

That no standard system of grading has been adopted is due to the indisposition of a sufficient number of the trade to take the initiative rather than to an undue recognition of the necessity for and the advantages of the adoption of uniform rules. Manufacturers, dealers and consumers have expressed themselves in favor of a more definite understanding between buyer and seller as to what shall constitute a certain grade of lumber, and at least in Ontario, which is the largest hardwood centre, there should be no insurmountable difficulties in the way of accomplishing this result.

Until such time as the grades of hardwoods are more clearly defined than at present, it will be found advisable, when dealing in lumber, to specify as minutely as possible the class of lumber which is intended to be supplied. For instance, disputes have arisen over the definition of the term "log run," as embodied in a contract, the seller usually contending that such a grade should include the mill culls, while the opposite view is advanced by the buyer. By inserting in the contract the words "mill culls out" or "mill culls in," as may be agreed upon at the time of the negotiations, the possibility of misunderstanding and dissatisfaction is removed. In this connection it may be mentioned that the rules of the National Hardwood Lumber Association and the Hardwood Lumber Manufacturers' Association of the United States specify that "log run" means the full run of the log with No. 3 Common out, the latter being equivalent to mill culls. The rules of the New York Lumber Trade Association, in effect April 13, 1904, also state that "log run is understood to be the run of the unpicked logs, mill culls out."

Mr. Isaac Kenwell, Indian Lake, N. Y., writes: "Any man who is interested in lumber can not invest a dollar to better advantage than by sending for the CANADA LUMBERMAN."

NEW PONY BAND SAW MILL.

The illustration on this page shows the new and improved Pony band saw mill recently placed on the market by the Connell & Dengler Machine Company, of Rochester, N. Y., which they claim will pay for itself in

This machine takes less than one-eighth inch kerf, using an 8-inch saw 18 gauge, and is a high-grade tool at a low price. Will saw a log 45 inches diameter, is well made and durable. Will stand to feed from 15 to 120 running feet per minute.

side of the hub to the center of the rim, giving it sufficient strength to bear any strain that is necessary to give the saw its proper tension. The lower wheel has a web center, and being much heavier than the upper one, acts as a check to keep the upper wheel from over running, thus preventing the saw from becoming slack on its cutting side. This wheel is provided with a throat piece and scraper, located so as to prevent anything from dropping down between the saw and the wheel, while both wheels are provided with oil boxes and scrapers to keep them clear of saw-dust and resinous accumulations.

To keep the saw clean a rack is used; this is filled with burlap or waste, saturated in a little oil. This arrangement makes a rubbing brush 3 feet long and is very effective in keeping the blade clean.

The upper wheel shaft is 4 inches in diameter, the lower one $4\frac{1}{2}$ inches, both being forged crucible steel, and with two self-aligning boxes 14 inches long, one on each side of the wheel. The upper wheel is strained by weight and lever, which being very sensitive, catches all the varying conditions of the saw, caused by expansion or contraction from heat, or by reason of anything getting between the saw and wheel. This combination of weight and lever is so fine that it is not necessary, when the machine is stopped, to ease up the straining screws to allow for contraction of the saw, as the tension is always equal whether the machine is running or standing still, thus avoiding breaking the saws from unusual strain.

Manufacturers of band sawing machines commonly tilt the upper wheel to make the saw run in its proper place, just as is done in small band scroll saws. It must be clear that this practice is wrong when applied to wide saws, for by tilting wide faced wheels nearly all the strain is given to either edge of the saw, thus stretching one edge more than the other, and causing the saw to break. According to our method, the upper wheel boxes are so arranged that the outside box is pivoted in the top of the outside supporting arm, while the inside one permits a cross-line, or side movement of the end of arbor opposite the pivot which is controlled by a screw and hand-wheel within easy reach of the operator. By this means the saw can be made to run with its teeth projecting over the edge of the wheels sufficiently to keep the set from contact with them.

There is also provided a screw adjustment to tilt the end of the upper wheel arbor to secure its proper alignment with the lower wheel arbor which, being once done, should remain so as long as they keep true, and all changes intending to cause the saw to run in a certain position on the wheels should be effected with the cross-line adjustment. The guide above the log is balanced, and can be raised or lowered rapidly by the operator without changing his working position, and can be drawn back to allow saws to be put on or removed. Hard wood, soaked in oil, is used with the end grain next to the sides of the saw to guide it, though any other material can be used if preferred.

The driving pulley is 30 inches in diameter, $8\frac{1}{2}$ inch face, and should run about 500 revolutions per minute. Shipping weight, about 9,000 pounds. Floor space over all, 7 feet 2 inches by 6 feet. Height from floor to top of wheel, 11 feet. Length of saw, 31 feet 6 inches.

Saw mill men who wish further information should correspond with the Connell & Dengler Machine Company, Rochester, N. Y.

The Bowman Lumber Company has been formed at Revelstoke, B. C., and has succeeded the Empire Lumber Company.

A substance called petrolignite is being adopted as a material for the decks of ships, being under trial in the French and German navies, as well as the British service. It is prepared from saw dust mixed with certain materials, and formed into slabs, under high hydraulic pressure, and has been placed upon the market in England. Its valuable properties are that it is non-inflammable and is not slippery when wet. It is said that it will not harbor germs, and that in tropical climates it will resist the attacks of white ants. It is very hard, and like hard wood, can be worked with tools into any shape.—Iron Age.

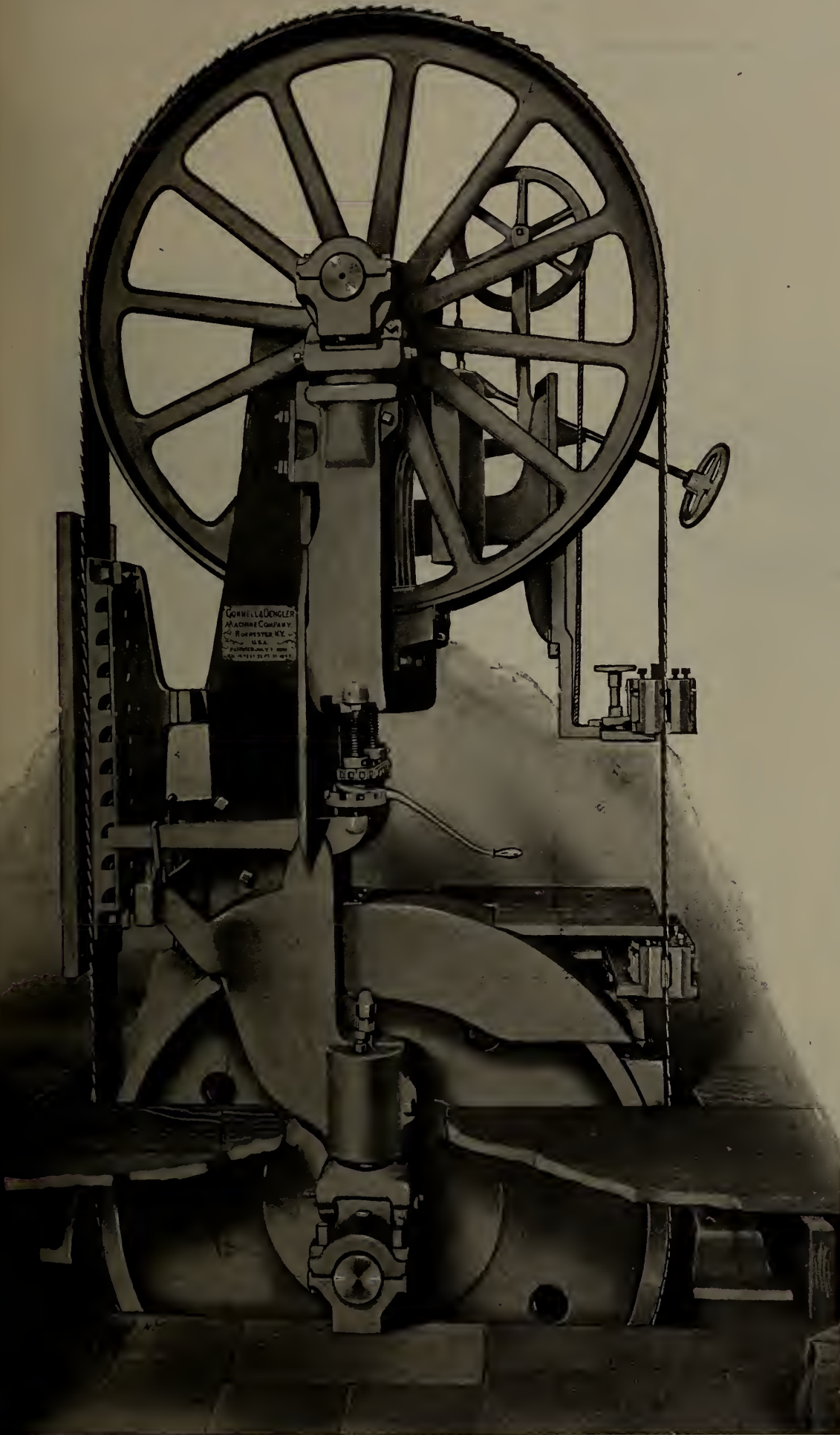

IMPROVED SIXTY-INCH PONY BAND MILL MANUFACTURED BY CONNELL & DENGLER MACHINE COMPANY.

a short time in lumber saved as compared with the use of the circular saw. Besides making better lumber it will save about a one-inch board on every eight cuts or one board in sixteen cuts over ordinary band mill. The following description of the mill is given by the manufacturers:

The wheels are 60 inches in diameter, $7\frac{1}{2}$ inch face, perfectly balanced and ground true by a special grinding machine which we make, (the same as for our band re-saws), for grinding and re-grinding the wheels without removing them from the machine. The upper wheel has spokes set in a bracing position from each

WESTERN CANADA

Western Office of The Canada Lumberman,
720-721 Union Bank Building, WINNIPEG, MAN.

THE MOYIE LUMBER & MILLING COMPANY.

One of the most up-to-date saw mill establishments in the mountain section of British Columbia is that located at Moyie and owned by the Moyie Lumber & Milling Company.

The company was organized in 1901 and reorganized in 1903. The officers are: Donald Grant, president; P. Ryan, vice-president; L.P.

The main building is 200 x 45 feet, but with the addition of the sheds extending on either side the width is increased to a maximum of seventy feet. It is equipped with one circular saw, gun shot feet, double edger, steam nigger, five saw slab slashers, two-man trimmer, three planers, one from the Benjamin Machine Company, of Chicago, for heavy timbers, and two

entire power equipment was supplied by the Diamond Iron Works Company, of Minneapolis, Minn.

The company own 250,000,000 feet of standing timber, about fifty per cent. tamarac, intermixed with fir, cedar, spruce and pine. Most of it is located around Lamb Creek and Moyie River. Outside of their present holdings, the



MOYIE LUMBER AND MILLING COMPANY—VIEW OF MILL, OFFICES AND OTHER BUILDINGS.

Doyle, secretary; M. Dreyfus, treasurer, and H. Cameron, manager.

When operations were commenced in 1901 the company built a small mill with friction feed with a daily capacity of 30,000 feet of lumber per day. This mill was operated until 1902, when it was entirely remodelled and extended, the new plant containing all the known specialties of the day. With these improvements came a vast increase in the output, which to-day stands at from 50,000 to 70,000 feet per

small ones from the Goldie & McCulloch Company, of Galt, Ont., together with conveyors, carriages, and a complete equipment of saw mill machinery usually found in a well equipped mill.

The logs are hauled up and cut by circular, then passed down live rolls and thrown by automatic steam transfer on to the edger. The sections then pass through the trimmers, where they are trimmed into different lengths. From the trimmers the lumber is passed to the

company are in a fair way to obtain possession of some three hundred million feet more adjoining their present holdings.

Most of the output, consisting chiefly of tamarac at the present time, is marketed in Manitoba and the Territories, although during the past few months, since the lead and silver mines of the Kootenay have begun to feel the benefit of the Government bonus, quite a large trade has been developed with them. One of the best of these is the St. Eugene, located on



MOYIE LUMBER AND MILLING COMPANY—END VIEW OF MILL, SHOWING BOILER HOUSE, JACK LADDER, REFUSE CONVEYOR, BLOW PIPE AND PART OF MILL POND.



MOYIE LUMBER AND MILLING COMPANY—LOADING PLATFORMS.

day. The mill is built on a site of 156 acres situated on the narrows connecting the Upper and Lower Moyie Lakes. It is one of the best locations in the interior, the Moyie Lakes being natural reservoirs and retaining without loss the entire cut of logs. A spur two hundred yards long connects the mill with the C.P.R. Crows Nest branch, providing excellent transportation facilities to all parts of the Territories and Manitoba.

sorting table, where it is graded and then passed on to the tram cars to be carried out to the piling grounds, there to await shipment to the Territories and Manitoba. All the slabs are passed on to the lath mill, which has a capacity of 18,000 per day.

Power for driving the machinery is obtained from a battery of two boilers and two engines of 120 h.p. for the saw mill, and one boiler and Corliss engine for running the planers. The

the top of the hill overlooking the town site of Moyie. It gives promise of being one of the best paying silver lead properties on the continent, development work being pushed with great vigor and thus creating a demand for a large supply of lumber.

President Donald Grant has for many years loomed largely in the forefront of railroad contracting, being one of the men who helped to build the C.P.R. Numerous other lines have

been constructed by him both in North and South America, one of the latest to be finished being a transcontinental road across Brazil. This enterprising gentleman hails from Fari-bault, Minn., where he has been for years a member of the firm of D. Grant & Company.

Mr. L. P. Boyle, the vice-president, is a Chicago capitalist. Mr. Ryan also hails from that city, although for many years he has been greatly interested in mining in Montana, Utah and Arizona.

Mr. H. Cameron, the manager, is a young man under thirty years old, who has been with



MR. A. CAMERON,
Manager Moyie Lumber and Milling Company.

the company since its origin, coming as an employee in a minor position. By dint of sheer ability, coupled with energy and hard work, he soon commanded the attention of his employers, securing promotion step by step, until to-day the mill and everything in connection with it has been placed under his care. He is ably assisted in his work by Mr. A. P. Stephenson, his accountant, another Chicago production.

The company have not taken out any logs this season, preferring to let their plant stand idle rather than attempt to market lumber under existing conditions.

The Paul Lea Company has been organized at Moncton, N.B., to operate a woodworking factory.

In "breasting" a saw to make it round, never buck the piece you joint with right up to the saw as if you were going to cut a piece of wood. The piece, whatever it is, should be passed back and forth in front of the saw, so when it is done the edge of the teeth will be square and full. If you jamb a piece of emery hard against a saw to joint it, it uses up about $\frac{1}{4}$ -inch before the teeth are filed down to a full point, and when this is done the saw will want jointing again before it will do good work. Most people think that a block of emery is just the stuff for this purpose, but unless you know how to use it, it is the poorest stuff in the world for this use. A good way to breast a table saw is to lift the table so that a piece of emery will just hit the teeth, and pass it back and forth across the saw.

PROMINENT BRITISH COLUMBIA LUMBERMEN.

HON. W. C. WELLS.

Two facts in connection with our common existence have been so often exemplified and proven that they have now almost become rules. With many they may still be proverbs that persistency in purpose always wins, and that ability is always discovered, but those who have striven with the life problem, or who have been close observers of commercial competition, readily acknowledge that these are rules which have few exceptions. Cincinnatus was found at the plow by the deputation which waited on him and extended the invitation that he become ruler of Rome, and the choice was never lamented. And so it has ever been further, to be successful in any line of business there must be a regard for the essential requirements, and the recognition and adoption of these requirements. Steady perseverance teaches that obstacles may be overcome and familiarizes one with those essentials necessary to successful attainment.

Wilmer Cleveland Wells lumbered on the Ottawa in the early seventies, and there learned the rudiments of the business which he has followed ever since. He had a mill at Hawkesbury, Ontario, but this was burned. To him who would succeed setbacks or failures are only instructive incidents, and Mr. Wells was not daunted. When the C.P.R. had completed its lines of steel to the Pacific coast, and rendered accession possible to the vast forest wealth of British Columbia, he was one of the first to recognize the possibilities. It requires considerable enterprise to start in a new country, where conditions are different, and a market for the product of which has yet to be developed. Twenty years ago there was practically no settlement in the great wheat-growing Territories of Canada; the richly mineralized Kootenay district of British Columbia was unknown even to the adventuresome prospector; the city of Vancouver had not been begun.

Civilization, however, follows the locomotive. In 1886, the year in which the railway was completed through to the Pacific coast, Mr. Wells went to Palliser, and erected the mill which has been in constant operation since. That he has got along in the worldly sense of the word is due to his adaptability to his new surroundings, and careful and steady attention to business.

He has personally conducted the enterprise, being assisted in later years by his son, Mr. George Wells. Last fall the capacity was enlarged from 45,000 feet per day to 75,000 feet, to meet the requirements of the developing trade in the Northwest. Palliser is known only because of these large mills, the inhabitants being these connected in some way with the operations. Therefore it is not strange that Mr. Wells is not a lodge man. The seeking of business, its cultivation, and attending to it, has been his chief aim, and he has succeeded.

Prominence in fields of commercial activity is always indicative of conspicuous ability, and a tribute to Mr. Wells' has been paid in his political preferment. Politics has been the only relaxation of his persistent career. In

1898, when turmoil prevailed in the Pacific coast province, there was need of good men in the legislative chambers. Those were the days of frequent elections, and much sorting of candidates. Three times Mr. Wells was elected by acclamation for the district of Columbia, and when Mr. Joseph Martin's Government was defeated he was elected by a large majority over two opponents. During the Dunsmuir administration he creditably held the portfolio of Lands and Works, continuing under the leadership of Hon. E. G. Prior. Then party politics was adopted, and Mr. Wells being a Liberal is now in the Opposition. Opponents attempted to cast a reflection on certain actions in connection with the interior administration of the Department of Lands and Works during the incumbency of Hon. Mr. Wells, but his hearty election by acclamation was the endorsement he received, which was regarded with satisfaction throughout the province.

Now he is mentioned in connection with the highest office that the country can bestow. The term of Sir Henry Joly de Lotbiniere as Lieutenant-Governor is about to expire, and the name of Mr. Wells is one of those suggested



HON. W. C. WELLS, Palliser, B. C.

as successor. While his natural reticence and not being as eagerly active as others for the honor may result in him not being accorded this distinction, it is a credit to his ability that he is mentioned.

Mr. Wells is well known in the East, for besides being a native of that part of Canada, he has frequently visited Ottawa, both as his official capacity when in the Government and as a member of delegations which have interviewed the Federal Government in respect to matters affecting the lumber industry in the West. He was born at Hawkesbury over 50 years ago, and was married to Isabella McDonnell, who died in 1901, and who is buried in a plot which overlooks the little town of Palliser.

HON. JOHN SHARPLES, M.L.C.
BY BRYON NICHOLAS.

The name of Sharples has been prominently before the public in connection with the timber and lumber trade of Canada for nearly three quarters of a century. The business of the firm was commenced in the City of Quebec by Mr. Wm. Sharples, who landed there in 1830, and the almost unprecedented success which has attended it ever since must, to a great extent, be attributed to the firm and broad foundations which he laid. For this undertaking he was admirably adapted not only by his innate integrity and business ability but also by his practical knowledge and experience, for he had been one of the most enterprising timber merchants of Liverpool for several years before coming to this country. Having seen his venture fairly started on the road to success, he placed it in charge of his son, Mr. Henry Sharples, he himself returning to England in 1840. Mr. H. Sharples was succeeded by Messrs. Richard Wainright and Charles Sharples, and they were followed by the late Hon. John Sharples, upon whose death the business passed to his sons, Messrs. William and John Sharples. The former died some twenty years ago, ever since which time the latter has been sole member of the firm.

The establishment transacts the greater part of its trade with the United Kingdom, but business relations are maintained also with certain commercial centres in continental Europe. There are branch offices at Montreal and Ottawa, and the firm have agencies in Glasgow, London and Liverpool. The development of the business of this concern from comparatively small beginnings has been something phenomenal, and it is gratifying to know that never, since its founder came to Canada, have its prospects been brighter than they are to-day, and never has the actual business done been nearly so extensive, despite the present temporary depression in the timber market in the old land. The firm possesses two coves, one of which is at Sillery and another at Bridgewater, situated a few miles up the river from Quebec. That at Sillery is for square timber, and that at Bridgewater for deals, etc. During the season there are exported from these coves some two million feet cubic of square and waney timber of all kinds, and about fifty million feet board measure of pine and spruce deals.

Now and then certain pessimistic people tell us that, what with reckless waste and devastating fires, our forest wealth is rapidly passing away; but those actually engaged in the timber trade assure us that we are only beginning to realize our almost illimitable resources in this respect, and that as railway after railway opens up vast tracts of country hitherto unexplored we are warranted in believing that these resources (with a prudent plan of re-foresting) are practically inexhaustible. The



HON. JOHN SHARPLES, M.L.C., Quebec.

latter position is certainly supported by the steadily maintained volume of exports from Quebec.

To those who know the Sharples firm it is needless to say that this immense business, like that of some other great Canadian concerns, has reached its present high level of prosperity through the honest industry of those directing it from time to time, their able management, their intimate acquaintance with all its details, their prompt and accurate fulfilment of every contract, and their generous treatment of those with whom they have dealings. Such methods have always characterized this firm from the very beginning, and never more so than now, for the present proprietor, Honorable John Sharples, preserves the tradi-

tions of the house unstained and unsullied. Of this gentleman it may be said further that the same excellent qualities which make him an ideal business man fit him also for certain other public and important positions to which he has been called, viz., those of a member of the Legislative Council of the Province of Quebec, and of the Quebec Board of Harbour Commissioners, Vice-President of the Union Bank of Canada, and of the Quebec Auditorium, a Director of the Quebec Bridge and Railways Company, President of The Chronicle Newspaper Company, Magor of the suburban town of Sillery, and, until he resigned recently, was Vice-President of the Great Northern Railway of Canada. To such able and upright men as Hon. John Sharples, Canada owes much of her present prosperity.

In politics Mr. Sharples is a staunch conservative, and in religion a Roman Catholic, being a trustee of St. Patrick's Church, Quebec.

THE JAPANESE MARKET.

Reporting to the Department of Trade and Commerce on the prospects for an increased market in Japan for British Columbia lumber, Mr. Alex. McLean, Trade Commissioner at Yokohama, says:

"There is nothing at present in the lumber market conditions out here to lend encouragement to the lumber industry in British Columbia. The situation has not improved since my reference to this subject some six months ago. A person coming from the strenuous activities of Canada, and looking at the conditions in the centres of trade population and the industries here, would be surprised to see stagnation in building and real estate improvements generally. The growth of the population of this country is very rapid, nearly five millions in ten years; the increase in the volume of trade is encouraging; and accumulated wealth is year upon year becoming more conspicuous. These are conditions of which increased building construction is usually the concomitant. Yet, one would think that everything in the way of building had been finished, and that the work going on would do nothing more than make good wear and tear. This is the situation as I have observed it throughout the highly representative district of urban and rural Japan from Tokio to Kobe; and I find no reason to doubt that it is so throughout the empire. This is not a natural state of things, and therefore may not be expected to continue under ordinary conditions."

**SPECIAL TO LUMBERMEN,
MINERS AND RAILWAY CONTRACTORS**



We are Manufacturers of

**MINCE MEAT, BAKING POWDER,
COFFEE, SPICES, FLAVORING
EXTRACTS, MUSTARDS, &c.**

And all kinds of Grocers' Sundries
for Camp Use.

Mince Meat put up in 75 pound Tubs, 1/2
Barrel about 300 pounds, Barrels about
600 pounds.

Special Attention Given to Mail Orders

**The Capstan Manufacturing Co., TORONTO,
ONT., CAN.**

CANADIAN OIL CO. LIMITED
STRACHAN AVENUE TORONTO, ONT.
**TO LUMBERMEN THE DOMINION OVER:
OUR TRADE WITH SAW-MILLS**

Has been large and satisfactory. We again solicit your
orders for the season of 1905.

Our Agents will call with "STERLING"

Cylinder, Engine, Dynamo, Machine, and SPECIALTY Oils,
Greases, Packing, Waste, Babbit Metal, Ready Mixed House
Paints, Varnish, Red and Black Roof Paint, Smoke Stack Black
for Boiler Fronts and Saw Mill Refuse Burners, White Lead, etc.

BRANCHES:

Petrolia, Ont.
London, Ont.

Hamilton, Ont.
"Soo," Ont.
Halifax, N. S.

Montreal, P. Q.
Winnipeg, Man.

Vancouver, B. C.
St. John, N. B. C.

**'STERLING'
OIL
'STERLING'
OIL**

CANADA LUMBERMAN

AND WOOD-WORKER

WEEKLY EDITION

The Lumberman Monthly Edition, 44 pages} \$1.00 PER YEAR {The Lumberman Weekly Edition, every week.

THIS PAPER REACHES REGULARLY THE PRINCIPAL LUMBER MANUFACTURERS AND DEALERS THROUGHOUT CANADA, AND WHOLESALE BUYERS IN GREAT BRITAIN, THE UNITED STATES, AND OTHER FOREIGN MARKETS.

VOL. XIII.

TORONTO, MONTREAL, WINNIPEG, MARCH 29, 1905

No. 9

CANADA LUMBERMAN

PUBLISHED BY

The G. H. Mortimer Publishing Co'y
of Toronto, Limited

Confederation Life Building - TORONTO.

Branch Offices:

38 ALLIANCE BUILDING, MONTREAL
720-721 UNION BANK BUILDING, WINNIPEG.
22 GREAT ST. HELEN'S, LONDON, E. C.

The Weekly Lumberman - Published every Wednesday, contains reliable and up-to-date reports of market conditions and tendencies in the principal manufacturing districts and leading domestic and foreign wholesale markets. A weekly medium of information and communication between Canadian timber and lumber manufacturers and exporters and the purchasers of timber products at home and abroad.

The Monthly Lumberman - A 14-page journal, discussing fully and impartially subjects pertinent to the lumber and wood-working industries.

WANTED AND FOR SALE

Advertisements will be inserted in this department at the rate of 15 cents per line each insertion. When four or more consecutive insertions are ordered a discount of 25 per cent. will be allowed. This notice shows the width of the line and is set in Nonpareil type; 12 lines make one inch. Advertisements must be received not later than 4 o'clock p. m. on Tuesday to insure insertion in the current week's issue

EXCELSIOR WOOD WANTED - PEELED basswood or clear spruce. RANKIN AND Co., Dundas street, Toronto. Telephone.

WANTED, - SLIDE VALVE OR AUTOMATIC engine, 100 to 150 h.p. Address, Box 202, CANADA LUMBERMAN, Toronto, Ont.

WANTED TO PURCHASE - SECOND HAND engine and boiler, 25 h.p., must be cheap and in good condition. RICHARD RALPH, Goldenburgh, Ont.

FOR SALE - 1", 6/4", 2" SOFT ELM. 1", 2", 3", Birch. 1" Wormy Chestnut. 1", 6/4", 2", 3", 4" Hard and Soft Maple. 1", 6/4", 2" Beech. 1", 2", 3", White Ash. 1", 2", 3", 4" Red and White Oak. Cedar Squares. R. E. KINSMAN, Hamilton.

FOR SALE

A GOOD 20 H. P. PORTABLE SAW-MILL, Address Box 200, CANADA LUMBERMAN, Toronto.

WANTED

Party with timber limits to form Company with a party who has a modern saw mill plant, capacity twenty million, on North Shore Georgian Bay. Address Box 193, CANADA LUMBERMAN, Toronto, Ont.

FOR SALE

2 500,000	Laths 1 1/2	Red Pine Mill Run
1,500,000	" 1 1/4	White Pine No. 2
70,000	feet	1 Good Spruce
100,000	"	1 Pine 2d qua. strips 12/16
230,000	"	1 " 2d qua. strips 12/16
700,000	"	1 " S.C. shorts 6/11
400,000	"	1 " S.C. strips 12/16
18,000	"	1 " Cut up sidings 12/16
30,000	"	1 " Cut up sidings 12/16
21,000	"	1 " Good Sidings 12/16

Apply to H. BOURGOIN, 71A St., James street Montreal, P.Q.

WANTED-A QUANTITY OF IRON RAILS for lumber tram cars, second hand. Apply Box "E," Gravenhurst, Ont.

WANTED-FROM ONE-HALF TO ONE million feet pine logs. State price and where stock can be watered. Address, "Pine," CANADA LUMBERMAN, Toronto, Ont.

SITUATION WANTED.

ADVERTISER, WITH GOOD CONNECTION in Toronto and district, desires to represent a good firm of lumber dealers, highest references. Apply Box 206, CANADA LUMBERMAN.

FOR SALE.

LUMBER AND SAW-MILL BUSINESS ON C. P. R. Main line. Mill in good running order. Daily sawing 20 to 25 M feet. Timber convenient to mill. Address A.B.C., CANADA LUMBERMAN.

FOR SALE-SAW MILL, CAPACITY 12 M. per day, with 65 acres of land at the Village of Barrys Bay, Ont., on the line of C.A.R.; also 3,000 logs, hemlock and basswood, and 100 acres of standing timber, with camp, stable and outfit, on waters of Barrys Bay, five miles from mill. Good timber country. Price, \$3,000. For particulars apply to N. D. MORRISON, Dalhousie Station, Quebec.

FOR SALE. - SAW MILL MACHINERY, nearly new, capacity 15,000 ft., 100 M feet hardwood logs, 300 M feet hemlock logs, three million feet hemlock and hardwood timber, 1,000 cords bark, 30,000 cords wood, complete logging outfit, quantity shingle bolts at mill and in bush. No dues. Close to G.T.R. Good timber locality. Reason for selling, failing health. For price and terms apply to Box 194, CANADA LUMBERMAN, Toronto, Ont.

POSITION WANTED

WANT TO ENGAGE FOR COMING SEASON as head Band Saw Filer, in large up-to-date Double or Single Cut Mill, where quality and quantity of lumber is an object; have had long experience in some of the best and fastest mills in the United States and Ontario, an expert on Double Cutting Bands, would take contract to file entire mill; not particular to location, expect good wages and will guarantee highest results, unquestionable reference on application. Apply Box 323, Port Huron, Mich.

FOR SALE.

Large Tract of Timber

in Central Ontario

THE PROPERTY OF
The Canadian Land and Immigration Company of Haliburton, (Limited.)

This company has a large tract of well timbered land about 125 miles north-east of Toronto. There are large quantities of Cedar, Hemlock, Spruce, Balsam, Basswood, Cherrybirch, Maple, also considerable Pine Elm and Ash on this tract. It is well served by two railroads one of which is about to be extended through the centre of the property. The Company are prepared to sell this timber in blocks ranging from 2,000 to 10,000 acres, or more if desired.

There are several good mill sites on the property. This would be a good opportunity for parties who are at present cut out and looking for a new location.

Maps and plans and further particulars can be had by applying to

W. H. LOCKHART GORDON,
Managing Director,
177 Bay Street, Toronto.

N.B.-Several parties have lately made considerable money by purchasing blocks of this timber and selling over again at an advanced price.

WANTED, 300,000 FEET WINTER CUT Basswood, Common and Better in quality, 1 1/16" thick when dry. Address Box 189, care of CANADA LUMBERMAN.

WANTED - TEN THOUSAND CORDS Hard and Soft Wood; also same quantity of Slabs. SIMCOE WOOD AND LUMBER CO., 52 Yonge Street Arcade, Toronto.

FOR SALE-A FEW CARS OF SOFT ELM, a few cars of soft maple and a car of hard maple. Could cut to order. Apply Box No. 201, CANADA LUMBERMAN, Toronto, Ont.

HAVE YOU ANY STOCK WHICH YOU wish to sell? If so, make the fact known to probable buyers by placing an advertisement in the Wanted and For Sale Department. Address, CANADA LUMBERMAN, Toronto.

WANTED-300,000 FEET BOARD MEASURE 3 1/2" x 4 1/2" x 10 or 20 feet long, small knotted red pine, free from wane. Kindly give price f. o. b. Montreal, immediate shipment. Address WILLIAM SMITH, 393 St. Antoine St., Montreal, Quebec.

"LOOK AT THIS"

FOR SALE-TWO GOOD WATER WHEELS, 40" and 48", also three run of stone, Smutter, elevators, etc., etc., for two hundred dollars F. O. B. cars here if taken this month. Box 4, Bothwell, Ont.

FOR SALE.

THE CUT OF 300 M. FEET OF BIRCH, 90 M. basswood, 50 M. soft elm, 25 M. black ash and 25 M. beech and hard maple. This is a well selected stock of No. 1 logs. Can be all cut to order. Address Box 04, CANADA LUMBERMAN, Toronto, Ont.

FOR SALE.

397,000 feet 2" x 4" and up, Norway Lumber, Log Run.
86,000 feet 1" x 4" and up, Norway Lumber, Log Run.
43,000 feet Mill Culls, etc.

Also the product of two million feet good white pine logs to be cut next summer. Correspondence solicited.

PINE LUMBER COMPANY,
Pine, Ont. (near Cartier.)

FOR SALE

1 15" Lathe, takes 3 ft. 9 in. between centres with 3 jaw chuck, cone 3 steps for 1 3/4" belt, with countershaft with tight and loose pulley \$60.00
1 15" Screw Cutting Lathe, takes 3 ft. 9 in. between centres with 4 jaw independent chuck, cone 4 steps for 1 3/4" belt, steady rest, countershaft with tight and loose pulleys \$80.00
1 24" Screw Cutting and Turning Lathe, takes 16' 6" between centres, bed 22 feet long, with 4 jaw independent chuck, 2 large face plates. Gap will swing 36", cone 4 steps for 3 1/2" belt, with countershaft, tight and loose pulleys \$200.00
Above lathes, suitable for saw mill or repair work, to be seen at SAINT JOHN IRON WORKS LTD., St. John, N. B.

ALSO

1 Second-hand Exeter Engine, cylinder 10" dr., 20" stroke, with flywheel 8' diameter for 14" face belt, Tandy Bed, all overhauled in good order. Practically new. Price F. O. B. St. John, N. B. \$325.00
1 Steeple Compound Marine Engine, H. P. Cylinder 7" diam., L. P. Cylinder 13" diam., Stroke 10", built to stand a boiler pressure of 150 lbs. per square inch under Dominion Act of Inspection of Steamers. Air, Feed and Bilge Pumps work off crosshead. Crank Shaft solid forging with half coupling keyed on, thrust bearing on bed of engine. Price F. O. B. St. John, N. B. \$400.00
SAINT JOHN IRON WORKS LTD.,
P. O. Box 391, St. John, N. B.

WANTED-ALL PULP MILLS AND PULP WOOD Companies to look up page 7 monthly issue, which is bound to interest you

WANTED - A MARKET FOR BASKET Bottoms, Spring Bed Sides and Broom Handles. Send dimensions and prices. Box 273, Huntsville, Ont.

LOGS

WANTED.-VENEER LOGS FROM 12 INCH up, birch, oak, ash, hemlock and basswood, delivered any railway station. IMPERIAL VENEER Co., LIMITED, Sundridge, Ont.

CEDAR FOR SALE

10,000 PIECES ROUND CEDAR, 8-16 AND 25 feet long, on the Vermillion river. Can be delivered at Spanish boom. Also Cedar, Pine and Spruce lumber for sale here at Larchwood on C. P. R. JAMES MCCREARY.

WANTED

FIRST-CLASS WHITE PINE AND SPRUCE culler, must have thorough knowledge of grading required for English and American markets (deals and sidings). Apply, Box 111, CANADA LUMBERMAN, Toronto.

CANADIAN TUGS FOR CHARTER FOR SEASON 1905

Tug Florence-Engine fore and aft compound 18 1/2" x 36" x 26. Large Scotch Boiler 12 1/2" x 1 1/2" and easy steamer.

Tug Home Rule-Engine High Pressure 22 1/2" x 24". Fire Box Boiler 8' x 14".
Tug Christian, S. J. (American)-Engine High Pressure 19" x 20". Fire Box Boiler 6 1/2" x 12".

For further information address HACKETT TUG LINE, Amherstburg, Ont.

FACTORY SITES WANTED

SLACK BARREL STAVE MANUFACTURER wants site with suitable timber near, and in Ontario.

Basswood tract of land with Mill or Site and reasonable railway facilities.

Large Paper and Pulp Site wanted with timber tract and waterway.

Other Factory Sites and Buildings wanted everywhere in Canada for American industries who are about to locate.

CHAS. F. ROLAND, Industrials, St. Catharines, Ont.

PULP MILL FOR SALE

The City of Saint John Offers for Sale That Valuable Property Known as the Saint John Sulphite Pulp Mill.

The mill has a capacity of 180 tons per week; was built of brick in the year 1898, according to all the requirements of the Factory Insurance Companies of Providence (R.I.), and is fitted with turbine water wheels, developing 600 H. P., and an auxiliary steam plant of 300 H. P.

It contains two steel digesters 14 x 45 feet, built by the Portland Company, Acid Department Milk of lime system, of abundant capacity. Paper machine contains 21 Drying Cylinders, 100 inches by 4 feet.

The situation is at the mouth of Mispec River, a stream ten miles in length, and is distant about seven miles by sea from the City of St. John. Barges carrying 700 tons of coal discharge at the mill. Schooners have frequently been loaded with pulp at the mill, whence they departed to New York.

Sealed proposals, endorsed "Tender for Pulp Mill," will be received by H. E. Wardroper, Esq., Common Clerk, at his office, City Hall, Saint John, N.B., up to 12 o'clock, noon, of Wednesday, the 26th day of April, 1905.

W. W. WHITE, Mayor,
Chairman Board of Water and Sewerage.

FOR SALE.—CEDAR POSTS AND CEDAR telegraph poles, in car lots. Apply, Jno. BLANCHET, North Bay, Ont.

WANTED.—A BAND SAW FILER FOR UP-to-date mill, must be first-class. Apply, TANNER BROS., Waubesa, Ont.

WANTED—2 TO 5 MILLION PINE LOGS, delivered in the Georgian Bay. State price and number of logs to the M. Apply Box 205, CANADA LUMBERMAN, Toronto, Ont.

BAND FILER WANTS POSITION. — A man, capable of handling sawmill, siber and industrious, 11 years experience, best of references. Address, "Electrician," CANADA LUMBERMAN, Toronto, Ont.

WANTED — SALESMAN WITH EXPERIENCE in Hardwood and Pine for Canadian and United States trade. Apply stating experience and salary expected. Address "Timber," care THE CANADA LUMBERMAN, Toronto.

WANTED.—GOOD PRACTICAL MAN WITH a good mill, must be good rig, with double edger and trimmers; also lath mill preferred, to cut about a million ft. pine. Price paid, \$3.00 for lumber, going price for lath. Address, W. B. McLEAN & CO., North Bay.

POSITION WANTED.

ADVERTISER (AGE 30) DESIRES POSITION, any kind of clerical work in lumber trade. Good references as to ability and character. Apply Box 207, CANADA LUMBERMAN, Toronto, Ont.

SAW MILL AND TIMBER LIMIT—NEW Ontario, two thousand five hundred cash; nine thousand five hundred, terms, purchases mill capacity 35 to 40 thousand; limit thirty-five miles away, adjacent to running stream, included in price; quarter section, 65 per cent. white pine; or will sell half interest for eight thousand, two thousand five hundred cash. Locators, Winnipeg, Manitoba.

SAW MILL AND TIMBER LIMIT, MANITOBA; annual turnover twenty-five thousand dollars; price mill twenty-five hundred, in four payments; limit 200,000 cords, ten thousand, five thousand cash, balance six and nine months; store in business; teams, horses, sleighs, etc. Locators, Winnipeg, Manitoba.

FOR SAW MILL AND TIMBER LIMITS throughout Western Canada write the Locators, Winnipeg, Manitoba.

SELLING AGENTS FOR B.C. SHINGLES.

Just as we go to press, it is learned that the Coast shingle manufacturers of British Columbia, at a meeting held a few days ago, appointed the Union Lumber Company and the Export Lumber and Shingle Company as their selling agents, sales to be apportioned. They also adopted the price list issued in March, 1904, less fifteen cents off number ones and five cents off number twos.

CURRENT TRADE CONDITIONS.

ONTARIO.

Manufacturers and dealers alike agree that there are no signs of depression in the lumber trade. On the other hand, the outlook for business is good, and in Toronto the season promises to be one of unusual activity. Every week permits are being issued for buildings representing a large expenditure, and, barring labor troubles, which do not now seem probable, this is likely to continue throughout the summer season. The manufacturing industries which consume lumber are also working to full capacity and general prosperity prevails.

A few large transactions in lumber have recently taken place which indicate confidence in present prices. It is the exception rather than the rule to meet a person who is disposed to predict lower values, and any movement in that direction must therefore lack the assistance of public sentiment. It would be unwise, perhaps, to advise the indiscriminate purchase of lumber at current prices, but the picking up of marketable stocks at favorable opportunities would seem to be a wise policy, as a firm lumber market for the next few months is altogether probable. There are many advocates of higher prices for hemlock, but until more definite information as to the log production of the past winter is obtainable, prediction is hazardous. There is but a small quantity of dry stock in first hands, and dealers have found it necessary to buy from each other to some extent in order to fill orders.

So far as can be estimated there has been a slight falling off recently in imports of yellow pine. This is believed to be due to the advanced prices adopted by the Southern Lumber Manufacturers' Association, making it more difficult to realize a margin on Canadian shipments.

QUEBEC AND NEW BRUNSWICK.

While the lumber trade in the Eastern Provinces is still quiet, the opinion is quite generally held that the season will be fairly prosperous. The manufacturers are receiving numerous inquiries for lumber for shipment to the Eastern States, which trade is likely to be greater than last year, when the Presidential election induced a

disposition towards conservatism. The smaller production of logs and the improvement which has already taken place in the British market are factors favorable to an advance in lumber prices. New Brunswick cedar shingles are exhibiting considerable strength and for the first time in many months sales of extras have been made for Boston delivery at \$3.35. Competition with red cedars is quite keen, and were it not for this fact it is believed that prices would soon advance 10 to 20 cents. The outlook, however, is more encouraging than for a long time.

UNITED STATES.

Reports from the different districts more uniformly favorable than at any previous time this year. Since the mild weather set in, the movement of lumber has steadily increased, until the volume now is in excess of that of one year ago, with indications of a further expansion in the near future. White pine, yellow pine, spruce and hardwoods are all showing renewed life, and conditions at the present seem to favor the holder of stocks. There has been an improvement in general industrial conditions and the outlook is for an active building season, circumstances which should have a strengthening effect upon the lumber market. The Southern pine mills are operating to their full capacity to meet the orders, and the output in any instances is sold far in advance. There is a steady demand for all kinds of hardwoods, whereas the supply of elm, ash and oak is none too great. Maple and basswood are to be had in larger quantities.

Prices show no particular change from last week. Mill culls are a little higher at Buffalo and Tonawanda, the scarcity of this grade making it an easy matter for

dealers to advance prices. Pine uppers continue to maintain the improvement previously noted.

Although the Pacific Coast mills have endeavored to adopt a uniform list on red cedar shingles, prices are still uncertain. Clears are showing an improved tone. New Brunswick cedar shingles are firmer, extras selling for Boston delivery at \$3.30.

W. C. CRAWFORD

Tilbury Ont.

Manufacturer of . . .

Handles—Axe, Fork, Pick, Etc.

Also Hard and Soft Wood Heading, an Red and White Oak, Maple and Elm Lumber. Can supply Second Growth White or Red Oak squares up to 38 in. long in large quantities.

THE KING AND BARTLES LUMBER CO.

PINE, POPLAR AND HARDWOODS

HEADQUARTERS Citizens' Building, Cleveland, O. HARDWOOD Distributing Yard McMinnville, Tenn. We buy and sell Pine in Car and Cargo Lots

M. & L. Samuel, Benjamin & Co.

103 Temple Building, Toronto.

EXPORT DEPARTMENT.

Correspondence solicited with exporters of wooden goods, such as Sanitary Woodenware, Broom Handles, Fork and Shovel Handles, Turned Goods, etc. Payments made on receipt of Bill of Lading at Toronto. European House, SAMUEL SONS & BENJAMIN, 16 Philpot Lane, London, Eng.

McLennan Timber Land and Lumber Co., Limited

Selling Agency and Dealers in all kinds of Timber Lands.

Offices: Quebec, 131 St. Peter St. Ottawa, Room 9, Central Chambers.

Herman H. Hettler Lumber Company

Manufacturers and Wholesalers of . . . **WHITE and NORWAY PINE LUMBER LATH and SHINGLES**

Shipments by Rail or Water

MIDLAND, ONT.

WOODS & SPICER, Limited

..... MANUFACTURERS OF.....

BRITISH COLUMBIA RED CEDAR SHINGLES

Capacity 100 Million a Year.

We have had over 15 Years Experience, and are not Asking our Competitors for any Pointers as to Quality.

Wire Your Orders at **OUR EXPENSE** to Agents, or to us at **VANCOUVER, B. C.**

KNIGHT BROTHERS CO. **KILN-DRIED BIRCH FLOORING** Send for Catalogue **KNIGHT BROTHERS CO.**
Burk's Falls, Ont. * * * Samples by Mail Burk's Falls.

Keenan Bros., Limited

Owen Sound, Ont.

HARDWOOD, HEMLOCK AND PINE LUMBER

We carry a full supply of native Hardwoods always on hand and solicit your inquiries. At the present time we have piled at outside points about 2,000,000 feet of Hardwoods, and about the same quantity of Hardwood, Hemlock and Pine piled here in Owen Sound, and we should be able to interest you if in the market.

WILL MAKE SPECIAL PRICES ON BROKEN LOTS AT OUTSIDE POINTS

ORILLIA PLANING MILL

Near G.T.R. Station

PLANING, MOULDINGS, MATCHING, FLOORING, RESAWING, SIDING

Done any quantity. Write for price.

S. POMEROY. Phone 311

MASON, GORDON & CO.

WHOLESALE TIMBER

Montreal, Quebec

Eastern Agents The B. C. Mills, Timber & Trading Co., Vancouver, B. C.

DOUGLAS FIR Timber in any size or length supplied WRITE FOR PARTICULARS AND QUOTATIONS.

EVERYTHING IN LUMBER AND TIMBER DRESSED AND IN THE ROUGH

BULMER, McLENNAN & COMPANY

MONTREAL, QUE.

Office and Yard, 571 DORCHESTER ST.

P.O.: B. 7 16

GREAT BRITAIN.

There has not been much improvement in the demand for lumber in Great Britain, but there is no doubt that a more hopeful feeling exists. The tendency of prices is to harden, as stocks on hand are held at considerably lower figures than new supplies can be bought for. Representatives of shippers have closed some business, but a few of the largest buyers are holding off in the hope that they may yet be given some concessions. The statistical position of Canadian lumber is very strong. Stocks of first and second quality white pine on the East Coast of England are practically exhausted. There is a very satisfactory demand for spruce deals and flooring, this trade being benefitted by the improvement in the cotton industry. The Liverpool correspondent of Timber says: "That there will be an improved consumption for 7 in. by 3 in. spruce goes without saying, and as this size forms such a great proportion of every cargo, it behooves sellers to consider whether it be wise for them to go on disposing of them at about cost price or something less. This is what happened all last year, and with what result? The idea was to restore the balance by adding an extra price to the 9 by 3 in. The result has proved to be that the bulk of the present holdings remain in 9 by 3 in., so that the desired return is still on paper, and may possibly be never realized. Would it not have been better in every way to have reduced quotations for the 9 by 3 in. and increased those for the 7 by 3 in.? This would have brought them

nearer together and held out a more solid inducement for consumers to have taken more of the wider widths."

NEW BRUNSWICK CEDAR SHINGLES.

Stocks of cedar shingles left in manufacturers' hands at the beginning of the winter were small and the winter production has been less than normal, as prevailing prices did not show much, if any, margin of profit. Orders accepted during the last month will virtually clean up all Extras, Clears and 2nd Clears left in Eastern Canada. The winter mills are now closing down and the summer mills cannot start before the middle of May, as they have to wait for their logs to come down. Many of the operators have already booked orders at advanced figures for May shipment. The market is, therefore, now nearly bare, very few shingles can be cut before May 15th, and a portion of the May output is already sold. This constitutes an extremely strong situation and is sure to be emphasized as soon as the New England retailers shake off their winter lethargy and start in to replenish their now rapidly dwindling stocks. Trade prospects in the Eastern States are better than for many years, and unless labor troubles or some entirely unforeseen business calamities intervene, consumption will be very large throughout the entire building season. One large producer of shingles is building two additional mills, but the operators in general have taken out no more logs than last year and in some sections the cut will be slightly

curtailed. Present indications would show that the spring demand will not be satisfied before mid-summer and in the meantime prices will rule very firm. It is a little early as yet for the placing of any large amount of business, but we believe shingles will be much sought for and orders very plentiful within three or four weeks. Orders for immediate shipment are very hard to place right now. Standard brands are quoted for May delivery as follows, f.o.b. Boston points: Extras, \$3.35 to \$3.40; Clears, \$2.90 to \$3.00; 2nd Clears, \$2.35 to \$2.40; Clear Whites, \$2.25 to \$2.30. The scattered remnants of the small winter mill cut are being offered at 5 to 10 cents less, but there are very few left unsold. Clears are in least supply and best demand and are comparatively stiff, although the entire list is now strong. It will probably be the part of wisdom for the manufacturers to refrain from taking advance orders this spring at anything less than full market quotations.

STOCKS AND PRICES.

S. E. O'Brien, Secretary of the Ottawa Improvement Commission, Ottawa, will receive tenders up to April 11th for the supply of timber required by the Commission during the current year.

J. J. Hale, of Woodstock, N.B., states that the logging operations at the head of the Tobique river the past winter amounted to only about half those of last season.

White, Rider & Frost, of Tonawanda, N. Y., are reported to have purchased about 35,000,000 feet of lumber to be shipped to their yard at Tonawanda Island upon the opening of navigation. DeLaplante & McBurney have also secured a considerable quantity of pine lumber to go to Tonawanda this spring.

Twelve hundred pieces of rock elm square timber were taken out by William Clement near Traverse City, Mich., during the past winter for shipment to Quebec.

L. Dean Holden, Pres. J. M. Diver, Gen'l.-Mgr
A.F. Holden, Vice-Pres. E. C. Barre, Ass't Mgr

The Cleveland-Sarnia Saw Mills Co., Limited.

Manufacturers and Wholesale Dealers in

Timber, Lumber, Lath and White Pine Shingles

Special Bills Cut to Order in White Pine, Norway and Fir, any length from 10' to 60' long.

SARNIA, ONT.

J. B. Farwell & Son

CONTRACTORS AND DEALERS IN . .

Canadian Cedar Telegraph, Telephone and Electric Light Poles

Bancroft, Ont., and Oswego, N. Y.

ROBERT WATT

WIARTON, ONT.

Manufacturer and Dealer in

Hard and Soft Wood Lumber, Lath, Shingles, Cedar Posts and Ties.

SPECIAL: One car load of 3x4 Hardwood Hearts suitable for car stakes One car of 3" Cedar Plank One car each of XXXX and XXX Cedar Shingles. One half car each of XX and X Cedar Shingles. Prices on application.

C. S. POWELL & CO. Lumber Exporters

604 Temple Bldg., TORONTO and at NEW ORLEANS, LA.

To Millmen Cash buyers all kinds hardwoods. We solicit correspondence . . .

THE IMPERIAL LUMBER CO., LIMITED

SAW AND PLANING MILLS, WARREN, ONT.

RED AND WHITE PINE DEALS

All kinds of SAWN LUMBER By Carload or Cargo.

BRANCH OFFICE, MANCHESTER, ENG. Head Office, TORONTO, CAN.

Registered Cable Address, "Pinewood," "American Lumberman" Telecode.

R. H. ROYS, Pres. RALPH LOVELAND, Vice-Pres. C. A. KENT, Sec'y. R. S. ABBOTT, Treas.

SAGINAW, MICH.

SAGINAW LUMBER & SALT CO.

MANUFACTURERS OF

LUMBER AND SALT

Mills at Sandwich, Ont.

J. D. SHIER LUMBER CO., LIMITED BRACEBRIDGE, ONT.

MANUFACTURERS OF

LUMBER, LATH AND SHINGLES

Pine, Hardwood and Hemlock Floorings and Ceilings. Sash and Doors, Wood Turnings etc. All Dressed Lumber Kiln Dried if desired End Matched Flooring a Specialty.

GOOD PINE SIDINGS A SPECIALTY

Planing, Matching, Resawing, etc In Car Lots.

Manufacturer of Doors, Sash, Mouldings, Ceilings End-Matched and Bored HARDWOOD FLOORING A SPECIALTY.

Lumber Kiln Dried in Any Quantity.

J. R. EATON - Orillia, Ont. Correspondence Solicited. Phone No. 54.

THE CHARLEMAGNE & LA OUAREAU LUMBER CO., LIMITED

404 Coristine Building, MONTREAL, P. Q.

Mills at Charlemagne and Montcalm on Great Northern Railway.

SAWN AND DRESSED

LUMBER

Clapboards, Shingles, Laths, Butter Boxes

Write us for quotations. Shipments by rail or water.

CACHE BAY LUMBER INDUSTRIES.

Geo. Gordon & Co.,

Manufacturers of RED and WHITE PINE

Band - Gang Circular

LUMBER AND LATH

CACHE BAY, Ont.

C. P. R.

26 miles West North Bay

THE LONG LUMBER COMPANY

The business formerly conducted by Morris S. M. Long will henceforth be carried on by The Long Lumber Company. Change name because Guy H. Long comes in as partner.

We trust to merit a continuance of the good will and confidence enjoyed in the past.

HAMILTON

J. D. SINCLAIR

Vancouver Cedar Mills

VANGOUVER B.C.

FOR

High Grade

Cedar

CACHE BAY PLANING MILL CO.

... MANUFACTURERS OF ...

MOULDINGS

CEILING

FLOORING

WAINSCOTING

SHEETING

CROSS ARMS CROSS ARMS

All kinds of Dressed and Pine Lumber.

Cedar Cove Mill,
Vancouver, B.C.

E. H. HEAPS & CO.,

Ruskin Mill
Ruskin, B. C.

Vancouver, B. C.

Lumber, Lath, Shingles, Doors, Mouldings, Etc.

SPECIALTIES :

AA1 HIGH GRADE CEDAR SHINGLES.

Cedar Bevelled Siding, Cedar Door and Sash Stock, cut to size, Cedar Finish, Base, Casing, Newels
Balusters, etc. Douglas Fir Timber up to 85 feet in length.

W. J. SHEPPARD, PRESIDENT
Waubesahe, Ont.

J. G. SCOTT, GENERAL MANAGER
Vancouver, B.C.

Pacific Coast Lumber Co.

LIMITED

VANGOUVER, B.C.

MANUFACTURERS OF

Fir, Cedar and Spruce Lumber, Lath, Mouldings, Turned Work, Etc.
High Grade Red Cedar Shingles

Ontario Representative, W. J. LOVERING,

112 Mail Building, TORONTO

D. C. CAMERON, President and Manager.

WM. ROBERTSON, Secretary.

J. E. YOUNG, Cashier

The Rat Portage Lumber Co., Ltd.

Manufacturers
of

**White and Red Pine Lumber, Lath, Shingles, Sash,
Doors, Turned and Band Saw Work**

Dealers in CEDAR POSTS, POLES and TAMARAC PILING

Mills at RAT PORTAGE and RAINY RIVER, Ontario, WINNIPEG, Manitoba, and VANCOUVER, British Columbia, Head Office: RAT POTRAGE, Ontario

Our Vancouver Mill cuts High-Grade Cedar, Fir, Spruce and Red Cedar Shingles. Winnipeg Mills cut Pine, Tamarac and Spruce Lumber
We also Manufacture all kinds of Mouldings, Sash, Doors, Turned Worked and Boxes. Correspondence solicited at all four points.

THOS. KIRKPATRICK,

MANUFACTURER OF

Red Cedar Shingles

Daily Capacity,
250,000

Mills at Hastings and New Westminster

Head Office: Hastings, B.C.

Orders Solicited and Correspondence Promptly Attended to. Telephone B 1425
Ontario Representative: W. J. SMITH, Fergus.

Export Lumber & Shingle Co.

Wholesale Dealers

Limited

British Columbia Lumber and Shingles

The management of this company have had a lengthy experience in manufacturing and selling British Columbia Lumber and Shingles in Canada and the United States, and are well informed as to the requirements of the trade in those sections.

We are in a position to make prompt shipments at current market prices.

Correspondence and inquiries for prices and other information regarding British Columbia lumber conditions promptly answered.

YOUR TRADE RESPECTFULLY SOLICITED

VANCOUVER - BRITISH COLUMBIA

COOKE & TAIT

MANUFACTURERS OF ALL KINDS OF

B. C. FIR AND CEDAR LUMBER AND SHINGLES

Saw Mill, Planing Mill and Shingle Mill: False Creek, Vancouver, B.C.

WRITE FOR PRICES.

Hazelmere Lumber Co.

HAZELMERE, B. C.

MANUFACTURERS OF

FIR, CEDAR and SPRUCE LUMBER

CLEAR CEDAR AND FLOORING

Our Specialty.

Long Distance Telephone.

W. C. WELLS

PALLISER, B. C.

Manufacturer of

High Grade Spruce, Fir, Cedar
and Lumber of all Descriptions.

CORRESPONDENCE SOLICITED.

CANADIAN MANUFACTURERS and WHOLESALERS

THE PEMBROKE LUMBER CO.

PEMBROKE, ONT.

We make a specialty of Dimension Stock in Pine, Spruce and Hemlock, and solicit your enquiries.

DELAPLANTE - McBURNEY LUMBER CO.,
WHOLESALE

White Pine, Hemlock, Lath, Shingles

Stocks in at { Collingwood Powassan Cartier Callander
Ontario { Midland Whitney Sturgeon Falls North Bay

TORONTO OFFICE : Room 503 Manning Chambers.

Office, Yards and Docks, NORTH TONAWANDA, N. Y. Send us your enquiries

FOR Pine, Hemlock, or Hardwood, Lumber and Timber, Telegraph Poles, Ties, Posts, Lath, Shingles, Dressed Lumber, Sash, Doors, Interior Finish, End Matched and Bored Hardwood Flooring, etc., try

JOHN HARRISON & SONS COMPANY, LIMITED

We have a complete stock, two Saw Mills running in summer and one all winter.

HEAD OFFICE, SAW AND PLANING MILLS, OWEN SOUND, ONT.

RHODES, CURRY & CO., Limited

LUMBER MERCHANTS.

Yards at Amherst, Little Forks, Sydney and Halifax.

BUILDING MATERIAL of all kinds carried in stock. We are buyers of Ontario Basswood, Elm and Pine.

Amherst, N.S.

Sawn and Hewn Spruce, Hemlock, Pine and Birch Timber, Spruce and Pine Boards and Plank, Birch and Ash Boards and Plank, Flooring, Shingles, etc.

JAMES J. MURPHY, Bank of Hochelaga Building **QUEBEC**

The Cook & Bros. Lumber Co.

MANUFACTURERS OF

Of Ontario, Limited
MILLS at SPRAGGE, Algoma Dist., Ont.
on "Soo" Branch C.P.R.

White and Red Pine
Lumber and Lath

OFFICES { Manning Arcade, Toronto
Coristine Building, Montreal
And at Mills at Spragge.

Water Shipments

THE M. BRENNEN & SONS MANUFACTURING CO., LIMITED

Saw Mills at RAINY LAKE, Ontario. Planing Mill and Head Office: HAMILTON, Ontario.

THE NIPISSING LUMBER COMPANY, LIMITED

Mills at CACHE BAY and SPANISH RIVER, Ontario.

Manufacturers of and Wholesale Dealers in all kinds of LUMBER AND LATH

Both Railway Delivery and Water Shipments. Correspondence Solicited. The NIPISSING LUMBER CO., Limited Head Office: HAMILTON, ONT.

AUGER & SON - Quebec
PULP WOOD AND TIES

Bought at Any Station.

Also Dimension Timber, Sawn to Sizes, Telegraph Poles and Lumber.—Write Us.

A. F. BURY AUSTIN
WHOLESALE LUMBER and TIMBER
CANADA PINE

Bank of Ottawa Building, 224 St. James St., - MONTREAL, CANADA

SPECIALTIES: Railway Bridge Timber and all kinds of Hardwoods; Ship Decking, Norway and White Pine, Dimension Timber, Norway Car Sills, Car Flooring, Telegraph Poles, Railway Ties, Oak and Whitewood, Planed and Rough Lumber, British Columbia Pine, Southern Pine, &c.; Birch Flooring, hollow back, end butted.

Sole Eastern Agent for The North Pacific Lumber Company, Limited, Barnet, B. C.

Douglas Fir Timber in any size or length up to 90 feet long, Timber Planers face up to 24 inch x 30 inch. Dry Kilns of large capacity. Rough and Dressed Lumber, Douglas Fir and Cedar.

WRITE FOR PARTICULARS AND QUOTATIONS.

R. LAIDLAW LUMBER CO.

18 Toronto Street, Toronto

JAS. PLAYFAIR.

D. L. WHITE.

PLAYFAIR & WHITE

Manufacturers and Wholesale Dealers

LUMBER • LATH • SHINGLES

Contractors for Railway Supplies
BILL TIMBER a Specialty

MIDLAND, ONT

A. & P. WHITE

Manufacturers of and Dealers in

Sawn and Planed Lumber, Dimension Timber. Joisting Car Sills, Car Flooring, Shingles and Lath.

PEMBROKE ONT.

F. MCGIBBON & SONS,

PENETANGUISHENE ONT.

Manufacturers of Pine, Hemlock and Hardwood Lumber, and dealers in Cordwood Hemlock Bills cut on short notice.

MAITLAND, RIXON & CO.

OWEN SOUND, ONTARIO.

Manufacturers and Dealers

LUMBER LATH, TIES, POLES, SHINGLES, ETC.

Make a Specialty of Long Pine, Cedar and Hemlock Bill Stuff. We ship by C. P. R., G. T. R., and by Water.

Turner Lumber Co., Limited

MANUFACTURERS

LUMBER and LATH

Shipments by Rail or Water. Midland, Ont.

HARDWOOD FLOORING

End Matched, Bored, Steel Polished, and Bundled

Send for Price List

A few cars of selected Maple and Birch and other Hardwoods at close price

THE SEAMAN KENT CO., Limited
160 Bay St., Toronto Factory, Meaford, Ont.

D. D. FLANNER H. W. REEVES
FLANNER & REEVES

Manufacturers and Wholesalers of

WHITE AND NORWAY PINE LUMBER

LATH AND SHINGLES

CAR AND CARGO MIDLAND, ONTARIO

THE MENZ LUMBER COMPANY

Manufacturers and Wholesalers

BRITISH COLUMBIA FIR, SPRUCE AND

CEDAR LUMBER, RED CEDAR SHINGLES

We Solicit Your Enquiries. J. F. FOSS, Manager. 624-625 Union Bank, Winnipeg, Man.

CEDAR LUMBER AND POLES FOR SALE

I can saw out to your order, during the winter months, bills in heavy square Cedar, or Planks.

Have also for sale a few cars of Poles from 25 to 50 ft.

Correspondence Solicited.

J. S. FINDLAY, OWEN SOUND, ONT.

and thence to Liverpool. The timber ranges from 25 to 65 feet long and averages 14 inches square. Thomas Denton, of Saginaw, is getting out about 50,000 cubic feet of elm and oak, also for the Quebec market.

The annual meeting of the Southwest Miramichi Log Driving Company was held at Fredericton, N.B., on March 21st. After the meeting Mr. Lynch, one of the contractors for the upper corporation drive, stated that the amount of logs to come through the booms this year would be between 20,000,000 and 25,000,000, as compared with 65,000,000 last year. Mr. Welch has given out the following estimates of the new and old logs to be driven on the Southwest Miramichi:

T. Lynch.....	7,000,000
M. Welch.....	6,000,000
Richards Co.....	8,000,000
Hutchinson.....	1,500,000
Jas. Fairley.....	300,000
W. R. McCluskey.....	600,000
Parties on Cains river.....	5,000,000
Parties on Renous river.....	12,000,000

Total.....49,400,000

The Cook & Bros. Lumber Company, of Toronto, have just sold nearly 34,000,000 feet of lumber to the Herman H. Hettler Lumber Company, of Chicago. The transaction includes all the dry lumber that is unsold now on the docks at Spragge, Ont., estimated at between 3,000,000 and 4,000,000 feet, and the lumber to be sawn this year, estimated at 26,000,000 feet of white pine and 4,000,000 feet of norway. The consideration is announced to have been between \$600,000 and \$700,000.

THE EASTERN LUMBER MARKET.

The Boston correspondent of the Lumberman's Review refers to the lumber market as follows:

Spruce has been very firm and brings full figures for both large and small lots. All of the Eastern mills have been booking orders freely, and in several cases important shippers are sold well toward the middle of the year for everything they can produce, and the market has toned up wonderfully and is to-day very firmly fixed upon a basis of \$19.00 for timber under 9" and \$21.00 for all stock running 9" and over. It is generally understood now that lumbermen in the North and East have caught every log possible during the past winter and will have a full supply with which to meet this season's demand. The English market for spruce has been toning up steadily and it is now believed that the Eastern Provinces will have scarcely a normal amount of spruce to send over the line to the New England and New York markets. The lath market is also very firm on a basis of \$3.40 for the 1 3/8" size and \$3.25 for the 1 1/2", and there is a great scarcity of lath at all points. The writer, while in the office of one of our largest retailers, learned that he had orders on his books for lath which would not only take all he had in the yard, but all he had bought and that he had bought every lath offered within the last three months and actually sent out inquiries in an effort to locate supplies for his spring trade. Eastern cedar shingles are just about steady on a basis of \$3.25 for extras and \$2.85 to \$2.95 for clears, with the latter grade in strong demand and well sold up. There is a fair supply of extras on hand at present, but an early Spring opening will

favor a strong shingle market as soon as the full force of the demand develops.

Hemlock is very firm, though the demand during the past month has been moderate. Stocks are light at all points, and with the selling price very firm on a basis of \$16.00, the outlook for a steady market is regarded as exceptionally good.

The hardwoods show little change during the month. Plain oak, either red or white, is about the strongest item on the list, though mahogany has come to the front again and is finding ready sale at full prices. Quartered oak, which has been a trifle druggy during the past six or eight months, is showing somewhat more tone, with most quotations for 1" 1s and 2s ranging from \$76.00 to \$80.00. In other respects the market is unchanged.

THE OUTLOOK FOR HARDWOODS.

The conclusion of the American Lumberman is that the outlook for hardwoods is very promising, as in the last issue we find the following remarks: Needs of consumers are sufficient to absorb practically all the hardwood lumber that can be produced and at this time, owing to the stimulated demand from all quarters, a prospective call for hardwood stocks in excess of the amount available for immediate use is to be anticipated. As will be remembered by those who keep in touch with this department of the lumber industry, stocks at the end of 1904 were relatively lighter than at the corresponding time in 1903. This condition was not only true with respect to manufacturers of hardwoods but with the consumer also. Evidently consumers thought to impose the burden of carrying stocks through the winter months on the manufacturer, with the ap-

parent expectation of buying stocks at the beginning of this year at about the same price they would have paid in the summer and fall of 1904. Their expectations are doomed never to be realized. Light stocks and unfavorable conditions for operating throughout the hardwood producing territory especially have created a shortage in the supply which will not be made good at a very early date. Many of the larger manufacturers with a better appreciation of the situation than have some of the consumers who are imbued with the idea that supplies will be forthcoming indefinitely, took a chance on the outcome a few months ago, and while they could have sold quarter sawed oak, for instance, at from \$65 to \$68 last fall, they held for higher prices which they today are securing. Not only have they been able to demand and receive the price for which they were willing to part with their stock eight months ago, but in addition a reasonable advance.

Evidently consumers have concluded to charge up to experience the difference between prices they are now paying for their stock and those at which it could have been secured last fall and are laying in supplies for future requirements. At least the consistent buying by the large users, which is general with the possible exception of the furniture factory districts, lends color to the belief that the consumer is out for all the hardwood stock he can get provided prices are within reach of his bank account. It is scarcely possible that hardwood values will dip below their present level during the remainder of the year and the shortage throughout the country may result in an agreeable manner to the producer who has the material to market.

UNITED STATES MANUFACTURERS AND WHOLESALERS

YOU
CAN
REACH

THE BONSAK LUMBER CO.
WHOLESALE HARDWOODS
ST. LOUIS
BY
RAIL, MAIL
WIRE OR
'PHONE

H. D. WIGGIN BOSTON, MASS.
89 STATE ST.
will inspect at mill and PAY CASH for

LOG RUN
Elm, Ash, Bass and other Hardwood
CORRESPONDENCE SOLICITED.

YELLOW PINE
We are in position to give first-class stock. Reasonable prices. Prompt shipments. Mills in Alabama, Mississippi and Arkansas.
MANN, WATSON & CO. Muskegon, Mich.

ONE DOLLAR
Will pay your subscription to the CANADA LUMBERMAN for
ONE YEAR

ACME LUMBER CO.
Grand Rapids, Mich., U.S.A.

Wholesale Hardwoods
Hard Maple and Rock Elm our Specialty.
We invite correspondence whether you wish to buy or sell.

CANADIAN LUMBER WANTED
We solicit consignments of long and short lumber from the Maritime Provinces and are prepared to purchase White Pine and Hardwoods in Ontario and Quebec.

ADDRESS:
CHAS. S. WENTWORTH & CO.
Room 510, 147 Milk St. - BOSTON, MASS.

THE ROBERT H. JENKS LUMBER CO.
CLEVELAND, OHIO
MANUFACTURERS AND WHOLESALERS OF
YELLOW PINE, POPLAR, HEMLOCK AND HARDWOODS
Yellow Pine Timbers a Specialty

Indiana Lumber & Veneer Co.
INDIANAPOLIS, IND.

Sawed and Sliced Quartered Oak a Specialty
Correspondence Solicited. **Veneers**

FRANK G. BURY **BURY & NOBLE** **MASON A. NOBLE**
WHOLESALE LUMBER - DETROIT **MICHIGAN**
Send us your inquiries for Southern Yellow Pine.

CHARLOTTE HAEBERLE
Wholesale and Retail Dealer in
YELLOW PINE and OAK TIMBER
Large stock of Timbers and Bill Stuff carried in stock.
All sizes and lengths for immediate delivery.
Telephone No. 10 - Cedar Street, NIAGARA FALLS, N.Y.

McGLURE LUMBER CO.
Wholesale Dealers in...
Hardwood Lumber

Carry in Stock and Have for Sale
ASH, BASSWOOD, BEECH, BIRCH, BUTTERNUT, CHERRY, CHESTNUT, COTTONWOOD, CYPRESS, ELM, GUM, HICKORY, MAHOGANY, MAPLE, OAK, POPAR, SYCAMORE, WALNUT, POLES (Oak, Hickory and Ash), RIMS and SPOKES (Oak and Hickory), OAK BENDING PLANK, OAK BILL STUFF, RAILWAY TIES.
Office and Yards: 520 to 530 Franklin St., DETROIT, MICH.
Correspondence invited on All Hardwoods.

CANADIAN LUMBER SHIPMENTS.

From Halifax, N. S. : Steamer Ionian, for Liverpool, 38,641 ft. hemlock deals, value \$386, 30,397 ft. birch deals, value \$291, 47,156 ft. spruce deals, value \$545, by S. Cunard & Co., agents. Schooner Calabria, for New York, 1,454,000 ft. spruce laths, value \$3,272, 127,000 ft. hemlock scantling, value \$1,143, by C. F. Longley & Co., agents.

From St. John, N.B. : Schooner Rewa, for New Haven, 178,938 ft. plank, 23,709 ft. scantling. Schooner Lena Maud, for Boston, 59,296 ft. deals, 65,591 ft. scantling. Schooner Abbie Keast, for City Island, 714,700 laths. Steamer Montroze, for London and Antwerp, 751 elm logs,

42 pcs. birch lumber, 383 bdls. pine boards, 4,165 pcs. deals, 27,000 bdls. shooks, 88 elm logs, 225 pcs. walnut lumber. Steamer Lake Erie, for Liverpool, 190 bdls. pine boards, 184,895 ft. deals, 146 elm logs, 3,675 maple blocks, 45 pcs. birch lumber, 25 birch logs, 3,462 pcs. deals, 142 pcs. ends, 444,636 ft. deals, 88,672 ft. scantling, 56,359 ft. ends, 231 pcs. oak lumber, 30 maple logs, 23 pcs. birch timber, 27 pcs. round timber, 3,145 maple blocks, 4,221 timber bolts. Schooner Avis, for New Haven, 73,816 ft. boards, 331,000 laths. Schooner Rebecca W. Huddell, for City Island, 258,195 ft. deals. Schooner W. H. Waters, for City Island, 156,445 ft. deals, 10,172 ft. scantling. Schooner Ravola, for City Island, 192,440 ft. deals.

Steamer Kastalia, for Glasgow, 12 maple logs, 12,000 ft. oak lumber, 91,223 ft. deals, 20 pcs. birch timber, 249,583 ft. deals, 6,657 ft. ends, 25,113 ft. scantling, 117,459 ft. birch plank, 24,581 ft. birch ends, 93 tons birch timber. Schooner Melville, for Cape Town, 3,385 ft. lumber, 1,098 pkgs. doors, 5,300 pcs. lumber, 428 bdls. lumber, 112,204 ft. lumber. Steamer St. John City, for London, 82,627 ft. birch plank, 10,831 ft. birch ends, 93,458 ft. deals. Schooner Lotus, for Fall River, 66,803 ft. plank, 77,692 ft. scantling, 4,309 ft. boards. Schooner Roger Drury, for City Island, 1,051,300 laths, 151,176 ft. deals. Schooner Three Sisters, for New York, 1,476,000 laths. Schooner Georgia, for City Island, 348,139 ft. deals. Schooner

Genevieve, for Stamford, Conn., 15,187 ft. plank, 60,416 ft. scantling, 515,000 laths. Schooner Pardon G. Thompson, 146,634 ft. plank, 33,178 ft. scantling, 6,460 ft. boards. Schooner Annie A. Booth, for City Island, 219,020 ft. deals.

Cable address: "Dundonian, Dundee."

BERG & SON,

Timber and Wood Pulp Agents and Brokers

DUNDEE, SCOTLAND

Contracts made between Shippers and Importers
Correspondence solicited

BRITISH WOOD BROKERS AND IMPORTERS

FARNWORTH & JARDINE

Wood Brokers and Measurers

Cable Address "Farnworth," Liverpool. 2 Dale St., 71 Regent Road **BOOTLE LIVERPOOL, ENG.**

F. A. Lightbody & Co.

8 Gordon Street - GLASGOW, SCOTLAND

WOOD BROKERS

Cable Address: "TENEBRIS," GLASGOW. Codes: A. B. C., A 1, "Zebra" and Private.

Agents for **CANADIAN WHITE PINE AND SPRUCE**; Hardwoods in Log, Etc.

Shipments handled to the best advantage to all ports in the United Kingdom Correspondence Solicited.

LOUIS BAMBERGER,

2 Broad Street Building, LONDON, E. C.

IMPORTER OF

Telegraphic Address "Bellywood, London."

Pine, Spruce and all Canadian Wood Goods

Are Open to Contract for *Glued-Up BASSWOOD KEYBOARDS*

ZEBRA CODE

A. B. C. CODE

DIRECTORY CODE

GELLIBRAND, HEYWOOD & CO.

Wood Agents and Brokers

Cable Address: "GELLICHT," LONDON 57 Gracechurch St. London, E.C. England

SMITH & TYRER

14 Tithebarn Street, LIVERPOOL

.. WOOD AGENTS ..

Cable Address—"Walmer," Liverpool.

Halifax, N.S., Office—SMITH, TYRER & Co., Metropole Bldg., Hollis St. Halifax, N.S

Edmiston & Mitchells

TIMBER BROKERS

Cable Address: "EDMISTON" Glasgow.

33 Renfield Street, GLASGOW

GANT & KEMP

TIMBER BROKERS

52 St. Enoch Square, GLASGOW

Cable Address: "TECTONA" Glasgow.
At and A B C Codes used.

Every lumberman wants it

35 cents buys it

Scribner's Lumber and Log Book

BRIMFUL OF EVERY-DAY

PRACTICAL INFORMATION

Address:

THE CANADA LUMBERMAN, Toronto

CABLES, DOORCHEEK, LONDON

We are Buyers of Pine Doors and Mouldings, Electric Wire Casings, W.C. Seats, Wooden Mantel Pieces, Sashes and Frames, and all kinds of ready made joinery.

LONDON STORES: Locke's Wharf, Edmonton, N.

STAVERS & STAVERS

OFFICES:

158, Leadenhall Street, London, E.C.

Manufacturers and Importers of

JOINERY

FELBER, JUCKER & CO.

Lumber Importers

MANCHESTER ENGLAND

Invite offers from Lumbermen for . . . Spruce Deals and Battens, Spruce and Pine Floorings, Shooks, Sashes, Mouldings, Dowels Broom Handles, Chair Stock, Seats, etc., or any Woods Suitable for English Market.

Telegraphic Address: FELBER MANCHESTER.

ASHTON & PETFORD

BISHOP LANE, - HULL, ENGLAND

BUYERS OF BOX SHOOKS

Invite correspondence from manufacturers who are in a position to export to Great Britain.

Cable address, "Shooks," Hull.
Codes—A. B. C. 4th Edition and Zebra.

JOSEPH OWEN & SONS, LTD.

Timber Importers

Cable Address "Owen Liverpool" Liverpool, Eng.

BUYERS OF

White Ash Logs and Planks.
Oak Logs and Planks.
Rock Maple Logs and Planks.
Rock Elm Logs.
Hickory Logs.

... ALSO ...

All classes of Lumber and Manufactured Wood Goods suitable for the English Market.

JAMES WEBSTER & BROTHER

BOOTLE, LIVERPOOL, ENGLAND

TIMBER MERCHANTS

BUYERS OF Oak, Birch, Ash, Grey Elm Logs and Lumber, Elm Staves and Heading, Handles of all description
Specialty

ALFRED DOBELL & COMPANY

WOOD AGENTS AND BROKERS

Liverpool and London Chambers - LIVERPOOL, ENGLAND

CABLE ADDRESS "DOBLE LIVERPOOL"

THOMPSON, BLOIS & KJELLGREN

ALL KINDS OF LUMBER AND LOGS

CASH ADVANCES MADE AGAINST SHIPPING DOCUMENTS

BRANCH OFFICES
41 Corporation St., MANCHESTER
Waterloo Chambers. GLASGOW

HEAD OFFICE

17 Gracechurch St., LONDON, E.C.

BRANCH OFFICE

Brook 1, HAMBURG

THE ONTARIO LUMBER CO. LIMITED

MILLS: North Bay, C.P.R. and G.T.R. Delivery.

MANUFACTURERS WHITE PINE LUMBER, LATH AND SHINGLES.

35 and 36 Home Life Building TORONTO, Ont. MILLS: French River, Georgian Bay Water Shipment Only.

WILLIAMSON & MORRISON LUMBER

Mills at L'Original, Ont.

HEAD OFFICE: 30 St. John Street, MONTREAL, P.Q.

WHOLESALE

JAS. LUNNY & CO., HINTONBURG, ONT.

Have for Sale {ASH, ELM, BASSWOOD, PINE, SPRUCE AND HEMLOCK IN QUANTITIES

Eastern Agents--B. C. Shingles and Douglas Fir, all dimensions Can dress to 24x30. B. C. Cedar Write for quotations

ONE DOLLAR

Will pay your Subscription to the Weekly and Monthly CANADA LUMBERMAN for

ONE YEAR

CURRENT LUMBER PRICES--WHOLESALE

TORONTO, ONT.

CAR OR CARGO LOTS.

Table listing lumber prices for Toronto, Ontario, including various grades of pine, spruce, and hemlock.

HARDWOODS--PER M. FEET CAR LOTS.

Quality, 1s and 2s unless; otherwise specified.

Table listing prices for hardwoods such as Elm, Hickory, Maple, Oak, and Walnut.

QUEBEC, QUE.

WHITE PINE--IN THE RAFT

Table listing white pine prices in the raft for Quebec, Quebec.

RED PINE--IN THE RAFT.

Table listing red pine prices in the raft for Quebec, Quebec.

OAK--MICHIGAN AND OHIO.

Table listing oak prices for Michigan and Ohio for Quebec, Quebec.

ELM.

Table listing elm prices for Quebec, Quebec.

ASH.

Table listing ash prices for Quebec, Quebec.

BIRCH.

Table listing birch prices for Quebec, Quebec.

OTTAWA, ONT.

MANUFACTURERS' PRICES.

Table listing manufacturers' prices for Ottawa, Ontario.

Table listing lumber prices for Bay City and Saginaw, Michigan.

BAY CITY AND SAGINAW, MICH.

UPPER AND SELECTS.

Table listing upper and select lumber prices for Bay City and Saginaw, Michigan.

FINE COMMON.

Table listing fine common lumber prices for Bay City and Saginaw, Michigan.

B FINE COMMON OR NO 1 CUTTING.

Table listing B fine common or No 1 cutting lumber prices for Bay City and Saginaw, Michigan.

STRIPS, A AND B (CLEAR AND SELECTS).

Table listing strip prices for Bay City and Saginaw, Michigan.

FINE COMMON OR C.

Table listing fine common or C lumber prices for Bay City and Saginaw, Michigan.

SELECTED NO. 1 SHELVING OR FENCING STRIPS.

Table listing selected No. 1 shelving or fencing strip prices for Bay City and Saginaw, Michigan.

BARN BOARDS OR STOCKS.

Table listing barn board or stock prices for Bay City and Saginaw, Michigan.

SHIPPING CULLS OR BOX.

Table listing shipping cull or box prices for Bay City and Saginaw, Michigan.

SHAKY CLEAR.

Table listing shaky clear lumber prices for Bay City and Saginaw, Michigan.

SHINGLES, 18-IN.

Table listing shingle prices for Bay City and Saginaw, Michigan.

LATH.

Table listing lath prices for Bay City and Saginaw, Michigan.

ALBANY, N. Y.

PINE.

Table listing pine prices for Albany, New York.

GEO. G. GLADMAN MANUFACTURER OF WHITE PINE AND HEMLOCK LUMBER LATH AND SHINGLES

Mills at Smith's Bay Township of Carling

PARRY SOUND, ONT.

CORRESPONDENCE SOLICITED

THE WOODSTOCK LUMBER & MANUFACTURING CO., Woodstock, Ontario. Manufacturers of and Wholesale Dealers in Pine, Hemlock & Hardwood Lumber

ENQUIRIES PROMPTLY ATTENDED TO.

A. P. EBERT MANUFACTURER OF AND DEALER IN

Pine and Hardwood Lumber, Lath, Shingles, Posts, Broom Handles, and Short Hardwood Dimension Stock WARTON, ONT.

THE NEW LINE

Through the Spruce Forests of the Laurentian Mountains--between Quebec and Hawkesbury.

WATER-POWERS, TIMBER LIMITS AND ELECTRIC POWER FOR SALE. IDEAL PULP-MILL SITES.

Unexcelled Export Facilities at Quebec.

A. J. GORRIE, General Supt. MONTREAL GUY TOMBS, G. F. & P. A.



Table listing lumber prices for Buffalo and Tonawanda, New York.

BUFFALO AND TONAWANDA, N. Y.

WHITE PINE.

(Wholesale selling price.)

Table listing white pine prices for Buffalo and Tonawanda, New York.

The following quotations on hardwoods represent the johher's buying price at Buffalo and Tonawanda:

WHITE ASH.

Table listing white ash prices for Buffalo and Tonawanda, New York.

BLACK AND BROWN ASH.

Table listing black and brown ash prices for Buffalo and Tonawanda, New York.

BIRCH.

Table listing birch prices for Buffalo and Tonawanda, New York.

ELM.

Table listing elm prices for Buffalo and Tonawanda, New York.

MAPLE.

Table listing maple prices for Buffalo and Tonawanda, New York.

BOSTON, MASS.

Table listing lumber prices for Boston, Massachusetts.

NEW BRUNSWICK CEDAR SHINGLES.

Table listing New Brunswick cedar shingle prices.

BRITISH COLUMBIA SHINGLES.

Table listing British Columbia shingle prices.

WOOD PULP ~ DEPARTMENT

EMBARGO ON PULP WOOD.

An embargo on the exportation of pulp wood from the Province of Quebec is one of the forthcoming events that is at present being seriously considered by the American paper and pulp manufacturers who make or use ground wood.

wood from Canada, the Paper Trade Journal says that the effect of the elimination of that source of supply can be imagined. A number of mills, it is stated, are wholly dependent on the supply of Canadian logs. What the owners of such mills would do under

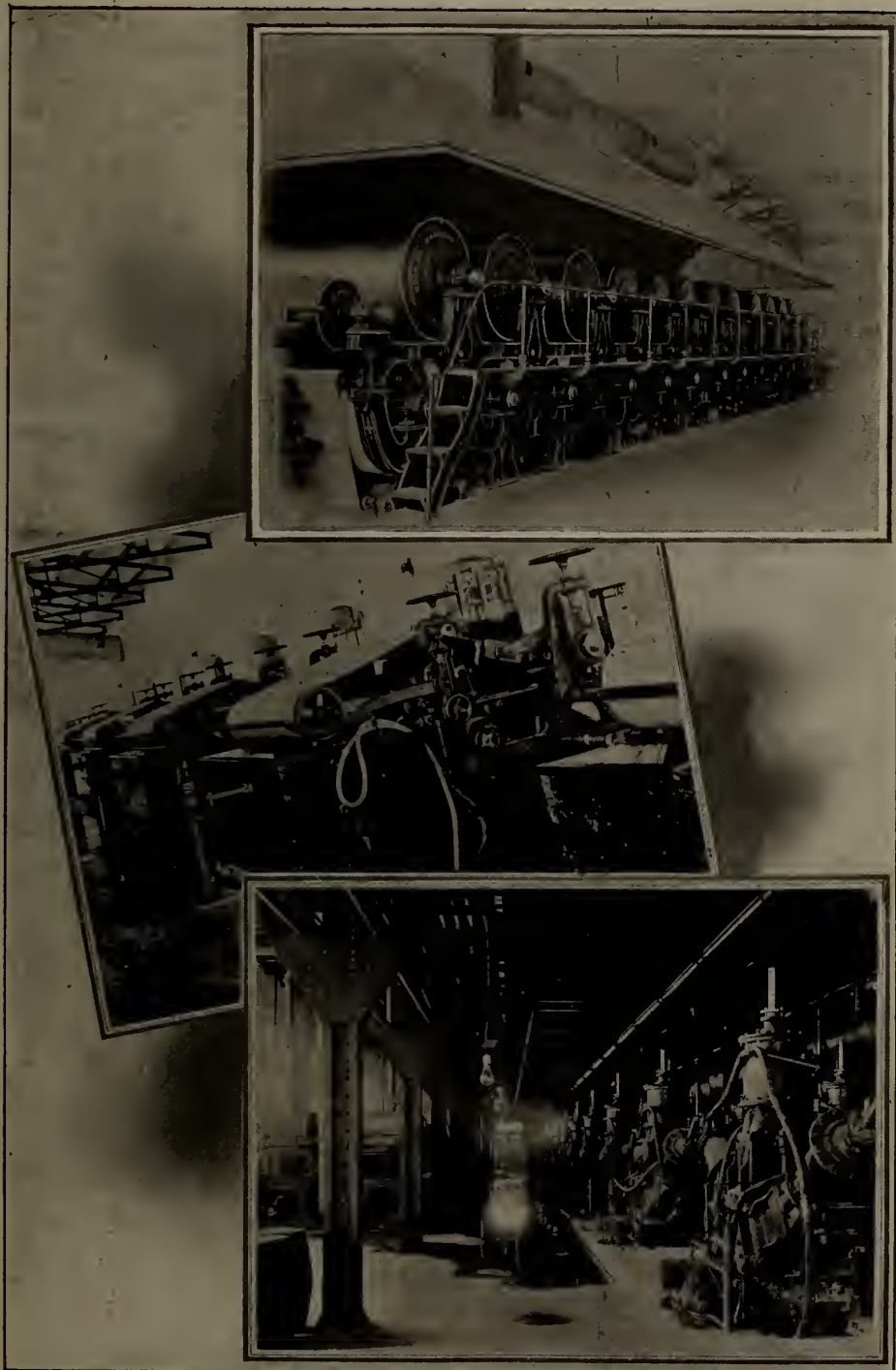

Top View, Paper Machine; Center View, Wet Pulp Machines; Bottom View, Wood Grinder.
VIEWS IN THE BELGO-CANADIAN PULP COMPANY'S MILLS, SHAWINIGAN FALLS, QUE.

So certain of the placing of the embargo are those interested that the matter, especially in the New York market, is looked upon as practically settled, the date of its imposition alone being open. The embargo, it is stated, will apply not only to wood cut on Crown lands but also to that cut on private lands.

As the paper mills in Northern New York especially get from 50 to 75 per cent. of their

the circumstances is difficult to predict. That pulp would cost considerably more there is said to be no question. With this increased cost there would, of course, be an advance in the price of all ground wood papers.

It is very problematical what policy will be decided upon in the event of a reorganization of the Government, and until some more definite announcement is made any prediction

must be largely a guess. This much is certain, that the feeling in Canada is strongly in favor of manufacturing the timber at home, and it would be no surprise if Quebec should follow the good example which has been set by Ontario.

UTILIZING SULPHITE MILL WASTE.

For some time J. S. Robeson, a chemist and inventor, has been experimenting at Ausable Forks, N. Y., with a new process for evaporating the waste liquor from the digesters of sulphite pulp mills, and finally a small plant was erected to make a practical demonstration. This plant is now in operation, and is taking care of 10 per cent. of the waste liquor of the mill. The result is said to be entirely satisfactory. The water is freed from all foreign substances, and emerges from the plant as clear as mountain spring water. All the pulp fibre and other substances are taken from it, and become a valuable product. This product is used for sizing paper, and is in great demand. It is also, by further treatment, hardened and made into cores for paper rolls. One hundred barrels of this material have already been produced, and the Rogers Company now sees the heretofore valueless refuse being turned into good dollars, and the obnoxious matter kept out of the Ausable River. Plans are already under way for the erection of a \$35,000 plant, which will be able to treat the entire waste liquor of the mill. The present plant is the property of a newly organized company, the American Glucose Company, of which Mr. Robeson is president. This company will erect the new plant.

PULP NOTES.

The Canada Paper Company, of Windsor Mills, Quebec, has established a new chemical fibre mill with a daily capacity of ten tons.

A new barking mill, giving initial employment to 100 men, has been built this winter by the Miramichi Pulp and Paper Company at Chatham, N. B. A stock of about 50,000 cords of pulp wood has been secured, which will keep the mill busy for some time.

The eighteenth annual general meeting of the shareholders of the E. B. Eddy Company was held at Hull early in March, when the statement was given out that the company has no intention of selling out to any syndicate, as recently reported. The original board of directors was again re-elected: Mr. E. B. Eddy, president; Mr. S. S. Cushman, vice-president, and Mr. W. H. Rowley, treasurer.

W. D. Woodruff, of Merriton, Ont., is interested in a new company formed to develop a fine water power on the Ottawa River. Associated with him are H. H. Dewart, Joseph Kilgour and Charles Mitchell, of Toronto. The lease which was granted the gentlemen gives them the right to develop a water power at Deux Rivieres for a period of ten years. The area of land granted, which includes part of the bed of the Ottawa River, covers 65 acres. The rights of lumbermen to float logs down the stream are reserved. For this lease the parties must pay a graded rental, which, after the fifth year, will be 25 cents per horse power. Engineer Andrew A. MacCallum has made surveys and plans of the water power development. He estimates that it will cost \$63,800 for 2,000 horse power and \$118,580 for 5,000 horse power. Mr. Woodruff says that the timber grants are extensive and include some excellent pulp wood.

C. H. VOGEL

A. M. Can. Soc. C. E.
OTTAWA, CAN. ENGINEER
Surveys, Plans, Specifications and Supervision
WATER POWER
Paper, Pulp and Sulphite Fibre Mills

THE Wood-Worker and Retailer

PRACTICAL FACTORY HINTS.

By ROB ROY.

It is the poorest of poor economy to let the stock of ordinary width of belting run out, or be too stingy about its use. The average widths in most establishments are 6 inches and under, and very much the largest part is 4 inches and under. These sizes should be kept in stock, for belting can be bought cheaper in quantities rather than a few feet at a time, and belts season or ripen and become better by being kept in stock. It is cheaper to take out a partly-worn belt and cut the poor places out of it, then relap and rivet. When a belt rips apart at the fastenings every day, and pieces are put in, the percentage of time lost amounts to quite an item in a month's work.

One of the best points about a circular saw, in fact about any kind of a saw, is to have the outer points of the teeth clean sharp. A majority of filers (this name is a misfit for lots of men that do file) think if they get the main part of the tooth up to an edge, that is all that is necessary. But this is only a part of what is required; the finishing touch is the most essential thing, and unless it is well done there is no certainty that any saw will do good work.

When the pile of waste is larger than the pile of good stock, you have got into the wrong pile of stock to cut from, unless the proprietor thinks it is cheaper to cut his stock into fire wood than into good stock. A pile of boards, with a view to economy, should have very few waste pieces in it. Sometimes practically all can be used to some part of the work. Many concerns buy cutting-up stock because they get it cheap, but stock that cuts to half waste should be bought for less than half price, as the cost of handling must be taken into the account. Waste makes high-priced fuel, and, if used with coal, generally burns up more coal than it makes fire. They should never be used at the same time.

When a band saw, cutting a board 8 inches wide, cuts in a curve of $\frac{3}{4}$ -inch in the width and spoils the board, it is time it was taken off and filed so the teeth will be of a length. A band saw, in resawing any width of stock, should cut straight through. Any deviation from a straight line shows that the teeth are longest on the concave side of the stock. A band sawyer of considerable experience was cutting 4x10 stock to make 2x10, and spoiled several pieces and broke several saws before he found out what the trouble was. He finally put in a new saw, which cut straight through. This led to an observation which showed him

that he had let the teeth get long on one side. The length of time that stock should remain in the steam box before drying should be learned by observation and study of conditions and the kind of wood to be steamed. I will give the way a concern largely interested in automobile work does its steaming. Wheel-rim stock of hickory, $2\frac{1}{2} \times 1\frac{1}{3}$, is steamed by exhaust steam five hours before bending. This stock never goes to the kiln. Spokes 2x3 and $3 \times 2\frac{1}{4}$, 22 inches long, lie in the steam box two whole days, and are left in the kiln a whole month before turning. Sawed wheel rims, 3x6 and 22 inches long, get the same treatment and are afterward oiled and piled up while waiting to be worked. Five-quarter whitewood for bending is steamed usually about five hours. This is never put in the kiln. Spoke stuff is put in the steam box helter-skelter.

Coal and wood for fuel to make steam with should be used separately, never at the same time. Coal is good enough, and wood is good enough, but when used together are not a good combination. The wood if possible should be used in the forenoon, for this reason: Usually it is necessary to keep steam up as far into the night as possible for dry-kilns and other purposes, and the coal fire does it. In the morning steam must be got up quickly for many purposes, and wood does it. It also gives a chance to clean the grates ready for the coal fire again in the afternoon.

The poorest place to keep tools of any kind is on the floor or up in some brace or on a beam. If laid upon the floor, they get into the shavings, and when you want them it costs more to hunt them up than they are worth. If you leave a tool in some brace or on some beam, you forget where you put it, and it is only found by accident, if ever it is found. The only way to keep tools is to have a place for each and cultivate a habit of keeping them there. A rule should always be kept in a handy pocket, unless you have a tool box on one side of the saw or fastened to the machine you are working on. Get the habit of keeping tools in a place for tools and, above all, don't forget where you put them.—The Woodworker.

Incorporation has been granted to McKeough & Trotter, Limited, Chatham, Ont., to manufacture saw mill and hoop and stave mill machinery, engines, boilers, etc. The capital stock is \$100,000 and the directors are S. Trotter, J. F. McKeough, S. M. Glenn, Robert Gray, N. H. Stevens, T. S. Holmes and M. Campbell.

HORSE-POWER OF WOODWORKING MACHINERY.

The following rule is given for determining the horse power required to run wood-working machinery of various kinds in a car shop planing mill:

Attach a steam engine indicator to your engine and take diagrams while running your shafting and loose pulleys only. Multiply the area of your engine piston by the mean effective pressure shown by these diagrams. Multiply the product so obtained by the number of feet the piston travels in a minute, and divide by 33,000. The quotient is the friction load of your engine, expressed in horse power. Now start up the machine or machines that you wish to test, leaving everything else just as it was before, and take more diagrams with the indicator. Ascertain the power developed under these conditions by the above rule, and from the result subtract the friction load. The remainder is the horse power required to run the machinery you mention. Take great care to have all conditions exactly the same in both cases, except that in one case the machines are idle, while in the other they are doing their regular work, as otherwise the result will be of no value.

MODERN BOX FACTORIES.

In looking over the modernized box factory we find manufacturers have changed their methods materially, says Barrel and Box. The old slip-shod way of delivering a truck load of lumber to the factory without keeping any track of it, and then making up such orders as may be in hand, has all passed. You see the foreman marching through the factory and watching every man who is handling lumber. He keeps his eye on the waste box. If he sees a piece that should not be there he wants to know the reason why. This is a necessity because lumber costs money nowadays. Labor is pretty high, too, and when you add these two items to your waste account and then figure on your general expenses and profits you will find that any shave in prices, and there may have been some shaves, means a loss of profit. The man who is satisfied to go on without improving his factory or operating on the improved method, which includes systematic handling of orders in the office as well, is liable to come out at the small end of the horn this year.

Brown & Company, Limited, St. Marys, Ont., have been incorporated, to carry on a lumber and wood-working business. The capital stock is \$40,000, and the provisional directors are George Brown, M. Tevlin, David Baird and T. J. Rundle.

AN IMPROVED MORTISING MACHINE.

The engraving herewith represents the Defiance Machine Company's No. 1 automatic vertical hollow chisel mortising machine, designed for cutting mortises in either soft or hard wood. It has been designed for the use of manufacturers of wagons, agricultural implements, railway car, ship builders and various other woodworkers. The principle involved is the use of an auger revolving within a square hollow chisel attached to a vertically moving ram which is fed down to the work, a single movement produces a clean square mortise, corresponding to the exact size of the tools used. By moving the table horizontally and at right angles with a single auger and chisel, mortises of various widths and lengths can be cut, although one each $\frac{3}{8}$ ", $\frac{3}{4}$ ", $\frac{7}{8}$ ", and 1" augers and chisels are furnished with each machine.

This machine contains many new patented improvements. All the working parts are outside of the frame in plain view and easy of access, which is a most desirable feature. The ram has a quick return and it is balanced in any position without the use of weight or spring, and is entirely noiseless in its operation. The table is provided with a system of stops and gauges for laying off the work.

The frame is a massive casting in one piece, with cored centre and a broad base. It is original in design

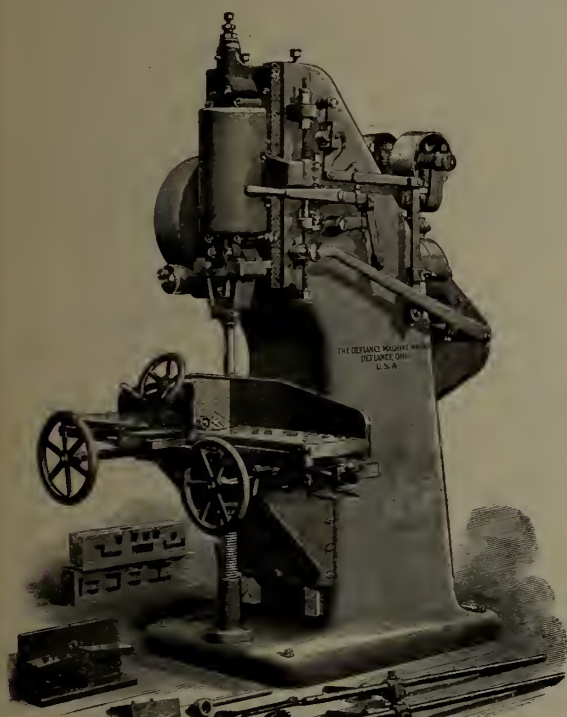

No. 1 Automatic Vertical Hollow Chisel Mortising Machine.

Export Shipping Weight, 5,100 Pounds.
Net Weight, 4,300 Pounds.
Cubic Measurement, 175 Feet.
Cable Word, MINERA.

and of sufficient strength to do the very heaviest class of mortising with ease. The ram to which the auger and chisel are attached is thoroughly gibbed to the frame in planed and scraped angle ways, and is reciprocated vertically by means of a heavy worm gear and a screw running in a reservoir of oil and driven by a double friction clutch. The auger spindle extending up through the centre runs in self-lubricated bearings. The top end rotates against an adjustable bronze screw to support the end thrust, and it is also self-lubricating. The pulleys for driving the auger spindle are so constructed to automatically maintain the proper tension to the belt at all times. The ram has a stroke up to 10" and its position is controlled by a convenient hand lever, a slight movement of which instantly starts or stops the feed or reverses it at any point. The depth of the mortise can be changed instantly while the machine is in motion, by means of a screw adjustment. It has four rates of feed with a quick return motion, enabling the machine to cut mortises in either hard or soft wood as large as 2" square at a single stroke.

The compound table is thoroughly gibbed to the front of the frame, and it is supported upon a heavy steel screw, operated by a convenient hand wheel for raising and lowering the table. To the table patent stops with a micrometer adjustment are fitted to facilitate the duplication of mortises, and they can be instantly lifted up out of the way and the table moved in

either a longitudinal or lateral direction and returned to its original position without destroying any of the adjustments. A chuck is furnished for angle mortising and it is laid off to 20°. Gauges are also supplied for gauging from the end of the work or from a mortise. A powerful adjustable clamp is fitted to the table for holding the work. It will accommodate stock 12" by 15" square and the machine will cut mortises in any position in a piece of timber of this size or any size under.

The floor space occupied is 48" by 70", and two horse power are required to drive the machine.

The Defiance Machine Works, Defiance, Ohio, will be pleased to furnish further particulars on application.

SHAVINGS.

The Christie Woodworking Company, St. John, N. B., have purchased additional property and intend increasing their plant.

A decided preference is shown in Canada in favor of barrels for the shipment of apples. The large dealers all prefer barrels to boxes in packing or shipping apples. On the contrary the small dealers favor the box, owing to the fact that they find a more ready sale for this kind of package. There is rarely a surplus supply of apples in barrels in this country, but if the box was adopted, the dealers say, it would be quite different. This question has been much discussed lately, a large percentage giving the barrel preference.

The Conger Lumber Company, of Parry Sound, Ont., have built a new stave mill at Moon River Bay, on the shores of the Georgian Bay. The mill is covered with galvanized roofing and has a cutting capacity of 40,000 staves per day with the machinery already installed. There is ample room to double the output and the boiler and engine were selected with that end in view. Most of the timber used will be taken from the Company's limits and will be rafted down Six Mile Lake to the mill. For this purpose the company is building a fine new boat to be called the Admiral Togo.

QUEBEC TIMBER LIMIT HOLDERS' ASSOCIATION.

The annual meeting of the Province of Quebec Limit Holders' Association was held at the Chateau Frontenac, Quebec, on March 8th, at which F. P. Buck, Esq., Vice-President, presided. The following firms were represented:

Arthabaska W. & P. Co., Henry Atkinson, Bennett & Co., Chaleur Bay Mills, Chicoutimj Pulp Co., H. Calvin, Est. Frank Dudley, W. C. Edwards Co., F. F. Farmer, D. Frasér & Son, Fenderson & Co., Goodday & Co., Gillies Bros. & Co., Great Northern Lumber Co., Jonquiere Pulp Co., Laurentide Paper Co., Lake Megantic Pulp Co., Price Bros. Co., J. Richardson & Co., Wm. Power, River Ouelle Pulp & Lumber Co., Riordan Paper Co., Royal Paper Mills Co., Saguenay Lumber Co., St. Maurice Lumber Co., Tourville Lumber Mills Co., Union Bag & Paper Co., Pentecost Pulp Co., Mossom Boyd and E. A. Dubuc.

After reading the minutes of last meeting, the annual report and financial statements were read and adopted. The election of officers followed and resulted as follows:

President—Hon. W. C. Edwards.

Vice-Presidents—F. P. Buck and W. Price.

Executive Committee—Rod. Tourville, Alex. McLaurin, Wm. Power, M. P., H. W. Durant, Archibald Fraser, J. W. Breakey, F. F. Farmer, E. A. Dubuc, John Champoux, H. K. Egan, G. Starnes.

Secretary-Treasurer—Paul G. Owen.

The meeting closed with a vote of thanks to the officers for the past year, and to F. P. Buck for acting as chairman of the meeting.

JOTTINGS BY THE WAY

Dr. R. W. Bell, Inspector of the Ontario Boards of Health, recently returned to Toronto from a six-weeks' tour of the lumber, mining and railway construction camps of New Ontario. He found, on the whole, that the employers were carrying out the regulations in regard to sanitary arrangements, and were quite willing to adopt any suggestions. When he left for Toronto there was only one case of smallpox, and that was at the farthest point reached by the Temiskaming & Northern Ontario Railway. All precautions had been taken, however, and there was no danger from this source. Cases in several other camps had recovered. The greatest difficulty in regard to sanitary regulations was found in railway construction camps, owing to the manner in which the gangs divided into little camps along the lines.

"Greater quantities of balsam have been cut the past winter than ever before in one season," said a lumberman from the north the other day. "The price of white pine is now so high," he continued, "that people are looking around for substitutes, and this promises to result in a larger consumption of such woods as spruce, hemlock and balsam. Of course, there is no wood quite so good as pine for some purposes, but it means a lot of money to buy even the lower grades, and often a saving can be made by substituting hemlock or balsam. Balsam can be sold at \$13 mill run and give the manufacturer a fair profit, for there is absolutely no waste, whereas with pine about 25 per cent. of the log is not marketable." This gentleman spoke of the vast quantities of balsam to be found in Northern Ontario, and his statement can be confirmed by reference to the reports made to the Crown lands Department by surveyors.

Indianapolis is the largest veneer manufacturing centre in the world. There are seven factories in that city, and their combined output is nearly equal to that of all the other factories in the United States. There are two kinds of veneering—sawed and sliced—but it takes an expert to tell the difference. The process of manufacture is simple. The logs, delivered at the factory in the rough, about 13 ft. in length, are first cooked in hot water vats to make them soft and workable. After being thoroughly cooked they are placed on machines and either sliced by a powerful knife the length of the log or cut by a circular saw into slabs about one-twentieth of an inch thick. These slabs are the full length of the log, and when first cut are so pliable that they can be bent double without breaking. The uniform thickness or thinness of the slabs is preserved by the action of the machinery, and does not vary as much as a hair's breath in the entire length of the slab. After the slabs are sliced or sawed, they are seasoned by steaming. This requires only about 24 hours, and then they are ready for the market.

THE NEWS

ONTARIO.

—The dissolution is announced of Kernohan & Ferguson, lumber dealers, London, Ont.

—The portable saw mill of McBurney & Sons, operating near North Bay, Ont., was destroyed by fire last month.

—The Birch Saw Lumber Company, of Banbury, Ont., have secured a large number of logs and are looking forward to an active season.

—David MacLaren, the well known Ottawa lumberman, has donated \$5,000 towards the endowment fund of Queens University, Kingston, Ont.

—George Bushfield, of St. Thomas, Ont., has been appointed manager of the factory department of the Muskoka Wood Company, Huntsville, Ont.

—A. D. McConnell and Thomas Reid are building a new mill at Sand Creek, Ont., the machinery for which has been purchased from W. S. Greensides.

—The business of the Algoma Settlers Lumber Company at Chapleau, Ont., has been taken over and is being continued by the Mageau LeBlanc Lumber Company, Limited.

—The Rider & Kitchener saw mill at Lindsay, Ont., has been refitted by David Gage, the well-known millwright, and will this season be in charge of Robert Armstrong as foreman.

—The Parry Sound Lumber Company have sold the steamer "Seguin" to the Dominion Government. It will be fitted out and used by the Marine Department as a supply boat for lighthouse service.

—S. Running is applying to the Town Council of Gananoque, Ont., for a free site on which to build a saw mill and box factory, to be 25x70 feet and 30x50 feet respectively, both two stories high.

—The business of the late John Hillock, lumber dealer, Toronto, has been converted into a joint stock company, to be known as John Hillock & Company, Limited. The capital is placed at \$40,000.

—Sims Bros. are installing new machinery in their mill at Massey, Ont., when they will be in a position to turn out about 25,000 feet of lumber per day. They may install an electric plant to light the mill and the village streets.

—The Blonde Lumber Company, Chatham, Ont., recently elected the following officers: President, William Ball; vice-president, N. H. Stevens; manager, B. Blonde; assistant manager, Jacob Blonde; secretary-treasurer, T. Doyle.

—The Eagle Lake Lumber Company, New Hamburg, Ont., has been dissolved, but I. M. Clemes, who was interested in the company, is building a new saw mill at New Hamburg and has secured a good stock of logs for the coming season.

Morris S. M. Long, wholesale lumberman, Spec-

tator Building, Hamilton, has taken his brother, Guy H. Long, into partnership. G. H. Long will look after the outside trade and the firm will be known in future as The Long Lumber Company of Hamilton, Ontario.

—George B. Miller, of Parry Sound, Ont., has invented and patented an improved adjustable gang for sawing lumber. He claims that it will save \$12 per day in labor, 20 per cent. in steam, and a considerable sum in the cost of a mill. It will resaw slabs in any desired thickness and is said to give from 8 to 12 feet more per log than a band mill or circular. It dispenses with the steam kicker, steam loader, steam nigger and steam feed and is specially valuable for the manufacture of small logs.

THE EASTERN PROVINCES.

—Meunier & Francoeur, sash and door factory, Montreal, have dissolved.

—The annual meeting of the St. John River Log Driving Company will be held at Fredericton, N. B., on April 5th.

—J. D. Sowerby & Company, of Oak Bay, Que., whose saw mill was recently destroyed by fire, are preparing to rebuild this spring.

—Extensive improvements are being made to Stetson, Cutler & Company's mill at St. John, N. B., which is expected to resume operations for the season early this month.

—Donald Fraser & Sons, of Fredericton, N. B., have finished work on their large new shingle mill at the mouth of Baker Brook. They intend to build a large saw mill there early in the spring.

—The Restigouche Lumber Company has been organized to operate a large wood-working factory at Dalhousie, N. B. The Robb Engineering Company, of Amherst, N. S., have received the order for the steam plant.

—The Madawaska Log Driving Company held their annual meeting at Fort Kent, Maine, recently, when the following directors were elected: President, W. H. Cunliffe; secretary, G. V. Cunliffe; directors, Neil McLean, A. W. Brown, John Kilburn and Charles Miller.

—The York & Sunbury Manufacturing Company, Limited, Gibson, N. B., has been incorporated, to carry on a general lumbering and woodworking business. The capital stock is \$32,000, and the promoters include Walter Limerick, James F. McMurray and A. J. Gregory, of Fredericton, William H. Murray, of St. John, and Frederick Pond, of Gibson.

—H. W. Shaw and John E. Allan, of Hawkshaw, George S. Inghram, of Southampton, A. I. Fox, of Canterbury Station, and A. Grant, of Shogomoc, have been incorporated as the Skif Lake Manufacturing Company, Limited, to carry on a general lumber business. The capital is \$25,000 and the chief place of business is to be at Canterbury Station, N. B.

—A. R. Tibbits is organizing the Canada Lumber,

Manufacturing & Transportation Company, which will be an amalgamation of the business of George D. Prescott and the Aptus Veneer Company, Albert, N. B. It is proposed to capitalize the new company at \$200,000. I. C. Prescott will take full charge of the company's business in the woods, while George Prescott will give his attention to the manufacturing department.

—The annual meeting of Rhodes, Curry and Company, woodworkers and manufacturers, Amherst, N. S., was held on March 1st last. The reports presented showed that the past year had been very successful. The volume of business was \$2,300,000. There were built during the year 1,600 cars, and the outlook for the present year was stated to be most encouraging. The vacancy on the board of directors caused by the death of the late J. M. Townsend, K.C., was filled by the appointment of J. R. Douglas, and in addition Senator Mitchell, of Drummondville, and B. F. Pearson, M.P.P., of Halifax, were added to the board. The following officers were re-elected: President, N. Curry; vice-president, N. A. Rhodes; secretary-treasurer, J. M. Curry; solicitor, E. N. Rhodes.

—The Bangor News says that Aroostook lumbermen are working for the repeal of the Act of Congress which permits forest products cut in Maine, driven down the St. John river to Fredericton and St. John, and there manufactured, to be admitted to the United States free of duty, providing the said products are owned by American citizens. They claim that the occasion for such legislation no longer exists. Previous to the passage of the Act, Aroostook county had no outlet over American soil for its forests or other products, but now there is a direct outlet and it is claimed that the law should be at once repealed and the lumber manufactured at home instead of being diverted to foreign territory. The quantity of lumber involved is upwards of 75,000,000 feet annually.

MANITOBA AND THE TERRITORIES.

—Mayor Ulyot, of Manitou, Man., has sold his planing mill to Magee & Sons.

—The Great Northern Lumber Company, Limited, Humboldt, N. W. T., has been incorporated.

—The Arrow River Lumber Company have purchased W. S. Burley's lumber business at Neepawa, Man.

—New machinery has been installed in the saw mill of the Northern Lumber Company at Dauphin, Man.

—A. C. Adamson & Company, Elbow, N. W. T., have commenced business as lumber and implement dealers.

—Brown & Rutherford, of Winnipeg, are supplying 560 window frames for the Eaton departmental store building in that city.

—The Weyburn Lumber & Elevator Company have purchased the Soo Line mills at Weyburn, N. W. T. from A. R. Leitch & Company.

—Charles Manning is building a saw and planing mill at Cartwright, Man., which will include two circular saws, hand saw, mortising machine, planer and turning lathe.

CRAIG MINE CRYSTAL CORUNDUM WHEELS

Our Pure Crystal Corundum Saw Gummars have no equal for their Rapid, Cool, Cutting Properties.

Read the following from Bulletin 180 of the United States Geological Survey, which says:

"Often a distinction is made between emery and corundum, many persons not recognizing emery as a variety of corundum.

Emery is a mechanical admixture of corundum and magnetite or hematite. It is, of course, the presence of corundum in the emery that gives to it its abrasive qualities and makes it of commercial value, and the abrasive efficiency of emeries varies according to the percentage of corundum they contain."

Emery is imported, mined by Greeks and Turks and contains only about 25% corundum. Our Crystal Corundum is guaranteed to be 98% pure alumina, a Canadian product, mined and manufactured by Canadians for Canadians.

HART CORUNDUM WHEEL COMPANY, Limited, Hamilton, Ont, Can-



BRITISH COLUMBIA.

—Ross Bros., lumber merchants, Whitemouth, Man., are removing to British Columbia.

—Mackinnon, Ferguson & Company, dealers in timber limits, etc., Vancouver, B.C., have dissolved partnership.

—The Elk Lumber & Manufacturing Company, of Fernie, B. C., recently cut a tree which produced 7,032 feet of lumber.

—The Robinson-McKenzie Lumber Company, Cranbrook, B. C., have installed a new planer and matcher weighing 16,500 pounds.

—E.H. Herps & Company, of Vancouver, B.C., are rebuilding the dry kilns at the Ruskin mill, which was destroyed by fire last month.

—The Yale-Columbia Lumber Company, Nakusp, B. C., have given notice of their intention to improve the Mosquito Creek for logging purposes.

—The name of the Cranbrook Sash & Door Company, Limited, Cranbrook, B.C., has been changed to the Kimberly Milling & Manufacturing Company.

—The Bowman Lumber Company, Limited, was incorporated by the British Columbia Government on March 4th, with a capital stock of \$1,000,000.

—The new mill of the Canadian Pacific Lumber Company at Port Moody, B. C., sawed its first log on February 28th last, everything working very satisfactorily.

—A Mr. Paterson, who has conducted lumbering operations in the state of Maine, has taken over the saw mill at Sydney, B.C., and is now making improvements with a view to operating it.

—The International Timber Company has been registered as an extra-provincial company in British Columbia, with a capital of \$500,000. The head office will be at Victoria, C. A. Holland being their attorney.

—The Moyie Lumber and Milling Company, Moyie, B.C., are offering their timber limits and saw mill property for sale. To the party looking for a large proposition, the property of this company is worth consideration.

—The capitalists who a few months ago acquired large timber locations bordering on Kennedy Lake, west coast of Vancouver Island, B. C., have decided to build a large saw mill this summer. The mill will engage solely in export trade.

—The City Council of New Westminster, B.C., have finally granted a lease of Dock square to the Small & Bucklin Company for the purpose of building a saw mill. The lease is for 35 years, with privilege of renewal at a rental of \$300 a year.

—Nothing has yet been done regarding the proposal to erect a saw mill at Esquimalt, B.C. There is a scheme on foot, but the promoters say that the plans have not yet matured. The place is considered by many to be one of the best sites in British Columbia for a saw mill.

—A surveying party acting under directions of Gore & McGregor, of Victoria, B. C., are said to be

making surveys of Powell river in connection with a pulp concession held by a Victoria syndicate. It is proposed to build a large pulp mill on the shore near the mouth of the river.

—The Victoria Lumber & Manufacturing Company have just completed an extensive waterworks system for their mill at Chemainus, B.C. A 10-inch main has been laid from Fuller's Lake to the mill, with 4-inch mains throughout the lumber yard, standard hydrants being placed at regular intervals. The system cost \$10,000 and the pipe was supplied by the Canadian Pipe Company, of Vancouver.

PREMIER TWEEDIE ON LUMBER.

Premier Tweedie, of New Brunswick, in his budget speech on March 21st, referred to the lumber business in the following words:

“During the past year the condition of the province has been fairly prosperous, although there has been a depression in the lumber industry. The depression cast a gloom over the operators, for they feared that it was likely to last a long time. Unfortunately, it came at a time when a change had been made in the rate of stumpage.

“This House is aware that for many years the rate for spruce was \$1 a thousand and the mileage \$8 a mile, with the right to renew each year for \$4

After the twenty-five years system of leases was adopted a great many persons obtained land at upset price of \$8, which in a few years became extremely valuable, for the price of lumber kept going up until it reached its highest point about three years ago. At that time our operators made a great deal of money. The government noting with satisfaction the improvement of the lumber industry did not immediately raise the rate of stumpage, because they considered that the lumbermen had suffered losses and they wished to give them a chance to recoup themselves. But after a time it became evident that a change in stumpage should be made so that a larger revenue might be derived from that great industry.

“When the depression came efforts were made by the lumbermen to have the stumpage reduced. It was argued that that trade could not stand the increased rates. But the government considered that the lumbermen had been making a great deal of money for several years and that the lands they had leased had increased immensely in value. Therefore they thought that it would not be in the interests of the province to accede to their wishes. Besides, we were able to show that the depression was only temporary, and I am happy to say that the cloud has passed away and that now our lumber industry is in a fairly prosperous condition.

“One result of the increase has been that our territorial revenue was larger last year than ever before, reaching the large sum of \$296,424. There is, therefore, no reason to doubt the value of the timber lands of the province, nor is there any reason for saying that we are oppressing this industry.

“Some people have affirmed that the policy of the

Quebec government is more favorable to the lumbermen than ours, but those who have lumbered in both provinces and who have a right to know, prefer the conditions that exist in New Brunswick. The great increase that has taken place in our territorial revenue shows that we have in our lumber lands an asset of great value, and that is one of the reasons why our credit is the best of any province in Canada.

“If we were willing to sell our lumber lands outright they would bring in a sum sufficient to pay off our entire debts and leave a surplus so large that it would give us almost as much revenue as the sum we now derive from these lands. But this government would never consent to adopt such a policy as that which would place our lumber lands in the hands of some great monopoly. Possessing such an asset in these lands is a sufficient answer to those who accuse us of having added to the bonded debt of the province.”

METHODS OF QUARTER-SAWING.

A correspondent of The Woodworker gives what he considers the most practical methods of quarter-sawing.

Fig. 1 represents the diameter of whole log, showing where first line should be run. Fig. 2 shows half of log where second line is run, while Fig. 3 shows one quar-

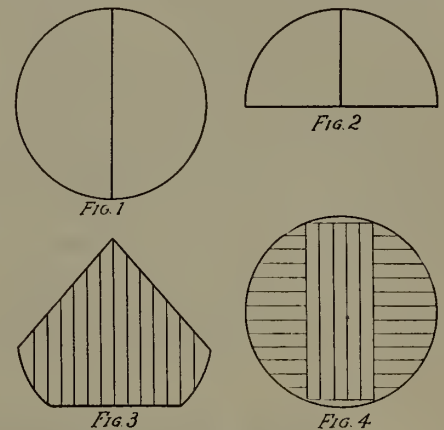

ter with back taken off to give bearing on headblock, and method of sawing.

Duplex dogs are a great help in quarter-sawing, but a little practice will enable a practical man to do the work with the ordinary Knight or similar dogs.

Fig. 4 represents another method much used in some localities, especially on logs of small diameter, but for large logs, say 24 inches and up, I prefer the first method for best results. In either case you must have some sort of edger for finishing up the hoards.

CALIFORNIA EXCURSION.

The Chicago, Union Pacific and Nyrth Western line runs through first-class pullman and tourist sleeping cars to points in California and Oregon. Personally conducted excursions from Chicago every week. Lowest rates, choice of routes. Finest scenery. Special attention given to family parties. For maps, illustrated folders and rates, address B. H. Bennett, general agent, 2 King street, Toronto, Ont.

The Hanchett Adjustable Saw Swage

For large and small Circulares, Bands, Band Resaw, and Gang Saws.

FILERS MILLMEN

A TRIAL WILL COST YOU NOTHING. We send you these tools for you to use for 30 days, free. If you then feel that you can afford to do without them you are to return them at our expense. They save Time—Files—Labor—Saws. Adjustments are perfect. Construction simple. Workmanship the best. They have stood the test. You run no risk when you purchase a Hanchett Saw Swage. They are standard make.

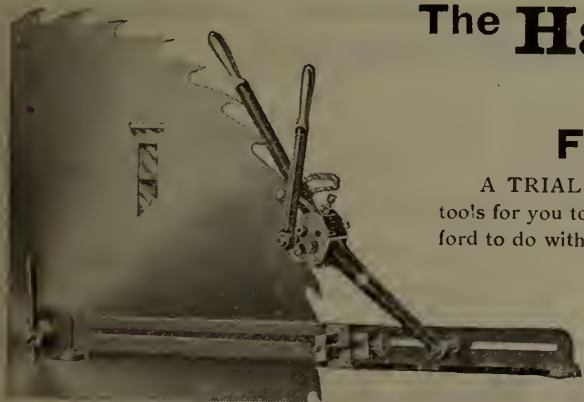

Hanchett Circular Saw Swage with Bench Attachment

Write for circular to—

HANCHETT SWAGE WORKS,

Big Rapids,

Mich., U. S. A.

WE MAKE SWAGE SHAPERS.

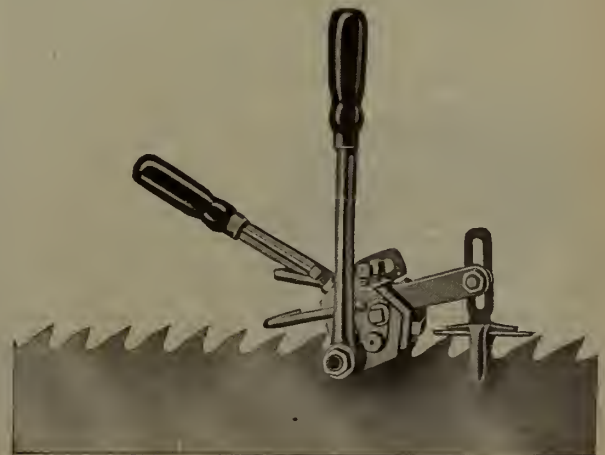

Hanchett Band Saw Swage

FORESTRY DEPARTMENT

PROPOSED FORESTRY CONFERENCE.

The suggestion of Sir Wilfrid Laurier transmitted by Hon. W. C. Edwards to the Canadian Forestry Association while in session at Ottawa last month, to the effect that a forestry conference be held in Ottawa during the coming summer or fall, is regarded as a very significant recognition of the progress which is being made by the forestry movement, as well as of the importance and usefulness of the Canadian Forestry Association. We trust such a conference will be arranged and bespeak for it marked success.

THE FOREST AS A NATURAL RESOURCE.

Dr. Judson F. Clark, Provincial Forester, gave a most interesting address on "The Forest as a Natural Resource" before the National Science Club of the University of Toronto on Tuesday afternoon, March 7th. He made a strong and convincing plea for the public ownership and control in perpetuity of Canada's forest domain and showed not only the importance but the necessity of preserving intact the forest wealth of the country instead of allowing it to be dissipated by private exploitation regardless of consequent disastrous results on climate, soil, water powers, and on the permanency of natural timber resources. The

effect of totally denuding certain districts, owing to unscientific methods of lumbering, was illustrated by various views. The burning and disposal of the debris after the trees were cut, said Dr. Clark, was perhaps the greatest problem confronting forestry in Canada. He believed that a fire through a forest, provided enough large trees were left to prevent the total destruction of the growth, resulted beneficially, in that it prepared the soil for new seed and got rid of the dangerous debris. The provincial system of fire-rangin, he declared, was the best in the world.

Greece, Mesopotamia, Sicily, and other countries, he said, formerly rich agricultural lands had become comparatively unproductive simply because they had allowed their forest lands, to be denuded. The same conditions were now applying to a lesser extent to the great Mississippi Valley. Canada had the richest forest domain in the world, and provided proper Government action were taken now to preserve it for all time, the revenues of this country from its timber resources would be simply inestimable. Better, he urged, that the revenues from this source should go into the public treasury than to create multi-millionaires.

AN EARLY EXPERIMENT IN FORESTRY.

An interesting example of the profit of conservative forest management is furnished by Dr. S. B. Caldwell, of Paducah, Ky., who has

dealt in timber lands in the southwestern part of the State for fifty-eight years. "In 1847," says Dr. Caldwell, "I sold timber from a tract of land at \$1 an acre, the purchaser having the privilege of removing what he wanted and leaving what he did not want. He took the choice trees, but left a considerable amount standing. In 1870 I sold the timber from the same tract and got for it \$2 a tree. The purchaser removed an average of three trees per acre. In 1884 I sold the timber from the same tract for the third time, and got for it as much as I had received at the second sale.

Dr. Caldwell's experience in the woods taught him long ago the wisdom of conservative forest management. Thirty years ago, when he came into possession of a tract about 700 acres near Paducah, he sold a quantity of timber for wagon stock. At that time forestry in that country was virtually unknown. Dr. Caldwell, however, was sufficiently foresighted to allow no trees to be cut except those which he selected. He went about in the woods and picked out trees whose tops and general appearance showed they had passed their period of greatest vigor, and trees which interfered with promising young growth. His forest has been culled a number of times in the past thirty years, but so wisely has the cutting been done that to-day the land will average from 10,000 to 15,000 board feet per acre. This was an experience in forestry which has amply justified itself, and shows how a shrewd, far-sighted man may, even without technical advice, secure good returns from his woodland without impairing its productive value and while putting himself in position to profit by the steady rise which is taking place in timber values.

WE RECOMMEND FOR

Saw Mill, Planing Mill and all Classes Wood-Working Machinery

ALUMINUM GENUINE BABBITT AND MANGANESE ANTI-FRICTION BABBITT METALS

OUR name and trade mark the shield on every bar. We guarantee these two brands to wear considerably longer than any other make. Our Babbitt has been used by largest users for a good many years. If you have never used Syracuse Babbitt we shall be pleased to receive sample order. The best is none too good for the users.

MADE IN CANADA BY CANADIANS AND FOR CANADIANS

SYRACUSE SMELTING WORKS,

CANADIAN FACTORY: MONTREAL

Please mention this paper when corresponding with advertisers.



Sole Canadian Agents
WATEROUS, BRANTFORD, CANADA

Prices Reduced



If you have not seen a sample of our "Patent" Legging—make a point of seeing one. The best thing out in Leggings. Just the thing for Lumbermen and Prospectors

Write us for description and prices

The R. M. Beal Leather Co.
LIMITED
LINDSAY, ONT.

SPRING brings with its increased business increased demands for insurance. That means an expenditure which any lumberman is glad to cut down provided he can at the same time have his interests guarded securely. ¶The thing can be done. We are doing it every day for lumbermen all over Canada and the United States, and doing it in a way which, judging by our increasing patronage, is wholly satisfactory to them. ¶We can take large lines, and protect ourselves by reinsuring in our allied companies, the Lumber Underwriters of New York and the Toledo Fire and Marine Insurance Company of Sandusky, Ohio. That will save you the clerical labor and worry attendant upon apportioning your insurance in small amounts among a dozen companies.

LUMBER INSURANCE COMPANY OF NEW YORK
66 BROADWAY, NEW YORK

FOR THE CAMP

We have a very suitable lot of goods for camp supplies. We make this kind of trade a specialty. You who are not getting suited just as well as you would like, try us for your next order, and give us a chance to demonstrate our ability to give you satisfaction in this very important department of your business.

H. P. ECKARDT & CO.

Wholesale Grocers

TORONTO

THE MANITOBA IRON WORKS.

The Manitoba Iron Works, Limited, of Winnipeg, one of the newest of the many new business enterprises in the West, is a most striking example of the rapidity of western industrial development. The company was organized in March, 1903, to carry on a general foundry and machine business, and in August of the same year operations were commenced in shops affording a floor space of approximately 25,000 square feet. Since that date these shops have been in continuous operation with an ever increasing staff numbering now over 100 mechanics and helpers. The buildings are solid red brick throughout and present an exceptionally good appearance from Logan avenue frontage. A siding tributary to the C. P. R. runs full length of their property, affording accommodation for 20 cars, and incoming and outgoing shipments are handled direct to and from the shops or warehouse.

There are seven buildings grouped about the pro-

punch and shear to punch $\frac{3}{4}$ inch hole in plate $\frac{3}{4}$ inch thick; air tools for riveting and calking boilers and tanks. The power house has a 75 horse power Brown tandem compound engine, Cookson heater and purifier, Rand air compressor, and the other necessary fittings. Lavatories for the shopmen adjoin the boiler room, and are conveniently fitted up.

A special effort is made to cater to the saw-mill trade, a full line of sprocket chain, shafting, frictions, babbit metal, etc., being carried, in addition to a complete list of patterns for saw-mill castings. The superintendents have had considerable experience in saw-mill work and orders are handled intelligently and carefully. During the past eighteen months they have furnished new equipment for all the large mills of Manitoba and Western Ontario, including several boilers, notably one 84" diameter and 18 feet in length to the Rat Portage Lumber Company for their Norwood mill. This was the largest boiler ever built in Western Canada. The

OBITUARY.

The death took place last month of Edward Walker, who conducted a general store and lumber business at Bass River, N.B.

Mr. William H. Parsons died of pneumonia at Palm Beach, Florida, last month. Mr. Parsons was largely interested in the company which recently purchased the valuable timber property of C. M. Bostwick & Company at Great Salmon River, N.B.

Word has been received of the death, in New York, of Mr. Alexander Begg, who was one of the oldest newspaper men of Canada and well known by his connection with several large schemes for emigration from Great Britain to this country. Mr. Begg was the founder of the CANADA LUMBERMAN and in 1894 published a history of British Columbia.

Late correspondence from across the Atlantic brings the news of the death of Mr. Ernest G. Leary, of the firm

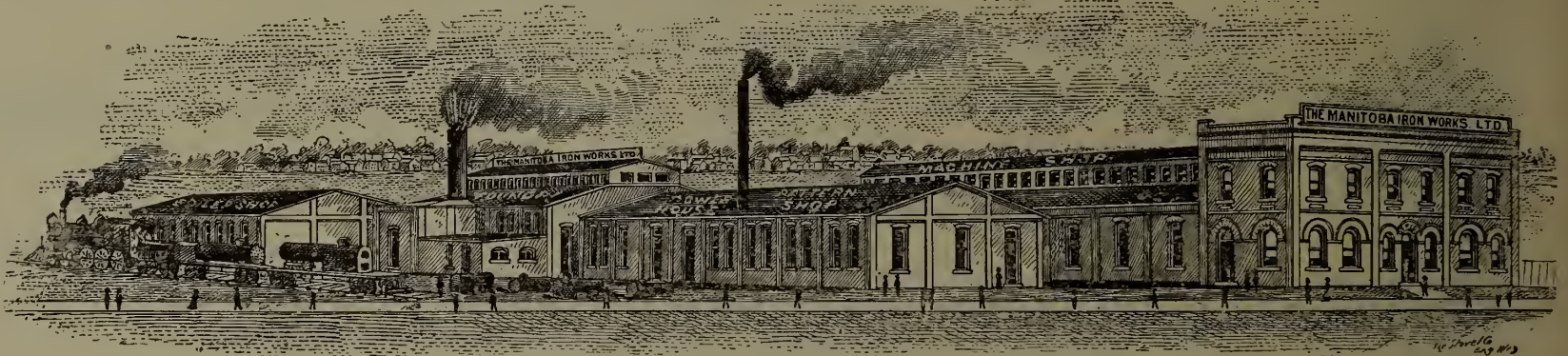

WORKS AND OFFICES OF THE MANITOBA IRON WORKS COMPANY, WINNIPEG, MAN.

erty. The first is a machine shop 60x125 and two storeys high; on the second floor are the general offices, occupying a space of 60x24, handsomely fitted in hard wood and fine brick vaults; beneath the offices is the general shipping room, and the balance of the building, which is splendidly lighted and ventilated, is a machine shop. On this floor are to be found an iron planer 50x60 inches and a 34 foot lathe that was specially made for the company at Galt, Ont., also a travelling crane of great strength and capacity for carrying machinery from one part of the building to another. The full equipment, comprising as it does ten lathes, upright and radial drills, pulleys, turning and key-seating machines, shapers, planers, millers, grinders, etc., is most complete and capable of handling the heaviest work.

Next comes the pattern shop, that most important part of every foundry. This building is 30x40 and very fully equipped. The forging shop is 40x80 and carries an 800 lb. steam hammer and a large bolt-forging and upsetting machine with three double threading machines. The foundry has a moulding floor 60x80, a crane of five tons capacity, and is equipped with a Whiting cupola with a capacity of five tons of molten metal per hour. Off the moulding room proper are the core ovens, chipping and cupola rooms.

The boiler room is 40x60 and is equipped with plate roller to roll sheets $\frac{3}{4}$ inch thick and 10 $\frac{1}{2}$ feet wide;

forge shop is particularly well equipped with heavy bolt-forging and threading machines, steam hammer, etc., and is kept running at full capacity all the time.

The other lines manufactured by the Manitoba Iron Works are elevator machinery, hoilers and engines, steam pumps, heaters, mill machinery and castings. They have agencies for Cookson heaters and purifiers, sprocket chain and grain handling machines, Eureka cleaning-machinery, Foos gasoline-engines, air-compressors, rock drills, brass goods, belting, wood pulleys and general supplies of all kinds.

The company was organized by Messrs. T. R. Deacon, H. B. Lyall, J. A. Coulter and R. Murray, to take over the business and plant of the Standard Machine Works, Winnipeg, and the Rat Portage Iron Works at Rat Portage, owned respectively by Coulter & Lyall and Robt. Murray. The officers of the company are: President, T. R. Deacon, C.E., M.E.; Vice-President, J.A. Coulter; and Secretary-Treasurer, H. B. Lyall.

VALUES THE PAPER.

Mr. Thomas Elston, manufacturer of hardwood lumber and barrel heading, Centralia, Ont., in renewing his subscription to THE LUMBERMAN, says: "I must say I value your paper a good deal. Although I do a small lumber business, it has been a great help to me."

of C. Leary & Company, timber brokers, London, England. Deceased was forty-eight years of age and joined the firm of C. Leary & Company about fifteen years ago. He had a very successful commercial career, during which he made many trips to America.

The Ontario Crown Lands Department was recently notified of the death of an esteemed officer in the person of Mr. Hugh Munro, Crown Timber Agent at Port Arthur, Ont. Mr. Munro came from Oxford County and had been in the civil service for many years, beginning as inspector of buildings. He undertook his late position in 1889.

The CANADA LUMBERMAN learned with deep regret of the death of Mr. George M. Tanner, a member of the firm of Tanner Bros., lumber manufacturers, Waubesa, Ont. His demise occurred at his residence at Tannerville, Ont., on March 3rd, of pneumonia. He was a son of Mr. William Tanner, of Fonthill, Ont., and a nephew of the late Sir George Mortimer Tanner, of England.

The forestry movement has suffered a severe loss in the death of Mr. Thomas Conant, which occurred at his home in Oshawa, Ont., on Tuesday, March 14th, in his sixty-third year. Mr. Conant was a strong advocate of the preservation of our timber and was one of the first persons to attain success in the planting and growing of walnut trees. He was an author of repute, his pen having given to the world "Upper Canada Sketches" and "Life in Canada," both of which volumes have attained a large circulation. Mr. Conant was a member of the Historical Society of Canada and of the Canadian Forestry Association.

TRADE NOTES.

Park Bros., of Chatham, Ont., have recently made large shipments of boilers to British Columbia.

The Dodge Manufacturing Company, of Toronto, have recently secured a large order for machinery for the new million bushel grain elevator which the Grand Trunk Railway are building at Windmill Point, Montreal.

Incorporation has been granted to the Clark-Demill Company, Limited, manufacturers of woodworking machinery, engines, boilers, etc., Hespeler, Ont. The capital stock is \$100,000 and the provisional directors are George D. Forbes, John R. Phin and Anthony Ochs.

We are advised by the B. Greening Wire Company,

of Hamilton, Ont., that the fire on March 3rd did not destroy any of their works except the tower used in binding screen cloth. Other departments are running as usual and the company are in a position to fill orders promptly.

The Canadian Rubber Company, Montreal, held their annual meeting last month, at which it was decided to reconstruct their entire plant to meet the requirements of the Fire Underwriters Association and to erect a number of additional buildings. The annual report showed that the business of the company had almost doubled within the last two years.

The Bury Pulp Wood & Lumber Company, Robinson, Que., has been incorporated.

GIVES PLEASURE AND PROFIT.

Mr. Walter Tench, Watford, Ont., in renewing subscription to the CANADA LUMBERMAN, writes: "I am well pleased with your journal, and consider it a source of both profit and pleasure. Hoping you may long continue the publication with profit to both yourselves and subscribers."

LOOKING AFTER THE COOK

Give the cook **Clark's Corned Beef** and he'll look after himself. There's never any trouble when prime Canadian beef is used, and that is the only kind that ever enters the establishment of

WILLIAM CLARK, Montreal.

P. PAYETTE & CO.

Manufacturers of Saw Mill and Engine Machinery and all kinds of Marine Machinery.
PENETANGHISHENE, ONT.



These Mules Cannot Break This Yarn

BECAUSE IT WAS MADE BY THE

Consumers Cordage Co., Limited

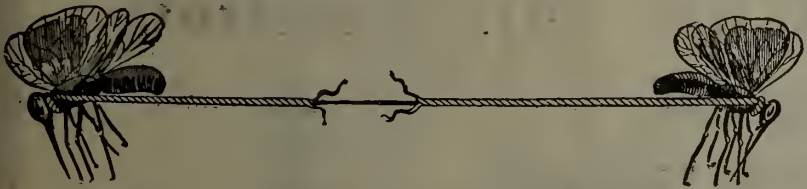

Poor Yarn is Dear at Any Price

We Manufacture

**Double and Single Lath Yarn,
Shingle Yarn, and Cordage**

Of Every Description

Our mills are equipped with the latest-improved machinery for making extra long lengths of Transmission Rope.

CONSUMERS CORDAGE CO., LIMITED

Montreal and Halifax

Sprocket Chain

WROUGHT AND MALLEABLE

15,000 FEET IN STOCK
AT WINNIPEG

Shafting Pillow Boxes
Bearings

Sawmill Work and Supplies of
every Description

THE
Manitoba Iron Works

LIMITED

901-909 Logan Avenue, WINNIPEG

THE LUMBER MUTUAL FIRE INSURANCE COMPANY

BOSTON, MASS.

STRENGTH

ECONOMY

NET ASSETS, DECEMBER 31, 1904

DIVIDENDS TO POLICY HOLDERS

\$592,990.05

33 ¹/₃ %

MAIL EXPIRING POLICIES WITH YOUR ORDER.

CONVENTION OF WHOLESALE LUMBER DEALERS.

The thirteenth annual convention of the National Wholesale Lumber Dealers' Association was held in Philadelphia on March 8th, 9th and 10th, President Lewis C. Slade, of Saginaw, Mich., in the chair. The sessions were unusually well attended and the delegates manifested a deep interest in the proceedings. On Wednesday evening the retail delegates tendered a reception to the wholesale dealers and their guests. Later in the same evening the Concatenated Order of Hoo-Hoo held a concatenation and smoker, which was attended by about two hundred persons.

The report of the Secretary, Mr. E. F. Perry, showed a gain in membership, which has now reached 314. During the year the number of subscribers to the Bureau of Information was increased to 179, making a net gain of eight for the year. The report of the Insurance Committee showed the creation during the past year of a new lumber insuring company by members closely identified with the National Wholesale Lumber Dealers' Association. Mr. R. H. McKelvey, of the Lumber Insurance Company of New York, read

an interesting paper entitled "Stock Company Insurance." The report of the Railroad and Transportation Committee reviewed at some length the steps which had been taken by the association to protect the rights of the members, one of the principal matters to receive attention being the furnishing of car stakes for open cars and getting the railroads to make proper allowance for the weight of these stakes.

Mr. Gordon C. Edwards, of W. C. Edwards & Company, Ottawa, extended an invitation to the association to hold its next annual meeting, or a special midsummer meeting, in the city of Ottawa. He assured the members of a royal reception and stated that the Ottawa Valley would feel extremely honored by such a convention. Mr. William T. Mason, of Mason, Gordon & Company, Montreal, seconded the proposition made by Mr. Edwards. The matter was left in the hands of the Board of Trustees for action, and it is understood that the proposition of holding a midsummer meeting in Ottawa is receiving favorable consideration.

The election of officers resulted as follows: President, Lewis Dill, Baltimore; first vice-

president, J. M. Hastings, Pittsburg; second vice-president, C. H. Prescott, Jr., Cleveland; secretary, E. F. Perry, New York; treasurer, F. W. Cole, New York. The following were elected as directors to serve for three years: Lewis Dill, Baltimore; C. H. Prescott, Jr., Saginaw Bay Company, Cleveland; Geo. F. Craig, Geo. F. Craig & Company, Philadelphia; Frank W. Lawrence, Lawrence & Wiggin, Boston; James B. Wall, Buffalo Hardwood Lumber Company; A. L. Stone; W. W. Knight, Long-Knight Lumber Company, Indianapolis.

The Wire-Woven-Wood Manufacturing Company has been formed recently at Woodbridge, Ont., to carry on a lumber and woodworking business and to manufacture wire woven wood baskets.

In the description of the Rat Portage Lumber Company's planing mill at Rat Portage, Ont., which appeared in the March number of THE CANADA LUMBERMAN, it was stated that the McGregor-Gourlay Company, of Galt, supplied all the machinery. We are advised by Messrs. J. L. Neilson & Company, of Winnipeg, that they furnished eight of the principal machines, also 62 out of the 70 machines installed in the new sash and door factory of the same company at Winnipeg. They further point out that the contract for the plant of the mill at Harrison River, B.C., has not yet been awarded.

THE JENCKES MACHINE CO., Limited

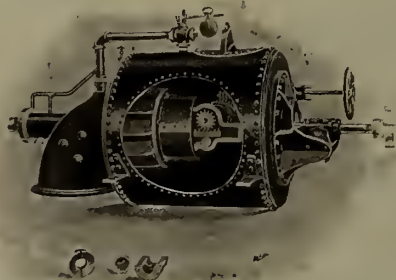

THE CROCKER TURBINE THE EXPRESS GRINDER

For obtaining Results in the Pulp Mill this Combination takes the Lead.
Used by the Foremost Pulp Makers in the Dominion.
Full Particulars on Request.

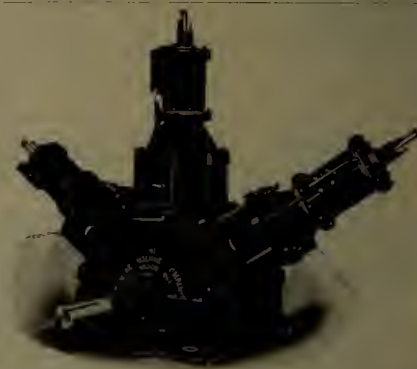

HEAD OFFICE AND WORKS, 48 Lansdowne St., SHERBROOKE, QUE.

BOILERS FOR ALL SERVICES

Return Tubular, Water Tube, Marine,
Lancashire, Etc.

*Engines, "Worthington"
Pumps, Forgings and
Castings of every description*

THE JOHN McDOUGALL
CALEDONIAN IRON WORKS CO., LIMITED,
MONTREAL



One of two Marine Boilers built in our shops for the Richelieu & Ontario Navigation Co's Steamer 'Carolina.' Length 21' 4", diameter 13' 4", height 11' 10", weight 37½ tons.

SOMETHING
NEW
IN
LEATHER BELTING

“**AMPHIBIA**”

GUARANTEED
ABSOLUTELY WATERPROOF
FOR

SAW & PULP MILLS
& ALL WET PLACES

*WRITE FOR
DESCRIPTION & PRICES*

SADLER & HAWORTH

TANNERS & MFRS.,
MONTREAL — TORONTO.

CANADIAN FAIRBANKS COMPANY.

The business of The Fairbanks Company in Canada, including all their selling agencies, contracts, organization and warehouse stocks of goods at Montreal, Toronto, Winnipeg and Vancouver, has been purchased by Mr. Henry J. Fuller.

Mr. Fuller started the business for The Fairbanks Company in Canada six years ago, and since that

time it has rapidly grown; The Fairbanks Company not seeing their way clear to manufacture in Canada, Mr. Fuller offered to buy the business in order to reorganize it as a Canadian institution, and the business will be conducted, on and after March 15th, as The Canadian Fairbanks Company, Limited, Mr. Fuller being president and treasurer. It is his intention to begin very shortly the erection of a large plant for

manufacturing the many specialties which they have heretofore imported.

The first step will be to remove the Montreal warehouse into new quarters at 444-446 St. James street on the first of May next, the old quarters on Craig street being retained for the present, as it is expected the extra space will be needed for the increase of business.

The Cook & Bros. Lumber Co.

Of Ontario, Limited MILLS at SPRAGGE, Algoma Dist., Ont. on "Soo" Branch C.P.R.

OFFICES Manning Arcade, Toronto Coristine Building, Montreal And at Mills at Spragge.

MANUFACTURERS OF

White and Red Pine Lumber and Lath

Water Shipments

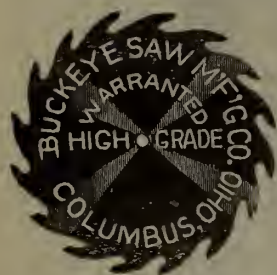

BUCKEYE SAW M'FG. CO...

MANUFACTURERS OF

High-Grade Saws

Quick and careful work on Repairing. All kinds of Mill Supplies.

REYNOLDS BROS., Proprietors 267 N. Water Street, COLUMBUS OHIO.

OILS

Manufacturers High-grade Cylinder, Machine and Sawmill Oils.

Calypsol Grease

for Sawmill Purposes a Specialty. Our products are made from finest Pennsylvania stocks.

We solicit your correspondence.

St. John St., MONTREAL. Offices and Works: Manchester, Eng. Hamburg, Germany. Newark, N. J. Chicago, Ill.

Commercial Oil Co., Hamilton, Ont.

FRANK DENTON, K. C. HERBERT L. DUN W. MULOCK BOULTBEE.

DENTON, DUNN & BOULTBEE Barristers, Solicitors, Notaries, etc.

National Trust Chambers. TORONTO

THE MONTHLY JOURNAL

Concrete

Devoted to cement manufacture and the various forms of concrete construction. \$1.00 a year; single copy 15c. CONCRETE PUBLISHING CO., - Detroit, Mich

Please mention this paper when corresponding with advertisers.

TENTS, OIL CLOTHING, and TARPAULINS, HORSE and WAGON COVERS FOR LUMBERMEN'S USE A SPECIALTY.

EVERYTHING IN CANVAS MANUFACTURED.

The Montreal Tent, Awning and Tarpaulin Company,

Send Prices on Application.

25 Youville Place, MONTREAL

FOR THE CAMP TABLE

- Mess Pork Smoked Hams Short Cut Pork Roll Bacon Plate Beef Pure Lard Dressed Fresh Beef Pork Sausage Long Clear Bacon, Butter, Cheese, &c.

Write us for Special Prices on Car Load Lots.

THE PARK BLACKWELL CO., L'T'D

PORK AND BEEF PACKERS TORONTO

Normandin Cement Block Machine



There's Money in the Block Business

Experience not Necessary for Success.

The NORMANDIN machine does the work.

THINK IT OVER, and decide quickly to start a Block Yard in your town. Others are making a success of the business—You can too. Write to-day for particulars of the NORMANDIN MACHINE. Hundreds of them in use daily. Hand labor and a little common sense will turn out a perfect stone on the NORMANDIN. This is the machine that took the Highest Award St. Louis Fair, 1904. The United States Government Engineers will buy nothing but the best. They bought and are using the NORMANDIN—IT MUST be right.

The NORMANDIN complete equipment comprises over 200 parts and weighs 3,000 lbs.

SOLE AGENTS FOR CANADA

The Cement Block Building Co., Limited

Winnipeg Vancouver Toronto Largest Cement Block Manufacturers in Canada

1,000 Mershon Band Resaws



IN DAILY USE

BUY DIRECT AND GET

GENUINE

W.B. MERSHON & CO. Saginaw Mich., -- U. S. A.

ATKINS ALWAYS AHEAD!



QUALITY IS THE THING!

Substance, not the Shadow of Quality

Characterizes the Silver Steel Saws bearing the celebrated "AAA" trade mark. Superiority of material, our patent process of tempering, perfection of grinding and experience and skill in workmanship are the leading features in the make-up of an Atkins Saw. These qualities insure perfect running saws and satisfaction to the user. The highest intrinsic value ever offered and the most efficient service possible to obtain are secured when you purchase an Atkins Saw. A trial is convincing proof. Think it over and let's have your order now.

Our Machine Knives, too, are made with a view of retaining you as a permanent, satisfied patron. What more can we say?

Mill Supplies of every description. Write for our 1905 Saw and Saw Tool Catalogue and Sawyer's Hand Book. It's free.

E. C. ATKINS & CO., Inc.,

Leading Manufacturers of Circular, Band, Cross-Cut, Hand and Wood Saws, Etc.

Factories and Home Office,
Indianapolis, Ind.

Canadian Branch,
56 King St. East, Toronto, Ont.

THE E. L. PURVIS CO.,
18 COLBORNE ST. TORONTO, ONT.



PIPE AND BOILER COVERINGS

Asbestos Mineral Wool
and all kinds of Fireproofing

Material Agents for

FAMOUS MICA COVERINGS

Fire Clay Products

THE GLENYARDS FIRE CLAY CO.

BONNYBRIDGE, SCOTLAND.

Cablegrams : Glenyards, Bonnybridge.

Codes used, A.B.C. and Glenyards.

Manufacturers of all kinds of **Fire Clay Goods, Ganister and Silica Goods, for Iron and Steel Works and Gas Works, including Boiler Seating Blocks and Covers of all sizes. Ground Fire Clay, Ganister and Silica** in all kinds of Packages

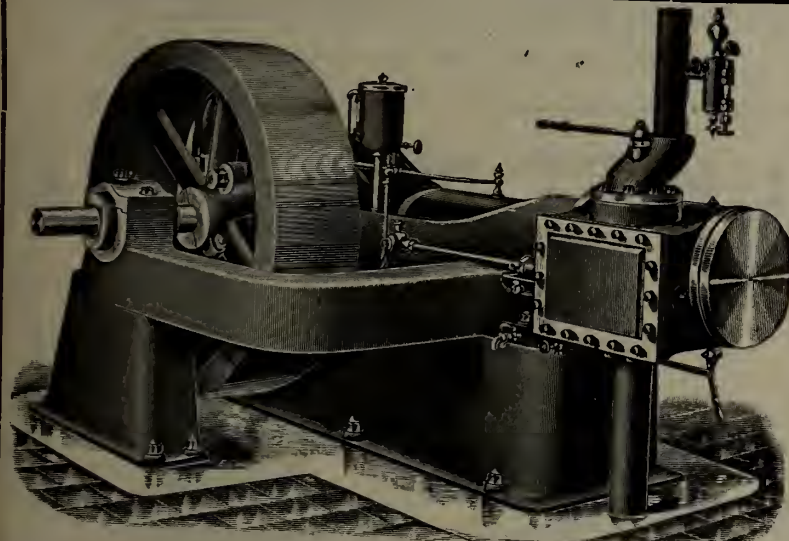

GIVES NO TROUBLE

A mill owner writes us: "The 16x16 Robb-Armstrong Automatic Engine installed in our saw mill in 1903 has proved very satisfactory. It has been running steadily five months each sawing season of 1903 and 1904 and has given us no trouble whatever. We drive with it a large rotary, lath mill, patent haul-up, complete sawdust conveyor throughout the mill, live rolls, trimmers, slab saws and planers. We do not have to develop its full power to do this work. The governor is very sensitive, there being only a variation of 3 per cent. when saw is running in and out of cut. We use steam feed to drive our rotary and put through the mill 750 to 800 logs per day."

ROBB ENGINEERING CO., Limited, Amherst, N. S.

Agents : { William McKay, 320 Ossington Avenue, Toronto.
Watson Jack & Company, Bell Telephone Building, Montreal.
J. F. Porter, 355 Carlton Street, Winnipeg.



IN OUR LINE WE LEAD

McFarlane Patent Wrot Forged Steel Socket Cant Dogs

Leads them All

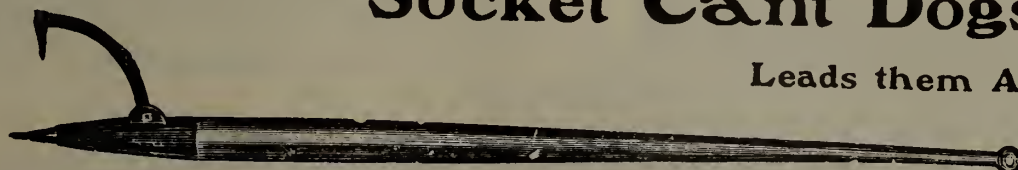

Used in every Lumbering District from the Atlantic to the Pacific Ocean

Extra Fine Quality Split Rock
Maple Handles

Round and Duck Bill Peaveys and
Cant Hooks

Write for quotations. If once used you will never return to the old malleable sockets.

THE McFARLANE-NEILL MANUFACTURING CO., Limited ST. MARY'S, YORK COUNTY
New Brunswick

THE DYMENT FOUNDRY CO.

BARRIE, ONT.

Manufacturers of

ENGINES, BOILERS, STEAM FEEDS

AND A COMPLETE LINE OF

SAW, SHINGLE AND LATH MILL MACHINERY

Can ship mills in a week's notice. Write us for prices and catalogue.

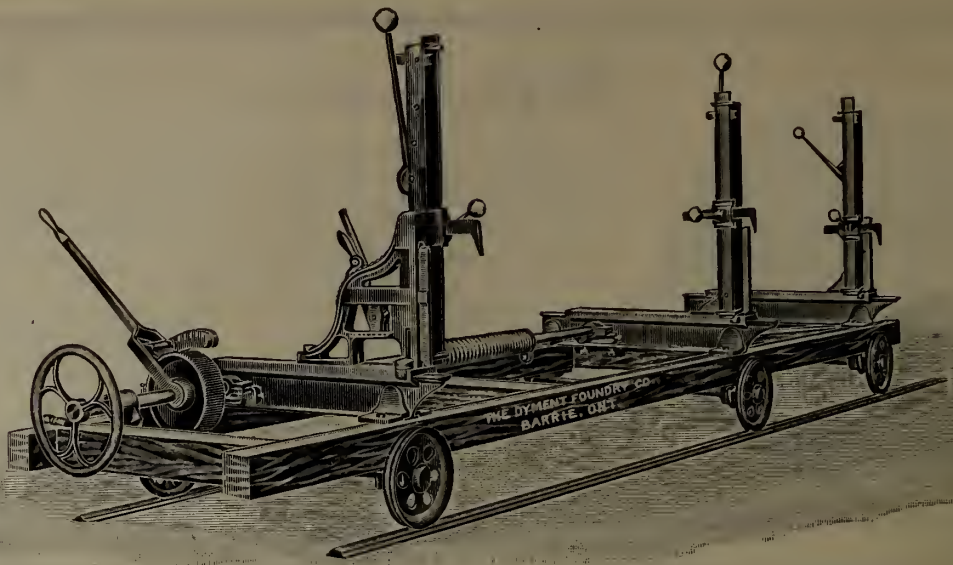

This is a light running Carriage and is quite suitable for small mills. Its capacity is about 15,000 feet per day. The wheels are 14 inches in diameter. The axles are $1\frac{3}{4}$ inches in diameter and go across frame. They are fitted with self-oiling boxes. The bunks are of steel. Blocks will recede 38 inches. An overset lever is supplied when desired, also spring receder and band brake wheel.

The feed on this frame is self-contained and can be used for either rope or rack and pinion. All the frictions have 7 inch face, two of them are made of paper, the other two of iron. The mandrel is made of steel and is 3 7-16 inches in diameter. The mandrel pulley is made in different sizes so as to suit the speed and width of drive belt. If desired this pulley may be put inside of frame

WE MANUFACTURE AN IRON SAW FRAME

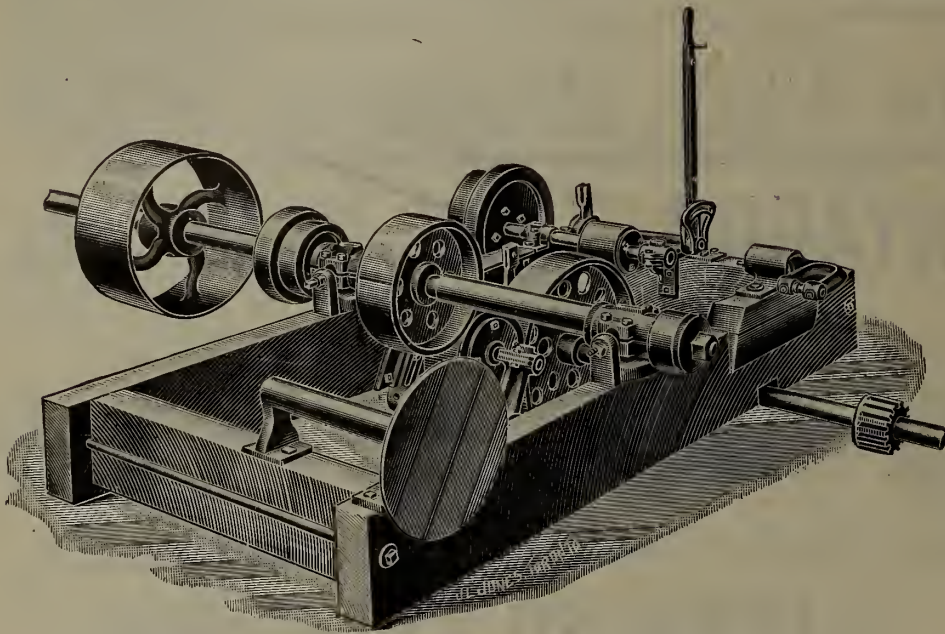

GANG LATH and PICKET MACHINE

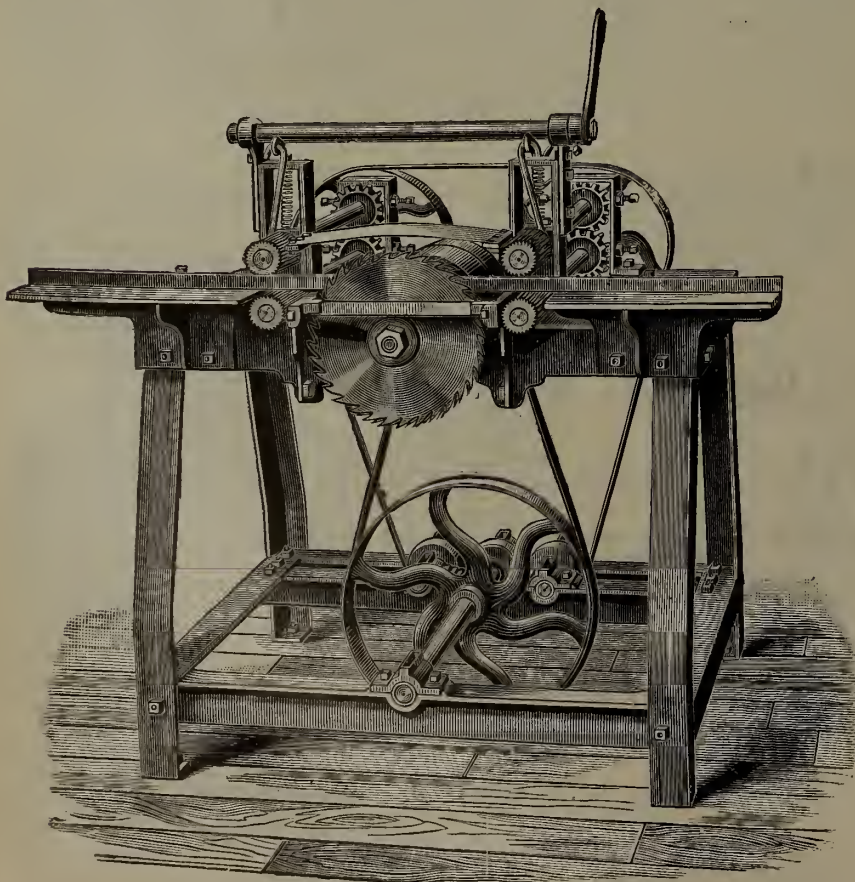

There is no better machine made for the price asked. It has a solid iron frame, which with the saw arbor bearings is cast in one piece. The drive pulley is 8 in. dia. and 9 in. face. Turned inside and out, and very finely balanced. The feed and press rolls are milled out of solid steel and tempered hard. It carries four 12 in. saws, and is adapted for both Lath and Pickets. With the Lath Bolter, its companion, it is capable of turning out a larger amount of work every day, probably more than any other medium price machine on the market.

I have one of these machines in stock now, very little used, and guaranteed in perfect order. Will sell cheap.

Send for Catalogue of Saw Mill, Lath Mill and Shingle and Heading Mill machinery.

F. J. DRAKE, - - Belleville, Ont.

Detachable Chain Belt

—AND—

CONVEYING

MACHINERY



William R. Perrin & Company

Limited

TORONTO, CANADA.

WOODWORKERS SAY
 "The convenience to the Sawyer and the saving in lumber make the **STANDARD AUTOMATIC SAW GUAGE** an article of much merit."

WRITE TO
SPECIALTY MFG. CO.
 DETROIT
 Mich.

Reliable Veterinary Remedies

No logging outfit is complete without a supply of reliable veterinary remedies. Getting the wrong kind means the loss of the use of your horses when time is valuable.

Johnson's Veterinary Remedies are guaranteed never to fail when used as directed. You get your money back if they ever do.

Johnson's Horse Liniment No. 1.
A penetrating Alcoholic Liniment. Put up in one gallon jugs, with full directions, per imperial gal. \$4.50

Johnson's Horse Liniment No. 2.
A combination of the best oils used as liniments, imp. gallon . . . \$3.00

Johnson's Horse Colic Remedy.
A sure and speedy cure for colic. Imperial gallon \$5.00

Johnson's Veterinary Healing Ointment.
Positively the best all-round healing ointment made. In use by the largest owners of horse flesh in Canada. Put up in 2 lb tins, each . . . \$2.00

or in 1/4 lb tins, per dozen . . . \$3.00

Johnson's Condition Powders. (Concentrated). Put up in bulk, per lb 3c.

These goods being put up in bulk are more economical than others, as cost of bottling, etc., is saved.

CAMP REMEDIES.

In addition to our Veterinary Remedies we make a line of medicines for lumbermen, including a strong, penetrating liniment, healing ointment, cholera cure, liver pills, cough syrup, in fact anything in the form of Camp Drug Supplies. We know that there are no better remedies made than those we offer. There may be others nearly as good, but they lack our guarantee. Satisfaction or money back. A trade discount of 10% allowed off all orders amounting to \$100.

Send postal for printed matter.

A. H. JOHNSON
Wholesale Druggist
Collingwood, Ont.

SHERMAN'S FLOORING MACHINES

PATENTED

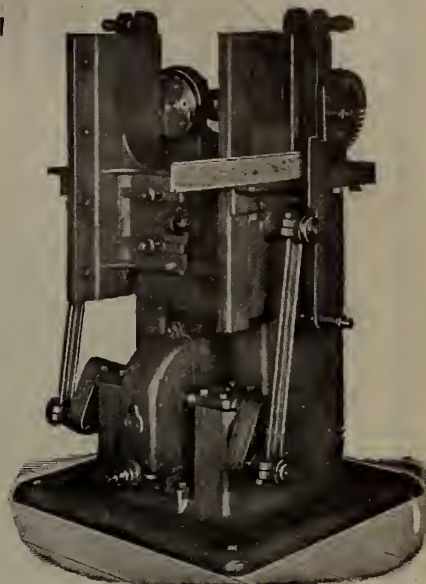

Above cut shows our End Matcher, the best machine in the market for end matching flooring strips. They do rapid and accurate work, and are durable—therefore used by leading flooring manufacturers. Make your flooring profitable by end matching it.

We Make the

SHERMAN SIDE BORING MACHINES

and the

SHERMAN FACE BORING MACHINES

To bore flooring while it is being run on the flooring machine. Write for circular and list of users.

W. S. SHERMAN CO.

1150 Holton St., Milwaukee, Wis

This is the Band Wheel Grinder

We have been talking about

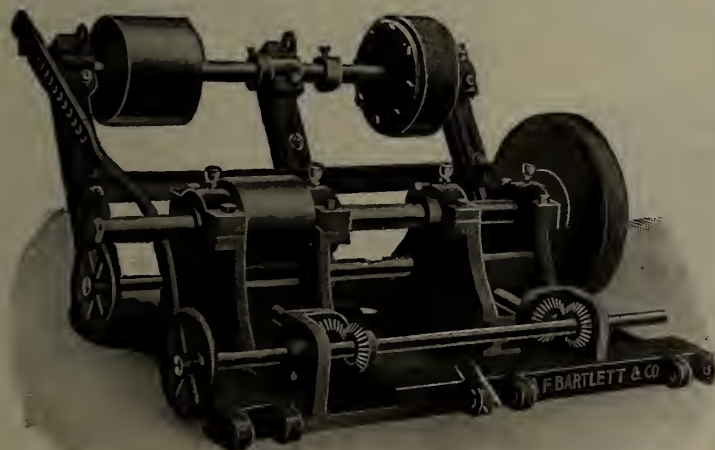

IT PAYS FOR ITSELF IN THREE TIMES USING

For full description and price write to the manufacturers

A. F. BARTLETT & CO.

Saginaw, Mich.

Cowan & Co. of Galt, Limited

GALT, CANADA

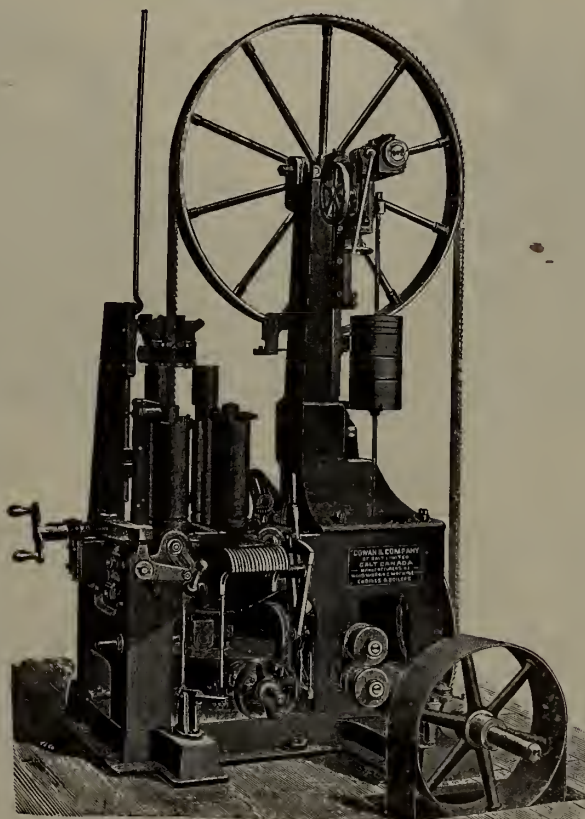

No. O Band Resaw, M167

We build this machine in different styles and sizes, with wheels 42", 48", 54" and 60" diameter. Also a full line of the most up-to-date Wood Working Machinery of superior material and workmanship.

Write for cuts and prices.

PLANING MILL MACHINERY

We can fit you out, as we are manufacturers of the largest line of Wood Working Machinery in the world.

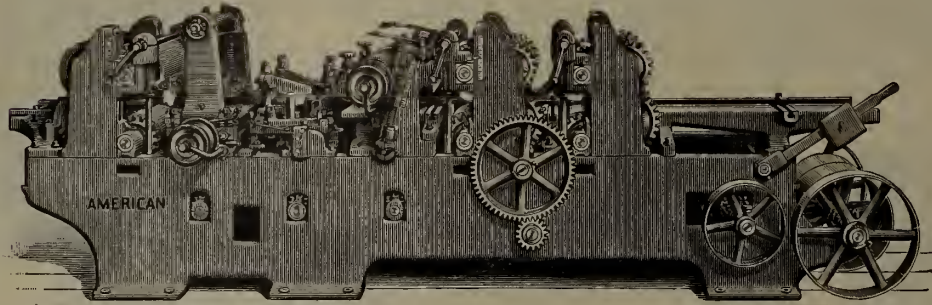

Hoyt "New Series" Planers and Matchers, with Upper Cylinder Cutting First. Works 9", 15", 19", 24", 26" and 30" by 8" or 12" thick.

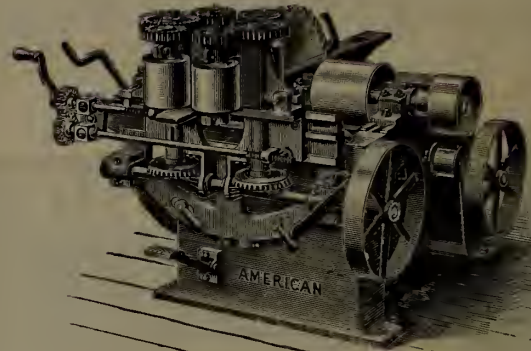

Fig. 541. Hoyt No. 4, 74" Re-saw.

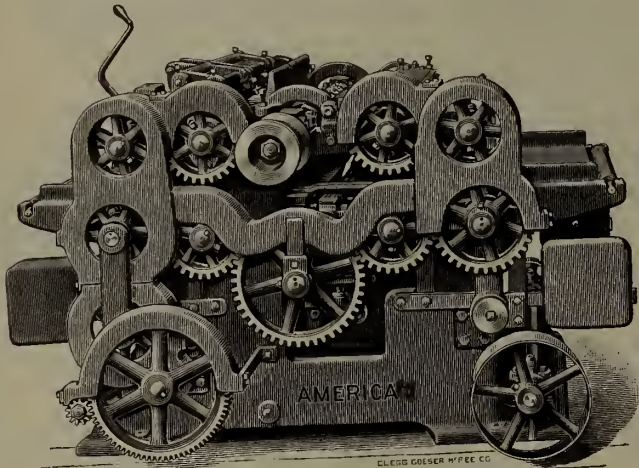

Fig. 7231. American No. 15, 26" or 30" by 8" or 10" Double Surfacers.

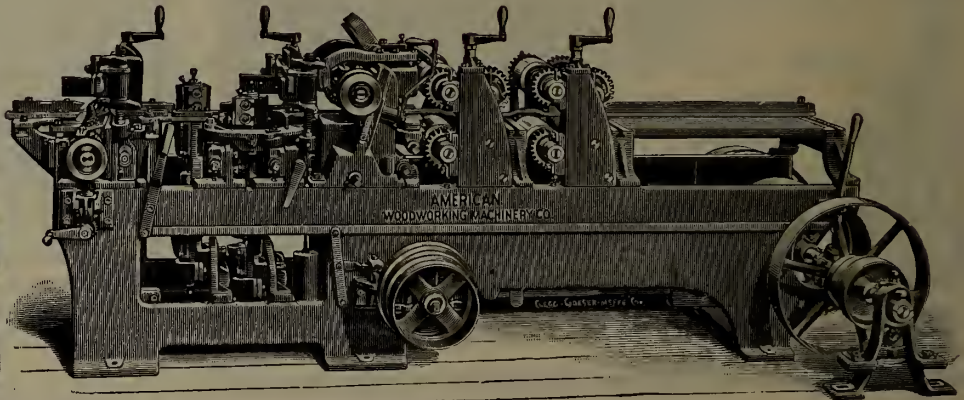

Fig. 826. Glen Cove 8", 10" 12" and 14" Inside Moulders.

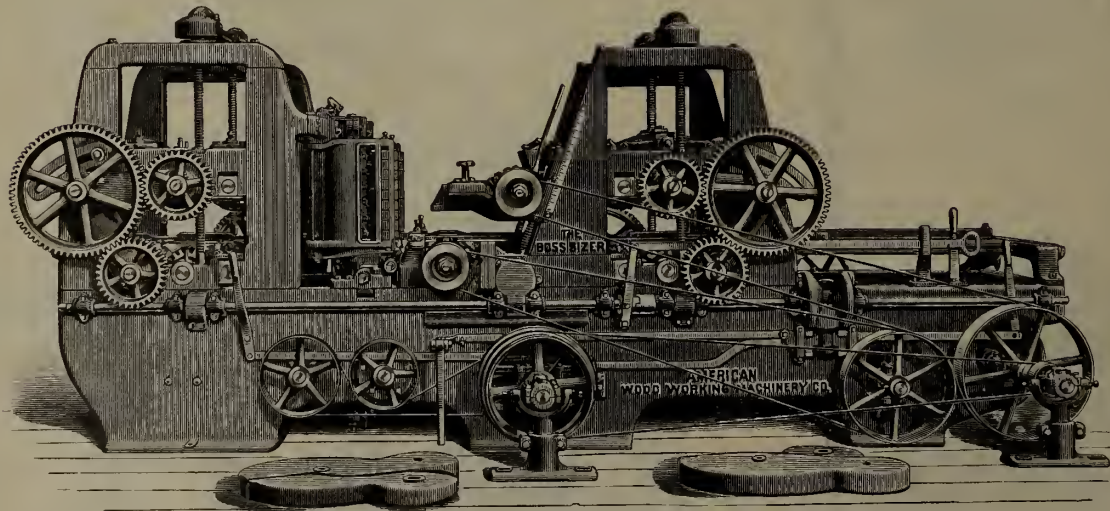

Fig. 640. Glen Cove 8-Roll Boss Sizer, works 30" wide by 16", 18" or 20" thick.

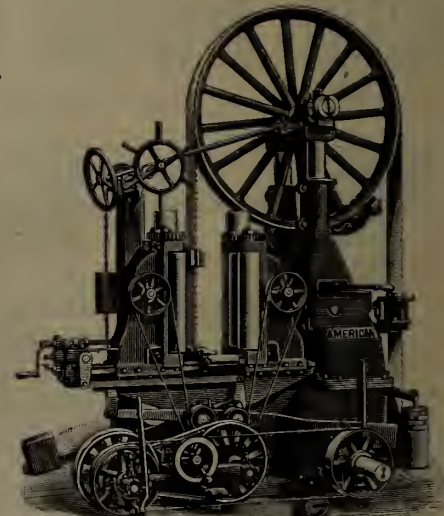

Fig. 500. Clement 60" Band Re-saw.



American Wood-Working Machinery Company

136 Liberty Street, NEW YORK CITY



IT'S OUT

Our New XXXX Catalog is just out, showing and describing the most complete and comprehensive line of Hand and Power Feed Shingle, Heading and Box Board Machinery ever created. This book is

YOURS FOR THE ASKING

and should be in the hands of every manufacturer of Shingles, Heading or Box Boards in the country. A postal request brings it.

PERKINS & CO.

GRAND RAPIDS, MICH.

THE CELEBRATED

"Tower" Line of Edgers and Trimmers

These machines are preminently simple and practical. They contain everything that is essential and nothing that is superfluous. This, our exceptional facilities and the vast number of them we turn out, enable us to make extremely low prices on edgers and trimmers that, in design, material and workmanship, cannot be excelled.

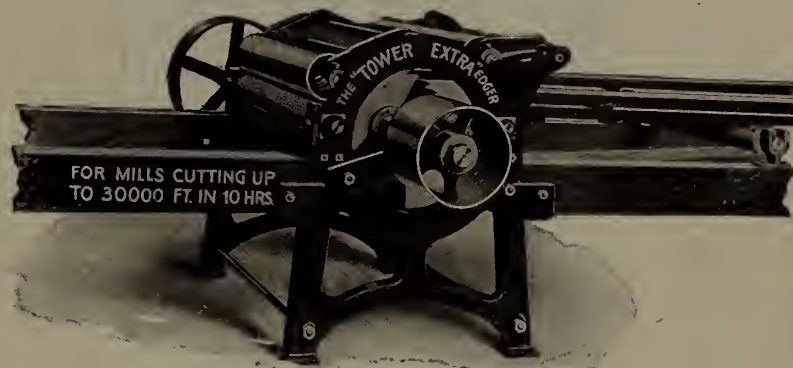

We wish to call especial attention to The "TOWER" 2 and 3-saw Edger, No. 1, 2 and 4, Improved, for mills cutting not to exceed 20,000 ft. in ten hours. These edgers are especially well adapted for small mills because (1) they require little power, (2) they take up little room, and (3) they are extremely low prices. Why pay twice as much for a machine requiring double the power and floor space, and doing no better work?

Our complete line comprises: **THIRTY EDGERS AND TRIMMERS.**

This is without question by all odds the most complete line of edgers and trimmers manufactured by any one concern in the world.

We also manufacture the celebrated Gordon Hollow Blast Grate.

The Gordon Hollow Blast Grate Co., Greenville, Mich.
Established 1889

The largest manufacturer of Blast Grates, Edgers and Trimmers in the World.
SEND FOR CATALOGUE D.



The "Alligator" Steam Warping Tugs

SIDE WHEELS OR TWIN SCREWS

The Twin Screws are arranged with flexible joint to raise up in crossing portage

MANUFACTURED BY

WEST & PEACHEY, - Simcoe, Ont.

Cables carried in stock for renewals

The Gravenhurst

"BOSS" SHINGLE MACHINE

The Best Machine on the Market

The Simplest in Construction of any Machine Built

We build Shingle Machines both Horizontal and Vertical
We also build All Kinds of Saw Mill and Shingle Mill Machinery

Send us Your Orders, Large or Small—We can Fill Them

Write for Catalogue

B. R. MOWRY & SONS

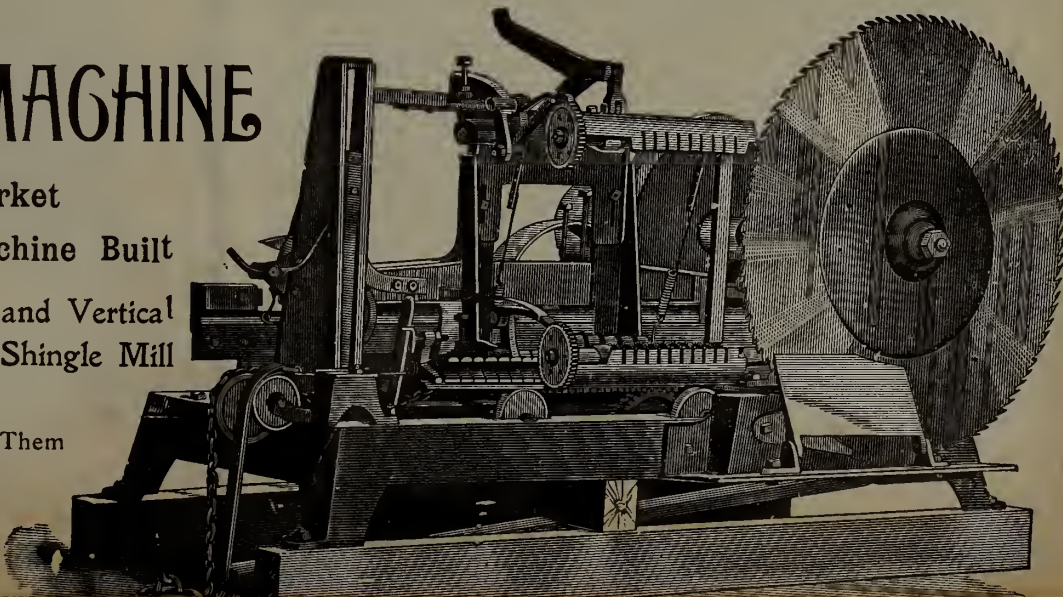

THE A. J. BURTON SAW CO.

LIMITED

Vancouver, B. C.

Inserted-tooth, Shingle and Band

SAWS

File-room Machines and Tools,
Emery Wheels,
Silver Solder, etc.

BITS AND SHANKS

BRITISH COLUMBIA AGENTS FOR R. HOE & CO.

REPAIRS executed promptly by expert workmen.
INSERTED-TOOTH SAWS REMILLED & REFITTED.

WE ARE HERE ON THE GROUND.

SAVE FREIGHT AND DUTY
TRY US.

THE HOE CHISEL TOOTH SAW MAKES MONEY FOR THE MILLMAN

IMITATED
BUT
NEVER
EQUALED.

THE GENUINE MADE ONLY BY
R. HOE & CO.
504 to 520 GRAND ST.
NEW YORK.

Lumbermen, Attention!

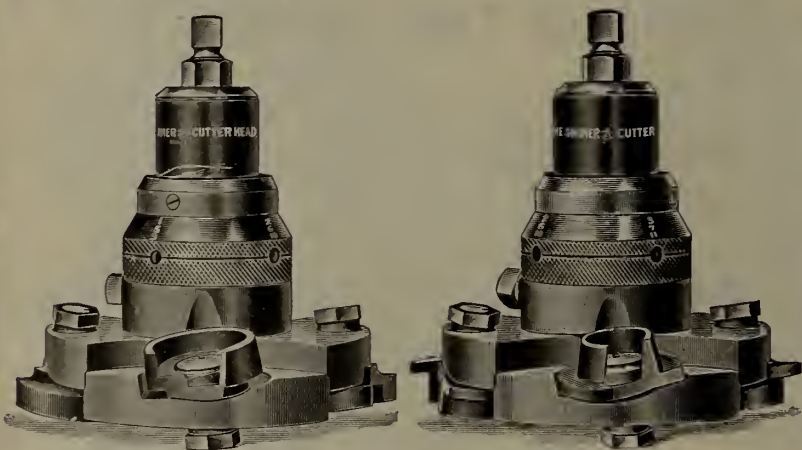

YOU manufacture lumber as a business, and use matching and moulding machines, which should be equipped with The Shimer Cutter Heads to receive their best service. The convenience of these tools in working Flooring, Ceiling, Siding, Ship Lap and Jointing is being demonstrated every day from the fact that more than 100,000 of them are in use throughout the United States and foreign countries. If you do not use them, ask your neighbor or any practical mill man concerning their convenience.

Don't be prejudiced—ask.

Then send to us for full particulars and learn the low prices at which we can fit you out with the best Steel Forged Cutter Heads that can be produced. Don't forget that we send them on trial to responsible mill men anywhere; they can be returned at our expense if they don't prove to be the greatest time and labor saving tools for the purpose.

Our Catalogue will give you a lot of information about The Shimer Cutter Head, and we will mail it free to any address.

... Address ...

SAMUEL J. SHIMER & SONS, MILTON, PA.

THE BEST IN THE WORLD

There is no doubt about the fact that the

RODGERS Adjustable Log Siding Machine

is without a peer.

This machine will slab opposite sides of a log in one operation at the rate of two thousand logs in 10 hours.

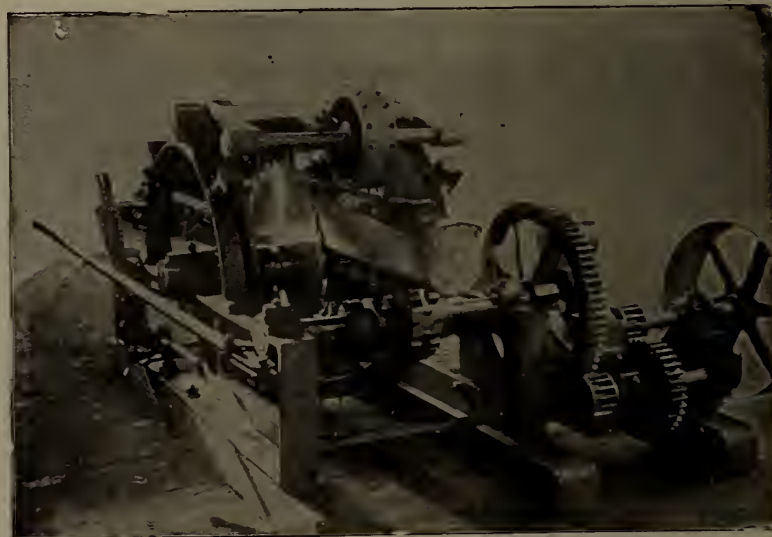

A MONEY MAKER

A MONEY SAVER

HUNDREDS OF LETTERS RECEIVED LIKE THIS :

Rock Island, Ill., Nov. 25, 1902.

RODGERS IRON MANUFACTURING CO., Muskegon, Mich.

Gentlemen:—Replying to yours of recent date and referring to your adjustable log siding machine, must say it has given us general satisfaction, and we have done good work with it. Any one desiring a machine of this style for the purpose of slabbing small logs, we would recommend yours.

Respectfully,

WEYERHAUSER & DENKMAN.

For full particulars and literature, mention this paper and address :

RODGERS IRON MFG. CO. MUSKEGON, MICH.

Perfect Swing Shingle Mill

Fitted with our "Automatic Trip."

Best Swing Shingle Machine on the Market today for cutting Shingles, Headings, Etc. . .

It will pay you

to write for description and price before placing your order.

We also Manufacture a complete line of . . .

SAW MILL MACHINERY, ENGINES AND BOILERS

THE **Owen Sound Iron Works Co.** LIMITED

Owen Sound, Ont.

SEND FOR CATALOGUE

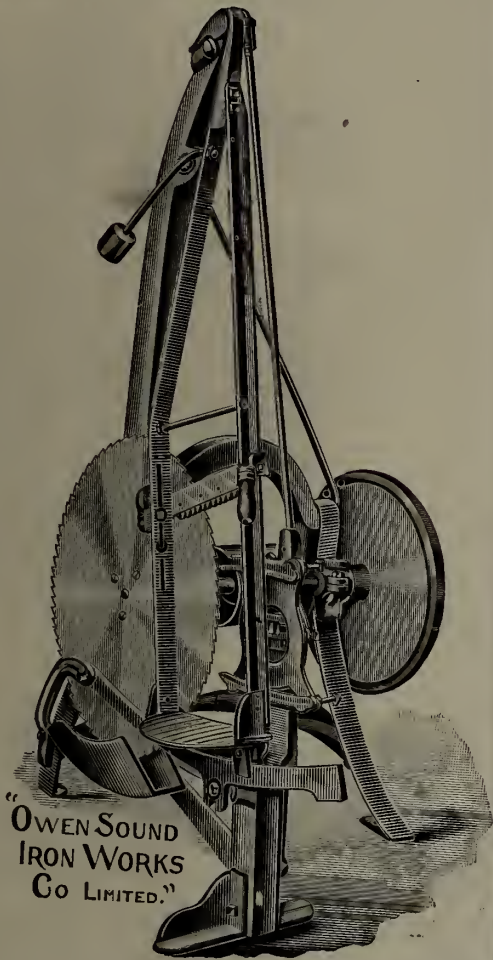

"OWEN SOUND IRON WORKS CO LIMITED."

RUBBER BELTING

For Transmitting Elevating and Conveying



Rubber Hose for Water Steam Air Suction Fire Protection

THE GUTTA PERCHA & RUBBER MFG. CO. OF TORONTO, LIMITED.

TEMPORARY OFFICES: 15 EAST WELLINGTON STREET, TORONTO, CAN.

Branches: Montreal, Winnipeg.

New 200 Page Green Book 1904 EDITION.

"Saw and Knife Fitting Machinery and Tools"

MAILED FREE ON REQUEST.

A Book for Mill and Factory Managers, Superintendents, Foremen and Saw Filers.

BALDWIN, TUTTILL & BOTON, GRAND RAPIDS, MICH., U.S.A.



B. T. & B. Full Automatic Knife Grinder. Style D

SAW AND KNIFE FITTING

THE NEW B. T. & B. MANUAL

Revised edition. 144 pages. Copiously illustrated and Durably Bound. Is an exhaustive treatise on the care of Saws and Knives.

A Practical Book for Saw Filers.

Mailed Postpaid on Receipt of Price

THE "B. T. & B." LINE

NEED ANYTHING ?

- Sharpeners, Swages, Stretchers, Shapers, Side Files, Shears, Retoothers, Brazing Machines, Filing Clamps, Lap Grinders, Lap Cutters, Patch Machines, Crack Drills, Hammering Benches, Bench Grinders, Band Filers, Band Setters, Pulleys and Stands, Brazing Forges, Saw Sets, Saw Gauges, Swage Bars, Upsets, Straight Edges, Tension Gauges, Back Gauges, Leveling Blocks, Anvils, Hammers, Speed Indicators, Emery Dressers, Knife Grinders, Knife Balances, Shingle Saw Grinders, Burr Gummars, Post Brackets, Stretcher Bench Brackets, Cutters, Marking Stamps, Saw Guides, etc.

Andrews

Stands for

Three Comforts
Quality Efficiency Price

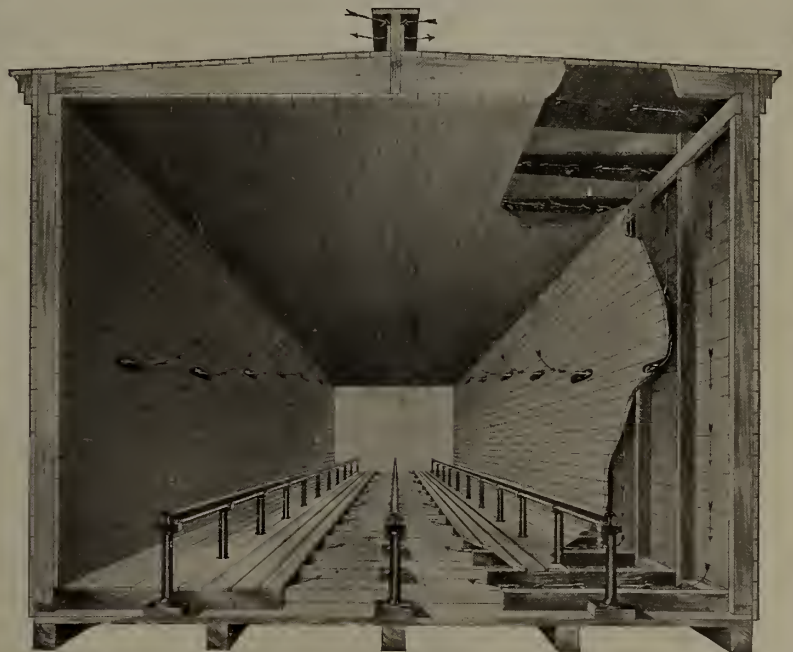

Kilns That Dry Your Lumber Without Drying Up Your Bank Account

Write for Catalogue

The A. H. Andrews Co.

174-176 Wabash Avenue

CHICAGO, U. S. A.

Waterous Steam-Acting Saw Mill Machinery

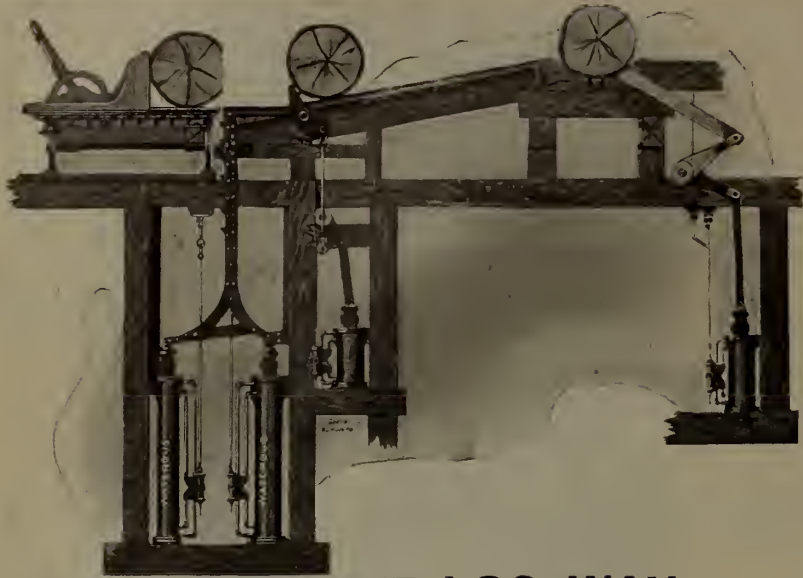

COMPLETE LOG WAY

This Cut represents a modern, up-to-date Single Log Way.



LOG DECK WITH DOUBLE KICKER

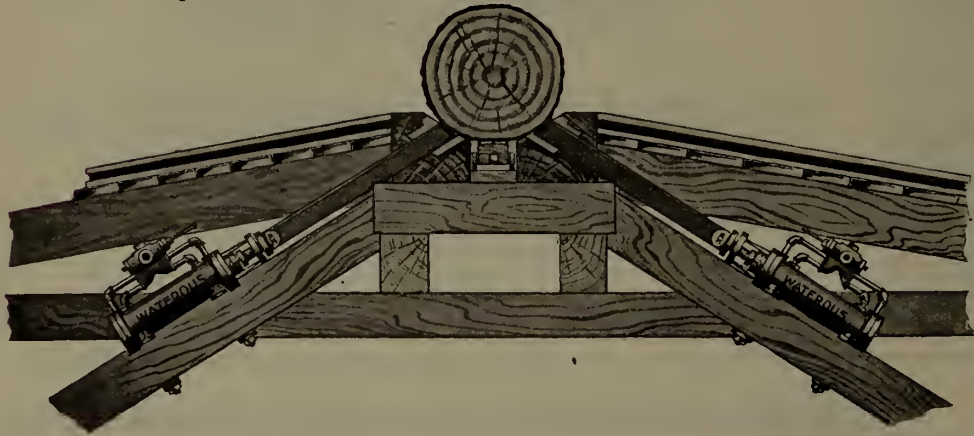

SIMPLE
STRONG
DURABLE



THE NEW LOG STOP AND LOADER

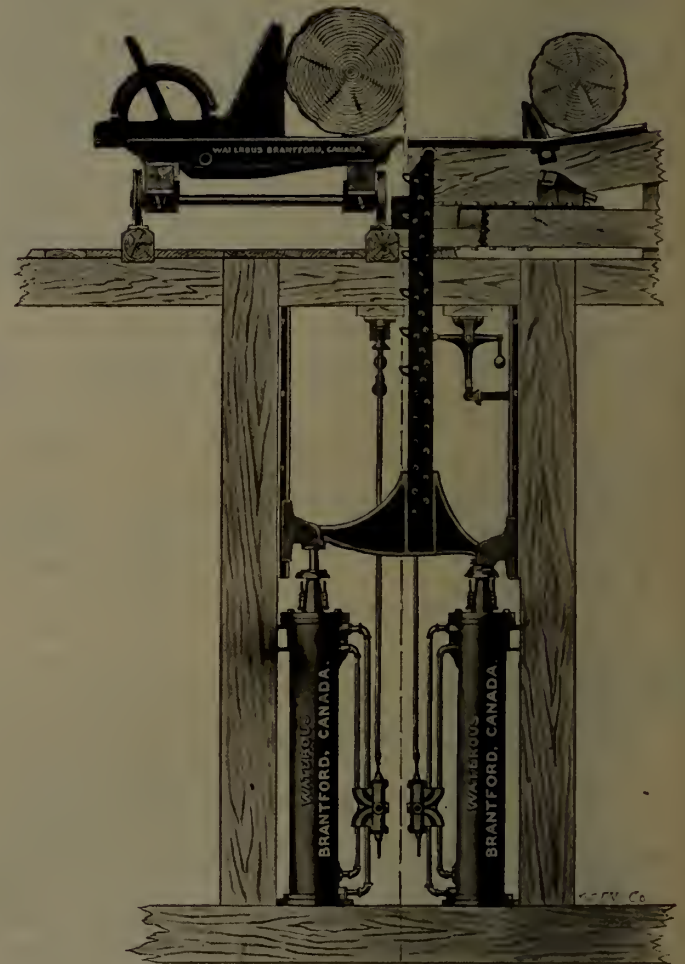

THE DOUBLE STATIONARY CYLINDER STEAM NIGGER

Four sizes made:
No. 1—Extra Heavy. No. 2—Heavy.
No. 3—Medium (standard size). No. 4—Pony size (for light logs).

It is admitted that this Nigger has done more for the saw mill world than any other machine, saving mill men thousands of dollars.

Write Us for Catalog Fully Describing These Machines

WATEROUS, Brantford, Canada

NATURAL DRAFT MOIST AIR . . . DRY KILNS
LUMBER TRUCKS and TRANSFER CARS

Write for prices and particulars of the most simple and efficient Natural Draft Dryer on the market. Testimonials and list of users sent on application. Every square inch of heating surface is utilized to the uttermost and perfect ventilation and circulation is obtained by a very simple arrangement of ducts. Write for particulars to

SHELDON & SHELDON,
GALT, ONT.

FORMERLY McEACHREN HEATING & VENTILATING CO.

Reduced Expenses

in the operation of your mill will always follow the use of

"MIDLAND" BEARING METAL

because it is sold at a reasonable price; it will stand up under any amount of abuse and requires less oil than most others, while you must not forget that

IT IS GUARANTEED

GEORGIAN BAY ENGINEERING WORKS
 Midland, Ontario

If Your Dry Kiln Trucks Don't Run Right

—If they are annoyingly subject to break-downs under ordinary conditions the operation of your plant is being unnecessarily hampered. You can remedy all this by equipping your kiln with

The Standard Channel Steel, Roller Bearing Dry Kiln Trucks



These trucks never trouble. They're built for a lifetime's satisfactory service; have frame of steel channels, MALLEABLE IRON wheels and spreaders, and steel axles.

They're easy running—because the steel roller bearings have CONE-SHAPE ENDS that minimize the friction.

While they are not the cheapest-priced trucks, they're by long odds the cheapest IN THE END.

The different styles in which "STANDARD" Trucks are made are told about in detail, and illustrated, in our Catalogue "D." Write for a copy.

The Standard Dry Kiln Co.
 Indianapolis, Indiana



FOR **DRY KILNS**

that will season lumber of all kinds and under all conditions, whether partially air-seasoned or green from the log, in shortest time and at least cost, entirely free from checking, warping or case hardening,

Write to—

McEACHREN HEATING & VENTILATING COMPANY, GALT, CANADA.

Don't Hurry—Just Keep Moving

Operators of Shaping Machines—and others who know—will tell you that one-half of their time is devoted to "fitting up" and "getting ready."



OUR "SOLID STEEL SHAPER CUTTERS" (GUARANTEED)

Are used by manufacturers who by experience know that the "first cost" is very small compared with the "continual cost" when "open heads" are used. OUR CUTTERS are always ready for use, which means "always something doing" on the Shaping Machine. In ordering—send sample of mould, diameter of spindle, and size of collars.

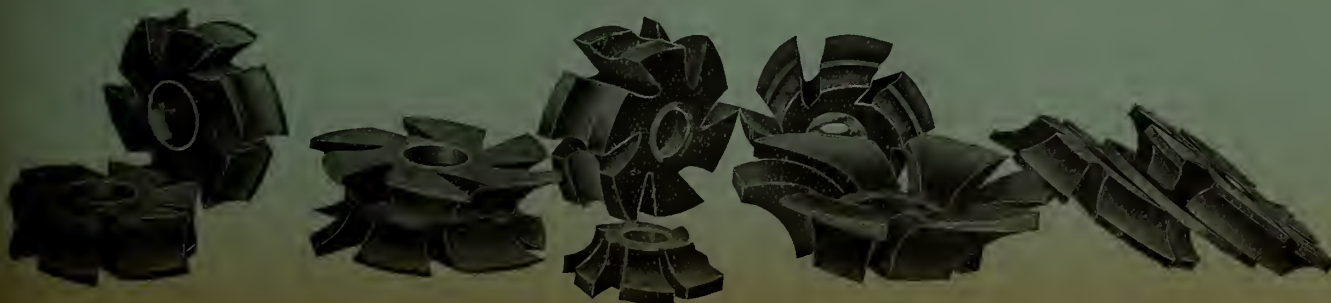

Furniture City Tool Company

189 CAMPAU STREET, GRAND RAPIDS, MICH., U.S.A.

AGENTS—
 Harron, Rickard & McCone, San Francisco, Cal.
 Schuchardt & Schutte, Berlin, Germany

HUTHER BROS. PATENT GROOVER OR DADO HEAD
For cutting any width groove from 1/4-inch to 2 inches or over

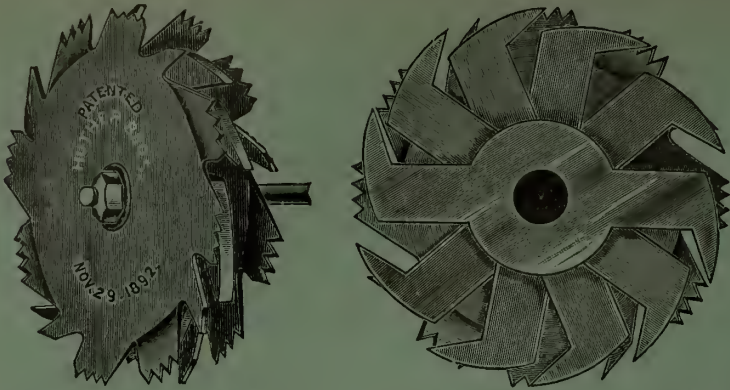

Can be used on any Circular Saw Mandrel. Will cut a perfect groove with or across the grain.

This is the only Dado Head on the market that gives entire satisfaction on all classes of work. No screw adjustment. For different width grooves, simply remove or add inside cutters. Sold by builders and dealers of woodworking machinery in all parts of the United States. Will send on approval, in competition with any other make on the market; if not the best return at our expense. HUTHER BROS., Platt Street, ROCHESTER, N.Y., manufacturers of Circular Saws, Morgan Pattern Lock-Corner Box Cutters, Concave Saws, etc.

Rice Lewis & Son,

Dealers in _____ LIMITED

BAR IRON AND STEEL

BOOM AND LOGGING CHAINS MADE TO ORDER

TORONTO

Write for Prices.

Steam, Power and Centrifugal Pumps, Condensers, Travelling Cranes.



Stock Carried in:

HALIFAX, MONTREAL, HAMILTON, WINNIPEG, VANCOUVER.

THE SMART-TURNER MACHINE CO., LIMITED
HAMILTON, ONTARIO

SEND FOR H.W. PETRIE'S MONTHLY STOCK LIST NEW & 2ND HAND MACHINERY TORONTO, CANADA

DO YOU USE Number 128 Tacks

ACTUAL SIZE

We make them, also Steel Log Hammers and Stamps, Brass Stencils and Stencil Inks.

HAMILTON STAMP & STENCIL WORKS, HAMILTON, ONT.

CRESCENT MACHINERY

Quality is all right. So's the price.

Band Saws Jointers Saw Tables

Very low price on BAND SAW BLADES Catalogue tells the rest.

H. W. PETRIE Dept. C. M. TORONTO, ONT.

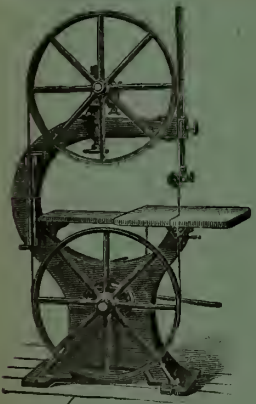

THE LEATHER BELT THAT'S KNOWN OUR "EXTRA"



MONTREAL WINNIPEG

TORONTO VANCOUVER

PINK LUMBERING TOOLS

The Standard Tools

In Every Province of the Dominion, New Zealand, Australia, Etc.



Pink Round Bill Peavey, Handles in Split Maple

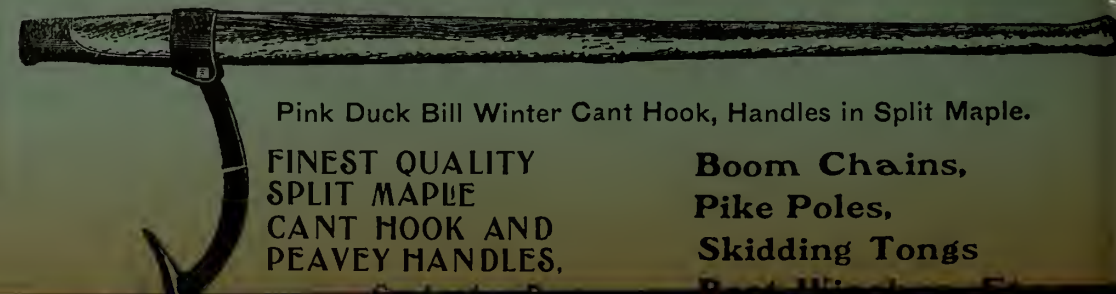

Pink Duck Bill Winter Cant Hook, Handles in Split Maple.

FINEST QUALITY SPLIT MAPLE CANT HOOK AND PEAVEY HANDLES,

Boom Chains, Pike Poles, Skidding Tongs

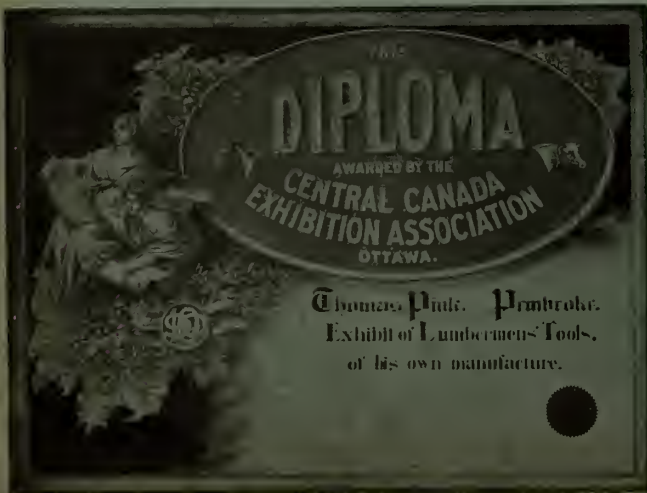

THOMAS PINK Pembroke, Ont.

THE CANADA LUMBERMAN AND WOOD-WORKER

VOLUME XXV. }
NUMBER 5.

TORONTO, MONTREAL — MAY, 1905 — WINNIPEG, VANCOUVER

{ TERMS, \$1.00 PER YEAR
Single Copies, 10 Cents.

LUMBERMEN'S LOG STAMPS
STEEL & RUBBER STAMPS, BRASS STENCILS, ETC.
THE SUPERIOR MFG. CO.
COR. BAY & ADELAIDE STS. TORONTO, CAN.
Write for Catalogue.

JNO. S. FIELDING, C. E.
WATER POWERS AND DAMS
Room 2, 15 Toronto Street - TORONTO

WIRE CLOTH

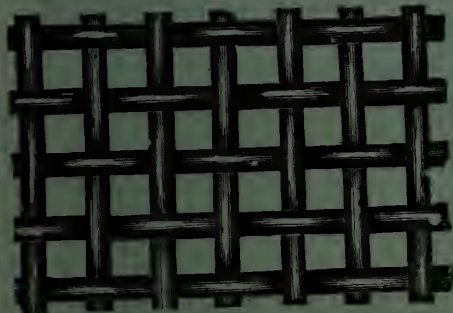

Special Heavy Steel Cloth for Refuse Burners, Smoke Stack Webs and Wire Cloth of every description.

THE **B. Greening Wire Co.**
LIMITED
HAMILTON, ONT. MONTREAL, QUE.

SANDVIK SWEDISH STEEL

The **Ottawa Saw Co.**
LIMITED
Middle Street, OTTAWA, ONT.

Sandvik Swedish Steel
Band, Gang and Circular Saws
P. M. FEENY, Manager.

OIL TEMPERED

Which is Wisest?

Some people buy belting on price, others on quality. Which is wisest?

J. L. GOODHUE & CO.,
DANVILLE, QUEBEC.

D. K. McLaren

GENUINE

Oak Belting

MILL SUPPLIES

751 Craig St., Montreal.

152 Bay St., Toronto.

WOODS LIMITED

.. Wholesale Manufacturers of ..

LUMBERMEN'S AND CONTRACTORS' SUPPLIES

INCLUDING

Tents, Flags, Awnings, Tarpaulins, Clothing, Overalls, Shirts, Mitts, Underwear, Blankets, Axes, Moccasins, Woods Celebrated Eider Down Sleeping Bags

WOODS BUILDING - OTTAWA, CAN.

SEND FOR **H. W. PETRIE'S**
MONTHLY STOCK LIST
NEW & 2ND MACHINERY
TORONTO, CANADA

DICK'S BELTINGS



Never is affected by wetness, and does not stretch

Excels in Transmission Power

Always Uniform.

LARGE STOCK ON HAND

WRITE TO SOLE AGENTS:

J. S. YOUNG, 14 Hospital Street MONTREAL

ALLIGATOR ROPES

And a Full Line of Hoisting and Haulage Ropes Carried

—IN STOCK—

W. H. G. Mussen & Co.,
MONTREAL

THE E. R. BURNS SAW CO.

TORONTO, ONT.

MANUFACTURERS OF HIGH-GRADE

Circular and Long Saws

UNEXCELLED

SHINGLE SAWS

OUR INSERTED TOOTH SAWS POSITIVELY THE BEST



The Wm. Hamilton Mfg. Co., Limited

Builders of a Complete Line of

SAW MILL MACHINERY

We are specialists in the building of sawmill machinery—we have been making it, and making it well, for nearly fifty years.

Surely our machines must have merit—must have lived up to all our claims, or we would not be in business to-day.

Back of every machine we sell is our guarantee against its failure due to defective material or workmanship, and our warranty of its successful operation.

All our machines are of simple design and enduring construction.

—

We are specially well equipped for handling repair jobs, and can give your orders prompt attention.

—

Can we not send you our catalogues?
Write Department L for them.

Our Line Includes

Engines and Boilers
 Band Mills
 With Weight or Steam Tension
 Gangs
 Carriages
 Husk Frames
 Log Handling Machinery
 Edgers
 Trimmers and Slashers
 Steam, Hand and
 Power Set Works
 Lath Mill, Shingle Mill
 and Filing Room Machinery
 Twin Circulares
 Tie Mills
 Burners

Head Office and Works : PETERBOROUGH, ONTARIO

Allis-Chalmers-Bullock LIMITED

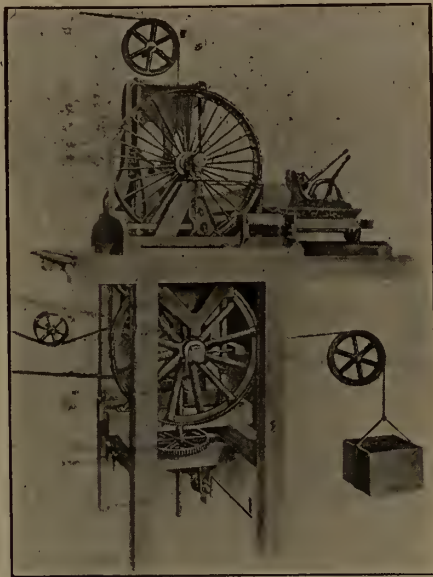

NEW ALLIS DOUBLE CUTTING TELESCOPIC BAND MILL

UP-TO-DATE SAW MILL MACHINERY

Builders in Canada of the Celebrated Machinery of Allis-Chalmers Co., Milwaukee; Bullock Electric Manufacturing Co., Cincinnati; Ingersoll-Sergeant Drill Co., New York; Lidgerwood Mfg. Co., New York.

WORKS : MONTREAL.

BRANCH OFFICES : HALIFAX, TORONTO, WINNIPEG, VANCOUVER, NELSON

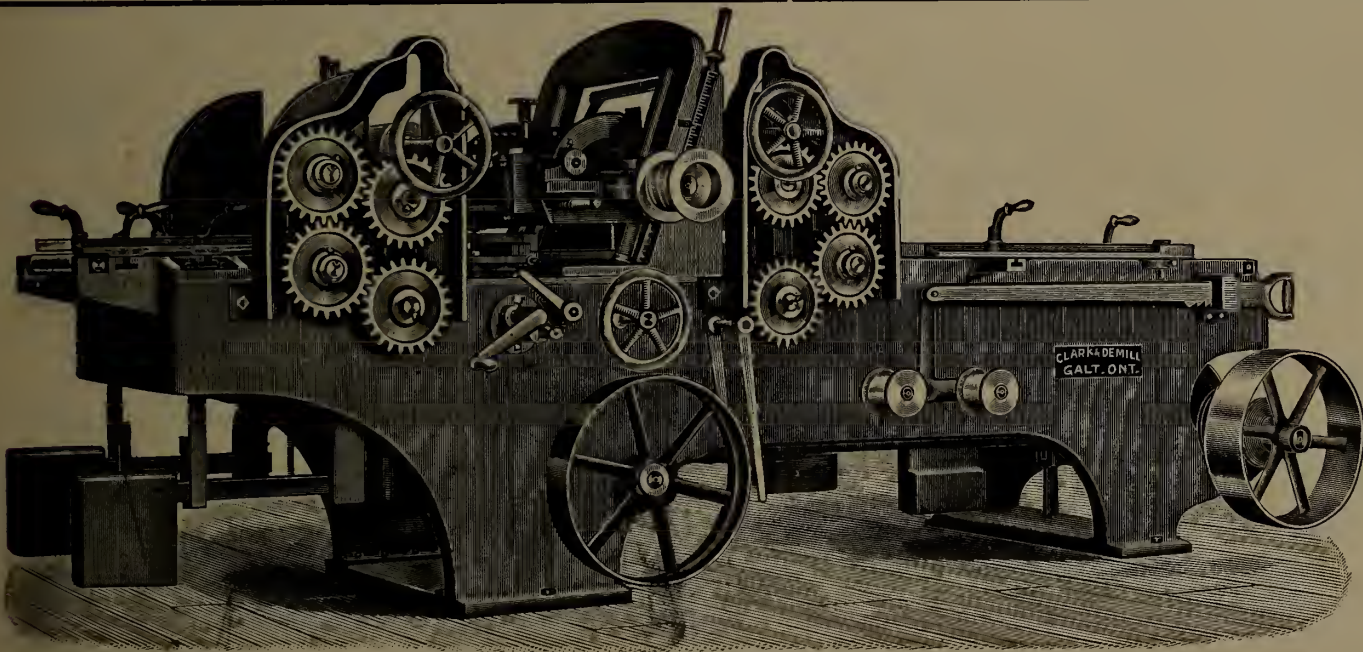

Our No. 72 LIGHTNING PLANER AND MATCHER

Kindly note that we make this machine in different sizes, single or double cylinder, as desired. Parties desiring thoroughly up-to-date machinery will find it to their advantage to write us before placing their order.

Write for new Catalogue.

Clark & Demill
Galt, Ont.

How About Wood Split Pulleys ?

When making your spring alterations in your mill you will doubtless require some Wood Split Pulleys. If you want to get the best wood split pulley manufactured to-day make your order read—

FAIRBANKS WOOD SPLIT PULLEYS

Study the cut. The web construction built in the rim not only strengthens the entire pulley but makes it impossible for the rim to work loose at the arm. Each segment is glued and nailed with three coated nails to the next one. Four point bushings are used, giving twice as much grip on the shaft as in the usual two point bushings. Write us.

THE CANADIAN FAIRBANKS COMPANY, LIMITED

MONTREAL

TORONTO

VANCOUVER

WINNIPEG



BRITISH COLUMBIA LUMBER AND SHINGLE MANUFACTURERS

The Canadian Pacific Lumber Co., Limited

PORT MOODY, B. C.

Manufacturers and Wholesale
Dealers in All Kinds of

B. C. LUMBER, LATH, MOULDINGS, ETC.

The Largest Shed and Dry Kiln Capacity of any Mill in British Columbia.
Special Attention Given to Orders from Manitoba and the Territories.



Long Distance
Telephone Connection.



Address the Company at Port Moody or
BYRNES & CUDDY, Selling Agents, WINNIPEG

CLOVERDALE MILLING CO., CLOVERDALE, B. C.

== Red Cedar Shingles ==

OUR SPECIALTY

SECOND TO NONE

CORRESPONDENCE SOLICITED

PETER LUND, Managing Director.

J. BRECKENRIDGE, President.

MANUFACTURERS OF
ALL KINDS OF

Grows Nest Pass Lumber Co., Limited

WARDNER, B. C.



BUILDING MATERIAL

Capacity 150,000 Feet Per Day.

THE KING LUMBER MILLS, LIMITED, CRANBROOK, B. C.

Manufacturers
of

Building Materials

And All Kinds of DIMENSIONS, FLOORING, CEILING and BASE and CASE MOULDINGS

Columbia River Lumber Company, Limited

HEAD OFFICE AT GOLDEN, B. C.

Largest Capacity in Mountains

MANUFACTURERS OF ALL KINDS OF

MILLS AT { GOLDEN, B. C.
BEAVER, B. C.
KAULT, B. C.
CARLIN, B. C.

ROUGH AND
DRESSED

LUMBER

FIR, SPRUCE
CEDAR AND PINE

LATH

Telephone Poles,
Piling, Etc., a
Specialty.

The Fernie Lumber Co., Limited, Fernie, B. C.

MANUFACTURERS OF AND DEALERS IN ALL KINDS OF

ROUGH AND DRESSED LUMBER

Dimension and Bridge Timber a Specialty.

Moulding in Stock or Made to Order.

JOS. GENELLE, Manager.

J. G. BILLINGS, Secretary.

THE YALE-COLUMBIA LUMBER COMPANY, LIMITED

Head Office: NAKUSP, B. C.

Mills at Nakusp, Westley and Cascade, B. C.

MANUFACTURERS OF

DEALERS IN

All Kinds Rough and Dressed Lumber,
Mouldings, Lath, Etc.

Cedar and Fir Piles, Telephone and
Telegraph Poles, Fence Posts, Etc.

North Star Lumber Co., Limited, Cranbrook, B. C.

Manufacturers
of

PINE, FIR and TAMARAC LUMBER

Specialty: Heavy Timber and Piling

BRITISH COLUMBIA LUMBER AND SHINGLE MANUFACTURERS

D. & J. HADDEN, CLOVERDALE, B.C.

MANUFACTURERS AND DEALERS IN THE HIGHEST GRADE

LUMBER AND RED CEDAR SHINGLES

Send your orders to the above firm, who can supply you with shingles that cannot be beaten for quality and prices.

Agent for Ontario : Woodstock Lumber and Manufacturing Co., Woodstock, Ont.



THE PIGEON RIVER LUMBER COMPANY PORT ARTHUR, ONT

MANUFACTURERS OF

Band Sawed White Pine Lumber, Lath, Pine and Cedar Shingles,

are operating their extensive plant night and day, to keep abreast with orders.

THERE IS A BECAUSE—

A trial order will tell you why.

Winnipeg Representative,

D. J. McDONALD, Clarendon Hotel.

J. A. SAYWARD

MANUFACTURER OF AND DEALER IN

Cedar and Spruce Lumber

Shingles, Lath, Spars, Etc.

ORDERS CAREFULLY EXECUTED
PROMPT SHIPMENTS

VICTORIA, B. C.

THE BRITISH COLUMBIA MILLS, TIMBER & TRADING COMPANY

Head Office : VANCOUVER, B. C.

Winnipeg Office : Merchants Bank Building P. O. Box 235

MANUFACTURERS OF

BRITISH COLUMBIA FIR, CEDAR and SPRUCE—both Rough and Dressed. Sash, Doors, Mouldings, Lath and the Highest Grades

“ROYAL CITY BRAND”

RED CEDAR SHINGLES

DOUGLAS FIR TIMBER

All Widths and Thicknesses up to 120 feet in Length Supplied on the Shortest Possible Notice.

OWNERS AND OPERATORS OF

HASTINGS SAW MILL - VANCOUVER, B. C.
ROYAL CITY SAW MILL, VANCOUVER, B. C.

ROYAL CITY SAW MILL, NEW WESTMINSTER, B. C.
MOODYVILLE SAW MILL - BURRARD INLET, B. C.

Total Capacity, 400,000 Feet of Sawn Lumber per Working Day of Ten Hours.

The Ladysmith Lumber Co., Limited

LADYSMITH, B. C.

Manufacturers of

LUMBER, LATH, SHINGLES,
MOULDINGS, ETC.

SPECIALTY: The best Cedar Shingles manufactured on the Coast.

FRESH WATER FIR LATH ALWAYS IN STOCK.

Capacity of Shingle Mill, 100,000 per day of 10 hours.

Correspondence Solicited

EAST KOOTENAY LUMBER CO., LIMITED

Capacity 150,000 feet per day.

Saw and Planing Mills at RYAN, CRANBROOK and JAFFRAY.

— WE MANUFACTURE —

TAMARAC PINE and FIR

FOR THE NORTH-WEST TRADE

Send us your orders if you want dry stock.

Head Office: CRANBROOK, B. C.

Mouldings

Shingles

VICTORIA LUMBER AND
MANUFACTURING CO., LIMITED
MILLS AT CHEMAINUS, B. C.

FIR AND GEDAR LUMBER

of all descriptions, in straight or mixed cars.

We can supply large and long timbers, but
don't care to ship anything over 40x40x140
feet long. : : : : :

Prompt Shipments
Good Quality and Manufacture
Long Lived Timber

ADDRESS—

CHEMAINUS, B. C.

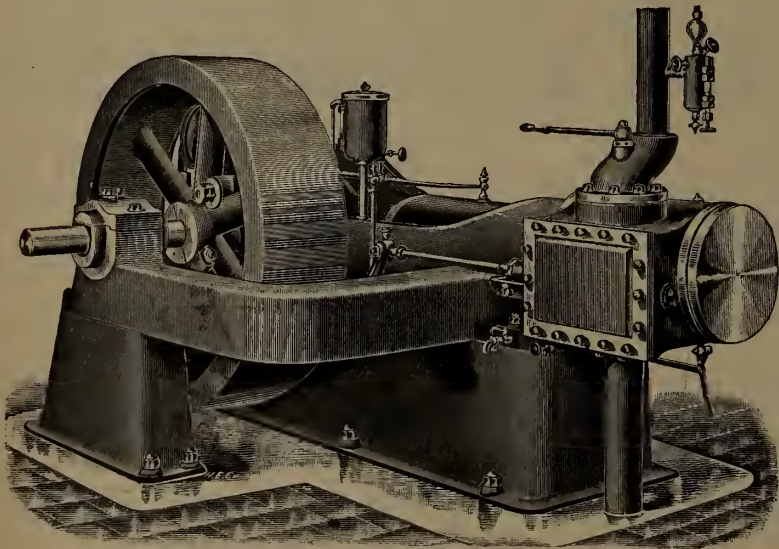

Our Engines are fitted with Automatic Governors
and run at Regular Speed, whether Loaded or Light.

They use about 25 Per Cent Less Steam than the
best engines with a throttling governor.

They are built on the Interchangeable System so
that duplicate parts exact in fit can be supplied at any time

In Sizes up to 125 Horse Power the outboard bearing
is attached to the frame, as shown in the cut, keeping it
perfectly in line.

ROBB ENGINEERING CO., LIMITED
Amherst, N.S.

D. B. GRANT.

T. W. KERR

DELTA SAW MILL CO.

MANUFACTURERS OF

Rough & Dressed Lumber, Lath, Shingles,
Fence Pickets, Doors, Sash, Mouldings,
Salmon and Fruit Boxes, and Round Tanks

Correspondence Solicited. - - LADNER, B. C.

The Manitoba Gypsum Co.

LIMITED

MANUFACTURERS OF

HARDWALL PLASTER WOOD FIBRE PLASTER
PLASTER OF PARIS STUCCO ALABASTER
and All Kinds of Gypsum Products

The Only Plaster Co. in Western Canada

Quality of goods superior to any imported article, our mill being equipped with the
latest improved machinery.

Dealers are invited to get our quotations before placing orders for Spring requirements.

Office: 811 UNION BANK BUILDING, WINNIPEG

D. E. ROBERTS

Lately in charge of the Plymouth
Plaster Co., at Fort Dodge, Iowa.
Superintendent of Manufacture

WM. MARTIN

General Manager

Gonnell & Dengler Machine Co.

ROCHESTER, N. Y.

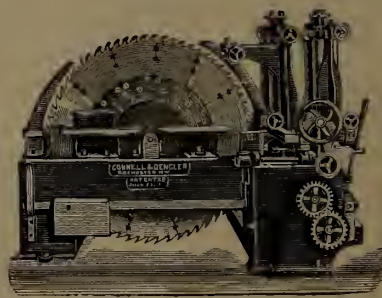

44 inch Circular Re-Saw.



60 inch Band Re-Saw

Manufacturers
of . . .

Box Makers' and
Planing Mill Machinery



Heavy 26 inch Divided Roll Planer and Matcher with 8 Feed Roll

Moreau's Pulpwood Barking Machine

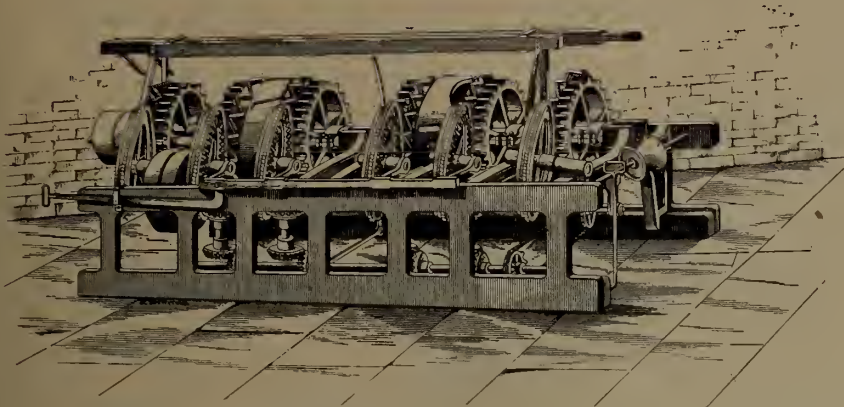

WEIGHT 4,200 LBS.

Latest and best Pulpwood Barking Machine. Requires about 7 h. p. to drive it full speed in work and one man can handle it and bark 22 to 30 cords of 4 foot wood per day according to average size of wood.

Wood is fed end on and any size from 3 to 24 inches, as the wood runs without loss of time between sticks. No long shavings and greatest economy in wood. Machines may be seen working any time. Write me for particulars.

R. S. P. SMYTH - QUEBEC, QUE.

Sole Agent for Canada

*P. O. Box 236
L. D. Phone 386*

THE E. LONG MANUFACTURING CO., ORILLIA, ONT.

THESE SAW CARRIAGES ARE MADE OF CAST STEEL, AND OPEN 36 TO 54 IN. FROM SAW.

We build Double Edgers, Steam Feeds, Log Jacks, Live Rolls, Trimmers, Slab Slashers, Steam Niggers.

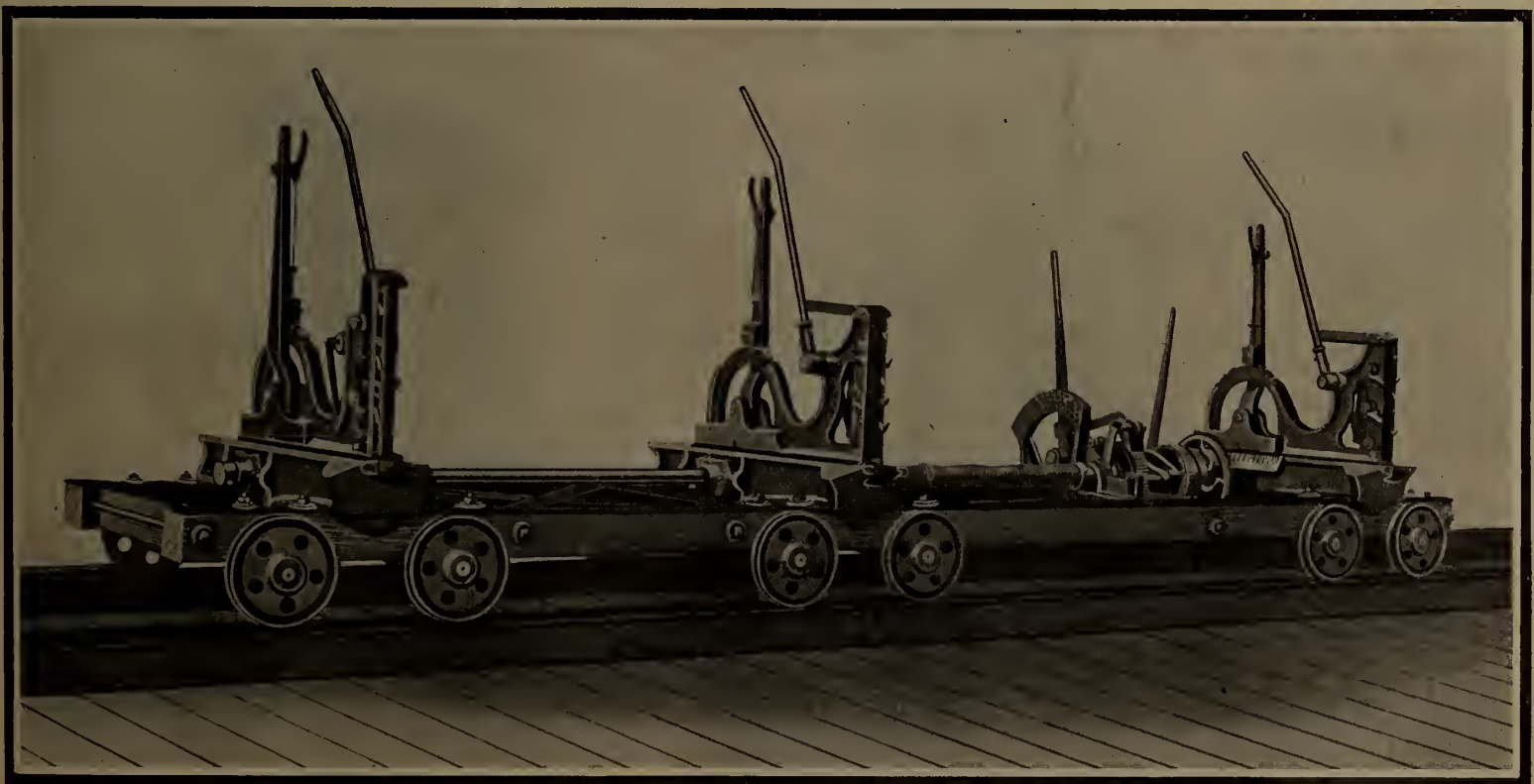

COMPLETE LINE OF SAW AND SHINGLE MILL MACHINERY
WRITE FOR CATALOGUE AND PRICES

**"DEFIANCE"
Wood-Working Machinery**

For Manufacturing
**HUBS, SPOKES, WHEELS, WAGONS,
CARRIAGES, RIMS, SHAFTS, POLES,
NECK-YOKES, SINGLE TREES, BARREL
HOOPS.**

Handles of Every Kind, insulated Pins, Spools,
Bobbins, Oval Wood Dishes, and General Wood-
Work.

Invented and Built by

THE DEFIANCE MACHINE WORKS,
Defiance, Ohio, U. S. A.

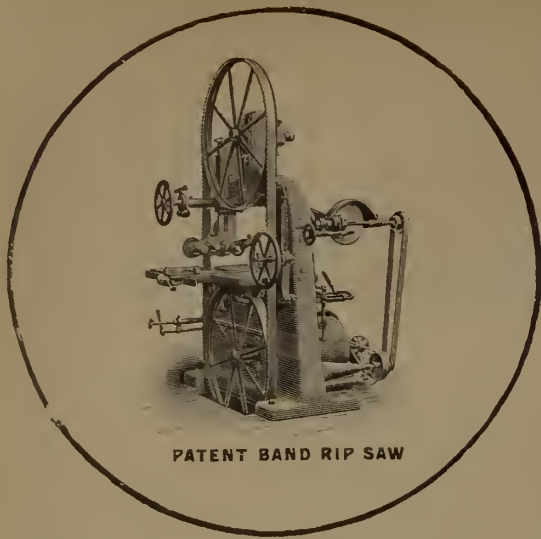

PATENT BAND RIP SAW

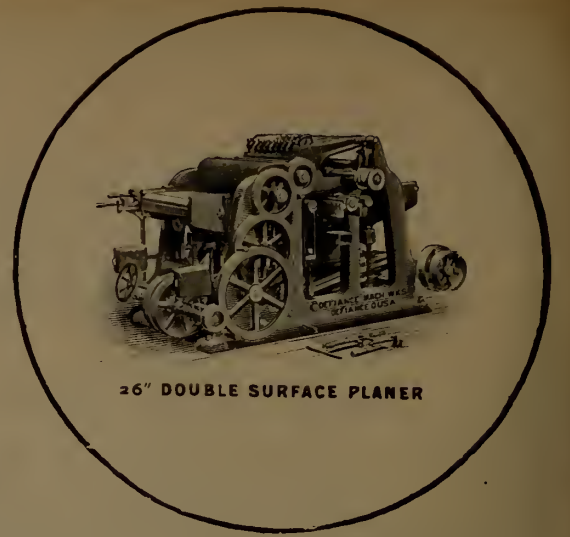

26" DOUBLE SURFACE PLANER

THE SCHAAKE MACHINE WORKS

NEW WESTMINSTER, B. C.

Builders of a Complete Equipmet of

Saw^{and} Shingle Mill Machinery

SOLE MANUFACTURERS OF

Johnson's Improved Upright Shingle Machines

**Pure Manila
Rope**

HIGHEST QUALITY MADE

British Manila

Sisal Rope

PURE SISAL

Lath Yarn

Wire, Write or Phone

**Canadian Cordage
& Manufacturing
Company, Limited**

Toronto, Ontario, Canada

Long Distance Phone 162.

Our Rope and Lath Yarn are Recogniz-
ed as the Best on the Market.



Cowan & Co. of Galt, Limited
GALT, CANADA

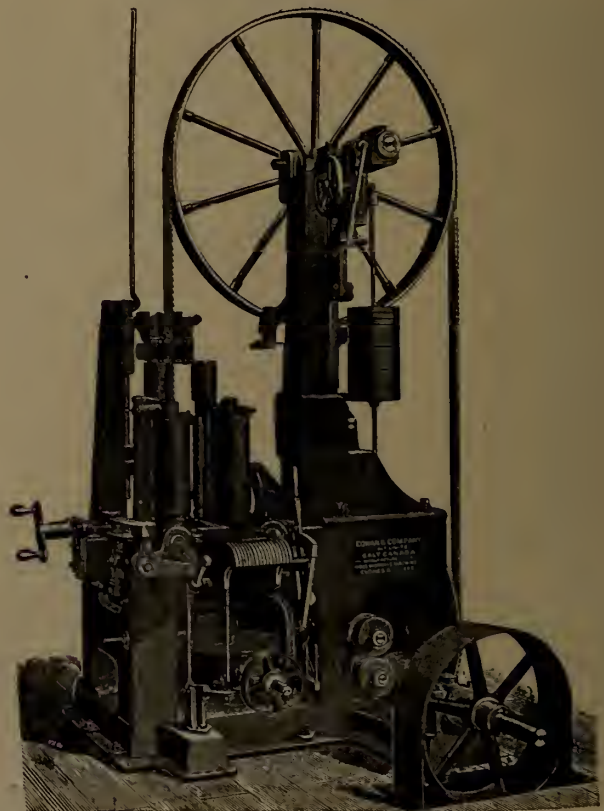

No. O Band Resaw, M167

We build this machine in different styles and sizes, with wheels 42", 48", 54" and 60" diameter. Also a full line of the most up-to-date Wood Working Machinery of superior material and workmanship.

Write for cuts and prices.

THE

MAPLE LEAF SAW WORKS



Shurly &
 Dietrich
 GALT, ONT.

Manufacturers of

- CIRCULAR SAWS
- GANG SAWS
- MILL SAWS
- BAND SAWS
- CROSS-CUT SAWS



Manufacturers of

- HAND SAWS
- BUCK SAWS
- PLASTERING TROWELS
- BUTCHER SAWS
- STRAW KNIVES, &c



GROUND THIN ON BACK
 Save Labor Save Gumming
 Save Time Save Files

This Saw Stands Without a Rival
 AND IS THE
FASTEST CUTTING SAW IN THE WORLD!

Its Superiority consists in its Excellent Temper. It is made of "Razor Steel," which is the finest ever used in the manufacture of Saws. We have the sole control of this steel. It is tempered by our secret process, which process gives a keener cutting edge and a toughness to the steel which no other process can approach.

Maple Leaf Saw Set

MANUFACTURED BY
 SHURLY & DIETRICH, Galt, Ont.

Directions.—Place the set on the point of tooth, as shown in the accompanying cut, and strike a very light blow with a tack hammer. If you require more set, file the tooth with more level.
 If you follow directions you cannot make a mistake. Be sure and not strike too hard a blow, and it will set the hardest saw. On receipt of 40 cents we will send one by mail.

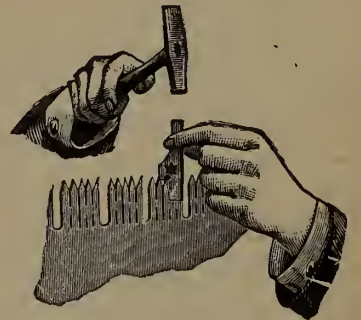

We are the only manufacturers in the world who export Saws in large quantities to the United States.

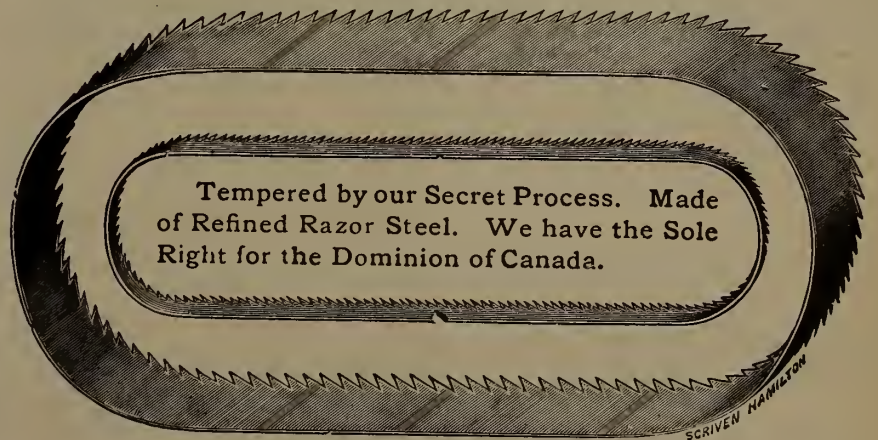

We Manufacture
HIGH GRADE BAND SAWS
 Of All Widths and Lengths.

These Saws are made of Refined Swedish Steel imported direct, and tempered by our Secret Process; for Fine Finish and Temper are not excelled.

CLASSIFIED INDEX OF ADVERTISERS

AXES	
Dundas Axe Works.....	12
Smart Mfg. Co., Jas.....	41
ALLIGATOR TUGS	
West & Peachey.....	47
BELTING	
Canadian Fairbanks Co.....	3
Gutta Percha & Rubber Mfg. Co.....	49
Goodhue & Co., J. L.....	1
McLaren, D. K.....	1
McLaren Belting Co., J. C.....	52
Sadler & Haworth.....	37
Waterous Engine Works Co.....	40
Wilby, P. H.....	12
Young, J. S.....	1
BUILDING BLOCKS	
Cement Building Block Co.....	40
BABBITT METALS	
Syracuse Smelting Works.....	34
BOILERS	
Canada Foundry Co., Limited.....	12
Dyment Foundry Co.....	44
John McDougall Caledonian Iron Works	36
DOORS	
New Century Refrigerator & Mfg. Co.	10
DRY KILNS	
Andrews Co., The A. H.....	51
McEachren Heating & Ventilating Co.	51
Sheldon & Sheldon.....	51
Standard Dry Kiln Co.....	51
ELEVATING AND TRANSMITTING MACHINERY	
Dodge Manufacturing Co.....	11
Perrin & Co., R.....	12
EMERY WHEELS	
Hart Corundum Wheel Co., Limited..	32
ENGINES AND LOCOMOTIVES	
Dyment Foundry Co.....	44
Gartshore, John J.....	10
Owen Sound Iron Works.....	49
Robb Engineering Co.....	6
EDGERS	
Gordon Hollow Blast Grate Co.....	47

GRATES	
Gordon Hollow Blast Grate Co.....	47
LUMBERMEN'S SUPPLIES	
Beal Leather Co., R. M.....	33
Capstan Mfg. Co.....	26
Garland, Son & Co., John M.....	38
Johnson, A. H.....	42
Long & Bro., T.....	38
Montreal Tent, Awning & Tarpaulin Co.....	
Merchants Rubber Company.....	40
Northern Elevator Co.....	41
Ontario Blanket Co.....	41
Park, Blackwell Co.....	40
Rice Lewis & Sons. Limited.....	52
Rutherford & Co. Jas.....	36
Thompson Mfg. Co.....	38
Turner & Sons, J. J.....	34
Woods, Limited.....	1

LUMBER AND SHINGLE MANUFACTURERS	
B. C. Mills, Timber & Trading Co.....	5
Cook & Bro. Lumber Co.....	40
Canadian Pacific Lumber Co.....	4
Cloverdale Milling Co.....	4
Crows Nest Pass Lumber Co.....	4
Columbia River Lumber Co.....	4
Delta Saw Mill Co.....	6
East Kootenay Lumber Co.....	6
Fernie Lumber Co.....	4
Hadden, D. & J.....	5
King Lumber Mills.....	4
Ladysmith Lumber Co.....	5
North Star Lumber Co.....	4
Pigeon River Lumber Co.....	5
Sayward, J. A.....	5
Victoria Lumber & Mfg. Co.....	6
Yale-Columbia Lumber Co.....	4

LUMBERMEN'S TOOLS	
Baldwin, Tuthill & Bolton.....	49
Burton Saw Co., A. J.....	48
Hay Knife Co., Peter.....	6
Pink, Thomas.....	52

MISCELLANEOUS	
Alexander Engraving Co.....	1
Bradstreets.....	10
Canadian Office & School Furniture Co. Limited	10
Denton, Dunn & Boulton, Barristers.	40
Fielding, J. S., Consulting Engineer..	1
Glenyards Fire Clay Co.....	45
Georgian Bay Engineering Works—Grinders.....	51
Huther Bros.—Dado Heads.....	52
Lumber Mutual Fire Insurance Co.....	39
McFarlane-Neill Mfg. Co.—Cant Dogs.	45

Marine Iron Works—Steamers.....	42
Manitoba Gypsum Co.—Plaster.....	6
Spence & Co., R.—Files and Rasps..	11
Sessenwein Bros.—Rails.....	33
Toledo Fire Insurance Co.....	35
Vogel, C. H.—Pulp Mill Engineer....	33

OILS	
Commercial Oil Co.....	40
Canadian Oil Co.....	26
Queen City Oil Co.....	11

PROVISIONS	
Eckardt & Co., H.P.....	31

PORTABLE SAW MILLS	
Drake, F. J.....	44
Owen Sound Iron Works.....	49

PLANERS AND MATCHERS	
Clark & Demill.....	3

PULLEYS	
Dodge Manufacturing Co.....	11

PACKING AND PIPE COVERING	
Garlock Packing Co.....	12
Purvis Co., E. L.....	45

ROPE	
Canadian Cordage Co.....	8
Consumers Cordage Co.....	39
Dominion Wire Rope Co.....	12
Greening Wire Co., B.....	1
Mussen & Co., W. H. C.....	1

ROOFING	
Bird & Son, F. W.....	34

RE-SAWS	
Cowan & Co.....	8

SAW SWAGES	
Hanchett Swage Works.....	33

SAW GAUGES	
Specialty Mfg. Co.....	12

STEAM BOILERS	
Canada Foundry Co.....	12
Owen Sound Iron Works.....	49

RAILS For Logging, Tramways, Switches Etc.
New and Second-Hand.
YARD LOCOMOTIVES
John J. Gartshore
83 Front St. West,
(Opposite Queen's Hotel.) Toronto.

R. SPENCE & CO.
Beech File Works.
HAMILTON, ONT.
FILE AND RASP MANUFACTURERS
AND RE-CUTTERS
A trial order solicited. Write for price list and terms.
C. P. MOORE, PROPRIETOR.

The . . .
QUEEN CITY OIL CO.
LIMITED

Head Office: TORONTO.

HIGHEST GRADES OF

Refined Oils
Lubrication Oils

AND ALL

Petroleum
Products

CANADIAN OFFICE & SCHOOL FURNITURE CO. LIMITED
PRESTON ONT.
FINE BANK, OFFICE, COURT HOUSE & DRUG STORE FITTINGS.
OFFICE, SCHOOL, CHURCH & LODGE FURNITURE
SEND FOR CATALOGUE

ESTABLISHED 1849.

BRADSTREET'S

Capital and Surplus, \$1,500,000.
Offices Throughout the Civilized World.

Executive Offices:

Nos. 346 and 348 Broadway, New York City, U.S.A.

THE BRADSTREET COMPANY gathers information that reflects the financial condition and the controlling circumstances of every seeker of mercantile credit. Its business may be defined as of the merchants, y the merchants, for the merchants. In procuring, verifying and promulgating information, no effort is spared, and no reasonable expense considered too great, that the results may justify its claim as an authority on all matters affecting commercial affairs and mercantile credit. Its offices and connections have been steadily extended, and it furnishes information concerning mercantile persons throughout the civilized world.

Subscriptions are based on the service furnished, and are available only by reputable wholesale, jobbing and manufacturing concerns, and by responsible and worthy financial, judiciary and business corporations. Specific terms may be obtained by addressing the company or any of its offices. Correspondence invited.

THE BRADSTREET COMPANY.

OFFICES IN CANADA: Halifax N.S. Hamilton, Ont. London Ont.; Montreal, Que.; Ottawa, Ont.; Quebec, Que.; St. John, N. B. Toronto, Ont. Vancouver, B.C.; Winnipeg, Man.

THOS. C. IRVING,
Gen. Man. Western Canada, Toronto



New Century Refrigerator &
Manufacturing Co., Limited
Dundas, Ont., Can.

Our Business is Manufacturing

**HARDWOOD
VENEER . . . DOORS**
With Built Up Bodies

These Doors are guaranteed not to warp or twist and are superior in construction and finish to any other Door on the market.

Send for Illustrated Catalogue and Prices.

Special attention given to Architects' Designs of Doors and Trims.

AGENTS WANTED EVERYWHERE.

ADDRESS DOOR DEPARTMENT

Chain and Sprockets



**We Carry an Immense Stock
for Quick Shipment!**

DODGE MANUFACTURING CO.

TORONTO

MONTREAL

THE TURIMPH TURBINE



Is the most powerful wheel on the market to-day. A glance at this cut of the centre shows that the buckets are designed to secure the **maximum of speed** with **great power** and a **free discharge**. Mr. E. S. Edmondson, of Oshawa, writes as follows under date of November 16th, 1903, regarding a 26 inch Vertical Triumph Wheel:

“The Wheel is strictly first-class in every particular, and after a careful and thorough test I am prepared to say that I believe it is the best wheel in the market for Electrical purposes. It has high speed, large power, high efficiency at part gate, and has practically no leakage. I am more than pleased with the thorough and workmanlike setting you gave me throughout.”

For horizontal settings in large Pulp Mills, Cement Mills or Electric Power Developments this Wheel has no equal. We invite your enquiries. Large catalogue to be had for the asking.

We are always glad to submit estimates and prices on **Improved Vulcan and Leffel Turbines, Improved Lane Circular Saw Mills, Edgers, Trimmers, Slashers, Shingle Machines, Lath Machines** and all machinery of this kind.

MADISON WILLIAMS

H. E. PLANT, Agent
Cor. Common and Nazareth Streets
Montreal, Que.

Successor to Paxton, Tate & Company
PORT PERRY, ONT.

Manitoba Iron Works
Western Selling Agents
Winnipeg, Man.

TEON BELTING



STEAM PROOF
 WATER " "
 HEAT " "
 OIL " "
 ACID " "
 Stronger and Cheaper than
 Leather.

LEATHER BELTING
 CAPATA BELTING [BALATA TYPE]

CAMELS HAIR BELTING
 LACE LEATHER, ETC.

Special Arrangements for Trial Belts.
 Write for Price Lists and Discounts.

P. H. WILBY, 27 1/2 Front Street East, TORONTO
 Phone Main 1930. SOLE AGENT FOR CANADA.

Dundas Lumberman

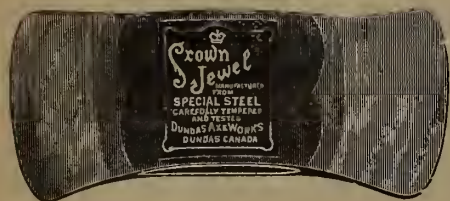

A New Axe tempered by a new process which enables us to submit to any lumberman three or more samples of Axes, all different degrees of hardness, and on a selection being made we will guarantee to furnish any number all exactly the same temper as sample chosen.

THE DUNDAS AXE WORKS
 Dundas, Ont.

LARGE STOCK CARRIED & CUT TO ANY LENGTH
 BLOCKS, CLIPS, TURNBUCKLES, ETC.

WIRE ROPE

SPECIAL ROPES FOR LUMBERING
 DOMINION WIRE ROPE Co., LTD
 MONTREAL, QUE.

EVERY LUMBERMAN WANTS IT — 35 cents buys it
Scribner's Lumber and Log Book

BRIMFUL OF EVERY-DAY
 PRACTICAL INFORMATION

Address :
 THE CANADA LUMBERMAN, Toronto

STEAM BOILERS

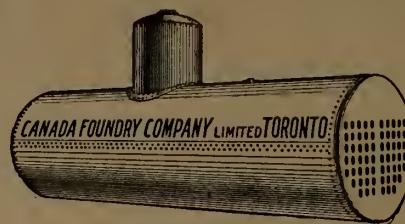

Portable Boilers—Locomotive Style
 Return Tube Tubular

Tanks, Water Towers, Smoke Stacks, etc.

CANADA FOUNDRY COMPANY, LIMITED
 Head Office and Works: TORONTO, ONT.

District Offices: Montreal Halifax Ottawa Winnipeg Vancouver Rossland Calgary

Detachable Chain Belt

—AND—

CONVEYING

MACHINERY



William R. Perrin & Company
 Limited

TORONTO, CANADA.



WOODWORKERS SAY

"The convenience to the Sawyer and the saving in lumber make the STANDARD AUTOMATIC SAW GUAGE an article of much merit."

WRITE TO
 SPECIALTY MFG. CO.
 DETROIT
 Mich.

Garlock Packing Co.

HAMILTON - - - CANADA

—SOLE MANUFACTURERS OF—



GARLOCK'S PACKINGS

PATENTED

Asbestos and Mineral Wool Pipe and Boiler Coverings, Engineers' Supplies in General



THE CANADA LUMBERMAN AND WOOD-WORKER

VOLUME XXV.
NUMBER 5.

TORONTO, MONTREAL, WINNIPEG, MAY, 1905

TERMS, \$1.00 PER YEAR
Single Copies, 10 Cents

THE LUMBER CAMPS IN THE UPPER OTTAWA VALLEY

The lumber output in the Ottawa Valley promises to be much smaller than last season, owing to the fact that four firms which operated last season have suspended operations this year. They are:

R. H. Klock & Company, Ottawa, 2 square timber camps.

The Hull Lumber Company, Ottawa, 4 log camps.

Edward Moore, Ottawa, 2 square timber camps.

Estate Late Robert Hurdman, Ottawa, 5 log camps.

The unusual depth of snow so early in the season also had the effect of causing a majority of the firms to suspend their cutting opera-

manufacture at Braeside, Ont., have four camps situated up around the head of Lake Temiscamingue, Montreal River and Quinze district. Their headquarters for the district are at Villa Marie, Que., where Mr. Riddell, their book-keeper, is stationed, while the camps are under the able supervision of Mr. D. Carmichael.

At the head of the lake we find the Hawkesbury Lumber Company, whose mills are at Hawkesbury, Ont., with two camps. Their headquarters are at North Temiscamingue, and Mr. D. Lunam, their agent, keeps a watchful eye over their interests.

Coming on down to the foot of the lake and situated below and along the Ottawa river, the

large camps, compared with four last season. Their manufacturing is all done at their mills in Ottawa, where their Canadian manager, Mr. Peter Whelen, has charge. Their logging operations are in charge of Mr. John McCulloch, who is one of the most experienced agents on the Ottawa river, while their book-keeper is Mr. Frank French.

The Estate of A. Lumsden have one large camp on McKenzie Island, in charge of Mr. McElroy. Their drive is comparatively short, as their mill is situated on Gordon Creek.

McLachlan Bros., of Arnprior, Ont., have five camps in the Brennan Lake district, emptying into the Kippewa Lake at the head. Their general up-river manager is Mr. J. Burwash, one of the most experienced in his line on the Ottawa. At this branch Mr. Jos. Gaudette and Mr. James Byrnes ably look after the agency and book-keeping end of the business.



MORIN'S CAMPS, FRASER & COMPANY, JOCKO RIVER.



B. HENNESSY'S CAMP, J. R. BOOTH, ON L'AMABLE DU FOND.

tions earlier than other years and to devote the balance of the season to hauling logs already cut.

There promises to be any quantity of water for the drives, and the Upper Ottawa Improvement Company, who have the contract for driving, sorting, booming and delivering logs at the mills between Ottawa and Lake Temiscamingue, are busy, at time of writing, over-hauling their fleet of steamers, tow-boats, tugs, alligators and scows, and getting ready for the spring, which from present indications will be somewhat earlier than last year.

On Lake Temiscamingue, the well known firm of J. R. Booth, with mills at Ottawa, has two large camps at Old Mission Point. They are under the capable management of Mr. E. Hennessy, while Mr. W. H. Rice is depot book-keeper. Mr. J. W. Hennessy, who by his ability has been promoted to the important position of general up-river agent, also visits this branch together with the L'Amble du Fond, Coulonge, Schyan, Indian Lake, Rainy Lake and Condo branches.

The Gillies Bros. Company Limited, who

Hawkesbury Lumber Company and the W. C. Edwards Company have five camps. Their headquarters are at Beauchene, Que., on the Gordon Creek branch line of the Canadian Pacific Railway, where Mr. Morrison, their book-keeper, is located. Their manager in charge is Mr. Geo. Rochester, whose ability as a manager is well known to everyone.

The Upper Ottawa Improvement Company have a fleet of tow boats on the lake, and take charge of all logs belonging to the above mentioned firms immediately on their being boomed out of the creeks and rivers. The Lumsden line of steamers plying between Gordon Creek, Villa Marie, New Liskeard, Haileybury, North Temiscamingue, White River and intermediate points, handle the bulk of freight and passenger traffic, but a considerable amount comes over the Government railway built from North Bay, which strikes the lake at New Liskeard.

In the Kippewa district the Shepherd & Morse Lumber Company, with head offices in Boston, U. S. A., are increasing their output over last year. This season they have five

Owing to the distance from their mills the firms operating in this district have their driving operations considerably shortened by two artificial canals—one is called Turtle Portage, connecting North River with Kippewa Lake. The distance between the two lakes being only about 150 yards, and North River level being about 15 feet above Kippewa, a canal 20 feet wide was constructed and provided with a dam and gates across the head to regulate the flow of water. The logs are all taken down this way, saving a distance of about 18 miles, which on a large lake with bad winds for towing purposes is quite an item. Alongside the canal a small tramway is built with a large freight shed at each end, and freight is transported across in this way from one steamer to the other.

Gordon Creek, emptying into Lake Temiscamingue from Lake Kippewa, is practically the same as Turtle Portage only on a much larger scale, being about 8 miles long, although it is not altogether artificial, but as the creek has been excavated, side piers built and otherwise improved in many different ways, possibly it might be called artificial.

Emptying into the Ottawa River at Seven League Lake is the Jocko River, and while only a small tributary of the mighty Ottawa, still for rapids, chutes and roughness in general, in proportion to its size, it leads all the other streams. It was considered impossible to drive logs or timber, and in fact some firms operating on it were obliged to haul their timber a distance of about 20 miles to the Ottawa River, but Fraser & Company, who are this season operating five large camps, have succeeded in overcoming all obstacles, and have built a chain of improvements in the shape of side piers, rolling dams, slides, etc., from the mouth almost to the source. Their drive last year was out early in May, which owing to the lateness of the season was considered extremely early. Their mills, which are practically new and up to date, are situated at Deschene Rapids, a distance of about seven miles from Ottawa. Their up-river manager is Mr. Geo. B. Campbell, whose reputation as an estimator of standing pine is second to none, while at Jocko River Depot Mr. William Burns has charge of all book-keeping and supplies.

Further on down and emptying into the Mattawa River above Mattawa, the L'Amble du

on the Ottawa, needs no introduction to the readers of THE LUMBERMAN. The senior member, the Hon. Peter White, at present represents North Renfrew constituency at Ottawa and was Speaker of the House during the last Conservative administration.

The Dumoine river is one of the larger tributaries of the Ottawa, and empties in above the famous Des Joachims Rapids. Its main head is Big Lake Dumoine, a large lake about 20 miles long in some places. A large number of streams empty into this lake also, and the river is fed by a like number of smaller streams. Lumbering on the Dumoine is on the decline and this year but two firms are operating, where some years ago somewhere in the neighborhood of eight or nine firms were running at their full capacity.

The E. B. Eddy Company have three camps situated around the shores of Big Lake Dumoine under the capable management of Mr. R. E. McCracken, one of their oldest and most trusted employees. Their headquarters for this branch are at Stubbs Bay, where they have a fine depot under the management of Mr. Chas. Mangan, who looks after the book-keeping as well.

On the Ontario side of the Ottawa emptying in at Petewawa, about 15 miles above Pembroke and extending for over 100 miles west, is the Petewawa River, a second Ottawa, and in many places larger than the Ottawa.

Up almost at the source McLachlan Bros., of Arnprior, have four large camps, under the management of Mr. J. McManus. Their headquarters are about 12 miles from Brule Lake on the line of the Canada Atlantic Railway, where Mr. Robert I. Duff, their book-keeper, is stationed.

Coming on down to Cedar Lake and vicinity, the Hawkesbury Lumber Company have four camps this season, under the watchful supervision of Mr. John Kennedy. Their headquarters are at Halfway, a distance of 15 miles from Deux Rivieres, by which route the mail and supplies are brought in. Mr. H. S. Brook looks after all supplies and book-keeping at this point.

On the South Branch Mr. J. R. Booth has two large camps under the management of Mr. R. Booth, of Pembroke. His assistant is Mr. Archie McAdam, of Quyon, Que., who does all the book-keeping and receiving of supplies.

Black River on the Quebec side is another



TURTLE PORTAGE CONNECTING NORTH RIVER AND KIPPEWA LAKE.



MILLAIRE'S CAMP AND CREW, SHEPARD & MORSE LUMBER CO., KIPPEWA, QUE.

Fond River runs. This stream, which is quite a size, has only one firm operating on it, Mr. J. R. Booth, who has three large camps of logs and pulp wood. The limit is known as the famous Mackey limit, and was owned and operated for years by the late Mr. Mackey, of Ottawa, for square timber purposes. This one of Mr. Booth's many branches is capably managed by Mr. Geo. Purdy, while Mr. J. A. Neil is book-keeper, with headquarters at Eauclaire.

At Klocks Mills Mr. Thomas Carpenter, for years agent for McLachlan Bros., has gone into lumbering on his own account, and has a large contract of spruce and pulp for Mr. J. R. Booth's large pulp mill at Ottawa.

Deux Rivieres further down the Ottawa has another contractor in the person of Mr. A. Thrasher, who has a large contract for the Shepherd & Morse Lumber Company and who operated two large camps this season. Mr. Thrasher does his own superintending, while Mr. E. R. McColgan looks after the interests of the Shepherd & Morse Company in the matter.

On Bear creek, another small tributary of the Ottawa emptying in above Rockcliffe, the firm of A. & P. White have three camps under the able management of Mr. George Reilly, of Pembroke. The firm being one of the oldest

Down at Rowanton, a distance of about 20 miles from Des Joachims, the Hawkesbury Lumber Company have their Dumoine Depot, which is considered one of the finest on the Ottawa. This branch is under the able supervision of Mr. John McElroy, who had four large camps this season. Their book-keeper is Mr. Gerald Fitzgerald.

At Deep River below Des Joachims on the Ottawa and Chalk river, on the C. P. R. line, the lumber operations are carried on by Fraser & Company, who have several camps. Their drive at this branch will be particularly short, as a quantity of their logs are laid on the Ottawa and the balance on creeks about 15 miles from the river. This branch is under the management of Mr. Geo. E. Campbell, who is ably assisted by Mr. Alfred Allen, of Point Alexander.

Coming further down to Schyan Point, we find where the Schyan River and Ottawa join their forces. On this stream, once largely operated by the Bronson & Weston Lumber Company, of Ottawa, Mr. J. R. Booth has three large camps, in charge of Mr. Dwyer Hennessy, another one of his very capable overseers with headquarters at Schyan Farm. At this point Mr. John Lister, the book-keeper, is also stationed.

large stream noted for its rough nature. It extends over 100 miles due north and has its source in the same region as the Dumoine, Coulonge and Gatineau Rivers.

The W. C. Edwards Company, who manufacture both at Ottawa and Rockland, Ont., have four camps situated at different points. They are carefully looked after by Mr. Robt. Ralph, with head-quarters at Black River Depot on Lake St. Patrick, where Mr. James Leslie, the book-keeper, is also stationed.

Further up, McLachlan Bros. have five large camps, on what was formerly known as the Fraser limit, and purchased by them from the late Alexander Fraser. Their camps are under the management of Mr. D. McGregor, another of their very capable agents, who has headquarters at Lake Traver Depot. Their book-keeper is Mr. Alex. Taylor.

Mr. John Ostrom, of Pembroke, has a large log contract with Mr. J. R. Booth and has been operating two camps for the past season. Mr. Ostrom does considerable contracting in the Sudbury district and has a thorough equipment of all logging and driving rigging himself.

The Coulonge River is probably the most operated upon of any stream in the Ottawa Valley to-day, and this season it will contribute at a low average over three-quarters of a

million pieces, and possibly a million. Six firms operated heavily, with a total of 24 camps, and judging by the quantity of supplies which have been put in to start them another season, next year the output will probably be larger.

The Gillies Bros. Company, of Braeside, operated seven large camps on what is known as the famous Perley limit purchased by them from the firm of Fraser & Company. On their Osborne limit on the East branch they have a number of contractors also. These camps are all under the supervision of Mr. Robt. Moorhead, of Bryson, who is well known all through the Ottawa Valley as one of the most energetic agents in the business. The headquarters are Perley Depot, where Mr. A. Mc-



LOG GANG, LUDGATE'S CAMP, ST. ANTHONY LUMBER COMPANY, WHITNEY, ONT.

Nab receives all supplies, manages the depot and does the book-keeping.

At the head-waters of this stream the East Templeton Lumber Company, of East Templeton, where their mills are situated, and which was formerly known as the firm of McLaren & McLaurin, and latterly the estate of the late John McLaren, operated three large camps. Situated as they are at the height of land and in a country which is a chain of lakes varying from one mile long to twenty, and where the waters flow to the Ottawa, Black

their hauling, they kept their cutting staff on, as the snow was not much more than 24 to 30 inches deep, while in other places $3\frac{1}{2}$ and 4 feet of snow were recorded.

On what is known as the Mason limit the E. B. Eddy Company, Ltd., have two camps. They are under the management of Mr. Geo. B. Klock, while Mr. John Steele is book-keeper.

Further down we come to Mr. J. R. Booth's Indian Lake Branch, where he operated two large camps of logs and spruce. They were under the management of Mr. Dwyer Hennessy, while Mr. Andrew Neville looked after all supplies and book-keeping.

On the opposite side of the river is the new branch opened up last year and which is known as the Condo. This is the branch where, after shutting down the Dumoine branch, all equipment was moved to. Supervised over by one of his oldest and most experienced agents, Mr. Jos. Taylor, he had three large camps going all season. Mr. E. Labelle had charge of all supplies and book-keeping at this particular branch.

Still following on the chain of Mr. Booth's limits, we come to another branch known as the Coulonge branch, with headquarters at Jims Lake Depot, a distance of 28 miles from Fort Coulonge. Mr. Pounder is stationed here and receives all supplies besides doing book-keeping for two large camps, which were under the management of Mr. Dwyer Hennessy.

At the head waters and almost on a parallel with the East Templeton Lumber Company, Fraser & Company operated three large camps, under the management of Mr. W. N. Vaughan, whose reputation as a river and woodsman is well known to everyone. Although situated on the Coulonge River, the firm haul all supplies and mail and take their men in by the Dumoine route and across over to their headquarters at White Depot, where their book-keeper, Mr. Geo. E. Fumerton, is stationed.

During the last few years the firm of Davidson & Thackeray, of Ottawa, finding their business growing to such proportions, purchased a limit on what is known as Moose Lake, a distance of about 15 miles from Fort Coulonge. They then erected a large mill at Fort Coulonge, where all their lumber is cut and then shipped to their factory in Ottawa, where it is manufactured into

all kinds of dressed lumber. Their camps, which amounted to two large ones, were ably looked after by Mr. James G. Bryson.

Leaving the Quebec district, we will cross over to Ontario, to what is known as the Nipissing region. Again we strike Mr. Booth's operations, where he has two square timber and two log camps. This is known as the Rainy Lake branch, and all men and supplies are brought by the Canada Atlantic Railway

to Rainy Lake, where headquarters are.

Superintending the operations here is Mr. A. G. Smith, who together with Mr. J. C. Gaudiet, book-keeper, looks carefully after the firm's interests.

On the line of the Canada Atlantic Railway at Whitney, the head of the Madawaska and Opongo waters, the St. Anthony Lumber Com-



G. FITZGERALD BOOK-KEEPER HAWKESBURY LUMBER COMPANY, DUMOINE, QUE., AND PET MOOSE.

pany have built one of the finest and most up-to-date mills in Canada. They operate two large camps on the Madawaska waters, driving their logs down to Long Lake to where their mill is situated. Their other camps are situated on Big Opongo Lake, and as the water runs directly away from their mill, they were obliged to construct a railway branch from their mill a distance of about 15 miles. This line is operated all summer hauling logs from the Opongo Lake, where they are all boomed and towed down to the loading point, and dumped into Long Lake, where the mill is situated. Their head office is in Ottawa, where their manager, Mr. E. C. Whitney, resides. In full control of all logging operations is Mr. Jas. McKinnon, whose long lum-



LOGS READY FOR THE MORNING, ARDILL'S CAMP, GILLIES BROS. COMPANY, COULONGE.

ber experience on the Ottawa ably fits him for such a responsible position. Mr. Labelle, the book-keeper, has his headquarters in Whitney, where the mills are situated.

Situated at Madawaska, a divisional point on the Canada Atlantic Railway, we come to another one of Mr. Booth's many branches, the Egan Estate Branch. This is the railway branch where five large camps are operated and all logs and timber are railed by the Canada Atlantic Railway (which by the way was built and owned by Mr. Booth also) to his mill at Ottawa. Several band saws are kept running all winter after navigation is closed and logs are frozen in, giving employment to hundreds of men during the winter season.

So closely is Mr. Booth in touch with his camps that a telephone is installed in No. 1 Camp, where his manager, Mr. W. G. McKay, makes his headquarters, and where he can communicate with him at any time. He also operates a large store and post office at Madawaska, where the book-keeper, Mr. Geo. B. Hamblin, looks after matters pertaining to his department.



FELLING PINE IN ONTARIO.

River and Gatineau, their drives are out remarkably early, and great credit is due their agent, Mr. John Kealey, for the very successful way in which he manages them. Mr. W. P. Regan is the book-keeper. During the past season this firm was particularly fortunate in not having to contend with very deep snow, and while other firms much lower down were obliged to suspend their cutting operations and were considerably later than last year with

REVIEW OF THE CAMP SUPPLY TRADE

Labor More Plentiful During the Past Year, but Supplies Generally Were Higher in Price.—Cost of Producing Lumber Still Very Great.

It is probable that the log production of the past winter was secured at a slightly lower cost per thousand feet than in the previous season, the remuneration for labor being responsible for this saving. The difference between the wages paid the past winter and those of 1903-4 cannot all be classed as a saving, for provisions and supplies generally were more costly.

The policy of curtailment which was decided upon last summer by lumbermen in almost every province of the Dominion greatly influenced the labor market. The depressed condition of the lumber trade in British Columbia, where many of the largest mills were closed down for several months, had a tendency to keep wages within reasonable bounds. The wages which had been ruling in Ontario and Quebec were regarded by the lumbermen as too high, and at a meeting held in July last a resolution was adopted agreeing to a scale of wages of from \$16 to \$28 per month and board. On account of the lighter operations, work for the lumber jacks was less plentiful, and most of the firms succeeded in obtaining a sufficient number of men at the scale agreed upon. The average wages for the season was about \$26 for axemen, as compared with \$30 to \$32 in the previous winter. Teamsters were paid \$30, which was \$5 less than in the season of 1903-4. These wages also ruled to a large extent in the Maritime Provinces.

"Jumpers" were a less frequent cause of annoyance the past winter. Apparently, the punishment inflicted upon some of the offenders has been effective in mitigating the evil. Most of the operators adopted a stringent form of agreement to be signed by the workmen, which, among other things, provides that no allowance of time will be made to the men while off work during inclement weather.

It is not anticipated that there will be any advance in the wages of woodsmen for the coming season, although as the hiring of men will not commence for a couple of months, it is yet too early to speak with assurance. If the volume of operations should be materially increased, it would probably be reflected in a higher labor market.

GROCERIES AND PROVISIONS.

Prices of supplies for the lumber camps, such as barrelled beef and pork and general provisions, are on a higher basis than one year ago, when lumbermen were able to purchase their supply of pork in particular upon very favorable terms and at a decline of about \$6 per barrel as compared with the spring of 1903. There has been a natural reaction from this low price. The advance has been about \$1 on barrelled beef and pork, 30 cents on mess pork, and 50 cents per cwt. on live hogs. Current prices in Toronto on packing house products

as compared with the corresponding time in 1904 are as follows:

	1904	1905
Shortcut Pork.....	\$17.00	\$19.50
Shoulder Shortcut.....	15.00	16.00
Heavy Mess Pork.....	15.00	16.00
Long Clear Bacon.....	8	9½
Short Clear Middles....	7½	8
Medium Smoked Hams..	12 to 12½	12 to 13½
Heavy Smoked Hams...	10 to 11	10½ to 12
Smoked Breakfast Bacon	12½	12 to 13½
Lard, tierces.....	8 to 8½	9 to 9½

The trade conditions in general seem to be quite satisfactory and the packers look for a continued good demand at prevailing prices.

The inflated prices which have ruled for wheat during the past year have been responsible for an advance in the value of flour. As compared with a year ago, prices are nearly one dollar per barrel higher. It is doubtful, however, whether these prices will hold, as the winter wheat crop is progressing very favorably, and, given satisfactory growing weather during the next two months, an abundant yield will be assured.

Taking the general line of groceries, prices are somewhat higher than one year ago. Such articles as sugar, molasses, dried apricots and peaches, canned tomatoes and white beans show a substantial advance, sugar representing the greatest increase. The present wholesale price of No. 1 yellow sugar is about \$5, as compared with \$3.65 in the spring of 1904. This commodity still shows an upward tendency, as recently two of the Canadian refiners advanced their prices. The latest European cables indicate a firm and higher market for beet sugar. Cuba, which earlier in the season was expected to give a crop of 1,200,000 tons, reports that developments are such that the production will fall 100,000 tons short of this figure.

Prices of syrups have remained almost stationary, but in some kinds of molasses fluctuations have been very wide during the past twelve months. The price of West India molasses, for instance, is to-day 12 to 14 cents per gallon higher than it was a year ago. Whether or not these extreme prices can be maintained it is difficult to say, though all reports indicate a short crop throughout the West Indies. It is the opinion of the importers, however, that this grade of molasses is above its market value and that unless prices recede the consumption will be much less than it would be at a more normal figure. The cheaper grades of molasses have not advanced as much as the Barbados product, but the grades usually used in the lumber camps are worth from five to ten cents per gallon more than they were last spring and are likely to continue to sell at these figures.

There continues to be a heavy consumption of canned goods by the lumber jacks and large quantities of pork and beans went into the camps last winter. These goods are packed in what are known as 2's and 3's tins, and are

found to be a very economical food. Although the price of white beans has advanced more than 25 per cent., the canned article is still sold at about the same price as last season, namely, \$1 per dozen for 3's tins.

Another line that is becoming more popular every year in lumber camps is jams, which are usually packed in pails containing from 7 to 30 pounds each, the prevailing price being about 7 cents per pound, which is somewhat higher than last year owing to the advance in the price of sugar and to the scarcity of small fruits the past season.

The lumber jacks have a special fondness for pies, in consequence of which there is a large demand for canned apples, peaches, etc. These goods are packed in water in hermetically sealed cans and are preferable to the dried article, being scarcely distinguishable from the fruit in its natural state. Gallon apples are selling this spring at about 1.90 per dozen, against \$2.20 a year ago. Pie peaches are quoted at about \$1 per dozen tins, against \$1.25 in the spring of 1904.

Dried peaches and apricots are about two cents per pound higher than one year ago, currants are unchanged, while prunes and raisins are lower. One year ago the price of the various grades of raisins ranged from 6¼ to 10 cents per pound, as compared with 5½ to 8 cents at the present time.

Many lines of groceries are now somewhat higher than usual and the trade are expecting an easier market this summer and fall.

CLOTHING.

Clothing supplies have ruled higher during the past winter and are still very firm. Owing to the prevailing high price of cross breeds and coarse wools, the price of many lines of woolen goods used by lumbermen have been advanced. This applies particularly to knitted goods, such as top shirts, shirts and drawers, oversocks, etc. In ready-made clothing competition between manufacturers has been quite keen, and there has been little if any advance in the price to the consumer.

Camp blankets are about the same price as last year, but we understand that there has been quite an improvement in the lines made by the Canadian mills and that they are taking the place of the shoddy articles so largely imported in the past. Cotton goods are now about as low as they ever were, consequently duck jumpers, cow-boy pants and overalls are lower than they were last year. A slight advance in the price of cotton goods would not be unexpected.

LOGGING APPLIANCES.

Owing to the conservative cut of timber throughout almost the entire Dominion, the past year was not particularly favorable for the logging tool business, although there was a fair demand. Axes were somewhat quiet on account of large stocks carried over from the previous season. Peavies and cant hooks did not suffer from this condition and were in good demand.

Prices of logging appliances show an upward tendency. Axes have been advanced 50 cents per dozen on full polished and double bitted

brands. All classes of steel goods, such as sleigh shoeing and general blacksmith's supplies, have also been marked up. Other lines, such as saws, hammers, wedges, mauls, etc., have remained stationary, but these will almost surely advance in price following the rapid rise in steel. The lines just mentioned have been unwarrantably low for the past eighteen months on account of severe American competition. The prices of peavies, cant hooks, and axe handles for the coming season have not been arranged, but it is altogether likely that these lines also will be advanced in a slight degree. The ruling prices of camp stoves and ranges are identical with those of one year ago, and as far as local conditions in Canada are concerned, there seems no good reason why there should be any change during the present year.

On account of the brisk demand for lumber, the outlook for manufacturer's of logging tools is bright. If the general prosperity of the country should continue unimpaired, the production of logs in the winter of 1905-6 will doubtless be larger than during the past winter, with a consequent increase in the consumption of lumbering appliances.

HORSES AND THEIR SUPPLIES.

The value of horse-flesh has not depreciated during the past year. The great increase in general trade and the continued prosperity of the country has caused the prices of good draught horses to advance, and while it has encouraged breeders to go on raising horses and improving their quality, there seems to be little likelihood of prices being lower in Canada. At the present time the average price of working horses is probably higher in Canada than in any other country, and when it is considered that we have practically no export trade, this speaks well for the prosperous con-

dition of things. General purpose horses from 1,300 to 1,600 pounds are worth about \$160. Buyers of this class are easily found at figures which two or three years ago would have been considered phenomenal. From present indications, lumbermen should figure on having to pay about ten per cent. advance this season on horses suitable for their work.

The cost of feeding a horse is about the same as one year ago. While hay is lower in

price, this is offset by the higher cost of oats. No. 1 Timothy hay, which one year ago sold in the Toronto market at \$10 to \$11, is now obtainable at \$8, while oats which could be bought in the spring of 1904 at 33 cents are now held at 40 cents. The home supply of

oats is not large, but future prices will depend largely on the outcome of the crops.

COST OF LOGGING OPERATIONS IN THE MARITIME PROVINCES.

(By Our St. John Correspondent.)

In making a comparison of the cost of logging operations in the Maritime Provinces of the season just ended and that of 1903-4, it is found that the changes in prices in all the most important lines have been in favor of the operator.

The most decided change has been in that most important factor, the wages of the woodsmen. In the winter of 1903-4, chop-

pers in the camps on the St. John river and its tributaries were paid from \$30 to \$32 per month and teamsters from \$22 to \$25. During the winter just past choppers were plentiful at from \$25 to \$27 and teamsters at a slightly lower figure.

The explanation of this substantial difference is simply that men of the stamp required were less in demand on account of the curtailment in the volume of contracts. What

the prospects are for next winter can be merely guessed at at this early date, but it is generally felt by those interested that when the time comes to begin operations again there will be little change. At any rate it is taken for granted that no such figures as those

paid in the fall of 1903 will be paid this year.

Horses were more plentiful last fall than was the case a year earlier and consequently somewhat cheaper. Horses such as sold for \$200 at the earlier date could have been bought at any time during the fall of 1904 or the ensuing winter for \$175, but prices are a little higher this spring.

Camp provisions also showed some important changes in price, but on the whole it might be said that in this line the reductions were offset by the advances. The following are the figures :

	Winter of 1903.	Winter of 1904.
Pork, per bbl.....	\$15.00 to \$18.00	\$14.00 to \$16.00
Corned Beef, per bbl.	14.00	12.00
"Star" Flour, per bbl.	5.25	6.10
Beans, per bush.....	1.90	1.80
Molasses, per gal....	.33	.35
Sugar, per cwt.....	3.75	5.50
Feed, per ton.....	24.00	22.50
Cornmeal, per bbl....	2.85	2.80
Oats, per bush.....	.44	.50

The prices paid for logging tools last fall were practically the same as those paid during the two previous seasons, and are as follows :—

Axes, single bitt.....	\$ 5.50 per doz.
Axes, double bitt.....	10.00 " "
Axes, hand-made, single bitt.....	6.00 " "
Axes, hand-made, double bitt.....	11.00 " "
Peavies, No. 1, handled.....	13.00 " "
Peavy handles, 5 feet long.....	2.60 " "

AREAS COVERED BY SHINGLES.

EXPOSURE.	Sq. ft. covered by 1 M shingles.		Number of shingles per 100 sq. ft.	
	4 inches wide.	6 inches wide.	4 inches wide.	6 inches wide.
4	111	167	900	600
5	139	208	720	480
6	167	250	600	400
7	194	291	514	343
8	222	333	450	300

On April 13 work was commenced on the construction of the Small & Bucklin saw mill at New Westminster, B.C. The plant will include a saw mill and planing mill and probably a shingle mill.



CANADIAN LUMBER CAMPS—EATING HOUSE, COOKERY AND COOKS.



CANADIAN LUMBER CAMPS—MEN'S SLEEPING CAMPS.

OBSERVATIONS AND EXPERIENCES OF A TIMBER EXPLORER

By J. B. BENSON.

The first thing to be considered in camp life is the outfit. Considerable judgment and experience are required to make up a proper outfit. More often campers err in having too much than too little. The lightest weight possible, consistent with what is absolutely necessary, is the great desideratum in an outfit. Overcoats, too much underclothing, heavy sleeping bags, etc., should be avoided if a party want to travel expeditiously and easily.

For summer work the following kit is all that is necessary on a timber exploration for a party of three persons. A light cotton drill tent, wedge shape, 7x7 and 7½ or 8 feet high, built with sleeves at each gable for the ridge pole to project through, so that the supporting crutches will be placed outside. This form of tent is preferable to others owing to the ease and quickness with which it can be pitched, while its sharp pitch sheds rain remarkably well. Light cotton drill is lighter than heavy canvas and should be chosen for summer trips. Three axes, two small and one larger, gives each man a tool to use when required to expedite pitching the camp, in cutting out portages, reblazing lines, etc. The cookery should consist of one frying pan, one tea or coffee pail, two larger pails (all of heavy tin) for cooking pork, beans and food generally, 1 folding reflector or baker, 3 knives and forks, 3 tin plates, 3 tin cups, 2 medium sized tin basins, and one large tin basin, also you should have four pairs of good grey blankets, 3 knap-sacks or canvas packing cloths. While some white men would prefer the knap-sacks with shoulder straps, others (notably Indians and Hudson Bay men) always use the tump line and packing cloth or blanket. I prefer a pack done up in a canvas packing cloth with tump line, after the Indian fashion. This form makes up the most complete form of pack obtainable, and gives one the camp clothes to use on the bed, or as extra shelter for grub or anything requiring to be sheltered during rain. One good Peterboro canoe 16 ft. by 31 or 32 in. beam and 12 in. deep, with 3 paddles, will carry three men and their complete outfit. Each man should have one change of flannel underclothes, one pair of good heavy shoe-packs or larrigans and 3 or 4 pairs of good woollen socks, an old hat, but no change of coat or pants. This dunnage can be stowed in a seamless cotton bag, which, with his coat, can be used as a pillow. Anything more than the above mentioned clothing would be unnecessary, and simply increase the weight of packs. Each man requires a jack knife and pocket compass, tobacco and pipe of course included, also a match-box. The chief usually supplies an awl, some wax-ends or hemp, thread and needles, buttons and two or three whet stones and a file. This outfit with provisions included should carry a gang of three men anywhere throughout this north country, with a great degree of comfort during the canoeing season.

Provisions are something which vary in quality and quantity very much with different men, or when in different localities. When near some source of supply where you can replenish, little need be carried at a time, and more luxuries can be indulged in. Some men, even when on comparatively long time trips, will carry a lot of canned goods, along with a heavy general outfit. This means very heavy work on portages, with often the addition of an extra canoe, and entails loss of time. For a trip of say one month, I usually provide 90 lbs. flour and 90 lbs. bacon, with about ½ bushel beans, 5 lbs. tea, 5 lbs. coffee, 10 lbs. sugar, baking powder, pepper and salt, soap, towels, pearlline and 5 lbs. rolled oats; your cook can carry a gun and some fishing tackle if he knows how to use them. Variety is thus added to the bill of fare and considerable sport also enjoyed. Such an outfit provisioned as I have described would mean a weight for the canoe of about 900 pounds, including the three men. Of course, in the stock yards of the Government Game Preserves fresh

meat is often obtained, particularly when in season, and when in good condition it is sometimes taken a little out of season.

For a winter outfit the canoe would be exchanged for two or three good toboggans (the Duchess are the best), also a wall tent about 10x10 with 2½ ft. walls, a camp stove of 15 to 17 lbs. weight, a good pair of snow shoes for each man, and 5 pairs of blankets. The camp stove is a very important article, and various opinions are held as to the best description for the purpose. There are folding stoves of many different makes, with telescope pipes, etc. Some have ovens and others are without them, each kind having its admirers. For my part I use a solid made stove, with straight 4 in. pipes with one elbow so that my pipes lead out through the tent front, and an oven which is hung on the side of the stove when in use, with the open side next the stove. The pipes pack up inside the stove. This I find is so air-tight that it holds fire far longer than any folding stove, giving heat at night without having to be replenished so often, never smokes, and can be set up more quickly. The pipes need cleaning less often, and its weight is less than that of a folding stove. The advantage gained in bulk when a stove is folded counts for very little. The solid made stove can be set up and a fire built in it



738 BUILDING DAMS FOR LOGGING PURPOSES.

while a man is taking the kinks out of a folder to get it hooked together, and it is generally a cold-finger job at best. Carry your pipe with an elbow through the end of the tent and no sparks will ever put ventilators through the roof, and a spark arrester or screen is unnecessary. The winter tent in front of an open fire is now nearly a thing of the past with bushrangers. During the coldest and most stormy night that may come you are comfortable and enjoy your pipe sitting in a tent with a stove. One undresses down to shirt sleeves, pants and socks, and by the light of a wax candle can pass the time until bed time with cards, smoking and story telling. At such a time the open tent and outside fire is not in it. Cutting the wood for an open fire in winter is a work of very great labor, as compared with the few sticks required for a stove. A pound or two of good wax candles should always be taken on a winter trip.

LOCATING A CAMP.

Wood, water and feathers (balsam boughs) are the main essentials required for a good camp. Look overhead and see if any standing timber or limbs are in danger of falling on your tent, and avoid such a location. If in winter, select a nice sheltered spot where the wind won't get a sweep at you. If the snow is deep, first have all hands on their snow shoes tramp a spot large enough for tent and door yard, until the snow will almost carry without your snow shoes on, then spread some fair sized balsam boughs over the snow, and proceed to pitch the tent. It is usually the best plan to peg down the four corners first, then run the ridge pole through and raise it up, securing it to the proper height with the crutches on the outside of

the tent, then peg down the sides between the corners, and stretch out and fasten the side guys to the stakes. Use no legs to the stove but drive four green stakes down through the snow until they reach ground and are firm; on these stakes place the stove. Don't be alarmed about these wooden stove legs catching on fire, they seldom or ever do. A 6 or 7 inch log should then be placed across the tent about 18 inches from the stove, inside of this pole you proceed to make a good comfortable bed of balsam, hemlock or spruce boughs, placed shingle fashion with the tips toward the head, in such a manner as all bush rangers know how to do when a nice comfortable and healthy bed is required. A 10 ft. tent with a toboggan placed along one side makes a place for all your provisions and cookery. Then with two armfuls of wood behind the stove you can close up shop, light your candle and go in for comfort in the bush.

CHOOSING YOUR MEN.

It is not always easy to procure men suitable for your work. You may find a man from some town who will be recommended as a first class canoe man. He may be all that is required to handle a canoe in still water or on lakes, and capable of guiding tourists and fishing parties around waters which he knows; but in swift waters and rapids he is out of his element. Besides he very often knows little or nothing of ordinary wood craft, and therefore becomes a burden to you on many occasions. If possible, look for your men in the backwoods, or choose those who have been brought up or spent a great deal of their time there. They are accustomed to handling an axe, canoe, or pack; and altogether I have always found that class the best to choose from, they are contented with a lighter outfit, and seldom lose their reckoning when in the bush. An Indian is always good on his own hunting ground, and is very capable of packing and handling and keeping his bark canoe in good shape. Outside of his own country I prefer the white man. A green hand should never be taken unless you are willing to put up with great inconvenience and appoint yourself his tutor in matters of woodcraft. I once took a good canoe man along who came to me in the bush after I had been located. He brought a personal kit with him composed of enough ammunition for a deer hunting party—a rifle, half a dozen mink traps, and enough tools, etc., to build a Peterboro canoe. His kit made a heavy pack by itself and was a constant source of annoyance to me until I accidentally drowned it in the river where it could not be recovered. After that fortunate accident our packing became easier, and my worry ceased. Still his woodcraft ended when he got out of his canoe. I had another man highly recommended by his townspeople who was continually getting lost. In one of his wanderings we spent two days hunting him up, and then had hard work to convince him that it was he who was lost and not the wigwam. I put another fellow on shore one day to follow the canoe (which was heavily laden) down the stream. He in some way turned about and walked up-stream instead of down, with the result that we had to waste a few cartridges from our gun before he was recovered. He then contended that the creek had changed its course and was running up-stream. Few bushrangers ever get lost. They may get too far away from camp sometimes to reach home that day, but they always know from the waters and the topography of the country where to find their camp, and are sure to turn up in time for a hearty meal the next morning.

CANOES.

There is a great diversity of opinion among bushrangers as to the best description of canoes for a trip, some prefer the Bark to any other. That the Bark is lighter than the Peterboro of the same carrying capacity, and therefore easier to portage, is true. It may also be somewhat better in rough water, owing to its greater depth, but here I think its better qualities end. The Peterboro will stand more roughness, is always free from leaks, can be mended quite as easily and quickly as the Bark (with some pitch and canvas), and is faster. I always use, when possible, a

Peterboro, and I find that it generally has the preference among bushrangers in Ontario. In New Brunswick, Maine, and down the Gaspé way, a long narrow dugout called a Perouge, is often used, also a large Gaspé canoe made of balsam or whitewood about 20 to 24 ft. long, built lap streak with boards. These canoes are driven by two men with iron shod poles about 11 feet in length, one in each end, who pole up stream. They manage these canoes with a dexterity taught by long experience, and in a manner that the best canoe men in this part of Canada would be novices at. We can teach them to paddle, but we know nothing about poling. In rough and swift water they force these canoes through places where we



NEW BRUNSWICK SPRUCE LOGGING CAMP.

would simply go ashore and carry around. Heavy and large Barks are also used in that country, mostly by the Indians, who are employed as guides by the salmon fishermen. Very fine canvas covered canoes are built in Maine and in some factories along the American side of the St. Lawrence. They are similar in size and general design to our Peterboros, and I have found them good in every respect, except that they are a trifle heavy. Peterboro is I think the home of the original Peterboro canoe, although they are now built all over this country, and this style of canoe is usually designated as a Peterboro canoe.

A canoe builder in another town once told me of an experience he had with a buyer who wanted a Peterboro canoe. During his bargaining for a canoe, which he was told was a Peterboro, he discovered that this builder had made it himself, and therefore promptly rejected it, saying he wanted a regular Peterboro, made there, and no other would suit. The builder told him to call next day and he would have some in. He called and bought a canoe of the builder's own make. He departed, satisfied that he had the real article, and to this day has never found his mistake.

Canoes vary in weight from 40 to 80 lbs. and sometimes are made as light as 20 lbs. The general purpose basswood painted canoe of about 16 ft. weighs about 70 lbs. Any good man can carry one of these over a portage without much inconvenience; basswood and cedar are the woods mostly employed. Cedar is nearly always lighter than basswood but basswood will stand more hard usage, and has also a habit of breaking in better form for repairs than cedar. The care of a canoe is something very often shamefully neglected. Never leave your canoe bottom upwards in the sun, turn it bottom up at night and during rain-storms, keep it when not in use in a shady place, and never fill it with water to tighten it up. Paint should make any properly built canoe water-tight. Never scrape your canoe on rocks or stones when hauling out, and always take it out of the water when not using it. Whenever possible have your canoe floating when you enter or land from it, never rub the gunwale of your canoe when paddling; it is bad form, frightens the game, and injures the appearance of the canoe and paddle. Paint up every spring. By close attention to the foregoing hints, an ordinary Peterboro will last for a good many years. There is now in this town a Peterboro which came from the shop of R. English 22 years ago; it is still on deck, and goes duck shooting every season.

BUSH RANGING.

"Bush ranging," as we generally call it Ontario, is

designated "land looking" in Michigan, and "cruising" in New Brunswick, Maine and Nova Scotia. It is also called "exploring" here. The men who follow or engage in this business are usually those who have had a considerable experience in logging and general work in the lumbering districts; they thus bring a practical experience along with a fair general intelligence which enables them to arrive at a close approximation of quantities and quality of the timber growing on a given area. The plans adopted vary according to locality and general conditions of the timber to be estimated. Sections of land are often paced off into half quarter and quarter-quarter sections. A good pacer will come out very close to the post, and nearly

all bush rangers are very capable at this work. Areas of land are often computed from water boundaries surrounding a block of timber. Trees are sometimes counted. Different ways are adopted to arrive at quantities by different men; the figures obtained by the different rangers all bear a close affinity to each other, and sometimes are amazingly alike. Upon the reports of these men deals of great value are made. Rangers of experience enjoy the confidence of the lumbermen of the country to such an extent as to induce them to invest millions on their judgment as to timber limits. They have to stand a large amount of roughing and exposure, but usually become wedded to the life as closely as a sailor to the sea.

Bushrangers often meet with strange, and some-



BOATING CAMP SUPPLIES UP THE RESTIGOUCHE RIVER IN NEW BRUNSWICK.

times startling adventures. I have known men to have been treed by wolves, but the writer was once treed by a bull moose. Mr. Moose came upon me so suddenly that I barely had time to shin up a birch tree, out of reach. He fairly reared up against the tree in his endeavor to reach me, struck at the tree with his fore feet and pawed up the ground about the tree until I almost began to think he was bent on uprooting it. His hair stood on end and his eyes blazed fiercely. The rascal kept me there for about two hours, when he heard a cow call, and then after giving me a last look of disgust started off on a trot. I had nothing with me but my little axe. Had it been a rifle we might have had a steak for supper. As it was, I was

glad to get down from my cramped position and make lively tracks for camp, which I failed to reach until after dark. Moose, as a rule, will get out of the way, but if come upon suddenly in the fall of the year, the bulls will sometimes show fight. I would not advise a man, in the moose country, to use a moose call, unless he is loaded and prepared to shoot. I knew of two men who were up the French River hunting ducks, and while they were up on shore having a smoke, they began to practice on a patent moose call which one of them had, the result of their practice being to bring a big bull charging down upon them so suddenly that they had barely time to reach their canoe and push from shore.

Wolves as a rule are arrant cowards, and a shot will generally cause them to drop their tails between their legs and run. In packs at night they gain courage and are then unwelcome visitors. As often as I have come across wolves I never had but one thrilling experience with them, and it was of such a desperate nature that for weeks afterwards I never thought of it without a shudder. Away back in the fifties wolves were plentiful in nearly every part of the Canadian lumber woods. At that time I was engaged in looking after two logging camps, and arrived at one of these camps at about noon. Leaving my horse and cutter at this camp I started over to the other on foot, intending to return in the late afternoon, a distance of three miles. I made the camp in good time but missed seeing the foreman, who did not come in until nightfall. As wolves were known to be somewhat plentiful, and my pistol was behind at the hack camp, the foreman induced me to stop overnight. In the morning, just as day began to break, I started to return. Something impelled me to take a stake from a hay sleigh as I passed the stables. Being lightly clad and wearing moccasins I was in good shape for travelling. I made good time down the well beaten road until I struck the lake upon which the logs from our first camp were being dumped. It was getting light then, and although I heard wolves in the bush thought nothing of it until, upon looking around, I saw three or four dark forms moving out from the shore on to the lake in my trail. Then I realized that they were after me. In those days I was considerable of a sprinter, and in the height of my vigor as a young man. Seeing more dusky forms closing fast in on my track, I then began the race of my life, and for life. As it was about

time for the first team to reach the dump, I made up my mind that if I could make there when it arrived, I should be safe. As I ran, I heard the feet of the pack thumping nearer and nearer, and in desperation I dropped off my mitts to get a firmer grip on the sleigh stake. Soon I heard a succession of growls and snarls, and on looking around saw that they had all stopped pell mell and were having a scrap over the mitts. This gave me a little of a start and also an idea which I soon adopted by dropping my good fur cap. This ruse again stopped the pack for a short time and enabled me to reach the log dump, but with no team in sight. Here with my mind made up that I was to be torn to pieces by these blood-thirsty animals, I

placed my back to the end of a shore skidway of logs and began playing my sleigh stake back and forth with such energy and desperation as actually to keep the rascals at bay. Then I thought of my wife and two little children at home in their comfortable beds, unconscious of my terrible doom. I prayed for my pistol, that I carelessly had left behind; for the leading team to come; for anything to escape the horrible doom that I felt must soon overtake me. The brutes were getting fiercer and fiercer, their hair on end, eyes snapping, and frothing like demons at the mouth. I never shall forget that fight. I hit one on the foot and made him howl like a whipped cur, and one fellow that appeared to be the leader I gave a bat on his jaw which made it hang down (broken, I think), but all the time I was wearing out my strength very fast, and just as I began to waver in my defence I heard the joyful sound of bells. The wolves heard it at the same time, and backed off a bit. Then I heard the word "who" as the leading team came down the grade to the dump, and knew I was saved. Then I made a rush at my foes and fell headlong on the ice as the pack slunk off across the lake, and the teamster and dumper picked me up, utterly unable to speak a word. It was a long time before I could efface the vicious appearance of those six wolves from my thoughts.

I was camped on a bend of the Upsquitch river in New Brunswick at one time, and as our party of three cruisers were engaged eating our dinners beside the tent fire, a big bull moose suddenly thrashed down on us before he saw the tent. It rather startled him, and he was wheeling to beat a retreat when a gust of wind threw open the front of the tent. Mr. Moose must have thought this a challenge to fight, for he instantly charged the tent, planting both fore feet on it, and bearing everything down. Then he walked over it, and finding no more hostile demonstrations coming, he walked off about 20 rods and stopped to look back at his late foe. That was his last stop, as by this time our whole camp (which had rushed for safety to the nearest trees) had recovered their fright. The rifle soon came out from under the fallen tent and for a long time thereafter we had fresh moose meat. It took us half a day, and used up nearly all the thread in camp, to repair the tent.

Foreigners are often too prone to think that the backwoods of Canada is so full of wild animals that bears, wolves, lynx, moose, cariboo, deer, etc., can be met with at any time. The fact is they are most difficult to find, and one need not be loaded for bear to travel safely all over our Northern wilds.

I had a hard experience on the River Gounamity in New Brunswick some few years ago, and left my outfit there in evidence. Along with a Frenchman and an outfit of two pairs of blankets, toboggan, and some grub sufficient for four days, we had crossed on snow shoes about twenty-five miles over the country from the lumber camp where our horse and rig had been left. The snow shoeing was fairly good and we had made the river in about time to camp for night and decided to cross to what appeared a nice camping ground on the opposite side. There was an ice bridge directly opposite where we were, but both above and below the river was open and very rapid. We had our snow shoes off and I crossed over safely with the shoes and my little axe, and told my man to come along with the toboggan. He started and got just in the middle of the stream when the ice gave away and he and toboggan went in, he let his Toboggan go to save himself, when the ice gave away in the bridge below him and away went toboggan and our grub and blankets. After considerable trouble I got him ashore wet to his neck; then we found ourselves in a bad fix. We could not find our toboggan, had no grub except a small bag of tea which in the packing up after noon meal had been neglected, and which I had put in my coat pocket. Luckily my matches were dry, so we made a big fire and danced around it all night to dry our clothes. We tried smoking instead of eating for our suppers but found it hardly up to the mark. To make matters worse, it began to rain during the night, and by the morning the snow-shoe travelling was horrid. We started in the early dawn to get back to the lumber camp with the snow sinking a foot or so at every step, after having crossed the river on a tree which we fell lower down. Then came the tug of war,

my man was continually lamenting our sad fate, saying we would meet the fate of a surveyor who the previous season had failed to get out of the bush, although he was a stronger man than I. He had to be encouraged and coaxed along or he would have given up in discouragement. We took turns in breaking the track and at noon had not made more than six or eight miles. We made a cosseau of birch bark and by heating small stones tried to make tea by putting them in the water, but it was a sorry affair. We made dinner on it and after a smoke started again on our fearful tramp. The rain continued all day and we were wet to the skin. At night we reached the Restigouche River, only to find it all open and the ice rushing down in furious form. We camped on its banks by the side of a good fire, and no rain that night. By this time our pipes had lost their charm, and smoking became impossible. We slept well and in the morning our hopes revived, as it had frozen a bit, and the travelling would be good until noon, if we could only manage to cross the river. After a couple of hours of the hardest work I ever engaged in, we managed to fasten three cedar logs together and cross the stream, landing about a quarter of a mile lower down. We felt alright then, although hardly able to drag one foot after the other. By noon we reached the camp, having eaten nothing since noon two days before. We made a great hole in the cook's provisions, luckily without injury to ourselves, and both slept until well on in the night. That was a longer fast than I was used to, and don't care to ever repeat, and the Gounamity still has possession of my camp kit.

A foreigner was once being taken up the mountain near Montreal by a Scotchman acquainted with the country. In the course of their ramble they came across a snow-shoe track. The foreigner expressed great surprise at such a monstrous track and inquired what beast had made it. The Scotchman, in dry humour, told him it was the track of the animal called the Great Canadian "Snau Sho". In terror the stranger insisted upon returning at once, as he had left his heavy rifle at the hotel.

The Indians, it is said, often leave an old person in the woods to die. Such a case I once came across up at the headwaters of the Gatineau river. One very cold February, I found myself up the river on the Fox River Branch, and came across two snow-shoe tracks, also a dog and apparently a small toboggan track. We examined it, as is always customary, and came to the decision that some Indians must be camped in the neighborhood, but we wondered why we had never before come upon their tracks. Upon returning to our camp near evening we found these tracks again, and this time following in on our morning trail. Shortly after, when about half a mile from camp, we came upon the party of the tracks, an old woman said to be a century old, a small boy and a yellow dog. They were getting ready to camp for the night. They had a hole dug in the snow over 4 ft. deep and about 4 ft. in diameter, with a cotton sheet spread over the top, some spruce brush on the bottom for a bed, and a little wood ready for a fire. The old woman was dressed in a grey cloth coat, red sash and tuque, with rabbit skin leggings, and with a cane in one hand and a small dry spruce under the other arm, was lugging up the wood which the boy had cut for their night's fire. The boy had a suit of rabbit skin. Their total outfit consisted of a cotton cloth about six feet square, a small frying pan without a handle and a small tin pail and axe. This outfit the boy carried on a sort of a toboggan made out of a beaver's skin stretched on hoops. Their provisions consisted of about half a lake trout, partly smoked.

One of my men spoke Indian, and from the old woman learned that her people had gone off in the fall in their canoes and left her to do as best she could during a cold hard winter. They had been able to snare partridges and rabbits during the fore part of winter, but latterly this source of supply had failed and they were forced to make their way out to the Indians living on the Gatineau, or starve. The old woman was the oldest looking person I ever saw, almost the color of a mummy, and although bent nearly double, must at one time have been a remarkably large woman. Their rate of travel per day had been only about three miles, as we afterwards found, and their camps formed simply by a hole in the snow. How they ever existed

through that cold weather was a mystery—it was an experience that would have tried the most robust man. We took them down to our camp, in an old lumber camp, and made their hearts glad with pork, tea and tobacco, and a good combose fire to camp beside. The next morning we loaded up the boy's toboggan with grub and started them off happy, and with stomachs filled to overflowing. I am glad to say that they reached their destination, and had revenge on their people by not dying in the bush that winter.

MODERN SAW MILL EQUIPMENT.

Mr. I. N. Kendall, the well-known designer and builder of saw mills and saw mill machinery, has established an office at 203 Bridge street, Ottawa, and is having the machines of his own invention and design built under his personal supervision, so that when a machine is turned out he will be in a position to guarantee it to be correct in every particular. He intends to sell his inventions direct to the trade. His special machines at present consist of variable gang circular, improved resaw, steam nigger, hog, pulp chipper, and improved valve for niggers and log loaders.

In his work as a practical millright during the last twenty years, Mr. Kendall has had occasion to install and operate a great many different makes of "Hogs." With all of them the great objection he found was the

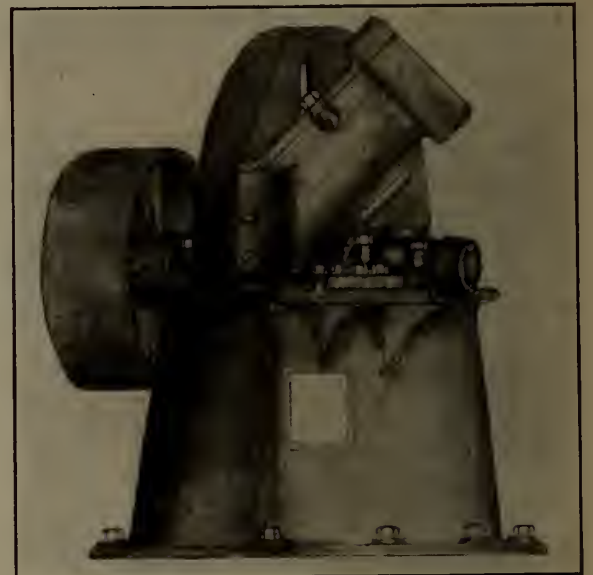

"HOG" MANUFACTURED BY I. N. KENDALL, OTTAWA.

amount of power required to operate them. To overcome this objection, he designed the machine represented by the accompanying illustration. The spout leading to the knives is not at right angles to the disc wheel, but is swung in at the top towards the centre of the wheel until it makes an angle of 65 degrees with the disc instead of 90 degrees. In the throat of this spout next the wheel a square recess is made in which are fitted two tool steel blocks, tempered as hard as fire and water can make them. In turning round, the knives in the disc wheel pass these steel blocks just as closely as possible without actually touching. This gives a shearing cut and is the principal reason these machines are so successful in cutting thin stuff, such as lath and planing mill refuse.

A machine with a wheel 60" diameter, or 20" larger than the one in the illustration, has been in operation in a saw mill in Newfoundland for the last three years, cutting slabs and edgings into fuel chips. This machine has been driven for the three years by an 8" 3-ply rubber belt, the same belt having been in constant use for the three years, and apparently it is in fit condition for several years more. This is satisfactory proof that the machine does not require much power to operate it.

Mr. Kendall is also prepared to furnish plans and estimates for the building of new mills or the rearranging of old ones and will also design and furnish any special saw or pulp mill machinery that may be required. His announcement will be found in this issue.

W. C. Feindel, of Middleton, N. S., has branched out into the manufacture of lumbermen's peavies and is said to be producing a superior article.

HARDWALL PLASTER.

It is only about three years since the introduction of hardwall plaster took place in this country, but though so recent, it now bids fair to completely oust the old line plaster from its position in the building trade.

Americans have for many years been familiar with the new material and lime is seldom used now in Uncle Sam's dominions, and it is to them that we are indebted for our first knowledge of it here.

Gypsum, from which hardwall plaster is made, occurs only in isolated locations and only in a few of the states of the union has it been found. In Canada the same holds true, and the known deposits of gypsum can be counted on the fingers of one hand.

The deposits owned by the Manitoba Gypsum Company are probably the most extensive in the Dominion, and the company claim the quality to be superior to anything south of the line. These extensive deposits were known many years ago as mica, from the resemblance to that article of a crystalized form of some of the gypsum, but owing to their distant situation between Lakes Winnipeg and Manitoba, north of Lake St. Martin, they lay for years untouched. It was only when the use of hardwall plaster began to be appreciated that some enterprising spirits thought of using them, and about three years ago they came into the possession of the Manitoba Union Mining Company. This company built a plaster mill at the head of Portage Bay, Lake Manitoba, and put a steamer on the lake to transport the product to Westbourne Landing.

Although handicapped in many ways, this company was able to prove the value of its gypsum as a first-class hardwall plaster producer and put an article on the market that was a close competitor to American plaster.

In the able hands of prominent contractors, Manitoba hardwall plaster has been used on many of our best buildings, among which it is sufficient to mention the Union Bank, Merchants Bank, and the new C.P.R. station, Winnipeg.

Last fall the Manitoba Gypsum Company bought out the Manitoba Union Mining Company, and have made such extensive changes in the plant that the output for the coming year will far exceed that of the old company, both in quantity and quality. The capacity of the mill has been increased from 30 tons daily to 180 tons. The steamer used by the old company has been completely overhauled and her capacity doubled, and a new twin screw steamer up-to-date in every way is in course of construction. A tramway from the mill to the quarries is being built and everything that can be done is being done to make the business a success.

Mr. D. E. Roberts, of the Plymouth Gypsum Company, of Fort Dodge, is in charge of the manufacture, and as he is one of the most experienced plaster men, the trade are assured that the goods put on the market by the Manitoba Gypsum Company will be first-class.

Wood-fibre plaster, the latest development in hardwall plaster, will also be a prominent feature of the company's production.

Wood-fibre plaster, from the fact that it can

be used without sand, will probably recommend itself to those living in parts of the country where sand is scarce, but apart from this, it will be more and more largely used on account of the very fine, hard and tough wall it is capable of making, and also from the fact that it makes a wall that is a non-conductor of sound.

All Canadians are interested in seeing the products of their own country developed, and in the enterprise of the Manitoba Gypsum Company, there is the assurance that a Canadian industry is being developed in a way that its product ought to meet a ready demand from the building trades, and all the company asks is a fair field and no favor.

The company say they propose to offer Canadian goods to buyers at a price that non-Canadian goods cannot touch.

PERSONAL.

Mr. Frank B. Gould has been appointed superintendent of Tanner Bros' saw mill at Waubaushene, Ont.

Mr. William Irwin, lumberman, of Peterboro, Ont., contemplates moving to British Columbia, where he has extensive interests.

Mr. J. A. Gillies, of the Gillies Bros. Company, Braeside, Ont., has recently been in Mexico looking over several tracts of hardwood timber.

Mr. J. W. Coburn, of the Ladysmith Lumber Company, Ladysmith, B.C., returned to the West recently after a short visit to his home at Harvey Station, N.B.

Mr. Byron A. Bent, construction foreman for Rhodes, Curry & Company, Amherst, N. S., was married on April 20th to Miss Nellie Gullivan, a popular young lady of Middleton, N. S.

Mr. J. R. Booth, the lumber king of Ottawa, celebrated his 79th birthday on April 5th last. It is a source of gratification to his many friends to find him hale and hearty and able to personally supervise his vast business enterprises.

Our congratulations are extended to Mr. H. J. Scott, president of the Scott Lumber Company, Fredericton, N.B., who on April 25th last was united in marriage to Miss Ethel Irene, eldest daughter of Mr. George W. Mersereau, of Doaktown, N.B.

Mr. Frank Oliver, M. P. for Edmonton, N.W.T., has been appointed Minister of the Interior, to succeed Hon. Clifford Sifton, who resigned over the educational clauses of the Autonomy bill. Mr. Oliver was born in Peel County, Ontario, in 1853, but went to the Northwest at an early period in his career.

Mr. T. F. Kenny has been appointed Mechanical Engineer of Allis-Chalmers-Bullock, Limited. He graduated from the Department of Mechanical Engineering at McGill University in 1896 and then spent two years with the British Columbia Iron Works. For the past six years he was Mechanical Engineer for the Jenckes Machine Company, Sherbrooke, Que.

Mr. A. E. Warrington, shipper for M. Brennen & Sons, Rainy Lake, Ont., was a caller at the CANADA LUMBERMAN office during the past month. Mr. Warrington states that the lumber business in Algonquin Park is flourishing, and that there is a good demand for both pine and hardwoods. Only one firm in the park, however, are permitted to cut the hardwood timber, their limit having been purchased before the park was set aside.

In common with a wide circle of business and social acquaintances, we extend our sympathy to Mr. R. H. H. Alexander, Secretary of the British Columbia Lumber and Shingle Manufacturers' Association, Vancouver, who has been confined to his home for about three months as the result of an affection of the eyes. We are much pleased to learn that during the past month his condition has improved, and we hope for a speedy recovery. As secretary of the Lumber and Shingle Association, Mr. Alexander is highly esteemed and his work much appreciated.

TRADE NOTES.

D. K. McLaren, manufacturer of oak-tanned leather belting, Montreal, has opened a branch at St. John, N. B., under the management of W. F. McLaren.

The Burton Saw Company, of Vancouver, B. C., have recently purchased a stock of Oldham bands and are fitting up machinery for manufacturing band saws for use in cutting lumber. This will add to their already rapidly growing business in circular saws, which they manufacture from 12" to 60" in diameter.

The extensive business of Woods, Limited, of Ottawa, has rendered their factory and warehouse accommodation inadequate, and work was commenced during the past month on another new building on Slater street. It will be 70x210 feet, seven stories and basement, of fireproof construction and containing the most modern equipment.

The Canadian Pacific Railway have placed with Allis-Chalmers-Bullock, Limited, Montreal, an order for four Lidgerwood 25-ton pull Rapid Unloaders. Among modern devices for reducing the cost of railway construction the Rapid Unloader takes a leading place. It is a compound geared winding engine of two sizes—25-ton pull and 60-ton pull—mounted on ordinary flat cars and supplied with steam from the locomotive. The engine of the smaller size just purchased by the C.P.R. has double 10x12" cylinders, is capable of exerting a direct pull on the cable of 25 tons and of drawing in the same at the rate of 125 ft. per minute. The drum is 41" diameter and is grooved for 1 1/4" cable. This new device is in strong contrast to the old method of drawing the plow by use of locomotives. It can be operated by any locomotive strong enough to pull the train. The Canadian Pacific Railway have already fifteen of these machines in operation—one of them working at Westmount unloads a train of twenty-five standard flat cars in nine to ten minutes.

A PAYING SIDE LINE FOR LUMBERMEN.

F. W. Bird & Son, East Walpole, Mass., manufacturers of the celebrated Paroid Roofing and Neponset Waterproof Papers, are erecting a factory in Hamilton to take care of their growing Canadian business. For nearly a century this concern has been making papers and felts at their factory in East Walpole, Mass., and they now have thousands of dealers all over the country and abroad handling their goods.

Paroid is known as the roofing of quality and it promises to have the same success in Canada as it has had in the States. A large percentage of the lumbermen in the States handle Paroid as a side line, and it will pay every lumberman to get their proposition immediately, for they are soliciting new dealers and someone is going to make a profitable side line in every section. Paroid can be used in places where shingles cannot and it does not conflict in any way with the lumberman's business. Address F. W. Bird & Son, Hamilton, Ont.

The Imperial Paper Mill Company are building a sulphite mill in connection with their plant at Sturgeon Falls, Ont. They expect to have it in operation during the coming fall.

An effort is about to be made on some of the streams to recover "dead-head" timber, which amounts to a considerable value. The "rear sackers" have always lost a certain percentage, which went to dead-heads, and an effort will be made to recover a large proportion of these sunken logs.

Mr. J. C. Graham, the popular and well-known manager of the Prairie Lumber Company, Winnipeg, has severed his connection with this company and will take an extended trip. The office staff and agents of the different yards of the company felt that they could not allow the opportunity to pass without in some tangible manner showing their appreciation and sincere regard for him and presented him with two valuable pieces of beautiful cut glass. This was more than the warm heart of Jack Graham (his familiar title) expected, and the surprise left him speechless, but like the well-known lumberman that he is, he rallied to the occasion, and in a few well-chosen words heartily thanked them for the selection of a present, of which both he and Mrs. Graham would be proud.

THE Canada Lumberman

AND WOOD-WORKER

(Monthly and Weekly Editions—One Dollar Per Year.)

PUBLISHED BY

The C. H. Mortimer Publishing Company
of Toronto, Limited,

CONFEDERATION LIFE BUILDING, TORONTO

BRANCH OFFICES:

38 ALLIANCE BUILDING, MONTREAL
720-721 UNION BANK BUILDING, WINNIPEG
22 GREAT ST. HELENS, LONDON, E. C.

The LUMBERMAN Weekly Edition is published every Wednesday,
and the Monthly Edition on the 1st day of every month.

TERMS OF SUBSCRIPTION:

One Copy, Weekly and Monthly, One year, in advance, \$1.00

One Copy, Weekly and Monthly, Six Months, in advance, 50

Foreign Subscription, \$2.00 a Year

ADVERTISING RATES ON APPLICATION.

THE CANADA LUMBERMAN AND WOOD-WORKER is published in the interest of and reaches regularly persons engaged in every part of Canada in the lumber, wood-working and allied industries. It aims at giving full and timely information on all subjects touching these interests, and invites free discussion by its readers.

Special care is taken to secure for publication in the WEEKLY LUMBERMAN the latest and most trustworthy market quotations throughout the world, so as to afford to the trade at home and abroad information on which it can rely in its operations.

Advertisers will receive careful attention and liberal treatment. For manufacturing and supply firms wishing to bring their goods to the attention of owners and operators of saw and planing mills, wood-working factories, pulp mills, etc., the CANADA LUMBERMAN AND WOOD-WORKER is undoubtedly the most direct and profitable advertising medium. Special attention is directed to "WANTED" and "FOR SALE" advertisements, which are inserted in a conspicuous position on front page of the Weekly Edition.

INSURANCE OF STANDING TIMBER.

A rather unusual case of interest to lumbermen has just been decided by the Trial Court at Ottawa, the question in dispute involving the insurance of standing timber. The plaintiffs were the Canadian Pacific Railway Company and the defendants the Ottawa Fire Insurance Company. In consideration of the payment of certain premiums, the Ottawa Fire Insurance Company agreed to insure the C.P.R. against loss or damage caused by locomotives to property located in the State of Maine, not including that of the assured, or upon land owned, leased or operated by the assured. On May 11th, 1905, fire was communicated from one of the plaintiffs' locomotives to certain standing timber in the State of Maine whereby it was damaged to the extent of \$10,000 and upwards. The owners made claims upon the C.P.R. to the amount of their loss and settlement was effected by the payment of \$9,698.94. The C.P.R. then sought to recover the amount, under their policy, from the Insurance Company, who denied all liability on the ground that they had no power under their charter to insure the property so destroyed or damaged or to indemnify plaintiffs in respect thereof.

The Act under which the Insurance Company was authorized to carry on business reads as follows: "Every company licensed and registered for the transaction of fire insurance may, within the limits prescribed by the license and registry, insure or reinsure dwelling houses, stores, shops and other buildings, household furniture, merchandise, machinery, live stock, farm products and other commodities against damage or loss by fire or lightning." The defendants contended that their rights as above specified did not extend to standing timber, while the plaintiffs held that, if such be the case, they were entitled to recover the sum of \$21,000 paid as premiums, with interest. It

was shown that the defendants never insured or assumed to insure standing timber on any other location, and the learned judge limited the meaning of the word "property" to the classes of property defined by the Act. He therefore ruled that the plaintiffs were not entitled to recover for the loss sustained nor for the premiums which had been paid. As affecting the latter, it was decided that the policy was a valid one and that the plaintiffs had been fully insured and indemnified against claims for loss or damage to such property as defendants had power to insure.

It was argued that the railway passes through a wooded country where the loss must chiefly be that of standing timber, but upon the trial it was shown that there was more than \$500,000 worth of property along the line that would fall within the class of property which defendants might insure under their statutory powers.

THE ONTARIO TIMBER POLICY.

It is expected that the Conservative party which recently attained power in Ontario will make an early announcement in respect to their timber policy, which, if we may venture a guess, will not be radically different from that of the late government. It is believed that the plan proposed by the former Commissioner of Crown Lands, Hon. E. J. Davis, for the lumbering of the forest reserves, will be practically adopted. This plan embodies the selling of the timber by the thousand feet as it actually matures, the trees to be cut to be designated by the employees of the government. Probably on land suitable for agricultural purposes the present system of selling the timber by the square mile will be continued, as it permits of the land being quickly cleared and opened up for settlement.

No great difficulties are likely to be encountered by the new government in the framing of acceptable regulations for the disposal of the timber. The problem demanding the most careful legislation will probably be found to be the defining of the rights of the lumberman and the settler. A deputation representing practically all the principal holders of timber licenses in the province recently waited upon the Premier, the Commissioner of Crown Lands and the Commissioner of Public Works in this connection. Among other things they asked that government inspectors should be appointed to report upon the adaptability for settlement of localities situated within districts under timber licenses, and unless at least a fixed percentage of a township was found suitable for cultivation, such lands should not be opened for settlement under the Free Grants and Homesteads Act, and, if already open, should be withdrawn; that twelve months' notice should be given when it was intended to open up land under timber licenses for settlement; that locations included in the timber licenses bought at the sale in 1903 should not be open for settlement until the time allowed for taking off the timber had expired; and that greater attention should be paid by the government to the prevention of fires and the exploration of the country.

What the members have asked for is in large measure supported by the Canadian Forestry Association and may therefore be considered to be in the public interest. It is essential that the settlement laws of the country should place no unnecessary obstacle in the path of the settler, but it is equally essential that settlers should be excluded from lands which are unfit for cultivation. The country will receive greater benefit by permitting the land to remain in timber than by allowing a settler to locate in the district, perhaps to remain but a short time but long enough to be responsible for a fire which may destroy much valuable timber.

The interview above referred to has brought forth an appeal in the Toronto World from a resident of the Parry Sound district signing himself "Settler." It is not difficult to read between the lines that this settler fears that the government may adopt such regulations as will render it more difficult for the timber speculator to exploit his plans under the guise of a bona fide settler. The Commission appointed by the Quebec Government to report on the question of the relations between the holders of timber licenses and the settlers found that there was no antagonism existing between them except in the case of settlers who take up public lands with the view of speculating on the timber, and we doubt if the situation in Ontario is very different.

UNJUST RULES FOR SHIPPING OF LUMBER.

As if to relatiatate upon the lumber trade for its agitation to compel the railroads to properly and completely equip their cars for the reception and transportation of lumber, the Grand Trunk Railway Company have recently taken action towards the enforcement of new rules of a rather absurd character. We understand that they are an exact copy of the rules adopted by the Car Builders' Association, and the most objectionable clauses are as follows:

No. 12. All stakes, clamping pieces, bearing pieces and braces must be sound, straight grained lumber (hardwood preferred) and free from knots that would materially impair their strength. (Hemlock must never be used.) Care must be taken to keep the stakes from spreading at the top while cars are being loaded, and in no case must the load exceed the width of the car. Unless otherwise specified, stakes must not be less than four (4) inches wide by (5) inches deep, or saplings five (5) inches diameter at the centre, tapered at the ends to accurately fit, extend through and completely fill the stake pockets, which should not be less than three and one-half (3½) inches wide by five (5) inches deep.

No. 13. Opposite stakes must always be fastened together. When the specified fastening is by means of boards, there must be two boards for every pair of stakes, each board not less than one (1) by six (6) inches in section, unless otherwise specified, and fastened at each end by not less than three ten-penny wire nails. (Hemlock must never be used.) When the specified fastening is by means of wire, the wire used, unless otherwise specified, must be equal to six strands of three wrappings of No. 8 telegraph wire (or wire of equal strength) and the wire must be secured to prevent it from slipping.

No. 32. For flat cars and gondola cars with sides less than thirty (30) inches high, not less than four stakes four (4) inches by five (5) inches deep must be placed on each side of car and the tops of opposite stakes must be held together by two one (1) by six (6) inch boards fastened at each end by means of three ten-penny wire nails, or by six strands equal to three

wrappings of No. 8 wire. Gondola cars with sides thirty (30) inches high or over, must have six stakes not less than three (3) inches wide by four (4) inches deep on each side of car and the tops of opposite stakes must be held together by two one (1) by six (6) inch boards fastened at each end by means of three ten-penny wire nails, or four strands equal to two wrappings of No. 8 wire.

No. 33. When the length of lumber will permit, it must be similarly loaded in two piles with six stakes on each side of car. For flat cars and gondola cars with sides less than thirty (30) inches high, stakes must not be less than four (4) inches wide by (5) inches deep, and for gondola cars with sides thirty (30) inches in height and over, stakes must not be less than three (3) inches wide by four (4) inches deep in both cases secured as specified in Rule No. 32.

No. 34. Lumber of equal widths must either be lapped or have strips across loads at intervals of not more than thirty (30) inches high, to act as binders.

Orders were issued to agents at certain stations to enforce the new regulations, with the result that cars loaded in the old manner were not accepted by the railroad company.

It is the universal opinion of the lumber trade that the restrictions are an imposition and entirely unnecessary. Hemlock is used very largely for stakes at the present time, whereas the new rules specify that it must never be used and that all stakes must be sound, straight-grained lumber (hardwood preferred). Such a specification will increase the cost of staking a car at least \$3 over the old system. According to the desire of the Grand Trunk management, the shipper of lumber must continue to provide the stakes, which he has no right to do, and at a largely increased cost. But that is not the only hardship. The larger stakes and crossers that are specified will weigh perhaps one thousand pounds, and on this heavier weight the shipper must pay freight charges.

It is difficult to conceive of any advantage to be derived from the use of 4x5 stakes, inasmuch as these would have to be cut down to fit the present car pockets, which are about 3x3. "A chain is no stronger than its weakest link." Wherein lies the philosophy of cutting down a 4x5 stake, equal to 20 inches, to fit a hole about 3x3, equal to 9 inches? The breaking point is at its weakest part, and if increased strength is desired, the railroads should have their cars equipped for 4x5 stakes.

Why the width of crossers should be increased from four inches to six inches is as much of a problem as the stake question.

What the new regulations mean to lumbermen can best be shown by a few figures. Under the new system to stake a car would require 12 pieces 4x5, 12 feet long = 240 feet, and 12 pieces 1x6, 12 feet long = 72 feet, or in all 312 feet of pine or hardwood, which at \$15 per M. would be worth \$4.68. To this must be added the cost of 72 nails and men's time, say 32 cents, making the total cost of staking a car \$5. Under the old system, 12 pieces 2x4, 12 feet long = 96 feet; 6 pieces 1x4 = 24 feet, in all 120 feet of hemlock, at \$12 per M. = \$1.44; twelve 3 inch nails and men's time, 16 cents, or a total of \$1.60. Upon this basis the new rules would impose an additional expense upon lumbermen of \$3.40 for every car of lumber shipped.

Now, as to the motive of the railway company. The most reasonable supposition is

that the management desire to minimize the number of claims for lumber lost in transit. This suggests the question whether the insufficient staking of the cars has been responsible for such losses as have occurred in the past, and to this a negative reply must be given. Is not the reckless manner in which freight is handled the real cause of the majority of claims made upon the railway company? We think so. The carelessness of the railway employees in shunting cars is common knowledge and many instances could be cited where stakes have been thus broken which were perfectly sound and could have been broken in no other way. A Toronto firm recently received a car of 18 ft. hemlock joisting piled in the centre of a 34 ft. car. This left eight feet of empty space on each end of the car, but when it was shunted into their yard the stakes were broken and the load shifted until the lumber struck the car in front of it, about ten feet from where it was originally loaded. In another instance a flat car was shunted while in a lumber yard with such force that the lumber broke the end of a box car and the shippers were obliged to reload the car. Investigation will prove, we believe, that if the employees would exercise greater care in shunting, the 2 x 4 stakes which have been used in the past will amply meet the requirements. And if the shippers are to be compelled to furnish the stakes, why not secure something in the nature of a permanent equipment and have the railways provide some method of returning them to the shippers?

Apropos of this subject, we learn that the Legislature of the State of Georgia enacted a law at last session providing that the railroad companies should equip their cars with standards, and the Georgia Interstate Sawmill Association have decided to institute proceedings to collect \$1.50 from the railroads for every car that the members have been obliged to equip since the enactment of the law.

THE BRITISH COLUMBIA TIMBER LAWS.

As intimated in the April number, the timber laws of British Columbia have been altered in two important respects, this having been accomplished by amending the Land Act. The bill was introduced in the Legislature by Hon. R. F. Green, Commissioner of Lands and Works, and did not become law without opposition. The amendments apply to timber licenses, and, in brief, provide that all special timber licenses which are now in force, or which have been applied for, or notice of which application had appeared in the British Columbia Gazette on or before the fifteenth day of April, 1905, shall be transferable and may be renewed each year for sixteen successive years. Heretofore, under the Land Act Amendment Act of 1903, licenses have not been transferable and were renewable yearly at the discretion of the Commissioner of Lands and Works and subject to such tax and royalty as the Government might impose.

As the champion of the amendments, the Chief Commissioner contended that holders of special licenses had found much difficulty in obtaining the necessary accommodation from

the banks to enable them to carry on their operations, and that the new provisions would improve the situation in this respect, as it made the licenses transferable and renewable. The argument advanced against the changes was that the proposed legislation would prove to be of greater benefit to the speculator than to the legitimate manufacturer. The concensus of opinion, however, was that the bill was a move in the right direction, as it would do away with the double system of holding timber lands which had caused so much confusion in the past. The timber laws of British Columbia have not been satisfactory for years, and if the present amendments should be the beginning of a more stable and definite policy in respect to their administration, they should be welcomed on all sides.

That the lumber trade may know the exact purport of the amendments, we give the main clauses below:

"3. Section 53 of the "Land Act," as enacted by section 8 of Chapter 30 of the statutes of 1903-4, is repealed and the following is substituted therefor:—

"53. (1.) A special timber license for logging purposes shall not be granted for a larger area than six hundred and forty acres of land, which shall be in one block bounded by straight lines drawn to the cardinal points, none of which lines shall be less than forty (40) chains in length, except in cases where such a length cannot be obtained; nor shall the license be granted for a longer period than one year, and the fees payable for such special license shall be as follows: For each license: West of the Cascade range, one hundred and forty dollars; east of the Cascade range and in the electoral district of Atlin, one hundred and fifteen dollars.

"Such license may be granted at the discretion of the Chief Commissioner, and shall be subject to such tax and royalty as may be by this act, or from time to time by any act of the Legislature of the Province of British Columbia, imposed or reserved. Provided that the Chief Commissioner of Lands and Works may, before granting any special license, offer the limits to public competition, when he has reason to believe that the public interests will be served by so doing.

"(2.) All special timber licenses which are now in force shall be transferable and may be renewed each year for sixteen successive years, and the fees for each renewal of any such license shall be paid in advance, and shall be of the same amount as is now paid for such license: Provided that the right of such annual renewal shall not be acquired by holder of any license unless he shall, at the time of applying for the first renewal of his license, have given notice in writing to the Chief Commissioner of Lands and Works of his intention to avail himself of the privileges of this clause. In addition to the royalty which is now reserved by section 58 of the Land Act, there shall be paid to His Majesty ten cents per thousand feet, board measure, upon and in respect to all timber suitable for spars, piles, saw-logs, railroad ties and props for mining purposes, cut and removed from lands comprised within any special license heretofore issued or coming within the scope of this sub-section.

"(3.) All special timber licenses which may hereafter be issued shall be transferable and shall be renewable each year for twenty-one successive years.

"(4.) No licensee who elects to renew his license under the provisions of sub-section (2) of this section, and no person who takes out a license after the passage of this act, shall be allowed to cut or carry away any timber from off any such timber limit unless the said licensee has, at his own expense, had the land surveyed by a duly qualified Provincial Land Surveyor. The Chief Commissioner of Lands and Works may, however, at any time notify the holder of any special timber license to have the land covered by such license surveyed by a duly qualified Provincial Land Surveyor within a time to be mentioned in such notice, and if such land shall not be surveyed within such time, or within such further time as may be granted by the Chief Commissioner of Lands and Works therefor, the holder of such license shall forfeit all his rights to the timber on said land, and such license shall become null and void."

THE SAW MILL HAZARD IN NEW BRUNSWICK.

By PETER CLINCH, Secretary New Brunswick Board of Fire Underwriters.

My experience of steam saws mills is limited to the Province of New Brunswick, a rather small district, but one in which the manufacture of lumber is the principal industry. The mills in this Province are much smaller and very different from those in Western Canada, and this paper must necessarily be taken from a local standpoint.

I have been inspecting mills for about twenty-five years, at first only an occasional inspection, but this year about sixty mills have been dealt with.

The steam saw mill of twenty-five years ago was a framed mill, with shingle roof, the boilers being in the main building, or in a framed boiler house attached. In most cases there was a good brick chimney. There were long shell boilers hung from wooden beams on iron rods. The furnaces were fed on top, and therefore between the boilers, and although the fuel was chiefly edgings, an immense quantity of sawdust had to be disposed of, and this was fed at the back ends of the furnaces, and was frequently piled up until it reached the beams, sometimes being left to dry, there to be used in starting fires the next day. In this way it often ignited, and most of the mill fires were traced to that cause.

These mills generally ran an old-fashioned gang, an edger and trimmer, a lath machine, and sometimes a shingle machine, but hardly ever a planer or box machine, though sugar shooks were sometimes made. These were nothing more or less than $\frac{1}{4}$ in. rough boards, sawn the proper lengths.

The surplus refuse had to be disposed of, and this was usually done in an open burner, from 200 to 500 feet distant from the mill, the edgings being conveyed by an endless chain to the fire, on a wooden conveyor, about 25 feet of the end next to the fire being made of iron.

These mills, as a rule, had no fire protection, except such as was supplied by a small steam pump in the engine room (which was also used for feeding the boilers, the hose generally disconnected), and by barrels of water distributed through the mill and on the roof.

The lumber around the mills was principally spruce deals, and hardly ever burned even when the mills did.

There was no space clause; that part of the continuous pile within fifty feet of the mill paying mill rate, and that from fifty to 300 feet from the mill paying $2\frac{1}{2}$ per cent., with full average clause.

These mills were rated from 6 per cent. to 7 per cent., and were, I believe, not profitable to the insurance companies.

The lumber, however, yielded an immense profit.

Such mills usually caught fire from the boiler house, the fire starting in the sawdust over the opening in the furnaces. They sometimes caught from hot journals and occasionally from torch lamps; but in my opinion the substitution of a detached fire-proof boiler house for the old-fashioned construction relieved the companies of more than one-third of the physical hazard.

There was no such thing as a partial loss, except when a very small fire occurred on the roof.

There are a good many such mills still sawing lumber in this Province, but they are gradually being replaced by a mill built under the Board Schedule.

Before referring to the better class of new mills, I may say that about one-fifth of the lumber cut has, during the last few years, been manufactured by portable mills, which are not, as a rule, insured, but which leave a great deal of refuse behind them, from which fires frequently occur. The lumber sawn by these mills is strewn along the lines of branch railways, and though it consists principally of spruce deals, calls for a higher rate than lumber from 50 to 300, from a 6 per cent. mill.

This portable mill business has been rather unprofitable to the lumbermen engaged in it, and I believe that not one-half as much will be cut by them in the future as has been in the past.

A number of years ago a committee of the New Brunswick Board drew up and adopted a mill schedule,

a copy of which is attached to this paper. It is not altogether original, and it is not claimed that it is the best schedule in use — in fact, it has been altered and revised a number of times, and may be again. It has, however, had a good effect on the mill business, as viewed by the insurance agent. There has been a steady improvement in the construction of the mills since its adoption, though at first it only applied to new mills. One mill owner who was spoken to in regard to mill fires, and who was of the opinion that every steam saw mill burned sooner or later, said, "A man dies and a mill burns"; but a great majority of the best mill owners will say that there is no great physical hazard in a steam saw mill, and that when a mill burns, it is generally, but not always, well sold.

My own opinion is that the physical hazard in a steam saw mill of the better class has been very much exaggerated.

I think the moral hazard is tremendous, and I think this applies more to very highly-rated risks than to those rated moderately. When a man has paid seven or eight per cent. for, say, twenty years, he feels that he is only getting his own money back when the mill burns. I consider this an additional reason for inducing owners to build first-class mills, and for giving them a moderate rate.

I must say that the average mill owner improves his fire protection more with the view of getting a low rate than of putting out fires. He never expects the mill to burn, unless it is set on fire, and there is no schedule that I know of that will draw a fair distinction between the man who really means to protect his mill and the one who can't be made to realize the fire hazard. In such cases the rating officer must be allowed some latitude.

Most of the mills which have been built within the last ten years have brick boiler houses, eight feet detached from the mill, with plate iron roofs, iron rafters and girders, with no wood-work whatever, except what is required to hold the incandescent light wires. There are no openings on the side next to the mill, except for shaft, belt or steam pipes. They have patent furnaces and short tubular boilers, the sawdust being fed on top of the furnace but not on top of the boilers, so that the distance from the furnaces to the roof is much greater than it is with shell or flue boilers, which are much longer and cover the entire furnace. In these patent furnaces only sawdust is used. As a rule, they require less fuel than the old-fashioned kind, and there is still more to be disposed outside the mill.

The quantity of sawdust made largely depends on the kind of lumber sawn, and the thickness of the saws used—for instance, an old-fashioned gang, sawing 1 in. boards, converts over one-fifth of the entire log into sawdust, whereas a stock gang or band saw, cutting deals only, wastes about one-fifth of that amount. Of all the refuse from a steam saw mill, there is none so hard to dispose of as that from cedar shingles. If it is conveyed to the outside burner, it blows all over the mill yard, and if burned in the furnace room, fills the place with dust and fibre. The better way to dispose of this refuse where it is necessary to burn it in the furnace room, would be from a shavings' vault. The difficulty in disposing of saw mill refuse generally can only be safely overcome by steel burners outside the mill. The very best of the mills in this Province are supplied with them, but the greater number still have open burners, and haul away and sell a great quantity of edgings as well.

These open burners are generally more than 300 feet from the mill, but they are sometimes not 300 feet from the lumber, and in some cases are a quite serious exposure.

The danger of fire from hot journals could be almost entirely avoided if such ball-bearing self-oiling journals were used as are found in the most modern grain elevators.

The cut of spruce deals (which are generally piled and sold wet), was this last year about 175 million feet; twenty million feet of spruce boards and scantling were sawn; about ten million laths and staves, 300 million shingles, and about ten million feet of pine boards, which latter are piled and stuck to dry.

The large proportion of spruce deals sawn makes

the insurance on lumber in New Brunswick very different from that in Western Canada.

I do not know of a case where a steam saw mill has caught from the lumber, and in most cases of saw mill fires, the loss on lumber has been very light.

A mill running gangs must be more heavily built than one running rotaries or band saws, and the danger from hot journals is greater in consequence of the continuous shaking of the mill.

In every way the modern mill is a better risk than the mill of 25 years ago, except as regards the lumber sawn. There is each year a little more small lumber cut, and a little more of it stuck; but the improvement often in the mills more than offsets this.

Too little attention is paid to whitewashing, and I am not sure that a greater allowance than the present one should not be made for it in the rate. There are a great many formulas for whitewashes, but the lasting and adhering qualities of the wash are perhaps not of the greatest importance. The whitewashing should be done at least once each year, and ordinary lime wash, with a little salt in it, in addition to being a great non-conductor, is quite good enough to wash down all the dust and cobwebs and cover up some of the oily wood. The inspector can see at a glance if the work has been slighted. Perforated pipe for outside sprinklers (not automatic), and for the inside of boiler houses in places where there is some water pressure, might be used to a greater extent, especially where the roofs are shingled. Even in mills where there is no water pressure, a connection with the engine room pump could be made.

The following might be taken as a standard for a New Brunswick saw mill, only 2 or 3 of the present ones quite filling these requirements, though quite a number approach the standard.

A framed timber-built mill on good foundation, with gravel or metal roof not over two storeys above the basement, with brick boiler house detached at least 8 feet from mill, iron roof, rafters and girders, with no opening on the side next to the mill except for shaft belt or pipe, patent furnaces, tubular boilers and brick chimney. Running band saws or stock gangs, sawing spruce deals, boards and laths only. Whitewashed yearly. Surplus refuse consumed in a steel burner lined with fire-brick and with good spark arrester.

Underwriters' pump in pump house not exposed by mill or lumber, and connected with yard hydrants, stand pipes in mill and outside sprinklers, each hydrant to be in a framed hose house, with an abundant supply of fire hose always attached, a small drip cock being fixed at each outlet to prevent the leakage from destroying the hose, casks and buckets throughout the mill and a good supply of ladders outside. Lighted by incandescent light, and supplied with an approved stationary watch clock.

Oils kept in a brick house not exposing mill or lumber.

A clear space between mill and lumber of 50 feet. This space will appear very small, but when the lumber is spruce deals piled close, the exposure is not great.

The New Brunswick Board Schedule is used for rating planing mills in the absence of something better, but it was not originally intended for that purpose. A few of the saw mills have planers for dry lumber, and dry houses exposing them, but of course these are not in the planing mill class.

In the 4th Quarterly Bulletin of the National Fire Protection Association, Mr. F. J. McFadden has an article on steam jets for dry kilns, and it is surprising that they have not been more generally used in this class of risks, which is so well adapted for them, and on which the rates are so high.

Shingles are now sawn almost exclusively in mills sawing nothing else, and though a few of them are well kept, the average shingle mill is very dusty and requires whitewashing oftener than any other class of mill. There is generally no lumber of any account piled near them, as shingles are usually shipped as soon as sawn, and in no case have I found much exposure from lumber. There is not the same tendency to improve these mills, as they are of much less value; still, some effort has been made in that direction, and I know of one or two particularly good ones.

The mill schedule induces the construction of rather

*Paper read before the Insurance Institute of Montreal.

low-rated mills, and a great many experienced underwriters are of the opinion that no steam mill (not sprinkled) should be written at less than 4 per cent., but I think the Cotton Mill Mutuals have taught us that a highly protected special hazard can be written at a low rate.

Some years ago, when cotton mills were first sprinkled, and were being written by the Mutuals at 1 per cent., about seventy cents being returned in the form of a rebate, I read a letter from a general manager, who was said to have the most extensive knowledge of cotton mills, in which he said that no cotton mill could be written at less than 2 per cent., with or without sprinklers.

NEW BRUNSWICK BOARD OF FIRE UNDERWRITERS.

STEAM SAW MILL SCHEDULE.

Adopted 27th December, 1904.

MAXIMUM BASIS RATE.....	\$10.00
1. If boiler house brick, first class detached with iron roof and girders, at least 8 feet from Mill, with no communication except by shaft, belt or pipes, and no wood-work whatever. (If detached less than 8 feet, or if not up to this standard, allowance to be made in proportion.)	Deduct \$2.00
2. For entire brick chimney.....	“ .50
3. For iron chimney on brick base, 3 feet above roof, or outside of Mill with spark arrester in good order...	“ .25
4. For first-class patent or hard roof..	“ .50
5. For first-class water supply, including force-pump outside of Mill, and worked independently, always ready for immediate use, and not less than 300 feet of 2½ in. hose, with standard threads for iron pipe couplings, attached to hydrant or pump.....	“ 1.00
(If water supply not first-class allowance to be made in proportion.)	
6. If protected by City Fire Department and Waterworks and at least two hydrants within 300 feet.	“ .25
7. If no shingle machine used.	“ .25
8. If Mill whitewashed throughout at least once per annum and certificate supplied.....	“ .25
9. If no open refuse burner, or if refuse disposed of in patent burners outside of Mill.....	“ 1.00
10. Open refuse burner at discretion of Secretary according to exposure to Mill or lumber.	
11. If Mill entirely brick or stone.	“ 1.00
12. For two casks of water in boiler-house, and on each flat of Mill, six round bottom pails in each flat, and casks of water on roof, if shingled ..	“ .50
13. For two ground and two roof ladders on each side of Mill where required.....	“ .25
14. If Mill owner agrees to pay the charge of inspection twice in the year by Board Inspector and to accede to his requirements as to cleanliness, &c.....	“ .25
15. Incandescent Lighting.....	“ .50
16. Watchman with electric watch clock.....	“ .25
1. For planer of dry lumber.	Add 1.00
2. For dry house in Mill.....	“ 1.00
3. For dry house exposing Mill.....	“ .50
4. For oil room or oil kept in quantity in Mill.....	“ .50
5. Wooden chutes from Mill floor to top of furnace.....	“ .75
6. If refuse or lumber piled within 50 feet of Mill.....	“ 1.00
7. If less than ten per cent. of the total Mill Insurance attached to the Boiler House, and contents	“ .25
8. Exposure charges will be made at discretion of Secretary.	

P. S.—For approved equipment of automatic sprinklers a deduction of 33 1-3 per cent. from the ascertained rate will be made.

SAW MILL SCHEDULE.

WHITEWASH CERTIFICATE.

THIS IS TO CERTIFY that the Steam Power Saw Mill owned by..... was thoroughly Whitewashed within the twelve months preceding..... Owners. Dated.....190

F. L. Arnett, of Souris, Man., has enlarged his planing mill and installed new and modern machinery.

AMERICAN NO. 1 BAND RIP SAW.

The machine shown herewith is designed for ripping either hard or soft woods, with ample power on both blade and feed works for any reasonable demand. The use of this machine allows the ripping of thicker stock than can be accomplished on the circular rip saw, and permits the work to be done more rapidly with less kerf removed. The frame is cast hollow, with heavy cross struts and with wide foot flanges which extend beyond the lower wheel,

The front top roll is driven, while the back one is a press roll. The pressure of both of these rolls is governed by springs. They are hung in separate swings, so that they will yield for any variation in thickness of lumber, and are attached to the head guide bar, which is indexed to show the height from the top of the table to the bottom of the rolls, so that the operator can quickly adjust for different thicknesses of stock. This guide bar is counter-balanced so that it can be easily adjusted. The feed rolls can be started or stopped by

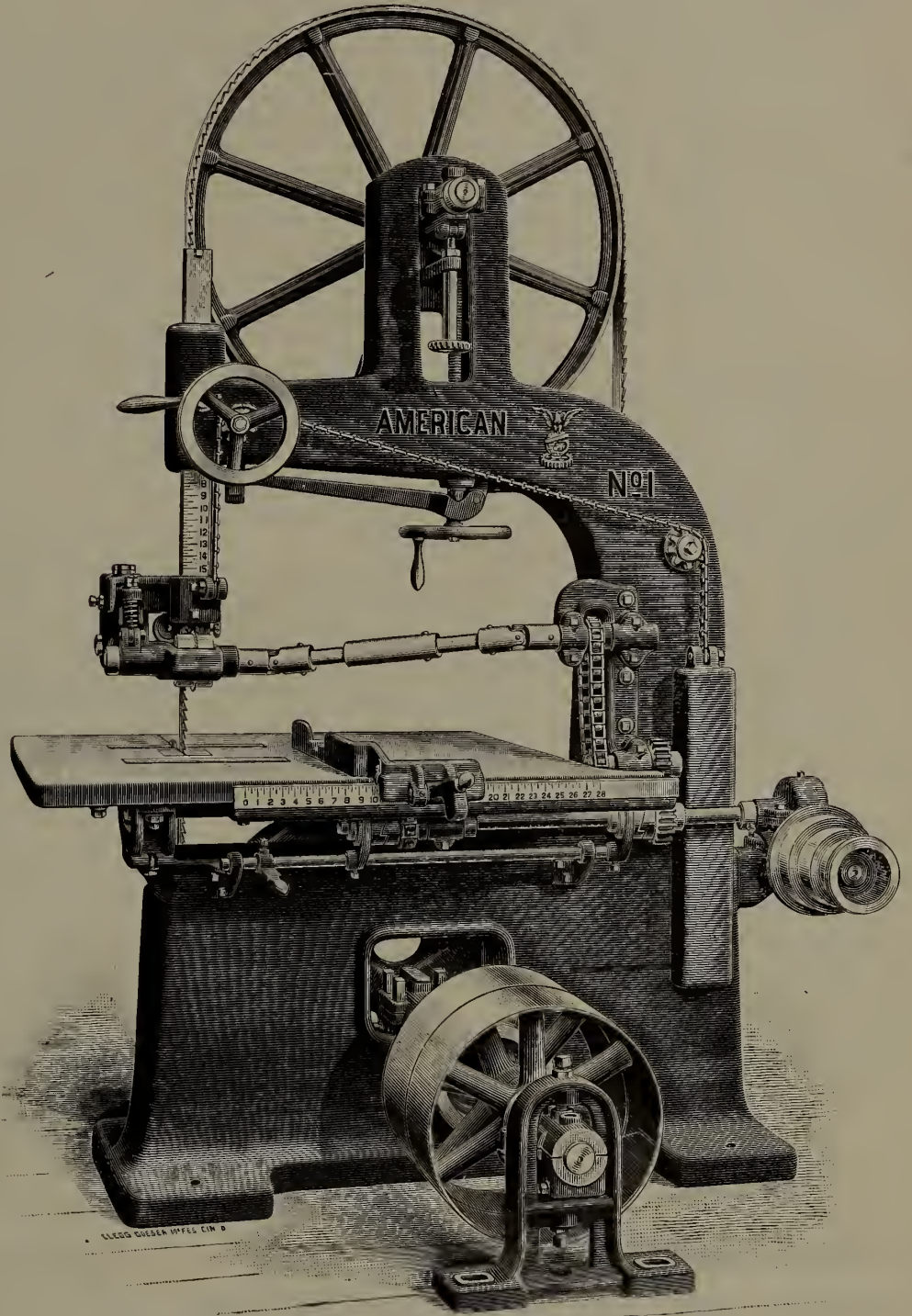

AMERICAN NO. 1 BAND RIP SAW—AMERICAN WOODWORKING MACHINERY COMPANY.

giving a broad base, which, when properly set, prevents vibration when the machine is run at full speed. The shafts are of hard steel, accurately ground, of large diameter and run in long self-oiling boxes. The lower shaft is supported by three bearings, while the upper one has two, all lined with the best babbitt metal. The wheels are 40" in diameter, of the form and dimensions which had been found correct by long experience in the construction of band sawing machines.

The feed works are driven by a belt drive. The two driven rolls in the bed are 5" in diameter.

changing the small lever under the table independent of the main drive.

The table is of iron, 46" wide, 44" long, and is fitted with self-locking gauge, which is operated by simply raising the handle, which instantly releases the gauge; it can then be easily moved to any desired point, when the lever is allowed to drop into position, holding the gauge absolutely rigid.

There are three changes of feed, namely, 60, 105 and 150 lineal feet per minute. Capacity, 15" vertically and 28" horizontally.

Further particulars may be obtained by addressing the American Wood Working Machinery Company, 136 Liberty Street, New York.



A CONCATENATION AT MIDLAND.

The lively town of Midland, Ont., desires a concatenation, and the invitation extended by Mr. Frank Moores has been accepted. June 30th has been selected as the date, and as it falls on Friday and the following Saturday being Dominion Day will be a public holiday, an exceptional opportunity will be afforded Hoo-Hoo members from all parts to join in the festivities. The local Hoo-Hoo are very enthusiastic, and as Midland is a large lumbering centre and particularly interesting in the summer time when the mills are in operation, an extremely pleasant time may safely be counted upon. Doubtless there will be a large-class of eligibles.

THE HOO-HOO ANNUAL.

The fourteenth annual of the Concatenated Order of Hoo-Hoo is to be held beginning September 9, 1905, at Portland, Oregon. According to all accounts, it bids fair to be one of the largest and most successful annuals ever held. Out on the west coast the members are making great preparations for it.

The Official Souvenir Book for this fourteenth annual is now in course of preparation. It will be published by Mrs. Edna B. Jones, who had charge of the book last year and made it such a distinct success. It will be gotten up in excellent style—the printing, paper, engravings, etc., being of the best in every particular. The contents will be of a character specially interesting to Hoo-Hoo everywhere. There will be contributions by prominent members of the order and leading writers, together with much that will pertain particularly to the west coast and its lumber interests.

The portrait gallery will contain full page pictures of the officers of Hoo-Hoo—the Snark, the House of Ancients, Supreme Nine, Vicegerents and other prominent members of the Order.

LUMBER INSURANCE.

The question of insurance is one that is continually presenting itself to lumber dealers and manufacturers throughout Canada and the United States. That insurance is essential to any well regulated business goes without saying, for besides the necessity of protection against personal loss it is required as a security of interest by firms dealing on a credit basis and by all credit agencies, none of whom cares to deal freely with, or give unqualified good name to any concern not possessing some indemnity for serious loss.

For a number of years it has been the consensus of opinion in the lumber trade that their insurance rates here too high, and long continued protests finally took effect in the shape of an investigating committee, which went carefully into the question. Their findings were in general that the insurance companies had freely taken advantage of the fact that insurance is a necessity, and for years have closely followed the plan of "charging what the traffic would bear". Some lines of business have been so liable to large losses as to be profitable by the narrowest margin only. The rates on these already being as high as there was any hope of collecting, the easy expedient was adopted of charging more than was necessary on those classes of risks which from year to year had yielded a good return. The experience of old policy-holders shows that a general raising of rates on every business and in every location follows immediately upon a disastrous conflagration which has brought unusually heavy losses to the insurance companies. In either case it is the same story, overcharging the safe business to make it pay the losses on the unsafe.

The committee further found that among those most generally discriminated against was the lumber business, the rates charged on that class being far in excess of the proportion of losses which the insurance companies suffered on it. This led to the organization, one by one, of that group of three powerful companies now writing lumber and woodworking risks in all parts of Canada and the United States, namely, the Lumber Insurance Company of New York, the Lumber Underwriters, and the Toledo Fire and Marine Insurance Company. Situated as they are, the first and second at 66 Broadway, New York, and the last at Sandusky, Ohio, they are geographically well situated to reach the trade.

They are organized and conducted on a plan which enables them to save money for the trade. In the first place they dispense, so far as possible, with agents, and by doing business direct with the property owners save a great deal which with the other companies is spent in commissions. The direct method is found by their policy-holders to afford other advantages, since it brings into intimate business relations both parties to the insurance contract. The fact that the three companies are all owned and managed by lumbermen makes it easy to arrive at a mutually satisfactory arrangement, for the men in the offices are so well acquainted with the needs of the trade that they can readily and intelligently respond to any requests or

suggestions made them by those with whom they are doing business.

The manager of one of the companies in talking to the writer outlined to him the conservative plan followed by the three companies, which frees them, within the range of all human probability, from the dangers of being crippled or ruined by a large conflagration. The plan consists in avoiding an overloading of any of the companies on any one of the large lumber districts which are, in the words of the insurance man, "subject to a single conflagration."

The advantages to the policy-holder of such conservatism on the part of the company whose policy he holds is evident. There is no need to fear that any one of the three companies in question will be forced to the wall by any of the great fires such as have happened in several cities of Canada and the United States in the past year. No company could adopt a surer way of protecting its own interests, and through its own those of its policy-holders, than this big group now has in force, and the advantage to the assured is thus doubled, since the conservatism not only makes the indemnity surer, but aids in making possible the lowering of rates.

Believing that the trade wishes the very best of insurance the organizers of those companies decided to depart from the time-worn mutual plan, and avoid that feature of somewhat doubtful desirability which attaches to a mutual policy in the shape of assessment liability. Two of the three companies, the Lumber Insurance Company of New York and the Toledo Fire and Marine Insurance Company, offer regular stock company policies, which are issued under the supervision of the states of New York and Ohio respectively. The third company, the Lumber Underwriters, is a Lloyds, with its policies backed by the individual responsibility of the Underwriters. Its board of underwriters being composed of seventeen men prominent in the lumber trade of the United States and Canada, and having an aggregate wealth of many millions of dollars, the soundness of their indemnity is beyond question.

The strength of the group is such that the three companies can carry a large line on any good risk. Acting independently or through some one of the three they have in the few years of their operation invaded every part of Canada and the United States where there is lumber to be insured. They have made the arrangement of the business easy for the assured and given satisfaction at all times. They form an aggressive trio, and are always to be found active wherever there is a fight for business.

CALIFORNIA EXCURSION.

The Chicago, Union Pacific and North Western line runs through first-class pullman and tourist sleeping cars to points in California and Oregon. Personally conducted excursions from Chicago every week. Lowest rates, choice of routes. Finest scenery. Special attention given to family parties. For maps, illustrated folders and rates, address B. H. Bennett, general agent, 2 King street, Toronto, Ont.

SPECIAL TO LUMBERMEN, MINERS AND RAILWAY CONTRACTORS



We are Manufacturers of

**MINCE MEAT, BAKING POWDER,
COFFEE, SPICES, FLAVORING
EXTRACTS, MUSTARDS, &c.**

And all kinds of Grocers' Sundries
for Camp Use.

Mince Meat put up in 75 pound Tubs, ½
Barrel about 300 pounds, Barrels about
600 pounds.

Special Attention Given to Mail Orders

**The Capstan Manufacturing Co., TORONTO,
ONT., CAN.**

CANADIAN OIL CO. LIMITED STRACHAN AVENUE TORONTO, ONT. TO LUMBERMEN THE DOMINION OVER: OUR TRADE WITH SAW-MILLS

Has been large and satisfactory. We again solicit your orders for the season of 1905.

Our Agents will call with "STERLING"

Cylinder, Engine, Dynamo, Machine, and SPECIALTY Oils, Greases, Packing, Waste, Babbit Metal, Ready Mixed House Paints, Varnish, Red and Black Roof Paint, Smoke Stack Black for Boiler Fronts and Saw Mill Refuse Burners, White Lead, etc.

BRANCHES: Petrolia, Ont. Hamilton, Ont. Montreal, P. Q. Vancouver, B. C.
London, Ont. "Soo," Ont. Winnipeg, Man. St. John, N. B. C.
Halifax, N. S.

'STERLING'
OIL
'STERLING'
OIL

CANADA LUMBERMAN

AND WOOD-WORKER

WEEKLY EDITION

The Lumberman Monthly Edition 44 pages } \$1.00 PER YEAR {The Lumberman Weekly Edition every week.

THIS PAPER REACHES REGULARLY THE PRINCIPAL LUMBER MANUFACTURERS AND DEALERS THROUGHOUT CANADA, AND WHOLESALE BUYERS IN GREAT BRITAIN, THE UNITED STATES, AND OTHER FOREIGN MARKETS.

VOL. XIII.

TORONTO, MONTREAL, WINNIPEG, MAY 3, 1905

No. 14

CANADA LUMBERMAN.

PUBLISHED BY

The G. H. Mortimer Publishing Co'y
of Toronto, Limited

Confederation Life Building - TORONTO.

Branch Offices:

38 ALLIANCE BUILDING, MONTREAL
720-721 UNION BANK BUILDING, WINNIPEG.
22 GREAT ST. HELEN'S, LONDON, E. C.

The Weekly Lumberman - Published every Wednesday, contains reliable and up-to-date reports of market conditions and tendencies in the principal manufacturing districts and leading domestic and foreign wholesale markets. A weekly medium of information and communication between Canadian timber and lumber manufacturers and exporters and the purchasers of timber products at home and abroad.

The Monthly Lumberman - A 44-page journal, discussing fully and impartially subjects pertinent to the lumber and wood-working industries.

WANTED AND FOR SALE

Advertisements will be inserted in this department at the rate of 15 cents per line each insertion. When four or more consecutive insertions are ordered a discount of 25 per cent. will be allowed. This notice shows the width of the line and is set in Nonpareil type; 12 lines make one inch. Advertisements must be received not later than 4 o'clock p. m. on Tuesday to insure insertion in the current week's issue

EXCELSIOR WOOD WANTED - PEELED basswood or clear spruce. RANKIN AND CO., Dundas street, Toronto. Telephone.

SPRUCE - LONDON MAN LEAVING TORONTO for London, would like to take up an agency to sell spruce. Has a large and sound connection all over London. Apply Box 213, CANADA LUMBERMAN, Toronto, Ont.

SLACK, COOPERAGE PLANT AND TIMBER

FOR SALE

SAW, STAVE AND HOOP
MILLS COMPLETE

- AND -

600 Acres Timber Lands

of which 500 acres are virgin timber composed chiefly of Elm, with a good percentage of Basswood, White Ash, Hickory, Red Oak and Soft Maple. Estimated at 3,000,000 ft. Within 1 1/2 miles of station on line of Michigan Central Railway. Mill now running. Good level roads for trucking logs to mills. Other blocks of timber available. Good reasons for selling. Address reply to "Staves and Hoops," care of CANADA LUMBERMAN, Toronto, Ont., for full information of property.

FOR SALE - 1" to 3" DRY MAPLE LUMBER. Special price made on 2". J. S. GOLDIE, Cadillac, Mich.

WANTED - CEDAR TO BE SAWN TO order. Dry 1" and 2" Hemlock. 1", 5/4", 6/4" and 2" Black Ash. R. E. KINSMAN, Hamilton.

WANTED - TEN THOUSAND CORDS Hard and Soft Wood; also same quantity of Slabs. SIMCOE WOOD AND LUMBER CO., 52 Yonge Street Arcade, Toronto.

FOR SALE - THE CUT OF 250M FEET OF Oak; 250M feet Pine, also some Basswood and Hickory. This can all be cut to order. Have also 600 cord wood ready to ship. Address HILL & KATZ, Caledonia.

SAW MILL IN VANCOUVER, ANNUAL turnover fifty thousand dollars, for sale; price twenty six thousand; terms can be arranged and fullest particulars given by THE LOCATORS, of Winnipeg, Manitoba.

SAW MILL AND TIMBER LIMIT IN Manitoba for sale, yielding annual turnover of \$25,000. Price of Saw Mill, \$2,500, in four payments; limit 200,000 cords, \$10,000, \$5,000 cash, balance easy; teams, horses, sleighs, etc. THE LOCATORS, 62 and 63 Merchants Bank Building, Winnipeg, Manitoba.

TIMBER LIMIT FOR SALE IN BRITISH Columbia, eight square miles, fifty per cent. cedar, 25 per cent. fir and pine and 25 per cent. spruce. Limit situated on Columbia River, with a frontage of ten miles; one hundred and twenty five million feet. Level ground. Full particulars on application to THE LOCATORS, Winnipeg, Manitoba.

FOR SALE. - SAW MILL MACHINERY, nearly new, capacity 15,000 ft., 100 M feet hardwood logs, 300 M feet hemlock logs, three million feet hemlock and hardwood timber, 1,000 cords bark, 30,000 cords wood, complete logging outfit, quantity shingle bolts at mill and in bush. No dues. Close to G.T.R. Good timber locality. Reason for selling, failing health. For price and terms apply to Box 194, CANADA LUMBERMAN, Toronto, Ont.

CANADIAN TUGS FOR CHARTER FOR SEASON 1905

Tug Florence - Engine fore and aft compound 18 1/2" x 36" x 26. Large Scotch Boiler 12 1/2" x 1 1/2" and easy steamer.
Tug Home Rule - Engine High Pressure 22 1/2" x 24". Fire Box Boiler 8' x 14.
Tug Christian, S.J. (American) - Engine High Pressure 19" x 20". Fire Box Boiler 6 1/2' x 12'.
For further information address HACKETT TUG LINE, Amherstburg, Ont.

FOR SALE - FOR IMMEDIATE SHIPMENT

300M ft. winter cut Basswood 1".
200 " " " B. Ash, 1" and 2".
500 " " " S. Elm, 1".
100 " " " H. Maple, 1".
300 " " " Red Birch, 1", 2", 3" and 4", and Squares.
Box 111, CANADA LUMBERMAN, Toronto.

FOR SALE

TENDERS WILL BE RECEIVED UP TILL June 15th, 1905, for saw mill and timber limits, consisting of Pine, Birch, Red Oak, Maple and Hemlock, together with water power, 200 h.p. developed. This is a choice site for all kinds of wood working factories. Power can be increased to 1,500 h.p. Terms cash. The lowest or any tender not necessarily accepted. Apply to

HARRIS & COMPANY,
Day Mills, Ont.

WANTED - ALL PULP MILLS AND PULP WOOD Companies to look up page 7 monthly issue, which is bound to interest you.

FOR SALE - ABOUT 5000 PCS. CEDAR Railway Ties. Delivery C. P. R. or G.T.R. For particulars apply to A. McDONALD, Peterboro.

FOR SALE - MACGREGOR GOURLAY 36" Circular Resaw, first class order, with saw and counter shaft complete. JAMES HARRISON'S PLANING MILL, Burlington, Ont.

600 ACRES TIMBER LAND IN PARRY Sound district; birch, hemlock, elm and spruce; well timbered; good public road through lots; short haul to station. For particulars apply Box 185, Orillia.

FOR SALE

100 M. FT. INCH DRY BASSWOOD Write Box 58, Smith's Falls, Ont.

HAVE YOU ANY STOCK WHICH YOU wish to sell? If so, make the fact known to probable buyers by placing an advertisement in the Wanted and For Sale Department. Address, CANADA LUMBERMAN, Toronto.

CEDAR FOR SALE

10,000 PIECES ROUND CEDAR, 8-16 AND 25 feet long, on the Vermillion river. Can be delivered at Spanish boom. Also Cedar, Pine and Spruce lumber for sale here at Larchwood on C. P. R. JAMES MCCREARY.

POSITION WANTED - AS LUMBER SALES- man in the States or Canada; 20 years experience, good connections in all kinds Southern or Canadian Hardwoods, also Georgia Pine, White Pine, Lath and Shingles; A 1 reference if required. Address "Salesman," care CANADA LUMBERMAN, Toronto.

TO RENT.

A WELL EQUIPPED PLANING MILL AND Lumber Yard, in a thriving town in Western Ontario, with a good surrounding country, and good facilities for getting in lumber by water or by rail. Only one other yard in same line of business. Satisfactory reasons for wishing to rent. Apply Box 212, CANADA LUMBERMAN, Toronto, Ont.

WANTED.

POSITION AS MANAGER OR ASSISTANT Manager of Lumber Business in West by young man of good character. Applicant is thoroughly acquainted with the business, accurate on estimates and well adapted to assume position which demands executive ability and tact. Would make employer's interests personal and seek to merit his fullest confidence. Apply to S. L. R., care of CANADA LUMBERMAN, 720 Union Bank, Winnipeg.

FOR SALE

75 M Log run Dry Pine, 1" and 2".
100 M " " Birch 1", 1 1/2", 2" and 3".
200 M " " Red Oak, 1", 1 1/2" and 2".
F.O.B. cars Dayton, or vessel at Thessalon. Apply to

HARRIS & COMPANY,
Day Mills, Ont.

About 2,000,000 feet of logs at Cape Chin, Ont., were destroyed by fire last week, the losers being Robert Watt, Kastner & Company, J. P. Newman, George Neiberger and Warton Lumber Company. About 30,000 posts owned by T. J. Austin, Detroit, were also burned.

CURRENT TRADE CONDITIONS.

ONTARIO.

The lumber market has a most healthy appearance. The spring demand is developing as largely as was expected, and the outlook is for a very active season. Prices continue firm, with no decided tendency either to recede or advance, but it may be said that present conditions favor the seller on account of the extensive building operations in Toronto and to a lesser degree throughout the province. There is certain to be a very heavy consumption of lumber this year and it would not be surprising if a shortage should develop in some classes. The mills are practically sold out of dry stock and considerable of the new cut has been contracted for. Mill culls and the lower grades continue to occupy the strongest position, but hemlock is also exhibiting an exceptionally good tone. The manufacturers are realizing higher prices for their stock than ever before, and dealers who earlier in the season entered into contracts based on the prices then ruling are finding difficulty in purchasing the lumber at a price which will give them a margin of profit.

Most of the drives have commenced, but low water in the northern parts of the province promises to result disastrously unless there should be heavy rains in the near future. There is very little snow in the woods and the rain-fall this spring has been exceptionally light. If any quantity of logs should be hung up, higher prices for white pine lumber may be expected.

Since writing the above, it is learned that rain has fallen north of Sudbury, and that the drives in that district are now moving satisfactorily.

QUEBEC AND NEW BRUNSWICK.

The lumber market in the Maritime Provinces is at a standstill owing to the uncertainty regarding the log drives. The outlook is very gloomy on the St. John, Miramichi, Tobique and Aroostook rivers, and unless there should be heavy rains in the near future, the logs are almost certain to be hung up. This will mean considerably higher prices for lumber. The present position of the market is very strong. There is a scarcity of deals on the St. John and it is doubtful if a couple of car loads could be got together. Considerable quantities are held on the north shore for shipment upon the opening of navigation. At the present time deals are worth \$13.50 per thousand f.o.b. St. John, a dollar more than three months ago. There is a strong demand for American spruce deals, which have

advanced in price during the past fortnight.

The cedar shingle market is much improved. Offerings by the small mills are lighter and higher prices are established. Extras for Boston delivery are quoted at \$3.40, and clears at \$2.85 to \$2.90, with the supply of all standard brands comparatively light.

MANITOBA AND BRITISH COLUMBIA.

The expected heavy ordering of lumber from the North-West and Manitoba markets has not materialized, and shipments up to date are below what was expected. The manufacturers are carrying heavy stocks and are prepared for a rush of orders should they come. The mills on the Coast and in the Mountain district of British Columbia are now so numerous that they can take care of nearly double the trade which is now offered. There is a large influx of settlers into the prairie region, but up to date their requirements of British Columbia lumber have been limited this year.

The shingle situation is much improved. For the past six months the market has been in a demoralized state. Owing to the severe competition among the different mills in the province, prices fell below cost and some of the mills went out of business or into the hands of the sheriff. Some weeks ago the manufacturers got together and agreed on a list which will give a fair profit, and it is thought that, after the severe lesson they have had, the list prices will be adhered to. Orders are coming in fairly well and the outlook for a good season's business is promising.

A number of new logging camps have been opened up, and the supply of logs for the season promises to be ample. Wages are very high, which makes the price of logs about \$5.50 to \$6.00 net at the camp, or delivered at the mill \$7.50 to \$8.00.

Owing to the cheaper grades of lumber from the American side cutting into the North-West market, only the better class of logs are being taken out, as it is almost impossible to find a profitable market for the lower grades of lumber.

UNITED STATES.

The position of the lumber market is entirely satisfactory. Practically all classes

of lumber are moving in large volume, while the southern pine business is almost booming. Reports in respect to white pine are much better than one year ago, stocks are not heavy, and prices are higher. The demand is making it compulsory upon dealers to accept the manufacturers' prices, with the result that advances have been made at some of the wholesale points. The great activity in building is consuming a vast quantity of lumber and the requirements of the railroads is also a very considerable factor. The supply of spruce is scarcely equal to the demand. Hardwoods are active, with birch in exceptionally good demand. Ash and elm are also moving in liberal volume, but basswood is lagging. There is a steady call for maple, but prices in the Saginaw Valley show an easier condition, as log run has been purchased as low as \$14.50.

Lath continues to exhibit strength, No. 1 white pine selling in Chicago at \$4 and No. 2 at \$3.75. The shingle market is showing a better tone, due to increased consumption. White cedars have advanced 15 cents within the past two weeks.

GREAT BRITAIN.

Lumber prices in Great Britain have undergone no important change during the past week. The failure of a large Nottingham firm, of which several large importers are creditors, has caused an uneasy feeling in the trade, particularly when considered in conjunction with the recent embarrassment of a timber importing firm in Manchester. Apart from this feature, however, the market is in a healthy condition and deliveries from the docks are being made in large quantities. Pine prices are barely steady, but spruce shows an advancing tendency. At a recent auction sale in London 3x9 inch third quality Montreal spruce regulars brought £8 15s per standard, while 3x9 inch first, second and third quality, from Halifax, N.S., brought £8, and 3x7 inch £7 5s. The importing trade are now accepting the view that the export of spruce from Canada will be very light this year, and that this condition is likely to bring about higher prices.

STOCKS AND PRICES.

The city of St. John, N.B., will purchase 3,500 yards of paving blocks at 50 cents per yard.

The W. C. Edwards Company will supply the lumber required this year by the Ottawa Improvement Commission.

J. T. Scanlan has secured the contract for supply of white pine and spruce lumber required by the Road Department of the city of Montreal.

The Hanbury Manufacturing Company have purchased the stock of lumber carried at Brandon, Man., by the Rat Portage Lumber Company.

The Alex. Gibson Railway & Manufacturing Company have about 2,000,000 feet of spruce deals of this season's cut loaded on scows at the mouth of the Nashwaak river, N.B.

About 280,000 feet of lumber cut by Crain Bros. was sold last week at Carleton, N.B., at auction by virtue of a bill of sale given to George McKean, of St. John. It was purchased by C. E. Gallagher, of Bath, for \$1,100.

The first log raft of the season came down the St. John river and reached Springfield, N.B., last week. It consisted of ten joints of spruce and was brought in by Gordon Grant, of Southampton. A run of bank logs is expected this week.

The Alma Lumber & Shipbuilding Company will saw about 3,000,000 feet of lumber at Alma, N.B. Linton Tingley will cut about 500,000 feet of deals. The prospective cut of the mill of C. T. White, Point Wolfe, N.B., is 3,000,000 feet.

The Fernie Lumber Company, of Fernie, B.C., have sold their entire cut for the season to Christie & Company, wholesale dealers, Winnipeg. The transaction also includes the stock of lumber now on hand, which will bring the total up to at least 4,000,000 feet.

NEW LUMBER ASSOCIATION IN MONTREAL.

The newly formed lumber branch of the Montreal Board of Trade held its first meeting in the Board of Trade committee room on May 1st, when by-laws were adopted, officers were elected, and a number of matters of importance to the lumber trade were considered.

The name decided upon for the association is The Montreal Lumber Association of the Montreal Board of Trade.

The association starts out with splendid prospects of proving of great advantage to the lumber trade. There

W. C. CRAWFORD

Tilbury Ont.

Manufacturer of . . .

Handles—Axe, Fork, Pick, Etc.

Also Hard and Soft Wood Heading and Red and White Oak, Maple and Elm Lumber.

Can supply Second Growth White or Red Oak squares up to 38 in. long in large quantities.

A SPLENDID ROUTE.

The Wisconsin Central Railway is justly termed the "Sportman's Line" because it reaches into and through the very heart of the choicest hunting grounds in America.

The very best wild fowl shooting of the entire North is reached ONLY by this line. Hundreds of beautiful lakes abounding in wild rice and celery attracts myriads of ducks and geese and afford the finest kind of cover and the choicest shooting to be found the country over.

The Wisconsin Central Railway caters especially to the sporting public and during the various seasons for hunting and fishing furnishes daily information to its patrons as to local conditions anywhere along its lines upon application to the nearest ticket agent. It also arranges its train service with special reference to the convenience and comfort of sportsmen, and its employes are constantly on the alert to make travel over their lines pleasant and comfortable.

This line offers the best route between Chicago, St. Paul, Milwaukee, Minneapolis or to Lake Superior points via Ashland, Wisconsin.

Information given by addressing—

JAS. C. POND, Wis. Cent. R. R. Milwaukee,

JAS. LUNNY & CO.,

HINTONBURG, ONT.

DIMENSION
TIMBER

In Spruce, White and Red Pine, up to 40 feet.

In Douglas Fir, up to 90 feet.

Every inquiry receives our Prompt attention.

Write for quotations. B. C. Cedar Shingles

SASH - DOORS - BLINDS

WOODS & SPICER, Limited

.....MANUFACTURERS OF.....

BRITISH COLUMBIA RED CEDAR SHINGLES

Capacity 100 Million a Year.

We have had over 15 Years Experience, and are not Asking our Competitors for any Pointers as to Quality.

Wire Your Orders at **OUR EXPENSE** to Agents, or to us at **VANCOUVER, B. C.**

KNIGHT BROTHERS CO.
Burk's Falls, Ont.

KILN-DRIED BIRCH FLOORING

Send for Catalogue
* * * Samples by Mail

KNIGHT BROTHERS CO.
Burk's Falls.

Keenan Bros., Limited

Owen Sound, Ont.

HARDWOOD, HEMLOCK AND PINE LUMBER

We carry a full supply of native Hardwoods always on hand and solicit your inquiries. At the present time we have piled at outside points about 2,000,000 feet of Hardwoods, and about the same quantity of Hemlock and Pine piled here in Owen Sound, and we should be able to interest you if in the market.

**WILL MAKE SPECIAL PRICES ON
BROKEN LOTS AT OUTSIDE POINTS**

Planing and Matching

—IN TRANSIT—

S. POMEROY, Orillia

PLANING, MATCHING, RESAWING,
SIDING, FLOORING, MOULDINGS

in Car Lots.

Factory near Station.

Write for Prices.

Phone 113

MASON, GORDON & CO.

WHOLESALE TIMBER

Montreal, Quebec

Eastern Agents The B. C. Mills, Timber & Trading

Co., Vancouver, B. C.

DOUGLAS FIR Timber in any size or length supplied

WRITE FOR PARTICULARS AND QUOTATIONS.

EVERYTHING IN LUMBER AND TIMBER

DRESSED AND IN THE ROUGH

BULMER, McLENNAN & COMPANY

MONTREAL, QUE.

Office and Yard, 571 DORCHESTER ST.

P.O. Box 116

are already 30 members enrolled, comprising almost all of the more important firms connected with the lumber business, either in manufacturing or handling lumber.

The officers elected will hold office until the annual meeting, which will be held in December. These officers are as follows:—

President—J. T. Marchand, of J. T. Marchand & Company.

Vice-president—E. M. Nicholson, manager of the McArthur Export Company.

Treasurer—Stanley Barker, manager Robert Cox & Co.

Other members of the executive committee—W. J. Brennan, of W. & J. Sharples; W. T. McLaurin, of McLaurin Bros.; J. H. Redfern, of J. K. Ward & Co., and Wm. Williamson, president Laurentian Lumber Company.

The following were present at the meeting:—A. F. B. Austin, W. J. Brennan, F. W. Cotter, Wm. Duncan, Geo. Esplin, W. K. Grafftey, J. T. Marchand, W. T. McLaurin, E. M. Nicholson, Martin Power, Geo. A. Scott, Wm. Williamson.

BRITISH COLUMBIA LETTER.

(Correspondence of THE CANADA LUMBERMAN.)

VANCOUVER, B.C., April 24th, 1905.—Conditions in the lumber industry in British Columbia are more satisfactory this spring than they have been for a considerable time. Logging is active, and from \$5 to \$7 is being offered at the camp. Loggers are beginning to realize that this is the right way to sell logs, instead of hawking them around to mills, with a prospect of considerable deterioration in

the process. That price is considered good, and for cedar it is higher. The demand for lumber is improving, and many of the mills are working full time. Prices are unchanged, and at present are lower from \$1 to \$2 per thousand than what they were previous to the ruinous depression of last year. In short, all round the business is good, and a continuation of it will do something toward setting some of the mills more firmly on their feet than they have been for quite a time. In the interior small concerns are still suffering, many of them being on the verge of bankruptcy.

The establishment of Mr. John Hanbury's large planing mill at Elko will assist the smaller mills. These have been unable to maintain sellers in the Northwest market, owing to limited financial resources, and sometimes have found the disposal of their product rather slow. It is Mr. Hanbury's intention to handle the cut of the small mills. This will afford them a steady and reliable market and will enable them to save expense for machinery to dress the lumber, besides insurance. This idea was suggested some time ago, and is now being carried into execution.

Mr. Walter Scott, M.P. for West Assiniboia, was in Vancouver last week, but only for a day. He made the same old statement in regard to the duty on lumber, that if it were granted the prices would be increased accordingly. Although this has been denied by the deputation that interviewed Sir Wilfrid Laurier and the members of the Government, Mr. Scott still quotes it, and has reiterated it in the

interior. Prominent lumber manufacturers endeavored to see him while in the city to put him right on this question, but he registered from another town in the Territories, and remained secluded while here.

Mr. J. B. Miller, president of the Ontario Lumbermen's Association, was in the city last week. He was returning from a trip to California, and was accompanied by his wife and mother.

On Vancouver Island the lumber business is looking up. The Chemainus mills have started their night shift, a resurrection of the prosperity of old times. The Ladysmith Lumber Company is to erect another mill with a capacity of 50,000 feet per day. On the west coast there are signs of activity, the timber there being of good quality.

It looks as if the test case regarding the export duty on logs will at last come before the courts. Some of the big companies have been wishing the Government to take this matter up for some time, and have exported contrary to the Act, in the hope that there would be a prosecution, when the points of difference could be settled by the courts. It has been long contended that the amendments to the Land Act in respect to prohibiting the export of timber from certain provincial lands were invalid. In the present instance a boom of the E. K. Wood Lumber Company, of Bellingham, was seized by Timber Ranger John Murray, the logs having been taken off deeded lands, no tax having been paid.

Mr. E. K. Forster, of Cranbrook, and Mr. J. McKinley, of Winnipeg, have joined Mr. W. Wardrope in his sawmill enterprise at Sparwood, and have taken a large financial interest. The former will have charge of the mill and the latter of the bush work.

The mill of the Moyie Lumber and Mill-

ing Company has been taken over by H. Cameron and A. P. Stephenson, who are offering it for sale. Failing to receive satisfactory offers they will operate it themselves.

The Cleveland-Sarnia Saw Mills Co., Limited.

Manufacturers and Wholesale Dealers in

Timber, Lumber, Lath and White Pine Shingles

Special Bills Cut to Order in White Pine, Norway and Fir, any length from 10' to 60' long.

—SARNIA, ONT.

M. & L. Samuel, Benjamin & Co. 503 Temple Building, Toronto.

EXPORT DEPARTMENT.

Correspondence solicited with exporters of wooden goods, such as Sanitary Woodenware, Broom Handles, Fork and Shovel Handles, Turned Goods, etc. Payments made on receipt of Bill of Lading at Toronto. European House, SAMUEL SONS & BENJAMIN, 16 Philip Lane, London, Eng.

J. B. Farwell & Son
CONTRACTORS AND DEALERS IN . .

Canadian Cedar Telegraph, Telephone and Electric Light Poles

Bancroft, Ont., and Oswego, N.Y.

FOR SALE

Exceptionally good Birch and Hemlock Lumber f.o.b. car South River Station. Mills at Midford (Eagle Lake,) Ont.

THE ROBB LUMBER CO., LIMITED
Guelph, Ont.

C. S. POWELL & CO. Lumber Exporters

604 Temple Bldg., TORONTO and at NEW ORLEANS, LA.

To Millmen Cash buyers all kinds hard woods. We solicit correspondence. . . .

THE IMPERIAL LUMBER CO., LIMITED
SAW AND PLANING MILLS, WARREN, ONT.
RED AND WHITE PINE DEALS
All kinds of **SAWN LUMBER** By Carload or Cargo.
Registered Cable Address, "Pinewood." "American Lumberman" Telecode.
BRANCH OFFICE, MANCHESTER, ENG.
Head Office, TORONTO, CAN.

B. C. RED CEDAR SHINGLES
Several cars now in transit, hence can give prompt delivery.
SEND IN YOUR ORDERS
C. A. LARKIN - - Toronto

THE LONG LUMBER COMPANY

There is only one way to make and maintain a reputation for good goods—deliver the goods. It costs like smoke at times, but it pays in the long run, and we are glad we stuck to it.

HAMILTON SPECTATOR BUILDING ONTARIO

J. D. SINCLAIR
Vancouver Cedar Mills
VANCOUVER B.C.

FOR **High Grade Cedar**

Herman H. Hettler Lumber Company

Manufacturers and Wholesalers of . .

WHITE and NORWAY PINE LUMBER LATH and SHINGLES

Shipments by

—MIDLAND, ONT.

J. D. SHIER LUMBER CO., LIMITED
BRACEBRIDGE, ONT.
MANUFACTURERS OF **LUMBER, LATH AND SHINGLES**
Pine, Hardwood and Hemlock Floorings and Ceilings. Sash and Doors, Wood Turnings etc. All Dressed Lumber Kiln Dried if desired End Matched Flooring a Specialty.
GOOD PINE SIDINGS A SPECIALTY

Planing, Matching, Resawing, etc In Car Lots.
Manufacturer of **Doors, Sash, Mouldings, Ceilings**
End-Matched and Bored **HARDWOOD FLOORING** A SPECIALTY.
Lumber Kiln Dried in Any Quantity.
J. R. EATON - Orillia, Ont.
Correspondence Solicited. Phone No. 54.

THE CHARLEMAGNE & LAC OUAIREAU LUMBER CO., LIMITED,
404 Coristine Building, MONTREAL, P. Q.
Mills at Charlemagne and Montcalm on Great Northern Railway.

SAWN AND DRESSED **LUMBER**
Clapboards, Shingles, Laths, Butter Boxes
Write us for quotations. Shipments by rail or water.

CACHE BAY LUMBER INDUSTRIES.

Geo. Gordon & Co.,
Manufacturers of RED and WHITE PINE
Band - Gang Circular **LUMBER** AND LATH
CACHE BAY, Ont. C. P. R. 26 miles West North Bay

Cedar Cove Mill,
Vancouver, B.C.

E. H. HEAPS & CO.,

Ruskin Mill
Ruskin, B. C.

Vancouver, B. C.

Lumber, Lath, Shingles, Doors, Mouldings, Etc.

SPECIALTIES :

AA1 HIGH GRADE CEDAR SHINGLES.

Cedar Bevelled Siding, Cedar Door and Sash Stock, cut to size, Cedar Finish, Base, Casing, Newels
Balusters, etc. Douglas Fir Timber up to 85 feet in length.

W. J. SHEPPARD PRESIDENT
Waubesahe, Ont.

J. G. SCOTT, GENERAL MANAGER
Vancouver, B.C.

Pacific Coast Lumber Co.

LIMITED
VANCOUVER, B.C.
MANUFACTURERS OF

Fir, Cedar and Spruce Lumber, Lath, Mouldings, Turned Work, Etc. High Grade Red Cedar Shingles

Ontario Representative, W. J. LOVERING, - - - 112 Mail Building, TORONTO

D. C. CAMERON, President and Manager.

WM. ROBERTSON, Secretary.

J. E. YOUNG, Cashier

The Rat Portage Lumber Co., Ltd.

Manufacturers
of

White and Red Pine Lumber, Lath, Shingles, Sash, Doors, Turned and Band Saw Work

Dealers in CEDAR POSTS, POLES and TAMARAC PILING

Mills at RAT PORTAGE and RAINY RIVER, Ontario, WINNIPEG, Manitoba, and VANCOUVER, British Columbia. Head Office: RAT PORTAGE, Ontario
Our Vancouver Mill cuts High-Grade Cedar, Fir, Spruce and Red Cedar Shingles. Winnipeg Mills cut Pine, Tamarac and Spruce Lumber
We also Manufacture all kinds of Mouldings, Sash, Doors, Turned Work and Boxes. Correspondence solicited at all four points.

THOS. KIRKPATRICK,
MANUFACTURER OF

Red Cedar Shingles

Daily Capacity, 250,000 Mills at Hastings and New Westminster
Head Office: Hastings, B.C.

Orders Solicited and Correspondence Promptly Attended to. Telephone B 1425
Ontario Representative: W. J. SMITH, Fergus.

Export Lumber & Shingle Co.

Wholesale Dealers Limited

British Columbia Lumber and Shingles

The management of this company have had a lengthy experience in manufacturing and selling British Columbia Lumber and Shingles in Canada and the United States, and are well informed as to the requirements of the trade in those sections.

We are in a position to make prompt shipments at current market prices.

Correspondence and inquiries for prices and other information regarding British Columbia lumber conditions promptly answered.

YOUR TRADE RESPECTFULLY SOLICITED

Fee Block, 570 Granville Street, Rooms 3 and 4, Third Floor
Phone 2002

VANCOUVER - BRITISH COLUMBIA

COOKE & TAIT

MANUFACTURERS OF ALL KINDS OF

B. C. FIR AND CEDAR LUMBER AND SHINGLES

Saw Mill, Planing Mill and Shingle Mill: False Creek, Vancouver, B.C.

WRITE FOR PRICES.

Hazelmere Lumber Co.

HAZELMERE, B. C.

MANUFACTURERS OF

FIR, CEDAR and SPRUCE LUMBER

CLEAR CEDAR AND FLOORING

Our Specialty.

Long Distance Telephone.

W. C. WELLS

PALLISER, B. C.

Manufacturer of

High Grade Spruce, Fir, Cedar and Lumber of all Descriptions.

CORRESPONDENCE SOLICITED.

CANADIAN MANUFACTURERS and WHOLESALERS

THE PEMBROKE LUMBER CO.

PEMBROKE, ONT.

We make a specialty of Dimension Stock in Pine, Spruce and Hemlock, and solicit your enquiries.

DELAPLANTE - McBURNEY LUMBER CO.,

WHOLESALE

White Pine, Hemlock, Lath, Shingles

Stocks in Ontario at { Collingwood Midland Powassan Whitney Cartier Sturgeon Falls Callander North Bay

TORONTO OFFICE: Room 503 Manning Chambers.

Office, Yards and Docks, NORTH TONAWANDA, N. Y. Send us your enquiries

FOR Pine, Hemlock, or Hardwood, Lumber and Timber, Telegraph Poles, Ties, Posts, Lath, Shingles, Dressed Lumber, Sash, Doors, Interior Finish, End Matched and Bored Hardwood Flooring, etc., try

JOHN HARRISON & SONS COMPANY, LIMITED

We have a complete stock, two Saw Mills running in summer and one all winter.

HEAD OFFICE, SAW AND PLANING MILLS, OWEN SOUND, ONT.

RHODES, CURRY & CO., Limited

LUMBER MERCHANTS.

Yards at Amherst, Little Forks, Sydney and Halifax.

BUILDING MATERIAL of all kinds carried in stock. We are buyers of Ontario Basswood, Elm and Pine.

Amherst, N.S.

Sawn and Hewn Spruce, Hemlock, Pine and Birch Timber, Spruce and Pine Boards and Plank, Birch and Ash Boards and Plank, Flooring, Shingles, etc.

JAMES J. MURPHY, Bank of Hochelaga Building **QUEBEC**

The Cook & Bros. Lumber Co.

MANUFACTURERS OF

Of Ontario, Limited
MILLS at SPRAGGE, Algoma Dist., Ont.
on "Soo" Branch C.P.R.

OFFICES { Manning Arcade, Toronto
Coristine Building, Montreal
And at Mills at Spragge.

White and Red Pine Lumber and Lath

Water Shipments

THE M. BRENNEN & SONS MANUFACTURING CO., LIMITED

Saw Mills at RAINY LAKE, Ontario. Planing Mill and Head Office: HAMILTON, Ontario.

THE NIPISSING LUMBER COMPANY, LIMITED

Mills at CACHE BAY and SPANISH RIVER, Ontario.

Manufacturers of and Wholesale Dealers in all kinds of LUMBER AND LATH

Both Railway Delivery and Water Shipments. Correspondence Solicited. The NIPISSING LUMBER CO., Limited Head Office: HAMILTON, ONT.

AUGER & SON - Quebec PULP WOOD AND TIES

Bought at Any Station.

Also Dimension Timber, Sawn to Sizes, Telegraph Poles and Lumber.—Write Us.

A. F. BURY AUSTIN WHOLESALE LUMBER and TIMBER CANADA PINE

Bank of Ottawa Building, 224 St. James St., - MONTREAL, CANADA

SPECIALTIES: Railway Bridge Timber and all kinds of Hardwoods; Ship Decking, Norway and White Pine, Dimension Timber, Norway Car Sills, Car Flooring, Telegraph Poles, Railway Ties, Oak and Whitewood, Planed and Rough Lumber, British Columbia Pine, Southern Pine, &c.; Birch Flooring, hollow back, end butted.

Eastern Agent for The Pacific Coast Lumber Company, Limited, Vancouver, B. C.

Douglas Fir Timber in any size or length up to 90 feet long. Timber Planers face up to 24 inch x 30 inch. Dry Kilns of large capacity. Rough and Dressed Lumber, Douglas Fir and Cedar.

WRITE FOR PARTICULARS AND QUOTATIONS.

R. LAIDLAW LUMBER CO.

JAS. PLAYFAIR.

D. L. WHITE.

PLAYFAIR & WHITE

Manufacturers and Wholesale Dealers

LUMBER • LATH • SHINGLES

Contractors for Railway Supplies BILL TIMBER a Specialty MIDLAND, ONT

A. & P. WHITE

Manufacturers of and Dealers in

Sawn and Planed Lumber, Dimension Timber. Joisting Car Sills, Car Flooring, Shingles and Lath.

PEMBROKE ONT.

GET YOUR LUMBER AND TIMBER FROM

PINE LUMBER COMPANY,

(On C. P. R. Main line near Sudbury)

PINE, ONT.

F. MCGIBBON & SONS,

PENETANGUISHENE ONT.

Manufacturers of Pine, Hemlock and Hardwood Lumber, and dealers in Cordwood. Hemlock Bills cut on short notice.

MAITLAND, RIXON & CO.

OWEN SOUND, ONTARIO.

Manufacturers and Dealers

LUMBER LATH, TIES, POLES, SHINGLES, ETC.

Make a Specialty of Long Pine, Cedar and Hemlock Bill Stuff. We ship by C. P. R., G. T. R., and by Water.

Turner Lumber Co., Limited

MANUFACTURERS

LUMBER and LATH

Shipments by Rail or Water. • Midland, Ont.

HARDWOOD FLOORING

End Matched, Bored, Steel Polished, and Bundled

Send for Price List

A few cars of selected Maple and Birch and other Hardwoods at close price

THE SEAMAN KENT CO., Limited

160 Bay St. Toronto Factory, Meaford, Ont.

THE MENZ LUMBER COMPANY

Manufacturers and Wholesalers

BRITISH COLUMBIA FIR, SPRUCE AND

CEDAR LUMBER, RED CEDAR SHINGLES

We Solicit Your Inquiries. J. F. FOSS, Manager. 624-625 Union Bank, Winnipeg, Man.

CEDAR LUMBER AND POLES FOR SALE

I can saw out to your order, during the winter months, bills in heavy square Cedar, or Planks.

Have also for sale a few cars of Poles from 25 to 50 ft.

Correspondence Solicited.

J. S. FINDLAY,

OWEN SOUND, ONT.

NEW BRUNSWICK LETTER.

(Correspondence of the CANADA LUMBERMAN.)

ST. JOHN, N.B., April 28th, 1905.—The saw-mills in this vicinity have, with one or two exceptions, begun operations for the season during the past ten days. The logs now being sawn were in every case held in stock here during the winter. Few logs are being offered for sale as yet, it is rather early considering the late opening of the small rivers and brooks in the lower counties. Rafting operations have not yet been started at Fredericton and it will be some weeks yet before the local mills will receive any important quantity of the thirty millions of feet which lay in the river at that place and vicinity during the winter. These logs and most of those which were cut between here and Grand Falls during last winter can be depended upon to come along in due time, but beyond that the outlook is decidedly discouraging and is causing the local manufacturers considerable uneasiness. It is felt that at least a week of heavy rains is needed at the head-waters of the St. John before the river will be in a condition for driving purposes. When it is considered that the local mills depend almost entirely upon the sections beyond Grand Falls for their logs, it can be readily seen how vital the consequence of a general hang-up would be. Such an event would mean, taking into consideration the amount of logs available between here and Grand Falls, that the total output of sawn lumber for this season would be at least sixty per cent. below the average.

A feature of the markets during the past month has been the increasing demand for and the advance in prices of American spruce deals. While there is no important quantity available at this port at

this date, there will be during the next three months some considerable quantities manufactured, although the total cut in this line for the season will not be up to the average. For delivery during the next three months no lower quotation on American deals (f.o.b. schr. St. John) than the following could be obtained: 10's and 12's, \$17.50 to \$18.50; 9 inch, \$16.00 to \$16.50; narrows, \$13.50 to \$14.00.

Spruce laths have shown little variation during the past few weeks and are quoted f.o.b. St. John, \$2.50 for dutiable and \$2.75 for non-dutiable. Stocks are extremely light and it will be June 15th before any quantity of importance is ready to go forward.

Cedar shingles are steady at prices mentioned a month ago, viz., (non-dutiable, f.o.b. St. John): Extras, \$2.95; Clears, \$2.45; 2nd Clears, \$1.90; No. 1's, \$0.90.

The lower grades are somewhat slow in the United States, but the demand for the higher grades in that direction is brisk and growing and, combined with the indications for a heavy local consumption of the cheaper grades, promises a good year in this line.

Freight rates on deals to New York City are quoted at \$3 per M, but there is a probability that before the end of May they may be 25 cents lower.

H. D. WIGGIN BOSTON, MASS.
89 STATE ST.
will inspect at mill and PAY CASH for

LOG RUN

Elm, Ash, Bass and other Hardwood
CORRESPONDENCE SOLICITED.

YELLOW PINE

We are in position to give first class stock. Reasonable prices. Prompt shipments. Mills in Alabama, Mississippi and Arkansas.

MANN, WATSON & CO. Muskegon, Mich.



Chasing Themselves Round the Block

That's what the dealers were doing last winter in order to get our **SPRUCE LUMBER** and they got it too. They got all we had and asked for more, but **WE COULDN'T SELL OUR STOCK TWICE** so had to refuse orders.

EVERY DAY now our mill is turning out 150,000 FEET OF THE BEST **SPRUCE LUMBER** ever made. We are ready for your orders and you can send them along.

The Red Deer Lumber Company
WINNIPEG, MAN.

UNITED STATES MANUFACTURERS AND WHOLESALERS

YOU CAN REACH

THE BONSAK LUMBER CO.
WHOLESALE HARDWOODS

ST. LOUIS
BY RAIL, MAIL
WIRE OR 'PHONE

SAW AND PLANING MILL ANNUAL CAPACITY, 100,000,000 FEET.

THE DIXIE LUMBER CO.
WHOLESALE **YELLOW PINE** MANUFACTURERS
ST. LOUIS, MISSOURI.
Timbers, Rift Sawn Flooring and Finishing
Mills at LITTLE BAY, ARK., ALDEN BRIDGE, LA., ALLENTOWN, LA.

HAEBERLE LUMBER CO.
Wholesale and Retail Dealer in
YELLOW PINE and **OAK TIMBER**

Large stock of Timbers and Bill Stuff carried in stock.
All sizes and lengths for immediate delivery.
Telephone No. 10 - - Cedar Street, NIAGARA FALLS, N.Y.

THE ROBERT H. JENKS LUMBER CO.
CLEVELAND, OHIO
MANUFACTURERS AND WHOLESALERS OF
YELLOW PINE, POPLAR, HEMLOCK AND HARDWOODS
Yellow Pine Timbers a Specialty

McGLURE LUMBER CO.
Wholesale Dealers in . . .

Hardwood Lumber

Carry in Stock and Have for Sale

Indiana Lumber & Veneer Co.
INDIANAPOLIS, IND.

Sawed and Sliced Quartered
Oak a Specialty

Correspondence Solicited. ☞☞☞☞

Veneers

ASH, BASSWOOD, BEECH, BIRCH, BUTTERNUT, CHERRY, CHESTNUT, COTTONWOOD, CYPRESS, ELM, GUM, HICKORY, MAHOGANY, MAPLE, OAK, POPLAR, SYCAMORE, WALNUT, POLES (Oak, Hickory and Ash), RIMS and SPOKES (Oak and Hickory), OAK BENDING PLANK, OAK BILL STUFF, RAILWAY TIES.

Office and Yards: 520 to 530 Frank in St., DETROIT, MICH.
Correspondence Invited on All Hardwoods.

FRANK G. BURY **BURY & NOBLE** MASON A. NOBLE

WHOLESALE **LUMBER - DETROIT** MICHIGAN

Send us your inquiries for Southern Yellow Pine

CANADIAN LUMBER SHIPMENTS.

From St. John, N.B.: Steamer Bavarian, for Liverpool, 94 tons birch lumber, 877,168 ft. deals. Steamer Alcides, for Glasgow, 387,424 ft. deals, 17,000 ft. lumber 62 tons birch timber, 3,528 ft. birch plank, 2,632 ft. birch ends, 5,115 bds. and 41 bxs. shooks. Steamer Florence, for London, 148,448 ft. deals. Steamer Virginian, for Liverpool, 486,288 ft. deals, 36,428 ft. scantling, 60,973 ft. ends, 34,810 ft. boards. Schooner Harry Knowlton, for City Island, 184,519 ft. deals, 124,027 ft. scantling. Schooner

Jennie C., for Boston, 130,500 ft. boards. Schooner Hunter, for Bridgeport, 87,079 ft. deals, 31,874 ft. scantling, 112,720 ft. plank. Schooner Comrade, for Stonington, 105,615 ft. boards. Schooner Lena Maud, for Boston, 119,776 ft. boards. Schooner Valetta, for Boston, 69,592 ft. plank, 10,043 ft. scantling, 14,172 ft. boards, 41,804 ft. pine boards. Schooner Mineola, for City Island, 1,791,700 ft. laths. Schooner Rewa, for New Haven, 107,391 ft. plank, 75,551 ft. scantling, 4,095 ft. boards, 100,400 laths. Steamer Lake Erie, 11,446 pcs. basswood lumber

13,191 maple blocks, 61 pcs. rock elm lumber, 535 pcs. birch timber, 579 pcs. elm, 1,497 pcs. spruce deals, 1,619 doors, 227,436 ft. spruce deals, 38,303 ft. scantling, 4,920 ft. ends, 6,904 ft. birch plank, 95 ft. birch scantling, 365 ft. ends, 133 tons birch timber, 7,147 birch squares, 259 maple logs, 876 bds. elm lumber, 1,322 pcs. oak lumber, 2,535 bds. maple flooring, 1,921 doors, 1,202 pcs. chestnut lumber, 1,107 pcs. walnut lumber, 1,845 maple blocks. Steamer Manchester Commerce, for Manchester, 485,459 ft. spruce deals, 2,640 ft. spruce scantling, 2,359 ft. spruce ends, 52,789 ft. birch plank,

9,563 ft. birch ends, 8,333 ft. shooks. Steamer Manchester Importer, for Manchester, 748,412 ft. spruce deals, 6,430 bds. shooks, 192,493 ft. scantling, 37,493 ft. ends, 2,352 bds. pulp boards. Schooner Romeo, for Boston, 92,100 ft. plank, 63,874 ft. scantling.

Cable address: "Dundonian, Dundee."

BERG & SON,
Timber and Wood Pulp
Agents and Brokers
DUNDEE, SCOTLAND
Contracts made between Shippers and Importers
Correspondence solicited

BRITISH WOOD BROKERS AND IMPORTERS

FARNWORTH & JARDINE

Wood Brokers and Measurers

Cable Address "Farnworth," Liverpool. 2 Dale St., 71 Regent Road **BOOTLE LIVERPOOL, ENG.**

F. A. Lightbody & Co.

8 Gordon Street - GLASGOW, SCOTLAND

WOOD BROKERS

Cable Address: "TENEBRIS," GLASGOW. Codes: A. B. C., A 1, "Zebra" and Private.

Agents for **CANADIAN WHITE PINE AND SPRUCE; Hardwoods in Log, Etc.**
Shipments handled to the best advantage to all ports in the United Kingdom. Correspondence Solicited.

LOUIS BAMBERGER, 2 Broad Street Building, LONDON, E. C.

IMPORTER OF Pine, Spruce and all Canadian Wood Goods
Telegraphic Address "Bellywood, London."

Are Open to Contract for Glued-Up **BASSWOOD KEYB**

ZEBRA CODE A. B. C. CODE DIRECTORY CODE

GELLIBRAND, HEYWOOD & CO.

Wood Agents and Brokers

Cable Address: "GELLICHT," LONDON 57 Gracechurch St. London, E.C. England

SMITH & TYRER - 14 Tithebarn Street, LIVERPOOL
.. WOOD AGENTS ..

Cable Address—"Walmer," Liverpool.

Halifax, N.S., Office—SMITH, TYRER & Co., Metropole Bldg., Hollis St. Halifax, N.S

Edmiston & Mitchells
TIMBER BROKERS

Cable Address: "BDMISTON" Glasgow. 33 Renfield Street, GLASGOW

GANT & KEMP  **TIMBER BROKERS**

52 St. Enoch Square, GLASGOW

Cable Address: "TECTONA" Glasgow.
At and A B C Codes used.

Every lumberman wants it **35 cents buys it**
Scribner's Lumber and Log Book

BRIMFUL OF EVERY-DAY PRACTICAL INFORMATION
Address: THE CANADA LUMBERMAN, Toronto

CABLES, DOORCHECK LONDON

We are Buyers of Pine Doors and Mouldings, Electric Wire Casings, W.C. Seats, Wooden Mantel Pieces, Sashes and Frames, and all kinds of ready made joinery.

LONDON STORES: Locke's Wharf, Edmonton, N.

STAVERS & STAVERS

OFFICES: 158, Leadenhall Street, London, E.C.

Manufacturers and Importers of **JOINERY**

FELBER, JUCKER & CO.

Lumber Importers

MANCHESTER ENGLAND

Invite offers from Lumbermen for . . . Spruce Deals and Battens, Spruce and Pine Floorings, Shooks, Sashes, Mouldings, Dowels, Broom Handles, Chair Stock, Seats, etc., or any Woods Suitable for English Market.

Telegraphic Address: FELBER MANCHESTER.

ASHTON & PETFORD

BISHOP LANE, - HULL, ENGLAND

BUYERS OF BOX SHOOKS

Invite correspondence from manufacturers who are in a position to export to Great Britain.

Cable address, "Shooks," Hull. Codes—A. B. C. 4th Edition and Zebra.

JOSEPH OWEN & SONS, LTD.

Timber Importers

Cable Address "Owen Liverpool" Liverpool, Eng.

BUYERS OF

White Ash Logs and Planks.
Oak Logs and Planks.
Rock Maple Logs and Planks.
Rock Elm Logs.
Hickory Logs.

... ALSO ...

All classes of Lumber and Manufactured Wood Goods suitable for the English Market.

JAMES WEBSTER & BROTHER

BOOTLE, LIVERPOOL, ENGLAND

TIMBER MERCHANTS

BUYERS OF Oak, Birch, Ash, Grey Elm Logs and Lumber, Elm Staves and Heading, Handies of all descriptions
Veneers A Specialty

ALFRED DOBELL & COMPANY
WOOD AGENTS AND BROKERS

Liverpool and London Chambers - LIVERPOOL, ENGLAND

CABLE ADDRESS "DOBLE LIVERPOOL"

THOMPSON, BLOIS & KJELLGREN

ALL KINDS OF LUMBER AND LOGS

BRANCH OFFICES

41 Corporation St., MANCHESTER
Waterloo Chambers. GLASGOW

HEAD OFFICE

17 Gracechurch St., LONDON, E.C.

BRANCH OFFICE

Brook 1, HAMBURG

CASH ADVANCES MADE AGAINST SHIPPING DOCUMENTS

THE ONTARIO LUMBER CO. LIMITED

MILLS: North Bay, C.P.R. and G.T.R. Delivery.

WHITE PINE LUMBER, LATH AND SHINGLES.

35 and 36 Home Life Building TORONTO, Ont. MILLS: French River, Georgian Bay Water Shipment Only.

Is it your wish..

To Purchase or Sell as quickly as possible A PARTICULAR LOT OF LUMBER A MILL PROPERTY SECOND-HAND MACHINERY

An Advertisement in the 'Wanted' And 'For Sale' Department of the

CANADA LUMBERMAN WEEKLY EDITION

Will secure for you a Buyer or Seller, as the case may be. Address, The Canada Lumberman, Toronto

CANADIAN LUMBER WANTED

We solicit consignments of long and short lumber from the Maritime Provinces and are prepared to purchase White Pine and Hardwoods in Ontario and Quebec.

ADDRESS:

CHAS. S. WENTWORTH & CO. Room 510, 147 Milk St. BOSTON, MASS.

THE KING AND BARTLES LUMBER CO. PINE, POPLAR AND HARDWOODS

HEADQUARTERS: Citizens' Building, Cleveland, O. HARDWOOD Distributing Yard, McMinnville, Tenn. We buy and sell Pine in Car and Cargo Lots

McLennan Timber Land and Lumber Co., Limited

Selling Agency and Dealers in all kinds of Timber Lands. Offices: Quebec, 131 St. Peter St. Ottawa, Room 9, Central Chambers.

GEO. G. GLADMAN MANUFACTURER OF WHITE PINE AND HEMLOCK LUMBER LATH AND SHINGLES

Mills at Smith's Bay Township of Carling

PARRY SOUND, ONT.

CORRESPONDENCE SOLICITED

WE have Three Millions of Hemlock, running in lengths from 10 to 24 feet, which we are prepared to cut in blocks of 50,000 feet or over.

THE WOODSTOCK LUMBER & MANUFACTURING CO.

Dealers in Pine, Hemlock and Hardwood Lumber..

WOODSTOCK, ONTARIO

A. P. EBERT

MANUFACTURER OF AND DEALER IN

Pine and Hardwood Lumber, Lath, Shingles, Posts, Broom Handles, and Short Hardwood Dimension Stock

WIARTON, ONT.

THE NEW LINE

Through the Spruce Forests of the Laurentian Mountains—between Quebec and Hawkesbury.

WATER-POWERS, TIMBER LIMITS AND ELECTRIC POWER FOR SALE. IDEAL PULP-MILL SITES.

Unexcelled Export Facilities at Quebec.

A. J. GORRIE, General Supt.

MONTREAL

GUY TOMBS G. F. & P. A.



CURRENT LUMBER PRICES--WHOLESALE

TORONTO, ONT.

CAR OR CARGO LOTS.

Table listing lumber prices for various types like 1 inch No. 1 Pine, 1 1/2 inch No. 2 Pine, etc.

HARDWOODS—PER M. FEET CAR LOTS.

Table listing hardwood prices for Elm, rock, mill, Hickory, etc.

QUEBEC, QUE.

WHITE PINE—IN THE RAFT

Table listing white pine prices in the raft for square white pine, etc.

RED PINE—IN THE RAFT.

Table listing red pine prices in the raft for measured off, etc.

OAK—MICHIGAN AND OHIO.

Table listing oak prices for by the dram, etc.

ELM.

Table listing elm prices for by the dram, etc.

ASH.

Table listing ash prices for 10 inches and up, etc.

BIRCH.

Table listing birch prices for 14 inch, etc.

OTTAWA, ONT.

MANUFACTURERS' PRICES.

Table listing manufacturers' prices for pine, good sidings, etc.

Table listing lumber prices for Pine good strips, Pine good shorts, etc.

Table listing lumber prices for Pine shorts, Pine s. c. sidings, etc.

Table listing lumber prices for LATH, SHINGLES, Sawed Pine, etc.

BUFFALO AND TONAWANDA, N. Y.

WHITE PINE.

(Wholesale selling price.)

Table listing lumber prices for Buffalo and Tonawanda, N.Y. including Uppers, Shelving, etc.

The following quotations on hardwoods represent the jobber's buying price at Buffalo and Tonawanda:

Table listing hardwood prices for White Ash, Black and Brown Ash, Birch, Elm, Maple.

BOSTON, MASS.

Table listing lumber prices for Boston, Mass. including White Pine Uppers, Selects, etc.

NEW BRUNSWICK CEDAR SHINGLES.

Table listing prices for New Brunswick Cedar Shingles.

BRITISH COLUMBIA SHINGLES.

Table listing prices for British Columbia Shingles.

BAY CITY AND SAGINAW, MICH.

UPPER AND SELECTS.

Table listing lumber prices for Bay City and Saginaw, Mich. including Uppers, Selects, etc.

STRIPS, A AND B (CLEAR AND SELECTS).

Table listing strip prices for Bay City and Saginaw, Mich.

FINE COMMON OR C.

Table listing fine common or c prices for Bay City and Saginaw, Mich.

SELECTED NO. 1 SHELVING OR FENCING STRIPS.

Table listing selected no. 1 shelving or fencing strips prices.

BARN BOARDS OR STOCKS.

Table listing barn boards or stocks prices.

SHIPPING CULLS OR BOX.

Table listing shipping culls or box prices.

SHAKY CLEAR.

Table listing shaky clear prices.

SHINGLES, 18-IN.

Table listing shingles prices.

LATH.

Table listing lath prices.

ALBANY, N. Y.

Table listing lumber prices for Albany, N.Y. including Uppers, Box, etc.

WESTERN CANADA

Western Office of The Canada Lumberman,
720-721 Union Bank Building, WINNIPEG, MAN.

BANQUET OF BRITISH COLUMBIA LUMBERMEN.

The first annual banquet of the Vancouver members of the British Columbia Lumber and Shingle Manufacturers' Association was held in the Hotel Vancouver on the evening of March 30th last. The affair was attended by a representative gathering and good fellowship was in evidence on all sides. Those present included: Messrs. H. DePencier, Richard H. Alexander, A. C. Flumerfelt, S. N. Jarret, E. C. Mahoney, E. R. Vigor, W. B. Cooke, T. F. Paterson, H. Cotton, Thomas Kirpatrick, R. McNair, William Abil, W. Allen, J. B. Tiffin, William E. Lackery, James A. McNair, C. M. Beecher, L. A. Lewis, P. Spicer, J. F. Boyd, J. F. McRae, J. W. Hackett, D. Robertson, Joseph Chew, C. Chisholm, H. H. Spicer, G. F. Gibson, J. D. Moody, P. I. Palmer, C. H. Mortimer, Thomas E. Atkins, William Tytler, J. G. Scott, Henry Eckert, J. Hadden, J. G. Woods, F. W. Peters.

A letter of regret was read from Mr. F. W. Jones, of the Columbia River Lumber Company, Golden, who is president of the Mountain Lumber Manufacturers' Association and who recently interviewed the Dominion Government on behalf of an import duty on lumber.

In the absence of Mr. John Hendry, president, Mr. H. DePencier occupied the chair. Mr. C. M. Beecher was vice-chairman.

After the menu had received due attention Mr. DePencier opened the toast list with "The King," which was heartily drunk while the orchestra played the National Anthem. Coupled with the toast of "The British Columbia Lumber and Shingle Manufacturers' Association" were the names of Mr. C. M. Beecher, Mr. J. G. Scott and Mr. L. A. Lewis, representing the lumber branch of the Association, and Mr. James McNair, Mr. William Tytler and Mr. C. A. Flumerfelt, representing the shingle branch.

Mr. Beecher referred to the sad and downcast look which most of those engaged in the lumbering industry had worn for some time, but he was glad to see a change of expression on their faces to-night and hoped that it presaged the return of better times for the industry. Mr. J. G. Scott also hoped for the early return of prosperity and touched appropriately upon the work and interests of the Association. In a short speech Mr. Lewis reviewed the conditions of the lumber industry. He maintained that if the Dominion Government imposed the duty which had been asked for, the lumber and shingle industry would soon enter a new period of prosperity.

For the shingle trade, Mr. James McNair counted the ups and downs of the shingle industry and predicted that there would be a strong fight to hold the Canadian market during the coming season. He urged the British

Columbia members to stand together for their own interests as well as the benefit of the industry. Mr. Flumerfelt gave a very humorous address. "Who are those talking of losses," he asked. "Why," he continued, "I see by returns published in the papers that the industry has paid the Provincial Government \$400,000. Besides that it has paid taxes, and last but not least has paid freight rates to the Canadian Pacific Railway." Speaking seriously, he dwelt upon the magnificent resources of the province of British Columbia and of the great future before her. What was wanted was an interchange of confidence and this would bring prosperity.

Mr. E. H. Heaps was then called on to speak of the general work of the Association. Notwithstanding the difficulties which had been encountered, he said the Association was stronger and in better shape than at any other time in its history. It had been beneficial to the lumber industry, and if the lumbermen stood together good results would follow.

Mr. J. G. Scott, in a neat speech, then proposed the toast of "Canada's National Highway", to which Mr. F. W. Peters was called upon to respond. Mr. Peters said he was strongly impressed with the remarks he had heard. After some humorous reference to difficulties which arisen he said that in all trades conditions causing differences would arise; but conditions change constantly. He thought the gentlemen on the coast engaged in the lumber industry did not fully grasp the whole situation as from the point of view of the railway company. He assured his hearers that the Canadian Pacific was not antagonistic to the lumber manufacturers of British Columbia, but on the contrary was in heartiest sympathy with all. The railway company favored a duty on lumber, but situated as it was it was impossible to act. The settlers in the new provinces in the middle west were in large measure from the United States and they naturally patronized the millmen of their own country. There was no denying that the American millmen used Canada as a dumping ground for their surplus and that the dumping clause was ineffective and inoperative. If a duty of only 5 or 10 cents a thousand were imposed this protective clause could be exercised.

The object of the company was to develop Canadian industries and if confidence were maintained between the manufacturers and the railways the latter would be found working to the mutual advantage of both. During the past year 6,500 empty cars had been hauled from the Territories to the Pacific coast for the lumber trade; had these been loaded the company could have afforded to give a lower rate on freight eastbound. The rate could not be reduced below a certain limit and fir lumber was

the limit. Everything was done to increase the westbound freight traffic and when loads could be given for cars coming west the company would be in better position in regard to eastbound traffic. The development of trade in the Orient might tend to this and the company would not relax any effort. Concluding a very important and interesting address Mr. Peters warmly thanked the lumber manufacturers for the privilege of being present at their most interesting social gathering.

Mr. D. Robertson and Mr. James Hackett, of the firm of Robertson & Hackett, and Mr. P. I. Palmer, of the Vancouver Sash & Door Company, responded briefly on behalf of the factory branch of the Association.

The toast of "The Loggers' Association" brought an eloquent reply from Mr. T. F. Paterson, who said he did not think the people realized the full importance of this part of the industry. In one year \$2,000,000 were paid out as wages, and every dollar was spent in the coast cities and was building up the province in a way not realized. Referring to the C. P. R. he said that in the interview with the Government at Ottawa the delegation had had the active sympathy of that railway company. Sir Thomas Shaughnessy told some of the members of the delegation, who had been sent to Montreal to see him, that they could use the name of the C. P. R. to say that it was in favor of the duty, and if it were granted, he gave his word that the freight rates would not be raised. Mr. Paterson was optimistic regarding the future of the industry.

He said it had been stated that British Columbia members at Ottawa were not strong in support of a duty. He would give a firm contradiction to this, as all the seven, with Senator Templeman at their head, were putting up a sturdy fight with this object in view. Mr. Paterson was sure some measure of protection would be given this session to the lumber industry. The majority of the members of the House of Commons were at the back of the lumbermen; Sir Wilfrid was in favor, and while Hon. Mr. Fielding was not outspoken, he fully realized the handicap the lumbering industry labored under. It was to the interest of the C. P. R. and the lumbermen to work together, and he thought the railway company would do all it could for the trade in this province.

THE "CANADA LUMBERMAN" was then toasted and responded to by Mr. C. H. Mortimer, while Mr. Vigor, of the Lumberman and Contractor, replied to the toast to that journal.

Mr. Richard Alexander responded to the toast of the "Vancouver Board of Trade." He spoke in eulogistic terms of the work done by the Board's delegates in connection with the movement for an import duty on lumber. Mr. R. P. McLennan entered at this juncture

and also responded. Toasts to the "Local Press," "The Ladies" and "The Chairman," concluded the evening's programme.

E. H. HEAPS & COMPANY, VANCOUVER, B. C.

This company are making a number of changes and improvements at their mills. They are installing a box-making plant and also a Mershon band re-saw and a "Hog" for chewing up refuse for fuel. Several old dry kilns which, on account of their close proximity to the mill, were causing an excessive charge for insurance on the whole property, are being torn down and three new kilns are to be built as an extension to the new ones recently put up. The wood-working plant is also being rearranged and placed to better advantage and new machinery added. Electric motors are being installed to supplement the steam plant, which has become insufficient. The company, in common with other manufacturers in British Columbia, regret the large amount of waste material for which there is at present no market. This want of a market renders useless the practising of the finer economies to which so much attention is now given in Eastern mills. The situation in this respect, however, is every year improving as the population of the province increases and the towns and cities are being built up.

ADAPTABILITY OF DOUGLAS FIR FOR STRUCTURAL PURPOSES.

The British Columbia Mills, Timber and Trading Company, Vancouver, B. C., have sent us a copy of an address delivered by Mr. G. H. Gilman, St. Paul, Minn., master car builder of the Northern Pacific Railroad, before the Northwest Railway Club at St. Paul. Mr. Gilman has had a wide experience in building cars of fir, and before going to St. Paul spent some years in charge of car building at the Northern Pacific shops at Tacoma. The address follows:

Mr. President and Gentlemen:—I have the pleasure of presenting this paper on what is known as Washington and Oregon fir. I can freely say that we have demonstrated the value of same beyond a doubt. It is no longer a question of its superiority to eastern and southern pine. It is noted for its length, strength and durability, and its weight is only about 75 per cent. of that of its nearest competitor, Georgia pine. This alone is an important matter to consider in freight car construction, to say nothing of handling and transportation. However, fir, like all other lumber, must be properly prepared, graded and manufactured for the purpose for which it is intended. The tendency has been to buy the cheapest stock that could be found, but it is very doubtful economy. During my railroad experience I have made several tests, and found it equally as strong as oak in many respects. I would not recommend it for end sills, draft timbers, truck and body bolsters, but for longitudinal sills, plates, posts, braces, girths, siding, roofing, lining and decking it is the best in the world and has no equal.

There are different kinds of fir, the red and

yellow, the fine and the coarse grain. The fine grain is grown in uplands, while the coarse is grown in valleys and will shrink a great deal more than the fine grain on account of the pith, but after it is properly seasoned it is equally as strong on account of its heavy fibre. Fine grain fir is preferable for siding on account of the fibre. The subject of flat and bastard grain has often been brought up for siding and roofing. I would not recommend it for cabooses or refrigerator cars, but for the ordinary freight car it is just as good, and for roofing, I think, better, as it is not so apt to split. One great trouble with mill men in this section of the country is that they pay no attention to the graining of the siding, which adds to the appearance when applied to cars.

We have all classes of cars built of fir. In 1893 we built 200 Street's stable cars at the coast. I might say along about that time fir was being tested to its full extent, and, in fact, had but few friends, especially in the east. I consider a car built on this line the most trying on wood of any kind. However, they are holding their own with others built of oak, Georgia and Norway pine. Had we known how to handle fir the same as we do now they would be far superior.

Fir, to be treated properly for car construction, should be cut from six months to a year, as was our custom at the coast, in order to weather dry. We usually carried a year's stock on hand of sills, decking, roofing, and siding. We would manufacture as much during the summer months of the above as we could care for, to prevent putting it through the kiln we would raise the temperature to 160 degrees gradually, when necessary to use the kiln, in about ten days.

I personally prefer weather dried fir to kiln dried, and would not recommend drying lumber over 2½ inches in a kiln, on account of its checking.

Spruce lumber should be handled practically the same way. For lining the inside of refrigerator cars it is equally as good as basswood for holding its place, and will last longer when it comes in contact with moisture.

Mr. Bihler, consulting engineer, Tacoma, Wash., examined timbers in Columbia River bridge at Pasco after sixteen years' service, and found them sound. These timbers were under water for perhaps eight months in a year, and exposed for the balance of the time. Where the period of exposure to the air is longer, and immersion correspondingly less, the timber would have less ultimate life.

J. H. Cole, superintendent of the Keokuk and Hamilton Bridge Company, in 1891 purchased timber from the St. Paul and Tacoma Lumber Company for a bridge spanning the Mississippi River at Keokuk, Ia. Frank B. Cole, his brother, and editor of the West Coast Lumberman, visited him some three months ago, and in conversation with his brother he said, as far as he could ascertain, the timbers are in as good shape as they were when put in. Previous to the advent of fir, white pine stringers had been in use. Ever since the bridge was built it has been necessary to renew them every seven years.

As to the strength of fir: In 1896 I personally made the following tests:

(1) With ten pieces of green fir and green oak a lift was made until piece broke. A dressed piece 2 in. square was given an 18 in. span, and lift was made by a hydraulic jack, with the following results:

FIR, GREEN.	OAK, GREEN.
2,950	3,250
3,100	2,100
3,050	2,600
3,000	3,000
2,750	3,000
2,825	2,800
2,325	3,600
2,800	2,200
2,450	3,000
3,200	1,800
28,450	27,350
Average 2,845	Average 2,735

One hundred and ten pounds in favor of fir.

(2) Ten pieces were selected, both oak and fir, well seasoned and no attention given whatever to the bearing in regard to the grain. The lift was made until the piece broke. The result was as follows:

FIR SEASONED		OAK SEASONED	
Deflection	Strain	Deflection	Strain
5-16 inches	3,500	1-2 inches	4,250
5-16 inches	3,400	1-2 inches	3,300
7-16 inches	4,000	3-8 inches	2,300
3-16 inches	3,700	5-8 inches	3,900
1-2 inches	5,000	7-16 inches	2,300
7-16 inches	3,900	11-16 inches	3,100
7-16 inches	4,100	5-8 inches	3,100
1-2 inches	4,700	11-16 inches	4,200
5-16 inches	3,200	3-4 inches	3,000
5-16 inches	3,500	11-16 inches	2,700
60-16 inches	39,000	94-16 inches	32,150
Av. ¾ inches	3,900	5-8 inches	3,215

Six hundred and eighty-five pounds per stick in favor of fir.

(3) Six pieces of fir were selected, which had been under cover one year, with the following results:

FIR DEFLECTION	FIR STRAIN
9-16	4,300
3-8	4,400
7-16	4,400
7-16	4,100
1-2	4,300
1-2	4,400
Average 4,233 pounds.	25,400

In conclusion I wish to add that fir lumber is used for more purposes than any other lumber in the world; for house building it can be used in every detail.

BRUNETTE SAW MILLS.

The Brunette Saw Mills Company, of New Westminster, B. C., in addition to their well equipped saw and planing mill, have recently erected an additional building in which they have installed an up-to-date box-making plant, including, it is believed, the only dove-tailing and nailing machines in Western Canada. The Company manufacture annually about 400,000 salmon boxes. These boxes are made of fir with the exception of the ends, which are of spruce. These spruce ends are used to insure more secure nailing together. The Company also manufacture large quantities of butter boxes, which are made entirely of spruce and lined with paraffine to prevent the contents from

being tainted. These boxes are shipped to Manitoba and the Territories, and many of them return to British Columbia again filled with dairy butter. Quite a business is also done in the manufacture of strawberry and raspberry boxes, these being supplied to the fruit growers in the immediate locality and the Okanagan Valley and other fruit growing sections of the province. British Columbia produces strawberries in great abundance and of wonderful size and quality, and fruit growing generally is rapidly becoming an important and profitable industry.

WESTERN NEWS.

LaLonde, Milord & Co., planing mill owners, Winnipeg, Man., have dissolved.

Middeditch, Henderson & Wilson are opening a planing mill at High River, N.W.T.

Bawtinheimer & Sons, of Red Deer, N.W.T., are increasing their saw mill plant this spring.

C. H. Williams is building a saw mill at Otter, midway between Westminster and Abbotsford, B.C.

Woodley & Sharpe have purchased the lumber business and property of C. W. Milestone at Moose Jaw, N.W.T.

The Big Bend Lumber Company, of Arrowhead, B.C., have given notice of their intention to improve Fosthall creek for logging purposes.

Joseph Genelle, who has been operating a saw mill for several years at Cascade, B.C., is arranging to install a double cutting band mill.

The Red Cedar Lumber Co., of Vancouver, recently cut a shingle which measured 19 inches in width and was without a flaw. This is believed to establish a record.

The Sparwood Lumber Company, Limited, has recently been incorporated by the British Columbia Government, with a capital of \$35,000, to acquire and extend the saw mill business heretofore carried on at Sparwood, B.C., by Walter Wardrop.

Alex. Black, of Winnipeg, has been in British Columbia recently in connection with his timber properties. Mr. Black some time ago purchased the property of the McRae Lumber Company at Hosmer, B.C., and will probably form a company to operate it.

The Melita Lumber & Manufacturing Company is being formed at Melita, Man., with a capital stock of \$50,000, to take over the planing mill of Moorby, Badgely & Ward, and the lumber yard of Gaudin, DeWit & Company, amalgamating the two concerns.

The W. F. Hunting Lumber Company, of Vancouver, B.C., have made application to the Commissioner of Lands and Works for a twenty-one years' lease for lumbering purposes of lands situated on the east side of Boughey Bay, Havana channel, Coast district.

J. P. McGoldrick, president of the Royal Lumber Company, Nelson, B.C., closed a deal recently to purchase the properties of the A. M. Fox Lumber Company, of Spokane, Wash., for \$450,000. Mr. McGoldrick will move to Spokane and manage the property.

The Kawatsie Lumber Manufacturing Company, of which A. C. Fraser, of Vancouver, B.C., is the promoter and manager, will build a saw mill at Kawatie Bay, about 180 miles from Vancouver. The mill will have a capacity of about 12,000 feet per day, and will cut cedar almost exclusively.

Incorporation has been granted to the Export Lumber Company, Limited, of Vancouver, B.C., with a capital of \$100,000, to carry on the lumber business in all its branches. Another company recently incorporated in British Columbia is the Wilmot Lumber Company, Limited, which will have a capitalization of \$200,000.

The Moore & Whittington Lumber Company have recently commenced business at Victoria, B.C., and will manufacture and deal in rough and dressed lumber, mouldings, shingles, etc. Their mills are situated on Pleasant street. Mr. Moore will have charge of the mill, while Mr. Whittington will look after the Yates street business.

H. P. Gilmour, who recently returned to Vancouver from a trip to the Okanagan country, states that two new saw mills are about to be built in the district, each to have a capacity of 20,000 feet per day. One will be built by S. C. Smith and the other by Richardson & Greenhow.

The Telford Lumber Company, of Prince Albert, N.W.T., have suffered a heavy loss through the burning of their mill, valued at \$80,000, with insurance of only \$20,000. Their drive of logs, amounting to two hundred thousand peices, will have to be held over in Sturgeon Lake and the Red River for another season.

The Bowman Lumber Company have acquired the property and business of the Empire Lumber Company

at Revelstoke, B.C. The officers of the new company are: President and managing-director, S. H. Bowman; vice-president, E. C. Warner; secretary-treasurer, F. E. Sine. Their product will consist of lumber, lath, mouldings, and shingles and they will operate mills at Revelstoke and Comaplix, B.C.

The Hanbury Manufacturing Company have commenced work on their planing mill and dry kiln to be built at Elko, B. C. The plant will be equipped with modern machinery for dressing the product of the smaller mills in the district, which will enable the owners to market their product without incurring heavy freight charges. It is probable that Mr. Hanbury will build a sash and door factory at Elko in the near future.

The new mill of the Elk Lumber & Manufacturing Company, Fernie, B. C., will be completed this month. It is a modern mill with a capacity of 100,000 feet of lumber in ten hours. The supply of logs will be obtained from the Hosmer district during the open months when they can be floated down the river, while in the winter they will be furnished by a camp near Fernie.

F. M. Davis, of Edmonton, N. W. T., has effected the organization of the Edmonton Lumber Company, which will absorb his wholesale and retail lumber business. The capital stock of the company is \$50,000, and the officers are: President, James Carruthers, Montreal; vice-president, George Carruthers, Winnipeg; secretary-treasurer and manager, F. M. Davis. It is probable that later on the company will engage in the manufacture of lumber.

Chu Lai, manager of the Wang Yip Timber Company, of China, was in Victoria and Vancouver, B.C., the past month buying machinery for a large saw and planing mill to be built in China. Chu Lai worked for ten years in one of the British Columbia mills and thoroughly understands the lumber business. The machinery is being supplied by the William Hamilton Manufacturing Company, of Peterboro, while the Taylor Mill Company, of Victoria, are supplying 240,000 feet of lumber for the construction of the mill.

The Shannon Lumber Company, of Prince Albert, N.W.T., have been absorbed by the new Sturgeon Lake Lumber Company, Limited, with Arthur F. Bell as president and general manager. The capital of the company is a quarter of a million dollars divided into 2500 shares of \$100 each. The water in the Saskatchewan rivers is very low and much difficulty is being experienced by the lumbermen engaged in log driving on the Shell, Sturgeon and Red Rivers. The outlook for the wholesale and retail lumber trade is considered good. Prince Albert and the towns to the south are experiencing quite a building boom.

NEW and Re-laying from 12 to 60 lbs. per yard with fastenings; for Lumbering, Mining and Contracting Work. Immediate shipment from Stock. Get our prices before purchasing.

SESSENWEIN BROS.,
101 Shannon Street, Montreal.

RAILS and TRACK SUPPLIES

LUMBERMAN'S HORSE COLLARS

If You Are Looking for a Good Serviceable Collar Write to

THE R. M. BEAL LEATHER COMPANY - Lindsay, Ont.

Tanners of the Celebrated ENGLISH OAK HARNESS



The Hanchett Adjustable Saw Swage

For Log, Shingle, Small Circulars, Band, Band Resaw and Gang Saws

LET US SEND YOU A SAW SWAGE

We will send you a swage for you to use for 30 days, then if you feel that you can afford to do without it you are to return it at our expense. A TRIAL WILL COST YOU NOTHING.

Will make your saws run better, cut more lumber and save your saws. Construction simple. Workmanship the best.

Write for circular "F"

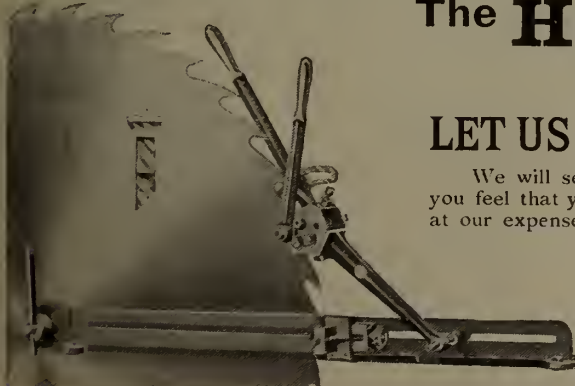

Hanchett Circular Saw Swage

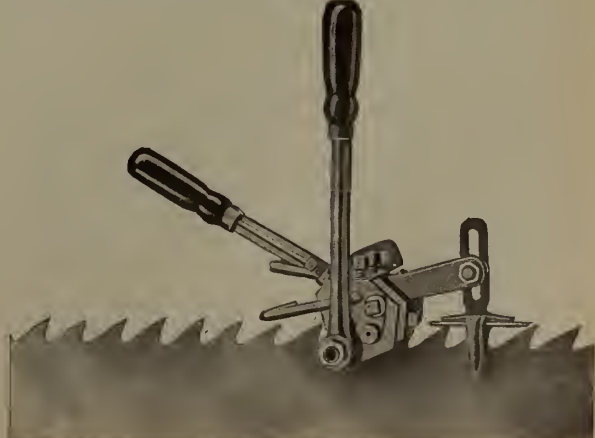

Hanchett Band Saw Swage

HANCHETT SWAGE WORKS,

Big Rapids,

Mich., U. S. A.

"Hanchett Swages do Good Work"

THE Wood-Worker and Retailer

CUTTING SLACK COOPERAGE STOCK.

A statistical statement declares that 97 per cent. of business enterprises result in failure. If that is true, why is it true? In stave factory practice it need not be true. In fact, all the lines of cooper stock production, including staves, heading and hoops, promise satisfactory returns, and redeem the promise when caution and industry prevail—not caution to secure labor at starvation prices, but caution against the display of ignorance in the selection of men and material. Get the best material to be had, and get the most out of it by selecting the best operatives obtainable and keeping the best of them as long as possible. If a man does not know the business well enough to see when one or more of his men are taking advantage of his ignorance of details, he should hire a foreman who does know, and let that foreman manage the minor details, not have the foreman report the man's faults, and then go and ask the man if the foreman told the truth. No wonder such tactics result in failure.

Taking into consideration the cost of raw material and the legitimate cost of manufacturing it into finished stock, it seems that loss is impossible. However, it requires but very

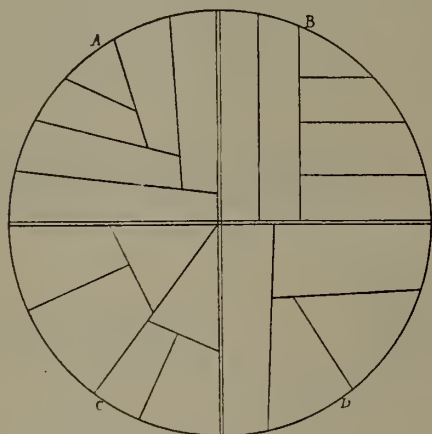

FIG. 1.

little ignorance, accompanied, as usual, with bad management, to secure those disastrous results that creep up so quietly that they are not noticed until their grip is so tight that release is impossible.

The cost of stave bolts is \$2 to \$5 a cord, each cord of the \$2 wood making 900 to 1,000, mostly cull staves, and promising but a small profit at the very best. But the \$5 wood is where the profit is. A cord makes nearly twice as many, mostly good staves, that cost the same to manufacture as the culls, yet if culls are in demand it pays to make them, and then it accommodates the people at both ends;

those who furnish the raw material want to dispose of their inferior stuff, and the buyers of cull staves want their demands supplied. Each cord, or part of a cord, must be closely inspected to see that it is full measure and of sufficiently good quality to be worth \$5 a cord, or \$2 a cord, or whatever price is being paid. Just here ignorance can waste money without knowing it. A man buying, inspecting and receiving timber should know a windshaken or a knotty stick, and what effect these defects will have on the stock to be made of it. He should know when the bolts or heading blocks are not too short. He should know and remember that stave bolts must be split right.

Of course, we are now considering slack cooperage, remembering that the grain of the wood must be consulted in order to cut staves correctly. This brings us to the proposition that the stave bolts must be properly prepared, otherwise they must be trimmed more to work with the grain. The extra trimming, in consequence of bolts having been improperly prepared, is expensive, because it consumes time that might have been consumed on good staves if the bolts had been right; and the trimming also cuts away a large amount of valuable timber, or timber that would have been valuable if it had been handled right.

Fig. 1 shows a log of stave timber with one quarter, marked *A*, split correctly, and three quarters, marked *B*, *C* and *D*, all split wrong, and these wrong ways are being extensively practiced. When a saw mill or a bolting saw does the work it is like the quarter shown at *B*, while *C* and *D* show styles of maul and wedge work done in the forest where the tree fell. Fig. 2 shows a stave bolt split like the quarter marked *A* in Fig. 1. This figure shows a few staves just cut from the bolt, the grain, which is seen to stretch from bark to heart, having been consulted—which means that the knife must start into the wood nearer the bark than it comes out, thus crossing the grain properly and making the smoothest staves, if the wood is well and properly steamed. If the grain of the wood is not consulted, the staves will be rough and of uneven thickness. Unless cut with the grain, staves will not hold their concave-convex shape while drying, which is important.

When a stave which has been worked into a barrel afterwards loses its concave shape and becomes convex towards the inside of the barrel, it has surely not been cut with the grain. This item of loss is greatest on staves that change their shape before they are made into the barrel, and are unfit for the poorest

quality of culls. All woods, except cypress, that grow in the middle states of the Mississippi valley have the grain stretched from bark to heart. All woods do not show the grain on the stick like oak, but the stave-cutter must know and consider the grain as if he could see it, when he is cutting staves from cottonwood and other woods that do not show it. Some men think these woods can be cut any way, but it is shown by long experience that they do not hold their shape and do not cut smooth. A



FIG. 2.

stave-cutter that insists that the grain of cottonwood need not be consulted makes many more defective staves.

In the matter of heading and hoops the grain need not be consulted, but ignorance is not to be tolerated if it can be avoided, because it can reduce the bank account in these lines in so many ways that to discuss them here would be tedious. Engineers whose duties bring them to see the cull heading, staves and hoops that come to the fire room to be burned, instead of being sold as good stock, can see where much of the money is being wasted, and can often discover the "short circuit in the office" before the fuse is blown.—"H. A. R.," in *The Wood-Worker*.

THE C. P. R. PLANING MILL, MONTREAL.

The Angus shops of the C.P.R. in Montreal occupy a rectangular space about 4,700 feet long and 2,000 feet wide. The buildings are arranged on each side of a passage, along which runs a 100 ton crane, enabling material to be easily transported from one shop to another. The planing mill, which is one of the most modern woodworking establishments on the Continent, is set back at some distance from the passageway. It is 126x500 feet, built of brick on concrete foundations, with a wooden roof truss. A row of built-up steel columns support the truss along the centre and divide the building into two bays.

All the lumber going into the make-up of the cars, with the exception of the hardwood used in finishing, is dressed. From the sills, which are 5 in. by 8 in. by 72 ft., and the truss plank 3 in. by 10 in. by 72 ft., down to the window battens and stops, 3-16 by 1/2 in., the

FOR THE CAMP

We have a very suitable lot of goods for camp supplies. We make this kind of trade a specialty. You who are not getting suited just as well as you would like, try us for your next order, and give us a chance to demonstrate our ability to give you satisfaction in this very important department of your business.

H. P. ECKARDT & CO.

Wholesale Grocers

TORONTO

material leaves the planing mill ready to take its place in the general construction.

Group and individual motor driving is used throughout the planing mill; for most of the machines individual motors are employed, and group driving for some of the smaller machines. The combined horse-power of the alternating current motors in the planing mill is 1,750.

The machines for the heavier woodwork are located along the west longitudinal track, where the work can be easily transferred to push cars and taken to the freight-cars erecting shop directly opposite the mid-way. A list of the machines is given here, together with the horse-power rating of the motor driving the individual or the group:

No. 8 Berlin planer and sizer, 50 h.p.; No. 3 Greenlee rip saw, 20 h.p.; No. 6 Fay outside moulder, 30 h.p.; No. 8 Berlin planer and sizer, 50 h.p.; group No. 174, 10 h.p., band-saw filer, Fay auto knife grinder, Perth knife grinder, emery wheel, circular saw sharpener; No. 3 Greenlee rip saw, 20 h.p.; No. 3 Greenlee rip saw, 20 h.p.; No. 24 Berlin planer and matcher, 30 h.p.; buzz planer, 5 h.p.; Fay 4-head dimension planer, 40 h.p.; four-head matcher and planer, 20 h.p.; No. 6 Greenlee cutoff saw, 15 h.p.; Bertram large rip saw, 15 h.p.; Bertram large butting saw, 15 h.p.; Bertram horizontal gainer, 20 h.p.; group No. 186, 15 h.p., No. 2 Greenlee auto cutoff saw, No. 5 Greenlee auto cutoff saw; No. 14 Greenlee mortiser, 15 h.p.; No. 5 Greenlee auto cutoff saw, 15 h.p.; Greenlee heavy car-boring machine, 20 h.p.; No. 3 Fay ripping saw, 20 h.p.; group No. 188A, 15 h.p., Bertram horizontal gainer, Greenlee 3-spindle boring machine; No. 2 Fay ripping saw, 15 h.p.; group No. 190, 20 h.p., Greenlee 5-spindle boring machine, Greenlee 3-spindle boring machine; group No. 191, 15 h.p., three-spindle boring machine, swing cutoff saw, Greenlee sill mortiser; vertical end tenoning machine, 30 h.p.; mortiser and boring machine, 15 h.p.; No. 6 Fay mortiser and borer, 10 h.p.; No. 14 Greenlee mortiser, 15 h.p.; No. 3 Greenlee gainer, 15 h.p.; group No. 196, 20 h.p., Greenlee boring machine, 40-ft. table, swing cutoff saw; group No. 197, 20 h.p., Greenlee boring machine, 40-ft. table, swing cutoff saw; No. 3 Greenlee gainer, 40-ft. table, 15 h.p.; No. 4 Greenlee tenoner, 15 h.p.; group No. 200, 20 h.p., No. 14 Greenlee mortiser, 40-ft. table, No. 58 Fay band saw; group No. 201, 20 h.p.,

Fay band saw, boring machine, Bertram gainer; group No. 202, 40 h.p., two No. 5 Greenlee horizontal can tenoners, two Bertram horizontal tenoners; group No. 203, 40 h.p., Fay 3-spindle boring machine, rip saw, Fay vertical gainer; group No. 204, 15 h.p., Greenlee 3-spindle boring machine, gainer; group No. 205, 20 h.p., double-headed shaper, hollow chisel mortiser; four-headed sticker, 20 h.p.; group No. 207, 15 h.p., No. 3 Greenlee cutoff saws and gainer, shaping machine; group No. 208, 10 h.p., double-headed shaper, 3-spindle boring machine; group No. 209, 10 h.p., horizontal tenoning machine, band saw; moulding machine, 10 h.p.; group No. 211, 30 h.p., swing cutoff saw, circular saw, buzz planer, rip saw; group No. 212, 20 h.p., vertical sill tenoning machine, Greenlee car boring machine; band re-saw, 15 h.p.; group No. 214, 15 h.p., cutoff saw, band saw, dimension saw.

This incomplete list will give some idea of the amount of machinery in operation, which when worked to its full capacity is capable of preparing the woodwork for twenty-five cars a day.

Situated at the western end of the mill is a gallery for grinding the machine knives and saws. Some of these are of peculiar interest, being entirely automatic. Included in the list of machines here are 2 saw filers, two emery wheels, 1 surface grinder, 2 automatic band saw files, automatic knife grinders and automatic circular saw grinders. In these latter machines a circular saw may be placed and each tooth finished in turn with an accuracy impossible by hand labor.

One of the most important features in connection with the planing mill is the system of collecting saw dust, shavings and trimmings from the different machines and conveying them to bins on the roof of the building and eventually to the boilers in the power house. This system was installed by C. H. Gifford & Company, managers of the Philadelphia house, B. F. Sturtevant Company, and is undoubtedly the largest dust-collecting system on this continent.

THE RETAILER VS. THE LUMBER TARIFF.

What the retailer wants is low-priced lumber, and for the best interest of his business those prices should be steady. There is nothing that scares a prosperous builder more than to hear that there is a half dollar raise on lumber, and

this might be the case when the half dollar might not make a difference of \$25 on the house that man was going to build.

If the retail dealers of the country understood the tariff question, they would vote to a man to take the duty off Canadian lumber.

In fact, I think they would be more anxious to take off that duty than the Canadians themselves.

In reality, the Canadian has lost very little by the duty that the United States has imposed on dressed and rough lumber. The Canadian is as full of human nature as any man, therefore he believes in reciprocity and he believes in retaliation. When the duty was put on Canadian lumber by the United States there were a great number of American lumbermen getting out logs in Canada, running them over to the American side and turning them into lumber in the United States.

There was no duty on logs, and this business would have grown immensely had not the Canadian waked up to the fact that he was getting left.

Timber land in Canada for the most part was leased, the leases running one year, it was a sort of unwritten law that these leases should be renewed at the end of each year. As soon as the Canadians found that the American was dodging the tariff, and getting the best of the Canadian lumbermen, they looked about for some scheme to stop this kind of business, and the scheme they worked in Ontario was this: They declined to renew the leases unless these lumbermen would agree to manufacture this lumber on Canadian soil. In many cases the American lumbermen moved their mills onto Canadian soil and continued to get Canadian logs from the leased land in Canada.

The stand that the retail dealer must naturally take in this business is for low-priced lumber. There is no reason why the Canadian should not come here with his lumber on an equal basis with the American lumberman. What the law should be for is the greatest good to the greatest number, and that is really the intention of all law. The forestry people are getting worked up over the depletion of the forests, and this is another reason why the lumber from Canada should not be shut out. Another point in favor is that there are about as many native born Americans in the lumber business in Canada as there are Canadians, and there would be more if it were not for the restrictions of the tariff.—Lumber Review, Chicago.

THE NEWS

Button & Thompson are rebuilding their saw mill at Terranova, Ont.

—James Sparling is building an addition to his planing mill at Meaford, Ont.

—Knight Bros. are building a new wood-working factory at Burks Falls, Ont.

—Craven Langstroth is building a new saw and grist mill at Rothesay, N.B.

Lapointe & Laplante have sold their lumber business in Montreal to Therrien & Gareau.

The Stratford Tile, Brick & Lumber Company, Limited, has recently been incorporated.

—The Sangster-McRitchie Company, Limited, has been formed at Fort Frances, Ont., to deal in lumber.

—A joint stock company has been formed to take over the business of Knight Bros. Company at Burks Falls, Ont.

—Stetson, Cutler & Company have made improvements to their saw mill at Indiantown, St. John, N. B., this spring.

—Mr. McVicar proposes to build a saw mill at Port Elgin, Ont., to have a capacity of upwards 2,000,000 feet annually.

—The Indiana Lumber & Veneer Company, of Indianapolis, Ind., have opened a new warehouse at First ave. and 31st street, New York Cit.

—The New Century Refrigerator Company are rebuilding their dry kiln at Dundas, Ont., which was destroyed by fire about two months ago.

J. A. Hicks & Sons, sash and door factory, etc., Bridgetown, N.S., have dissolved, and a new company has been formed to continue the business under the old name.

—The Galt Petroleum & Chemical Company announce their intention of erecting a \$100,000 wood alcohol plant at Mount Tremblant, in the Labelle district, Quebec.

—The National Supply Company, recently organized in Winnipeg, have commenced the erection of a large warehouse and planing mill at corner of Notre Dame and McPhillips street.

—H. C. Campbell, of the firm of Corey & Campbell, saw mill and sash and door factory, Bedford, Que., recently had the misfortune to have his leg broken by the falling of a pile of lumber.

—At a meeting of the Board of Trade of Port Hope, Ont., held on April 7th, a resolution was passed in favor of a duty of \$2 per thousand feet on lumber imported from the United States.

—It is reported that a new company has been formed to acquire the lumber business of A. & P. White at Pembroke, Ont., and that it is the intention to double the capacity of the mill.

—The Davison Lumber Company, of Bridgewater,

N. S., are building a new mill at Springfield, Lunenburg County. It is expected to have a capacity of 275,000 feet of lumber in 20 hours.

—George Munro, who has conducted a planing mill and lumber yard at Thamesville, Ont., for the last twenty years, has decided to retire and has sold his business to Charles & Wheeler Hubbell.

—Incorporation has been granted to Thos. Myles' Sons, Limited, of Hamilton, Ont., to acquire the lumber and coal and wood business of Thos. Myles' Sons. The capital of the new company is \$170,000.

—The David Gilmour Door Company has lately been incorporated in the State of New York, with headquarters at Buffalo and a capital of \$70,000. This is a branch of the parent company at Trenton, Ont.

—The Scott Lumber Company, of Fredericton, N.B., have made some improvements to their Mag aguadavic mill and have installed a new stock gang supplied by Alex. Dunbar & Son, of Woodstock N.B.

—The Chatham Cooperage Company, Limited, has been organized at Chatham, N.B., with a capital of \$5,000. The incorporators include James L. Stewart, C. D. Ruddock, George Stothart and others, all of Chatham.

—Owing to a large increase in the membership of the Lumbermen's Club of Ottawa, it has been found necessary to remove their club rooms to the corner of Sparks and O'Connor streets, where greater accommodation has been secured.

—T. H. DeCew & Sons, formerly of Essex, Ont., have recently bought Weidmann's stave, hoop and saw mills at Southwold, Ont., together with a fine tract of 600 acres of virgin timber land. They have the mills now running in full force.

—J. R. Booth and the Export Lumber Company have been granted an extension of time for two years for the removal of lumber from their yards which were within the fire area as defined by the by-law passed by the City Council about two years ago.

—J. D. Sowerby & Company, of Oak Bay Mills, Que., are rebuilding their saw mill which was burned last year. They have ordered a 150 horse power engine and a heavy rotary saw mill from the Robb Engineering Company, of Amherst, N.S.

—The Northern Sulphite Mills of Canada, Limited, has been incorporated at Sturgeon Falls, Ont., to manufacture wood pulp, wood alcohol, etc. The capital is \$500,000 and the provisional directors include John Craig, Geo. C. Loveys and Frank Ford.

—An Ontario charter has been granted to the Colonial Veneer, Limited, to carry on the business of a manufacturer of lumber, veneer and boxes. The capital stock is \$40,000 and head office is in the city of Toronto. The provisional directors are B. D. Cole, T. H. Wilson and A. M. O'Brien.

—Incorporation has recently been granted to the Mageau-DeBlanc Lumber Company, Limited, to carry on business as lumber manufacturers at Chapleau, Ont. The provisional directors are Z. Mageau, J. Serre, Oliver Laberge, of Sturgeon Falls, and H. A. West and M. A. LeBlanc, of Chapleau.

—The third annual supper of the employees of the W. C. Edwards Company, Ottawa, which was held

last month, was a very enjoyable event. There were 350 persons present, Gordon C. Edwards presiding. After the supper there were the usual toasts, to which appropriate responses were made.

—The Restigouche Woodworking Company, Limited, was last month incorporated by the New Brunswick Government, with a capital of \$50,000. The promoters are W. S. Montgomery, R. Y. Blackhall, George E. Mercier and A. J. LeBlanc, of Dalhousie, David Richards, of Campbellton, and others.

—The proposed mill of the Carney Lumber Company at Owen Sound, Ont., is now under construction. The contract for the boiler and engine room, machine shop and refuse burner has been awarded to Sinclair & Grier. The burner will be of steel lined with brick and will be 48 feet in height and 35 feet in diameter.

—A New Brunswick charter has been granted to the Canada Woodenware Company, Limited, with a capital of \$24,000, to manufacture all kinds of woodenware, tubs, pails, matches, sashes, blinds, shooks, etc. The incorporators include T. W. Barnes and W. J. Brown, of Hampton, and George C. Weldon, of St. John.

—The Lakefield Furniture & Manufacturing Company has recently been incorporated, with a capital of \$125,000, to establish a furniture manufacturing plant at Lakefield, Ont. J. F. Lillicrap and E. R. Tate, who have been connected with the lumber business in the Lakefield district for many years, are interested.

—George N. Kernohan, for some years the senior partner of the lumber firm of Kernohan & Ferguson, London, Ont., has severed his connection with that firm and established a lumber yard at the corner of Richmond and Bathurst streets, where he has a complete stock of pine and hemlock lumber, lath, shingles, cedar posts, etc.

—On March 29th a provincial charter was granted to the York and Sunbury Milling Company, Limited, to carry on a general lumbering and wood manufacturing business. William H. Murray, of St. John, N.B., Frederick Pond, of Gibson, and J. F. McMurray, Walter Limerick and A. J. Gregory, of Fredericton, N.B., are the promoters.

—An American syndicate are reported to have secured an option on the lumbering property of the William Richards Company, of Chatham, N.B. The option is understood to cover the timber lands, mills, etc. The limits include 166,000 acres along the South-west Miramichi and Taxis river, which is believed to be very suitable for pulp wood purposes. George D. Bayles, president of the Bayles Pulp & Paper Company, is one of the interested parties, and it is assumed to be his object to establish large pulp and paper mills.

—The new factory of the Restigouche Woodworking Company at Dalhousie, N. B., will be completed this month. The buildings consist of a main building 38x150 feet, dry house 40x130 feet, shavings room 40x25 feet, boiler room 40x45 feet, machine shop and engine room, 36x50 feet, warehouse 40x50 feet, and office 50x50 feet. All the buildings are connected on the second storey by bridges. The dry kiln has a capacity of 200,000 feet of lumber per week. The machinery will be driven by a 130 h. p. Robb engine, the steam for which will be generated by two boilers.

C. H. VOGEL

A. M. Can. Soc. C.E.
OTTAWA, CAN. ENGINEER

Surveys, Plans Specifications and Supervision

WATER POWER

Paper, Pulp and Sulphite Fibre Mills

CRAIG MINE CRYSTAL CORUNDUM WHEELS

Our Pure Crystal Corundum Saw Gummars have no equal for their Rapid, Cool, Cutting Properties.



Read the following from Bulletin 180 of the United States Geological Survey, which says:

"Often a distinction is made between emery and corundum, many persons not recognizing emery as a variety of corundum.

Emery is a mechanical admixture of corundum and magnetite or hematite. It is, of course, the presence of corundum in the emery that gives to it its abrasive qualities and makes it of commercial value, and the abrasive efficiency of emeries varies according to the percentage of corundum they contain."

Emery is imported, mined by Greeks and Turks and contains only about 25% corundum. Our Crystal Corundum is guaranteed to be 98% pure alumina, a Canadian product, mined and manufactured by Canadians for Canadians.

HART CORUNDUM WHEEL COMPANY, Limited, Hamilton, Ont., Can.

WARNOCK TOOLS

Best in the World

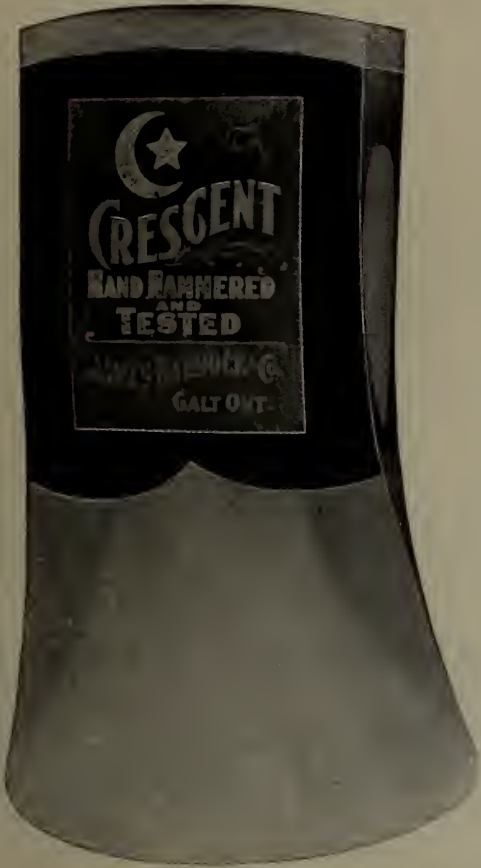

If Strength, Durability, Correct Construction and Lightness are an object, we have the article you are looking for.

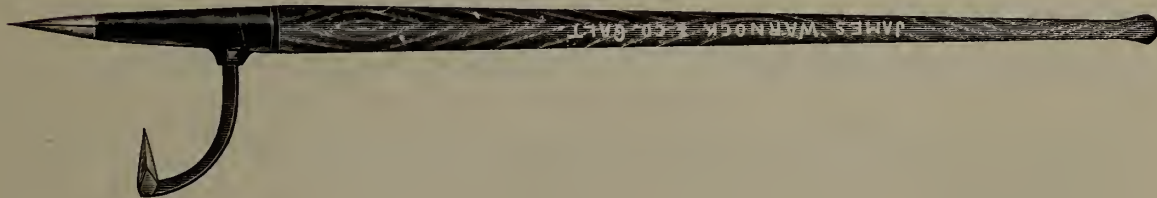
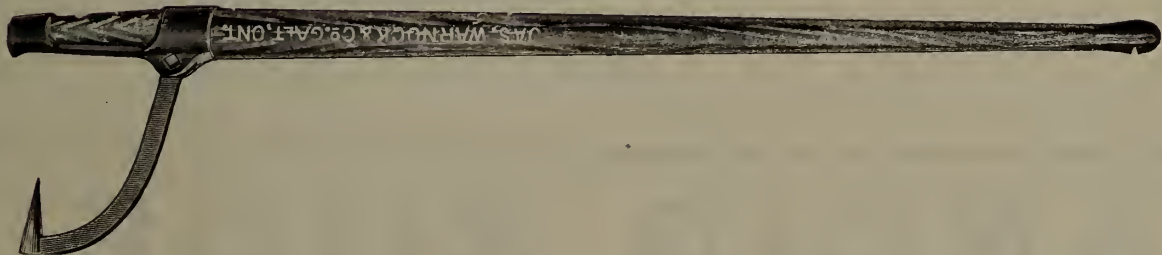

THE JAMES WARNOCK CO., LIMITED
GALT, ONT.

FORESTRY DEPARTMENT

PROPOSED FORESTRY CONVENTION.

A meeting of the executive committee of the Canadian Forestry Association was held in Ottawa on April 26th. Preliminary arrangements were discussed for the forestry convention which was suggested to the annual meeting in Quebec by Sir Wilfrid Laurier. The convention will probably be called by the Premier and will be under the auspices of the Forestry Association. The purpose will be to discuss the forestry problem in general as it affects the Dominion of Canada and the provinces will be asked to cooperate so as to have the convention thoroughly representative of all parts of the country. The varied interests related to or depending directly or indirectly on the forest, such as the lumbering industries, pulp and paper manufacture, agriculture, irrigation and water power, railways, and especially the public interest in the forest, will be given a place on the program. In Canada the subject is one of special interest, as the Governments are such large holders of timber lands and a large part of the government revenue is derived from them. Forestry is therefore a question that comes close to the

tax-paying public and the deliberations and conclusions of such an assembly will be of immense value. The dates and other details of the convention will be arranged after consultation with the Premier.

WHAT DO WE PLANT?*

What do we plant when we plant the tree?
We plant the ship, which will cross the sea.
We plant the mast to carry the sails;
We plant the planks to withstand the gales—
The keel, the keelson, and beam and knee;
We plant the ship when we plant the tree.

What do we plant when we plant the tree?
We plant the house for you and me.
We plant the rafters, the shingles, the floors,
We plant the studding, the laths, the doors,
The beam and siding, all parts that be;
We plant the house when we plant the tree.

What do we plant when we plant the tree?
A thousand things that we daily see;
We plant the spire that out-towers the crag,
We plant the staff for our country's flag,
We plant the shade, from the hot sun free;
We plant all these when we plant the tree.

*From the poems of Henry Abbey, D. Appleton & Company, New York.

H. Cargill & Son, of Cargill, Ont., are installing machinery for the cutting of staves, heading, etc. They are also remodelling their saw mill, which will cut hardwoods almost exclusively in future.

A NEW SAW GAUGE.

"Haste makes waste"—but the sawyer that uses the Loetz Patent Saw Gauge can take an exception to the rule. To combine accuracy and speed was always impossible with the old-fashioned loosen-up-hit-with-hammer affair; its faults we are well acquainted with.

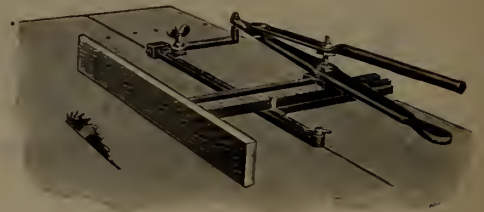

A NEW SAW GAUGE.

The gauge shown herewith is instantly adjusted to any width by simply pressing handles together and setting pointer to required width on scale. The fence is adjustable to keep in line with saw and the gauge may be used on wood or iron table, being fastened by a clever arrangement to any saw table now in use.

Manufacturers that are not equipped with this tool are invited to write the Furniture City Tool Company, Grand Rapids, Mich., who, no doubt, will be pleased to furnish any further information, or place one in your factory subject to a fair test—which always proves that it is a money maker to the user.

Early in April a fire was burning in the cedar timber limits of the Kootenay Shingle Company in the vicinity of Salmo, B. C.

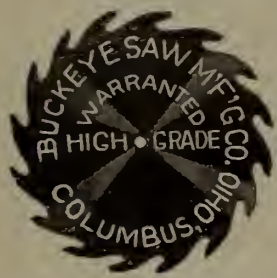

...BUCKEYE SAW M'FG. CO...

MANUFACTURERS OF

High-Grade Saws

Quick and careful work on Repairing.
All kinds of Mill Supplies.

REYNOLDS BROS., Proprietors
267 N. Water Street, COLUMBUS OHIO

Uncle Sam would not allow his battleships to be babbitted with inferior babbitt metal. New Battleship "Nebraska" is lined with Syracuse Babbitt. Always specify best. It is cheapest in the long run.

SYRACUSE SMELTING WORKS

MONTREAL

NEW YORK

SEATTLE

J. J. TURNER & SONS

WHOLESALE MANUFACTURERS OF

LUMBERMENS' TENTS

AND ALL KINDS OF

WATERPROOF GOODS

NOSE BAGS

HORSE BLANKETS, HORSE COVERS, CAMPING GOODS, &c

Our New Factory is the Largest and
Best Equipped of its Kind in Canada.

Corner George, King
and Water Streets

PETERBOROUGH, ONT., CANADA

Long Distance Telephone.

Canoes, Rowboats, Paddles and Oars Always on Hand or Made to Order.

PAROID ROOFING

"IT LASTS"

We are now ready to do business in Canada and want Lumberman dealers in every section. Our proposition will surely interest you and you can add considerable to your profits by handling Paroid as a side line. It does not conflict with your other business but rather helps it.

Paroid for many years has been the standard of quality in the States and Canada. It is adapted to all kinds of buildings in every climate. Send to-day for samples and our special dealer's proposition.

F. W. BIRD & SON, MAKERS, Hamilton, Ont.

Established in East Walpole, Mass., U. S. A. in 1817.

Lumber Insurers General Agency

66 Broadway, New York

OFFERING FACILITIES OF

Lumber Insurance Company of New York

Lumber Underwriters

RATES QUOTED ON APPLICATION

KEEPING A SAW STRETCHER IN ORDER.

Rolls properly ground, that track and travel together, are essential elements in a saw stretcher. Of course, perfect rolls cannot make up for a poorly designed or constructed frame work or for the lost motion to be found in some types of stretchers built with so-called "movable rolls," having feathered rolls or shafts or both. But if the rolls dish the saw, it is an indication that one or the other roll is imperfectly ground or soft or worn more or less, or that the rolls do not travel or track together, or that the roll shafts are not in perfect alignment. If the cause of the trouble lies in the face of the rolls, by reason of their uneven diameter, or wear on being ground on

different segments, the remedy is to accurately regrind them.

Should the rolls not act easily on the saw, with the exercise of ordinary pressure, it is an indication that they are too flat for the temper of the saws in use, and the remedy is to have them regrind on the segments of smaller circles. Moreover, it pays to have the rolls re-ground from time to time and kept in the best condition, as the cost of the work is a mere trifle in comparison with the beneficial results that follow the use of perfect rolls.

Where the rolls are out of true, and to dispense with them would at times work a serious inconvenience, a temporary improvement in

their shape may be effected by the use of a piece of emery cloth.

If the rolls dish the saw downwards—that is, leave the hollow side up—place a strip of emery cloth between the rolls, with the emery side of the cloth up, start the machine, and gradually close the rolls until the emery acts on the upper roll, at the same time holding the emery cloth so that it will not feed through, thus surfacing the upper roll, making it more nearly flat. If the roll dishes the saw upward, reverse the cloth. By a little experimenting the tendency to dish the saw will be partially or wholly overcome, although it will be apparent that if the rolls are already too flat to act on saw with the pressure obtainable, the only thing to do is to have them both re-ground to a proper convex surface.—Packages.

You Can Save Money

TEAS AND COFFEES

Write for Samples

Teas a Specialty for Camp Purposes :—

Japans	-	-	-	-	-	11 1/2	cents and up	per lb.
China Greens	-	-	-	-	-	9 1/2	do.	do.
Black Teas	-	-	-	-	-	12 1/2	do.	do.

Samples on Application to

JAS. RUTHERFORD & CO., 27 Sacramento Street, **Montreal**

Cable Address : CHALLENGE

BRANCH OFFICES FROM OCEAN TO OCEAN

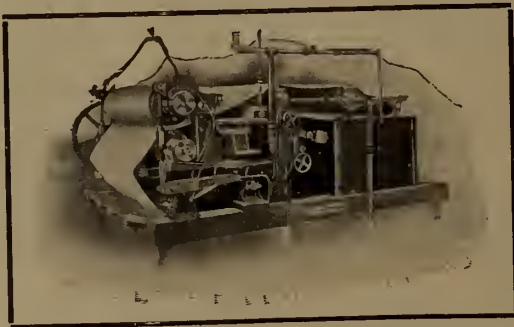

OUR NEW HYDRAULIC WET MACHINE

LIEBERS
CODES : ABC 4th ED.
PRIVATE

THE JENCKES MACHINE CO., LIMITED

CONTRACTORS FOR

Complete Pulp Mill Plants

INCLUDING POWER EQUIPMENT

Estimates Promptly Furnished.

Correspondence Invited.

WORKS AND HEAD OFFICE 48 Lansdowne St.

SHERBROOKE, QUE.

BOILERS FOR ALL SERVICES

Return Tubular, Water Tube, Marine, Lancashire, Etc.



*Engines, "Worthington"
Pumps, Forgings and
Castings of every description*

**THE JOHN McDOUGALL
CALEDONIAN IRON WORKS CO., LIMITED,
MONTREAL**

One of two Marine Boilers built in our shops for the Richelieu & Ontario Navigation Co's Steamer "Carolina." Length 21', diameter 13' 4", height 11' 10", weight 37 1/2 tons.

SOMETHING
NEW
IN
LEATHER BELTING
“**AMPHIBIA**”

**GUARANTEED
ABSOLUTELY WATERPROOF
FOR**

**SAW & PULP MILLS
& ALL WET PLACES**

*WRITE FOR
DESCRIPTION & PRICES*

SADLER & HAWORTH
TANNERS & MFRS.,
MONTREAL — TORONTO.

CORRECTION.

The biographical sketch of Hon. John Sharples, which appeared in the last issue of THE CANADA LUMBERMAN, was written by Mr. Byron Nicholson, Crown Timber Agent, Quebec. The writer's name was misspelled in connection with the publication of the sketch.

THINGS TO BE REMEMBERED.

"Twelve Things to Remember" are given in a paper we were reading the other day:—

1. *The value of time.* Lost capital may be restored, by diligent use of experience; time lost is lost for ever.
2. *The success of perseverance.* "Keeping everlastingly at it" brings the hoped-for result.
3. *The pleasure of working.* The only really unhappy, rich or poor, are the idle.

4. *The dignity of simplicity.* When the "frills" are off the man is "on."
5. *The worth of character.* In the last analysis the only real value is a clear conscience.
6. *The power of kindness.* It wins when all coercive measures fail.
7. *The influence of example.* Practice does more than precept in showing the way.
8. *The obligation of duty.* Your concern should not be so much what you get, as what you do for what you get.
9. *The wisdom of economy.* The man who saves makes more than he saves.
10. *The virtue of patience.* "All things come to him who waits."
11. *The improvement of talent.* Talent is the only capital which compounds itself by exercise.

12. *The joy of originating.* The happiest man is he who does the best thing first. The creative instinct should be encouraged for the pure joy found in its demonstrations. The subsequent financial reward brings no such pleasure as that first sense of having made a new thing or conceived a new idea.

Mickle, Dymet & Sons have made extensive improvements to their saw mill at Gravenhurst, Ont., having installed a 500 h. p. engine.

PAT. OSCILLATING BOB SLED KNEE

Hauls 25 per cent. easier, and wears longer, and is lighter than all others.

THOMPSON MFG. CO., Ltd.,
Grand Bay, N. B.

Comforts for the Lumber Camp

Where Price and Value are Right

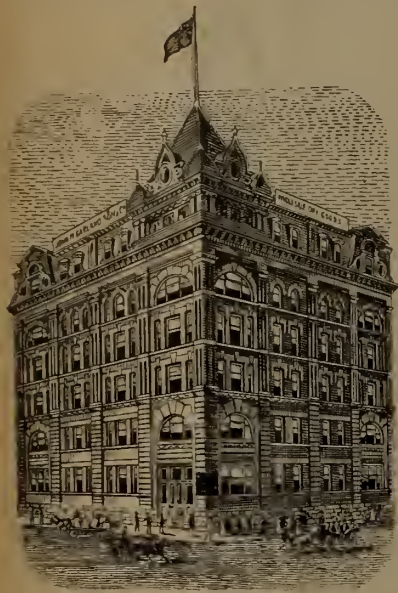

20 OZ. ELASTIC UNSHRINKABLE SHIRTS AND DRAWERS.

Before buying get our price on this line.

RIVER DRIVER'S LONG SOCKS.

3 Special Lines.
\$4.50, \$6.50 and \$9.00 per doz.

HANSON'S FAMOUS 4 AND 5 PURE WOOL SOX

No other make better, none quite so good.

OVER SOCKS.

Blacks and Colors.
Patterns specially designed for the Lumber Trade.

OUR SPECIAL SWEATER

Strong and well knit for Lumbermen's Trade.

MITTS.

Choppers Buckskin.
Hand Made Wool Mitts.
Caribou and Horse Hide.

ETTOFFE PANTS.

16 oz. long and short—well sewn with strong linen.

Leather Belts and Tump Lines.
Moccasins—Laced and Tied.

Lumbermen's Snow Shoes.

TOP SHIRTS.

Made up from extra weight Flannel and Tweed.

UNTEARABLE TWEED PANTS.

This line is a recognized one with our customers, and a sample order will convince every buyer that they are as good as we represent them.

As to SHANTY BLANKETS WE HOLD THE KEY to the best source of supply, all weights. Pillows, etc.—(Strong Ticks ready to use.) Special attention given mail orders. A line to this house will bring you a representative with a full range of samples.

John M. Garland Son & Co.,

Wholesale Dry Goods, Ottawa

LUMBERMEN'S SUPPLIES A SPECIALTY.

T. Long & Bro.,

COLLINGWOOD, ONT.

The Only House in Canada that can supply you with everything you require for an Up-to-date Lumber or Mining Camp from their own stock, at Lowest Prices for Highest Quality of Goods.

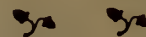

All orders shipped immediately and packed the way you want them. Write or wire for quotations. Try us for your requirements this year. We will save you money.

WHOLESALE GROCERIES AND VAN GOODS.

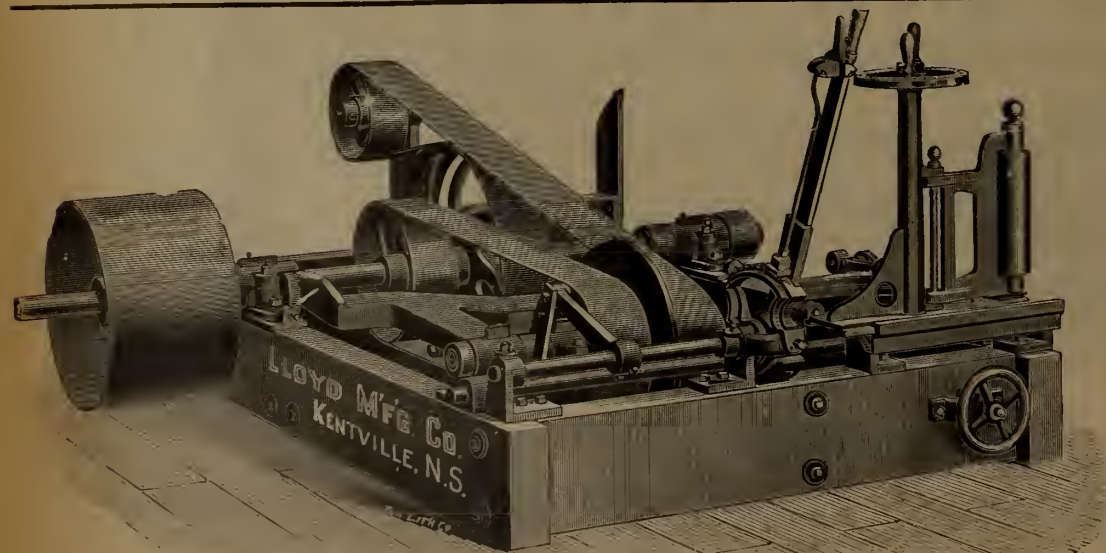

Lloyd Manufacturing Co'y JOHN I. LLOYD, Proprietor.

SAW MILL OUTFITS

Pulp Machinery, Belting, Etc.

OUR SPECIALTIES:

- Band Saw Mill Machinery,
- Improved Rotary Saw Mills,
- Also Screw Post Dogs,
- Turbine Water Wheels,
- Power Feed Gang Edgers
- Buzz and Surface Planers,
- Heading Rounders,
- Stave Machines, Stave Jointers
- Stave Planers.

KENTVILLE, N. S.

THE LUMBERMEN'S CLUB OF OTTAWA.

The Lumbermen's Club, which was organized in Ottawa in July, 1904, appears to be making rapid progress, notwithstanding the fact that the lumber firms had all commenced another season's operations, and consequently their officials had nearly all left for the scene of their up-river work. With the beginning of the manufacturing season, an effort is being made to interest all the mill and yard superintendents, cullers, shippers, etc., connected with the lumber mills.

The annual convention, which takes place

in Ottawa on July 19th, promises to be a "red-letter" event with all members, and will be in the nature of a re-union also. A programme is being prepared for the afternoon, and after the election of officers in the evening, a banquet will be held in one of the leading hotels. The following day a special chartered train will convey all members to Montreal and return.

T. R. Case and W. K. Chandler, who have been the pioneers in the importing of American lumber into Manitoba under the firm name of Case & Chandler, have organized a new company, known as the Case, Chandler Company, Limited. The capital stock is

placed at \$50,000 and the head office will be in Winnipeg. The company will carry on a general lumber business.

G. T. KNIGHT & SON

Manufacturers of

Building Supplies

we make a specialty of
Doors and Sashes; Mouldings and all kinds of turned goods.

Address, MEAFORD, ONT.

P. PAYETTE & CO.

Manufacturers of Saw Mill and Engine Machinery and all kinds of Marine Machinery.

PENETANGHISHENE, ON



These Mules Cannot Break This Yarn

BECAUSE IT WAS MADE BY THE

Consumers Cordage Co., Limited

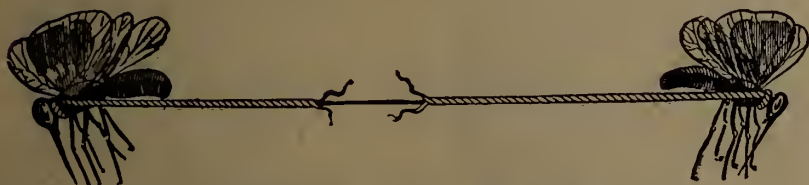

Poor Yarn is Dear at Any Price

We Manufacture

**Double and Single Lath Yarn,
Shingle Yarn, and Cordage**

Of Every Description

Our mills are equipped with the latest improved machinery for making extra long lengths of Transmission Rope.

CONSUMERS CORDAGE CO., LIMITED

Montreal and Halifax

WE ARE AFTER YOUR

Sprocket Chain

Trade on the Strength of

The large Stock we keep
The favorable Discounts we quote
The quality of our goods
20,000 to 30,000 ft. in our warehouse
at Winnipeg.

THE

Manitoba Iron Works

LIMITED

Manufacturers and Dealers in Saw-Mill Machinery,
WINNIPEG, MAN.

THE LUMBER MUTUAL FIRE INSURANCE COMPANY

BOSTON, MASS.

STRENGTH

NET ASSETS, MARCH 31, 1904

\$614,489.91

ECONOMY

DIVIDENDS TO POLICY HOLDERS

33 $\frac{1}{3}$ %

MAIL EXPIRING POLICIES WITH YOUR ORDER.

AMENDMENTS TO LOG DRIVING ACTS.

The Crown Lands Department of Ontario has been asked to amend the log-driving acts of the province, and particularly that one referring to the Moira River and its tributaries. The movement for a change has grown out of a dispute regarding rights on the Moira river. Joseph James has an asbestos mill and actinolite works on the Scootamata River, a tributary of the Moira. To supply power to these industries he erected a dam across the river. To accommodate the raftsmen he provided a "slide" in the dam, down which the logs could be taken. According to his story, the freshets last spring injured the dam and slide, and before he could make repairs a

raft of logs of several thousand pieces came sweeping down the Scootamata, and was allowed to form a regular blockade at the injured dam. Finally, he says, the Rathbun Company blew up the dam with dynamite, 32½ sticks of it being used at one point. The report from that explosion on June 1st last was terrific and was heard, he says, at great distances. The dam material and logs were thrown to a great height, and the buildings nearby somewhat damaged. However, the logs were released, and went surging down stream to be collected at a point near the Moira. The company, it appears, claims that Mr. James had no right to place any obstruction in the river, Mr. James, on the other

hand, contending that the dam was constructed in strict accordance with the requirements of the law. Negotiations for a settlement out of court failing, Mr. James entered action against the company for unstated damages. These include the cost of the dam and the loss of business owing to the works having been closed since the explosion.

The Deer Lumbering Company, Limited, has recently been formed to operate in Newfoundland. The company have acquired control of over 300 square miles of timber areas in the island, situated around Deer and Grand lakes, in the basin of the Humber river. A. A. Chisholm, of St. Andrews, N. S., has been appointed manager of the company.

The Cook & Bros. Lumber Co.
Of Ontario, Limited
MILLS at SPRAGGE, Algoma Dist., Ont.
on "See" Branch C.P.R.
OFFICES (Manning Arcade, Toronto
Coristine Building, Montreal
And at Mills at Spragge.

MANUFACTURERS OF

White and Red Pine Lumber and Lath

Water Shipments

FRANK DENTON, K. C. HERBERT L. DUNN
W. MULOCK BOULTBEE.

DENTON, DUNN & BOULTBEE
Barristers, Solicitors, Notaries, etc.
National Trust Chambers. TORONTO

THE MONTHLY JOURNAL
Concrete

Devoted to cement manufacture and the various forms of concrete construction.
\$1.00 a year; single copy 15c.
CONCRETE PUBLISHING Co., - Detroit, Mich.



Sole Canadian Agents Prices Reduced
WATEROUS, BRANTFORD, CANADA

OILS

Manufacturers High-grade Cylinder, Machine and Sawmill Oils.

Calypsol Grease

for Sawmill Purposes a Specialty.
Our products are made from finest Pennsylvania stocks.

We solicit your correspondence.

St. John St., MONTREAL.
Offices and Works:
Manchester, Eng.
Hamburg, Germany.
Newark, N. J.
Chicago, Ill.
Commercial Oil Co.,
Hamilton, Ont.

SHERMAN'S FLOORING MACHINES
PATENTED

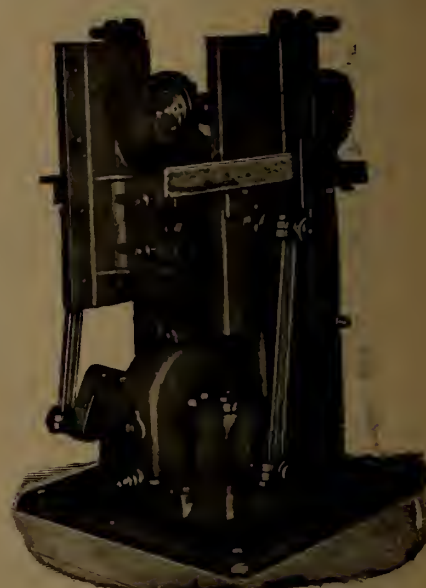

Above cut shows our End Matcher, the best machine in the market for end matching flooring strips. They do rapid and accurate work, and are durable—therefore used by leading flooring manufacturers. Make your flooring profitable by end matching it.

We Make the

SHERMAN SIDE BORING MACHINES

and the
SHERMAN FACE BORING MACHINES

To bore flooring while it is being run on the flooring machine. Write for circular and list of users.

W. S. SHERMAN CO.

1150 Holton St., Milwaukee, Wis

FOR THE CAMP TABLE

- | | |
|---------------------------------------|--------------|
| Mess Pork | Smoked Hams |
| Short Cut Pork | Roll Bacon |
| Plate Beef | Pure Lard |
| Dressed Fresh Beef | Pork Sausage |
| Long Clear Bacon, Butter, Cheese, &c. | |

Write us for Special Prices on Car Load Lots.

THE PARK BLACKWELL CO., L'T'D

PORK AND BEEF PACKERS
TORONTO

Normandin Cement Block Machine



There's
Money
in the
Block Business

Experience not
Necessary for
Success.

The
NORMANDIN
machine
does the work.

THINK IT OVER, and decide quickly to start a Block Yard in your town. Others are making a success of the business—You can too. Write to-day for particulars of the **NORMANDIN MACHINE**. Hundreds of them in use daily. Hand labor and a little common sense will turn out a perfect stone on the **NORMANDIN**. This is the machine that took the Highest Award St. Louis Fair, 1904. The United States Government Engineers will buy nothing but the best—they bought and are using the **NORMANDIN**—IT MUST be right.

The **NORMANDIN** complete equipment comprises over 200 parts and weighs 3,000 lbs.

SOLE AGENTS FOR CANADA

The Cement Block Building Co., Limited
Winnipeg Vancouver Toronto
Largest Cement Block Manufacturers in Canada



THE MERCHANTS RUBBER COMPANY, Limited
BERLIN, CANADA



OATS

Write or wire us for quotations. We make a specialty of shipping to Lumbermen in bulk or sacks Delivered at any point in the Dominion.

THE NORTHERN ELEVATOR CO., Limited
WINNIPEG, MANITOBA
N. BAWLF, President.

TO THE LUMBERMEN OF CANADA

We make a specialty in **Grey Blankets** for Camp use. Why not ask us to submit sample pairs before placing your order for coming season's requirements

ONTARIO BLANKET CO.
COLLINGWOOD, ONT.

MILLS AT CLARKSBURG

The James Smart Mfg. Co., Limited

BROCKVILLE, ONT.

Western Branch :
131 Bannatyne Ave. East, WINNIPEG, MAN.



(OAK LEAF PATTERN.)

MANUFACTURERS OF . . .
High-Grade Chopping Axes,
Mauls, Wedges, Brush Hooks, Etc.

Catalogues and all information promptly furnished.

OUR



A GUARANTEE OF EXCELLENCE

OXFORD VULCAN

—A HEAVY STOVE FOR—

Logging Camps, Railroad Construction Gangs, Boarding Houses, Etc.



See Our Camp Tubular Stove in Three Sizes.

The Vulcan is a Stove made for heavy work and rough usage.

Provided with 6-10" Cooking Holes—28" Fire Box—8 x 8 1/2" Fire Door—Oven, 25 x 28 x 16".

The Body is made of extra heavy steel.

The Top and Fire Box linings exceptionally heavy.

Reservoir of 15 gallons capacity.

THE GURNEY FOUNDRY CO., LIMITED

TORONTO, ONT.

The GURNEY MASSEY CO., Ltd., MONTREAL.

The GURNEY STANDARD METAL CO., Ltd., CALGARY, ALTA.

WINNIPEG, MAN.

VANCOUVER, B. C.

WRITE FOR PRICES

SHALLOW - RIVER - NAVIGATION

100 Foot River Steamer Designed by Marine Iron Works.
(From Photograph.)

Our knowledge of river navigation is earned through long experience and exceptional opportunity. We design the boat and build the ENTIRE AND COMPLETE outfits of driving machinery for powerful light-draft vessels, having the best of modern shop facilities to aid us in doing ALL the work. Write to us before you act.

MARINE IRON WORKS **Station A.** **Chicago, U.S.A.**

Horse Sense

Could be taken to mean Common Sense in the treatment of your horses. All Lumbermen depend largely on the efficiency of their horses. This can easily be maintained if

Johnson's Veterinary Remedies

are used.

The following valuable preparations have been largely in use amongst the Lumbermen of the Dominion for years. They are put up in bulk and are therefore more economical than similar lines, as the cost of packages, bottling, etc., etc., is saved:

Johnson's Horse Liniment No. 1

A penetrating Alcoholic Liniment for Sprains, Strains, Bruises, Swellings, Lameness, Curbs, Splints, etc., etc., \$4.50 per Imp. gallon

Johnson's Horse Liniment No. 2

An excellent Oil Liniment for the same purpose, \$3.00 per gal'on.

Johnson's Horse Colic Remedy

An absolutely safe and quick remedy for Colic of all kinds, \$5.00 per Imp. gallon.

Johnson's Veterinary Healing Ointment and Gall Cure

Positively the best all around Healing preparation on the market for Cuts, Corks, Sore Shoulders, Wounds, Galls, Scratches, etc., etc., \$2.25 per 2 pound tin. Put up in 4 ounce tins if preferred. Special prices for quantities—Ask your lumbermen friends about this King of all Gall Cures.

Ten per cent. discount off orders amounting to \$50.00 or upwards. A full stock of all drugs and patent medicines kept always on hand at lowest wholesale rates. Correspondence solicited. Orders by mail receive special attention. Let me figure on your requirements.

A. H. JOHNSON

WHOLESALE DRUGGIST

COLLINGWOOD, ONT.

ADAM HALL PETERBORO, ONTARIO, CANADA

MANUFACTURER
OF

STEEL RANGES

For Lumbermen's and Railway Camps, Boarding Houses and Hotels

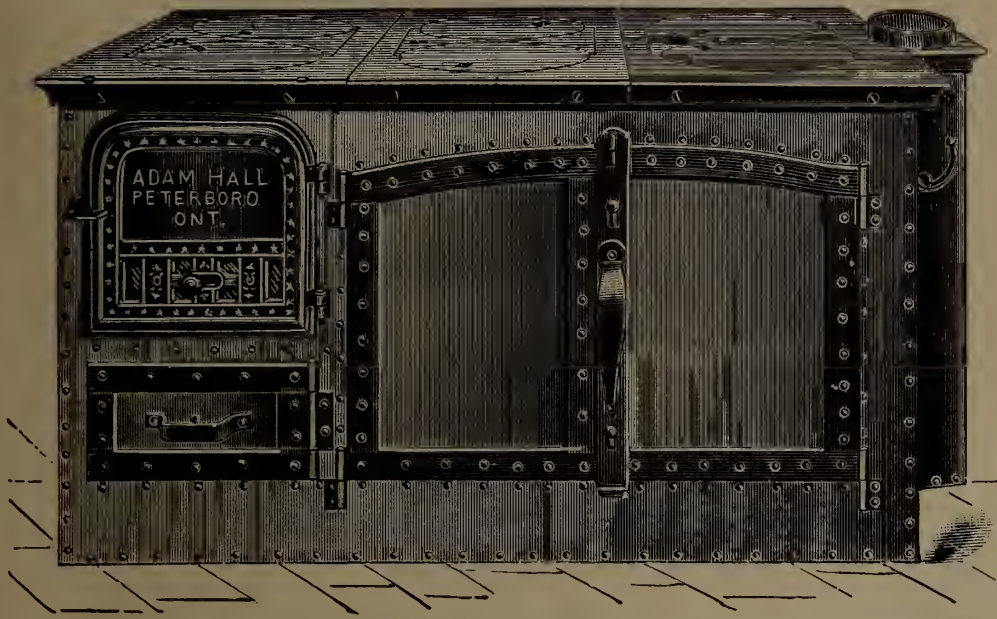

Lumbermen's Six Pot Hole Range.

We have been manufacturing Steel Ranges and Heaters for Lumber Camps for the past Twenty-four Years, and have supplied the wants of nearly all the Lumbermen in Quebec, Ontario and Manitoba—they are unexcelled for Baking and Cooking, and are strong and durable.

This No. 1025 Six Pot Hole Range is largely used in Camps of Fifty (50) Men and for use when driving the Rivers. Weighs 400 pounds.

This No. 1025 Range with 25 Gallon Copper Reservoir is the one we sell the most of, owing to the convenience of having a supply of hot water at all times. Will cook for 50 to 60 men. Weighs 450 pounds.

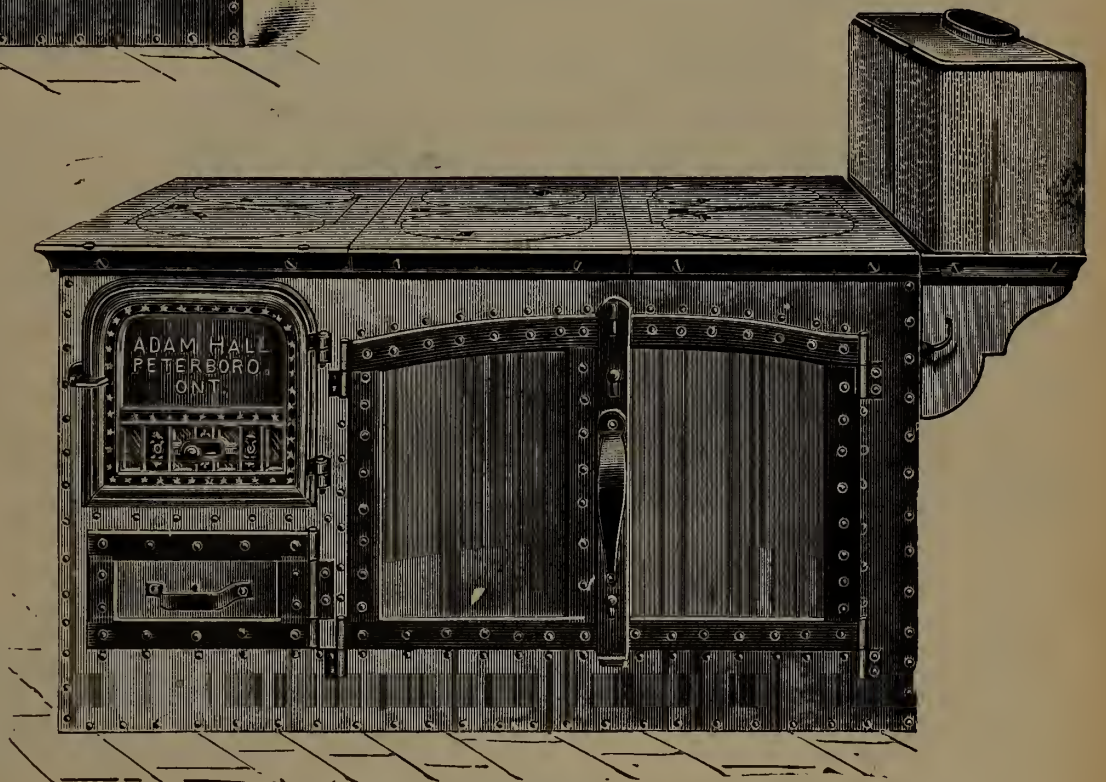

Lumbermen's Six Pot Hole Range with Reservoir.

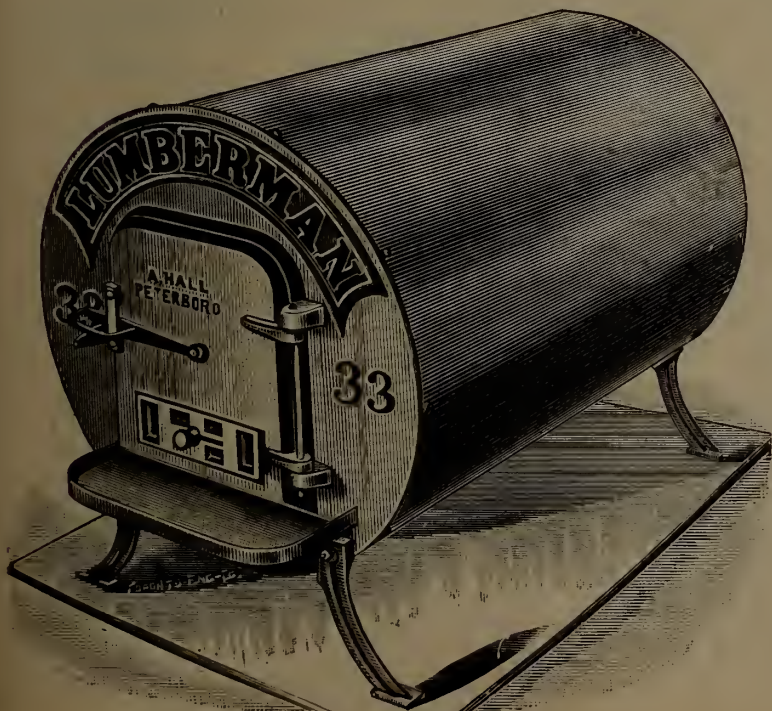

The Lumberman's Heater.

The Lumberman Heater

In three sizes—36 in. long, 42 in. and 48 in. This heater is used in heating Lumberman's Camps, Boarding Houses, School Houses and large buildings.

The body of the heater is made of heavy boiler plate. The ends are made of heavy cast metal with large fire door. It is a perfect heater and very durable.

Write for Catalogue and Price List

THE DYMENT FOUNDRY CO.

BARRIE, ONT.

Manufacturers of

ENGINES, BOILERS, STEAM FEEDS

AND A COMPLETE LINE OF

SAW, SHINGLE AND LATH MILL MACHINERY

Can ship mills in a week's notice. Write us for prices and catalogue.

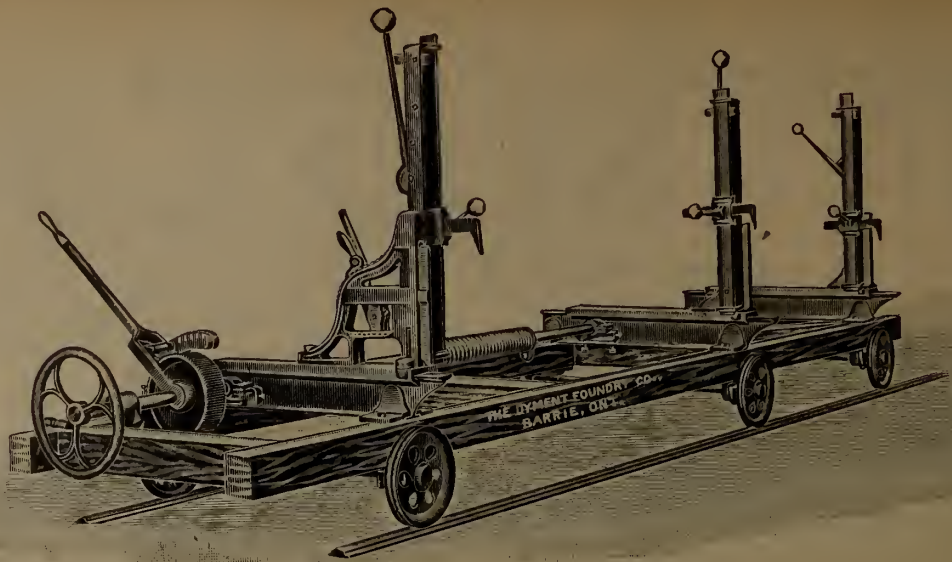

This is a light running Carriage and is quite suitable for small mills. Its capacity is about 15,000 feet per day. The wheels are 14 inches in diameter. The axles are $1\frac{3}{4}$ inches in diameter and go across frame. They are fitted with self-oiling boxes. The bunks are of steel. Blocks will recede 38 inches. An overset lever is supplied when desired, also spring receder and band brake wheel.

The feed on this frame is self-contained and can be used for either rope or rack and pinion. All the frictions have 7 inch face, two of them are made of paper, the other two of iron. The mandrel is made of steel and is 3 7-16 inches in diameter. The mandrel pulley is made in different sizes so as to suit the speed and width of drive belt. If desired this pulley may be put inside of frame.

WE MANUFACTURE AN IRON SAW FRAME

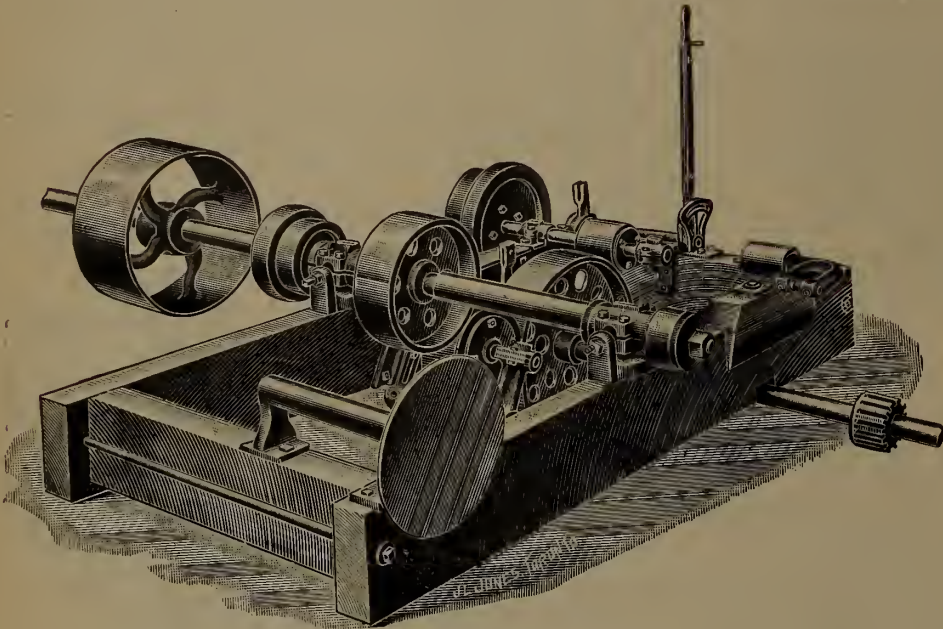

DRAKE'S IMPROVED "SWING" SHINGLE AND HEADING MACHINE

THE "Swing" or Carriage frame is made from steel angle bars. Light and strong Will take in blocks 16 in. wide. Set works have automatic tilt, and are easily adjusted for thick or thin Shingles or Heading.

Jointer may be driven from saw arbor if desired.

Write for further particulars and get our low down cash prices before ordering elsewhere.

*The Cheapest
Good Machine*

*The Best
Cheap Machine*

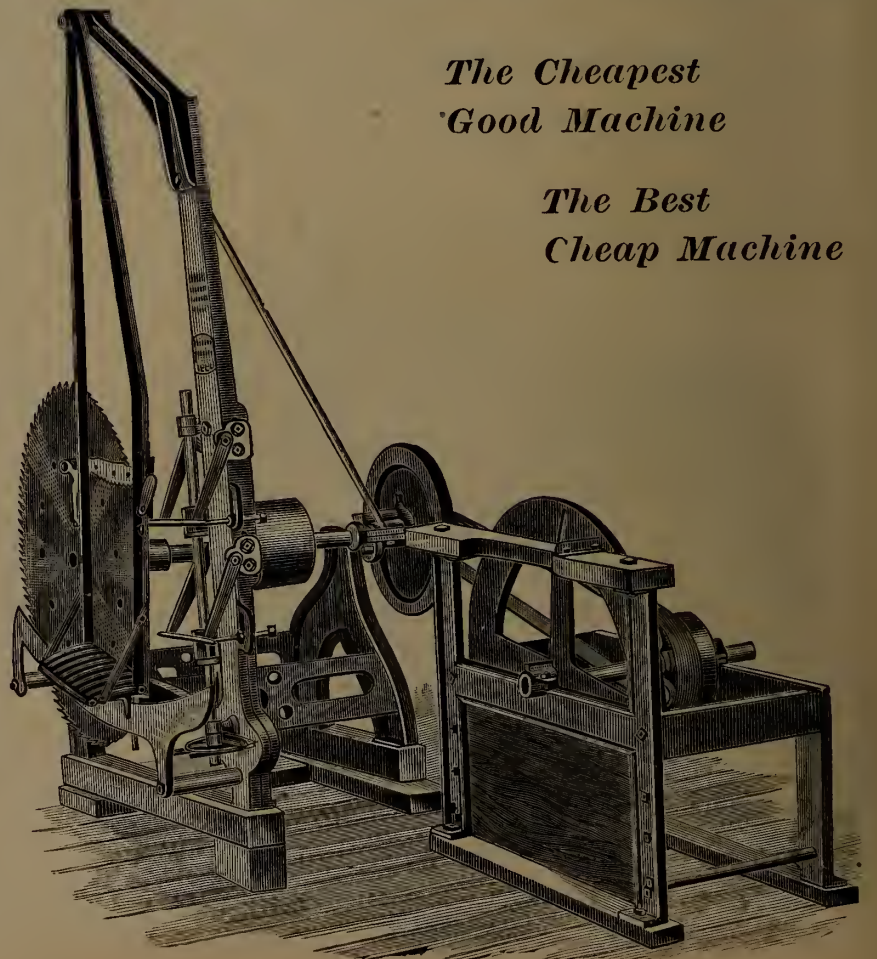

F. J. DRAKE - - Belleville, Ont.

ATKINS ALWAYS AHEAD!



QUALITY IS THE THING!

Substance, not the Shadow of Quality

Characterizes the Silver Steel Saws bearing the celebrated "AAA" trade mark. Superiority of material, our patent process of tempering, perfection of grinding and experience and skill in workmanship are the leading features in the make-up of an Atkins Saw. These qualities insure perfect running saws and satisfaction to the user. The highest intrinsic value ever offered and the most efficient service possible to obtain are secured when you purchase an Atkins Saw. A trial is convincing proof. Think it over and let's have your order now.

Our Machine Knives, too, are made with a view of retaining you as a permanent, satisfied patron. What more can we say?

Mill Supplies of every description. Write for our 1905 Saw and Saw Tool Catalogue and Sawyer's Hand Book. It's free.

E. C. ATKINS & CO., Inc.,

Leading Manufacturers of Circular, Band, Cross-Cut, Hand and Wood Saws, Etc.

Factories and Home Office,
Indianapolis, Ind.

Canadian Branch,
56 King St. East, Toronto, Ont.

THE E. L. PURVIS CO.,
18 COLBORNE ST., TORONTO, ONT.



PIPE AND BOILER COVERINGS

Asbestos Mineral Wool
and all kinds of Fireproofing

Material Agents for

FAMOUS MICA COVERINGS

Fire Clay Products

THE GLENYARDS FIRE CLAY CO.

BONNYBRIDGE, SCOTLAND.

Cablegrams: Glenyards, Bonnybridge.

Codes used, A.B.C. and Glenyards.

Manufacturers of all kinds of **Fire Clay Goods, Ganister and Silica Goods**, for **Iron and Steel Works and Gas Works**, including **Boiler Seating Blocks and Covers** of all sizes. **Ground Fire Clay, Ganister and Silica** in all kinds of Packages

Don't Hurry---Just Keep Moving

Operators of Shaping Machines—and others who know—will tell you that one-half of their time is devoted to "fitting up" and "getting ready."



OUR "SOLID STEEL SHAPER CUTTERS"

(GUARANTEED)

Are used by manufacturers who by experience know that the "first cost" is very small compared with the "continual cost" when "open heads" are used. OUR CUTTERS are always ready for use, which means "always something doing" on the Shaping Machine.

In ordering—send sample of mould, diameter of spindle, and size of cellars.



**Furniture City
Tool Company**

189 CAMPAU STREET, GRAND
RAPIDS, MICH., U.S.A.

AGENTS—
Harron, Rickard & McCone, San Francisco, Cal.
Schuchardt & Schutte, Berlin, Germany



IN OUR LINE WE LEAD

McFarlane Patent Wrot Forged Steel Socket Cant Dogs

Leads them All

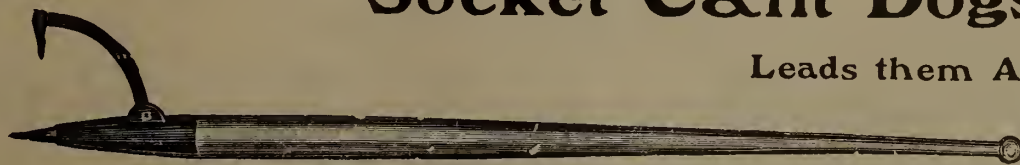

Used in every Lumbering District from the Atlantic to the Pacific Ocean

Extra Fine Quality Split Rock
Maple Handles

Round and Duck Bill Peaveys and
Cant Hooks

Write for quotations. If once used you will never return to the old malleable sockets.

THE McFARLANE-NEILL MANUFACTURING CO., Limited ST. MARY'S, YORK COUNTY
New Brunswick

AMERICAN NO. 1 SELF-FEED RIP SAW TABLE

Capacity 20" Wide by 6" Thick

FEED— Strong and Positive.

The rolls are adjustable, lay close to a 10 in. saw and expand to take in a 20 in. saw.

Table is raised or lowered to desired position by one movement of crank.

The Feed Works are likewise so controlled.

For full detail information, catalogue and prices address

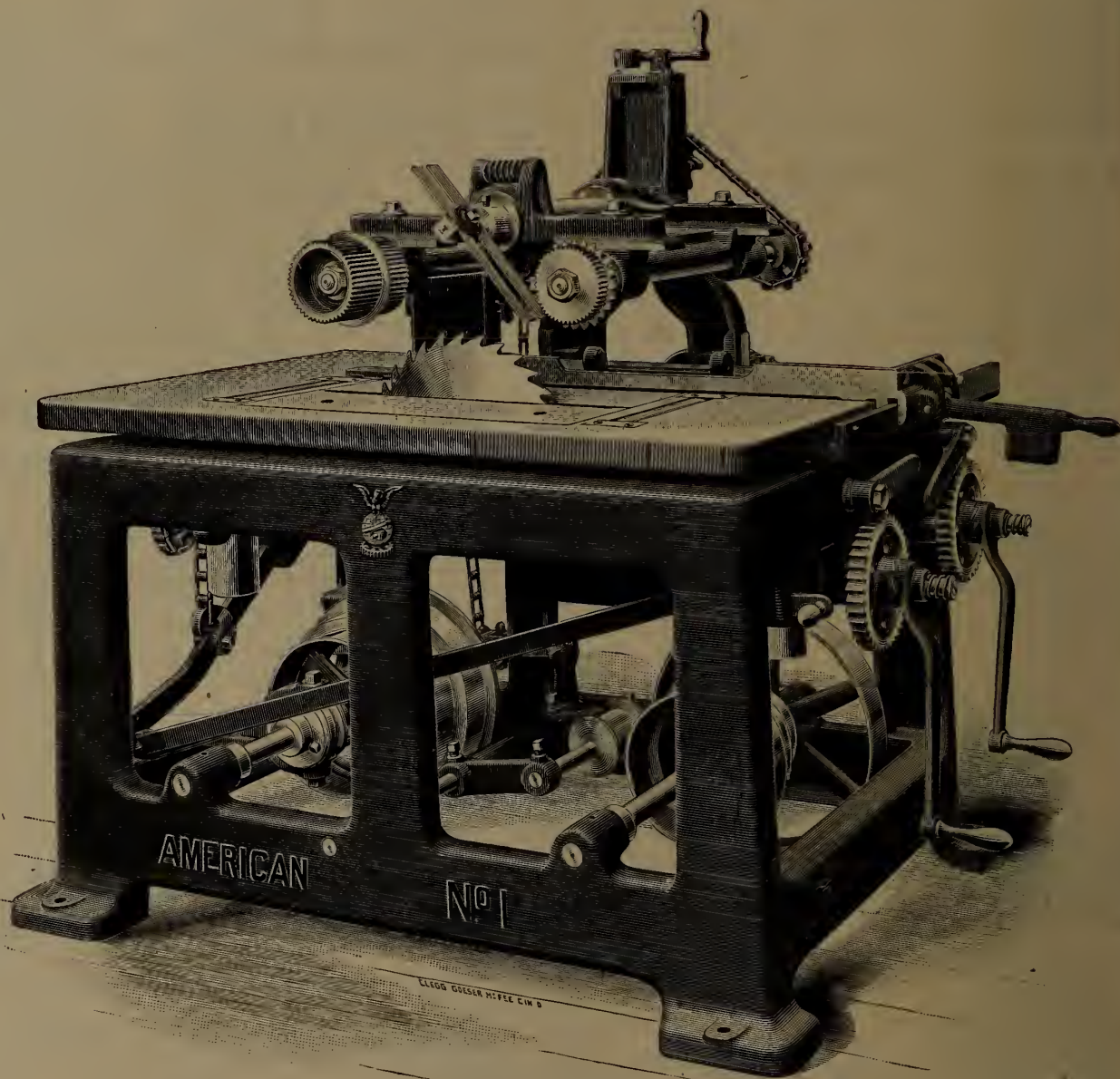
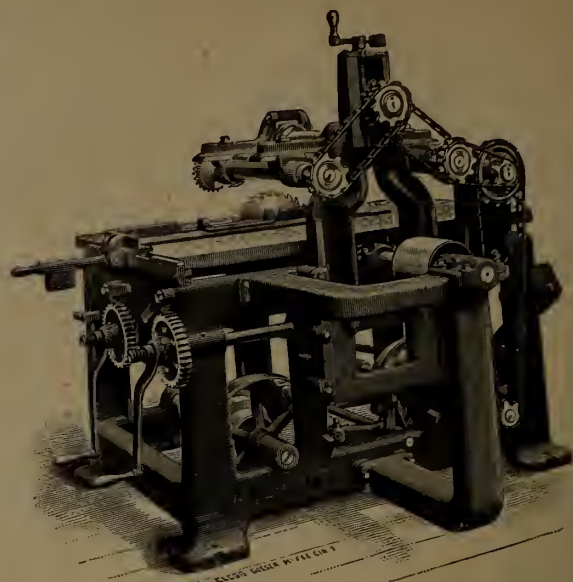

**American
Wood-Working Machinery
Company**

136 Liberty Street, NEW YORK CITY

Sales Agent—THE CANADIAN FAIRBANKS CO., MONTREAL



IT'S OUT

Our New XXXX Catalog is just out, showing and describing the most complete and comprehensive line of Hand and Power Feed Shingle, Heading and Box Board Machinery ever created. This book is

YOURS FOR THE ASKING

and should be in the hands of every manufacturer of Shingles, Heading or Box Boards in the country. A postal request brings it.

PERKINS & CO.
GRAND RAPIDS, MICH.

WHEN YOU HAVE TO 'Wait for Steam to Rise'

Your men loaf, Your machines are idle, Your work stops, Your production ceases.
BUT YOUR EXPENSES GO ON.

STOP IT! HERE IS YOUR REMEDY



THE GORDON HOLLOW BLAST GRATE

No waiting for steam to rise with this grate. Burns your wet, green or frozen sawdust or refuse, generating every ounce of power your boilers are capable of developing. Will give you from 80 to 100 lbs. steam pressure where you have been unable to obtain more than 60 or 70 lbs. It thus makes two boilers do the work of three.

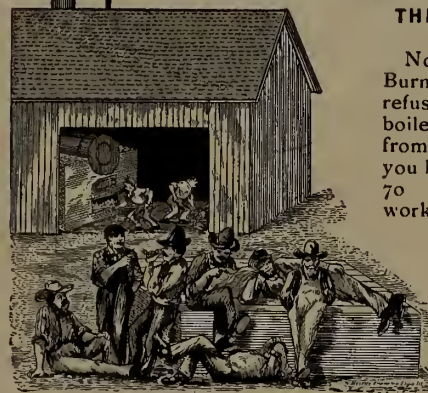

With this grate you INCREASE your earnings because it always gives you all the steam you need, thus keeping your men at work. With it there is no such thing as SHUTTING DOWN TO WAIT FOR STEAM TO RISE.

It frequently PAYS FOR ITSELF every month.

The Gordon Hollow Blast Grate Co., Greenville, Mich.

Established 1889
The largest manufacturer of Blast Grates, Edgers and Trimmers in the World.

SEND FOR CATALOGUE D.



The "Alligator" Steam Warping Tugs

SIDE WHEELS OR TWIN SCREWS

The Twin Screws are arranged with flexible joint to raise up in crossing portage

MANUFACTURED BY

WEST & PEACHEY, - Simcoe, Ont.

Cables carried in stock for renewals

Do You Know

That we have the best Foundry and Machine Shop north of Toronto and that we ship our goods to all parts of the Dominion of Canada. We build up-to-date Machinery of all kinds used in a Saw or Shingle Mill. We can supply you with anything that you require for mill use. We make no shoddy goods, all our goods are warranted to please. Our prices are reasonable. Send for our catalogue and prices, tell us just what you want. We will help you out.

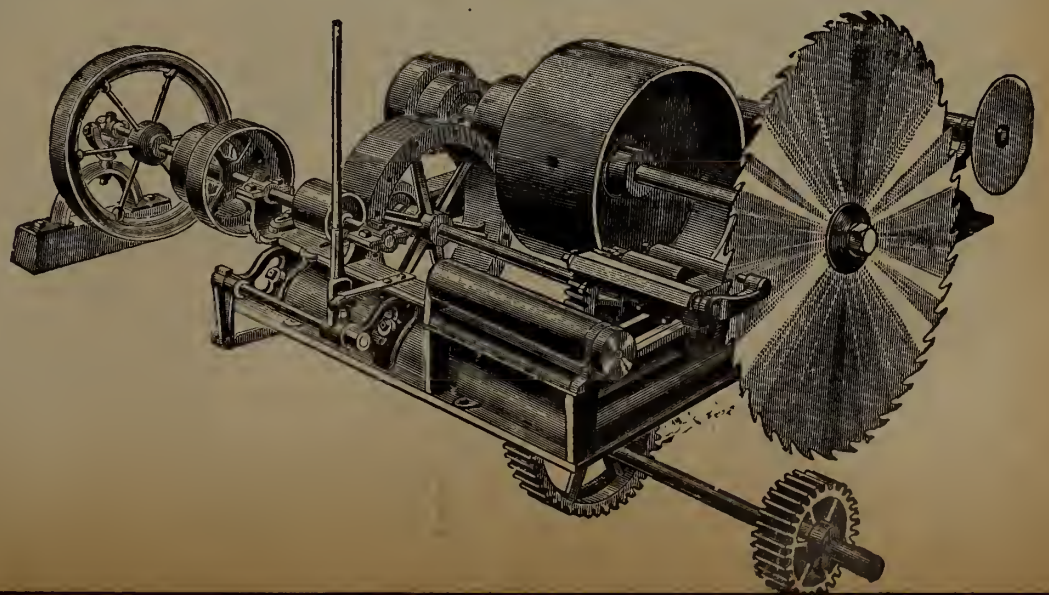

B. R. MOWRY & SONS,
GRAVENHURST, ONT.



IS EXPERT WORKMANSHIP

MANUFACTURERS OF INSERTED, SHINGLE, AND ALL SOLID-TOOTH CIRCULAR

SAWS

WHAT THE LEADING MILLMEN SAY OF OUR SAWS:

A. J. BURTON SAW CO., CITY.

VANCOUVER, B.C., MARCH 25TH, 1905.

DEAR SIR,

Since you commenced your Saw manufactory here, we have been users of your Saws in various parts of our plant, and we have yet to experience a failure in any saws we have got from you, all of them are running well and giving good satisfaction.

We have been hoping for years past that a Saw manufacturing plant would become established in Vancouver, and are glad that you have made so successful a start, and also glad to hear from other Lumber and Shingle Manufacturers that your Saws have been very satisfactory.

We wish you every success,

Yours truly,

PACIFIC COAST LUMBER CO., LTD.
(SIGNED) J. G. SCOTT, MANAGER

HOE BITS AND SHANKS AND ALL FILE-ROOM SUPPLIES
OLDHAM BAND SAWS

Repairs Executed Promptly. Inserted Tooth Saws Remilled and Refitted

THE TWENTIETH CENTURY SAW

OVER 40,000 IN USE
BEWARE OF IMITATIONS

THE GENUINE IS MADE ONLY BY

R. HOE & CO.,

504-520 GRAND ST., NEW YORK, N.Y.

The Shimer Cutter Heads

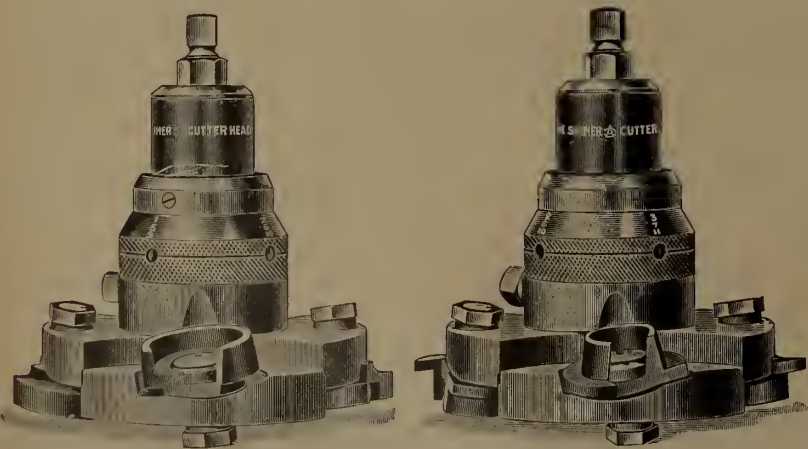

The expense that enters into the every day make-ready of the ordinary Cutter Heads is relegated as a thing of the past the minute you begin the use of The Shimer Cutter Heads.

The Bits have the shape of the pattern—a fixture in line with the cut, protected by the valuable clearance feature—the concave bit seat.

A very clear description is given in our latest Catalogue, No. 26, a copy of which we will be pleased to mail you.

SAMUEL J. SHIMER AND SONS

Milton, Pennsylvania

RODGERS IRON MFG. CO.

MUSKEGON, MICH.

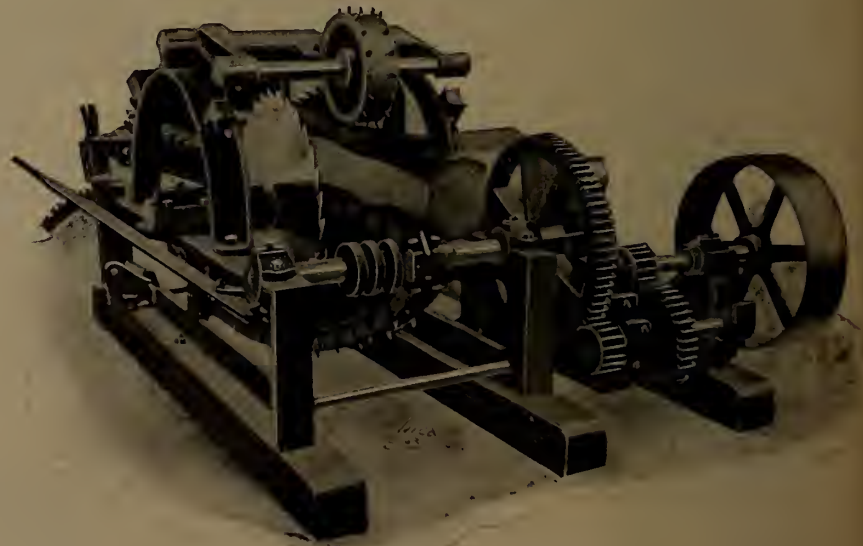

ADJUSTABLE LOG SIDER OR TIE MACHINE

A Money Maker Write to Us
We Will Tell You All About It



Berkley, Norfolk, Va., Sept. 8th, 1904.

Rodgers Iron Mfg. Co.,
Muskegon, Mich.

Gentlemen:—

In regard to the adjustable log siding machine which we purchased of you, it is far beyond our expectations. We are now running 36" saws and have no trouble in slabbing our logs from 6" to 20" in diameter. We consider the machine one of the best of the kind on the market; in fact we know of no machine which will equal the one which we have. It is giving entire satisfaction, and we would be glad to show it to any parties who may be interested if they will call at our mill.

Yours very truly,



Fleming, Centre Co., Pa., March 11, 1905.

Rodgers Iron Mfg. Co.
Muskegon, Mich.

Gentlemen:—

Replying to yours of recent date and referring to your Tie machine, we are cutting from 1,000 to 1,200 mine ties, 5 feet long, per day, with a 25 horse power engine.

Respectfully

Perfect Swing Shingle Mill

Fitted with our "Automatic Trip."

Best Swing Shingle Machine on the Market today for cutting Shingles, Headings, Etc. . .

It will pay you

to write for description and price before placing your order.

We also Manufacture a complete line of . . .

SAW MILL MACHINERY, ENGINES AND BOILERS

THE **Owen Sound Iron Works Co. LIMITED**
Owen Sound, Ont.

SEND FOR CATALOGUE

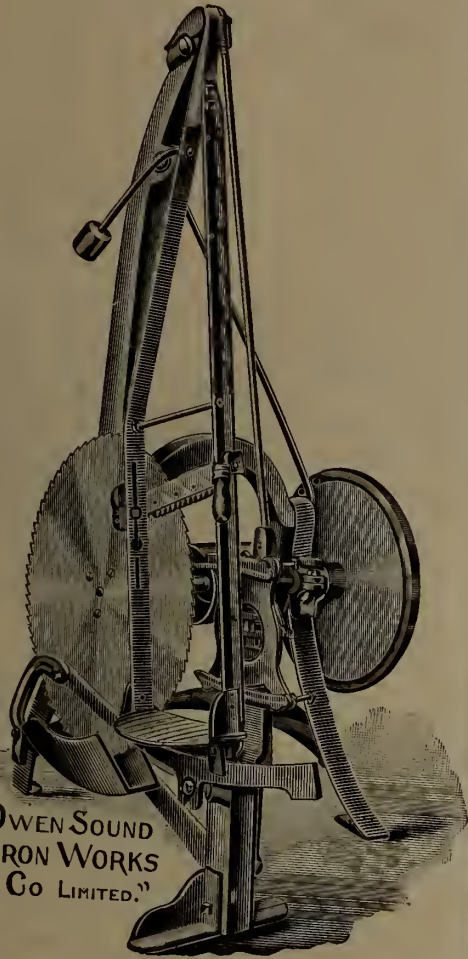

"OWEN SOUND IRON WORKS CO LIMITED."

RUBBER BELTING

For
Transmitting
Elevating
and
Conveying



Rubber
Hose
for
Water
Steam
Air
Suction
Fire
Protection

THE CUTTA PERCHA & RUBBER MFG. CO.
OF TORONTO, LIMITED.

HEAD OFFICES: 47 YONCE STREET, TORONTO, CAN.

Branches: Montreal, Winnipeg.

New 200 Page Green Book 1904 EDITION.

"Saw and Knife Fitting Machinery and Tools"

MAILED FREE ON REQUEST.

A Book for Mill and Factory Managers, Superintendents, Foremen and Saw Filers.

BALDWIN, TUTTILL & BOLTON,
GRAND RAPIDS, MICH., U.S.A.



B. T. & B Full Automatic Knife Grinder. Style D

SAW AND KNIFE FITTING THE NEW B. T. & B. MANUAL

Revised edition. 144 pages. Copiously illustrated and Durably Bound. Is an exhaustive treatise on the care of Saws and Knives.

A Practical Book for Saw Filers.

Mailed Postpaid on Receipt of Price

\$2.00

THE "B. T. & B." LINE

NEED ANYTHING ?

- Sharpeners, Swages,
- Stretchers, Shapers,
- Side Files, Shears,
- Retoothers, Brazing Machines, Filing Clamps, Lap Grinders, Lap Cutters, Patch Machines, Crack Drills, Hammering Benches, Bench Grinders, Band Filers, Band Setters, Pulleys and Stands, Brazing Forges, Saw Sets, Saw Gauges, Swage Bars, Upsets, Straight Edges, Tension Gauges, Back Gauges, Leveling Blocks, Anvils, Hammers, Speed Indicators, Emery Dressers, Knife Grinders, Knife Balances, Shingle Saw Grinders, Burr Gummers, Post Brackets, Stretcher Bench Brackets, Cutters, Marking Stamps, Saw Guides, etc.

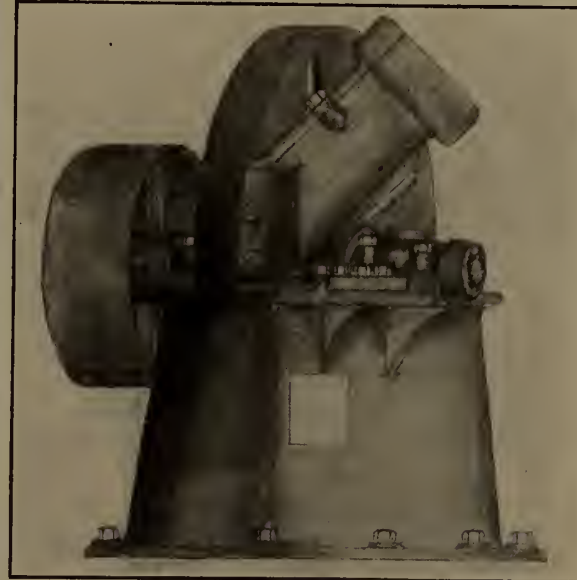

Pat'd. Apr. 23, 1901.

Made in larger sizes for chipping pulp wood & large saw mill refuse

40 IN. IMPROVED "HOG"

For cutting Lath Mill, Planing Mill and Box Factory Refuse into fuel chips, no matter whether wet or dry. Will feed stuff through at the rate of 40 ft. per minute. Takes less power to drive than any other Hog made. A 6" belt drives it. Has but three knives to be taken care of.

For prices and further information, address

I. N. KENDALL, 203 Bridge St., OTTAWA, ONT.

PORTABLE SAW MILLS

IN MANY INSTANCES ARE INDISPENSABLE

OUR EXPERIENCE IN BUILDING THEM EXTENDS OVER HALF A CENTURY

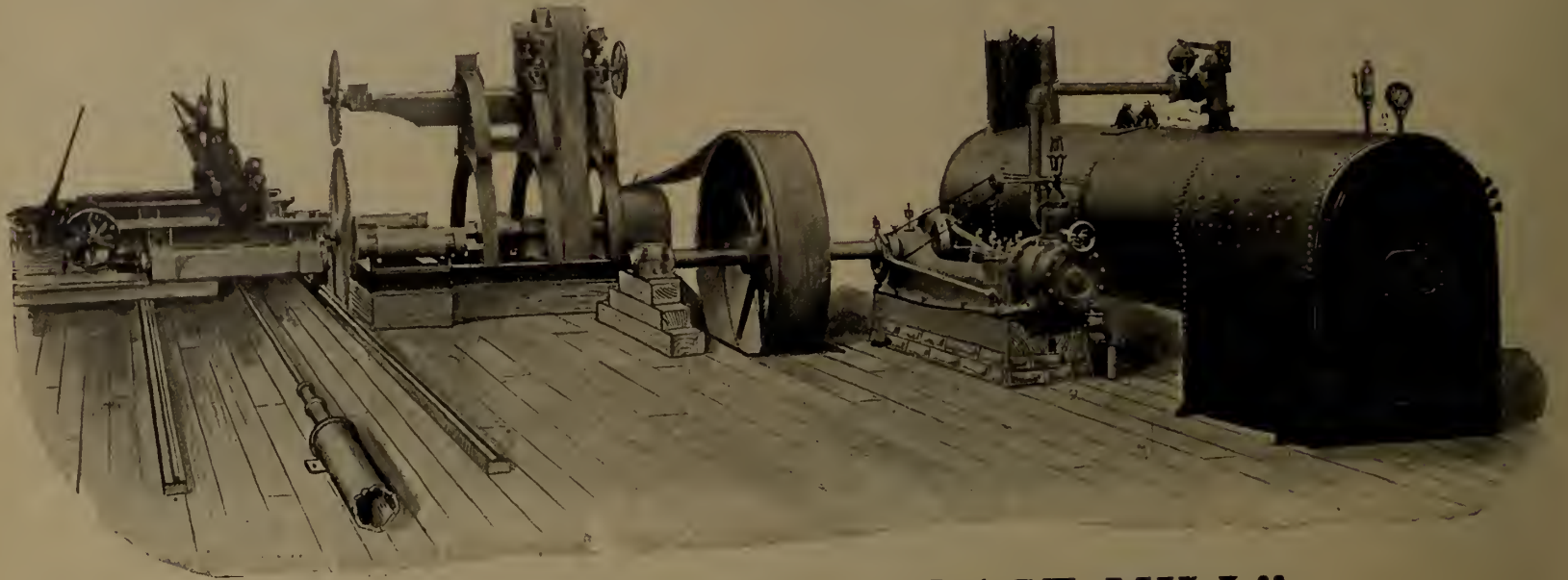

100 H. P. "PACIFIC COAST MILL"

With No. 4 Saw Frame, 72 in. Lower and 56 in. Upper Saw; No. 6 Girder Steel Unbreakable Carriage, opening 72 inches from Saw—all portions of Carriage either Rolled or Cast Steel, Direct-Acting Steam Feed, etc.

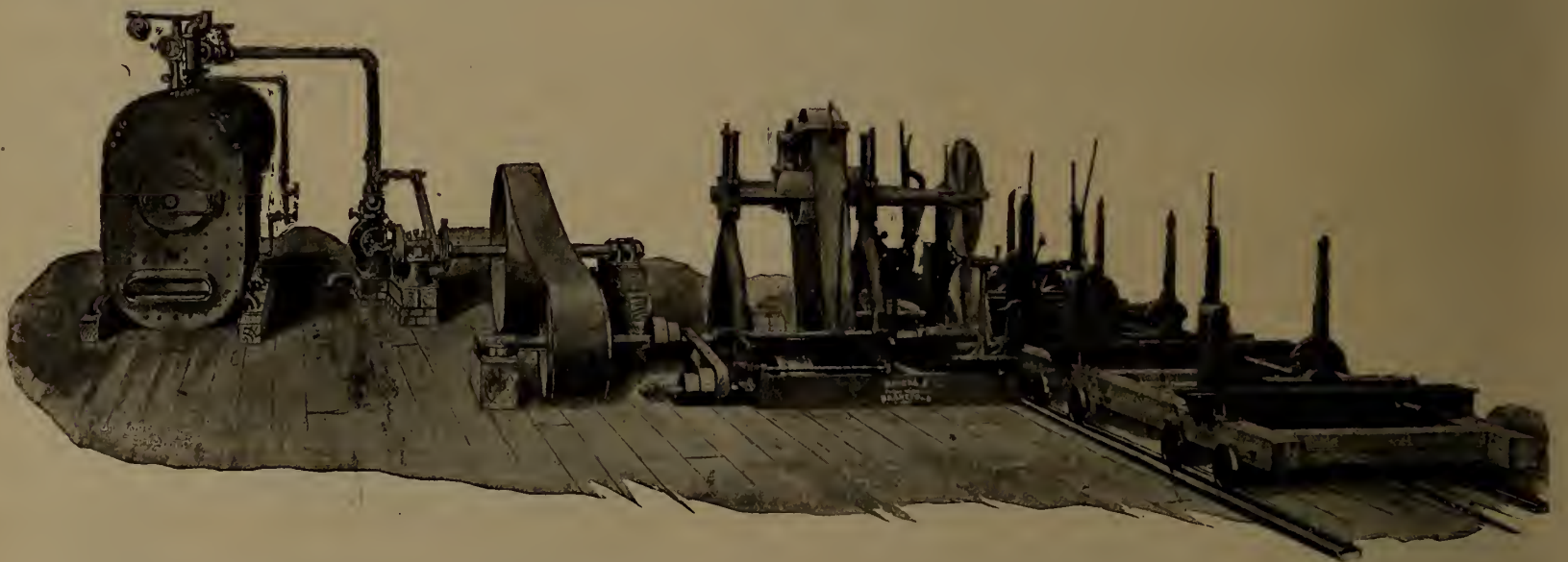

60 H. P. "ONTARIO AND WESTERN MILL"

With No. 3 Saw Frame, having 12 inch face Friction Feed Works, taking 60 inch Lower Saw and 40 inch Upper Saw. A No. 3½ 5 Block Girder Steel Carriage opening 50 inches from Saw, with Peel and Reliance Cant Hook Double Spud Dogs—Rope Feed, Automatic Coupling in Carriage between 3rd and 4th blocks—extras when required Bull Wheel, Slab Saw, Single or Double Edger, Trimmer, Live Rolls, Planer and Matcher.

The above are our Large Portable Saw Mills.

We manufacture all sizes down to 12 H. P., with Saw Irons of Smallest and Lightest Dimensions.

WRITE US FOR PRICES AND CATALOGS

AGENCIES:

WATEROUS ENGINE WORKS CO.
H. B. GILMOUR,

WINNIPEG, MAN.
VANCOUVER, B. C.

WATEROUS, Brantford, Canada

NATURAL DRAFT MOIST AIR . . . **DRY KILNS**

LUMBER TRUCKS and TRANSFER CARS

Write for prices and particulars of the most simple and efficient Natural Draft Dryer on the market. Testimonials and list of users sent on application. Every square inch of heating surface is utilized to the uttermost and perfect ventilation and circulation is obtained by a very simple arrangement of ducts. Write for particulars to

SHELDON & SHELDON,
GALT, ONT.

FORMERLY McEACHREN HEATING & VENTILATING CO.

The Morton Lumber Drier

Stands for

Three Comforts

Quality Efficiency Price



Kilns That Dry Your Lumber
Without Drying Up Your Bank Account
Write for Catalogue C to-day

The A. H. Andrews Co.

174-176 Wabash Avenue - - CHICAGO, U.S.A
Eby Machinery Co., San Francisco, Pacific Coast Agents
H. G. Boardman, 1170 Broadway, N. Y., Eastern Sales Agent

3 Vital and Exclusive Features of Merit

There is one dry kiln whose equipment stands head and shoulders above that of all others in three important features. That's

THE STANDARD DRY KILN



Its exclusive points of superiority are—

(1) THE STANDARD GRADUATED STEEL POST FOUNDATION, which does away with the costly nuisance of building walls, or piers, ON A SLANT. The steel posts are graduated in height to provide an incline to the tracks.

(2) THE HUSSEY PATENT DRY KILN "DOOR CARRIER." Guaranteed to end all dry kiln troubles. With it one man or boy can open or close the biggest, heaviest kiln door in 10 seconds.

(3) THE STANDARD CHANNEL STEEL, ROLLER DRY KILN TRUCKS—the easiest, lightest running, most durable trucks you ever used. They have MALLEABLE IRON WHEELS.

Write for our Catalogue "D," for complete information about the Standard Kiln.

The Standard Dry Kiln Co.

Indianapolis, Indiana

SAW MILL OPERATORS are finding that

"MIDLAND" BEARING METAL

is all that **WE CLAIM FOR IT**

and then it is sold for only

15 CENTS A POUND

You will be pleased if you will give us a trial order.

GEORGIAN BAY ENGINEERING WORKS

Midland, Ontario



FOR

DRY KILNS

that will season lumber of all kinds and under all conditions, whether partially air-seasoned or green from the log, in shortest time and at least cost, entirely free from checking warping or case hardening,

Write to—

McEACHREN HEATING & VENTILATING COMPANY, GALT, CANADA

HUTHER BROS. PATENT GROOVER OR DADO HEAD
For cutting any width groove from 1/4-inch to 2 inches or over

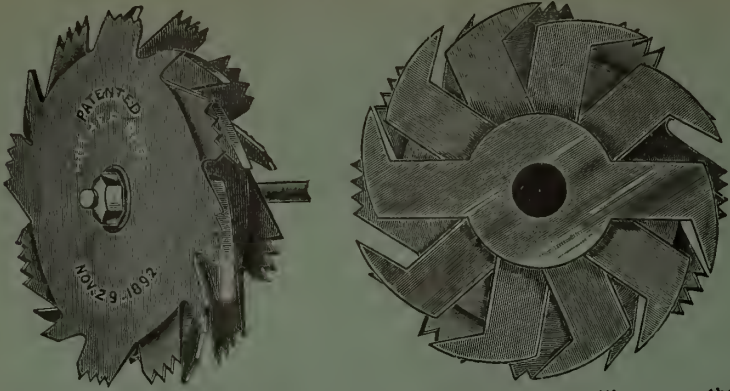

Can be used on any Circular Saw Mandrel. Will cut a perfect groove with or across the grain. This is the only Dado Head on the market that gives entire satisfaction on all classes of work. No screw adjustment. For different width grooves, simply remove or add inside cutters. Sold by builders and dealers of woodworking machinery in all parts of the United States. Will send on approval, in competition with any other make on the market; if not the best return at our expense. HUTHER BROS., Platt Street, ROCHESTER, N.Y., manufacturers of Circular Saws, Morgan Pattern Lock-Corner Box Cutters, Concave Saws, etc.

Steam, Power
and
Centrifugal Pumps,
Condensers,
Travelling Cranes.



Stock Carried in:
HALIFAX,
MONTREAL,
HAMILTON,
WINNIPEG,
VANCOUVER.

THE SMART-TURNER MACHINE CO., LIMITED
HAMILTON, ONTARIO

Galt Machine Knife Works



MACHINE KNIVES OF EVERY DESCRIPTION
FOR **Woodworking Machines**
... Send for Price List ...
The Peter Hay Knife Co., Limited - Galt, Ont.

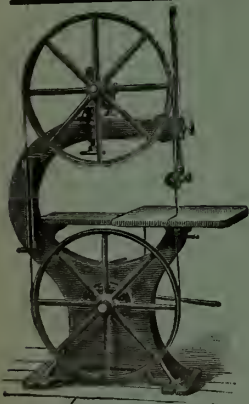

CRESCENT MACHINERY

Quality is all right.
So's the price.

- Band Saws
- Jointers
- Saw Tables

Very low price on
BAND SAW BLADES
Catalogue tells the rest.

H. W. PETRIE
Dept. C. M.
TORONTO, ONT.



RIGE LEWIS & SON,

Limited

S
A
W
S

Chain
Bolts
Files

Steel
Iron
Horse Shoes

A
X
E
S

Peaveys
Pike Poles
Cant Hooks

Boot Calks
Lumber Leads
Timber Grips

R
O
P
E

TORONTO.

Write for Prices

THE
**LEATHER
BELT**
THAT'S
KNOWN
OUR
"EXTRA"



MONTREAL
WINNIPEG

TORONTO
VANCOUVER

PINK LUMBERING TOOLS

The Standard Tools

In Every Province of the Dominion, * * * * *
* * * * * New Zealand, Australia, Etc.



Pink Round Bill Peavey, Handles in Split Maple

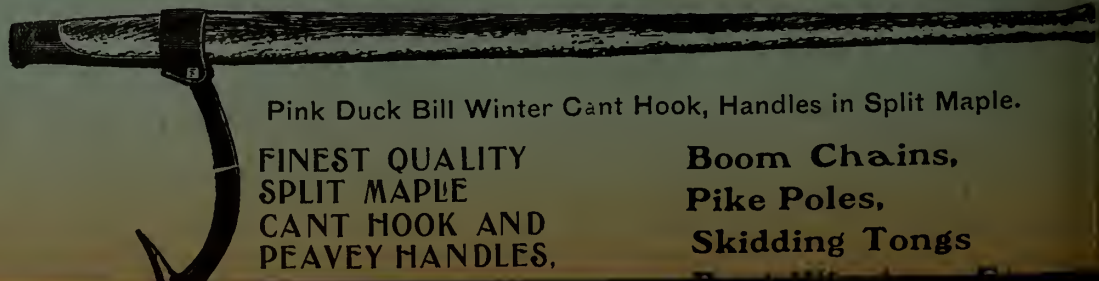

Pink Duck Bill Winter Cant Hook, Handles in Split Maple.

**FINEST QUALITY
SPLIT MAPLE
CANT HOOK AND
PEAVEY HANDLES,**

**Boom Chains,
Pike Poles,
Skidding Tongs**

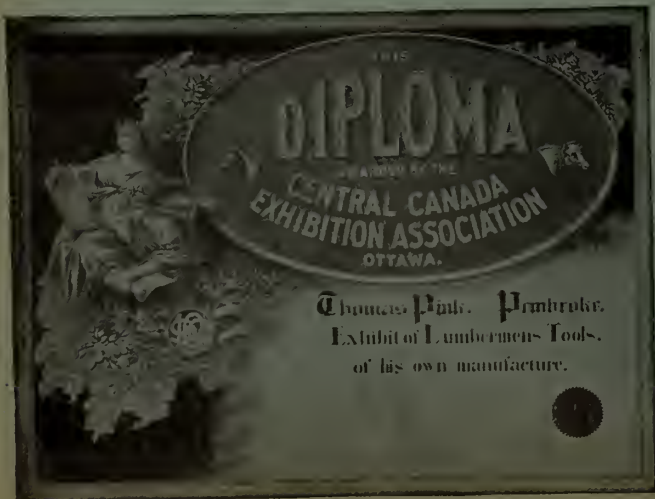

Thomas Pink, Pembroke,
Exhibit of Lumbermen's Tools,
of his own manufacture.

THOMAS PINK
Pembroke, Ont.

THE CANADA LUMBERMAN AND WOOD-WORKER

REACHES REGULARLY THE MANUFACTURERS AND BUYERS AND SELLERS OF TIMBER PRODUCTS IN EVERY PART OF CANADA AND LEADING IMPORTERS ABROAD

VOLUME XXV. }
NUMBER 6.

TORONTO, MONTREAL — JUNE, 1905 — WINNIPEG, VANCOUVER

{ TERMS, \$1.00 PER YEAR
Single Copies, 10 Cents.

LUMBERMEN'S LOG STAMPS
STEEL & RUBBER STAMPS, BRASS STENCILS, ETC.
THE SUPERIOR MFG. CO.
COR. BAY & ADELAIDE STS. TORONTO, CAN.
Write for Catalogue.

JNO. S. FIELDING, C. E.
WATER POWERS AND DAMS
Room 2, 15 Toronto Street - TORONTO

PERFORATED SHEET METALS

IN
BRASS, COPPER, STEEL, ETC.

All sizes of Perforations and Thickness of Metals for Miners' use.
Grain Cleaning Machinery. Bee Keepers. Malt Kiln Floors, Etc.

The **B. GREENING WIRE CO., Limited**
HAMILTON, ONT. MONTREAL, QUE.



The Ottawa Saw Co. LIMITED
Middle Street, OTTAWA, ONT.
Sandvik Swedish Steel
Band, Gang and Circular Saws
P. M. FEENY, Manager.

LEATHER BELTING

It isn't the price, it's what you get for the price, that counts.

J. L. GOODHUE & CO.,
DANVILLE, QUEBEC.

D. K. McLaren
GENUINE
Oak Belting
MILL SUPPLIES

751 Craig St., Montreal,
196 King Street West

WOODS LIMITED

.. Wholesale Manufacturers of ..

LUMBERMEN'S AND CONTRACTORS' SUPPLIES

INCLUDING

Tents, Flags, Awnings, Tarpaulins, Clothing,
Overalls, Shirts, Mitts, Underwear, Blankets,
Axes, Moccasins, Woods Celebrated Eider
Down Sleeping Bags

WOODS BUILDING - OTTAWA, CAN.

SEND FOR **H. W. PETRIE'S**
MONTHLY STOCK LIST
NEW & 2ND MACHINERY
TORONTO, CANADA

DICK'S BELTINGS



Never is affected by wetness, and does not stretch

Excels in Transmission Power

Always Uniform.

LARGE STOCK ON HAND

WRITE TO SOLE AGENTS:
J. S. YOUNG, 14 Hospital Street MONTREAL

.. NOTICE ..

We have had a large quantity of SECOND HAND PLANT placed in our hands for sale, including Engines, Boilers, Pumps, Hoists, Derricks, Cableways, Light Rails, 1 Sawing and Planing Outfit, 1 Paint Sprayer, 1 Light Locomotive, Etc., Etc.

Write for Particulars

W. H. C. MUSSEN & CO.

MONTREAL, QUE.

THE E. R. BURNS SAW CO.
TORONTO, ONT.

MANUFACTURERS OF HIGH-GRADE

Circular and Long Saws
UNEXCELLED

SHINGLE SAWS

OUR INSERTED TOOTH SAWS POSITIVELY THE BEST



The Wm. Hamilton Mfg. Co., Limited

Builders of a Complete Line of

SAW MILL MACHINERY

We are specialists in the building of sawmill machinery—we have been making it, and making it well, for nearly fifty years.

Surely our machines must have merit—must have lived up to all our claims, or we would not be in business to-day.

Back of every machine we sell is our guarantee against its failure due to defective material or workmanship, and our warranty of its successful operation.

All our machines are of simple design and enduring construction.

—

We are specially well equipped for handling repair jobs, and can give your orders prompt attention.

—

Can we not send you our catalogues?
Write Department L for them.

Our Line Includes

Engines and Boilers
 Band Mills
 With Weight or Steam Tension
 Gangs
 Carriages
 Husk Frames
 Log Handling Machinery
 Edgers
 Trimmers and Slashers
 Steam, Hand and
 Power Set Works
 Lath Mill, Shingle Mill
 and Filing Room Machinery
 Twin Circulars
 Tie Mills
 Burners

Head Office and Works: **PETERBOROUGH, ONTARIO**

SOME POINTERS for PROGRESSIVE MILL OWNERS

1. The Allis-Chalmers Horizontal Band Re-Saw Mill can be handled with less attention than the upright machines.
2. If you want a valve for steam feeds that will not "kick" get the New Allis Vertical.
3. The No. 2 Heavy Timber Edger is built in 5 sizes having lumber spaces respectively of 48, 54, 60, 66 and 72 inches.
4. The 6-Foot Band Mill will carry saws from 8 to 9 in. wide ; the shortest saw 31 ft., 6 in. long cuts boards 25 in. wide ; the longest saw 34 ft. cuts boards 40 in. wide.
5. The Bullock Electric Lighting Plants give best satisfaction.

Allis-Chalmers-Bullock Limited

WORKS : MONTREAL.

BRANCH OFFICES : HALIFAX, TORONTO, WINNIPEG, NELSON, VANCOUVER

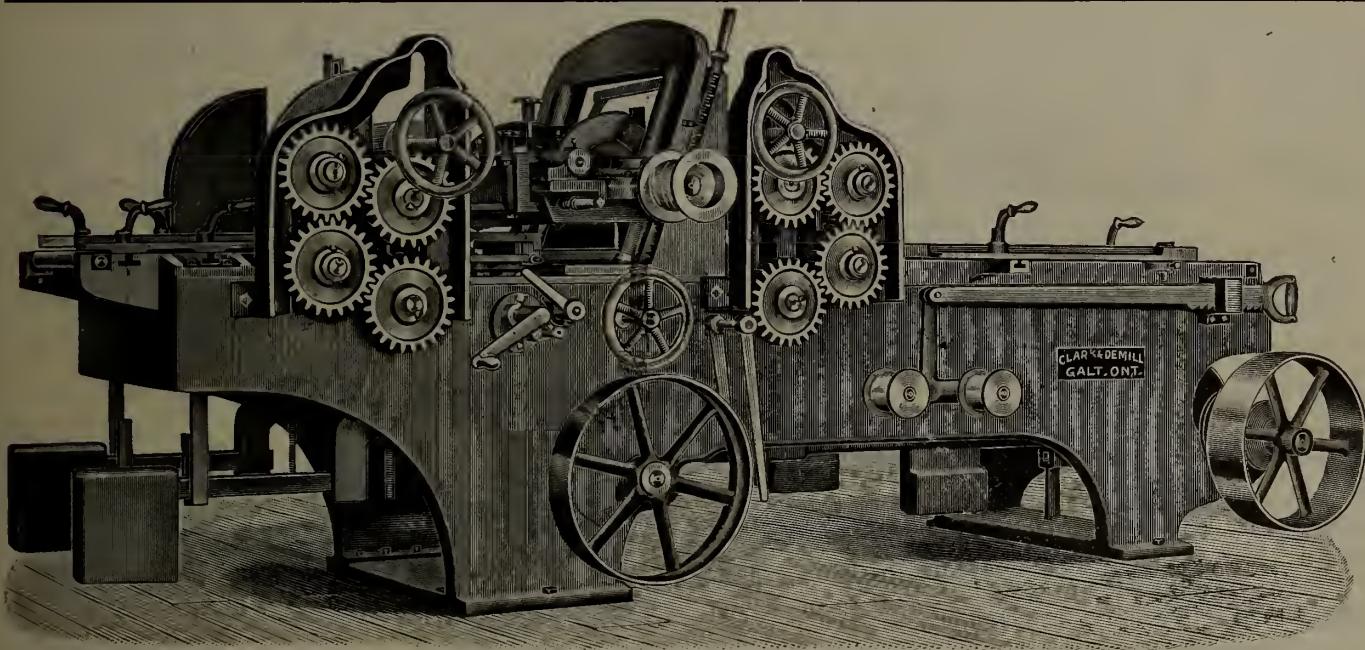

Our No. 72 LIGHTNING PLANER AND MATCHER

Kindly note that we make this machine in different sizes, single or double cylinder, as desired. Parties desiring thoroughly up-to-date machinery will find it to their advantage to write us before placing their order.

Write for new Catalogue.

Clark-Demill Co.

Limited

Hespeler, Ont.



How About Wood Split Pulleys ?

When making your spring alterations in your mill you will doubtless require some Wood Split Pulleys. If you want to get the best wood split pulley manufactured to-day make your order read—

FAIRBANKS WOOD SPLIT PULLEYS

Study the cut. The web construction built in the rim not only strengthens the entire pulley but makes it impossible for the rim to work loose at the arm. Each segment is glued and nailed with three coated nails to the next one. Four point bushings are used, giving twice as much grip on the shaft as in the usual two point bushings. Write us.

THE CANADIAN FAIRBANKS COMPANY, LIMITED

MONTREAL

TORONTO

VANCOUVER

WINNIPEG

BRITISH COLUMBIA LUMBER AND SHINGLE MANUFACTURERS

The Canadian Pacific Lumber Co., Limited
PORT MOODY, B. C.

Manufacturers and Wholesale Dealers in All Kinds of **B. C. LUMBER, LATH, MOULDINGS, ETC.**

The Largest Shed and Dry Kiln Capacity of any Mill in British Columbia. Special Attention Given to Orders from Manitoba and the Territories. † Long Distance Telephone Connection. † Address the Company at Port Moody or **BYRNES & CUDDY, Selling Agents, WINNIPEG**

CLOVERDALE MILLING CO., CLOVERDALE, B. C.

== Red Cedar Shingles ==

OUR SPECIALTY

SECOND TO NONE

CORRESPONDENCE SOLICITED

PETER LUND, Managing Director.

J. BRCKENRIDGE, President.

MANUFACTURERS OF ALL KINDS OF

Grows Nest Pass Lumber Co., Limited
WARDNER, B. C.



BUILDING MATERIAL

Capacity 150,000 Feet Per Day.

THE KING LUMBER MILLS, LIMITED, CRANBROOK, B. C.

Manufacturers of

Building Materials

And All Kinds of DIMENSIONS, FLOORING, CEILING and BASE and CASE MOULDINGS

Columbia River Lumber Company, Limited

HEAD OFFICE AT GOLDEN, B. C.

Largest Capacity in Mountains

MILLS AT { GOLDEN, B. C.
BEAVER, B. C.
KAULT, B. C.
CARLIN, B. C.

ROUGH AND DRESSED

MANUFACTURERS OF ALL KINDS OF

LUMBER

FIR, SPRUCE
CEDAR AND PINE

LATH

Telephone Poles, Piling, Etc., a Specialty.

The Fernie Lumber Co., Limited, Fernie, B. C.

MANUFACTURERS OF AND DEALERS IN ALL KINDS OF

ROUGH AND DRESSED LUMBER

Dimension and Bridge Timber a Specialty.

Moulding in Stock or Made to Order.

JOS. GENELLE, Manager.

J. G. BILLINGS, Secretary.

THE YALE-COLUMBIA LUMBER COMPANY, LIMITED

Head Office: NAKUSP, B. C.

Mills at Nakusp, Westley and Cascade, B. C.

MANUFACTURERS OF

DEALERS IN

All Kinds Rough and Dressed Lumber, Mouldings, Lath, Etc.

Cedar and Fir Piles, Telephone and Telegraph Poles, Fence Posts, Etc.

North Star Lumber Co., Limited, Cranbrook, B. C.

Manufacturers of

PINE, FIR and TAMARAC LUMBER

Specialty: Heavy Timber and Piling

BRITISH COLUMBIA LUMBER AND SHINGLE MANUFACTURERS

D. & J. HADDEN, CLOVERDALE, B.C.

MANUFACTURERS AND DEALERS IN THE HIGHEST GRADE

LUMBER AND RED CEDAR SHINGLES

Send your orders to the above firm, who can supply you with shingles that cannot be beaten for quality and prices.

Agent for Ontario : Woodstock Lumber and Manufacturing Co., Woodstock, Ont.



THE PIGEON RIVER LUMBER COMPANY PORT ARTHUR, ONT

MANUFACTURERS OF

Band Sawed White Pine Lumber, Lath, Pine and Cedar Shingles,

are operating their extensive plant night and day, to keep abreast with orders.

THERE IS A BECAUSE—
A trial order will tell you why.

Winnipeg Representative,
D. J. McDONALD, Clarendon Hotel.

J. A. SAYWARD

MANUFACTURER OF AND DEALER IN

Cedar and Spruce Lumber

Shingles, Lath, Spars, Etc.

ORDERS CAREFULLY EXECUTED
PROMPT SHIPMENTS

VICTORIA, B. C.

THE BRITISH COLUMBIA MILLS, TIMBER & TRADING COMPANY

Head Office : VANCOUVER, B. C.

Winnipeg Office : Merchants Bank Building P. O. Box 235

MANUFACTURERS OF

BRITISH COLUMBIA FIR, CEDAR and SPRUCE—both Rough and Dressed. Sash, Doors, Mouldings. Lath and the Highest Grades

“ROYAL CITY BRAND”

RED CEDAR SHINGLES

DOUGLAS FIR TIMBER

All Widths and Thicknesses up to 120 feet in Length Supplied on the Shortest Possible Notice.

HASTINGS SAW MILL - VANCOUVER, B. C.
ROYAL CITY SAW MILL, VANCOUVER, B. C.

ROYAL CITY SAW MILL, NEW WESTMINSTER, B. C.
MOODYVILLE SAW MILL - BURRARD INLET, B. C.

Total Capacity, 400,000 Feet of Sawn Lumber per Working Day of Ten Hours.

The Ladysmith Lumber Co., Limited

LADYSMITH, B. C

Manufacturers of

LUMBER, LATH, SHINGLES,
MOULDINGS, ETC.

SPECIALTY : The best Cedar Shingles manufactured on the Coast.

FRESH WATER FIR LATH ALWAYS IN STOCK.

Capacity of Shingle Mill, 100,000 per day of 10 hours.

Correspondence Solicited

BRITISH COLUMBIA LUMBER AND SHINGLE MANUFACTURERS

Mouldings

Shingles

VICTORIA LUMBER AND MANUFACTURING CO., LIMITED

MILLS AT CHEMAINUS, B. C.

FIR AND GEDAR LUMBER

of all descriptions, in straight or mixed cars.

We can supply large and long timbers, but don't care to ship anything over 40x40x140 feet long.

Prompt Shipments Good Quality and Manufacture Long Lived Timber

ADDRESS—

CHEMAINUS, B. C.

D. B. GRANT.

T. W. KERR

DELTA SAW MILL CO.

MANUFACTURERS OF

Rough & Dressed Lumber, Lath, Shingles, Fence Pickets, Doors, Sash, Mouldings, Salmon and Fruit Boxes, and Round Tanks

Correspondence Solicited. LADNER, B. C.

CEDAR LUMBER

Manufacturers and Shippers

Cedar, White Pine, Fir Lumber, Lath, Mouldings, Shingles

Bowman Lumber Co., Ltd. Revelstoke, B. C.

Mills at REVELSTOKE, B. C. COMAPLIX, B. C.



ROSS BROS. & CO.

FORMERLY OF WHITEMOUTH, MAN.

SUCCESSORS TO THE ELKMOUTH LUMBER CO. ELKMOUTH, BRITISH COLUMBIA

Full Lines Kept in

Pine, Fir and B. C. Tamarac

ORDERS RESPECTFULLY SOLICITED

Send for Our Prices

The East Kootenay Lumber Co., Limited

Saw and Planing Mills at Ryan, Cranbrook and Jaffray, B. C.

Capacity, 150,000 Feet Per Day

MANUFACTURING

LARCH PINE and FIR

Lumber, Timber, and all kinds of Mouldings, also dealers in Railway Ties, Piles and Poles

Large Stocks of Well Seasoned Dry Material Always on Hand

Head Office: CRANBROOK, B. C.

TENTS, OIL CLOTHING, and TARPAULINS, HORSE and WAGON COVERS FOR LUMBERMEN'S USE A SPECIALTY.

EVERYTHING IN CANVAS MANUFACTURED.

The Montreal Tent, Awning and Tarpaulin Company, 25 Youville Place, MONTREAL

Scribner's Lumber and Log Book

A handy book for Lumbermen. Gives Correct Measurements of Scantlings, Boards and Planks; Cubical Contents of Square and Round Timber; Doyle's Rules, and much other practical information.

ADDRESS

Price 35 Cents THE CANADA LUMBERMAN, Toronto, Ont.

Moreau's Pulpwood Barking Machine

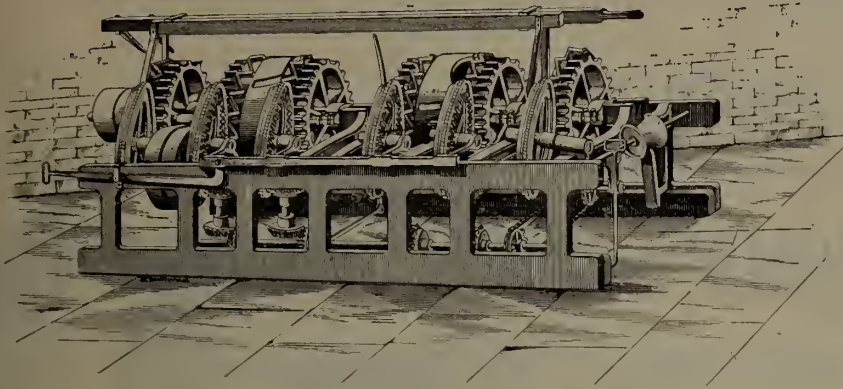

WEIGHT 4,200 LBS.

Latest and best Pulpwood Barking Machine. Requires about 7 h. p. to drive it full speed in work and one man can handle it and bark 22 to 30 cords of 4 foot wood per day according to average size of wood.

Wood is fed end on and any size from 3 to 24 inches, as the wood runs without loss of time between sticks. No long shavings and greatest economy in wood. Machines may be seen working any time. Write me for particulars.

R. S. P. SMYTH - QUEBEC, QUE.

Sole Agent for Canada

*P. O. Box 236
L. D. Phone 386*

THE E. LONG MANUFACTURING CO., ORILLIA, ONT.

THESE SAW CARRIAGES ARE MADE OF CAST STEEL, AND OPEN 36 TO 54 IN. FROM SAW.

We build Double Edgers, Steam Feeds, Log Jacks, Live Rolls, Trimmers, Slab Slashers, Steam Niggers.

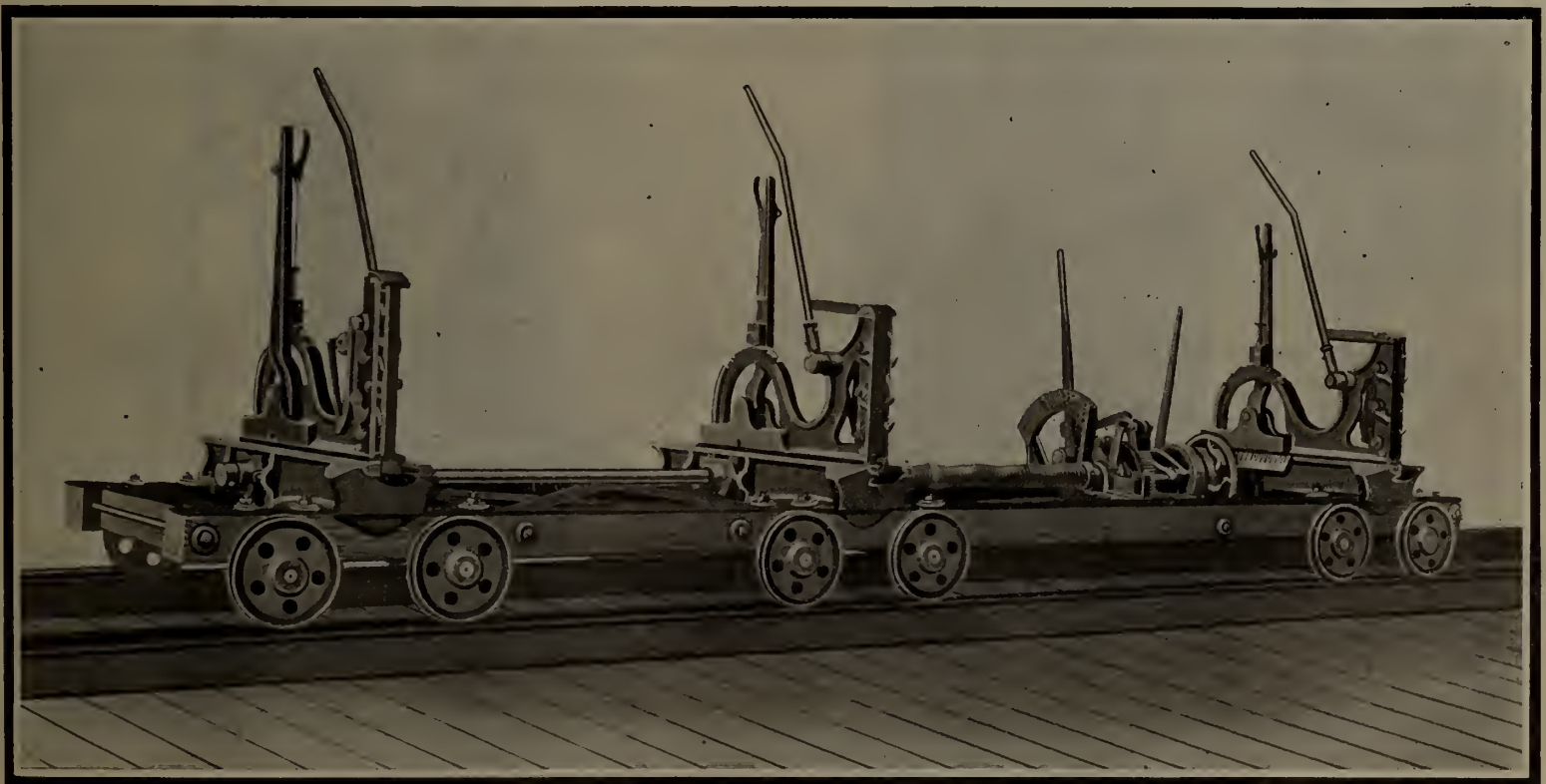

COMPLETE LINE OF SAW AND SHINGLE MILL MACHINERY
WRITE FOR CATALOGUE AND PRICES

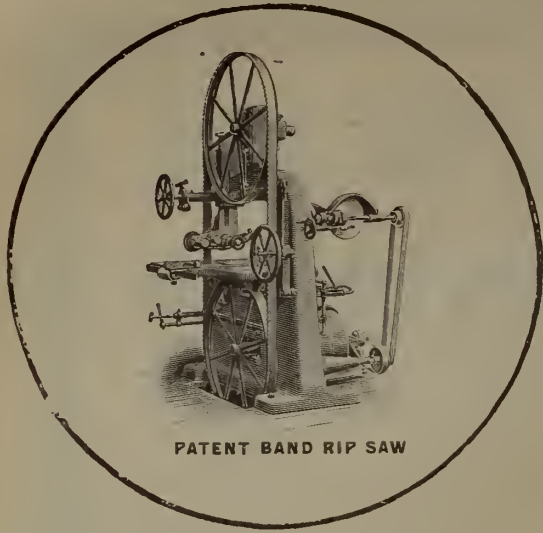

PATENT BAND RIP SAW

"DEFIANCE" Wood--Working Machinery

For Manufacturing
HUBS, SPOKES, WHEELS, WAGONS,
CARRIAGES, RIMS, SHAFTS, POLES,
NECK-YOKES, SINGLETREES, BARREL
HOOPS.

Handles of Every Kind, insulated Pins, Spools,
Bobbins, Oval Wood Dishes, and General Wood-
Work.

Invented and Built by

THE DEFIANCE MACHINE WORKS,
Defiance, Ohio, U. S. A.



26" DOUBLE SURFACE PLANER



The "Alligator" Steam Warping Tugs

SIDE WHEELS OR TWIN SCREWS

The Twin Screws are arranged with flexible joint to
raise up in crossing portage

MANUFACTURED BY

WEST & PEACHEY, - Simcoe, Ont.

Cables carried in stock for renewals

Pure Manila Rope

HIGHEST QUALITY MADE

British Manila

Sisal Rope

PURE SISAL

Lath Yarn

Wire, Write or Phone

Canadian Cordage
& Manufacturing
Company, Limited

Toronto, Ontario, Canada

Long Distance Phone 162.

Our Rope and Lath Yarn are Recogniz-
ed as the Best on the Market.



Cowan & Co. of Galt, Limited

GALT, CANADA

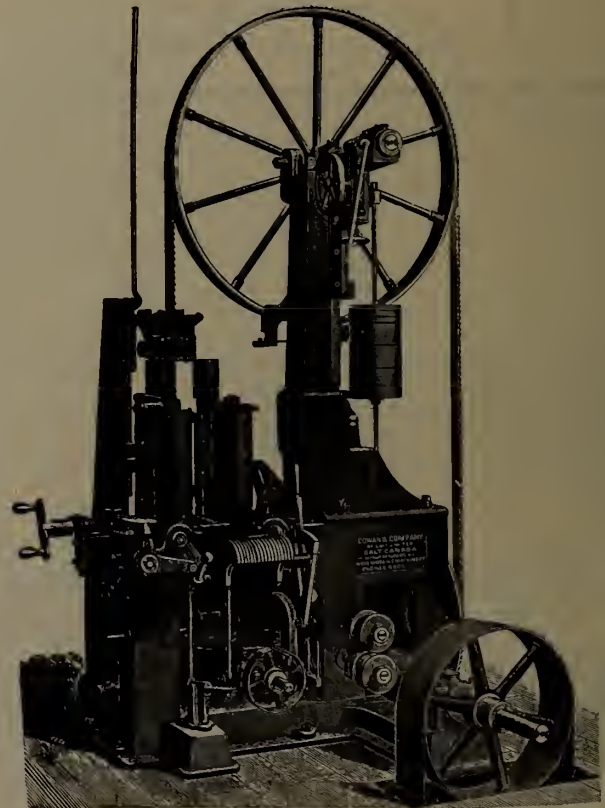

No. O Band R Saw, M167

We build this machine in different styles and sizes, with wheels 42", 48", 54"
and 60" diameter. Also a full line of the most up-to-date Wood Working Machinery
of superior material and workmanship.

Write for cuts and prices.

We are the largest exclusive manufacturers of Wood-Working Machinery in Canada.

R. H. SMITH CO., LIMITED

— St. Catharines, Ont. —

We are the Sole Manufacturers of Saws
under the

Simond's Process

in the Dominion of Canada.

There is no process its equal for tempering circular saws. Other makers recognize this fact, as some of them, in order to sell their goods, claim to have the same process. All such Claims are FALSE, as the patentee in the U. S. and ourselves are the only firms in the world who use it.



INSERTED TOOTH SAWS

Notice the improved shank. We call particular attention to the swell which strengthens it at the weakest part and which gives it more wear than the old style.

Shanks made in usual gauges and to fit your saws perfectly.

SHINGLE SAWS

The quality of the "Simonds" Shingle Saws is proven by the fact that the largest shingle and machine manufacturers in Canada are using them.

Run a "Simonds" and you will increase your output.



CROSS-CUT SAWS

THE "NARROW LEADER"
REFINED SILVER STEEL.

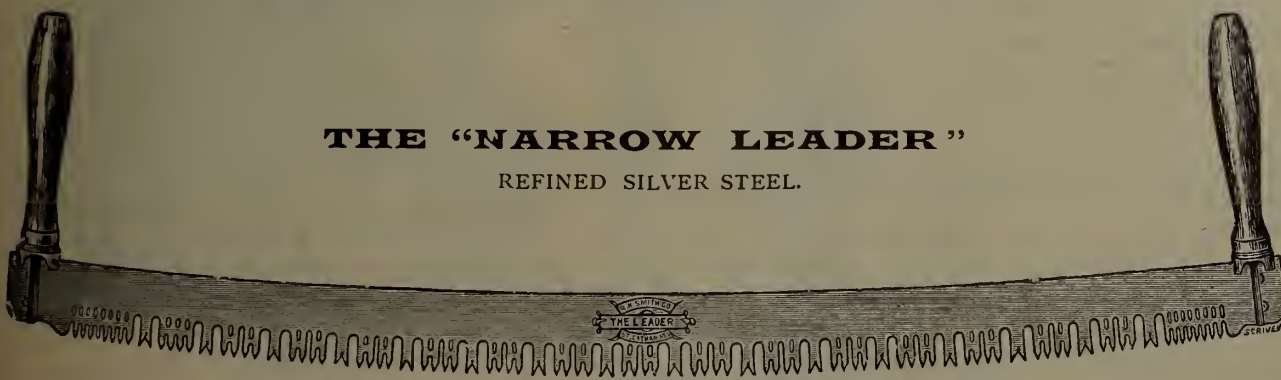

The Simond's temper and style of tooth make the "Leader" the fastest and easiest cutting saw manufactured.

Write for prices.

R. H. SMITH CO., Limited, St. Catharines, Ont.

CASSIFIED INDEX OF ADVERTISERS

AXES
 Dundas Axe Works..... 30

ALLIGATOR TUGS
 West & Peachey..... 8

BELTING
 Canadian Fairbanks Co..... 3
 Dominion Belting Co..... 34
 Gutta Percha & Rubber Mfg. Co..... 41
 Goodhue & Co., J. L..... 1
 McLaren, D. K..... 1
 McLaren Belting Co., J. C..... 44
 Waterous Engine Works Co..... 34
 Wilby, P. H..... 12
 Young, J. S..... 1

BABBITT METALS
 Syracuse Smelting Works..... 35

BOILERS
 Canada Foundry Co., Limited..... 12
 Dymont Foundry Co..... 36
 John McDougall Caledonian Iron Works 30

DOORS
 New Century Refrigerator & Mfg. Co. 10

DRY KILNS
 Andrews Co., The A. H..... 43
 McEachren Heating & Ventilating Co. 43
 Sheldon & Sheldon..... 43
 Standard Dry Kiln Co..... 43

ELEVATING AND TRANSMITTING MACHINERY
 Dodge Manufacturing Co..... 11
 Perrin & Co., R..... 12

EMERY WHEELS
 Hart Corundum Wheel Co., Limited.. 28

ENGINES AND LOCOMOTIVES
 Dymont Foundry Co..... 36
 Gartshore, John J..... 10
 Owen Sound Iron Works..... 41
 Robb Engineering Co..... 32

EDGERS
 Gordon Hollow Blast Grate Co..... 35

GRATES
 Gordon Hollow Blast Grate Co..... 35

LUMBERMEN'S SUPPLIES
 Beal Leather Co., R. M..... 39
 Capstan Mfg. Co..... 22
 Johnson, A. H..... 35
 Montreal Tent, Awning & Tarpaulin Co..... 7
 Park, Blackwell Co..... 39
 Rice Lewis & Sons, Limited..... 44
 Thompson Mfg. Co..... 32
 Woods, Limited..... 1

LUMBER AND SHINGLE MANUFACTURERS
 B. C. Mills, Timber & Trading Co... 5
 Bowman Lumber Co..... 6
 Cook & Bro. Lumber Co..... 34
 Canadian Pacific Lumber Co..... 4
 Cloverdale Milling Co..... 4
 Crows Nest Pass Lumber Co..... 4
 Columbia River Lumber Co..... 4
 Delta Saw Mill Co..... 6
 East Kootenay Lumber Co..... 6
 Fernie Lumber Co..... 4
 Hadden, D. & J..... 5
 King Lumber Mills..... 4
 Ladysmith Lumber Co..... 5
 North Star Lumber Co..... 4
 Pigeon River Lumber Co..... 5
 Ross Bros. & Co..... 6
 Sayward, J. A..... 5
 Victoria Lumber & Mfg. Co..... 6
 Yale-Columbia Lumber Co..... 4

LUMBERMEN'S TOOLS
 Baldwin, Tuthill & Bolton..... 41
 Burton Saw Co., A. J..... 39
 Hay Knife Co., Peter..... 44
 Pink, Thomas..... 44

MISCELLANEOUS
 Alexander Engraving Co..... 34
 Bradstreets..... 10
 Canadian Office & School Furniture Co. 10
 Denton, Dunn & Boulton, Barristers. 34
 Fielding, J. S., Consulting Engineer.. 1
 Glenyards Fire Clay Co..... 37
 Georgian Bay Engineering Works—
 Grinders..... 51
 Huther Bros.—Dado Heads..... 44
 Lumber Mutual Fire Insurance Co.... 33
 Midland Engine Works Co.—Tram
 Car Wheels..... 12

Manitoba Gypsum Co.—Plaster..... 35
 Spence & Co., R.—Files and Rasps.. 11
 Sessenwein Bros.—Rails..... 29
 Toledo Fire Insurance Co..... 31
 Vogel, C. H.—Pulp Mill Engineer.... 27

OILS.
 Commercial Oil Co..... 34
 Canadian Oil Co..... 22
 Queen City Oil Co..... 11

PROVISIONS
 Eckardt & Co., H.P..... 27

PORTABLE SAW MILLS
 Drake, F. J..... 36
 Owen Sound Iron Works..... 41

PLANERS AND MATCHERS
 Clark & Demill..... 3

PULLEYS
 Canadian Fairbanks Co..... 3

PACKING AND PIPE COVERING
 Garlock Packing Co..... 12
 Purvis Co., E. L..... 37

ROPE
 Canadian Cordage Co..... 8
 Consumers Cordage Co..... 33
 Dominion Wire Rope Co..... 12
 Greening Wire Co., B..... 1
 Mussen & Co., W. H. C..... 1

ROOFING
 Bird & Son, F. W..... 32

RE-SAWS
 Cowan & Co..... 8

SAW SWAGES
 Hanchett Swage Works..... 29

SAW GAUGES
 Specialty Mfg. Co..... 12

STEAM BOILERS
 Canada Foundry Co..... 12
 Owen Sound Iron Works..... 41

SAWS
 Atkins & Co., E. C..... 37
 Burton Saw Co., A. J..... 39
 Burns Saw Co., E. R..... 1
 Buckeye Saw Mfg. Co..... 35
 Hoe & Co., R..... 40
 Shurley & Dietrich..... 9

SAW MILL MACHINERY
 Allis-Chalmers-Bullock..... 3
 Furniture City Tool Co..... 37
 Gordon Hollow Blast Grate Co..... 35
 Hamilton Mfg. Co., Wm..... 2
 Jenckes Machine Co..... 30
 Kendall, I. N..... 41
 Long Mfg. Co..... 7
 Lloyd Mfg. Co..... 7
 Manitoba Iron Works..... 33
 Mershon & Co., W. B..... 34
 Mowry & Sons, B. R..... 37
 Owen Sound Iron Works..... 41
 Petrie, H. W..... 1
 Payette & Co., P..... 32
 Schaake Machine Works..... 8
 Smart-Turner Machine Co..... 44
 Waterous Engine Works Co..... 42
 Williams, Madison..... 11

SHINGLE MILL MACHINERY
 Drake, F. J..... 36
 Long Mfg. Co., E..... 7
 Owen Sound Iron Works Co..... 41
 Schaake Machine Works..... 8
 Williams, Madison..... 11

STOVES
 Hall, Adam..... 40

TURBINES
 Williams, Madison..... 11

TRIMMERS
 Gordon Hollow Blast Grate Co..... 35

WOODWORKING MACHINERY
 American Woodworking Machinery Co..... 38
 Clark & Demill..... 3
 Connell & Dengler Machine Co..... 32
 Cowan & Co., Limited..... 8
 Dodge Manufacturing Co..... 10
 Defiance Machine Works..... 8
 Perkins & Co..... 39
 Rogers Iron Mfg. Co..... 35
 Sherman Co., W. S..... 35
 Shimer & Sons, Samuel J..... 39
 Waterous Engine Works Co..... 42

The . . .

QUEEN CITY OIL CO.
 LIMITED

Head Office: TORONTO.

HIGHEST GRADES OF

Refined Oils
Lubrication Oils

AND ALL

Petroleum Products

CANADIAN OFFICE & SCHOOL FURNITURE CO. LIMITED
 PRESTON ONT.

FINE BANK OFFICE COURT HOUSE & DRUG STORE FITTINGS. OFFICE SCHOOL CHURCH & LODGE FURNITURE. SEND FOR CATALOGUE.

ESTABLISHED 1849.

BRADSTREET'S
 Capital and Surplus, \$1,500,000.
 Offices Throughout the Civilized World.

Executive Offices:
 Nos. 346 and 348 Broadway, NEW YORK CITY, U.S.A.

THE BRADSTREET COMPANY gathers information that reflects the financial condition and the controlling circumstances of every seeker of mercantile credit. Its business may be defined as of the merchants, by the merchants, for the merchants. In procuring, verifying and promulgating information, no effort is spared, and no reasonable expense considered too great, that the results may justify its claim as an authority on all matters affecting commercial affairs and mercantile credit. Its offices and connections have been steadily extended, and it furnishes information concerning mercantile persons throughout the civilized world.

Subscriptions are based on the service furnished, and are available only by reputable wholesale, jobbing and manufacturing concerns, and by responsible and worthy financial, judiciary and business corporations. Specific terms may be obtained by addressing the company or any of its offices. Correspondence invited.

THE BRADSTREET COMPANY.
 OFFICES IN CANADA: Halifax N.S. Hamilton, Ont. London Ont.; Montreal, Que.; Ottawa, Ont.; Quebec, Que.; St. John, N. B. Toronto, Ont. Vancouver, B.C.; Winnipeg, Man.

THOS. C. IRVING,
 Gen. Man. Western Canada, Toronto

For Logging Tramways, Switches, Etc.
 New and Second-Hand.

RAILS YARD LOCOMOTIVES

John J. Gartshore
 83 Front St. West,
 (Opposite Queen's Hotel,) Toronto.

R. SPENCE & CO.
 Beech File Works.
 HAMILTON, ONT.
 FILE AND RASP MANUFACTURERS
 AND RE-CUTTERS

A trial order solicited. Write for price list and terms.
 C. P. MOORE, PROPRIETOR.

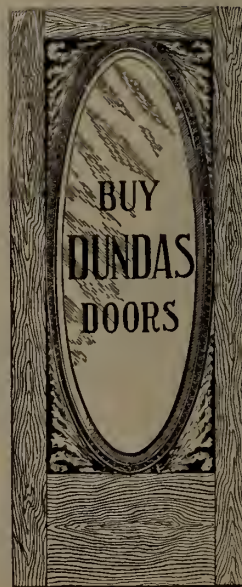

New Century Refrigerator & Manufacturing Co., Limited
 Dundas, Ont., Can.

Our Business is Manufacturing

HARDWOOD VENEER . . . DOORS

With Built Up Bodies

These Doors are guaranteed not to warp or twist and are superior in construction and finish to any other Door on the market.

Send for Illustrated Catalogue and Prices.
 Special attention given to Architects' Designs of Doors and Trims.

AGENTS WANTED EVERYWHERE. ADDRESS DOOR DEPARTMENT

DeLoach New Gang Edgers and Trimmers

WITH VARIABLE FRICTION FEED

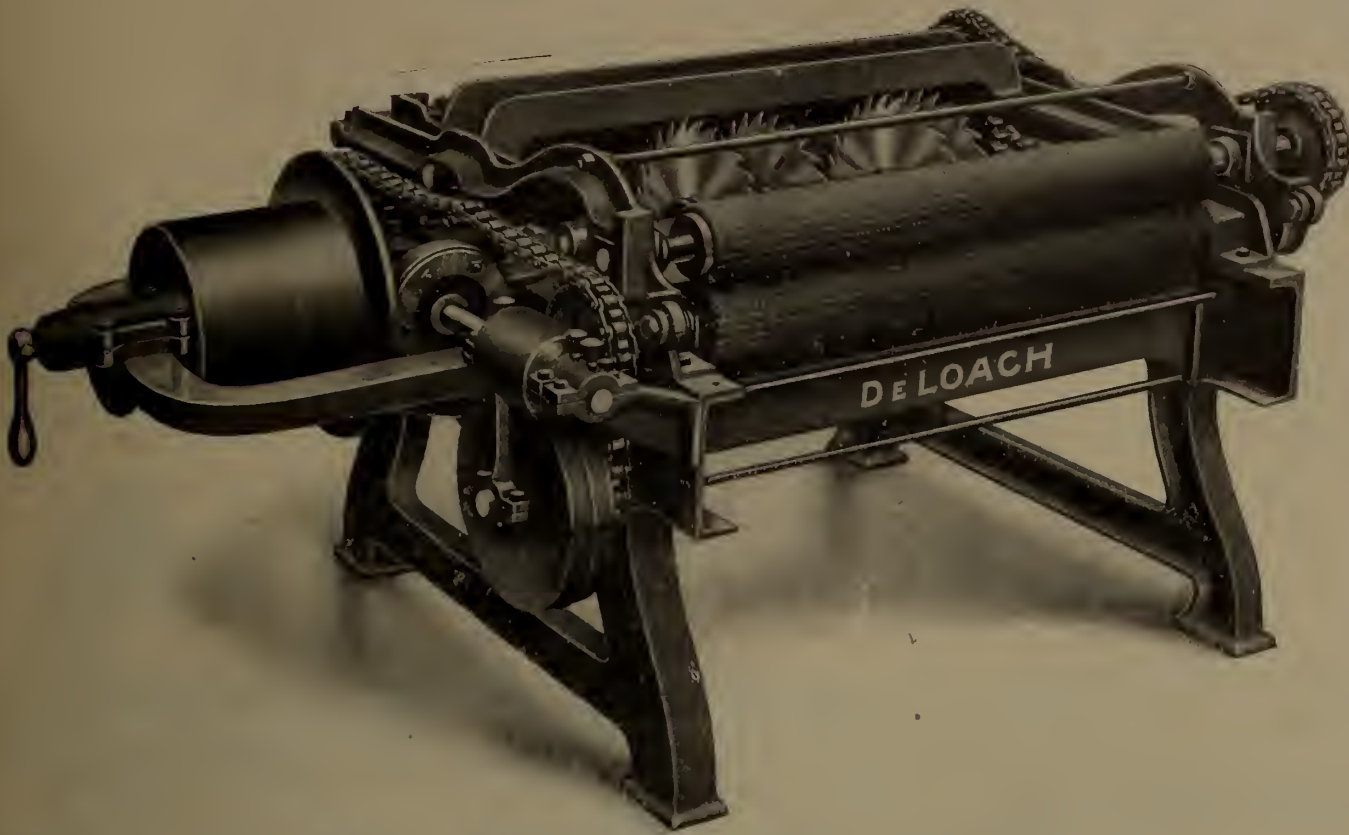

Edgers have power attachment for raising top rolls and three rolls corrugated and driven, and Trimmers have power attachment for operating head blocks.

Write for 144 page catalogue illustrating and describing our 1905 models of Saw Mills, Edgers, Trimmers, Planers, Shingle Mills and Lath Mills all with up-to-date variable friction feed, also Stave Mills, Corn Mills, Water Wheels and Hay Presses.

Our "Monarch" Saw Mill with One Mandrel and One Saw does the work of a double mill.

DeLoach Mill Manufacturing Company, Box 509, Atlanta, Ga.

THE TRIUMPH TURBINE



Is the most powerful wheel on the market to-day. A glance at this cut of the centre shows that the buckets are designed to secure the **maximum of speed with great power and a free discharge.** Mr. E. S. Edmondson, of Oshawa, writes as follows under date of November 16th, 1903, regarding a 26 inch Vertical Triumph Wheel:

"The Wheel is strictly first-class in every particular, and after a careful and thorough test I am prepared to say that I believe it is the best wheel in the market for Electrical purposes. It has high speed, large power, high efficiency at part gate, and has practically no leakage. I am more than pleased with the thorough and workmanlike setting you gave me throughout."

For horizontal settings in large Pulp Mills, Cement Mills or Electric Power Developments this Wheel has no equal. We invite your enquiries. Large catalogue to be had for the asking.

We are always glad to submit estimates and prices on **Improved Vulcan and Leffel Turbines, Improved Lane Circular Saw Mills, Edgers, Trimmers, Slashers, Shingle Machines, Lath Machines** and all machinery of this kind.

MADISON WILLIAMS

Successor to Paxton, Tate & Company
PORT PERRY, ONT.

Manitoba Iron Works
Western Selling Agents
Winnipeg, Man.

H. E. PLANT, Agent
Cor. Common and Nazareth Streets
Montreal, Que.

TEON BELTING



STEAM PROOF
WATER "
HEAT "
OIL "
ACID "

Stronger and Cheaper than
Leather.

LEATHER BELTING

CAPATA BELTING [BALATA TYPE]

CAMELS HAIR BELTING

LACE LEATHER, ETC.

Special Arrangements for Trial Belts.
Write for Price Lists and Discounts.

P. H. WILBY, 27 1/2 Front Street East, TORONTO

Phone Main 1930.

SOLE AGENT FOR CANADA.

Our special

Tram Car Wheels

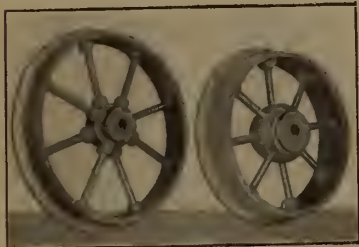

made from a special mixture of Iron,
are stronger, longer lived, low in
price and lighter for their strength
than any other wheel. Write
for prices and samples of metal.

MIDLAND ENGINE WORKS CO.
MIDLAND, ONT.

LARGE STOCK CARRIED & CUT TO ANY LENGTH

BLOCKS, CLIPS, TURNBUCKLES, ETC.

WIRE ROPE

SPECIAL ROPES FOR LUMBERING

DOMINION WIRE ROPE Co., LTD
MONTREAL, QUE.

EVERY LUMBERMAN WANTS IT

35 cents buys it

Scribner's Lumber and Log Book

BRIMFUL OF EVERY-DAY
PRACTICAL INFORMATION

Address:

THE CANADA LUMBERMAN, Toronto

STEAM BOILERS



Portable Boilers—Locomotive Style
Return Tube Tubular

Tanks, Water Towers, Smoke Stacks, etc.

CANADA FOUNDRY COMPANY, LIMITED

Head Office and Works: TORONTO, ONT.

District Offices: Montreal Halifax Ottawa Winnipeg Vancouver Rossland Calgary

Detachable Chain Belt

—AND—

CONVEYING

MACHINERY



William R. Perrin & Company

Limited

TORONTO, CANADA.

WOODWORKERS SAY

"The convenience to the Sawyer and
the saving in lumber make the
STANDARD AUTOMATIC SAW GAUGE
an article of much merit."



WRITE TO
SPECIALTY MFG. CO.
DETROIT
Mich.

Garlock Packing Co.

HAMILTON

CANADA

—SOLE MANUFACTURERS OF—



GARLOCK'S PACKINGS

PATENTED

Asbestos and Mineral Wool Pipe and Boiler
Coverings, Engineers' Supplies in General



THE CANADA LUMBERMAN AND WOOD-WORKER

VOLUME XXV. }
NUMBER 5.

TORONTO, MONTREAL — JUNE, 1905 — WINNIPEG, VANCOUVER

{ TERMS, \$1.00 PER YEAR
Single Copies, 10 Cents

THE BRITISH COLUMBIA MILLS, TIMBER & TRADING COMPANY.

Of all the long list of lumber firms on the Pacific Coast, the British Columbia Mills, Timber & Trading Company stands at the head. The company own the Hastings Saw Mill, Vancouver; the Moodyville Saw Mill, Burrard Inlet; the Royal City Saw & Planing Mills, Vancouver, and the Royal City Saw & Planing Mills, New Westminster. It is one of the oldest companies doing business in the West. The daily capacity of their combined mills is 500,000 feet of lumber, 200,000 shingles, 600 doors and 100,000 lineal feet of mouldings, in addition to other products.

The Hastings Saw Mill has been in active operation for the past 40 years and has been enlarged and remodelled so many times that to-day it stands as one of the largest and most thoroughly equipped in Canada. The capacity is 200,000 feet per day and it gives employment to 300 men. It possesses an unsurpassed wharfage front, at which nine vessels can load at once, with sufficient depth of water for the largest ship afloat. It has also numerous private sidings from the railways entering Vancouver, giving first-class transportation facilities both by land and water. Connected with the mill are large planing mills, dry kilns and a machine shop.

The Royal City Planing Mills are located on False Creek and consist of a saw mill, planing mill, sash and door factory and a lath and shingle mill. Their extensive ready-made house business is also conducted from this branch. It is equipped in a thoroughly modern manner and possesses unsurpassed transportation facilities by rail and water.

The Royal City Mill, New Westminster—Here is another saw mill, planing mill, sash and door factory, each equipped in the most modern manner and possessing the best of transportation facilities.

The Moodyville Saw Mill—This mill came under the control of the present owners in 1901.



CAMP VIEWS, BRITISH COLUMBIA MILLS, TIMBER AND TRADING COMPANY, VANCOUVER.

Five of the Company's standard-gauge locomotives. 2. Logging train and booms at Bear River Beach. 3. String of logs hauled by seven yoke of oxen. 4 and 10. Logs being hauled on skid road by horses. 5. Company's store at Rock Bay. 6. and 7. Water chute at Village Bay, 3,000 feet to Salt water, and 223 feet above the sea level. 8. Fallers at work. 9. Log chute.

It is equipped with every modern improvement and has a capacity of 120,000 feet per day of ten hours, employing a large number of hands.

The company possess magnificent limits from which they have several tugs constantly towing booms of logs to their various mills. They manufacture fir, cedar and spruce lumber, also shingles, laths, doors and mouldings. They market their stock to all parts of the world, their principal markets being Canada, Australia, United States, South America, Japan, China, South Africa and Great Britain.

The officers of the company are: John Herdry, president; C. M. Beecher, vice-president; and

JOTTINGS BY THE WAY

On the same train, headed towards the Rocky Mountains, the representative of the CANADA LUMBERMAN rode peacefully and contentedly with forty-five "lumber jack". This gang of men were engaged in Winnipeg to work for the Arrowhead Lumber Company, and were in charge of D. McDonald, railway contractor of Winnipeg, and Andrew Wright. Mr. McDonald is vice-president of the Arrow-

pine, hemlock and basswood are going like hot cakes!"

Going in by the Crow's Nest Pass Railway, some activity in lumber circles is noted at various points along the line. Peter McLaren is sawing at Blairmore, and the Wardrobe Bros. & Forrester have moved from Sparwood to Wardrobe Siding further in the mountains, where they are operating along the railway line.

A number of mountain mills expect to have trouble getting their cut out this spring. Owing to the light snowfall during the past winter there is not much chance of high water. June is the freshest season for the mountain



CAMP VIEWS, BRITISH COLUMBIA MILLS, TIMBER AND TRADING COMPANY, VANCOUVER.

1. Log chute, showing the effect when the logs strike the water. 2. Company's hotel at Rock Bay. 3. Exit of Stella Lake. 4. Shingle chute. 5. Fir log 8 feet in diameter. 6. Logging team of horses. 7. Operation of logging camp at Rock Bay. 8. Group of five logging engines, the company requiring twenty-six of these in their logging operations; they now entirely supersede the use of horses and oxen. 9. Logging engine at work on Stella Lake.

Richard H. Alexander, secretary. The managers of the different mills are: R. H. Alexander, Hastings Saw Mill; E. C. Mahony, Royal City Mills, Vancouver; Robert Jardine, Royal City Mills, New Westminster.

By the kindness of the British Columbia Mills, Timber and Trading Company, we are permitted to publish in this number several excellent illustrations showing their saw mills, factories, logging camps, etc. These are reproduced from the handsome catalogue recently issued by the company.

head Lumber Company and said the men were to be employed in the mill yards at Arrowhead, piling and loading lumber.

The limits of the Arrowhead Lumber Company are at the head of Arrowhead Lake, and the company did very little cutting during the past winter as they had a stock of logs lying in the boom. They manufacture white pine, fir and red cedar.

In conversation with a retail Northwest lumberman on the train he said:—"I can't get any price for elm, beech, birch or maple, but

mills and about the 15th of the month will be an anxious period for the lumbermen.

At Fernie there are but two mills in active operation, that of the Red Deer Lumber Company (formerly the Elk River Lumber Company) and the Fernie Lumber Company, the latter being run by Messrs. McDougall & Proctor, both lumbermen of considerable experience. A description of their saw-mill plant will be given in these columns. They own and operate a large limit in the mountains, consisting of a bunch of very fine timber.

In the Elk valley and around Fernie there is very little white pine—for miles it is practically non-existent, and Mr. Proctor, of the Fernie Lumber Company, told me that his company had cut just three pine trees in eight years!

Down deep in the valley of the Elk River at Fernie lie the new mills of the Red Deer Lumber Company. These mills are now almost completed and will have a capacity of 125,000 feet per day of ten hours, or nearly a quarter-million feet if a night shift is run. This plant is equipped with the latest machinery, band saws, etc. By a diversion of the river a canal or "log sluice" has been formed one mile long.

Mr. Boynton, the general manager of the Red Deer Lumber Company, is a man of wide experience with some of the largest concerns in the United States. He stated that the cut of the mill will run about equally fir, spruce, tamarac and cedar, with a small percentage of white pine.

The mountain tamarac or larch is not at all like the eastern tamarac. The spruce is a soft white wood with a red knot, very similar to white pine, and it grows very tall, oftentimes running eight or nine 16-foot logs in height up to the limbs. These will have frequently a diameter of three or four feet at the stump.

The East Kootenay Lumber Company's three mills have a capacity of over 140,000 feet per diem, sawing an excellent quality of timber. The North Star Lumber Company are running steadily and shipping it out to the prairies. Their logs are of a splendid grade. The Robinson-Mackenzie Lumber Company have a very fine quality of logs on hand. They are equipping a new planing mill and expect to have it ready very soon.

The Export Lumber Company, at Mayook, B.C., is situated about seven miles from Fort Steele Junction on the Crow's Nest Pass Railway, where they have a fine plant. A saw and



Box Factory Department, Royal City Mills, New Westminster.
Shingle Mill Department, Royal City Mills, New Westminster.
Sash and Door Factory Department, Royal City Mills, New Westminster.

Royal City Mills Branch, New Westminster.
Moodyville Saw Mill Branch, Burrard Inlet, opposite Vancouver.

THE BRITISH COLUMBIA MILLS, TIMBER AND TRADING COMPANY'S MILL PLANTS.

The neat appearance of the many workmen's cottages, the new planing mill, machine shop, power house, etc., all indicate the prosperity of this concern. Their triple battery of boilers, with automatic feed, develops over 400 horse power to drive the ponderous machinery. The engineer in charge said there was only a loss of 14 per cent. through feeding the wet saw-dust automatically, this loss being entirely due to the dampness, but this will be offset to a large extent when the planing mill gets to work and shavings will be used.

The fir is not as large in the mountains as on the coast, the average being 24 to 30 inches diameter at the stump, very tall and smooth. The mountain tamarac will run all the way from 18 to 48 inches in diameter on the stump. Cedar will run from one to five, and even six feet, at the stump.

It is peculiar how the timber varies and where it grows. Hemlock, practically unknown in wide areas east of the Mississippi River, is found at Revelstoke.

At Cranbrook all the mills are actively cut-

ting. The East Kootenay Lumber Company's three mills have a capacity of over 140,000 feet per diem, sawing an excellent quality of timber. The North Star Lumber Company are running steadily and shipping it out to the prairies. Their logs are of a splendid grade. The Robinson-Mackenzie Lumber Company have a very fine quality of logs on hand. They are equipping a new planing mill and expect to have it ready very soon.

At Elko the writer inspected the fine new

planing mill just completed for Mr. John H. Hanbury. Mr. Hanbury is connected with the Hanbury Manufacturing Company, of Brandon, and the North Star Lumber Company, Cranbrook. Elko is the junction point of the Crow's Nest Pass and the Great Northern Railways, situated close to the Elk River. The planing mill will be supplied by the portable and stationary mills in the surrounding country, receiving it in the rough and finishing it at Elko. The dry kiln is situated close to the planing mill and the sheds and piling grounds are situated between the two railways on their own ground, 23 acres of

A. G. Lambert & Company have a small mill running at Smith's Spur, about thirty miles from Nelson. Mr. Bell is manager and part owner. Mr. Lambert says that the U. S. mills were shipping their culls and rough stock into the smelter and mining towns of British Columbia all last year, putting this stuff in at \$3.50 less than the latter could sell it at. There is very little being dumped into B. C. from across the border this year, but there is no telling what they will do if something is not done to prevent it by the Government.

At Ymir the Porto Rico Lumber Company have a good mill running steadily; Mr. J. A.

Gaskin has a thriving plant known as the Kimberley Milling & Manufacturing Company. They manufacture lumber, mouldings, interior finish, etc., most of the output being disposed of through the Moose Mountain Lumber Company, of Winnipeg.

At Cranbrook I inspected the very nice plant owned by the Cranbrook Sash & Door Company. This company is composed of Messrs. McKowan, A. Slater, W. Slater, A. S. Nicholson and J. H. Spence. Besides sash and doors they make interior wood-work of all kinds. They have their own saw-mill and buy logs as required for their own use. Their



Royal City Mills Branch, Vancouver.
Hastings Saw Mill Branch, Vancouver.

Sash and Door Factory Department, Royal City Mills, Vancouver
Planing Mills Department, Hastings Mill, Vancouver.
Planing Mills Department, Royal City Mills, Vancouver.

THE BRITISH COLUMBIA MILLS, TIMBER AND TRADING COMPANY'S MILL PLANTS.

which was purchased by Mr. Hanbury. Between Elko and Jaffray there is considerable tie cutting going on. At Jaffray a great pile of saw-dust marks the spot of the former mill site, but the East Kootenay Lumber Company have removed back from the line to a better location nearer the timber. Most of the merchantable timber along the line has been cut off, but farther back some grand timber looms up. Otis Staples has a splendidly equipped mill at Bayard, B.C.

Dewar is the president. He says that the output this year will be about five million feet, consisting of western pine, fir and cedar, with a little larch. Their limits are on the Salmon River near Ymir. This enterprising company have bought out E. Simpson & Company's sash and door factory at Moose Jaw and will run the plant as a distributing centre for the Northwest, with R. McDougall in charge. Upon the North Star branch of the C. P. R., about 18 miles from Cranbrook, B. C., lies the mining town of Kimberley. Here Mr. C. A.

market is the retail lumbermen on the prairies. Owing to the rush of orders they had to cancel one large order. In the planing mill there are seventeen machines all of excellent makes, as follows: One large planer, extra large sticker, single tenoning machine, sash sticker, two mortisers, two sanders, shaper, molder, panel raiser, buzz planer, jointer, two turning lathes, scroll saw and a band saw. There is a capital dry kiln in connection. This enterprising company intend to increase their capacity so as to take care of every order.

At Cranbrook I met Mr. A. A. Carney, timber inspector for east and south-east Kootenay. Mr. Carney is very optimistic as to the British Columbia forestry product. He thinks that the prices asked for limits are very reasonable and will be called "snaps" in a few years.

Manners' mill is situated about four miles west of Cranbrook, making a small cut. A. E. Watts' mill is further west and is running steadily, cutting over twenty thousand daily.

Before reaching Moyie our train ran into a rocky slide. Mr. Alex. Leitch, President of the East Kootenay Lumber Company, was on the train and we congratulated each other on our

"chuted" into the pond from the top of the Yahk mountains. This company have some fine holdings along the Crow's Nest Pass route.

Near Creston a great lot of posts had been delivered at the side of the rails by a contractor who had cut them on the top of the mountain. There appeared no feasible way of bringing them down and still leave a profit, so he built a two-board V flume, which was held in place by uprights wherever necessary in crossing gullies, and into this a mountain stream was turned and the posts half floated and "chuted" to the track for shipment.

three planers going. A. N. Winlaw is the manager of this very complete outfit. Mr. Winlaw, sr., is very active and keeps things up-to-date and "on the go" continuously.

When I reached Slocan City the town was "resting." All the mines, excepting one employing a couple of dozen men, were closed down. The fine shingle mill plant of the Ontario Slocan-Company was lying idle. Mr. D. St. Denis, the energetic manager, said that, owing to the bad year of 1904, they had put in no logs and would not reopen until next winter. They make the famous Crown brand of red cedar shingles, so well liked in the East. Three



BRITISH COLUMBIA MILLS, TIMBER AND TRADING COMPANY'S HASTINGS MILL.

1. Entrance to yard, showing offices. 2. Company's horses used in their local business. 3. Dry kilns. 4. Company's exhibit, Labor Day. 5. Company's store, Vancouver. 6. Lumber yard "C". 7. Pile of split stovewood. 8. Lumber yards "A" and "B". 9. Record load of lumber, consisting of 6,007 feet of ceiling. 10. Car-loading scene.

escape from being hurled over the precipice and taking a forced plunge in the cold waters of Moyie Lake. With slight damage to the engine and some excitement the line was cleared of the fallen rock and Moyie was reached. Here the Moyie Lumber Company's mill is situated but at present not running—awaiting a purchaser.

A little further on is Ryan, where one of the East Kootenay Lumber Company's mills is located. The mill is going full blast with a great crop of logs in the pond. These logs are

J. B. Winlaw is operating at Winlaw, about midway between Nelson and Slocan City, on the Slocan river. Here he has erected a very nice permanent mill, using a 56-inch circular saw, "Gunshot" Waterous steam feed carriage, with double dogs. They are sawing western pine, fir, cedar, larch and some spruce. They have also cut a small amount of hemlock. The probable cut this year will be between three and four million feet. They also make lath, but like most of the Kootenay mills, do not make shingles. In the planing mill they have

fine Letson & Burpee shingle machines and an Orillia Clipper combine to furnish a capacity of one hundred thousand shingles per day of ten hours. The company's limits are on Bonanza and Wilson creeks, where they are rafted and towed to the mill at the foot of the Slocan Lake by their own tug. The mill site is a splendid one covering twenty-five acres, the limits being 21 miles in extent. The fire-proof boiler house, dry kiln that holds 300,000 shingles, machine shops, &c., are very complete and kept in fine order.

LARCH FOR INTRIOR FINISH.

A great many people erroneously call larch "tamarac," when as a matter of fact there is very little similarity. The British Columbia larch is a beautiful wood, and makes splendid interior finish. Some of the Northwest retailers call this wood mountain tamarac.

The manager of the Otis Staples mill at Bayard, B.C., says:

"Larch, or mountain tamarac, as some prefer to call it, is the best wood going for putting in cars. It is an ideal wood for

The manager of the Fernie Lumber Company, at Fernie, B. C., also says larch is not tamarac, but many people have been calling it "tamarac" erroneously.

At the offices of the East Kootenay Lumber Company in Cranbrook, B.C., can be seen a most beautifully finished room, all the interior being of larch. It is a superior wood to pine for interior work, mouldings, ceilings, siding, flooring, etc. A pine floor will show the marks of boot nails, but larch shows no perceptible wear or indentation from boot nails, even after

be taught that larch is superior to pine. The carpenter prefers an easy wood to work. A man building a house for himself, if he knows what he is about, will use larch."

In order to show what a fine finish can be put on this wood, the Cranbrook Sash & Door Company made up several wood over-mantels from larch. They were pronounced equal in appearance to any hardwood mantels.

Mr. Mackenzie, of the Robinson-Mackenzie Lumber Company, said a large retail dealer wanted a quantity of "redwood" lumber and



BRITISH COLUMBIA MILLS, TIMBER AND TRADING COMPANY'S HASTINGS MILL.

1. Interior of saw mill, showing log 8' feet in diameter being turned on the carriage. 2. Portion of engine room interior. 3. Portion of planing mill interior. 4. Dynamo room. 5. Band saw filing room. 6. Fire room. 7. Interior of machine shop. 8. Circular saw filing room.

interior work of all kinds. Railway and street cars require wood that will hold the nails and once a nail is properly driven in larch it cannot be drawn out without splitting the wood."

The manager of the Elk Lumber Company at Fernie, B.C., says:

"The mountain tamarac, or larch, as it should be called, is not at all like the eastern tamarac. It runs all the way from 18 inches to .4 feet in diameter at the stump. Larch cannot be beaten for interior finish. It is a wood that has not received proper attention."

years of constant use. The East Kootenay Lumber Company make a specialty of larch for all purposes and have an enormous quantity of well-seasoned stock on hand for shipment.

Speaking to the president of the East Kootenay Lumber Company recently, at Cranbrook, he said: "Larch has a beautiful grain and can be finished better than maple. It is a close-grained wood and particularly suitable for interior work. Larch is hard and tough and will outlast white pine as well as keep its finish much better. The architects will have to

was told that he evidently wanted "mountain tamarac." He said "No, I don't want any tamarac." He was shown some pieces of larch, finished, and immediately said "that is what I have been calling redwood." And he bought a car of it, stating that nothing could beat it for the interior work of a house.

"It is a wood that can be beautifully finished and should be specified by architects," said Otis Staples, "as many are beginning to see the use of larch and the demand is bound to increase."

NEW OWEN SOUND MILL.

The Carney Lumber Company, Limited, commenced building their new mill in Owen Sound on April 1st. It will contain two band and gang saws, edgers, trimmers and slashers, the entire equipment being most modern. The machinery will be the same as used by H. Whitbeck & Company, Marinette, Wis., of which company Carney Bros. were the controlling stockholders. This machinery has already reached Owen Sound, having been

opportunity is presented. The entire output of lumber of this season has been sold to the Edward Hines Company, Chicago.

MICHIGAN HARDWOODS.

There were manufactured in the State of Michigan last year 618,000,000 feet of hardwood lumber. In 1903 the total product of the state was 475,453,066 feet, and in 1902 it aggregated 438,000,000 feet. While the total

intended for decoration as might be supposed, but are used for a highly practicable purpose. The saws just finished ranged in size from 60" to 75" in diameter and are to be used for sawing stone. They have proven very satisfactory wherever used. This style of saw is known as the "Scotch saw" and is specially designed for machines made in Scotland.

Instead of being fitted with sharp teeth like the ordinary saw, these "saws" are large discs with about 150 sockets $\frac{3}{4}$ " deep by $\frac{1}{2}$ " wide and $1\frac{1}{4}$ " apart around the outer circumference, into which are inserted little steel blanks or teeth which project about $\frac{1}{8}$ " from the edge of the blade. In the top surface or edge of each



BRITISH COLUMBIA MILLS, TIMBER AND TRADING COMPANY'S HASTINGS MILL.

1. Shipment of timber made to the Montreal Harbor Commissioners, the principal sticks of which were 3 feet square by 72 feet long. 2 and 6. Mill boom. 3. Shipping scene, showing 9 ships loading. 4. Shipment of spars to Halifax, Nova Scotia. 5. Shipment of timber to Sorel, Quebec; the longest of these timbers was 98 feet 6 inches, this being the greatest length ever shipped by rail out of British Columbia. 7. Shipping scene. 8. Company's pile-driver. 9. Scow-loading scene.

put on barges and towed there direct.

The equipment of the Whitbeck Company's mill has always been kept up-to-date and the same will be done in the new mill at Owen Sound. They expect to be operating by July 15th next.

The limits of the Carney Lumber Company are located on the Spanish River and the logs will be towed from there to Owen Sound. They cut about ten million feet this year and expect an annual cut of about 15 to 18 million after this season. The timber limits already owned by the company will stock the mill for ten to twelve years and will be added to as

lumber production in Michigan in 1904 was 276,000,000 feet less than it was in 1903, the hardwood output has steadily increased. It is likely to continue to do so for some time, as hardwood is being sought with more eagerness than a few years ago, and there are large tracts of hardwood timber yet to be developed in the upper peninsula.

SAWS STUDED WITH DIAMONDS.

E. C. Atkins & Company, the enterprising saw manufacturers of Indianapolis, Indiana, have recently been turning out some large circular saws studded with diamonds, a comparatively new departure in the saw line. The diamonds, while rather expensive, are not

tooth is imbedded a black diamond about one-half karat in size. These diamonds are set in various regular positions, that is, in one tooth the diamond would be at the right edge, in the next tooth about the centre, in the next at the left edge, in the next in the centre and so on. Being set in this manner the diamonds take the place of teeth in the ordinary saw and when in contact with the stone will saw a kerf about $\frac{1}{4}$ " wide.

The diamonds used in these saws come from the South African diamond mines and cost about \$6 each, and the value of each completed saw is in the neighborhood of \$1,000.

James Sparling, Meaford, Ont., is making necessary improvements by enlarging his mill 36x40 feet, two stories. He has also doubled the capacity of his dry kiln.

THE Canada Lumberman

AND WOOD-WORKER

(Monthly and Weekly Editions—One Dollar Per Year.)

PUBLISHED BY

The C. H. Mortimer Publishing Company
of Toronto, Limited,

CONFEDERATION LIFE BUILDING, TORONTO

BRANCH OFFICES:

38 ALLIANCE BUILDING, MONTREAL
720-721 UNION BANK BUILDING, WINNIPEG
22 GREAT ST. HELENS, LONDON, E. C.

The LUMBERMAN Weekly Edition is published every Wednesday,
and the Monthly Edition on the 1st day of every month.

TERMS OF SUBSCRIPTION:

One Copy, Weekly and Monthly, One year, in advance, \$1.00

One Copy, Weekly and Monthly, Six Months, in advance, 50

Foreign Subscription, \$2.00 a Year

ADVERTISING RATES ON APPLICATION.

THE CANADA LUMBERMAN AND WOOD-WORKER is published in the interest of and reaches regularly persons engaged in every part of Canada in the lumber, wood-working and allied industries. It aims at giving full and timely information on all subjects touching these interests, and invites free discussion by its readers.

Special care is taken to secure for publication in the WEEKLY LUMBERMAN the latest and most trustworthy market quotations throughout the world, so as to afford to the trade at home and abroad information on which it can rely in its operations.

Advertisers will receive careful attention and liberal treatment. For manufacturing and supply firms wishing to bring their goods to the attention of owners and operators of saw and planing mills, wood-working factories, pulp mills, etc., the CANADA LUMBERMAN AND WOOD-WORKER is undoubtedly the most direct and profitable advertising medium. Special attention is directed to "WANTED" and "FOR SALE" advertisements, which are inserted in a conspicuous position on front page of the Weekly Edition.

OUR VANCOUVER OFFICE.

The publishers of this Journal have recently established an office in Vancouver for the purpose of looking after more carefully the interests of subscribers and advertisers in British Columbia. This office is located at 536 Hastings Street, Suite 3, opposite Molson's Bank, and is in charge of Mr. G. A. Gall, who will be pleased to meet any of the friends of this Journal, and to serve their interests in any possible way.

TOO LITTLE INFORMATION.

It is to be regretted that more information is not readily available concerning the native woods of Canada. A few people know well the characteristics of those woods which they may have been using for some years, but how many are familiar with all the different varieties to be found in plenty in this country?

Like carrying coals to Newcastle, a New Brunswick concern has recently imported a quantity of fir from Washington, to be used for gutters, also some California redwood for finishing material, chiefly inside finish. The long lengths in which fir is obtainable gives it a great advantage for gutters, but why not use the Douglas fir of British Columbia? And does the California redwood meet the requirements of this consumer better or at a lower cost than any timber to be obtained in Canada? It may be that in this particular instance it does, but we believe that many times timber is imported from the United States before the possibility of obtaining a suitable article at home is thoroughly investigated.

With a wider public knowledge of our native timbers, fewer orders would find their way across the line. Steps should be taken to familiarize the consumer with the different woods, their adaptability for various purposes, the dimensions in which the lumber may be obtained, and the general methods of treatment, also the locality in which they may be obtained. It is the lumber manufacturers of this country

that would be benefitted by such a policy and it is by the manufacturers that such an advertising campaign should be commenced and conducted. The handsome booklet published by the Yellow Pine Manufacturers' Association, and being a reproduction of the World's Fair cottage in yellow pine finish, is a splendid illustration of what might be done. It represents business for the southern manufacturers.

Are we doing all we can to encourage the consumption of Canadian timber and timber products?

FLAT CAR EQUIPMENT.

Touching again the subject of the equipment of flat cars for the carrying of lumber, discussed in the May number, we have since been afforded an opportunity of reading the act passed by the state of Florida making it compulsory on the railroads to provide the necessary stakes, etc. Section 1 of the act stipulates that every railway company shall supply and equip flat cars with "all proper or sufficient standards, supports, stays, strips, railings and other equipments and appliances necessary to hold and keep the cargo firmly in place"; while section 2 provides that "the weight of such appliances shall be added to the weight of the car and shall be deducted from the weight of the cargo of lumber shipped so that the freight charges shall be charged by the carriers only on the cargo shipped." Provision is made that for every car not so equipped the railway company must pay the shipper the sum of \$1.50, which may be secured by a lien on the car. Similar legislation has been passed by the state of Washington, to take effect June 15, 1905, and efforts are being made to induce the Legislature of Georgia to take steps this month in the same direction.

The skill of the inventor is now required to devise the most satisfactory permanent equipment, and it may be expected that the railroad companies will prefer that the experimental work shall be done before they go to the expense of fully equipping the necessary rolling stock, for which reason there is likely to be some delay in complying with the law.

Already different appliances have been tested. The Georgia Southern & Florida Railway devised a removable wooden standard, which was simply the old style stake, but instead of being stripped together, the top ends were joined with a chain, with hook in one end; when the stakes were not in use, they were kept underneath the car in a box and were always available for the shipment of lumber. This standard was found to be satisfactory except when the load would bind.

Some southern lumbermen also devised a standard, which worked on a bolt, was slotted, and kept erect by a bottom socket. When not in use the stake was lowered, turning on the bolt and resting by the side sill of the car. In the event of the load binding, the stake was loosened by turning the bolt tap. This standard is considered quite practical, but has not yet been accepted by the railroads.

The progress made in the United States towards obtaining permanent flat car equipment for lumber will strengthen the hands of the

committee of the Ontario Lumbermen's Association appointed for a similar purpose, and a favorable ruling by the Railway Commission may be expected. The responsibility of completely equipping a car for the duty it is designed to perform should be assumed by the railroad company, and the lumbermen should keep everlastingly at it until the desired end is accomplished.

OBSTRUCTIONS IN THE ST. JOHN RIVER.

A number of St. John river lumbermen have appealed to the New Brunswick Supreme Court in equity for an injunction to restrain the St. John River Lumber Company, of Van Buren, Maine, from placing any obstructions on the Canadian side of the river. The outcome of the fight which has been commenced will be awaited with great interest, as upon it will depend in some measure the future of the city of St. John as a sawmilling centre.

The magnitude of the lumber industry at St. John, as well as Fredericton and one or two other points, is due partly to the operations of Americans, the Pike law permitting the product of the forest of the state of Maine upon the St. John river and its tributaries, owned by American citizens, and sawn in the province of New Brunswick, to be imported into the United States free of duty. When this law was first passed, there was no railway or water outlet to the New England consuming markets for lumber cut in Maine, consequently many American firms established mills at St. John and floated their logs down the St. John river. The situation has changed, however, and the building of railroads has made the Maine forests available for the mills on the American side. Consideration has even been given to the prospect of diverting the prosperous lumber industry of the Lower St. John river to points where it would be of greater benefit to the citizens of the United States, and by some it is believed that the desire to bring about such a result is responsible in part for the present dispute.

A portion of the St. John river forms the boundary between Maine and New Brunswick. The St. John Lumber Company have established a large saw mill on the American side of the river near Van Buren, where they are now operating certain shear booms which deflect the logs from their regular course into their sorting boom, at the foot of which the logs are assorted, those destined for the St. John Lumber Company being put into a storage boom and those destined for lower points on the river being shoved out of the boom and carried by the shear booms back to the Canadian side. The lumbermen of the Lower St. John river claim that their logs are thus delayed and that the works are illegal and contrary to the terms of the Ashburton treaty, and this is the question which the courts have been asked to decide. The Ashburton treaty provides that where the St. John river is the line of boundary between the two countries, the navigation of said river shall be free and open to both parties and shall in no way be obstructed by either. A strict interpretation of the language of the treaty would seem to exclude the placing of shear

booms on the river, but the Maine lumbermen claim that it is no violation of the law inasmuch as dams, booms, and similar works of construction to facilitate rafting operations are quite common.

The New Brunswick interests are desirous that the matter should be adjusted by the International Deep Waterways Commission, but it is understood that the United States do not consider the discussion of navigation on the St. John river as being within the scope of the Commission.

LUMBER TRADE ORGANIZATION.

The final organization, within the past month, of the Lumber Trade Association of the Montreal Board of Trade, is a step with which we are in entire sympathy. We are only sorry that its scope is likely to be confined to the city of Montreal, for we know the need of a provincial organization of manufacturer and dealers. Nevertheless, half a loaf is better than no bread, and we shall take comfort in the possibility, if not the probability, that this association may give the necessary inspiration for the formation of a body with a wider scope and influence.

Already the usefulness of the Montreal Association has shown itself in the interview with the representatives of the railways on the

THE J. E. MURPHY LUMBER COMPANY.

The accompanying illustration represents the mill of the J. E. Murphy Lumber Company, Limited, built in the fall of 1903, at Milford Haven, on south-east end of St. Joe Island, about 45 miles east of Sault Ste. Marie. The mill is 36x100 feet, with boiler house attached 33x36 feet, the latter built of stone, and all roofed with corrugated iron. The mill is rotary, and has shingle and lath mills attached, as well as a planer and matcher.

The Company have their own blacksmith shop and general store, with several houses for workmen, all of which have been erected since the first sod was turned in September, 1903. There has also been constructed pile docks with 100 feet of waterfront on 13 feet depth of water, for convenience of loading lumber, shingles, lath and mill wood, the latter finding a ready market at the "Soo".

The harbour is one of the best and safest on fresh water, having sufficient depth to carry the largest vessels, and is thoroughly protected by high lands in every direction excepting the entrance. There is an abundance of shallow water for log pond at the head of the harbour, and Hilton river extends a distance of twelve miles toward the interior of island and has sufficient water to float timber in the spring of the year from its origin in Hilton Lake, a small

formation to any one interested in establishing such an industry.

Bruce Mines, a station on "Soo" line of C. P. R., is only twelve miles distant, where every convenience is offered rail shipments for local or export points. The active managers of the Company are Mr. Murphy's four sons, H. F., Chas. E., J. E., and Oliver A., and Mr. Gordon McPherson, of Stratford, all of whom are permanently located at the mill and ready at all times to contribute to the public requirements in dimension timber of any length or size in hemlock, pine or cedar in cargo lots. The address is Milford Haven.

NATIONAL WHOLESALE LUMBER DEALERS' ASSOCIATION

A meeting of the Executive Committee of the National Wholesale Lumber Dealers' Association was held at 66 Broadway, New York City, on May 4th. Matters of importance were discussed, and a report rendered to the Board of Trustees, who met on the following day. The reports indicated substantial progress to have been made since March 1st, and particularly in the membership of both the Association and Bureau. The Trustees decided to accept the invitation of the lumbermen of the Ottawa Valley to hold a mid-summer meeting in Ottawa about the



NEW MILL OF THE J. E. MURPHY LUMBER COMPANY AT MILFORD HAVEN, ONT.

subject of freight rates, a hearing having been obtained such as could not be expected by individual concerns. Several other questions pertaining to the conduct of the lumber trade are to receive consideration and will doubtless be adjusted in a manner more satisfactory than would have been possible without united effort.

We would like to see in Canada a national association of manufacturers, similar to that of the United States, which would consider the many problems pertaining to the economical production and utilization of lumber, and, if found practical, the subject of inspection rules also. When timber was more plentiful and less valuable, there did not exist the same necessity of adopting the latest methods and machinery to secure the maximum of production at the minimum of cost, but conditions have changed, and it is now as essential to employ every possible labor-saving device in the manufacture of lumber as in any other branch of industry. The utilization of the waste product of saw-mills is in itself a subject of the greatest importance to manufacturers. What a vast amount of knowledge could be gained from annual conventions of the lumber manufacturers and woodworkers of Canada! Let us hope that the suggestion may so fasten itself upon the minds of some of our readers as to result in the realization of the much to be desired end.

body of water in interior of island. Although the island has been lumbered on for many years for pine and cedar, there is still large quantities of birch, maple, beech, hemlock and large cedar, for all of which there is now a good market.

The Company own 4,000 acres of timber, but are reserving this and buying stock from settlers and lumber loggers for their present use.

Mr. J. E. Murphy, who previously lumbered at Murphy and Hepworth, in Counties of Grey and Bruce, for twenty years, is president of the Company and resides at the mill. He will no doubt be glad to hear from any of his old customers who may want mixed cargoes of lumber, shingles, laths or cedar posts of any size or length. The Company have a mail service twice a week to the post office at the mill, and as the village grows in population, expect before the end of next summer to have a daily mail. A village has been surveyed by the Company and the lots are being rapidly taken up by working men who purpose building thereon and moving their families in.

There is a good opening here for the manufacture of birch, maple and beech turned goods, such as cant-hook stocks, neck-yokes, whiffletrees, dowels, bobbins, spools, etc., there being an abundant supply of white birch, beech and small straight-grained second growth maple. The company will be glad to supply further in-

formation to be announced later. The arrangements will be left in charge of a committee to be appointed by President Dill, consisting of members in the United States and Canada. This is a new departure, and reports indicate that the meeting will be well patronized, and it is believed in this way a large number of Canadian wholesalers will become more familiar with the Association work.

OBITUARY.

George McLeod, one of the most prominent residents of St. John, N. B., died in that city on May 7th after a few days illness following a stroke of apoplexy. He was born at Richibucto, N. B., in 1835, and was the son of the late William McLeod, a leading lumber operator of the province. Deceased studied law and graduated as a barrister, but never practised. Instead he joined his father in the lumber business and carried on extensive operations until some twenty years ago. He was a partner of the lumber firm of Holderness & McLeod, of Richibucto. The partnership was dissolved when Mr. Holderness went to England. Mr. McLeod then did business on his own account, lumbering on the Miramichi and at Kingston, Kent Co., and shipbuilding in the latter county. He was also active in political circles, being first elected in 1874 as Liberal representative for Kent County in the Dominion Parliament.

The Sprague Lumber Company and the Alex. Black Lumber Company have each subscribed \$250 towards a new Presbyterian church to be built in Point Douglas, Winnipeg.



GOING TO MIDLAND?

This question should be answered in the affirmative by all good Hoo-Hoo on June 30th, for arrangements have been made for doings at Midland on that evening. The local Black Cats have invited the Hoo-Hoo of the world to visit them. They will be borne across the bosom of the Georgian Bay in a special steamer to beautiful Honey Harbor, where the assembled tribe will celebrate and hold a record concatenation. Saturday being Dominion Day and a public holiday, a splendid opportunity for a week-end outing is afforded and a very enjoyable time is assured.

Mr. Frank Moores, one of the active local spirits, in writing to the CANADA LUMBERMAN, says: "We are to leave Midland for Honey Harbor at 5 p.m. June 30, giving the kittens and the older cats three hours to view Midland and the saw mills and lumber and logs galore. We arrive at Honey Harbor at 6 p.m., where we camp for the night and where I trust a few surprises await the boys. There is ample hotel accommodation for all, and A1. Steamer will leave early in the morning July 1, making



ROYAL HONEY HARBOR, WHERE CONCATENATION WILL TAKE PLACE.

connections with the 7 a.m. train leaving Midland for all points. Those wishing to remain can do so, and leave later on boat arriving at Midland about noon, in good time for the 3.20 p.m. train for all points. Those who desire to

spend a day or two in Midland can enjoy themselves boating, fishing, etc."

Midland is an appropriate place for a gathering of lumbermen, as it is one of the best known and one of the largest lumber centres in Ontario. Situated here are four large saw mills equipped with the latest and best machinery, one belonging to Playfair &



OFFICE OF TURNER LUMBER CO., MIDLAND, ONT.

White, who cut their own timber, another belonging to the firm of Chew Bros., who cut their own stock and also cut for the Herman H. Hettler Lumber Company, of Chicago, whose Canadian office is located there. The other two saw mills belong to Manley Chew and Norman L. Playfair respectively and cut the stock of the Turner Lumber Company, a firm operating extensively also at South River but having its head office here. A cut of the handsome office of this company appears on this page. The total yearly output of the Midland mills is close to 100,000,000 feet.

There is also located at Midland the box shoo factory and planing mill of the Georgian Bay Shoo Mills Company and the planing mill of J. Hill & Son. Considerable business is also done in hardwood lumber and hemlock by D. S. Pratt, and there is the retail yard of John Letherby.

Besides the lumber business, Midland is a well known grain port and has as other important industries the large plant of the Canada Iron Furnace Company and the shops of the Georgian Bay Engineering Works and the Midland Engine Works.

Connected with the lumber interests is the important business of towing lake rafts, which is done by the Midland Towing & Wrecking Company with their extensive outfit of lake tugs and booms.

Not far distant from Midland are the large mills situated at Penetang, Victoria Harbor, Waubaushene, Sturgeon Bay and Fesserton. At Midland and within its immediate vicinity is produced an annual cut of pine lumber of about 250,000,000 feet.

The names of the Midland Hoo-Hoo giving the concatenation are Mayor D. L. White, jr., Manley Chew, Frank Moores, Joseph A. McDonald, Norman L. Playfair, David S. Pratt, Fred Potvin, Harry Shanacy, Charles Shaw and Dwight J. Turner.

LAMENTABLE DEATH OF MR. W. H. TANNER.

Mr. William H. Tanner, the surviving member of the well-known lumber firm of Tanner Bros., of Waubaushene, Ont., met with a shocking death in his mill at Tannerville last month. He essayed to cross in front of the carriage connected with the band saw. Just at the moment he was on the tracks, the man in charge, who had not observed him, pulled the lever, and the carriage, bounding forward, threw Mr. Tanner against the saw. His back struck it, and he received a terrible gash, eight ribs being severed from the backbone and one of his lungs exposed. The guide to the saw saved him from instant death. As it was, he lingered till the following day and passed away, retaining consciousness to the end, and attending to the closing of his affairs.

Mr. Tanner, who was in his sixtieth year, was a native of Fonthill, Ontario. He had been a resident of Tannerville for upwards of thirty years, having come there first to work in the mill established by his father, of which he and his brother shortly afterwards took the management. Deceased's brother and partner, Mr. George Tanner, died of pneumonia only three months ago. Both were highly respected and capable business men, and had acquired considerable fortunes.

Mr. Tanner was married twenty-seven years ago to Miss Caroline Caswell, of Coldwater, who survives him with three sons and two daughters. The sons are Morley, Milton and Melville, and all reside at Tannerville, the first named taking an active part in the business. Deceased is also survived by both his parents.

It is probable that the business will be continued by the members of the two families. The mill had just started up for the season when the accident occurred.

SPECIAL TO LUMBERMEN, MINERS AND RAILWAY CONTRACTORS



We are Manufacturers of
**MINCE MEAT, BAKING POWDER,
COFFEE, SPICES, FLAVORING
EXTRACTS, MUSTARDS, &c.**

And all kinds of Grocers' Sundries
for Camp Use.

Mince Meat put up in 75 pound Tubs, 1/2
Barrel about 300 pounds, Barrels about
600 pounds.

Special Attention Given to Mail Orders

The Capstan Manufacturing Co., TORONTO,
ONT., CAN.

"STERLING" OILS

FOR SAW MILLS

WE SOLICIT ORDERS
TRADE LARGE AND SATISFACTORY
OUR AGENTS WILL CALL WITH "STERLING" CYLINDER,
ENGINE, DYNAMO, MACHINE AND SPECIALTY OILS

*Greases, Packing, Waste, "Copperine," Ready Mixed Paints,
Varnish, Red and Black Roof Paint; Smoke Stack Black for Boiler
Fronts and Sawmill Refuse Burners, White Lead, Dry Colors, Etc.*

Canadian Oil Co., Limited
Strachan Avenue, TORONTO, ONT.

CANADA LUMBERMAN

AND WOOD-WORKER

WEEKLY EDITION

The Lumberman Monthly Edition, 44 pages } \$1.00 PER YEAR {The Lumberman Weekly Edition every week.

THIS PAPER REACHES REGULARLY THE PRINCIPAL LUMBER MANUFACTURERS AND DEALERS THROUGHOUT CANADA, AND WHOLESALE BUYERS IN GREAT BRITAIN, THE UNITED STATES, AND OTHER FOREIGN MARKETS.

VOL. XIII

TORONTO, MONTREAL — JUNE 7, 1905 — WINNIPEG, VANCOUVER.

No. 14

CANADA LUMBERMAN

PUBLISHED BY

The G. H. Mortimer Publishing Co'v
of Toronto, Limited

Confederation Life Building - TORONTO

Branch Offices:

33 ALLIANCE BUILDING, MONTREAL
720-721 UNION BANK BUILDING, WINNIPEG.
536 HASTINGS ST., SUITE 3, VANCOUVER, B. C.
22 GREAT ST. HELEN'S, LONDON, E. C.

The Weekly Lumberman — Published every Wednesday, contains reliable and up-to-date reports of market conditions and tendencies in the principal manufacturing districts and leading domestic and foreign wholesale markets. A weekly medium of information and communication between Canadian timber and lumber manufacturers and exporters and the purchasers of timber products at home and abroad.

The Monthly Lumberman — A 44-page journal, discussing fully and impartially subjects pertinent to the lumber and wood-working industries.

WANTED AND FOR SALE

Advertisements will be inserted in this department at the rate of 15 cents per line each insertion. When four or more consecutive insertions are ordered a discount of 25 per cent. will be allowed. This notice shows the width of the line and is set in Nonpareil type; 12 lines make one inch. Advertisements must be received not later than 4 o'clock p. m. on Tuesday to insure insertion in the current week's issue.

WANTED—3" TAMARAC 14' AND 16' LONG, 1", 1 1/2" and 2" Wormy Chestnut. R. E. KINSMAN, Hamilton, Ont.

EXCELSIOR WOOD WANTED—PEELED basswood or clear spruce. RANKIN AND Co., Dundas street, Toronto. Telephone.

FOR SALE—ONE MILLION FEET BIRCH lumber, 100,000 feet Winter cut Basswood, a quantity of Beech, Maple, Black Ash, and Elm. Address THE HARCOURT LUMBER Co., Harcourt, Ontario.

WANTED—BY A YOUNG MAN OF GOOD character, position as Buyer, Culler, Etc., for a good reliable firm, with chance for advancement. Thoroughly acquainted with lumber business, especially Canadian Hardwoods. Apply to "C. M. M." care CANADA LUMBERMAN, Toronto, Ont.

WANTED, TO CORRESPOND WITH PARTIES who can arrange to cut and manufacture into lumber and shingles one hundred to one hundred and twenty five million superficial feet Fir and Cedar logs at the rate of about fifteen million feet per year. Logs will be delivered at the mill and product accepted F.O.B. cars and scows. None but those having capital to erect their own mill need apply to P. O. Box 798, Vancouver, B. C.

FOR SALE—FOR IMMEDIATE SHIPMENT

300M ft. winter cut Basswood 1".
200 " " " B. Ash, 1" and 2".
500 " " " S. Elm, 1".
100 " " " H. Maple, 1".
300 " " " Red Birch, 1", 2", 3" and 4", and Squares.
Box 111, CANADA LUMBERMAN, Toronto.

CEDAR FOR SALE

FOR IMMEDIATE SHIPMENT:

2 cars 7 x 7
2 cars 8 x 8
1 car 9 x 9
1 car 10 x 10

Very dry. OTTAWA LUMBER Co'y, Ottawa, Ont.

FOR SALE

300 DOLLARS BUYS AN ALMOST NEW Planer and Matcher (Cowan & Co. make), weighs about 4,500 lbs., has slotted cylinder and drop-heads, and is in first class running order. Apply to

H. L. MERRITT,
Blenheim, Ont.

FOR SALE—PORTABLE SAW MILL, NOW running, good rig and cheap. Box 4, Bothwell, Ont.

WANTED—TEN THOUSAND CORDS Hard and Soft Wood; also same quantity of Slabs. SIMCOE WOOD AND LUMBER Co., 52 Yonge Street Arcade, Toronto.

WANTED—A BUSH FOREMAN, ONE WHO understands logging hardwood, hemlock and cedar. Apply stating experience, etc., to Box 215, CANADA LUMBERMAN, Toronto.

FOR SALE

TIMBER LIMITS IN BRITISH COLUMBIA; good locations. Address Box 218, CANADA LUMBERMAN, Toronto, Ont.

WANTED TO PURCHASE.

50M ft. of 1" Hemlock, No. 1.
50M ft. of 1" Hemlock, No. 2.
Must be in shipping condition, and trimmed.
THE PATTERSON TILLEY Co., Hamilton, Ont.

WANTED AT SOUTH RIVER.

AN EXPERIENCED SHIPPER WHO UNDERSTANDS THE English export grades. Apply, THE TURNER LUMBER Co., LIMITED, Midland, Ont.

HEMLOCK AND PINE

WE ARE OPEN FOR STOCKS OF HEMLOCK and Pine. Lumber Department, GOLD MEDAL FURNITURE MFG. Co., Toronto.

SAW MILL IN VANCOUVER, ANNUAL turnover fifty thousand dollars, for sale; price twenty six thousand; terms can be arranged and fullest particulars given by THE LOCATORS, of Winnipeg, Manitoba.

TIMBER LIMITS — SPRUCE TIMBER limits in Manitoba for sale, in blocks from 10 to 60 million feet, to suit purchaser; exceedingly easily operated; close to railway; price \$2.00 per thousand feet. Box 221, CANADA LUMBERMAN, Toronto, Ont.

SAW MILL AND TIMBER LIMIT IN Manitoba for sale, yielding annual turnover of \$25,000. Price of Saw Mill, \$2,500, in four payments; limit 200,000 cords, \$10,000, \$5,000 cash, balance easy; teams, horses, sleighs, etc. THE LOCATORS, 62 and 63 Merchants Bank Building, Winnipeg, Manitoba.

TIMBER LIMIT FOR SALE IN BRITISH Columbia, eight square miles, fifty per cent. cedar, 25 per cent. fir and pine and 25 per cent. spruce. Limit situated on Columbia River with a frontage of ten miles; one hundred and twenty five million feet. Level ground. Full particulars on application to THE LOCATORS, Winnipeg, Manitoba.

A CANADIAN GENTLEMAN HAVING considerable experience in British methods and centres who intends sailing for Liverpool early in May would be pleased to represent a few Canadian firms in manufacturing or any mercantile or confidential capacity in the chief cities of Great Britain. All correspondence strictly confidential. Address B. F. P., care of CANADA LUMBERMAN, 38 Alliance Building, Montreal.

FOR SALE—A QUANTITY OF HEMLOCK and pine lumber. Write for prices. THE M. BEATTY Co., LIMITED, Pary Sound, Ont.

WANTED—ALL PULP MILLS AND PULP WOOD Companies to look up page 7 monthly issue, which is bound to interest you.

LUMBERMEN—YOUNG MAN WITH GOOD business and mechanical training from stump to lumber pile wants position. Will take junior place if ability ensures steady work and promotion. Address Box 220, c/o CANADA LUMBERMAN.

FOR SALE—150,000 FT. BEECH, 500,000 ft. hemlock. Can be cut to order. 200,000 ft. 1", 6/4", 8/4" and 3" soft elm, 200,000 ft. basswood, 20,000 ft. 4 x 4 cedar, 10 cars X.X.X. cedar shingles. Rail or water shipments. PEDWELL & LEMCKE, Lions Head, Ont.

SITUATION WANTED

YOUNG MAN EXPERIENCED IN THE English Timber Trade and West African Mahogany Trade, desires engagement. Apply Box 216, CANADA LUMBERMAN, Toronto, Ont.

SITUATION WANTED

YOUNG LADY, EXPERIENCED IN TYPE-WRITING and Shorthand, desires engagement. Apply Box 217, CANADA LUMBERMAN, Toronto, Ont.

CEDAR FOR SALE

10,000 PIECES ROUND CEDAR, 8-16 AND 25 feet long, on the Vermillion river. Can be delivered at Spanish boom. Also Cedar, Pine and Spruce lumber for sale here at Larchwood on C. P. R. JAMES MCCREARY.

WANTED.

POSITIONS AS MANAGER, ASSISTANT manager, bookkeeper or shipper, by two young men of ability and experience in lumber business. Good opening with Western or Pacific Coast concern preferred, and more of an object than large salary to start. Address C. & H., c/o CANADA LUMBERMAN, Toronto.

FOR SALE—WHITE PINE

CAR 1X12 AND UP, NO. 1, 2 AND 3 COM- I MON, 80% 1 1/2" and up, 1 car Basswood, all bone dry. JOHN M. SHAW, Forest, Ont.

FOR SALE

1" and 1 1/2" 1904 winter cut, mill run, trimmed Hard Maple.
1" 1904 winter cut, mill run, rough edged, Hard Maple.
1" 1905 winter cut, trimmed, all pure White Hard Maple.
1", 1 1/2" and 2" 1905 winter cut, mill run, trimmed Hard Maple.
Write for lists and prices. The W. R. THOMPSON Co., Teeswater, Ont.

FOR SALE—FOR IMMEDIATE SHIPMENT

Bone dry stock, one year and over cut and piled.

50,000 ft. 1" Soft Maple.
52,000 ft. 2", 3" and 4" Soft Maple.
75,000 ft. 1 1/2" and 2" Hard Maple.
42,000 ft. 1" Basswood.
33,000 ft. 1" Sycamore, (plain cut.)
12,000 ft. 1" and 2" Soft Elm.
8,000 ft. 1" and 2" Beech.
13,000 ft. 1 1/2", 1 3/4" and 2" Birch.

For prices and description apply to
LONDON LUMBER CO.
London, Ont.



PROVINCE OF QUEBEC.

Department of Lands, Mines and Fisheries.

WOODS AND FORESTS.

Quebec, 13th May, 1905.

Notice is hereby given that, conformably to sections 1334, 1335 and 1336 of the consolidated statutes of the province of Quebec, the timber limits hereinafter mentioned, at their estimated area, more or less, and in their present state, will be offered for sale at public auction, in the Department of Lands, Mines and Fisheries, in this city, on THURSDAY, 22nd day of JUNE next, at TEN o'clock A.M.

UPPER OTTAWA.

	Area Square Miles.
Bloc A.	
3rd range, 11	50
4th range, 10 to 14, each	50
" 15, North half	25
" 16, South half	25
" 17 to 19, each	50
" 20, North half	24 1/2
" 20, South half	27 1/2
5th range, 17 to 23, each	50
6th range, 20, North half	25
" 11, "	25
" 13, "	50
" 20 to 23, each	50
River du Lievre, N. W. branch, No. 7	50
" " " " " "	50
" " " " " "	50
" " " " " "	40
" " " " " "	30
River Ottawa, 607	22

SAINT MAURICE.

Manouan 1, north	50
" 2, north	24
" 3, north	35
" 1, south	50
" 2, south	50
" 3, south	45
" 8, south	30
" 9, south	21
Upper Saint Maurice, 9 to 14, each	50
" " 15	60
" " 16	38
" " 17 to 27, each	50
Upper Saint Maurice, 28	62
" " 29	35
" " 30	30
" " 31 to 34, each	50
River Croche, A	40
" B	34 1/2
" C	50
" D	37 1/2
" E	41
Rear River Trenche West	57
Lake a la Carpe	22

SAINT CHARLES.

River du Moulin 4	12
Rivers aux Ecorces and au Canot	39
River aux Ecorces, 5	29
" 6	41
River au Canot, 1	26
Grande Pikauba, 2	38
" 3	38
River Sainte Ann of Beaupre, 1	28
" " " 2	27
" " " 3	37

LAKE SAINT JOHN WEST.

River au Saumon, 1	46
" 2	49
" 3	41 1/2
" 4	68
" 5	91 1/2
Township Dablon, ranges 2 and 3	1 1/2
Township Ross, No. 1	8 1/2
" No. 4	15 1/2
River Ouatchouaniche, No. 1	11

LAKE SAINT JEAN EAST.

Township Kenogami, No. 2	1 1/2
--------------------------	-------

SAGUENAY.	
River Malbaie, 10.....	60
" 11.....	57
" 12.....	54
" 17.....	37
Bergeronnes, 1 East.....	25
River Sainte Marguerite, 87.....	24 1/2
River Manicouagan, 8 to 16, each.....	50
River Magpie, A.....	52
" B.....	42
River Natashquan, 1 to 4, each.....	50
River Piastre Bay, 1 to 8, each.....	25
Metapedia 2 ph. Cahot No. 2.....	11

RIMOUSKI EAST.	
River Cap-Chat, 1.....	47 1/2
" 2.....	45
" 3.....	45
River Matane, A.....	48

GRANVILLE.	
Township Parke, No. 4.....	4 1/2

GASPE WEST.	
River Sainte Anne, D.....	48
" E.....	43 1/2

GASPE EAST.	
Grand River Pabos, T.....	39

GASPE CENTRE.	
Sydenham West.....	20
River York, A.....	46 1/2
" B.....	52 3/4
" C.....	58 1/4
" D.....	58
" E.....	38 3/4
" F.....	33 3/4
" G.....	28
" H.....	27
" I.....	38
" J.....	23 1/2
" K.....	46
River Saint John, N.....	37 1/2
" O.....	42
" P.....	33
" Q.....	28 1/2

CONDITIONS OF SALE.

No limit will be adjudged at less than the minimum price fixed by the department. The limits will be adjudged to the highest bidder on payment of the purchase price, in cash or by cheque accepted by a duly incorporated bank. Failing payment, they will be immediately re-offered for sale. The annual ground rent of three dollars per mile, with fire tax, is also payable immediately. Those timber limits, when adjudged, will be subject to the provisions of all timber regulations now in force or which may be enacted hereafter. Plans of limits offered for sale are opened for inspection in the Department of Lands, Mines and Fisheries, in this city, and at the office of the Crown lands and timber agents in the different agencies in which said limits are situated, up to the day of sale. N.B.—No account for publication of this notice will be recognized if such publication has not been expressly authorized by the department. **ADELARD TURGEON,** Minister of Lands, Mines and Fisheries.

HAVE YOU ANY STOCK WHICH YOU wish to sell? If so, make the fact known to probable buyers by placing an advertisement in the Wanted and For Sale Department of this journal. Address, CANADA LUMBERMAN, Toronto.

he saw mills of the Oyamel Lumber Company at Roberval, Que., of which B. A. Scott is manager, were burned last week. The lumber yards were saved.

CURRENT TRADE CONDITIONS.

ONTARIO.

A superabundance of rain has been the only adverse condition affecting the movement of lumber during the past week, and as this is regarded as but a temporary influence, the firm tone of the market has not been impaired. The demand for finishing lumber is on the increase and promises to be quite large later in the season when the many buildings now under construction are nearing completion. The factory demand is not all that it might be, but this too will probably improve later when it is ascertained that the accumulation of the new cut will be light and that prices are not likely to decline. The manufacturers are now showing every confidence in a continuation of the present basis of white pine and hardwood values, while higher prices for hemlock have been suggested. It does not seem probable, however, that hemlock is likely to go much higher in the near future, as competition from the Michigan product is a factor which must be reckoned with in Western Ontario, for during the past week a cargo has been unloaded at Toronto for distribution to local yards. Apparently, hemlock can be purchased at the Michigan mills below \$12.

QUEBEC AND NEW BRUNSWICK.

There is a fair demand for nearly all sizes and grades of spruce lumber for local consumption and for shipment to the Eastern States, but uncertainty still characterizes the British business. The log drives on some of the streams are in safe waters, but on others a considerable quantity of logs has already been hung up. The recent difficulties at Van Buren in connection with the drives on the St. John river is a further source of uncertainty, but it is hoped that some arrangement will be reached by which the New Brunswick drives can be floated past the obstructions this year, as undoubtedly the dispute will be settled before next season. These conditions, however, have exerted a strengthening influence upon lumber prices, which are even firmer than they have been at any previous time this year. South American specifications have not been in as much demand of late, but it is believed

that the conditions causing this setback will be temporary.

New Brunswick cedar shingles are moving in average volume, but there have been no indications of higher prices in the immediate future. Extras are quoted at \$3.35 to \$3.40 for Boston delivery.

MANITOBA AND BRITISH COLUMBIA.

The past week has witnessed no great change in the condition of the lumber market of Western Canada. Prices are firm and perhaps a little higher than at this time last year, with a tendency to advance, though somewhat slowly. Dimension timber is moving fairly well, but there is not the usual call for the more expensive grades as yet. The prospects for a good crop in the Northwest are excellent and it is confidently expected that the demand for lumber during June and July will be sufficient to keep the mills busy. Fir and cedar are in good demand. Logs are fairly plentiful, and prices have a downward tendency. Good logs are worth \$7.50 per thousand feet at the mill, while rough logs bring from \$4.50 to \$5.00.

Inquiries have come from Japan for prices on some large building lumber, and with the prospect of an early termination of the war it is felt that considerable business will result.

UNITED STATES.

Shipments of lumber during the past week have been very heavy. Twenty-eight vessels arrived at Tonawanda, with a total of over 20,000,000 feet, which is 3,000,000 feet more than were recorded during the preceding and second largest week of the season. These receipts have been appreciated by the trade, as the demand is quite active and promises to provide a market for most of the lumber in sight. The eastern trade has been very satisfactory this season on account of the large volume of building operations. Figures on the lower grades, such as box and mill culls, have stiffened a little, but otherwise there is no change. The demand for hemlock is quieter in the Chicago district on account of labor difficulties, but as this promises to be one of the greatest building years in the history of that city, there is every prospect of an improved demand during the summer and fall

W. C. CRAWFORD

Tilbury Ont.
Manufacturer of . . .

Handles—Axe, Fork, Pick, Etc.

Also Hard and Soft Wood Heading and Red and White Oak, Maple and Elm Lumber.

Can supply Second Growth White or Red Oak squares up to 38 in. long in large quantities.

ARTHUR A. WATT
WIARTON, ONT.

Dealer in Hard and Soft Wood, Lumber, Lath, Shingles, Cedar Posts and Ties

SPECIAL—50,000 4/4, 3/4 and 1/2 Soft Elm 30,000 8/4 Maple, C & B.; 18,000 4/4 Soft Maple 100,000 4/4 M. R. Basswood; 18,000 4/4 Mill Run Pine Siding; 40,000 4/4 and 8/4 Birch; 40,000 6/4 Beech. Prices on application

Hunter, Crawford & Niebergall
(Successors to R. Watt)

LUMBER AND SQUARE TIMBER OF ALL KINDS
POSTS, POLES, TIES, LATH AND SHINGLES.

Bill Stuff a Specialty WIARTON, ONT.
Write Us for Hard and Soft Wood Slabs.

M. & L. Samuel, Benjamin & Co.

503 Temple Building, Toronto.

EXPORT DEPARTMENT.

Correspondence solicited with exporters of wooden goods, such as Sanitary Woodenware, Broom Handles, Fork and Shovel Handles, Turned Goods, etc. Payments made on receipt of Bill of Lading at Toronto. European House, SAMUEL SONS & BENJAMIN, 16 Philpot Lane, London, Eng.

A SPLENDID ROUTE.

The Wisconsin Central Railway is justly termed the "Sportman's Line" because it reaches into and through the very heart of the choicest hunting grounds in America.

The very best wild fowl shooting of the entire North is reached ONLY by this line. Hundreds of beautiful lakes abounding in wild rice and celery attracts myriads of ducks and geese and afford the finest kind of cover and the choicest shooting to be found the country over.

The Wisconsin Central Railway caters especially to the sporting public and during the various seasons for hunting and fishing furnishes daily information to its patrons as to local conditions anywhere along its lines upon application to the nearest ticket agent. It also arranges its train service with special reference to the convenience and comfort of sportsmen, and its employes are constantly on the alert to make travel over their lines pleasant and comfortable.

This line offers the best route between Chicago, St. Paul, Milwaukee, Minneapolis or to Lake Superior points via Ashland, Wisconsin.

Information given by addressing—

JAS. C. POND, Wis. Cent. R. R. Milwaukee.

WOODS & SPICER, Limited

.....MANUFACTURERS OF.....

BRITISH COLUMBIA RED CEDAR SHINGLES

Capacity 100 Million a Year.

We have had over 15 Years Experience, and are not Asking our Competitors for any Pointers as to Quality.

Wire Your Orders at OUR EXPENSE to Agents, or to us at VANCOUVER, B. C

KNIGHT BROTHERS CO. LIMITED Burk's Falls, Ont. **KILN-DRIED BIRCH FLOORING** Send for Catalogue * * * Samples by Mail KNIGHT BROTHERS CO LIMITED Burk's Falls.

Keenan Bros., Limited
Owen Sound, Ont.

HARDWOOD, HEMLOCK AND PINE LUMBER

We carry a full supply of native Hardwoods always on hand and solicit your inquiries. At the present time we have piled at outside points about 2,000,000 feet of Hardwoods, and about the same quantity of Hardwood, Hemlock and Pine piled here in Owen Sound, and we should be able to interest you if in the market.

WILL MAKE SPECIAL PRICES ON BROKEN LOTS AT OUTSIDE POINTS

Planing and Matching
—IN TRANSIT—
S. POMEROY, Orillia
PLANING, MATCHING, RESAWING,
SIDING, FLOORING, MOULDINGS
in Car Lots.
Factory near Station. Write for Prices.
Phone 113

MASON, GORDON & CO.
WHOLESALE TIMBER
Montreal, Quebec

Eastern Agents The B. C. Mills, Timber & Trading Co., Vancouver, B. C.
DOUGLAS FIR Timber in any size or length supplied
WRITE FOR PARTICULARS AND QUOTATIONS.

EVERYTHING IN LUMBER AND TIMBER
DRESSED AND IN THE ROUGH
BULMER, McLENNAN & COMPANY

MONTREAL QUE.
Office and Yard, 571 DORCHESTER ST. P.O. Box 1

months. The hardwoods are selling freely with no particular change in values to report. Plain oak, white ash and birch are among the best sellers. Maple flooring has gained some ground during the past month, and is now selling at prices which should give the manufacturer a fair margin of profit. Spruce is very strong, with wide cargoes offering for New York delivery on a basis of \$23, and 2-inch stock at \$20 to \$21. An increased scarcity of lath is reported. New York has recently bought very heavily at from \$3.50 to \$3.75, the latter figure being about the highest price ever paid in that market. Dealers at other points have refused to meet the competition and have therefore been unable to obtain an ample supply. There has been a slight decline from the high water mark, current values being about \$3.50 for 1 3/8 inch and \$3.35 for 1 1/2 inch.

GREAT BRITAIN.

British importers are still refusing to contract for stock at the prices asked by shippers, and this notwithstanding that stocks are getting very low. There has been some disappointment that conditions have not continued to improve and some are now disposed to take the view that the best that can be hoped for is an improvement upon the unsatisfactory trade of last year. The deal market is quite uncertain, but there continues to be a fair demand for battens. The fact that dealers are willing to purchase from one another from the stock on hand rather than place contracts for later delivery is an evidence of the lack of confidence which exists. First and second quality pine has been changing

hands in this way quite freely. The prizes realized at recent auction sales have also been satisfactory. So far as Canadian pine and spruce are concerned, the supply for the British market promises to be considerably lighter than usual, and it seems reasonable to expect that the present asking prices will be obtained later in the year if not almost immediately.

STOCKS AND PRICES.

The contract for 1,000,000 feet of timber to be used in the proposed Ogilvie elevator at Fort William, Ont., has been awarded to the Pigeon River Lumber Company.

D. G. Keyes, Secretary of the Department of the Interior, Ottawa, will receive tenders up to June 21st next for a license to cut timber on Berth No. 1229 containing 36 square miles and Berth No. 1230, both in the province of Manitoba.

Tugs of the Reid Wrecking Company, of Sarnia, arrived at Sandwich, Ont., on May 30th with the first raft of the season, for the Saginaw Lumber and Salt Company. There were 1,500,000 feet in the raft. The second part of the raft with an equal amount in the River St. Clair was expected down during the week. The tug Reid is now in Lake Huron with a raft containing 4,000,000 feet from Spanish River, for the Sarnia mill of the Cleveland Sarnia Sawmill Company.

THE NEW BRUNSWICK LOG DRIVES.

FREDERICTON, N.B., June 2, 1905.—The water in the rivers is low and some of the drives are already hung up. "There will

be 50,000,000 feet of logs on the Upper St. John waters which will not be brought out this spring," said a prominent lumberman. Of the 103,750,000 feet which it is estimated was to come out this year, a considerable proportion will have to wait over for another season unless there is a wonderful rise of water at an early day.

Reports received are to the effect that about 12,000,000 feet will be hung up on the Northwest Miramichi. The lumber that is tied up includes some for Ritchie, Hutchinson and Sinclair. The driving on the Southwest Branch has been most successful. Mr. Welsh's drive has already got as far as Boiestown, while T. Lynch's 10,000,000 has reached the islands about five miles below that place.

A number of men who were on Robert Aitken's drive on the Machias and Allegash streams, have returned. The drives are all in, and the Cunliffe drives, with which they amalgamated, all came out safely. Randolph & Baker have word to the effect that their drive on Chimenticook, with the exception of about 1,000 pieces, has been brought out safely. Joseph Hallett has got his drive out of Grand River. This drive consisted of about 2,000,000 feet of spruce for himself and about the same amount of cedar for the Van Buren Lumber Company.

John Kilburn, whose drives for W. H. Murray on the St. John headwaters had to be abandoned recently, has boomed the logs a short distance below English Bay, where they can easily be got out another season. Mr. Kilburn says that in his forty-four years' experience he never saw the conditions for driving so unfavorable as he found them this year.

Hilyard Bros.' drive on the Restigouche is safely out, but a number of small drives on the brooks owned by the different jobbers are hung up. The Richard concern have got out their main drive.

SALE OF QUEBEC TIMBER LIMITS.

A sale of timber limits is announced to take place at the Crown Lands Department, Quebec, on Thursday, June 22nd, 1905. Three thousand five hundred square miles of timber lands will be offered at upset prices to be fixed by the department. The limits to be sold are situated in the Upper Ottawa, the St. Maurice, St. Charles, Lake St. John East, Saguenay, Rimouski East, Metapedia, Granville, Gaspé East, Gaspé West and Gaspé Centre districts.

The Cleveland-Sarnia Saw Mills Co., Limited.

Manufacturers and Wholesale Dealers in

Timber, Lumber, Lath and White Pine Shingles

Special Bills Cut to Order in White Pine, Norway and Fir, any length from 10' to 60' long.

SARNIA, ONT.

J. B. Farwell & Son

CONTRACTORS AND DEALERS IN . .

Canadian Cedar Telegraph, Telephone and Electric Light Poles

Bancroft, Ont., and Oswego, N.Y.

FOR SALE

Exceptionally good Birch and Hemlock Lumber f.o.b. car South River Station. Mills at Midford (Eagle Lake,) Ont.

THE ROBB LUMBER CO., LIMITED
Guelph, Ont.

C. S. POWELL & CO.
Lumber Exporters

604 Temple Bldg., TORONTO and at NEW ORLEANS, LA.

To Millmen Cash buyers all kinds hardwoods. We solicit correspondence . . .

THE IMPERIAL LUMBER CO., LIMITED
SAW AND PLANING MILLS, WARREN, ONT.
RED AND WHITE PINE DEALS
All kinds of **SAWN LUMBER**
By Carload or Cargo.
Registered Cable Address: "Pinewood," "American Lumberman", Telecode.
BRANCH OFFICE, MANCHESTER, ENG.
Head Office, TORONTO, CAN.

SAGINAW LUMBER & SALT CO.
MANUFACTURERS OF
LUMBER AND SALT
Mills at Sandwich, Ont.
R. H. ROYS, Pres.
RALPH LOVELAND, Vice-Pres.
C. A. KENT, Sec'y.
R. S. ABBOTT, Treas.
SAGINAW, MICH.

CEDAR POLES
5,000 pieces, 10 to 20' long. Suitable for Hops, etc.
Price?—Well write us.
THE LONG LUMBER COMPANY
HAMILTON

JAS. LUNNY & CO.,
HINTONBURG, ONT.
DIMENSION TIMBER { In Spruce, White and Red Pine, up to 40 feet.
In Douglas Fir, up to 90 feet.
Every inquiry receives our Prompt attention.
Write for quotations. B. C. Cedar Shingles
SASH - DOORS - BLINDS

Herman H. Hettler Lumber Company
Manufacturers and Wholesalers of . .
WHITE and NORWAY PINE LUMBER LATH and SHINGLES
Shipments by Rail or Boat
MIDLAND, ONT.

J. D. SHIER LUMBER CO., LIMITED
BRACEBRIDGE, ONT.
MANUFACTURERS OF
LUMBER, LATH AND SHINGLES
Pine, Hardwood and Hemlock Floorings and Ceilings. Sash and Doors, Wood Turnings etc. All Dressed Lumber Kiln Dried if desired End Matched Flooring a Specialty.
GOOD PINE SIDINGS A SPECIALTY
Planing, Matching, Resawing, etc In Car Lots.
Manufacturer of Doors, Sash, Mouldings, Ceilings End-Matched and Bored **HARDWOOD FLOORING** A SPECIALTY.
Lumber Kiln Dried in Any Quantity.
J. R. EATON - Orillia, Ont.
Correspondence Solicited. Phone No. 54.

THE CHARLEMAGNE & LAG OUREAU LUMBER CO., LIMITED,
404 Coristine Building, MONTREAL, P. Q.
Mills at Charlemagne and Montcalm on Great Northern Railway.
SAWN AND DRESSED **LUMBER**
Clapboards, Shingles, Laths, Butter Boxes
Write us for quotations. Shipments by rail or water.

CACHE BAY LUMBER INDUSTRIES.
Geo. Gordon & Co.,
Manufacturers of RED and WHITE PINE
Band - Gang Circular **LUMBER** AND LATH
CACHE BAY, Ont.
C. P. R. 26 miles West North Bay

Cedar Cove Mill,
Vancouver, B.C.

E. H. HEAPS & CO.,

Vancouver, B. C.

Ruskin Mill
Ruskin, B. C.

Lumber, Lath, Shingles, Doors, Mouldings, Etc.

SPECIALTIES :

AA1 HIGH GRADE CEDAR SHINGLES.

Cedar Bevelled Siding, Cedar Door and Sash Stock, cut to size, Cedar Finish, Base, Casing, Newels, Balusters, etc. Douglas Fir Timber up to 85 feet in length.

W. J. SHEPPARD PRESIDENT
Waubaushe, Ont.

J. G. SCOTT, GENERAL MANAGER
Vancouver, B.C.

Pacific Coast Lumber Co.

LIMITED
VANCOUVER, B.C.
MANUFACTURERS OF

Fir, Cedar and Spruce Lumber, Lath, Mouldings, Turned Work, Etc. High Grade Red Cedar Shingles

Ontario Representative, W. J. LOVERING,

112 Mail Building, TORONTO

D. C. CAMERON, President and Manager.

WM. ROBERTSON, Secretary.

J. E. YOUNG, Cashier

The Rat Portage Lumber Co., Ltd.

Manufacturers
of

White and Red Pine Lumber, Lath, Shingles, Sash, Doors, Turned and Band Saw Work

Dealers in CEDAR POSTS, POLES and TAMARAC PILING

Mills at RAT PORTAGE and RAINY RIVER, Ontario, WINNIPEG, Manitoba, and VANCOUVER, British Columbia. Head Office: RAT PORTAGE, Ontario

Our Vancouver Mill cuts High-Grade Cedar, Fir, Spruce and Red Cedar Shingles. Winnipeg Mills cut Pine, Tamarac and Spruce Lumber
We also Manufacture all kinds of Mouldings, Sash, Doors, Turned Work and Boxes. Correspondence solicited at all four points.

THOS. KIRKPATRICK,

MANUFACTURER OF

Red Cedar Shingles

Daily Capacity,
250,000

Mills at Hastings and New Westminster

Head Office: Hastings, B.C.

Orders Solicited and Correspondence Promptly Attended to. Telephone B 1425
Ontario Representative: W. J. SMITH, Fergus.

J. D. SINGLAIR

Vancouver Cedar Mills

VANCOUVER
B.C.

FOR

High Grade

Cedar

Export Lumber & Shingle Co.

Wholesale Dealers

Limited

British Columbia Lumber and Shingles

The management of this company have had a lengthy experience in manufacturing and selling British Columbia Lumber and Shingles in Canada and the United States, and are well informed as to the requirements of the trade in those sections.

We are in a position to make prompt shipments at current market prices.

Correspondence and inquiries for prices and other information regarding British Columbia lumber conditions promptly answered.

YOUR TRADE RESPECTFULLY SOLICITED

Fee Block, 570 Granville Street, Rooms 3 and 4, Third Floor
Phone 2002

VANCOUVER - BRITISH COLUMBIA

Hazelmere Lumber Co.

HAZELMERE, B. C.

MANUFACTURERS OF

FIR, CEDAR and SPRUCE LUMBER CLEAR CEDAR AND FLOORING

Our Specialty.

Long Distance Telephone.

W. C. WELLS

PALLISER, B. C.

Manufacturer of

High Grade Spruce, Fir, Cedar and Lumber of all Descriptions.

CORRESPONDENCE SOLICITED.

CANADIAN MANUFACTURERS and WHOLESALERS

THE PEMBROKE LUMBER CO.
PEMBROKE, ONT.

We make a specialty of Dimension Stock in Pine, Spruce and Hemlock, and solicit your enquiries.

DELAPLANTE - McBURNEY LUMBER CO.,
WHOLESALE

White Pine, Hemlock, Lath, Shingles

Stocks in at { Collingwood Powassan Cartier Callander
Ontario at { Midland Whitney Sturgeon Falls North Bay

TORONTO OFFICE: Room 503 Manning Chambers.

Office, Yards and Docks, NORTH TONAWANDA, N. Y. Send us your enquiries

FOR Pine, Hemlock, or Hardwood, Lumber and Timber, Telegraph Poles, Ties, Posts, Lath, Shingles, Dressed Lumber, Sash, Doors, Interior Finish, End Matched and Bored Hardwood Flooring, etc., try

JOHN HARRISON & SONS COMPANY, LIMITED

We have a complete stock, two Saw Mills running in summer and one all winter. HEAD OFFICE, SAW AND PLANING MILLS, OWEN SOUND, ONT.

RHODES, CURRY & CO., Limited
LUMBER MERCHANTS.

Yards at Amherst, Little Forks, Sydney and Halifax. BUILDING MATERIAL of all kinds carried in stock. We are buyers of Ontario Basswood, Elm and Pine.

Amherst, N.S.

Sawn and Hewn Spruce, Hemlock, Pine and Birch Timber, Spruce and Pine Boards and Plank, Birch and Ash Boards and Plank, Flooring, Shingles, etc.

JAMES J. MURPHY, Bank of Hochelaga Building **QUEBEC**

The Cook & Bros. Lumber Co.

Of Ontario, Limited
MILLS at SPRAGGE, Algoma Dist., Ont.
on "Soo" Branch C.P.R.

OFFICES { Manning Arcade, Toronto
Coristine Building, Montreal
And at Mills at Spragge.

MANUFACTURERS OF

White and Red Pine
Lumber and Lath

Water Shipments

THE M. BRENNEN & SONS MANUFACTURING CO., LIMITED

Saw Mills at RAINY LAKE, Ontario. Planing Mill and Head Office: HAMILTON, Ontario.

THE NIPISSING LUMBER COMPANY, LIMITED

Mills at CACHE BAY and SPANISH RIVER, Ontario.

Manufacturers of and Wholesale Dealers in all kinds of LUMBER AND LATH

Both Railway Delivery and Water Shipments. Correspondence Solicited. The NIPISSING LUMBER CO., Limited Head Office: HAMILTON ONT.

AUGER & SON - Quebec
PULP WOOD AND TIES

Bought at Any Station.

Also Dimension Timber, Sawn to Sizes, Telegraph Poles and Lumber.—Write Us.

A. F. BURY AUSTIN
WHOLESALE LUMBER and TIMBER
CANADA PINE

Bank of Ottawa Building, 224 St. James St., - MONTREAL, CANADA
SPECIALTIES: Railway Bridge Timber and all kinds of Hardwoods; Ship Decking, Norway and White Pine, Dimension Timber, Norway Car Sills, Car Flooring, Telegraph Poles, Railway Ties, Oak and Whitewood, Planed and Rough Lumber, British Columbia Pine, Southern Pine, &c.; Birch Flooring, hollow back, end butted.

Eastern Agent for The Pacific Coast Lumber Company, Limited, Vancouver, B. C.
Douglas Fir Timber in any size or length up to 90 feet long. Timber Planers face up to 24 inch x 30 inch. Dry Kilns of large capacity. Rough and Dressed Lumber, Douglas Fir and Cedar.

WRITE FOR PARTICULARS AND QUOTATIONS.

R. LAIDLAW LUMBER CO.

18 Toronto Street, Toronto

JAS. PLAYFAIR.

D. L. WHITE.

PLAYFAIR & WHITE

Manufacturers and Wholesale Dealers

LUMBER • LATH • SHINGLES

Contractors for Railway Supplies
BILL TIMBER a Specialty

MIDLAND, ONT

A. & P. WHITE

Manufacturers of and Dealers in

Sawn and Planed Lumber, Dimension Timber. Joisting. Car Sills, Car Flooring, Shingles and Lath

PEMBROKE ONT.

GET YOUR LUMBER AND TIMBER FROM

PINE LUMBER COMPANY

(On C. P. R. Main line near Sudbury)

PINE, ONT.

F. MCGIBBON & SONS,

PENETANQUISHENE ONT.

Manufacturers of Pine, Hemlock and Hardwood Lumber, and dealers in Cordwood Hemlock Bills cut on short notice.

MAITLAND, RIXON & CO.

OWEN SOUND, ONTARIO.

Manufacturers and Dealers

LUMBER LATH, TIES, POLES, SHINGLES, ETC.

Make a Specialty of Long Pine, Cedar and Hemlock Bill Stuff. We ship by C. P. R., G. T. R., and by Water.

Turner Lumber Co., Limited
MANUFACTURERS

LUMBER and LATH

Shipments by Rail or Water. • Midland, Ont.

HARDWOOD FLOORING

End Matched, Bored, Steel Polished, and Bundled

Send for Price List

A few cars of selected Maple and Birch and other Hardwoods at close price

THE SEAMAN KENT CO., Limited

160 Bay St. Toronto Factory, Meaford, Ont.

THE FOSS LUMBER COMPANY

WHOLESALE

BRITISH COLUMBIA FIR, SPRUCE AND

CEDAR LUMBER, RED CEDAR SHINGLES

We Solicit Your Inquiries.

J. F. FOSS, Manager. 624-625 Union Bank, Winnipeg, Man.

CEDAR LUMBER AND POLES FOR SALE

I can saw out to your order, during the winter months, bills in heavy square Cedar, or Planks.

Have also for sale a few cars of Poles from 25 to 50 ft.

Correspondence Solicited.

J. S. FINDLAY,

OWEN SOUND ONT.

CANADIAN LUMBER SHIPMENTS.

From Halifax, N.S.; Steamer Dahome, for British West Indies, 64,941 ft. spruce boards, value \$948, by Pickford & Black, agents. Schooner Robert Ewing, for Cuba, 423,845 ft. pine lumber, value \$6,359. Steamer Laurentian, for Glasgow, 28,256 ft. birch deals, value \$311; 213,055 ft. spruce deals, value \$2,769, by Furness, Withy & Co., agents. Steamer London City, for London, 241,755 ft. birch deals, value \$2,659; 122,067 ft. spruce deals, value \$1,586, by Furness, Withy & Co., agents.

From St. John, N.B.: Steamer Ocamo, for Bermuda, 12,500 cedar shingles, by J. Roderick & Son; 20,000 laths, 10,000 sup. ft. lumber, by Andre Cushing & Co. Schooner Jennie C, for Boston, 30,024 ft. plank, 7,239 ft. scantling, 1,106,000 cedar shingles, 50,000 spruce shingles. Schooner Romeo, for Boston, 7968 ft. scantling, 149,767 ft. plank. Schooner Roger Drury, for Providence, R.I., 1,900,000 laths. Steamer Pine Branch, for Belfast, 1,239,442 ft. deals, 59,474 ft. scantling, 18,285 ft. ends. Schooner Pardon C. Thompson, for Boston, 71,035 ft. boards, 114,194 ft. plank. Schooner Priscilla, for Providence, R.I., 122,462 ft. plank, 44,222 ft. scantling.

From Montreal: Steamer Virginian, for Liverpool, 6,593 pcs. deals, by W. & J. Sharples; 8,239 pcs. deals and boards, by Watson & Todd. Steamer Canada, for Liverpool, 12,951 pcs. deals, by Watson & Todd; 88 logs, by McLaurin Bros.; 10,775 pcs. deals, by W. & J. Sharples, 4,214 pcs. deals, by Charlemagne Lumbe; Co. Steamer Milwaukee, for Liverpool 67 logs, 67 pcs. timber, 1,517 pcs. deals by J. Burstall & Co.; 12,385 bdls. lumber, 18,466 pcs. lumber; 214 pcs. timber, 480 logs, 16,341 maple squares, 4,877 bdls. shooks, by Canadian Pacific Railway. Steamer Montezuma, for London and Antwerp, 2,861 bdls. lumber, 351 pcs. lumber, 998 bdls. staves, 21,676 bdls. shooks, 20 logs, 1,175 bdls. flooring, by the Canadian Pacific Railway; 1,280 pcs. boards, by Charlemagne Lumbe Co.; 3,994 pcs. deals, by McArthur Export Co.; 193 logs,

by Dobell, Beckett & Co.; 88 logs, by W. & J. Sharples; 90 logs by McLaurin Bros. Steamer Pomeranian, for London and Havre, 6,042 pcs. deals, by Watson & Todd; 1,000 pcs. deals, by E. Parizeau. Steamer Iona, for London, 84 logs, by McArthur Export Co., 611 bags squares, by Grand Trunk Railway. Steamer Manxman, for Bristol, 4,328 pcs. deals, by R. Cox & Co.; 99 logs, by McArthur Bros. Steamer Sicilian, for Glasgow, 106 logs, by Canadian Pacific Railway; 7,302 pcs. deals, by E. H. Lemay; 2,018 pcs. deals, by W. & J. Sharples; 84 logs, by McArthur Export Co. Steamer Athenia, for Glasgow, 2,413 pcs. deals, 19 logs, 1,421 pcs. lumber, by Grand Trunk Railway; 136 logs, by McArthur Export Co.; 73 logs, 1,715 pcs. deals, by J. Burstall & Co.; 96 logs, 11,357 pcs. deals, by Dobell, Beckett & Co.; 5,607 pcs. deals, by W. & J. Sharples; 1,767 pcs. boards, by R. Cox & Co. Lord Lansdowne, for Cardiff, 13,292 pcs. deals, 58 logs, by J. Burstall & Co.; 5,203 pcs. deals, by McArthur Export Co.; 3,853 pcs. deals, by Dobell, Beckett & Co.; 13,286 pcs. deals, by Charlemagne Lumbe Co. Steamer Escalona, for Aberdeen and Newcastle, 3,786 pcs. deals, by Watson & Todd; 2,850 pcs. deals, 153 logs, by Dobell, Beckett & Co.; 1,142 pcs. boards, by Watson & Todd; 2,309 pcs. boards, by J. Burstall & Co. Steamer Glenarm Head, for Dublin, 1,028 pcs. deals and boards, by R. Cox Co.; 1,731 pcs. deals, 34 pcs. birch, by W. & J. Sharples; 1,432 pcs. deals, by McLaurin Bros.; 903 pcs. deals, 14,250 pcs. ends, by Dobell, Beckett & Co. Steamer Wyandotte, for Durban, South Africa, 10,563 pcs. lumber; 250 bdls. lumber, by American Trading Co.; 2,300 pcs. lumber, 20 bdls. doors, by Crossman & Seilcken; 1,440 pcs. lumber, by H. W. Peabody Co.; for Cape Town, 11,069 pcs. lumber, by H. W. Peabody; 1,776 pcs. lumber, by American Trading Co.; 2,506 pcs. lumber, by G. Amsinck & Co.; for Algoa Bay, 217 pcs. lumber, by Thomson & Co.; 130 bdls. doors, by Crossman & Seilcken. Steamer Ottoman, for Liverpool, 1,425 pcs. boards.

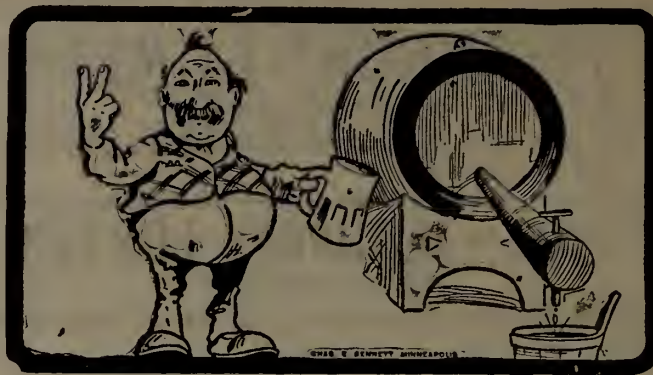

WE'LL TREAT YOU RIGHT

That's what you want, of course —

And that is why we are expecting an order from you for some of that fine stock of **SPRUCE LUMBER** which you have heard so much about.

It is good stuff, and we will give you good service and fill your order promptly.

The Red Deer Lumber Company
WINNIPEG, MAN.

UNITED STATES MANUFACTURERS AND WHOLESALERS

YOU
CAN
REACH

THE BONSAK LUMBER CO.
WHOLESALE HARDWOODS

ST. LOUIS
BY
RAIL, MAIL
WIRE OR
'PHONE

MCGLOURE LUMBER CO.

Wholesale Dealers in . . .

Hardwood Lumber

Carry in Stock and Have for Sale

ASH, BASSWOOD, BEECH, BIRCH, BUTTERNUT, CHERRY, CHESTNUT, COTTONWOOD, CYPRESS, ELM, GUM, HICKORY, MAHOGANY, MAPLE, OAK, POPLAR, SYCAMORE, WALNUT, POLES (Oak, Hickory and Ash), RIMS and SPOKES (Oak and Hickory), OAK BENDING PLANK, OAK BILL STUFF, RAILWAY TIES.

Office and Yards: 520 to 530 Franklin St., DETROIT, MICH.

Correspondence Invited on All Hardwoods.

H. D. WIGGIN BOSTON, MASS.
89 STATE ST.

will inspect at mill and PAY CASH for

LOG RUN

Elm, Ash, Bass and other Hardwood

CORRESPONDENCE SOLICITED.

YELLOW PINE

We are in position to give first - class stock. Reasonable prices. Prompt shipments. Mills in Alabama, Mississippi and Arkansas.

MANN, WATSON & CO. Muskegon, Mich

HAEBERLE LUMBER CO.

Wholesale and Retail Dealer in

YELLOW PINE and OAK TIMBER

Large stock of Timbers and Bill Stuff carried in stock.
All sizes and lengths for immediate delivery.

Telephone No. 10

Cedar Street, NIAGARA FALLS, N.Y.

THE ROBERT H. JENKS LUMBER CO.
CLEVELAND, OHIO

MANUFACTURERS AND WHOLESALERS OF

YELLOW PINE, POPLAR, HEMLOCK AND HARDWOODS

Yellow Pine Timbers a Specialty

Indiana Lumber & Veneer Co.
INDIANAPOLIS, IND.

Sawed and Sliced Quartered
Oak a Specialty

Correspondence Solicited. <<<<<

† **Veneers**

FRANK G. BURY

BURY & NOBLE

MASON A. NOBLE

WHOLESALE

LUMBER - DETROIT

MICHIGAN

Send us your inquiries for Southern Yellow Pine.

NEW BRUNSWICK LETTER.

Correspondence of the CANADA LUMBERMAN.)

ST. JOHN, N.B., May 31st, 1905.—The demand for lumber of all kinds continues in a way that is very gratifying to all those who have or will have some to sell. So far as the selling is concerned all indications point to a remarkably satisfactory season. Apparently the only misgiving on the part of the manufacturers of this section is in regard to the log drives. Until a few days ago it was felt that, while large quantities would hang up, yet most of the mills would have enough available to make almost an average sawing season. Now, with the difficulty

which has arisen at Van Buren, the outlook is full of uncertainty.

In the American market trade continues remarkably strong, especially for deals. Values are well maintained in this latter line; local quotations having a tendency toward higher figures.

Stocks of American deals are light; 2,000,000 s. ft. would easily cover the whole. Judging from the purchases of American logs made at earlier dates for delivery during 1905, the cut of American lumber of all kinds will be lighter this year than usual at this port.

A feature of the American market just now is the slackness in demand for spruce 3 x 9; this in spite of the fact that a tremendous business is being done in other lines.

American spruce deals are quoted at

this date, f.o.b. St. John, as follows: 3 x 10 and 12, \$17.50 to \$18.50; 3 x 9, \$16; 3 x 7 and 8, \$13.50 to \$14.

The demand for cedar shingles in the United States is not so snappy as it usually is at this time of the year, although it is very uniform and the volume of sales fairly large. Prices are at least being maintained and in some cases the figures mentioned last month have been improved upon, but speaking generally it cannot be said there has been an advance in price.

Quotations now being made on cedar shingles (non-dutiable) f.o.b. St. John are as follows: Extra, \$2.95; clear, \$2.45; 2nd clear, \$1.90; No. 1, 95 cents.

Spruce lath are in good demand at the following figures, f.o.b. St. John, for immediate delivery: Non-dutiable, \$2.55; dutiable, \$2.30.

Shipments to the Eastern States in all

lines have been very light, which condition is due to a remarkable scarcity of tonnage, which is also the case in all ports along the coast. During the last fortnight great difficulty has been experienced in obtaining a vessel of any kind.

The few charters that have been made were at the following figures: Long lumber to Boston, \$2.50 per M s. ft.; to the Sound, \$2.75; to New York City, \$3.

Cable address: "Dundonian, Dundee."

BERG & SON,

Timber and Wood Pulp Agents and Brokers

DUNDEE, SCOTLAND

Contracts made between Shippers and Importers
Correspondence solicited

BRITISH WOOD BROKERS AND IMPORTERS

FARNWORTH & JARDINE

Wood Brokers and Measurers

Cable Address "Farnworth," Liverpool. 3 Dale St., 71 Regent Road **BOOTLE LIVERPOOL, ENG.**

F. A. Lightbody & Co.

8 Gordon Street - GLASGOW, SCOTLAND

WOOD BROKERS

Cable Address: "TENEBRIS," GLASGOW. Codes: A. B. C., A 1, "Zebra" and Private.

Agents for **CANADIAN WHITE PINE AND SPRUCE; Hardwoods in Log, Etc.**
Shipments handled to the best advantage to all ports in the United Kingdom. Correspondence Solicited.

LOUIS BAMBERGER, 2 Broad Street Building, LONDON, E. C.

IMPORTER OF ———— Telegraphic Address "Bellywood, London."

Pine, Spruce and all Canadian Wood Goods

Are Open to Contract for *Glued-Up BASSWOOD KEYBOARDS*

ZEBRA CODE A. B. C. CODE DIRECTORY CODE

GELLIBRAND, HEYWOOD & CO.

Wood Agents and Brokers

Cable Address: "GELLICHT," LONDON 57 Gracechurch St. London, E.C. England

SMITH & TYRER - 14 Tithebarn Street, LIVERPOOL

.. WOOD AGENTS ..

Cable Address—"Walmer," Liverpool.

Halifax, N.S., Office—SMITH, TYRER & Co., Metropole Bldg., Hollis St. Halifax, N.S.

Edmiston & Mitchells
TIMBER BROKERS

Cable Address: "EDMISTON" Glasgow. 33 Renfield Street, GLASGOW

GANT & KEMP  **TIMBER BROKERS**

52 St. Enoch Square, GLASGOW

Cable Address: "TECTONA" Glasgow.
A 1 and A B C Codes used.

Every lumberman wants it **35 cents buys it**

Scribner's Lumber and Log Book

BRIMFUL OF EVERY-DAY PRACTICAL INFORMATION Address: THE CANADA LUMBERMAN, Toronto

CABLES, DOORCHECK LONDON

We are Buyers of Pine Doors and Mouldings, Electric Wire Casings, W.C. Seats, Wooden Mantel Pieces, Sashes and Frames, and all kinds of ready made joinery.

LONDON STORES: Locke's Wharf, Edmonton, N.

STAVERS & STAVERS

OFFICES: 158, Leadenhall Street, London, E.C.

Manufacturers and Importers of JOINERY

FELBER, JUCKER & CO.

Lumber Importers

MANCHESTER ENGLAND

Invite offers from Lumbermen for . . . Spruce Deals and Battens, Spruce and Pine Floorings, Shooks, Sashes, Mouldings, Dowels, Broom Handles, Chair Stock, Seats, etc., or any Woods Suitable for English Market.

Telegraphic Address: FELBER MANCHESTER.

ASHTO & PETFORD

BISHOP LANE, - HULL, ENGLAND

BUYERS OF BOX SHOOKS

Invite correspondence from manufacturers who are in a position to export to Great Britain.

Cable address, "Shooks," Hull.
Codes—A. B. C. 4th Edition and Zebra.

JOSEPH OWEN & SONS, LTD.

Timber Importers

Cable Address "Owen Liverpool" Liverpool, Eng.

BUYERS OF

White Ash Logs and Planks.
Oak Logs and Planks.
Rock Maple Logs and Planks.
Rock Elm Logs.
Hickory Logs.

... ALSO ...
All classes of Lumber and Manufactured Wood Goods suitable for the English Market.

JAMES WEBSTER & BROTHER

BOOTLE, LIVERPOOL, ENGLAND

TIMBER MERCHANTS

BUYERS OF Oak, Birch, Ash, Grey Elm Logs and Lumber, Elm Staves and Heading, Handles of all descriptions
Veneers A Specialty

ALFRED DOBELL & COMPANY

WOOD AGENTS AND BROKERS

Liverpool and London Chambers - LIVERPOOL, ENGLAND

CABLE ADDRESS "DOBLE LIVERPOOL."

THOMPSON, BLOIS & KJELLGREN

ALL KINDS OF LUMBER AND LOGS

CASH ADVANCES MADE AGAINST SHIPPING DOCUMENTS . . .

BRANCH OFFICES: 41 Corporation St., MANCHESTER
Waterloo Chambers. GLASGOW

HEAD OFFICE: 17 Gracechurch St., LONDON, E.C.

BRANCH OFFICE: Brook 1, HAMBURG

THE ONTARIO LUMBER CO. LIMITED

MILLS: North Bay, C.P.R. and G.T.R. Delivery.

MANUFACTURERS WHITE PINE LUMBER, LATH AND SHINGLES.

35 and 36 Home Life Building TORONTO, Ont. Mills: French River, Georgian Bay Water Shipment Only.

GEO. G. GLADMAN MANUFACTURER OF WHITE PINE AND HEMLOCK LUMBER LATH AND SHINGLES

Mills at Smith's Bay Township of Carling

PARRY SOUND, ONT.

CORRESPONDENCE SOLICITED

PEDWELL & LEMCKE, Lions Head, Ontario

MANUFACTURERS OF Pine, Hemlock and Hardwood Lumber, Shingles, Ties, Poles, Posts, Etc. Rail or Water Shipments. Correspondence Solicited.

WE have Three Millions of Hemlock, running in lengths from 10 to 24 feet, which we are prepared to cut in blocks of 50,000 feet or over.

THE WOODSTOCK LUMBER & MANUFACTURING CO.

Dealers in Pine, Hemlock and Hardwood Lumber..

WOODSTOCK, ONTARIO

CANADIAN LUMBER WANTED

We solicit consignments of long and short lumber from the Maritime Provinces and are prepared to purchase White Pine and Hardwoods in Ontario and Quebec.

ADDRESS:

CHAS. S. WENTWORTH & CO. Room 510, 147 Milk St. - BOSTON, MASS.

THE KING AND BARTLES LUMBER CO. PINE, POPLAR AND HARDWOODS

HEADQUARTERS HARDWOOD Citizens' Building, Cleveland, O. Distributing Yard McMinnville, Tenn. We buy and sell Pine in Car and Cargo Lots

McLennan Timber Land and Lumber Co., Limited

Selling Agency and Dealers in all kinds of Timber Lands. Offices: Quebec, 131 St. Peter St. Ottawa, Room 9, Central Chambers.

A. P. EBERT

MANUFACTURER OF AND DEALER IN Pine and Hardwood Lumber, Lath, Shingles, Posts, Broom Handles, and Short Hardwood Dimension Stock WARTON, ONT.



THE NEW LINE

Through the Spruce Forests of the Laurentian Mountains-between Quebec and Hawkesbury. WATER-POWERS, TIMBER LIMITS AND ELECTRIC POWER FOR SALE. IDEAL PULP-MILL SITES. Unexcelled Export Facilities at Quebec. A. J. GORRIE, General Supt. MONTREAL GUY TOMBS G. F. & P. A.

CURRENT LUMBER PRICES--WHOLESALE

TORONTO, ONT.

CAR OR CARGO LOTS.

Table listing lumber prices for Toronto, Ontario, including items like 1 inch No. 1 Pine, 1 1/2 inch No. 2 Pine, etc.

HARDWOODS--PER M. FEET CAR LOTS.

Table listing hardwood prices per m. feet car lots, including items like Ash White, 1 to 2 in, Birch M. R., etc.

QUEBEC, QUE.

WHITE PINE--IN THE RAFT

Table listing white pine prices in the raft for Quebec, Quebec, including items like Square white pine, measured off, etc.

RED PINE--IN THE RAFT.

Table listing red pine prices in the raft for Quebec, Quebec, including items like M. assured off, according to average and quality, etc.

OAK--MICHIGAN AND OHIO.

Table listing oak prices for Michigan and Ohio, including items like Elm, soft, mill, etc.

ELM.

Table listing elm prices, including items like 10 inches and up, according to average and quality, etc.

ASH.

Table listing ash prices, including items like 14 Inch, 16, 17, etc.

BIRCH.

Table listing birch prices, including items like 14 Inch, 16, 17, etc.

OTTAWA, ONT.

MANUFACTURERS' PRICES.

Table listing manufacturers' prices for Ottawa, Ontario, including items like Pine, 2nd sidings, etc.

Table listing lumber prices for Toronto, Ontario, including items like Pine good strips, Pine good shorts, etc.

BAY CITY AND SAGINAW, MICH.

UPPER AND SELECTS.

Table listing lumber prices for Bay City and Saginaw, Michigan, including items like Uppers, 1 in., 10 in. and up, etc.

FINE COMMON.

Table listing lumber prices for Bay City and Saginaw, Michigan, including items like 1 in., 8 in. and up wide, etc.

NO. 1 CUTTING.

Table listing lumber prices for Bay City and Saginaw, Michigan, including items like 2 1/2 and 3 in., 8 in. and up wide, etc.

STRIPS, A AND B (CLEAR AND SELECTS).

Table listing lumber prices for Bay City and Saginaw, Michigan, including items like 1 1/2 in., 4, 5 and 7 in. wide, etc.

FINE COMMON OR C.

Table listing lumber prices for Bay City and Saginaw, Michigan, including items like 1 1/2 in., 4, 5 in. wide, etc.

SELECTED NO. 1 SHELVING OR FENCING STRIPS.

Table listing lumber prices for Bay City and Saginaw, Michigan, including items like 1 1/2 in., 4, 5, 6 in. wide, etc.

BARN BOARDS OR STOCKS.

Table listing lumber prices for Bay City and Saginaw, Michigan, including items like No. 1, 12 in., etc.

SHIPPING CULLS OR BOX.

Table listing lumber prices for Bay City and Saginaw, Michigan, including items like 1 in., 4 and 5 in. wide, etc.

SHAKY CLEAR.

Table listing lumber prices for Bay City and Saginaw, Michigan, including items like 1 in., 10 in. and up wide, etc.

SHINGLES, 18-IN.

Table listing lumber prices for Bay City and Saginaw, Michigan, including items like Pine, XXXX, etc.

LATH.

Table listing lumber prices for Bay City and Saginaw, Michigan, including items like No. 1 White Pine, etc.

ALBANY, N.Y.

PINE.

Table listing lumber prices for Albany, New York, including items like Uppers, 3 in., etc.

SHINGLES, 18-IN.

Table listing lumber prices for Albany, New York, including items like No. 1 White Pine, etc.

Table listing lumber prices for Buffalo and Tonawanda, New York, including items like Pine, Spruce, etc.

BUFFALO AND TONAWANDA, N.Y.

WHITE PINE.

Table listing lumber prices for Buffalo and Tonawanda, New York, including items like Uppers, 1, 1 1/2, 2 in., etc.

The following quotations on hardwoods represent the jobber's buying price at Buffalo and Tonawanda:

WHITE ASH.

Table listing lumber prices for Buffalo and Tonawanda, New York, including items like 1st & 2nd, 1 inch, etc.

BLACK AND BROWN ASH.

Table listing lumber prices for Buffalo and Tonawanda, New York, including items like 1st & 2nd, 6 inch np, etc.

ELM.

Table listing lumber prices for Buffalo and Tonawanda, New York, including items like 1st & 2nd, rock, 6 in np, etc.

MAPLE.

Table listing lumber prices for Buffalo and Tonawanda, New York, including items like 1st & 2nd hard, etc.

BOSTON, MASS.

Table listing lumber prices for Boston, Massachusetts, including items like White Pine Uppers, 1 to 2 inch, etc.

NEW BRUNSWICK CEDAR SHINGLES.

Table listing lumber prices for Boston, Massachusetts, including items like Extras, etc.

BRITISH COLUMBIA SHINGLES.

Table listing lumber prices for Boston, Massachusetts, including items like Red Cedar Extras, etc.

THE LATE THOMAS MACKIE.

Mr. Thomas Mackie, ex.-M.P., died at his residence in Pembroke, Ont., on May 21st last, of apoplexy. He had been slightly indisposed for some weeks, but was not confined to his house and no serious result was anticipated. The end came suddenly, however, before medical assistance could be obtained.

Mr. Mackie was born in the city of Ottawa in the year 1838, of Scotch parentage. In early life he took to lumbering operations. His first venture was on the Bonnechere river. Then he bought the O'Kelly limits on the Indian river and afterwards went into partnership with Mr. A. Barnet, of Renfrew, operating on the Petawawa river. This partnership continued until seven years ago, since which time he has carried on the business himself, with the assistance of his sons.

Mr. Mackie's lumbering operations were quite extensive but were confined largely to



THE LATE THOMAS MACKIE.

square timber for export to Great Britain. At the Government sale of limits in December, 1903, he bought 3¼ square miles in the Township of Hamel and two berths in Merrick Township. For the former he paid \$31,500 per square mile, the highest price ever given for a timber limit in Canada. He knew well the value of the property, however, which lay in the large quantity of excellent board timber to be obtained therefrom. Besides lumbering, he had a large cattle ranch in Alberta.

Mr. Mackie commenced his parliamentary career by defeating Hon. Peter White, also a prominent lumberman, in 1896, and again in 1900, but the latter gentleman defeated Mr. Mackie in the Dominion elections last year. He was one of the stalwarts of the Liberal party, and although not often heard on the floor of the House, was very attentive to the wants of his constituents.

Personally Mr. Mackie was a great favorite with all classes of the community. He was warm hearted and genial and made many friends. He was married in 1872 to Miss Jessie Shaw, of Lake Dore, who survives him, along with five sons.

Mr. Mackie left an estate estimated at \$800,000.

THE MONTREAL LUMBER ASSOCIATION.

We are pleased to be permitted to present the portraits of some of the officers of the recently-organized Lumber Association of the Montreal Board of Trade. The president, Mr. J. T. Marchand, is the president of J. T. Marchand & Company, Limited, who are large dealers and exporters of lumber. Mr. E. M. Nicholson, the vice-president, is the manager for



MR. J. T. MARCHAND, President.



MR. E. M. NICHOLSON, Vice-President.



MR. STANLEY BARKER, Treasurer.

OFFICERS OF THE LUMBER ASSOCIATION OF THE MONTREAL BOARD OF TRADE.

the McArthur Export Company, while Mr. Stanley Baker, treasurer, is the local manager for Robert Cox & Company, both of the latter concerns being important factors in the export trade. The secretary of the association is Mr. Cook, assistant secretary of the Board of Trade.

Although organized but a short time, we understand that the membership is growing quite rapidly and promises to soon include practically all the lumbermen in the Montreal district.

THE MCKAM PATENT TOOTH SAW.

The demand for a saw that would cut a sufficiently smooth point or edge to avoid the necessity of planing is believed to have been satisfactorily met in the new McKam patent tooth circular saw. It does equally good work in cross-cutting, ripping or mitring. This style of saw is very desirable for use in planing mills,

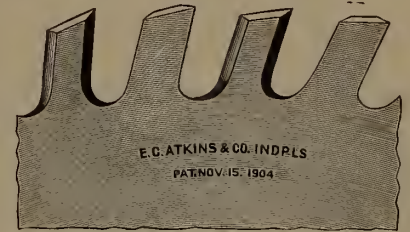

MCKAM PATENT TOOTH.

furniture moulding and picture frame factories and pattern shops, as the character of the work done by it is so smooth that a glue joint can be made without sanding.

The McKam patent tooth circular saw is manufactured exclusively by E. C. Atkins & Company, Inc., Indianapolis, Ind.

DISPOSAL OF REFUSE.

The Gordon Hollow Blast Grate Company, of Greenville, Mich., have sent us the following remarks touching the important question of the disposal of sawdust and refuse:

From time immemorial different forced draft systems have been used. Nothing practical was ever devised for sawdust and wood refuse, however, until in 1889, when the Gordon Hollow Blast Grate was put on the market. The favor with which it was instantly received, and the extent to which it has met and even exceeded all expectations, was and is remarkable. The explanation lies in the fact that it was the first practical method of applying a blast that had ever been evolved. Other systems had provided for the introduction of a blast, but at the wrong point, or under unfavorable conditions. One way was to blow into the ashpit. This was objectionable because (1) it cut off the natural draft entirely, throwing all the work on the blower; (2) there was nothing to prevent the blast from pursuing its natural tendency to seek the path of least resistance, so that the bulk of it passed through the grate, where it was bare, thereby cooling the furnace instead of promoting combustion; and (3) it caused the grate to burn out very rapidly. All of these very serious faults the Gordon Hollow Blast Grate effectually overcame; whence its favorable reception.

Another unsuccessful attempt to promote combustion lay in the construction of a hollow bridge wall. While this proved to some degree effective with soft coal under certain conditions, it was a dismal failure with sawdust, and could not be otherwise, because (a) it produced the same effect as opening the furnace doors—i. e., it lowered the temperature instead of promoting combustion, and (b) it did nothing to overcome the tendency of the sawdust to settle compactly on the grate, which is the principal difficulty encountered in burning sawdust, and which the Gordon Hollow Blast Grate effectually overcomes, as it introduces the blast from below.

Other devices for quickening combustion in sawmill furnaces failed because the "inventors" fell into the error of thinking a "hot blast" beneficial. This is a mistaken supposition. The hotter the air, the more rarified, and the less oxygen it contains. As oxygen is the element that is vital to combustion, it is easy to see why "hot blast" devices failed, or met with but indifferent success.

The Gordon Hollow Blast Grate, mentioned above as the only practical device yet produced for use in sawmills and similar institutions, is manufactured only by the Gordon Hollow Blast Grate Company, Greenville, Michigan. As stated, it has been on the market since 1889, although many minor improvements have been made in it in the years that have elapsed since. Those having difficulty in burning their sawdust, or wishing to increase their power, would do well to write to the makers at the address given.

WESTERN CANADA

Western Offices of The Canada Lumberman,
720-721 Union Bank Building, WINNIPEG, MAN.; 536 Hastings Street, VANCOUVER, B. C.

SOME FEATURES OF LUMBERING IN BRITISH COLUMBIA.

By E. H. NEWTON.

How many of the eastern consumers of the product of our British Columbia mills have any idea of the methods employed by B. C. lumbermen in this the most important of Canadian industries? I opine they are few, and perhaps there are many who have used the little piece of flooring, or the little piece of moulding, or the little piece of whatever it may be; or it may be that their magnificent residence stands in its entirety as a monument to their enterprising B. C. brethren, and yet, I ask, how many of them know, or in fact have even thought of how this beautifully finished product, or this magnificent structure has been made possible to them? They may have seen something of the methods of lumbering in the east, and indeed a trip to a lumber camp in old Ontario or the more eastern provinces is always a pleasant and instructive one, but if you will go with me, kind reader, to the home of those mighty monarchs of this western coast, whose towering tops look far out over the deep blue waters of the great Pacific Ocean, you will be simply spell-bound. For convenience of reaching this spot we will take a trail, or perhaps it may be that we will go in by a sled road (the first part of our trip out from Vancouver being of necessity made by steamboat), which is constructed of skids embedded firmly at a distance of from four to six feet apart with notches cut in them for the runners of the sleds to run in. This road may be used for hauling in the necessary supplies, etc., for the camp.

Arriving at the camp, which is not usually very far from where we left the boat, we get instructions as to which way to go, and pretty soon we come up to a tree and we find two men—one on either side of this tree, standing upon something which appears to have grown out of the sides of the tree perhaps eight or nine feet from the ground for this express purpose. Upon closer examination, but no closer than that with which we have been scrutinized by the fellows occupying those perches, we find that they are contrivances which, though simple in their nature, have been carefully thought out, and seem to exactly fill the requirements. These contrivances are called spring boards, and are held in their position by a simple notch in the side of the tree, and upon these the men stand to notch the front side of the tree which they are going to fell. This notch is usually about a foot deep, but may be more, or less, according to the size of the tree, and this plainly indicates the direction in which the tree is going to fall. Now, these perches are swung back in the other direction by a simple movement of the occupant, and the saw is brought into action on the back side of the tree, but as

this happens to be a large tree they have cut two notches in each side and the spring boards are put in the other notches for the first part of the saw cut, and as the sawing proceeds the board is swung by a slight kick with the heel of the boot. Now the tree is about half cut down and we see them change these spring boards back into the other notches again, and once more perched on top of them they proceed with the cut. They seem to be tugging very hard, and occasionally we see them take up a bottle in which they have some liquid; they do not drink this liquid themselves, however, but pour it on the saw, and by a little inquisitiveness we elucidate the fact that this is coal oil and dogfish oil mixed and that it is used to cut the gum which had run down on the saw and is causing them to exert all this extra effort. Finally the cut is nearly finished and we are watching toward the top of this mighty giant so soon to be laid low; the alarm is now given, but the men tugging at the saw continue at the task. Suddenly a quick convulsive shudder has pervaded every branch of this tree, but still it stands there trembling, and one can almost imagine writhing with the thoughts of having to surrender up its position to its dreaded enemy, but its blood has now long continued to flow, and as a last resource has tried to impede the progress of its fell destroyers by sticking to the saw, but by a free use of oil the saw has been kept going and now we see a quivering which with a mighty crackling sound from the direction of the stump tells us that we have not long to wait. The men stop sawing and look up, then we see them seize the saw and pull it out at the back of the cut, which is now opened sufficiently to make this easy, and having done this they jump to the ground but do not run away to any distance, as they are so well accustomed to the work that they need display no fear. The air is filled with a whistling roar and a thundering sound while reverberations from all directions follow, and for the moment we are not able to see where this towering beauty of a minute or two ago has disappeared to, but presently the dust has cleared away sufficiently to reveal its beauty lying at full length on the ground, conquered for the first time. We walk up to the butt end of it, which has been cut off the stump twelve feet above ground on account of its having no commercial value lower down, or perhaps the stump swells out to such large proportions that it cannot be cut lower; but here we find by taking up the measuring pole which stands there that even at this distance from the ground the tree measures ten feet in diameter. If you should have any inclinations to climb up on top of this mighty monster and there is not a stump or something in close proximity to make the ascent possible, you can readily see that

you might just as well set to work to construct a means.

I well remember a visit which I made, accompanied by an Ontario lumberman, to a camp where a number of these giants had just been felled. He was not like the B. C. lumbermen, he had grown fat in the business in Ontario, and didn't I have fun getting his 240 pounds of avoirdupois up on top of one of these big trees? We got there, but not until I had carried such material as was available and built an improvised ladder up one side of it. But when we reached the top we walked down the tree side by side for a distance of about eighty feet, and could have gone farther but for some undergrowth which had fallen on top of it. But it is you and I, reader, who are there now, and while we stand near one of these mammoth trees we cannot but marvel at the mighty undertakings of man, and as we thus marvel our thoughts go back to the admonition "Go to the ant, thou sluggard; consider her ways, etc.," and we wonder why the ant was held up before man as a criterion, when all at once we are startled by something, and here our wonder increases, for if we are to believe our own eyes, a mammoth tree which had been lying near this one is now moving off bodily. When our mystification has subsided and the fact becomes real that the tree has gone we follow along in its trail, and when a halt is made we investigate the cause of this strange mode of procedure, and we find that down at the other end of the log, which is perhaps 100 or 120 feet in length, a wire cable is hitched on, and we also find that one side of this tree has been peeled and the front end has been "sniped" so that it will not catch on the skids, or on any obstructions which may be along the way. It is very essential that this be nicely done on the under side, else it will catch on the skids on the main road and tear them up, causing great loss. We are now warned to stand back, and before we have receded far this monster again starts off, and when it has passed us we again follow in its trail, and presently it stops again, and here we find from whence this giant of the forest received its inspiration.

We have arrived at the main road, and here stands one of those powerful engines of a special type built expressly for this class of work. This engine does not run on wheels, neither is there any track required for it to run on, but it will go through any ordinary trail where a pair of horses can be comfortably driven, and it furnishes its own power of locomotion. But here we find it hitched to a large stump, and from a drum on the engine a wire cable is run out in any direction from which the log is to be hauled, either by the use of a line horse, or by another cable, but in this instance the line horse is generally used. It is

the duty of this engine to haul the trees out to the main road, which process is called yarding, and this yarding engine may be found any distance from the water within the limit of one mile, and in some instance even farther. Here we find several of these monstrous logs hitched together, one behind the other, and before we have got done wondering what this can mean we see a man hitching a cable on the foremost log, and pretty soon we are again cautioned about standing too close, and the good-natured logger explains the danger in case anything should break, or a hook pull out. Having finished his brief explanation we see him reach up and pull a wire, and believing this to be a signal for something, we repair to a safe distance to watch developments, but when we have moved back a few yards and turn and look round we find that this whole string of logs has started off down this main road. Our curiosity intensifies now, and as soon as the last one has passed us we quickly fall in line and follow up, or at least, try to follow up, but this is a very difficult road to walk on, on account of there being skids of large diameter embedded crosswise about a yard apart, these skids being notched in the middle to a depth of ten inches or a foot. Before we have gone far down this road we find that we have suddenly acquired the habit of sitting down rather too abruptly to be of any benefit to our constitution, and before we have got done wondering why these skids should wear so exceedingly smooth we meet a man with a bucket of grease, and without halting longer than to see him daub one or two skids we are led into the secret of why it had been so easy for us to sit down, and also why those logs had glided off so easily, and having ascertained from him that the logs were stopped just a little way down we hurry on to catch up to them. We do not have long to rest, however, but now that we have become more accustomed to walking on this road we are able to keep in sight for the rest of the trip.

Having reached the water we find here another engine similar to the one which we saw yarding out, but much larger. This one is called a road engine, and is equipped with from one to one and a half miles of cable about $\frac{7}{8}$ inch in diameter, also double this amount of a smaller size used for hauling this heavy one back. This small one runs through a block at the end of the road and is attached to the tow coming in, and thus when one wire comes in the other goes out. When the tow has been landed and it is desired to go back for another the engineer simply releases the drum on which the heavy wire is wound and sets the other one containing the smaller wire in motion, and the man with the unpronounceable name, who accompanies this wire and hooks back, gets a merry ride.

Lumbering on the coast is prosecuted more vigorously in summer than in winter. Indeed, if the operations are far enough back from the coast to run into the snow line they cease entirely on the arrival of snow, and the cause of this is easy to understand when it is known that most of this timber is grown at a great elevation, and could not possibly be controlled

if there was snow, for even in summer sand has to be used on the skids on some of the heavier grades, while in other places it is impossible to handle them on this kind of a road, as the descent is too great, and here a chute is built from the level on which the timber stands to the water, and at the top of this chute the engine is placed and it hauls the tree into the chute and from here it goes down pell mell and plunges into the water two or three thousand feet below. Logging on the coast has not, as yet, been prosecuted far back from the water, and as timber gets scarce, and we are forced farther back, it may not be presuming too much to say that the present method will have become obsolete, for do we not already see in our mind's eye a ray of light reflecting upon something more modern?

We must now leave the affable logger, to whose congeniality much of the pleasure of our trip is due, and now we proceed to the mills where these huge trees are being manufactured into the various sizes and kinds of finished product, from the 48 x 48 if required, and almost any length, to the smallest piece of finish. Here, indeed, is something to be wondered at; the ease with which those big logs are handled in some of our larger mills is marvellous. Whenever a log or a heavy piece cut off one of them, or whether it be heavy or light, whenever it is to be moved or transferred in any direction, it is done, not by the main strength of man, but by his wonderful ingenuity.

The machinery of the coast mills is extra heavy, being of a special design to meet existing demands, and the modern mill, of which we are able to show you several in Vancouver if time only permitted, represents a large amount of money—together with the logging outfit and equipment, a very large sum indeed, which in itself speaks more for the energetic and enterprising British Columbia lumbermen than volumes which might be written.

I am very glad, kind reader, to have had you go with me on this trip. I trust that you have enjoyed it to at least the extent of what it has cost you. When we have rested we may go out again, in this, or some other direction. Our chief aim in life out here is to be of some use to our friends in the east. Intimate your desires; we long to help you.

The Okotoks & High River Lumber Company will have a large cut this season, and will place over 100,000 logs in the boom. The logs are now ready to be rafted down the river to the mill. Mr. J. P. Powell, their manager, is contemplating introducing new machinery and otherwise renovating the mill property the coming summer.

The Western Retail Lumbermen's Association have moved their headquarters into fine commodious apartments on the sixth floor of the McIntyre Block, Winnipeg. They now have splendid quarters in which to receive visiting lumbermen. The insurance scheme promoted by this Association is meeting with great success, and a large number of lumbermen have taken advantage of the low rates offered by the Association. Mr. J. L. Campbell, of Melita, Man., the President of the Association, presided at a meeting of the directors, recently held, at which favorable reports were submitted by Mr. Isaac Cockburn, the Secretary-Treasurer of the Association. Mr. Cockburn proves to be wide awake and indefatigable in his efforts to promote the interests of the retail lumbermen.

MR. ARCHIBALD LEITCH.

Mr. Archibald Leitch, president of the East Kootenay Lumber Company, Cranbrook, B.C., is a gentleman of sterling qualities, well and favorably known throughout British Columbia and the Northwest. He is a pioneer lumberman and reports trade as having picked up wonderfully this season.

The East Kootenay Lumber Company operate three mills, located at Ryan, Cranbrook and



MR. ARCHIBALD LEITCH,
President East Kootenay Lumber Company.

Jaffray, the head office of the company being at Cranbrook. These mills are now running steadily and will make a total cut this season of over 18,000,000 feet.

The Hazelmere Lumber Company, Hazelmere, B.C., have made extensive improvements to their mill having installed a thirty-six three-saw edger and new boiler and engine. The manager, George M. Thrift is looking forward to a successful year.

David Brown, an employee of the Big Bend Lumber Company, Arrowhead, B.C., was caught between the trailer of the log carriage and the buffer in the mill and so seriously injured that he died from the shock. William Childs, edgerman for the Kamloops Lumber Company, Kamloops, B.C., was hit on the head by a flying board from the edger and killed almost instantly.

The Schaake Machine Works, of New Westminster, are building a saw mill for Harry Freeman, of Aldergroove, B.C., in addition to his shingle mill. The capacity of the new saw mill will be 10,000 feet per day. The same company have just undertaken the rebuilding and improving of a logging locomotive for A. Haslam, of Nanaimo, B.C., who has his mill operating to its full capacity.

The saw-mill of the Royal City Planing Mills Co. at New Westminster has been considerably improved. The mill itself has been thoroughly overhauled and put in better shape to meet the increasing business of the firm. The boiler room, which was formerly under the mill, is now contained in a new brick building. Eight boilers are in use, three new ones manufactured by the Wm. Hamilton Company of Peterboro having been put in. In connection with the change of boiler rooms a special draft system has been installed for the purpose of doing away with the cinders, sparks and smoke. This system includes the use of a 100 inch fan with special engine to drive it. It was purchased from the Buffalo Forge Company, of Buffalo. In addition to these improvements the company has also put in two new cyclones, for the purpose of removing shavings and cuttings, one for the factory and the other for the mill. Pipe connections are made to all the machines.

THE Wood-Worker and Retailer

TEMPERING PLANING KNIVES AND MOULDING CUTTERS.

In forging or hardening moulding irons it is important that they should be heated as evenly as possible, for if one part of the cutter is thinner than the other, care must be taken that the thin part does not heat more rapidly than the rest, or it may be burnt and break off at the cutting edge while at work. In heating cutters for tempering they should be repeatedly turned over in the fire and withdrawn from it occasionally. In the case of moulding cutters, if the cutting edge is heating too rapidly, it should be pushed through the fire into cooler coals. If there are a number of cutters, great care should be taken to temper them as nearly alike as possible, or they will vary in wear and the outline of the work will vary accordingly.

It is important in tempering any kind of tools that there shall be a gradual shading of color. If there is a distinct line between the colors toward the edge of the cutter, it will probably chip at this line. The point to aim at is to have the edge of the cutter fairly hard, and this hardness to be reduced as you go farther from the cutting edge, and the softer metal at the back will be found to strengthen and support it.

Great skill is requisite in tempering, owing to the varying amount of carbon contained in different steels, to suit which the amount of temper must vary accordingly, and the proper temper can only be ascertained after one or more trials. As a rule, different brands of steel cannot be treated alike, and this very fact explains why one smith will prefer one manufacture of steel, because of his familiarity and success in working it, while another may think ill of it.

It may be taken as a rule that if it is necessary to heat the steel so hot that when it is annealed it appears closer in the grain than the place from which it was cut, it is of too low a temper for the required work, and a steel of higher temper should be selected. A steel cutter, when properly tempered and suited to

the work in hand, should always be of a finer grain than the piece from which it was cut. The process of tempering should be gradual, as the steel becomes toughened, and less liable to fracture by slow heating and gradual softening than if the process be performed abruptly. When the proper heat is reached, the tool should be removed from the fire.

In forging, welding or tempering steel tools, any excess of heat over what is necessary is

the frames and mandrels are coupled in the centre.

By means of the variable friction feed, their machines are easily adapted to the power, character of the work and condition of the saws. The worm gear is employed in connection with the friction feed to convert the high speed into power with less machinery, while it makes a more durable rig than would be possible with ordinary gears.

The feed and the attachment for operating the head blocks, the latter reversible, are controlled from the front end of the machine. This is a very important feature and entirely new in this class of machines.

The design of the head blocks is also claimed to be superior. They are extra heavy and made in one solid

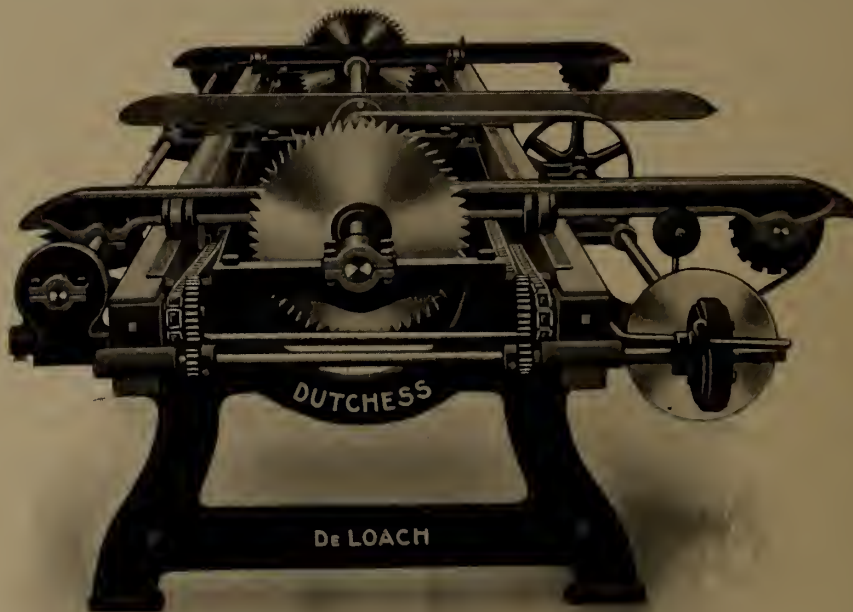

DELOACH "DUTCHESS" TRIMMER.

detrimental, as it opens and makes the grain of the steel coarser. If a tough temper is required, the cooling should be as slow as possible. The right color in tempering will vary with the steel and the hardness required. —Packages.

DELOACH LUMBER TRIMMERS.

The DeLoach Mill Manufacturing Company of Atlanta, Georgia, desire to call the attention of lumber manufacturers to the superior design of their trimmers, and particularly to the fact that the frames are made narrow and more shapely than is usual and also that

casting, each being mounted on four 4 inch rollers, which operate on heavy wrought iron tracks and are controlled by sprocket chain, which is positive and reliable.

The mandrel has four permanent and two movable bearings, the latter forming part of the head blocks and guides for the saws, and they, as well as the fixed bearings, are fitted with chain oiling boxes.

The driving pulley is placed on the end of the machine as shown, except when specially ordered in the centre or on the opposite end. With only the iron feet resting on the floor, the machine sets firmer and is more convenient for cleaning underneath, making the outlines more shapely and dispensing with the severely clumsy appearance usual in trimmers.

Views of the DeLoach "Dutchess" trimmer are shown herewith.



DELOACH "DUTCHESS" TRIMMER.

FOR THE CAMP

We have a very suitable lot of goods for camp supplies. We make this kind of trade a specialty. You who are not getting suited just as well as you would like, try us for your next order, and give us a chance to demonstrate our ability to give you satisfaction in this very important department of your business.

H. P. ECKARDT & CO.

Wholesale Grocers

TORONTO

THE SURVEYOR GENERAL OF NEW BRUNSWICK.

Hon. Francis J. Sweeney, who has recently been appointed Surveyor-General of New Brunswick, and will therefore have charge of the timber lands of the province, was born of Irish Catholic parents at Melrose, Westmoreland County, N.B., on April 21, 1862. He was educated in common schools, at Shediac Grammar school, and at St. Joseph's college, Memramcook. For a time he attended the Normal School and taught some years in St. Malachi's hall, St John, with much success. He studied law in St. John, and after graduat-



HON. F. J. SWEENEY,
Surveyor General of New Brunswick.

ing practised at Moncton. Hon. Mr. Sweeney entered public life in February, 1903, being elected to the Legislature as the representative of Westmoreland County, entering the Tweedie Government without portfolio a few weeks later at the opening of the Legislative session of that year. In December, 1904, he was appointed Solicitor General, and after holding the position for two months was promoted to Surveyor General, an office of greater importance.

Mr. Sweeney is a splendid public speaker, a gentleman of broad views and personally enjoys a large measure of popularity. His administration of the Crown lands will, we feel sure, give general satisfaction.

R. Tait, of Orillia, is said to be considering the erection of a saw mill near New Westminster, B. C.

PUBLICATIONS.

The Thompson Manufacturing Company, Grand Bay, N.B., call attention in recent circulars to their horse shoer's vise, a useful tool for the horse shoer at small expense.

A supplementary catalogue has just been issued by the Marine Iron Works, Station A, Chicago, that will be sent free on request. It contains illustrated descriptive matter pertaining to some of their latest steam-boat work.

Two catalogues have come to hand during the past month from Sheldon & Sheldon, Galt, Ont., No. 19 being devoted to steel plate planing mill exhausters, shaving separators and blast grates, and No. 20 to medium blowers and exhausters.

Millmen will appreciate the catalogue entitled "Setting Machines for Saw Mills", issued by the William Hamilton Manufacturing Company, Peterboro, Ont. It contains a complete list of hand, steam and power set works suitable for any saw mill, with illustrations.

P. Payette & Company, of Penetanguishene, Ont., are preparing a booklet for distribution referring to their latest patent mill dogs and lath mill machinery. This firm have recently built a new compound condensing engine for the private yacht of Chew & Sons, of Midland.

The catalogue issued by Samuel J. Shimer & Sons, of Milton, Pa., illustrates and describes the Shimer cutter heads and shows some new tools which have not heretofore been offered to the trade. It contains net selling prices and numerous illustrations and patterns of use to general woodworkers.

Persons in the market for pumps, steam boilers, condensers, pulleys, etc., will no doubt find something of interest in the numerous catalogues to be had from the John McDougall Caledonian Iron Works Company, of Montreal. They are Canadian agents for Wickes Bros., manufacturers of steam boilers, feed water heaters, etc., Saginaw, Mich.

Catalogue No. 10, issued by the McEachren Heating & Ventilating Company, Galt, Ont., although small in size, contains a vast amount of information concerning McEachren heating, ventilating and drying appliances, planing mill exhausters, blowers, fans, exhaust heads, etc. The illustrations are clear and readily understood by practical men.

One of the most extensive and complete catalogues which has yet reached our desk is that issued by the Defiance Machine Works, inventors and builders of patent woodworking machinery, Defiance, Ohio. Following some excellent views of the company's works are to be found illustrations and descriptions in detail of the large range of machines and tools which they manufacture, which include many special machines which can be used to advantage in saw mills and woodworking factories.

We doubt if a more complete catalogue of saw mill machinery has ever been issued than that bearing the name of the DeLoach Mill Manufacturing Company, of Atlanta, Georgia. Besides giving particulars and illustrations of the numerous machines which they manufacture, it contains much information of value to mill men. The DeLoach Mill Manufacturing Company

claim to have the largest saw mill manufacturing plant in the world, which is equipped with new and modern tools electrically driven. Their line includes almost everything required for a saw mill, as well as turbine water wheels, which they make in two styles.

THE CANADIAN CASUALTY AND BOILER INSURANCE COMPANY.

In the two years since this Company was organized, it has made rapid strides, the result of activity on the part of the management combined with an extensive organization. The financial report of the Company before us indicates that a good deal of energetic work has been done, as over \$5,000,000 of insurance is in force on the Company's books at the close of its financial year, earning an annual income to the Company of some \$50,000.

The Canadian Casualty and Boiler Insurance Company enjoys the distinction of being regarded as one of the best consulting engineering and boiler inspection and insurance companies in Canada. A competent staff of inspectors is employed by this Company, whose reputation for skilled engineering work and experience extends over a period of many years.

The Company has offices in all the principal cities of Canada, and the greatest care is exercised in making inspections—in fact a very high standard is set in this regard.

We are pleased to see this Company of such practical assistance to steam users generally in the advice sent out from time to time by their advisory department.

We have before us two bulletins, No. 1 treating of Boiler Scale, No. 2 treating of the Effect of Oil in Boilers. These bulletins are sent out to not only their policyholders but to every steam user who may desire to receive them, for the asking.

Although a young Company, it has already taken front rank and proven its responsibility, its work being appreciated by the steam users of Canada. We can ourselves speak of the engineering staff as comprising practical engineers of repute known all over Canada. The head offices of the Company are at 22 and 24 Adelaide Street East, Toronto.

IMPROVEMENT ON SAWS.

A United States patent has been issued to W. J. Cummings and S. Abernethy, of Port Moody, B. C., on an improvement in inserted teeth for saws. This invention is applicable to inserted teeth of the kind exemplified by the Howe, Simonds and Disston, and is directed to prevent the tendency to lateral displacement of the cutting edge of the bit, which is a common fault in saw teeth of this class, and which not only is productive of rough work, but by permitting sawdust to escape from the gullet past the swage of the lock portion, causes heating of the blade of the saw with its attendant injurious effects. In the invention a V-shaped projection is provided extending as a chord across the seat of the bit on which the heel of the lock portion bears, which projection fits into and laterally engages a similarly shaped groove in the heel of the bit, and any tendency to lateral displacement is thus prevented.

W. W. Janney has registered the Montreal business of the R. H. Smith Company, Limited, saw manufacturers,

THE NEWS

ONTARIO.

—A. H. Rozel has sold his planing mill at Tilbury, Ont., to H. Sloan.

—Thomas Ker, of Walkerton, Ont., has purchased a saw mill at Broadbent.

—A new planing mill is being built at Lyndhurst, Ont., by Roddick & Son.

—The Chatham Bent Goods Company purpose building a woodworking factory at Chatham, Ont.

—Trussler Bros., Limited, Trout Creek, Ont., are advertising their general store and lumber business for sale.

—According to the official declaration, the estate of the late Claude McLachlan, of Arnprior, Ont., is valued at \$757,389.

—The stables of the Pigeon River Lumber Company at Port Arthur, Ont., were destroyed by fire last month, entailing a loss of about \$5,000.

—The Rainy River Lumber Company, Rainy River, Ont., are this spring building a number of houses for their employees.

—Seamen-Kent & Company, of Meaford, Ont., are supplying a large quantity of hardwood flooring for the new Eaton building in Winnipeg.

—The saw mill business of James Lunny & Company at Hintonburg, Ont., will be conducted after July 1st next under the name of J. Gordon MacLaren.

—Knight Bros., of Burk's Falls, Ont., have converted their business into a joint stock company, to be known as the Knight Bros. Company, Limited, and to have a capital of \$150,000.

—P. W. Gardiner & Sons are building a new planing mill at Galt, Ont. It will be a two-storey stone structure, 92 x 80 feet. The power plant will be supplied by the Goldie & McCulloch Company.

—W. D. Davidson, of Rawdon, Quebec, is endeavoring to secure capital for the establishing of a woodenware factory at Haileybury, New Ontario. He proposes to manufacture axe handles and similar goods.

—Wilson Bros., of Collingwood, Ont., have formed a joint stock company, under the name of Wilson Bros., Limited, with a capital of \$75,000. Daniel Wilson, Abraham Matts and Hugh A. Currie are the provisional directors.

—J. S. Find'ay, Owen Sound, Ont., is installing an automatic band rip saw manufactured by the J. A. Fay & Egan Company, of Cincinnati, also a few other special machines for the manufacture of bed spring frames.

—The Thornbury Planing Mill Company, Limited, Thornbury, Ont., has been incorporated, with a capital of \$20,000. The provisional directors are Henry Pedwell, J. H. McLean, A. Macdonald and A. C. Beatie, of

Thornbury, and T. B. White, cooperage manufacturer, of Township of Collingwood.

—F. McGibbon & Sons, of Penetanguishene, Ont., have installed in their mill the following new machinery, all of which was supplied by P. Payette & Company, Penetanguishene: Steam nigger, kicker, loader, edger, steam feed, carriage and mill dogs.

—A boiler in the mill of the Neibergall Stave & Lumber Company at Staples, Ont., exploded on May 22nd, killing Ralph Welsh and injuring eight persons. The accident is believed to have been due to too much cold water being injected into the boilers.

—The Windsor Lumber Company, Limited, capital \$100,000 and head office at Windsor, Ont., has been incorporated, the provisional directors being James Grafton, of Dermot, Arkansas, and Thomas Watson, J. A. Straith, C. E. Fleming and J. H. Carson, of Windsor.

—The Sarjeant Company, Limited, Barrie, Ont., has been incorporated by the Ontario Government, with a capital stock of \$50,000, to manufacture lumber, etc. The provisional directors are Walter Sarjeant and Samuel Sarjeant, of Barrie, and William Sarjeant, of Orillia.

—The Rat Portage Lumber Company have added to their plant at Vancouver by the installation of two more planers, a small 4-inch band saw, a self-feed rip saw, a new lathe for the small work and a new lath mill. They have also completed a lumber sorter which adds very materially to the speed and convenience of sorting lumber. A number of other smaller improvements and repairs have also been completed.

—The Bryan Manufacturing Company, of Collingwood, Ont., find it necessary to increase their plant and have placed a contract with the Collingwood Shipbuilding Company for a steel boiler of 100 horse power, together with furnace and stack. The latter will be of steel 4 feet in diameter and 100 feet in height. They also propose to erect a large brick warehouse and make improvements in their planing mill.

—The Colonial Lumber Company, Limited, has been formed with a capital of \$100,000, to operate the lumber property in the Ottawa Valley recently purchased from A. & P. White, of Pembroke. The directors of the company are J. W. Smith, E. J. Chamberlin, C. J. H. Bethune, and M. G. Larmouth, of Ottawa, and R. V. Gordon, of Pembroke. Ottawa is stated to be the chief place of business.

THE EASTERN PROVINCES.

—The Albion Lumber Company, of Moser River, N. S., are not operating their mill this season.

—James Murchie & Sons, who operate in New Brunswick and Maine, have recently built a large saw mill at Calais, Maine.

—The Davison Lumber Company are making Springfield, N.S., a very important industrial centre by their extensive lumbering operations. Besides building a logging railroad, they have recently completed a new

saw mill 200x65 feet and three stories high. They propose to install a plant for the manufacture of wood charcoal and wood alcohol.

—The Bay Shore Lumber Company will probably increase the manufacturing capacity of their mills at Salmon River, N. B.

—White & Fownes & White's mill is operating this summer at Handford Brook, N.B., for the Hammond River Lumber Company.

—W. B. Stillwell, a millwright in Sayre & Holly's mill at Chipman, N. B., was killed last month by being caught in the machinery.

—Mrs. P. Larose has registered as proprietress of the business of Larose & Larose, sash and door manufacturers, Montreal.

—Burgess & Sons have installed a new gang of 36 saws in their mill at Grand Falls, N. B. It was supplied by Alex. Dunbar & Sons, of Woodstock.

—The A. L. Slipp Lumber Company, Limited, Salisbury, N. B., has been incorporated by L. A. Wright, of Salisbury, J. E. Slipp, G. N. Pearson, and S. A. McLeod, of Snssex, and James E. Price, of Norton. Capital, \$70,000.

—The A. L. Wright Lumber Company, Limited, has recently been incorporated by the Brunswick Government, to acquire the lumber business and property of Alexander Wright & Company at Cloverdale, N. B. The capital stock is placed at \$75,000.

—Senator Edwards and J. R. Booth, of Ottawa, and W. Price, of Quebec, representing the Quebec Timber Limit Owners' Association, recently had an interview with the Minister of Lands and Mines relative to the re-organization of the forest fire protection system of the province and the woods and forests branch.

—The following lumber surveyors have been appointed at St. John, N. B.: Samuel K. Wilson, Otto Renneke, Comly Robertson, Jordan K. Jones, Herbert J. McLoon, Elias H. Robinson, George Y. F. Wilson, John Sullivan, Henry Gaskin, J. Henry Durick, Frank A. Courtney, Herbert E. Price and Ernest E. Staples.

—A New Brunswick charter has been granted to the O. F. Stacy Company, Limited, of Bathurst, N. B. The capital stock is \$50,000 and it is proposed to acquire the saw mills, timber limits, and other property of O. F. Stacy & Company in the parishes of Bathurst and Beresford, N. B. The directors of the company include O. F. Stacy, George Gilbert, and W. T. White, of Bathurst, and John R. Carter, of Woburn, Mass.

—The Restigouche Wood-Working Company, Limited, held their first regular meeting at Dalhousie, N. B., on May 15th, when the following officers were elected: President and manager, W. S. Montgomery; vice-president, George E. Mercier; secretary-treasurer, R. Y. Blackall; superintendent of works, Gilbert Leveillee. The company are now ready to manufacture doors, sashes and other building materials. The main factory is 150 x 54 feet, dry house 130 x 36 feet, warehouse and office 130 x 30 feet, and boiler and engine house 30 x 40 feet.

CRAIG MINE CRYSTAL CORUNDUM WHEELS

Our Pure Crystal Corundum Saw Gummars have no equal for their Rapid, Cool, Cutting Properties.

Read the following from Bulletin 180 of the United States Geological Survey, which says:

"Often a distinction is made between emery and corundum, many persons not recognizing emery as a variety of corundum.

Emery is a mechanical admixture of corundum and magnetite or hematite. It is, of course, the presence of corundum in the emery that gives to it its abrasive qualities and makes it of commercial value, and the abrasive efficiency of emeries varies according to the percentage of corundum they contain."

Emery is imported, mined by Greeks and Turks and contains only about 25% corundum. Our Crystal Corundum is guaranteed to be 98% pure alumina, a Canadian product, mined and manufactured by Canadians for Canadians.

HART CORUNDUM WHEEL COMPANY, Limited, Hamilton, Ont, Can.



MANITOBA AND THE TERRITORIES.

—A. B. McLelland has opened a lumber yard in Winnipeg, Man.
 —Robert Murray, lumber dealer, Lyleton, N. W. T., has been succeeded by Murray & Lyle.
 —The dissolution is announced of Campbell & McGregor, lumber dealers, Manitou, Man.
 —Boez & Joyce, lumber dealers, Regina, N. W. T., have dissolved partnership, Mr. Joyce continuing the business.
 —The Cushing Bros. Company, Limited, of Calgary, N. W. T., have remodelled their Regina plant and installed new woodworking machinery.
 —The Melita Lumber & Manufacturing Company, of Melita, Man., has been incorporated by A. M. Campbell, James Duncan, A. E. Ward, and others. The capital stock is \$50,000 and it is proposed to acquire the sash, door and pump factory owned by Moorby, Badgley & Ward.

BRITISH COLUMBIA.

—The Kawatsie Lumber Manufacturing Company, Kawatsie, B. C., have commenced business.
 —A. Haslam, of Nainamo, B. C., has completed a logging railway at Jervis Inlet, two and a half miles in length.
 —The Bowman Lumber Company, of Revelstoke, B.C., are increasing the steam power of their mill at Comaplix.
 —The Taylor-Pattison Mill Company, Limited, has recently been incorporated by the British Columbia Government, with a capital of \$50,000.
 —The British Columbia Tie and Lumber Company, Limited, has secured a provincial charter, with a capital of \$250,000, to acquire timber limits and conduct a general lumbering business.
 —The Crow's Nest Pass Coal Company's mill at Carbon Creek, 3 miles east of Mitchell, B.C., is cutting about twenty-five thousand feet per diem, principally fir and tamarac.
 —The Fernie Manufacturing Company's plant at Fernie, B.C., has been idle for over a year, being in the hands of the Union Bank as liquidators. They manufactured sash and doors, etc.
 —Mr. John A. McLean, of Fernie, B.C., says prices for B.C. lumber will be fairly good this year, the outlook being particularly bright and stock moving out well. He has some timber land for sale.
 —Mr. Kinman, formerly of the Trout Lake Lumber Company, Trout Lake, B. C., is engaged on a large logging contract for W. Munday, who has acquired timber limits and is building a mill near Revelstoke.
 —The Kamloops Lumber Company have completed their new saw mill at Kamloops, B. C. The equipment is very complete and includes an Allis double-cutting band mill, supplied by the Waterous Company. Most of the planing mill machinery was supplied by MacGregor, Gourlay & Company, of Galt, Ont.
 —The saw mill business at Wardrop, B. C., will here-

after be conducted by the Sparwood Lumber Company, Limited, W. J. McKinley and E. K. J. Foster having acquired an interest in the business. A new planer and additional power plant have been installed.

—The electric lighting plant which has been installed by the Hinton Electric Company in the mill of the Columbia River Lumber Company at Golden, B. C., consists of a 12 h. p. Bullock dynamo belted to a 7x8 Champion engine, together with a slate switchboard.

—The Morrissey Lumber Company's mill at Morrissey, B.C., has been shut down since last year. The McRae Company's mill, which was sold to the Alex. Black Lumber Company of Winnipeg, is situated at Hosmer, B.C. It has also been closed since last fall.

—A Boston syndicate is said to have had plans prepared for a large saw mill to be built on Quatsino Sound, Vancouver Island, B.C., and to have a capacity of 200,000 feet per day. It is proposed to manufacture cedar almost exclusively and to ship shingles very largely to the Eastern States.

—The plant of the Vancouver Lumber Company, Vancouver, has been greatly increased, a new planing mill, dry kiln, and dressed lumber shed having been erected; also a new office building which is probably the handsomest lumber office in the province. The Company intend manufacturing lumber exclusively.

—R. McMurdo and J. W. Thickens, of Appleton, Wis., spent several weeks last summer in British Columbia and purchased some timber limits in the vicinity of Golden. A company of Wisconsin capitalists is being incorporated for the purpose of working the limits. A saw mill will be erected on the Blaeberry river during the coming summer.

—The shingle manufacturing concern known as the Hunting-Lea Lumber Company, of Vancouver, B.C., will henceforth be known as the W. F. Hunting Lumber Company. The company contemplate building another mill twice the size of the present one. The total capacity, it is estimated, will then be 500,000 feet per day. It is the intention to put in the upright style of shingle mill.

—At Elkworth, B.C., near Krag Station, is situated the new mill belonging to the Sussex Lumber Company, of which Malcolm McInnes is manager and J. A. McArthur, of Sussex, N.B., one of the leading stockholders. They will have four or five years cut at that point. The mill is situated on the mountain side, overlooking the Kootenay Valley. The Great Northern Railway runs past the place. The timber is got from the surrounding neighborhood and hauled to the mill, where it is "dry cut", then run down to piling grounds on the lower level by means of skids and rollers, ready to be shipped.

—Messrs. Letson & Burpee, of Vancouver, manufacturers of mill machinery, etc., have recently enlarged their premises to almost double the former size. To the machine shop has been built an addition some 50x50 feet square, and a new foundry and large pattern loft have been erected. New and modern machinery has been installed, including an enormous lathe with a 72" swing, taking 23 feet between centres.

—A new town on the main line of the Canadian Pacific Railway, 14 miles west of Revelstoke, B. C., has been named Munday, in view of the fact that W. Munday, of Philadelphia, is building a large saw mill there. The plant, which is nearing completion, will have a capacity of 75,000 feet per day. The engine which will operate the mill is one which was awarded first prize at the St. Louis World's Fair. A system of waterworks for the village has been arranged for and electric light is to be provided.

—The A. J. Burton Saw Company, of Vancouver, have engaged Ferris Baughman to take charge of the mechanical end of their plant. Mr. Baughman has had a wide experience in this work, having been formerly in the employ of the Simonds Mfg. Company, of Pittsburg, Pa., and latter in charge of the Seattle branch of E. C. Atkins & Company. They have also secured the services of Julius Ingman, of Portland, Ore., as head of their grinding department. Messrs. Burton feel highly pleased at their good fortune in securing two such highly qualified men, and anticipate splendid things for the future.

—Ross Bros. & Company, successors to the Elkmouth Lumber Company, Krag, B.C., will cut over three million feet this year—principally fir, white pine and tamarac. The Ross Company are a young and hustling combination, who are building up a fine business by simply attending to the business themselves and not delegating it entirely to others. Mr. Ross very aptly says:—"The way to success in lumbering is not gained by having a top-heavy clerical staff with no practical men to look after outside work." The man in the office can't stop the leaks, and that is what counts towards prosperity.

—The Cascade Mills, Limited, of Vancouver, which has been organized to take over the plant and property of the old Cascade Lumber Company, have installed new and additional machinery and the plant is now running in full swing. The additions and improvements consist of another shingle mill, manufactured by Letson & Burpee, of Vancouver, a new drag saw and the old engine replaced by one of 125 h.p. of the Armington & Sim's make. The whole interior of the plant has been remodelled and the daily capacity increased about 25 per cent. A new boarding house for the employees has been built on the mill property, where about 40 men can be accommodated. Besides manufacturing and selling shingles, the Cascade people are now dealing in all lines of Pacific Coast timber products. Their facilities for prompt shipments are unexcelled.

RAILS and TRACK SUPPLIES

NEW and Re-laying from 12 to 60 lbs. per yard with fastenings; for Lumbering, Mining and Contracting Work. Immediate shipment from Stock. Get our prices before purchasing.

SESSENWEIN BROS.,

101 Shannon Street, Montreal.

The Man Who Knows He Has a Good Thing



Hanchett Circular Saw Shaper

is always glad to send it out on trial, for he knows that is the best way meritorious goods can get an even show with weaker imitations.

We are always glad to send the Hanchett Saw Swages and Pressure Side Shapers out on approval. Will save your saws and make them need less care when fitted with these tools.

Let us send them to you for 30 days use. Our Circular "F" tells all about them. Write us.

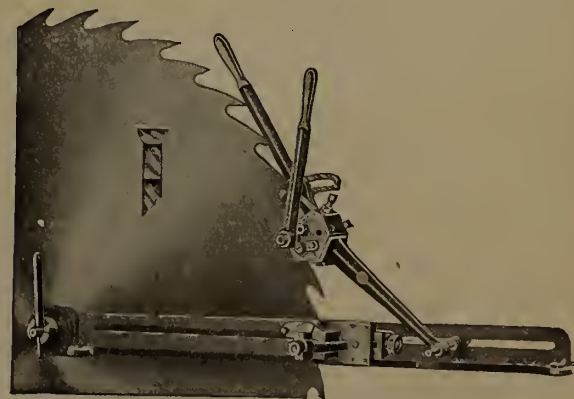

Hanchett Circular Saw Swage

HANCHETT SWAGE WORKS, BIG RAPIDS, MICH., U.S.A.
 Hanchett Swages Do Good Work

FORESTRY DEPARTMENT

PROPOSED FOREST RESERVE IN GASPE.

Mr. W. C. J. Hall, in a letter in the Quebec Chronicle, points out that in the Gaspé peninsula there exists an excellent opportunity of creating a valuable forest reserve. He describes the territory suitable for such a reserve as follows:

"Commencing at the intersection of the 67th meridian, thence along the rear line of Bonaventure County; thence on the same bearing to the 65th meridian at Lac Edouard; thence north along the 65th meridian to the 49th parallel; thence east along the 49th parallel to the intersection with rear line of Township Cap Chat, thence following rear line of Township Romieu and Dalibaire and Cherbouurg to the 67th meridian; thence south along the 67th meridian to the place of beginning, comprising an area of about 2,500 square miles, or say 1,500,000 acres, more or less.

"Quite a large percentage of this territory is under license to lumbermen, and if created a

reserve these limits would immediately be enhanced in value and better bids would be obtainable for the lands not already licensed when put up for sale. The name suggested for the reserve is the "Gaspean Forest Reserve."

A PRIMER OF FORESTRY.

As a source of positive information about what forestry really is, and to spread a knowledge of its methods, a book has been prepared by Mr. Gifford Pinchot, Forester of the United States Department of Agriculture and Chief of the Bureau of Forestry, entitled "A Primer of Forestry," which is published in two parts. Part 1 was issued in 1899, and has passed through several editions, reaching a circulation of about 225,000 copies. It deals with the life of a single tree, with trees as they exist in a forest, with the life of a forest, and with the enemies of the forest. Part 2 of the Primer has just been published. It deals with "Practical Forestry," the purpose of which is defined as "to make the forest render its best service to man in such a way as to increase rather than to diminish its usefulness in the future." In

other words, it means both the use and the preservation of the forest."

THE CANADA LUMBERMAN A GOOD SALESMAN.

The Rodgers Iron Manufacturing Company, manufacturers of saw mill machinery, Muskegon, Mich., write THE CANADA LUMBERMAN under date of May 10, 1905, as follows: "We recently received an order for some of our saw mill machinery, including large combination gang edger and tie machine, from Auckland, New Zealand. The parties were kind enough to mention the fact that they had seen mention of this machinery in the CANADA LUMBERMAN. We expect to make shipment within the next thirty days."

The Remington-Martin Company, of Norfolk, are to plant over 30,000 spruce trees imported from Germany on their holdings in the Adirondacks. This is the first time that a pulp company has attempted such a step, and it is understood that they expect to be able to log the tract in about twenty years.

C. H. VOGEL

A. M. Can. Soc. C.E.
OTTAWA, CAN. ENGINEER
Surveys, Plans, Specifications and Supervision
WATER POWER
Paper, Pulp and Sulphite Fibre Mills

The "Challenge" Pulp Wood Barker

WITH AUTOMATIC WOOD TURNING ATTACHMENT

Correct in design; substantial in construction. Extra long ring-oiling bearings ensure easy running. Capacity a cord an hour. Two sizes 52" and 60". Several of the latter size in stock. Furnished with automatic attachment as shown or without if desired.

Write for Bulletin 500

THE JENCKES MACHINE CO., LIMITED

WORKS AND HEAD OFFICE 48 Lansdowne St. Sherbrooke, Que.

Cables: CHALLENGE

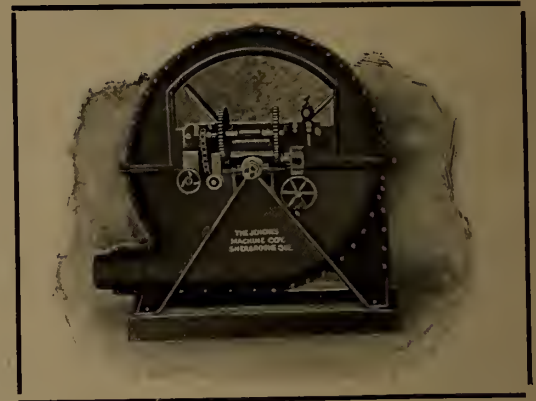

LIEBERS
CODES: ABC 4th Ed.
PRIVATE

BOILERS FOR ALL SERVICES

Return Tubular, Water Tube, Marine, Lancashire, Etc.

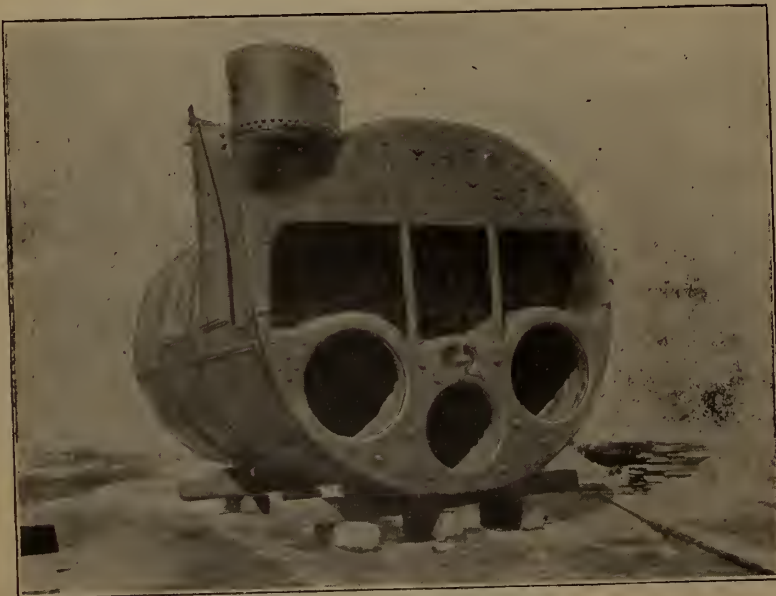

One of two Marine Boilers built in our shops for the Richelieu & Ontario Navigation Co's Steamer "Carolina." Length 21', diameter 13' 4", height 11' 10", weight 37½ tons.

*Engines, "Worthington"
Pumps, Forgings and
Castings of every description*

THE JOHN McDOUGALL
CALEDONIAN IRON WORKS CO., LIMITED,
MONTREAL

There are special inducements in the way of low insurance rates for Canadian lumber risks.

We are fully familiar with the prevailing rates, under varying conditions. If you will write us, briefly describing your situation, we will know, and advise you immediately, whether or not we can save you money.

Many prominent Canadian lumbermen are availing themselves of our low rate indemnity. The opportunity is open to you.

Write us.

Lumber Insurance Company of New York

66 Broadway, NEW YORK

PERSONAL.

The LUMBERMAN received a pleasant call recently from Mr. Walter J. Raynham, secretary of the firm of Walcot, Limited, 17 Gracechurch street, London, England. Mr. Raynham is making a trip to the Southern States with a view of obtaining certain kinds of timber, principally oak suitable for railway car construction meet the requirements of clients.

Mes W. C. West, of the Sutherland-Innes Company Chatham; A. A. Scott, of McGregor, and Neil Watson, of Mull, Ont., were delegates to the seventh annual convention of the National Slack Cooperage

Stock Manufacturers' Association held at Louisville, Kentucky, last month.

Mr. E. Stewart, Superintendent of Forestry for the Dominion Government, is now making a tour of inspection of the forests of France and Germany. He has been granted full official opportunities of studying methods which might be adopted for the improvement of the Canadian forestry system.

Hon. Arthur Hill, president of the St. Anthony Lumber Company, Whitney, Ont., returned early in May from Egypt, where he spent the winter with his family.

Mr. R. B. Fisher, manager of the Drake Lumber Company, Selkirk, Man., died last month from pneumonia.

Mr. M. M. Manville, for many years a pilot and steamboat captain on Lake Champlain, but lately engaged in the lumber trade in Canada, died recently at his home in Whitehall, N. Y.

PAT. OSCILLATING BOB SLED KNEE

Hauls 25 per cent. easier, and wears longer, and is lighter than all others.

THOMPSON MFG. CO., Ltd.,
Grand Bay, N. B.

PAROID ROOFING

"IT LASTS"

We are now ready to do business in Canada and want Lumberman dealers in every section. Our proposition will surely interest you and you can add considerable to your profits by handling Paroid as a side line. It does not conflict with your other business but rather helps it.

Paroid for many years has been the standard of quality in the States and Canada. It is adapted to all kinds of buildings in every climate. Send to-day for samples and our special dealer's proposition.

F. W. BIRD & SON, MAKERS, Hamilton, Ont.

Established in East Walpole, Mass., U. S. A. in 1817.

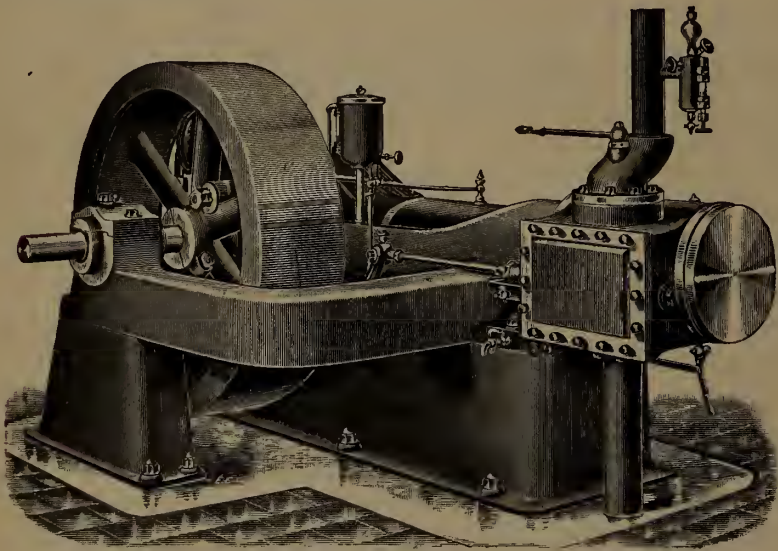

Our Engines are fitted with Automatic Governors and run at Regular Speed, whether Loaded or Light.

They use about 25 Per Cent Less Steam than the best engines with a throttling governor.

They are built on the Interchangeable System so that duplicate parts exact in fit can be supplied at any time.

In Sizes up to 125 Horse Power the outboard bearing is attached to the frame, as shown in the cut, keeping it perfectly in line.

ROBB ENGINEERING CO., LIMITED

Amherst, N.S.

Gonnell & Dengler Machine Co.

ROCHESTER, N. Y.

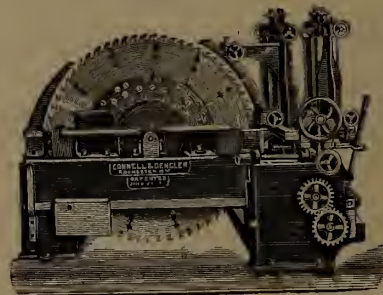

44 inch Circular Re-Saw.



60 inch Band Re-Saw

Manufacturers
of . . .

Box Makers' and Planing Mill Machinery



Heavy 26 inch Divided Roll Planer and Matcher with 8 Feed Roll

THE DOBLE WATER WHEEL.

The Abner Doble Company, of San Francisco, announce that arrangements have been made with the John McDougall Caledonian Iron Works Company, Limited, of Montreal, Canada, whereby the latter become sole licensees for the manufacture of the Doble system of water wheels in the Dominion of Canada. Tangential water wheels and needle regulating nozzles manufactured by the Abner Doble Company are well known for their excellence of design and workmanship, and considerable engineering interest has recently been shown in relation to the four 8,000 horse power wheels which that company has built for operation in California power plants. The McDougall Company have one of the most extensive machine works in

Canada, their plant including machine shops, pattern shops, foundry, forging works and structural material shop. Their plant is therefore well equipped for the manufacture of water wheels and other hydraulic machinery. They already have in hand the building of a 100 horse power wheel to operate under 170 ft. head, taking water through a 3½ in. jet, and having a speed of 130 revolutions per minute. The Canadian licensees are prepared to furnish the steel pipe, structural work and all machinery necessary for complete power plants, and the Doble Company requests that all engineers or parties interested in water power developments in Canada, address the McDougall Company direct. They have retained the Abner Doble Company as their consulting engineers.

PACIFIC COAST EXCURSIONS.

During June, July, August and September the Chicago and North Western Railway will sell from Chicago round trip excursion tickets to San Francisco, Los Angeles, Portland, Ore., (Lewis & Clarke Exposition), Seattle, Victoria and Vancouver at very low rates. Correspondingly cheap fares from all points in Canada. Choice of routes, best of train service, favorable stopovers and liberal return limits. Rates, folders and full information can be obtained from B. H. Bennett, General Agent, 2 East King St., Toronto, Ont.

P. PAYETTE & CO.

Manufacturers of Saw Mill and Engine Machinery, and all kinds of Marine Machinery.
PENETANGHISHENE, ONT



These Mules Cannot Break This Yarn

BECAUSE IT WAS MADE BY THE

Consumers Cordage Co., Limited

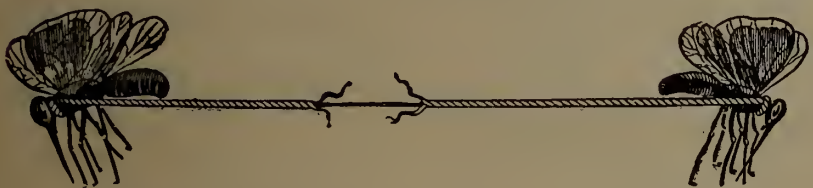

Poor Yarn is Dear at Any Price

We Manufacture

**Double and Single Lath Yarn,
Shingle Yarn, and Cordage**

Of Every Description

Our mills are equipped with the latest improved machinery for making extra long lengths of Transmission Rope.

CONSUMERS CORDAGE CO., LIMITED
Montreal and Halifax

WE ARE AFTER YOUR
Sprocket Chain

Trade on the Strength of

The large Stock we keep
The favorable Discounts we quote
The quality of our goods
20,000 to 30,000 ft. in our warehouse
at Winnipeg.

THE
Manitoba Iron Works
LIMITED

Manufacturers and Dealers in Saw-Mill Machinery,
WINNIPEG, MAN.

THE LUMBER MUTUAL FIRE INSURANCE COMPANY
BOSTON, MASS.

== **STRENGTH** ==

NET ASSETS, MARCH 31, 1904

\$646,352.94

== **ECONOMY** ==

DIVIDENDS TO POLICY HOLDERS

33 1/3 %

MAIL EXPIRING POLICIES WITH YOUR ORDER.

TRADE NOTES.

Cowan & Company, of Galt, Ont., have recently shipped woodworking machinery to Cushing Bros. & Company, Calgary, and Middleditch, Henderson & Wilson, High River, N. W. T.

The factory of the Canada Saw Company at St. John, N.B., is to be increased by the installation of new and improved machinery for the manufacture of the Hoe patent inserted tooth saw.

W. H. Nolan, proprietor of the Canada Machinery Company, has taken the agency for the Prescott Emery Wheel Company and will carry in future a large stock of emery wheels and grinding machines of all descriptions.

The Garlock Packing Company, of Hamilton, have removed their Montreal office to 371 St. James street, where they have greater accommodation and will keep constantly on hand a full supply of packings, pipe coverings and mill supplies.

D. K. McLaren, of Montreal, has recently secured the contract for belting for the Sherbrooke Lumber Company and has filled a large order from the Peri-

bonka Pulp Company. He reports that his St. John, N.B., branch is doing a large business with the mills in the Lower Provinces.

The Clark-Demill Company, Limited, have succeeded Clark & Demill, manufacturers of woodworking machinery, Galt, Ont. The new company have removed from Galt to Hespeler, where a fine new factory has been built. The officers of the company are: President, George D. Forbes; vice-president, J. R. Phin; secretary-treasurer, William E. Demill; managing director, William C. Clark.

We are advised by the New Century Refrigerator & Manufacturing Company, of Dundas, Ont., who suffered a severe loss by fire a couple of months ago, that they have rebuilt their dry kiln on a much larger and improved plan and commenced active operations about the middle of May. No doubt many of our readers will be interested in their hardwood veneer door and trims catalogue, which will be sent for the asking.

An agent from a foreign country who has been in the United States for the past few weeks, has just placed an order with the Marine Iron Works, Chicago, for a

very unusual type of what appears to be a thoroughly practical, exceedingly light draft, powerful, twin screw steamboat. The first of these boats will be small (55 feet long) made of galvanized steel throughout and fitted with two fore and aft compound condensing high-speed marine engines and a Roberts water tube boiler, burning crude oil, allowed 250 pounds steam pressure, the machinery being capable of indicating 70 h.p. The twin propeller wheels will work in tunnels of unique arrangement, entirely different from the orthodox type of "tunnel" boat. It is the opinion of the experts connected with the Marine Iron Works that the plan will prove very successful.



DO YOU USE IT?
BAUGHMAN'S BUYER & SELLER
THE HANDY BOOK FOR LUMBERMEN

Saves half the time and all the mistakes in figuring Invoices, Estimates and Inventory. Send for sample copy.

Flexible Cloth \$1.00
Flexible Leather 1.25

Sample Page Free. Address

H. R. H. BAUGHMAN
INDIANAPOLIS, IND, U. S. A.



GUARANTEED.

Sole Canadian Agents Prices Reduced
WATEROUS, BRANTFORD, CANADA

OILS

Manufacturers High-grade Cylinder, Machine and Sawmill Oils.

Calypsol Grease

for Sawmill Purposes a Specialty. Our products are made from finest Pennsylvania stocks.

We solicit your correspondence.

St. John St., MONTREAL. Commercial Oil Co.,
Offices and Works: Manchester, Eng. Hamilton, Ont.
Hamburg, Germany. Newark, N. J.
Chicago, Ill.

THE NEW

Dominion Saw Gummer

Saw Gummer Cutters of all Descriptions
MANUFACTURED BY

A. T. McLATCHIE, Car. inal, Ont.



Pail Manufacturers, Attention!
USE

FISHER'S PATENT POWER RIVETTING MACHINE

for rivetting your hoops.

Reduces your labour on rivetting by 40 to 50 per cent. Makes a much stronger joint, the laps being held firmly together, automatically, during process.

Manufactured by

The John McDougall Caledonian Iron Works Co., Limited
Montreal, Canada

Address all orders for rivetting machines and all correspondence in regard to same to
GEORGE W. FISHER, KEENE, N.H., U.S.A.

FRANK DENTON, K. C. HERBERT L. DUNN
W. MULOCK BOULTBEE.

DENTON, DUNN & BOULTBEE

Barristers, Solicitors, Notaries, etc.

National Trust Chambers. TORONTO

The Cook & Bros. Lumber Co.

Of Ontario, Limited
MILLS at SPRAGGE, Algoma Dist., Ont.
on "Soo" Branch C.P.R.

OFFICES: Manning Arcade, Toronto
Coristine Building, Montreal
And at Mills at Spragge.

THE MONTHLY JOURNAL

Concrete

Devoted to cement manufacture and the various forms of concrete construction.
\$1.00 a year; single copy 15c.
CONCRETE PUBLISHING CO., - Detroit, Mich.

MANUFACTURERS OF

White and Red Pine Lumber and Lath

Water Shipments

Please mention this paper when corresponding with advertisers.

1,000 Mershon Band Resaws

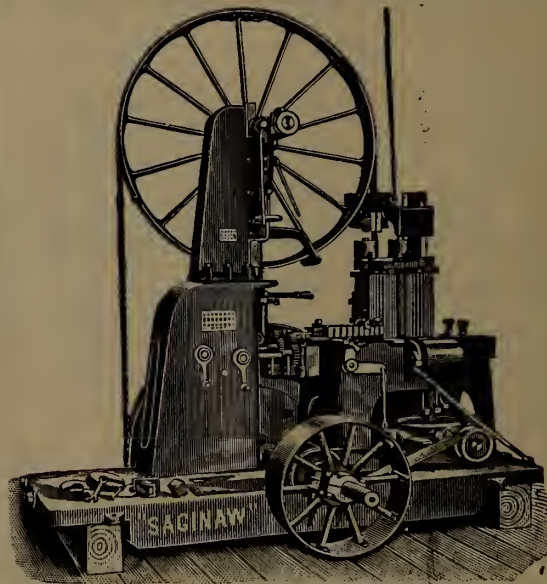

IN DAILY USE

BUY DIRECT AND GET

— THE —
GENUINE

W. B. MERSHON & CO.
Saginaw

Mich., — U.S.A.

Larrigans - Leggins - Horse Collars

All manufactured by ourselves from leather tanned by ourselves
Eminently suited to the LUMBER Trade

IF INTERESTED WRITE

THE R. M. BEAL LEATHER CO., LIMITED - LINDSAY, ONT.

Tanners of the Celebrated English Oak Harness Leather

Uncle Sam would not allow his battleships to be babbitted with inferior babbitt metal. New Battleship "Nebraska" is lined with Syracuse Babbitt. Always specify best. It is cheapest in the long run.

SYRACUSE SMELTING WORKS
MONTREAL NEW YORK SEATTLE

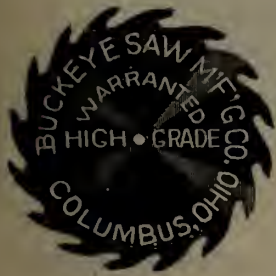

...BUCKEYE SAW M'FG. CO...

MANUFACTURERS OF
High-Grade Saws

Quick and careful work on Repairing.
All kinds of Mill Supplies.

REYNOLDS BROS., Proprietors
267 N. Water Street, COLUMBUS OHIO.

The Manitoba Gypsum Co.

MANUFACTURERS OF

LIMITED

HARDWALL PLASTER WOOD FIBRE PLASTER
PLASTER OF PARIS STUCCO ALABASTER
and All Kinds of Gypsum Products

The Only Plaster Co. in Western Canada

Quality of goods superior to any imported article, our mill being equipped with the latest improved machinery.

Dealers are invited to get our quotations before placing orders for Spring requirements

Office: 811 UNION BANK BUILDING, WINNIPEG

D. E. ROBERTS Lately in charge of the Plymouth Plaster Co., at Fort Dodge, Iowa.
Superintendent of Manufacture

WM. MARTIN
General Manager

Rodgers Iron Mfg. Co.

MUSKEGON, MICH.

Write to us and we will tell you all about it. Read what they say—hundreds more like them.

West Monroe, La., Oct. 13, 1904.

Rodgers Iron Mfg. Co.,
Muskegon, Michigan.

Gentlemen:—
We beg to hand you herewith, check to cover one edger and fixtures as per your invoice of July 15th.
We are very well pleased with the machine and the work it is doing.

Yours truly,



Tomahawk, Wis., March 3, 1905.

Rodgers Iron Mfg. Co.,
Muskegon, Michigan.

Gentlemen:—
Your favor of Feb. 24th is received; as we have just ordered another of your 72 inch Combination Edgers with Inch and Two Inch Gangs on them, should think this would be conclusive evidence of our satisfaction with your machines, as we already have three of them in operation.

Yours truly,

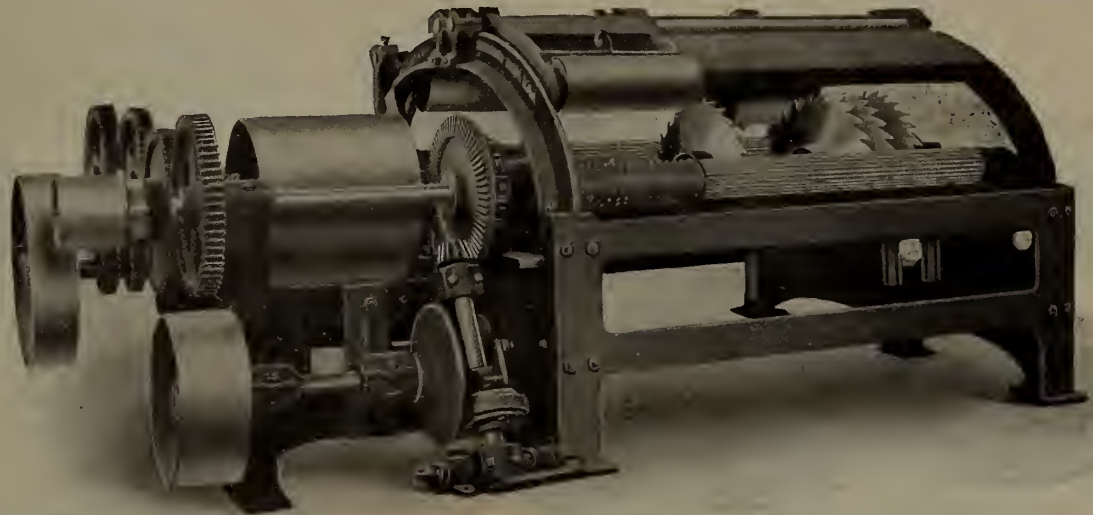

COMBINATION GANG EDGER WITH RIFT FLOORING ATTACHMENT

SHERMAN'S FLOORING MACHINES

PATENTED

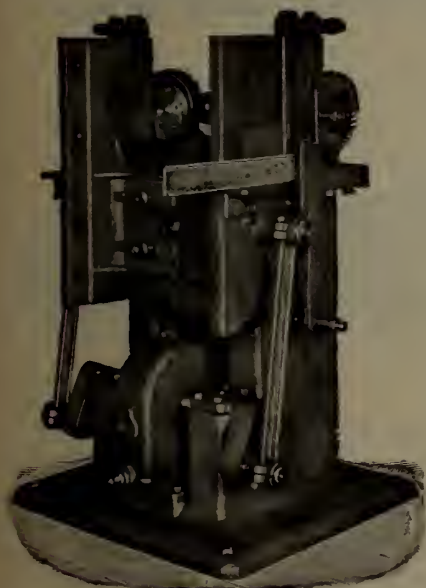

Above cut shows our End Matcher, the best machine in the market for end matching flooring strips. They do rapid and accurate work, and are durable—therefore used by leading flooring manufacturers. Make your flooring profitable by end matching it.

We Make the

SHERMAN SIDE BORING MACHINES

and the

SHERMAN FACE BORING MACHINES

To bore flooring while it is being run on the flooring machine. Write for circular and list of users.

W. S. SHERMAN CO.

Reliable Veterinary Remedies

No logging outfit is complete without a supply of reliable veterinary remedies. Getting the wrong kind means the loss of the use of your horses when time is valuable.

Johnson's Veterinary Remedies are guaranteed never to fail when used as directed. You get your money back if they ever do.

They are

Johnson's Horse Liniment No. 1.
A penetrating Alcoholic Liniment. Put up in one gallon jugs, with full directions, per imperial gal. \$4.50

Johnson's Horse Liniment No. 2.
A combination of the best oils used as liniments, imp gallon . . . \$3.00

Johnson's Horse Colic Remedy.
A sure and speedy cure for colic. Imperial gallon \$5.00

Johnson's Veterinary Healing Ointment.

Positively the best all-round healing ointment made. In use by the largest owners of horse flesh in Canada. Put up in 2 lb tins, each . . . \$2.00 or in 1/4 lb tins, per dozen . . . \$3.00

Johnson's Condition Powders. (Concentrated).
Put up in bulk, per lb 3c.

These goods being put up in bulk are more economical than others, as cost of bottling, etc., is saved.

CAMP REMEDIES.

In addition to our Veterinary Remedies we make a line of medicines for lumbermen, including a strong, penetrating liniment, healing ointment, cholera cure, liver pills, cough syrup, in fact anything in the form of Camp Drug Supplies. We know that there are no better remedies made than those we offer. There may be others nearly as good, but they lack our guarantee. Satisfaction or money back. A trade discount of 10% allowed off all orders amounting to \$100.

Send postal for printed matter.

A. H. JOHNSON
Wholesale Druggist
Collingwood, Ont.

WHY NOT EDGE TWO BOARDS IN PLACE OF ONE in the same time?

A Side Edger removes but one edge of a board at a time. The same is true where the edging is done on the main saw.

A No. 1 or 2 TOWER 2-saw Edger, Improved, removes both edges, and if one edge of the board is already straight, produces two fully edged boards in one operation. A No. 4 TOWER 3-saw Edger, Improved, delivers two or three perfectly edged boards at one pass, according to whether the lumber reaches the machine with both edges crooked or one edge straight.

If you have no gang edger, you are Producing but One Board where you might produce Two

The Gordon Hollow Blast Grate Co., Greenville, Mich.

Established 1889

The largest manufacturer of Blast Grates, Edgers and Trimmers in the world.

THE DYMENT FOUNDRY CO.

BARRIE, ONT.

Manufacturers of

ENGINES, BOILERS, STEAM FEEDS

AND A COMPLETE LINE OF

SAW, SHINGLE AND LATH MILL MACHINERY

Can ship mills in a week's notice. Write us for prices and catalogue.

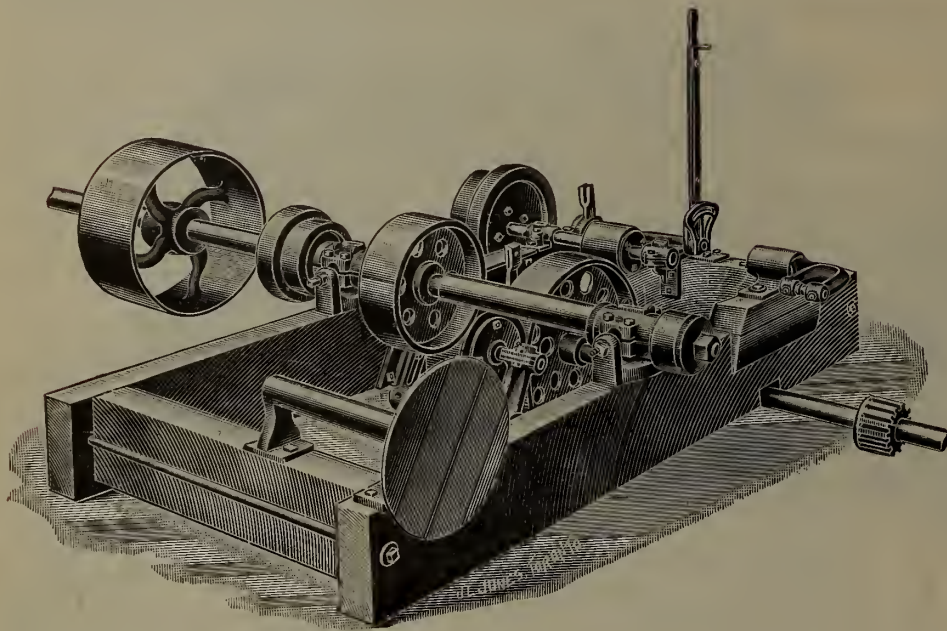
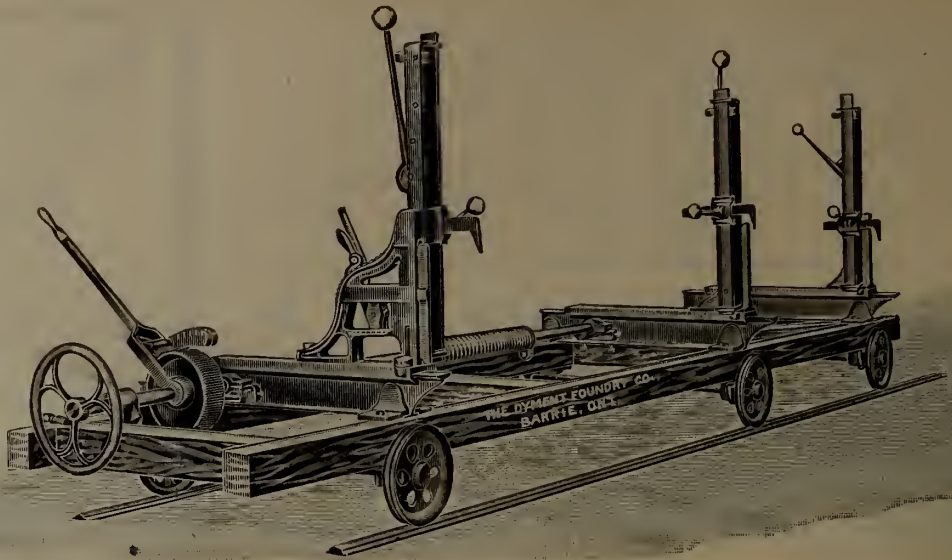

This is a light running Carriage and is quite suitable for small mills. Its capacity is about 15,000 feet per day. The wheels are 14 inches in diameter. The axles are $1\frac{3}{4}$ inches in diameter and go across frame. They are fitted with self-oiling boxes. The bunks are of steel. Blocks will recede 38 inches. An overset lever is supplied when desired, also spring receder and band brake wheel.

The feed on this frame is self-contained and can be used for either rope or rack and pinion. All the frictions have 7 inch face, two of them are made of paper, the other two of iron. The mandrel is made of steel and is 3 7-16 inches in diameter. The mandrel pulley is made in different sizes so as to suit the speed and width of drive belt. If desired this pulley may be put inside of frame.

WE MANUFACTURE AN IRON SAW FRAME

THE "CANADIAN" SHINGLE AND HEADING EDGER

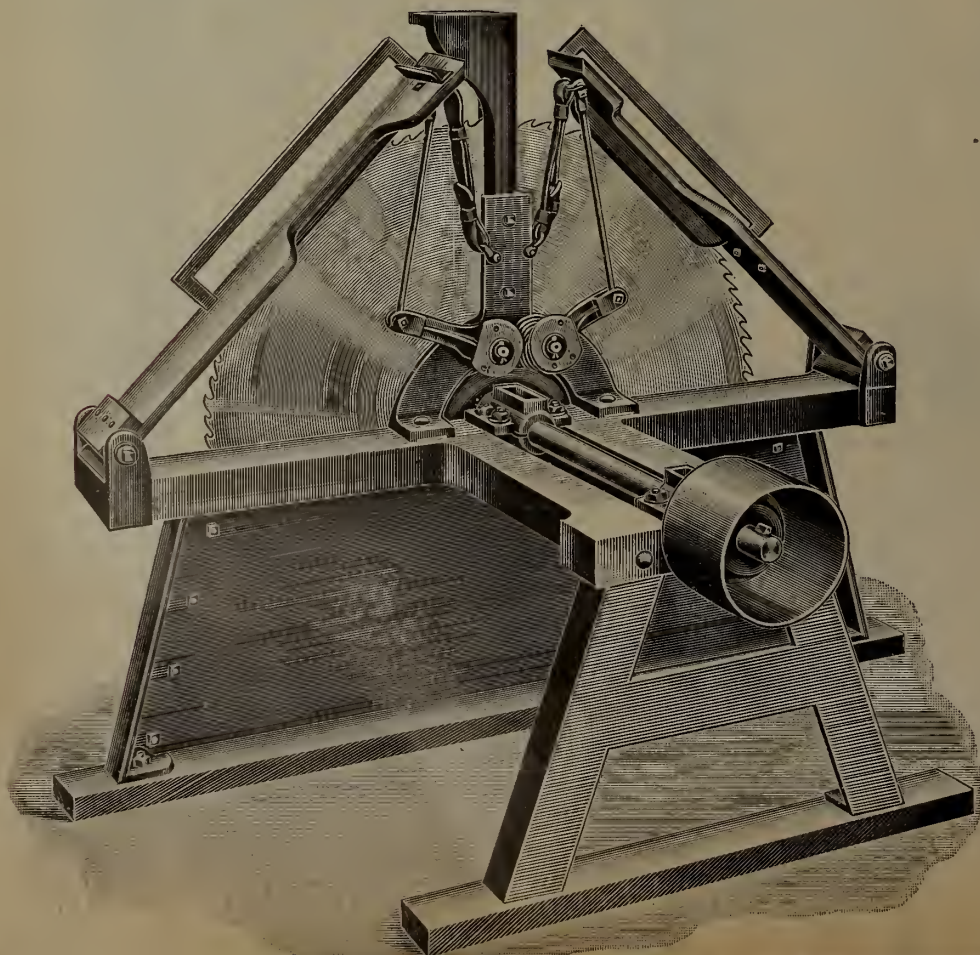

Has solid iron frame. Made for two operators. Drive pulley, unless otherwise ordered, is 8 inch diameter for 6 inch belt. Heavy steel saw arbor with extra long bearings. The saw is 40 inches in diameter, 16 gauge, 100 teeth, and should run 1,600 revolutions per minute. The saw can be easily removed for filing when necessary.

The Spring Boards are fitted with guards to protect the operator from the saw. The springs can be easily adjusted for any desired tension.

This machine is a "timber saver" and will make more No. 1 Shingles from same quantity of timber than any wheel jointer in existence. Mill men who have once used it will not have any other.

For capacity, removing sap-wood, rot, knots, or other imperfections, or making parallel shingles, and economy of stock, it has no equal.

Send for Catalogues of Saw and Shingle and Lath Mill Machinery. Complete outfits furnished.



F. J. DRAKE,
BELLEVILLE - ONT.

ATKINS ALWAYS AHEAD!



QUALITY IS THE THING!

Substance, not the Shadow of Quality

Characterizes the Silver Steel Saws bearing the celebrated "AAA" trade mark. Superiority of material, our patent process of tempering, perfection of grinding and experience and skill in workmanship are the leading features in the make-up of an Atkins Saw. These qualities insure perfect running saws and satisfaction to the user. The highest intrinsic value ever offered and the most efficient service possible to obtain are secured when you purchase an Atkins Saw. A trial is convincing proof. Think it over and let's have your order now.

Our Machine Knives, too, are made with a view of retaining you as a permanent, satisfied patron. What more can we say?

Mill Supplies of every description. Write for our 1905 Saw and Saw Tool Catalogue and Sawyer's Hand Book. It's free.

E. C. ATKINS & CO., Inc.,

Leading Manufacturers of Circular, Band, Cross-Cut, Hand and Wood Saws, Etc.

Factories and Home Office,
Indianapolis, Ind.

Canadian Branch,
56 King St. East, Toronto, Ont.

THE E. L. PURVIS CO.,
18 COLBORNE ST., TORONTO, ONT.



PIPE AND BOILER COVERINGS

Asbestos Mineral Wool
and all kinds of Fireproofing

Material Agents for

FAMOUS MICA COVERINGS

Fire Clay Products

THE GLENYARDS FIRE CLAY CO.

BONNYBRIDGE, SCOTLAND.

Cablegrams: Glenyards, Bonnybridge.

Codes used, A.B.C. and Glenyards.

Manufacturers of all kinds of Fire Clay Goods, Ganister and Silica Goods, for Iron and Steel Works and Gas Works, including Boiler Seating Blocks and Covers of all sizes. Ground Fire Clay, Ganister and Silica in all kinds of Packages

Don't Hurry---Just Keep Moving

Operators of Shaping Machines—and others who know—will tell you that one-half of their time is devoted to "fitting up" and "getting ready."



OUR "SOLID STEEL SHAPER CUTTERS"

(GUARANTEED)

Are used by manufacturers who by experience know that the "first cost" is very small compared with the "continual cost" when "open heads" are used. OUR CUTTERS are always ready for use, which means "always something doing" on the Shaping Machine.

In ordering—send sample of mould, diameter of spindle, and size of collars.

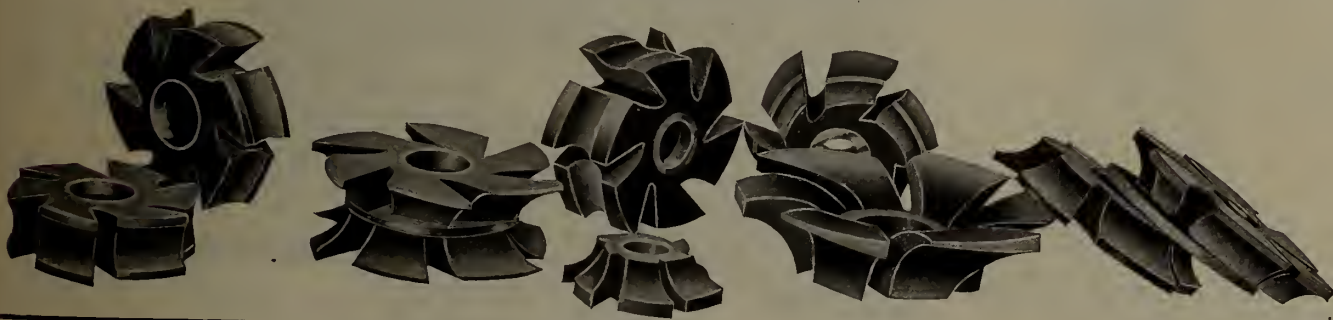

Furniture City
Tool Company

189 CAMPAU STREET, GRAND
RAPIDS, MICH., U.S.A.

AGENTS—
Harron, Rickard & McCone, San Francisco, Cal.
Schuchardt & Schutte, Berlin, Germany

The Gravenhurst

"BOSS" SHINGLE MACHINE

The Best Machine on the Market

The Simplest in Construction of any Machine Built

We build Shingle Machines both Horizontal and Vertical
We also build All Kinds of Saw Mill and Shingle Mill Machinery.

Send Us Your Orders, Large or Small—We Can Fill Them

Write for Catalogue

B. R. MOWRY & SONS
GRAVENHURST, ONT.

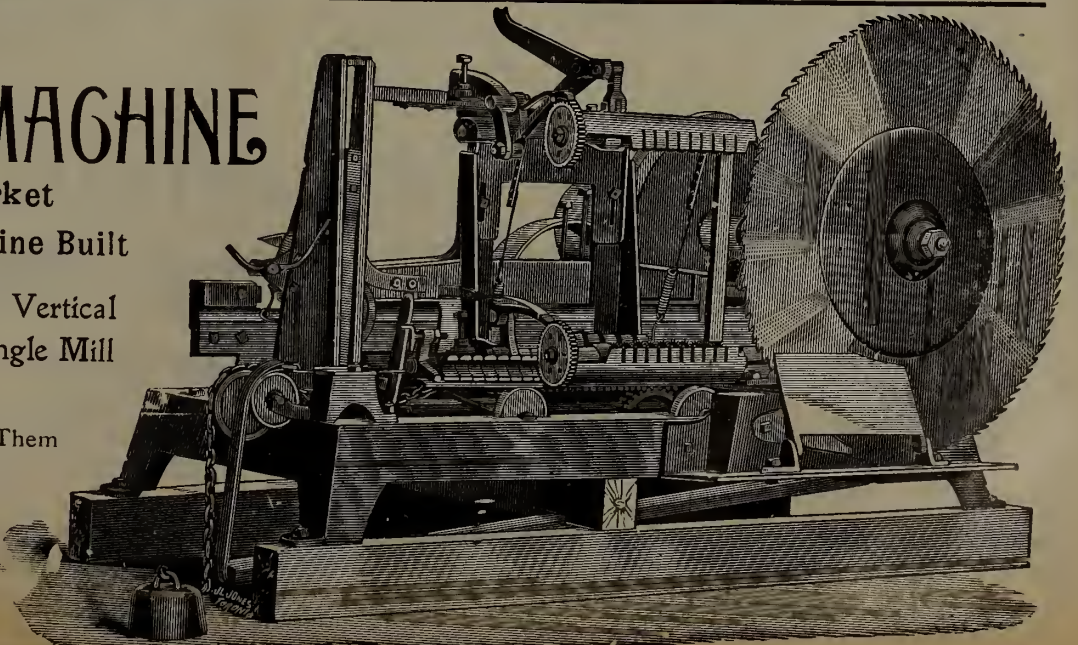

Can you afford to hesitate about investigating the merits of any tool which will save you money?

OUR AMERICAN NO. 1 BAND RIP SAW
is such a machine

Drop us a line and we will tell you of its many advantages.

We are manufacturers of the largest and most complete line of machinery in the world.

Ask
for Catalogue.

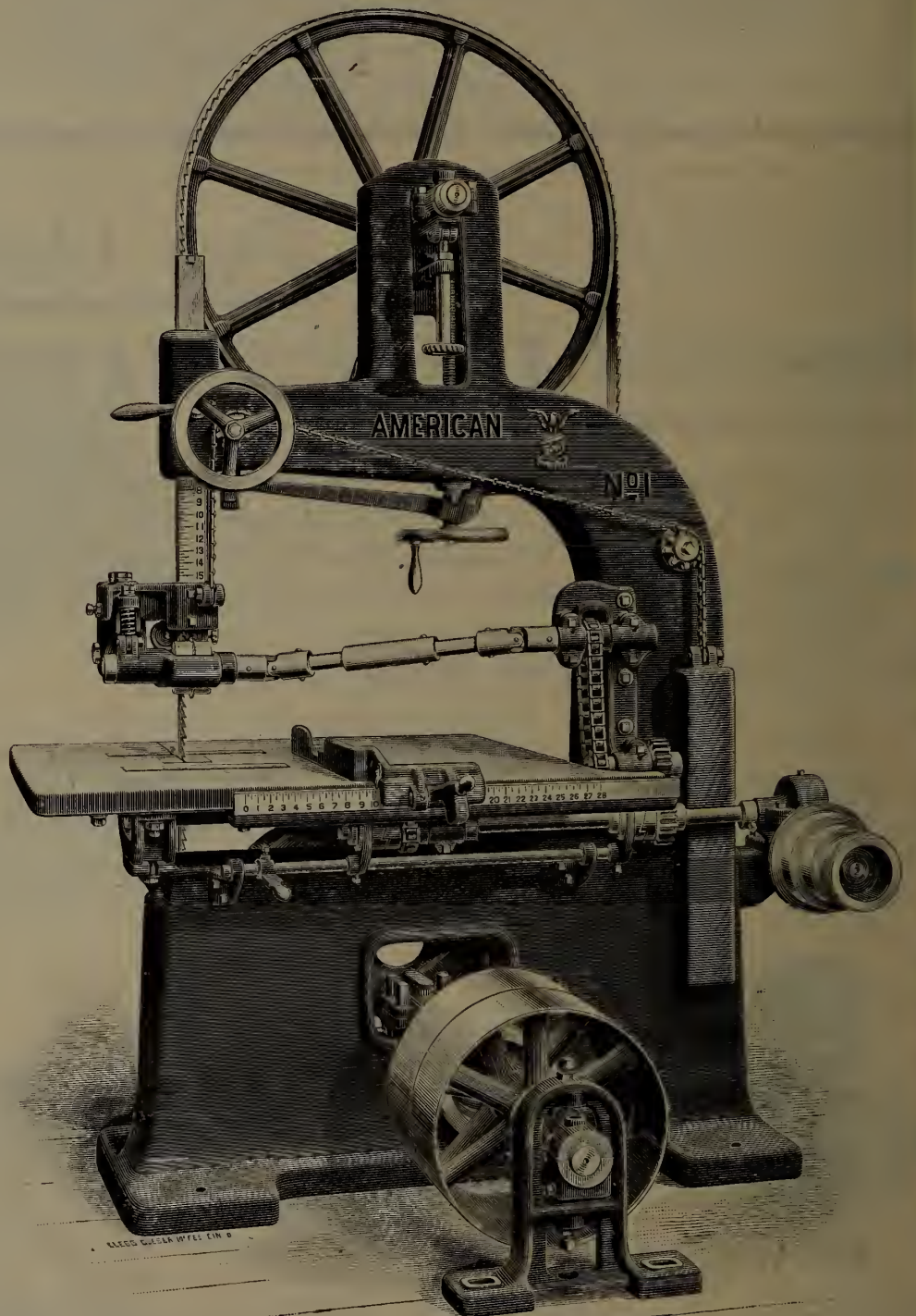

**American
Wood-Working Machinery
Company**

136 Liberty Street, NEW YORK

Sales Agent—THE CANADIAN FAIRBANKS CO., MONTREAL



Dundas Lumberman



A New Axe tempered by a new process which enables us to submit to any lumberman three or more samples of Axes, all different degrees of hardness, and on a selection being made we will guarantee to furnish any number all exactly the same temper as sample chosen.

THE DUNDAS AXE WORKS
Dundas, Ont.

FOR THE CAMP TABLE

- Mess Pork
- Short Cut Pork
- Plate Beef
- Dressed Fresh Beef
- Long Clear Bacon, Butter, Cheese, &c.
- Smoked Hams
- Roll Bacon
- Pure Lard
- Pork Sausage

Write us for Special Prices on Car Load Lots.

THE PARK BLACKWELL CO., L'T'D

PORK AND BEEF PACKERS
TORONTO

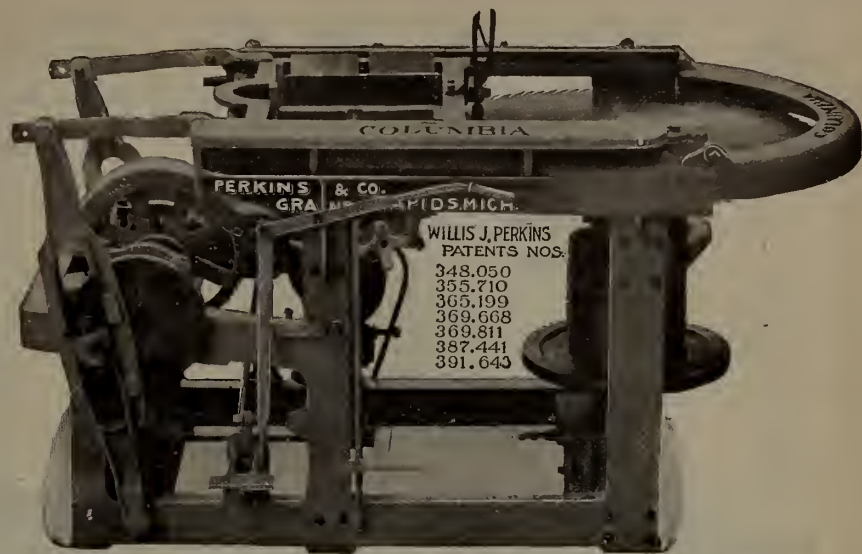

THIS IS THE SHINGLE MACHINE

You need if greatest Capacity, Strength, Ease Economy of Operation is what you're looking for in a Shingle Machine.

THE COLUMBIA SHINGLE BLOCKER

Will produce 1,000 additional shingles from every 1,000 feet of logs—the only machine on the market capable of doing it, due to its point regulation. Write us about this perfect shingle producing machine, or about anything in the line of shingle machinery. We build a complete line from \$150 up.

PERKINS & GO. - Grand Rapids, Mich.



MANUFACTURERS OF
INSERTED, SHINGLE, AND ALL SOLID-TOOTH CIRCULAR

SAWS

WHAT THE LEADING MILLMEN SAY OF OUR SAWS:

A. J. BURTON SAW CO., VANCOUVER. PORT MOODY, B. C., MARCH 25TH, 1905.

DEAR SIRS,
We wish to compliment you on the 65 saws we purchased from your company They comprise practically all kinds, from a lath saw to a 64" inserted tooth, and they are all giving excellent satisfaction, equal to any of the saws furnished us in the past by any of the old established makers.

Wishing you every success and believing that you deserve it.
We are yours truly,
THE CANADIAN PACIFIC LUMBER CO., LTD.
(SIGNED) per P. D. ROE, MANAGING DIRECTOR.

HOE BITS AND SHANKS AND ALL FILE-ROOM SUPPLIES
OLDHAM BAND SAWS

Repairs Executed Promptly. Inserted Tooth Saws Remilled and Refitted

Lumbermen, Attention!

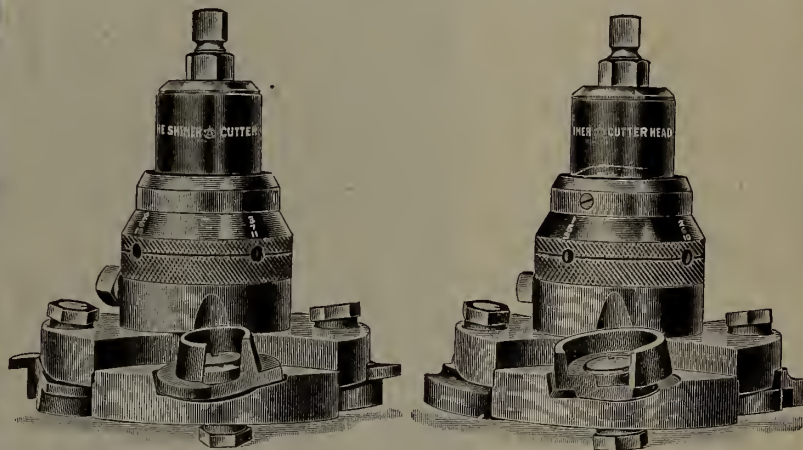

YOU manufacture lumber as a business, and use matching and moulding machines which should be equipped with The Shimer Cutter Heads to receive their best service. The convenience of these tools in working Flooring, Ceiling, Siding, Ship Lap and Jointing is being demonstrated every day from the fact that more than 100,000 of them are in use throughout the United States and foreign countries. If you do not use them, ask your neighbor or any practical mill man concerning their convenience. Don't be prejudiced—ask.

Then send to us for full particulars and learn the low prices at which we can fit you out with the best Steel Forged Cutter Heads that can be produced. Don't forget that we send them on trial to responsible mill men anywhere; they can be returned at our expense if they don't prove to be the greatest time and labor saving tools for the purpose.

Our Catalogue will give you a lot of information about The Shimer Cutter Head, and we will mail it free to any address.

... Address ...

SAMUEL J. SHIMER & SONS,
MILTON, PA.

ADAM HALL,

PETERBOROUGH, ONTARIO
CANADA

MANUFACTURER OF

STEEL RANGES

For Lumbermen's and Railway Camps, Boarding Houses and Hotels

The Lumberman Heater

36 Inch Lumberman Heater

42 Inch Lumberman Heater

48 Inch Lumberman Heater

This Heater is used in heating Lumbermen's Camps, Boarding Houses, School Houses and large buildings.

The body of the Heater is made of Heavy Boiler Plate. The ends are made of Heavy Cast Metal, with a large Fire Door.

It is a perfect Heater, and very durable.

We have been manufacturing Steel Ranges and Heaters for Lumber Camps for the past Twenty-four Years, and have supplied the wants of nearly all the Lumbermen in Quebec, Ontario and Manitoba—they are unexcelled for Baking and Cooking, and are strong and durable.

This No. 10-25 Range with 25 Gallon Copper Reservoir is the one we sell the most of, owing to the convenience of having a supply of hot water at all times. Will cook for 50 to 60 men. Weighs 450 pounds.

Write for Catalogue and Price List.

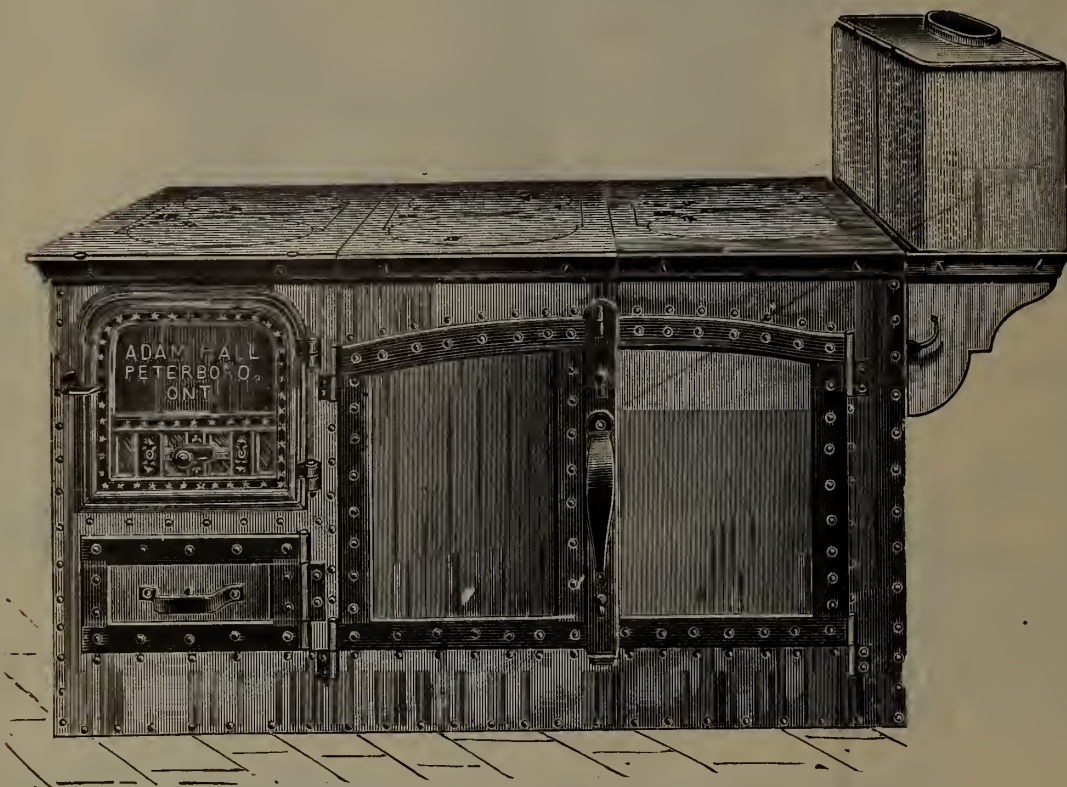

Lumbermen's Six Pot Hot Range with Reservoir.

IMITATED BUT NEVER EQUALLED

40,000

Running in
Every Kind
of Timber



Perfect
in Material,
Workmanship
and Temper

GET THE GENUINE HOE CHISEL-TOOTH SAW

MADE ONLY BY

R. HOE & CO., 504 to 520 Grand Street, NEW YORK, N. Y., U.S.A.

Perfect Swing Shingle Mill

Fitted with our "Automatic Trip."

Best Swing Shingle Machine on the Market today for cutting Shingles, Headings, Etc. . .

It will pay you

to write for description and price before placing your order.

We also Manufacture a complete line of . . .

SAW MILL MACHINERY, ENGINES AND BOILERS

THE
Owen Sound Iron Works Co. LIMITED
Owen Sound, Ont.

SEND FOR CATALOGUE

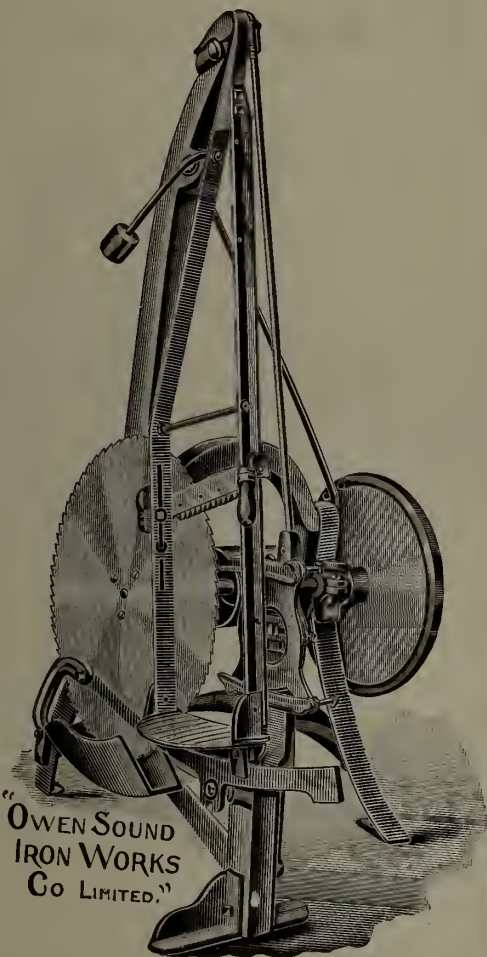

"OWEN SOUND IRON WORKS CO LIMITED."

RUBBER BELTING

For
Transmitting
Elevating
and
Conveying



Rubber
Hose
for
Water
Steam
Air
Suction
Fire
Protection

THE GUTTA PERCHA & RUBBER MFG. CO. OF TORONTO, LIMITED.

HEAD OFFICES: 47 YONGE STREET, TORONTO, CAN.

Branches: Montreal, Winnipeg.

New 200 Page Green Book
1904 EDITION.

"Saw and Knife Fitting Machinery and Tools"

MAILED FREE ON REQUEST.

A Book for Mill and Factory Managers, Superintendents, Foremen and Saw Filers.

BALDWIN, TUTHILL & BOLTON,
GRAND RAPIDS, MICH., U.S.A.



B. T. & B. Full Automatic Knife Grinder. Style D

SAW AND KNIFE FITTING

THE NEW B. T. & B. MANUAL

Revised edition. 144 pages. Copiously illustrated and Durably Bound. Is an exhaustive treatise on the care of Saws and Knives.

A Practical Book for Saw Filers.

Mailed Postpaid on Receipt of Price

\$2.00

THE "B. T. & B." LINE

NEED ANYTHING ?

- Sharpeners, Swages,
- Stretchers, Shapers,
- Side Files, Shears,
- Retoothers, Brazing Machines, Filing Clamps, Lap Grinders, Lap Cutters, Patch Machines, Crack Drills, Hammering Benches, Bench Grinders, Band Filers, Band Setters, Pulleys and Stands, Brazing Forges, Saw Sets, Saw Gauges, Swage Bars, Upsets, Straight Edges, Tension Gauges, Back Gauges, Leveling Blocks, Anvils, Hammers, Speed Indicators, Emery Dressers, Knife Grinders, Knife Balances, Shingle Saw Grinders, Burr Gummars, Post Brackets, Stretcher Bench Brackets, Cutters, Marking Stamps, Saw Guides, etc.

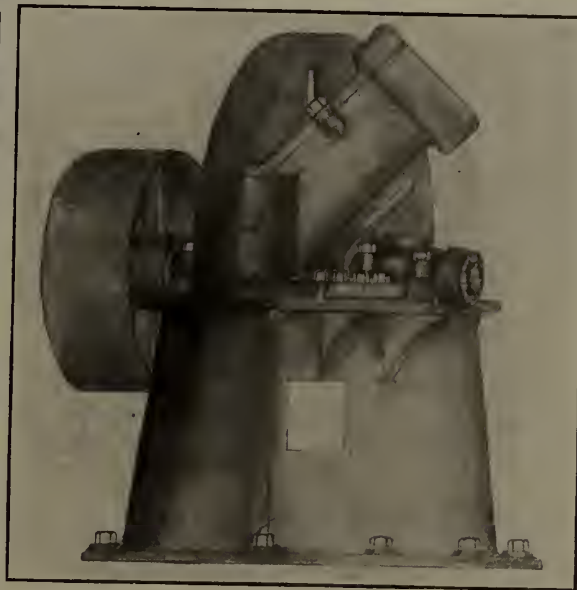

Pat'd.-Apr. 23, 1901.

Made in larger sizes for chipping pulp wood & large saw mill refuse

40 IN. IMPROVED "HOG"

For cutting Lath Mill, Planing Mill and Box Factory Refuse into fuel chips, no matter whether wet or dry. Will feed stuff through at the rate of 40 ft. per minute. Takes less power to drive than any other Hog made. A 6" belt drives it. Has but three knives to be taken care of.

For prices and further information, address

I. N. KENDALL, 203 Bridge St., OTTAWA, ONT.

PORTABLE SAW MILLS

IN MANY INSTANCES ARE INDISPENSABLE

OUR EXPERIENCE IN BUILDING THEM EXTENDS OVER HALF A CENTURY

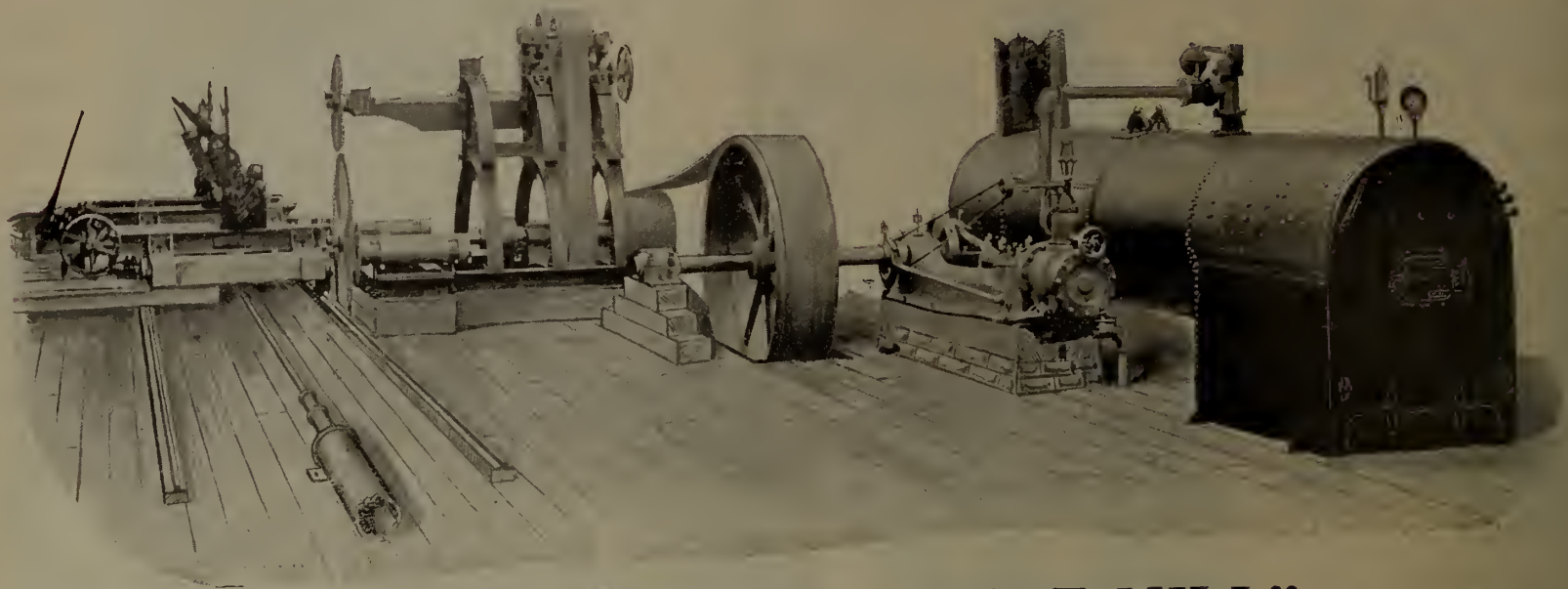

100 H. P. "PACIFIC COAST MILL"

With No. 4 Saw Frame, 72 in. Lower and 56 in. Upper Saw; No. 6 Girder Steel Unbreakable Carriage, opening 72 inches from Saw—all portions of Carriage either Rolled or Cast Steel, Direct-Acting Steam Feed, etc.

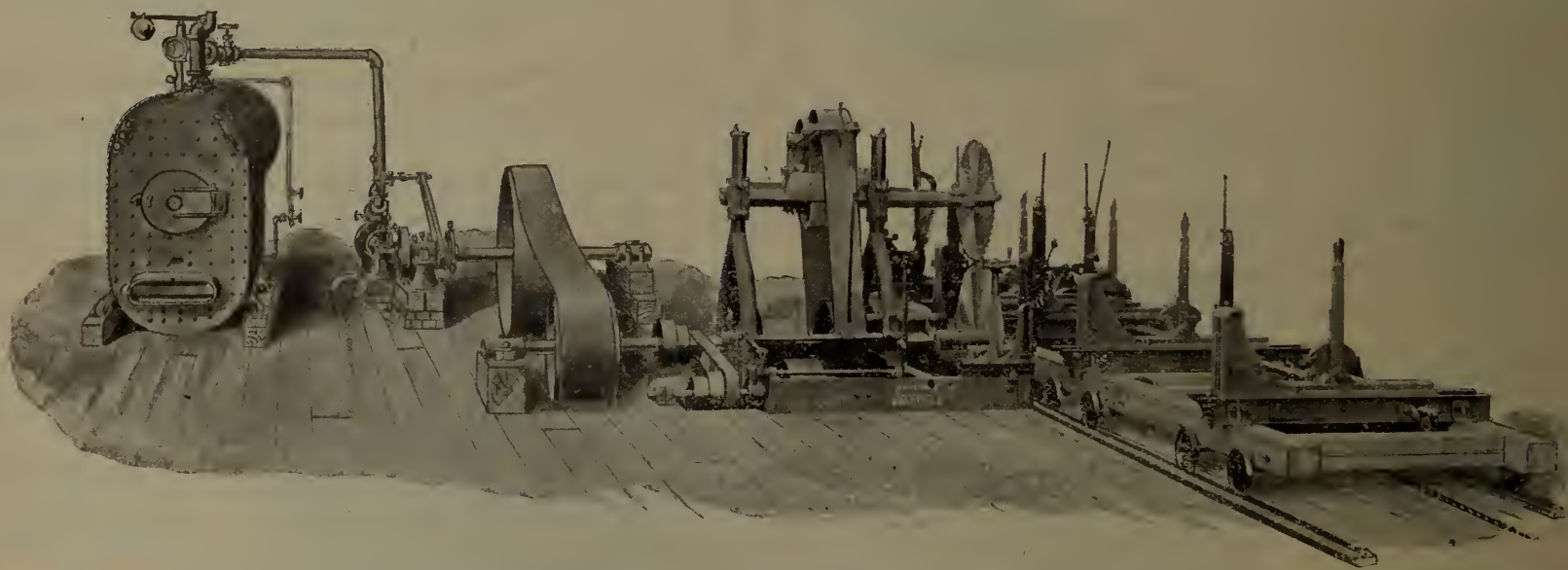

60 H. P. "ONTARIO AND WESTERN MILL"

With No. 3 Saw Frame, having 12 inch face Friction Feed Works, taking 60 inch Lower Saw and 40 inch Upper Saw. A No. 3½ 5 Block Girder Steel Carriage opening 50 inches from Saw, with Peel and Reliance Cant Hook Double Spud Dogs—Rope Feed, Automatic Coupling in Carriage between 3rd and 4th blocks—extras when required Bull Wheel, Slab Saw, Single or Double Edger, Trimmer, Live Rolls, Planer and Matcher.

The above are our Large Portable Saw Mills.

We manufacture all sizes down to 12 H. P., with Saw Irons of Smallest and Lightest Dimensions.

WRITE US FOR PRICES AND CATALOGS

AGENCIES:

WATEROUS ENGINE WORKS CO.
H. B. GILMOUR,

WINNIPEG, MAN.
VANCOUVER, B. C.

WATEROUS, Brantford, Canada

NATURAL DRAFT MOIST AIR . . . DRY KILNS

LUMBER TRUCKS and TRANSFER CARS

Write for prices and particulars of the most simple and efficient Natural Draft Dryer on the market. Testimonials and list of users sent on application. Every square inch of heating surface is utilized to the uttermost and perfect ventilation and circulation is obtained by a very simple arrangement of ducts. Write for particulars to

SHELDON & SHELDON, GALT, ONT.

FORMERLY McEACHREN HEATING & VENTILATING CO.



Experimenting with Dry Kilns is an Expensive Luxury

Why keep on using a Kiln that has to be regulated with dampers, chimneys and complicated fans. Put in a Morton Automatic Moist Air Kiln and your Dry Kiln troubles will be ended. We do not sell a man a Dry Kiln to dry Mahogany and then tell him it will dry Basswood staves. Our thirty years experience in the Dry Kiln business yours for the asking.

Write to-day for Illustrated Catalogue "C"

The A. H. Andrews Co.

174-176 Wabash Avenue - - - CHICAGO, U.S.A

Eby Machinery Co., Western Agents, 17-19 Main St., San Francisco, Cal.

H. G. Boardman, Eastern Agent, 1170 Broadway, New York.

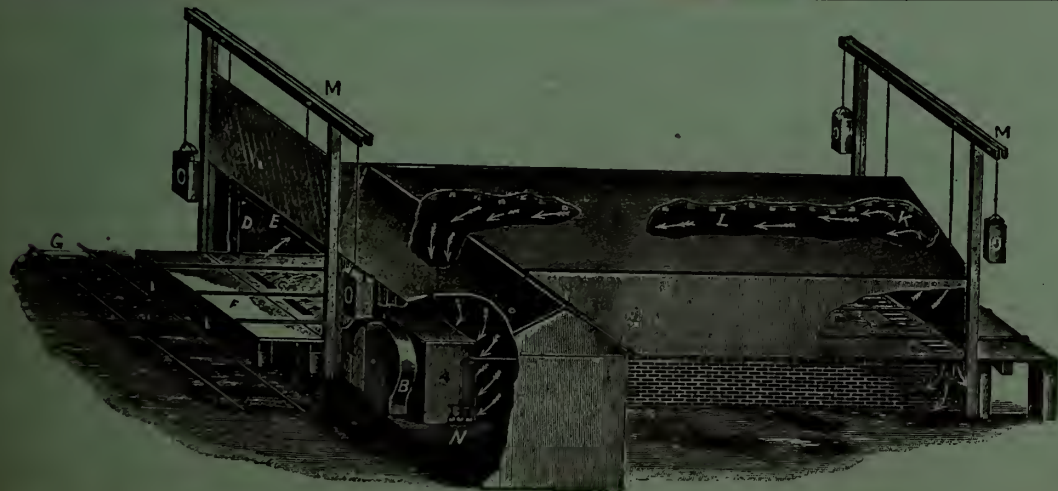

McEACHREN HEATING & VENTILATING COMPANY, GALT, CANADA

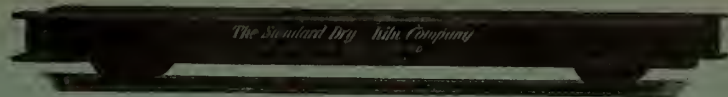

THE HIGHEST ACHIEVEMENT IN TRUCK CONSTRUCTION

Standard Dry Kiln Trucks are best for your plant because they run more lightly, give less trouble and last longer than any other truck on the market. This we prove and guarantee.

Not only do they possess every modern feature of truck construction, but a number of the most valuable points about them are patented by us and cannot be reproduced in other trucks.

Standard Trucks have malleable iron wheels and spreaders; channel steel frame; steel rollers with cone-shaped ends that minimize the friction; lath-cut axles with milled ends, and many other advantages that are explained and illustrated in our printed matter.

Write for our Catalogue "D" and learn more about these better dry kiln trucks.

The Standard Dry Kiln Co. Indianapolis, Indiana

SAW MILL OPERATORS are finding that

"MIDLAND" BEARING METAL

is all that WE CLAIM FOR IT

and then it is sold for only

15 CENTS A POUND

You will be pleased if you will give us a trial order.

GEORGIAN BAY ENGINEERING WORKS

Midland, Ontario

FOR DRY KILNS

that will season lumber of all kinds and under all conditions, whether partially air-seasoned or green from the log, in shortest time and at least cost, entirely free from checking, warping or case hardening,

Write to—

HUTHER BROS. PATENT GROOVER OR DADO HEAD
For cutting any width groove from 1/4-inch to 2 inches or over

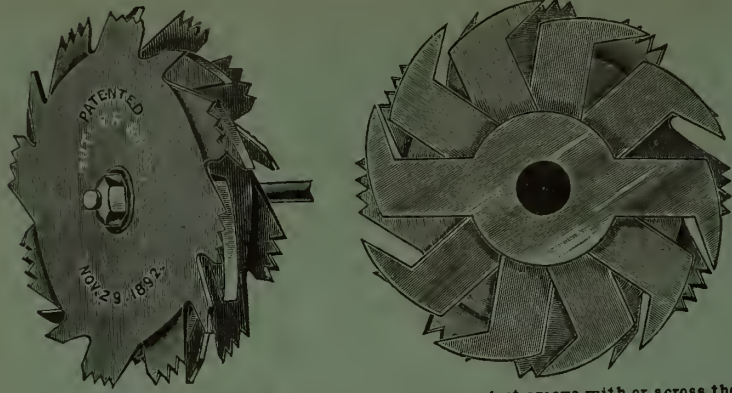

Can be used on any Circular Saw Mandrel. Will cut a perfect groove with or across the grain. This is the only Dado Head on the market that gives entire satisfaction on all classes of work. No screw adjustment. For different width grooves, simply remove or add inside cutters. Sold by builders and dealers of woodworking machinery in all parts of the United States. Will send on approval, in competition with any other make on the market; if not the best return at our expense HUTHER BROS., Platt Street, ROCHESTER, N.Y., manufacturers of Circular Saws, Morgan Pattern Lock-Corner Box Cutters, Concave Saws, etc.

Rice Lewis & Son,

Dealers in _____ LIMITED

BAR IRON AND STEEL

BOOM AND LOGGING CHAINS MADE TO ORDER

TORONTO

Write for Prices.

Steam, Power and Centrifugal Pumps, Condensers, Travelling Cranes.

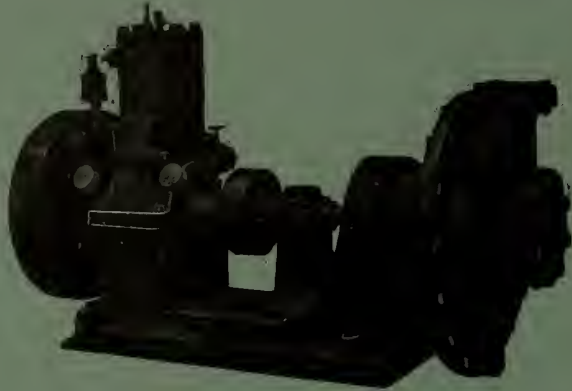

The cut illustrates our direct connected Gasoline Engine and Centrifugal Pump.

Send for Catalogue.

THE SMART-TURNER MACHINE COMPANY, LIMITED. HAMILTON, Canada.

Galt Machine Knife Works



MACHINE KNIVES OF EVERY DESCRIPTION FOR Woodworking Machines ... Send for Price List... The Peter Hay Knife Co., Limited - Galt, Ont.

CRESCENT MACHINERY

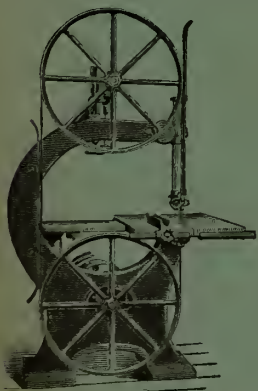

Quality is all right. So's the price.

- Band Saws
- Jointers
- Saw Tables

Very low price on BAND SAW BLADES Catalogue tells the rest.

H. W. PETRIE Dept. C. M. TORONTO, ONT.



THE LEATHER BELT THAT'S KNOWN OUR "EXTRA"



MONTREAL WINNIPEG

TORONTO VANCOUVER

PINK LUMBERING TOOLS

The Standard Tools

In Every Province of the Dominion, New Zealand, Australia, Etc.



Pink Round Bill Peavey, Handles in Split Maple

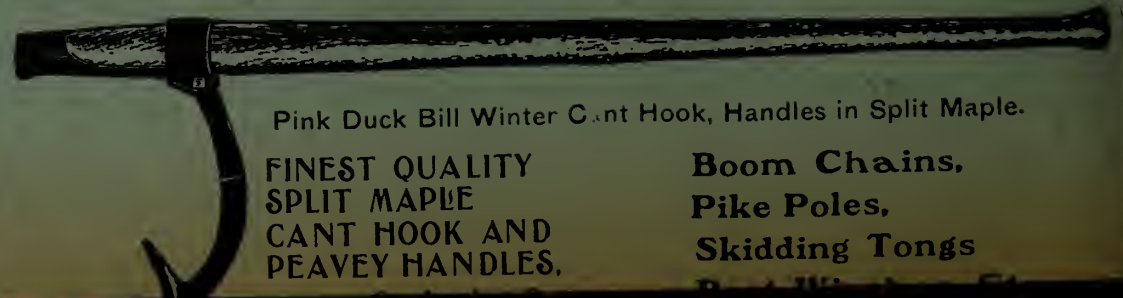

Pink Duck Bill Winter Cant Hook, Handles in Split Maple.

FINEST QUALITY SPLIT MAPLE CANT HOOK AND PEAVEY HANDLES.

Boom Chains, Pike Poles, Skidding Tongs

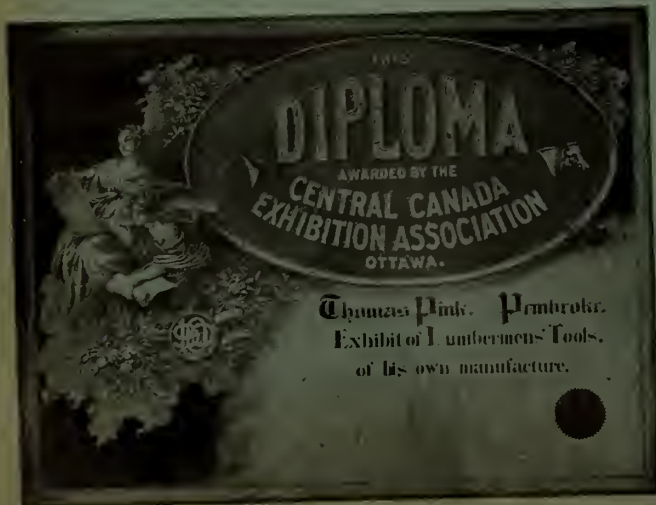

DIPLOMA AWARDED BY THE CENTRAL CANADA EXHIBITION ASSOCIATION OTTAWA.

Thomas Pink, Pembroke. Exhibit of Lumbermen's Tools, of his own manufacture.

THOMAS PINK

THE CANADA LUMBERMAN AND WOOD-WORKER

REACHES REGULARLY THE MANUFACTURERS AND BUYERS AND SELLERS OF TIMBER PRODUCTS IN EVERY PART OF CANADA AND LEADING IMPORTERS ABROAD

VOLUME XXV. }
NUMBER 7.

TORONTO, MONTREAL — JULY, 1905 — WINNIPEG, VANCOUVER

{ TERMS, \$1.00 PER YEAR
Single Copies, 10 Cents.

LUMBERMEN'S LOG STAMPS
STEEL & RUBBER STAMPS, BRASS STENCILS, ETC.
THE SUPERIOR MFG. CO.
COR. BAY & ADELAIDE STS. TORONTO, CAN.
Write for Catalogue.

JNO. S. FIELDING, C. E.

WATER POWERS AND DAMS

Room 2, 15 Toronto Street - TORONTO

BROWN'S PATENT STEEL WIRE CHAIN

If you are interested in Chains examine carefully the perfect mechanical construction of the Brown's. It is the most perfect chain made. We make it in 13 sizes.

Correspondence solicited. We send cuts with table of breaking strain, sample, etc., upon request.

The B. GREENING WIRE CO., Limited
HAMILTON, ONT. MONTREAL, QUE.



The Canada Saw Co. LIMITED
Factories at: Ottawa Montreal Toronto St. John, N. B.
Sandvik Swedish Steel
Band, Gang and Circular Saws
P. M. FEENY, Manager.

A Good Thing

A good thing is always worth the money. This is true of our belting.

J. L. GOODHUE & CO.,
DANVILLE, QUEBEC.

D. K. McLaren
GENUINE
Oak Belting
MILL SUPPLIES

751 Craig St., Montreal,
196 King Street West

WOODS LIMITED

Wholesale Manufacturers of . . .

LUMBERMEN'S AND CONTRACTORS' SUPPLIES

INCLUDING

Tents, Flags, Awnings, Tarpaulins, Clothing, Overalls, Shirts, Mitts, Underwear, Blankets, Axes, Moccasins, Woods Celebrated Eider Down Sleeping Bags

WOODS BUILDING - OTTAWA, CAN.

SEND FOR **H. W. PETRIE'S**
MONTHLY STOCK LIST
NEW & 2ND MACHINERY
TORONTO, CANADA

DICK'S BELTINGS



Never is affected by wetness, and does not stretch

Excels in Transmission Power

Always Uniform.

LARGE STOCK ON HAND

WRITE TO SOLE AGENTS:
J. S. YOUNG, 14 Hospital Street
MONTREAL

WIRE ROPE

AND FITTINGS IN STOCK

W. H. C. MUSSEN & CO.
MONTREAL, QUE.

LIGHTS RAILS
(New and Relaying)
PAINT SPRAYERS
ATLAS CAR MOVERS

THE E. R. BURNS SAW CO.
TORONTO, ONT.

MANUFACTURERS OF HIGH-GRADE

Circular and Long Saws
UNEXCELLED
SHINGLE SAWS



The Wm. Hamilton Mfg. Co., Limited

Builders of a Complete Line of

SAW MILL MACHINERY

We are specialists in the building of sawmill machinery—we have been making it, and making it well, for nearly fifty years.

Surely our machines must have merit—must have lived up to all our claims, or we would not be in business to-day.

Back of every machine we sell is our guarantee against its failure due to defective material or workmanship, and our warranty of its successful operation.

All our machines are of simple design and enduring construction.

We are specially well equipped for handling repair jobs, and can give your orders prompt attention.

Can we not send you our catalogues?
Write Department L for them.

Our Line Includes

Engines and Boilers

Band Mills

With Weight or Steam Tension

Gangs

Carriages

Husk Frames

Log Handling Machinery

Edgers

Trimmers and Slashers

Steam, Hand and

Power Set Works

Lath Mill, Shingle Mill

and Filing Room Machinery

Twin Circulars

Tie Mills

Burners

Head Office and Works: PETERBOROUGH, ONTARIO

Allis-Chalmers-Bullock, Limited

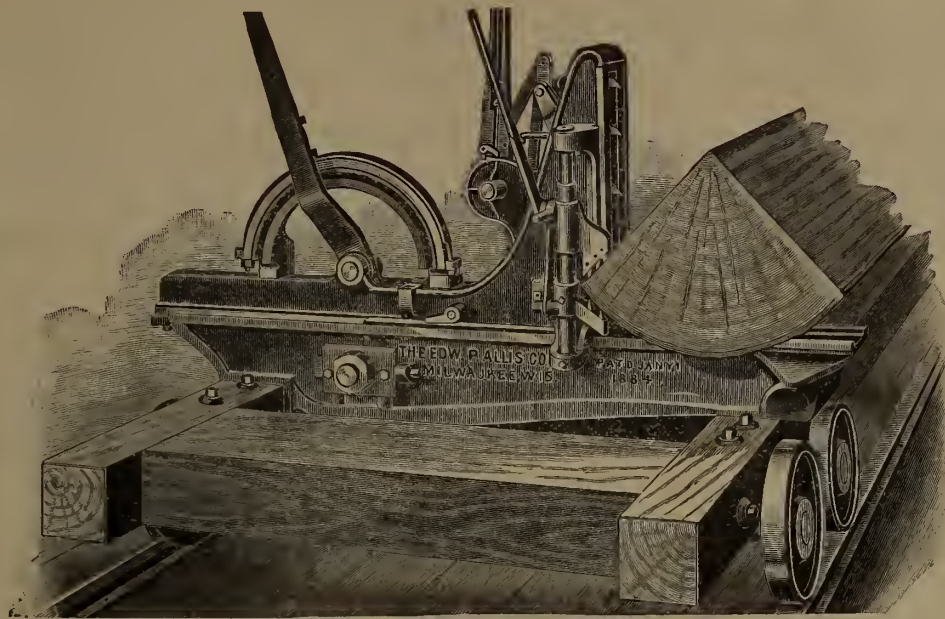

A QUARTERED LOG DOG.

A right-hand dog is shown holding the timber in position for the saw.
Send for our latest leaflets on circular saw mills, horizontal band resaw mills, six foot band mills, new Allis vertical valves for steam feeds and No. 2 heavy timber edger.

Works : Montreal. Branch Offices : Halifax, Toronto, Winnipeg, Nelson, Vancouver

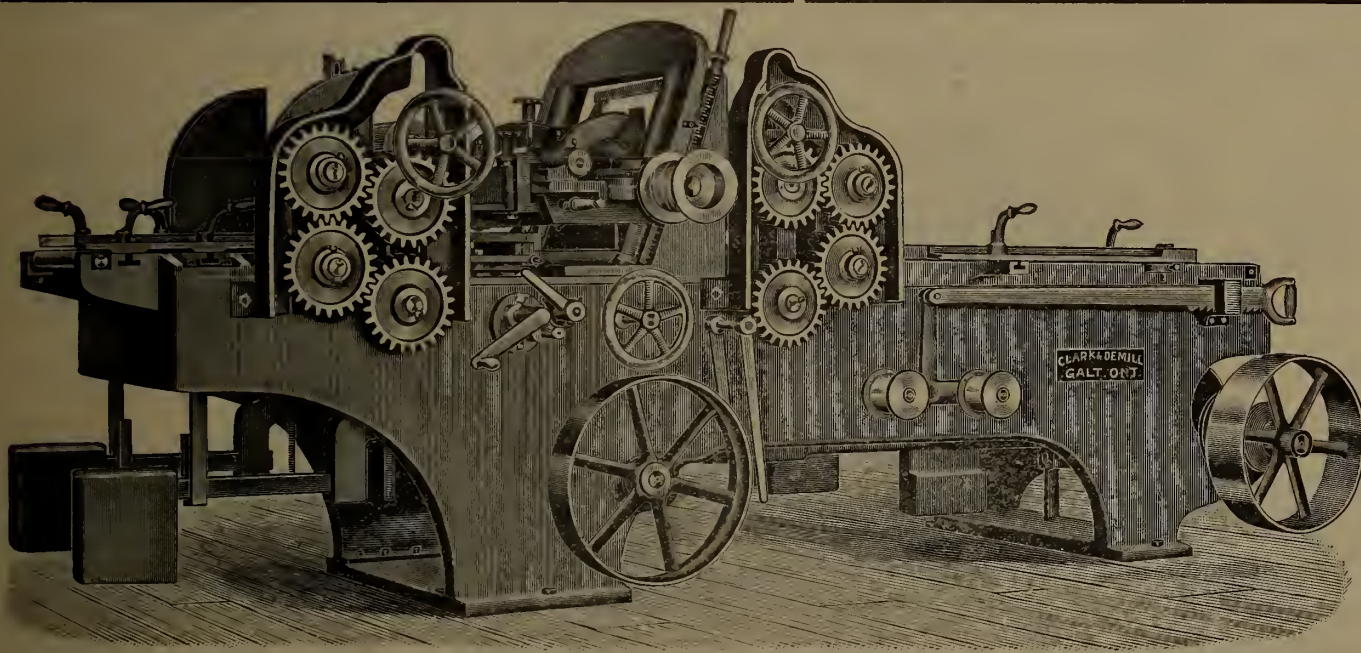

Our No. 72 LIGHTNING PLANER AND MATCHER

Kindly note that we make this machine in different sizes, single or double cylinder, as desired. Parties desiring thoroughly up-to-date machinery will find it to their advantage to write us before placing their order.

Write for new Catalogue.

Clark-Demill Co.

Limited

Hesper, Ont.

How About Wood Split Pulleys ?

When making your spring alterations in your mill you will doubtless require some Wood Split Pulleys. If you want to get the best wood split pulley manufactured to-day make your order read—

FAIRBANKS WOOD SPLIT PULLEYS

Study the cut. The web construction built in the rim not only strengthens the entire pulley but makes it impossible for the rim to work loose at the arm. Each segment is glued and nailed with three coated nails to the next one. Four point bushings are used, giving twice as much grip on the shaft as in the usual two point bushings. Write us.

THE CANADIAN FAIRBANKS COMPANY, LIMITED

MONTREAL

TORONTO

VANCOUVER

WINNIPEG



The Canadian Pacific Lumber Co., Limited

PORT MOODY, B. C.

Manufacturers and Wholesale
Dealers in All Kinds of

B. C. LUMBER, LATH, MOULDINGS, ETC.

The Largest Shed and Dry Kiln Capacity of any Mill in British Columbia.
Special Attention Given to Orders from Manitoba and the Territories.



Long Distance
Telephone Connection.



Address the Company at Port Moody or
BYRNES & CUDDY, Selling Agents, WINNIPEG

CLOVERDALE MILLING CO., CLOVERDALE, B. C.

== Red Cedar Shingles ==

OUR SPECIALTY

SECOND TO NONE

CORRESPONDENCE SOLICITED

PETER LUND, Managing Director.

J. BRECKENRIDGE, President.

MANUFACTURERS OF
ALL KINDS OF

Grows Nest Pass Lumber Co., Limited

WARDNER, B. C.



BUILDING MATERIAL

Capacity 150,000 Feet Per Day.

THE KING LUMBER MILLS, LIMITED, CRANBROOK, B. C.

Manufacturers
of

Building Materials

And All Kinds of DIMENSIONS, FLOORING, CEILING and BASE and CASE MOULDINGS

Columbia River Lumber Company, Limited

HEAD OFFICE AT GOLDEN, B. C.

Largest Capacity in Mountains

MILLS AT

- GOLDEN, B. C.
- BEAVER, B. C.
- KAULT, B. C.
- CARLIN, B. C.

ROUGH AND
DRESSED

LUMBER

FIR, SPRUCE
CEDAR AND PINE

LATH

Telephone Poles,
Piling, Etc., a
Specialty.

The Fernie Lumber Co., Limited, Fernie, B. C.

MANUFACTURERS OF AND DEALERS IN ALL KINDS OF

ROUGH AND DRESSED LUMBER

Dimension and Bridge Timber a Specialty.

Moulding in Stock or Made to Order.

JOS. GENELLE, Manager.

J. G. BILLINGS, Secretary.

THE YALE-COLUMBIA LUMBER COMPANY, LIMITED

Head Office: NAKUSP, B. C.

Mills at Nakusp, Westley and Cascade, B. C.

MANUFACTURERS OF

DEALERS IN

All Kinds Rough and Dressed Lumber,
Mouldings, Lath, Etc.

Cedar and Fir Piles, Telephone and
Telegraph Poles, Fence Posts, Etc.

NORTH STAR LUMBER COMPANY,

Head Office and Shipping Yards: ELKO, B. C.

Mills: CRANBROOK, B. C.

At present we have the following material in stock at Cranbrook, B. C.:

- 1,750,000 ft. Common Boards.
- 300,000 " Stock Boards, 8 in., 10 in. and 12 in.
- 300,000 " Shiplap, 8 in., 10 in. and 12 in.
- 100,000 " Flooring, Siding and Ceiling, 4 in. and 6 in.
- 1,550,000 " Dimensions, 8 to 24 ft.

We have a large quantity of 18 and 20 ft. lengths, from 2 x 4's to 2 x 12's.

The above is manufactured from a superior quality of pine, fir and tamarack logs. 75 per cent. of it is "bone dry."

Special sized timbers cut on short notice. Write for prices.

BRITISH COLUMBIA LUMBER AND SHINGLE MANUFACTURERS

D. & J. HADDEN, CLOVERDALE, B.C.

MANUFACTURERS AND DEALERS IN THE HIGHEST GRADE

LUMBER AND RED CEDAR SHINGLES

Send your orders to the above firm, who can supply you with shingles that cannot be beaten for quality and prices.

Agent for Ontario : Woodstock Lumber and Manufacturing Co., Woodstock, Ont.



THE PIGEON RIVER LUMBER COMPANY PORT ARTHUR, ONT.

MANUFACTURERS OF

Band Sawed White Pine Lumber, Lath, Pine and Cedar Shingles,

are operating their extensive plant night and day, to keep abreast with orders.

THERE IS A BECAUSE—

A trial order will tell you why.

Winnipeg Representative,

D. J. McDONALD, Clarendon Hotel.

J. A. SAYWARD

MANUFACTURER OF AND DEALER IN

Cedar and Spruce Lumber

Shingles, Lath, Spars, Etc.

ORDERS CAREFULLY EXECUTED
PROMPT SHIPMENTS

VICTORIA, B. C.

THE BRITISH COLUMBIA MILLS, TIMBER & TRADING COMPANY

Head Office : VANCOUVER, B. C.

Winnipeg Office : Merchants Bank Building P. O. Box 235

MANUFACTURERS OF

BRITISH COLUMBIA FIR, CEDAR and SPRUCE—both Rough and Dressed. Sash, Doors, Mouldings, Lath and the Highest Grades

"ROYAL CITY BRAND"

RED CEDAR SHINGLES

DOUGLAS FIR TIMBER

All Widths and Thicknesses up to 120 feet in Length Supplied on the Shortest Possible Notice.

OWNERS AND OPERATORS OF

HASTINGS SAW MILL - VANCOUVER, B. C.
ROYAL CITY SAW MILL, VANCOUVER, B. C.

ROYAL CITY SAW MILL, NEW WESTMINSTER, B. C.
MOODYVILLE SAW MILL - BURRARD INLET, B. C.

Total Capacity, 400,000 Feet of Sawn Lumber per Working Day of Ten Hours.

The Ladysmith Lumber Co., Limited

LADYSMITH, B. C.

Manufacturers of

LUMBER, LATH, SHINGLES,
MOULDINGS, ETC.

SPECIALTY: The best Cedar Shingles manufactured on the Coast.

FRESH WATER FIR LATH ALWAYS IN STOCK.

Capacity of Shingle Mill, 100,000 per day of 10 hours.

Correspondence Solicited

BRITISH COLUMBIA LUMBER AND SHINGLE MANUFACTURERS

Mouldings

Shingles

VICTORIA LUMBER AND MANUFACTURING CO., LIMITED

MILLS AT CHEMAINUS, B. C.

FIR AND CEDAR LUMBER

of all descriptions, in straight or mixed cars. We can supply large and long timbers, but don't care to ship anything over 40x40x140 feet long.

Prompt Shipments Good Quality and Manufacture Long Lived Timber

ADDRESS—

CHEMAINUS, B. C.

D. B. GRANT.

T. W. KERR

DELTA SAW MILL CO.

MANUFACTURERS OF

Rough & Dressed Lumber, Lath, Shingles, Fence Pickets, Doors, Sash, Mouldings, Salmon and Fruit Boxes, and Round Tanks

Correspondence Solicited. LADNER, B. C.

CEDAR LUMBER

Manufacturers and Shippers

Cedar, White Pine, Fir Lumber, Lath, Mouldings, Shingles

Bowman Lumber Co., Ltd. Revelstoke, B. C.

Mills at { REVELSTOKE, B. C. COMAPLIX, B. C.



ROSS BROS & CO.

FORMERLY OF WHITEMOUTH, MAN.

SUCCESSORS TO THE ELKMOUTH LUMBER CO. ELKMOUTH, BRITISH COLUMBIA

Full Lines Kept in

Pine, Fir and B. C. Tamarac

ORDERS RESPECTFULLY SOLICITED

Send for Our Prices

The East Kootenay Lumber Co., Limited

Saw and Planing Mills at Ryan, Cranbrook and Jaffray, B. C.

Capacity, 150,000 Feet Per Day

MANUFACTURING

LARCH

PINE and FIR

Lumber, Timber, and all kinds of Mouldings, also dealers in Railway Ties, Piles and Poles

Large Stocks of Well Seasoned Dry Material Always on Hand

Head Office: CRANBROOK, B. C.

The Cook & Bros. Lumber Co.

Of Ontario, Limited MILLS at SPRAGGE, Algoma Dist., Ont. on "Soo" Branch C.P.R.

OFFICES { Manning Arcade, Toronto Coristine Building, Montreal And at Mills at Spragge.

MANUFACTURERS OF

White and Red Pine Lumber and Lath

Water Shipments

Scribner's Lumber and Log Book

A handy book for Lumbermen. Gives Correct Measurements of Scantlings, Boards and Planks; Cubical Contents of Square and Round Timber; Doyle's Rules, and much other practical information.

ADDRESS

Price 35 Cents

THE CANADA LUMBERMAN, Toronto, Ont.

Moreau's Pupwood Barking Machine

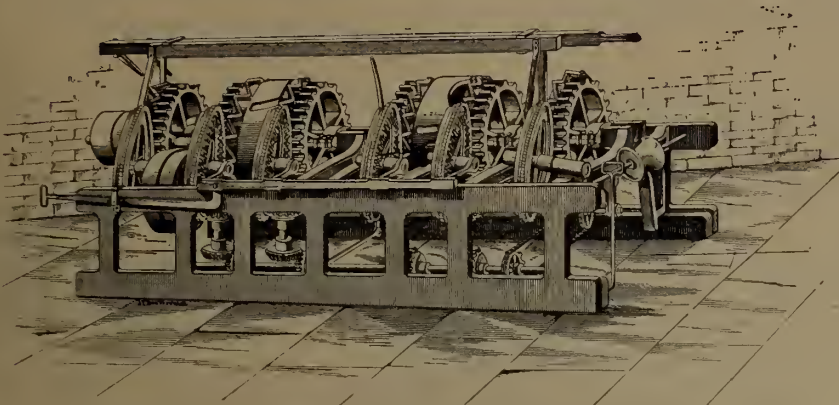

WEIGHT 4,200 LBS.

Latest and best Pulpwood Barking Machine. Requires about 7 h. p. to drive it full speed in work and one man can handle it and bark 22 to 30 cords of 4 foot wood per day according to average size of wood.

Wood is fed end on and any size from 3 to 24 inches, as the wood runs without loss of time between sticks. No long shavings and greatest economy in wood. Machines may be seen working any time. Write me for particulars.

R. S. P. SMYTH - QUEBEC, QUE.

Sole Agent for Canada

*P. O. Box 236
L. D. Phone 386*

THE E. LONG MANUFACTURING CO., ORILLIA, ONT.

THESE SAW CARRIAGES ARE MADE OF CAST STEEL, AND OPEN 36 TO 54 IN. FROM SAW.

We build Double Edgers, Steam Feeds, Log Jacks, Live Rolls, Trimmers, Slab Slashers, Steam Niggers.

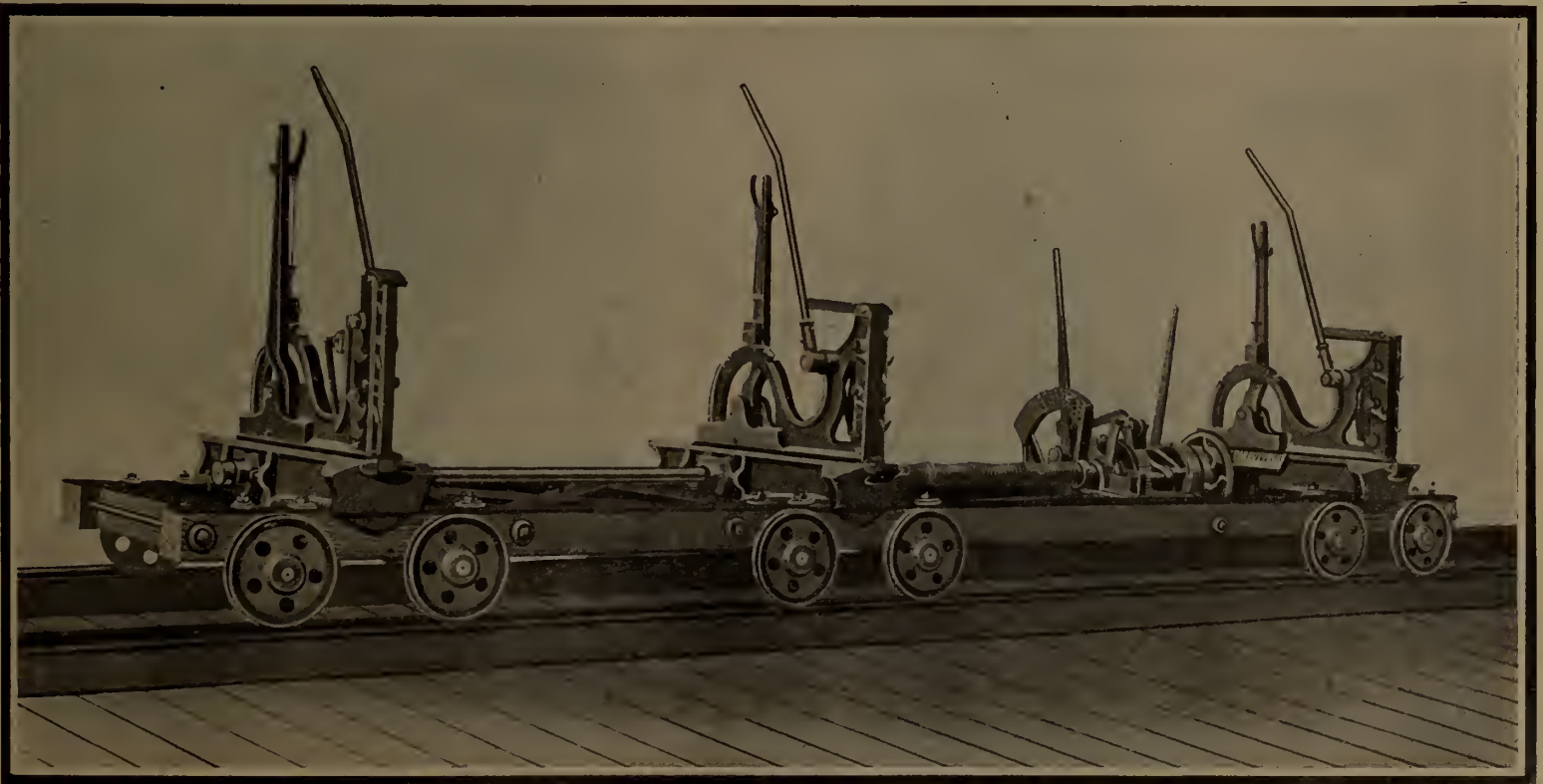

COMPLETE LINE OF SAW AND SHINGLE MILL MACHINERY
WRITE FOR CATALOGUE AND PRICES

"DEFIANCE"

Wood--Working Machinery

For Manufacturing

HUBS, SPOKES, WHEELS, WAGONS,
CARRIAGES, RIMS, SHAFTS, POLES,
NECK-YOKES, SINGLE TREES, BARREL
HOOPS.

Handles of Every Kind, Insulated Pins, Spools,
Bobbins, Oval Wood Dishes, and General Wood-
Work.

Invented and Built by

THE DEFIANCE MACHINE WORKS,
Defiance, Ohio, U. S. A.



PATENT BAND RIP SAW

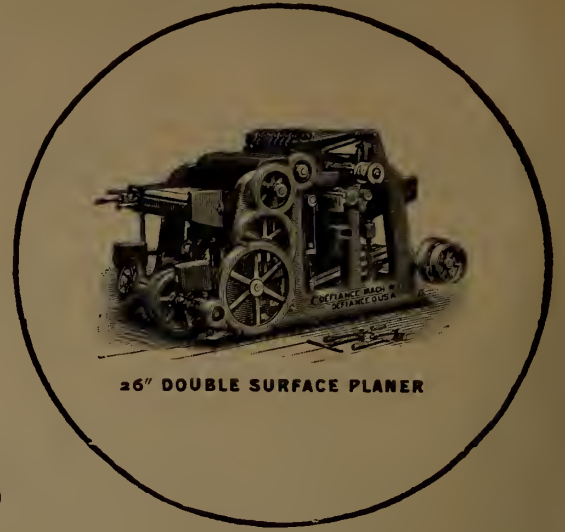

26" DOUBLE SURFACE PLANER



The "Alligator" Steam Warping Tugs

SIDE WHEELS OR TWIN SCREWS

The Twin Screws are arranged with flexible joint to
raise up in crossing portage

MANUFACTURED BY

WEST & PEACHEY, - Simcoe, Ont.

Cables carried in stock for renewals

Pure Manila
Rope

HIGHEST QUALITY MADE

British Manila

Sisal Rope

PURE SISAL

Lath Yarn

Wire, Write or Phone

Canadian Cordage
& Manufacturing
Company, Limited

Toronto, Ontario, Canada

Long Distance Phone 162.

Our Rope and Lath Yarn are Recogniz-
ed as the Best on the Market.



RODGERS IRON MFG. CO.
MUSKEGON, MICH.

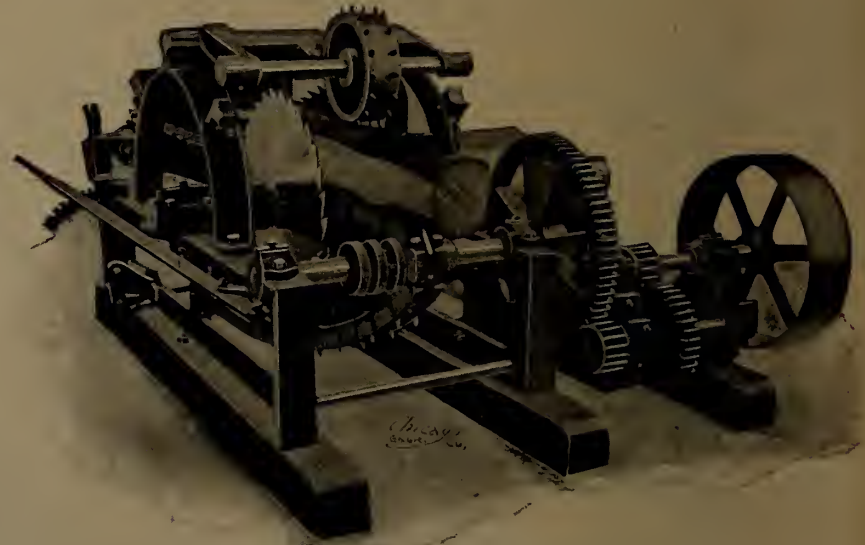

ADJUSTABLE LOG SIDER OR TIE MACHINE.

A Money Maker

Write to Us

We will Tell You All About It



Cedar River, Mich., Oct. 1, 1904.

Rodgers Iron Mfg. Co.,
Muskegon, Mich.

Gentlemen:—Regarding the tie machine which we purchased from you. It is running every day and doing good work, but the tie timber does not come down fast enough to keep it running steady as they come down the river with the saw logs. We have sawed 700 ties in ten hours and if it was kept in timber steady, could easily saw over 1,000.

Yours truly,



Messrs. Rodgers Iron Mfg Co.,
Muskegon, Mich.

Croghan, N. Y., Feb. 25, 1905.

Gentlemen:—Replying to yours of the 21st inst. regarding adjustable log sider or tie machine sold me something over a year ago. I am using this machine as an auxiliary saw in my mill, siding all my large logs on the circular for the gang, and running the smaller logs through the log sider. This has enabled me to increase the cut of my mill 20M a day. These I run through the gang with the larger cuts without extra cost.

I am more than pleased with the work of the machine, and you may refer to me as often as you please.

Yours,

*** THE ***
**MAPLE LEAF
 SAW WORKS**



**Shurly &
 Dietrich**
 GALT, ONT.

Manufacturers of

**CIRCULAR SAWS
 GANG SAWS
 MILL SAWS
 BAND SAWS
 CROSS-CUT SAWS**

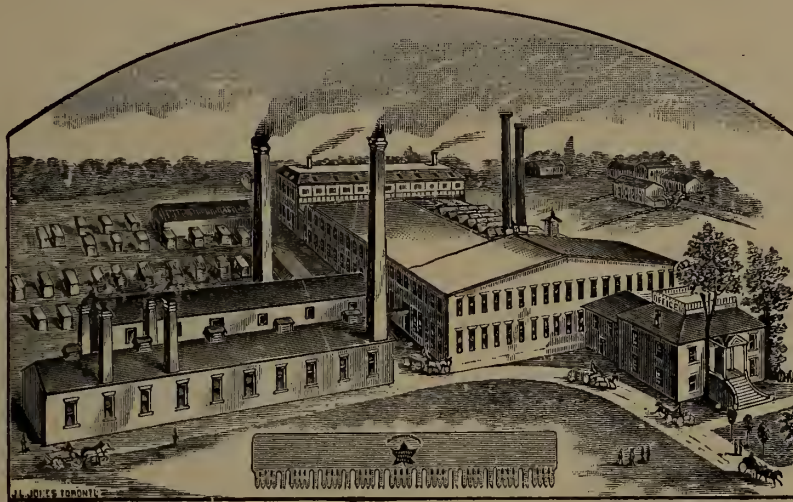

Manufacturers of

**HAND SAWS
 BUCK SAWS
 PLASTERING TROWELS
 BUTCHER SAWS
 STRAW KNIVES, &c.**



Maple Leaf Saw Set

MANUFACTURED BY

SHURLY & DIETRICH, Galt, Ont.



Directions.—Place the set on the point of tooth, as shown in the accompanying cut, and strike a very light blow with a tack hammer. If you require more set, file the tooth with more bevel.

If you follow directions you cannot make a mistake. Be sure and not strike too hard a blow, and it will set the hardest saw. On receipt of 40 cents we will send one by mail.

We are the only manufacturers in the world who export Saws in large quantities to the United States.



GROUND THIN ON BACK

Save Labor Save Gumming
 Save Time Save Files

This Saw Stands Without a Rival

AND IS THE

FASTEST CUTTING SAW IN THE WORLD!

Its Superiority consists in its Excellent Temper. It is made of "Razor Steel," which is the finest ever used in the manufacture of Saws. We have the sole control of this steel. It is tempered by our secret process, which process gives a keener cutting edge and a toughness to the steel which no other process can approach.

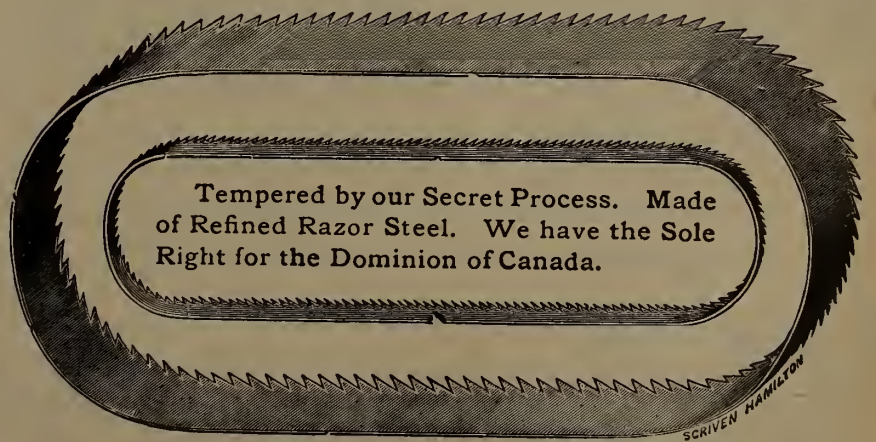

We Manufacture

HIGH GRADE BAND SAWS

Of All Widths and Lengths.

These Saws are made of Refined Swedish Steel imported direct, and tempered by our Secret Process; for Fine Finish and Temper are not excelled.

CLASSIFIED INDEX OF ADVERTISERS

AXES
Dundas Axe Works. 39

ALLIGATOR TUGS
West & Peachey. 8

BELTING
Canadian Fairbanks Co. 3
Dominion Belting Co. 38
Gutta Percha & Rubber Mfg. Co. 41
Goodhue & Co., J. L. 1
McLaren, D. K. 1
McLaren Belting Co., J. C. 44
Waterous Engine Works Co. 38
Wilby, P. H. 12
Young, J. S. 1

BABBITT METALS
Syracuse Smelting Works. 44

BOILERS
Dymet Foundry Co. 36
John McDougall Caledonian Iron Works 32

DOORS
New Century Refrigerator & Mfg. Co. 10

DRY KILNS
Andrews Co., The A. H. 43
McEachren Heating & Ventilating Co. 43
Sheldon & Sheldon. 43
Standard Dry Kiln Co. 43

ELEVATING AND TRANSMITTING MACHINERY
Perrin & Co., R. 12

EMERY WHEELS
Hart Corundum Wheel Co., Limited. . 28

ENGINES AND LOCOMOTIVES
Dymet Foundry Co. 36
Gartshore, John J. 10
Owen Sound Iron Works. 41
Robb Engineering Co. 35

EDGERS
DeLoach Mill Mfg. Co. 11
Gordon Hollow Blast Grate Co. 35

GRATES
Gordon Hollow Blast Grate Co. 35

LUMBERMEN'S SUPPLIES
Beal Leather Co., R. M. 30
Barr, Alex. 12
Capstan Mfg. Co. 22
Johnson, A. H. 35
Park, Blackwell Co. 39
Rice Lewis & Sons, Limited. 44
Thompson Mfg. Co. 30
Tobin, Joshua. 28
Woods, Limited. 1

LUMBER AND SHINGLE MANUFACTURERS
B. C. Mills, Timber & Trading Co. . . 5
Bowman Lumber Co. 6
Cook & Bro. Lumber Co. 6
Canadian Pacific Lumber Co. 4
Cloverdale Milling Co. 4
Crows Nest Pass Lumber Co. 4
Columbia River Lumber Co. 4
Delta Saw Mill Co. 6
East Kootenay Lumber Co. 6
Ferne Lumber Co. 4
Hadden, D. & J. 5
King Lumber Mills. 4
Ladysmith Lumber Co. 5
North Star Lumber Co. 4
Pigeon River Lumber Co. 5
Ross Bros. & Co. 6
Sayward, J. A. 5
Victoria Lumber & Mfg. Co. 6
Yale-Columbia Lumber Co. 4

LUMBERMEN'S TOOLS
Baldwin, Tuthill & Bolton. 41
Burton Saw Co., A. J. 39
Hay Knife Co., Peter. 38
Pink, Thomas 44

LUMBERMEN'S AGENTS
Friel, H. J. 38
Wright, H. J. 38

MISCELLANEOUS
Alexander Engraving Co. 30
Bradstreets. 10
Canadian Office & School Furniture Co. 10
Denton, Dunn & Boulbee, Barristers. 38
Fielding, J. S., Consulting Engineer. . 1
Glenyards Fire Clay Co. 37
Georgian Bay Engineering Works—
Grinders. 43
Huther Bros.—Dado Heads. 44
Lumber Mutual Fire Insurance Co. . . 33

Midland Engine Works Co.—Tram
Car Wheels. 12
Mitskun Co., M.—Car Movers. 30
Monteith, Nixon & Ch.—Trucks. 30
Manitoba Gypsum Co.—Plaster. 38
Spence & Co., R.—Files and Risps. . 11
Sessenwein Bros.—Rails. 29
Toledo Fire Insurance Co. 31
Vogel, C. H.—Pulp Mill Engineer. . . 32

OILS.
Commercial Oil Co. 38
Canadian Oil Co. 22
Queen City Oil Co. 11

PROVISIONS
Eckardt & Co., H.P. 27

PORTABLE SAW MILLS
Drake, F. J. 36
Owen Sound Iron Works. 41

PLANERS AND MATCHERS
Clark & Demill 3

PULLEYS
Canadian Fairbanks Co. 3

PACKING AND PIPE COVERING
Garlock Packing Co. 12
Purvis Co., E. L. 37

ROPE
Canadian Cordage Co. 8
Consumers Cordage Co. 33
Dominion Wire Rope Co. 12
Greening Wire Co., B. 1
Mussen & Co., W. H. C. 1

ROOFING
Bird & Son, F. W. 30

RE-SAWS
Cowan & Co. 37

SAW SWAGES
Hanchett Swage Works. 29

SAW GAUCES
Specialty Mfg. Co. 12

STEAM BOILERS
Canada Foundry Co. 12
Owen Sound Iron Works. 41

SAWS
Atkins & Co., E. C. 37
Burton Saw Co., A. J. 39
Burns Saw Co., E. R. 1
Hoe & Co., R. 40
Shurley & Dietrich 9

SAW MILL MACHINERY
Allis-Chalmers-Bullock 3
Furniture City Tool Co. 37
Gordon Hollow Blast Grate Co. 35
Hamilton Mfg. Co., Wm. 2
Jenckes Machine Co. 32
Kendall, I. N. 41
Long Mfg. Co. 7
Lloyd Mfg. Co. 38
Manitoba Iron Works. 33
Mowry & Sons, B. R. 40
Owen Sound Iron Works. 41
Petrie, H. W. 1
Payette & Co., P. 33
Schaake Machine Works. 8
Smart-Turner Machine Co. 44
Waterous Engine Works Co. 42
Williams, Madison. 11

SHINGLE MILL MACHINERY
Drake, F. J. 36
Long Mfg. Co., E. 7
Owen Sound Iron Works Co. 41
Schaake Machine Works. 8
Williams, Madison. 11

STOVES
Hall, Adam. 40

TURBINES
Williams, Madison. 11

TRIMMERS
DeLoach Mill Mfg. Co. 11
Gordon Hollow Blast Grate Co. 35

WOODWORKING MACHINERY
American Woodworking Machinery
Co. 34
Clark & Demill. 3
Connell & Dengler Machine Co. 35
Cowan & Co., Limited. 37
Dodge Manufacturing Co. 10
Defiance Machine Works. 8
Perkins & Co. 39
Rogers Iron Mfg. Co. 8
Sherman Co., W. S. 35
Shimer & Sons, Samuel J. 39
Waterous Engine Works Co. 42

The . . .
QUEEN CITY OIL CO.
LIMITED
Head Office: TORONTO.

HIGHEST GRADES OF
Refined Oils
Lubrication Oils
AND ALL
Petroleum
Products



ESTABLISHED 1849.
BRADSTREET'S
Capital and Surplus, \$1,500,000.
Offices Throughout the Civilized World.
Executive Offices:
Nos. 346 and 348 Broadway, NEW YORK CITY, U.S.A.
THE BRADSTREET COMPANY gathers information that reflects the financial condition and the controlling circumstances of every seeker of mercantile credit. Its business may be defined as of the merchants, y the merchants, for the merchants. In procuring, verifying and promulgating information, no effort is spared, and no reasonable expense considered too great, but the results may justify its claim as an authority or all matters affecting commercial affairs and mercantile credit. Its offices and connections have been steadily extended, and it furnishes information concerning mercantile persons throughout the civilized world.
Subscriptions are based on the service furnished, and are available only by reputable wholesale, jobbing and manufacturing concerns, and by responsible and worthy financial, judiciary and business corporations. Specific terms may be obtained by addressing the company or any of its offices. Correspondence invited.
THE BRADSTREET COMPANY.
OFFICES IN CANADA: Halifax N.S. Hamilton, Ont. London Ont.; Montreal, Que.; Ottawa, Ont.; Quebec, Que.; St. John, N. B. Toronto, Ont. Vancouver, B.C.; Winnipeg, Man.
THOS. C. IRVING,
Gen. Man. Western Canada, Toronto

RAILS For Logging Tramways, Switches, Etc.
YARD LOCOMOTIVES New and Second-Hand.
John J. Gartshore
83 Front St. West,
(Opposite Queen's Hotel,) Toronto.

R. SPENCE & CO.
Beech File Works.
HAMILTON, ONT.
FILE AND RASP MANUFACTURERS
AND RE-CUTTERS
A trial order solicited. Write for price list and terms.
C. P. MOORE, PROPRIETOR.

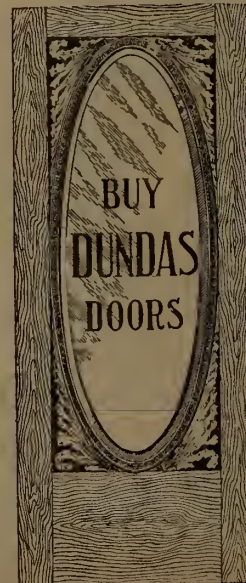

New Century Refrigerator & Manufacturing Co., Limited
Dundas, Ont., Can.

Our Business is Manufacturing
HARDWOOD VENEER . . DOORS
With Built Up Bodies

These Doors are guaranteed not to warp or twist and are superior in construction and finish to any other Door on the market.
Send for Illustrated Catalogue and Prices.
Special attention given to Architects' Designs of Doors and Trims.

AGENTS WANTED EVERYWHERE.

ADDRESS DOOR DEPARTMENT

DeLoach New Trimmers and Gang Edgers

WITH VARIABLE FRICTION FEED

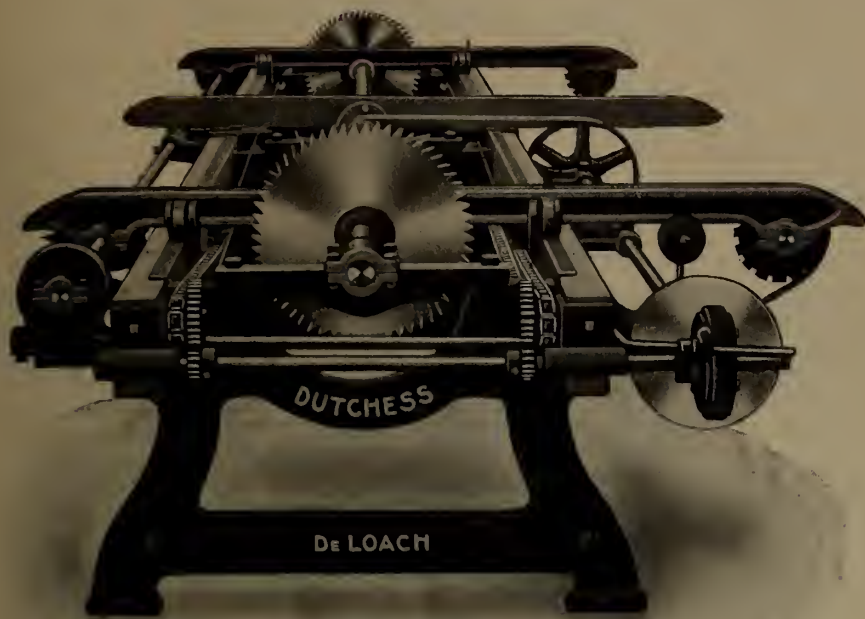

Trimmer has power attachment for operating head blocks and Edgers have power attachment for raising top rolls and three rolls corrugated and driven.

Write for 144 page catalogue illustrating and describing our 1905 models of Saw Mills, Edgers, Trimmers, Planers, Shingle Mills and Lath Mills all with up-to-date variable friction feed, also Stave Mills, Corn Mills, Water Wheels and Hay Presses.

Our "Monarch" Saw Mill with One Mandrel and One Saw does the work of a double mill.

DeLoach Mill Manufacturing Company, Box 509, Atlanta, Ga.

THE TRIUMPH TURBINE



Is the most powerful wheel on the market to-day. A glance at this cut of the centre shows that the buckets are designed to secure the **maximum of speed** with **great power** and a **free discharge**. Mr. E. S. Edmondson, of Oshawa, writes as follows under date of November 16th, 1903, regarding a 26 inch Vertical Triumph Wheel:

"The Wheel is strictly first-class in every particular, and after a careful and thorough test I am prepared to say that I believe it is the best wheel in the market for Electrical purposes. It has high speed, large power, high efficiency at part gate, and has practically no leakage. I am more than pleased with the thorough and workmanlike setting you gave me throughout."

For horizontal settings in large Pulp Mills, Cement Mills or Electric Power Developments this Wheel has no equal. We invite your enquiries. Large catalogue to be had for the asking.

We are always glad to submit estimates and prices on **Improved Vulcan and Leffel Turbines, Improved Lane Circular Saw Mills, Edgers, Trimmers, Slashers, Shingle Machines, Lath Machines** and all machinery of this kind.

MADISON WILLIAMS

H. E. PLANT, Agent
Cor. Common and Nazareth Streets
Montreal, Que.

Successor to Paxton, Tate & Company
PORT PERRY, ONT.

Manitoba Iron Works
Western Selling Agents
Winnipeg, Man.

TRAGIC DEATH OF SAMUEL BINGHAM.

General sorrow prevails in the Capital and throughout the Ottawa Valley as the result of the tragic death of Mr. Samuel Bingham, ex-mayor of Ottawa, who was drowned in the Gatineau river, two miles south of Wakefield, on June 17th. Mr. Bingham was an extensive contractor for driving logs down the Gatineau river. Friday evening about 11 o'clock he was advised that a great jam of logs had formed above the Cascade, and shortly after midnight he started to drive to that point. With the assistance of his crew he succeeded in breaking the jam about 8 a. m. the next morning, and

went to the woods for a while. Afterwards he began work as a saw filer and later on entered upon the business of his life and in doing which he lost his life. It was, as has been stated, that of collecting logs on the Gatineau river and floating down to Ottawa the timber product of the Gatineau country. For years he had the contract for this work, which, although involving many difficulties, was performed with entire satisfaction. Over all the operations, extending from the forks of the Gatineau to its outlet, Mr. Bingham was the personal supervisor, never relegating the responsibility to others. If a boom broke or any-

orphanages or hospitals. His success in life in a material way was due largely to his indomitable energy. In religion he was a Catholic—a pillar of St. Bridget's church.

THE BOX ESTIMATOR.

Among the more valuable compilations to assist the lumberman, box manufacturer and wood-worker is "The Box Estimator," published by James M. Leaver, of Sault Ste. Marie, Mich. This work gives in feet, board measure, the amount of lumber required to make a box of practically any dimensions. The sizes are adjusted to the quarter inch—



BRITISH COLUMBIA MILLS, TIMBER AND TRADING COMPANY'S ROYAL CITY PLANING MILLS, NEW WESTMINSTER.

1. Patent door-making machine. 2. Interior of box factory. 3. Interior of shingle mill. 4. Interior of sash and door warehouse. 5. Shingle mill drag-saw. 6. Box-making sheds. 7. Glazing room. 8. Interior of sash and door factory.

although tired out through loss of sleep, he started to return to Ottawa in the forenoon. His horse and rig were found in the water near Wakefield, some thirty miles from Ottawa, but Mr. Bingham was missing. It is believed that while he was asleep his horse walked into the water and that he was thus drowned.

Deceased was born in Ottawa in 1841, and starting as a poor boy attained considerable wealth. Early in life he went to work in a mill at Ramsey village, now known as Almonte. The noise and dust not agreeing with him, he

thing went wrong he was summoned to the scene. He knew the Gatineau river, its every crook and curve, its rapids and bays, most thoroughly.

The public career of Mr. Bingham began in 1880, when he was elected to the Council as a representative of Ottawa Ward. He was elected to the position of mayor in 1897 and re-elected by acclamation in 1898. He never accepted any salary as mayor. Each month when the pay cheque came to hand he endorsed it over to some deserving charity such as the

that is, between each even inches are three sizes embracing the intervening 1/4, 1/2 and 3/4. To give an idea of the range covered by this complete work the first size given is 1 x 1, the last size 100 x 100 3/4. Each intervening size in quarter inches is covered. It is also most useful in the manufacture of doors, sash, blinds, veneers, carriage work, etc.

Judging by the number of testimonials the author has received the work is meeting with merited success. From a large number the following are given :

G. & J. Esplin, Montreal, Quebec : " We are thoroughly pleased with your book in every particular."

Port Huron Box Co., Port Huron, Mich.: " The book is well worth the money."

The Rathbun Co., Deseronto, Ont.: " Would rather separate ourselves from the ten dollars than the book. It is certainly a time saver."

National Box Co., Chicago, Ills.: " We have had all that we have heard of, and find yours the only practical one in all cases."

Eagle Box & Mfg. Co., Oakland, Cal.: " Box manufacturers who have been fortunate enough to procure one of your estimators ought to exclaim "Eureka." The writer has been in the box business for over a quarter of a century, and it is the best he has ever had the pleasure of examining."

W. T. Valentine & Son, Albany, N.Y.: " After using your work can not go back to the old method of figuring."

The book will be sent on trial if desired. The price is ten dollars.

SOME ADVICE ON SAW OPERATION.

A correspondent of the Timber News, London, Eng., signing himself "Sussex", writes as follows:—"I have noticed that the saw in my horizontal frame seems to bind in the wood, the log trembling as if the saw does not free itself. I have examined the blade and find that it is perfectly straight, and yet it seems to cut more on one side than the other. The feed is continuous, so the saw is divided into two sections of teeth, which cut as they return to the end of the frame. Is this right? Can the jarring on the log be prevented?"

We reproduce the answer given:—"Sussex" does not say what feed they use, nor what sized timber they saw. Still there is sufficient detail to form an accurate opinion why his saw makes the log move while it is being cut. Consider the conditions. The saw is perfectly straight, and the feed continuous. The teeth are pointed to each end of the saw, the division between the two sections of the teeth being in the centre of the saw. The log is always advancing, no allowance being made, owing to the saw being straight, for the periods when the reciprocating parts are at rest, or, what is of more importance, when the back of the teeth is being passed through the wood.

Watch the stroke of the saw. The teeth are close against the wood and they clear a path until the half of the saw has passed, then the back of the teeth are dragged through, and the log is still advancing. Without teeth points, the saw does not make a kerf, so the log is pressed hard against them, and then can we wonder that such causes produce objectionable effects? The log moves under the strain, the saw is jammed, and there is a continual jarring on all the parts. As soon as the saw is right back, the teeth which have been rubbing against the wood have a chance to clear themselves, and they do with violence, for is not the wood pressing hard against them? A little consideration about what is needed under the circumstances would soon rectify matters. The saws must be put so that they will only cut with the

teeth points, and when the back of the teeth is being pressed through the wood, sufficient kerf should have been taken out by the preceding cut to allow them to pass without any friction.

Something similar has to be done with the vertical deal frame saws. The top part has to be thrown forward, so that the cut taken allows the teeth to be drawn back as they rise while the wood advances, otherwise the pressure on the deal would lift it out of the roller and fence. So it must be with the horizontal frame saws. I presume that "Sussex" has been cutting soft English timber, and has accelerated the feed. If that was very slow, the conditions he states would hardly be noticed, but forcing the feed throws a greater strain upon the saw. He must find out what is the greatest advance taken by the travelling table in proportion to the horizontal saw frame, and then regulate his saw to that, so that it will be free when not cutting.

To do this, the blade must not be kept straight, but greater in width in the centre, tapering to the ends. Allow just a little more than the advance of the table during half the stroke of the saw blade, so that when it is at work the conditions will be like this. Say the saw is at the end of the stroke and about to return. The teeth at the other end will cut their way through the wood, clear a kerf, then the remaining teeth which are pointed the other way will pass through the clearance without touching the wood, although the log is still advancing, owing to the preceding teeth being in advance in the centre of those at the end, and those that are pointed the other way will recede, owing to the same effect, so that when they move the reverse way, and the points are at work, they clear a kerf for the other half of the saw to move in without jarring the wood. So if "Sussex" will arrange to alter his saws that instead of being straight they are wider in the centre than the ends, in proportion to the feed of the machine, he will find that considerably less power will be taken by his horizontal saw frame, and better results obtained from the saws.

THE WESTERN CANADA PULP AND PAPER COMPANY.

According to recent advices, the Western Canada Pulp and Paper Company has been floated in London, England, and has absorbed the Pacific Coast Pulp & Paper Company and the Industrial Pulp & Paper Company, of British Columbia. It is capitalized at \$2,500,000. The board of directors is composed mainly of heads of paper manufacturing concerns in London, as follows : W. C. Ward, Chairman of the London Committee of the Canadian Bank of Commerce, Chairman ; Lewis Evans, director of John Dickinson & Co., paper manufacturers ; T. Y. Nuttall, director of Cooke & Nuttall, paper manufacturers ; R. A. Workman, of Montgomerie & Workman ; and E. C. Leachman, director of Spicer Bros., Ltd., paper manufacturers and wholesale stationers.

The Canadians interested in the companies which have been absorbed are J. J. Shallcross, H. B. Thomson, Percy Criddle, Victoria ; W.

W. Beer, Nelson ; G. F. Beer, Toronto, and P. G. Shallcross, Dr. R. E. McKechnie, and Geo. Cowan, Vancouver.

This company has 163,000 acres of pulp wood limits, and will establish a plant at Powell river, situated on the mainland just north of Texada island in British Columbia.

It is the intention of the company to erect pulp and paper mills just above the falls on the river. There is at least 20,000 h.p. available, and the location is but 600 yards from high water mark. The harbor is also excellent. There will be an ultimate expenditure of \$750,000, and the plant is expected to start with a capacity of about 100 tons daily.

Considerable preliminary work has been done. All surveys of the limits have been made, a topographical survey of the mill site has been completed, and a contour survey carried out. Drawings of the proposed buildings, specifications and estimates are already prepared. It is reported that as soon as operations commence in construction, between 500 and 1,000 men will be employed.

The establishment of pulp industries means a more complete utilization of the timber resources of British Columbia. Spicer Bros., of London, Eng., agreed to act as agents of the company for the sale of paper and pulp for a period of ten years. The company have reserved, however, to themselves the selling of their products in the markets of the North American Pacific coast down to and including California. The company has also entered into a contract with Edward Lloyd, Ltd., of London, for the sale for five years of 10,400 tons per annum of "news" paper at satisfactory prices. Messrs. Lloyd have the option to renew the contract for a further period of three or five years.

It is expected that the mills can be completed in eighteen months after work begins, and the estimated output per year will be 18,000 tons of "news" paper and 7,500 tons of sulphite pulp.

SYMBOLS FOR HARDWOOD LUMBER GRADES.

At a recent meeting of the Hardwood Manufacturers' Association of the United States a very important step forward was taken with respect to inspiring the confidence of consumers in the grades of lumber put upon the

PANEL AND WIDE NO. 1.	○
WIDE NO. 2.	△
BOX BOARDS	B
FAS OR FIRSTS & SECONDS	⊙
SAPS	S
SELECTS	△
NO. 1. COMMON.	①
NO. 2. COMMON.	②
NO. 3. COMMON.	③
NO. 4. COMMON.	④

market by the members of that association. This was done by the adoption of distinctive symbols or marks, one for each of the ten grades into which hardwood lumber is now classified under the rules of that association. The symbols adopted are shown herewith.

three to eight hour, depending upon its thickness. The water is then drawn out of the tank, the outer door opened and the load rolled on to roller rack wagon for transportation to the yard. The company advise us that the process completely removes all sap and pitch from the lumber and that stock thus treated will dry in the air in about one-half the usual time and can be thoroughly dried in an ordinary kiln in five days. The device is inexpensive and of their own design and the cost of preparing the lumber for the steamer about equal to loading it on to a dry kiln car.

On this subject an exchange says: "Care in piling will do a great deal. By using narrow

or too little, has a harmful effect rather than otherwise. Out in Washington a number of years ago, a manufacturer tried the use of smoke in his dry kiln, instead of steam or hot air and claimed that the lumber took on a brightness that the steam kilns did not impart. He also found that the lumber was lighter than even air-dried stock. This might work in localities where the bulk of the lumber is kiln-dried, but none of these processes are practical for general use."

LOGGING OPERATIONS BY COMPRESSED AIR AND STEAM.

The felling of timber and cutting it into logs by compressed air, then skidding the logs to

The first detail of the system, to begin with the first step in logging operations, is the mechanism, driven by compressed air, which saws down the trees and then cuts them up into logs. This consists of a cross cutting saw, adjusted to an arm, which is fitted with a system of cylinders and pistons, acted upon by compressed air. The saw is brought to the tree or the log, by what is known as the shotgun feed action in sawmills, only in this instance the saw is brought to the log instead of the log to the saw. The entire mechanism is mounted upon a truck or sleigh, of the ordinary size. This is hauled to the tree. The saw is then speedily adjusted to any angle de-



BRITISH COLUMBIA MILLS, TIMBER AND TRADING COMPANY'S ROYAL CITY PLANING MILLS, VANCOUVER.

1. Office. 2. Ready-made house-erecting shed. 3. Steamer Belle towing boom of logs to mill. 4. The effect of water-sprinkler system, when turned on lumber in dry kiln, to prevent the spreading of fire. 5. Delivery end of dry kilns. 6. Shipment of 200,000 feet of specially-selected spruce oak stock for the British Admiralty. 7. Loading end of dry kilns. 8. Floating drag-saw in standing boom. 9. Car-loading scene. 10. Booms of logs attached to standing boom. 11. Dry kiln lumber shed

strips between courses, piling the lumber so that the ends will not touch, and leaving a vacant space, or chimney up through the middle of the pile much can be accomplished to produce the desired results. A favorite process over in Michigan has been the sprinkling of the green lumber with salt. Many of the sawmill plants there have been operated in connection with salt blocks and the salt was easily obtained. The process consisted of sprinkling each course with a thin layer of salt, and the effect is said to have been good, though too much salt,

the road hauling them to the rollway, by steam power is the gift of H. B. Frey, of Minneapolis, to the lumbering industry. This new invention is a complete system for logging, which, to a great extent, eliminates horses and the labor of men from lumbering operations in the woods. It is adaptable to any country, to any topography, the mountain, the valley, the plain and the steep hillside. It will operate under all conditions of climate, and in all kinds of weather. It matters not whether snow is on the ground, or the ground covered with summer's carpet.

sired to attack the tree, and after it is felled, the saw is moved alongside and the tree is quickly sawed into logs. There are movements and combinations of positions which permit the saw to adjust itself to a large tree standing on a side hill, on the level ground, or down in a declivity. These changes of position are made without the least hindrance, and can be secured almost instantaneously. The compressed air tanks are supplied by a gasoline engine, and these are mounted, together with the saw upon the same vehicle.

The log hauling and skidding device is a combination of a steel cable and pulleys, driven by steam. For hauling logs a steam upright engine is set upon a sleigh. The drive wheel is also mounted upon this sleigh, and is directly attached to the engine. A steel cable is made fast at each end of the logging road, along which the haul is made. This cable lies along the middle of the road, passes up under the sleigh and is coiled four times around the drive wheel. When this wheel is set in motion by the engine, the slack in the cable ahead of the

power. It requires eight horse-power to move the machine, all fueled and watered to run, thus leaving twenty-seven horse-power for the load. For skidding, the engine is made stationary, and the cable is converted into a live cable by passing it about a system of upright rollers, stationed at the angles. This cable is carried about in the woods where the logs have been cut. By means of a clamp, the short chain, which is attached to the log, is fastened to this live cable and dragged to the skidway.

DISPUTE AS TO CARRYING CHARGES.

A year-old controversy between the Rat Portage Lumber Company, of Kenora, Ont., and the Canadian Northern Railway Company is about to be settled. The act on is over alleged defective service supplied by the railway in connection with the company's new mill at Norwood. The lumber company complains that the railway company charges a higher freight rate than the law allows and refuses to carry sufficient logs to keep the mill in operation. It is now to be made a



BRITISH COLUMBIA MILLS, TIMBER AND TRADING COMPANY'S ROYAL CITY PLANING MILLS, NEW WESTMINSTER.
 1. Office building. 2. Shipping sheds. 3. Portion of railway lumber yards. 4. Machine shop. 5. Glass warehouse. 6. Dry kilns. 7. Moulding and dressed lumber sheds.

sleigh is immediately taken up, and the sleigh pulls itself forward. The same thing takes place to the rear when the engine is reversed, and the sleigh then moves backward. The sleighs bearing the logs to be hauled, are coupled to the locomotive sleigh, in the same manner as a train of cars, and the entire train moves easily along the road to its destination. About the curves the cable is kept in its place in the middle of the road by a system of trips, which drop down and permit the sleigh to move over them. The engine is of thirty-five horse

In the different details of the invention Mr. Frey has brought out a remarkable series of original ideas, all of which harmonize to produce a complete and practicable system for speedy handling of logs from the timber to the end of the logging road. This new invention will be manufactured by the H. B. Frey Company, recently organized in Minneapolis. The concern is capitalized at one million dollars, and the incorporators are H. B. Frey, John F. Nichols and Ervin B. Frissell, all of Minneapolis. —Mississippi Valley Lumberman.

subject for investigation for the Railway Commission. Immediate action is requested by the lumber company.

The Rat Portage Lumber Company's limits in Ontario and Minnesota are situated along the line of the Canadian Northern Railway and necessitate the use of twenty cars daily.

T. J. Scanlan has announced that it is the intention to open the Meadows shingle mill at Nelson, B. C., this summer.

The Miniota Lumber & Milling Company, Miniota, Man., have sold their lumber business at Miniota and Arrow River to the Imperial Elevator Company.

TEON BELTING



STEAM PFOOF
 WATER " "
 HEAT " "
 OIL " "
 ACID " "
 Stronger and Cheaper than
 Leather.

LEATHER BELTING CAMELS HAIR BELTING
 CAPATA BELTING [BALATA TYPE] LACE LEATHER, ETC.

Special Arrangements for Trial Belts.
 Write for Price Lists and Discounts.

P. H. WILBY, 27½ Front Street East, TORONTO
 Phone Main 1930. SOLE AGENT FOR CANADA.

Our special
Tram Car Wheels



made from a special mixture of Iron, are stronger, longer lived, low in price and lighter for their strength than any other wheel. Write for prices and samples of metal.

MIDLAND ENGINE WORKS CO.
 MIDLAND, ONT.

LARGE STOCK CARRIED & CUT TO ANY LENGTH
 BLOCKS, CLIPS, TURNBUCKLES, ETC.

WIRE ROPE

SPECIAL ROPES FOR LUMBERING
 DOMINION WIRE ROPE Co., LTD
 MONTREAL, QUE.

EVERY LUMBERMAN WANTS IT ——— 35 cents buys it
Scribner's Lumber and Log Book

BRIMFUL OF EVERY-DAY PRACTICAL INFORMATION Address: THE CANADA LUMBERMAN, Toronto

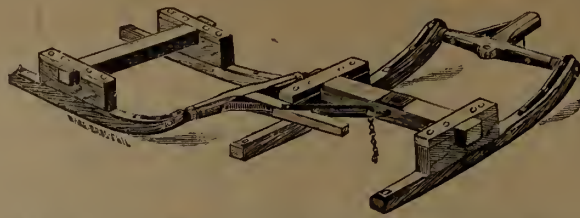

THE LUMBERMEN'S FRIEND

(Desjardin's Patent)

ALSO
 Heavy Runners for Logging Sleighs Bent to Order. Poles, Beams, Rollers, Blocks, and other parts on hand at all times.

I ALSO MAKE
 Boom Chains
 Logging Chains
 Skidding Tongs
 Clevis' Heavy
 Neckyokes and
 Whiffletrees

Large
DUMPING WAGONS
 for Mill Yards a
 Specialty

ALEX. BARR

WRITE FOR PRICES Manufacturer Pembroke, Ont.

Detachable Chain Belt

—AND—

CONVEYING

MACHINERY



William R. Perrin & Company
 Limited

TORONTO, CANADA.

WOODWORKERS SAY
 "The convenience to the Sawyer and the saving in lumber make the STANDARD AUTOMATIC SAW GUAGE an article of much merit."
 WRITE TO
 SPECIALTY MFG. CO.
 DETROIT
 Mich.

Garlock Packing Co.

HAMITON - - - CANADA

—SOLE MANUFACTURERS OF—



GARLOCK'S PACKINGS

PATENTED

Asbestos and Mineral Wool Pipe and Boiler Coverings, Engineers' Supplies in General



THE CANADA LUMBERMAN AND WOOD-WORKER

VOLUME XXV.
NUMBER 6.

TORONTO, MONTREAL — JULY, 1905 — WINNIPEG, VANCOUVER

TERMS, \$1.00 PER YEAR
Single Copies, 10 Cents

TO PREVENT SAP STAIN IN LUMBER.

At the request of a subscriber, we have endeavored to obtain some information regarding the possibility of successfully preventing sap stain in lumber. Our investigations show that many experiments have been made but that most processes which have been successful are too expensive.

The Lumber Anti-Stain Company, of Sault Ste. Marie, Mich., have a process which consists of dipping the lumber in its undressed condition into a tank containing a certain chemical in a solution of water, or if preferred sprinkling with same instead of dipping. This is done when the lumber is in its undressed

state. It is piled after treatment, and any sap in the lumber, whether on the edge or across the face of the board, is thus prevented from staining and the lumber comes out white and bright. This process is very simple and we understand quite successful, but taking into consideration the royalty and the expense of doing the work, it is not generally considered advantageous.

The Yawkey Lumber Company, of Hazelhurst, Wis., experimented about three years ago with a system of putting sap lumber into vats and steaming it, but they did not carry their investigations into general practice. They found that by piling their lumber in a

more open manner it did not stain and consequently concluded that the expense of steaming was unnecessary. They have exceptionally good piling ground and get very little stained lumber.

A method of steaming lumber to prevent stain has been adopted by the Daniel Shaw Lumber Company, of Eau Claire, Wis. They load, say, 1,500 feet of lumber on to rollers and stick the lumber with ordinary lath, make the load four feet wide, then provide a steam box large enough to hold the load and fitted with iron rollers on the bottom. The load is then rolled into the steamer, the door closed, live steam turned on and the lumber boiled for



BRITISH COLUMBIA MILLS; TIMBER AND TRADING COMPANY'S ROYAL CITY PLANING MILLS, VANCOUVER.

1. Portion of storage warehouse for ready-made house sections. This building will accommodate enough sections to put together 50 average sized houses. 2. Cut-off saws at end of each planer in planing mill. 3. Local dressed lumber shed. 4. Interior of planing mill. 5. Portion of fitting and erecting shed, 55 x 155 ft. 6. Stationary engine, which is provided with a drum and 800 feet of 3/4-inch steel cable, which is used for the purpose of hauling the lumber kiln trucks to their respective planers, and of special advantage in the event of fire, it being capable of emptying the six kilns of their complement of 36 trucks, containing approximately 325,000 feet of lumber, in the short space of fifteen minutes. 7. Factory bench room. 8. Grinding room. 9. Interior of sash and door factory.

THE Canada Lumberman

AND WOOD-WORKER

(Monthly and Weekly Editions—One Dollar Per Year.)

PUBLISHED BY

The C. H. Mortimer Publishing Company
of Toronto, Limited,

CONFEDERATION LIFE BUILDING, TORONTO

BRANCH OFFICES:

38 ALLIANCE BUILDING, MONTREAL
720-721 UNION BANK BUILDING, WINNIPEG
22 GREAT ST. HELENS, LONDON, E. C.
536 HASTINGS STREET, SUITE 3, VANCOUVER, B. C.

The LUMBERMAN Weekly Edition is published every Wednesday, and the Monthly Edition on the 1st day of every month.

TERMS OF SUBSCRIPTION:

One Copy, Weekly and Monthly, One year, in advance, \$1.00
One Copy, Weekly and Monthly, Six Months, in advance, 50

Foreign Subscription, \$2.00 a Year

ADVERTISING RATES ON APPLICATION.

THE CANADA LUMBERMAN AND WOOD-WORKER is published in the interest of and reaches regularly persons engaged in every part of Canada in the lumber, wood-working and allied industries. It aims at giving full and timely information on all subjects touching these interests, and invites free discussion by its readers.

Special care is taken to secure for publication in the WEEKLY LUMBERMAN the latest and most trustworthy market quotations throughout the world, so as to afford to the trade at home and abroad information on which it can rely in its operations.

Advertisers will receive careful attention and liberal treatment. For manufacturing and supply firms wishing to bring their goods to the attention of owners and operators of saw and planing mills, wood-working factories, pulp mills, etc., the CANADA LUMBERMAN AND WOOD-WORKER is undoubtedly the most direct and profitable advertising medium. Special attention is directed to "WANTED" and "FOR SALE" advertisements, which are inserted in a conspicuous position on front page of the Weekly Edition.

PERMANENCY OF TIMBER LIMIT REGULATIONS.

An unauthorized statement that the Quebec Government had decided to increase the stumpage charge on timber has recently caused some concern to persons not well informed on the subject. Were such a step contemplated, the licensees might have good ground for objection, but we are officially advised that the question of increasing the dues has not been seriously considered. Indeed, the Quebec Government have given the lumbermen an assurance of permanency and stability in the regulations by guaranteeing that for the next five years at least there will be no change in the charge either for ground rent or stumpage dues. The section of the Order-in-Council making such provision reads as follows:

"The present rate of ground rent for licenses to cut timber shall not be increased until the first of September, 1910, and all license holders who have conformed and shall conform to the regulations concerning the administration and sale of timber on Crown lands shall have, up to that date, the privilege of renewing their licenses at the same rate of ground rent; and the dues now exacted by the regulations on all timber cut in virtue of a license shall not be increased before the said date of first of September, 1910."

It is quite improbable that the administrators of Quebec timber lands are at the present time considering the regulations which shall apply five years hence, for the expediency of such regulations would depend largely upon the condition of the lumber trade at that time. Meanwhile the Order-in-Council quoted above should be sufficient.

The Quebec Government are also to be commended for repealing the Act in respect to the granting of land to the parents of twelve

living children. About a year ago the Legislature amended the Act and made it possible for all parents of twelve children to select a hundred acres in the licensed timber limit nearest their domicile, and the limit holder might then, upon payment of \$50, secure for fifteen years an ownership of that hundred acres clear of all charges. This amendment was taken advantage of by persons who did not require the land but who saw an opportunity of getting \$50. The result was that timber limit owners were compelled to pay \$50 to a great number of applicants. It is said that in one instance, that of Price Bros., a firm holding limits near a thickly settled district, sufficient applications for homesteads on their land were received to take up three times the area of the limits. The legislative body saw the injustice of the law and repealed the amended Act.

THE PRACTICE OF ECONOMY IN LUMBERING.

Few branches of industry offer greater opportunities than the lumber trade for the practice of those economies upon which depend so largely the success of nearly all business enterprises. The many prosperous sawmilling establishments in Canada stand as evidence that in the adoption of economical methods of manufacture the lumbermen have kept pace with the march of progress, and it may be predicted that in this respect they will in the future continue to be among the leaders. To what extent modern appliances have been adopted may be ascertained by a comparison of the sawmill of to-day with that of but a few years ago.

It would be a mistake to assume, however, that lumbering had reached perfection, for a little observation shows that there is still room for improvement. Greater attention should be given to the adoption of methods and machinery which will result in a saving in timber, for notwithstanding the very commendable policy of establishing forest reserves which is now being recognized by all Governments, it is doubtful whether the increment will be equal to the consumption. If otherwise, the value of timber must increase.

The use of the axe in felling trees results in more waste than if the saw were employed. Would the universal adoption of the saw in lumbering operations not be an advance step?

The necessity of cutting the trees as closely as possible to the ground is recognized by most lumbermen, but it is difficult to find axemen who duly appreciate this fact, and frequently several inches of the best timber is left on the stump. Here a considerable saving might be made.

The modern sawmill represents a very complete establishment, and were all mills modern, the waste product capable of profitable utilization would not be very great. Many of the smaller and more poorly equipped mills, however, still allow too much good timber to go unmarketed. This might be remedied to some extent, we believe, by the cutting of a greater percentage of small dimension stock.

A question of vital interest to lumber manufacturers and also pertinent to the subject under

consideration, was discussed at the recent meeting of the Hardwood Manufacturers' Association of the United States. It was the cutting of lumber to the standard widths of 4, 6, 8, 10 and 12 inch and lengths of 10, 12, 14 and 16 feet, etc. It was pointed out that, besides the waste of timber, this method cost much to the manufacturer in the course of a year. Where a board is but a little short of 16 feet, nearly two feet has to be cut off to bring it down to 14 feet. The same applies to the width. A committee recommended the adoption of standard widths of 3, 4, 5, 6, 7, 8, 9, 10, 11, 12 inches and wider, and the addition of the odd foot lengths between the minimum and maximum lengths now in use. It is improbable that any attempt will be made to put the change into effect immediately, but it is almost certain to come, and is but another illustration of the economies which are being practised by the lumber trade.

TENDENCY OF STUMPAGE AND LUMBER PRICES.

That eminent American forester, Dr. D. E. Fernow, recently read before the American Association for the Advancement of Science a most interesting paper entitled "The Movement of Wood Prices and Its Influence on Forest Treatment". He reviewed in a very masterly way the trend of lumber and stumpage values since the early part of the nineteenth century and submitted some conclusions which are worthy of consideration by lumbermen. The statements presented indicate two things very clearly, first, that the advance in the price of lumber does not represent a greater profit to the manufacturer, and, secondly, that as the timber supply on this continent becomes reduced, prices of stumpage and lumber are likely to advance until they are higher than those now prevailing in European countries.

As affecting the first question, it is shown that the stumpage of white pine in Michigan rose during the twenty years from 1866 to 1886, by constant steps without a break from one dollar per thousand feet to between \$4.50 and \$6.50, while white pine log run lumber fluctuated during the whole period only between \$11.50 at the beginning and \$13 at the end, being never higher than \$14 and for five years of that period sinking as low as \$10. It will thus be seen that lumber prices do not move proportionately with stumpage, due to the fact that the price of a manufactured product like lumber is influenced by the competition of manufacturers, cost of labor and transportation and by new supplies becoming available.

As is generally known, the price of timber stumpage has been steadily increasing for the last century, and during the last ten years the increase has been very marked throughout the whole world. The Prussian Government is the owner of over 6,000,000 acres of timber land, and as it has been carefully managed for one hundred years or more, the results of operation are obtainable. The present annual cut is between 250,000,000 and 300,000,000 cubic feet, the total sales representing from \$13,000,000 to \$15,000,000 annually. This timber is not sold in the stump but is cut into log lengths. It is estimated that from 1830 to 1903 the

stumpage value increased at the rate of 1½ per cent. annually, that is to say, the prices of stumpage are double what they were fifty years ago and nearly treble what they were at the beginning of the period.

Dr. Fernow concludes that stumpage prices are now rising relatively faster than lumber prices and that as knowledge of the conditions of supply in the world grows, prices will everywhere rise at an accelerated rate until that level has been reached which forces reduction of consumption. That practical business men share this belief may be inferred from the policy of certain timber limit owners. In the state of Mississippi half a million acres of the best pine land are held by three owners for the future rise of prices, these owners refusing today three dollars per thousand feet, when elsewhere in accessible situations two dollars is considered a fair price. The present average stumpage price in Europe is ten dollars per thousand feet board measure.

Dr. Fernow's concluding remarks are: "All the evidence seems to lead to the conclusion that knowledge of available supplies is increasing and exercising its influence, and that a more rapid rise of wood prices than in the past is to be anticipated."

SAW TEETH.

By J. W. MOODY.

Probably there is no branch of the wood-working industry in which there has been such vast strides of progress as in the fitting of saw teeth on the various types of saws of the splitting type, such as log bands and circulars, band and circular resaws, etc.

There was a time when a circular saw was but little more than a round disc with a serrated edge. Space, hook, gullet and outline entered into the calculation of the filer to a very limited extent, in those primitive days of the rotary mill. Bye and bye along came the upset and bar swages, which were a step toward intelligence, inasmuch as the teeth were spread to a chisel point at the end. The points were, however, more or less irregular both in symmetry and amount of swage, in spite of skilful handling, and were usually side-filed,



HANCHETT BAND SAW SWAGE.

to injure a smooth cutting saw. With these primitive tools such fitting consumed a vast amount of time with the disadvantage of weak corners.

Next came the machine or eccentric swage. Here was a progression indeed. We have often noticed illustrated advertisements of this tool with a supposed likeness of the tooth produced. Some in fact do produce such a tooth and it may suit some filers; but it is not what I consider an ideal form.

The ductility of the steel from which saws are all made at the present day enables one to mould the point of the tooth into a shape which is absolutely ideal for the work intended, provided of course that one has a swage of the proper make. I have found nothing equal

to the products turned out by the Hanchett Swage Works, of Big Rapids, Mich. The steel is forced to a convex outline, giving strength clear across the cutting edge, and the lips are not thin and weak but have a sufficient amount of metal to add still further to strength. Nothing short of nails or stones break such corners. This swage allows for making a tooth with a long side cut, which is particularly adapted to gummy woods, or for making a pin pointed corner for hard-woods, and the spread may be obtained with equal facility in either case.

But even with this tool, unless it is in the hands of a very expert workman, there will be found a slight variation in the spread of different teeth. This is not a mark of demerit, and detracts in no way from the value of the tool. Swages are designed to spread only, and when one has one that will perform the operation as quickly and as scientifically as the Hanchett swage, there should be no more desired.

The company, however, being alive to the conditions of the lumber industry, have recently put on the market a swage shaper that makes a fitting companion to the swage. I think I was one of the first enjoying the privilege of trying one of these shapers, and I must say that five minutes was sufficient to convince me of the superiority of this tool. It not only does all that the makers claim for it, but does it more quickly. There is absolutely no excuse for finding fault with it, as the spread may be regulated to an infinitesimal degree, the

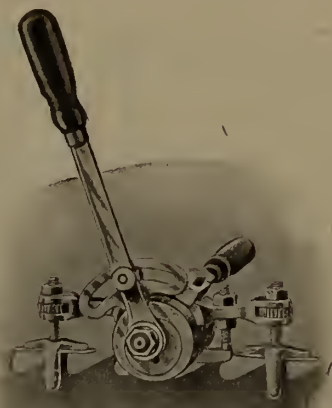

HANCHETT BAND SWAGE SHAPER.

lever operating the dies being adjustable to any position, without changing the position of the dies, and no matter how much compression is sought the swage is not crumpled up or hurt in any way. The rapidity with which one may operate the shaper is little short of wonderful. I have swaged and shaped to seven gauges for special work and not having time to compress back to the usual five gauges, resaw kiln dried quartered oak as smoothly as one could wish.

I counsel filers who anticipate either both or one of such tools to try the Hanchett.

THE KINCAID ROLLER BEARING.

Engineers, manufacturers and others using power will be interested in a new roller bearing which has been placed on the market. The inventor of this bearing is Mr. John Kincaid, of Vancouver, B.C., who has been working on it for several years and has brought it to its present state of perfection.

Many good things are claimed by the inventor for this bearing. While it is called a roller bearing and is that in every sense, yet it is constructed on entirely new and original lines. One of the advantages, which a glance at the illustration makes clear, is the dispensing with collars on the shaft, the cones themselves preventing a sliding motion to the shaft.

The Kincaid roller bearing, as it is called, is claimed to be universal in its application to anything that may be properly termed a journal bearing, effecting a saving of over 160 per cent. of friction and 75 per cent. of oil.

The ends of the spindle, upon which the rollers are distributed, engage in a frame ring made in segments, for the purpose of application and removal, which maintain their distance apart and prevent the rollers

coming in contact with each other as in the case of ball bearings.

A few of the advantages claimed for the bearing are the following: (1) The roller grooves in the box being cast on a "chill", insure a hard wearing surface for the rollers. (2) The "box" being cast in one piece and dowel pins fitted in before breaking apart, insures a perfect alignment of the roller grooves. (3) The double cone rollers are arranged in double series to eliminate any possibility of cross-winding, their distance

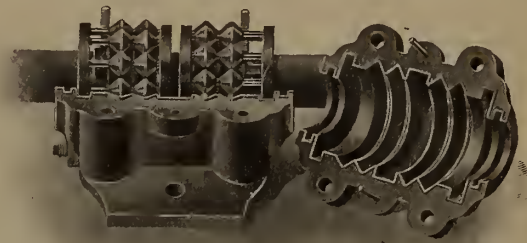

The Pillow Block Type of Bearing Showing Rollers in Double Series.

apart being maintained by a frame ring at each end of the box, in which the ends of the roller spindles are engaged. (4) The sleeve is closely fitted to the journal, and firmly locked in position, but can be removed at any time if desired without disturbing other attachments on the shaft. Both sleeve and rollers are of steel, fully hardened and tempered, thereby prolonging their utility. (5) The self oiling attachment and oil chamber in the box are designed to eliminate the need of frequent oiling or the usual waste of oil. A patent dust-proof ring is also a strong feature with the bearing. (6) The peculiar form of the rollers renders them particularly adaptable for end thrusts and this itself ought to make it an extremely welcome invention.

A number of tests have been conducted and when tested in the same way and under precisely the same conditions, the Kincaid indicated, it is claimed, a saving of 162 per cent. of power over the ordinary type of babbitted bearing.

PACIFIC COAST EXCURSIONS.

During June, July, August and September the Chicago and North Western Railway will sell from Chicago round trip excursion tickets to San Francisco,

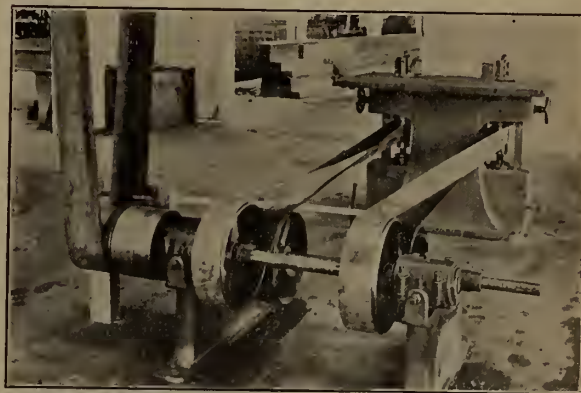

A corner in the B. C. Electric Railway car shops, New Westminster showing the Kincaid roller bearings in position. This shaft makes about 1300 revolutions per minute.

Los Angeles, Portland, Ore., (Lewis & Clarke Exposition), Seattle, Victoria and Vancouver at very low rates. Correspondingly cheap fares from all points in Canada. Choice of routes, best of train service, favorable stopovers and liberal return limits. Rates, folders and full information can be obtained from B. H. Bennett, General Agent, 2 East King St., Toronto, Ont.

The James Warnock Company, Limited, of Galt, Ont., have recently acquired the business of James Warnock & Company, and will continue in a much larger way the manufacture of lumbering tools in which Warnock & Company have acquired so wide and enviable a reputation. The new company have just disposed of their spring business and will replace their spring plant with a new and entirely modern lumbering tool plant. Within six months the James Warnock Company, Limited, will be in a position to supply their numerous customers with tools of the highest possible grade in any quantities they desire.



MIDLAND THE SOURCE OF A GREAT CONCATENATION

The concatenation which was held under the auspices of the Hoo-Hoo members of Midland, Ont., on June 30th, will be chronicled in the annals of the Order as a most successful and enjoyable affair. The arrangements were complete, and all who anticipated a pleasant time had the satisfaction of its realization.

The visiting members and candidates from Toronto, London, Galt, Woodstock, Orillia, Chatham, Gravenhurst and other points reached Midland shortly after the noon hour, when they were met by a local deputation and shown around the town. The great centre of attraction, of course, was the magnificent saw mills, of which Midland is justly so proud. Where can four more complete mills be found? Two double-cutting bands and a circular comprise the sawing equipment of the Playfair & White mill, two double-cutting bands are to be found in Norman L. Playfair's mill and similar equipment in Geo. Chew & Son's mill, while Chew Bros. operate a circular and gang and double cutting band. These mills turn out lumber at the rate of upwards of 500,000 feet per day, which, estimating at fifteen logs to the thousand, means a daily consumption of 7,500 logs.

At 5 o'clock the party embarked upon steamers en route to Honey Harbor. In addition to the steamer "Maud", bearing the banner of the Hoo-Hoo Navigation Company, the private yachts of Dwight J. Turner and D. S. Pratt conveyed some of the members to the concatenation headquarters. The weather was warm and the sail on the Georgian Bay was delightful and much appreciated. If the craft had any sorrows they were all forgotten for the time. Arriving at Honey Harbor, the first duty of the party was to assemble for the group photograph which is here reproduced.

And now for the concatenation. The large dining room of the Hotel "Royal Honey Harbor" met the requirements splendidly. The "Supreme Nine" was represented by Supreme Arcanoper W. C. Laidlaw, of Toronto, while the Vicegerent Snark for Eastern Canada, Dan. Ferguson, of London, was present in his official capacity. The officers were:

Snark, D. Ferguson.
Senior Hoo-Hoo, D. L. White.
Junior Hoo-Hoo, J. G. Cane.
Bojum, W. Hadley.
Scrivenoter, O. H. Vogt.
Jabberwock, Ward Sutherland.
Custocatian, W. J. MacBeth.
Arcanoper, W. J. Hetherington.
Gurdon, H. J. Bartlett.

The blind kittens who had evinced a desire to walk in the light of Hoo-Hoo numbered sixteen, all good material. It was after 10 o'clock when they were permitted to enter the onion bed, which was fresh and green as the result of the abundant growth of the spring season, and when once commenced the work was lively enough for all, some of the kittens even showing fatigue while under tests of physical strength, such as "lung testing" and "fencing". The extras which were introduced as the result of the additional duties imposed upon the Scrivenoter were well carried out and the "Cornmeal" diet provided for the occasion has, according to report, had a stimulating effect upon the kittens. Despite the diffi-

culty of a number of the feats, all the candidates were successful in reaching the goal, and finally did honor in an audible way to the Sacred Cat with its benign tail. Below is the list:—

W. J. Martin (W. J. Martin & Company), Hillsdale.
H. G. Cooke (W. Cooke & Sons), Hillsdale.
A. E. Clarkson (Playfair & White), Midland.
W. R. Spooner (Turner Lumber Company), Midland.
C. R. Shaw (H. H. Hettler Lumber Company), Midland.
L. J. Regan (Playfair & White), Midland.
Frank Bartholemew (Tanner Bros.), Tannerville.
A. M. Matthews (Matthews Bros.), Toronto.
W. P. Dempsey (Chicago & Northwestern Ry.), Toronto.
Jas. McLaughlin (Cataract Refining Company), Toronto.
J. R. Somers (Wm. Laking Lumber Company), Toronto.
Thos. Patterson (Patterson-Tilley Company), Hamilton.
G. H. Long (Long Lumber Company), Hamilton.



SOME OF THE HOO-HOO AT THE HONEY HARBOR CONCATENATION, JUNE 30, 1905.

M. H. Haney (Skillings, Whitneys & Barnes), Orillia.
David Anderson, Waverley.
A. R. C. Smith (Conger Lumber Company), Moon Falls.

After the concatenation a "Session on the Roof" was held, at which a bounteous repast was served, and during which an orchestra dispersed sweet music. The menu was printed on birch bark and the songs of the evening on sheets of sulphite wood pulp furnished by the Riordan Paper Mills of Merriton, Ont. At each plate were two souvenirs, one being a paper weight in the form of a miniature iron car wheel for tram service, and bearing the compliments of the Midland Engine Works Company; the other a steel watch chain of neat design on which are shown a file, band saw, shingle saw, circular saw and cross-cut saw, this being the gift of Henry Disston & Sons, of Philadelphia, through their Canadian manager, W. E. Radcliff.

Vicegerent Snark Ferguson presided at the banquet, and after congratulating the local members upon the efficient arrangements made for the entertainment of the visitors, called upon Mayor D. L. White for an address. The remarks of the Mayor were warmly received. They contained a further offer of hospitality and

an expression of those sentiments which bring the fraternity of lumber interests closer together. Then followed a musical programme, contributed by W. W. Scane, Ward Sutherland, Jas. McLaughlin, A. G. Breed, the Chatham Quartette, and others. Some contributed poems were read by W. C. Laidlaw, and the singing of "God Save the King" closed one of the most enjoyable meetings which has been held by the Hoo-Hoo of Canada, for which much credit is due the local members. We must especially compliment Frank Moores for his efficient work.

The party returned to Midland by steamer early Saturday morning and left for their respective homes. Among those present to witness the concatenation were the following:

J. C. Anderson (Mickle-Dyment Co.), Gravenhurst.
A. G. Breed (Firstbrook Box Co.), Penetanguishene.
H. J. Bartlett (Skillings, Whitneys & Barnes), Orillia.
W. S. Borland (Geo. Borland & Son), Coldwater.
C. Bailey (Wm. Jessop & Sons), Toronto.
Dr. Boyd, Coldwater.
W. W. Carter, Fesserton.
J. G. Cane (J. G. Cane & Co.), Toronto.
W. C. Cooke (Wm. Cooke & Sons), Hillsdale.
R. E. Carter (W. W. Carter), Fesserton.
Manley Chew (Geo. Chew & Sons), Midland.
Geo. Clipsham (Clipsham & Sons), Gravenhurst.
Wm. A. Dunn (Boake Manufacturing Co.), Toronto.
D. Ferguson (Ferguson Lumber Co.), London.
W. A. Hadley (S. Hadley Lumber Co.), Chatham.

W. J. Hetherington (Wm. Laking Lum. Co.), Toronto.
H. W. Hogue (Miracle Pressed Stone Co), Toronto.
S. R. Higgins (J. G. Cane & Co.), Toronto.
W. C. Laidlaw (R. Laidlaw Lumber Co.), Toronto.
Alex. Leishman (The Rathbun Co.), Orillia.
E. Long (E. Long Manufacturing Co.), Orillia.
Wm. Lord (Georgian Bay Lumber Co.), Waubaushene.
J. T. Laking (Wm. Laking Lumber Co.), Hamilton.
W. J. Lovering (W. J. Lovering & Co.), Toronto.
Frank Moores (Playfair & White), Midland.
A. A. Mowry (B. R. Mowry & Sons), Gravenhurst.
C. S. Mickle (Mickle-Dyment Co.), Gravenhurst.
W. J. MacBeth (J. D. Shier Lumber Co.), Toronto.
T. E. Milburn, Toronto.
F. P. Potvin (Georgian Bay Shook Mills), Midland.
N. L. Playfair, Midland.
D. S. Pratt, Midland.
J. P. Regan, Atherley.
W. E. Radcliff (Henry Disston & Sons), Toronto.
D. W. Sutherland (MacGregor-Gourlay Co.), Galt.
W. W. Scane, Chatham.
H. Turnbull (W. J. Lovering & Co.), Orillia.
C. D. Ten Eyck (E. C. Atkins & Co.), Toronto.
Dwight J. Turner (Turner Lumber Co.), Midland.
O. H. Vogt (Shurley & Dietrich), Galt.
D. L. White (Playfair & White), Midland.
Neil Watson, Mull.
T. S. Young (CANADA LUMBERMAN), Toronto.

Vicegerent Snark D. Ferguson, of London, is organizing a party to attend the annual meeting at Portland, Oregon, in September.

SOME SUBJECTS OF INTEREST TO LUMBERMEN OF THE MARITIME PROVINCES

THE ST. JOHN RIVER LOG DRIVING DISPUTE.

The trouble between the stream drivers of the Upper St. John river and the owners of the booms in regard to which the dispute arose, reached a crisis on Saturday, May 27th, when Mr. Levi Pond, the veteran driver, arrived at Van Buren with the corporation drive. Finding that the booms of the Van Buren Lumber Company interfered with the course of his drive, Mr. Pond promptly blew up one with dynamite and was about to treat the next one in a similar way when a party composed chiefly of the employees of the Van Buren Lumber Company, armed with rifles, ordered him to desist and threatened him with instant death if he persisted.

As this demonstration took place on the Canadian side, Mr. Pond sent a New Brunswick constable to arrest one of the leaders of the beligerents. The constable was met by half a dozen of the rival party who defied him and threatened him with rifles. The constable then withdrew.

Mr. Pond hung his drive just above the



MR. LEVI POND,
The Veteran Contractor for Log Driving.

booms and went to St. John, leaving his men in camp. On the shore a half mile below and in the immediate vicinity of the booms, the lumber company's men camped, prepared, so it was said, to meet with firearms any attempt to cut the booms.

In the meantime navigation upon that part of the river was blocked and a very important portion of last winter's cut of logs belonging to the mill owners at St. John and along the river were hung just above Van Buren.

A few days later the Van Buren Lumber Company extended the olive branch, their manager, Mr. Allen Hammond, agreeing to meet the wishes of Mr. Pond rather than prolong the strife. He assured the latter that the booms would be tripped, thus allowing a clear passage for boats. If it became necessary for the company to use their sheer booms again before Mr. Pond had finished his driving operations, the company agreed to anchor them some distance from the shore, so that there would always be a clear passage.

Mr. Pond is a man well advanced in years, but is of a fearless, determined character, and was convinced that he had right on his side.

As contractor for the Madawaska Log Driving Company, having charge of the drive from the Allegash River to Grand Falls, he is not



FIG. 1.—NEW LOGGING CAR FOR DAVISON LUMBER COMPANY, BRIDGEWATER, N. S.

supposed to know whose logs are floating in the river, his duty being simply to drive the logs left remaining in the river or on its banks. If one mill owner diverts the logs of his neighbor towards his own mill he contends that it is none of his concern. That is a matter for the mill owners to settle between themselves. But in order to drive the logs in the river it is necessary for him to go up and down the river with his crew accompanied by tow-boats and bateaux, and he claimed that he had the right to do so and could remove any obstruction that impeded his passage.

NEW LOGGING CARS.

Messrs. Rhodes, Curry & Company, of Amherst, N.S., have built some logging cars of special design for the Springfield Railway, which is owned by the Davison Lumber Company, of Bridgewater, N.S. They are 35 feet in length and are equipped with the cross logging attachment. This attachment consists of four bed plates, preferably 56 lb. rails, which are spaced and secured to side sills with

admit 1-1/4" steel pins. The stakes are of mild steel 2-3/4" sq. rounded at bottom and are fitted with 1-1/4" steel pins which are inserted in grooves of stake holders mentioned above. From top of floor upwards the stakes are taper drawn to give shape and strength. Extreme length of stake is four feet. These

stakes are connected with shackle and 1/2" best chain 12" above floor. This chain is drawn across car and passes through a malleable iron lock bracket as shown in Fig. 1. This bracket is secured to car body with bolts and is fitted with a lock bar made of mild steel drawn to 7/8" sides and back and 1/2" front, ends bent parallel to form a loop, so that when lock is inserted it grips the chain and is held in this position with cotter pins. It will be seen by Fig. 1 that stakes and bed chains are placed directly opposite at end of bed plates.

There are three additional lock brackets placed on each side of the car to which are attached binding chains 1/2" B.B. 20 ft. long. This attachment can be removed at a very small cost if car is desired for other service.

To discharge loaded logs the operator, after removing binding chains, will go to the right side of the car, remove cotter pins in lock bars and with a sharp blow of a hammer on projecting end of lock bars loosen the chain and allow it to pass rapidly up through lock brackets, allowing stakes to fall in position as



FIG. 2.—NEW LOGGING CAR FOR DAVISON LUMBER COMPANY, BRIDGEWATER, N. S.

bolts. They are intended to make easy the discharging of logs and give clearance to stake pockets and other projections on side of car, also to give clearance between floor and logs for bed chains.

The stake holders are made of malleable iron and secured to side sills with four 3/4" bolts. The holders are slotted to admit full size of stake on front and grooved on sides to

shown in Fig. 2. Logs can be discharged as readily from one side as the other.

The Gordon Hollow Blast Grate Company, of Greenville, Michigan, the well-known manufacturers of hollow blast grates, edgers and trimmers, inform us that they are crowded to their utmost capacity, the volume of their business breaking all records. The sales of their grates are especially large. This is due to the fact that there is no better investment for any sawmill that is not getting all the steam it requires.

DE LOACH GANG EDGERS.

The belt feed so commonly used on edgers is unsatisfactory, as the belt stretches, the surface of the small driving spindle is insufficient and the result is a source of continued vexation and expense to the mill man. For these reasons the DeLoach Mill Manufacturing Company, of Atlanta, Georgia, decided to equip their edgers with variable feed and three rolls driven, which they believe possesses many advantages. Concerning their edgers they say:

"All of our gang edgers, five sizes, are now equipped with this feed, which affords a complete remedy for the annoyance and delay known to exist with a belt feed,

their operation. The two frames carrying the two top rolls are so connected that the weight of the two top rolls and their frames is added to the roll doing the work. A power friction controlled by one hand of the operator raises the top rolls simultaneously, and a 1-2 inch drop on variation is allowed in each roll to accommodate any unevenness in the thickness of the lumber. The two bottom rolls are driven by friction with a worm gear connection and a heavy roller sprocket chain. The husk frames are very heavy and made so that the mandrel boxes on the rear side of the machine can be quickly removed for changing the saws.

"The lumber guide is made in two pieces of seasoned

there being less friction and consequently less wear. These brass guides are made with oil fountains, which afford a constant lubrication where they fit in the groove of the saw collar. Attached to the front end of the machine in plain view of the operator is a table, to which is attached spring latches that engage in notches in the hand wheels 1-4 inch apart, controlling the saws. An individual scale for each saw is mounted on this table, by which the exact distance between all the saws is plainly indicated at all times without it being necessary for the operator to make any calculations. The extended tables are fitted with wrought pipe rollers, one end placed a little in advance of the other, which forces the lumber snugly against the guide."



DE LOACH "IMPERIAL" GANG EDGER.

in addition to which it gives a complete variation of the feed to correspond with the power, thickness of the lumber and number of saws used. As on our planers, the variable friction feed is used in connection with a worm gear and we call especial attention to the great power we have thus developed and to its remarkable simplicity.

"In addition to the above improvement, we present a new feature in the four feed rolls and the manner of

oak timber, hinged together so it can be thrown in to blind the back saw for temporary use. It is mounted on two small head blocks and operated by means of two rack pinions and shaft running the full length, making it very rigid and reliable. The guides for the saws are controlled in the same manner. They are made of brass and fitted to the saw collars, which reduce the lost motion to a minimum and operate easier than if they worked on the outer edge of the saws,

Saw mill men may obtain any further particulars desired by addressing the manufacturers.

Mr. W. F. Hanbury, son of Mr. John Hanbury, the well known lumberman of Brandon, Man., has completed his term at the Toronto Technical School and left last month for the Pacific Coast, where he will be associated with his father's saw-milling enterprise at Elko, B.C.

SPECIAL TO LUMBERMEN, MINERS AND RAILWAY CONTRACTORS



We are Manufacturers of

**MINCE MEAT, BAKING POWDER,
COFFEE, SPICES, FLAVORING
EXTRACTS, MUSTARDS, &c.**

And all kinds of Grocers' Sundries
for Camp Use.

Mince Meat put up in 75 pound Tubs, ½
Barrel about 300 pounds, Barrels about
600 pounds.

Special Attention Given to Mail Orders

The Capstan Manufacturing Co., TORONTO,
ONT., CAN.

SCRIBNER'S LUMBER AND LOG BOOK

A handy book for Lumbermen,
Gives Correct Measurements of
Scantlings, Boards and Planks;
Cubical Contents of Square and
Round Timber; Doyle's Rules,
and much other practical infor-
mation.

Price 35 Cents

Address:

The Canada Lumberman
TORONTO, ONT.

PAT. OSCILLATING BOB SLED KNEE

Hauls 25 per cent. easier, and wears longer, and
is lighter than all others.

THOMPSON MFG. CO., Ltd.,
Grand Bay, N. B.

Please mention the CANADA LUM-
BERMAN when corresponding
with advertisers.

"STERLING" OILS

FOR SAW MILLS

WE SOLICIT ORDERS

TRADE LARGE AND SATISFACTORY

OUR AGENTS WILL CALL WITH "STERLING" CYLINDER,
ENGINE, DYNAMO, MACHINE AND SPECIALTY OILS

*Greases, Packing, Waste, "Copperine," Ready Mixed Paints,
Varnish, Red and Black Roof Paint; Smoke Stack Black for Boiler
Fronts and Sawmill Refuse Burners, White Lead, Dry Colors, Etc.*

Canadian Oil Co., Limited
Strachan Avenue, TORONTO, ONT.

Galt Machine Knife Works



MACHINE KNIVES

OF EVERY DESCRIPTION

FOR

Woodworking Machines

... Send for Price List ...

The Peter Hay Knife Co., Limited - Galt, Ont.

CANADA LUMBERMAN

AND WOOD-WORKER

WEEKLY EDITION

The Lumberman Monthly Edition. 44 pages} \$1.00 PER YEAR {The Lumberman Weekly Edition every week.

THIS PAPER REACHES REGULARLY THE PRINCIPAL LUMBER MANUFACTURERS AND DEALERS THROUGHOUT CANADA, AND WHOLESALE BUYERS IN GREAT BRITAIN, THE UNITED STATES, AND OTHER FOREIGN MARKETS.

VOL. XIII

TORONTO, MONTREAL — JULY 5, 1905 — WINNIPEG, VANCOUVER

No. 18

CANADA LUMBERMAN

PUBLISHED BY

The G. H. Mortimer Publishing Co'y
of Toronto, Limited

Confederation Life Building - TORONTO.

Branch Offices:

38 ALLIANCE BUILDING, MONTREAL

720-721 UNION BANK BUILDING, WINNIPEG.
Telephone 1274

536 HASTINGS ST., SUITE 3, VANCOUVER, B. C.
22 GREAT ST. HELEN'S, LONDON, E. C.

The Weekly Lumberman — Published every Wednesday, contains reliable and up-to-date reports of market conditions and tendencies in the principal manufacturing districts and leading domestic and foreign wholesale markets. A weekly medium of information and communication between Canadian timber and lumber manufacturers and exporters and the purchasers of timber products at home and abroad.

The Monthly Lumberman — A 44-page journal, discussing fully and impartially subjects pertinent to the lumber and wood-working industries.

WANTED AND FOR SALE

Advertisements will be inserted in this department at the rate of 15 cents per line each insertion. When four or more consecutive insertions are ordered a discount of 25 per cent. will be allowed. This notice shows the width of the line and is set in Nonpareil type; 12 lines make one inch. Advertisements must be received not later than 4 o'clock p. m. on Tuesday to insure insertion in the current week's issue.

FOR SALE — LARGE QUANTITY OF 3"
Common Spruce, Barge or car lots. Apply
Box 111, CANADA LUMBERMAN, Toronto, Ont.

ENGINE—12"x18", SHAPING, HANGERS,
Pulleys, Joints, Double Surfacers and Re-
saw; a snap. C. R. PETERKIN, 150 Bay Street,
Toronto.

WANTED—1", 1 1/4", 2" COMMON BEECH,
Birch and Hard Maple 5/4 Beech C & B.
1", 6/4" 2" Wormy Chestnut. All dry. R. E.
KINSMAN, Hamilton, Ont.

FOR SALE.

SMALL STEAM SAW MILL WITH DOUBLE
Edger and Cut-off Saw; capacity, eight to
ten thousand feet per day. Also a timber
license of sixteen square miles; mill built in
center of the limit; any quantity of timber;
reason for selling, going out of the business;
price three thousand dollars. Address Box 75,
Powassan.

FOR SALE

1" and 1 1/4" 1904 winter cut, mill run, trimmed
Hard Maple.
1" 1904 winter cut, mill run, rough edged, Hard
Maple.
1" 1905 winter cut, trimmed, all pure White Hard
Maple.
1", 1 1/4" and 2" 1905 winter cut, mill run, trimmed
Hard Maple.
Write for lists and prices. The W. R. THOMP-
SON Co., Teeswater, Ont.

FOR SALE

OVER FOUR MILLION FEET OF STAND-
ING timber and land composed of chest-
nut, whitewood, oak, ash, maple, basswood,
elm, beech, with 10 M capacity mill; 3 railways
running through property; good market for
cordwood, tile wood, stove wood, hubs, spokes
and everything in the product of a sawmill—
including planing and matching machine,
shingle machi e, and moulding machine; con-
taining 350 acres; will be sold either in whole or
part. Railway spur on property; the best lot
of timber in these parts. Original forest. J.
C. SCHLEHAUF, Owner, Bismarck Station,
West Lorne P. O., Ont

500 CORDS DRY HEMLOCK SLABS FOR
sale. THE STANDARD LUMBER &
STONE Co., Longford Mills, Ont.

WANTED—ALL PULP MILLS AND PULP
WOOD Companies to look up page 7
monthly issue, which is bound to interest you.

WANTED — TEN THOUSAND CORDS
Hard and Soft Wood; also same quantity
of Slabs. SIMCOE WOOD AND LUMBER Co., 52
Yonge Street Arcade, Toronto.

FOR SALE

SMALL HARD-WOOD SAW-MILL AND
STANDING TIMBER: good opening for
man with small capital. Box 231, CANADA
LUMBERMAN, Toronto.

LUMBERMEN—YOUNG MAN WITH GOOD
business and mechanical training from
stump to lumber pile wants position. Will take
junior place if ability ensures steady work and
promotion. Address Box 220, c/o CANADA LUM-
BERMAN.

FOR SALE AT ONCE

COMPLETE PLANING MILL OUTFIT,
including Boiler 56" x 12" and Climax
Engine 9 1/2" x 12", all new. MANITOU LUMBER
Co., North Bay, Ont.

FOR SALE—150,000 FT. BEECH, 500,000
ft. hemlock. Can be cut to order. 200,000
ft. 1", 6/4", 8/4" and 3" soft elm, 2,000,000 ft.
cedar, 20,000 ft. 4 x 4 cedar, 10 cars X X X.
cedar shingles. Rail or water shipments. PED-
WELL & LEMCKE, Lions Head, Ont.

WANTED—GANG FILER AND HELPER,
Gang Sawyer, 2 each Circular Sawyers
and Setters, 4 Carriage Riders, 2 Edgermen, 1
Crane Man for Gang, 3 Trimmers, 1 extra
utility man. Season 8 to 9 months. Apply to
F. COLEMAN, Mill Superintendent Springfield,
N. S., care of DAVISON LUMBER Co., LIMITED.

FOR SALE—WHITE PINE

1 CAR 12x12 AND UP, NO. 1, 2 AND 3 COM-
MON, 80% 13" and up, 1 car Basswood, all
bone dry. JOHN M. SHAW, Forest, Ont.

HAVE YOU ANY STOCK WHICH YOU
wish to sell? If so, make the fact known to
probable buyers by placing an advertisement in
the Wanted and For Sale Department of this
journal. Address, CANADA LUMBERMAN, To-
ronto.

FOR SALE

75 M 4/4 SOFT HLM DRY; 75 M 4/4 Bass Dry;
100 M 4/4 Maple Dry; 20 M 8/4 Maple Dry;
20 M 8/4 Birch Dry; 20 M 4/4 Birch Dry; 10 M 4/4
Soft Maple Dry. Prices and terms on applica-
tion. A. P. EBERT, Warton, Ont.

FOR SALE AT A BARGAIN—NO. 3 HAM-
ILTON Carriage steam feed, 7 1/2" cylin-
ders and all connections, circular outfit com-
plete with iron husk, mandrill, etc. Two
boilers 22 feet long, 4 feet in diameter, six boilers
20 feet long and 4 feet in diameter, two 14"
flues in each Full Second Hand Outfit for Cir-
cular Mill. THE ONTARIO LUMBER COMPANY,
LIMITED, Toronto, Ont.

TIMBER LIMIT FOR SALE

SPLENDID CEDAR AND HARDWOOD
Timber Limit, up-to-date mill with gun-
shot feed, trimmers and other full equipment;
sufficient timber to run 10 years; mill now in
full operation, located on Georgian Bay; good
shipping facilities output practically sold for
several years. Box 230, CANADA LUMBERMAN
Toronto.

POSITION WANTED—BY W. PINE LUM-
BER Inspector, as Buyer or Inspector.
Address Box 233, CANADA LUMBERMAN.

WANTED—TO HEAR FROM SOME FIRM
requiring Maple Squares, or Table Legs.
Address EDGAR A. WOODMAN, ROSSVILLE, York
Co., N. B.

FOR SALE—A 30 FOOT WATEROUS GUN-
shot steam feed, 9" cylinder, in good con-
dition, used only a few months. For particu-
lars apply to MADISON WILLIAMS, Port Perry,
Ont.

CEDAR FOR SALE — 10,000 PCS. ROUND
Cedar 8-16 and 25 feet long, at the Spanish
boom. Also cedar, pine and spruce lumber for
sale here at Larchwood. JAMES MCCREARY,
Larchwood, Ont.

FOR SALE CHEAP—ONE GOOD DOUBLE
Cylinder Set of 24 in. Cards and Picker,
also one run "Roller Process" Grist Mill Ma-
chinery Outfit complete. Address EDGAR A.
WOODMAN, ROSSVILLE, York Co., N. B.

WANTED AT MIDLAND.

AN EXPERIENCED SHIPPER WHO UN-
derstands the English export grades. Ap-
ply, THE TURNER LUMBER Co., LIMITED, Mid-
land, Ont.

CURRENT TRADE CONDITIONS.

ONTARIO.

The lumber market is showing some indications of midsummer quietness but without any impairment of its strong tone. The manufacturers appear to have the utmost confidence in the stability of conditions and are showing no disposition to cut prices. A large percentage of this season's production of white pine lumber has already been contracted for, and this, notwithstanding that one or two of the largest wholesale dealers have contracted for considerably less stock than during the corresponding months last year. A visit to some of the largest manufacturing points on the Georgian Bay shows that there is not a great deal of white pine which has not already passed out of first hands. During the past week we have been told of increased inquiries for stock for export to Great Britain, and if the next few weeks should witness an improvement in this direction the lumber trade would be greatly encouraged. Shipping is not active, the present time being between seasons; the old stock is nearly all shipped out and much of the new stock is not yet in shipping condition. Many manufacturers are watching the hemlock market very closely, but we have not learned of any disposition to sacrifice stock, the general opinion being that hemlock is still too cheap.

Birch and basswood represent the two extreme conditions of the hardwood trade. The former is very strong and active, while the latter is almost correspondingly weak and quiet. Considering the slump in basswood prices which has taken place during the past few months, some recovery would seem to be in order.

QUEBEC AND NEW BRUNSWICK.

As the result of the strike of carpenters in Montreal, the movement of lumber in that city has slackened, and if it should continue for any length of time, the effect upon the local lumber market will be quite unfavorable. An early settlement is looked for, however, when building operations will be resumed with increased activity and the lumber demand revive accordingly. Prices of most kinds of lumber are firm. Perhaps the feature of the market is the demand for birch both for home consumption and export. The returns show that 197,600 cubic feet of birch and maple timber was received at Quebec up to June 30th of this year, as compared with 111,960 cubic feet for the corresponding period of 1904. Elm also shows a much larger production, the figures for this year being 399,000 cubic feet, as compared with 131,000 cubic feet in 1904 and 216,000 cubic feet in 1903. The quantity of wane white pine received at Quebec is about 100,000 cubic feet less than last year.

Reports from the Upper St. John River indicate more favorable log driving conditions during the last ten days. Considerable rain has fallen and the river has risen materially. The probabilities now are that the estimates as to the total volume of the hang-up of logs will have to be modified somewhat in order to be correct. The opinion prevalent among those well versed in these matters is that the figures will aggregate from 25,000,000 to 30,000,000 feet, which amount is participated in by perhaps a score of operators.

While a hang-up of these dimensions is bound to cause a scarcity of logs in several cases, most of those interested have enough in safe water to supply their mills for the greater part of the manufacturing season. Again, it is possible that much of the quantity mentioned might come forward later, although such an event would require remarkably heavy rains.

UNITED STATES.

The lumber trade of the United States continues to reflect most satisfactory conditions. Although the demand is not as heavy as in the spring season, still there is no accumulation of stock, and orders are being refused on account of inability to supply seasoned material. Much of the lumber in the yards is still too green for shipment. The shipments of white pine lumber from Minneapolis for the first three weeks in June were greater than in any other year since 1901, which is an indication that manufacturers have marketed a large quantity of stock this year. The demand for white pine for building operations is enormous and if it should keep up

until well into the fall some items of pine are almost certain to advance in price. Hemlock is in fair supply but is going rapidly into consumption, dimension having the greatest call. Notwithstanding that hardwoods do not exhibit as much strength as pine, nothing but an optimistic view can be taken of the future of that market. Considering the cost of production, prices are relatively low and manufacturers will hold their stock rather than sell below present prices. The strongest items are plain-sawed white and red oak, birch and ash. There is also a fair enquiry for elm. The hardwood flooring people are enjoying a good trade and many of them find the capacity of their factory taxed to the utmost. Red cedar shingles are practically unchanged, but in some markets are showing signs of a little more strength.

GREAT BRITIAN.

British importers of lumber still seem to lack confidence, and although the quantity contracted for is exceptionally small, very little business is being done. The London consumption shows a marked falling off as compared with one year ago, and the publication of the figures has caused buyers to be even more cautious. Recent sales of White Sea lumber have been made on a basis of £8 for third quality deals, which represents a considerable drop from the prices which were asked earlier in the year. It is a question if importers have not become too pessimistic, as they are likely to discover a considerable shortage in the supply towards the approach of winter. It may then be too late to acquire stocks, whereas those who purchase at prevailing prices and carry the lumber for a short time are likely to profit thereby. When the present war is finally terminated, the lumber trade will doubtless improve. Pine deals have been selling slowly, as few shippers have made any concession in price. Red pine deals are not finding favor and are difficult to dispose of. Spruce deals have been offering freely and have declined slightly in price, recent sales having been made at £7 5s per standard c.i.f. Liverpool. There is a better demand for hemlock deals, and birch logs are in fair demand. Heavy consignments of American oak planks have been received at London, with the result that prices have weakened.

STOCKS AND PRICES.

Mill run norway at Ashland, Wis., is bringing from \$15.50 to \$16.50 and No. 3 and better inch about \$19.

The H. M. Loud's Sons Company, of Au Sadle, Mich., have sold 2,000,000 feet of hemlock timber to come to Ontario for heavy work.

John M. Chisholm, of Winnipeg, has been awarded the contract for lumber and building supplies for Stoney Mountain Penitentiary for the next fiscal year.

Montgomery Bros. & Company, of Buffalo, have found box lumber so scarce lately that they brought a canal boat load from Tonawanda and have kiln dried some of it to keep their mill running.

The work at the booms at Fredericton, N. B., has been completed. The total rafting operations for the season, unless there is a raise of water sufficient to bring out some more logs, at the Mitchell, Douglas and Sugar Island booms this year will be about 48,000,000 feet.

The Scott Lumber Company, of Fredericton, N. B., have received word that the corporation drive on the St. Francis river is out. The logs, however, will be hung up on the Maine St. John. Charles Miller has some 8,000,000 feet in the drive, the Scott Company 2,000,000 feet and Edgecombe & Eaton about 15,000,000 feet.

Following is a comparative statement of timber, etc., measured and culled at Quebec up to July 4th, as reported by the Supervisor of Cullers :

	1903	1904	1905
Waney White Pine..	611,480	987,880	£83,640
White Pine.....	80,600	69,920	61,440
Red Pine.....	40	3,000	920
Oak.....	380,640	121,760	9,680
Elm.....	216,000	131,400	399,200
Ash.....	34,160	12,240	8,720
Butternut.....			120
Birch and Maple....	132,840	111,960	197,500

The schooner Carisande, with fence posts and shingles for Port Stanley, Ont., ran on the docks in the Detroit river and was taken into the dry dock at Detroit as the result. The steamer Shamrock, with a cargo of lath from Midland, Ont., to Toledo, Ohio, became waterlogged on Lake Huron and was abandoned by her crew. She was picked up later by another steamer and towed into Alpena.

Concerning basswood a Wisconsin manufacturer says: "My experience is that the demand shows some improvement. Lately we have been getting as much as \$33 for firsts and seconds, \$23 for No. 1 common and \$16 for No. 2 common. This is about \$1.50 over the list. I find that cull, or No. 2 common basswood, is a ready seller at \$16. To-day I sold 1,500,000 feet of straight mill cull at \$15 Chicago delivery, which is 50 cents above the list. I understand that some sales of basswood are being made in Chicago at \$2 less than the prices I have quoted, but I think that if those having basswood will carefully look into the market they will find that there is no necessity for selling at less prices than the above. Our company has been buying basswood right along and we are confident that it will be much higher in price this fall. We are not urging it on the market at present, believing it good stock to hold.

From Messrs. S. P. Musson, Son & Company's review of the Barbados market we extract the following:

We have no arrivals to report during the fortnight, but understand that a couple of cargoes of white pine are expected, which will meet with a very flat market, as dealers are well supplied with this description, and will expect to make further purchases at reduced prices. Spruce is not in heavy stock, but as the crop is virtually over, the demand for this is light, and next arrivals would probably not realize late values. Receipts of shingles have been nil, but we shall no doubt soon receive shipments of Long Cedar from Gaspé, and as stocks of these are very small, first arrivals should sell well. Cedar laying on the other hand are in full supply, and a cargo of these which is near at hand will meet with a rather dull market.

W. C. CRAWFORD

Tilbury Ont.
Manufacturer of . . .

Handles—Axe, Fork, Pick, Etc.

Also Hard and Soft Wood Heading, and Red and White Oak, Maple and Elm Lumber.

Can supply Second Growth White or Red Oak squares up to 38 in. long in large quantities.

FIRES.

A woodworking factory at Sackville, N. B., owned by A. B. & S. Copp, was destroyed by fire last week.

ARTHUR A. WATT
WIARTON, ONT.

Dealer in Hard and Soft Wood, Lumber, Lath, Shingles, Cedar Posts and Ties

SPECIAL—50,000 4/4, 8/4 and 12/4 Soft Elm 30,000 8/4 Maple, C & B.; 18,000 4/4 Soft Maple 100,000 4/4 M. R. Basswood; 18,000 4/4 Mill Run Pine Sidings, 40,000 4/4 and 8/4 Birch; 40,000 6/4 Beech. Prices on application.

A SPLENDID ROUTE.

The Wisconsin Central Railway is justly termed the "Sportman's Line" because it reaches into and through the very heart of the choicest hunting grounds in America.

The very best wild fowl shooting of the entire North is reached ONLY by this line. Hundreds of beautiful lakes abounding in wild rice and celery attracts myriads of ducks and geese and afford the finest kind of cover and the choicest shooting to be found the country over.

The Wisconsin Central Railway caters especially to the sporting public and during the various seasons for hunting and fishing furnishes daily information to its patrons as to local conditions anywhere along its lines upon application to the nearest ticket agent. It also arranges its train service with special reference to the convenience and comfort of sportsmen, and its employes are constantly on the alert to make travel over their lines pleasant and comfortable.

This line offers the best route between Chicago, St. Paul, Milwaukee, Minneapolis or to Lake Superior points via Ashland, Wisconsin.

Information given by addressing—

JAS. C. POND, Wis. Cent. R. R. Milwaukee,

HELP!

Can be obtained at small cost by advertising in the Want Columns of THE WEEKLY CANADA LUMBERMAN.

WOODS & SPICER, Limited

.....MANUFACTURERS OF.....

BRITISH COLUMBIA RED CEDAR SHINGLES

Capacity 100 Million a Year.

We have had over 15 Years Experience, and are not Asking our Competitors for any Pointers as to Quality.

Wire Your Orders at OUR EXPENSE to Agents, or to us at VANCOUVER, B. C.

KNIGHT BROTHERS CO. LIMITED
Burk's Falls, Ont.

KILN-DRIED BIRCH FLOORING

Send for Catalogue
* * * Samples by Mail

KNIGHT BROTHERS CO. LIMITED
Burk's Falls.

Keenan Bros., Limited

Owen Sound, Ont.

HARDWOOD, HEMLOCK AND PINE LUMBER

We carry a full supply of native Hardwoods always on hand and solicit your inquiries. At the present time we have piled at outside points about 2,000,000 feet of Hardwoods, and about the same quantity of Hardwood, Hemlock and Pine piled here in Owen Sound, and we should be able to interest you if in the market.

WILL MAKE SPECIAL PRICES ON
BROKEN LOTS AT OUTSIDE POINTS

Planing and Matching

—IN TRANSIT—

S. POMEROY, Orillia

PLANING, MATCHING, RESAWING,
SIDING, FLOORING, MOULDINGS

in Car Lots.

Factory near Station. Write for Prices.
*Phone 113

MASON, GORDON & CO.

WHOLESALE TIMBER

Montreal, Quebec

Eastern Agents The B. C. Mills, Timber & Trading Co., Vancouver, B. C.

DOUGLAS FIR Timber in any size or length supplied
WRITE FOR PARTICULARS AND QUOTATIONS.

EVERYTHING IN LUMBER AND TIMBER

DRESSED AND IN THE ROUGH

BULMER, McLENNAN & COMPANY

MONTREAL QUE.

Office and Yard, 571 DORCHESTER ST.

P.O. Box 116

REDUCED RATES ON SHINGLES.

The Great Northern Railway has decided to meet the through rate quoted by the Canadian Pacific Railway on shingles from the Pacific Coast to the East. Following is a comparison of the old and new rates from Seattle and Puget Sound points:

	Old.	New.
Oshawa, Ont.....	\$.80½	\$.78½
St. Catharines, Ont.....	.75	.72½
Peterboro, Ont.....	.82½	.80
Sarnia, Ont.....	.72½	.71
Montreal, Que.....	.82	.80
St. Johns, Que.....	.87	.82
Point Levis, Que.....	.90	.82

British Columbia shingle manufacturers who have always held the market of Eastern Canada hitherto do not fear the effect of this new tariff on their business. They hold that having had this rate since 1903 they have been giving an advantage to the trade, and now that the Great Northern has merely met the rate it is not a menace to their business. It is also their claim that the shingle product of British Columbia is superior to that of Puget Sound mills, which will help them to hold their trade.

BUFFALO LUMBER RECEIPTS.

BUFFALO, June 20th, 1905.—The lake trade has been for the most part confined to pine for this port, and, though there will be a revival of the movement of lake hardwood, it will not be so great as it was expected to be some time ago, as there was an overstock of it in certain quarters. Scarcely anything arrived by lake in April, as the ice held the fleet back. Now, with a fair amount in there is something of a

lull and freights are very dull. Following is the list to June 1:

	Season		
	May, 1905	1905	1904
Lumber feet . . .	20,356,000	20,906,000	5,654,000
Shingles number .	28,977,000	30,647,000	725,000
Lath, pieces . . .	339,500	336,500	3,075,000

It will be seen that shingles are prominent now, as lath was early last season. The shingle trade is demoralized by the sending out of a host of consignment lots from the Pacific coast, which were shipped on the supposition that the demand was good and they could all be sold on the way. The demand is good, but not good enough to absorb all that came this way, so quite a good part of the shipment had to be sacrificed. The movement has now steadied down somewhat, but prices are still low. Lath is very scarce and high. The big lake movement of it last spring did not last, so there is not now much chance of its amounting to much.

LUMBER CONDITIONS IN MICHIGAN.

Excessively wet weather during May and for the most of June has somewhat interfered with the lumber business at Bay City and Saginaw, making it difficult to handle lumber to advantage. In general, however, the volume of business is fairly good and prices for white pine are firmly held. In fact, coarse lumber used particularly in the manufacture of box shooks is held at such prices for pine that box manufacturers are using hemlock and basswood culls for shooks, and the same can be bought at considerably less prices than pine is held at. Mill culls of pine are worth \$14 and \$15, while basswood culls, which make good box shooks, have been bought at \$8 and \$10.

Pine dealers are getting in supplies, the receipts during May being much larger than they were for the same month last year. There came into the Saginaw river during May 18,829,056 feet of pine lumber, of which 12,744,066 feet went to dealers in Bay City and 6,085,000 feet to Saginaw dealers. Indications now are that the receipts of lumber here this season by lake will be fully as large as last year. Handy Brothers bought 15,000,000 feet at Duluth, which is now coming along, the firm having chartered a steamer that brings down over a million feet at a trip. The bulk of the lumber coming here comes from the Georgian Bay district. Mershon, Schuette, Parker & Company have received a few cargoes and more is coming along.

The hardwood business is fairly good and manufacturers and dealers state that it is not difficult to sell lumber. Maple has not been quite so firm, but it is moving well, and when converted into flooring brings \$3 a thousand more than it did last year. The flooring firms all report a fair business and all are busy. Basswood, elm and ash are doing very well and are firmly held.

There is a good demand for hemlock and it sells rapidly. There has been very little accumulation of hemlock owing to the demands of the trade, and some firms are selling stock green from the saw.—New York Lumber Trades Journal.

Many persons are always in the market for lumber, and the manufacturer or dealer who advertises what stock he has for sale is certain to get more business than his too conservative competitor. If you wish to get the best results from

advertising, place your announcements in the "Wanted and For Sale" Department of the CANADA LUMBERMAN Weekly Edition.

The Cleveland-Sarnia Saw Mills Co., Limited.

Manufacturers and Wholesale Dealers in

Timber, Lumber, Lath and White Pine Shingles

Special Bills Cut to Order in White Pine, Norway and Fir, any length from 10' to 60' long.

SARNIA, ONT.

M. & L. Samuel, Benjamin & Co. 503 Temple Building, Toronto. EXPORT DEPARTMENT.

Correspondence solicited with exporters of wooden goods, such as Sanitary Woodware, Broom Handles, Fork and Shovel Handles, Turned Goods, etc. Payments made on receipt of Bill of Lading at Toronto. European House SAMUEL SONS & BENJAMIN, 16 Philpot Lane, London, Eng.

J. B. Farwell & Son
CONTRACTORS AND DEALERS IN . .

Canadian Cedar Telegraph, Telephone and Electric Light Poles
Bancroft, Ont., and Oswego, N.Y.

FOR SALE
Exceptionally good Birch and Hemlock Lumber f.o.b. car South River Station. Mills at Midford (Eagle Lake) Ont.
THE ROBB LUMBER CO., LIMITED
Guelph, Ont.

Hunter, Crawford & Niebergall
(Successors to R. Watt)
LUMBER AND SQUARE TIMBER OF ALL KINDS
POSTS, POLES, TIES, LATH AND SHINGLES
Bill Stuff a Specialty **WIARTON, ONT.**
Write Us for Hard and Soft Wood Slabs.

THE IMPERIAL LUMBER CO., LIMITED
SAW AND PLANING MILLS, WARREN, ONT.
RED AND WHITE PINE DEALS
All kinds of **SAWN LUMBER** By Carload or Cargo.
Registered Cable Address, "Pinewood." "American Lumberman" Telecode.
BRANCH OFFICE, MANCHESTER, ENG.
Head Office, **TORONTO, CAN.**

SAGINAW LUMBER & SALT CO.
MANUFACTURERS OF
LUMBER AND SALT
Mills at Sandwich, Ont.
R. H. ROYS, Pres.
RALPH LOVELAND, Vice-Pres.
C. A. KENT, Sec'y.
R. S. ABBOTT, Treas.
SAGINAW, MICH.

BANK ST. CHAMBERS OTTAWA, ONTARIO
W. B. BARTRAM
WHOLESALE LUMBER AND TIMBER MERCHANT
White Pine, Quebec Spruce and Hardwood.
Special Bills sawn on short notice. Barge or car load lots
All Inquiries Given Prompt Attention.

J. GORDON MACLAREN
HINTONBURG, ONT.
DIMENSION TIMBER { In Spruce, White and Red Pine, up to 40 feet.
 { In Douglas Fir, up to 90 feet.
Every inquiry receives our Prompt attention.
Write for quotations. B. C. Cedar Shingles
SASH - DOORS - BLINDS

J. D. SHIER LUMBER CO., LIMITED
BRACEBRIDGE, ONT.
MANUFACTURERS OF
LUMBER, LATH AND SHINGLES
Pine, Hardwood and Hemlock Floorings and Ceilings. Sash and Doors, Wood Turnings etc. All Dressed Lumber Kiln Dried if desired End Matched Flooring a Specialty.
GOOD PINE SIDINGS A SPECIALTY
Planing, Matching, Resawing, etc In Car Lots.
Manufacturer of
Doors, Sash, Mouldings, Ceilings
End-Matched and Bored **HARDWOOD FLOORING** A SPECIALTY.
Lumber Kiln Dried in Any Quantity.
J. R. EATON - Orillia, Ont.
Correspondence Solicited. Phone No. 54.

CEDAR POLES
5,000 pieces, 10 to 20' long. Suitable for Hops, etc.
Price ?—Well write us.
THE LONG LUMBER COMPANY
HAMILTON

CACHE BAY LUMBER INDUSTRIES.

Geo. Gordon & Co.,
Manufacturers of RED and WHITE PINE
Band - Gang Circular **LUMBER**
AND **LATH**
CACHE BAY, Ont.
C. P. R. 26 miles West North Bay

CARTER POWELL LAND & LUMBER CO., LIMITED
604 Temple Building, Toronto
To **MILLMEN**—Cash buyers all kinds **HARDWOODS**
Cable address "Quartered Toronto." Codes, A. B. C., 5th and Lumberman's

Please mention this paper when corresponding with advertisers.

Cedar Cove Mill,
Vancouver, B.C.

E. H. HEAPS & CO.,

Ruskin Mill
Ruskin, B. C.

Vancouver, B. C.

Lumber, Lath, Shingles, Doors, Mouldings, Etc.

SPECIALTIES :

AA1 HIGH GRADE CEDAR SHINGLES.

Cedar Bevelled Siding, Cedar Door and Sash Stock, cut to size, Cedar Finish, Base, Casing, Newels, Balusters, etc. Douglas Fir Timber up to 85 feet in length.

W. J. SHEPPARD, PRESIDENT
Waubushene, Ont.

J. G. SCOTT, GENERAL MANAGER
Vancouver, B.C.

Pacific Coast Lumber Co.

LIMITED

VANCOUVER, B.C.

MANUFACTURERS OF

Fir, Cedar and Spruce Lumber, Lath, Mouldings, Turned Work, Etc. High Grade Red Cedar Shingles

Ontario Representative, W. J. LOVERING,

112 Mail Building, TORONTO

D. C. CAMERON, President and Manager.

WM. ROBERTSON, Secretary.

J. E. YOUNG, Cashier

The Rat Portage Lumber Co., Ltd.

Manufacturers
of

White and Red Pine Lumber, Lath, Shingles, Sash, Doors, Turned and Band Saw Work

Dealers in CEDAR POSTS, POLES and TAMARAC PILING

Mills at RAT PORTAGE and RAINY RIVER, Ontario, WINNIPEG, Manitoba, and VANCOUVER, British Columbia. Head Office: RAT PORTAGE, Ontario

Our Vancouver Mill cuts High-Grade Cedar, Fir, Spruce and Red Cedar Shingles. Winnipeg Mills cut Pine, Tamarac and Spruce Lumber
We also Manufacture all kinds of Mouldings, Sash, Doors, Turned Work and Boxes. Correspondence solicited at all four points.

Export Lumber & Shingle Co., Limited Vancouver, B. C.

We are Exclusive Selling Agents in Canada
for 40 per cent. of the Shingles manufac-
tured in British Columbia. Daily shipping
capacity over 1 1/4 millions.

W. C. WELLS

PALLISER, B. C.

Manufacturer of
**High Grade Spruce, Fir, Cedar
and Lumber of all Descriptions.**

CORRESPONDENCE SOLICITED.

W. B. McKECHNIE, President.

C. MacRAE, Manager.

THE ALBERTA LUMBER CO., LIMITED Vancouver, B. C.

Manufacturers of

BRITISH COLUMBIA RED CEDAR

All sizes to 24 inches wide, by 24 feet long—CLEAR.
B. C. FIR—DIMENSION AND FINISH.

SCRIBNER'S LUMBER AND LOG BOOK

A handy book for Lumbermen. Gives Correct Measurements
of Scantlings, Boards and Planks; Cubical Contents of Square
and Round Timber; Doyle's Rules, and much other practi-
cal information.

Price 35 Cents

ADDRESS THE CANADA LUMBERMAN, TORONTO, ONT.

CANADIAN MANUFACTURERS and WHOLESALERS

THE PEMBROKE LUMBER CO.
PEMBROKE, ONT.

We make a specialty of Dimension Stock in Pine, Spruce and Hemlock, and solicit your enquiries.

DELAPLANTE - McBURNEY LUMBER CO.,
WHOLESALE

White Pine, Hemlock, Lath, Shingles

Stocks in Ontario at { Collingwood Midland Powassan Whitney Cartier Sturgeon Falls Callander North Bay

TORONTO OFFICE: Room 503 Manning Chambers.

Office, Yards and Docks, NORTH TONAWANDA, N. Y. Send us your enquiries

FOR Pine, Hemlock, or Hardwood, Lumber and Timber, Telegraph Poles, Ties, Posts, Lath, Shingles, Dressed Lumber, Sash, Doors, Interior Finish, End Matched and Bored Hardwood Flooring, etc., try

JOHN HARRISON & SONS COMPANY, LIMITED

We have a complete stock, two Saw Mills running in summer and one all winter. HEAD OFFICE, SAW AND PLANING MILLS, OWEN SOUND, ONT.

RHODES, CURRY & CO., Limited
LUMBER MERCHANTS.

Yards at Amherst, Little Forks, Sydney and Halifax. BUILDING MATERIAL of all kinds carried in stock. We are buyers of Ontario Basswood, Elm and Pine. Amherst, N.S.

Sawn and Hewn Spruce, Hemlock, Pine and Birch Timber, Spruce and Pine Boards and Plank, Birch and Ash Boards and Plank, Flooring, Shingles, etc.

JAMES J. MURPHY, Bank of Hochelaga Building **QUEBEC**

The Cook & Bros. Lumber Co. MANUFACTURERS OF
Of Ontario, Limited
MILLS at SPRAGUE, Algoma Dist., Ont. on "Soo" Branch C.P.R.
OFFICES { Manning Arcade, Toronto
Coristine Building, Montreal
And at Mills at Sprague.
White and Red Pine Lumber and Lath
Water Shipments

THE M. BRENNEN & SONS MANUFACTURING CO., LIMITED

Saw Mills at RAINY LAKE, Ontario. Planing Mill and Head Office: HAMILTON, Ontario.

THE NIPISSING LUMBER COMPANY, LIMITED

Mills at CACHE BAY and SPANISH RIVER, Ontario.

Manufacturers of and Wholesale Dealers in all kinds of LUMBER AND LATH

Both Railway Delivery and Water Shipments. Correspondence Solicited. The NIPISSING LUMBER CO., Limited Head Office: HAMILTON ONT.

AUGER & SON - Quebec
PULP WOOD AND TIES

Bought at Any Station. Also Dimension Timber, Sawn to Sizes, Telegraph Poles and Lumber.—Write Us.

A. F. BURY AUSTIN
WHOLESALE LUMBER and TIMBER
CANADA PINE

Bank of Ottawa Building, 224 St. James St., MONTREAL, CANADA
SPECIALTIES: Railway Bridge Timber and all kinds of Hardwoods; Ship Decking, Norway and White Pine, Dimension Timber, Norway Car Sills, Car Flooring, Telegraph Poles, Railway Ties, Oak and Whitewood, Planed and Rough Lumber, British Columbia Pine, Southern Pine, &c.; Birch Flooring, hollow back, and batted.

Eastern Agent for The Pacific Coast Lumber Company, Limited, Vancouver, B. C.
Douglas Fir: Timber in any size or length up to 90 feet long. Timber Planers face up to 24 inch x 30 inch.
Dry Kilns of large capacity. Rough and Dressed Lumber, Douglas Fir and Cedar.

WRITE FOR PARTICULARS AND QUOTATIONS.

R. LAIDLAW LUMBER CO.

18 Toronto Street, Toronto

JAS. PLAYFAIR. D. I. WHITE.
PLAYFAIR & WHITE
Manufacturers and Wholesale Dealers
LUMBER • LATH • SHINGLES

Contractors for Railway Supplies BILL TIMBER a Specialty MIDLAND, ONT

A. & P. WHITE Manufacturers of and Dealers in
Sawn and Planed Lumber, Dimension Timber. Joisting Car Sills, Car Flooring, Shingles and Lath.
PEMBROKE ONT.

GET YOUR LUMBER AND TIMBER FROM
PINE LUMBER COMPANY

(On C. P. R. Main line near Sudbury) PINE, ONT.

F. MCGIBBON & SONS, PENETANGUISHENE ONT.
Manufacturers of Pine, Hemlock and Hardwood Lumber, and dealers in Cordwood Hemlock Bills cut on short notice.

MAITLAND, RIXON & CO. OWEN SOUND, ONTARIO.
Manufacturers and Dealers
LUMBER LATH, TIES, POLES, SHINGLES, ETC.
Make a Specialty of Long Pine, Cedar and Hemlock Bill Stuff. We ship by C. P. R., G. T. R., and by Water.

Turner Lumber Co., Limited MANUFACTURERS
LUMBER and LATH
Shipments by Rail or Water. Midland, Ont.

HARDWOOD FLOORING
End Matched, Bored, Steel Polished, and Bundled
Send for Price List
A few cars of selected Maple and Birch and other Hardwoods at close price
THE SEAMAN KENT CO., Limited
160 Bay St. Toronto Factory, Meaford, Ont.

THE FOSS LUMBER COMPANY
WHOLESALE
BRITISH COLUMBIA FIR, SPRUCE AND CEDAR LUMBER, RED CEDAR SHINGLES
We Solicit Your Inquiries. J. F. FOSS, Manager. 624-625 Union Bank, Winnipeg, Man.

HARDWOOD FLOORING
MANUFACTURED IN
MAPLE, BIRCH, BEECH AND OAK
3/8, 5/8, 7/8, 1 1/8 and 1 3/8 inch thicknesses. Kiln-Dried, Hollow Backed, End Matched, Bored and Polished, bundled with wire baling. . . .
Also Stock fully machined for Spring Bed Frames and
ALL KINDS OF HARDWOOD LUMBER
J. S. FINDLAY OWEN SOUND, ONT

CANADIAN LUMBER SHIPMENTS.

From Montreal: Steamer Kensington, for Liverpool, 194 logs, by McArthur Export Lumber Co.; 21,013 pcs. deals, by Watson & Todd; 16,528 pcs. deals, by R. Cox & Co.; 3,539 pcs. boards, by McLaurin Bros. Steamer Virginian, for Liverpool, 1,090 pcs. boards, by Watson & Todd. Steamer Fremona, for London, 1,362 pcs. deals, by Watson & Todd. Steamer Montreal, for London, 3,656 pcs. planks, 11,991 pcs. deals, etc., by Cox, Long & Co.; 2,750 pcs. deals by W. & J. Sharples; 5,199 pcs. deals, by McArthur Export Lumber Co.; 164 logs by Dobell, Beckett & Co.; 16,903 pcs. lumber, 1,654 bdls. staves, 908 doors, 18,064 bdls. shooks, by Canadian Pacific Railway. Steamer Sarmatian, for London, 369 pcs. deals, by Watson & Todd; 696 bdls. staves, by Canadian Pacific Railway; 2,762 pcs. lumber, 4 cases doors, by Grand Trunk Railway; for Havre, 4,059 pcs. lumber, by Grand Trunk Railway. Steamer Corinthian, for Glasgow, 2,430 pcs. deals and boards, by E. H. Lemay; 2,467 pcs. deals, by R. Cox & Co.; 2,313 pcs. deals, by Dobell, Beckett & Co.; 1,409 pcs. deals and boards, by Canadian Pacific Railway. Steamer Tritonia, for Glasgow, 4,681 pcs. deals, 2,043 pcs. boards, 45 logs, 1,251 pcs. ends, by J. Burstall & Co.; 71 pcs. timber, by McArthur Export Co.; 1,753 pcs. deals by R. Cox & Co.; 118 logs, by W. & J. Sharples; 1,533 pcs. deals, etc., by E. H. Lemay, 667 pcs. deals, by Canadian Pacific Railway. Steamer Jacona, for Leith, 3,138 pcs. boards, 2,381 pcs. deals, by R. Cox & Co.; 7,354 pcs. boards, by Dobell, Beckett & Co.; 22,457 pcs. deals, by W. & J. Sharples. Steamer Dunmore Head, for Dublin, 2,758 pcs. deals, etc., by McArthur Export Co.; 1,234 pcs. deals, by McLaurin Bros.; 1,016 pcs. deals, by W. & J. Sharples. Steamer Yanariva, for

London, 1,414 pcs. deals, by McArthur Export Co.

From St. John, N.B.: Barque Adam W. Spies, for Rosario, 645,390 ft. boards, 25,969 ft. plank, 266,642 ft. scantling. Schooner Jennie C., for Westerly, 65,829 ft. boards, 150,000 laths, 450,000 cedar shingles. Schooner Harry Morris, for Boston, 91,250 ft. boards. Schooner Effie May, for Quincy, 40,199 ft. boards, 633,000 cedar shingles.

From Halifax, N.S.: Steamer Briardene, for Brow Head, 191,549 ft. spruce deals, value \$2,106; Steamer Oruro, for Demerara, 26,000 ft. pine boards, value \$400; 33,850 ft. spruce, value \$300; 25,532 ft. hemlock boards, by \$428, by Pickford & Black, agents. Steamer Almora, for Glasgow, 993,012 ft. spruce deals, value \$9,930; 30,048 ft. birch deals, value \$301; 13,248 ft. hemlock deals, value \$133; Steamer Sicily, for Liverpool, 216,295 ft. spruce deals, value \$2,800; 149,579 ft. hemlock deals, value \$1,362, by Furness, Withy & Co., agents. Steamer St. John City, for London, 113,427 ft. birch deals, value \$1,353; 153,966 ft. hemlock deals, value \$1,487, by Furness, Withy & Co., agents.

B.C. PINE IN ENGLAND.

This lumber, says the Timber News, of Liverpool, Eng., is now finding a wider market. A few consignments from time to time find their way to the London market, where it is sought after by a few importers, but Germany is now interesting herself in the wood—principally in the smaller sizes for "deckings," for which it is particularly suitable. The better qualities are bought for this purpose, and, when well manufactured, a nicer and more satisfactory wood cannot be found. Cargoes of timber and planks are sold periodically round the Coast. Large sailing ships are chartered to bring forward the stuff, which can be seen occasionally unloading in the Surrey Commercial Docks. The voyage from Vancouver generally takes five or six months, so there is plenty of time to sell before arrival.



GETTING AT THE BOTTOM OF IT

That's the thing to do --

Investigate a little and see if you are getting as good service, as good prices or as good stock as you ought to.

If you are not, then it is high time to let us hear from you—for we have the goods and are able to make a deal with you that will be satisfactory to all concerned.

The Red Deer Lumber Company
WINNIPEG, MAN.

UNITED STATES MANUFACTURERS AND WHOLESALERS

YOU
CAN
REACH
THE BONSAK LUMBER CO.
WHOLESALE HARDWOODS
ST. LOUIS
BY
RAIL, MAIL
WIRE OR
'PHONE

H. D. WIGGIN BOSTON, MASS.
89 STATE ST.
will inspect at mill and PAY CASH for
LOG RUN
Elm, Ash, Bass and other Hardwood
CORRESPONDENCE SOLICITED.

YELLOW PINE
We are in position to give first - class stock. Reasonable prices. Prompt shipments. Mills in Alabama, Mississippi and Arkansas.
MANN, WATSON & CO. Muskegon, Mich

HAEBERLE LUMBER CO.
Wholesale and Retail Dealer in
YELLOW PINE and OAK TIMBER
Large stock of Timbers and Bill Stuff carried in stock.
All sizes and lengths for immediate delivery.
Telephone No. 10 - Cedar Street, NIAGARA FALLS, N.Y.

THE ROBERT H. JENKS LUMBER CO.
CLEVELAND, OHIO
MANUFACTURERS AND WHOLESALERS OF
YELLOW PINE, POPLAR, HEMLOCK AND HARDWOODS
Yellow Pine Timbers a Specialty

Indiana Lumber & Veneer Co.
INDIANAPOLIS, IND.

Sawed and Sliced Quartered
Oak a Specialty **Veneers**
Correspondence Solicited.

FRANK C. BURY **BURY & NOBLE** **MASON A. NOBLE**
WHOLESALE LUMBER - DETROIT **MICHIGAN**
Send us your inquiries for Southern Yellow Pine.

McGLURE LUMBER GO.

Wholesale Dealers in . . .

Hardwood Lumber

Carry in Stock and Have for Sale

ASH, BASSWOOD, BEECH, BIRCH, BUTTERNUT, CHERRY, CHESTNUT, COTTONWOOD, CYPRESS, ELM, GUM, HICKORY, MAHOGANY, MAPLE, OAK, POPLAR, SYCAMORE, WALNUT, POLES (Oak, Hickory and Ash), RIMS and SPOKES (Oak and Hickory), OAK BENDING PLANK, OAK BILL STUFF, RAILWAY TIES.

Office and Yards: 520 to 530 Franklin St., DETROIT, MICH.

Correspondence Invited on All Hardwoods.

WISCONSIN HARDWOODS.

Of Wisconsin hardwoods the American Lumberman says:

Hardwoods are dull. Rock elm is in demand by the agricultural machinery factories, but soft elm is very quiet indeed. Most of this is used by furniture manufacturers and they are not buying, as they have considerable stock on hand. Besides, soft elm is not as plentiful now as five or six years ago. For instance, one firm cutting 2,000,000 feet of hardwoods this year reports 126,000 feet of elm, or only about 6 per cent. the bulk of its stock being birch, basswood and maple. A few years ago soft elm was about one-quarter of the total, but it is getting scarcer and many factories are using birch to the exclusion of elm. Soft elm always will be a favorite wood for certain classes of trade, but it is not as popular as it was at one time.

Maple and birch are selling to some extent, the first to implement concerns and the second to planing mills. There is some demand for ash, oak and basswood also, but there is more lumber than buyers. However, this seems to be a midsummer dullness only and trade will start up stronger than ever in the fall. Prices are firm and values steady.

BRITISH COLUMBIA NEWS.

B. F. Butler, of Sandpoint, and Robert Miller, of Rathdrum, have a tie contract on the Spokane and International Ry. It will require about 400,000 ties for the main lines, from the International line to Spokane. The contract amounts to over \$100,000.

A deal was recently concluded by which New Westminster parties purchased the sawmill at Chilliwack from the estate of Jacob Zink. The new owners are George Blakely and Peter Grant, of the T. J. Trapp & Co., and J. Rennie and Harry Pollard, late assistant millwright and sawyer at the Brunette sawmills. Mr. Blakeley states that the mill will be put in operation at once. At the figure given for it there is an excellent opportunity to make a good thing. Mr. Grant, with Messrs. Rennie and Pollard, will remove to Chilliwack.

Mayor Coburn, of Ladysmith, recently visited the cedar limits owned by the Ladysmith Lumber Company on Howe Sound.

A. P. Stevenson, who leased the mill of the Moyie Lumber Company at Moyie, B.C., and has purchased the logs in the boom, has commenced operations. There are upwards of two million feet of logs to be cut and it will take about two months to

complete the work. The capacity of the mill is about 50,000 feet per day. The lumber will be loaded and sent to the Hanbury planing mill at Elko just as it comes from the saw. Provided more logs can be procured the mill will be kept running until the end of the year. There are several parties already figuring on such a contract. The resumption of operations at this mill means much to Moyie.

The Canadian Timber & Sawmills, Ltd., have taken a step which will tend to their mill at Trout Lake operating at an early date. The mill was closed down in August last when it was generally conceded it was paying for itself, and a deadlock has remained ever since. The principal creditor of the company was E. L. Kinman, and the matter has been in litigation ever since the shutdown. It is now stated that Mr. Kinman has accepted an offer of settlement made by the company and that the mill will resume operations.

The formation is announced of a lumber company to be known as the Chilliwack Lumber Company, consisting wholly of New Westminster men. It is capitalized at \$10,000, and will, it is understood, take over the mills at Vedder Crossing, which will be reopened shortly. The board of the company is as follows: D. B. Hall, president; J. H. Ashwell, vice-president;

S. A. Cawley, secretary-treasurer; James Bailey, H. Gervan and S. Meller. Mr. Fraser, late of the Royal City Mills, will act as superintendent.

A deal of considerable importance was concluded last month. The Jenkins Lumber Company, of Blaine, has purchased on the North Arm of the Inlet timber limits containing about 130,000,000 feet. Messrs. Peers and Clement are now opening a camp there, and will carry on the work of logging the claim. The same company has limits comprising about 15,000,000 feet of timber at Howe Sound. A. J. Faber, of Vancouver, has opened another camp for the same firm farther up the coast.

A dispatch from Wilmer, B.C., dated June 17th, says: The Columbia River Lumber Company last week purchased a whole block of land in Athalmer, fronting on Main street and adjoining the river. It is given out that the company will erect a building 100 feet long to be used as a store and warehouse for their freight, from which the logging camps are to be supplied. It is now evident the company intend working a big force of men in this vicinity next season.

Cable address: "Dundonian, Dundee."

BERG & SON,
Timber and Wood Pulp
Agents and Brokers
DUNDEE, SCOTLAND

Contracts made between Shippers and Importers
Correspondence solicited

BRITISH WOOD BROKERS AND IMPORTERS

FARNWORTH & JARDINE

Wood Brokers and Measurers

Cable Address "Farnworth," Liverpool. 3 Dale St., 71 Regent Road **BOOTLE LIVERPOOL, ENG.**

F. A. Lightbody & Co.

8 Gordon Street - GLASGOW, SCOTLAND

WOOD BROKERS

Cable Address: "TENEBRIS," GLASGOW. Codes: A. B. C., A 1, "Zebra" and Private.

Agents for **CANADIAN WHITE PINE AND SPRUCE; Hardwoods in Log; Etc.**
Shipments handled to the best advantage to all ports in the United Kingdom. Correspondence Solicited.

LOUIS BAMBERGER, 2 Broad Street Building, LONDON, E. C.

IMPORTER OF Pine, Spruce and all Canadian Wood Goods
Telegraphic Address "Bellywood, London."

Are Open to Contract for Glued-Up BASSWOOD KEYBOARDS

ZEBRA CODE A. B. C. CODE DIRECTORY CODE

GELLIBRAND, HEYWOOD & CO.

Wood Agents and Brokers

Cable Address: "GELLICHT," LONDON 57 Gracechurch St. London, E.C. England

FELBER, JUCKER & CO.

Lumber Importers

MANCHESTER ENGLAND

Invite offers from Lumbermen for . . .

Spruce Deals and Battens, Spruce and Pine Floorings, Shooks, Sashes, Mouldings, Dowels, Broom Handles, Chair Stock, Seats, etc., or any Woods Suitable for English Market.

Telegraphic Address: FELBER MANCHESTER.

ASHTON & PETFORD

BISHOP LANE, - HULL, ENGLAND

BUYERS OF BOX SHOOKS

Invite correspondence from manufacturers who are in a position to export to Great Britain.

Cable address, "Shooks," Hull.
Codes—A. B. C. 4th Edition and Zebra.

JOSEPH OWEN & SONS, LTD.

Timber Importers

Cable Address "Owen Liverpool" Liverpool, Eng.

BUYERS OF

White Ash Logs and Planks.
Oak Logs and Planks.
Rock Maple Logs and Planks.
Rock Elm Logs.
Hickory Logs.

... ALSO ...

All classes of Lumber and Manufactured Wood Goods suitable for the English Market.

SMITH & TYRER - 14 Tithebarn Street, LIVERPOOL
.. WOOD AGENTS ..

Cable Address—"Walmer," Liverpool.
Halifax, N.S., Office—SMITH, TYRER & CO., Metropole Bldg., Hollis St. Halifax, N.S.

Edmiston & Mitchells
TIMBER BROKERS

Cable Address: "EDMISTON" Glasgow. 33 Renfield Street, GLASGOW

GANT & KEMP  **TIMBER BROKERS**

52 St. Enoch Square, GLASGOW

Cable Address: "TECTONA" Glasgow.
A 1 and A B C Codes used.

Telegrams and Cables: "Woodfeller, London."
Codes: Zebra, Western Union, Southards, and A. B. C. 4th and 5th Editions.

THOMPSON, BLOIS & CO.

Buyers of all Kinds of Lumber and Logs

17 GRACECHURCH STREET: LONDON, E. C.

Cash advances made against shipping documents.

Branches: MANCHESTER, HAMBURG.

JAMES WEBSTER & BROTHER
BOOTLE, LIVERPOOL, ENGLAND

TIMBER MERCHANTS

BUYERS OF Oak, Birch, Ash, Grey Elm Logs and Lumber, Elm Staves and Heading, Handles of all descriptions
Veneers A Specialty

ALFRED DOBELL & COMPANY
WOOD AGENTS AND BROKERS

Liverpool and London Chambers - LIVERPOOL, ENGLAND

CABLE ADDRESS "DOBELL LIVERPOOL"

THE ONTARIO LUMBER CO. LIMITED

MILLS: North Bay, C.P.R. and G.T.R. Delivery.

WHITE PINE LUMBER, LATH AND SHINGLES.

35 and 36 Home Life Building TORONTO, Ont. MILLS: French River, Georgian Bay Water Shipment Only.

PEDWELL & LEMCKE, Lions Head, Ontario

MANUFACTURERS OF

Pine, Hemlock and Hardwood Lumber, Shingles, Ties, Poles, Posts, Etc.

Rail or Water Shipments.

Correspondence Solicited.

CANADIAN LUMBER WANTED

We solicit consignments of long and short lumber from the Maritime Provinces and are prepared to purchase White Pine and Hardwoods in Ontario and Quebec.

ADDRESS:

CHAS. S. WENTWORTH & CO.

Room 510, 147 Milk St. BOSTON, MASS.

THE KING AND BARTLES LUMBER CO. PINE, POPLAR AND HARDWOODS

HEADQUARTERS: Citizens' Building, Cleveland, O. HARDWOOD DISTRIBUTING YARD: McMinnville, Tenn. We buy and sell Pine in Car and Cargo Lots.

McLennan Timber Land and Lumber Co., Limited

Selling Agency and Dealers in all kinds of Timber Lands.

Offices: Quebec, 131 St. Peter St. Ottawa, Room 9, Central Chambers.

GEO. G. GLADMAN MANUFACTURER OF WHITE PINE AND HEMLOCK LUMBER LATH AND SHINGLES

Mills at Smith's Bay Township of Carling

PARRY SOUND, ONT.

CORRESPONDENCE SOLICITED

WE have Three Millions of Hemlock, running in lengths from 10 to 24 feet, which we are prepared to cut in blocks of 50,000 feet or over.

THE WOODSTOCK LUMBER & MANUFACTURING CO.

Dealers in Pine, Hemlock and Hardwood Lumber.

WOODSTOCK, ONTARIO

A. P. EBERT

MANUFACTURER OF AND DEALER IN

Pine and Hardwood Lumber, Lath, Shingles, Posts, Broom Handles, and Short Hardwood Dimension Stock

WIARTON, ONT.

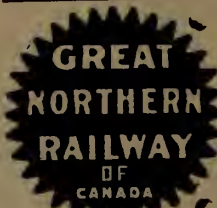

THE NEW LINE

Through the Spruce Forests of the Laurentian Mountains—between Quebec and Hawkesbury.

WATER-POWERS, TIMBER LIMITS AND ELECTRIC POWER FOR SALE. IDEAL PULP-MILL SITES.

Unexcelled Export Facilities at Quebec.

A. J. GORRIE, General Supt.

MONTREAL

GUY TOMBS G. F. & P. A.

CURRENT LUMBER PRICES--WHOLESALE

TORONTO, ONT.

CAR OR CARGO LOTS.

Table listing lumber prices for various types like 1 inch No. 1 Pine, 1 1/2 inch No. 2 Pine, etc., with prices in dollars and cents.

HARDWOODS--PER M. FEET CAR LOTS.

Table listing prices for hardwoods such as Elm, rock, mill, Hickory, etc., per M. feet car lots.

QUEBEC, QUE.

WHITE PINE--IN THE RAFT

Table listing prices for white pine in the raft, measured off and quality.

RED PINE--IN THE RAFT

Table listing prices for red pine in the raft, measured off and quality.

OAK--MICHIGAN AND OHIO.

Table listing prices for oak from Michigan and Ohio, by the dram.

ELM.

Table listing prices for elm, by the dram, according to average and quality.

ASH.

Table listing prices for ash, 10 inches and up, according to average and quality.

BIRCH.

Table listing prices for birch, 14 inch, 16 inch, and 17 inch.

OTTAWA, ONT.

MANUFACTURERS' PRICES.

Table listing manufacturers' prices for pine, good sidings, 1 inch x 8 inch, etc.

Table listing prices for pine good strips and pine good shorts.

Table listing prices for pine shorts 5' to 11' x 10", pine 8 up s. c. sidings, etc.

SARNIA, ONT.

Table listing prices for uppers and selects in Sarnia.

Table listing prices for fine, com. and better in Sarnia.

Table listing prices for fine common in Sarnia.

Table listing prices for No. 1 cuts in Sarnia.

Table listing prices for No. 2 cuts in Sarnia.

Table listing prices for No. 3 cuts in Sarnia.

Table listing prices for mill run in Sarnia.

Table listing prices for No. 1 barn, No. 2 barn, and No. 3 barn in Sarnia.

Table listing prices for boxes in Sarnia.

Table listing prices for mill culls in Sarnia.

Table listing prices for lath in Sarnia.

Table listing prices for shingles in Sarnia.

Table listing prices for lath in Sarnia.

Table listing prices for lath in Sarnia.

ALBANY, N.Y.

Table listing prices for pine, uppers, selects, fine common, etc., in Albany.

Table listing prices for lath and shingles in Buffalo and Tonawanda.

BUFFALO AND TONAWANDA, N.Y.

Table listing prices for white pine in Buffalo and Tonawanda.

The following quotations on hardwoods represent the jobber's buying price at Buffalo and Tonawanda:

Table listing prices for white ash in Buffalo and Tonawanda.

Table listing prices for black and brown ash in Buffalo and Tonawanda.

Table listing prices for birch in Buffalo and Tonawanda.

Table listing prices for maple in Buffalo and Tonawanda.

BOSTON, MASS.

Table listing prices for white pine uppers, selects, fine common, etc., in Boston.

WESTERN CANADA

Western Offices of The Canada Lumberman,
720-721 Union Bank Building, WINNIPEG, MAN.; 536 Hastings Street, VANCOUVER, B. C.

A TYPICAL ROCKY MOUNTAIN MILL.

One of the most beautiful sights ever unfolded to the vision of human eyes is that seen from the plant of the Fernie Lumber Company at Fernie, B.C. Situated in the very heart of the Rocky Mountains, encircled by a series of grand snow-clad peaks, the Fernie Lumber

famous Three Sisters, Mount Fernie (called after Bill Fernie, the founder of the town), Mount Sentinel, the Lizard Range and Cave Mountain.

The Crow's Nest Pass lumbering industry shows its greatest activity along the Elk river from the mouth of Michel Creek to the Elk

The Fernie Lumber Company had one and a half million feet of lumber left in their yards from last year, but will this year make about the usual cut, all depending on the state of the water in the Elk river. If the water rises sufficiently a good crop of logs will be secured. If it does not rise high enough to float there



FERNIE LUMBER COMPANY'S SAWMILL IN THE ROCKIES, NEAR FERNIE, B. C.



FERNIE LUMBER COMPANY—CROP OF LOGS.

Company have their saw mill. The plant is situated one mile from the town, on the Crow's Nest Pass Railway, spur lines of which run into the yards. The Elk river passes through the company's premises.

Standing in front of the mill one can see the entrancing sight referred to above, the

river mouth. The valley here for nearly one hundred miles was clothed on both sides with a magnificent forest of heavy timber. On the west side of the stream it has been held by lumber companies, while the east side from Coal Creek to Sparwood belonged to the Crow's Nest Pass Coal Company, who are still lumbering for themselves.

The pioneer saw mill of the Elk Valley was erected by the firm of McLean, McDonald & Allister, all Ontario men. This mill was erected in 1898 on the site where now stands the Fernie Lumber Company's plant. Of the original mill firm only Mr. John McDonald remains in the valley, being now employed with the Fernie Lumber Company as superintendent of the planing mill.

The president of the Fernie Lumber Company is Mr. A. McDougall, and Mr. Lawrence M. Proctor is general manager. These two gentlemen are typical mountain lumbermen and have been actively associated in lumbering for many years. Mr. McDougall is an old Ottawa Valley man, hailing from Arnprior. He came to Fernie to engage in lumbering in 1896. Mr. Proctor was born in Ogdensburg, N.Y., and first went into the lumbering business twenty-three years ago. He came to Fernie, B.C., in February, 1898, and has since become a well-known figure among the Rocky Mountain lumbermen, mastering the varied details of skidding the logs from the highest peaks through the various processes of manufacture until the lumber is shipped.

will be a short crop, as also will be the case if it rises too high to carry away the bridges and dams. The pond where the logs are placed before cutting is a natural one, a small dam being sufficient to maintain a full head of water.

The saw mill is operated with a 60 inch circular saw, and maintains a steady running. It is fitted to receive, if necessary, a band mill. In the plant are edgers, trimmers, niggers, slab slashers, live rollers, lath mill,



FERNIE LUMBER COMPANY'S GANG CUTTING A TREE AT THE FOOT OF THE ROCKIES.



FERNIE LUMBER COMPANY'S PILING GROUNDS—ROCKY MOUNTAINS IN THE DISTANCE.

planing mill with three planing machines, band saws, turning lathes, rip saws, etc.

The mill site occupies about 130 acres in extent. The company have about seven thousand acres of splendid timber, composed of fir, spruce, cedar and tamarac, all being

within easy hauling distance of the mill. There is also quite a bit of cottonwood on the company's limits which they intend to cut shortly and try as an experiment for wagon and buggy box stock. This wood is called whitewood by some.

The timber is driven down the Elk river from the limits as far as is practicable, but a great deal is brought in by sleighs in winter—a road being made and a sprinkler being run all night until the first hauling team starts in the morning.

Owing to the cheapness of fuel (both wood



FERNIE LUMBER COMPANY'S PLANING MILL GANG.

and coal being abundant) hundreds of cords of slabs are burnt as waste. These slabs were sent to the prairie towns, going as far east as Moose Jaw and Regina, but it did not pay for the cost of handling.

Logging in the mountains is done by sleds where practicable, or by means of log slides built down the mountain sides. These slides are made by two rows of logs lying close together, thus OO, and from which the bark has been peeled. A third or smaller log is sometimes used, thus OOO. Between these logs the great sticks of timber come shooting down the sides of the mountains into the streams below. Where sleighs are used and the track



MR. LAWRENCE M. PROCTOR,
General Manager Fernie Lumber Company, Fernie, B. C.

becomes too slippery, men are stationed at the sides and put on sand to prevent the runners sliding too freely.

In answer to a question one of the loggers said: "The timber in the mountains is pretty well mixed, but spruce seems to be more abundant at a lower elevation than tamarac.

As a rule the fir and the tamarac grow higher up on the mountain.

Like all real practical lumbermen, both Mr. McDougall and Mr. Proctor are of the genial, sociable sort, ever ready to say a good word for a rival and always affable. In the accompanying photo of the planing mill hands the group contains ten men belonging to No. 2 rifle company of the Rocky Mountain Rangers,



MR. HAYES H. ROSS, OF ROSS BROS. & CO.

two of these being sergeants and one a corporal.

As the writer came away from this mill he passed the men's boarding house nestling snugly under the majestic brow of big Mount Fernie, a grand peak, towering away up into the clouds and always snow-clad and ice-capped at its summit.

A KOOTENAY VALLEY MILL.

The old mill site at the junction of the Elk and Kootenay rivers at Elkmouth, B.C., has been thoroughly overhauled this spring and placed among the best of the B.C. mills. This mill was formerly owned by the Elkmouth Lumber Company, who were succeeded by the young and enterprising firm of Ross Bros. & Company. It was bought from the Trites-Wood Trading Company, of Fernie, in January of this year by the Ross Brothers.

Elkmouth is situated on the line of the Great Northern Railway, near Krag, B. C. The mill was established about four years ago and has been running every year since.

The present owners, Messrs. Hales H. and Joseph W. Ross, are from Whitemouth, Manitoba, where their father, David Ross, ran a saw-mill for 26 years. The latter retired from active business five years ago and is now living at Whitemouth.

Ross Bros. & Company are now cutting about 40,000 feet per day, and will cut a total of three million feet this year. Many mills have their planers arranged in the saw-mill to dress the lumber green as it comes from the saw. The Ross Company will dry their lumber in the rough, letting it stay in pile until sufficiently dry to put through the planer. It is calculated that by this means there will be little or no shrinkage after the lumber is dressed. For dimension stuff this would not mean much, but for ship-lap, siding and flooring and for all upper grades it will be of great utility to the actual user of lumber.

The cut of the Ross mill runs about half white pine and a quarter each fir and tamarac. There is no spruce in this section of the Kootenay Valley.

Formerly there was a big loss of logs when a one-log boom was used on the Kootenay river, but the Ross Company put in a 4-log boom anchored by 3-inch hawser lines and 3/4 inch steel chains. They anchor this boom to



MR. JOSEPH W. ROSS, OF ROSS BROS. & CO.

a "deadman" sunk deep in the shore, and for the first time, it is claimed, in the history of the Kootenay river, they have not lost a log. The great loss formerly sustained was caused by the logs going under the one-log boom. Mr. H. H. Ross, the capable and genial manager, says that their mill is not affected by high or low water, as the Kootenay is never too low to drive.

The market for the Ross Company's output is principally Alberta and Assiniboia, the high



ROSS BROS. & COMPANY'S MILL AT ELKMOUTH, B. C.

grades going to Winnipeg. The company load on C.P.R. cars at Elkmouth, running same over the Great Northern Railway to Morrissey Junction.

An estimate of the timber limits held by this company places their available logs at a hundred million feet. All of this is within seven miles of the mill on the banks of the Kootenay. The haul to the river runs from 1/4 to 2 miles, which is done by sleds in winter and trucks in summer, all on a down grade road to

the river. These logs run about seven and eight to the thousand feet.

This firm are about to put in a lath machine and are also manufacturing all kinds of mouldings, interior woodwork, etc. The saw-mill has a 60-inch circular, patent 4-saw edger, two trimmers, two planers (one of the latest improved pattern), live rolls, steam feed, etc. The machinery is driven by a 125 h.p. boiler, with a 100 h.p. engine with a Russell automatic cut-off. They use a jack-ladder chain for hauling up logs from the pond. The burner is situated across the creek, 250 feet from the mill. The lumber is loaded direct by tram cars on to the main loading platform next the spur line which runs the entire length of the company's yards, the latter consisting of 600 acres of crown granted lands. The pond is one mile long and with very little improvement it can be made to hold ten million feet of logs. The whole plant is a credit to this enterprising firm.

WHY ASIATIC LABOR IS EMPLOYED IN CANADIAN SAW MILLS.

Considerable interest has been manifested in the recent trouble between the Kootenay Shingle Mill Company, Salmon, B. C., and their men. The white employees refused to work with the Orientals, and endeavored to have the latter driven out of the locality. Enquiry has been made by the CANADA LUMBERMAN, from some of the more prominent lumbermen and other employers of Asiatic labor on the Pacific coast, relative to the origin and advantage of the employment of Chinese and Japanese labor.

The original cause, it has been learned, was owing to the scarcity of sufficient cheap labor with which to carry on the rougher work of the mill. There is always a certain amount of work around a mill which is necessary in its operation, but which calls for no particular skill. In Eastern Canada there are plenty of men to be found, many of them French Canadians, who are willing to undertake work of this kind at a comparatively low wage. At the time British Columbia was being opened up, there was a scarcity of white labor. The whites that were here were needed for the work calling for more skill and brains. Consequently, there was no one to do the cheaper work without which operations would necessarily have to be suspended. This led to the employment of Chinese and Japanese, or Asiatic labor, as it is called.

Another reason for the employment of Orientals, particularly the Chinese, is the fact that they can always be depended upon to turn up at their places every day, or in event of sickness or other necessary absence, they will provide a substitute. This cannot be said for the white man. Very often, and especially after pay day, the white man gives way to the temptations that exist, more perhaps in a new country than in the older and more conservative parts where home ties and relationship are stronger, and he is off duty for two or three days or longer. Returning to his work, he is often not in fit condition to fulfill his duties. All this time the mill has

been more or less handicapped, according to the number of men that are away. This applies particularly to mills in rural districts, where labor is even scarcer than in or near the cities.

In mills where whites are employed for the rougher and cheaper work, the foremen are always in trouble owing to the tendency of the white man to "jump the job" the moment something better offers itself. In this, the white can hardly be blamed, for it is the duty of every man to try and improve his position, but on the other hand it is unfair to the foreman or manager of the mill. He goes to the mill in the morning, depending on a certain man for certain work, and learns that the man has had a better job offered him and is going to take it. The Orientals can be relied on year in and year out, no matter how common or monotonous the work may be, they are usually satisfied with their lot.

In shingle mills, Chinese packers are in many cases employed. The chief reasons for this is, first, the certainty that they will be at their post, for if the packer is not on duty the sawyer, who, by the way, is invariably a white man, cannot go on with his work, as the shingles would soon fill up and block the machine. Secondly, the Chinese can be depended upon to properly cull out the seconds, and the white is apt to let some of them go through, as it takes more time to pick them out. This, it is claimed, is one of the secrets of the popularity of B. C. shingles.

In Washington state, where Chinamen are excluded, boys are generally employed as packers. The boys, whose ages run from 21 years up, learn quickly and in many cases are making big money while still young. Receiving more money than is required for living expenses, they early learn to spend foolishly and become more or less dissipated. The result is evident in poorer work and poorer men too.

In the matter of salary, it cannot be said that Asiatic labor is keeping wages down. On the whole, Asiatic labor can be said to be better paid than most of the cheaper French Canadian laborers of the East. If the mill-owners were compelled to employ white labor only for the unskilled as well as the better class of work, at the present high standard of wages, and the present low prices paid for lumber and shingles, many of the mills now running would have to shut down, thereby throwing a large number of men out of employment. Thus it will be seen that the Orientals rather than being the cause of whites being out of work, are in a very large measure making it possible to give employment and at a higher scale of wages than would otherwise be the case.

This is the state of things as they are at present and have been in the past. This,

however, will not necessarily always continue to be the condition. With the influx of the white population, especially whole families coming into British Columbia and the increase of native born whites, together with the probable decrease of Chinese coming in owing to the higher cost of entrance to the province, it will become easier for the employer to secure white men and to hold them in the minor positions than it is now, and on the whole probably no one will be better pleased than will be the employer himself. With all the good points the Oriental may have, there is a natural fellow feeling on the part of the employer for his white brother, and he will get the preference every time, where it is at all possible. Just now, however, to put it in the words of a prominent employer of mixed labor in Vancouver, "The white man is wanted for the better work and there is room for every white man in British Columbia that has got a head on him with brains enough in it to enable him to think for himself and his employer."

Vancouver, B. C., June 14, 1905.

FORESTRY BUILDING, LEWIS & CLARK EXPOSITION.

The forestry building at the Lewis & Clark Exposition at Portland, Oregon, which opened on June 1 and will continue until October 15, is unique in design and a visual evidence of the timber resources of the Pacific Northwest. It is made entirely of logs of extraordinary

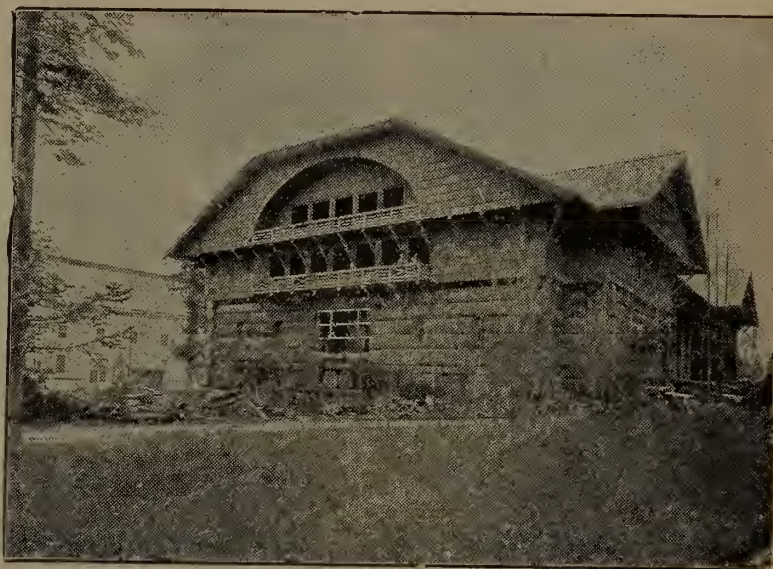

Forestry Building, Lewis & Clark Exposition, Portland, Oregon, June 1 to October 15. (Cut kindly loaned by the Northern Pacific Railroad.)

dimensions. Reduced to the reality of figures there has been two miles of five foot and six foot fir logs used in the building, eight miles of poles, and many tons of shakes and shingles. Uncommon taste has been employed in combining many rough timber features into an ensemble of rare beauty and symmetry. It is 206 feet long and 102 feet wide, and rises to a height of 72 feet.

One log stands near the main entrance which has a diameter of seven feet nine inches. It required a total of 112 horse-power with engine, block and tackle to raise the immense logs to their places. Twelve thousand feet of wire cable was used for hoisting and guys. The heaviest log weighed 35 tons, and was lifted to its place at the rate of 30 feet per minute.

THE Wood-Worker and Retailer

BARRELS WITHOUT BULGE.

"Minneapolis, which has for years manufactured more barrels than any city in the West, especially barrels for flour packing, is expected soon to have a large plant for the manufacture of the newly patented Alexe barrel, which, it is claimed, is a great improvement on the present type of barrel in many

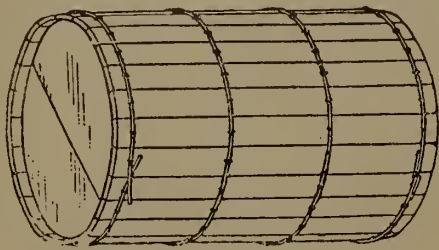

THE ALEXE CYLINDRICAL BARREL.

ways. The Alexe barrel is a straight-stave barrel, with wire bands, and its great advantage lies in the fact that it may be shipped knocked down and crated in small space, is easily put together, and when filled for shipment, will occupy less space than a bulge type barrel of the same capacity.

"The improved barrel is the invention of Frank Alexe, of Brooklyn, N.Y., who has carried his idea far beyond the experimental stage. The device is patented in the United States and Canada and in twenty-five foreign countries.

"Mr. Alexe states that his barrel is not only cheaper and more convenient, but that it is far stronger. The timber is kiln-dried and is not weakened by the bending process. As the staves are flat, they may be worked into shape from the raw material with less work and by less expert help than is required for the old-style barrel. Practically every step in the construction may be done by machinery. The staves and heads are packed in bales and ship in much more compact form than the old-style barrel. The bulge of the old barrel was necessary in order to drive the hoops tight. With the Alexe barrel, the hoops are of wire drawn perfectly tight and held in place by staples. The patents cover also a forming machine for setting up the finished package, an operation so simple that it may be done by ordinary labor.

The finished barrel is tight and does not require lining to prevent leaking. The bulge of the old barrel prevented close packing in shipping and caused damage from loosened cargoes, but the new cylindrical barrel will pack tight and close.

"A heavily capitalized company will begin manufacturing these barrels. Six factories will

be established, two in Canada and the others in the United States."

A THRIVING VANCOUVER INDUSTRY.

One of the neatest and most up-to-date little planing mills on the Pacific Coast is that of H. J. Fortin on Ninth Avenue, Vancouver. Mr. Fortin, began business four years ago with an outfit worth hardly more than one hundred dollars, but since then he has been steadily increasing his plant. Recently he has erected a large building adjoining the old one at the rear but in size much larger. He has now a floor area of 7,500 square feet. The building is so situated that the rise of the hill at the rear and the high street level in front makes it possible to have a level entrance right into the mill on either the ground floor or the second floor.

The ground, or first floor, is used mainly for finishing purposes and as an assembly room. It is equipped with a sandpaper machine, mitre machine and other tools used in the finishing process. The second floor contains

made by the Canadian General Electric Company. One is a 10 h.p. two-phase 250 volt alternating current machine and the other an 8 h.p. 2-phase, 500 volt direct current.

Mr. Fortin manufactures sash, doors, windows, mouldings, trimmings and general interior house finish.

IMPROVED VARIETY SAW.

An improved variety saw with boring attachment, M 197, as manufactured by Cowan & Company of Galt, Limited, Galt, Ont., is represented by the accompanying illustration. This machine is capable of doing a great variety of work in the very best manner, and is particularly suited for jobbing shops. The frame is in box form, cast in one piece, with broad flange base and rigid slide ways for the table bracket or yoke. The table is of iron, raises and lowers 5" on gibbed ways by means of screw and hand wheel, tilts to angle of 45 degrees, and has adjustable mitre gauge which may be used on either side of the saw. Jointing, dadoing, rabbeting or grooving heads may be used by means of a large detachable throat plate surrounding the saw. The table surface is 36" x 44" and material 20" wide may be slit; an 8" saw projects 1½" above the table, and 15" saws may be used.



IMPROVED VARIETY SAW MANUFACTURED BY COWAN & COMPANY, GALT, ONT.

the most of the machinery. The equipment includes band saw, rip, and cutoff saws, mortiser, tenoner, stickers, two planers and two lathes. The third floor is used for getting out the material, ripping, dressing, etc. Two planers, a surfacer, a rip saw and a cut off saw are part of this floor's equipment.

Power is obtained from two electric motors

The boring attachment consists of heavy slideways rigidly secured to the frame upon which a strongly braced table bracket is gibbed; the table slide is gibbed in turn to ways on top of the bracket with provision on both sides for taking up wear.

A wood table and bar as shown in the illustration are usually supplied, but iron table can be substituted if desired. All the fitting is first class and the parts adjusted very exact so that fine jointing may be done

FOR THE CAMP

We have a very suitable lot of goods for camp supplies. We make this kind of trade a specialty. You who are not getting suited just as well as you would like, try us for your next order, and give us a chance to demonstrate our ability to give you satisfaction in this very important department of your business.

H. P. ECKARDT & CO.

Wholesale Grocers

TORONTO

on the saw and accurate boring with the bit. A plain bit socket is sent with $\frac{1}{2}$ " hole, or Morse taper hole as desired. The countershaft is usually attached to the floor 4 feet or 5 feet from the machine, but it may be placed below floor if desired. Further particulars of of this or other first-class wood-working machinery will be furnished by the manufacturers upon request.

AMERICAN NO. 5 DOUBLE DOOR STICKER.

This machine is designed for sticking stiles and rails

in the rail is received by the adjustable table placed on the main bed directly back of the under head. This gives a perfect surface and bearing while the top head is cutting. The extra table can be removed when the under head is used for jointing. This feature alone makes the machine most valuable to door manufacturers, as this is claimed to be the only practical way to work the top and bottom of a rail or stile successfully at one operation.

The top and bottom heads have lateral adjustment,

SAPPY STOCK FOR LATH.

A writer in the Mississippi Valley Lumberman says:—"I don't suppose you could get the people to believe it, but I believe that the best use that sappy wood can be put to is to make lath out of it. Coming in contact as they do with lime, which is one of the best known preservatives of wood or anything else, their tendency to rot would be checked, and their strength would be thus unimpaired for that purpose. If they are thoroughly seasoned when put on, there is not much likelihood of

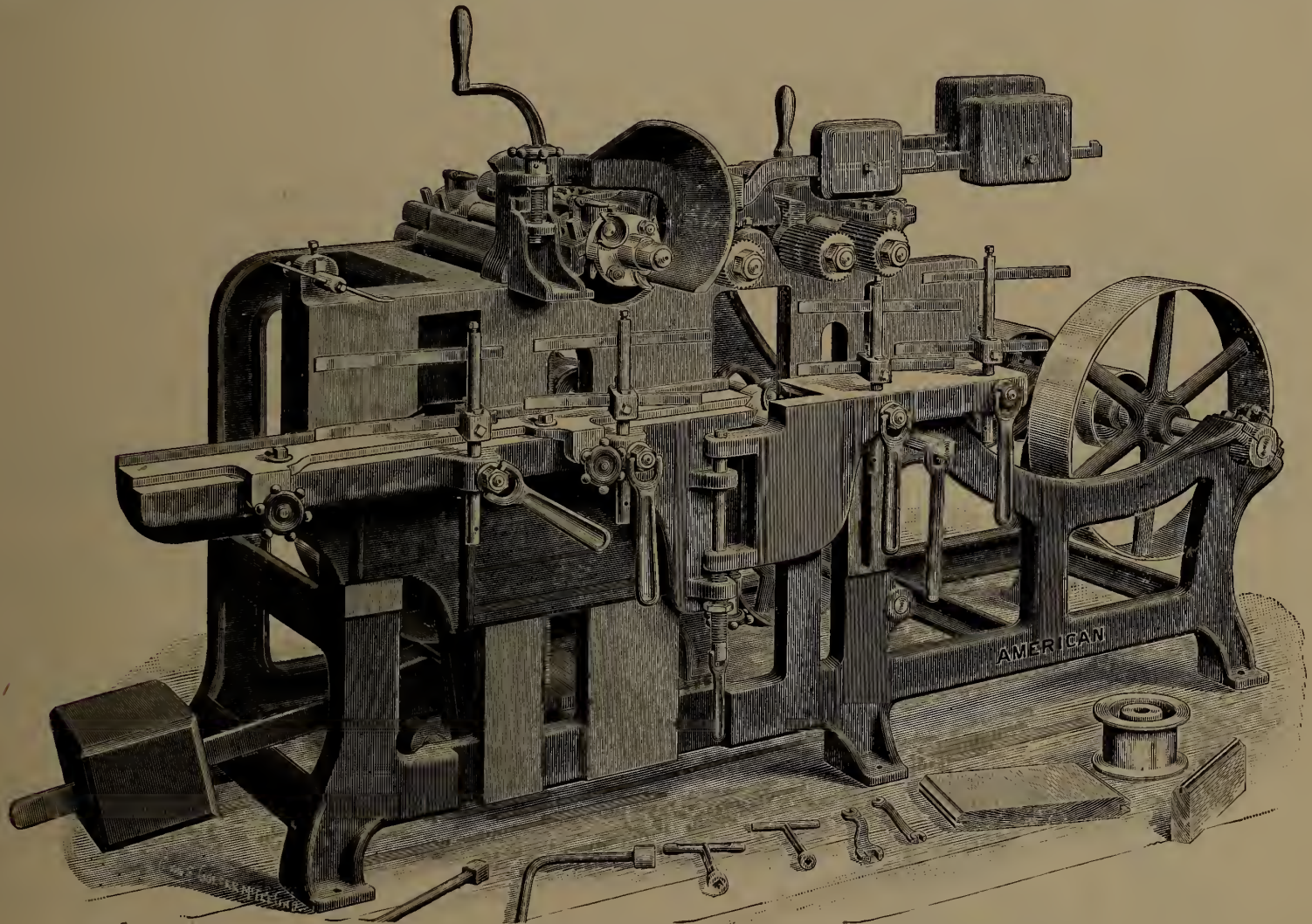

AMERICAN NO. 5 DOUBLE DOOR STICKER, MANUFACTURED BY THE AMERICAN WOODWORKING MACHINERY COMPANY, NEW YORK.

for doors and sash, working both edges of door rails and stiles, sash bars and muntings, or working one edge and joining the other at one operation. The frame is cast in one piece, well braced, rigidly supporting all working parts. The table is gibbed to the frame, the gib extending the whole depth of the table. It is raised or lowered $1\frac{1}{2}$ " by the crank at the top of the machine. The front part of the table is so arranged that it can be swung out of the way of the under cutter-head, giving the operator free access to the head. The feed consists of three 3" feed rolls, weighted and driven by a powerful system of gearing.

The lower head is placed in front, thus working the bottom part of the rail or stile first. The groove mad-

and a groove can be run in the center of any thickness. The bottom head has lateral and vertical adjustments. The hood and chip breaker are adjustable to and from the top cutter-head. There is a binder to stop and start the feed within easy reach of the operator.

Information concerning this or other wood working machinery, may be obtained from the American Wood Working Machinery Company, 136 Liberty street, New York.

M. I. Ryan, bookkeeper at the head office of the Elk Lumber Company at Fernie, B.C., has resigned and has been succeeded by J. S. Volume.

their staining the walls. I never did take much stock in the old theory of lath staining the plastering. If it ever does, it is on account of putting them on green, and their being unable to absorb the water from the mortar. The stain from the sap will come through unless it is dried very quickly.

I never see a lot of No. 1 white pine lath but that I think it a waste of good material to put it to such use. The generations of people to come will learn economy in the use of lumber that we don't even dream of now. The whole history of the lumber business, both in its manufacture and using, is one long story of wasteful methods, and ignorance in the use of it to advantage and economy."

TRADE NOTES.

The Victoria Machinery Depot Company, Victoria, B. C., recently installed two boilers in the plant of the Western Fuel Company at Nanaimo.

The Western Oil & Supply Company, Vancouver, B. C., have recently installed a Brown & Boggs machine for the manufacture of galvanized iron shingle bands.

I. N. Kendall, of Ottawa, is installing a variable gang circular in the mill of J. Lumsden at Lumsden's Mills Que. It is expected to be in operation by August 1st.

Graham & McCormack, of Pembroke, Ont., are doing a very large business in lumbermen's moccasins and mitts. They have enlarged their factory and are in a position to fill all orders promptly.

Alex. Barr, of Pembroke, Ont., intends enlarging his work shops by another building 100 x 40 feet. This building will be constructed of cement blocks and will be fireproof. His business in lumbermen's sleighs, waggons and dump carts has become very large, although he has owned the business for only two years.

A new metal called "Emett's Hardite" now has a place on the market, and fills a long felt want amongst loggers, miners, smelters, quarry owners and users of a hard tough metal. We understand that there is quite a demand already for it in British Columbia, where logging is carried on to a great extent, and where sheaves wear out in a few days. Emett's Hardite sheaves will out-wear quite a number of the old soft iron sheaves and saves the wire rope, as well as prolonging the life of a pulley. Ground rollers and tree rollers

are in the same category. Mr. G. H. H. Emett, of New Westminster, B. C., is the inventor.

The Manitoba Gypsum Company, Winnipeg, manufacturers of hard wall plaster, have got well started on their spring output, having brought down their first cargo from their Lake Manitoba mill about the middle of May. The demand for hard wall plaster this season is extremely good, and the cargoes are being shipped out from Westbourne as fast as they come in. A wood fibre plant is now being installed, and this latest development of the plaster industry will be on the market this month. Wood fibre plaster has many advantages over ordinary hard wall plaster, one of the principal being the fact that sand is not necessary in making the plaster ready for application to the wall, the wood fibre doing away with this, and making besides a much harder and tougher wall. The Manitoba Gypsum Company have had printed some very full information on hard wall plaster and wood fibre plaster, which they will be glad to send to anyone making application.

A NEW EDGER.

Messrs. B. R. Mowry & Sons, of Gravenhurst, Ont., are turning out some very fine machinery. They have lately sold to Messrs. George Chew & Son, of Midland, one of their well-known gang edgers. The mandrel will take from ten to fourteen 26 inch saws. The side for edging boards feeds about 300 feet per minute, while the side for ripping up the cants feeds about 70 feet per minute. The mandrel on this edger is 4½ inches in diameter by 10 feet 8 inches long. An improvement is attached to this machine making it

impossible for the cant to fly back, but the operator can reverse the feed by touching a lever in case the saws bind. Messrs. Chew & Sons are well pleased with their machine, as it makes a great saving of time where any quantity of small logs are to be cut, as a light slab taken off two sides of the log and then run through the gang edger and ripped up into boards will save a lot of labor for the carriage. Messrs. Mowry & Sons are having a number of enquiries about this machine and expect quite a number of sales. Any one visiting Midland should be sure and see this edger in operation.

G. E. Anderson, of Douglas, Ont., has been given a contract by McLachlin Bros., of Arnprior, to raise about 4,000 logs from the bottom of Mud lake. McLachlin Bros. purpose building a saw mill at the lake to saw the logs.

The town of Atlin, in northern British Columbia, was visited by a disastrous fire on May 29th in which several business firms were burned out, including the yards and mill of the Northern Lumber Company, which were totally destroyed.

C. H. VOGEL

A. M. Can. Soc. C.E.
OTTAWA, CAN. ENGINEER
Surveys, Plans, Specifications and Supervision
WATER POWER
Paper, Pulp and Sulphite Fibre Mills



THE MOORE ROTARY PULP SCREEN

TAKES UP A MINIMUM OF FLOOR SPACE.
REQUIRES ONLY 5 H. P. TO RUN IT.
CAPACITY EQUAL TO FIVE DIAPHRAGM SCREENS.
We Invite Enquiries from Pulp Mills.

THE JENCKES MACHINE CO., LIMITED
Sherbrooke, Que.

"Doble" Tangential Water Wheels

AWARDED THE GRAND PRIZE AT ST. LOUIS WORLD'S FAIR



Tangential Water Wheels have been developed to meet the demand for large units of highest economy, close regulation and absolute reliability in service.

The John McDougall Caledonian
Iron Works Co., Limited
MONTREAL

Builders for Canada

Catalogue on Application

CAR MOVERS.

Car movers are a necessity by any firm receiving and shipping car load lots of lumber. The switch engine may place a car near where it is wanted, but if it has to be moved to a more convenient location, that duty devolves upon the shipper or receiver. To facilitate the moving of loaded cars, the Giant Car Mover has been invented.

The Giant Car Mover has a sliding wedge which holds what the lever gains, this being very important when a car is to be moved up grade.

The Giant Car Mover is sold direct to the consumer from the manufacturer at the low price of \$3 each, with a guarantee from the manufacturers that they will replace free of charge any malleable part broken

in ordinary use within six months from date of invoice.

The M. Mitshkun Company, Detroit, Mich., own the patent and are the manufacturers of this valuable car mover. They have received numerous unsolicited testimonials from prominent and responsible users endorsing the "Giant" as the best and most practical car mover on the market. Full particulars of this and other specialties can be had by writing to them for their monthly publication, "The Railway Equipper," which is mailed free of charge to all who desire to keep posted on railway equipment.

M. J. Shea, of Vinton, Que., met with a horrible death while working in Kelly's saw mill at Bryson.

He fell against the circular saw, his head and arm being almost completely cut off.

Lester David has purchased from the city of New Westminster, B.C., a portion of the machinery in the old electric lighting plant. It will be installed in the mills of the Fraser River Saw Mills Company at Millside, which are soon to be put in operation. The machinery purchased includes a large dynamo, Corliss engine, fan draught, two boilers, pumps and shafting and a quantity of belting.

P. PAYETTE & CO.

Manufacturers of Saw Mill and Engine Machinery, and all kinds of Marine Machinery.

PENETANGHISHENE, ONT.



These Mules Cannot Break This Yarn

BECAUSE IT WAS MADE BY THE

Consumers Cordage Co., Limited



Poor Yarn is Dear at Any Price

We Manufacture

**Double and Single Lath Yarn,
Shingle Yarn, and Cordage**

Of Every Description

Our mills are equipped with the latest improved machinery for making extra long lengths of Transmission Rope.

CONSUMERS CORDAGE CO., LIMITED

Montreal and Halifax

**New Sawmill Machinery
FOR SALE**



- One No. 1 Lane Mill R. H. Wood Frame. 16 ft. Carriage, Rope Feed, New.
- One No. O Lane Mill R. H. Wood Frame. 24 ft. Carriage Rack and Pinion Feed, New.
- One No. O Lane Mill R. H. Wood Frame. 25 ft. Carriage Rack and Pinion Feed, New.
- One 50 in. Circular Rip Saw, Shurley-Dietrich, New.
- One 2 Saw Trimmer, New.
- One Lockport Shingle and Heading Machine, New.
- One Double Edger, 3 Saw complete with End Tables, New.

MISCELLANEOUS

- 15000 ft. Sprocket Chain, all styles.
- 3000 ft. Manilla Transmission Rope.
- 5000 ft. Rubber Belting.
- A Large Stock of Pipe and Boiler Tubes.
- Wood and Iron Pulleys, Pillow Boxes, Hangers.

The above Machines are all new and are offered at prices that must compel attention.

The Manitoba Iron Works Co.

LIMITED

Logan Ave. W., WINNIPEG

THE LUMBER MUTUAL FIRE INSURANCE COMPANY

BOSTON, MASS.

STRENGTH

NET ASSETS, MARCH 31, 1904

\$669,696.69

ECONOMY

DIVIDENDS TO POLICY HOLDERS

33 $\frac{1}{3}$ %

MAIL EXPIRING POLICIES WITH YOUR ORDER.

MODERN BOX FACTORIES.

In looking over the modernized box factory we find manufacturers have changed their methods materially, says Barrel and Box. The old slipshod way of delivering a truck load of lumber to the factory without keeping any track of it, and then making up such orders as may be in hand, has all passed. You see the foreman marching through the factory and watching every man who is handling lumber. He keeps his eye on the waste box. If he sees a piece that should not be there he wants to know the reason why. This is a necessity because lumber costs money nowadays. Labor is pretty high, too, and when you add these two items to your waste account and then figure on your general expenses and profits you will find that any shave in prices, and there may have been some shaves, means a loss of profit. The man who is satisfied to go on without improving his factory or operating on the improved method, which includes systematic handling of orders in the offices as

well, is liable to come out at the small end of the horn this year.

PUBLICATIONS.

Kindly mention the CANADA LUMBERMAN when writing for any of the catalogues referred to below.

A new price list is being furnished to the trade by the Dominion Wire Rope Company, 286 St. James street, Montreal. It is worth having.

We are indebted to Mr. W. C. J. Hall, of the Department of Lands, Forests and Fisheries, Quebec, for a booklet descriptive of the Laurentides National Park.

Bulletin No. 5, from the Smart-Turner Machine Company, of Hamilton, Ont., refers to their several lines of pumping machinery, and a copy may be had for the asking.

The Crescent Machine Company, of Letonia, Ohio, are distributing their latest catalogue of band saws and general woodworking machinery. They are bringing out some new machines which will be shown in their next catalogue. They report that the volume of business in their regular lines has materially increased during the past year.

The tenth annual report of the Chief Fire Warden of Minnesota, recently to hand, contains, like previous reports, much general information on forestry. Accord-

ing to the reports of the fire wardens, the damage done by forest fires in the state during the year was only \$21,670, and by prairie fires \$8,305. Some very interesting information is given concerning the operations of European state forests.

The second number of the "Canadian Forestry Journal," the official organ of the Canadian Forestry Association, is even more interesting than the first number. It contains reports of the annual meeting of the Association and of the American Forestry Congress, and special articles on "Forestry in Relation to Mining," by Prof. C. J. Gwillim, Queen's University; "The Forests of the Yukon," by J. Keele, of the Dominion Geological Survey, and "The Care of Street Trees," by D. Craig, of the Dominion Forestry Bureau.

We know of no catalogue which should be of greater interest to lumbermen than that issued by the Clyde Iron Works, of Duluth, and referring to the McGiffert steam log loader. It is a loader, locomotive and skidder combined and has handled 160,000 feet in a day. The manufacturers claim that logs from a distance up to 1,000 feet or more may be economically skidded, and mention an instance where a log scaling 2,000 feet was skidded a distance of 500 feet over rough ground and loaded on a car in fifteen minutes, a proceeding that would have required a team and several men five or six hours.

ELECTRICITY

If you desire to keep posted on the wonderful progress that is taking place in the use of electricity for an almost endless variety of purposes, you should subscribe to the

Canadian Electrical News
and Engineering Journal

A 44 PAGE MONTHLY,
PRICE \$1 PER YEAR

Write for free sample copy to

The G. H. Mortimer Publishing Co.
LIMITED
Toronto - Montreal - Winnipeg



Steel Frame

Dry Kiln Trucks

*Plain or Roller
Bearing Wheels*

Steel Frame Lumber Trucks

WRITE FOR BLUE PRINTS

MONTEITH, NIXON & CO.

Makers of Good Trucks

256 Macdonell Ave. - TORONTO

GIANT CAR MOVER

SEE THAT SLIDING WEDGE
IT BLOCKS THE WHEEL



M'n'f'urers Price

\$3.00
EACH

B. & R. Patent

Thousands of Testimonials.

See "THE RAILWAY EQUIPPER"
Our Monthly Publication. Mailed Free

M. MITSHKUN CO. DETROIT, MICH.

Larrigans - Leggins - Horse Collars

All manufactured by ourselves from leather tanned by ourselves.

Eminently suited to the LUMBER Trade

IF INTERESTED WRITE

THE R. M. BEAL LEATHER CO., LIMITED - LINDSAY, ONT.

Tanners of the Celebrated English Oak Harness Leather

PAROID ROOFING

FOR THE

PANAMA CANAL

The first proposals issued by the Isthmian Canal Commission called for Paroid Roofing, or equal, and the order was placed with us.

The U. S. Government again recognizes the standard qualities of Paroid, having used many carloads in this country, Cuba and the Philippines.

If you believe in quality, get our samples and booklet.

F. W. BIRD & SON, MAKERS,

HAMILTON, ONT.

Established in U. S. A. in 1817.

Lumber Insurers General Agency

66 Broadway, NEW YORK

managers of the leading insurance companies specializing in lumber and woodworking risks.

By confining our insurance business exclusively to one class of property, and by doing business direct with our policy-holders, savings are effected in losses and expenses, thus permitting a low basis of rates.

Policies of the following companies are offered.

Lumber Insurance Company of New York

Capital and Surplus \$300,000

Assets Jan. 1, 1905 \$364,525.34

Lumber Underwriters

Assets Jan. 1, 1905 \$141,173.03

Full information and application blanks on request.

THE NEWS

ONTARIO.

—W. P. Polton is advertising for sale his saw and flour mills at Waldemar, Ont.

—The Standard Lumber Company are establishing a wood alcohol plant at South River, Ont.

—The handle factory of W. C. Crawford at Tilbury, Ont., was destroyed by fire on June 2nd.

—It is reported that the Ottawa Lumber Company will shortly erect a planing mill at Hurdman's Bridge.

—W. R. Wilson, of Kenora, Ont., has purchased a portable saw mill which he will operate on Rideout Bay.

—The Victoria Harbor Lumber Company, Victoria Harbor, Ont., have installed a new planer and boring machine.

—Reid Bros. have built a barrel and cheese box mill at Picton, Ont. They expect to turn out 30,000 apple barrels this season.

—Hiram Walker & Sons, distillers, Walkerville, Ont., are building a new cooper shop which will cost upwards of \$26,000.

—It is expected that the new saw mill of the Carney Lumber Company at Owen Sound, Ont., will be in operation this month.

—S. E. White, of S. E. White & Company, saw mill owners, Lakefield, Ont., committed suicide recently. No cause is known for his action.

—Mason's sash and door factory at Hintonburg, Ont., was destroyed by fire recently, the origin of which was lightning. The loss was \$10,000.

—The Imperial Lumber Company and Salmon & Company are building new saw mills at Latchford, Ont., which will be in operation this fall.

—The Lieutenant-Governor has issued an order-in-council revoking the license to do business in the province of Ontario issued to the Poulin Lumber Company, Limited.

—E. T. Richardson, formerly of Little Current, Ont., has purchased a half interest in a large saw mill at Emo, Ont. The business will be carried on under the name of Alexander & Richardson.

—The Cockburn Lumber Company, of Sturgeon Falls, Ont., who recently lost their saw mill at that place by fire, have a mill west of Lake Nipissing for the manufacture of broom handles.

—George A. Mason has decided to immediately rebuild his planing mill at Hintonburg, Ont., which was destroyed by fire last month. The mill will be over 100 feet long and will be equipped with modern machinery.

—A boiler in Bonnell Bros.' saw mill at Hoath Head, about eight miles from Owen Sound, Ont., exploded last month and completely wrecked the engine house. The crown sheet was blown out and the boiler thrown 60 feet. No one was injured.

—The barrel and stave factory to be built in connection with the new mill of the Ogilvie Mills Company, at Fort William, Ont., will be 50 x 85 feet and five stories high. The construction will be under the supervision of Mr. Chalfant, the company's millwright.

—The Dymont-Baker Lumber Company, who recently lost their mill by fire, have decided not to leave London, as was reported. They do not intend rebuilding at present, but have secured additional property for the purpose of extending their lumber yard. A mill may be built later.

—The Riverside Lumber Company, Limited, has been incorporated to acquire the business of John Whiteside at Huntsville, Ont. Mr. Whiteside is one of the principal stockholders in the new concern, and associated with him are Charles Dinsmore, Alex. Bonser and William Thompson. It is probable that a new mill will be built on the Whiteside estate.

—The Bryan Manufacturing Company, Limited, Collingwood, Ont., has been incorporated, with a capital of \$150,000, to acquire the planing mill and box manufacturing business of the Bryan Manufacturing Company and to carry on a general wholesale and retail lumber business. The provisional directors are F. W. Bryan, W. H. Bryan and W. T. Herrington.

—The Manning Wood Fibre Company, Limited, has been incorporated by the Ontario Government, with a capital stock of \$100,000. It is proposed to establish a factory at Peterboro. Mr. Manning, the promoter, has invented a new machine for the manufacture of excelsior. It will take a block 8½ inches wide and 25 inches long. Others interested in the company are Thomas Porter, of Embro; J. S. Brown, of London, Ont.; David Hogg, of Perth; and John A. Irwin, of Campbellford.

THE EASTERN PROVINCES.

—E. C. Laverdure is building a planing mill at Janeville, Que.

—The dissolution is announced of T. Prefontaine & Company, lumber dealers, Montreal.

—The Drummond Lumber Company, Daveluyville, Que., are offering their business for sale.

—W. J. Moses is building a mill at Farrelton, Que., for the manufacture of cheese box veneer.

—Rhodes, Curry & Company, of Amherst, N. S., recently received an order from Bethsada, South Africa, for the interior finish of a church.

—A. Burgess, of Burgess & Sons, saw millers, Grand Falls, N.B., was recently struck by a log bouncing off the carrying table in the mill. The accident, although painful, is not considered serious.

—Twenty-two lumber camps near Charlevoix, Que., were recently burned by a forest fire. They were the

property of the Laferriere Lumber Company and of Mr. Anders, M. P. Eighty woodsmen escaped with difficulty.

—The Union Bag & Paper Company, of New York, have bought out the Charlemagne Lumber Company, of Montreal, the transaction including the limits and mills. The purchasers have mills in various parts of the New England States and will export a large quantity of pulp wood from the limits.

—Early in June a forest fire occurred on the Alexander Gibson Railway & Manufacturing Company's limits near Blackville, N.B. The mills were closed down and the crews sent to the woods to give all possible assistance, with the result that the fire was conquered before heavy loss had been sustained.

—T. E. Babbitt & Son have about completed arrangements to re-engage in the mill business at St. Mary's, N.B. They have secured the river bank property above the highway bridge as well as the property situated below the Indian reserve and will erect a new mill, which may include a sash and door factory. A short time ago Babbitt & Son sold their business to the York & Sunbury Milling Company, who are now operating the mills at Gibson.

—The International Paper Company are reported to have purchased the timber limits and saw mill properties of the William Richards Company, of Chatham, N. B. The company had an option on the properties for an amount in the vicinity of \$600,000 and it is reported that the option was exercised before its expiration on June 15th. The limits include about 166,000 acres, of which 115,000 acres are on the Taxis River. The intention of the International Paper Company is said to be to build a modern saw mill immediately and extensive pulp and paper mills a few years later.

MANITOBA AND THE TERRITORIES.

—J. J. Stevenson has opened a lumber yard at Tyndal, N.W.T.

—Maltby & Cook have opened a lumber yard at Manor, N. W. T.

—Mr. Ireland has completed a new sash and door factory at Virden, Man.

—R. R. King has sold his lumber business at Melfort, N.W.T., to Nesbitt Bros.

—Jacob Scott, lumber dealer, Stonewall, Man., has admitted John A. Stratton as a partner.

—James McEwan & Company, who recently established a lumber yard at Arcola, N.W.T., are doing a very satisfactory trade.

—McEachren & Cummings, lumber, etc., Brandon, Man., have been succeeded by the Western Canada Lumber & Fuel Company, Limited.

TENTS

That are the acme of perfection, in all details of work. BRITISH ROYAL NAVY method of cut, workmanship and finish. MATERIAL used made in SCOTLAND by the Navy Contractors. Samples and prices are mailed on request.

TOBIN TENT & AWNING CO. OF OTTAWA Long Distance phone No. 432

CRAIG MINE CRYSTAL CORUNDUM WHEELS

Our Pure Crystal Corundum Saw Gummars have no equal for their Rapid, Cool, Cutting Properties.



Read the following from Bulletin 180 of the United States Geological Survey, which says:

"Often a distinction is made between emery and corundum, many persons not recognizing emery as a variety of corundum.

Emery is a mechanical admixture of corundum and magnetite or hematite. It is, of course, the presence of corundum in the emery that gives to it its abrasive qualities and makes it of commercial value, and the abrasive efficiency of emeries varies according to the percentage of corundum they contain."

Emery is imported, mined by Greeks and Turks and contains only about 25% corundum. Our Crystal Corundum is guaranteed to be 98% pure alumina, a Canadian product, mined and manufactured by Canadians for Canadians.

HART CORUNDUM WHEEL COMPANY, Limited, Hamilton, Ont, Can.

—The Union Supply Company have sold their lumber business at Hague, N. W. T., to J. A. Ross.

—The Menz Lumber Company, Winnipeg, Man., have been succeeded by the Foss Lumber Company.

—The Royal Lumber & Fuel Company was recently formed in Winnipeg and is already doing a large business. The officers are: President, A. M. Stewart; vice-president and manager, J. E. Gaudin; assistant manager, R. E. Blakeway; secretary, G. A. Metcalfe. Mr. Gaudin, the manager, is also interested in the Gaudin-Dewitt Company, which is doing a prosperous lumber business at Napinka, Man.

BRITISH COLUMBIA.

—Moore & Whittington, of Victoria, B.C., have the contract to supply the wooden block pavement for that city this year.

—The Taylor-Pattison Mill Company, Limited, a British Columbia concern, has been incorporated, with a capital of \$50,000.

—The Penticton Lumber Syndicate, Limited, has been incorporated by the British Columbia Government, with a capital of \$10,000.

—Edwin Loder was killed by the falling of a tree while working for the Revelstoke Lumber Company on the Jordan river, B.C.

—The name of the Export Lumber Company, Limited, Mayook, B. C., has been changed to the Mayook Lumber Company, Limited.

—E. Simpson & Company have disposed of their lumber business at Moose Jaw, N.W.T., to the Porto Rico Lumber Company, of Nelson, B.C.

—A. C. Hatch, sash and door manufacturer, Vancouver, has put in a system of piping and fans for carrying away the cuttings and shavings.

—E. L. Kinman has given notice of his intention to improve the Three Valley creek and Fog creek, both in Yale district, B. C., for logging purposes.

—A. Cotton, shingle manufacturer, of Vancouver, has in his office a novelty in the shape of a perfect shingle measuring exactly 2 1/3 inches wide.

—Cooke & Tait, Vancouver, contemplate installing a new boiler and engine of about 125 horse power. They also intend erecting another dry kiln immediately.

—G. Stone, foreman for the Dickson Company, of Peterboro, Ont., made a record this spring in bringing a drive of logs from Buckhorn to Lakefeld, the time being nine days.

—The planing mill of the Hanbury Manufacturing Company at Elko, B. C., has been completed. J. M. Agnew, of the North Star Lumber Company, has been appointed manager.

—The British Columbia Government has recently granted incorporation to the Sovereign Lumber Company, Limited, with a capital of \$100,000. A general saw-milling business is proposed.

—The Alberta Lumber Company, located on False Creek, Vancouver, have recently installed some new machinery, including a new planer and carriage. Their present daily output is about 40,000 feet.

—Robertson & Hackett, saw and planing mill men, Vancouver, have just replaced their old boilers by three new ones made by N. Thompson & Company, of that city. The new boilers are each about 100 h. p.

—The Fraser River Tannery Company, Limited, have decided to proceed at once with the erection of a tannery at New Westminster, B.C. It is estimated that it will require upwards of 1,000 cords of bark for this season's work.

—The West Coast Lumber Company, Limited, of British Columbia, have recently removed into new offices in the Holland Block, 318 Hastings St., Vancouver. The president of this company is Dr. Spencer, the secretary being Mr. H. G. Ross.

—The Pierce-Pement Logging Company, Limited, incorporated in British Columbia last month, with a capital of \$25,000, will take over the logging business now carried on by Charles Pierce and John Pement and will carry out an agreement with Joseph Buch, of Blaine, Wash.

—A report has been received from Vernon, B.C., of the amalgamation of the Trepanier Saw Mill Company's mill, H. McDougall & Company's mill and store and W. A. Lang's general store. The businesses will be operated under the name of the Peachland Trading Company, with W. A. Lang as manager.

—James Leigh & Sons, Victoria, have been making extensive improvements to their mill. A new rollway and a new slip have been put in, and they have added a Waterous four-saw gang edger and a new trimmer. In the factory they have installed a new 40-inch three drum sander of the McGregor Gourlay make, an Egan double saw table and a Cowan cut-off saw and shaper. They intend still further improving their plant by the erection of a new dry kiln.

—The mill of the Fernie Manufacturing Company, Fernie, B. C., was destroyed by fire on June 7th. The factory was built about two years ago to manufacture sash, doors and house finishings, but becoming financially embarrassed was taken over by the Union Bank of McLeod. For many months it has not been in operation. The property was about to be sold to F. H. Hale, of Enderby, and was to be operated in conjunction with the Cedar Valley Lumber Company's mill. The loss is about \$30,000, which is less than half covered by insurance.

—C. M. Holbrook, of Wyoming, has taken the preliminary steps towards the establishment of an industry at Victoria, B.C., for the production of resin, turpentine and other by-products from the native fir of that province. The machinery for the plant is now being manufactured by the Victoria Machinery Depot. It is stated that the process to be employed has been thoroughly tested and has been found to give splen-

did results. The native fir, of which there is an unlimited supply, is rich in resinous and other valuable substances. The success of the industry will be watched with much interest by British Columbia lumbermen.

—Another new lumber mill is to be erected on False Creek, Vancouver, during the summer. The gentlemen who bought the old Vancouver Lumber Company, and who have been busy building a large planing mill adjoining, have decided to go still further and build an entirely new saw mill. The new mill, which it is hoped will be in operation in less than three months, will have a daily capacity of 175,000 feet. The old mill, which is at present cutting 75,000 feet of lumber per day, will then be torn down. The new planing mill of the company is now completed and the machinery in place. The dry kilns and the large sheds for dressed lumber, capable of holding 2,000,000 feet, are also completed. J. D. Moody is the manager of the company.

—A company is being formed at Vancouver, B.C., to engage in the towing of rafts of logs from British Columbia to Japan. The tow, a distance of approximately 4,500 miles in an open sea, would be the longest in the world for timber rafts. The longest tows to date have been from the Columbia River, B. C., to San Francisco, and several rafts have been broken up and lost in rough weather on that route. It is reported that W. Nightingale, of the Woodward Department Stores, will be manager of the company, and that J. G. Woods, of Woods & Spicer, shingle manufacturers, will be one of the directors. According to report it is the intention of the company to make up within thirty days a test raft of not less than 10,000,000 feet of piling and spars and send it across the Pacific Ocean in tow of a powerful tug to be accompanied by a collier. It is also proposed to engage in the saw-milling business in British Columbia.

—Lester W. David, president of the Fraser River Saw-Mills Company, made the statement early in June that the mill on the Fraser river known as the Ross McLaren mill would be running within 60 days. W. P. Fowle, late of the Bellingham Bay Improvement Company, but now superintendent of the Fraser River Saw-Mills Company's plant, had already commenced the work of getting the machinery of the mill into shape. Considerable new machinery will be installed, including a double cutting band saw, and when completed the mill will have a capacity of 280,000 feet in ten hours. It is also proposed to build a large planing mill, to be operated by electricity, and a shingle mill may also be added. The directors of the Fraser River Saw-Mills Company, Limited, are as follows: Lester W. David, president; E. J. Dodge, of San Francisco, first vice-president; W. P. Fowle, of Bellingham, second vice-president; Ernest Walker, of New Westminster, secretary; George A. Innes, of San Francisco, treasurer; Henry J. Crocker, of San Francisco, and C. J. Blake, of Anacortes.

RAILS and TRACK SUPPLIES

NEW and Re-laying from 12 to 60 lbs. per yard with fastenings; for Lumbering, Mining and Contracting Work. Immediate shipment from Stock. Get our prices before purchasing.

SESSENWEIN BROS.,
101 Shannon Street, Montreal

CONSULT YOUR FILER



Hanchett Saw Shaper

about that new swage or Swage shaper you are going to buy, if he has never used the Hanchett Tools, just drop us a line and we will make you acquainted with their superior points. Sent to responsible parties on approval. You run no risk when you purchase Hanchett Tools. They have stood the test of years. They are standard make. Write to us about them.



Hanchett Circular Saw Swage

HANCHETT SWAGE WORKS, BIG RAPIDS, MICH., U.S.A.
Hanchett Swages Do Good Work

TAKE A MOMENT

and note what a few users say:

FOR HARDWOODS

Our 48-inch Columbia Sander has proven very satisfactory. We find the machine does all we expect of it, and are particularly pleased with the work it does on our hardwoods. We would be very glad to recommend the sander to any one desiring to use it for doors, sash and hardwoods of any kind.



WE MADE NO MISTAKE

We looked the market over carefully before buying to get the best machine, and decided on the Columbia. We made no mistake. We sandpaper 48 doors 3 x 8 feet in one hour and do first-class work. The machine is all you guaranteed it to be. The workmanship is first class and the adjustments are the best on the market to-day, especially your automatic paper-fastener. We do not know how you can make the machine any better.

WE LOOKED THE MARKET OVER THOROUGHLY

In answer to your inquiry of how we like the 60-inch Columbia Sander which we purchased of you about a year ago, would say that it is giving perfect satisfaction. We looked the market over thoroughly before we purchased the Sander and decided on the Columbia. We are satisfied we made no mistake. The Oscillator is fine, and your Automatic Device for tightening the sandpaper while the machine is running is a great invention; also the device for adjusting the rolls on the inclines is the best we have ever seen. In fact, the machine in our opinion is the best on the market and we can cheerfully recommend it to any one who intends putting in a sander.

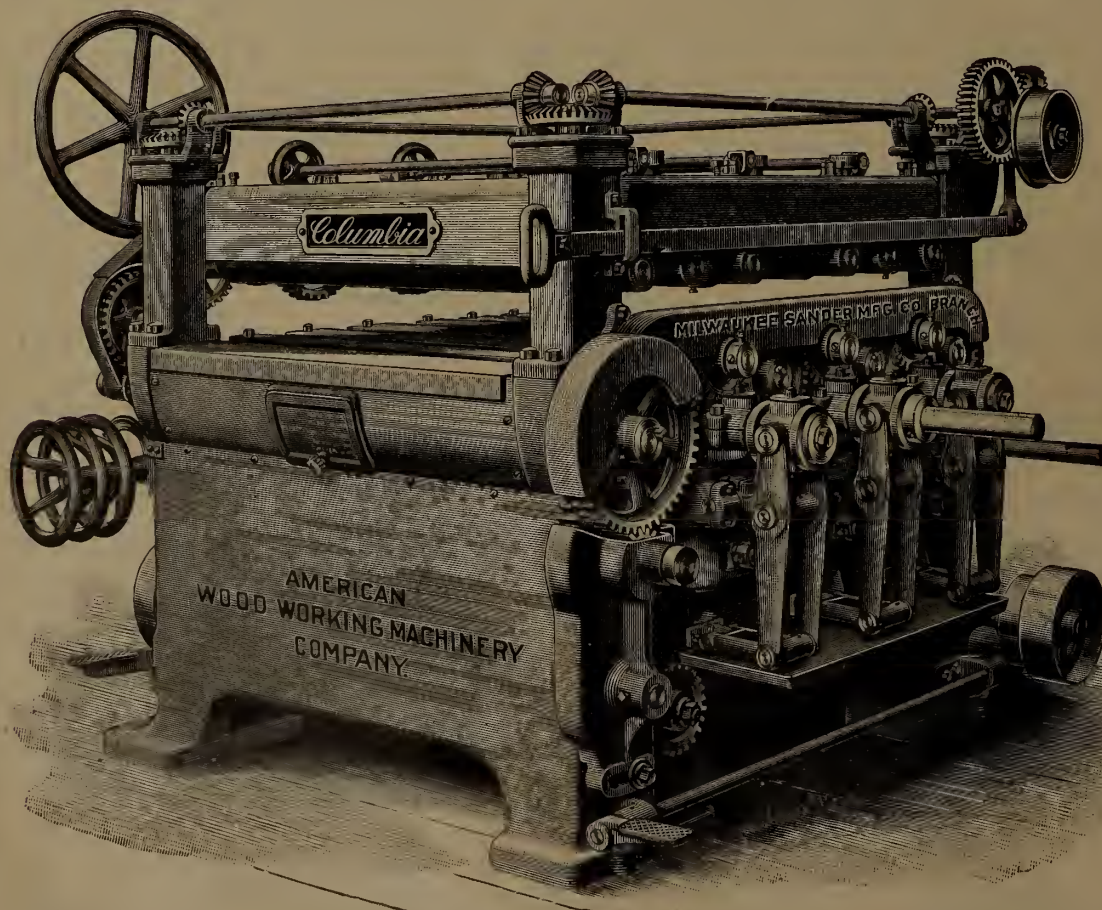

*Don't fail to get our
Sander Pamphlet
it tells the story*

AMERICAN WOODWORKING MACHINERY COMPANY

136 Liberty St.,
NEW YORK

43 Canal St.,
CHICAGO

Hennen Building,
NEW ORLEANS

Fig. 1070. Columbia Sanders. Built to work 30", 36", 42", 48", 54", 60", 66", 72", 78" and 84" wide.

SHERMAN'S FLOORING MACHINES

PATENTED



Above cut shows our End Matcher, the best machine in the market for end matching flooring strips. They do rapid and accurate work, and are durable—therefore used by leading flooring manufacturers. Make your flooring profitable by end matching it.

We Make the
SHERMAN SIDE BORING MACHINES
and the
SHERMAN FACE BORING MACHINES

To bore flooring while it is being run on the flooring machine. Write for circular and list of users

W. S. SHERMAN CO.
1150 Holton St., Milwaukee, Wis

Reliable Veterinary Remedies

No logging outfit is complete without a supply of reliable veterinary remedies. Getting the wrong kind means the loss of the use of your horses when time is valuable.

Johnson's Veterinary Remedies are guaranteed never to fail when used as directed. You get your money back if they ever do.

They are
Johnson's Horse Liniment No. 1.
A penetrating Alcoholic Liniment. Put up in one gallon jugs, with full directions, per imperial gal. \$4.50

Johnson's Horse Liniment No. 2.
A combination of the best oils used as liniments, imp gallon . \$3.00

Johnson's Horse Colic Remedy.
A sure and speedy cure for colic Imperial gallon \$5.00

Johnson's Veterinary Healing Ointment.
Positively the best all-round healing ointment made. In use by the largest owners of horse flesh in Canada. Put up in 2 lb tins, each . . . \$2.00
or in 1/4 lb tins, per dozen . . \$3.00

Johnson's Condition Powders. (Concentrated).
Put up in bulk, per lb. 3c.

These goods being put up in bulk are more economical than others, as cost of bottling, etc., is saved.

CAMP REMEDIES.

In addition to our Veterinary Remedies we make a line of medicines for lumbermen, including a strong, penetrating liniment, healing ointment, cholera cure, liver pills, cough syrup, in fact anything in the form of Camp Drug Supplies. We know that there are no better remedies made than those we offer. There may be others nearly as good, but they lack our guarantee. Satisfaction or money back. A trade discount of 10% allowed off all orders amounting to \$100.

Send postal for printed matter.

A. H. JOHNSON
Wholesale Druggist
Collingwood, Ont.



The Gordon Hollow Blast Grate Co.
Greenville, Michigan

The World's Largest
Manufacturer of

**HOLLOW BLAST GRATES
EDGERS AND
TRIMMERS**

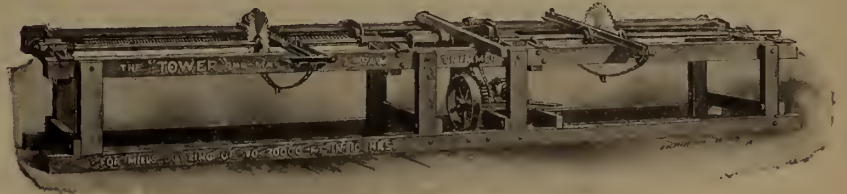

THE FAMOUS "TOWER" LINE OF TRIMMERS.—Emphatically the best 2-saw Trimmers made.

THE "TOWER" ONE-MAN TWO-SAW TRIMMER.—For mills cutting up to 30,000 feet in 10 hours.

There are two feeds, which may be instantly started, stopped or changed while the saws remain in motion, one lever controlling them both.

THE "TOWER" VARIABLE FEED ONE MAN TWO-SAW TRIMMER.—For mills cutting up to 30,000 feet in 10 hours.

ALL IRON AND STEEL

The only trimmer on the market with a
VARIABLE FEED

The manner of adjusting the saws in both of these trimmers
SAVES TIME, STEPS AND LUMBER

Each of these machines is built in five regular sizes.

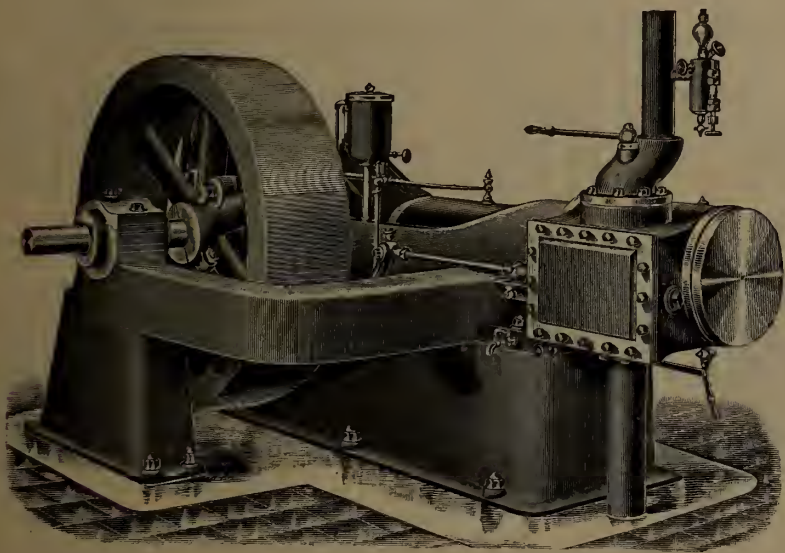

Our Engines are fitted with Automatic Governors and run at Regular Speed, whether Loaded or Light.

They use about 25 Per Cent Less Steam than the best engines with a throttling governor.

They are built on the Interchangeable System so that duplicate parts exact in fit can be supplied at any time.

In Sizes up to 125 Horse Power the outboard bearing is attached to the frame, as shown in the cut, keeping it perfectly in line.

ROBB ENGINEERING CO., LIMITED
Amherst, N.S.

Gonnell & Dengler Machine Co.

ROCHESTER, N. Y.

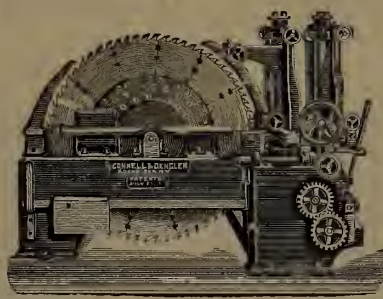

44 inch Circular Re-Saw.

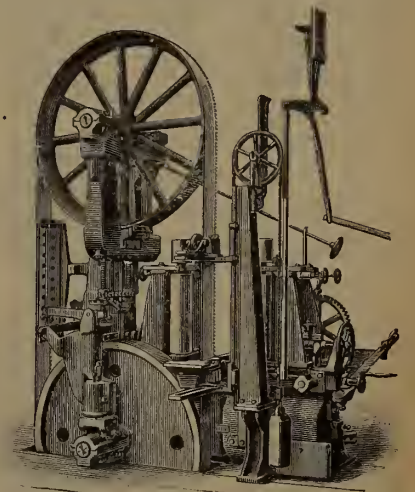

60 inch Band Re-Saw

Manufacturers
of . . .

**Box Makers' and
Planing Mill Machinery**



Heavy 26 inch Divided Roll Planer and Matcher with 8 Feed Rolls.

THE DYMENT FOUNDRY CO.

BARRIE, ONT.

Manufacturers of
ENGINES, BOILERS, STEAM FEEDS

AND A COMPLETE LINE OF

SAW, SHINGLE AND
LATH MILL MACHINERY

Can ship mills in a week's notice. Write us
for prices and catalogue.

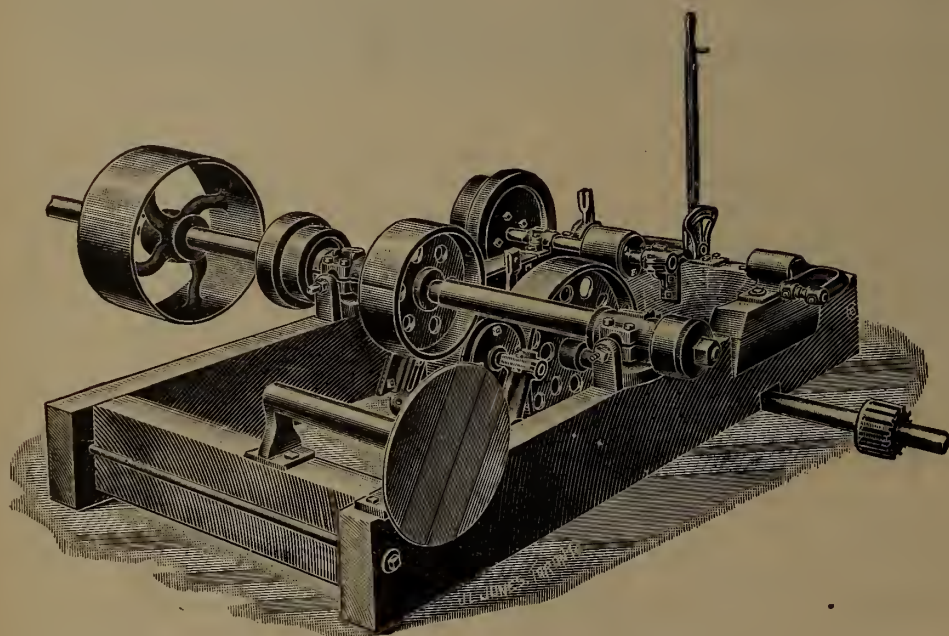
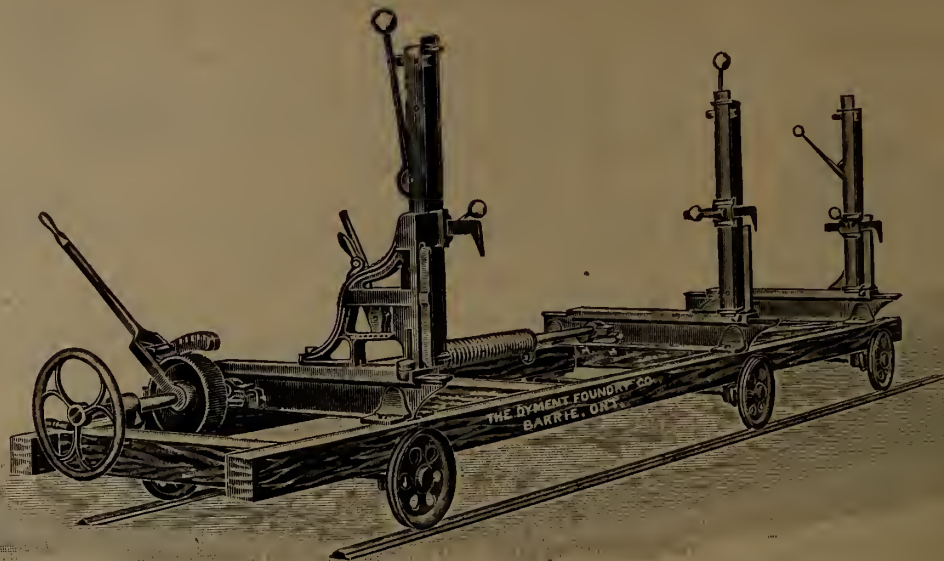

This is a light running Carriage and is quite suitable for small mills. Its capacity is about 15,000 feet per day. The wheels are 14 inches in diameter. The axles are $1\frac{3}{4}$ inches in diameter and go across frame. They are fitted with self-oiling boxes. The bunks are of steel. Blocks will recede 38 inches. An overset lever is supplied when desired, also spring receder and band brake wheel.

The feed on this frame is self-contained and can be used for either rope or rack and pinion. All the frictions have 7 inch face, two of them are made of paper, the other two of iron. The mandrel is made of steel and is 3 7-16 inches in diameter. The mandrel pulley is made in different sizes so as to suit the speed and width of drive belt. If desired this pulley may be put inside of frame.

WE MANUFACTURE AN IRON SAW FRAME

The **XXX** Saw Gummer and Sharpener

Has no Rival

FOR VARIETY, CAPACITY OR QUALITY OF WORK

OR FOR

SIMPLICITY, DURABILITY, CHEAPNESS

Will take saws from 6 inches to 6 feet diameter ; sets the saw forward one tooth at a time automatically ; sharpens any saw perfectly, giving the teeth any desired pitch, and making all the teeth exactly alike. Will sharpen 20 teeth in an ordinary saw mill in one minute, or 100 teeth in a shingle saw in four or five minutes. The cut shows outline of mill saw 54-inch diameter.

PEMBROKE, ONT.

MR. F. J. DRAKE, Belleville.

Dear Sir,—Re the conversation you had with our manager, I am instructed to inform you that the machine we purchased from you early last spring has proved to be a very useful piece of machinery. Our Mr. McCool, who uses it, is greatly pleased with it, and recommends it to any person who may require a Saw Filer. Wishing you every success with your Filer, we remain,

Yours truly,
(signed) THE PEMBROKE LUMBER CO.
Per W. H. Bromley.

SEND FOR CATALOGUE OF SAW MILL MACHINERY.

Manufactured Only by . . .

. . . **F. J. DRAKE,**

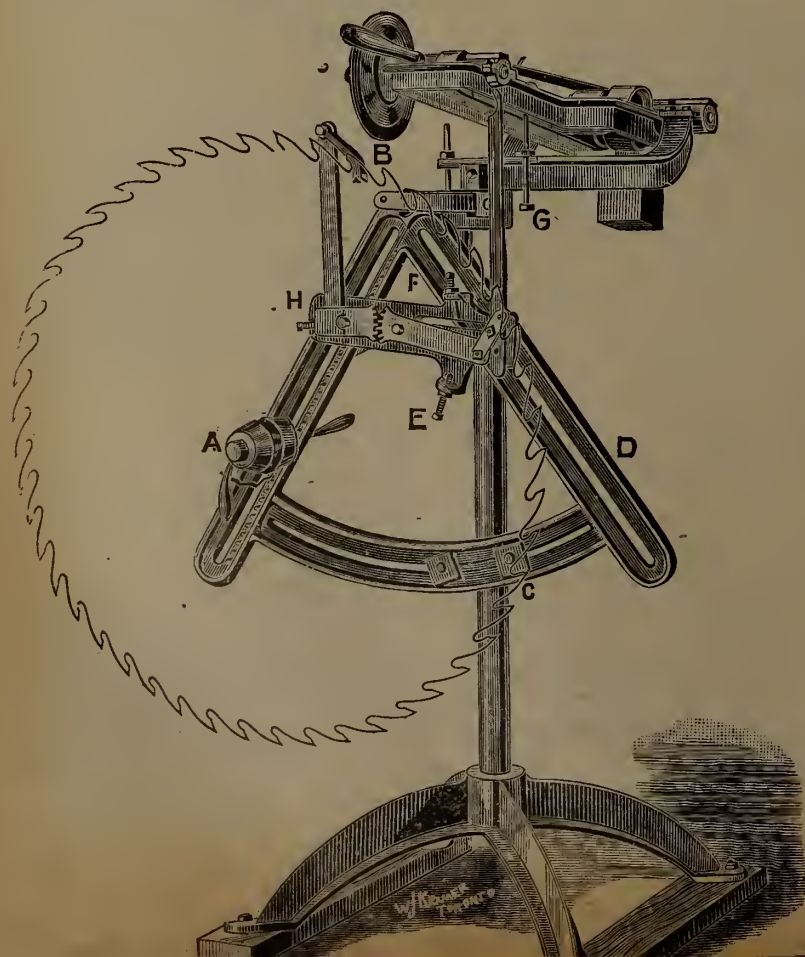

ATKINS ALWAYS AHEAD!



QUALITY IS THE THING!

Substance, not the Shadow of Quality

Characterizes the Silver Steel Saws bearing the celebrated "AAA" trade mark. Superiority of material, our patent process of tempering, perfection of grinding and experience and skill in workmanship are the leading features in the make-up of an Atkins Saw. These qualities insure perfect running saws and satisfaction to the user. The highest intrinsic value ever offered and the most efficient service possible to obtain are secured when you purchase an Atkins Saw. A trial is convincing proof. Think it over and let's have your order now.

Our Machine Knives, too, are made with a view of retaining you as a permanent, satisfied patron. What more can we say?

Mill Supplies of every description. Write for our 1905 Saw and Saw Tool Catalogue and Sawyer's Hand Book. It's free.

E. C. ATKINS & CO., Inc.,

Leading Manufacturers of Circular, Band, Cross-Cut, Hand and Wood Saws, Etc.

Factories and Home Office,
Indianapolis, Ind.

Canadian Branch,
56 King St East, Toronto, Ont.

THE E. L. PURVIS CO.,
18 COLBORNE ST., TORONTO, ONT.



PIPE AND BOILER COVERINGS

Asbestos Mineral Wool
and all kinds of Fireproofing

Material Agents for

FAMOUS MICA COVERINGS

Fire Clay Products

THE GLENYARDS FIRE CLAY CO.

BONNYBRIDGE, SCOTLAND.

Cablegrams: Glenyards, Bonnybridge.

Codes used, A.B.C. and Glenyards.

Manufacturers of all kinds of Fire Clay Goods, Ganister and Silica Goods, for Iron and Steel Works and Gas Works, including Boiler Seating Blocks and Covers of all sizes. Ground Fire Clay, Ganister and Silica in all kinds of Packages

Don't Hurry---Just Keep Moving

Operators of Shaping Machines—and others who know—will tell you that one-half of their time is devoted to "fitting up" and "getting ready."



OUR "SOLID STEEL SHAPER CUTTERS"

(GUARANTEED)

Are used by manufacturers who by experience know that the "first cost" is very small compared with the "continual cost" when "open heads" are used. OUR CUTTERS are always ready for use, which means "always something doing" on the Shaping Machine.

In ordering—send sample of mould, diameter of spindle, and size of collars.

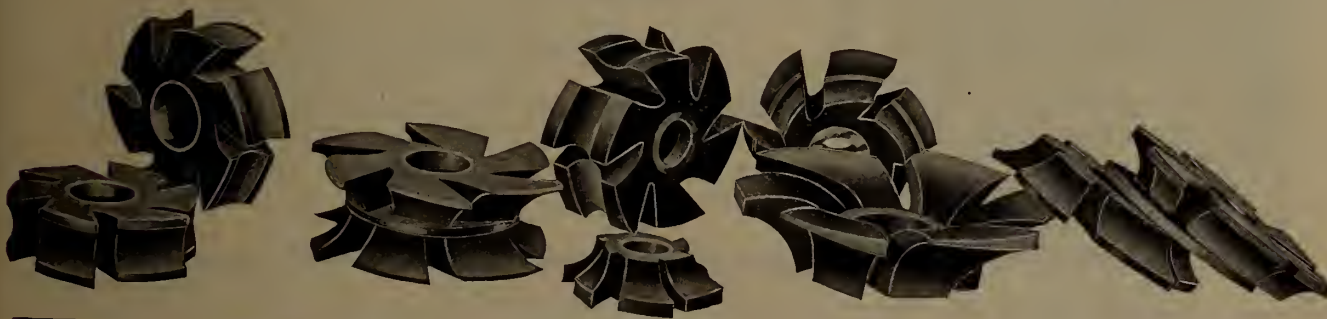

Furniture City
Tool Company

189 CAMPAU STREET, GRAND
RAPIDS, MICH., U.S.A.

AGENTS—

Harron, Rickard & McCone, San Francisco, Cal.
Schuchardt & Schutte, Berlin, Germany

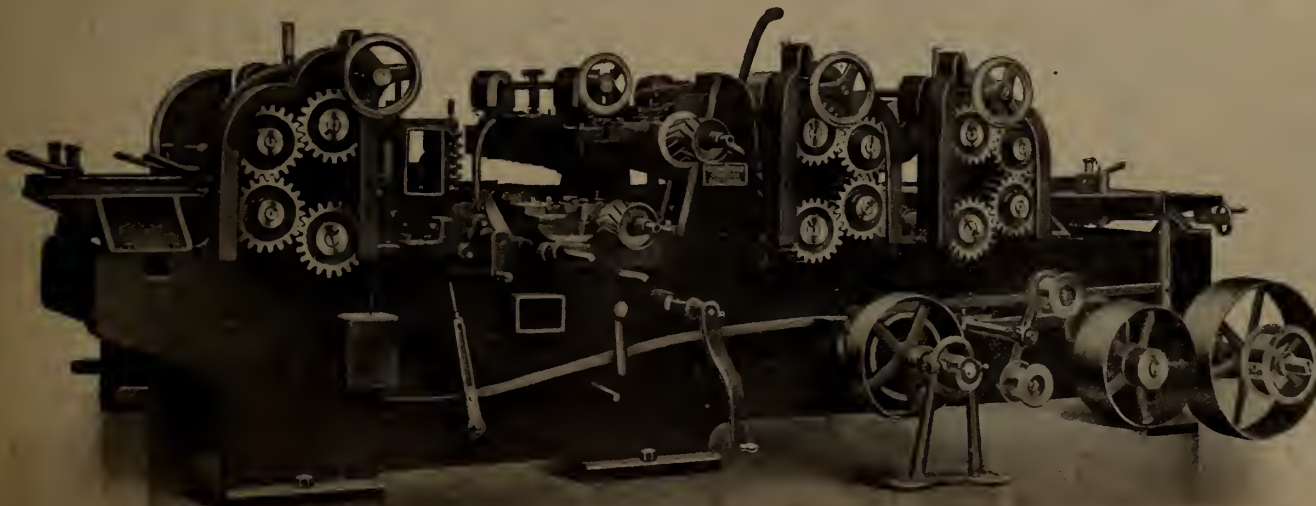

PLANER AND MATCHER

M 169

Made in several sizes; all fitted with wedge platen for instantly adjusting, regulating and distributing the cut between the cylinders; the greatest labor saver embodied in planing mill machinery. We manufacture a full line of wood working machinery. Write for prices and particulars.

COWAN & COMPANY

OF GALT, LIMITED

GALT, - CANADA

P. H. WRIGHT
 43 Bank Street OTTAWA
Lumbermen's Agent
 All kinds of Mill and Bush
 help secured on short notice
 Telephone 2586

H. J. FRIEL
 EMPLOYMENT AND LUMBERMEN'S AGENT
 Bushmen supplied on short notice, also
 mill hands. Hotel help of all kinds procured.
 Office: 73 BANK STREET
 Phone 721 OTTAWA

G. T. KNIGHT & SON
 Manufacturers of
Building Supplies
 we make a specialty of
 Doors and Sashes; Mouldings and all
 kinds of turned goods.
 Address, MEAFORD, ONT.

For the Cutting Department

CUT MATERIAL
 Board or Surface Measure Contents
AT A GLANCE
 from the time, labor and brain saving
BOX ESTIMATOR
 Sent on trial
JAMES M. LEAVER
 Sault Ste. Marie, Mich.

Standard Invaluable

of any Woodworking Plant

OILS
 Manufacturers High-grade Cylinder, Ma-
 chine and Sawmill Oils.

Calypsol Grease
 for Sawmill Purposes a Specialty.
 Our products are made from finest Penn-
 sylvania stocks.
 We solicit your correspondence.

St. John St.,
 MONTREAL.
 Commercial
 Oil Co.,
 Offices and Works:
 Manchester, Eng.
 Hamburg, Germany.
 Newark, N. J.
 Chicago, Ill.
 Hamilton, Ont

Please mention THE CANADA LUMBER-
 MAN when corresponding with
 advertisers.

FRANK DENTON, K. C. HERBERT L. DUNN
 W. MULOCK BOULTBEE.
DENTON, DUNN & BOULTBEE
 Barristers, Solicitors, Notaries, etc.
 National Trust Chambers. TORONTO

THE NEW
Dominion Saw Gummer
 Saw Gummer Cutters of all Descriptions
 MANUFACTURED BY
A. T. McLATCHIE, Cardinal, Ont.

DO YOU USE IT?
BAUGHMAN'S BUYER & SELLER
 THE HANDY BOOK FOR LUMBERMEN
 Saves half the time and all the mistakes in
 figuring Invoices, Estimates and Inventory.
 Send for sample copy.

Flexible Cloth \$1.00
 Flexible Leather 1.25
 Sample Page Free. Address
H. R. H. BAUGHMAN
 INDIANAPOLIS, IND, U. S. A.



Sole Canadian Agents Prices Reduced
WATEROUS, BRANTFORD, CANADA

MAPLE LEAF
STITCHED COTTON DUCK
BELTING
DOMINION BELTING CO. LTD.
HAMILTON CANADA

The Manitoba Gypsum Co.
 LIMITED
 MANUFACTURERS OF
 HARDWALL PLASTER WOOD FIBRE PLASTER
 PLASTER OF PARIS STUCCO ALABASTER
 and All Kinds of Gypsum Products

The Only Plaster Co. in Western Canada

Quality of goods superior to any imported article, our mill being equipped with the
 latest improved machinery.
 Dealers are invited to get our quotations before placing orders for Spring requirements
 Office: 811 UNION BANK BUILDING, WINNIPEG

D. E. ROBERTS Lately in charge of the Plymouth
 Plaster Co., at Fort Dodge, Iowa.
 Superintendent of Manufacture

WM. MARTIN
 General Manager

WANTED

Supplies
Beech, Maple or
Birch Cutwood

To be air-dried and cut from Prime Clear Stock.
 11 1/2" long x 7/8" and 15 1/2" long x 1" x 1".

Also
Maple or Sycamore Squares
 From 1 1/2" to 4" Square, rising by eights, and in
 multiples of 7" long up to 28".

Quote lowest prices per cubic foot deliver-
 ed c. i. f. Liverpool, England,
 to Box No. 50
CANADA LUMBERMAN

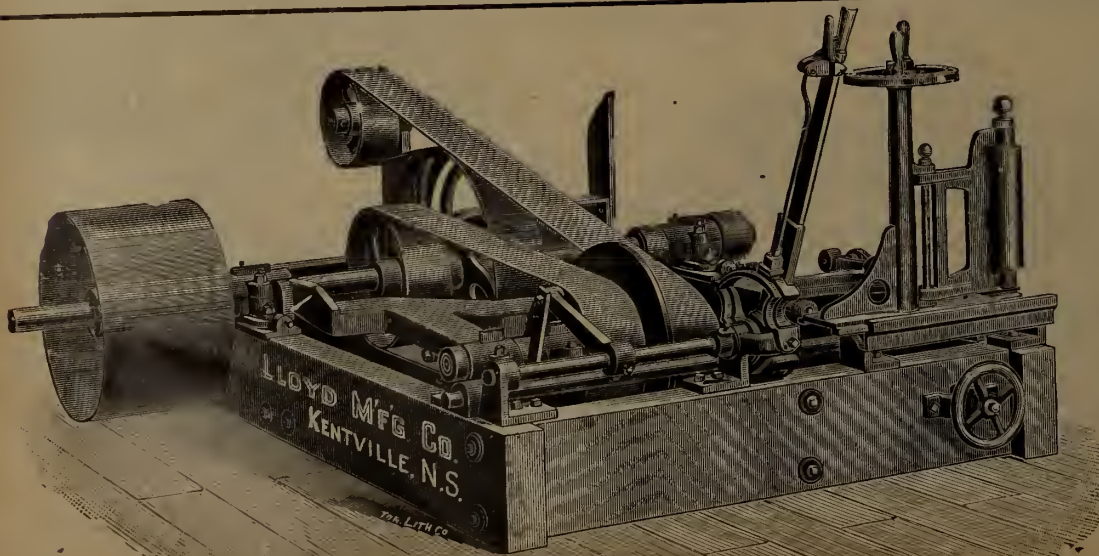

Lloyd Manufacturing
 Co'y JOHN I. LLOYD, Proprietor.

SAW MILL OUTFITS

Pulp Machinery, Belting, Etc.

OUR SPECIALTIES:
 Band Saw Mill Machinery, Power Feed Gang Edgers
 Improved Rotary Saw Mills, Buzz and Surface Planers,
 with Green Mountain Dogs, Heading Rounders,
 Also Screw Post Dogs, Stave Machines, Stave Jointers
 Turbine Water Wheels, Stave Planers.

KENTVILLE, N. S.

Dundas Lumberman

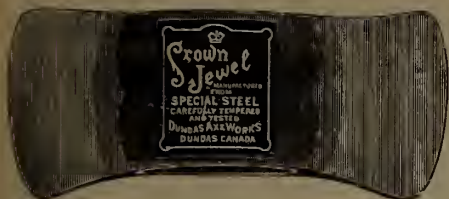

A New Axe tempered by a new process which enables us to submit to any lumberman three or more samples of Axes, all different degrees of hardness, and on a selection being made we will guarantee to furnish any number all exactly the same temper as sample chosen.

THE DUNDAS AXE WORKS
Dundas, Ont.

FOR THE CAMP TABLE

- Mess Pork
- Short Cut Pork
- Plate Beef
- Dressed Fresh Beef
- Long Clear Bacon, Butter, Cheese, &c.
- Smoked Hams
- Roll Bacon
- Pure Lard
- Pork Sausage

Write us for Special Prices on Car Load Lots.

THE PARK BLACKWELL CO., L'T'D
PORK AND BEEF PACKERS
TORONTO



MANUFACTURERS OF
INSERTED, SHINGLE, AND ALL SOLID-TOOTH CIRCULAR

SAWS

The Hastings Shingle Manufacturing Co., say :

"We wish to say that we have no saws in our mill, either shingle or cut-off that are giving us better satisfaction than yours, and our second order given you last week speaks more for your saws than anything we could say in this letter."

HOE BITS AND SHANKS AND ALL FILE-ROOM SUPPLIES
OLDHAM BAND SAWS

Repairs Executed Promptly. Inserted Tooth Saws Remilled and Refitted



THIS IS THE SHINGLE MACHINE

You need if greatest Capacity, Strength, Ease Economy of Operation is what you're looking for in a Shingle Machine.

THE COLUMBIA SHINGLE BLOCKER

Will produce 1,000 additional shingles from every 1,000 feet of logs—the only machine on the market capable of doing it, due to its point regulation. Write us about this perfect shingle producing machine, or about anything in the line of shingle machinery. We build a complete line from \$150 up.

PERKINS & CO. - Grand Rapids, Mich.

The Shimer Cutter Heads

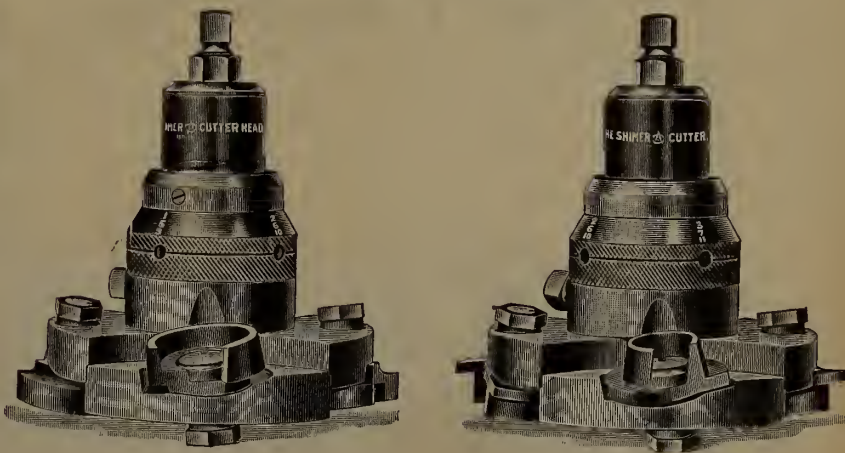

The expense that enters into the every day make-ready of the ordinary Cutter Heads is relegated as a thing of the past the minute you begin the use of The Shimer Cutter Heads.

The Bits have the shape of the pattern—a fixture in line with the cut, protected by the valuable clearance feature—the concave bit seat.

A very clear description is given in our latest Catalogue, No. 26, a copy of which we will be pleased to mail you.

SAMUEL J. SHIMER AND SONS
Milton, Pennsylvania

GANT FLIPS - - BOARD FLIPS

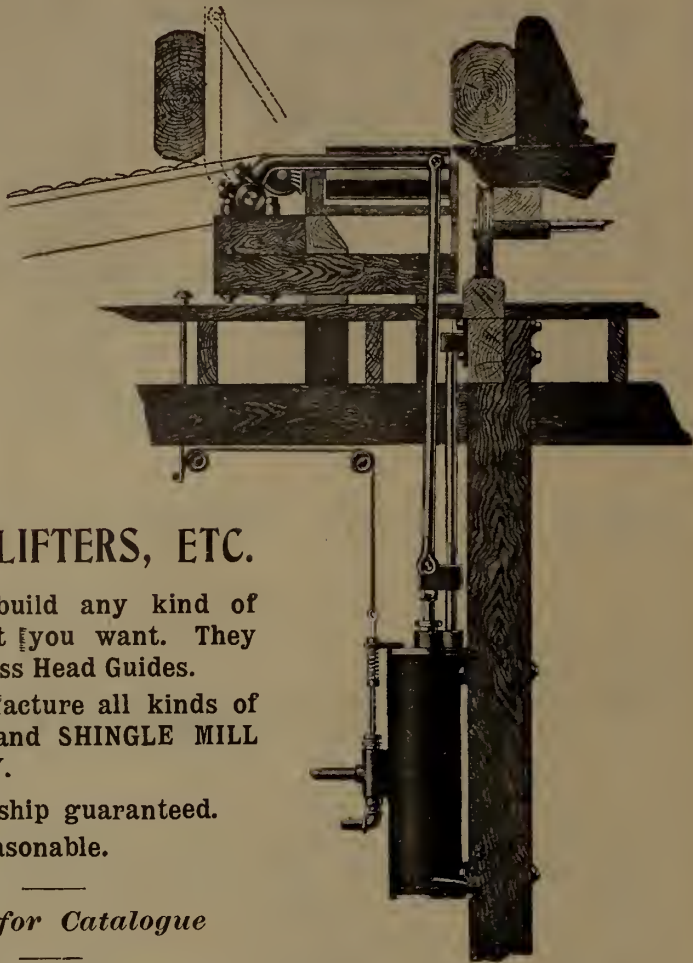

STOCK LIFTERS, ETC.

We can build any kind of a Flip that you want. They all have Cross Head Guides.

We manufacture all kinds of SAW MILL and SHINGLE MILL MACHINERY.

Workmanship guaranteed.
Prices reasonable.

Write for Catalogue

B. R. MOWRY & SONS,
GRAVENHURST, ONT.

**THE HOE
CHISEL TOOTH SAW
MAKES MONEY
FOR THE MILLMAN**

IMITATED
BUT
NEVER
EQUALED.

HOE & CO.
NEW YORK
PATENT SAW
CHISEL TOOTH
40,000 IN USE.

THE GENUINE MADE ONLY BY
R. HOE & CO.
504 TO 520 GRAND ST.
NEW YORK

A. D. A. M. H. A. L. L.

PETERBOROUGH, ONTARIO
CANADA

MANUFACTURER OF . . .

STEEL RANGES

For Lumbermen's and Railway Camps, Boarding Houses and Hotels

The Lumberman Heater

- 36 Inch Lumberman Heater
- 42 Inch Lumberman Heater
- 48 Inch Lumberman Heater

This Heater is used in heating Lumbermen's Camps, Boarding Houses, School Houses and large buildings.

The body of the Heater is made of Heavy Boiler Plate. The ends are made of Heavy Cast Metal, with a large Fire Door.

It is a perfect Heater, and very durable.

We have been manufacturing Steel Ranges and Heaters for Lumber Camps for the past Twenty-four Years, and have supplied the wants of nearly all the Lumbermen in Quebec, Ontario and Manitoba—they are unexcelled for Baking and Cooking, and are strong and durable.

This No. 10-25 Range with 25 Gallon Copper Reservoir is the one we sell the most of, owing to the convenience of having a supply of hot water at all times. Will cook for 50 to 60 men. Weighs 450 pounds.

Write for Catalogue and Price List.

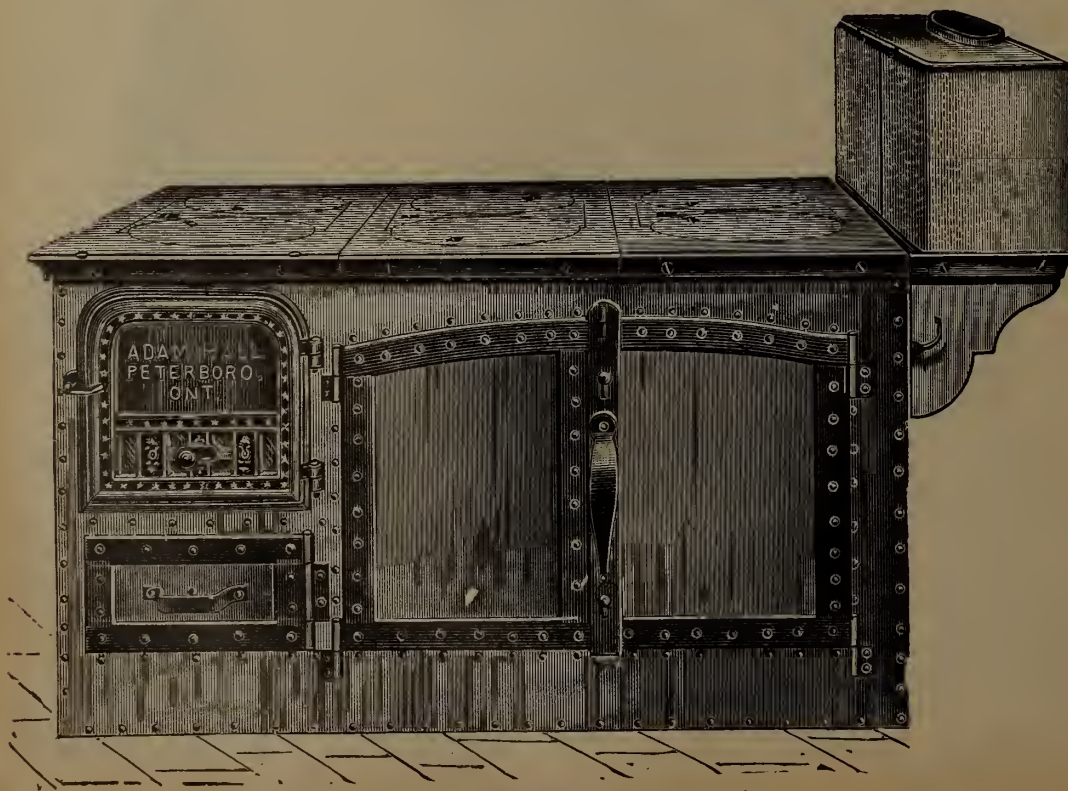

Lumbermen's Six Pot Hole Range with Reservoir.

Perfect Swing Shingle Mill

Fitted with our "Automatic Trip."

Best Swing Shingle Machine on the Market today for cutting Shingles, Headings, Etc. . .

It will pay you

to write for description and price before placing your order.

We also Manufacture a complete one of . . .

SAW MILL MACHINERY, ENGINES AND BOILERS

THE
Owen Sound Iron Works Co. LIMITED
Owen Sound, Ont.

SEND FOR CATALOGUE

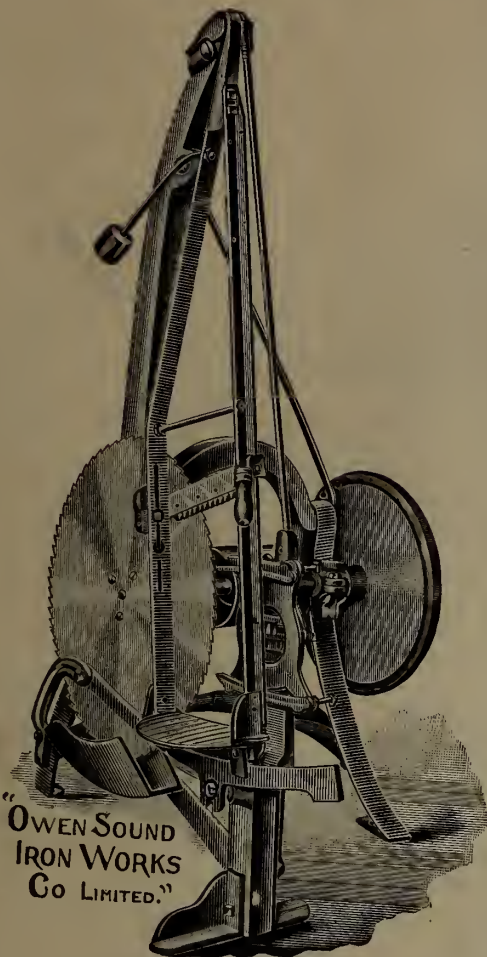

"OWEN SOUND IRON WORKS Co LIMITED."

RUBBER BELTING

For
Transmitting
Elevating
and
Conveying



Rubber
Hose
for
Water
Steam
Air
Suction
Fire
Protection

THE GUTTA PERCHA & RUBBER MFG. CO. OF TORONTO, LIMITED.

HEAD OFFICES: 47 YONGE STREET, TORONTO, CAN.

Branches: Montreal, Winnipeg.

New 200 Page Green Book
1904 EDITION.

"Saw and Knife Fitting Machinery and Tools"

MAILED FREE ON REQUEST.

A Book for Mill and Factory Managers, Superintendents, Foremen and Saw Filers.

BALDWIN, TUTHILL & BOLTON,
GRAND RAPIDS, MICH., U.S.A.



B. T. & B Full Automatic Knife Grinder. Style D

SAW AND KNIFE FITTING

THE NEW B. T. & B. MANUAL

Revised edition. 144 pages. Copiously illustrated and Durably Bound. Is an exhaustive treatise on the care of Saws and Knives.

A Practical Book for Saw Filers.

Mailed Postpaid on Receipt of Price

\$2.00

THE "B. T. & B." LINE

NEED ANYTHING ?

Sharpeners, Swages, Stretchers, Shapers, Side Files, Shears, Retoothers, Brazing Machines, Filing Clamps, Lap Grinders, Lap Cutters, Patch Machines, Crack Drills, Hammering Benches, Bench Grinders, Band Filers, Band Setters, Pulleys and Stands, Brazing Forges, Saw Sets, Saw Gauges, Swage Bars, Upsets, Straight Edges, Tension Gauges, Back Gauges, Leveling Blocks, Anvils, Hammers, Speed Indicators, Emery Dressers, Knife Grinders, Knife Balances, Shingle Saw Grinders, Burr Gummers, Post Brackets, Stretcher Bench Brackets, Cutters, Marking Stamps, Saw Guides, etc.

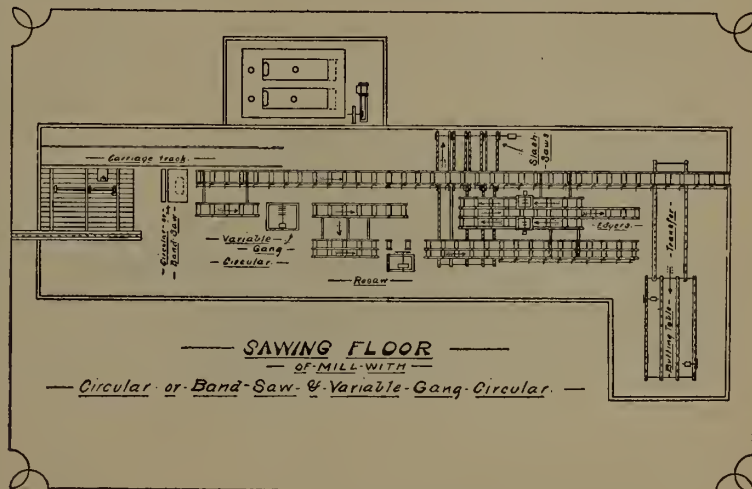

Sawing Floor of Mill with Circular or Band Saw and Variable Gang Circular

For cutting large and small logs at the same time, profitably, this mill has no equal. The variable Gang Circular (which takes the place of an upright gang, does as much work, and can be placed for 1/2 the cost of an iron frame gang) cuts the cants into any thickness from 1" to 9" by whatever width the cant has been slabbed to up to 10", and each cant put through may be cut into different sizes from the one immediately preceding or following it. Plans and estimates made of all kinds of sawmill work; machinery supplied and mills built if desired.

I. N. KENDALL

203 BRIDGE ST.

OTTAWA, ONT.

**OUR
BIG**

CHAMPION EDGER

is the Heaviest and Most Substantial
Edger Built in Canada

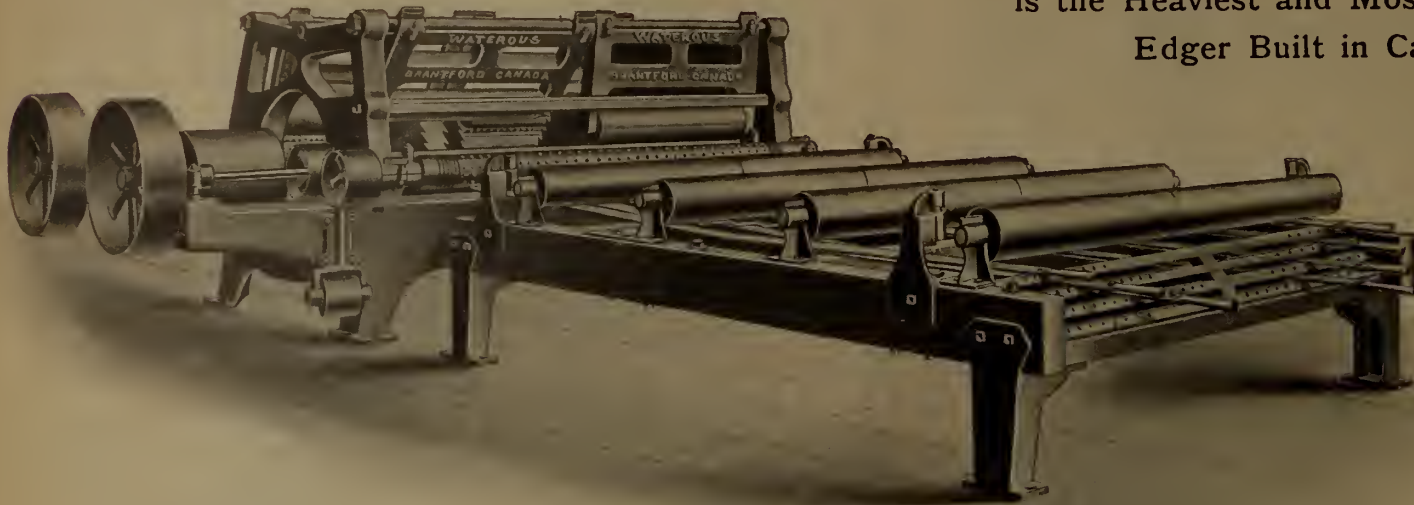

In Five Sizes, from
54 to 96 inch

Can be arranged with
Cluster Collar and
Variable Feed

Usual Speed of Feed,
360 feet per minute

FRONT VIEW—shows adjustable tightener for feed belt to outer rolls. Has three water-cooled boxes—two at driving end—all detachable. All bearings piped for water connections. A most positive feed is secured by one spiked and one fluted roller in front and rear—all driven. Saws 26 inch in diameter. All are movable and guide roller stationary.

The special lever arrangement shown in cut is the best known method for moving saws, being so arranged that the pressure on saw is always parallel, notwithstanding angle of lever, and lever is so wide there is no side spring, so that the movement of saws is absolutely correct.

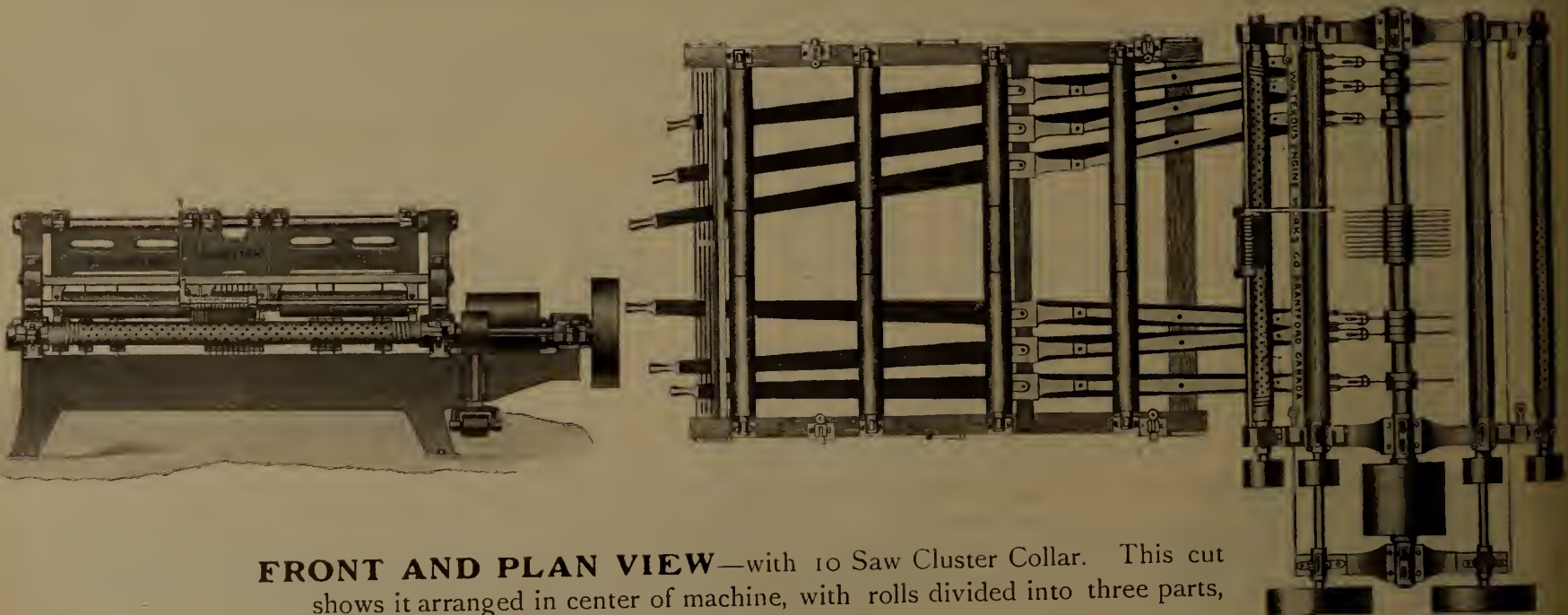

FRONT AND PLAN VIEW—with 10 Saw Cluster Collar. This cut shows it arranged in center of machine, with rolls divided into three parts, can be placed at either side if preferred.

A special Variable Feed Works is required below edger floor, so that when heavy cutting is being done with Cluster Collar the operator can by a lever reduce feed instantly to such a reduction as feed is arranged for, generally to 150 feet per minute.

Send for Special Circular and Price

WATEROUS, Brantford, Canada

NATURAL DRAFT MOIST AIR . . . **DRY KILNS**

LUMBER TRUCKS and TRANSFER CARS

Write for prices and particulars of the most simple and efficient Natural Draft Dryer on the market. Testimonials and list of users sent on application. Every square inch of heating surface is utilized to the uttermost and perfect ventilation and circulation is obtained by a very simple arrangement of ducts. Write for particulars to

SHELDON & SHELDON,
GALT, ONT.

FORMERLY McEACHREN HEATING & VENTILATING CO.



Experimenting with Dry Kilns is an Expensive Luxury

Why keep on using a Kiln that has to be regulated with dampers, chimneys and complicated fans. Put in a Morton Automatic Moist Air Kiln and your Dry Kiln troubles will be ended. We do not sell a man a Dry Kiln to dry Mahogany and then tell him it will dry Basswood staves. Our thirty years experience in the Dry Kiln business yours for the asking.

Write to-day for Illustrated Catalogue "C"

The A. H. Andrews Co.

174-176 Wabash Avenue - - - CHICAGO, U.S.A

Eby Machinery Co., Western Agents, 17-19 Main St., San Francisco, Cal.

H. G. Boardman, Eastern Agent, 1170 Broadway, New York.



THE HIGHEST ACHIEVEMENT IN TRUCK CONSTRUCTION

Standard Dry Kiln Trucks are best for **your** plant because they run more lightly, give less trouble and last longer than any other truck on the market. This we prove and guarantee.

Not only do they possess every modern feature of truck construction, but a number of the most valuable points about them are patented by us and cannot be reproduced in other trucks.

Standard Trucks have **malleable iron** wheels and spreaders ; channel steel frame ; steel rollers with **cone-shaped ends** that minimize the friction ; **lath-cut** axles with milled ends, and many other advantages that are explained and illustrated in our printed matter.

Write for our Catalogue "D" and learn more about these better dry kiln trucks.

The Standard Dry Kiln Co.
Indianapolis, Indiana

SAW MILL OPERATORS are finding that

"MIDLAND" BEARING METAL

is all that WE CLAIM FOR IT

and then it is sold for only

15 CENTS A POUND

You will be pleased if you will give us a trial order

GEORGIAN BAY ENGINEERING WORKS

Midland, Ontario

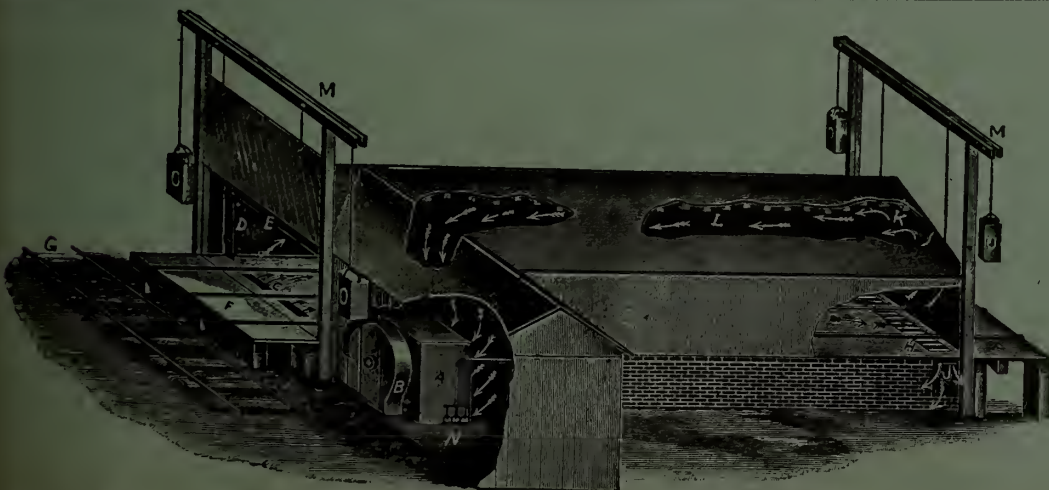

FOR **DRY KILNS**

that will season lumber of **all kinds** and **under all conditions**, whether **partially air-seasoned** or **green from the log**, in shortest time and at least cost, **entirely free from checking, warping or case hardening,**

Write to—

McEACHREN HEATING & VENTILATING COMPANY, GALT, CANADA

HUTHER BROS. PATENT GROOVER OR DADO HEAD
For cutting any width groove from 1/4-inch to 2 inches or over

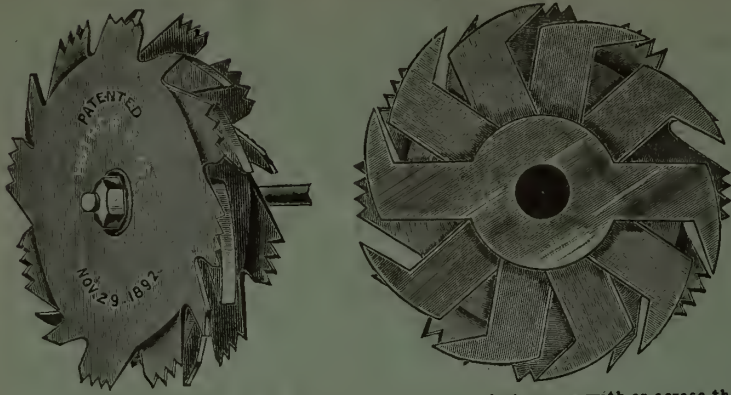

Can be used on any Circular Saw Mandrel. Will cut a perfect groove with or across the grain. This is the only Dado Head on the market that gives entire satisfaction on all classes of work. No screw adjustment. For different width grooves, simply remove or add inside cutters. Sold by builders and dealers of woodworking machinery in all parts of the United States. Will send on approval, in competition with any other make on the market; if not the best return at our expense. HUTHER BROS., Platt Street, ROCHESTER, N.Y., manufacturers of Circular Saws, Morgan Pattern Lock-Corner Box Cutters, Concave Saws, etc.

RIGE LEWIS & SON,
Limited

S
A
W
S

Chain	Steel
Bolts	Iron
Files	Horse Shoes

A
X
E
S

Peaveys	Boot Calks
Pike Poles	Lumber Leads
Cant Hooks	Timber Grips

R
O
P
E

TORONTO.

Write for Prices



AUTOMATIC
FEED PUMP AND
RECEIVER

STEAM and BROWN
PUMPS

ENGINES
BOILERS

THE
SMART TURNER
MACHINE COMPANY
Limited.
Hamilton - Ontario

Uncle Sam would not allow his battleships to be babbitted with inferior babbitt metal. New Battleship "Nebraska" is lined with Syracuse Babbitt. Always specify best. It is cheapest in the long run.

SYRACUSE SMELTING WORKS

MONTREAL NEW YORK SEATTLE

CRESCENT MACHINERY

Quality is all right.
So's the price.

- Band Saws
- Jointers
- Saw Tables

Very low price on
BAND SAW BLADES
Catalogue tells the rest.

H. W. PETRIE
Dept. C. M.
TORONTO, ONT.

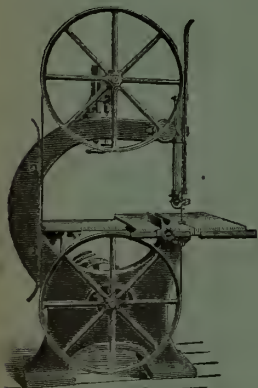

THE
LEATHER BELT
THAT'S
KNOWN
OUR
"EXTRA"



MONTREAL TORONTO
WINNIPEG VANCOUVER

PINK LUMBERING TOOLS

The Standard Tools

In Every Province of the Dominion, * * * * *
* * * * * New Zealand, Australia, Etc.



Pink Round Bill Peavey, Handles in Split Maple;

Pink Duck Bill Winter Cant Hook, Handles in Split Maple.

**FINEST QUALITY
SPLIT MAPLE
CANT HOOK AND
PEAVEY HANDLES,**

**Boom Chains,
Pike Poles,
Skidding Tongs**

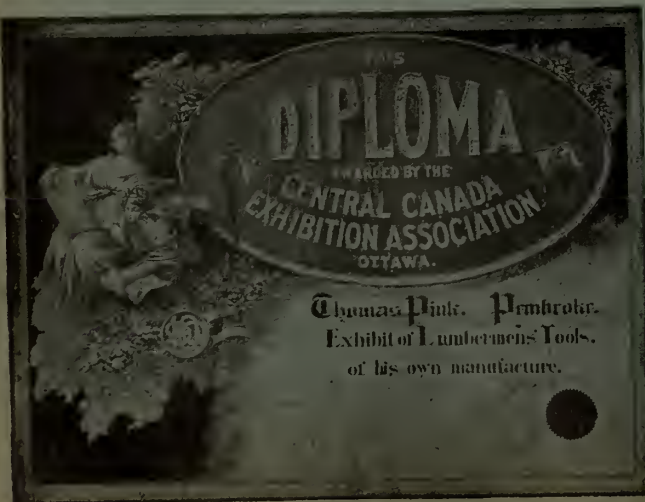

THOMAS PINK
Pembroke, Ont.

THE CANADA LUMBERMAN AND WOOD-WORKER

REACHES REGULARLY THE MANUFACTURERS AND BUYERS AND SELLERS OF TIMBER PRODUCTS IN EVERY PART OF CANADA AND LEADING IMPORTERS ABROAD

VOLUME XXV. }
NUMBER 8

TORONTO, MONTREAL — AUGUST, 1905 — WINNIPEG, VANCOUVER

{ TERMS, \$1.00 PER YEAR
{ Single Copies, 10 Cents.

SNOW PLOWS

Logging Sleighs
Heavy Waggon

THE WILKINSON PLOUGH COMPANY, LIMITED
TORONTO, CANADA

SANDVIK SWEDISH STEEL

The Canada Saw Co.
LIMITED
Factories at: Ottawa Montreal Toronto St. John, N. B.]

Sandvik Swedish Steel
Band, Gang and Circular Saws
P. M. FEENY, Manager.

OIL TEMPERED

Which is Wisest?

Some people buy Belting on price, others on quality. Which is wisest?

J. L. GOODHUE & CO.,
DANVILLE, QUEBEC.

D. K. McLaren

GENUINE

Oak Belting
MILL SUPPLIES

751 Craig St., Montreal.
196 King Street West, Toronto

WOODS LIMITED

.. Wholesale Manufacturers of ..

LUMBERMEN'S AND CONTRACTORS' SUPPLIES

INCLUDING

Tents, Flags, Awnings, Tarpaulins, Clothing, Overalls, Shirts, Mitts, Underwear, Blankets, Axes, Moccasins, Woods Celebrated Eider Down Sleeping Bags

WOODS BUILDING - OTTAWA, CAN.

SEND FOR H. W. PETRIE'S
MONTHLY STOCK LIST
NEW & 2ND MACHINERY
TORONTO, CANADA

DICK'S BELTINGS



Never is affected by wetness, and does not stretch

Excels in Transmission Power

Always Uniform.

LARGE STOCK ON HAND

WRITE TO SOLE AGENTS:
J. S. YOUNG, 14 Hospital Street MONTREAL

New and Relaying

RAILS

Light and Standard Sections

TRACK TOOLS CAR MOVERS
WIRE ROPE AND FITTINGS
Manila Rope in Full Coils and Cut Lengths
W. H. C. MUSSEN & CO.,
MONTREAL

THE E. R. BURNS SAW CO.

TORONTO, ONT.

MANUFACTURERS OF HIGH-GRADE

Circular and Long Saws

UNEXCELLED

SHINGLE SAWS

OUR INSERTED TOOTH SAWS POSITIVELY THE BEST



The Wm. Hamilton Mfg. Co., Limited

Builders of a Complete Line of

SAW MILL MACHINERY

We are specialists in the building of sawmill machinery—we have been making it, and making it well, for nearly fifty years.

Surely our machines must have merit—must have lived up to all our claims, or we would not be in business to-day.

Back of every machine we sell is our guarantee against its failure due to defective material or workmanship, and our warranty of its successful operation.

All our machines are of simple design and enduring construction.

—

We are specially well equipped for handling repair jobs, and can give your orders prompt attention.

—

Can we not send you our catalogues?
Write Department L for them.

Our Line Includes

Engines and Boilers

Band Mills

With Weight or Steam Tension

Gangs

Carriages

Husk Frames

Log Handling Machinery

Edgers

Trimmers and Slashers

Steam, Hand and

Power Set Works

Lath Mill, Shingle Mill

and Filing Room Machinery

Twin Circulars

Tie Mills

Burners

Head Office and Works: PETERBOROUGH, ONTARIO

Allis-Chalmers-Bullock, Limited

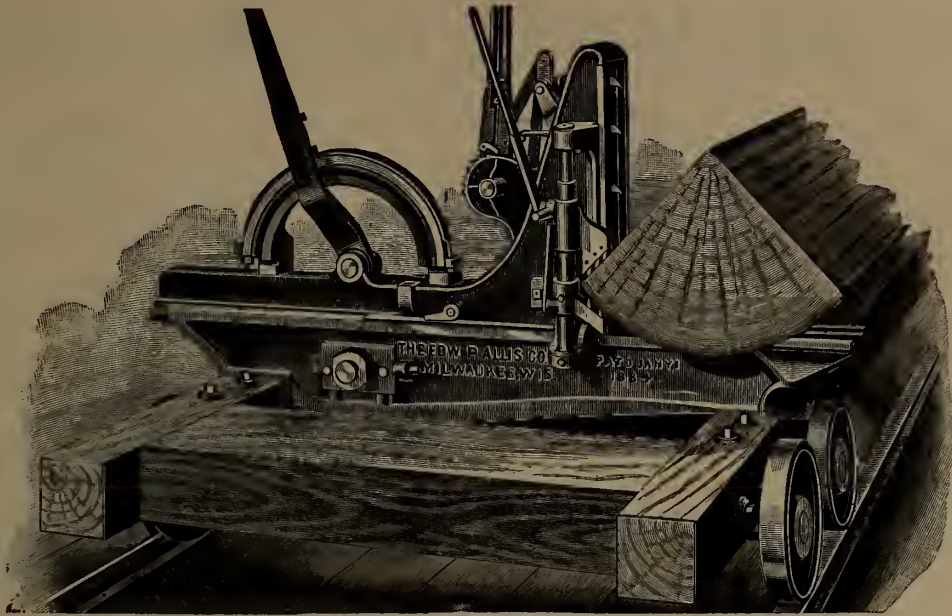

A QUARTERED LOG DOG.

A right-hand dog is shown holding the timber in position for the saw.
 Send for our latest leaflets on circular saw mills, horizontal band resaw mills, six foot band mills, new Allis vertical valves for steam feeds and No. 2 heavy timber edger.

Works : Montreal. Branch Offices : Halifax, Toronto, Winnipeg, Nelson, Vancouver

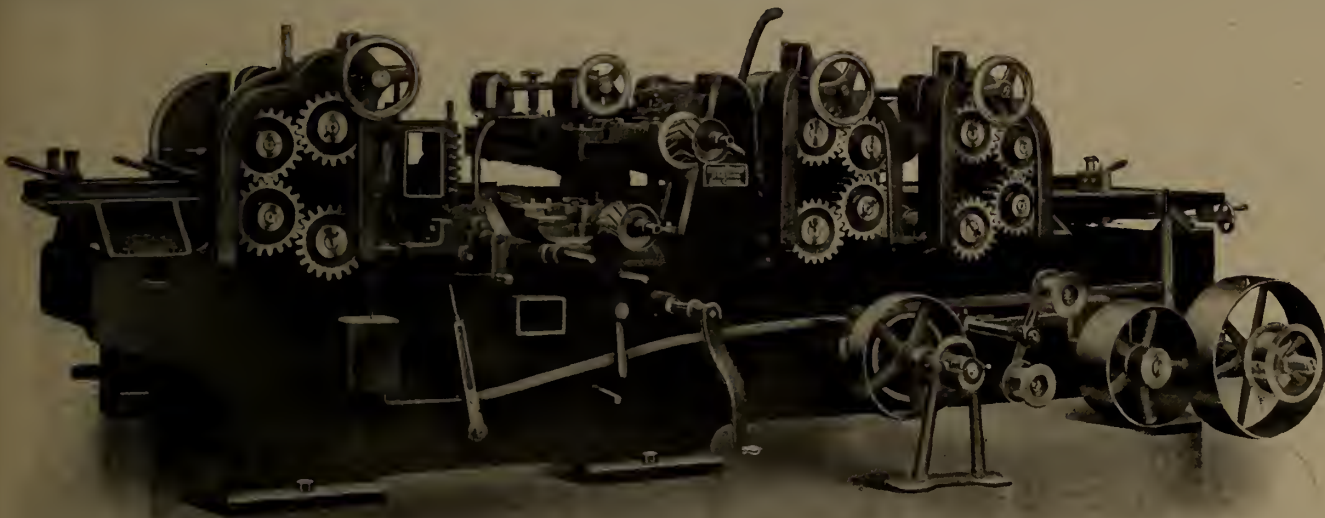

PLANER AND MATCHER

M 169

Made in several sizes ; all fitted with wedge platen for instantly adjusting, regulating and distributing the cut between the cylinders ; the greatest labor saver embodied in planing mill machinery. We manufacture a full line of wood working machinery. Write for prices and particulars.

COWAN & COMPANY

OF GALT, LIMITED
 GALT, - CANADA



Fairbank's Wood Split Pulley—Made in Canada

Belting, Pulleys, Shafting

Hangers, Files, Drills

Emery Wheels, Belt Hooks, Lace Leather

IN FACT EVERYTHING FOR THE MILL

SEND US YOUR NEXT ORDER

THE CANADIAN FAIRBANKS CO., LIMITED

MONTREAL

TORONTO

VANCOUVER

WINNIPEG

BRITISH COLUMBIA LUMBER AND SHINGLE MANUFACTURERS

The Canadian Pacific Lumber Co., Limited
PORT MOODY, B. C.

Manufacturers and Wholesale
Dealers in All Kinds of

B. C. LUMBER, LATH, MOULDINGS, ETC.

Special Attention Given to Orders from Manitoba and the Territories

Long Distance
Telephone Connection.

Address the Company at Port Moody or
BYRNES & CUDDY, Selling Agents, WINNIPEG

PETER LUND, Managing Director.

J. BRECKENRIDGE, President.

MANUFACTURERS OF
ALL KINDS OF

**Grows Nest Pass
Lumber Co., Limited**
WARDNER, B. C.



BUILDING MATERIAL

Capacity 150,000 Feet Per Day.

Columbia River Lumber Company, Limited
HEAD OFFICE AT GOLDEN, B. C.

Largest Capacity in Mountains

MILLS AT { GOLDEN, B. C.
BEAVER, B. C.
KAULT, B. C.
CARLIN, B. C.

ROUGH AND
DRESSED

LUMBER

FIR, SPRUCE
CEDAR AND PINE

LATH

Telephone Poles,
Piling, Etc., a
Specialty.

The Fernie Lumber Co., Limited, Fernie, B. C.

MANUFACTURERS OF AND DEALERS IN ALL KINDS OF

ROUGH AND DRESSED LUMBER

Dimension and Bridge Timber a Specialty.

Moulding in Stock or Made to Order.

JOS. GENELLE, Manager.

J. G. BILLINGS, Secretary.

THE YALE-COLUMBIA LUMBER COMPANY, LIMITED

Head Office: NAKUSP, B. C.

Mills at Nakusp, Westley and Cascade, B. C.

MANUFACTURERS OF

DEALERS IN

All Kinds Rough and Dressed Lumber,
Mouldings, Lath, Etc.

Cedar and Fir Piles, Telephone and
Telegraph Poles, Fence Posts, Etc.

NORTH STAR LUMBER COMPANY,

Head Office and Shipping Yards: ELKO, B. C.

Mills: CRANBROOK, B. C.

At present we have the following material in stock at Cran-
brook, B. C.:

- 1,750,000 ft. Common Boards.
- 300,000 " Stock Boards, 8 in., 10 in. and 12 in.
- 300,000 " Ship'ap, 8 in., 10 in. and 12 in.
- 100,000 " Flooring, Siding and Ceiling, 4 in. and 6 in.
- 1,550,000 " Dimensions, 8 to 24 ft.

We have a large quantity of 18 and 20 ft. lengths, from 2 x 4's
to 2 x 12's.

The above is manufactured from a superior quality of pine, fir and
tamarack logs. 75 per cent. of it is "bone dry."

Special sized timbers cut on short notice. Write for prices.

MANUFACTURERS OF AND WHOLESALE
DEALERS IN



BAYARD, B. C.

**B. C. WHITE PINE
LUMBER and LATH**

Write Us About Our LARCH LUMBER

Factory Lumber
and
Tank Stock

A Specialty

BRITISH COLUMBIA LUMBER AND SHINGLE MANUFACTURERS

BLUE & DESCHAMPS

Manufacturers of

Tamarac, Hemlock, Spruce
Fir, Cedar and White Pine

MILL AND OFFICE: ROSSLAND, B. C.

China Creek Lumber Co., Limited

Manufacturers of

Fir, Tamarac and Yellow Pine

WE MAKE LATH

Mill at CHINA CREEK

Office at ROSSLAND, B. C.



THE PIGEON RIVER LUMBER COMPANY PORT ARTHUR, ONT

MANUFACTURERS OF

Band Sawed White Pine Lumber, Lath, Pine and Cedar Shingles.

are operating their extensive plant night and day, to keep abreast with orders.

THERE IS A REASON—

A trial order will tell you why.

Winnipeg Representative,

D. J. McDONALD, Clarendon Hotel.



CEDAR LUMBER

Manufacturers and Shippers

Cedar, White Pine, Fir
Lumber, Lath, Mouldings, Shingles

Bowman Lumber Co., Ltd.
Revelstoke, B. C.

Mills at { REVELSTOKE, B. C.
COMAPLIX, B. C.

ROSS BROS & CO.

FORMERLY OF WHITEMOUTH, MAN.

SUCCESSORS TO THE ELKMOUTH LUMBER CO.
ELKMOUTH, BRITISH COLUMBIA

Full Lines Kept in

Pine, Fir and B. C. Tamarac

ORDERS RESPECTFULLY SOLICITED

Send for Our Prices

The Ladysmith Lumber Co., Limited

LADYSMITH, B. C.

Manufacturers of

LUMBER, LATH, SHINGLES,
MOULDINGS, ETC.

SPECIALTY: The best Cedar Shingles manufactured on the Coast.

FRESH WATER FIR LATH ALWAYS IN STOCK.

Capacity of Shingle Mill, 100,000 per day of 10 hours.

Correspondence Solicited

THE EAST KOOTENAY LUMBER CO., Limited

Saw and Planing Mills at Ryan, Cranbrook and Jaffray, B. C.

Capacity, 150,000 Feet Per Day

MANUFACTURING

LARCH

PINE and FIR

Lumber, Timber, and all kinds
of Mouldings, also dealers in
Railway Ties, Piles and Poles

Large Stocks of Well Seasoned Dry Material Always on Hand

HEAD OFFICE

CRANBROOK, B. C.

"DEFIANCE" Wood-Working Machinery

For Manufacturing
**HUBS, SPOKES, WHEELS, WAGONS,
CARRIAGES, RIMS, SHAFTS, POLES,
NECK-YOKES, SINGLE TREES, BARREL
HOOPS.**

Handles of Every Kind, Insulated Pins, Spools,
Bobbins, Oval Wood Dishes, and General Wood-
Work.

Invented and Built by

THE DEFIANCE MACHINE WORKS,
Defiance, Ohio, U. S. A.

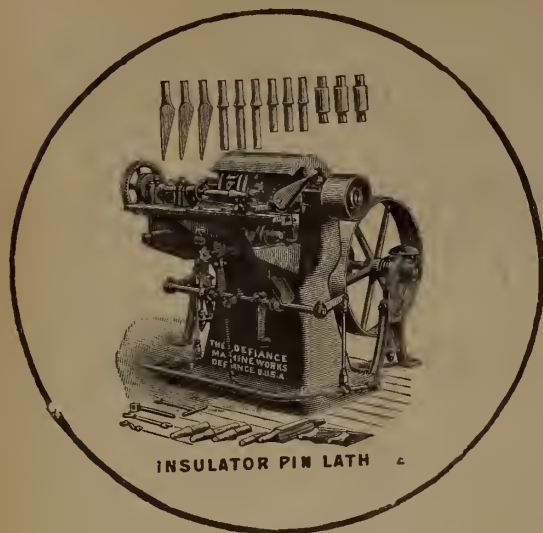

INSULATOR PIN LATH

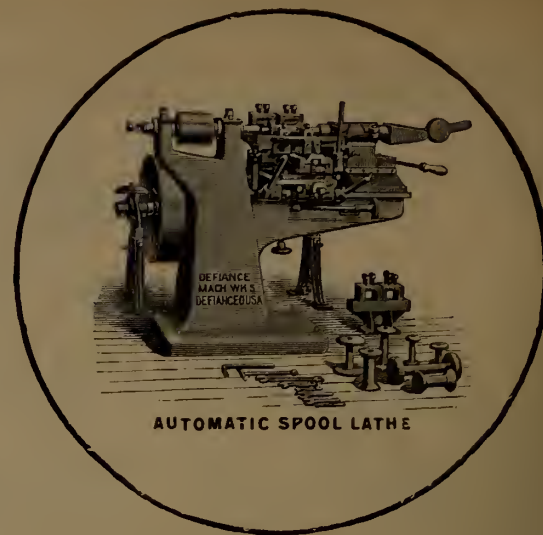

AUTOMATIC SPOOL LATHE

The "Alligator" Steam Warping Tugs

SIDE WHEELS OR TWIN SCREWS

The Twin Screws are arranged with flexible joint to
raise up in crossing portage

MANUFACTURED BY

WEST & PEACHEY, - Simcoe, Ont.

Cables carried in stock for renewals



Pure Manila Rope

HIGHEST QUALITY MADE

British Manila

Sisal Rope

PURE SISAL

Lath Yarn

Wire, Write or Phone

Canadian Cordage & Manufacturing Company, Limited

Toronto, Ontario, Canada

Long Distance Phone 162

Our Rope and Lath Yarn are Recogniz-
ed as the Best on the Market.



FRANK DENTON, K. C. HERBERT L. DUNN
W. MULOCK BOULTBEE.
DENTON, DUNN & BOULTBEE
Barristers, Solicitors, Notaries, etc.
National Trust Chambers. TORONTO

DO YOU USE IT?
BAUGHMAN'S BUYER & SELLER
THE HANDY BOOK FOR LUMBERMEN
Saves half the time and all the mistakes in
figuring Invoices, Estimates and Inven-
tory. Send for sample copy.
Flexible Cloth \$1.00
Flexible Leather 1.25
Sample Page Free. Address
H. R. H. BAUGHMAN
INDIANAPOLIS, IND, U. S. A

THE NEW
Dominion Saw Gummer
Saw Gummer Cutters of all Descriptions
MANUFACTURED BY
A. T. McLATCHIE, Cardinal, Ont.

For the Cutting Department
CUT MATERIAL
Board or Surface Measure Contents
AT A GLANCE
from the time, labor and brain saving
BOX ESTIMATOR
Sent on trial
JAMES M. LEAVER
Sault Ste. Marie, Mich.
of any Woodworking Plant

The Manitoba Gypsum Co.

LIMITED

MANUFACTURERS OF

**HARDWALL PLASTER WOOD FIBRE PLASTER
PLASTER OF PARIS STUCCO ALABASTER**
and All Kinds of Gypsum Products

The Only Plaster Co. in Western Canada

Quality of goods superior to any imported article, our mill being equipped with the
latest improved machinery.
Dealers are invited to get our quotations before placing orders for Spring requirements

Office: 811 UNION BANK BUILDING, WINNIPEG

D. E. ROBERTS Lately in charge of the Plymouth
Plaster Co., at Fort Dodge, Iowa. **WM. MARTIN**
Superintendent of Manufacture General Manager

Moreau's Pulpwood Barking Machine

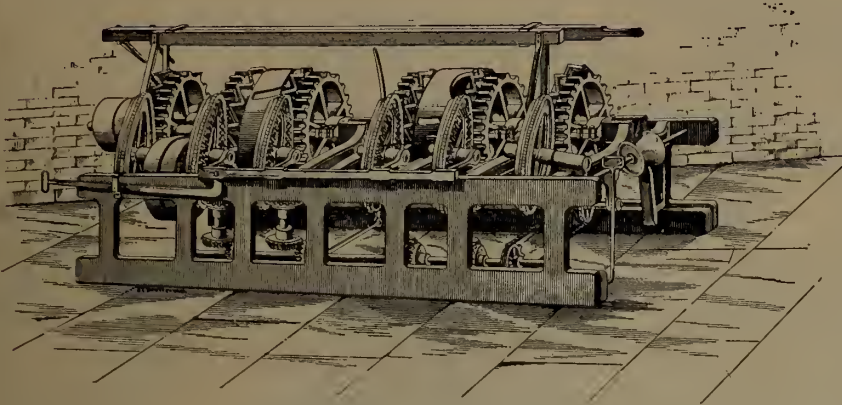

WEIGHT 4,200 LBS.

Latest and best Pulpwood Barking Machine. Requires about 7 h. p. to drive it full speed in work and one man can handle it and bark 22 to 30 cords of 4 foot wood per day according to average size of wood.

Wood is fed end on and any size from 3 to 24 inches, as the wood runs without loss of time between sticks. No long shavings and greatest economy in wood. Machines may be seen working any time. Write me for particulars.

R. S. P. SMYTH - QUEBEC, QUE.

Sole Agent for Canada

*P. O. Box 236
L. D. Phone 386*

THE E. LONG MANUFACTURING CO., ORILLIA, ONT.

THESE SAW CARRIAGES ARE MADE OF CAST STEEL, AND OPEN 36 TO 54 IN. FROM SAW.

We build Double Edgers, Steam Feeds, Log Jacks, Live Rolls, Trimmers, Slab Slashers, Steam Niggers.

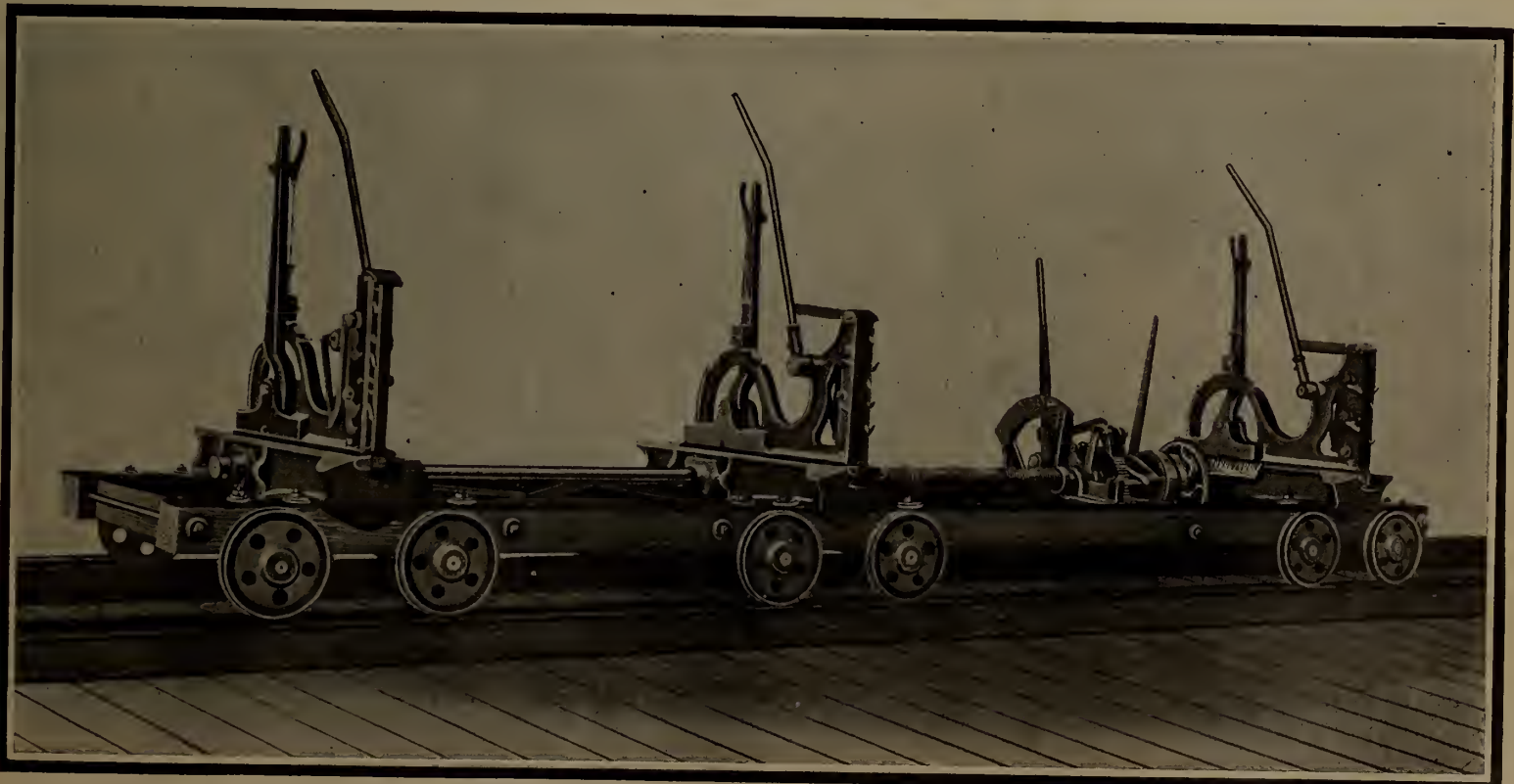

COMPLETE LINE OF SAW AND SHINGLE MILL MACHINERY
WRITE FOR CATALOGUE AND PRICES

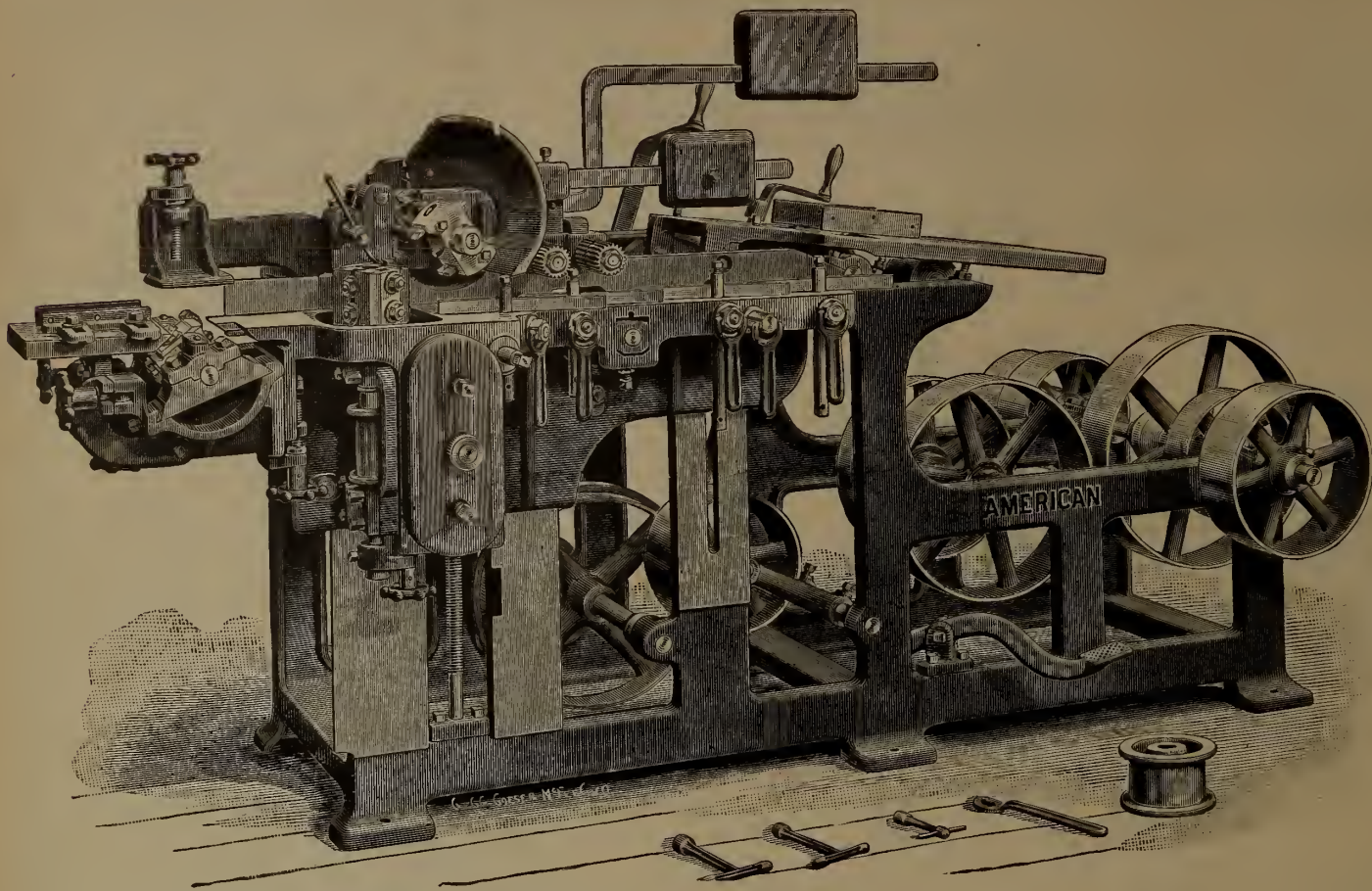

AMERICAN

No. 2 1/2
 Sash
 Sticker
 with
 Double
 Plowing
 and Boring
 Attachment



AMERICAN

No. 5
 Double
 Door
 Sticker



Ask
 For
 Catalogue

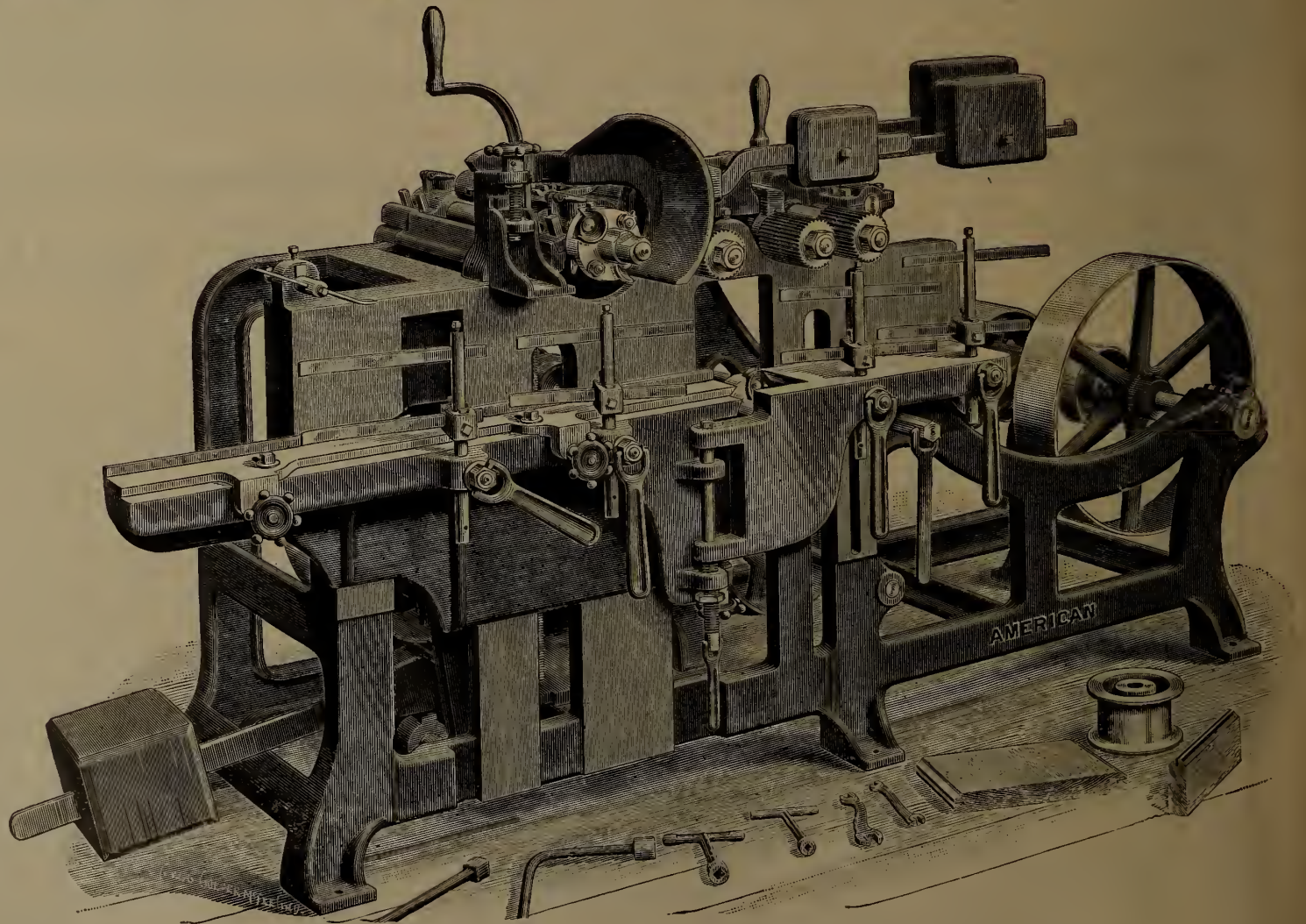

Address

AMERICAN WOOD WORKING MACHINERY CO.

136 LIBERTY STREET, NEW YORK

Sales Agent: **CANADIAN FAIRBANKS COMPANY, MONTREAL**

R. H. SMITH CO., LIMITED

— St. Catharines, Ont. —

We are the Sole Manufacturers of Saws
under the

Simond's Process

in the Dominion of Canada.

There is no process its equal for tempering circular saws. Other makers recognize this fact, as some of them, in order to sell their goods, claim to have the same process. All such Claims are FALSE, as the patentee in the U. S. and ourselves are the only firms in the world who use it.



INSERTED TOOTH SAWS

Notice the improved shank. We call particular attention to the swell which strengthens it at the weakest part and which gives it more wear than the old style.

Shanks made in usual gauges and to fit your saws perfectly.

SHINGLE SAWS

The quality of the "Simonds" Shingle Saws is proven by the fact that the largest shingle and machine manufacturers in Canada are using them.

Run a "Simonds" and you will increase your output.



CROSS-CUT SAWS

THE "NARROW LEADER"
REFINED SILVER STEEL.

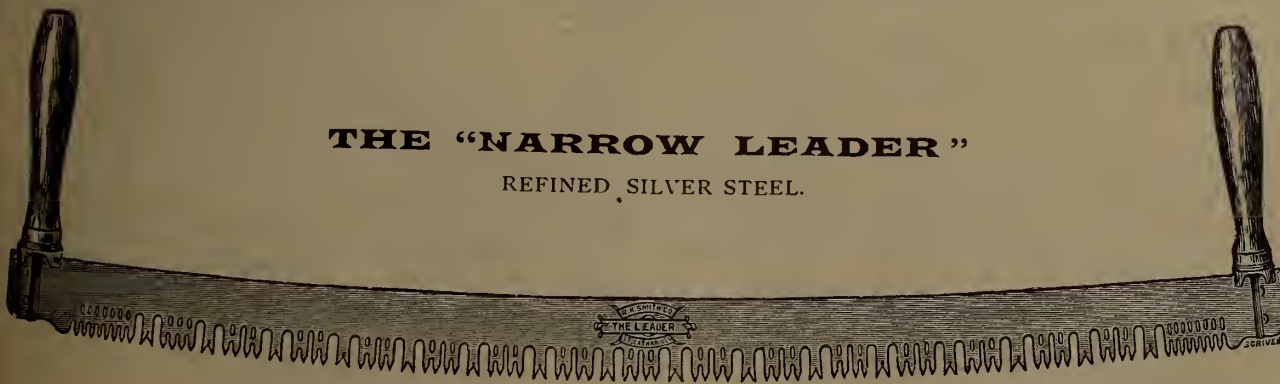

The Simond's temper and style of tooth make the "Leader" the fastest and easiest cutting saw manufactured.

Write for prices.

R. H. SMITH CO., Limited, St. Catharines, Ont.

CLASSIFIED INDEX OF ADVERTISERS

AXES
Dundas Axe Works. 40
ALLIGATOR TUGS
West & Peachey. 6
BELTING
Canadian Fairbanks Co. 3
Dominion Belting Co. 37
Gutta Percha & Rubber Mfg. Co. 41
Goodhue & Co., J. L. 1
McLaren, D. K. 1
McLaren Belting Co., J. C. 44
Waterous Engine Works Co. 37
Wilby, P. H. 12
Young, J. S. 1

BABBITT METALS
Syracuse Smelting Works. 44

BOILERS
Dyment Foundry Co. 36
John McDougall Caledonian Iron Works 35

DOORS
New Century Refrigerator & Mfg. Co. 10

DRY KILNS
Andrews Co., The A. H. 43
McEachren Heating & Ventilating Co. 43
Sheldon & Sheldon. 43
Standard Dry Kiln Co. 43

ELEVATING AND TRANSMITTING MACHINERY
Perrin & Co., R. 12

EMERY WHEELS
Hart Corundum Wheel Co., Limited. 30

ENGINES AND LOCOMOTIVES
Dyment Foundry Co. 36
Gartshore, John J. 10
Owen Sound Iron Works. 41
Robb Engineering Co. 38

EDGERS
DeLoach Mill Mfg. Co. 11
Gordon Hollow Blast Grate Co. 38

GRATES
Gordon Hollow Blast Grate Co. 38

LUMBERMEN'S SUPPLIES
Beal Leather Co., R. M. 32
Barr, Alex. 12
Capstan Mfg. Co. 37
Johnson, A. H. 38
Park, Blackwell Co. 40
Rice Lewis & Sons, Limited. 44
Thompson Mfg. Co. 32
Tobin, Joshua. 30
Woods, Limited. 1

LUMBER AND SHINGLE MANUFACTURERS
Bowman Lumber Co. 6
Cook & Bro. Lumber Co. 5
Canadian Pacific Lumber Co. 22
China Creek Lumber Co. 5
Crows Nest Pass Lumber Co. 4
Columbia River Lumber Co. 4
East Kootenay Lumber Co. 5
Fernie Lumber Co. 4
Ladysmith Lumber Co. 5
Mayook Lumber Co. 35
North Star Lumber Co. 4
Pigeon River Lumber Co. 5
Ross Bros. & Co. 5
Staples, Otis. 4
Yale-Columbia Lumber Co. 4

LUMBERMEN'S TOOLS
Baldwin, Tuthill & Bolton. 41
Burton Saw Co., A. J. 40
Hay Knife Co., Peter. 22
Pink, Thomas. 44

LUMBERMEN'S AGENTS
Friel, H. J. 37
Wright, H. J. 37

MISCELLANEOUS
Alexander Engraving Co. 32
Bradstreets. 10
Canadian Office & School Furniture Co. 10
Denton, Dunn & Boultsbee, Barristers. 6
Fielding, J. S., Consulting Engineer. 1
Georgian Bay Engineering Works—Grinders. 43
Huther Bros.—Dado Heads. 44
Lumber Mutual Fire Insurance Co. 34
Midland Engine Works Co.—Tram Car Wheels. 12
Mitskhun Co., M.—Car Movers. 32

Monteith, Nixon & Ch.—Trucks. 32
Manitoba Gypsum Co.—Plaster. 36
Spence & Co., R.—Files and Rasps. 11
Saw Gummer, A. T. McLatchie. 6
Sessenwein Bros.—Rails. 31
Toledo Fire Insurance Co. 33
Vogel, C. H.—Pulp Mill Engineer. 35

OILS
Commercial Oil Co. 37
Canadian Oil Co. 22
Queen City Oil Co. 11

PROVISIONS
Eckardt & Co., H.P. 29

PORTABLE SAW MILLS
Drake, F. J. 36
Owen Sound Iron Works. 41

PLANERS AND MATCHERS
Cowan & Co. 3

PULLEYS
Canadian Fairbanks Co. 3

PACKING AND PIPE COVERING
Garlock Packing Co. 12
Purvis Co., E. L. 37

ROPE
Canadian Cordage Co. 6
Consumers Cordage Co. 34
Dominion Wire Rope Co. 12
Greening Wire Co., B. 1
Mussen & Co., W. H. C. 1

ROOFING
Bird & Son, F. W. 32

RE-SAWS
Cowan & Co. 3

SAW SWAGES
Hanchett Swage Works. 31

SAW CAUCES
Specialty Mfg. Co. 12

STEAM BOILERS
Canada Foundry Co. 12
Owen Sound Iron Works. 41

SAWS
Atkins & Co., E. C. 28
Burton Saw Co., A. J. 40
Burns Saw Co., E. R. 1
Hoe & Co., R. 39
Shurley & Dietrich. 9

SAW MILL MACHINERY
Allis-Chalmers-Bullock. 3
Gordon Hollow Blast Grate Co. 38
Hamilton Mfg. Co., Wm. 2
Jenckes Machine Co. 35
Kendall, I. N. 41
Long Mfg. Co. 7
Lloyd Mfg. Co. 34
Manitoba Iron Works. 34
Mowry & Sons, B. R. 39
Owen Sound Iron Works. 41
Petrie, H. W. 1
Payette & Co., P. 34
Smart-Turner Machine Co. 44
Waterous Engine Works Co. 42
Williams, Madison. 11

SHINGLE MILL MACHINERY
Drake, F. J. 36
Long Mfg. Co., E. 7
Owen Sound Iron Works Co. 41
Williams, Madison. 11

STOVES
Hall, Adam. 39

TURBINES
Williams, Madison. 11

TRIMMERS
DeLoach Mill Mfg. Co. 11
Gordon Hollow Blast Grate Co. 38

WOODWORKING MACHINERY
American Woodworking Machinery Co. 8
Connell & Dengler Machine Co. 38
Cowan & Co., Limited. 3
Dodge Manufacturing Co. 10
Defiance Machine Works. 6
Perkins & Co. 40
Rogers Iron Mfg. Co. 37
Sherman Co., W. S. 38
Shimer & Sons, Samuel J. 40
Waterous Engine Works Co. 42

The ... QUEEN CITY OIL CO. LIMITED
Head Office: TORONTO.

HIGHEST GRADES OF Refined Oils Lubrication Oils AND ALL Petroleum Products

CANADIAN OFFICE & SCHOOL FURNITURE CO. LIMITED
FINE BANK OFFICE, COURT HOUSE & DRUG STORE FITTINGS. OFFICE, SCHOOL, CHURCH & LODGE FURNITURE. PRESTON ONT. SEND FOR CATALOGUE.

ESTABLISHED 1849. BRADSTREET'S Capital and Surplus, \$1,500,000. Officers Throughout the Civilized World. Executive Offices: Nos. 346 and 348 Broadway, New York City, U.S.A. THE BRADSTREET COMPANY gathers information that reflects the financial condition and the controlling circumstances of every seeker of mercantile credit.

RAILS For Logging Tramways, Switches, Etc. New and Second-Hand. YARD LOCOMOTIVES John J. Gartshore 83 Front St. West, (Opposite Queen's Hotel), Toronto.

R. SPENCE & CO. Beech File Works. HAMILTON, ONT. FILE AND RASP MANUFACTURERS AND RE-CUTTERS. A trial order solicited. Write for price list and terms. C. P. MOORE, PROPRIETOR.

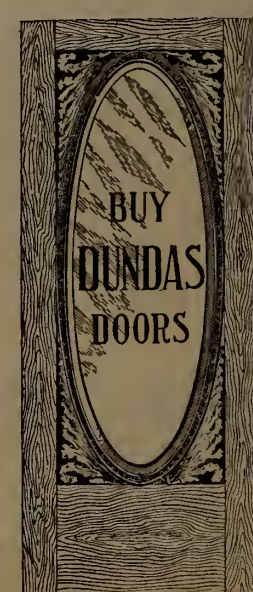

New Century Refrigerator & Manufacturing Co., Limited Dundas, Ont., Can.

Our Business is Manufacturing HARDWOOD VENEER .. DOORS With Built Up Bodies

These Doors are guaranteed not to warp or twist and are superior in construction and finish to any other Door on the market. Send for Illustrated Catalogue and Prices. Special attention given to Architects' Designs of Doors and Trims. AGENTS WANTED EVERYWHERE. ADDRESS DOOR DEPARTMENT

DE LOACH PATENT SAW MILLS AND HIGH GRADE MILL MACHINERY



We manufacture Saw Mills, single and double, all sizes and for all purposes.

OUR NEW "MONARCH" Saw Mill with one saw does the work of a double mill. A new and very interesting feature.

GANG EDGERS, five sizes with variable friction feed, three sizes with three rolls driven.

LUMBER TRIMMERS, three sizes with variable friction feed, and reversible power attachment for operating the head blocks.

LOG HAULS and Logging Machinery, Live Rolls and Log Turners, all of entirely new design, with variable friction and worm gear drive.

SHINGLE MILLS, three kinds, two with automatic variable friction feed, also hand feed.

Lath Mills, Stave Mills, Grinding Mills, Baling Presses, Turbine Water Wheels, Mill Gearing, Shafting, Pulleys, Hangers and Power Transmission.

Write for 144 page Catalogue.

DeLoach Mill Manufacturing Company, Box 509, Atlanta, Ga.

THE TRIUMPH TURBINE



Is the most powerful wheel on the market to-day. A glance at this cut of the centre shows that the buckets are designed to secure the **maximum of speed** with **great power** and a **free discharge**. Mr. E. S. Edmondson, of Oshawa, writes as follows under date of November 16th, 1903, regarding a 26 inch Vertical Triumph Wheel:

"The Wheel is strictly first-class in every particular, and after a careful and thorough test I am prepared to say that I believe it is the best wheel in the market for Electrical purposes. It has high speed, large power, high efficiency at part gate, and has practically no leakage. I am more than pleased with the thorough and workmanlike setting you gave me throughout."

For horizontal settings in large Pulp Mills, Cement Mills or Electric Power I developments this Wheel has no equal. We invite your enquiries. Large catalogue to be had for the asking.

We are always glad to submit estimates and prices on **Improved Vulcan and Leffel Turbines, Improved Lane Circular Saw Mills, Edgers, Trimmers, Slashers, Shingle Machines, Lath Machines** and all machinery of this kind.

MADISON WILLIAMS

H. E. PLANT, Agent
Cor. Common and Nazareth Streets
Montreal, Que.

Successor to Paxton, Tate & Company
PORT PERRY, ONT.

Manitoba Iron Works
Western Selling Agents
Winnipeg, Man.

TEON BELTING



STEAM PROOF
WATER " "
HEAT " "
OIL " "
ACID " "

Stronger and Cheaper than Leather.

LEATHER BELTING
CAPATA BELTING [BALATA TYPE]

CAMELS HAIR BELTING
LACE LEATHER, ETC.

Special Arrangements for Trial 'elts.
Write for Price Lists and Discounts.

P. H. WILBY, 27 1/2 Front Street East, TORONTO
SOLE AGENT FOR CANADA.
Phone Main 1930.

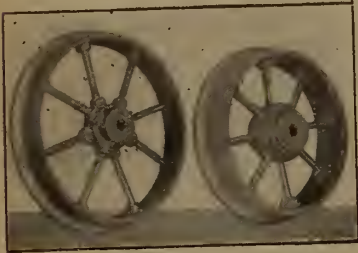

Our special Tram Car Wheels

made from a special mixture of Iron, are stronger, longer lived, low in price and lighter for their strength than any other wheel. Write for prices and samples of metal.

MIDLAND ENGINE WORKS CO.
MIDLAND, ONT.

LARGE STOCK CARRIED & CUT TO ANY LENGTH
BLOCKS, CLIPS, TURNBUCKLES, ETC.

WIRE ROPE

SPECIAL ROPES FOR LUMBERING
DOMINION WIRE ROPE CO., LTD
MONTREAL, QUE.

EVERY LUMBERMAN WANTS IT — 35 cents buys it
Scribner's Lumber and Log Book

BRIMFUL OF EVERY-DAY PRACTICAL INFORMATION

Address: THE CANADA LUMBERMAN, Toronto

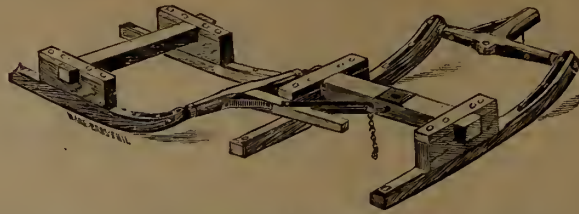

THE LUMBERMEN'S FRIEND

(Desjardin's Patent)
ALSO

Heavy Runners for Logging Sleighs Bent to Order, Poles, Beams, Rollers, Blocks, and other parts on hand at all times.

I ALSO MAKE
Boom Chains
Logging Chains
Skidding Tongs
Clevis' Heavy
Neckyokes and
Whiffletrees

Large
DUMPING WAGONS
for Mill Yards a
Specialty

ALEX. BARR

WRITE FOR PRICES Manufacturer Pembroke, Ont.

Detachable Chain Belt

—AND—

CONVEYING

MACHINERY



William R. Perrin & Company Limited

TORONTO, CANADA.

WOODWORKERS SAY
"The convenience to the Sawyer and the saving in lumber make the STANDARD AUTOMATIC SAW GAUGE an article of much merit."
WRITE TO SPECIALTY MFG. CO. DETROIT Mich.

Garlock Packing Co.

HAMILTON - - - CANADA

—SOLE MANUFACTURERS OF—



GARLOCK'S PACKINGS

PATENTED

Asbestos and Mineral Wool Pipe and Boiler Coverings, Engineers' Supplies in General

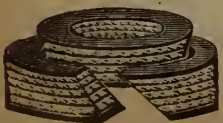

THE CANADA LUMBERMAN AND WOOD-WORKER

VOLUME XXV.
NUMBER 7.

TORONTO, MONTREAL — AUGUST, 1905 — WINNIPEG, VANCOUVER

TERMS, \$1.00 PER YEAR
Single Copies, 10 Cents

HON. ADELARD TURGEON,

Minister of Lands, Forests and Fisheries, Province of Quebec.

By BYRON NICHOLSON.

The history of the Hon. Adelard Turgeon, the present Minister of Lands, Forests and Fisheries in the Province of Quebec, is significant and instructive as indicating the rapidity and moral certainty with which a man of brilliant parts and close application to business may rise to honor. Even in Canada, where it is made a perpetual boast, and not without reason, that the way to distinction is open to deserving effort in any rank of life, upward progress so rapid as that of the subject of this sketch is at once rare and noteworthy.

The Hon. Mr. Turgeon is a son of Damase Turgeon, farmer and trader at Beaumont, Bellechasse County, Quebec, and was born on December 19, 1863. He was educated at Levis College and Laval University, at which latter institution he graduated, taking honors both in letters and in law. He was called to the Bar in 1887, and it was not long before he took a prominent place in his profession. He commenced practice in Levis, where he was at the time a resident, but afterwards moved to the city of Quebec, and entered into partnership with the Hon. H. G. Carroll, now judge of the Superior Court. In a short time he became the senior partner in the well known firm of Turgeon, Lachance & Ahern.

The rising lawyer naturally looks to the Legislature as affording him the best and highest chances of success, and in 1890 Mr. Turgeon successfully contested Bellechasse, being returned by an overwhelming majority over an exceptionally strong opponent. He has continued to represent that constituency ever since, and his popularity is seen in the increase of his majority at each election. A ready eloquence, a striking personality, a popular man in the broadest sense of the word, combined to make him one of the most influential members of the Legislature, and very valuable to his party. Hence it came to pass that when in 1897 the late Premier Marchand came into office it was a foregone conclusion that Mr. Turgeon, standing so high in repute as a practical official, a lawyer and a public man, should be recognized for preference. He was appointed Commissioner of Colonization and Mines, and the wisdom of this appointment was more than justified by the conspicuous ability with which he discharged the duties of this important office. Upon the reorganization of the Provincial Cabinet under the Premiership of the Hon. S. N. Parent, in 1900, Mr. Turgeon accepted the portfolio of Provincial Secretary, the onerous duties of which office he continued to discharge

with exceptional promptitude and ability until 1902, when he was promoted to the portfolio of Minister of Agriculture in the same Administration.

Hon. Mr. Turgeon is a fluent speaker, and is equally felicitous in both French and English. At a banquet tendered to him recently in the city of Quebec in recognition of his decoration as a Knight of the Legion of Honor of France, and also as an officer of King Leopold's Order (Belgium), he made eloquent reference to the happy manner in which the affection of French-Canadians for the land of their sires



HON. ADELARD TURGEON.

had become reconciled with loyalty to the British Empire. "Thanks be to God", the speaker exclaimed, "this has been brought about by the superior political sense of our statesmen, by the moderation of our English fellow-countrymen and by the sagacity and patriotic foresight of the representatives of the mother State, by such men as Lord Elgin, Lord Dufferin, and the Marquis of Lorne".

Hon. Mr. Turgeon, married in July 1887, Miss Eugenie Samson, daughter of Etienne Samson, Levis, Que. He is a member of St. James' Club, Montreal, and the Garrison Club and the Canadian Club, Quebec, and is a patron of several local athletic clubs, being himself an athlete of no mean order.

Mr. Turgeon is now at Liege, Belgium, in the capacity of Canadian Commissioner to the Exposition being held at that place.

The exports of forest products from Canada during the fiscal year ending June 30th, 1905, were valued at \$33,235,683, as compared with \$33,091,992 for the previous year.

POINTS ON SAW FILING.

The filing of the saw embraces so many points that each one is worthy of distinct mention and suggestion. Every effort should be made to have the teeth all alike in shape and length, the length being governed by striking off the saw frequently while running and just before filing or changing, both for keeping the saw in balance and to have each tooth do its share of the work. Sometimes a tooth or several teeth are broken off in a saw, and in that case it is advisable to keep the stub of the tooth pointed and set just as if it were cutting at the point, only the point should not be filed or gummed until the other teeth have been worn down far enough to let the shorter teeth do part of the work at the point. By keeping the teeth set the work is made smoother and there is not apt to be a ridge or lump left in the sawing at each turn of the saw.

Then there is the dressing of the points of the teeth, for no filer thinks of filing the teeth to shape, as cheap as emery wheels are and as rapidly as the work can be done with them. A file should be used its entire length from heel to point, and the dragging of the file on the return stroke should be avoided carefully, though this is a rule more honored in the breach than in the observance. To handle a file in this way accomplishes two things desirable in saw filing; it saves the files and it enables the filer to file a straight face to a tooth that helps in keeping a saw in good condition. To allow a file to waver in its course and to take short strokes shows on the work and leaves a tooth with a number of faces to it, no one of which may be the correct one for the work to be done. It is an indication of inexperience or carelessness to hear a filer making a noise like a wheelbarrow that needs greasing when he is drawing a file back over his work.

It should be borne in mind that when a saw fails to do the work for which it is intended, it is the result of some neglect of the plain laws governing its care, for all machinery needs care to keep it in its proper condition, and as with the members of the human family, the doctor is often needed to repair before the final dissolution. There are so many ways in which there are losses to heading, that to have the loss begin at the saw is like throwing good money into the street. With a saw, new and as thin as 18 gauge at the rim, machine in good condition and saw sharp, with ample power, we have still enough openings after this for the heading to drop through not to want to keep this end of the work in perfect shape. When the saw wears down some, and we find we are throwing too many inches of good lumber into the dust pile, it is time to change for a thinner saw. Saw steel is cheaper than good heading in a case of this kind.—Packages.

PIT SAWING.

Mr. William F. Fox, in his "History of the Lumber Industry of the State of New York," gives some interesting particulars regarding the beginning of lumbering and pit-sawing.

The evolution of the sawmill, he says, is largely due to the conditions and demands of the lumber industry in America. The early colonists built and operated sawmills one hundred years or more before there was one in England. This method of manufacturing was not, however, absolutely necessary. The wainscotings,

wedge, could easily supply his few wants in this respect; but in the villages which sprang up at each important trading post there was a demand for building material and ship-timber which the villagers themselves could not well supply. Most of them were engaged in better paying pursuits or professions; hence, some labor found employment in manufacturing lumber by hand-power. The large timbers for house and ship building were hewn out and squared with a broadax by men who were experts with this tool. The planks, boards, and

(see illustration.) The workman on top, who guided the saw along the chalk line, and who was supposedly the better man, was called the top-sawyer. The one below was called the pit-man. When sawmills were first substituted in this work the saw was held taut on the upward stroke by a spring pole overhead, and was worked up and down by a wooden beam attached to a crank on the mill wheel. This wooden beam was called the pitman, and is still known by that name in every sawmill throughout the country. Pit-sawing or whip-sawing, as it is often called, was not entirely abandoned on the introduction of sawmills. This old method was still useful in sawing long stuff, because in many mills the log-carriage was not long enough to saw planks of the desired length. As late as 1860, at the gang-mills near Painted Post, Steuben County, the writer saw a large, square stick of timber being sawed in this fashion into long planks for the sides of a canal boat.



PIT SAWING.

paneled ceilings, cabinetwork, and Chipendale furniture which made famous the stately homes of England were constructed in all their perfection long before the first sawmill was erected in that country. The men who founded the Massachusetts Bay Colony, together with the emigrants who followed them for a hundred years, had never seen a sawmill in their native land. So, if a sawmill did not always appear in a colony soon after the first settlement, it does not follow that no lumbering was carried on. They had other means of manufacturing the forest products.

The pioneer of the wilderness, with axe and

boat sides were mostly made by pit-sawing. The latter was a common industry in the old country; and one reason why England had no sawmills until after 1768 was because the mobs, always opposed to labor-saving machinery, destroyed the first ones as fast as erected through fear that the pit-sawyers would be thrown out of employment.

Pit-sawing was done by two men with a long saw that had cross handles on each end. A stick of timber, hewed square, was placed over a pit, or elevated on trestles. One man stood on top of it and pulled the saw up, and one man stood in the pit below to pull the saw down.

QUARTER-SAWING IN SMALL MILLS.

Since most of the methods of quarter-sawing that have been advocated in these columns seem to be from parties identified with large mills, I give one which may interest the small mill man, who doesn't possess all sorts of money and tools and must make out with what he has.

Suppose we have a 50 or 52-inch single saw

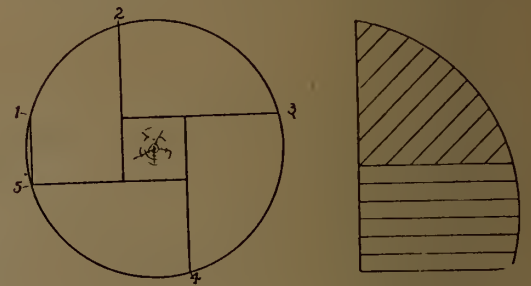

FIG. 1.

FIG. 2.

and want to quarter-saw a log as large as, say, 33 to 35 inches. Some five-dollar-a-day men might say they would not run such a plant. I presume that is because they don't have to; others, however, do. I am not an expert sawyer, know nothing about a band saw, and for what sawing I have to do will take the old circular, as there are not so many cracks to deal with.

Referring to the sketch, line 1 is to take off a light slab. Line 2 is run in as near the heart as practicable and not strike heart defects. It will be understood that the saw will cut but a few inches above center. When these two lines are run, turn log one-quarter over, toward headblocks, until first line is level or at right angle to saw. Now run line 3 near centre, like line 2, and flitch will drop out. Turn log one-quarter over again, until line 1 will lie flat against knees. Now run line 4, turn, and run line 5. The log will now be in five pieces, including heart. Rip up flitch the usual way. Most of the log will be quartered. The bark corners of flitch can be turned bark down and also quartered, like Fig. 2. I sometimes take off light slabs to save edging.—W. C. Hancock, in the Woodworker.

NEW BRUNSWICK LUMBERMEN'S ASSOCIATION.

The New Brunswick Lumbermen's Association held its annual meeting at St. John on July 26th. Those present included: Arthur Hilyard, Dalhousie; T. M. Burns and Frank Curran, Bathurst; James Beveridge, W. B. Snowball and R. A. Lawlor, Chatham; Fred Sumner, Moncton; J. D. Irving, Buctouche; F. M. Anderson, St. Martins; D. D. McLaren, Fred. E. Sayre, C. P. Baker, W. C. Purves, Geo. McKean, W. E. Golding, N. H. Murchie, and Henry Hilyard, St. John; G. A. Murchie, St. Stephen.

A committee consisting of W. B. Snowball (convenor), George McKean, Henry Hilyard, T. M. Burns, J. D. Irving and N. H. Murchie, was appointed to wait upon the local government in September and press upon them the claims of the lumbermen of the province for an extension of the existing leases of license holders, a reduction of the mileage, the necessity for a better regulation respecting the selection of licensed lands nominally for agricultural purposes, and other matters.

Respecting the extension of the leases, most of which are due to expire in about ten years, the lumbermen say that inasmuch as they have to the present time been judiciously operating on the timber lands, cutting where the timber is fully grown and not destroying the younger tracts, it would be of advantage, not only to the lumbermen themselves, but to the province generally, that an extension of existing leases be granted so that it will be unnecessary for them to cut down within the next few years the timber that, because it is not fully grown, ought not to be cut within the life of the leases. This they would naturally do unless they are willing to bid high prices against speculators when the lands next come to be let. If an extension is granted, they say, the young forests of the province will be more economically preserved.

They believe that the government is willing to take into consideration the expense the lumbermen have undergone in the erection of mills, dams and booms, and grant an extension of at least a portion of these leases.

Another matter that will be urged upon the government is the exercise of greater care in the granting of lands for settlement. They say there have been cases where men, upon making a deposit of \$3, took out, nominally for settlement, valuable timber tracts having in view the acquisition of the timber only, and not for farming. There is a great deal of land in the province, the lumbermen claim, suitable for settlement, and it is not necessary to give away valuable timber land in this way. Obviously, they hold, if a man desires a grant for farming purposes, it is not his honest policy as a farmer to first go into the forest and begin operations upon timber land, when there is land for him in New Brunswick that is practically cleared. They hold that a good deal could be done by the government, among other things, in securing for him the abandoned farms, and their contention is that, by the process that is complained of, he frequently gets timber lands at homestead rates.

The association will also make another

attempt for a reduction of the mileage which, without any consultation with them, they say, in the matter, was recently advanced by the government from \$4 to \$8 a mile.

The following executive committee was chosen:—President, W. B. Snowball, Chatham; vice-president, Geo. McKean, St. John; secretary, R. A. Lawlor; Kilgour Shives, Restigouche; T. M. Burns, Gloucester; Hon. Allan Ritchie, Northumberland; J. D. Irving, Kent; F. W. Sumner, Westmoreland; C. T. White, Albert; Henry Hilyard, St. John; J. A. Gregory, Charlotte; S. H. White, Kings; Fred E. Sayre, Sunbury; Mr. Baker, York; M. Welch, Carleton; T. Lynch, Victoria; John E. Moore, Madawaska.

Applications from fifteen lumbermen for admission into the association were received and accepted.

The next meeting will be held in Moncton on the first Tuesday in July.

UNIQUE STEAM LOG HAULER.

The accompanying illustration will give the interested reader a clear idea of a steam log hauler used by some of the progressive lum-

bermen of the Northwest for facilitating the long-distance hauling of logs. It is used in localities where the distance which the timber must be transported in order to reach desired streams or railroads is so great as to prohibit its being hauled by teams profitably.

bermen of the Northwest for facilitating the long-distance hauling of logs. It is used in localities where the distance which the timber must be transported in order to reach desired streams or railroads is so great as to prohibit its being hauled by teams profitably.

The construction of this steam log hauler involves an adaptation of the general principles of the ordinary geared locomotive, suitable wheels especially constructed for the purpose taking the place, on the axle, of the main driving wheels. These wheels are covered with an endless chain or sectional metal belt which is forced to revolve by the revolution of the driving sprocket wheels. The greater portion of the weight of the boiler and locomotive rests on the revolving sections of the metal belt, which are armed with teeth or calks, these being set into the sections transversely. The calks are driven into the ice road by the weight of the machine, thus giving the hauler its traction or friction power for starting and keeping the heavily loaded sleds in motion. The front end of the hauling engine rests on the center beam of a movable sled, which is so constructed that it will run

forward or backward, and may be turned in any desired direction by the man piloting the hauler, with a lever purchase wheel similar to the guiding wheel on an automobile or an ordinary brake wheel on a car. The hauler is not confined to forward motion alone, but can be reversed as quickly as any locomotive of this type, and may be guided by the runner sled into any desired position. That it is a practical success has already been demonstrated. The rate of speed which can be maintained with a load of trailers (coupled log sleds) is from five to seven miles an hour. It is confidently expected that this hauler will be able to handle ten pairs of loaded log sleds on each trip when the roads are in good condition, each pair of sleds carrying 10,000 feet of logs B. M. (log scale).

The hauler shown in the illustration was constructed for the Northland Pine Company for use on their own operations, and is at the present time being used by them to haul the logs and timber from three of their lumber camps on the former Chippewa Indian Reservation, in Minnesota, to Pine River, a tribu-



STEAM LOG HAULER USED IN MINNESOTA.

tary of the Mississippi. This is an eight-mile trip each way, on which it is expected to make four round trips each day of twenty-four hours.

One of the advantages claimed for this machine is that it does not get tired nor have to stop to rest, a change of the operating crew being all that is necessary to keep "the bull of the woods" moving night and day. Another advantage is that on the return trip to the woods with the empty sleds, when its load is the lightest, the hauler pulls its sprinkling tanks loaded with water for icing the log road, also its rut cutter for clearing out and deepening the rut in which the sleds run, thus practically keeping its track or roadbed in condition for constant use, without any additional help, other than the regular crew working with the hauler. It will be readily understood by the experienced lumberman that this steam hauling device economizes largely in the cost of team hire, which is one of the heaviest expenses of a lumber camp, especially where the haul is long. Besides it gives the operator a chance to use his teams in skidding and in hauling the loaded trailers from the short branch roads out to the main log road, over which the steam hauler passes on its regular trips to and from the landings. —Eugene S. Bruce, in *Forestry and Irrigation*.

THE Canada Lumberman AND WOOD-WORKER

(Monthly and Weekly Editions—One Dollar Per Year.)

PUBLISHED BY

The C. H. Mortimer Publishing Company
of Toronto, Limited,

CONFEDERATION LIFE BUILDING, TORONTO.

BRANCH OFFICES:

38 ALLIANCE BUILDING, MONTREAL.
720-721 UNION BANK BUILDING, WINNIPEG.
22 GREAT ST. HELENS, LONDON, E. C.
536 HASTINGS STREET, SUITE 3, VANCOUVER, B. C.

The LUMBERMAN Weekly Edition is published every Wednesday, and the Monthly Edition on the 1st day of every month.

TERMS OF SUBSCRIPTION:

One Copy, Weekly and Monthly, One year, in advance, \$1.00
One Copy, Weekly and Monthly, Six Months, in advance, 50
Foreign Subscription, \$2.00 a Year
ADVERTISING RATES ON APPLICATION.

THE CANADA LUMBERMAN AND WOOD-WORKER is published in the interest of and reaches regularly persons engaged in every part of Canada in the lumber, wood-working and allied industries. It aims at giving full and timely information on all subjects touching these interests, and invites free discussion by its readers.

Special care is taken to secure for publication in the WEEKLY LUMBERMAN the latest and most trustworthy market quotations throughout the world, so as to afford to the trade at home and abroad information on which it can rely in its operations.

Advertisers will receive careful attention and liberal treatment. For manufacturing and supply firms wishing to bring their goods to the attention of owners and operators of saw and planing mills, wood-working factories, pulp mills, etc., the CANADA LUMBERMAN AND WOOD-WORKER is undoubtedly the most direct and profitable advertising medium. Special attention is directed to "WANTED" and "FOR SALE" advertisements, which are inserted in a conspicuous position on front page of the Weekly Edition.

OUR VANCOUVER OFFICE.

The publishers of this Journal have recently established an office in Vancouver for the purpose of looking after more carefully the interests of subscribers and advertisers in British Columbia. This office is located at 536 Hastings Street, Suite 3, opposite Molson's Bank, and is in charge of Mr. G. A. Gall, who will be pleased to meet any of the friends of this journal, and to serve their interests in any possible way.

BUILDING ACTIVITY.

The extent of building operations throughout Canada is this year greater, we believe, than in any other year in the history of the country. Remarkable activity has prevailed all season, not confined to any particular city or district, but extending from the Atlantic to the Pacific. Last year was a very good year for the building trade, but the figures for the first half make a very unfavorable showing when compared with the same period in 1905. The following returns of the value of building permits issued during the six months of the two years have come to our notice:

BUILDING PERMITS.

	1904.	1905.
Winnipeg	\$6,300,400	\$6,414,500
Toronto	2,625,883	4,494,326
Montreal	1,588,815	2,516,761
Ottawa	661,150	936,425
Hamilton	403,225	731,342

It will be seen that Winnipeg is experiencing a continuation of the building boom which was so pronounced last year. It is estimated that buildings to the value of upwards of ten million dollars will be erected in that city this season, thus exceeding the splendid record of 1904. Toronto, also, is the centre of exceptional activity, the permits reaching nearly double those of last year. While the complete figures are not before us for Vancouver, Victoria and other points in British Columbia, we are aware that building operations in the far west are quite extensive.

The prosperous condition of the building industry is naturally regarded in a favorable light by the lumber trade. It has been an influential factor in sustaining lumber prices, and is regarded as further evidence of the growing importance of the domestic market. But it is the most significant, perhaps, as reflecting the confidence which is everywhere discernible regarding the future of this country. And where such confidence exists, progress is almost certain to be made. The opinion is frequently expressed by the shrewdest of capitalists and business men that we are on the threshold of very rapid development and that Canada is destined to become a much greater country than she is. Sir Wilfred Laurier predicts that Canada will be to the twentieth century what the United States has been to the nineteenth. In the last two years we have received 255,000 immigrants, and there is every indication that our population will continue to grow even more rapidly for many years to come.

RELATIONS BETWEEN MANUFACTURER, WHOLESALE AND RETAILER.

The relations existing between the various branches of the lumber industry have not always been as harmonious as might be desired, nor is it likely that that condition will ever be reached when all will be thoroughly satisfied; but it should be quite possible, by the elimination of selfishness and the adoption of the principle "live and let live," to have the rights of each branch more generally recognized.

In again touching upon this much discussed question, it is not the intention to champion the cause of either the manufacturer, the wholesaler or the retailer, but rather to refer briefly to some of the things which have had a tendency to create dissatisfaction.

Unfortunately, some of the manufacturers are not yet disposed to recognize the wholesale dealer as a necessary factor in the lumber business. They seemingly regard him as being responsible for an unnecessary charge against production, represented by the difference between the wholesale and retail price. Most manufacturers, however, we are glad to say, take a broader view of the question and willingly give the wholesaler all reasonable opportunities. They recognize that the dealers have been instrumental in creating demand and in many instances have found new markets for lumber; also that the net price realized from the middleman is frequently greater than if the stock were sold on commission or travellers employed to dispose of it in a retail way.

The complaint is heard among mill men that many of the wholesalers insist on too many grades; they are not prepared to take blocks of mill run stock, but only such grades as meet the requirements of their particular customers. This condition, it is maintained, is responsible in part for the disposition to eliminate the wholesaler and sell direct to the retailer or consumer.

Now we come to the relations between the wholesaler and retailer, and it is only fair to say that both have grievances. Of paramount importance, perhaps, is the tendency of the wholesaler to enter the legitimate field of the

retailer. "Last year," said a Toronto retailer to the writer, "I gave a certain firm upwards of \$30,000 worth of business, but this year I am buying nothing from them for the reason that they have been selling direct to contractors." Against the retailers, it can be said that they are more reluctant to suffer loss through price fluctuations than the other branches of the industry. If between the time of placing a contract for stock and the delivery thereof the market should weaken materially, it is not uncommon for the wholesaler to be requested to make some allowance for the depreciation, and as the refusal of the request might mean the loss of the customer's future business, it is sometimes considered expedient to make some reduction in the price agreed upon. If such claims should be allowed, then equivalent allowances should be made to the wholesaler when prices advance in the intervening time before the stock is delivered. But would the buyer agree?

The pathway of lumbermen may be made smoother by fair dealing and just recognition of the rights of others.

SPRUCE FOR STREET PAVING.

Hardwoods have been used very largely in Great Britain for street paving, Australian karri being a favorite wood for that purpose. It has not, however, been found entirely satisfactory owing to the contraction which takes place in warm weather, due to the green state in which the blocks are laid, and which permits the ingress of road refuse and insanitary substances between the blocks.

At the present time, much attention is being given to spruce, which has heretofore been considered unsuitable for street paving on account of its refusal to absorb creosote. A process is believed to have been discovered by which softwoods can be solidified, toughened, and made practically non-absorbent, while the tendency to warp, contract or expand is reduced to the minimum. This will, it is believed, produce the ideal paving block, combining the full length of the life of hardwoods with the freedom from contraction and expansion found in softwoods. Green timber is preferred, and when treated it is said to have no tendency to fermentation and to resist the attacks of dry rot.

A section of spruce paving treated by the new process was constructed in Westminster and is reported to be in splendid condition. The blocks were cut from Quebec spruce planks 12 ft. by 9 in. by 3 in.

Canadian spruce manufacturers should take full advantage of this opportunity of widening the market for this class of timber, of which there is a plentiful supply.

NEW FOREST RESERVE.

The present Ontario Government is showing in a very practical manner that it is in sympathy with the policy of the late Government in establishing forest reserves, for an Order-in-Council has lately been issued creating a new reserve within a 20-mile radius of Lake Nepigon

THE LUMBERMEN'S CLUB OF OTTAWA.

The first annual convention of the Lumbermen's Club of Ottawa, which represents the leading workers in the lumber trade of the Ottawa Valley and the Georgian Bay district, was held in Ottawa July 19th, in their elaborate club rooms over the Royal Hotel. Their quarters presented a very cosy appearance, and were appropriately decorated with bunting, logging scenes, beautiful moose heads, bear skins, snow shoes, cross paddles and other articles typical of the life in the woods; in fact, everything was done in keeping with the Club's personnel, which includes many of the most influential citizens of the Capital.

A large number of members from various points arrived during the morning. The members met at 2 o'clock and the afternoon was spent in a car ride to Britannia on specially reserved cars, returning later through the city to Rockcliffe, where a sumptuous repast was served at the "Royal Shanty," the building erected on the occasion of the visit of the Duke and Duchess of York a few years ago and where they enjoyed their first "snack" of lumbermen's pork and beans.

The lumbermen took great enjoyment out of their ride in and about the Capital. They are sturdy, hearty fellows who know thoroughly how to work and how to enjoy themselves when their work is done. In the woods they are foremen, cullers, book-keepers, clerks and men who have shown themselves to be possessed of ability, education and reliability enough to hold positions of trust. Seldom could one see gathered together a stouter, healthier and more genial band of typical Canadian manhood. They represent a type that has made the country and to-day is pushing its prosperity to the front rank of nations.

An interesting fact in connection with the lumbering industry was that Mr. Hamilton McCarthy selected from the members one to serve as a model for the statue representing the lumbering industry to be erected on the driveway. He selected Michael Barrett, foreman for Alexander McLaren. He is a man of magnificent physique.

The business proper of the convention was transacted in the evening session, and was ably conducted by Mr. Wm. Burns, who occupied the chair. He spoke in part as follows:—"It affords me very great pleasure at this our first annual meeting, to welcome you to our hearts, our homes, our city and our club rooms. It is a source of gratification to those of us who have undertaken the formation of this Club to see that our efforts have not been in vain. While we are pleased to see so many, we regret that some whom we would liked to have met, are not able to be present by reason of their duties and illness. We have also reason to feel gratified that though only in our infancy, we have been able to enlist the help and good wishes of most of those who are prominent in the lumber industry in the Ottawa Valley. A considerable expense has been incurred during the past year, but we have been able to finish the year with a considerable balance to our credit. Our objects are purely

social, to meet one another and to help each other in any way we can. We would be pleased to see any of the members at any time and extend to them and their friends a cordial invitation to make use of the rooms and appurtenances any time they are in town and have time to drop in. The reports of last year will be laid before you and we trust that they will meet with your approval."

The Secretary, Mr. Ernest Pitt, then made his report. He stated that the total receipts during the year were \$324 and expenditure \$119.01, leaving a balance on hand of \$205.99.

The Auditors, Mr. W. H. Rice, Mr. Archie McAdam and Mr. H. S. Brock, reported having found the books in a very satisfactory condition and commended Mr. Pitt very highly for his faithful and capable work. Mr. Brock, speaking for the auditors, said that with his two associates he had audited the books and found them in a very peculiar condition, with \$8 too much to the credit of the Club, and he thought the Club should pass a hearty vote of thanks to Mr. Pitt for the care he had taken and the valuable time he had expended on the work, which was accordingly done.

It was moved by Mr. Smith and seconded by Mr. Rice that the Secretary's report be adopted, which was carried unanimously.

It was moved by Mr. W. H. Rice and seconded by Mr. James T. Leslie that the annual convention should hereafter be held on the third Wednesday of July in each year, which motion was carried.

The Chairman asked the opinion of the meeting as to the admission of honorary members. At the inaugural meeting it was decided to admit only one honorary member of each profession, but this had not proved quite satisfactory and it was moved by Mr. H. S. Brock and seconded by Mr. W. A. Cameron that any eligible party be allowed to join the club as honorary member, the admission to join being made subject to a vote of the members of the Club. The membership fee in all cases to be \$2 per year.

It was proposed that the annual fee be raised from \$2 to \$3—two dollars to go towards the Club and one dollar to provide for the publication of a monthly magazine to be edited and managed by the Club, but the motion was voted down.

Business was followed by an enjoyable banquet in the Royal Hotel, where after a very sumptuous repast, the toast list was opened in the usual manner. Responding to the toast of "Our Employers", Mr. John McCullough, of the Shepard & Morse Lumber Company, made a very fitting speech. Mr. Archie McAdam spoke briefly and very happily to the of "Our Members". Mr. Harry Bennett toast favored the audience with two songs in his usual artistic manner. Mr. Frank Marshall, responding to the toast of "Our Guests", made the speech of the evening. In an exceptionally able manner, the toast of "Our Officers" was proposed by Mr. Ritchie and responded to by Messrs. Link and Reynolds. Mr. Ernest Pitt, the justly popular Secretary, was honored with a special toast. In responding, Mr. Pitt thanked the members for their sincerity and candor and for the generous

manner in which they had received the toast to his name. Mr. Frank Johnston gave two German songs in a style which was greatly appreciated. Mr. Wm. Murray also contributed to the program. Mr. Harry Bennett by special request sang "Ain't it funny what a difference just a few hours make" in a manner which brought down the house and the encores were loud and long. Mr. Dan Cashman, the genial proprietor of the Royal Hotel, responded in an able manner to the toast of "Our Host."

The Club have a system of registering by which the members when they arrive in the City must register their address and location of business. The following names were registered the evening of the convention:—S. R. Brock, Kazabazua; Wm. Burns, Ottawa; Ernest Pitt, Ottawa; G. H. Muir (CANADA LUMBERMAN), Toronto; A. Boucher, Ottawa; Fred Chilcott, Lescelles; Napoleon Millaire; James Green, Ottawa; Sam Meyers, Ottawa; H. H. Livingstone, Ottawa; W. J. Sparks, Aylwin, Que.; Jonahan Ardiel, Bryson; S. R. Kenney, Ottawa; H. W. Link, Ottawa; R. Woods, Antrim; W. A. Cameron, Ottawa; Roderick McCauston, River Desert; W. H. Farrell, River Desert; H. McConnell, Aylwin; D. McLennan, Ottawa; James Lafranie, Pembroke; J. Miller, Ottawa; W. J. McGrath, Whitney; A. G. Smith, Ottawa; James T. Leslie, Britannia Bay; W. Kydd, Ottawa; Michael Bang, Ottawa; Michael Field, Ottawa; J. Barnaby, Ottawa; Hamilton McCarthy, Ottawa; D. J. Driscoll, Ottawa; Wm. Swale, Ottawa; W. L. Donnelly, Ottawa; E. S. Taylor, Westmeath; Patrick Field, Ottawa; D. A. Martin, Ottawa; J. McCullough, Ottawa; Archie McAdam, Ottawa; W. H. Rice, Ottawa; H. J. Tripp, Fitzroy Harbor; John Piggott, Fitzroy Harbor; Alexander Brock, Hawkesbury; J. F. French, Kippewa; Bert Lambkin, Kippewa; J. Lorne MacLaren, Ottawa; R. St. Pierre, Ottawa.

The officers elected were: President, Jas. W. Bryson; agent, H. S. Brock; book-keeper, Archie McAdam; foreman, Napoleon Millaire; culler, John Miller; clerk, Herb Coughlin; secretary, Ernest Pitt. A distinct feature in the election of officers is that any member holding office in the club must occupy the same position in their respective business, either in the woods or office.

On the morning of the 20th the members had an excursion to Massina Springs, where a very enjoyable day was spent.

HINTS ON GLUE.

Ground glue may be soaked about 20 minutes, but that is not absolutely essential. As a general rule ground glue requires very little soaking.

Flake glue may be soaked in cold water over night, before using. All dirty spots must be avoided. They should be cleaned out every time before using a different kind of glue. For soaking glue fresh water must be used.

Glue should never be heated in a pot that is subject to the direct heat of fire; this invariably burns the glue and renders it useless.—Packets.

NEW HEADQUARTERS OF THE WESTERN RETAIL LUMBERMEN.

The Western Retail Lumbermen's Association are now located in fine new offices at Winnipeg. These offices are situated in the McIntyre Building, one of the best blocks on Main street and convenient to the hotels and depots. The officers of the association are as follows:—

J. L. Campbell, Melita, President; D. E. Sprague, Winnipeg, Vice-President; Isaac Cockburn, Winnipeg, Secretary-Treasurer. Directors: G. E. Davidson, Manitou; J. K. Robson, Treherne; J. E. Parrot, Saltcoats; G. B. Housser, Portage la Prairie; D. L. Lincoln, Winnipeg.

The Retail Lumbermen's Mutual Fire Insurance Company also have their headquarters in the same suite on the same floor of the Mc-

ber, besides two or three lumber commission agents.

PROGRESS IN THE LUMBER TRADE.

VANCOUVER, B. C., July 15th, 1905.

Editor CANADA LUMBERMAN:

In looking back over the last few years we see many marvellous changes in every line of travel, but in no line has the wonderful inventive genius of man been put to better use than in our own. So many and so swift have been the innovations that some have not been able to keep up with their introduction, and consequently are left far in the rear. Those who have kept up with the procession have done so under a tremendous strain, while a few have seemed to lead with comparative ease. It is to these few, however, that the credit is due for all the wonderful achievements in the manufacture, installation and manipulation of the different machines which go to make up the modern saw mill. With the up-to-date purchaser of wood-working machinery to-day the question of price is al-

ways the best there is to be had in machinery and thus the manufacturer of these machines and his highly skilled labor are benefitted. He secures the best men he can get to operate with and he and they are mutually benefitted, and at the same time he is promoting high ideals. He manufactures and sends into the markets of the world the best manufactured product, and here again he is benefitted, for he not only finds a ready market for his product at better prices than his would-be competitor who is trying to run his antiquated machines with poorly paid help is able to obtain, but he is building up a reputation—paving the road ahead of him as it were, and making it easier to travel in after years. This is all done by keen foresight—just such foresight as we find at the head of our leading wood-working industries of the present day, and if any one detail of this has not been pre-arranged then just so much of the road has not been paved, and right here is where disaster is going to be met in a greater or less degree according to the extent of the oversight. Thus it behoves us to see to it that the road is well paved ahead of us, and also that no part of this pavement is allowed to get worn out or in bad condition, but kept in constant repair. Never has competition in the wood-working industry been so keen as it is at the present time, and never have the demands of the consumer been more exacting; therefore, he who would excel as a manufacturer must see to it that everything he turns out is up to a high standard of excellence, and he cannot do this except he be equipped as aforesaid, not only with modern machinery but with an efficient staff of workmen who work not only with their hands, but also with their brain.

Anyone who has experienced it knows how good it makes him feel to get letters from across the continent from dealers stating that their customers won't have any other brand but such a one, when he is responsible for that particular production. Yes, it is gratifying to know that your efforts have been substantially appreciated.

This reminds me of a little incident which goes to show that all our efforts are not in vain, but may be bearing fruit when we are quite unconscious of the fact. When I was engaged in the lumber business in the State of Maine I found myself discussing the situation one day with one of those good old Yankees which it always does one good to meet. In the course of our conversation he remarked that he could always base his calculations on the predictions of the CANADA LUMBERMAN. He did not know how the editor of that paper obtained his information, but he had always found his reports and predictions authentic and thoroughly reliable. With such a standard-bearer as this going forth every week to be read by thousands of the very people whom we wish to reach, it seems to me that the manufacturer who has filled all the other requirements and has not secured advertising space to tell the public about it is leaving out a very important part of his pavement. To use a scriptural phrase, he is "hiding his light under a bushel."

In my next letter I shall endeavor to give the fraternity the benefit of some of my experiences and observations in the care and handling of wood-working machinery, and I think that an exchange of ideas by those engaged in the business would be to the mutual advantage of all, for how many of us are there who are at all progressive who have not at some time or other reached the hesitating point where we would like to have been able to have turned to some good authority to decide for us the important point in question. This authority can only be furnished by practical men, as theory without practice falls short.

Yours truly,

E. H. NEWTON.

ENQUIRY ABOUT SAWDUST.

LIVERPOOL, MAY 29TH, 1905.

Editor CANADA LUMBERMAN, Toronto:—

DEAR SIR,—I am very much interested to know what becomes of the sawdust produced in the Dominion of Canada.

The quantity must be very considerable and I should like to know if it is being utilized as a saleable article, and if so for what purpose.

I should also like to ask if it is manufactured in any way.

MOTHER COUNTRY.



MCINTYRE BUILDING, WINNIPEG—NEW HEADQUARTERS OF THE NORTH-WEST RETAIL LUMBERMEN'S ASSOCIATION.

Intyre Building. The officers of this company are:—

G. H. Hall, Winnipeg, President; J. A. Thompson, Winnipeg, Vice-President; Isaac Cockburn, Winnipeg, Secretary; R. W. Gibson, Winnipeg, Treasurer.

Directors: J. C. Graham, Winnipeg; D. L. Lincoln, Winnipeg; G. B. Housser, Portage la Prairie; A. N. Shaw, Miami; T. L. Arnett, Souris; A. D. Chisholm, Griswold.

The Association is to be congratulated on the progressive spirit manifested by these capable officers.

In the same building are also the following offices:—North Pacific Lumber Company, of Barnet, B.C., J. M. Hall, representative; Moose Mountain Lumber Company, of Arcola, Assa., J. A. Thompson, President; Business Brokers, manufacturers, agents for B.C. lum-

ways a secondary consideration, the adaptability of the machine for the particular work to be done being considered first. We are gratified to know that the number who have taken cognizance of this fact have greatly increased of late, and this should act as a stimulus to the manufacturer to go on with the good work, securing the very best ideas no matter what they may cost, because it is just those ideas that the leaders in the wood-working industry are after, and it is those leaders that the manufacturer of machinery is after.

Having built a thoroughly up-to-date mill and equipped it with the most modern machinery known for the class of work to be done, do we find this man looking for the cheapest men he can get to manipulate these machines? Well, I should rather say not! A poor machine in a good man's hands is better than a good machine in an incompetent man's hands, and therefore the man who is wide-awake enough to see that the best machines are installed is usually wide-awake enough to see that the best skilled men are secured to operate and take care of these machines, and with such a combination as this is it any wonder that this man is able to keep so far in advance? He

PRACTICAL FORESTRY FOR LUMBERMEN.*

By OVERTON W. PRICE,

Assistant Forester, United States Bureau of Forestry.

It is not the province nor the purpose of the Bureau of Forestry to attempt to teach the Southern lumberman the details of his business. I think that every man who has looked into it must realize that the United States owes its interior development, more than to anything else, to the enterprise, the industry, and the skill of those whose efforts have put the lumber industry upon the plane which it occupies to-day. If lumbering had not opened the way, the South would never have reached the commercial and industrial activity which she is now enjoying.

From the first attack upon the forest of your earliest forerunner, the colonist, your industry has increased steadily, until it is now fourth among the great industries of the United States. It has grown rapidly from small beginnings, fostered by the presence of an apparently inexhaustible supply of timber and by the impetus of an insistent demand. From "whip-sawing" to the modern steam saw mill is a long step, but it has not taken much over fifty years to accomplish it.

The present tendency of your industry is strongly towards economy. This is shown in your mills and in your methods for the transportation of lumber, but it is shown least of all in your dealings with the forest. This is the line of economy which it is the business of the forester to develop. The urgent need for such economy requires no statistics to prove it. You all know far better than I what is the situation confronting your industry to-day: that species and grades not long ago unknown in the market are now bought eagerly; that, in spite of the decrease in the cost of logging and of sawing, the price of lumber climbs steadily higher, and that there are already certain kinds of wood of high commercial value which are practically out of existence as a factor in the lumber supply.

Hitherto you have not had to consider the production of a second crop upon lands on which you have lumbered. So long as sufficient merchantable timber stood in sight to keep your mill running long enough to pay for it, and to yield in addition a generous return upon the capital invested in it, you naturally were not led to consider the future. That fact has been used by many enthusiasts as cause for criticism of lumbermen's methods as intemperate as it has been unjust. The question whether you shall cut with a view to immediate returns only or whether you shall cut also with a view to cutting over the same land again involves no emotional considerations, but is a question of business and of business only. I want to make it very clear that the forester—and by forester I refer not to the mere enthusiast, but to the man who deals with practical forest problems at first hand—is not an enemy to the lumberman. On the other hand, the highest effectiveness of the forester's work is impossible without the cooperation of the lumberman. The proof of the soundness of the forester's methods lies in the success of their practical application.

*Address delivered before the Southern Lumbermen's Association, New Orleans, La.

Unless the forester can prove to you that forestry pays, and cooperate with you in putting it into effect, then his efforts have been in large part fruitless.

There are a good many kinds of forestry. There is the forestry which must consider indirect return. There are cases in which the management advised for a forest must give weight to the value of that forest as a conservator of stream flow, and must not ignore its effect upon winds, upon climate, or upon the national economy. Such considerations must often govern in the forestry which is applied to public lands, since the long-time owner may consider such matters, and since the forest lands which are the property of the nation should be handled for the greatest public good, rather than for the highest immediate profit. For example, the best administration of the 60,000,000 acres of federal forest reserves must be based upon such a point of view. But these are not matters which you are called upon to consider in the management of your own lands, nor is there, in my judgment, a more serious mistake than to expect that private enterprise should or can be governed by considerations of indirect returns.

But there is another kind of forestry, the kind which I wish to present to you, which is purely a matter of business and which makes no other claim upon your approval or rejection. What we call practical forestry, which is merely another name for conservative lumbering, differs from the lumbering which you do only in its point of view. Practical forestry does not ask you to expend one cent unless there is reasonable promise that you will get a profitable return from its investment. It does not require you to consider indirect returns, such as I have just mentioned must influence the management of the forests of the public owner. It simply presents to you upon a business basis the results which you may expect from lumbering your lands, with a view, not to lumbering the same area once, but to lumbering it repeatedly. It simply enables you to take advantage of the fact that since trees have grown once they will, under proper treatment, grow again. Practical forestry does not mean that you will have to plant trees on your cut-over lands and wait until they have reached maturity in order to harvest them. That kind of forestry appeals only to the long-time owner, to the state or to the nation, or to the private land-owner in the treeless regions of the West, who, in order to have trees at all, must first plant them. But on practically every piece of land which you lumber there is left standing after the logging a certain number of immature trees—trees some of them slightly, some of them far below the diameter of the logged trees. If you log in such a way that these immature trees are broken by the fall of those which are cut, or if your cut-over lands are burned after the logging, the possibility of a second crop from them is so decreased as to be of no practical moment. But if, on the other hand, you lumber in such a way that these young trees, which form the basis of a future crop, are preserved both in the lumbering and afterwards, the second crop will in many cases become a

factor of no small financial importance in your undertakings.

Whether it will pay you to foster this second crop, both in your cuttings and afterwards, is the important question. For example, the Bureau of Forestry has found that in some cases the returns from practical forestry will yield an income of 6 and even a higher per cent. upon the capital invested. In other cases the interest is lower, and in others again it entirely disappears. In other words, forestry is not a panacea that can be applied to lumbering under all conditions and in every locality, but in the vast majority of cases it will pay, and pay well, to cut in such a way that you may cut again. Just how well it will pay, the Bureau of Forestry is ready to determine, and will be glad to determine, in co-operation with any one of you. It will give you, at a cost equal only to the actual living and travelling expenses of its agents engaged in the work, a detailed plan for the management of your tract, based upon a thorough study on the ground. This study will determine what is the present merchantable stand of timber upon your lands, what small trees remain as the basis for a second crop after the first crop of merchantable timber is cut, how fast these small trees will grow—and they will grow much faster after the old trees are removed—and what interest their growth will represent upon the capital invested in the land. It is not the intention of the Bureau to foist upon you any European system of forestry not adapted to your needs, but only to recommend, upon the basis of a thorough investigation, modifications of your present methods when such modifications will yield good returns. For example, let us suppose that you are cutting pine of merchantable size for lumber, and putting smaller pine into cross-ties. It would be the province of the Bureau to determine whether or not it would pay you best to allow all pine to reach lumber size and simply cut ties out of the tops, thus taking advantage of the more rapid growth of the smaller trees. In the same way you will often have to determine whether it is more profitable for you to tap small trees for turpentine or to let them grow until you can cut them for lumber. The forester can answer this question on a basis, not of surmise, but of a comparison of the value of these trees for turpentine and for lumber based upon actual measurement of how long it will take them to make lumber. Many of you are now using countless numbers of thrifty young pine for spur ties, for corduroy, for bridges, and for skids. The forester can tell you what these young trees are worth, because he can find out from actual measurements how long it will take them to make lumber and how much lumber they will make. And he will in many cases show you that you are throwing money away in using young pine trees for such purposes, and that you can save this waste by utilizing instead the tops of logged trees, culls, or trees of a kind less valuable than pine. In principle, practical forestry is an exceedingly simple matter; in application it requires trained men, both to solve its problems and to put their solution into effect.

Whether you will practice forestry or

whether you will lumber in the ordinary way is simply a question of whether you will treat your forest as a gold mine, ignoring its productive capacity, or whether you will lumber conservatively at a cost very little higher than under your present methods, and which will be repaid you many times over. Forestry can never offer you the spectacular opportunities for the investment of capital which the ordinary lumbering of a practically inexhaustible supply of timber has offered you and your predecessors. The trees do not grow fast enough for that. But they grow fast enough to make their preservation a good investment, and, with protection from fire, an eminently safe one. You are inclining more and more strongly towards greater capitalization of your mills and logging equipment and towards greater concentration in your logging operations. The era of the portable saw mill is practically over. There are few areas left in which a man can skim the cream of the timber and let the rest remain. You are cutting closer and closer year by year and you are attempting by improved machinery to offset the disadvantages of poorer timber and less accessible sources of supply.

Improved machinery is an excellent thing; economy in the mill is admirable also; but these alone will never solve the urgent problem before you. It is only by economy in the woods that you can, where there is reasonable safety from fire and where other conditions are favorable, make your plant, so to speak, self-supporting. If you omit economy in the woods, all economy elsewhere will only serve to postpone somewhat the time when your mill must shut down. It is perfectly natural that you should not turn with eagerness toward forestry, because you are just at the end of an era in which a plentiful supply of timber rendered it unnecessary for you to practice it. But now there is the question immediately before many of you whether you will lumber in such a way that you may keep your mill running continuously and draw a fair profit from your operations, or whether you will skim the land, shut down the mill and look elsewhere for an opportunity to carry out the same policy. The former method means in the vast majority of cases a safe and conservative business enterprise yielding fair and assured returns; under the latter method you may make more money for a little while, but you will inevitably in the end be forced either to practice forestry or to cease your operations.

I do not want to dwell here upon the effects of these two methods upon your industry as a whole. That is not the question before us to-day, although it is one which vitally concerns the interior development of this country. I merely wish to bring to your notice the fact that practical forestry has certain business advantages. You will not deny that you consider your mill as a part of your plant. Why not look upon your forest as a part of your plant also? The power to produce and yield you good returns is in the forest just as much as in the mill. It is simply a question whether it will pay you to develop that power, and that is a question which can in every case be determined. It is merely a comparison of capital

and of interest. The value of your cut-over lands represents the capital; the rate of growth of the trees upon them represents the interest. If in 10 years, or 20 years, or 30 years, or whatever the period may be, you could cut a second crop from logged-off lands, whose value, less the cost of the taxes and protection of the lands during the same period, represents a fair interest upon their capital value, then forestry is for you a good and safe investment. No man here would throw away anything which might have a money value until he had first determined whether that money value actually existed. I merely wish to present to you the advisability of applying the same policy to cut-over lands. Before you let your cut-over lands revert to the state for taxes, or before you lumber them in such a way that their productive capacity is destroyed, or before you let fire run through them, or before you sell them at a low figure as agricultural lands, first determine what they can yield you in a second crop; and in doing that the Bureau of Forestry is not only willing, but eager to give you its help in every possible way.

HISTORY OF THE LUMBER INDUSTRY OF NOVA SCOTIA.

BY F. C. WEITMAN,

President Western Nova Scotia Lumbermen's Association.

The whole of Nova Scotia with the exception of the cultivated valleys and the border of the sea coast is wood and timber land and will probably remain more valuable for timber than for any other purpose. No part of the country is over 60 miles from tide water, and navigable rivers flow into the Atlantic, Gulf of St. Lawrence and the Bay of Fundy. Three railway systems are in operation and the rails extend the whole length of the province. The shipping points of the railways are Sydney, Pictou, Pugwash, Windsor, Kingsport, Annapolis, Weymouth, Yarmouth, Tusket, Bridgewater and Halifax, from which lumber is exported; and besides these places there are very many ports and harbors on the coast available for good sized vessels and from which lumber is shipped. Proposed railways in Eastern Nova Scotia, and the Halifax and South Western on the Western coast, will still further open up the country. The harbors on the Atlantic coast have a good depth of water and very little tide. The shipping ports on the Bay of Fundy have strong tides, the rise and fall being from 25 to 40 feet. In many of these places vessels load lying aground, or in the stream where they can lie afloat, from barges and lighters.

At Ship Harbor, Halifax County, there is 30 feet of water at the mills, Liscombe 22 feet, Sheet Harbor 28 feet, and St. Mary's River 17 feet. Logs are on one side of the mill, and steamer or vessel berth on the other. There is no better harbor in Canada than Halifax, from which the annual export of lumber is over sixty million feet.

There are two grand divisions to be made in considering the lumber proposition of Nova Scotia, brought about by trade conditions. The Eastern end of the province ships almost entirely to the English deal market, the Western end to South America, West Indies and

the United States. The cut for the English market is 3 inch deals, and that of the West, boards, planks, rails and scantling. The deals are carried largely by liners or tramp steamers, while the Eastern Province engages a large fleet of sail vessels from 150 to 1,000 tons register, a favorable size for the West Indies being a vessel of 300 to 400 M. capacity, and for South America a vessel of 500 to 1,000 M. capacity.

Nova Scotia has the following specialties: It has the nearest spruce timber for shipment to the European market. It has a monopoly of the West Indian trade for cheap lumber. It has a natural reproduction of woods that cannot be excelled for rapidity of growth and quality. Its lumber fleet is largely owned in the province, the shipping facilities are excellent and inexpensive and the principal ports of shipment are open all the year round.

The reason that particular stress is laid upon the shipping condition is because the province depends entirely upon the export trade. The home consumption is so light it need not be taken into consideration. Thus, the small population of slow growth of the province compared with other countries has not had the effect of conserving the timber. On the contrary, the continued activity of the export trade of the past fifty years has reached the stage where the annual cut of the province has caught up with the yearly growth. The country was heavily timbered (say 100 years ago) with green timber of spruce, pine, hemlock, fir, poplar, Hackmatack and hardwoods, intermixed with white, yellow and red birch, maple, beech and oak.

The main growth to-day is spruce. The new growth is largely spruce, which will grow to cutting size in 30 or 40 years. White pine does not now exist in large bodies, but there are still good tracts of pine in Western Nova Scotia, and a second growth that rapidly comes to a cutting size in favorable localities. Spruce is the main stay, while the white pine is fast disappearing. Of other woods hemlock has not been largely manufactured and little use has been made of the bark. There are now large tracts of hemlock that command attention, and with the advancing prices of bark, it will be a valuable asset to the lumbermen. The hardwoods grow in the order already named, and up to the present time have not been cut for export, excepting for the English market in moderate quantity; but there has been and still is a large annual cut used for firewood both locally and for export to the United States, and hardwood is also extensively used for ship-building. In the Eastern end of the province there are extensive tracts of birch in Guysboro County, and in the western country hardwood is distributed all through the green wood, and much of it being old growth of good proportion. The extension of the railways will make these hardwoods more accessible and will probably lead to a large cutting within a very short time.

In the early history of the country the policy was to get it settled at any cost. Grants were made of large areas to private individuals and large numbers of soldier grants were issued to

take up wild land. Afterwards the local government came in possession of the ungranted land, and they for a nominal figure granted acres to all who applied; with the exception of about one and one-half million acres, now held by the Crown (most of this being a very poor description of wild land), the timber land is now owned by private individuals and corporations. It is estimated that about half the woodlands are in possession of large holders, and the other half of settlers and small holders of under a thousand acres. The larger holdings are being added to, and their position has been very much strengthened in the last two or three years. The owners also control valuable water privileges and shipping facilities. The lands are situated on rivers where there is an opportunity to drive logs to the mills, and in many cases to tide water where they are manufactured and shipped. There is excellent water power sufficient for lumbering and pulp mills all over the province. A logging railway is now under construction near Bridgewater, to be operated by the Davison Lumber Company. Many of the rivers furnish water power for electric light, so that manufacturing is no longer confined to the hours between daylight and dark.

The following subdivisions will give an idea of the extent of the lumber operations in Nova Scotia and of the export:

Total area of the Province, 21,000 sq. miles.

Estimated timber and woodland, 7,500,000 acres.

Estimated export from Western Nova Scotia, 110,000,000 sup. ft.

Estimated export from Eastern Nova Scotia, including Halifax shipments, 135,000,000 ft.

Total export, 245,000,000 ft.

Acreage, 7,500,000 ft.

The heavily timbered district would be about one-half of the above acreage, and is owned and controlled by lumber firms.

One of the chief dangers that threatens the lumber industry in Nova Scotia is forest fires, which have been an annual occurrence. There were laws covering this matter, but until recently there has been no enforcement of the Act. Within the past year the Lumbermen's Association of Western Nova Scotia, with the help of the Boards of Trade, have succeeded in having the law amended so that it could be enforced, and there has been a decided improvement during the past season. It is now believed that it will be possible to prevent any large forest fires in the future, and if this is done there is no doubt but that the growth of wood will increase the quantity of available timber within a very short time. The amended law provides for a chief fire ranger in each county, and he has the privilege of appointing under him other rangers to assist him in his duties. These rangers are to periodically go over their timber districts and extinguish all fires that may occur, and the chief ranger makes a report to the Government on each year's work. This special work is paid by Government salary to the head official and the municipality pays for the work done. The holders of timber lands in each county owning 1000 acres and over are taxed $\frac{1}{4}$ cent per acre.

This is a special tax levied for the purpose of controlling forest fires, and is paid in to the municipality. It is probable that in ordinary seasons this special tax will cover the cost of protection. Any balance left over goes to the credit of the fund. But in case this tax is not sufficient, the municipality is to pay any difference that may occur.

OTTAWA MID-SUMMER MEETING.

At the last annual meeting of the National Wholesale Lumber Dealers' Association held in Philadelphia, the invitation of the Canadian lumbermen, through Mr. Gordon C. Edwards, to hold a mid-summer meeting in Ottawa, was accepted. After further consultation and the assurance from a large number of members of their intention to attend, it was decided by the Board of Trustees to hold this meeting August 16th, 17th and 18th. The provisional arrangements are given below:

Dates include August 16th, 17th and 18th.

Business meeting August 16th—2 to 5 p. m.
Steamer on river in evening.

Business meeting August 17th—10 a. m. to 1 p. m.

Ottawa points of interest in afternoon or Rockliffe and a shanty lunch.

Banquet or other form of entertainment at night.

August 18th—Steamer trip to Lake Deschenes, log sluices, mills, etc.

The entertainments referred to will be furnished by the Ottawa valley lumber manufacturers.

The reports of the various committees will be made at this time covering the work of the Association since March and special consideration will be given to the matter of car equipment and freight allowance by the railroads as now before the Interstate Commerce Commission on the initiative of the Association.

The meeting promises to be very interesting and enjoyable and there should be a large attendance of representatives of the Canadian lumber trade.

THE CARE AND MANAGEMENT OF LEATHER BELTS.

By WALTER E. DIXON, M. E.

Outside of the direct care and management of high-pressure boilers and the steam lines pertaining thereto, there is no part of a power or lighting plant, mill or factory in which a large number of indirect connected machines are used that is of such vital importance as leather belting and rope drives. The subject under discussion in this paper will be the former, the selection, care and management thereof, while that of rope drives will be considered at some future time.

The first thing in order will be the selection of a leather belt, and when we consider that all makers make good belts, that there are no particular secrets in the belt-making business, and that in order to get the very best we must take every advantage of all small details in construction, it stands every engineer and belt user in hand to get all the information available, for we must remember that the percentage of good hides does not run very high, that all that are bought go into belt stock of some kind or other, and that someone must buy the goods that are not quite up to the standard of belt excellence. It is very evident that no man wants anything but the best when he is paying for the best, and it is also evident that no maker is going to say that he makes inferior goods; so therefore we must read the quality by what is in sight, and in the judging of leather that is already made up, the proposition resolves itself into a very hard one.

The two principal things left for an opinion to be based on as to quality are the relation the pieces that constitute the laps bear to the hide from which they were cut. They should, in belts running from 18 to 36 inches, be cut from the center of the hides, or should be what is known as "center stock." Of course all belts should be "center stock," but where they are very narrow or so wide that onehide will not be wide enough to make a lap, then there is always a lot of narrow stock worked in that cannot always be strictly center. The next thing to look out for is brands that are so deep that they destroy the life of the leather and will cause it to break after being used. Then look out for the length of lap. If this is too long, you will know that it runs into the neck, for about all that is possible to get out of average hides and still leave nothing in that is not first class is 54 or 56 inches. Ordinarily, you can tell if a lap is "center stock" by the marks that run down either side of the back bone; they will be usually a little darker than the rest of the belt. These marks or streaks should be in the center of the belt. The principal objection to neck leather is that it is liable to stretch excessively, and on this account it will put too much load on the piece immediately opposite it in a double-ply belt; for the point of one side is in the middle of the lap on the other side. Next look out for holes, which will usually be found so nicely plugged as to escape detection unless subjected to the most careful examination.

Next in importance is to buy a belt that has already been filled with some good waterproof dressing. Now I am quite ready to admit that to buy a belt that has been filled means to buy one that perhaps has some bad leather in it that would be seen in a dry oak tan belt, and also that the adhesive power of the filled belt is not quite equal to the dry one, but the points that the filled one possesses over the one not filled are, first and mainly, "it is filled with a preparation when you buy it that does not injure the leather in the least," and the preparation you will fill it with, for it will be filled, will be engine oil and water, a combination that will ruin any belt made, and also get it in a condition in six months that will make a permanent repair with glue impossible, for machine oil and moisture are strangers to glue and will ever be. More good belts are ruined by being soaked with engine oil until the points come loose and then pulled out of shape than from any other cause. Of course you may be able to keep a main engine belt that runs through a damp wheel pit and basement, and through a long damp tunnel to a main driven pulley that has two big boxes that are just as close to the pulley as a first-class machine designer could put them, and never get a drop of oil or water on it. If you can, I take off my hat to you; you are a wonder and in a class by yourself where you will ever be lonesome.

One very common cause of trouble with engine belts is the fact that such belts usually run under the floor where there is considerable moisture, and then the oil table under the average large Corliss engine will leak around dash-pots and rocker-arm shafts, and some oil will fly from the eccentric oil cups and get into the wheel and run around the rim and get to the belt, and if the belt is not filled a very few drops of oil will make a large spot on it. Then, if an engine does not run the whole twenty-four hours, while it is off, watch. A few drops of water from a leaky valve stem whose bonnet drain is stopped up, as they will sometimes be, has a way of getting through the floor and falling on to the belt and running down the inclined inside of it until it finally comes to the flywheel, which, with the assistance of its crowning face, very kindly makes a nice pocket for said water and proceeds to drink it up. Result: the glue is loosened and the belt may come apart in consequence. And should there chance to be a point just at the bottom of this pocket, it will get the glue soft enough to slip but may not open up, which is much worse than if it did open up, for it may slip away from the shoulder of the splice for half an inch, and when the engine is put to work it may close down by running under the wheel and stick, and, if it does, the result is that at no very distant day you will find a break at that particular place, right across the face of the belt. The reason is that the load was all taken off the inside half of the belt by point slipping, thereby making the inside of the belt too long and putting all the load on the out

side. The outside will continue to do all the work until it stretches enough to bring the inside back into service again. During this week or month you have been pulling your load with a single belt, not a double one, and after a short time you will find the break I referred to above in the shape of a clean, well-defined crack extending across the belt parallel with the points of the laps. Now of course you are going to send for the man who sold you the belt and ask him to fix it. If he is a wise man and understands his business, he won't do a thing but show you right under that crack a point that does not come up to where it should come. Then the thing for you to do is to say to him that the belt is examined every time it is put into service and that you have noticed that the points he refers to all come loose during a "run" and that anyone knows that a few

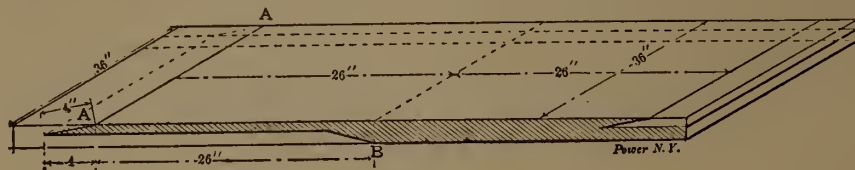

FIG. 1.

drops of water would not take any belt to pieces while it was running, and if it was water, why did it not take it apart everywhere, etc.? And finally crush him completely by telling him that your men have no time to put a pair of clamps on a belt in order to pull every point that comes loose back into its proper position, and that if they did do it they would have no time for anything else, especially in the present case, and that if his people had made the belt right the glue would have held, anyway.

After he has given you a new belt or repaired your old one, just take my advice and box that flywheel up above the top of the eccentric oil cup, at least 12 inches, and get some good, heavy tin or zinc and put a tight roof over the belt, under the floor.

First put in a ridge pole out of 1½-inch pipe, starting at the face of the wheel and running in the direction of the main driven pulley, holding it firmly in place at each end with a strong iron clamp. Then solder in each edge of the strip of tin, which should be long enough to reach beyond any possible leak through the floor or oil table, a piece of ½-inch pipe, and put tin over the ridge pole with a piece of small pipe on either side. Ordinarily the belt goes out past the cylinder, and if it runs through a bricked-up runway on its route to the main driven pulley, just fasten the two pieces of ½-inch pipe to either wall and have the ridge about 6 inches higher than the outside ones, and then every drop of oil or water that comes through the floor will fall on to the roof and run down to the walls and be carried down to the floor of the pit and have no chance to touch the belt.

One of the most difficult things in the operation of large stations where a large number of belts are used is to keep them thoroughly clean and free from moisture and machine oil, the latter especially. One very hard problem that confronts the designer of all machinery is the prevention of oil leakage from boxes. I have seen plants where as many as six dynamos of the same kind were in use and not one single departure from each other in the way of design, and in the

six there were at least four that I know of that leaked oil every time they were run. The others did not leak as a usual thing, and all were equipped with the most modern methods of holding oil.

Now we come to the building of the belt, and we will notice only such points as interest the engineer or buyer. The first thing is to see that the laps are of uniform thickness, so that the belt will run quietly, and it should be absolutely straight when unrolled on the floor. If it has a long, graceful curve in it, look out, for it will not run straight on the pulleys until it has stretched straight, and by that time one of its edges may be ruined by coming in contact with the floor or some other obstacle. Next notice how long the leather is from which it is made. It should not show more than 52 inches, and then there will be 4

inches hidden by the point that is out of sight. Then see that the joints are broken properly. For instance, find the center of any piece of leather on one side of the belt, and then look on the opposite side and see if the joint is right under your center mark. It should be by all means, for right here lies the most important thing about the construction of leather belts. A belt whose laps are all the same length, and which has all its joints broken correctly, will put the same load on the glue throughout, and that is what must be done in order to get best results. See Fig. 1. Here we have a belt that is 36 inches in width and a double ply. Now, suppose there is a draft of 9,360 pounds on this belt, and from point A to point B is 26 inches, and the

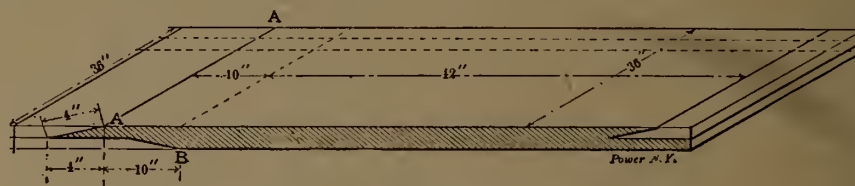

FIG. 2.

points are 4 inches long. Now we have 26 inches plus 4 inches plus 4 inches times 36 inches for the number of square inches in the glued joint. This equals 1,224 square inches, and the total pull on the belt divided by 1,224 will equal the load on each square inch of glued joint, and will equal in this case 7.65 pounds. Now if instead of distance A-B in Fig. 1 being 26 inches let the lower joint get out of step with the upper ones, and conditions get vastly different. We will suppose that the dimensions are as they are given in Fig. 2, which are taken from a new belt that I measured less than one month ago, and we have the following: Joint A B now is only 10 inches, and we have 10 inches plus 4 inches plus 4 inches times 36 inches = 648 square inches, and the load on the joint is now 14.44 pounds. You will readily perceive what an important part in the life of the belt, and the life of everything around the

belt as far as that goes, the proper breaking of the upper and lower joints is. Of course the belt maker will tell you that his glue is just as strong as the leather itself, and I will admit that he is about right as long as you keep the belt free from oil and water, but when the belt becomes filled with oil the glue rots and loses its strength much faster than does the leather.

No good belt needs any posts along the sides to make it run straight and stay on the pulleys. I have my first belt to see in the last fifteen years that would not run absolutely straight if the pulleys were in line and the belt straight.

All belts should be made to run perfectly straight on pulleys, first on account of the local advertisement that it gives to the man who has charge of them, and, second, if they do not run true and ever slip, they will be on the floor or wrapped around the shaft in a very few minutes. Another very important thing in the care of belts that carry heavy loads is that if any of the points do come loose so far back they will not return to place without putting on the clamps; put them on by all means, as the restoring of this point to place means that you will still retain in service all of your belt, as you will not do if you glue it down where it is and thereby cut one side completely out of service.—Power.

THE SALE OF TIMBER LIMITS.

At the second annual convention of the Associated Boards of Trade of the Northwest Territories held at Regina on the 30th of June, the following resolution was discussed:—

"That it is considered highly undesirable that any timber limits in Western Canada should be sold, except under conditions requiring reasonable use to be made

of such berths within not more than two years of the date of sale; and in the event of the purchaser failing to make use of such timber berth within two years from the date of the purchase, such berth should revert to the Government to be available for sale to any parties desirous of utilizing the timber thereon. And that the Minister of the Interior be respectfully asked to give this matter his most careful attention."

The Edmonton Board of Trade are supporting this resolution strongly.

—The North Star Lumber Company, of Cranbrook, B. C., have recently placed an order with the Vancouver Engineering Works for a complete new drive and also for the live rolls for their mill. This contract was taken in competition with a number of local firms.

"STERLING" OILS

FOR SAW MILLS

WE SOLICIT ORDERS
TRADE LARGE AND SATISFACTORY
OUR AGENTS WILL CALL WITH "STERLING" CYLINDER,
ENGINE, DYNAMO, MACHINE AND SPECIALTY OILS

Greases, Packing, Waste, "Copperine," Ready Mixed Paints, Varnish, Red and Black Roof Paint; Smoke Stack Black for Boiler Fronts and Sawmill Refuse Burners, White Lead, Dry Colors, Etc.

Canadian Oil Co., Limited
Strachan Avenue, TORONTO, ONT.

Please mention THE CANADA LUMBERMAN when corresponding with advertisers.

Galt Machine Knife Works

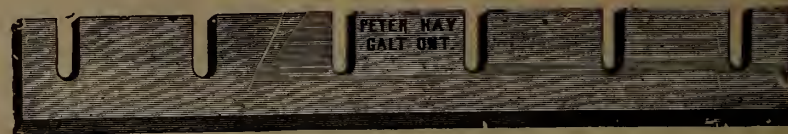

MACHINE KNIVES OF EVERY DESCRIPTION
FOR Woodworking Machines
... Send for Price List ...
The Peter Hay Knife Co., Limited Galt, Ont.

CANADA LUMBERMAN

AND WOOD-WORKER

WEEKLY EDITION

The Lumberman Monthly Edition 44 pages } \$1.00 PER YEAR { The Lumberman Weekly Edition every week.

THIS PAPER REACHES REGULARLY THE PRINCIPAL LUMBER MANUFACTURERS AND DEALERS THROUGHOUT CANADA, AND WHOLESALE BUYERS IN GREAT BRITAIN, THE UNITED STATES, AND OTHER FOREIGN MARKETS.

VOL. XIII

TORONTO, MONTREAL — AUGUST 2, 1905 — WINNIPEG, VANCOUVER

No. 22

CANADA LUMBERMAN

PUBLISHED BY

The G. H. Mortimer Publishing Co'y
of Toronto, Limited

Confederation Life Building - TORONTO.

Branch Offices:

38 ALLIANCE BUILDING, MONTREAL
720-721 UNION BANK BUILDING, WINNIPEG.
Telephone 1274
536 HASTINGS ST., SUITE 3, VANCOUVER, B. C.
22 GREAT ST. HELEN'S, LONDON, E. C.

The Weekly Lumberman — Published every Wednesday, contains reliable and up-to-date reports of market conditions and tendencies in the principal manufacturing districts and leading domestic and foreign wholesale markets. A weekly medium of information and communication between Canadian timber and lumber manufacturers and exporters and the purchasers of timber products at home and abroad.

The Monthly Lumberman — A 44-page journal, discussing fully and impartially subjects pertinent to the lumber and wood-working industries.

WANTED AND FOR SALE

Advertisements will be inserted in this department at the rate of 15 cents per line each insertion. When four or more consecutive insertions are ordered a discount of 25 per cent. will be allowed. This notice shows the width of the line and is set in Nonpareil type; 12 lines make one inch. Advertisements must be received not later than 4 o'clock p. m. on Tuesday to insure insertion in the current week's issue.

WANTED—1", 1 1/4", 2" COMMON BEFCH, Birch and Hard Maple 5/4 Beech C & B. 1", 6/4" 2" Wormy Chestnut. All dry. R. E. KINSMAN, Hamilton, Ont.

SPRUCE AND TAMARAC DIMENSION for sale, either quality furnished—sizes 6x6 up to 10x12, some 12x12, 18 to 24 ft. lengths, percentage longer if required. Address Box 302, care of CANADA LUMBERMAN.

HEM-LOCK DRY HEMLOCK WANTED—ALSO Cedar Shingles and Lath TORONTO LUMBER COMPANY, 432 Ontario Avenue, Toronto.

WANTED — PARTNER WITH SMALL capital for good paying, contracting and lumber business in good live western city in Ontario. Address Box No. 246, CANADA LUMBERMAN.

FOR SALE—THREE LANCASTIRE BOILERS 250 H. P. each. Good for working pressure of one hundred lbs. each. Apply to ALFRED HAWKESWORTH SONS & Co., LTD., 551 St. James Street, Montreal.

HAVE YOU ANY STOCK WHICH YOU wish to sell? If so, make the fact known to probable buyers by placing an advertisement in the Wanted and For Sale Department of this journal. Address, CANADA LUMBERMAN, Toronto.

FOR SALE

OVER FOUR MILLION FEET OF STANDING timber and land composed of chestnut, whitewood, oak, ash, maple, basswood, elm, beech, with 10 M capacity mill; 2 railways running through property; good market for cordwood, tile wood, stove wood, hubs, spokes and everything in the product of a sawmill—including planing and matching machine, shingle machine, and moulding machine; containing 350 acres; will be sold either in whole or part. Railway spur on property; the best lot of timber in these parts. Original forest. J. C. SCHLEHAUF, Owner, Bismarck Station, West Lorne P. O., Ont.

WANTED—ALL PULP MILLS AND PULP WOOD Companies to look up page 7 monthly issue, which is bound to interest you.

WANTED — TEN THOUSAND CORDS Hard and Soft Wood; also same quantity of Slabs. SIMCOE WOOD AND LUMBER CO., 52 Yonge Street Arcade, Toronto.

CEDAR FOR SALE — 10,000 PCS. ROUND Cedar 8-16 and 25 feet long, at the Spanish boom. Also cedar, pine and spruce lumber for sale here at Larchwood. JAMES MCCREARY, Larchwood, Ont.

FOR SALE

1" and 1 1/4" 1904 winter cut, mill run, trimmed Hard Maple.
1" 1904 winter cut, mill run, rough edged, Hard Maple.
1" 1905 winter cut, trimmed, all pure White Hard Maple.
1", 1 1/4" and 2" 1905 winter cut, mill run, trimmed Hard Maple.
Write for lists and prices. The W. R. THOMPSON Co., Teeswater, Ont.

FOR SALE

White Pine Lumber

NO. 1 SHEET.

Feet
1,895 3/4" x 4" up x 6/11 ft. M/C shorts
2,962 1" x 10" x 12/16 ft. M/C stocks
27,735 5/4" x 4" up x 6/11 ft. S/C shorts
NO. 3 SHEET.
26,945 1" x 4" up x 6/11 ft. sound common
44,193 5/4" x 4" up x 6/11 ft. sound common
994 1" x 8" x 12/18 ft. sound common
852 6/4" x 4" up x 6/11 ft. sound common
69 1" x 11" x 12/18 ft. sound common
10,567 1" x 4" up x 6/11 ft. second quality
8,234 5/4" x 4" up x 6/11 ft. second quality
69,000 5/4" x 4" up x 6/11 ft. second quality
2,621 5/4" x 8" up x 12/18 ft. second quality
44,400 2" x 4" up x 12/18 ft. second quality
38,457 2" x 6" x 12/18 ft. second quality
NO. 4 SHEET.
118,214 4/4" x 6/11 ft. S/C shorts
74,606 5/4" x 6/11 ft. S/C shorts
2,521 6/4" x 6/11 ft. S/C shorts
66,271 1" x 8" x 12/16 ft. S/C and better.
2,882 5/4" x 12/16 ft. M/C sidings
39,826 5/4" x 12/16 ft. M/C strips
37,861 5/4" x 4" up x 6/11 ft. M/C shorts
7,435 6/4" x 4" up x 6/11" M/C shorts
3,222 5/4" x 8" up x 6/11 ft. M/C shorts
NO. 5 SHEET.
66,539 8/4" x 12/16 ft. M/C sidings
5,762 5/4" x 4" up x 6/11 ft. M/C shorts
33,627 8/4" x 4" up x 6/11 ft. M/C shorts
10,746 4/4" x 8" up x 6/11 ft. M/C shorts
46,630 4/4" x 6/11 ft. S/C shorts
14,574 4/4" x 6/11 ft. S/C shorts
1,218 6/4" x 6/11 ft. S/C shorts
4,680 8/4" x 6/11 ft. S/C shorts
4,317 6/4" x 12/16 ft. S/C strips

NO. 6 SHEET.

1,456 1" x 4 1/2" x 6/11 ft. M/C shorts
7,194 1 1/2" x 4 1/2" x 6/11 ft. M/C shorts
1,164 1 1/2" x 4 1/2" up x 6/11 ft. M/C shorts
13,804 1" x 8" up x 6/11 ft. M/C sidings
4,310 1 1/2" x 4 1/2" x 12/16 ft. M/C strips
9,373 1" x 8" up x 12/16 ft. M/C sidings
161,856 1" x 4" up x 6/11 ft. S/C shorts
21,719 1 1/2" x 4" up x 6/11 ft. S/C shorts
2,438 1 1/2" x 4" up x 6/11 ft. S/C shorts
370,168 1" x 4 1/2" x 12/16" S/C Strips.
25,703 1 1/2" x 9" x 12/16 ft. M/C stocks
11,795 1" x 9" x 12/16 ft. M/C stocks

NO. 7 SHEET.

200,000 1" x 4 1/2" x 12/16 ft. second strips

NO. 8 SHEET.

147,913 1 1/2" x 12/16 ft. S/C sidings
297,073 1" x 12/16 ft. S/C sidings
217,932 1" x 10" x 12/16 ft. good
54,295 1" x 11" up x 12/16 ft. good
33,948 1" x 12/16 ft. second strips.

A. F. BURY AUSTIN,
Wholesale Lumber & Timber Merchant,
Montreal.

A FEW CARS OF GOOD BASSWOOD LUMBER for sale; also basswood heading. I. C. SCRIPTURE, Coe Hill, Ont.

WANTED—FIRST CLASS PLANING MILL and bench man, must be able to do lathe work. Work the year round for right man. Apply to Box 303, CANADA LUMBERMAN, Toronto.

FOR SALE.

FIVE CARS OF 2" AND TWO CARS OF 1" soft elm, common and better; also two cars 1" and 1 1/2" basswood. All 1904 cut. Box 245, CANADA LUMBERMAN.

WANTED

A SAWYER—ONE WHO CAN CUT ALL kinds of lumber for small Circular Saw-Mill cutting from 10 to 15 thousand ft. per day. Will have about three months cutting. Write at once, stating salary, to CURRY & THRASHER, Deux Rivieres, Ont.

FOR SALE AT ONCE

COMPLETE PLANING MILL OUTFIT, including Boiler 56" x 12" and Climax Engine 9 1/2"x12", all new. MANITOU LUMBER Co., North Bay, Ont.

—Important to—

LUMBERMEN & SAWMILL MEN

Auction Sale of Valuable

Timber Berths, Sawmill,
Logs and Lumber
Business

ON THE GEORGIAN BAY

The executor and trustee of the estates of the late George M. Tanner and Wm. H. Tanner, of Sturgeon Bay, Waubaushene, and known as Tanner Bros., Lumbermen, have given instructions to the undersigned to sell by public auction at the rotunda of the Board of Trade, Toronto, ON THURSDAY, AUGUST 31ST, 1905, at 3 o'clock p. m., on the terms and conditions which will be announced at the time of sale, the timber berths logs, mill, plant, camp outfit, buildings, horses, etc., etc., in one lot for a lump sum. The property of the estates of the late firm of Tanner Bros., as undermentioned, namely:—

Timber berth No. 119, north shore of Lake Huron, well timbered with pine, pulpwood, etc. *Two-thirds interest in timber berth, Township of McKinnon, well timbered with pine, hemlock, spruce, etc. *The other third of this township can be purchased privately on reasonable terms.

Timber berth No. 61—(This berth has been nearly cut out.)

Logs—Six and a half million feet, B.M., of excellent pine logs to be delivered at the mill by the vendors.

Sawmill at Sturgeon Bay—Capacity, about 60 M. feet per day, with latest equipment, complete for lumber and latb. (Nearly new.) Engines, boilers, buildings, boarding house, two good residences for owners, workmen's houses, barns, horses, workshops, plant, tools, booms, chains, camp outfit, and 50 acres of freehold land.

Booming ground, extensive and safe in all weathers.

Piling ground, ample for nine million feet of lumber, with excellent shipping facilities of water or G. T. R. siding at mill.

Terms of sale: The whole of the above properties will be offered as one lot or parcel, and subject to one bid by the vendors. Payments—Cash for the logs at \$18 per 1,000 feet, B.M., plus cost of sawing up to the time of transfer, and credit allowed for all product cut. Cash for camp outfit and supplies, and for the balance, one-third in cash at the time of sale, one-third in one year, and one-third in two years, with interest at 5 per cent. Ordinary cutting conditions. For maps and further particulars apply to the estate of Tanner Bros., Waubaushene, Ontario, or to PETER RYAN, Toronto.

WANTED—POSITION

A STENOGRAPHER AND OFFICE WORKER. Several years experience in wholesale lumber office. Address Box 305, care of CANADA LUMBERMAN.

FOR SALE — 550 ACRES OF STANDING timber in North Hastings, comprising soft elm, ash, basswood, hard maple, cedar, hemlock, etc. Estimated to cut about two million feet, board measure. Will sell cheap for cash. Easy to log and a railway close by. Apply Box 111, CANADA LUMBERMAN.

WANTED TO PURCHASE

HEMLOCK OR SPRUCE 10 x 10 x 12 FT. and 30 ft., British Columbia fir 10 x 10 x 12 ft. and 30 ft. Several carloads of each dimension. Address, giving full particulars regarding quality and price, Box 304, CANADA LUMBERMAN, Toronto.

FOR SALE

100 M 4/4 birch
20 M 10/4 and 12/4 birch } Com. and better.
10 M 4/4 black ash
15 M 4/4 elm
25 M 4/4 pine
8 M 6/4 " } Mill run.
40 M 4/4 basswood
THE MAGANETAWAN HARDWOOD LUMBER Co., Alimic Harbour, Ont.

CURRENT TRADE CONDITIONS.

ONTARIO.

It might be expected that at this season of the year the reports concerning the lumber market would indicate a quiet trade, and to some extent this is the case, but it is also very noticeable that the conditions, apart from immediate demand, are considered very satisfactory. The large domestic consumption of pine and hemlock is keeping up remarkably well, assisted, of course, by the extensive building operations. "Business has never been better," was the reply of a manufacturer to a question as to lumber conditions. Considering the smaller production of lumber on the Georgian Bay this season, stocks at the close of the sawing season are not likely to be very large. The Ottawa valley mills will have plenty of logs for a full season, but no great accumulation of lumber is looked for, and at the present time there is no indication of prices weakening to any extent.

There is quite a strong market for lath, which are looked upon as good property. Prices have broken very little since the spring, and the prevailing price for No. 1 pine at the mill is about \$3.

QUEBEC AND NEW BRUNSWICK.

In Montreal the demand for lumber continues to be curtailed by the strike of carpenters. It was expected that this would be terminated last week, but the master builders have refused to accept the offer of another conference with the men. Nevertheless, considerable building is in progress and there is quite an active movement of lumber. There is not much activity in lumber circles in the Maritime Provinces and it is now quite certain that

the volume of business with Great Britain will be much below the average. Nova Scotia manufacturers are doing a good trade with South America and the West Indies and prices are firm. The quantity of lumber at the mills is fully 30 per cent. less than at the same time in 1904. Sales of deals are being made at \$13 for a specification of 60 per cent. 7's and 8's and 40 per cent. 9's and 11's. There has been no recovery in the New Brunswick cedar shingle market and the majority of sales are now being made around \$3.30 for Extras on Boston rate of freight.

UNITED STATES.

The lumber demand is perhaps more uneven than at any previous times this year. The situation in respect to southern pine and white pine continues strong and the demand is practically equal to the supply. At Ashland, Wis., 85 per cent. of the season's cut of white pine has been sold and it is estimated that at the end of the season no surplus stock of any account will be left at the producing points. Certain sizes of low grades are reported to be almost out of the market at Buffalo and Tonawanda. Hardwoods represent the opposite condition, the demand being quiet and the supply of stock more plentiful notwithstanding that many of the mills have, owing to wet weather, been producing much less than the usual quantity. Plain oak is receiving the greatest call. Basswood and maple are weak, while birch is strong. Log run maple has been selling in the Saginaw Valley at a considerable reduction from the high point reached earlier in the year.

There is quite an active market for spruce and most of the mills have plenty of orders. It is not improbable that prices will be marked up a little in the near future. The hemlock market also gives indications of strength. Short lengths are quoted in the Saginaw Valley at \$13, 16 foot at \$14, and 18 foot at \$15.50. Boards are worth \$14.

Lath are showing increased strength. The price list committee of the Mississippi Valley Lumbermen's Association have decided on an advance of 25 cents a thousand in all grades. This was agreed to by correspondence after the meeting on July 13,

it being shown that stocks on hand are extremely light. The tone of the shingle market is also more hopeful and it is believed that any change in prices will be in the direction of an advance. The action of the red cedar mills in curtailing production has had a beneficial effect.

GREAT BRITAIN.

The deadlock between shippers and importers still exists. The former are holding to their prices, while the latter are endeavoring to bring about a general reduction of about five shillings per standard, at which price it is believed many importers are prepared to operate. If they should not be successful in further breaking the market within the next week or two, it is probable they will come to the conclusion that prices have about reached bottom and will then place contracts for stock for autumn delivery. As the quantity of lumber contracted for is very small, any indication of an advance in prices might cause considerable anxiety among merchants who have allowed their stocks to become almost exhausted in the hope of buying to better advantage later in the season. Deal sizes are still in very little demand except in the better qualities. There has been no particular change in the pine situation, the high prices asked being against business. The reports concerning spruce are by no means uniform, but it is thought that a good foundation is being laid for an advance in the fall. It is reported that one or two small cargoes have changed hands at £7 5s c.i.f. Liverpool, with a specification of about 60 per cent. of narrows and short average. The lowest sale of the season was a large cargo at £7 c.i.f.

STOCKS AND PRICES.

It is reported that 300,000 logs are hung up in the Spanish river.

Louis H. St. Laurent, of Sutton, Que., is making heavy shipments of hardwood timber to Glasgow, Scotland.

The cut of deals by the Bay Shore Lumber Company, Salmon River, N. B., this season will be about 3,000,000 feet.

Rafting operations on the South-west Mirimacbi river, in New Brunswick, have

been finished. The quantity of logs is not more than half of last season's total, which was 60,000,000 feet.

Mershon, Schuette, Parker & Company, of Saginaw, Mich., have acquired about 15,000,000 feet of lumber in the Georgian Bay district which will be shipped to their Saginaw and Bay City yards.

A statement compiled by the Wisconsin Valley Lumbermen's Association shows that shipments for six months of this year aggregated 224,847,000 feet, as against 231,663,000 feet during the first six months of 1904.

The Department of Indian Affairs, Ottawa, will receive tenders up to Friday, September 1st, for the spruce timber of 9 inches and over in diameter at the stump on the Patcheena Indian Reserve in British Columbia. Information may be obtained upon application to the Indian Superintendent at Victoria, B.C.

E. B. Lloyd, Crown Timber Agent at New Liskeard, Ont., reports that the cut of logs in that district last winter was smaller than the previous year and that great difficulty was experienced in getting them out owing to low water. In addition to the saw logs taken out, 396,601 ties were manufactured, valued at \$64,611.30.

The Upper Ottawa Improvement Company will bring 3,000,000 logs down the river this summer, which is a larger number than has been brought down for some years. The reason for this is that the quantity will include 400,000 logs which were cut in the winter of 1903-4 and have since been held in the booms at Des Joachims.

The following cargoes of lumber recently reached the Saginaw river: 477,092 feet from Thessalon, Ont., consigned to E. B. Foss & Company; 196,644 feet from Cutler, Ont., consigned to F. G. Eddy & Company; 502,175 feet from Little Cur-

W. C. CRAWFORD

Tilbury Ont.

Manufacturer of . . .

Handles—Axe, Fork, Pick, Etc.

Also Hard and Soft Wood Heading, and Red and White Oak, Maple and Elm Lumber.

Can supply Second Growth White or Red Oak squares up to 38 in. long in large quantities.

EMPLOYMENT BUREAU

R. B. ST. GEORGE

RAILWAY, LUMBER and CONTRACTORS' AGENT

158 Canal St. Russell Block, Ottawa. Men wanted at all times for Bush and Railroad Work. Phone 1,950

ARTHUR A. WATT

WIARTON, ONT.

Dealer in Hard and Soft Wood, Lumber, Lath, Shingles, Cedar Posts and Ties

SPECIAL—50,000 4/4, 8/4 and 12/4 Soft Elm 30,000 8/4 Maple, C & B.; 18,000 4/4 Soft Maple 100,000 4/4 M. R. Basswood; 18,000 4/4 Mill Run Pine Sittings, 40,000 4/4 and 8/4 Birch; 40,000 6/4 Beech. Prices on application.

A SPLENDID ROUTE.

The Wisconsin Central Railway is justly termed the "Sportman's Line" because it reaches into and through the very heart of the choicest hunting grounds in America.

The very best wild fowl shooting of the entire North is reached ONLY by this line. Hundreds of beautiful lakes abounding in wild rice and celery attracts myriads of ducks and geese and afford the finest kind of cover and the choicest shooting to be found the country over.

The Wisconsin Central Railway caters especially to the sporting public and during the various seasons for hunting and fishing furnishes daily information to its patrons as to local conditions anywhere along its lines upon application to the nearest ticket agent. It also arranges its train service with special reference to the convenience and comfort of sportsmen, and its employes are constantly on the alert to make travel over their lines pleasant and comfortable.

This line offers the best route between Chicago, St. Paul, Milwaukee, Minneapolis or to Lake Superior points via Ashland, Wisconsin.

Information given by addressing—

JAS. C. POND, Wis. Cent. R. R. Milwaukee.

HELP!

Can be obtained at small cost by advertising in the Want Columns of THE WEEKLY CANADA LUMBERMAN.

WOODS & SPICER, Limited

.....MANUFACTURERS OF.....

BRITISH COLUMBIA RED CEDAR SHINGLES

Capacity 100 Million a Year.

We have had over 15 Years Experience, and are not Asking our Competitors for any Pointers as to Quality.

Wire Your Orders at OUR EXPENSE to Agents, or to us at VANCOUVER, B. C

KNIGHT BROTHERS CO. LIMITED, Burk's Falls, Ont. KILN-DRIED BIRCH FLOORING Send for Catalogue & Samples by Mail KNIGHT BROTHERS CO. LIMITED, Burk's Falls.

Keenan Bros., Limited

Owen Sound, Ont.

HARDWOOD, HEMLOCK AND PINE LUMBER

We carry a full supply of native Hardwoods always on hand and solicit your inquiries. At the present time we have piled at outside points about 2,000,000 feet of Hardwoods, and about the same quantity of Hardwood, Hemlock and Pine piled here in Owen Sound, and we should be able to interest you if in the market.

WILL MAKE SPECIAL PRICES ON BROKEN LOTS AT OUTSIDE POINTS

Planing and Matching

—IN TRANSIT—

S. POMEROY, Orillia

PLANING, MATCHING, RESAWING, SIDING, FLOORING, MOULDINGS in Car Lots.

Factory near Station. Write for Prices. Phone 113

MASON, GORDON & CO.

WHOLESALE TIMBER

Montreal, Quebec

Eastern Agents The B. C. Mills, Timber & Trading Co., Vancouver, B. C.

DOUGLAS FIR Timber in any size or length supplied WRITE FOR PARTICULARS AND QUOTATIONS.

EVERYTHING IN LUMBER AND TIMBER DRESSED AND IN THE ROUGH

M^CLENNAN LUMBER CO., LIMITED

MONTREAL QUE.

Office and Yard, 571 DORCHESTER ST.

P.O. Box 116

rent, Ont., consigned to Bradley, Miller & Company; 545,331 feet from Cutler, consigned to Foss & Company; 517,085 feet from Tbesalon, consigned to Foss & Company.

Following is a comparative statement of timber, etc., measured and culled at Quebec up to August 1st, as reported by the Supervisor of Cullers:—

	1903	1904	1905
Waney White Pine.....	1,083,440	1,484,280	1,039,560
White Pine.....	188,920	145,160	133,520
Red Pine.....	34,000	2,960	1,200
Oak.....	494,040	187,840	22,160
Elm.....	364,080	200,680	477,840
Ash.....	50,760	14,160	8,760
Butternut.....		40	120
Birch and Maple.....	189,560	114,680	197,600

BRITISH COLUMBIA LETTER.

(Correspondence of the CANADA LUMBERMAN.)

VANCOUVER, B.C., July 25.—After a summer of fairly good business, the trade in connection with the lumber industry is beginning to subside. It may be that because of harvesting operations, the farmers in the Northwest are not requiring material for building, but just at present there is quite a lull. Some of the mills are taking advantage of it and are shut down for overhauling, something which seldom occurs as early in the season as this. This applies particularly to the mills on the coast. Some are still going full time of ten hours, while others are adding to stock.

Up-country, conditions seem to be somewhat better. The mills of the Kamloops Lumber Company are going even overtime, and the Mundy Lumber Company, which will start operating this week or next, proposes to run night and day. And yet in parts of the Kootenay the fear

of the sheriff has not altogether been dispelled. On the whole, conditions are not nearly as bad as last year at this time, with the exception, perhaps, of the shingle branch of the industry. Prices, too, have been maintained, while during the late summer and fall of 1904 cutting of prices was going on. What has been sold has brought a fair figure.

There is no appreciable betterment in the logging industry. As stated two weeks ago, the extensive operations of large numbers of camps are resulting in over-production. With the brisk business of the spring still continuing there would be none too much demand for logs, but with the falling off in trade many booms will go hunting for buyers.

There is not a great deal of talk on the coast concerning the pool of the Mountain lumber manufacturers which was effected at Calgary a short time ago. That did not come as a surprise to those who have been watching conditions in the rapidly developing Territories, and before a very great length of time has elapsed the western manufacturers will have their own yards in the consuming districts. This will be hastened by the advent into British Columbia of American lumbermen, who have successfully carried on business by such methods for a number of years.

The talk emanating from American sources of the probability of the United States Government withdrawing the duty on lumber entering that country is regarded by prominent lumbermen here as merely a blind. If the duty is withdrawn, it will be with the idea of stopping if possible the imposition of a similar duty by

Canada, and a repetition of the tactics of 1896 are looked for. Even with the duty off, the American lumbermen would still have the best of the bargain, as all the raw material used by Canadian manufacturers is very heavily taxed, and the cost of production is, accordingly, much higher in comparison.

LOG QUOTATIONS ADVANCE.

The Lumber Review states that fir logs have advanced from fifty cents to one dollar per thousand. One year ago at this time there was a surplus of 155,000,000 ft. in the waters of western Washington, but at this time there is not 20,000,000 above the regular demand. Logs have never been known to be so scarce on Puget Sound at this time of the year. There are but very few small loggers operating and the larger concerns represented in the Washington Logging and Brokerage Company are working with a decreased force. The advance in fir logs became operative on July 1. No. two went from \$4.50 to \$5, merchantable from \$6.50 to \$7, flooring from \$8 to \$8.50, and long dimension material jumped up \$1.

NEW BRUNS LUMBER SHIPMENTS.

The shipment of deals from St. John, N. B., this year has exceeded that of last year to the same date by about 17,000,000 feet. Shipments to June 30 and for the corresponding period last year were:

	1905	1904
Spruce deals, etc. sup. ft.	82,000,000	65,000,000
Birch planks, sup. ft.	4,500,000	2,700,000
Birch timber, tons	3,200	2,000

Deal shipments from points at the head of the Bay of Fundy have been 25 per cent. less than last year and from

Halifax 40 per cent. less. It is estimated that the total Nova Scotia spruce shipments this year will not be more than 60 per cent. of those of last year.

L. Dean Holden, Pres. J. M. Diver, Gen'l.-Mgr.
A. F. Holden, Vice-Pres. E. C. Barre, Ass't Mgr.

The Cleveland-Sarnia Saw Mills Co., Limited.

Manufacturers and Wholesale Dealers in

Timber, Lumber, Lath and White Pine Shingles

Special Bills Cut to Order in White Pine, Norway and Fir, any length from 10' to 60' long.

—SARNIA, ONT.

M. & L. Samuel, Benjamin & Co.

503 Temple Building, Toronto.

EXPORT DEPARTMENT.

Correspondence solicited with exporters of wooden goods, such as Sanitary Woodenware, Broom Handles, Fork and Shovel Handles, Turned Goods, etc. Payments made on receipt of Bill of Lading at Toronto. European House, SAMUEL SONS & BENJAMIN, 16 Philpot Lane, London, Eng.

J. B. Farwell & Son

CONTRACTORS AND DEALERS IN . .

Canadian Cedar Telegraph, Telephone and Electric Light Poles

Bancroft, Ont., and Oswego, N.Y.

FOR SALE

Exceptionally good Birch and Hemlock Lumber f.o.b. car South River Station. Mills at Midford (Eagle Lake,) Ont.

THE ROBB LUMBER CO., LIMITED
Guelph, Ont.

Hunter, Crawford & Niebergall
(Successors to R. Watt)

LUMBER AND SQUARE TIMBER OF ALL KINDS
POSTS, POLES, TIES, LATH AND SHINGLES

Bill Stuff a Specialty WIARTON, ONT.
Write Us for Hard and Soft Wood Slabs.

THE IMPERIAL LUMBER CO., LIMITED

SAW AND PLANING MILLS, WARREN, ONT.

RED AND WHITE PINE DEALS

All kinds of
SAWN LUMBER
By Carload or Cargo.

BRANCH OFFICE, MANCHESTER, N.S.
Head Office, TORONTO, CAN.

Registered Cable Address, "Pinewood." "American Lumberman" Telecode

B. C. RED CEDAR SHINGLES

Several cars now in transit, hence can give prompt delivery.

SEND IN YOUR ORDERS

C. A. LARKIN - - Toronto

J. D. SHIER LUMBER CO., LIMITED
BRACEBRIDGE, ONT.

MANUFACTURERS OF
LUMBER, LATH AND SHINGLES

Pine, Hardwood and Hemlock Floorings and Ceilings, Sash and Doors, Wood Turnings etc. All Dressed Lumber Kiln Dried if desired End Matched Flooring a Specialty.

GOOD PINE SIDINGS A SPECIALTY

Planing, Matching, Resawing, etc
in Car Lots.

Manufacturer of
Doors, Sash, Mouldings, Ceilings
End-Matched and Bored
HARWOOD FLOORING
A SPECIALTY.

Lumber Kiln Dried in Any Quantity.
J. R. EATON - Orillia, Ont.
Correspondence Solicited. Phone No. 54.

CEDAR POLES

5,000 pieces, 10 to 20' long. Suitable for Hops, etc.
Price?—Well write us.

THE LONG LUMBER COMPANY
HAMILTON

CACHE BAY LUMBER INDUSTRIES.

Geo. Gordon & Co.,
Manufacturers of RED and WHITE PINE

Band - Gang LUMBER
Circular AND LATH

CACHE BAY, Ont.
C. P. R. 26 miles West North Bay

BANK ST. CHAMBERS OTTAWA, ONTARIO

W. B. BARTRAM

WHOLESALE LUMBER AND TIMBER MERCHANT

White Pine, Quebec Spruce and Hardwood.
Special Bills sawn on short notice. Barge or car load lots
All Inquiries Given Prompt Attention.

J. GORDON MACLAREN

HINTONBURG, ONT.

DIMENSION TIMBER { In Spruce, White and Red Pine, up to 40 feet.
In Douglas Fir, up to 90 feet.

Every inquiry receives our Prompt attention.
Write for quotations. B. C. Cedar Shingles
SASH - DOORS - BLINDS

Please mention this paper when corresponding with advertisers.

CARTER POWELL LAND & LUMBER CO., LIMITED

604 Temple Building, Toronto

To **MILLMEN**—Cash buyers all kinds **HARDWOODS**

Cable address "Quartered Toronto." Codes, A. B. C., 5th and Lumberman's

Cedar Cove Mill,
Vancouver, B.C.

E. H. HEAPS & CO.,
Vancouver, B. C.

Ruskin Mill
Ruskin, B. C.

Lumber, Lath, Shingles, Doors, Mouldings, Etc.

SPECIALTIES :

AA1 HIGH GRADE CEDAR SHINGLES.

Cedar Bevelled Siding, Cedar Door and Sash Stock, cut to size, Cedar Finish, Base, Casing, Newels, Balusters, etc. Douglas Fir Timber up to 85 feet in length.

W. J. SHEPPARD, PRESIDENT
Waubaushene, Ont.

J. G. SCOTT, GENERAL MANAGER
Vancouver, B.C.

Pacific Coast Lumber Co.

LIMITED
VANCOUVER, B.C.
MANUFACTURERS OF

**Fir, Cedar and Spruce Lumber, Lath, Mouldings, Turned Work, Etc.
High Grade Red Cedar Shingles**

Ontario Representative, W. J. LOVERING,

112 Mail Building, TORONTO

D. C. CAMERON, President and Manager.

WM. ROBERTSON, Secretary.

J. E. YOUNG, Cashier

The Rat Portage Lumber Co., Ltd.

Manufacturers
of

**White and Red Pine Lumber, Lath, Shingles, Sash,
Doors, Turned and Band Saw Work**

Dealers in CEDAR POSTS, POLES and TAMARAC PILING

Mills at RAT PORTAGE and RAINY RIVER, Ontario, WINNIPEG, Manitoba, and VANCOUVER, British Columbia. Head Office: RAT PORTAGE, Ontario

Our Vancouver Mill cuts High-Grade Cedar, Fir, Spruce and Red Cedar Shingles. Winnipeg Mills cut Pine, Tamarac and Spruce Lumber
We also Manufacture all kinds of Mouldings, Sash, Doors, Turned Work and Boxes. Correspondence solicited at all four points.

**Export Lumber &
Shingle Co., Limited**
Vancouver, B. C.

We are Exclusive Selling Agents in Canada
for 40 per cent. of the Shingles manufac-
tured in British Columbia. Daily shipping
capacity over 1 1/4 millions.

W. C. WELLS 
PALLISER, B. C.

Manufacturer of
High Grade Spruce, Fir, Cedar
and Lumber of all Descriptions.
CORRESPONDENCE SOLICITED.

W. B. MCKECHNIE, President.

C. MACRAE, Manager.

THE ALBERTA LUMBER CO.
Vancouver, B. C. LIMITED

Manufacturers of
BRITISH COLUMBIA RED CEDAR

All sizes to 24 inches wide, by 24 feet long—CLEAR.
B. C. FIR—DIMENSION AND FINISH.

SCRIBNER'S LUMBER AND LOG BOOK

A handy book for Lumbermen. Gives Correct Measurements
of Scantlings, Boards and Planks; Cubical Contents of Square
and Round Timber; Doyle's Rules, and much other practi-
cal information.

Price 35 Cents

ADDRESS THE CANADA LUMBERMAN, TORONTO, ONT.

CANADIAN MANUFACTURERS and WHOLESALERS

THE PEMBROKE LUMBER CO.
PEMBROKE, ONT.

We make a specialty of Dimension Stock in Pine, Spruce and Hemlock, and solicit your enquiries.

DELAPLANTE - McBURNEY LUMBER CO.,
WHOLESALE

White Pine, Hemlock, Lath, Shingles

Stocks in at { Collingwood Powassan Cartier Callander
Ontario { Midland Whitney Sturgeon Falls North Bay

TORONTO OFFICE: Room 503 Manning Chambers.

Office, Yards and Docks, NORTH TONAWANDA, N. Y. Send us your enquiries

FOR Pine, Hemlock, or Hardwood, Lumber and Timber, Telegraph Poles, Ties, Posts, Lath, Shingles, Dressed Lumber, Sash, Doors, Interior Finish, End Matched and Bored Hardwood Flooring, etc., try

JOHN HARRISON & SONS COMPANY, LIMITED

We have a complete stock, two Saw Mills running in summer and one all winter.
HEAD OFFICE, SAW AND PLANING MILLS, OWEN SOUND, ONT.

RHODES, CURRY & CO., Limited
LUMBER MERCHANTS.

Yards at Amherst, Little Forks, Sydney and Halifax.
BUILDING MATERIAL of all kinds carried in stock. We are buyers of Ontario Basswood, Elm and Pine.
Amherst, N.S.

Sawn and Hewn Spruce, Hemlock, Pine and Birch Timber, Spruce and Pine Boards and Plank, Birch and Ash Boards and Plank, Flooring, Shingles, etc.

JAMES J. MURPHY, Bank of Hochelaga Building **QUEBEC**

The Cook & Bros. Lumber Co. MANUFACTURERS OF
Of Ontario, Limited
MILLS at SPRAGGE, Algoma Dist., Ont. on "Soo" Branch C. P. R.
OFFICES { Manning Arcade, Toronto
Cristine Building, Montreal
And at Mills at Spragge.
White and Red Pine Lumber and Lath
Water Shipments

THE M. BRENNEN & SONS MANUFACTURING CO., LIMITED

Saw Mills at RAINY LAKE, Ontario. Planing Mill and Head Office: HAMILTON, Ontario.

THE NIPISSING LUMBER COMPANY, LIMITED

Mills at CACHE BAY and SPANISH RIVER, Ontario.

Manufacturers of and Wholesale Dealers in all kinds of LUMBER AND LATH

Both Railway Delivery and Water Shipments. Correspondence Solicited. The NIPISSING LUMBER CO., Limited Head Office: HAMILTON ONT.

AUGER & SON - Quebec
PULP WOOD AND TIES

Bought at Any Station.
Also Dimension Timber, Sawn to Sizes, Telegraph Poles and Lumber.—Write Us.

A. F. BURY AUSTIN
WHOLESALE LUMBER and TIMBER
CANADA PINE

Bank of Ottawa Building, 224 St. James St., - MONTREAL, CANADA
SPECIALTIES: Railway Bridge Timber and all kinds of Hardwoods; Ship Decking, Norway and White Pine, Dimension Timber, Norway Car Sills, Car Flooring, Telegraph Poles, Railway Ties, Oak and Whitewood, Planed and Rough Lumber, British Columbia Pine, Southern Pine, &c.; Birch Flooring, hollow back, end butted.

Eastern Agent for The Pacific Coast Lumber Company, Limited, Vancouver, B. C.
Douglas Fir Timber in any size or length up to 90 feet long. Timber Planers face up to 24 inch x 30 inch Dry Kilns of large capacity. Rough and Dressed Lumber, Douglas Fir and Cedar.

WRITE FOR PARTICULARS AND QUOTATIONS.

R. LAIDLAW LUMBER CO.
18 Toronto Street, Toronto

JAS. PLAYFAIR. D. L. WHITE.
PLAYFAIR & WHITE
Manufacturers and Wholesale Dealers
LUMBER • LATH • SHINGLES

Contractors for Railway Supplies BILL TIMBER a Specialty MIDLAND, ONT.

A. & P. WHITE Manufacturers of and Dealers in
Sawn and Planed Lumber, Dimension Timber. Joisting Car Sills, Car Flooring, Shingles and Lath.
PEMBROKE ONT.

GET YOUR LUMBER AND TIMBER FROM
PINE LUMBER COMPANY
(On C. P. R. Main line near Sudbury) PINE, ONT.

F. MCGIBBON & SONS, PENETANGUISHENE ONT.
Manufacturers of Pine, Hemlock and Hardwood Lumber, and dealers in Cordwood Hemlock Bills cut on short notice.

MAITLAND, RIXON & CO. OWEN SOUND, ONTARIO.
Manufacturers and Dealers
LUMBER LATH, TIES, POLES, SHINGLES, ETC.
Make a Specialty of Long Pine, Cedar and Hemlock Bill Stuff. We ship by C. P. R., G. T. R., and by Water.

Turner Lumber Co., Limited MANUFACTURERS
LUMBER and LATH
Shipments by Rail or Water. Midland, Ont.

HARDWOOD FLOORING

End Matched, Bored, Steel Polished, and Bundled
Send for Price List
A few cars of selected Maple and Birch and other Hardwoods at close price
THE SEAMAN KENT CO., Limited
160 Bay St. Toronto Factory, Meaford, Ont.

THE FOSS LUMBER COMPANY

WHOLESALE
BRITISH COLUMBIA FIR, SPRUCE AND CEDAR LUMBER, RED CEDAR SHINGLES
We Solicit Your Enquiries.
J. F. FOSS, Manager. 624-625 Union Bank, Winnipeg, Man.

HARDWOOD FLOORING

MANUFACTURED IN
MAPLE, BIRCH, BEECH AND OAK
3/8, 5/8, 7/8, 1 1/8 and 1 3/8 inch thicknesses. Kiln-Dried, Hollow Backed, End Matched, Bored and Polished, bundled with wire baling. . . .
Also Stock fully machined for Spring Bed Frames
and
ALL KINDS OF HARDWOOD LUMBER
J. S. FINDLAY • OWEN SOUND, ONT

BRITISH COLUMBIA TIMBER IN DEMAND.

American capitalists close to the management of the Grand Trunk Pacific Railway are reported to be seeking to acquire extensive timber lands on Moresby Island, the southerly island of the Queen Charlotte group, in British Columbia. Within the next thirty days application will be made to the Chief Commissioner of Lands and Works for permission to cut the timber on 107 square miles of land on Moresby Island. For each square mile so taken up the Government fee will be \$140 per annum.

The identity of the capitalists behind the applicants for this land is unknown beyond the fact that they are Americans. It is supposed in some quarters that the McGoldrick interests of Ohio may be the background applicants, but this is only surmise, and is largely based on the fact that the Ohio people have recently acquired hundreds of square miles of timber lands from the coast right through to Pine River Pass along the route tributary to the Grand Trunk Pacific line.

An extensive acreage of timber limits on Stuart and Fraser Lakes has been taken up by a number of Vancouverites. These lakes are not far from Fort George, and presuming that the Grand Trunk Pacific enters the province through the Pine River Pass, it will have to swing along toward the sea coast by the Nechaco, Endaco and Bulkley Rivers, and so the timber bordering on Stuart and Fraser Lakes and through all the country in that vicinity will be tributary to the new line.

The Vancouverites who are paving the way to the ownership of the timber lands along the proposed transcontinental route are Messrs. Robert Kelly, F. C. Wade, K.C., G. I. Wilson and J. Y. Rochester.

BRITISH LUMBER PRICES.

The following prices were realized for Canadian deals, etc., at an auction sale held by Foy, Morgan & Company, London, England, on July 19th:

PINE—Ex. Kildona, from Montreal—14-16 ft. 3 x 11 in. first quality red, £15 per standard of 1,980 ft.; 12-16 ft. 3 x 11, £15 10s; 14-17 ft. 3 x 10, £14 15s; 14-17 ft. 3 x 9, £15; 14-16 ft. 3 x 9, £14 15s; 12-16 ft. 3 x 9, £14 15s; 14-16 ft. 3 x 11 in. second quality red, £10 5s; 12-16 ft. 3 x 11, £10 10s; 14-16 ft. 3 x 10, £9 10s; 14-16 ft. 3 x 9, £9 15s and £10; 13-17 ft. 3 x 9, £9 15s. Ex. Hurona, from Montreal—8-16 ft. 3 x 11 in. first quality red, £16; 12-17 ft. 3 x 9, £15; 11-16 ft. 3 x 11 in. second quality red, £10; 13-16 ft. 3 x 9, £9 15s.

SPRUCE—Ex. Cunaxa, from West Bay, N.S.—14 ft. 3 x 12 in. unassorted, £7 10s. Ex. Irene, from Matane and Rimouski, Que.—11-16 ft. 3 x 9 in. unassorted, £8 5s; 13 ft. 3x9, £8 10s and £8 15s; 9-11 ft. 3x9, £8 15s; 3-8 ft. 3x7 in. unassorted, £7; 4-8 ft. 3x6, £16 17s 6d; 5-8 ft. 3x11, £7 15s; 4-8 ft. 3x9, £7 15s; 4-8 ft. 3x8, £7 10s; 4-8 ft. 3x6, £6 15s. Ex. Halifax City from St. John—9-19 ft. 3x7 in. unassorted, £7. Ex. St. John City, from Halifax—3-20 ft. 3x9 in. unassorted, £7 5s. Ex. Montezuma, from Quebec—7-14 ft. 3x6 in. first quality, £9 15s.

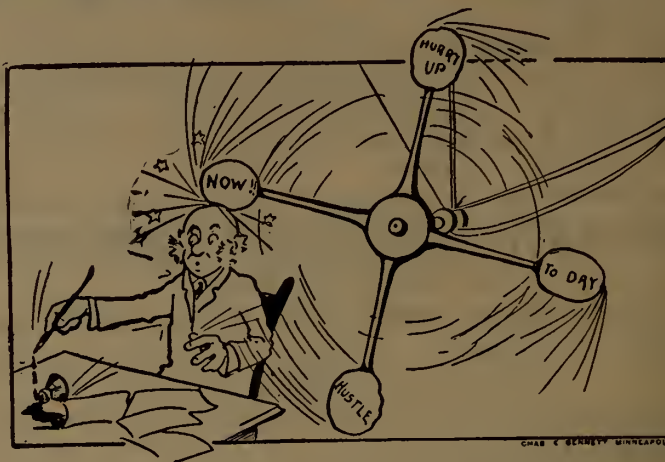

JUST A GENTLE REMINDER

That's all--a reminder that we can supply your wants in the lumber line. It's up to you NOW to realize that fact and to open up correspondence with us. Don't forget that **SPRUCE LUMBER** is our specialty--and should be yours. Let us tell you why.

The Red Deer Lumber Company
WINNIPEG, MAN.

UNITED STATES MANUFACTURERS AND WHOLESALERS

YOU
CAN
REACH

THE BONSACK LUMBER CO.
WHOLESALE HARDWOODS
ST. LOUIS
BY
RAIL, MAIL
WIRE OR
'PHONE

YELLOW PINE

We are in position to give first - class stock. Reasonable prices. Prompt shipments. Mills in Alabama, Mississippi and Arkansas.

MANN, WATSON & CO. Muskegon, Mich.

H. D. WIGGIN BOSTON, MASS.
89 STATE ST.

will inspect at mill and PAY CASH for

LOG RUN

Elm, Ash, Bass and other Hardwood

CORRESPONDENCE SOLICITED.

Is it your wish . . .

To Purchase or Sell as quickly as possible
A PARTICULAR LOT OF LUMBER
A MILL PROPERTY
SECOND-HAND MACHINERY

An Advertisement in the "Wanted" and "For Sale" Department of the **CANADA LUMBERMAN WEEKLY EDITION**

Will secure for you a Buyer or Seller, as the case may be. Address, The Canada Lumberman, Toronto

THE ROBERT H. JENKS LUMBER CO.
CLEVELAND, OHIO

MANUFACTURERS AND WHOLESALERS OF

YELLOW PINE, POPLAR, HEMLOCK AND HARDWOODS

Yellow Pine Timbers a Specialty

Indiana Lumber & Veneer Co.
INDIANAPOLIS, IND.

Sawed and Sliced Quartered
Oak a Specialty

Correspondence Solicited. <<<<<

Veneers

McGLURE LUMBER CO.

Wholesale Dealers in . . .

Hardwood Lumber

Carry in Stock and Have for Sale

ASH, BASSWOOD, BEECH, BIRCH, BUTTERNUT, CHERRY, CHESTNUT, COTTONWOOD, CYPRESS, ELM, GUM, HICKORY, MAHOGANY, MAPLE, OAK, POPLAR, SYCAMORE, WALNUT, POLES (Oak, Hickory and Ash), RIMS and SPOKES (Oak and Hickory), OAK BENDING PLANK, OAK BILL STUFF, RAILWAY TIES.

Office and Yards: 520 to 530 Franklin St., DETROIT, MICH.

Correspondence Invited on All Hardwoods.

FRANK C. BURY

BURY & NOBLE

MASON A. NOBLE

WHOLESALE

LUMBER - DETROIT

MICHIGAN

Send us your inquiries for Southern Yellow Pine.

THE HARDWOOD DEMAND.

Contrary to anticipation, says the Hardwood Record of Chicago, the general hardwood lumber demand from one end of the country to the other has exhibited a marked improvement during the last two weeks—an improved condition in inquiry and actual ordering forward of stock that comes fully a month earlier than was expected even by the optimistic.

In the South weather conditions still remain unfavorable for the getting out of oak and many other varieties of hardwoods, and it is practically certain that oak values, especially in plain wood, will outstrip the highest prices paid early in the spring.

In Michigan and Wisconsin black ash has become so scarce as to be almost out of the market.

Maple, while in less aggregate supply than a year ago, is moving rather slowly. The flooring makers have consumed the big end of the inch, but there seems to be a little overstock of thick lumber.

The good end of basswood is moving very well indeed, and there is a special call for winter sawed, end piled, strictly white. The coarse end of the wood is dragging.

Rock elm is very scarce and ranging

high in value, and in many instances completely out of stock.

Good birch, especially that showing a fair proportion of red, is in strong demand generally in Michigan, while some of the Wisconsin dealers report it dragging.

Grey elm, an exceptionally good wood, for some strange reason is not meeting the expectation of producers in volume of demand. Some dealers claim that the price was boosted too high early in the year and that many consumers have substituted gum and other woods in its place.

The good end of poplar is still doing first rate, while the common and coarse end is dragging more or less.

There seems to be an increased demand for quarter sawed oak, and apparently there has been less of this sawing produced than last year, which would augur a prospect for increased values. Plain oak, however, still has the call in the market, and buyers generally are recognizing that buying plain wood at any reasonable price constitutes a good purchase.

CANADIAN LUMBER SHIPMENTS.

From Montreal: Steamer Lake Champlain, for Liverpool, 27,121 pcs. deals, 2,157 pcs. boards, 2,860 pcs. ends, 407 pcs. plank, 1,925 pcs. lumber, 4,026 bcls.

lumber, 2,730 bcls. shooks. Steamer Hurona, for London, 860 pcs. deals, 493 bags birch squares. Steamer Lake Michigan, for London, 18,920 pcs. boards, 19,632 pcs. deals, 5,391 pcs. plank, 13,978 pcs. lumber, 2,531 bcls. lumber, 283 logs. For Antwerp, 10,034 pcs. deals. Steamer Sardinian, for London, 2,079 pcs. lumber. Steamer Englishman, for Bristol, 4,908 pcs. deals, 900 doors. Steamer Ionian, for Glasgow, 6,615 pcs. deals, 10,400 pcs. boards, 191 logs, 2,663 bcls. maple strips. Steamer Salacia, for Glasgow, 811 pcs. lumber, 752 pcs. planks, 400 pcs. boards, 5,565 pcs. deals, 368 pcs. ends. Steamer Bengore Head, for Dublin, 1,000 bcls. staves.

From St. John, N. B.: Schooner Estelle, for New York, 2,039,000 laths. Schooner Harold B. Cousins, for New York, 347,588 ft. plank, 94,523 ft. scantling. Schooner H.A. Holder, for Boston, 97,970 ft. boards, 25,000 laths, 10,500 clapboards, 250,000 cedar shingles. Schooner W. E. and W. L. Tuck, for New York, 222,951 ft. deals, 58,723 ft. scantling. Ship Elsie, for Dublin, 975,255 ft. deals, 43,551 ft. ends. Schooner Walter Miller, for Boston, 107,300 ft. boards, 550,000 shingles. Steamer Pydna, for Brow Head, 1,983,248 ft. deals and battens, 153,255 ft. scantling, 105,653 ft.

ends, 186,413 ft. boards. Schooner Rosa, for Tralee, 499,368 ft. deals, 53,570 ft. scantling, 39,347 ft. ends. Schooner H. M. Stanley, for Salem, 124,000 ft. hemlock, 800,000 laths. Steamer Lewisport, for Brow Head, 1,477,123 ft. deals, 377,700 ft. scantling, 47,101 ft. ends. Schooner Tay, for Providence, R. I., 123,183 ft. plank, 59,681 pcs. lumber. Schooner Aldine, for City Island, 401,305 ft. deals, 4,025 ft. plank. Schooner Clayola, for New York, 960,000 laths. Schooner Romeo, for New Have, 70,353 ft. plank, 79,288 ft. scantling, 8,788 ft. boards.

From Halifax, N. S.: Steamer Veritas, for Jamaica, 6,933 ft. pine lumber, value \$121; 5,000 ft. spruce lumber, value \$75, by A. G. Jones & Co., agents. Barque Ceasar, for Ipswick, G. B., 419,890 ft. spruce deals, value \$4,700. Barquentine Fremad, for Dundalk, Ireland, 323,701 ft. spruce deals, value \$4,162. Barque Hugo, for Swansea, G. B., 298,158 ft. birch deals, value \$3,204; 460,810 ft. spruce deals, value \$5,435, by W. M. McKay, agents. Barque Alastor, for Swansea, G. B., 297,836 ft. birch deals, value \$3,370; 434,854 ft. spruce deals, value \$5,022, by W. M. McKay, agent. Steamer London City, for Liverpool, 1,009,396 ft. spruce deals, value \$12,940; 177,869 ft. birch deals, value \$2,419; 97,378 ft. hemlock deals, value \$857, by Furness, Withy & Co., agents. Brigantine Venture, for New York, 218,332 ft. hemlock scantling, value \$2,400; 239,500 laths, value \$503, by G.P. Mitchell & Son, agents. Steamer Angola, for Cuba, 71,841 ft. spruce boards, value \$1,075, by T. A. S. De Wolf & Sons, agents.

BRITISH WOOD BROKERS AND IMPORTERS

FARNWORTH & JARDINE
Wood Brokers and Measurers
 Cable Address "Farnworth," Liverpool. 5 Dals St., 71 Regent Road BOTTLE, LIVERPOOL, ENC.

F. A. Lightbody & Co.
 3 Gordon Street - GLASGOW, SCOTLAND
WOOD BROKERS
 Cable Address; "TENEBRIS," GLASGOW. Codes: A. B. C., A 1, "Zebra" and Private.
 Agents for CANADIAN WHITE PINE AND SPRUCE; Hardwoods in Log; Etc.
 Shipments handled to the best advantage to all ports in the United Kingdom. Correspondence Solicited.

LOUIS BAMBERGER, 2 Broad Street Building, LONDON, E. C.
 IMPORTER OF Pine, Spruce and all Canadian Wood Goods
 Telegraphic Address "Bellywood, London."
 Are Open to Contract for Glued-Up BASSWOOD KEYBOARDS

GELLIBRAND, HEYWOOD & CO.
 Wood Agents and Brokers
 Cable Address: "GELLICHT," LONDON 57 Gracechurch St. London, E.C. England

FELBER, JUCKER & CO.
 Lumber Importers
 MANCHESTER ENGLAND
 Invite offers from Lumbermen for . . .
 Spruce Deals and Battens, Spruce and Pine Floorings, Shooks, Sashes, Mouldings, Dowels, Broom Handles, Chair Stock, Seats, etc., or any Woods Suitable for English Market.
 Telegraphic Address: FELBER MANCHESTER.

ASHTON & PETFORD
 BISHOP LANE, - HULL, ENGLAND
BUYERS OF BOX SHOOKS
 Invite correspondence from manufacturers who are in a position to export to Great Britain.
 Cable address, "Shooks," Hull.
 Codes—A. B. C. 4th Edition and Zebra.

JAMES WEBSTER & BROTHER
 BOOTLE, LIVERPOOL, ENGLAND
TIMBER MERCHANTS
BUYERS OF Oak, Birch, Ash, Grey Elm Logs and Lumber, Elm Staves and Heading, Handica of all descriptions
 Veneers A Specialty

SMITH & TYRER - 14 Tithebarn Street, LIVERPOOL
.. WOOD AGENTS ..
 Cable Address—"Walmer," Liverpool.
 Halifax, N.S., Office—SMITH, TYRER & CO., Metropole Bldg., Hollis St. Halifax, N.S.

Edmiston & Mitchells
TIMBER BROKERS
 Cable Address: "EDMISTON" Glasgow. 33 Renfield Street, GLASGOW

GANT & KEMP  **TIMBER BROKERS**
 52 St. Enoch Square, GLASGOW
 Cable Address: "TECTONA" Glasgow.
 A1 and A B C Codes used.

Telegrams and Cables: "Woodfeller, London."
 Codes: Zebra, Western Union, Southards, and A. B. C. 4th and 5th Editions.
THOMPSON, BLOIS & CO.
 Buyers of all Kinds of Lumber and Logs
 17 GRACECHURCH STREET: LONDON, E. C.
 Cash advances made against shipping documents.
 Branches: MANCHESTER, HAMBURG.

JOSEPH OWEN & SONS, LTD.
 Timber Importers
 Cable Address "Owen Liverpool" Liverpool, Eng.
BUYERS OF
 White Ash Logs and Planks.
 Oak Logs and Planks.
 Rock Maple Logs and Planks.
 Rock Elm Logs.
 Hickory Logs.
 . . . ALSO . . .
 All classes of Lumber and Manufactured Wood Goods suitable for the English Market.

ALFRED DOBELL & COMPANY
WOOD AGENTS AND BROKERS
 Liverpool and London Chambers - LIVERPOOL, ENGLAND
 CABLE ADDRESS "DOBLE LIVERPOOL."

THE ONTARIO LUMBER CO. LIMITED

MILLS: North Bay, C.P.R. and G.T.R. Delivery.

WHITE PINE LUMBER, LATH AND SHINGLES.

35 and 36 Home Life Building TORONTO, Ont.
MILLS: French River, Georgian Bay
Water Shipment Only.

PEDWELL & LEMCKE, Lions Head, Ontario

MANUFACTURERS OF Pine, Hemlock and Hardwood Lumber, Shingles, Ties, Poles, Posts, Etc.
Rail or Water Shipments. Correspondence Solicited.

CANADIAN LUMBER WANTED

We solicit consignments of long and short lumber from the Maritime Provinces and are prepared to purchase White Pine and Hardwoods in Ontario and Quebec.

ADDRESS:

CHAS. S. WENTWORTH & CO.
Room 510, 147 Milk St. - BOSTON, MASS.

THE KING AND BARTLES LUMBER CO. PINE, POPLAR AND HARDWOODS

HEADQUARTERS: Citizens' Building, Cleveland, O.
HARDWOOD: Distributing Yard, McMinnville, Tenn.
We buy and sell Pine in Car and Cargo Lots

McLennan Timber Land and Lumber Co., Limited

Selling Agency and Dealers in all kinds of Timber Lands.
Offices: Quebec, 131 St. Peter St. Ottawa, Room 9, Central Chambers.

GEO. G. GLADMAN MANUFACTURER OF WHITE PINE AND HEMLOCK LUMBER LATH AND SHINGLES

Mills at Smith's Bay Township of Carling

PARRY SOUND, ONT.

CORRESPONDENCE SOLICITED

WE have Three Millions of Hemlock, running in lengths from 10 to 24 feet, which we are prepared to cut in blocks of 50,000 feet or over.

THE WOODSTOCK LUMBER & MANUFACTURING CO.

Dealers in Pine, Hemlock and Hardwood Lumber..

WOODSTOCK, ONTARIO

A. P. EBERT

MANUFACTURER OF AND DEALER IN

Pine and Hardwood Lumber, Lath, Shingles, Posts, Broom Handles, and Short Hardwood Dimension Stock

WIARTON, ONT.

THE NEW LINE

Through the Spruce Forests of the Laurentian Mountains—between Quebec and Hawkesbury.

WATER-POWERS, TIMBER LIMITS AND ELECTRIC POWER FOR SALE. IDEAL PULP-MILL SITES.

Unexcelled Export Facilities at Quebec.

A. J. GORRIE, General Supt.

MONTREAL

GUY TOMBS G. F. & P. A.



CURRENT LUMBER PRICES--WHOLESALE

TORONTO, ONT.

CAR OR CARGO LOTS.

1 inch No. 1 Pine cuts & better.....	\$47 00 \$49 00	2x4 to 10 in. 10 to 16 ft. 15 00 16 00	2x4 to 10 inch, 18 ft. 16 00 17 00
1 1/2 to 2 inch No cuts and better	5 00 51 00	Clear inch B. C. cedar, kiln dried.....	50 00
1 1/2 & 2 in. No. 2 Pine cuts and better.....	42 00 44 00	Clear inch B. C. cedar air dried boat lumber	55 00
1 1/2 to 2 inch No. 3 cuts and better.....	37 00 38 00	Douglas fir dimension timber, 25 to 30 feet	30 00
1 in Pine Dressing and better shorts	24 00 25 00	Douglas fir dimension timber, 30 to 35 feet	31 00
1x4, 6 and 8 common	18 00 19 02	1 1/2 in. No. 1 4 ft. Pine Lath.....	3 50 3 60
1x10 common.....	19 50 20 00	1 1/2 in. No. 2 4 ft. Lath	3 00 3 10
1x12 common.....	21 00 22 00	1 1/2" No. 1 3 1/2" pine lath	1 70
1x10 common.....	20 00 21 00	1 1/2" No. 1 4 ft. hemlock lath	2 80
1x10 common.....	21 00 22 00	XXXX Pine Shingles	2 90 3 00
1x10 inch box and common	20 00 21 00	XX Pine Shingles..	2 10 2 20
Inch mill run sidings	21 00 22 00	X Pine Shingles..	90
1 in. mill run.....	20 00 21 00	XX Cedar Shingles	2 20 2 25
1x10 and 12 mill culls	16 00 17 00	B. C. Shingles	2 90
1 inch mill cull Sidings.....	15 00 16 00	XXX 6 butts to 2 in.	3 12
1 in. dead cull sidings	12 00 13 00	XXXX 6 to 23-16 in.	3 45
1 1/2 inch Flooring	24 00 25 00	XXX No. 2, 6 to 2 in. }	2 30
Hemlock, 1x4 to 8 in.	14 50 15 50	XX " 6 to 23-16 in. }	2 30

HARDWOODS--PER M. FEET CAR LOTS.

Ash White, 1 to 2 in	33 00 35 00	Elm, rock, mill run.....	1 to 1 1/2" 24 00 26 00
Ash, black, 1sts and 2nds.....	27 00 29 00	Elm rock, mill run.....	1 1/2" 3.. 29 00 30 00
Birch M. R., 1 in.....	21 00 22 00	Hickory, 1sts and 2nds.....	1 1/2" 2.. 36 00 38 00
1 1/2" 2.. 23 00 25 00		Maple 1" mill run.....	1 1/2" 20 00 21 00
1 3/4" 2.. 24 00 26 00		Maple, 1sts and 2nds.....	2 " 4.. 24 00 26 00
Basswood, Common and better 1 to 1 1/2 in	24 00 25 00	Oak; red, p'n, 1sts & 2nds	2 " 4.. 44 00 46 00
Basswood, 1 1/2 to 2..	25 27 00	Oak, white, 1sts & 2nds	1 " 1 1/2 42 00 44 00
m. r. 1 " 1 1/4 24 00 26 00		Oak, white, 1sts & 2nds	2 " 4.. 45 00 50 00
Cherry, 1sts and 2nds..	1 " 1 1/2 55 00 60 00	Oak, quart'd, 1sts & 2nds	2 " 70 00 80 00
Cherry, 1sts and 2nds..	2 " 4.. 60 00 70 00	Walnut, 1sts and 2nds..	1 " 3.. 85 00 100 00
Elm, soft, mill run.....	1 " 1 1/2 24 00 25 00		
Elm, soft, mill run.....	2 " 3.. 25 00 26 00		

QUEBEC, QUE.

WHITE PINE--IN THE RAFT

Square white pine, measured off, 30 to 40 feet average.....	35 45
First class Ottawa waney, 18 inch average, according to lineal..	60 65
19 to 20 inch average " " "	62 65

RED PINE--IN THE RAFT.

Measured off, according to average and quality.....	27 33
Shipping order " " "	35 40

OAK--MICHIGAN AND OHIO.

By the dram, according to average and quality ..	50 56
--	-------

ELM.

By the dram, according to average and quality 40 to 45 feet ..	65 75
" " " 30 to 35 feet ..	52 54

ASH.

10 inches and up, according to average and quality ..	26 26
Average 16 inch ..	30 30

BIRCH.

14 Inch ..	20 22
16 " " ..	26 28
17 " " ..	28 31
18 " " ..	32 34

OTTAWA, ONT.

MANUFACTURERS' PRICES.

Pine, good sidings: 1 in. x 8 in. and up	39 00 42 00	1x10 No. 1 barn.....	21 00
1 1/2 in x 1 1/2 in. x	50 00 54 00	1x10 No. 2 "	19 00
8 in. and up.....	50 00 54 00	1x8 & 9 No. 1 barn.....	19 00
2 in. x 8 in. and up	52 00 56 00	1x8 & 9 No. 2 "	17 00
		Pine Shorts 6' to 11' x 8"	15 00

Pine good strips : 1 in.....	33 00 36 00	Pine shorts 6' to 11' x 10"	16 00
1 1/2 in. and 1 1/4 in.....	36 00 38 00	Pine, 8 up s. c. sidings	16 50 20 00
2 in.....	38 00 40 00	Pine s. c. strips.....	13 00 15 00
Pine, good shorts: 1 in.....	25 00 28 00	Pine, s. c. shorts.....	12 00 14 00
1 1/2 in. and 1 1/4 in. ..	28 00 35 00	Pine, box boards.....	14 50
2 in.....	34 00 38 00	Pine mill culls.....	13 00 14 00
Pine, No. 1 dressing siding, per M feet, b.m.....	20 00 25 00	Lath, per M	
Pine, No. 1 dressing strips.....	18 00 24 00	No. 1 white pine:..	2 40 2 60
Pine No. 1 dressing shorts.....	16 00 20 00	No. 2 white pine: ..	2 00 2 25
Pine, ro s. c and better stock, 12' to 16'	20 00 22 00	Spruce, mill run.....	2 00 2 15
Pine, 8 s. c. and better stock, 12' to 16'.	17 00 19 00	Red Pine, mill run..	2 00 2 15

SARNIA, ONT.

UPPERS. 1 in., 10" and up wide.....	\$73 00	1 1/2 x 4 and 5".....	\$21 00
1 1/2, 1 1/2 and 2" " ..	73 00	1 1/2 x 6" and up.....	24 00
2 1/2 and 3" " ..	78 00	1 1/2 x 10 1/2.....	25 00
4" " ..	83 00	1 1/2 x 12".....	27 00
SELECTS. 1 in., 8" and up wide.....	63 00	1 1/2 x 6" and up.....	24 00
1 1/2, 1 1/2 and 2" " ..	63 00	1 1/2 x 10".....	25 00
2 1/2 and 3" " ..	73 00	1 1/2 x 12".....	27 00
4" " ..	78 00	2" x 6" and up.....	25 00
FINE COMMON. 1 in., 6" and up wide.....	20 00	2" x 10".....	26 00
1 1/2 and 1 1/2" " ..	33 00	2" x 12".....	28 00
1 1/2 and 2" " ..	36 00	NO. 1 BARN. 1 in.....	\$23 00 to \$30 00
2 1/2, 3 and 4" " ..	45 00	1 1/2, 1 1/2 and 2" ..	28 00 to 31 00
NO. 1 CUTS. 1 in., 8" and up wide.....	33 00	2 1/2 and 3".....	32 00
1 1/2 in. " ..	46 00	4" ..	35 00
1 1/2 in. " ..	46 00	NO. 2 BARN. 1 in.....	20 00 to 24 00
2 1/2 and 3" " ..	60 00	1 1/2, 1 1/2, 2 and 2 1/2".....	22 00 to 23 50
4" " ..	62 00	3" ..	26 00
NO. 2 CUTS. 1 in., 6" and up wide.....	20 00	NO. 3 BARN. 1 in.....	17 00 to 20 00
1 1/2 and 1 1/2" " ..	33 00	1 1/2, 1 1/2 and 2" ..	18 00 to 20 50
1 1/2 and 2" " ..	36 00	3" ..	21 00
2 1/2, 3 and 4" " ..	45 00	BOX. No. 1, 1", 1 1/2,	
NO. 3 CUTS. 1 in., 6" and up wide.....	18 00	1 1/2, 2".....	13 50 to 18 00
1 1/2 and 1 1/2" " ..	20 00	No. 2, 1", 1 1/2,	
1 1/2 and 2" " ..	33 00	1 1/2 2".....	14 50 to 17 00
2 1/2, 3 and 4" " ..	45 00	MILL CULLS. Mill Run 1", 1 1/2, 1 1/2 and	
MILL RUN. 1" x 4".....	18 00	2" ..	13 00
1" x 5".....	19 00	No. 2, " " " " " "	11 00
1" x 6 and 8".....	20 00	LATH. No. 1, 4 3/8" pine.....	3 25
1" x 10".....	22 00	No. 1, 3 1/2" " ..	1 00
1" x 12".....	23 00	No. 2, 4 3/8" " ..	2 75
1" x 13 and np.....	25 00	SHINGLES. XXX W.P. or W. Cedar,	

ALBANY, N.Y.

Uppers, 3 in.	83 85	1x12 inch shippers	\$ 24
2 1/2 in.	83 85	4/4 inch " " " " " "	25
1 to 2 in.	78 80	4/4 Box boards 6" and up ..	19 20
1 inch uppers	88 90	10-in. dressing and better... 30	35
Selects, 2 1/2 in up.....	77 82	12-in. dressing and better... 40	42
1 to 2 in.....	79 72	Box, 1x10-in.	21
1 in to 2 in.....	72 75	Box, 1x12	21
No. 1 cuts, 1 to 2 inch.....	53 55	No. 1 barn, 1x12.....	29 30
No. 2.....	55 55	1x10	25 26
No. 3.....	30 35	1x8	25
No. 1 molding, 1 to 2 in.....	48 50	No. 2 barn, 1x12.....	26 27
No. 2 molding, 1 to 2 in.....	35 38	1x10.....	23 24
Stained saps.....	32 35	1x8.....	22 23
Bracket plank	35 45	Shaky clear, 1 to 6/4 in.....	32 38
Shelving boards, 12-in. up ..	35 40	" " 2 inch.....	38 40
Dressing boards, narrow... 28		Dressing.....	24 25
1x12 inch shippers.....	31 22	Common.....	25

LATH. Pine	\$3 50	Spruce.....	\$1 40
Sawn Pine ex. XXXX..	\$4 50	Bound hnts, 6x18	\$5 25 5 50
Clear hnts.....	3 50 3 75	Hemlock.....	2 25
Smooth 6 x 18.....	4 50 4 75	Spruce.....	2 20

BUFFALO AND TONAWANDA, N.Y.

UPPERS, 1, 1 1/2, 1 1/2 and 2 in.....	78 00	Shelving, No. 1, 13 in. and up, 1 in.....	40 00
2 1/2 and 3 in.....	85 00	No. 1 Mold st'ps 1 to 2 in.....	48 00
4 in.....	90 00	No. 2 Moulding Strips, 1 to 2 in.....	35 00
Selects 1 in.....	70 00	Barn, No. 1, 12 in.....	32 00
1 to 2 in.....	78 00	6, 8 and 10 in.....	26 00
2 1/2 and 3 in.....	85 00	No. 2, 10 in.....	23 00
4 in.....	55 00	No. 3, 10 in.....	26 00
Fine common, 1 in.....	55 00	No. 3, 12 in.....	20 00
1 1/2 and 1 1/2 in.....	58 00	No. 3, 12 in.....	22 50
2 in.....	73 00	Box, 1x4.....	17 50
3 in.....	78 00	1x6 & up.....	19 00
4 in.....	38 00	1x10.....	19 50
Cut'g up, No. 1, 1 in.....	50 00	1x12.....	21 00
1 1/2 and 1 1/2 in.....	25 00	1x13 and up.....	22 00
No. 2, 1 in.....	36 00	1 1/2 and 1 1/2 & 2 in.....	20 00
No. 3, 1 1/2, and 1 1/2 in.....	27 00	Mill Culls, 1, 1 1/2, 1 1/2 and 2 in.....	17 00
No. 3, 2 " ..	27 00		
Dressing 1 1/2 in.....	40 00		
1 1/2 x 10 and 12.....	40 00		
1 1/2 in.....	36 00		

The following quotations on hardwoods represent the johner's buying price at Buffalo and Tonawanda:

1st & 2nd, 1 inch, 33 00 35 00	2 1/2 to 4 in.....	43 00 45 00	
1 1/2 to 2 in.....	39 00 41 00	Strips.....	22 00 24 00
		Com. and culls.....	16 00 19 00
		BLACK AND BROWN ASH. 1st & 2nd, 6 inch up, 33 00 35 00	Com. & good culls... 15 00 17 00
		BIRCH. 1st & 2nd, white, 6' & np, 24 00 26 00	Com. & good culls..... 13 00 14 00
		up, red.....	36 00 38 00
		ELM. 1st & 2nd, rock, 6in & np 26 00 28 00	1st & 2nd, soft, 6in & np, 24 00 25 00
		Common and culls ..	15 00 17 00
		MAPLE. 1st & 2nd hard.....	21 00 23 00
		Common and culls ..	13 00 14 00
		1st & 2nd, soft.....	19 00 21 00
		Common and culls.....	11 00 12 00

BOSTON, MASS.

White Pine Uppers, 1 to 2 inch	\$32 00 to \$35 00
Selects, 1 to 2 inch.....	68 00 73 00

WESTERN CANADA

Western Offices of The Canada Lumberman,
720-721 Union Bank Building, WINNIPEG, MAN.; 536 Hastings Street, VANCOUVER, B. C.

A MODERN SAW-MILL.

A DESCRIPTION OF THE OTIS STAPLES LUMBER COMPANY AND THEIR PLANT AT BAYARD, B.C.

If anybody believes that lumbering is on the wane, or if he thinks the day for new saw-mills is over, a visit to the fine new plant of Otis Staples, which has just been completed at Bayard, B.C., would dispel any such delusion.

who after winning from the forests of Minnesota a life's competence, has shown his opinion of the future B.C. lumber trade by placing his fortune on this side of the line.

THE MAN.

Who is the man who, single-handed, has done all this? Let us look at his individuality

las, York county, New Brunswick, in the year 1847, and therefore is a Canadian and Britisher by birth. He left Canada in 1869 for Minnesota, going to Stillwater, which is still the home of his family. He operated as a logger around Stillwater, Minn., on the St. Croix river, for years, was successful, and



OTIS STAPLES, BAYARD, B. C.—SAW MILL AND POND.



OTIS STAPLES, BAYARD, B. C.—INTERIOR VIEW OF SAW-MILL.

The plant is located eight miles from Cranbrook on what is known as the North Star branch of the Crow's Nest Pass Railway, or "the Crow", as it is locally termed. At this point the railway crosses the St. Mary's River. At this junction of rail and river the keen Minnesota lumberman, Otis Staples, has erected this new up-to-date plant, and the railway station and post-office established in con-

a moment. A man of medium height apparently about 48 years of age, but in reality 58, of medium weight, iron-grey hair, quick and energetic in action, a kindly look on his face, which displays the keen eagerness of the man within. A man who can extend the friendly hand to the humblest lumberjack and has a good word for all, especially his competitors. Such is the man—Otis Staples.

prospered, his interests finally being taken over by the Johnson-Wentworth Lumber Company. Mr. Staples has been twice married, and has four children living by his first wife. His eldest son, Bayard Staples (a fine type of the bright young American), is a graduate of the Michigan Military Academy, and twenty-four years of age.

Mr. Staples is a director of the First Na-



OTIS STAPLES, BAYARD, B. C.—GENERAL VIEW OF MILLS AND YARD.



OTIS STAPLES, BAYARD, B. C.—PLANING MILL.

sequence thereof have been aptly called "Bayard," after Mr. Staples' eldest son. Here, surrounded by nature's wonders, between the Rocky and Selkirk Mountains, has sprung up a modern saw-milling establishment equipped with the latest machinery and engineered by pluck and brains. Great credit must be given to the man

To one's first glance Mr. Staples looks as he is termed, thoroughly American. Around Cranbrook and the mining towns of Marysville and Kimberly he is called "the rich Yankee." Let us see how "Yankees" are made:—

Otis Staples was born in the parish of Doug-

tional Bank of Stillwater, a director of the Northwest Thresher Company, as well as holding other positions of great importance.

THE LIMITS.

Forty-three square miles is the extent of the tract of British Columbia timber that Mr. Staples now owns. The amount of merchant-

able timber in sight has been conservatively estimated at 300,000,000 feet. Most of this is Western pine and larch, with a little high grade spruce.

THE PLANT.

The buildings have all been placed in ideal positions, carefully laid out, far enough away to give plenty of room, yet convenient to each other. The plant consists of the saw-mill, engine and boiler house, planing mill, lath mill, machine shops, offices, stores, men's quarters, dining hall, sheds and stables.

In the saw-mill are installed a 500 horse power engine, with a McDonough Mfg. Company high speed piston valve engine, three boilers 72 in. by 18 ft., with Dutch ovens, one double cutting band mill with McDonough set works, shot gun feed, steam nigger, and steam guide and McDonough "Eau Claire" edger with battery connection. The saw-mill is a model of neatness and the machinery keyed up to a high rate of speed. There is also a very fine up-to-date lath mill.

In the planing mill there is an 80 horse power engine, one boiler 60 in. by 16 ft., four machines, one combination surfacer and sizer, two matchers, and one siding machine, also rip and cut



OTIS STAPLES, BAYARD, B.C.—ALLEY NUMBER FOUR.

off saws, all of the very latest improved patterns.

The excellent electric light plant is provided for by a 60 h. p. Russell automatic engine, a 400 light dynamo, and about three miles of wire. The mill, planer, yard and all buildings are lighted by electricity.

The water plant for fire protection has a Blake duplex 1000 gallon-a-minute pump, and about a mile of piping throughout yard and mill. The mains in yard are 6 inch (hydrant branches 4 inches), and have 25 connections for 2½ inch hose.

Into this plant run two spurs from the C. P. R. tracks; three thousand feet of these spurs is available for loading, and four thousand feet for switching. A logging road is now being built into the timber. All logs are brought in by their own train, using a Shay locomotive and up-to-date logging cars. The logs are unloaded into an artificial pond, the same being supplied with water by canal from St. Mary's River.

Connecting the saw mill and planing mill and running through the yards is a splendid system of tramways, with seventy lorries or

trucks, all fitted with ball-bearings of the latest type.

A fire station, hose reels and fifteen hydrants furnish fire protection for the plant. Over each hydrant is also placed a hose stand to which is attached ready for instant action several lengths of hose.

Although Mr. Staples bought out the Marysville Lumber Company's plant at Marysville he



OTIS STAPLES, BAYARD, B. C.—LOADING A CAR.

did not utilize the machinery that he got. He bought the mill simply to get the timber owned by that company, then he wrecked the mill and sold the machinery. He has spared no expense in the effort to make the new mill at Bayard, as he wants it to be, one of the best in existence.

With excellent equipment goes an excellent staff, and Mr. Otis Staples, the owner and manager, is to be congratulated on surrounding himself with a staff of young men who are full of energy and progressiveness. The following is the staff:—F. D. Becker, sales manager; D. R. Yates, office manager; J. Harvey Staples, superintendent of timber and logging; F. P. Davis, yard foreman; Glen Clark, mill foreman; Chas. Fisher, chief engineer; J. Swan Anderson, superintendent of planing mill.

THE TIMBER DISTRICTS OF WESTERN CANADA.

The timber districts of Western Canada extend, roughly speaking, from the foothills of the Rocky Mountains north of the 52nd parallel as far east as the second meridian, then taking a straight line south-east, from



OTIS STAPLES, BAYARD, B. C.—LOGGING TRAIN AND SKIDWAY.

the junction of the 52nd parallel and the 2nd meridian to the principal meridian just west of Winnipeg. The timber is chiefly contained in the district north-east of that line, running up as far north as Lake Manitoba. A large quantity of timber is also found around Banff and the Crow's Nest Pass in South-Western Alberta; some is found also in Alberta north of Red Deer, mostly around Edmonton.

Around Prince Albert, in Saskatchewan, a

considerable quantity of jack pine and white spruce is found, the former being used largely for railroad ties.

The greatest timber belt of the middle West is in the Riding Mountain district in Manitoba. All this district is heavily timbered with spruce, tamarac and jack pine. The logs cut there are mostly floated down the Shell river into the Assiniboine river and on to Brandon, where they are sawn.

Around the district of Lake Manitoba and Lake Winnipeg there is a large amount of spruce suitable for pulp. In the Turtle Mountain district in Southern Manitoba, and the Moose Mountain district in Southern Assiniboia, are to be found large areas of native poplar. This, however, has been set aside by the Government as forest reserve, to supply the future needs of the neighborhood in the way of fuel, etc. A little cutting has been done in the Turtle Mountains by parties with portable mills, but not to amount to anything.

All these districts, including the British Columbia railway belt, are under the protection



MR. OTIS STAPLES.

of the Forestry Branch of the Department of Interior, and are patrolled during the dry seasons by fire rangers in the employ of the Forestry Branch, whose duty it is to guard against forest fires in these areas. This is done by constant watching and warning the settlers against letting fires run, and in case of a fire the rangers have power to call on the settlers to help fight it. All timber lands still in the possession of the Dominion Government are under the control of the Forestry Branch in that way.

This system has been in operation for about five years, and with the exception of a fire in the Crows Nest Pass district last season, there has been no serious fire in any of these districts.

TREE PLANTING.

The Forestry Branch of the Department of Interior is also doing a good work in the encouragement of tree planting amongst the settlers of prairie districts. The settlers are encouraged to plant trees on their farms for shelter beds and for raising as far as possible the supply of fuel and fencing material. This is done by the free distribution of such varieties of trees as are known to be hardy. This work is still further augmented by the

sending out of bulletins and providing speakers at institute meetings.

If a settler wishes to get trees he applies to the office at Ottawa before the first of March and during that summer the department sends out an inspector to visit the place. The duty of the inspector is to report as to whether the ground is suitably prepared and what varieties of tree he thinks are best suited to the soil and the local conditions. At the same time he gives the settler all the information he can in regard to planting, laying out shelter beds, etc. From this report a rough plan is made at Ottawa, showing the manner of planting, the distance apart each tree should be, and any further information thought necessary. A copy of this plan is sent to the settler for his guidance in planting. The number of trees sent to a man varies all the way from one thousand to six and eight thousand, according to his needs and desires.

This distribution of trees was started in 1901, and since that time the number of trees sent out, including this spring's shipments, amount to about 500,000. The varieties principally sent out are Manitoba maple, green ash, Dakota cottonwood, American elm, several different kinds of willow and some Russian poplar. All trees sent out are kept track of and so far the reports have been extremely favorable and encouraging, not more than 15 or 20 per cent. of the trees planted having died.

The trees have all been grown at Brandon and Indian Head. Within the past year, however, another and much larger nursery has been started at Indian Head and all trees in future will be raised there. It is estimated

looking after the work, giving out the trees, etc.

ACTIVITY AT EBURNE.

During the past few months there has been "things doing" at the little town of Eburne, B. C., on the British Columbia Electric Railway Company's new electric line to Steveston. Of course an important circumstance for the town was the electrifying of the railway, but another source of activity there is the saw mill plant of the Manitoba Lumber Company. This little concern, of which Mr. M. R. Wells is the manager, is doing a rushing business in their special line, which is more particularly the turning of the biggest cedar logs they can find into clear cedar lumber. During the past year they have been making extensive changes and improvements to their plant in order to cope with the demand. Amongst other things they have practically doubled the capacity of their saw mill, bringing the daily average up to 17,000 feet, and have added a Letson & Burpee "Simplex" shingle machine. They have erected a new planing mill, 45x90 feet, and added to that department a 12-inch four-sided McGregor-Gourlay sticker. The old dry kiln has been torn down and a new and larger one erected about 130 feet away from the site of the saw mill. The boiler-house has been moved 20 feet away from the mill and a 14x20 Atlas engine added, together with a 60" by 16 foot boiler made by N. Thompson & Company.

The British Columbia Electric Railway have also taken a hand in the matter and are putting a spur line right into the mill yard. They will henceforth haul the cars to and from Vancouver by electric motors, from where they are

ship their product. The British Columbia Electric Railway will haul all the loaded freight cars to the C. P. R. yards and the empty cars back to the mills. This will be a great convenience to the lumbermen, as they can usually obtain the use of the electric locomotives to move a car in much quicker time than they can obtain an engine.

THE CAPITAL PLANING MILLS.

One of the most flourishing industries on Vancouver Island is that of Lemon & Gonna-



INTERIOR VIEW CAPITAL PLANING MILLS.

son, known as the Capital Planing Mills. This business was started in 1890 by the present owners, Messrs. J. Lemon, A. Gonnason and B. Gonnason. When they started business the plant consisted only of a small planing mill and sash and door factory. This was gradually enlarged as business increased. Last year they decided to make a more extensive increase by building a saw mill and a little later followed that up by adding a box manufacturing plant. The saw mill machinery was built by the Schaaque Machine Works of New Westminster. The style used is the double circular saw mill with a capacity of 20,000 feet per day of ten hours. The company have divided their affections in the particular make of saw used, those of the California Saw Works and of the A. J. Burton Saw Company being found in operation. In the box factory a very complete plant has been installed. It includes a McGregor & Gourlay planer, Cowan & Company band resaw machine and a California Saw Works Company revolving cut-off saw, also a printing press. The building itself is 30 feet wide by 120 feet long, well lighted and in every way adapted to the needs. They intend making a specialty of fruit and salmon boxes.

NEW OFFICES.

Allis-Chalmers-Bullock, Limited, have made a change in their British Columbia branch. This end of their business has been in charge of the local agency of the Canadian Fairbanks Company. Recently, however, Mr. G. C. Hinton, of the Hinton Electric Company, was appointed sales manager for British Columbia. They have opened up offices on the Seymour street side of the "Old Safe Block," corner of Hastings street, Vancouver. Here a complete stock of the Allis-Chalmers-Bullock products will be kept, including rock drills and rock drill parts and electric and saw mill machinery.

Mr. Hinton, though becoming local manager of Allis-Chalmers-Bullock, still retains an interest in the Hinton Electric Company.



CAPITAL PLANING MILLS, VICTORIA, B. C.

that this nursery will supply from three to four million young trees annually.

This work is all under the direct supervision of Mr. Norman M. Ross, the assistant superintendent of the Forestry Branch. During the winter Mr. Ross is located at Ottawa, but in the early spring he goes to Indian Head and remains there all through the summer

shipped to the lumber company's various customers in the Northwest.

In connection with the electrifying of the Vancouver-Steveston railroad, the British Columbia Electric Railway Company have also electrified the track on the south side of False Creek, which is the means whereby the various lumber companies operating along that shore

THE Wood-Worker and Retailer

HOW TO MAKE SPIRAL MOULDINGS.

A correspondent signing himself "Factory Hand" writes as follows: I have been told that there is a method employed in some woodworking factories by which a rope or spiral moulding can be made on an ordinary sticker by making use of a few simple home-made devices. Will you kindly publish a

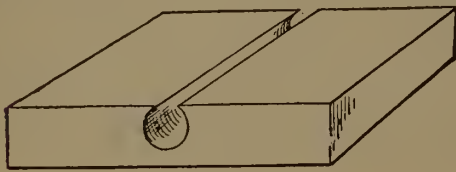

FIG. 1.

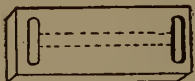

FIG. 2.

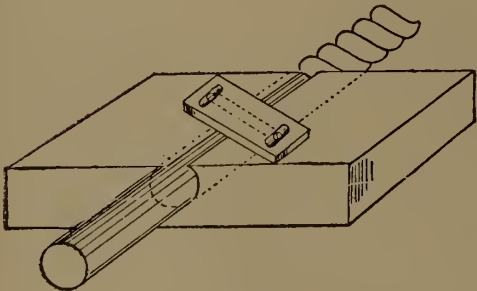

FIG. 3.

description of these devices, or refer me to some work where I can obtain the required information, and oblige?

Ans.—The following description of this device, which was sent by a correspondent to

both made in Battle Creek, Mich. Next make a wooden table on sticker over the top head, with an opening for the knives. Then take a block of wood, say $1\frac{1}{2}$ thick by 6 inches wide, 16 or 18 inches long, and bore a $\frac{7}{8}$ hole to one side and through the block, letting the bit cut out about $\frac{1}{8}$ of an inch, as in Fig. 1. Fasten this block on the table over the knives, so a rod in the block will lay at an angle of about 45 degrees to the head. Then run bed of machine up until knife will cut a full head or beads. The best to experiment on will be the 3 strand when cut with a common stocker knife with three heads $\frac{1}{2}$ inch or thereabouts,

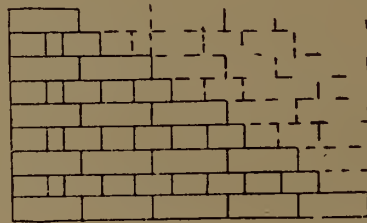

FIG. 4.

with the centre bead dropped back a little. Next, the arrangement for twisting the stock through the block: Take a block of hard wood 4 inches wide, 8 inches long, $\frac{7}{8}$ inch thick. Slot each end about two inches. Take two thin pieces of steel—old jig saw blades will do. Make them sharp on the back and drive them into the block lengthwise in saw kerfs, about $\frac{1}{4}$ inch apart—see Fig. 2. The object of the slots is for adjustment for making the beads intersect. Fig. 3 shows the

son can get along with twister I have described if he doesn't want to make moulding for market, but only for his own use. The tighter you have the twister the more positive the feed, and, as it will turn pretty hard, one can use a block to turn with. Drop out one or two beads and run some; you will be surprised at the result.

PATENT BEVEL SAWING MACHINE.

The illustration represents a new combination sawing machine, which is adapted for all kinds of mitre and bevel sawing, and has been placed on the market by the Connell & Dengler Company, of Rochester, N. Y.

The saw can be adjusted to any angle, from perpendicular to 45 degrees, while in motion and can be raised or lowered to cut any depth into the stuff, or entirely through it. The hand wheel shown on the side of the machine gives the saw the required angle, governed by an index, while the hand wheel in front of the machine regulates its height.

The saw being pivoted in the plane of the table, requires no more space when set at an angle than is necessary for it to run in, and whatever may be the position of the saw, the table always remains stationary.

The cut shows ways attached to the frame of the machine, and a running table, which is intended for both ripping and cross-cutting. By this arrangement long or short stuff can be sawed at any desired angle, the saw being set for one bevel, and the gauge for the other. In this way every desirable angle can be cut, or, if necessary, the running table can be made stationary, and the machine used as an ordinary saw bench.

The saw frame being hung in trunions supported on opposite sides of the saw, makes it reliably true, as the center of the trunions are in the face of the table. This feature is entirely new in saw benches and makes

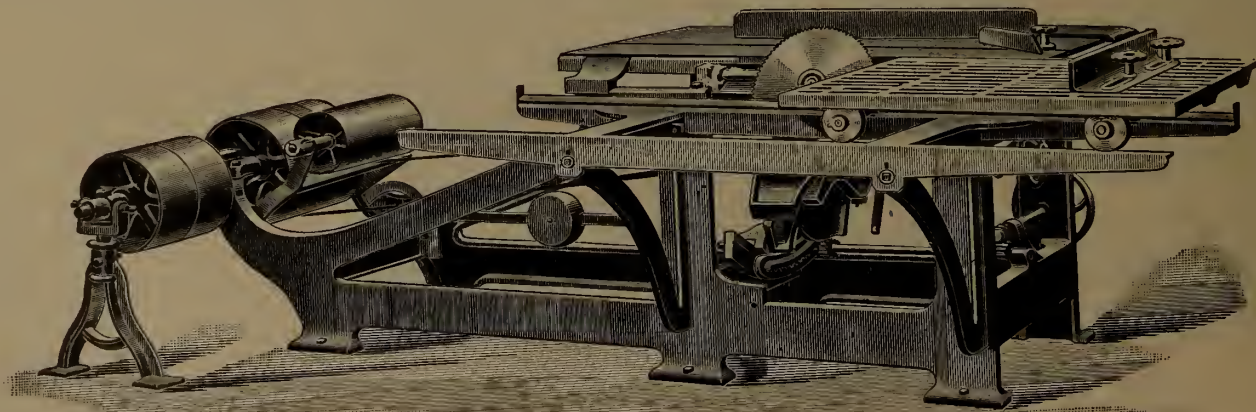

PATENT BEVEL SAWING MACHINE—MANUFACTURED BY CONNELL & DENGLER MACHINE CO., ROCHESTER, N. Y.

The Woodworker some years ago, seems to cover the ground asked for by our correspondent. First, make stock to be worked round say $\frac{7}{8}$. I have a chuck for this purpose that works from $\frac{1}{4}$ to $\frac{3}{4}$ inch and one that cuts from $\frac{7}{8}$ to $1\frac{3}{4}$, a nice lathe tool—

twister in position. The stock is twisted through by hand. In case the knives do not cut out feed marks, move the twister until they do. There is a machine made in Battle Creek for twisting the stock either by hand or power which costs about \$3 or \$4, but a per-

it possible and easy to saw straight or beveling on a stationary table.

The planing mill of the late O. Manuel at Burtford, Ont., has been sold by the directors to S. M. Southwick, who will continue to operate the mill and also have a lumber yard in connection.

AMERICAN IMPROVED NO. 2½ SASH STICKING MACHINE.

The accompanying illustration represents a late machine made from new patterns with improved attachment for boring and grooving sash stiles at one operation as they pass through the machine. The stile is placed on the grooving table and pushed forward against a counterbalanced stop, making the wide groove. This stop then drops below the table and the stile is pushed forward against the second stop, then by pressing the foot on the treadle the bit bores the stile at an angle, so that the knot in the cord will draw toward the bottom of the hole when the weight is attached. The stile is then placed against the second gauge and the narrow groove is completed to the hole. The stile is then placed under the feed rolls and run through the machine.

The frame is cast in one piece, making the machine very solid and substantial. The feed consists of two top driven rolls 2 inches in diameter, and one 4 inch idle roller in the bed.

The under cutter head stock is so constructed that heads are interchangeable without removing the arbor. The belt for the under cutter head has the same ten-

into the sill, the latter to be left projecting ¼ in. The head and pulley stiles should not be less than 1½ in. thick; the pulley stile to be checked for the guard bead; the pockets to be cut in centre of stiles and pocket pieces, v-pointed or beaded, to prevent damage to paint when removing.

2. In sash frames all linings should be grooved, and tongues worked on head-and-pulley stiles to fit same. The head linings should be well blocked.

3. Bottom meeting rails of sashes should be housed into stiles and also dovetailed.

4. In spacing for sashes it should be remembered that stuff wrought both sides finishes ⅓ in. less than reputed sizes, e.g. 2 in. is 1⅞ in. bare when finished.

5. The ventilating piece should be bevelled ¼ in. and tongued into the sill, housed into the pulley stiles, and have the guard bead

forming each ring to be of different lengths, the butt joints tongued, and the pieces screwed together. The head should be cut back a few inches above the springing to form a stop for the sashes to prevent them from jamming.

11. "Circle on circle" sash frames should always be made with the pulley stiles parallel, otherwise the top sash must be inserted from the outside, rendering it difficult to make the frame watertight, and dangerous to renew the cords.

12. For quick sweep on plan, these frames require purpose made axle pulleys, the face plates to be set at an angle with the pulley boxes, and in pairs.

13. Bay Window Frames—The sills of these should be mitred at the point, ploughed and tongued, and fastened with a handrail bolt. These should be Brunswick blacked before insertion to prevent corrosion. The heads should be solid and halved together.

14. Venetian Frames with side lights fixed can have solid mullions about 2 in. thick, the cords from the middle pair of sashes being

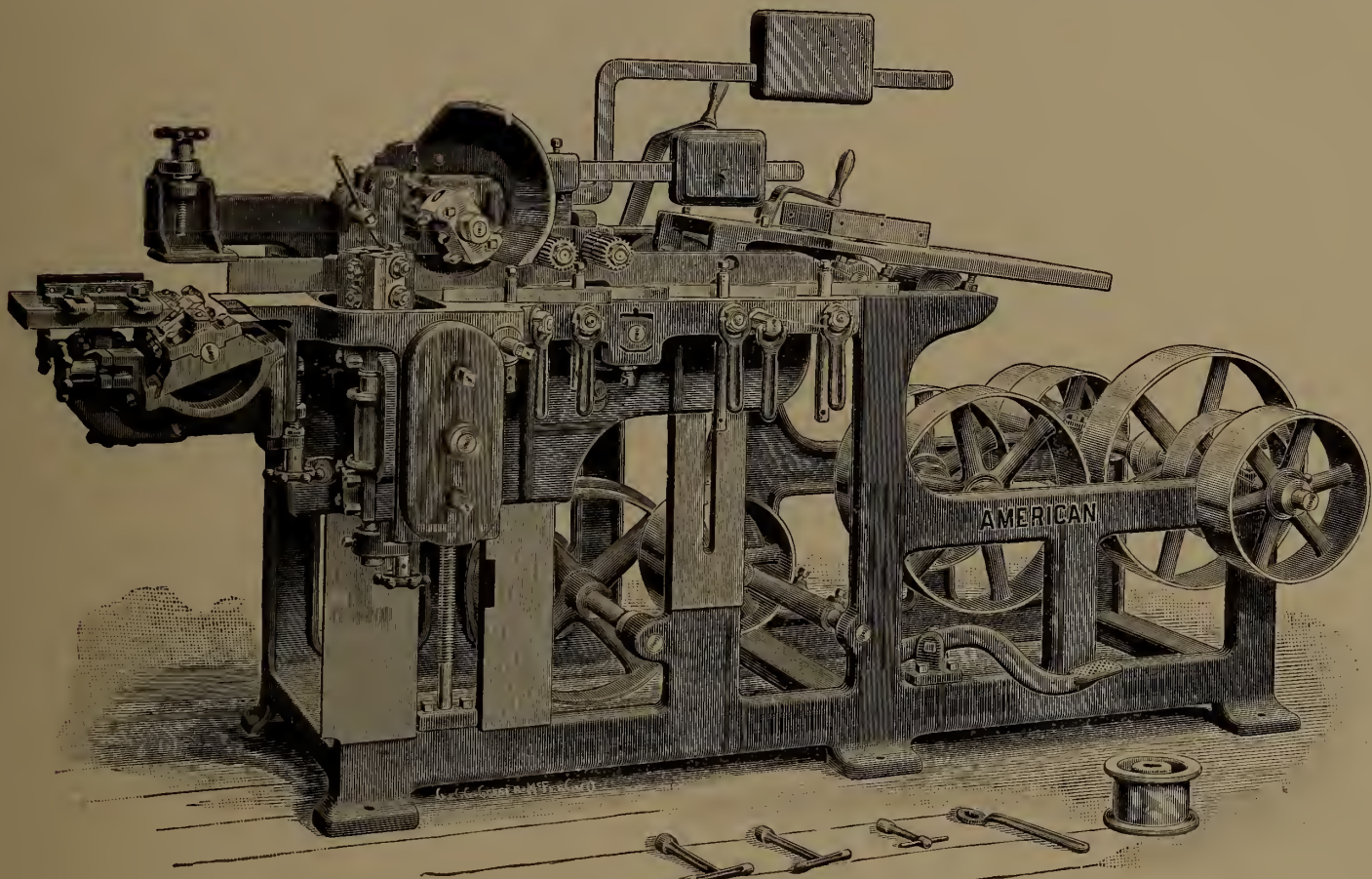

AMERICAN IMPROVED NO. 2½ SASH STICKING MACHINE.

sion and is tight at all points. The bed drops 16 inches.

The machine is made as a one, two and three sided sticker. Complete machine has top, bottom and outside heads.

The manufacturers of this machine are the American Wood Working Machinery Company, 136 Liberty street, New York.

ABOUT WINDOW FRAMES.

A builder writes: "I have a number of pine window-frames to make for a brick house, frames specified to be first class and to have oak sills, boxed venetian blinds, several to be made to fit a circular tower and to have circular heads. I am equal to the construction part; but lack knowledge as to what is meant by first-class frames. Can you give me any information on the subject?"

Ans.:—We submit the following which we think covers all the ground contained in your queries.

1. For first-class pine sash frames the linings should be mortised and tenoned at the heads, and the outside linings stump-tenoned

stuck on the solid. All beads should be mitre rebated, and fixed with cups and screws. It improves the frame to return the parting bead across the head.

6. The oak sill should project at least ⅓ in. beyond the face of outside linings because if finished flush it will shrink below the face in a short time, and expose the edges of linings to decay.

7. Keep the water bar near the outside edge of the sill. Groove the back edges of the inside linings, and insert the back lining in the groove.

8. Wide or heavy sashes should have a pair of 3 in. brass sunk flush lifts let in the bottom rails, and a pair of brass handles fastened under the top meeting rail near the stiles if there are no vertical bars.

9. Very high sashes should have cords with handles attached fixed in the centre, with a long arm and hook provided for lifting. A recess should be provided in back of architrave to receive this.

10. Circular headed frames should be cut out of the solid, in two thicknesses, the pieces

taken over pulleys in the top ends of the mullions, and through the top rails of sidelights into the outside casings. In consequence of the greater width of these frames, and the possible weight they may have to carry, it is usual to make the heads solid—about 3 in. thick. The mullions should be tenoned through the head and sill, and the outside linings stopped at the sill and tongued in, so that the sill may be continuous.

15. Boxed Venetians—When it is desired to hang all the lights, the mullions must be boxed and divided by a parting lining. When this form would be unsuitable through the width of the mullion, a mullion with a single boxing can be used, by hanging two sashes to one weight, having a pulley fixed at one end. To obtain the necessary weight in small compass, it should be of lead and in square section.

16. Single lights are useful for thin walls. One-half of the frame is glazed, and the other half contains a sliding casement, working on metal bars.

17. All sliding sashes should have metal shoes let into their edges.

18. The parting slips of sash frames are often of zinc inserted in a saw kerf in the head of the frame turned down and nailed on top.

ELECTRIC LOADING OF LUMBER.

Many of the saw mills of the Pacific Coast are installing electric power lumber loading derricks, which are proving a great saving in both time and men. Two of the largest have been installed by the Hinton Electric Company in the Pacific Coast Lumber Company's mill at Vancouver and the Brunette saw mill at New Westminster. These derricks are operated by electric motors, the current being supplied from dynamos in the mill plant. The two derricks referred to have each replaced on an average 17 men and handle with ease timbers weighing eight tons.

THE BRITISH COLUMBIA BOX COMPANY.

The British Columbia Box Company, of Vancouver, who bought out and succeeded Harvie & Sharpe, box manufacturers, have recently been reorganized into a joint stock company. The president is S. J. Smith, secretary C. P. Moss, and manager Thos. Harvie. The new company have installed an entirely new plant, replacing all the old machinery by modern apparatus. A new double surfacer, planer and matcher, a 6-inch band re-saw, a tongue and groove machine, together with several cross-cut and ripping machines, were purchased from the McGregor Gourlay Company, of Galt, Ont. The California Saw Company supplied the filing room outfit.

The present capacity of the plant is about 100,000 feet of lumber made into boxes each month. The company manufacture all kinds of fruit, fish and vegetable boxes for the export trade, also a large number of biscuit and sugar boxes for the local industries.

THE LATE W. H. PRATT.

The death of William Henry Pratt, which occurred at his family residence, 166 St. George street, Toronto, on July 13th, removed a gentleman who for over twenty years had been prominently identified with the lumber business.

He was born in Milton Township, Saratoga



THE LATE W. H. PRATT.

County, N.Y., August 17th, 1829. He was educated at Hamilton College, N.Y. State, and and went to Illinois in 1856, where he established and conducted a private school from 1856 to 1861. From 1861 to 1865 he was a member of the Illinois State Administration under Governor Dubois. In 1865 he moved to St. Louis, where he was in business until 1870. In 1870 he came to Canada and built a hotel at

head of Lake Rosseau, Muskoka, which was practically the pioneer of the summer hotels on the Muskoka Lakes. This hotel was destroyed by fire in the fall of 1883, and in February, 1884, he established the Conger Lumber Company at Parry Sound, in conjunction with A. N. Spratt, of Alpena, Mich. In 1888 Mr. Spratt's interest was purchased by Mr. Pratt, who has been the sole owner of the business ever since.

The mills and limits owned by the Conger Lumber Company were originally purchased from the estate of the late J. C. Miller, of Parry Sound. The original mills were destroyed by fire in April, 1901, but were immediately re-built, the new mill being one of the most modern on the Georgian Bay.

The deceased is survived by his widow, his son, Mr. W. L. Pratt, and his daughter, Mrs. W. B. Maclean, wife of the secretary of the company.

The death is announced of Mr. Luc Bergerson, saw and grist mill owner, St. Clothilde, Arthabaska county, Que.

THE LUMBER ANTI-STAIN COMPANY

Head Office, WILMINGTON, DELAWARE

To Lumbermen:

We hereby give notice that two infringement suits have been filed in the Circuit Court of the United States for the Western District of Michigan, Northern Division, for the infringement of our patent No. 746,678, dated December 15, 1903, relating to the treatment of lumber for the prevention of sap staining, and we warn others that infringements of our rights will be vigorously prosecuted. Rights to use this valuable process may only be obtained by applying to

Robert H. Munson, President,

Lumber Anti-Stain Company,

Sault Ste. Marie, Mich.

Our Canadian patent is number 91936.

LUMBERMEN'S LOG STAMPS
STEEL & RUBBER STAMPS, BRASS STENCILS, ETC.
THE SUPERIOR MFG. CO.
COR. BAY & ADELAIDE STS., TORONTO, CAN.
Write for Catalogue.

JNO. S. FIELDING, C. E.

WATER POWERS AND DAMS

Room 2, 15 Toronto Street - TORONTO

The Cook & Bros.
Lumber Co.

Of Ontario, Limited
MILLS at SPRAGUE, Algoma Dist., Ont.
on "Soo" Branch C.P.R.

OFFICES (Manning Arcade, Toronto
Coristine Building, Montreal
And at Mills at Sprague.

MANUFACTURERS OF

**White and Red Pine
Lumber and Lath**

Water Shipments

WIRE PULP MATS

Perforated Copper, Brass and Steel
Wire Rope: all kinds
Wire Guards for Mill Windows
Refuse Burner Cloth, etc.

The B. GREENING WIRE CO., Limited
HAMILTON, ONT. MONTREAL, QUE.

ATKINS ALWAYS AHEAD!



QUALITY IS THE THING!

Substance, not the Shadow of Quality

Characterizes the Silver Steel Saws bearing the celebrated "AAA" trade mark. Superiority of material, our patent process of tempering, perfection of grinding and experience and skill in workmanship are the leading features in the make-up of an Atkins Saw. These qualities insure perfect running saws and satisfaction to the user. The highest intrinsic value ever offered and the most efficient service possible to obtain are secured when you purchase an Atkins Saw. A trial is convincing proof. Think it over and let's have your order now.

Our Machine Knives, too, are made with a view of retaining you as a permanent, satisfied patron. What more can we say?

Mill Supplies of every description. Write for our 1905 Saw and Saw Tool Catalogue and Sawyer's Hand Book. It's free.

E. C. ATKINS & CO., Inc.,

Leading Manufacturers of Circular, Band, Cross-Cut, Hand and Wood Saws, Etc.

Factories and Home Office,
Indianapolis, Ind.

Canadian Branch,
56 King St East, Toronto, Ont.

FOR THE CAMP

We have a very suitable lot of goods for camp supplies. We make this kind of trade a specialty. You who are not getting suited just as well as you would like, try us for your next order, and give us a chance to demonstrate our ability to give you satisfaction in this very important department of your business.

H. P. ECKARDT & CO.

Wholesale Grocers

TORONTO

WILL SELL THE TIMBER.

In view of recent forest fires along the line of the Temiskaming & Northern Ontario Railway, the Ontario Government have decided to dispose of the timber for a quarter of a mile on each side of the track. The railway runs through about forty miles of timber lands. The timber is principally pine.

LUMBER GRADES.

A subject of increasing importance to every lumber producer and consumer is that of grades. That these grades should be uniform where practical is well recognized and many efforts to arrive at some general rules have been made. In view of these movements to standardize grades, the Forest Service of the United States has undertaken to bring together the specifications of the various lumber and manufacturers associations and to put them in such a form that they may be compared.

The object of the study is not to devise a system of standard grades but to make, simply, such a compilation of the grades now in use as will be of service to lumber producers and consumers, though it is hoped that a great deal of information may be accumulated that will be of value in eventually preparing the way for a standard system.

It is planned to get the views of those concerned partly by interviews and largely by correspondence. A representative of the Forest Service will endeavor to visit the secretaries and members of grading bureaus of various associations and learn their views in regard to the practical workings of the various rules. A large number of mill men and manufacturers will be reached by correspondence and their views sought. It is especially desired to find the important points of difference in grades from the view points of both producer and consumer of lumber, and also to ascertain the chief difficulties in the way of devising and executing a system of standard grades.

The assistance of manufacturers and consumers of lumber is earnestly desired in this work. Suggestions concerning it will be gladly received by the Office of Forest Products, Forest Service, Washington, D. C.

The Listowel Furniture Company, Listowel, Ont., have recently installed an automatic feed pump and receiver for returning the drips from the kilns to the boilers, the apparatus being supplied by the Smart-Turner Machine Company, of Hamilton.

A \$300 LICENSE.

ST. LOUIS, July 10th, 1905.

THE CANADA LUMBERMAN, Toronto, Canada.

Gentlemen: Messrs. R. G. Dun & Company printed on one of their daily report sheets recently, that the Parliament in the Province of Quebec have passed an act as follows:

"It is enacted that any non-resident traveler or agent soliciting orders for goods, other than intoxicating liquors, for firms or corporations having no place of business in Canada, shall require a license to cost \$300, renewable the first day of May each year.

"Any person contravening this law is liable to a penalty of not more than \$1,000, and not less than \$500, for each infraction thereof, and no party shall lend his license to another under the penalty of \$300."

The above is undoubtedly of considerable interest to merchants in the United States, also quite a few lumbermen, and if the above act was printed in the trade journals or daily press, it did not come under our observation, and it appears to us to be a very unusual act or law that would restrain all classes of business except the liquor business. Is it possible that the liquor manufactured in Quebec is of such poor quality and the American liquor of such high quality, that they prefer and want American liquors? On the other hand, can it be possible that they are unable to manufacture a sufficient quantity in Quebec to satisfy their thirst, or is it the object to encourage competition, that they may secure it at the least possible cost.

In this country we would call this class legislation, for the reason that it is for the benefit of one class of people, the consumers of Alcoholic hardware, as there are many people in Quebec who do not use commodities of this kind, and would therefore receive no benefit thereby. In addition this act would encourage deception and fraud. The dealer in underwear would be tempted to bill his stock as "Wet Goods," while we would be tempted to use a Cypher Code about as follows:

Mr. John Smith,

Montreal, Canada.

Dear Sir:

We have entered your order given our Mr. J. L. Scheve as follows:

10 M. White and McKay Special \$70. (1st and 2nd 1-in. $\frac{1}{4}$ White Oak.)

5 M. Old Mull Blend \$75. (1st and 2nd 1 $\frac{1}{4}$ -in. $\frac{1}{4}$ White Oak.)

10 M. Andrew Usher G. O. H. \$75. (1st and 2nd 1 $\frac{1}{2}$ -in. $\frac{1}{4}$ White Oak.)

5 M. Andrew Usher Reserve \$75. (1st and 2nd 2-in. $\frac{1}{4}$ White Oak.)

On the face of the above, some of the trade might think we were giving them a larger "load" than they could take care of. While our lumber will make a man smile, it would not be the liquid smile, but the smile that would make that Quaker Oats man take off his hat, take a drink and then take "to the woods."

Respectfully,

THE BONSACK LUMBER COMPANY.

John Briggs & Son, Brockville, have recently ordered from the Smart-Turner Machine Company, Limited, Hamilton, an automatic feed pump and receiver for handling the drips from the dry kilns.

PERSONAL.

Mr. James Stack, a well known lumberman of Eganville, Ont., died last month in the Ottawa hospital.

Mr. William F. Hubbard, an assistant in the forest service of the Department of Agriculture at Washington, D. C., and formerly of Toronto, was drowned in the Potomac river near Great Falls, Md., on July 17th.

Mr. W. E. Birnie, representing the Yale Columbia Lumber Company, Nakusp, B. C., and the Kootenay River Lumber Company, Nelson, B. C., was a recent caller at our Winnipeg office, and reports lumber sales very good.

Miss Lilian B. Staples, daughter of Mr. Otis Staples, the millionaire lumberman of Minnesota, who has established a large mill at Bayard, near Cranbrook, B. C., was recently married to Dr. Frank W. Green, of Greenwood, B. C.

Mr. Charles M. Thompson, a prominent American lumberman, who came to Toronto from Chicago a few months ago, died very suddenly last month. He had intended going to the Parry Sound district to inspect some timber limits.

Mr. J. M. Smith, manager of Cushing Bros. & Company's factory at Regina, N. W. T., has been receiving the congratulations of his friends upon his recent marriage to Miss Ross, formerly of the Indian Head Industrial School staff.

Mr. R. Wells, manager of the Manitoba Lumber Company at Eburne, B. C., recently sustained a loss in the death of his youngest son. The little fellow, who was five years of age, had been ill some time ago with typhoid fever but was almost recovered, when he was suddenly attacked with brain fever, resulting in his death.

Mr. Joshua Knight, of St. John, N. B., died on July 1st after an illness which, though threatening for several months, reached a crisis only during the few preceding days. Mr. Knight has for years been a prominent figure in New Brunswick lumbering circles, having been a member of the firm of J. & L. B. Knight, whose mill and lands were located at Musquash, St. John Co. Mr. Knight retired from active business about two years ago, after a long and successful career. A man widely respected for his integrity and industry, his many friends look upon his loss with the keenest regret.

PUBLICATIONS.

H. W. Petrie, Toronto, is issuing monthly stock lists of iron and woodworking machinery, new and second-hand engines, boilers and steam appliances and other power equipment. He is the Canadian representative of the Kenworthy Engineering & Construction Company, Waterbury, Conn.

A recent catalogue from R. Hoe & Company, Rand street, New York, points out very clearly the many advantages claimed for their chisel tooth saws. It is an entirely new issue, with new prices and new discounts, and contains valuable information for millmen. A copy will be gladly sent, without charge, to any one making application. We learn that orders for chisel-tooth saws are increasing all the time, and that there are now over 50,000 in successful operation.

THE NEWS

ONTARIO.

—E. D. Jacob, planing mill, etc., Sebringville, Ont., has offered to compromise with his creditors at 30 cents on the dollar.

—D. R. VanAllen, who has a saw mill at Chatham, Ont., has secured a contract for 100,000 oak ties for the Great Western Railway.

—J. H. Chambers, of Rydal Bank, Ont., is interested in the Algoma Furniture Company, recently organized at Bruce Mines, Ont.

—Frank Hunter was fatally injured in Knight Bros.' saw mill at Burk's Falls, Ont., by being struck by a slab thrown backwards from the saw.

—Emery & Thompson contemplate enlarging their saw mill plant at Fort Frances, Ont. They have just completed their sash and door factory.

—The Hope Lumber Company, a corporation incorporated under the laws of the State of Michigan, has been authorized to do business in Ontario. Their attorney is Charles McCrea, of Sudbury, Ont.

—It is stated that E. W. Baekus and his associates will shortly incorporate the International Lumber Company, to build and operate a saw mill in the neighborhood of Fort Frances, Ont., to have an annual capacity of 25,000,000 feet.

—The Kearney Lumber & Manufacturing Company, Keaney, Ont., have just completed an addition to their factory. They are now in a position to manufacture chair parts of all kinds for export and are making a range of medium and cheap wood seats for the Canadian trade.

—The Standard Chemical Company of Longford, Ont., are building a new chemical plant at South River, Ont., from plans prepared by E. D. Pitt, architect, of Niagara Falls, Ont. The plant will have a capacity of about 36 cords per day. The refuse from the South River Lumber Company's mills will be used. The Standard Chemical Company have extensive hardwood limits near South River.

—The Toronto Lumber Company have started in business at 432 Logan avenue, Toronto, where they will make a specialty of catering to the demands of builders and contractors. They are conducting a wholesale and retail yard. The firm consists of Mr. H. Hancock, who was for many years with the Ontario Lumber Company, and Mr. W. N. McEachren, who has had over twenty years experience in the lumber business.

—Hon. Nelson Monteith, Minister of Agriculture for Ontario, has stated that efforts to secure the necessary land in Toronto district as a nursery for trees for reforestry purposes had been unsuccessful and the scheme had fallen through for the present. In the meantime, he said, the work would be carried on in experimental stages at Guelph Agricultural College.

He hoped to be able to establish a nursery in Toronto district in the near future, as the climate and soil were better adapted to the purpose than any place in the province.

THE EASTERN PROVINCES.

—T. B. Babbitt & Sons, of Gibson, N.B., are building a new saw mill at St. Marys, in which modern machinery will be installed.

—The Wire Cased Cheese Box Company of Canada has been registered by H. C. Organ, Edwin J. Carpenter and J. J. Howard, with head office in Montreal.

—Judge Baker and John Kilburn, of Fredericton, and O. P. King, M.P.P., have been appointed a commission to investigate charges against the Restigouche Boom Company.

—The factory of the Miller Tanning Extract Company at Millerton, N. B., was totally destroyed by fire on July 25th, together with about 200 barrels of extract. The exact loss is not known at time of writing.

—Copp, Dixon & Company, whose wood-working factory at Sackville, N.B., was destroyed by fire recently, have not yet decided to rebuild. They have received several offers to remove to other places.

—O. F. Stacy, William G. White and George Gilbert, of Bathurst, N.B., have been incorporated as the O. F. Stacy Company, Limited, to carry on a general lumbering business. The capital stock is \$50,000.

—The case of the Dalhousie Lumber Company versus the Restigouche Woodworking Company has been adjourned until August 15th, and it is understood that negotiations are on foot for effecting a settlement.

—The McLennan Lumber Company, Limited, of Montreal, has been incorporated, to acquire the business carried on by Duncan H. McLennan under the name of Bulmer McLennan & Company. The capital of the new concern is \$100,000.

—It is reported that the American syndicate which recently purchased the lumber property of the William Richards Company of Chatham, N. B., will, in the near future, commence the erection of another mill at Clark's Cove, about a mile above Chatham, and that a pulp and paper mill may also be included in the enterprise.

—R. Macfarlane & Company, Limited, Montreal, have been incorporated with a capital stock of \$100,000, to carry on business as general contractors and builders and as manufacturers of sashes, doors, blinds, mouldings, etc. It is proposed to acquire the business carried on in that city under the name of R. Macfarlane & Company.

—The New Brunswick Government have decided to appoint a fire warden and five fire rangers to accompany the G.T.P. survey from Edmundston to Moncton for the purpose of guarding against starting of forest

fires along the route, and the protecting of valuable timber areas. The appointments will be under the terms of the legislation passed last session. Each warden will be allotted about forty miles of territory, and will be granted the powers of a provincial constable with authority to act and effect arrests. The rangers will be paid by the Dominion government.

—The Rosebank Lumber Company, composed of O. W. Nordin and other Swedish capitalists, have recently completed a saw mill at Douglastown, N.B. It is now proposed to erect a large planing mill to cost approximately \$100,000, to supply planed lumber for the English, Australian and American markets. Mr. Hedalens, of Stockholm, Sweden, recently completed the arrangements with Mr. Nordin, who states that the machinery will be brought from Sweden. It is expected that the erection of the mill will be begun this fall.

—The British Newfoundland Company, which was formed by H. J. Crowe, of Halifax, to acquire and develop the properties of the Newfoundland Pulp & Lumber Company, the New Land Company and the Timber Estates Company, all of Newfoundland, completed the deal last month. The combined properties comprise an area of 1,600,000 acres. The capital stock of the new concern is \$5,000,000. Mr. Crowe went to England a short time ago, and succeeded in enlisting the support of representative newspaper owners and publishers, who with Boston and Montreal capitalists, provided the necessary funds. Mr. Crowe may assume the management of the new company.

MANITOBA AND THE TERRITORIES.

—C. Johnston has opened a lumber yard at Tyndall, Man.

—W. A. Finlay is closing up his lumber yard at Kelloc, Man.

—The dissolution is announced of the Manning & Jefferson Lumber Company, Tuelon, N.W.T.

—The incorporation is announced of the Interior Lumber Company, Limited, Calgary, N.W.T.

—Harbison & Saturley have disposed of their lumber business at Innisfail, N.W.T., to H. J. Saturley.

—J. K. Ross has disposed of his lumber yard at Bradwardine, Man., to the Prairie Lumber Company.

—The death is announced of W. E. Willis, of the firm of Willis Bros., general store and lumber, Spring-side, Man.

—The Medicine Hat Lumber & Manufacturing Company, Limited, Medicine Hat, N.W.T., has been incorporated.

—The Foss Lumber Company, of Winnipeg, have recently been incorporated, and have acquired the business of the Menz Lumber Company. The new con-

TENTS

That are the acme of perfection, in all details of work. BRITISH ROYAL NAVY method of cut, workmanship and finish. MATERIAL used made in SCOTLAND by the Navy Contractors. Samples and prices are mailed on request.

TOBIN TENT & AWNING CO. OF OTTAWA Long 1 istance phone No. 432

CRAIG MINE CRYSTAL CORUNDUM WHEELS

Our Pure Crystal Corundum Saw Gummars have no equal for their Rapid, Cool, Cutting Properties.



Read the following from Bulletin 180 of the United States Geological Survey, which says:
 "Often a distinction is made between emery and corundum, many persons not recognizing emery as a variety of corundum.
 Emery is a mechanical admixture of corundum and magnetite or hematite. It is, of course, the presence of corundum in the emery that gives to it its abrasive qualities and makes it of commercial value, and the abrasive efficiency of emeries varies according to the percentage of corundum they contain."

Emery is imported, mined by Greeks and Turks and contains only about 25% corundum. Our Crystal Corundum is guaranteed to be 98% pure alumina, a Canadian product, mined and manufactured by Canadians for Canadians.

HART CORUNDUM WHEEL COMPANY, Limited, Hamilton, Ont., Can.

cern is capitalized at \$20,000. The directors are J. F. Foss, G. E. Foss, S. S. Easton, H. S. Easton and B. A. Murphy, all of Winnipeg.

—The new planing mill of the Western Manufacturing Company at Regina, N.W.T., has been completed, and started operations last month. Besides doing the ordinary work of a sash and door factory and planing mill, the company are manufacturing a grain separator. It is also their intention to manufacture bar fixtures, show cases and general bank and shop furnishings. E. J. Brookes is president of the company, D. C. B. Graham secretary-treasurer, and W. A. Hamilton general manager. Mr. Hamilton has had a large experience in the lumber business in the Ottawa Valley and elsewhere.

BRITISH COLUMBIA.

—The saw mill of A. G. McKay at Ymir, B.C., has been purchased by Bruce Weite.

—The saw mill of Grant & Mounce at Comox, B.C., has been acquired by R. Carter.

—E. Ruffner & Company, who operate a saw mill at Discovery, B.C., recently suffered a slight loss by fire.

—The Union Lumber Company, of Vancouver, B.C., have taken new offices in the Old Safe Block, 356 Hastings street, Vancouver.

—The Big Bend Lumber Company, of Arrowhead, B.C., will double the capacity of their saw mill this fall by adding new machinery.

—The Kwatsi Bay Lumber Company, Limited, has been incorporated by the British Columbia Government, with a capital of \$10,000.

—The logging camp of the Big Bend Lumber Company at Camborne, B.C., was destroyed by fire last month. The loss is estimated at \$5,000.

—The Imperial Timber & Trading Company, Limited, has been incorporated at Victoria, B.C., with a capital of \$25,000, to carry on a lumber business in all its branches.

—Bruce White has purchased the saw mill of the Active Gold Mining Company near Ymir, B.C., recently sold by the sheriff. The mill will be taken to the Molly Gibson mine.

—The Kamloops Lumber Company, Kamloops, B. C., have given notice of their intention to construct works for logging purposes on the Upper Sumas river and on Cherry, Frog and Tsuissus creeks.

—All the saws for the new saw mill of the Mundy Lumber Company, at Three Valley Lake, near Revelstoke, B. C., including those for their big double cutting band mill, have been supplied by the A. J. Burton Saw Company, of Vancouver.

—Galbraith & Sons, of New Westminster, B.C., have installed a new Johnston shingle machine in addition to their planing mill. It is intended to fill small local orders. They report a fairly brisk business this year in interior finish and other woodwork of a similar nature.

—The Mundy Lumber Company have started their mill at Three Valley Lake, near Revelstoke, B.C. It is a double cutting band, with a capacity of about 70,000 feet per day, the machinery having been supplied

by the Waterous Engine Works Company, of Brantford, Ont.

—The logging locomotive of A. Haslam, of Nanaimo, B. C., which has been under process of reconstruction by the Schaake Machine Works, has been returned to Mr. Haslam's logging camp on Vancouver Island, where it is now working satisfactorily. The locomotive was practically rebuilt and otherwise improved.

—Messrs. Robertson & Hackett, Vancouver, B. C., have had their saw mill shut down for some time for the purpose of installing three new boilers and the placing of the engine on a concrete foundation. They made further use of the time when the mill was shut down to make any necessary repairs to the plant, and it is now in thoroughly first-class condition.

—After fifteen years of idleness the old Ross-McLaren saw mill plant at New Westminster, B. C., is again in operation under the name of the Fraser River Saw Mill Company, and employing 250 men. Since 1890 not a wheel has turned in this fine plant until recently American capital took hold of the proposition and it will soon rank as one of the leading mills in Southeast British Columbia.

—The thirteen men employed at McWhinnie & Lwerke's logging camp near Port Neville, B.C., were recently called upon to save the camp equipment from destruction by fire. This was done by starting small controllable fires which burned out a wide path around the camp. Fires have been burning in the neighborhood and a considerable quantity of timber is believed to have been destroyed.

—The new saw mill of the Vancouver Lumber Company, Vancouver, B. C., is now nearing completion. The first two boilers of a battery of four, making 500 h. p., have been installed and are now steaming. These boilers were supplied by the Vancouver Engineering Works, who took the entire contract for furnishing and setting up these boilers. The machinery, most of which comes from the Allis-Chalmers Company, is being installed. Some of the planing mill machinery is being supplied by Cowan & Company, of Galt, Ont.

—The Fraser River Sawmills Company are negotiating with the City Council of New Westminster, B. C., regarding a method of providing satisfactory fire protection for the plant at Millside. It will be necessary to lay a special main. The management of the mills is also considering the installation of the sprinkler system, the elements of which consist of a large reservoir supplying a system of pipes running along the ceiling throughout the mill. These pipes are perforated, and upon an alarm being turned in, the contents of the reservoir flow through the pipes, sprinkling every part of the mill. It is said that the only plant in British Columbia at present equipped with this apparatus is the Vancouver Sugar Refinery.

TRADE NOTES.

Woods Limited, manufacturers of lumbermen's supplies, Ottawa, have decided to build a three-storey branch factory in Hull. Their business is growing very rapidly.

The Seaman-Kent Company, Limited, Meaford Ont., have installed an automatic feed pump and receiver and steam and oil separator built by the Smart-Turner Machine Co., Limited, Hamilton, Ont.

Walker Bros. have recently built a new foundry at Orillia, Ont. It is their intention to manufacture the type of gasoline engine designed by W. H. Croker. They will also give attention to general machinery and saw mill repairs.

The Canadian Drawn Steel Company have placed their order with the Smart-Turner Machine Company, of Hamilton, for one of their automatic feed pumps and receivers and a double press straightener for straightening shafting.

The Canadian Fairbanks Company, with head office in Montreal, have been licensed to carry on business in British Columbia. John E. Botterell, mechanical engineer, 153 Hastings street, Vancouver, has been appointed as their attorney.

The failure of N. Thompson & Company, founders and manufacturers of saw mill machinery, Vancouver, B. C., is much to be regretted. The total liabilities of the concern are \$127,421, and the assets \$112,677. The business is being offered for sale by John F. Helliwell, the assignee.

The Pierce and Pement Logging Company, of Blaine, Wash., have recently invested in another of the Vancouver Engineering Works Company's new 9 x 10 logging engines. It has been sent up to Deep Cove, B.C., where the company are at present carrying on logging operations.

The W. J. Campbell & Sons, of Ottawa, are building a very large plant on the corner of Broad and Wellington streets, and in the course of six weeks they will be all settled in their new quarters. The plant will be equipped with all latest and new machinery, which is being imported from Germany, for the manufacture of steam boilers of all descriptions.

The A. J. Burton Co. have secured the patent rights for Canada for the manufacture of the McLean patent saw tooth. E. C. Atkins & Co. have the American manufacturing rights. A description of this new saw tooth appeared in the June issue of the LUMBERMAN under the name of the "McKam" patent saw tooth.

The Schaake Machine Works, of New Westminster, B.C., are entering the American market with their shingle machines. An improved Johnston machine under the name of the "Modern" is being introduced there and is meeting with great favor among the shingle manufacturers of the American Pacific Coast.

RAILS and TRACK SUPPLIES

NEW and Re-aying from 12 to 60 lbs. per yard with fastenings; for Lumbering, Mining and Contracting Work. Immediate shipment from Stock. Get our prices before purchasing.

SESSENWEIN BROS.,

101 Shannon Street, Montreal

The Hanchett Swage Saw and Pressure Side Shaper

For Large and Small Circulars, Bands,
Band Resaws and Gang Saws

MILL MEN, FILERS

Our tools make a perfect shaped tooth. Widest on face—widest at extreme points. Leave the corners exceptionally strong. Your saws need less attention when fitted with these tools. They will enable you to increase your feed and output on a minimum saw kerf. Let us prove it to you. A trial will cost you nothing. Sent on approval anywhere. If they don't fill the bill—you to be the judge—return at our expense. That's fair, isn't it? Write for Circular "F." to

Hanchett Swage Works

Big Rapids, Michigan



Hanchett Saw Swage for Band Saws



Hanchett Pressure Side Shaper for Band Saw

FORESTRY DEPARTMENT

FORESTRY CONVENTION.

At a meeting of the Board of Directors of the Canadian Forestry Association held in Ottawa a few days ago, it was decided, subject to the approval of Sir Wilfrid Laurier, to hold the proposed Dominion Forestry Convention on the 10th, 11th and 12th January next. His Excellency has accepted the position of Honorary President, and in doing so expressed great interest in the Convention and his best wishes for its success. Sir Wilfrid Laurier will be the president, and the vice-presidents will be Hon. R. L. Borden and Sir Henri Joly.

Hon. Mr. Whitney has intimated that the Ontario Government will be represented at the convention, and it is expected that the other Provincial Governments will cooperate. The complete organization and preliminary programme will be announced later.

TRAINED FORESTERS IN DEMAND.

The demand for foresters is increasing rapidly both for State work and with private owners. Many States now have forest commissions, and several of them have State foresters. A trained forester at \$2,400 a year and two assistant foresters at \$1,200 each are wanted by California. Wisconsin wants an assistant forester at \$1,500, Indiana a forester to take charge of its state reserve, and Washington offers \$1,800 a year for a trained forester. In many other States the advisability of creating the office of State forester has been under discussion this year, and it is only a matter of a few years when such an official will be considered a regular part of an efficient State government.

The demand for foresters by private timber owners is growing at a still more rapid rate. During the last twelve months seven of the United States Bureau of Forestry force have left to take up work with such owners and four have accepted public positions—two with

Massachusetts, one Connecticut, and the fourth with Ontario, Canada. A number of other requests from private owners can not be met because men are not available. The year before there were less than half as many applications for trained men. But the demand for trained specialists in this line has only begun.

Large lumber companies, great wood manufacturing concerns, owners of extensive forests, railroad companies and others are taking a hitherto unknown practical interest in conservative forestry. They must have expert men to control their holdings. The result is that forestry is very rapidly taking its place as a recognized profession. A number of forest schools are training young men for this work, but the demand has outrun the supply.

J. D. McRae has leased John Knight's saw mill, Fourth Chute, Ont., and will operate it this season.

The Mogul Logging Company, of Whatcom, Wash., has been granted permission to do business in British Columbia, W. Martin Griffith, of Vancouver, being their attorney.

ELECTRICITY

If you desire to keep posted on the wonderful progress that is taking place in the use of electricity for an almost endless variety of purposes, you should subscribe to the

Canadian Electrical News
and Engineering Journal

A 44 PAGE MONTHLY,
PRICE \$1 PER YEAR

Write for free sample copy to

The G. H. Mortimer Publishing Co.

LIMITED

Toronto - Montreal - Winnipeg

PAT. OSCILLATING BOB SLED KNEE
Hauls 25 per cent. easier, and wears longer, and is lighter than all others.

THOMPSON MFG. CO., Ltd.,
Grand Bay, N. B.



Steel Frame

Dry Kiln Trucks

Plain or Roller

Bearing Wheels

Steel Frame Lumber Trucks

WRITE FOR BLUE PRINTS

MONTEITH, NIXON & CO.

Makers of Good Trucks

256 Macdonell Ave. - TORONTO

GIANT CAR MOVER

SEE THAT SLIDING WEDGE
IT BLOCKS THE WHEEL,



Manufacturers Price

\$3.00
EACH

B. & R. Patent

CASH WITH ORDER

Thousands of Testimonials.

See "THE RAILWAY EQUIPPER"
Our Monthly Publication. Mailed Free

M. MITSHKUN CO. DETROIT, MICH.

Larrigans - Leggins - Horse Collars

All manufactured by ourselves from leather tanned by ourselves.

Eminently suited to the LUMBER Trade

IF INTERESTED WRITE

THE R. M. BEAL LEATHER CO., LIMITED - LINDSAY, ONT.

Tanners of the Celebrated English Oak Harness Leather

PAROID ROOFING

FOR THE

PANAMA CANAL

The first proposals issued by the Isthmian Canal Commission called for Paroid Roofing, or equal, and the order was placed with us.

The U. S. Government again recognizes the standard qualities of Paroid, having used many carloads in this country, Cuba and the Philippines.

If you believe in quality, get our samples and booklet.

F. W. BIRD & SON, MAKERS,

HAMILTON, ONT.

Established in U. S. A. in 1817.

ADVERTISEMENT OF LUMBER INSURERS GENERAL AGENCY, 66 BROADWAY, NEW YORK

Soliciting Direct Applications for Insurance on Lumber

SOME ELEMENTS OF PRIVATE FIRE PROTECTION.

One of the indications of a well managed and thrifty lumber plant, yard or mill, is the care given to its private fire protection. Failure to preserve one's fire apparatus in the best condition is to render it worse than useless. From the standpoint of the insurance company, most underwriters would much prefer insuring, for example, a country lumber yard, free from exposure, where no pretense of private fire protection is made, and, therefore, subject to a higher rate of premium, than a yard seeming to have private fire protection, but the apparatus of which is old and degenerated.

The modern lumber yard has for its protection, aside from the town fire department, if it is in a municipality, barrels of water with fire buckets attached, 1 1/2" to 2" hose of sufficient length to reach all quarters of the yard, a number of hydrants communicating with the city water mains, fire extinguishers (used principally in buildings, such as lumber warehouses), "no smoking" signs, and a system, clock or the equivalent of American District telegraph, for checking the watchman's reports. Much might be said emphasizing the importance of the last four features, but the purpose of this article is to call attention to the importance of keeping buckets and barrels and hose in good condition.

The utility of barrels and buckets placed in a lumber plant is utterly gone within a few minutes after a fire has become a flame. If this element of modern fire protection is to count at all, it must be available at the emergency and most critical moment of the fire's existence. It is a common expression among underwriters that a bucket of water promptly and properly used at the beginning of a fire, is worth more than the city department. Imagine,

then, the predicament, if upon the alarm of fire, resort is made to the heretofore supposedly useless and apparently only ornamental fire barrels, the water in which has been allowed to evaporate without any reinforcement from the hands of a trusty watchman, janitor or yard man; or if you please, the buckets formerly suspended to which are nowhere to be found.

A prominent Pennsylvania manufacturer, who has several of the best protected lumber plants in the state, recently related his only experience with a fire. He had been in the lumber business for years, and never having had a fire had quite forgotten that he had once expended several hundred dollars for a private water system, and a lot of hose which lay neglected and uninspected on a shelf covered with dust. One oppressive July morning a small fire was discovered in the mill engine room, which was cut off from the main plant by a fire wall. An alarm was given and the two inch hose was attached to a nearby hydrant. The water was turned on but to the consternation of everyone who had responded to the call, the water pressure caused the hose to absolutely break asunder, rendering the fire crew helpless. What might have been a \$200 fire, confined to the engine room, became a raging conflagration, which swept over the large saw mill plant and six dwellings all over 125 feet clear space from mill. That experience taught one lumberman the lesson of diligent attention to his hose apparatus.

At this season of the year too much stress cannot be laid upon this subject. *Lumber Insurance* advocates the plan already in use by most of the policy-holders in the lumber insurance organizations, whereby one man is made responsible for keeping all water barrels filled to the brim and for keeping close watch as to the condition of hose attachments and hydrants.

LUMBER INSURERS GENERAL AGENCY

Managers of the leading

AMERICAN LUMBER INSURANCE COMPANIES

LUMBER UNDERWRITERS

LUMBER INSURANCE COMPANY OF NEW YORK

SAVING OF BI-PRODUCTS.

A small experimental plant has been erected in East Portland, near Inman, Poulsen & Company's mill, and from the waste wood is being manufactured turpentine, tar, pitch, charcoal, acid, gas and tar oil, and the quantities obtained are surprisingly large. Mr. Young, who devised the process, states that a plant twenty times as large would not have to leave Portland for a market. The wood is placed in a retort and heated lightly from a furnace or fire box. At the same time steam is admitted to the wood which causes the pitch

to melt and also liberates the turpentine and water in the wood. By a system of cooling pipes in the center of the retort the fumes and gases are removed in a condition suitable for further treatment at the stills. The pitch is drawn from the bottom of the retort, while the vapors, gas, etc., are passed through a condenser and rendered fluid. This fluid consists of turpentine, tar, tar oil and acid. These various properties are further treated to put them in marketable condition. The gases are conducted through a specially devised apparatus and the oils they carry are extracted and collected. From the acid is made a fruit

spray as well as several other products, such as acetic acid, creosote, shingle stain, etc. As a final, the charcoal is of great hardness and very superior to that made by the old methods. The statement was made that a cord of mill waste was worth more than an average 1,000 feet of lumber, and from what was shown it would appear as if this statement were not very far from the facts.—Portland (Ore.) Timberman.

P. PAYETTE & CO.

Manufacturers of Saw Mill and Engine Machinery and all kinds of Marine Machinery.

PENETANGUISHEVE, ONT.

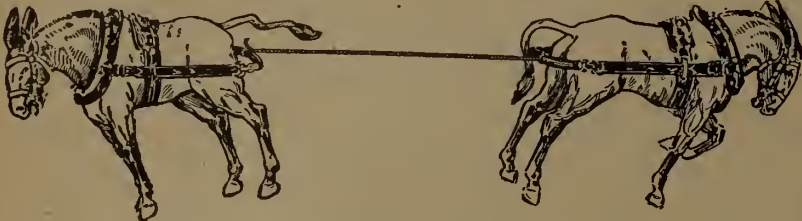

These Mules Cannot Break This Yarn

BECAUSE IT WAS MADE BY THE

Consumers Cordage Co., Limited

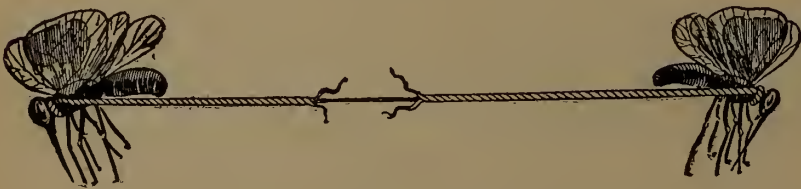

Poor Yarn is Dear at Any Price

We Manufacture

**Double and Single Lath Yarn,
Shingle Yarn, and Cordage**

Of Every Description

Our mills are equipped with the latest improved machinery for making extra long lengths of Transmission Rope.

CONSUMERS CORDAGE CO., LIMITED

Montreal and Halifax

New Sawmill Machinery FOR SALE



- One No. 1 Lane Mill R. H. Wood Frame. 16 ft. Carriage, Rope Feed, New.
- One No. O Lane Mill R. H. Wood Frame. 24 ft. Carriage Rack and Pinion Feed, New.
- One No. O Lane Mill R. H. Wood Frame. 25 ft. Carriage Rack and Pinion Feed, New.
- One 50 in. Circular Rip Saw, Shurley-Dietrich, New.
- One 2 Saw Trimmer, New.
- One Lockport Shingle and Heading Machine, New.
- One Double Edger, 3 Saw complete with End Tables, New.

MISCELLANEOUS

- 15000 ft. Sprocket Chain, all styles.
- 3000 ft. Manilla Transmission Rope.
- 5000 ft. Rubber Belting.
- A Large Stock of Pipe and Boiler Tubes.
- Wood and Iron Pulleys, Pillow Boxes, Hangers.

The above Machines are all new and are offered at prices that must compel attention.

The Manitoba Iron Works Co.

LIMITED

Logan Ave. W., WINNIPEG

THE LUMBER MUTUAL FIRE INSURANCE COMPANY

BOSTON, MASS.

STRENGTH

NET ASSETS, MARCH 31, 1904

\$672,021.10

ECONOMY

DIVIDENDS TO POLICY HOLDERS

33 $\frac{1}{3}$ %

MAIL EXPIRING POLICIES WITH YOUR ORDER.

VENEERS DUTIABLE AT 20 PER CENT.

An important decision was rendered recently by General Appraiser McClelland, to the effect that the Board of United States General Appraisers had sustained a protest by F. V. Vandergrift & Co., of Chicago, Ill., against the classification of very thin boards of high-class woods to be used for veneers, at 35 per cent. under the rules governing manufactures of wood. Appraiser McClelland ruled that this class of goods were dutiable at 20 per cent. under the provision for veneers of wood. This is a ruling of much importance to handlers of this class of goods.

BEECH FLOORING.

The once despised beech of the forest is fast coming into its own as a flooring material, and already ranks in third place as a material

for the making of hardwood floors. In quantity of output maple stands in first place, and the oak output is fast increasing to a good second position in volume of production. While the milling qualities of maple are very difficult, rendering the expense of floor making from it very high, beech is almost an ideal hardwood in its working qualities. Beech is not quite so dense a wood as maple, and its wearing qualities are not equal to it, but for many purposes it has all the advantages of its higher priced prototype, and possesses some advantages of quality not held by the other wood.

It is doubtful if handsomer flooring can be obtained from birch, cherry or even mahogany than can be secured from strictly red beech, which is the heart wood of the tree. The sap or white portion of the wood is not to be de-

spised, but the heart portion is infinitely its superior in wearing qualities and in its ability to resist decay.

Beech seems to stand better as a floor material than it does as a finishing wood. In this latter use it is quite prone to check and split, especially when used in pieces of considerable width. Beech flooring can be obtained for approximately the same price as soft wood floors of yellow pine, white pine or spruce of common grades, and from its superior quality is reaching a wide and rapidly increasing distribution.

C. H. VOGEL
 A. M. Can. Soc. C.E.
 OTTAWA, CAN. **ENGINEER**
 Surveys, Plans, Specifications and Supervision
WATER POWER
 Paper, Pulp and Sulphite Fibre Mills

The MAYOOK LUMBER COMPANY, Limited



MANUFACTURERS
OF

LARCH PINE AND FIR TIMBER



Head Office: MAYOOK, B. C.

WINNIPEG Office: 445 Main Street

Saw and Planing Mill at MAYOOK, B. C.



THE MOORE ROTARY PULP SCREEN

TAKES UP A MINIMUM OF FLOOR SPACE.
 REQUIRES ONLY 5 H. P. TO RUN IT.
 CAPACITY EQUAL TO FIVE DIAPHRAGM SCREENS.
 We Invite Enquiries from Pulp Mills.

THE JENCKES MACHINE CO., LIMITED
 Sherbrooke, Que.

“Doble” Tangential Water Wheels



AWARDED THE GRAND PRIZE AT ST. LOUIS WORLD'S FAIR

Tangential Water Wheels have been developed to meet the demand for large units of highest economy, close regulation and absolute reliability in service.

The John McDougall Caledonian Iron Works Co., Limited
 MONTREAL

Builders for Canada

Catalogue on Application

THE DYMENT FOUNDRY COMPANY

BARRIE, ONTARIO

Manufacturers of

Engines, Boilers Steam Feeds . . .

AND A COMPLETE LINE OF

Saw, Shingle and Lath Mill Machinery

Can ship mills in a week's notice. Write us for prices and Catalogue.

F. J. DRAKE'S SAW AND SHINGLE MILL MACHINERY

STATIONARY SAW MILLS
PORTABLE SAW MILLS
SHINGLE AND HEADING MACHINES
SHINGLE AND HEADING JOINTERS
TIE MILLS. SLASH TABLES
LATH AND PICKET MACHINES
LATH BOLTERS. LUMBER TRIMMERS
LOG JACKS AND CHAINS
SAW CUMMERS
DRAG SAW MACHINES
SHAFTING, PULLEYS, ETC.

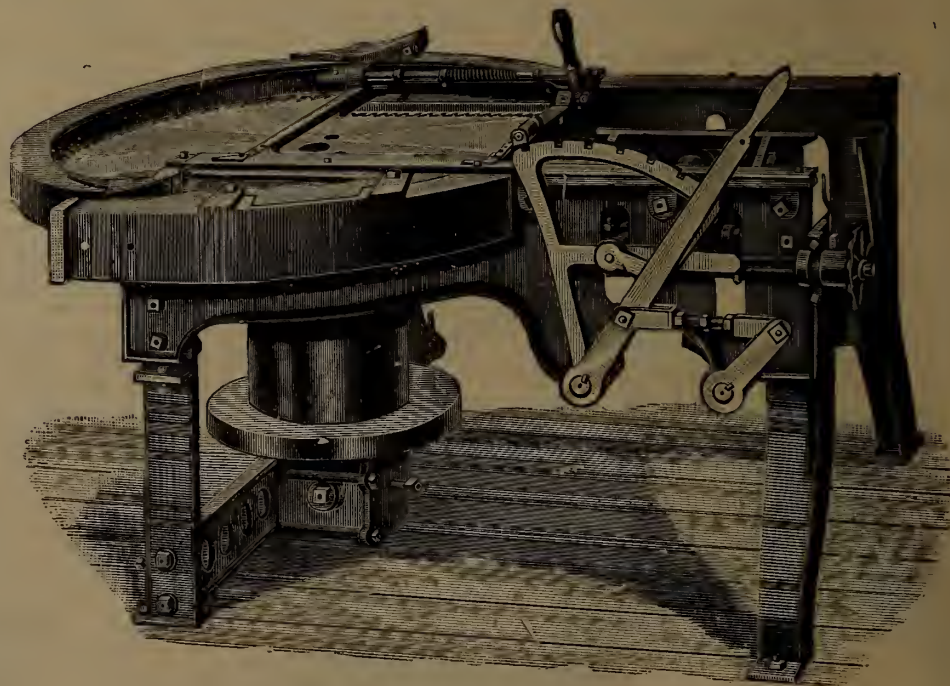

*Complete Outfits of Mill Machinery
at Bottom Prices*

Capacity 25,000 to 50,000 per day.

F. J. Drake,

BELLEVILLE,
ONTARIO

P. H. WRIGHT
 43 Bank Street, OTTAWA
Lumbermen's Agent
 All kinds of Mill and Bush
 help secured on short notice
 Telephone 2586

OILS
 Manufacturers High-grade Cylinder, Ma-
 chine and Sawmill Oils.
Calypsol Grease
 for Sawmill Purposes a Specialty.
 Our products are made from finest Penn-
 sylvania stocks.
 We solicit your correspondence.
 St. John St., **Commercial**
MONTREAL. Oil Co.,
 Offices and Works :
 Manchester, Eng. **Hamilton, Ont.**
 Hamburg, Germany.
 Newark, N. J.
 Chicago, Ill.

THE E. L. PURVIS CO.,
 18 COLBORNE ST., TORONTO, ONT.



PIPE AND BOILER COVERINGS
 Asbestos Mineral Wool
 and all kinds of Fireproofing
 Material Agents for
FAMOUS MICA COVERINGS

H. J. FRIEL
 EMPLOYMENT AND LUMBERMEN'S AGENT
 Bushmen supplied on short notice, also
 mill hands. Hotel help of all kinds procured.
Office: 73 BANK STREET
 Phone 721 - - - - - OTTAWA



Sole Canadian Agents - Prices Reduced
WATERLOO, BRANTFORD, CANADA

MAPLE LEAF
STITCHED COTTON DUCK
BELTING
DOMINION BELTING CO. LTD.
HAMILTON CANADA

WANTED

Supplies
Beech, Maple or
Birch Cutwood

To be air-dried and cut from Prime Clear Stock.
 11½" long x 7/8" and 15½" long x 1" x 1".

Also

Maple or Sycamore Squares
 From 1½" to 4" Square, rising by eights, and in
 multiples of 7" long up to 28".

Quote lowest prices per cubic foot deliver-
 ed c. i. f. Liverpool, England,
 to Box No. 50
CANADA LUMBERMAN

Rodgers Iron Mfg. Co.
MUSKEGON, MICH.

Write to us and we will tell you all about it. Read
 what they say—hundreds more like them.

Canton, N.Y., March 2, 1905.
 Rodgers Iron Mfg. Co.,
 Muskegon, Mich.
 Gentlemen:
 In reply to yours of the 29th ult. regarding combination
 gang edgers purchased of you. We consider this machine a
 great lumber producer and do not know of another machine
 that will do the work on four, five or six inch cants. Every
 board is perfectly manufactured and we have no trouble with
 thick and thin lumber from this machine.
 Yours respy,
 Woodhead.

West Monroe, La., Oct. 13, 1904.
 Rodgers Iron Mfg. Co.,
 Muskegon, Michigan.
 Gentlemen:
 We beg to hand you herewith, check to cover one edger
 and fixtures as per your invoice of July 15th.
 We are very well pleased with the machine and the work
 it is doing.
 Yours truly,

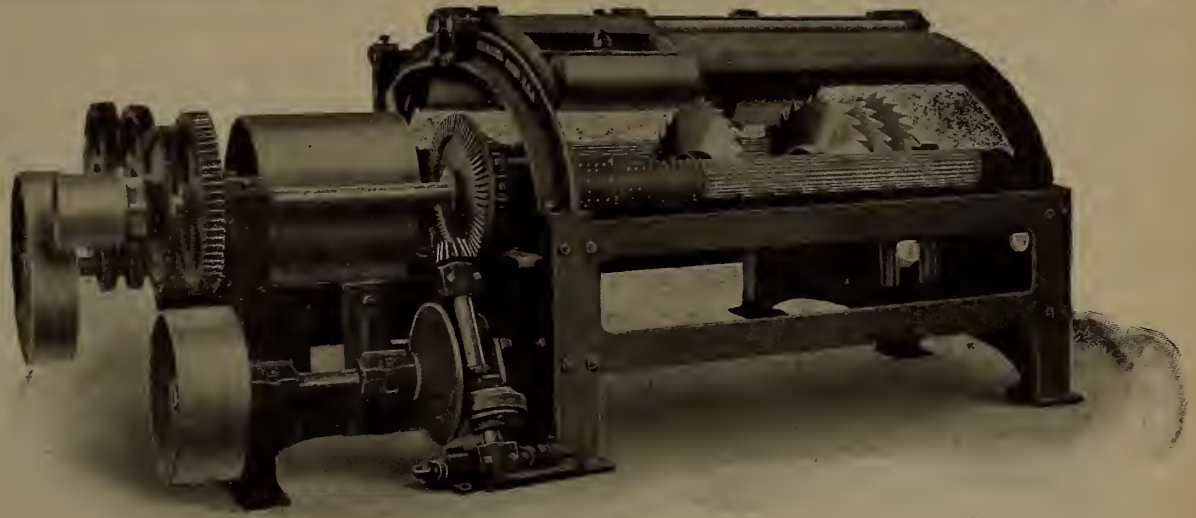

COMBINATION GANG EDGER WITH RIFT FLOORING ATTACHMENT

Special to Lumbermen, Miners and Railway Contractors



We are Manufacturers of :—Mince Meat, Baking Powder, Coffee, Spices,
 Flavoring Extracts, Mustards, Tomato Catsup, Worcestershire Sauce,
 Jams, etc., and all kinds of Grocers' Sundries for Camp Use. Also Sauer
 Kraut, Pickles and Sausage Meat.

Mince Meat put up in 75 Pound Tubs. ½ Barrels about 300 Pounds.
 Barrels about 600 Pounds.
 Sauer Kraut and Pickles in Barrels. Sausage Meat in 50 Pound Tins.
 Sauce and Catsup in 5 Gallon Pails.

ALL GOODS GUARANTEED
 . . Special Attention Given to Mail Orders . .



The Capstan Manufacturing Co., TORONTO, ONT., CAN.

SHERMAN'S FLOORING MACHINES

PATENTED

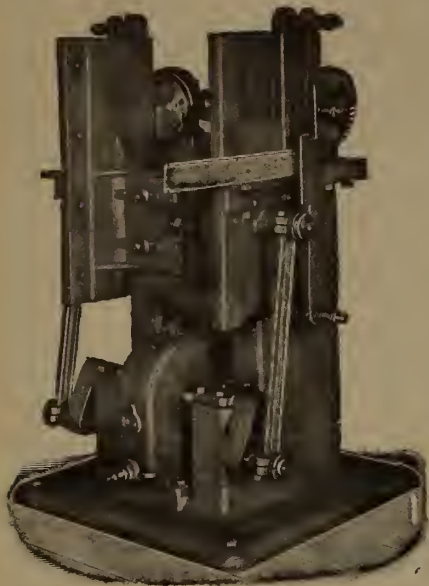

Above cut shows our End Matcher, the best machine in the market for end matching floor ing strips. They do rapid and accurate work, and are durable—therefore used by leading flooring manufacturers. Make your flooring profitable by end matching it.

We Make the **SHERMAN SIDE BORING MACHINES** and the **SHERMAN FACE BORING MACHINES**

To bore flooring while it is being run on the flooring machine. Write for circular and list of users

W. S. SHERMAN CO.
1150 Holton St., Milwaukee, Wis

Reliable Veterinary Remedies

No logging outfit is complete without a supply of reliable veterinary remedies. Getting the wrong kind means the loss of the use of your horses when time is valuable.

Johnson's Veterinary Remedies are guaranteed never to fail when used as directed. You get your money back if they ever do.

They are
Johnson's Horse Liniment No. 1.
A penetrating Alcoholic Liniment. Put up in one gallon jugs, with full directions, per imperial gal. \$4.50

Johnson's Horse Liniment No. 2.
A combination of the best oils used as liniments, imp. gallon . \$3.00

Johnson's Horse Colic Remedy.
A sure and speedy cure for colic. Imperial gallon \$5.00

Johnson's Veterinary Healing Ointment.
Positively the best all-round healing ointment made. In use by the largest owners of horse flesh in Canada. Put up in 2 lb tins, each . . \$2.00 or in 1/4 lb tins, per dozen . . \$3.00

Johnson's Condition Powders. (Concentrated).
Put up in bulk, per lb. . . . 3c.

These goods being put up in bulk are more economical than others, as cost of bottling, etc., is saved.

CAMP REMEDIES.

In addition to our Veterinary Remedies we make a line of medicines for lumbermen, including a strong, penetrating liniment, healing ointment, cholera cure, liver pills, cough syrup, in fact anything in the form of Camp Drug Supplies. We know that there are no better remedies made than those we offer. There may be others nearly as good, but they lack our guarantee. Satisfaction or money back. A trade discount of 10% allowed off all orders amounting to \$100.

Send postal for printed matter.

A. H. JOHNSON
Wholesale Druggist
Collingwood, Ont.

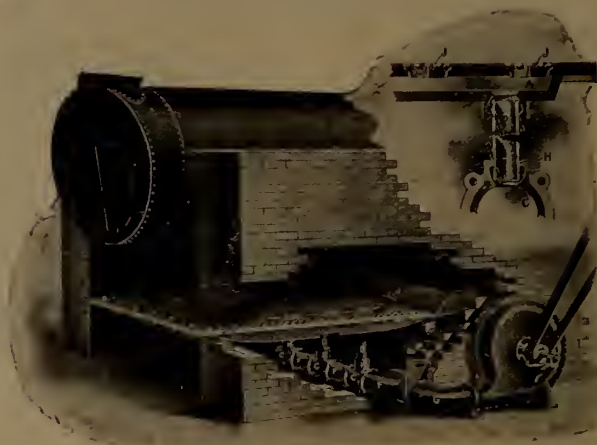

The Gordon Hollow Blast Grate Co.
Greenville, Michigan

SOLE MANUFACTURER OF

THE GORDON HOLLOW BLAST GRATE

AND

THE FAMOUS "TOWER" LINE

OF

EDGERS AND TRIMMERS

The Gordon Hollow Blast Grate makes two boilers do the work of three, gives as good results with wet, green or frozen sawdust or other refuse as a draft grate gives with dry wood, and saves labor in firing. We pay the freight. Sold on approval, and returnable at our expense, if unsatisfactory.

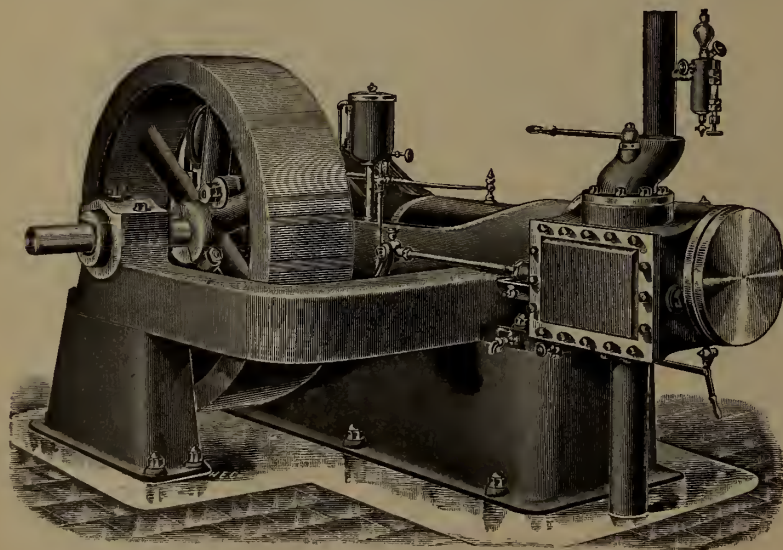

Our Engines are fitted with Automatic Governors and run at Regular Speed, whether Loaded or Light.

They use about 25 Per Cent Less Steam than the best engines with a throttling governor.

They are built on the Interchangeable System so that duplicate parts exact in fit can be supplied at any time.

In Sizes up to 125 Horse Power the outboard bearing is attached to the frame, as shown in the cut, keeping it perfectly in line.

ROBB ENGINEERING CO., LIMITED
Amherst, N.S.

Gonnell & Dengler Machine Co.

ROCHESTER, N. Y.

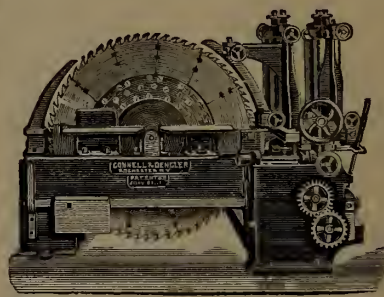

44 inch Circular Re-Saw.



60 inch Band Re Saw

Manufacturers of . . .

Box Makers' and Planing Mill Machinery



Heavy 26 inch Divided Roll Planer and Matcher with 8 Feed Roll.

STEAM NIGGER

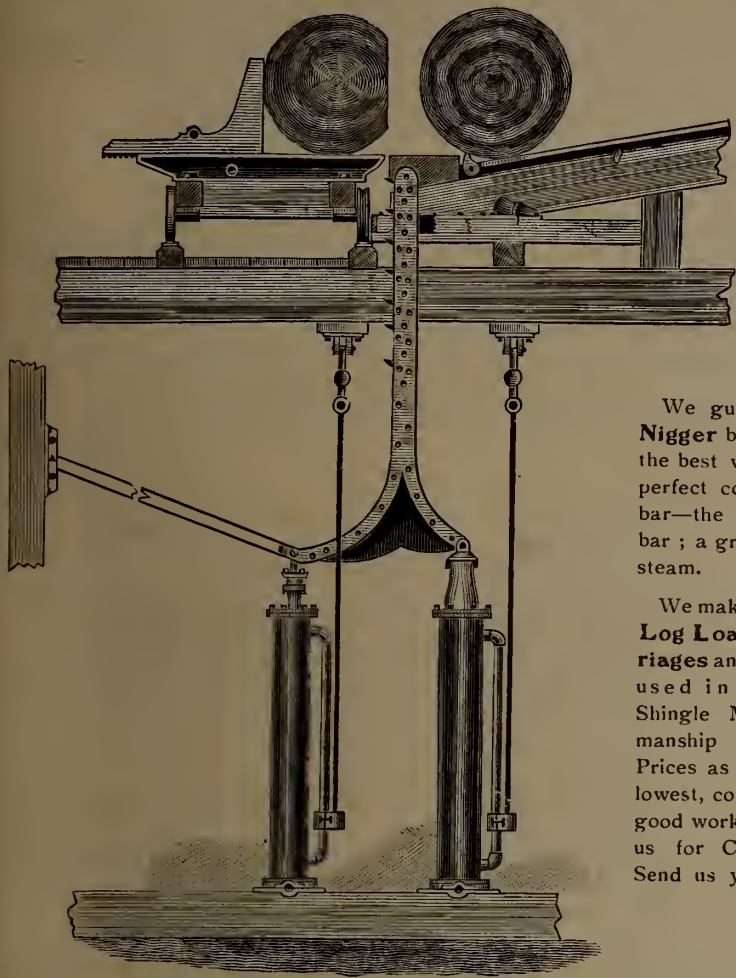

We guarantee this Nigger because it has the best valve made; perfect control of the bar—the best type of bar; a great saver of steam.

We make Kickers, Log Loaders, Carriages and everything used in a Saw or Shingle Mill. Workmanship guaranteed. Prices as low as the lowest, consistent with good work. Write to us for Catalogue. Send us your orders.

B. R. MOWRY & SONS,
GRAVENHURST, ONT.

THE ORIGINAL AND ONLY PERFECT CHISEL-TOOTH SAW

ALL OTHERS ARE IMITATIONS.



GOLD MEDAL (HIGHEST AWARD)
ST. LOUIS, 1904.

SEND FOR NEW ILLUSTRATED CATALOGUE,
WITH NEW PRICES AND NEW DISCOUNTS.

R. HOE & CO.

504-520 GRAND STREET,
NEW YORK, N. Y.

ADAM HALL,

PETERBOROUGH, ONTARIO
CANADA

MANUFACTURER OF . . .

STEEL RANGES

For Lumbermen's and Railway Camps, Boarding Houses and Hotels

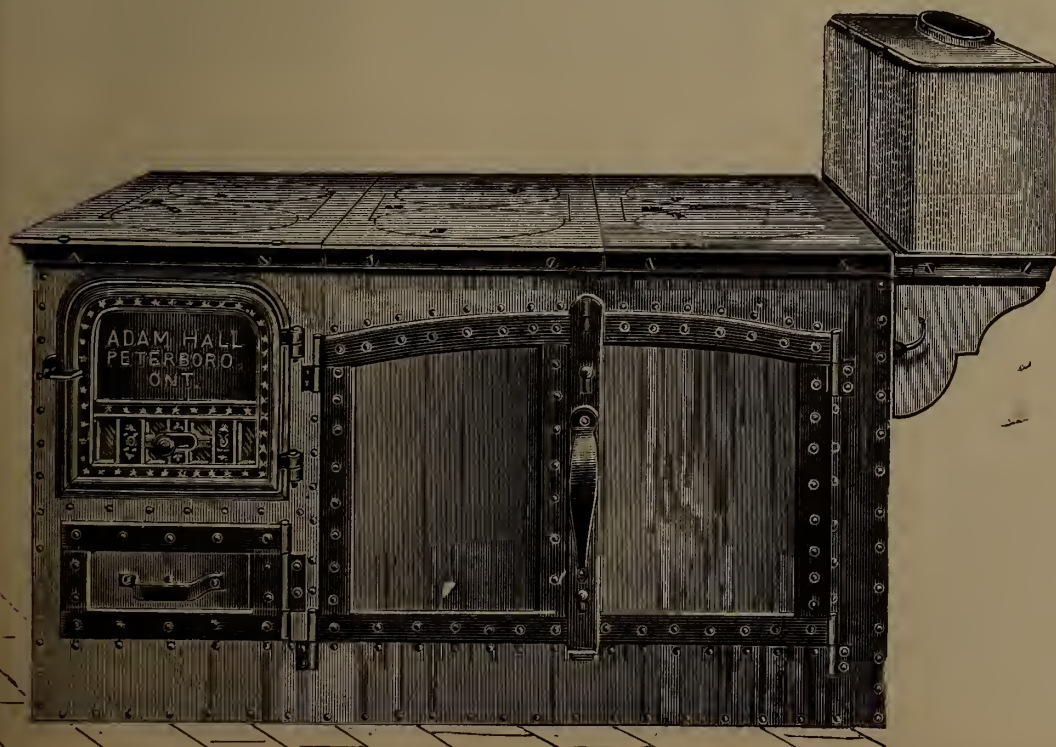

Lumbermen's Six Pot Hole Range with Reservoir.

The Lumberman Heater

- 36 Inch Lumberman Heater
- 42 Inch Lumberman Heater
- 48 Inch Lumberman Heater

This Heater is used in heating Lumbermen's Camps Boarding Houses, School Houses and large buildings.

The body of the Heater is made of Heavy Boiler Plate. The ends are made of Heavy Cast Metal, with a large Fire Door.

It is a perfect Heater, and very durable.

We have been manufacturing Steel Ranges and Heaters for Lumber Camps for the past Twenty-four Years, and have supplied the wants of nearly all the Lumbermen in Quebec, Ontario and Manitoba—they are unexcelled for Baking and Cooking, and are strong and durable.

This No. 10-25 Range with 25 Gallon Copper Reservoir is the one we sell the most of, owing to the convenience of having a supply of hot water at all times. Will cook for 50 to 60 men. Weighs 450 pounds.

Write for Catalogue and Price List.

Dundas Lumberman

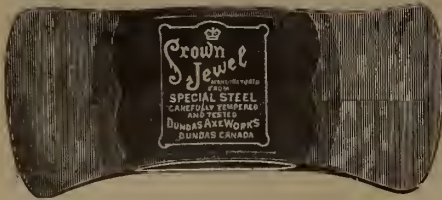

A New Axe tempered by a new process which enables us to submit to any lumberman three or more samples of Axes, all different degrees of hardness, and on a selection being made we will guarantee to furnish any number all exactly the same temper as sample chosen.

THE DUNDAS AXE WORKS
Dundas, Ont.

FOR THE CAMP TABLE

- Mess Pork
- Short Cut Pork
- Plate Beef
- Dressed Fresh Beef
- Long Clear Bacon, Butter, Cheese, &c.
- Smoked Hams
- Roll Bacon
- Pure Lard
- Pork Sausage

Write us for Special Prices on Car Load Lots.

THE PARK BLACKWELL CO., L'T'D
PORK AND BEEF PACKERS
TORONTO



Let Us Lend You a Hand in Making Shingles

We know something about the game of shingle making. Been at it—perfecting shingle making machinery for over 29 years, and we're not stretching the truth a particle when we say our line of Hand Feed, Single, Double and Ten-Blockers is without a peer on the market.

No matter what kind of a Shingle Machine you buy,

IF IT'S A "PERKINS"

you can rely on getting more and better shingles from the same stock and with less trouble and expense than with any similar machines. Cut shows our celebrated COLUMBIA SINGLE-BLOCKER—the champion one-blocker of the world. Write for catalog explaining our full line.

PERKINS & CO. - Grand Rapids, Mich.



MANUFACTURERS OF
INSERTED, SHINGLE, AND ALL SOLID-TOOTH CIRCULAR

SAWS

WHAT THE LEADING MILLMEN SAY OF OUR SAWS:
THE A. J. BURTON SAW CO., CITY. VANCOUVER, B. C., March 25th, 1905

DEAR SIRS, Since you commenced your saw manufactory here, we have been users of your Saws in various parts of our plant, and we have yet to experience a failure in any saws we have got from you; all of them are running well and giving good satisfaction. We have been hoping for years past that a Saw manufacturing plant would become established in Vancouver, and are glad that you have made so successful a start, and also glad to hear from other lumber and shingle manufacturers that your saws have been very satisfactory. We wish you every success.

Yours truly,
PACIFIC COAST LUMBER CO., LTD.,
(Signed) J. G. SCOTT, Mgr.

HOE BITS AND SHANKS AND ALL FILE-ROOM SUPPLIES
OLDHAM BAND SAWS

Repairs Executed Promptly. Inserted Tooth Saws Remilled and Refitted

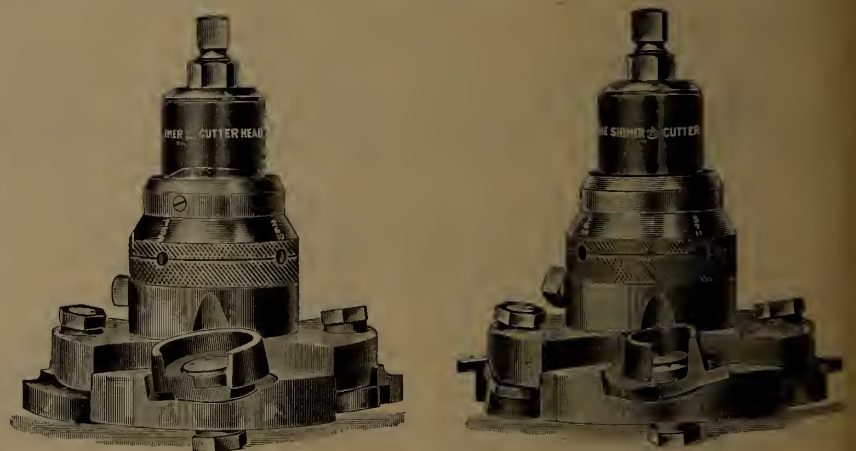

The Shimer Gutter Head

FOR FLOORING, CEILING, SIDING, SHIP LAP,
JOINTING, DOUBLE CEILING, DOORS, SASHES,
BLINDS, etc. SPECIAL TOOLS for Special Service

Should appeal to every user of a Matching, Moulding or Tenoning Machine because it does more and better work than others and requires less labor and expense to keep it in order.

We make it of every size and style to fit any machine and send on trial 30 days to responsible lumbermen.

Send for our 1905 Catalogue. It gives illustrations and complete description of a number of these tools, some of which will be of advantage to you.

SAMUEL J. SHIMER AND SONS
Milton, Pennsylvania

Perfect Swing Shingle Mill

Fitted with our "Automatic Trip."

Best Swing Shingle Machine on the Market today for cutting Shingles, Headings, Etc. . .

It will pay you

to write for description and price before placing your order.

We also Manufacture a complete line of . . .

SAW MILL MACHINERY, ENGINES AND BOILERS

THE **Owen Sound Iron Works Co. LIMITED**
Owen Sound, Ont.

SEND FOR CATALOGUE

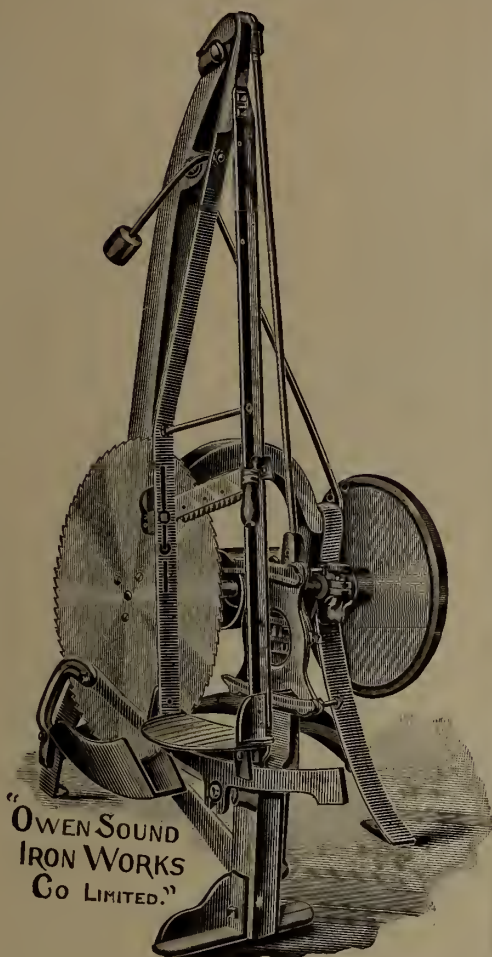

"OWEN SOUND IRON WORKS CO LIMITED."

RUBBER BELTING

For Transmitting Elevating and Conveying



Rubber Hose for Water Steam Air Suction Fire Protection

THE GUTTA PERCHA & RUBBER MFG. CO. OF TORONTO, LIMITED.

HEAD OFFICES: 47 YONGE STREET, TORONTO, CAN.
Branches: Montreal, Winnipeg.

New 200 Page Green Book 1904 EDITION.

"Saw and Knife Fitting Machinery and Tools"

MAILED FREE ON REQUEST.

A Book for Mill and Factory Managers, Superintendents, Foremen and Saw Filers.

BALDWIN, TUTHILL & BOLTON,
GRAND RAPIDS, MICH., U.S.A.



B. T. & B. Full Automatic Knife Grinder. Style D3
SAW AND KNIFE FITTING
THE NEW B. T. & B. MANUAL

Revised edition. 144 pages. Copiously illustrated and Durably Bound. Is an exhaustive treatise on the care of Saws and Knives.

A Practical Book for Saw Filers.

Mailed Postpaid on Receipt of Price

\$2.00

THE "B. T. & B." LINE

NEED ANYTHING ?

- Sharpeners, Swages, Stretchers, Shapers, Side Files, Shears, Retoothers, Brazing Machines, Filing Clamps, Lap Grinders, Lap Cutters, Patch Machines, Crack Drills, Hammering Benches, Bench Grinders, Band Filers, Band Setters, Pulleys and Stands, Brazing Forges, Saw Sets, Saw Gauges, Swage Bars, Upsets, Straight Edges, Tension Gauges, Back Gauges, Leveling Blocks, Anvils, Hammers, Speed Indicators, Emery Dressers, Knife Grinders, Knife Balances, Shingle Saw Grinders, Burr Gummers, Post Brackets, Stretcher Bench Brackets, Cutters, Marking Stamps, Saw Guides, etc.

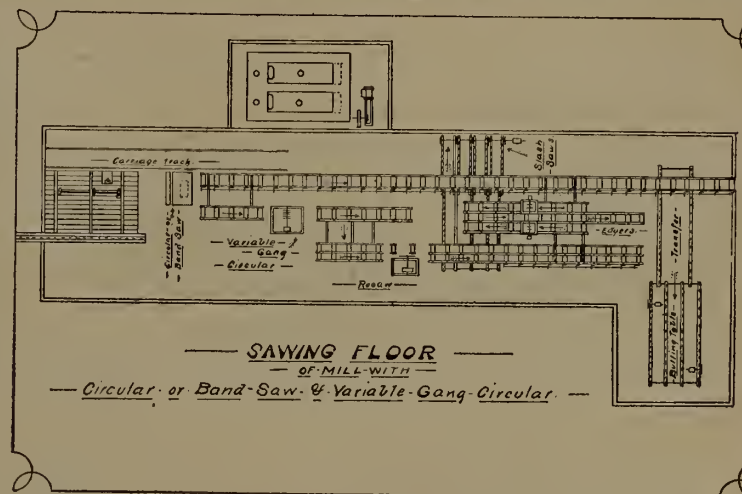

Sawing Floor of Mill with Circular or Band Saw and Variable Gang Circular

For cutting large and small logs at the same time, profitably, this mill has no equal. The variable Gang Circular (which takes the place of an upright gang, does as much work, and can be placed for 1/2 the cost of an iron frame gang) cuts the cants into any thickness from 1" to 9" by whatever width the cant has been slabbed to up to 10", and each cant put through may be cut into different sizes from the one immediately preceding or following it. Plans and estimates made of all kinds of sawmill work; machinery supplied and mills built if desired.

I. N. KENDALL

203 BRIDGE ST.

OTTAWA, ONT.

OUR BIG CHAMPION EDGER

is the Heaviest and Most Substantial
Edger Built in Canada

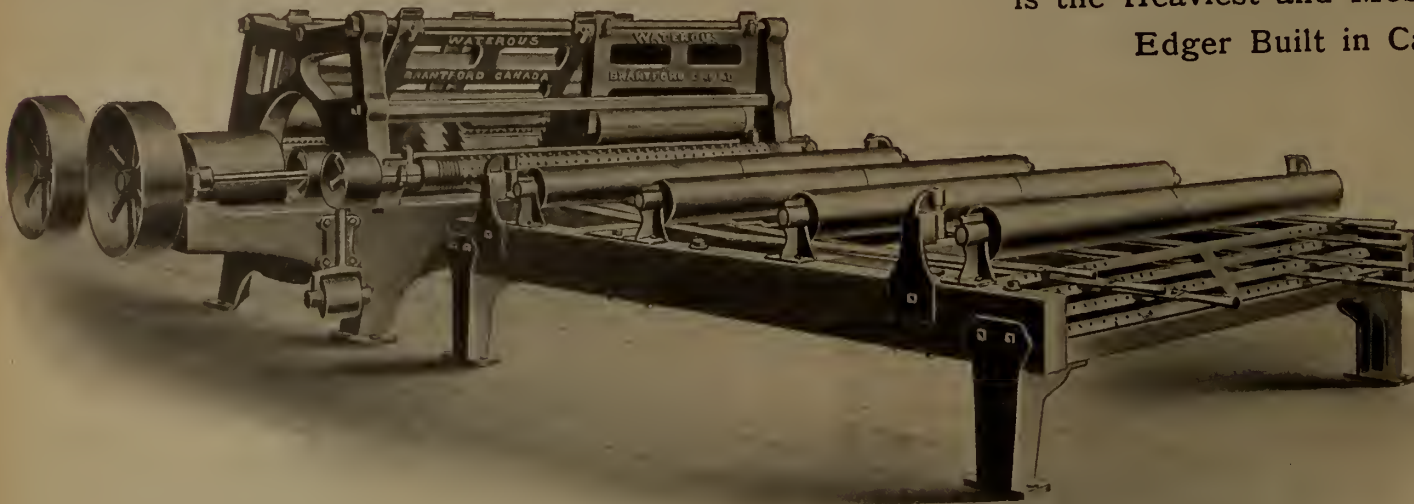

In Five Sizes, from
54 to 96 inch

Can be arranged with
Cluster Collar and
Variable Feed

Usual Speed of Feed,
360 feet per minute

FRONT VIEW—shows adjustable tightener for feed belt to outer rolls. Has three water-cooled boxes—two at driving end—all detachable. All bearings piped for water connections. A most positive feed is secured by one spiked and one fluted roller in front and rear—all driven. Saws 26 inch in diameter. All are movable and guide roller stationary. The special lever arrangement shown in cut is the best known method for moving saws, being so arranged that the pressure on saw is always parallel, notwithstanding angle of lever, and lever is so wide there is no side spring, so that the movement of saws is absolutely correct.

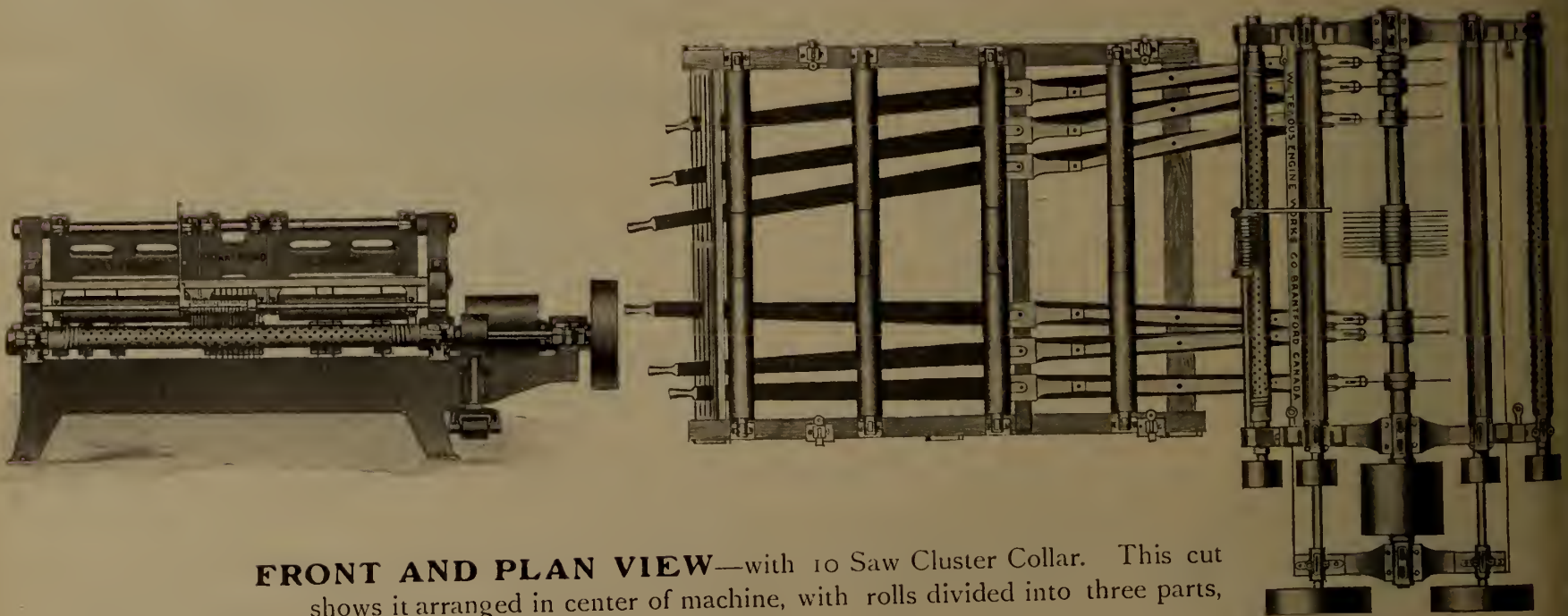

FRONT AND PLAN VIEW—with 10 Saw Cluster Collar. This cut shows it arranged in center of machine, with rolls divided into three parts, can be placed at either side if preferred.

A special Variable Feed Works is required below edger floor, so that when heavy cutting is being done with Cluster Collar the operator can by a lever reduce feed instantly to such a reduction as feed is arranged for, generally to 150 feet per minute.

Send for Special Circular and Price

WATEROUS, Brantford, Canada

NATURAL DRAFT MOIST AIR . . . **DRY KILNS**

LUMBER TRUCKS and TRANSFER CARS

Write for prices and particulars of the most simple and efficient Natural Draft Dryer on the market. Testimonials and list of users sent on application. Every square inch of heating surface is utilized to the uttermost and perfect ventilation and circulation is obtained by a very simple arrangement of ducts. Write for particulars to

SHELDON & SHELDON,
GALT, ONT.

FORMERLY McEACHREN HEATING & VENTILATING CO.



Experimenting with Dry Kilns is an Expensive Luxury

Why keep on using a Kiln that has to be regulated with dampers, chimneys and complicated fans. Put in a Morton Automatic Moist Air Kiln and your Dry Kiln troubles will be ended. We do not sell a man a Dry Kiln to dry Mahogany and then tell him it will dry Basswood staves. Our thirty years experience in the Dry Kiln business yours for the asking.

Write to-day for Illustrated Catalogue "C"

The A. H. Andrews Co.

174-176 Wabash Avenue - - CHICAGO, U.S.A.
Eby Machinery Co., Western Agents, 17-19 Main St., San Francisco, Cal.
H. G. Boardman, Eastern Agent, 1170 Broadway, New York.



McEACHREN HEATING & VENTILATING COMPANY, GALT, CANADA

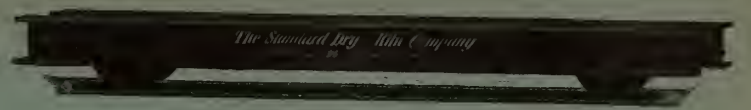

THE HIGHEST ACHIEVEMENT IN TRUCK CONSTRUCTION

Standard Dry Kiln Trucks are best for your plant because they run more lightly, give less trouble and last longer than any other truck on the market. This we prove and guarantee.

Not only do they possess every modern feature of truck construction, but a number of the most valuable points about them are patented by us and cannot be reproduced in other trucks.

Standard Trucks have malleable iron wheels and spreaders; channel steel frame; steel rollers with cone-shaped ends that minimize the friction; lathe-cut axles with milled ends, and many other advantages that are explained and illustrated in our printed matter.

Write for our Catalogue "D" and learn more about these better dry kiln trucks.

The Standard Dry Kiln Co.
Indianapolis, Indiana

SAW MILL OPERATORS are finding that

"MIDLAND" BEARING METAL

is all that WE CLAIM FOR IT

and then it is sold for only

15 CENTS A POUND

You will be pleased if you will give us a trial order

GEORGIAN BAY ENGINEERING WORKS

Midland, Ontario

FOR **DRY KILNS**

that will season lumber of all kinds and under all conditions, whether partially air-seasoned or green from the log, in shortest time and at least cost, entirely free from checking, warping or case hardening,

Write to—

HUTHER BROS. PATENT GROOVER OR DADO HEAD
For cutting any width groove from 1/4-inch to 2 inches or over

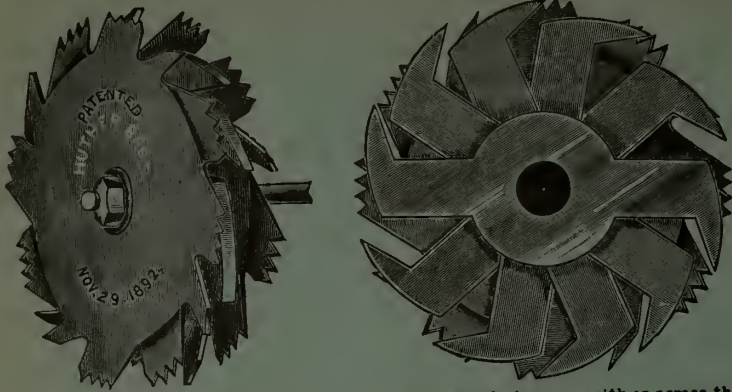

Can be used on any Circular Saw Mandrel. Will cut a perfect groove with or across the grain. This is the only Dado Head on the market that gives entire satisfaction on all classes of work. No screw adjustment. For different width grooves, simply remove or add inside cutters. Sold by builders and dealers of woodworking machinery in all parts of the United States. Will send on approval, in competition with any other make on the market; if not the best return at our expense. **HUTHER BROS.**, Platt Street, ROCHESTER, N.Y., manufacturers of Circular Saws, Morgan Pattern Lock-Corner Box Cutters, Concave Saws, etc.



**AUTOMATIC
FEED PUMP AND
RECEIVER**

**STEAM and POWER
PUMPS**

**ENGINES
BOILERS**

**THE
SMART TURNER
MACHINE COMPANY**
Limited.
Hamilton - Ontario

Uncle Sam would not allow his battleships to be babbitted with inferior babbitt metal. New Battleship "Nebraska" is lined with Syracuse Babbitt. Always specify best. It is cheapest in the long run.

SYRACUSE SMELTING WORKS
MONTREAL NEW YORK SEATTLE

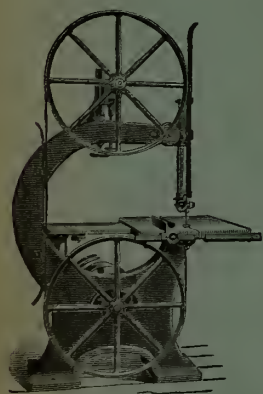

CRESCENT MACHINERY
Quality is all right.
So's the price.
**Band Saws
Jointers
Saw Tables**
Very low price on
BAND SAW BLADES
Catalogue tells the rest.
H. W. PETRIE
Dept. C. M.
TORONTO, ONT.



Rice Lewis & Son,

Dealers in _____ LIMITED

BAR IRON AND STEEL

BOOM AND LOGGING CHAINS MADE TO ORDER

TORONTO

Write for Prices.

**THE
LEATHER
BELT
THAT'S
KNOWN**
**OUR
"EXTRA"**

MONTREAL WINNIPEG TORONTO VANCOUVER

PINK LUMBERING TOOLS

The Standard Tools

In Every Province of the Dominion, * * * * *
* * * * * New Zealand, Australia, Etc.

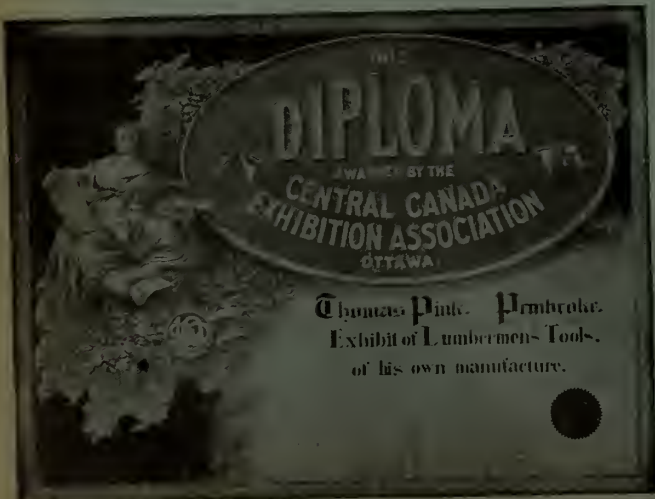

THOMAS PINK
Pembroke, Ont.



Pink Round Bill Peavey, Handles in Split Maple

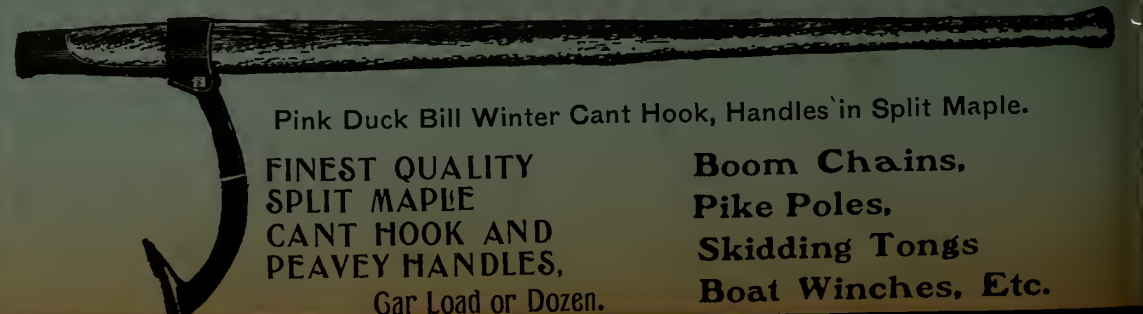

Pink Duck Bill Winter Cant Hook, Handles in Split Maple.

**FINEST QUALITY
SPLIT MAPLE
CANT HOOK AND
PEAVEY HANDLES,**
Gar Load or Dozen.

**Boom Chains,
Pike Poles,
Skidding Tongs
Boat Winches, Etc.**

THE CANADA LUMBERMAN AND WOOD-WORKER

REACHES REGULARLY THE MANUFACTURERS AND BUYERS AND SELLERS OF TIMBER PRODUCTS IN EVERY PART OF CANADA AND LEADING IMPORTERS

VOLUME XXV. }
NUMBER 9.

TORONTO, MONTREAL — SEPTEMBER, 1905 — WINNIPEG, VANCOUVER

{ TERMS, \$1.00 PER YEAR
Single Copies, 10 Cents.

SNOW PLOWS

Logging Sleighs
Heavy Waggon

THE WILKINSON PLOUGH COMPANY, LIMITED
TORONTO, CANADA



LEATHER BELTING

It isn't the price, its what you get for the price, that counts.

J. L. GOODHUE & CO.,
DANVILLE, QUEBEC.

D. K. McLaren
GENUINE

Oak Belting
MILL SUPPLIES

751 Craig St., Montreal,
196 King Street West, Toronto
169 Prince William St., St. John, N. B.

WOODS LIMITED

.. Wholesale Manufacturers of ..

LUMBERMEN'S AND CONTRACTORS' SUPPLIES

INCLUDING

Tents, Flags, Awnings, Tarpaulins, Clothing,
Overalls, Shirts, Mitts, Underwear, Blankets,
Axes, Moccasins, Woods Celebrated Eider
Down Sleeping Bags

WOODS BUILDING - OTTAWA, CAN.

SEND FOR H. W. PETRIE'S
MONTHLY STOCK LIST
NEW & 2ND MACHINERY
TORONTO, CANADA

DICK'S BELTINGS



Never is affected by wetness, and does not stretch

Excels in Transmission Power

Always Uniform.

LARGE STOCK ON HAND

WRITE TO SOLE AGENTS :

J. S. YOUNG, 14 Hospital Street MONTREAL

ROPE

WIRE ROPE
and
MANILA ROPE

Also a complete line of Fittings carried in stock
W. H. C. MUSSEN & Co.
MONTREAL

MANUFACTURERS OF

HIGH GRADE
CIRCULAR AND LONG SAWS
UNEXCELLED
SHINGLE SAWS



The Wm. Hamilton Mfg. Co., Limited

Builders of a Complete Line of

SAW MILL MACHINERY

We are specialists in the building of sawmill machinery—we have been making it, and making it well, for nearly fifty years.

Surely our machines must have merit—must have lived up to all our claims, or we would not be in business to-day.

Back of every machine we sell is our guarantee against its failure due to defective material or workmanship, and our warranty of its successful operation.

All our machines are of simple design and enduring construction.

We are specially well equipped for handling repair jobs, and can give your orders prompt attention.

Can we not send you our catalogues?
Write Department L for them.

Our Line Includes

Engines and Boilers

Band Mills

With Weight or Steam Tension

Gangs

Carriages

Husk Frames

Log Handling Machinery

• Edgers

Trimmers and Slashers

Steam, Hand and

Power Set Works

Lath Mill, Shingle Mill

and Filing Room Machinery

Twin Circulares

Tie Mills

Burners

Head Office and Works: PETERBOROUGH, ONTARIO

Allis-Chalmers-Bullock, Limited

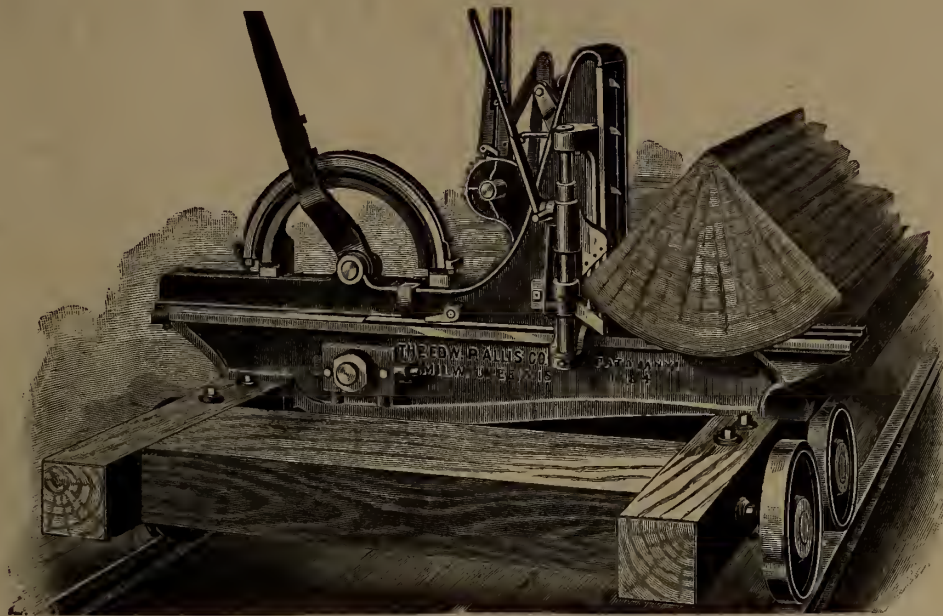

A QUARTERED LOG DOG.

A right-hand dog is shown holding the timber in position for the saw.
Send for our latest leaflets on circular saw mills, horizontal band resaw mills, six foot band mills, new Allis vertical valves for steam feeds and No. 2 heavy timber edger.

Works : Montreal. Branch Offices : Halifax, Toronto, Winnipeg, Nelson, Vancouver

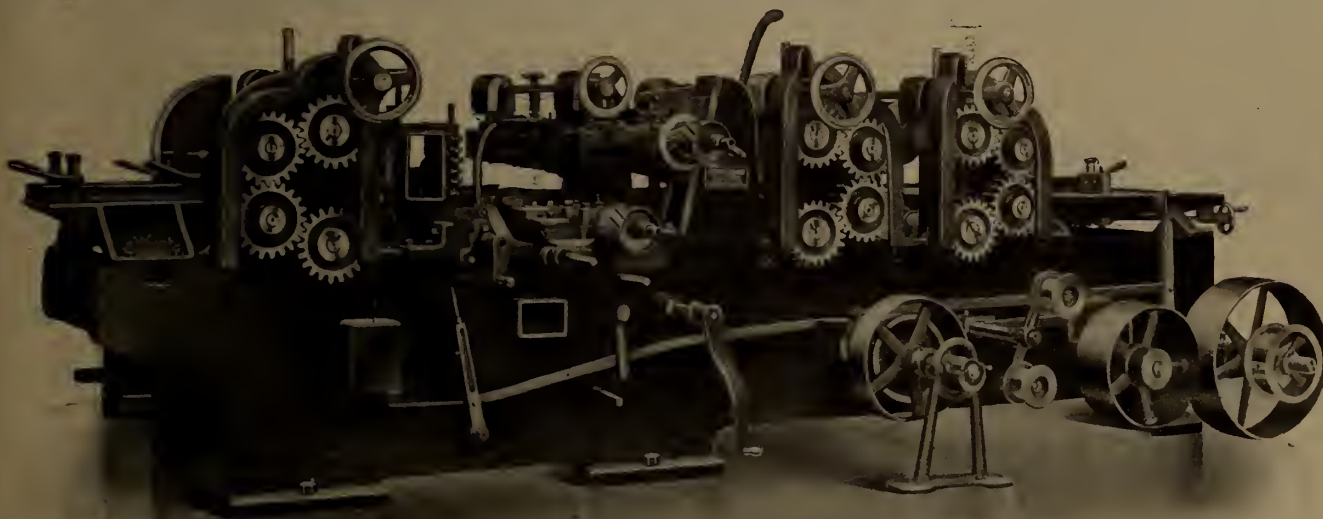

PLANER AND MATCHER

M 169

Made in several sizes ; all fitted with wedge platen for instantly adjusting, regulating and distributing the cut between the cylinders ; the greatest labor saver embodied in planing mill machinery. We manufacture a full line of wood working machinery. Write for prices and particulars.

COWAN & COMPANY
OF GALT, LIMITED
GALT, - CANADA



Fairbanks' Wood Split Pulley—Made in Canada

Belting, Pulleys, Shafting Hangers, Files, Drills

Emery Wheels, Belt Hooks, Lace Leather

IN FACT EVERYTHING FOR THE MILL

SEND US YOUR NEXT ORDER

THE CANADIAN FAIRBANKS CO., LIMITED

MONTREAL

TORONTO

VANCOUVER

WINNIPEG

BRITISH COLUMBIA LUMBER AND SHINGLE MANUFACTURERS

The Canadian Pacific Lumber Co., Limited
PORT MOODY, B. C.

Manufacturers and Wholesale
Dealers in All Kinds of

B. C. LUMBER, LATH, MOULDINGS, ETC.

Special Attention Given to Orders from Manitoba and the Territories † Long Distance Telephone Connection. † Address the Company at Port Moody or BYRNES & CUDDY, Selling Agents, WINNIPEG

PETER LUND, Managing Director.

J. BRECKENRIDGE, President.

MANUFACTURERS OF
ALL KINDS OF

Grows Nest Pass
Lumber Co., Limited
WARDNER, B. C.



BUILDING MATERIAL

Capacity 150,000 Feet Per Day.

Columbia River Lumber Company, Limited
HEAD OFFICE AT GOLDEN, B. C.

Largest Capacity in Mountains

MILLS AT { GOLDEN, B. C.
BEAVER, B. C.
KAULT, B. C.
CARLIN, B. C.

ROUGH AND
DRESSED

LUMBER

FIR, SPRUCE
CEDAR AND PINE

LATH

Telephone Poles,
Piling, Etc., &
Specialty.

The Fernie Lumber Co., Limited, Fernie, B. C.

MANUFACTURERS OF AND DEALERS IN ALL KINDS OF

ROUGH AND DRESSED LUMBER

Dimension and Bridge Timber a Specialty.

Moulding in Stock or Made to Order.

JOS. GENELLE, Manager.

J. G. BILLINGS, Secretary.

THE YALE-COLUMBIA LUMBER COMPANY, LIMITED

Head Office: NAKUSP, B. C.

Mills at Nakusp, Westley and Cascade, B. C.

MANUFACTURERS OF

DEALERS IN

All Kinds Rough and Dressed Lumber,
Mouldings, Lath, Etc.

Cedar and Fir Piles, Telephone and
Telegraph Poles, Fence Posts, Etc.

NORTH STAR LUMBER COMPANY,

Head Office and Shipping Yards: ELKO, B. C.

Mills: CRANBROOK, B. C.

At present we have the following material in stock at Cranbrook, B. C. :

- 1,750,000 ft. Common Boards.
- 300,000 " Stock Boards, 8 in., 10 in. and 12 in.
- 300,000 " Shiplap, 8 in., 10 in. and 12 in.
- 100,000 " Flooring, Siding and Ceiling, 4 in. and 6 in.
- 1,550,000 " Dimensions, 8 to 24 ft.

We have a large quantity of 18 and 20 ft. lengths, from 2 x 4's to 2 x 12's.

The above is manufactured from a superior quality of pine, fir and tamarack logs. 75 per cent. of it is "bone dry."

Special sized timbers cut on short notice. Write for prices

MANUFACTURERS OF AND WHOLESALE
DEALERS IN



B. C. WHITE PINE
LUMBER and LATH

Write Us About Our LARCH LUMBER

Factory Lumber
and
Tank Stock

A Specialty

BAYARD, B. C.

BRITISH COLUMBIA LUMBER AND SHINGLE MANUFACTURERS

BLUE & DESCHAMPS

Manufacturers of

Tamarac, Hemlock, Spruce
Fir, Cedar and White Pine

MILL AND OFFICE: ROSSLAND, B. C.

China Creek Lumber Co., Limited

Manufacturers of

Fir, Tamarac and Yellow Pine

WE MAKE LATH

Mill at CHINA CREEK

Office at ROSSLAND, B. C.

The MAYOOK LUMBER COMPANY, Limited

MANUFACTURERS OF

LARCH, PINE AND FIR TIMBER

Head Office: MAYOOK, B. C.

WINNIPEG Office: 445 Main Street

Saw and Planing Mill at MAYOOK, B. C.

CEDAR LUMBER

Manufacturers and Shippers

Cedar, White Pine, Fir
Lumber, Lath, Mouldings, Shingles

Bowman Lumber Co., Ltd.
Revelstoke, B. C.

Mills at { REVELSTOKE, B. C.
COMAPLIX, B. C.



ROSS BROS & CO.

FORMERLY OF WHITEMOUTH, MAN.

SUCCESSORS TO THE ELKMOUTH LUMBER CO.
ELKMOUTH, BRITISH COLUMBIA

Full Lines Kept in

Pine, Fir and B. C. Tamarac

ORDERS RESPECTFULLY SOLICITED

Send for Our Prices

The Ladysmith Lumber Co., Limited

LADYSMITH, B. C.

Manufacturers of

LUMBER, LATH, SHINGLES,
MOULDINGS, ETC.

SPECIALTY: The best Cedar Shingles manufactured on the Coast.

FRESH WATER FIR LATH ALWAYS IN STOCK.

Capacity of Shingle Mill, 100,000 per day of 10 hours.

Correspondence Solicited

THE EAST KOOTENAY LUMBER CO., Limited

Saw and Planing Mills at Ryan, Cranbrook and Jaffray, B. C.

Capacity, 150,000 Feet Per Day

MANUFACTURING

LARCH

PINE and FIR

Lumber, Timber, and all kinds
of Mouldings, also dealers in
Railway Ties, Piles and Poles

Large Stocks of Well Seasoned Dry Material Always on Hand

HEAD OFFICE

CRANBROOK, B. C.

"DEFIANCE"

Wood--Working Machinery

For Manufacturing

HUBS, SPOKES, WHEELS, WAGONS,
CARRIAGES, RIMS, SHAFTS, POLES,
NECK-YOKES, SINGLE TREES, BARREL
HOOPS.

Handles of Every Kind, Insulated Pins, Spools,
Bobbins, Oval Wood Dishes, and General Wood-
Work.

Invented and Built by

THE DEFIANCE MACHINE WORKS,
Defiance, Ohio, U. S. A.

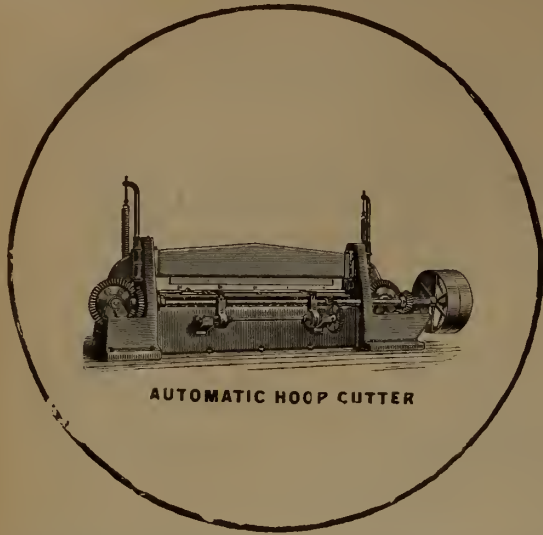

AUTOMATIC HOOP CUTTER



TRIPLE HOOP AND TRUNK SLAT PLANER



The "Alligator" Steam Warping Tugs

SIDE WHEELS OR TWIN SCREWS

The Twin Screws are arranged with flexible joint to
raise up in crossing portage

MANUFACTURED BY

WEST & PEACHEY, - Simcoe, Ont.

Cables carried in stock for renewals

THE E. LONG MANUFACTURING CO., ORILLIA, ONT.

THESE SAW CARRIAGES ARE MADE OF CAST STEEL, AND OPEN 36 TO 54 IN. FROM SAW.

We build Double Edgers, Steam Feeds, Log Jacks, Live Rolls, Trimmers, Slab Slashers, Steam Niggers.

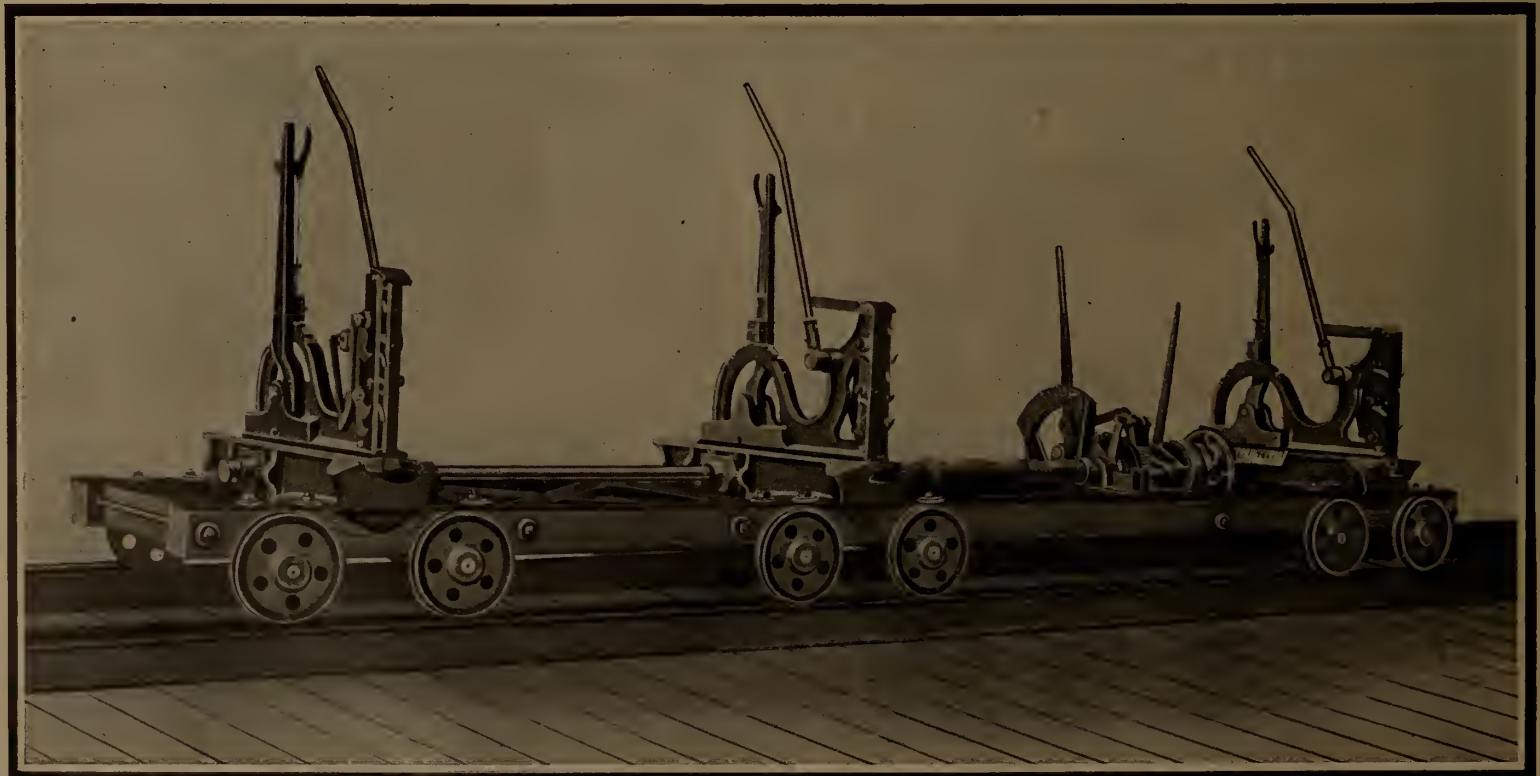

COMPLETE LINE OF SAW AND SHINGLE MILL MACHINERY
WRITE FOR CATALOGUE AND PRICES

FRANK DENTON, K. C. HERBERT L. DUNN
W. MULOCK BOULTBEE.
DENTON, DUNN & BOULTBEE
Barristers, Solicitors, Notaries, etc.
National Trust Chambers. TORONTO

DO YOU USE IT?
BAUGHMAN'S BUYER & SELLER
THE HANDY BOOK FOR LUMBERMEN
Saves half the time and all the mistakes in
figuring Invoices, Estimates and Inventory.
Send for sample copy.
Flexible Cloth \$1.00
Flexible Leather 1.25
Sample Page Free. Address
H. R. H. BAUGHMAN
INDIANAPOLIS, IND, U. S. A

THE NEW
Dominion Saw Gummer
Saw Gummer Cutters of all Descriptions
MANUFACTURED BY
A. T. McLATCHIE, Cardinal, Ont.

For the Cutting Department

CUT MATERIAL
Board or Surface Measure Contents
AT A GLANCE
from the time, labor and brain saving
BOX ESTIMATOR
Sent on trial
JAMES M. LEAVER
Sault Ste. Marie, Mich.

Standard Invaluable

of any Woodworking Plant

John M. Garland, Son & Co.,
WHOLESALE DRY GOODS

OTTAWA, CANADA



It will pay you to buy your
VAN SUPPLIES from us. Some
lumbermen have an idea that
General Dry Goods Houses cannot
furnish them with goods suitable
for their camps. Now, we would
like to impress upon you the fact
that for over a quarter of a century,
WE have made this branch of our
business a specialty and are there-
fore in a position to supply you
with the best material and the best
make, without charging fancy
prices. We would be pleased to
forward samples and price list on
application.

JOHN M. GARLAND, SON & CO.,
Cor. Queen and O'Connor Sts.,
OTTAWA, CANADA

The Manitoba Gypsum Co.

MANUFACTURERS OF LIMITED

HARDWALL PLASTER WOOD FIBRE PLASTER
PLASTER OF PARIS STUCCO ALABASTER
and All Kinds of Gypsum Products

The Only Plaster Co. in Western Canada

Quality of goods superior to any imported article, our mill being equipped with the latest improved machinery.
Dealers are invited to get our quotations before placing orders for Spring requirements

Office: 311 UNION BANK BUILDING, WINNIPEG

D. E. ROBERTS Lately in charge of the Plymouth Plaster Co., at Fort Dodge, Iowa. **WM. MARTIN**
Superintendent of Manufacture General Manager

Get Rid of Your Trouble

with Gears, which are eating up too much of your power, by putting in a **Horizontal Setting** as shown here. This is the **Modern Way** and also the **Economical Way**, for it will save you **Water, Power, Time and Money**. This cut shows a **Globe case** containing a **Triumph Turbine**, with elbow, two pulleys, one of which may be cut off by a clutch, and governor, all mounted on the one steel frame. This setting is self-contained, rigid and durable, and permits a direct belt drive to the machine to be driven.

Our **Triumph Wheels** placed horizontally give from 5 to 10 per cent. better results than any other wheel, owing to their perfect discharge. For light powers with limited water our **Improved Standard Leffel and Vulcan Wheels** have no equals. If you are developing a new power or replacing an old setting, let us figure with you. We can furnish any style of setting for any head or power, and our experience in this line is at your service.

We also build the **Improved Lane Circular Saw Mills** with capacities of from 5 to 50 M. per day, **Shingle Machines** and all **Machinery** for making lumber, lath or shingles.

Our new **Tie Machine** will make 1200 Ties in 10 hours. It's worth investigating.

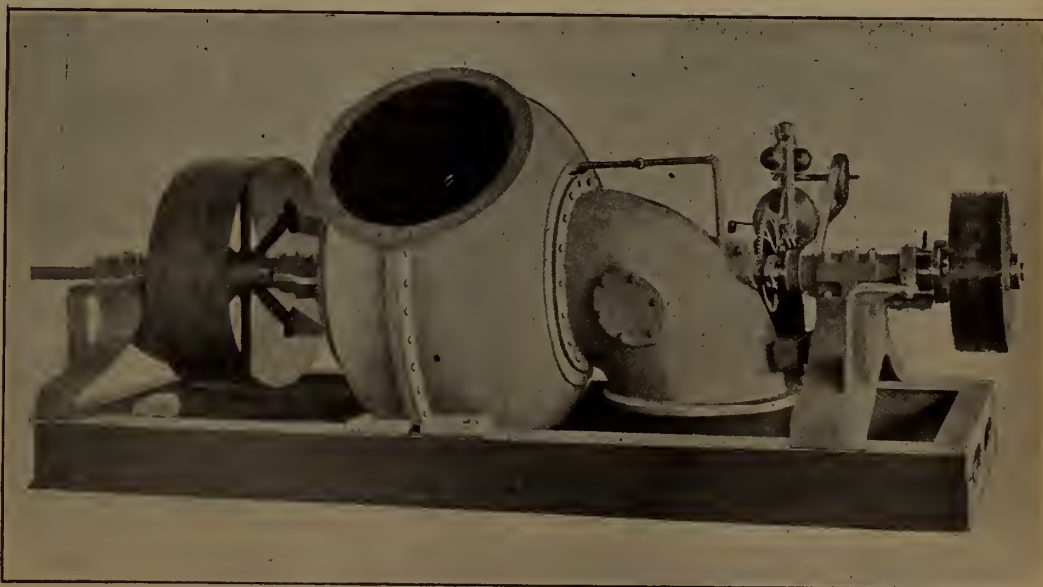

MADISON WILLIAMS

H. E. PLANT, Agent
Cor. Common and Nazareth Streets
Montreal, Que.

Successor to Paxton, Tate & Company
PORT PERRY, ONT.

Manitoba Iron Works
Western Selling Agents
Winnipeg, Man.

... OUR AIM ...

is to impress upon all buyers the importance of
INVESTIGATION

Unsubstantiated statements are worthless
 Profit by the experiences to others

We will give you
 full detail infor-
 mation with a list
 of users

Don't fail to ask
 us for it!

CLEMENT
 54-INCH
 BAND RESAW

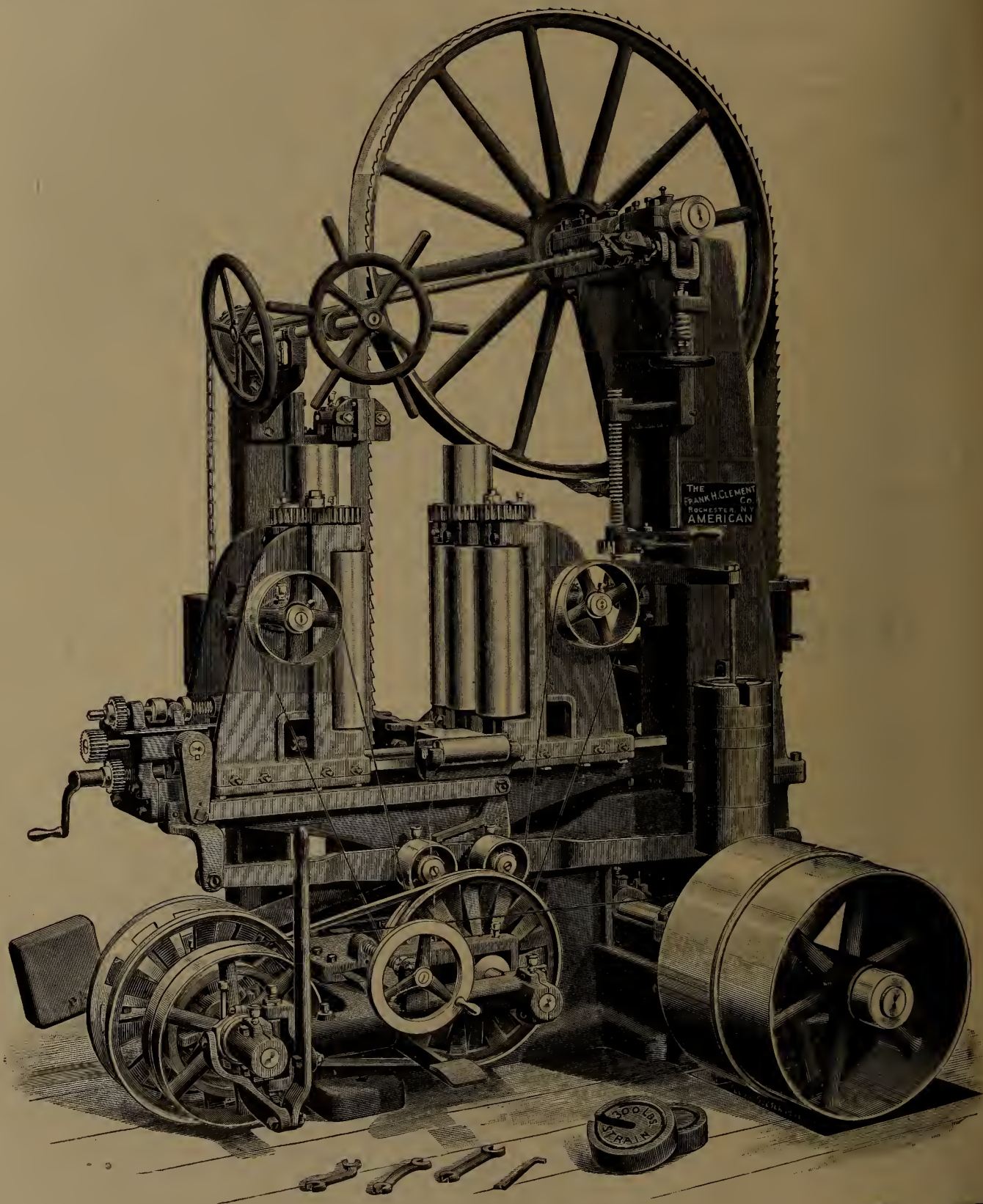

AMERICAN WOOD WORKING MACHINERY CO.

136 Liberty Street . . . NEW YORK

Sales Agent: Canadian Fairbanks Co., MONTREAL



*** THE ***
**MAPLE LEAF
 SAW WORKS**



Shurly &

 Dietrich
 GALT, ONT.

Manufacturers of

- CIRCULAR SAWS
- GANG SAWS
- MILL SAWS
- BAND SAWS
- CROSS-CUT SAWS



Manufacturers of

- HAND SAWS
- BUCK SAWS
- PLASTERING TROWELS
- BUTCHER SAWS
- STRAW KNIVES, &c.



GROUND THIN ON BACK
 Save Labor Save Gumming
 Save Time Save Files

This Saw Stands Without a Rival

AND IS THE
FASTEST CUTTING SAW IN THE WORLD!

Its Superiority consists in its Excellent Temper. It is made of "Razor Steel," which is the finest ever used in the manufacture of Saws. We have the sole control of this steel. It is tempered by our secret process, which process gives a keener cutting edge and a toughness to the steel which no other process can approach.

Maple Leaf Saw Set

MANUFACTURED BY
 SHURLY & DIETRICH, Galt, Ont.

Directions.—Place the set on the point of tooth, as shown in the accompanying cut, and strike a very light blow with a tack hammer. If you require more set, file the tooth with more bevel.
 If you follow directions you cannot make a mistake. Be sure and not strike too hard a blow, and it will set the hardest saw. On receipt of 40 cents we will send one by mail.



We are the only manufacturers in the world who export Saws in large quantities to the United States.

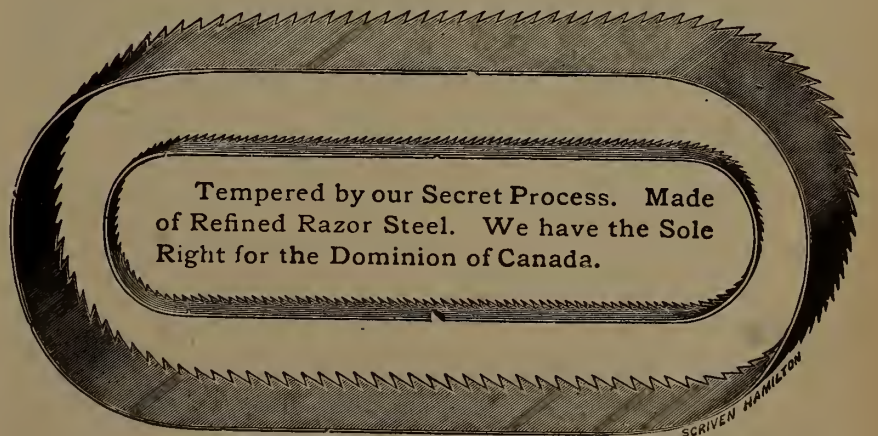

We Manufacture

HIGH GRADE BAND SAWS

Of All Widths and Lengths.

These Saws are made of Refined Swedish Steel imported direct, and tempered by our Secret Process; for Fine Finish and Temper are not excelled.

CLASSIFIED INDEX OF ADVERTISERS

AXES
Dundas Axe Works..... 40

ALLIGATOR TUGS
West & Peachey..... 6

BELTING
Canadian Fairbanks Co..... 3
Dominion Belting Co..... 37
Gutta Percha & Rubber Mfg. Co..... 41
Goodhue & Co., J. L..... 1
McLaren, D. K..... 1
McLaren Belting Co., J. C..... 44
Waterous Engine Works Co..... 37
Wilby, P. H..... 12
Young, J. S..... 1

BABBITT METALS
Syracuse Smelting Works..... 44

BOILERS
Dyment Foundry Co..... 36
John McDougall Caledonian Iron Works 31

DOORS
New Century Refrigerator & Mfg. Co. 10

DRY KILNS
Andrews Co., The A. H..... 43
McEachren Heating & Ventilating Co. 43
Sheldon & Sheldon..... 43
Standard Dry Kiln Co..... 43

ELEVATING AND TRANSMITTING MACHINERY
Perrin & Co., R..... 12

EMERY WHEELS
Hart Corundum Wheel Co., Limited.. 28

ENGINES AND LOGOMOTIVES
Dyment Foundry Co..... 36
Gartshore, John J..... 10
Owen Sound Iron Works..... 41
Robb Engineering Co..... 39

EDGERS
Gordon Hollow Blast Grate Co..... 39

GRATES
Gordon Hollow Blast Grate Co..... 39

LUMBERMEN'S SUPPLIES
Beal Leather Co., R. M..... 32
Barr, Alex..... 12
Capstan Mfg. Co..... 37
Garland Son & Co., John M..... 7
Johnson, A. H..... 39
Park, Blackwell Co..... 40
Rice Lewis & Sons, Limited..... 44
Thompson Mfg. Co..... 44
Tobin, Joshua..... 28
Woods, Limited..... 1

LUMBER AND SHINGLE MANUFACTURERS
Bowman Lumber Co..... 6
Cook & Bro. Lumber Co..... 32
Canadian Pacific Lumber Co..... 22
China Creek Lumber Co..... 5
Crows Nest Pass Lumber Co..... 4
Columbia River Lumber Co..... 4
East Kootenay Lumber Co..... 5
Ferne Lumber Co..... 4
Ladysmith Lumber Co..... 5
Mayook Lumber Co..... 5
North Star Lumber Co..... 4
Ross Bros. & Co..... 5
Staples, Otis..... 4
Yale-Columbia Lumber Co..... 4

LUMBERMEN'S TOOLS
Baldwin, Tuthill & Bolton..... 41
Hay Knife Co., Peter..... 22
Pink, Thomas..... 44

LUMBERMEN'S AGENTS
Friel, H J..... 37
Wright, H J..... 37

MISCELLANEOUS
Alexander Engraving Co..... 31
Bradstreets..... 10
Canadian Office & School Furniture Co. 10
Clyde Iron Works—Log Loaders.....
Denton, Dunn & Boulton, Barristers. 7
Fielding, J. S., Consulting Engineer.. 1
Georgian Bay Engineering Works—
Grinders..... 43
Huther Bros.—Dado Heads..... 44
Lumber Mutual Fire Insurance Co.... 34
Midland Engine Works Co.—Tram
Car Wheels..... 12
Mitskun Co., M.—Car Movers..... 32

Monteith, Nixon & Co.—Trucks.....
Manitoba Gypsum Co.—Plaster..... 7
Spence & Co., R.—Files and Risps... 11
Saw Gummer, A. T. McLatchie..... 7
Sessenwein Bros.—Rails..... 29
Toledo Fire Insurance Co..... 33
Vogel, C. H.—Pulp Mill Engineer.... 30

OILS
Commercial Oil Co..... 37
Canadian Oil Co..... 22
Queen City Oil Co..... 11

PROVISIONS
Eckardt & Co., H.P..... 27

PORTABLE SAW MILLS
Drake, F. J..... 36
Owen Sound Iron Works..... 41

PLANERS AND MATCHERS
Cowan & Co..... 3

PULLEYS
Canadian Fairbanks Co..... 3

PACKING AND PIPE COVERING
Garlock Packing Co..... 12
Purvis Co., E. L..... 37

ROPE
Consumers Cordage Co..... 34
Dominion Wire Rope Co..... 12
Greening Wire Co., B..... 1
Mussen & Co., W. H. C..... 1

ROOFING
Bird & Son, F. W..... 32

RE-SAWS
Cowan & Co..... 3

SAW SWAGES
Hanchett Swage Works..... 29

SAW GAUGES
Specialty Mfg. Co..... 12

STEAM BOILERS
Owen Sound Iron Works..... 41

SAWS
Atkins & Co., E. C..... 38
Burns Saw Co., E. R..... 1
Hoe & Co., R..... 42
Shurley & Dietrich..... 4

SAW MILL MACHINERY
Allis-Chalmers-Bullock..... 3
Gordon Hollow Blast Grate Co..... 39
Hamilton Mfg. Co., Wm..... 2
Jenckes Machine Co..... 38
Kendall, I. N..... 41
Long Mfg. Co..... 7
Lloyd Mfg. Co..... 6
Manitoba Iron Works..... 34
Mowry & Sons, B. R..... 38
Owen Sound Iron Works..... 41
Petrie, H. W..... 1
Payette & Co., P..... 34
Smart-Turner Machine Co..... 44
Waterous Engine Works Co..... 11
Williams, Madison..... 7

SHINGLE MILL MACHINERY
Drake, F. J..... 36
Long Mfg. Co., E..... 7
Owen Sound Iron Works Co..... 41
Williams, Madison..... 7

STOVES
Hall, Adam..... 42

TURBINES
Williams, Madison..... 7

TRIMMERS
Gordon Hollow Blast Grate Co..... 39

WOODWORKING MACHINERY
American Woodworking Machinery
Co.....
Connell & Dengler Machine Co..... 39
Cowan & Co., Limited..... 3
Defiance Machine Works..... 6
Perkins & Co..... 40
Rogers Iron Mfg. Co..... 40
Sherman Co., W. S..... 39
Shimer & Sons, Samuel J..... 40
Waterous Engine Works Co..... 11

The . . .
QUEEN CITY OIL CO.
LIMITED
Head Office: TORONTO.

HIGHEST GRADES OF
Refined Oils
Lubrication Oils

AND ALL
Petroleum
Products



ESTABLISHED 1849.
BRADSTREET'S
Capital and Surplus, \$1,500,000.
Offices Throughout the Civilized World.
Executive Offices:
Nos. 346 and 348 Broadway, New York City, U.S.A.
THE BRADSTREET COMPANY gathers information that reflects the financial condition and the controlling circumstances of every seeker of mercantile credit. Its business may be defined as of the merchants, by the merchants, for the merchants. In procuring, verifying and promulgating information, no effort is spared, and no reasonable expense considered too great, that the results may justify its claim as an authority on all matters affecting commercial affairs and mercantile credit. Its offices and connections have been steadily extended, and it furnishes information concerning mercantile persons throughout the civilized world.
Subscriptions are based on the service furnished, and are available only by reputable wholesale, jobbing and manufacturing concerns, and by responsible and worthy financial, judiciary and business corporations. Specific terms may be obtained by addressing the company or any of its offices. Correspondence invited.
THE BRADSTREET COMPANY.
OFFICES IN CANADA: Halifax N.S. Hamilton, Ont. London Ont.; Montreal, Que.; Ottawa, Ont.; Quebec, Que.; St. John, N. B. Toronto, Ont. Vancouver, B.C.; Winnipeg, Man.
THOS. C. IRVING,
Gen. Man. Western Canada, Toronto

RAILS For Logging Tramways, Switches, Etc.
YARD LOCOMOTIVES New and Second-Hand.
John J. Gartshore
83 Front St. West,
(Opposite Queen's Hotel,) Toronto.

R. SPENCE & CO.
Beech File Works.
HAMILTON, ONT.
FILE AND RASP MANUFACTURERS
AND RE-GUTTERS
A trial order solicited. Write for price list and terms.
C. P. MOORE, PROPRIETOR.

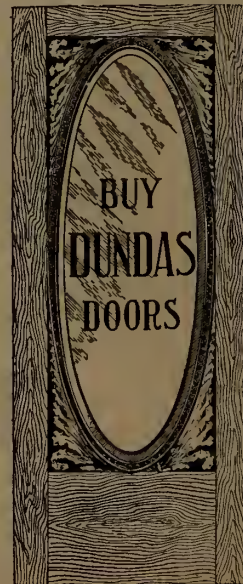

New Century Refrigerator & Manufacturing Co., Limited
Dundas, Ont., Can.

Our Business is Manufacturing
HARDWOOD VENEER . . DOORS
With Built-Up Bodies

These Doors are guaranteed not to warp or twist and are superior in construction and finish to any other Door on the market.

Send for Illustrated Catalogue and Prices.
Special attention given to Architects' Designs of Doors and Trims.

AGENTS WANTED EVERYWHERE.

ADDRESS DOOR DEPARTMENT



17 to 30% SAVED

By Cutting Small Logs with

DOUBLE CUTTING BAND MILL

Instead of with CIRCULAR

This Illustration shows our DOUBLE CUTTING PONY BAND MILL, 6 foot Wheels, Suitable for Portable or Stationary Mills

We Manufacture a Special
Complete Line of

Saw Mill Machinery

Designed Expressly for
Use with the

Pony Band Mill

We Can Supply Anything Necessary
for the Equipment of Any
Size Saw Mill

Send for our new No. 32A Circular



One of the many Double Cutting Band Mills with 8 ft. Band Wheel in Actual Operation

WATEROUS, BRANTFORD, CANADA

TEON BELTING

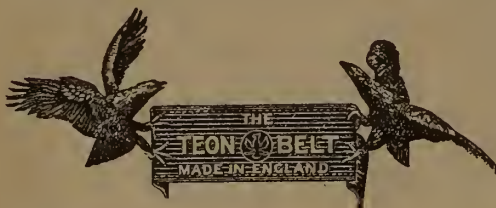

STEAM PFOOF
 WATER " "
 HEAT " "
 OIL " "
 ACID " "
 Stronger and Cheaper than
 Leather.

LEATHER BELTING
 CAPATA BELTING [BALATA TYPE]

CAMELS HAIR BELTING
 LACE LEATHER, ETC.

Special Arrangements for Trial Belts.
 Write for Price Lists and Discounts.

P. H. WILBY, 27 1/2 Front Street East, TORONTO
 Phone Main 1930. SOLE AGENT FOR CANADA.

Our special

Tram Car Wheels



made from a special mixture of Iron,
 are stronger, longer lived, low in
 price and lighter for their strength
 than any other wheel. Write
 for prices and samples of metal.

MIDLAND ENGINE WORKS CO.
 MIDLAND, ONT.

LARGE STOCK CARRIED & CUT TO ANY LENGTH
 BLOCKS, CLIPS, TURNBUCKLES, ETC.

WIRE ROPE

SPECIAL ROPES FOR LUMBERING
 DOMINION WIRE ROPE Co., LTD
 MONTREAL, QUE.

EVERY LUMBERMAN WANTS IT

35 cents buys it

Scribner's Lumber and Log Book

BRIMFUL OF EVERY-DAY
 PRACTICAL INFORMATION

Address :
 THE CANADA LUMBERMAN, Toronto



THE LUMBERMEN'S FRIEND

(De-jardin's Patent)

ALSO

Heavy Runners for Logging Sleighs
 Bent to Order, Poles, Beams, Roll-
 ers, Blocks and other parts on
 hand at all times.

I ALSO MAKE
 Boom Chains
 Logging Chains
 Skiddin Tongs
 Clevis' Heavy
 Neckyokes and
 Whiffletrees

Large
 DUMPING WAGONS
 for Mill Yards a
 Specialty

ALEX. BARR

WRITE FOR PRICES

Manufacturer

Pembroke, Ont.

Detachable Chain Belt

—AND—

CONVEYING

MACHINERY



William R. Perrin & Company
 Limited

TORONTO, CANADA.

WOODWORKERS SAY
 "The convenience to the Sawyer and
 the saving in lumber make the
STANDARD AUTOMATIC SAW GUAGE
 an article of much merit."
 WRITE TO
 SPECIALTY MFG. CO.
 DETROIT
 MICH.



Garlock Packing Co.

HAMILTON - - - CANADA

—SOLE MANUFACTURERS OF—



GARLOCK'S PACKINGS

PATENTED

Asbestos and Mineral Wool Pipe and Boiler
 Coverings, Engineers' Supplies in General



THE CANADA LUMBERMAN AND WOOD-WORKER

VOLUME XXV.
NUMBER 8.

TORONTO, MONTREAL — SEPTEMBER, 1905 — WINNIPEG, VANCOUVER

TERMS, \$1.00 PER YEAR
Single Copies, 10 Cents

MR. ANDREW McCORMICK.

One of the most interesting figures in Ottawa district lumber circles is Mr. Andrew McCormick, one of the "old guard." For over half a century he has been identified with the business, and he was well established in it before the first plank was thrown off a saw at the Chaudiere.

Although a Scotchman by birth, Mr. McCormick prides himself on being a Canadian. Born in Ayrshire, Scotland, seventy years ago, he came to Canada at the age of seven. He came across the blue Atlantic in one of the old type sailing vessels, steam then being but a dream of the future. Although he was but a "sapling" at the time, Mr. McCormick remembers the trip well. The ship was not a regular cargo carrying vessel, but was chartered by a party of sturdy Scotchmen, including McCormick, sr., and fitted up in compartments, one for each family.

On February 11th, 1843, Mr. McCormick, then a lad of fourteen, entered on his long and successful lumbering career. He left Ottawa—then Bytown—on that date, his destination being the Dumoine river. The young lumberman was then in the employ of the late Joseph Aumond, one of the earliest operators of the Ottawa district. Mr. McCormick worked in his early days as clerk. From the Dumoine country the square timber for the British market was driven down the river of that name sixty miles to the Ottawa and down the latter stream ten miles to the Des Joachims boom, where it was made into rafts for movement to Quebec City. Towing was not heard of in those days, and the rafts had to be propelled by huge oars, hewn into shape by the deft axe handlers.

Mr. McCormick remained in Mr. Aumond's employ twelve years, at the end of which time he was in full charge of several shanties on the limits. In the early days it was also customary to cut deals and float them down in rafts to Quebec for export. The manufacture of square timber was not one of the lost arts in those days, and the husky axe handlers were able to manufacture twice as much as do their successors to-day.

There is an erroneous impression that the lumber operators have pushed hundreds of miles past the mark set in the early days, but even then, according to Mr. McCormick, red pine was manufactured in the Temiskaming district. However, operations were then in full swing on the Rideau, Blanche, Nation, De Grace and other streams along the Ottawa which are now lined with farms.

The leading operators when Mr. McCormick

entered the field were Gilmour & Company, Jos. Aumond and John Egan, father of Mr. H. K. Egan, of the Hawkesbury Lumber Company. Besides their own camps these firms contracted each with thirty or forty jobbers.

Railroads were not at the command of the operations in the olden days, and the supplies had to be "teamed" up from Ottawa to Aylmer by road, and from Aylmer on by the ice bound river.

When he started in business for himself Mr. McCormick operated first along the Mattawa



MR. ANDREW McCORMICK, Ottawa.

river and afterwards along the Schyan, Otter Creek and the Dumoine river. Later on he did some lumbering in the Gatineau district and also conducted a mill at Sudbury still more recently. At present Mr. McCormick holds extensive limits near the Height of Land which will be served by the new line of railway, the Grand Trunk Pacific.

THE ST. JOHN RIVER TROUBLE.

The application of Attorney-General Pugsley, of New Brunswick, for an injunction to compel the St. John River Lumber Company to remove its piers and booms from the Canadian waters of the St. John river, near Van Buren, was reached in Equity Court before Judge Barker at St. John, N. B., on August 15th, having been postponed from July 5. The first part of the session of the court was taken up with arguments regarding procedure. The attorney-general in opening stated that he would apply later for an order for a viva voce examination of the company's deponents who

he understood had made affidavits declaring the booms necessary to the operations of the company.

The court suggested that this practically meant a hearing and that it would be so well to bring the case to a hearing at once, rather than through the proposed procedure. Mr. Pugsley outlined his contention that the company's sheer boom caught all the logs coming down river and carried them into its sorting boom and that this constituted an obstruction to navigation. H. A. Powell, K. C., of Sackville, counsel for the lumber company, declared that the sheer boom was a necessity because in its absence all the logs would go down river to Fredericton, and the company would be put out of business. Mr. Pugsley interjected that the company could bring down its logs in square rafts. At this point adjournment was taken without the Court's suggestion having been accepted.

The afternoon proceedings began with the reading of the information prepared by Attorney General Pugsley, which included a statement by John E. Moore, a St. John lumberman. Mr. Pugsley contended that the work of the company is violating the Ashburton treaty and made formal application for injunction to prevent the company placing such work and to compel them to remove the boom from Canadian territory.

An affidavit by J. D. Colwell, a St. John lumberman, was also submitted supporting Mr. Pugsley's case. For the St. John Lumber Company, H. A. Powell, K. C., submitted affidavits from A. W. Brown, manager of the company; J. W. Parker, treasurer; J. Poirier, foreman at the sorting boom; R. J. Potts and Holmes Morris, lumbermen. The information was answered in detail that the works were not in the main channel and not an obstruction; that there was opportunity for passage of the river, that the works are of the kind ordinarily employed but better, and are a necessity.

Brief arguments for and against the injunction were heard. Mr. Powell held that Attorney General Pugsley was not the proper one to bring up this matter, but it should be the Dominion Minister of Justice. Judge Barker said there did not seem to be any great necessity for it, but he would like to see some one get a mandatory injunction just for experiment sake. He fixed the third Tuesday in September as the time and St. John as the place for continuation of the case.

It is rumored that the Rathbun Company, of Deseronto, have acquired the old Gilmour saw mill at Trenton, Ont., and will remodel it in the near future.

FIRE INSURANCE FOR THE LUMBER INDUSTRY; AGITATION AGAINST EXCESSIVE RATES

The publishers of the CANADA LUMBERMAN were requested by a prominent member of the lumber trade to secure the opinions of some of the leading mill men on the advisability of forming a mutual insurance company to carry saw mill and lumber risks. The replies received are given below, numbers being substituted for the firm names:

No. 1: We think a company to insure lumber and saw mills alone, if properly managed, should be a success at much lower rates than the tariff rates.

Over experience with Lumber Mutuals in the United States has been quite satisfactory. Some ask lower rates than 10 per cent. and some the same rates as the board companies and pay us a refund of 15 to 25 per cent. of the premium; and we understand an experiment tried by some fifty members of the National Wholesale Lumber Dealers Association of New York of paying premiums on \$5,000 into a trust for five years resulted in actual fire loss of about 50 per cent. We think the insurance companies in general do not classify their risks enough and raise rates all round, whereas perhaps the business most affected is already paying its full share.

No. 2: We are entirely in sympathy with the spirit of dissatisfaction which exists with regard to insurance on saw-mills and lumber yards.

The base rate of \$4.25 on saw-mills, with addition, which makes most mills from 5 to 6 per cent., is unreasonable, and consideration is not given to the character of the mill, but it is simply an extortionate arbitrary rate. In many cases, we admit, there is a great difference in saw-mills, but insurers should recollect that the bulk of the mills, whose supply of logs are taken from the water, only run half the year, and pay insurance for the full year; then, a modern fully equipped mill is generally much better looked after than the old fashioned mills where the machinery and cost of construction is less in amount.

As regards yards—it is just a question with the insurance companies of how much revenue they can get out of the business. Very little regard or allowance is made for the improvements made and the fire protection supplied for the yards.

We, ourselves, do not think it practical to form a Lumbermen's Insurance Company on the basis of the organization required by either the Provincial or Dominion Government. What is practical, and what we ourselves use, is the system of Lloyds, where lumbermen are the particular underwriters, each carrying a specific amount of a policy. There are several in the United States, and the extension of those to Canada is very much to be desired. There are forty or fifty lumber concerns which could easily join in assisting one another to carry their insurance risk at a minimum cost. We certainly are using the United States Lumbermen's, Lloyd's insurance ourselves.

No. 3: We feel that we are paying exorbitant rates for insurance and I have been laboring with the Canadian Underwriters Association for four years, trying to get a reduction in our rates, but have been unable to do so. For example, on lumber we are paying \$3.50 without a co-insurance clause, and our lumber is piled out over the water on a tramway on piling. Now then, we carry insurance at Port Huron, Mich., at a much lower rate, with the Board companies, and the risk is much more hazardous than our risk here. I am quite satisfied that the insurance companies are making more money out of the lumber business than they are out of any other business. I am of the opinion that it would be a good plan for the lumbermen to have a meeting at some point and discuss the question. I am satisfied that if the Canadian lumbermen would organize an insurance company that it would be profitable to them.

No. 4: Regarding the question of insurance on saw-mills and lumber yards, so far as we are concerned we

have, on the whole, reasonably satisfactory rates on our mills and yards. Certain of them we consider we are paying too much money on, but others are lower, so that the general average is reasonably satisfactory.

We are doubtful as to the advisability of the Canadian lumbermen organizing an insurance company to carry their own risks. The amount of insurance on lumber mills, etc., is very large, and it would need a large amount of capital to make the lumbermen feel perfectly satisfied that losses, no matter how large, would in every case be paid. We feel that this large amount of capital would be required, as the probability of re-insuring, owing to the high rates charged by the tariff companies, would seem to preclude such method of handling the business.

No. 5: There is no doubt that an organization of the Canadian lumbermen to carry lumber risks exclusively would prove quite profitable in the end, as we do know of a number of similar companies in the United States, in Ohio, Pennsylvania, New York and Massachusetts, who handle this class of business with very satisfactory results.

No. 6: The insurance question is a serious problem to the millmen in this district, as we were paying on one of our mills up to the present year 7 per cent., but the underwriters have lowered this to 6 per cent. We are about to install a tank in the vicinity of our mill holding about 30,000 gallons of water that will give us ample water supply at an elevation of some 40 feet above the roof of the mill, and we therefore will not consider the carrying of any insurance at all on the mill plant.

Regarding our other mill, might state that we carry no insurance at all on mill or stock as the rate there is $7\frac{1}{4}$ per cent., which we consider is very unjust. We think it would be a proposition for the Canadian lumbermen to consider the organization of an insurance company of their own.

No. 7: You state that there exists in some quarters a feeling of dissatisfaction with the insurance afforded by the present companies, but as far as we are concerned we have no reason to complain of any injustice. We, of course, as do most people who carry insurance, naturally think that our rates are too high, and we are of the opinion that risks might be improved and rates thereby lowered if a thorough system of inspection of risks was carried out by men fully qualified to do the work and to give advice to insurers as to alterations or other such necessary work whereby the risk would be improved. This, we feel satisfied, would be in the interest both of the insurer and the insured.

Under the present arrangements the Canadian Fire Underwriters' Association inspector visits us once in probably two or three years and makes a report to the Association, whereas we think he ought to make a visit twice a year, or at least once a year. The inspector who visited us last we considered a competent man and we only wish we could say the same of the inspectors of the various insurance companies who favor us with a visit once or twice during the summer months. The majority of these inspectors are really not practical men and therefore make all kinds of ridiculous suggestions, as in the following instance: The water in the lake had risen so much as to be two inches above the floor of our mill. The foreman, in order to make walking good, put down six inches of sawdust. In a day or two a live young insurance inspector happened along and promptly informed the mill foreman that that was a dangerous proceeding, that the sawdust would be sure to heat and set the mill on fire.

With regard to the organization of a lumbermen's insurance company to carry lumber risks exclusively. We have no doubt that this could be successfully carried out and it would probably give relief to a certain extent, as we understand has been the case in the United States, but after all it would only be a drop in the bucket. How much, for instance, would such an

association write upon a lumber stock of say \$200,000—probably not more than \$20,000 to \$25,000 at the outside, so that the balance would have to be placed with the regular companies at their own rates and on their own conditions.

All the regular companies claim that lumber risks have lost them a great deal of money in Canada, and, although two years ago rates were increased 50 per cent., it is questionable if they will be reduced in the near future, as the companies have again had heavy losses this year.

We are strongly of the opinion that rigid inspection on the part of the insurance companies and more care as to the condition of risks and fire appliances by the insured would tend greatly towards a reduction in rates.

No. 8: Re insurance on lumber risks, I am decidedly of the opinion that our industry is unfairly treated by the Board companies. We are paying an average of 50 per cent. more than similar risks are charged on the American side. Wherever statistics are available they prove that lumber insurance is very profitable to the company. The agents on the Pacific Coast receive a commission of 20 per cent. on the premiums, and I think this is too much. It would, in my opinion, be a profitable venture to establish a lumber insurance company; the capital required need not be very large, as at first a large proportion of the risks could be reinsured and still leave the company a good margin. The agents' commission could be saved in most cases.

No. 9: In reference to question of insurance on saw mills and lumber yards, we have to say that we find the rates very high indeed. We have to carry a very large line, and just now it runs to over \$200,000. Where during the sawing season stocks are very large and we have to carry lines on sawn lumber only for three to six months, the rates the Board companies charge for short term risks are altogether too much, we think.

In the United States the large lumbermen have got together and established mutual companies, and from statements showing results that have been put before us we consider they have been most successful. We think the same plan could be worked out to advantage in Canada, but it would necessitate considerable work, we think, before such an organization could be put on a proper basis.

No. 10: Without a much more intimate knowledge of the business than we possess, we are unable to express an opinion as to the advisability of lumbermen conducting an insurance company which would be confined to the lumber trade risks only, and although we know the present Board rates to be most onerous, it is difficult to criticize them intelligently when we are so much in the dark as to premium receipts, expenses and average losses applicable to the lumber trade.

There are, however, some things that seem to us wrong; for instance, we are informed that the underwriters have plans made of their standard saw mill, shingle mill and yard. These are fairy-like productions, and although there are a good many mills and yards in this world, we doubt if any one has yet reached the standard. A rate is then fixed to this picture mill, and every real live working mill that wants insurance has to pay extra for each item that it may lack as compared with the standard, and by the time the inspector has finished his job we begin to wonder if we have any mill at all.

We at one time paid 5 per cent. for insurance, then with a much better plant we paid 8.9 per cent. The increase was so great that it showed bad business somewhere, either the old rate (standing for years) was too low or the new one unjustly high.

We are inclined to think the average of loss is greatly increased owing to the class of risk accepted. Many mills, owing to various circumstances, should not be accepted at less than 100 per cent. Moral risks should receive closer attention and legitimate losses would be smaller.

CONSERVATIVE CUTTING OF TIMBER.*

By E. STEWART,
Superintendent Dominion Forestry Department.

Would it be practicable for the owners of Canadian timber limits to practice conservative cutting?

I have asked a question here which cannot be correctly answered by "yes" or "no."

It may, however, be safely said that it would be as impracticable for the lumbermen of Canada, as a whole, to adopt the intensive systems of Germany and other European countries, admirable as they are there, as it would be for us to introduce all the timber trees of that country and expect them to flourish under the changed conditions prevailing here. On the other hand, I think the day has arrived when improved methods would be practicable and profitable in very many of our white pine limits.

In the few remarks I make to-day I wish to deal with this question very briefly, not as a forester desiring to see forestry practiced for the benefit of the whole community; for the conservation of the water supply and the enormous advantages which the perpetuation of this supply will render, in the future, for motive power; nor do I wish to appeal to you to consider a timber supply for future generations. These considerations we will leave entirely aside, and simply look at the question as business men, owning property, and desiring to make the most possible out of it.

In the first place let me ask you to take a pine tree, say eleven inches at the stump, growing on a limit two or three hundred miles from the mill here in Ottawa. That tree will perhaps make two twelve foot logs of average diameter of nine inches. According to Doyle's rule that tree will yield 38 feet board measure of lumber, principally sap.

The cost of handling these small logs from the time they leave the dump till they pass through the saws is very nearly equal to that of logs two or three times their size, not to say anything of the number of them that sink on their way down the streams. Does it pay after these poles have reached one of your large mills, to keep the large number of men then employed waiting while these small logs are going through the saws, especially when the product is not valuable?

But provided there is a small margin of profit, the question I wish to bring before you is whether it pays best to cut such timber or to allow it to stand till the yield will be say five times as much and the product of a much better quality, not to say anything of the increased price of the product, which with some fluctuations is constantly increasing and will continue to increase.

I am quite aware that there are many things to be taken into account before it can be decided whether it will pay to reserve the smaller timber for future use and maintain a constant supply by rotation cuttings.

This is a matter for investigating by the owner. I apprehend that on some limits this practice could be put into immediate operation, to the great advantage of the owner. In

other cases where there is very little young timber, the reverse would be the case. What I would do if I owned a limit on which there was a mixed stand of pine of all ages, as is usually the case, would be to have a careful examination of it made, giving an approximate estimate of all the pine down to, say, twelve inches in diameter at the stump, and of the quantities below that size, specifying the number of trees at from ten to twelve inches, from ten to eight inches, from eight to six inches, and from six to four inches, and all under that size, with a stem analysis to ascertain the rate of growth per annum. By this means it would simply be a matter of calculation whether I should cut such a limit close, or cut down only to ten or twelve inches at the stump, and taking care to destroy as little as possible of the younger ones.

Barring one factor, viz., forest fires, in your calculation, no surer basis for calculation can exist. You have as one factor annual growth definitely ascertained, another factor would be the present value of this small timber, if marketed at the present time, and the whole question resolves itself into this problem—will the value of the increment of growth exceed the compound interest on the value of this sapling stock. But in favor of the conservative method we should also not forget that interest is declining in our new country while the value of stumpage is increasing.

There is, however, another matter which should not be lost sight of in endeavoring to foster the young growth.

In removing the large pines we allow more light into the forest, which will be followed by a faster growth of the young trees that have suffered from too great shade, but these large pines do not cast near as much shade as the broad leafed trees that usually grow mixed among the pines, and in the examination to which I have referred it would be well to have those doing the greatest injury in this way to the young pines, marked, and where possible, removed.

In this work of survey or examination of the limit and marking of the timber it is quite unnecessary to mark every pine that is to be immediately cut. With intelligent men, instruction to cut nothing under a certain diameter should be sufficient.

The lumbermen now conduct their affairs with great attention to details. They know the cost of logging, driving and sorting of logs, milling, piling, shipping, &c., to the minutest detail, but it seems to me that they should commence one step farther back, and in their profit and loss account be able to state the value of the timber on their limits, not only that which is immediately merchantable, but that crop that is constantly growing and on which they can rely with the greatest certainty if proper care is taken to prevent its destruction by fire. The farmer values his growing crop, but a grain crop is liable to be destroyed by rain or by the lack of it, by rust and other destructive agencies, which seldom affect the growing pine.

High as stumpage is now, when the conditions of the increased use of timber is taken into account, and the decrease in the supply,

that it will continue to greatly increase in the future is inevitable.

It was thought by many that with the increased use of iron, brick, stone and cement in structural works, that the demand for timber would decrease, but statistics not only show an aggregate but a per capita increase of the use of wood, in recent years. When we consider this and then take a survey of the visible supply in the Northern Hemisphere, we cannot but regard the warnings of a timber famine as proclaimed by the ablest foresters of the present day, as well founded.

M. Milard, in a recent work entitled "The Insufficiency of the World's Supply of Timber," says:—

"There are but few countries in the North Temperate zone, at present, able to supply large quantities of timber. Five are in Europe, namely, Austria, Hungary, Sweden, Norway, Finland and Russia; two are in North America, viz., Canada and the United States. It has been shown that the available surplus of Austria, Hungary, Russia and the United States is seriously threatened by increase of population and by industrial development, and that of Norway by the abuse of the axe. There remain only three sources of supply in which confidence can be placed, for yet a little while; these are Sweden, Finland and Canada. They are absolutely and hopelessly insufficient. If Sweden, Finland and Canada were to attempt to supply all the countries, which reach out their hands for timber, their normal production and their forests, too, would be disposed of completely in a very short time, revenue and capital alike." He concludes with the remark that a timber famine is thus within sight.

Considering all these facts, it seems to me certain that not the least valuable, of many limits, is the younger growth, which at present, as I have endeavored to show clearly, does not pay the cost of cutting, and that the owners of timber, especially of white pine, would only be acting with the foresight they show in other matters connected with their business if they gave greater attention to this matter than heretofore. The time has arrived when the man who directs the lumbermen's operations in the woods should have, in addition to his practical knowledge of how to cut and take out logs to the best advantage, also some knowledge of the tree itself; the manner or rate of its growth and how to cut other timber so as to foster that growth. In other words, he should be a forester, as well as a practical log man, and it is fortunate that many young men, most of whom have been brought up in our rural districts, are now studying forestry in the colleges of the United States and spending their vacations in our lumber woods, studying the practical part of the business; and I would strongly advise our lumbermen to avail themselves of the services of these young men, rather than import professionals from Europe, who are necessarily less familiar with conditions.

A word to the reader: Send us a contribution for the October number. Your experience in some particular instance is certain to be interesting to somebody else.

*Prepared for the Midsummer Meeting of the National Wholesale Lumber Dealers' Association, Ottawa, August 16-18, 1905.

MESASURING HEIGHT OF TREES.

The Southern Lumber and Box Company asked the Southern Lumberman for a cheap, practical and accurate device for measuring the height of standing timber, and was given the following answer:

We are under the impression that there are on the market several devices for measuring the height of standing trees, but in the limited time we have had, we have been unable to find the names and addresses of the manufacturers. We are under the impression that the Scientific American, New York, N. Y., some time ago illustrated a rather elaborate and apparently rather costly device for doing this work. An ordinary mechanic could make at small expense a device that, in our judgment, would serve every practical purpose. We print herewith a crude sketch showing how such a height-measurer might be constructed. "G" is an upright on which the device rests and is supported by two or more extensible legs, so that the device can be set and leveled as a sort of tripod. The height of this upright should be great enough to bring the horizontal bar "A" even with the eye of man of average height. The upper part of this upright (marked "B" in the accompanying drawing) is marked and lettered as a scale showing elevation to bar "C"—the figures on this scale indicating the height of point "sighted" on tree—the sighting, of course, being done by the eye and along the upper part of the bar "C", the eye of the "sighter" being applied at "B". Of course, the scale on the upright "B" would have to be computed from actual experiments, every mark on the scale meaning so many feet on the tree "sighted" from a certain distance. In view of the fact that it is not

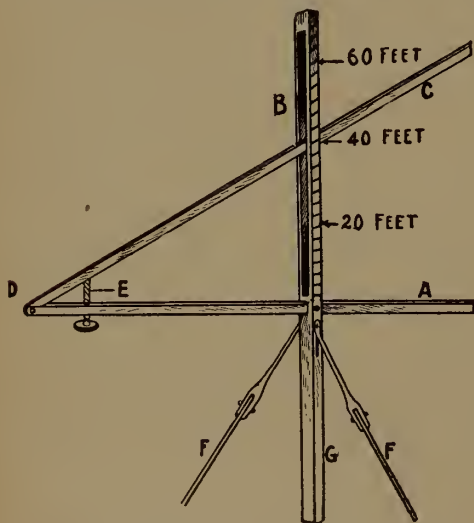

DEVICE FOR MEASURING HEIGHT OF TREES.

always possible to "sight" the tree from the same distance, this upright "B" might have a scale on all four of its sides—one side computed for a distance of 50 feet from the tree, the other 100 feet, still another 75 feet and the fourth side 25 feet. Screw "E" enables the man who is doing the "sighting" to very easily elevate or depress the rod "C" without removing his eye from the "sight". This screw would fix the position of the rod "C" when the "sight" is complete, and the operator would only have to look around at the figures on his scale to obtain the height from the ground to the point from which he "sighted." If the scale rod "B" is made four-sided, as we

have suggested, of course the "sight" bar "C" would have to work up and down in a slot to secure accuracy. This device would have to be planted on the ground absolutely level. To secure this the horizontal rod "A" should contain a spirit level. For rough work, however, a sufficiently accurate level could probably be obtained merely by having attached to the upright "G-B" plumb-bob. It is evident that if the machine is made of the height we have suggested—that of the average man, in order to prevent the operator from having to assume a crouching position in "sighting"—allowance will have to be made for this height. In other words, the operator should take a preliminary "sight" along the upper surface of the horizontal "A" and have an assistant to mark his "sight" point on the trunk of a tree. In nearly every case, this point would be three or four feet above the height of ordinary stumpage, and this distance should, of course, be added to the "sighted" height of the tree. Our little diagram is very crude, and we fear our description is even cruder. Such a device as we describe, however, can be very easily and very cheaply made, and for ordinary commercial purposes, it is sufficiently accurate. We assume that our inquirer is not interested in ascertaining the exact height of a tree to the fraction of an inch, but merely desires for commercial reasons to obtain with reasonable accuracy the length of the "commercial" body or bole of the tree. In short, we assume that he is endeavoring to get at the height of standing timber to be purchased for saw mill purposes.

AN UNUSUAL RESAW DRIVE.

Herewith is presented a sketch of a difficulty drive to a band resaw that has some features not ordinarily found.

The machine is on the floor, almost directly under the line shaft, and in between two other machines, with not more than a foot between the nearest points of either machine. It will be seen, by referring to the dash line, that if the belt had been run with a quarter twist from the driven pulley to the drive on the line shaft, this belt would have come in contact with half the surface of the upper wheel of the machine, hence the need of the idler, which, in this case, was made from a relic rescued from the scrapheap, an old saw mandrel pulley 24x12 inches. To carry this pulley, framing was hung from the mill frame, and made of 6x8 inch, galvanized and heavily bolted, as this pulley had to carry the full working strain of the saw, being on the drive side of the belt.

As is usual in fitting up old stuff, the pulley was bored too large for the shaft I wanted to use, and the first difficulty came in the blacksmith shop, from the smith saying he could not forge iron large enough to make the shaft. My boxes were for 3-inch shafting, and the bore of the pulley was 4½ inch, and the only piece of iron around the place near the right size was an old car axle. As it was in a pair of broken wheels, the job of getting it was too big, so we had to look elsewhere. The fact of the matter was, that we were in a place where we had to "root hog or die," and we came as near making something of nothing as is

ordinarily done. From the remains of an old dredge boat, we got a piece of 3-inch shafting, cut off the required length with a hack saw, and then took this piece to the shop, got a center and trued it up.

We then got a wrought collar from a log loader and had it turned for a bushing, leaving it ⅛-inch large and 1-32-inch small in the bore for a shrinking fit. This bushing was shrunk on the shaft in the center for the pulley to slip over, and then turned off to fit the pulley and

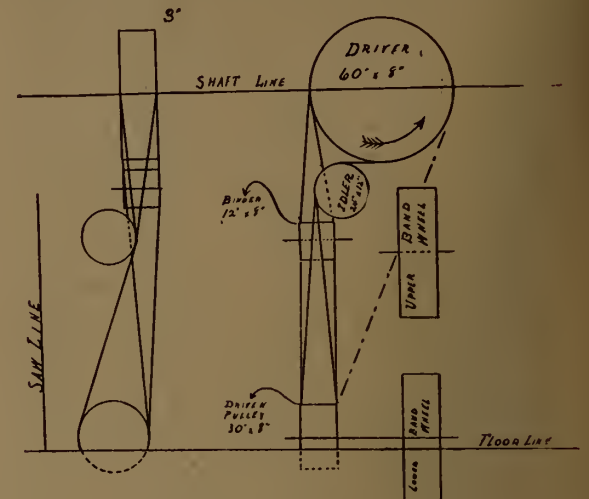

AN UNUSUAL RESAW DRIVE.

for a good balance, for this was a fast-running pulley and had to be carefully balanced to prevent shaking everything loose on the framing. At this point in the work, the machinist got into a difficulty that nearly spoiled all our work, through a little carelessness.

When the piece of shafting was first put in the lathe, a center was made for it, and it was straightened up on this center, one end having a center in it. After the collar was shrunk on it, the machinist cut it off to length before turning the collar to fit the pulley, and then failed in his efforts to get another center true with the shaft. This should have been done either before turning off the shaft in the first place, or else the collar should have been turned off before the shaft was cut off, and this would have left it in a bad condition for turning, if, at any future time, it was necessary to put it in the lathe for truing up. As I was insistent upon a perfect job, a jig had to be turned for the end at the tail-stock, and the center that was perfect was used on the head-stock. Our friend, the machinist, did not like this infringement of his prerogative, but one has to be insistent sometimes to get work done properly.

The necessity for this careful work will be apparent when it is stated that the 60-inch driver was running at 300 revolutions a minute, the idler thus running 750 revolutions a minute, a fast speed for so heavy a pulley up on a frame overhead and nearly four feet from the nearest solid bearing. But it was finally finished in good shape, and ran without any trouble.

The binder pulley, 12x8 inches, was made from a loose pulley off one of the machines, that had been set to run with a swinging tightener, and this pulley was mounted on a frame with provision for moving to take up the slack of the belt on the delivery side, being fastened in position when the belt was sufficiently tight. Luckily, this loose pulley was of a

good type, with a large oil reservoir in the hub, and, as it ran 1,500 a minute, it will be seen, in this case, too, that extreme care was needed to insure a good fit and a good support for the frame. This was put in, and no trouble was experienced with this pulley for nearly a year, when, one day, without warning of any kind, the shaft was forced to one side from its clamps, and the pulley came to the floor with a crash, striking the spot from which the writer had just moved while making some adjustment to the tilt of the upper wheel. The pulley was demolished, and the belt got rubbed a little, but in half an hour we were running again with another old pulley in place.

This old pulley was a plain, cast iron hub, and, as I foresaw some trouble for the proper means of oiling, I had a groove cut in the shaft half its length and a half-inch deep, into which oil was dropped from a cup at one side, the capillary attraction keeping the pulley well oiled as long as the cup was not neglected.

There is one poor feature about this resaw rig that should have been avoided, and that is, the machine must run all the time the mill is running, or the belt must be taken off. As the sawing was rather intermittent, this did not work any hardship, but if it had been in regular use, a friction clutch pulley would have been the logical remedy. This machine was intended to be driven from under the floor, and that would have been the proper position for the drive shaft, but the owners of the mill were set against any proposition of that kind at the starting of the mill, though an after experience showed that it would have been, by all means, the cheapest in the end. The little saving on the lower framing does not compensate for the costly frame and the longer belts and increased cost of maintenance of the overhead shaft.

This method of driving a band resaw is suggested from the fact that the work of the band is at right angles with the line shaft and necessitates a bevel gear, a mule stand or a quarter turn belt to drive the machine. I do not remember seeing more than one band resaw set to drive with a tightener direct from the line shaft, and the work for this saw was at the end of the mill and fed out into a shed, where it was not in the road of the other machines, but was handy to the cut-off saws in the next building. This machine could be started or stopped by means of a small rope, handy to the sawyer, and was the handiest rig yet seen for this purpose, but the saw has to be placed where the work is wanted, in many cases. Then, we have to deal with just such problems as are herein illustrated.

One more feature of this machine deserves notice. It is, rather, merely one of the auxiliaries of the machine, and is a departure from the usual rigging used to shift the guide to the saw. The guides on this machine were rather stiff and hard to move rapidly, but, as all parts of a machine become worn all too soon, it was deemed best to leave it this way, and provide better means of moving the guide than the one sent with the machine. There was the usual lever arm, and a point at which to attach a pole running back over the saw-

yer's head, the movement of which, in a horizontal direction, would move the guide up or down, as required. This was too weak, and, if one board following another varied much in the width, it was necessary to move the guide up before entering the board or the end of the board was very apt to strike the guide before it could be raised out of the way. To remedy this, the pole and its rigging were taken out and a stationary pole of 2 x 4 inches was fastened higher up and out of the way, and at each end of this pole an eye bolt was placed, to which were attached a treble block with 3/8-inch cotton rope, the double blocks to each of these treble blocks being attached to the arm of the lever to move the guide. This arrangement gave a powerful leverage on the guide lever, and the least force moved the guide up or down rapidly and easily. The guide could be jerked up out of the way from a 4-inch strip to a 12-inch board, even when running on the fast speed. The other and prominent feature of this arrangement was that it removed something that was forever knocking off tall men's hats and that had given the writer many a bump on the head. The changing of that part of the saw was a matter of self-protection, as well as a convenience to the sawyer.—Packages.

BURNING SAWDUST.

Mr. S. J. Smith contributes to Power the accompanying plan for burning sawdust. He says:

The principles and methods used in burning

ignited and the walls heated up, green sawdust will burn furiously. The entire surface of the piles of sawdust will be covered with one solid mass of flame and when seen through a peep-hole in the rear wall the combustion chamber will be filled with fire and the flames will often reach to the rear end of the boiler. I have often burned sawdust in this manner taken from green spruce logs which had lain in the water for a year, with excellent results.

A curious phenomenon was often noticed, and that was a mass of balls of fire about the size of marbles and of a deep purple color, which came over the bridge wall and fell to the bottom of the rear pit.

The fireman regulated the supply of sawdust by means of slides in the chutes, but if the chutes become filled with sawdust no harm would be done, as it would run down and cover the grates as fast as it burned away.

We never used a fire-bar when making steam, but simply filled it up and let it burn. When banking the fire at night we would fill the furnace well up to the top, level it off, close all the doors and the damper and let it alone. In the morning a great mass of fire would be found and steam would be up ready for business in short order.

Mr. F. W. Downs says on the same subject :

For burning sawdust or shavings with economy, it is necessary to construct a Dutch oven and feed from a round hole in the top. If the feed hole is made square it will warp

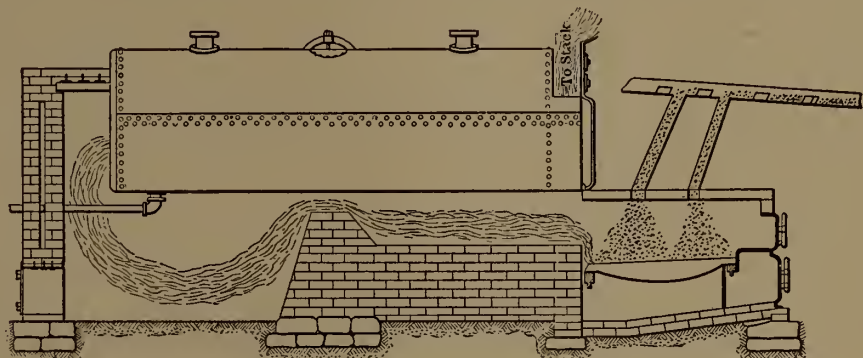

SCHEME FOR BURNING SAWDUST.

sawdust are so much different from those used in burning coal that a novice or inexperienced man finds it a very difficult task. I have obtained the best results with a furnace and boiler setting as shown in the accompanying sketch.

The boiler setting itself is like that usually used in a horizontal boiler, but instead of the grates being under the boiler they are in an oven or projection built in front of the boiler setting. This oven is about 10 feet long and the full width of the boiler. If convenient to do so, I would make it at least 2 feet wider than the boiler. Grates with 1/4-inch opening seem to be the best for this purpose. The sawdust is brought by a mechanical carrier of some kind and dropped through two chutes on to the grates, where it lies in two cone-shaped piles covering the entire grate surface, and burning principally around the edges where the draft will force itself up through the fuel.

In starting the fire, shavings or any other dry material should be used, but after it is well

and displace the brick. The ring forming the hole may be made of cast iron and should be about 14 inches in diameter with a flange 4 inches wide and a lip about 7 inches deep. If the sawdust is dry, a smaller grate surface is used than when the sawdust is green, in which case it is better to allow plenty of surface. When the arch gets hot, the sawdust burns from the top, hence there is little or no smoke.

The arch should be built of a nearly circular form of special radial brick. These should be about 9 inches long, 4 inches thick, the inner depth 2 inches and the outer 2 1/2 inches. It should be well stayed on the sides, and it is good practise to put a piece of heavy railroad iron across the front. If built in this manner it should last a number of years.

About 140 cubic feet of sawdust equals one cord of Norway pine slabs. If there are any further details wanted, ask for them, for we burn it here in all ways and under all conditions.

THE Canada Lumberman

AND WOOD-WORKER

(Monthly and Weekly Editions—One Dollar Per Year.)

PUBLISHED BY

The C. H. Mortimer Publishing Company
of Toronto, Limited,

CONFEDERATION LIFE BUILDING, TORONTO.

BRANCH OFFICES:

38 ALLIANCE BUILDING, MONTREAL.
720-721 UNION BANK BUILDING, WINNIPEG.
22 GREAT ST. HELENS, LONDON, E. C.
536 HASTINGS STREET, SUITE 3, VANCOUVER, B. C.

The Lumberman Weekly Edition is published every Wednesday, and the Monthly Edition on the 1st day of every month.

TERMS OF SUBSCRIPTION:

One Copy, Weekly and Monthly, One year, in advance, \$1.00
One Copy, Weekly and Monthly, Six Months, in advance, 50

Foreign Subscription, \$2.00 a Year

ADVERTISING RATES ON APPLICATION.

THE CANADA LUMBERMAN AND WOOD-WORKER is published in the interest of and reaches regularly persons engaged in every part of Canada in the lumber, wood-working and allied industries. It aims at giving full and timely information on all subjects touching these interests, and invites free discussion by its readers.

Special care is taken to secure for publication in the WEEKLY LUMBERMAN the latest and most trustworthy market quotations throughout the world, so as to afford to the trade at home and abroad information on which it can rely in its operations.

Advertisers will receive careful attention and liberal treatment. For manufacturing and supply firms wishing to bring their goods to the attention of owners and operators of saw and planing mills, wood-working factories, pulp mills, etc., the CANADA LUMBERMAN AND WOOD-WORKER is undoubtedly the most direct and profitable advertising medium. Special attention is directed to "WANTED" and "FOR SALE" advertisements, which are inserted in a conspicuous position on front page of the Weekly Edition.

FIRE INSURANCE FOR THE LUMBER TRADE.

Perhaps no question affecting the lumber trade has been more discussed in recent years than that of fire insurance. This has been due in a large measure to the increased cost of carrying insurance on saw mills and lumber yards and in some degree to the growing belief that the business secured from lumbermen has not been so unprofitable as has been claimed by the underwriters. The formation of several mutual insurance companies in the United States to carry lumber risks exclusively has also served to bring the question to the foreground, and, if we can judge by the results accomplished during the first few years of their existence, they are likely, eventually, either to secure most of the business in this line or force the board companies to reduce their rates.

The first consideration, when about to place insurance, should doubtless be the ability of the company to meet its obligations. Any doubt in this respect greatly lessens the value of the insurance. Lower rates should be little inducement where they carry with them the suggestion that, in the event of a fire, the amount of the policy for which annual premiums are being paid may not be forthcoming. Having absolute security in this respect, it follows that the buyer of insurance is desirous of receiving the lowest possible rate.

Lumbermen are by no means satisfied with the insurance situation existing in Canada today. They claim that the average rate of premium is excessive and that the companies do not classify their risks as they should, with the result that a mill or yard equipped in every respect with fire fighting appliances is charged with a portion of the expense of providing indemnity for risks possessing the maximum hazard. Such inadequate classification removes the incentive to undertake improvements with the object of lessening the danger of fire, a fact

which does not seem to have been given due consideration by the underwriters.

Most of the mills in Ontario are, we believe, paying about six per cent., and if statistics were available, we are inclined to the opinion that this rate would show a very liberal margin of profit. The statement of a mill owner, published elsewhere in this number, that the rates of the board companies are higher than in the United States, would lead to this conclusion. How far the competition of the mutual companies have affected rates in the United States we are not prepared to say, but doubtless they have been the means of keeping them within more reasonable bounds.

The insurance of saw mills was discussed at a meeting of the Vancouver Board of Trade a short time ago, when Mr. Beecher, of the British Columbia Mills, Timber & Trading Company, stated that rates had been practically doubled, in fact, compound insurance rates were exacted. As an instance, he quoted the Hastings mill, which is one of the best risks on the Coast, yet the rate on the mill is extra because of the boiler house; the rate on the boiler house is extra because of the dry kiln; it compounds each way and makes a total which is simply outrageous. The present minimum rate in British Columbia is $3\frac{1}{2}$ per cent. This, however, calls for such conditions that no mill built before these rates came into existence—about eighteen months ago—can meet them, and therefore extras are charged up to a maximum of 10 per cent. The average rate of insurance on modern British Columbia mills is about 7 per cent. Many lumbermen express the opinion that it would be better to abolish the maximum limit unless a more equitable method of rating is adopted. A certain mill, for instance, is assessed at the minimum of $3\frac{1}{2}$ per cent. to begin with, then the extras are added at the will of the underwriters, till perhaps 9 per cent. is reached. Another mill, not nearly so well equipped for fire protection, is also assessed at the $3\frac{1}{2}$ per cent. to begin with and the extras added until, if carried out in proportion to the other mill, they would reach probably 15 or 16 per cent. However, as there is a limitation of 10 per cent., the mill with practically no fire protection is assessed at only one per cent. more than the first mill, although there is no comparison in the risk.

We understand that a number of lumbermen, believing that the expense is excessive, have decided to carry their own insurance until such time as they are able to obtain more satisfactory terms. These may be secured by the formation of a mutual insurance company among the lumbermen of Canada. Such a company, entering into competition with the existing companies, would be almost certain to cause a reduction in rates, and there is no reason to believe that the plan which is working out so successfully in the United States could not be adopted with advantage in this country.

The columns of the CANADA LUMBERMAN are open for a discussion of the question.

This journal aims to promote the interests of all lumbermen. Its columns are intended for a discussion of all subjects affecting the magnificent industry it represents.

THE FELLING OF TIMBER.

The Russian *Lesopromishlenny Vestnik*, a journal published in the interest of the timber trade, contains in a recent issue some pertinent remarks regarding the preservation of the forests. In Russia, as in this country, it is the custom to cut only trees of certain dimensions, the limit being $10\frac{1}{2}$ inches diameter at the top in the Government forests and 7 inches in private lands. An examination of the felled areas in after years has revealed a large quantity of dry standing timber. Our contemporary contributes this deterioration to the thinning of the forests by felling the merchantable trees to such an extent that the remainder are swayed by the wind, and through the continual rocking movement the smaller fibres of the root break in the ground, the consequence of which is that the tree receives insufficient nourishment. After that its complete destruction is but a matter of time.

The system above referred to, and its injurious effects, are not unknown in Canada; indeed, it is claimed that in New Brunswick and Nova Scotia the forests in many parts are being ruined in the same manner. The loss is not confined to the dry timber, as the existence of this timber is likely to attract insects and the whole forest be damaged thereby. What have our lumbermen and foresters to say on the question?

PULP AND PULP WOOD DUTIES.

The United States Treasury Department at Washington has recently given two rulings affecting the pulp industry which, to say the least, has created some surprise. The first of these provides that rossed pulp wood imported into the country shall be subject to the duty of 20 per cent. specified in Section 200 of the Dingley Act, on the ground that it is a manufactured article. Such a decision was unexpected, inasmuch as the rossed wood duty was first assessed about two years ago but was suspended pending the final decision by the courts. The Government, however, never pressed the appeal, and it was generally supposed that the question had been finally disposed of and that such wood was to be given free entry into the country. The pulp and paper manufacturers of the United States are affected by the duty, as the cost of the raw material imported from Canada, which is a considerable quantity, will be substantially increased. Pulp wood exporters in this country, and particularly in Quebec, are also somewhat exercised over the ruling, which if sustained by the courts, will result in a curtailment of the pulp wood exports. Canadian pulp manufacturers, on the other hand, are perhaps in sympathy with the decision of the Treasury Department.

The second ruling is less favorable to our pulp manufacturers and more than offsets any advantage likely to accrue through the restriction placed on the export of the raw material in rossed form. By it all pulp imported from Quebec, whether manufactured from wood cut on Crown or private lands, must pay the countervailing duty assessed under paragraph 393 of the Tariff Act. This section reads: "Provided, that if any country or dependency

shall impose an export duty on pulp wood exported to the United States, the amount of such export duty shall be added, as an additional duty, to the duties herein imposed upon wood pulp, when imported from such country or dependency."

The Province of Quebec charges stumpage dues on pulp wood of 65 cents per cord, and allows a rebate of 25 cents for timber manufactured within the Province. This is interpreted by the Washington Government as being an export duty within the law. There is at time of writing some doubt as to whether it is the intention that the additional duty shall apply to pulp manufactured in Quebec only or in all parts of Canada.

On the whole, the United States seems to be more disturbed by the new duties than does Canada. They want our pulp wood, and if they cannot get it will have to buy our pulp to a greater extent than in the past. The legislators of Quebec should not change their policy of endeavoring to build up the pulp and paper manufacturing industry, but should go a step farther than they have and prohibit entirely the exportation of pulp wood. Perhaps the little disturbance which the new duties have caused may lead to legislation beneficial to Canada.

THE WINNIPEG EXHIBITION.

The Winnipeg Exhibition brought out quite a number of exhibitors in the lumber and wood-working section. Among the more prominent was the exhibit made by Geo. W. Murray, consisting of high grade sash and doors, office and store fittings, etc. Mr. Murray's sash and door factory has lately been remodelled. The floor space is now equal to 30,000 square feet and in addition the plant contains four new sectional dry kilns. These recent improvements make it one of the best factories in Western Canada.

The Winnipeg Paint & Glass Company, who deal extensively in lumber, made a very neat exhibit of several city houses which had been supplied by them. These miniature reproductions were correctly painted and showed how wooden houses could be made very attractive.

Messrs. Shurley & Deitrich, of Galt, Ont., had a most comprehensive exhibit of saws, all of which were of their famous Maple Leaf brand. The saws used for lumbering purposes, including circular and band saws, were greatly admired. They occupied the entire end of No. 3 manufacturers' building.

Some saw mill machinery was shown by the Stuart Machinery Company, Limited, of Winnipeg.

The Alsip Brick, Tile & Lumber Company displayed a very unique line of builders' materials.

The Cream City Sash & Door Company, of Milwaukee, were represented by the E. A. Delius Company, of Winnipeg, who made quite a display.

Logging by water in East Texas is said to be gradually yielding to the more convenient or economical employment of logging railroads.

In an article entitled "The Broker," written by Vice-President Somerville, of the Southwestern Washington Lumber Manufacturers' Association, appearing in an exchange, the statement is made that shingles at one time reached the low price of eighty-five cents.

JOTTINGS BY THE WAY

There will always exist, we suppose, a certain amount of prejudice in business transactions. Of late years, with the introduction of larger and improved saws, it has become the custom of some lumbermen to square hardwood timber, say 10 x 10 and up, in the mill. When it passes into the hands of the Quebec shippers, who know thoroughly the whims of the British buyers, they frequently put it through the process of hewing, although in what way the timber is thus improved or rendered more acceptable is not very clear. The opinion was recently ventured that it was done to give the impression that the timber had been cut from a virgin limit, as many of the limits from which sawlogs are now being obtained were once lumbered for square and waney timber.

* * *

Talking to a lumberman from the State of Washington, he says that there is practically very little of their lumber or timber being shipped into Canada this year, but they could not guarantee to "dump" when dumping was necessary. This gentleman was from Lewis county, which is situated a few miles north of Portland, in Washington. Timber is its principal resource, and is almost without limit. The estimated standing supply is 8,500,000,000 feet, board measure. Last year 225,000,000 feet were turned out into various articles, and the shingles cut in Lewis county numbered 190,000,000. There is an immense sash and door factory at Centralia, as well as the largest wooden gutter factory in the world. Chehalis, in the same county, is a centre for furniture manufacture.

* * *

There are yet many openings in Canada for manufacturing industries whose raw material is timber. A gentleman was recently in Toronto exploiting the market for wooden columns, although he was already aware that there existed in this country no small demand for these goods. He represented an American firm which had been importing Canadian lumber and consequently paying a duty thereon of two dollars per thousand feet, manufacturing the lumber into columns, and shipping some of the columns into Canada, subject, of course, to a duty of twenty-five per cent. These columns are made largely from clear pine costing sometimes as much as one hundred dollars per thousand feet. Recognizing the advantages which a home factory would possess in supplying the Canadian trade, this gentleman was looking around for a suitable location. The duties on the lumber and the finished article alone represent a very acceptable profit, not to speak of the increased business which would likely be thus secured.

* * *

The British Columbia mill men are now petitioning the Canadian Railway Commission to reconsider its decision whereby cedar lumber was placed on the basis of fir. The Canadian Pacific Railway is the instigator. It has

threatened the British Columbia mill men with an advance in fir rates. The lumbermen are supremely foolish to allow themselves to be taken in in this way. The Canadian government, extremely solicitous of its colonization scheme in the Northwest Territory, will not tolerate an advance in rates for a minute, and the Canadian Pacific knows that the protest that would go forth in the event of an advance would be so strong that its action would be rescinded. If the commission should acquiesce, the British Columbia mill men will never have any standing with the railway company. The law of discrimination is very plain, and this journal will be very much surprised if the commission reverses itself.—Pacific Coast Lumber Trade Journal.

* * *

In an interview with Mr. C. H. Wheeler, the well known Winnipeg architect, he stated that half a million feet of lumber was made in one day by one of the mills of the Rainy River Lumber Company. This shows a remarkable growth of the lumber industry in the centre of Canada within 150 miles of Winnipeg. The Rat Portage Lumber Company also employ many hundreds at their mills at Kenora (which, by the way, is the new name for Rat Portage). The town of Rainy River is becoming quite a centre for the lumber industry and in population will soon rival the town of Fort Francis. Mr. Wheeler had a run up the river on a gasoline launch and states that the water sides were piled with logs on which the lumber jacks were working and sorting for driving down to the mills. Mr. S. Youhill, of Rainy River, has a large financial interest in logging and he calculates that there is at least seventy million feet of log timber now on the river awaiting the saws of the Rat Portage and the Rainy River companies. The logging industry of the Rainy River country is flourishing and the river itself being wide and deep is navigable for nearly one hundred miles from its outlet at the Lake of the Woods.

WHAT CONSTITUTES "MILL RUN."

SEAFORTH, ONT., August 7th, 1905.

Editor CANADA LUMBERMAN :

DEAR SIR,—Your quotations for rock elm, soft elm and maple are all mill run. An expert lumber inspector told me the other day that all mill culls and hearts were taken out of the mill run lumber. Now, sir, I don't claim to be an expert at the lumber business, but if all mill culls and hearts are thrown out, then what is left should grade common and better. I would like you to give me your opinion in the next issue of the LUMBERMAN.

A SUBSCRIBER.

ANS.—While, unfortunately, there are no recognized rules in Canada for the grading of hardwood lumber, we believe it is generally admitted that "Mill Run" should include the entire product of the log excepting dead culls, which are considered to be refuse and not marketable lumber. The grades adopted by the Hardwood Manufacturers' Association of the United States are: Firsts and seconds; No. 1 common; No. 2 common; No. 3 common; No. 4 common; and scoots. "Log Run" is described to mean the full run of the log with all grades below No. 3 common out. The grades of the National Hardwood Lumber Association are: Firsts; seconds; No. 1 common; No. 2 common; and No. 3 common. "Log Run" is designated the full run of the log with No. 3 common out.

OTTAWA VALLEY LUMBERMEN EXTEND HOSPITALITY

Interesting Midsummer Meeting of the National Wholesale Lumber Dealers' Association. Entertainment Features Greatly Enjoyed.

The invitation of the Ottawa Valley lumbermen, extended by Mr. Gordon C. Edwards to the National Wholesale Lumber Dealers' Association, to hold a midsummer meeting in Ottawa, was accepted by about one hundred members, and it may be truly said that the proceedings from beginning to end were thoroughly interesting and enjoyable. The following invitation was issued to the members and friends:



The Ottawa Valley Lumber Manufacturers request the pleasure of the company of The National Wholesale Lumber Dealers Association and their guests to partake in the following programme.

AUGUST SIXTEENTH. Evening sail down the Ottawa River. Steamer will leave the Empress wharf eight o'clock.

AUGUST SEVENTEENTH. Drive around the City of Ottawa. Luncheon leave Russell House Three o'clock P.M. Steamer same evening at Russell House eight o'clock.

AUGUST EIGHTEENTH. Boat up Lake Deschêne. Can leave Empress wharf for Supt. at eight thirty o'clock A.M.

An answer is requested to Secretary C. Edwards, Ottawa, Ontario.

Among those present at the meeting were the following:

H. J. Amos (Nellis, Amos & Swift), Utica, N. Y.
 Fred W. Avery (Hull Lumber Co.), Hull.
 F. R. Babcock (E. V. Babcock & Co.), Pittsburg, P. A.
 E. A. Beckley (Crosby & Beckley Co.), New Haven, Conn.
 Killam E. Bennett (Munger & Bennett), Camden, N. J.
 Franklin B. Betts, (Charles M. Betts & Co.), Philadelphia, Pa.
 A. P. Bigelow, New York.
 J. B. Blades (Blades Lumber Co.), Newbern, N. C.
 L. S. Blades (Blades Lumber Co.), Newbern, N. C.
 J. R. Booth and Fred Booth, Ottawa.
 W. H. Bromley (Pembroke Lumber Co.), Pembroke, Ont.
 Owen M. Bruner, (Owen M. Bruner Co.), Philadelphia, Pa.
 S. S. Burkholder (Burkholder Lumber Co.), Crawfordsville, Ind.
 R. G. Cameron (Cameron & Co.), Ottawa, Ont.
 W. A. Cameron (Cameron & Co.), Ottawa, Ont.
 A. C. Campbell (Robinson-Edwards Lumber Co.), Burlington, Vt.
 R. H. Campbell (Secretary Canadian Forestry Association), Ottawa.
 Albert Cone (American Lumberman), Chicago.
 George F. Craig (George F. Craig & Co. and George Craig & Sons), Philadelphia, Pa.
 W. A. Crombie (W. M. Crombie & Co.), New York.
 W. O. Curtiss, Boston Mass.
 James Sherlock Davis, New York.
 J. E. Defebaugh (Editor American Lumberman), Chicago.
 W. W. Dempsey, Johnstown, Pa.
 Lewis Dill (Lewis Dill & Co.), Baltimore, Md.
 Parker D. Dix (Surrey Lumber Co.), Baltimore, Md.
 R. H. Downman, New Orleans, La.
 E. J. Eddy (traffic manager National Wholesale Lumber Dealers' Association), New York.
 A. H. Edwards (Williams, Edwards & Co.), Ottawa, Ont.
 Gordon C. Edwards (W. C. Edwards & Co., Limited), Ottawa, Ont.
 H. K. Egan (Hawkesbury Lumber Co.), Hawkesbury.
 B. H. Ellington (Ellington & Guy), Richmond, Va.
 Samuel R. Ely, R. H. Downman, New Orleans, La.
 J. W. Farrow (J. W. Farrow & Co.), Birmingham, Ala.
 Harry S. Field (Justice P. Taylor & Co.), Philadelphia, Pa.
 J. B. Flint (Flint, Erving & Stoner), Pittsburg, Pa.
 J. W. Foreman (Blades Lumber Co.), Elizabeth City, N. C.
 W. H. A. Fraser (Fraser & Co.), Ottawa.
 William H. Fritz (William H. Fritz & Co.), Philadelphia, Pa.
 William H. Fritz, jr. (William H. Fritz & Co.) Philadelphia, Pa.
 George W. Gale, Boston, Mass.
 Edgar S. Gardner (cashier Ridge Avenue bank), Philadelphia, Pa.
 S. J. Geash (Brockville Lumber Co.), Brockville, Ont.

W. M. Gillespie (D. L. Gillespie & Co.), Pittsburg, Pa.
 M. P. Harlow (Harlow & Todd), Hartford, Conn.
 J. M. Hastings (J. M. Hastings Lumber Co.), Pittsburg, Pa.
 E. B. Hayman (William H. Fritz & Co.) Philadelphia, Pa.
 Guy L. Hayman (William H. Fritz & Co.) Philadelphia, Pa.
 R. E. Higbie, New York.
 W. C. Hughson (Gilmour & Hughson), Hull, Que.
 George Wilson Jones, Utica, N. Y.
 A. E. Kaiser (Cleveland-Sarnia Saw Mills Co.), Sarnia, Ont.
 J. L. Kendall (H. C. Huston Lumber Co.) Pittsburg, Pa.
 John C. King (King & Bartles Lumber Co.) Cleveland, Ohio.
 W. W. Knight (Long-Knight Lumber Co.) Indianapolis, Ind.
 George D. Lansing, Providence, R. I.
 W. C. Laidlaw, Toronto, Ont.
 F. W. Lawrence (Lawrence & Wiggin), Boston, Mass.
 J. W. Long (New York Lumber Trade Journal), New York.
 J. J. McKelvey (general consul), New York.
 R. H. McKelvey (Lumber Insurance Co.), New York, N. Y.
 Hugh McLean (Hugh McLean Lumber Co.), Buffalo, N. Y.
 Angus McLean (Hugh McLean Lumber Co.), Buffalo, N. Y.
 D. H. McLennan (Bulmer, McLennan & Co.), Montreal, Que.
 Louis A. Mansfield, New Haven, Conn.
 J. E. Mar (Lumber Underwriters), New York.
 V. R. Marshall (Brockville Lumber Co.), Brockville, Ont.
 George H. Mell, Kane, Pa.
 Fred S. Morse (Fred S. Morse Lumber Co.), Springfield, Mass.
 Theodore Mottu, Baltimore, Md.
 G. H. Muir (CANADA LUMBERMAN), Toronto, Ont.
 John C. Orr, New York.
 D. Walde Parrott, Providence, R. I.
 George Perley (G. H. Perley & Co.), Calumet.
 E. F. Perry (secretary National Wholesale Lumber Dealers' Association), New York.
 Justin Peters (Pennsylvania Lumber Mutual Fire Insurance Co.), Philadelphia, Pa.
 Maurice E. Preisch (Haines Lumber Co.), Buffalo, N. Y.
 C. H. Prescott, jr. (Saginaw Bay Co.), Cleveland, Ohio.
 J. S. Rayside (Lawrence & Wiggin), Boston, Mass.
 J. H. Redfern, Montreal, Que.
 James M. Reilly, Newark, N. J.
 James A. Rich, New York.
 Frank C. Rice (Rice & Lockwood Lumber Co.), Springfield, Mass.
 L. P. Rider (White, Rider & Frost), New York.
 Daniel W. Robinson (Robinson-Edwards Lumber Co.), Burlington, Vt.
 W. H. Russe (Russe & Burgess), Memphis, Tenn.
 W. W. Schupner (asst.-secretary National Wholesale Lumber Dealers' Association), New York.
 E. A. Shepard (A. L. Shepard Lumber Co.), Richmond, Va.
 George M. Stevens, jr. (Stevens-Eaton Co.), New York.
 E. Stewart (Dominion Superintendent of Forestry), Ottawa.
 J. V. Stinson, Huntingburg, Ind.
 A. L. Stone (Nicola, Stone & Myers Co.), Cleveland, Ohio.
 M. S. Tremaine (Montgomery Door & Box Co.), Buffalo, N. Y.
 A. M. Turner (A. M. Turner Lumber Co.), Pittsburg, Pa.
 Dwight J. Turner (Turner Lumber Co.), Midland, Ont.
 Nelson H. Walcott (L. H. Gage Lumber Co.), Providence, R. I.
 J. B. Wall and sons, Howard, Maurice and Harold (Buffalo Hardwood Lumber Co.) Buffalo, N. Y.
 George E. Waters, Baltimore, Md.
 Peter Whelan (Shepard & Morse Lumber Co.), Ottawa.
 Pendennis White (White, Gratwick & Mitchell), North Tonawanda, N. Y.
 R. P. White (D. L. White & Co.), Albany, N. Y.
 Richard S. White (president Eastern States Retail Lumber Dealers' Association), New York.
 Walter G. White (Hull Lumber Co.), Hull, Que.
 Hugh M. Williams (Williams, Edwards & Co.), Ottawa, Ont.
 J. C. Wood, Muncie, Ind.

Mr. W. C. Hughson, Chairman of the Canadian Entertainment Committee, extended a hearty welcome to the delegates.

The President, Mr. Lewis Dill, presided, and made a brief opening address. Mr. E. F. Perry, secretary, presented a very sanguine report. The membership of the association on August 1 was 344 as compared with 314 on

March 1, 1905. Reference was made to the good work done by the various departments of the association, including the railway and transportation department and the credit department or bureau. The latter report said in part:

"Since March 1st of this present year special emphasis had been laid upon the fact that the legal department or collection department of the association,



MR. W. C. HUGHSON,
Chairman of the Entertainment Committee.

is now being handled directly through the Bureau of Information, and under supervision of the Board of Managers. We have been very much encouraged by the numerous letters received from our members, referring to the manner in which many of these collections have been handled. This department has developed along a line somewhat different from that expected at the outset. Probably one half of the amount of the claims that we have handled this year have been somewhat on the basis of arbitration; in other words have largely been settled by negotiation. It would seem that our members would find it very much more



MR. GORDON C. EDWARDS,
Secretary of the Entertainment Committee.

satisfactory to handle all their claims through this department rather than take them directly into the courts. This department is conducted on a basis which we believe warrants our urging members to place with the association all their collections. The charges are low, much lower than could be had through local attorneys, and with the experience that we have continually gained our members are placed in a position where they should have confidence in this department, and feel safe in placing with it all claims of any character; in fact, we believe this is one of the most valuable features of membership in our association. The mere demand upon a delinquent in the name of the association has in many instances been the means of immediate settlement, or adjustment of

claims, and it is a privilege which the members should feel free to exercise. After we have exhausted our resources, claims are referred to attorneys if desired or thought necessary for your protection. Our system of guaranteed attorneys places us in position to handle your claims through high class lawyers in any city of the United States or Canada, assuring you that you will get your money if collected.

"I am pleased to be able to report that the Railroad & Transportation Department seems to be receiving the encouragement of the members of the association, and we believe this department will soon get to a point where it will appeal to you, and where you will find a haven for those annoying claims which always seem to be turned down by the railroads once or twice before they reach an official who is willing to give them proper consideration. In again referring to the car stake and car equipment proposition which comes under this department, we wish to urge your support even though you may not feel you are directly interested in the subject because you may not often be required to equip cars."

Mr. F. R. Babcock submitted the joint report of the Railroad and Transportation and Legislative Committee, which contained a recommendation of the Executive Committee that a complaint be prepared and filed with the Interstate Commerce Commission against the various railroads operating under official classification territory, providing that the roads be required to furnish the necessary car stakes and racks to properly protect lumber when shipped on flat and gondola cars in compliance with the rulings of the various roads, and to make the proper allowance for freight thereon.

Mr. R. W. Higbie submitted the report of the Committee on Legislation, which referred particularly to the relations existing between the lumbermen and the railroads in respect to the furnishing of car stakes.

In the evening the lumbermen, accompanied by their lady friends, enjoyed a trip down the Ottawa river on the steamer "Empress." An orchestra accompanied the party and furnished sweet music.

Resuming for business on Thursday morning, the report of the Committee on Fire Insurance was presented, recommending that the rates of insurance should be based on the conditions found to exist in each lumber yard. Mr. Pen-dennis White, of the Lumber Underwriters, New York, spoke on how some companies have reduced losses and given better satisfaction by having inspectors examine each risk, consider the surrounding hazards, the way the yard is kept, etc., and then making a special rate for each risk instead of having one rate to cover various risks.

Mr. E. Stewart, chief of the forestry branch of the Department of the Interior, addressed the members of the association on the desirability of preserving the young timber. A contribution on the subject appears elsewhere in this number.

Then arose a very lively discussion concerning the complaint which has been filed with the Interstate Commerce Commission against all the railroads east of the Mississippi river, alleging unjust discrimination by the said railroads against lumber shippers. The complaint in brief is that the lumbermen in shipping construct their own racks and stakes on flat cars, such costing about \$6 per car, and are not allowed any discount on freight rates to cover such stakes. Other shippers get the benefit

of a freight reduction for the weight of the stakes. It is also claimed that the railways bear the expense of racks required for other commodities. A complaint was filed with the commission by the National Wholesale Lumber Dealers' Association and on the recommendation of the railroad and transportation committee a joint convention of the association and the delegates from other associations was held. This joint convention unanimously endorsed the action of the National association and committees were appointed to secure the co-operation of all lumber associations in providing ways and means and in pressing the complaint before the Interstate Commission.

This ended the business meetings, and in the afternoon the party were driven around in the city. The dinner tendered by the Ottawa Valley manufacturers at the Russell House on Thursday evening was thoroughly enjoyable and successful in every way. The beauty of the large dining room was enhanced by lavish decorations, emblematic of the woods, with pine, spruce boughs and other woodland effects in flowers and foliage. From a sylvan nook an orchestra rendered excellent music during the evening.

Covers were laid for one hundred and fifty guests. The menu card was unique, the letter text including the following :

- Specification
- Chopped from a White Pine Stump.
- Skidded with Tongs, if you please.
- Little Neck Clams.
- Laid on the Ice.
- Bouillon—"Shaky Clear."
- Down the river, (not the Pike).
- Restigouche Salmon.
- Into the Boom.
- Fillet of Beef-a la Chicago and Beans.
- New Peas.
- A Good Deal.
- Roman Punch.
- Gang Sawn, full width and thickness.
- Spring Chicken, Potatoes Natural.
- Edged and Trimmed.
- Salads.
- Fancy Forms of Ices.
- Assorted Cakes.
- Piled Ninety Days on Sticks.
- Roquefort and Camembert Cheese.
- Free Stakes.
- Coffee.

From the first course to the last all was served to the King's taste.

Mr. John R. Booth, Ottawa's veteran lumberman, was chairman and associated with him as toast master was Senator Edwards. Toasts to His Majesty, the King, and to the President of the United States were honored with enthusiasm. "Our Guests" was then proposed by Senator Edwards and Mayor Ellis. Mr. Lewis Dill, president of the association, was most happy in his reply. He paid a graceful compliment to the hosts of the evening when he said: "It has been said that the United States will not get another opportunity to annex Canada, that it has had several opportunities to do so and has missed them. I want to say on behalf of the National Wholesale Lumber Dealers' Association that we don't wish to annex Canada any more. We consider that we have been annexed."

Mr. W. H. Russe, Memphis, Tennessee, in moving a resolution of appreciation of the hospitality of the lumbermen of the Ottawa valley, proposed the health of Mr. Gordon C. Edwards. This toast, and the next toast, to Mr. J. R. Booth, were both impromptu and both were honored with marked enthusiasm. The final toast, "The Ladies," brought pleasing addresses from Mr. J. G. Foster, United States consul general, and Mr. W. L. Mac-kenzie King.

Mr. Albert E. Heney recited a nomination speech "Up the Gatineau" and other habitant selections in his own excellent style and the Americans were particularly delighted. Mr. Cecil Bethune was also most pleasing in his rendering of "The Maple Leaf" and "Loch Lomond."

On Friday morning the delegates were taken in hand for a sale up the river on the steamer "G. B. Greene." Cars left Sappers Bridge for Aylmer at 8.30. The trip was greatly enjoyed. The party returned to Ottawa early in the afternoon, and many of the delegates left for their homes on the evening trains.

The local committee in charge of the entertainment features of the meeting consisted of W. C. Hughson, chairman; Gordon C. Edwards, secretary; Fred Booth, W. H. A. Fraser, George Perley, H. K. Egan, Fred W. Avery and Peter Whelan.

Writing to the CANADA LUMBERMAN concerning the convention, Mr. Owen M. Bruner, wholesale lumber dealer, Philadelphia, says: "In regard to the convention held last week at Ottawa, I believe that it excelled any of the past conventions, in fact, never in the history of the lumber business was there a meeting of such importance to the lumbermen. The feeling of good fellowship between the Canadian and United States lumbermen was very noticeable. The Ottawa Valley lumbermen acquitted themselves most creditably as hosts. Every attention given to visitors was most cordial. The entertainment provided was of the best, and I am sure was thoroughly appreciated by the visitors."

A NEW WESTERN FIRM.

We beg to call attention to the advertisement of Messrs. Hinrichs & Pace, manufacturers and engineers, who have headquarters at Revelstoke, B.C. This young and enterprising firm are dealers in and equippers of heating and ventilating appliances, blowers and shavings systems. They were formerly connected with the well-known firm of Sheldon & Sheldon, of Galt, Ont.

The new plant operated by the Bowman Lumber Company was installed by Hinrichs & Pace, and this is the testimonial they received:—

REVELSTOKE, B.C., July 17, 1905.

The undersigned take great pleasure in recommending Messrs. Hinrich & Pace to any firm requiring their services as blower system experts. They have installed a complete system in our Comaplix mill and it could not work better.

If any further information is desired regarding their ability, this company will be more than pleased to furnish same.

These gentlemen have our very best wishes for future success.

(Signed) BOWMAN LUMBER CO., LTD.

The Stuart Machinery Company, Winnipeg, propose to increase their capital stock from \$49,000 to \$200,000.



THE HOO-HOO ANNUAL.

The Hoo-Hoo excursion to Portland, Oregon, and returning via British Columbia and the C. P. R., left Toronto August 31st, in charge of Mr. Donald Ferguson, Vicegerent Snark for Eastern Canada. The party went by way of Denver, Colorado Springs and Salt Lake City and expect to reach Portland on the 7th inst.

BURNING OF THE ABERDEEN MILLS.

The Aberdeen mills of Donald Fraser & Sons at Fredericton, N. B., were totally destroyed by fire on August 11th, together with about five million feet of lumber. The following account of the fire has been furnished.

The mill, which was situated on the river bank, was one of the best equipped mills to be found anywhere, and with machinery costing in the vicinity of \$30,000. In front of this building and situated on the road side is the large Aberdeen boading house. Below the mill was a large storehouse that at the time of the fire was filled with box shooks valued at about \$15,000. Below these buildings and extending down the road several hundreds of yards and reaching back to the river, were many acres, tier on tier, of piled saved lumber, chiefly spruce and pine, amounting altogether to about ten millions of feet.

About a quarter to six in the evening the men in the lower floor near the centre of the mill saw a flame shoot up from below, and before some of them had time to catch up anything, the fire broke forth in tremendous fury. As it was, a number had difficulty in escaping, so rapidly did the flames spread. The fire alarm was rung in as quickly as possible, but in five minutes the whole structure was one mass of flames.

The shed on the river bank soon became ignited, and from the bank the conflagration rapidly spread to the lumber.

Vast crews of men worked hard and earnestly to remove the lumber which had not yet been touched, and with teams managed to take away some thousands of feet. The steam

engine Amoskeag was brought up from Victoria Mills and stationed at the river bank, and supplied two good streams. After it became evident that the lumber could not be saved, the firemen turned their whole attention to saving the big Aberdeen boarding house and the residence on the opposite side of the street. For three hours they fought hard. Carpets and material of all kinds were spread in front of the buildings and streams turned on. In spite of all, the structures would catch, and it was a warm and interesting contest. Finally the men were rewarded, and all these buildings were saved. At 10.30 the fire was under control. The loss is estimated at \$100,000, insurance \$35,000. About 125 hands are turned out of employment.

Donald Fraser stated a few days after the fire that nothing had been decided upon as to rebuilding. It would be impossible to get a mill running this season, and arrangements would be made to have the company's logs sawn in St. John, and they hoped to be able to fill the contracts they had made. Fraser & Sons own and operate large mills at Plaster Rock and Cabano, the latter being one of the largest and best saw mills in the country.

EARLY LUMBERING OPERATIONS.

(From an address by the Hon. J.K. Ward before the Natural History Society, Montreal in 1895.)

The first timber shipped to Europe from Canada was sent from Quebec to Larochele by Tallon in 1667. Lieut. Hocquart shipped timber and boards to Rochefort in 1735. In 1823, 300 cargoes were shipped from Quebec.

In the early part of the present century the Montmorency mills were established by a Mr. Usboirne. Mr. Peter Patterson, a ship carpenter by trade, who had spent some time in Russia, became an employee of Mr. Osboirne's and finally proprietor of the property, and became one of the largest manufacturers of lumber in Canada. Sir John Caldwell established mills at Riviere-du-Loup en Bas and at Etchemin. The late William Price, father of the Hon. J. Price, of Quebec, established large mills at Chicoutimi, St. Alexis, L'Anse, St. Jean, St. Etienne, Batiscan, Matane and many other places, leaving an immense business to his sons, which is now conducted by the son before named. The late Allan Gilmour and relations of the same name carried on for many

years a large business on the North Nation, the Gatineau and Mississippi (Canada), and at Trenton, Ont., the younger branches of the family continuing the business.

Philomene Wright, the first lumberman on the Ottawa river, came from Woburn in the United States, arriving at the Chaudiere Falls—or the Asticou, as called by the Indians—as early as the year 1796. It was not till 1797 that he finally decided to make his home in Canada, and on the 20th of October, 1799, he and two companions pitched upon the site of the future city of Hull. He finally quitted Woburn for Canada on the 2nd of February, 1800. He was accompanied by five families, and had in his train fourteen horses, eight oxen and seven sleighs. The first tree was felled on the site of the homestead on the 7th of March of the same year. He brought the first square timber from the Ottawa to Quebec in the year 1807. He built the first slide on the Hull side of the river in 1829. He was elected the first member to represent the County of Ottawa in 1830. He died in 1839, and sleeps, an honored memory, in the little cemetery on the Aylmer road. Philomene Wright built his first saw and grist mills in 1808; they were, unfortunately, burned down, but were rebuilt in sixty days.

About eighteen years prior to this the first saw mill on the Ottawa had been built at Point Fortune by a Mr. Story. It boasted one upright saw, and it is recorded that when the man in charge gigged back the carriage for a fresh cut he would sit down on the log to take his dinner, and was about through by the time the cut was finished. With our present saws the same can be done in four seconds.

GOOD ADVICE.

Cultivate pleasant relations with your competitors. It makes business life more endurable. Unreasonable jealousy of others' success is the cause of much unwise price cutting and losses.

Good business men are those who know how to make first-class goods by using first-class material and then getting a price for it.

Giving much attention to what a competitor is doing doesn't pay. Exert the same energy in advertising your own business and it will pay larger dividends.

"STERLING" OILS

FOR SAW MILLS

WE SOLICIT ORDERS
TRADE LARGE AND SATISFACTORY
OUR AGENTS WILL CALL WITH "STERLING" CYLINDER,
ENGINE, DYNAMO, MACHINE AND SPECIALTY OILS

Greases, Packing, Waste, "Copperine," Ready Mixed Paints, Varnish, Red and Black Roof Paint; Smoke Stack Black for Boiler Fronts and Sawmill Refuse Burners, White Lead, Dry Colors, Etc.

Canadian Oil Co., Limited
Strachan Avenue, TORONTO, ONT.

Please mention THE CANADA LUMBERMAN when corresponding with advertisers.

Galt Machine Knife Works



MACHINE KNIVES OF EVERY DESCRIPTION
FOR **Woodworking Machines**
... Send for Price List ...
The Peter Hay Knife Co., Limited - Galt, Ont.

CANADA LUMBERMAN

AND WOOD-WORKER

WEEKLY EDITION

The Lumberman Monthly Edition 44 pages} \$1.00 PER YEAR {The Lumberman Weekly Edition every week.

THIS PAPER REACHES REGULARLY THE PRINCIPAL LUMBER MANUFACTURERS AND DEALERS THROUGHOUT CANADA, AND WHOLESALE BUYERS IN GREAT BRITAIN, THE UNITED STATES, AND OTHER FOREIGN MARKETS.

VOL. XIII

TORONTO, MONTREAL — AUGUST 30, 1905 — WINNIPEG, VANCOUVER

No. 26

CANADA LUMBERMAN

PUBLISHED BY

The G. H. Mortimer Publishing Co.'y
of Toronto, Limited

Confederation Life Building - TORONTO.
Branch Offices:

38 ALLIANCE BUILDING, MONTREAL
720-721 UNION BANK BUILDING, WINNIPEG.
Telephone 1274

536 HASTINGS ST., SUITE 3, VANCOUVER, B. C.
22 GREAT ST. HELEN'S, LONDON, E. C.

The Weekly Lumberman — Published every Wednesday, contains reliable and up-to-date reports of market conditions and tendencies in the principal manufacturing districts and leading domestic and foreign wholesale markets. A weekly medium of information and communication between Canadian timber and lumber manufacturers and exporters and the purchasers of timber products at home and abroad.

The Monthly Lumberman — A 44-page journal, discussing fully and impartially subjects pertinent to the lumber and wood-working industries.

WANTED—YOUNG MAN, 22 YEARS OF age, desires position as traveller, 7 years experience in lumber business. Address Box 310, CANADA LUMBERMAN, Toronto, Ont.

WANTED — TEN THOUSAND CORDS Hard and Soft Wood; also same quantity of Slabs. SIMCOE WOOD AND LUMBER CO., 52 Yonge Street Arcade, Toronto.

CEDAR FOR SALE — 10,000 PCS. ROUND Cedar 8-16 and 25 feet long, at the Span'sh boom. Also cedar, pine and spruce lumber for sale here at Larchwood. JAMES MCCREARY, Larchwood, Ont.

FOR SALE

1" and 1 1/2" 1904 winter cut, mill run, trimmed Hard Maple.
Two cars 1" Soft Maple, cheap.
Two cars 1" 1sts and 2nds Soft Elm, 10" and up wide.
1", 1 1/2" and 2" 905 winter cut, mill run, trimmed Hard Maple.
Write for lists and prices. The W. R. THOMPSON CO., Teeswater, Ont.

FOR SALE

White Pine Lumber

NO. 1 SHEET.

Feet
1,895 5/4" x 4" up x 6/11 ft. M/C shorts
2,962 1" x 10" x 12/16 ft. M/C stocks
27,735 5/4" x 4" up x 6/11 ft. S/C shorts
NO. 3 SHEET.
26,945 1" x 4" up x 6/11 ft. sound common
44, 93 5/4" x 4" up x 6/11 ft. sound common
994 1" x 8" x 12/18 ft. sound common
852 6/4" x 4" up x 6/11 ft. sound common
69 1" x 11" x 12/18 ft. sound common
10,567 1" x 4" up x 6/11 ft. second quality
8,234 5/4" x 4" up x 6/11 ft. second quality
69,000 5/4" x 4" up x 12/18 ft. second quality
2,611 5/4" x 8" up x 12/18 ft. second quality
44,400 2" x 4 1/2" x 12/18 ft. second quality
38,457 2" x 6" x 12/18 ft. second quality

NO. 4 SHEET.

118,214 4 1/4" x 6/11 ft. S/C shorts
74,606 5/4" x 4" up x 6/11 ft. S/C shorts
2,521 6/4" x 6/11 ft. S/C shorts
66,271 1" x 8" x 12/16 ft. S/C and better.
2,882 5/4" x 12/16 ft. M/C sidings
39,826 5/4" x 12/16 ft. M/C strips
37,861 5/4" x 4 1/2" x 6/11 ft. M/C shorts
7,435 6/4" x 4 1/2" x 6/11 ft. M/C shorts
3,222 5/4" x 8" up x 6/11 ft. M/C shorts

NO. 5 SHEET.

66,530 8/4" x 12/16 ft. M/C sidings
5,762 5/4" x 4 1/2" x 6/11 ft. M/C shorts
33,627 8/4" x 4 1/2" x 6/11 ft. M/C shorts
10,746 4 1/4" x 8" up x 6/11 ft. M/C shorts
46,630 4 1/4" x 6/11 ft. S/C shorts
14,574 4 1/4" x 6/11 ft. S/C shorts
1,218 6/4" x 6/11 ft. S/C shorts
4,680 8/4" x 6/11 ft. S/C shorts
4,317 6/4" x 12/16 ft. S/C strips

NO. 6 SHEET.

1,456 1" x 4 1/2" x 6/11 ft. M/C shorts
7,194 1 1/2" x 4 1/2" x 6/11 ft. M/C shorts
1,104 1 1/2" x 4 1/2" up x 6/11 ft. M/C shorts
13,804 1" x 8" up x 6/11 ft. M/C sidings
4,310 1 1/2" x 4 1/2" x 12/16 ft. M/C strips
9,373 1" x 8" up x 12/16 ft. M/C sidings
161,856 1" x 4" up x 6/11 ft. S/C shorts
21,719 1 1/2" x 4" up x 6/11 ft. S/C shorts
2,438 1 1/2" x 4" up x 6/11 ft. S/C shorts
3,016 1" x 4 1/2" x 12/16 ft. S/C strips
25,703 1 1/2" x 4 1/2" x 12/16 ft. M/C stocks
11,795 1" x 9" x 12/16 ft. M/C stocks

NO. 7 SHEET.

200,000 1" x 4 1/2" x 12/16 ft. second strips

NO. 8 SHEET.

147,913 1 1/2" x 12/16 ft. S/C sidings
297,073 1" x 12/16 ft. S/C sidings
217,932 1" x 10" x 12/16 ft. good
54,295 1" x 11" up x 12/16 ft. good
33,948 1" x 12/16 ft. second strips.

A. F. BURY AUSTIN,
Wholesale Lumber & Timber Merchant
Montreal.

WANTED—A SAWYER WHO CAN FILE and fit his own saws, for small mill in Assinaboia, N. W. T. Apply in first instance to Box 37, CANADA LUMBERMAN, Toronto.

FOR SALE — 500 ACRES OF STANDING timber in North Hastings, comprising soft elm, ash, basswood, hard maple, cedar, hemlock, etc. Estimated to cut about two million feet, board measure. Will sell cheap for cash. Easy to log and a railway close by. Apply Box 111, CANADA LUMBERMAN.

FOR SALE

30 M. FEET 8/4" SOFT ELM GOOD STOCK.
40 M. feet 6/4" Soft Elm 1st and 2nd.
10 M. feet 1" Soft Elm Common.
Address D. M. BOWMAN, Box 114, Floradale, Ontario.

60,000 Acres of Choice Timber Land

in S. E. British Columbia, estimated to contain 500 million feet, on a good river. Will be sold at a low price if disposed of quickly—onethird cash, balance on time. For details apply to Box 308 CANADA LUMBERMAN, Toronto.

WILL SELL FROM THIRTY TO ONE hundred thousand acres of the finest timber lands in the Kootenay, B. C., on the proposed route of the Kootenay Central Ry. now under construction. For milling men, one of the best speculations in British Columbia. For particulars apply "R.L." Box No. 265, Post Office, Fernie, B. C.

TIMBER LIMIT FOR SALE

SPLENDID CEDAR AND HARDWOOD Timber Limit up-to-date mill with gunshot feed, trimmers and other full equipment; sufficient timber to run 10 years; mill now in full operation, located on Georgian Bay; good shipping facilities; output practically sold for several years. Box 230, CANADA LUMBERMAN, Toronto.



Sale of Burnt Timber

A quantity of pine timber on what is known as Berth B.1, containing 21 square miles more or less, situated South of Woman River Station on the Canadian Pacific Railway 120 miles west of Sudbury, in the district of Algoma, having been damaged by fire, the undersigned hereby calls for tenders for the right to cut same.

Tenders will be received up to and including the 30th day of September next, and must state the rate per thousand feet board measure, including dues, which the tenderer is prepared to pay for the timber, or per thousand feet cubic for whatever proportion of it may be manufactured into waney or square timber, including dues. The timber to be cut during the present winter. Tenders to be accompanied by a marked cheque for \$500.00 payable to the Honourable the Treasurer of Ontario. The timber to be sold subject to the Crown Timber Regulations except where varied by the conditions of this sale. The party awarded the right to cut will be required to give a bond with satisfactory sureties for the payment of the price and the due performance of all terms and conditions required by this Department.

The Department does not bind itself to accept the highest or any tender.
Tenders to be marked "Tenders for Burnt Timber," and addressed to the Honourable the Minister of Lands and Mines, Toronto.

F. COCHRANE,
Minister of Lands and Mines.

Department of Lands and Mines,
Woods and Forests Branch,
Toronto, 21st of August, 1905.

N.B.—No unauthorized publication of this Notice will be paid for.

WANTED—TWO MILLION SPRUCE LATH, f o b. New York, via boat or rail. P. V. LAND, 345 Lenox Ave., New York, N. Y.

FOR SALE—SAW AND STAVE MILL IN Western Ontario. Can be seen in operation now. Must be sold at once, to close an estate. Box 306, CANADA LUMBERMAN, Toronto.

Lumber

We have about two million feet of this season's cut for sale—about 75 per cent. White Pine, balance Norway and Spruce. Address

ERRINGTON & ROSS,
Turbine, Ont.

CURRENT TRADE CONDITIONS.

ONTARIO.

The lumber trade enters upon the month of September with bright prospects. Business is good, and there is every indication of a steady increase in the demand during the next two months. Offerings of white pine are not large, for manufacturers realize that the situation is a strong one and that there is little probability of prices declining very much from the present basis. Building operations continue to consume large quantities of lumber, thus keeping the retailers constantly in the market in order that their stocks may not become too badly broken. From August 16 to August 25 the building permits issued in Toronto represented an expenditure of upwards of \$280,000. Many of the structures which were started in the early spring are now nearing completion, which is reflected in an increased call for finishing material. So far this does not seem to have greatly benefitted the hardwoods, which, while steady in price, are not moving as briskly as pine and hemlock. There is, however, a very hopeful feeling even among the hardwood manufacturers, and more activity is likely to be seen before many weeks. Maple and birch flooring is in good demand and prices are firmer than earlier in the year, due, in part at least, to the higher prices prevailing in the United States.

MANITOBA AND BRITISH COLUMBIA.

Two factors closely affecting the prosperity of the Northwest have, during the past week, made very satisfactory advancement towards becoming a reality. One of these is the safe garnering of the largest yield of wheat which this rich country has yet produced, estimates ranging as high as one hundred million bushels;

the other is the awarding of the contract for the construction of nearly three hundred miles of the Grand Trunk Pacific Railway from Portage la Prairie westward. What a production of one hundred million bushels of wheat means to the Northwest is not easily overestimated—a monetary value of perhaps \$70,000,000. The expenditure for the section of the Grand Trunk Pacific mentioned above will probably be \$4,000,000, and it is gratifying to learn that the contractors are to commence work immediately. This undertaking will have an important influence on commercial activity in Canada, and especially in the West. The lumber trade will be greatly benefitted, for large quantities of timber will be used in construction. The present demand for lumber is active, dealers are busy and most of the mills are operating to their full capacity. Keen interest is shown in the meeting of British Columbia manufacturers to be held shortly for the purpose of adjusting lumber prices and endeavoring to agree upon a basis which will give the producer a fair profit.

UNITED STATES.

Salesmen who are on the road are not finding it difficult to sell lumber; the demand is quite strong and prices firm. Offers below the market are very seldom made, for the buyer knows about as well as anyone that conditions are of the most healthy character and that there is no reason why the seller should make any concession of importance. The wheat crop has been harvested and the weather has been most favorable for the growing of corn. In addition to this feature, the iron and steel industry is enjoying a period of great prosperity. A heavy consumption of lumber during the balance of the year is indicated and prices are very likely to seek a higher level. The northern pine production in the lake region from Duluth to Saginaw has been practically disposed of and is now in the hands of dealers. The scarcity of the lower grades has turned attention to the better qualities, which are already reported to be getting scarce at Buffalo and Tonawanda. Hemlock lumber is doing better than in any previous season, large quantities of dimension and coarse inch going into consump-

tion for building purposes. In Pennsylvania the demand is so strong that another advance of one dollar is contemplated. Spruce continues to advance in price. Ordinary frames are being sold at \$23.50 on Boston rate of freight, and 10 inch random at \$26. The tendency is distinctly upward. The demand for pulp wood is an influential factor in the spruce market and large areas of standing timber have been acquired by the pulp manufacturers.

The two best sellers among the hardwoods are oak and birch. The latter is steadily coming into prominence for interior finish and is now being used to some extent instead of oak. Basswood continues to show weakness. Lath still exhibits remarkable strength. Wisconsin Valley manufacturers are now quoting No. 1 white pine at \$4.25.

GREAT BRITAIN.

Recent views expressed by British importers are of a more optimistic character and in general business there has been a slight improvement. The textile industries are gradually getting into better shape and this will sooner or later benefit the lumber trade. Reports are current of contracts closed with leading importers and it seems to be generally believed that shippers have given a very slight concession. A dealer who recently returned from Canada speaks very hopefully of the spruce market, which he expects to recover materially before the end of the year. A few sales of 3x9 third and fourth qualities have been made at £8 10s. and £8 per standard respectively c.i.f. London. The stock of spruce in Liverpool is not very large and is not likely to be greatly increased during the balance of the season. At Cardiff, Hull and other ports stocks are below the average, which will give the seller a decided advantage when the market becomes more active. There is a good demand for battens and small boards. A Hull correspondent states that Quebec pine has advanced 10s. per standard, second quality now being quoted at £21.

A saw mill at Waterford, Ont., owned by Richard Robinson, was burned a few days ago.

STOCKS AND PRICES.

Wm. Cowan & Co.'s saw mills, Prince Albert, N.W.T., closed down last week, having exhausted their supply of logs.

Donald Fraser & Sons, of Fredericton, N.B., whose Aberdeen mill was burned recently, have arranged to have their logs sawn at the Warner mills, St. John.

Pine piece stuff in Chicago is up \$1, joists 50 cents to \$1.50, timber \$1 to \$2, common boards \$1, stock boards 50 cents to \$1. Good lumber is up \$2 to \$5, and on 1½ to 3-inch uppers \$8 more is asked.

The Pigeon River Lumber Company, Port Arthur, Ont., recently shipped a cargo comprising 700,000 feet of lumber to Saginaw, Mich. This is the first cargo that has been shipped from Port Arthur to an American port for several years.

Messrs. Clairmonte, Man & Company, Barbados, say of the lumber market: There have been two arrivals with lumber during the fortnight. The demand for both white pine and spruce has fallen off. Last sale of white pine on the spot was at \$22.60 per M for merchantable and \$16.00 for second quality. Last sale of spruce on the spot was \$21.00 per M for merchantable, and \$15.00 for second quality.

The following is the probable cut this season of several of the large Georgian Bay firms: Loveland & Stone, Cutler, 30,000,000 feet; Moulthrop Lumber Company, Johns Island, 20,000,000 feet; Eddy Bros. & Company, Blind River, 20,000,000 feet; S. O. Fisher, Blind River, 15,000,000 feet; McArthur Bros. Company, Little Current, 25,000,000; T. G. Burtis, Thessalon, 20,000,000 feet; Holland & Graves, Byng Inlet, 38,000,000 feet.

CANADIAN LUMBER SHIPMENTS.

From Halifax, N. S.: Barque Federal, for Port Talbot, G. B., 244,386 ft. birch deals, value \$4,112; 374,405 ft. spruce deals, value \$7,045, by W.M. McKay, agent.

From St. John, N.B.: Steamer Micmac, for Belfast, 1,002,654 ft. deals and battens, 34,394 ft. scantling, 39,479 ft. boards, 41,974 ft. ends. Schooner H.M. Stanley, for Boston, 98,791 ft. plank, 42,939 ft. scant-

ling. Schooner Comrade, for Scituate, 931,070 shingles. Schooner Abana, for Bridgeport, 61,305 ft. spruce boards, 46,481 ft. scantling, 16,936 ft. plank. Schooner Otis Miller, for City Island, 160,488 ft. deals, 1,043 ft. plank. Schooner Georgia E., for Stonington, 14,925 ft. plank, 71,088 ft. boards, 100,000 laths, 228,420 shingles. Steamer Phoenix, for Brow Head, 1,266,937 ft. deals and battens, 92,849 ft. scantling, 70,900 ft. ends, 151,556 ft. boards, 25,259 ft. birch plank, 1,933 ft. birch scantling, 2,607 ft. birch ends, 1,076 ft. boards.

From Montreal: Steamer Virginian, for Liverpool, 7,322 pcs. deals, 134 pcs. timber. Steamer Milwaukee, for Liverpool, 4,834 bds. lumber, 1,400 pcs. boards, 934 bds. maple flooring, 3,093 pcs. lumber, 5,716 pcs. board tops, 96 logs, 1,111 bds. shooks, 23,556 pcs. deals. Steamer Dominion, for Liverpool, 25,180 pcs. deals. Steamer Pomeranian, for London, 3,706 pcs. deals. For Havre, 57 logs, 1,946 pcs. lumber. Steamer Monmouth, for London, 1,863 pcs. lumber, 285 bds. lumber, 4,441

W. C. CRAWFORD

Tilbury Ont.

Manufacturer of . . .

Handles—Axe, Fork, Pick, Etc.

Also Hard and Soft Wood Heading and Red and White Oak, Maple and Elm Lumber.

Can supply Second Growth White or Red Oak squares up to 38 in. long in large quantities.

A SPLENDID ROUTE.

The Wisconsin Central Railway is justly termed the "Sportman's Line" because it reaches into and through the very heart of the choicest hunting grounds in America.

The very best wild fowl shooting of the entire North is reached ONLY by this line. Hundreds of beautiful lakes abounding in wild rice and celery attracts myriads of ducks and geese and afford the finest kind of cover and the choicest shooting to be found the country over.

The Wisconsin Central Railway caters especially to the sporting public and during the various seasons for hunting and fishing furnishes daily information to its patrons as to local conditions anywhere along its lines upon application to the nearest ticket agent. It also arranges its train service with special reference to the convenience and comfort of sportsmen, and its employees are constantly on the alert to make travel over their lines pleasant and comfortable.

This line offers the best route between Chicago, St. Paul, Milwaukee, Minneapolis or to Lake Superior points via Ashland, Wisconsin. Information given by addressing—

JAS. C. POND, Wis. Cent. R. R. Milwaukee.

WOODS & SPICER, Limited

.....MANUFACTURERS OF.....

BRITISH COLUMBIA RED CEDAR SHINGLES

Capacity 100 Million a Year.

We have had over 15 Years Experience, and are not Asking our Competitors for any Pointers as to Quality.

Wire Your Orders at OUR EXPENSE to Agents, or to us at VANCOUVER, B. C.

KNIGHT BROTHERS CO. LIMITED
Burk's Falls, Ont.

KILN-DRIED BIRCH FLOORING

Send for Catalogue
or Samples by Mail

KNIGHT BROTHERS CO. LIMITED
Burk's Falls.

Keenan Bros., Limited

Owen Sound, Ont.

HARDWOOD, HEMLOCK AND PINE LUMBER

We carry a full supply of native Hardwoods always on hand and solicit your inquiries. At the present time we have piled at outside points about 2,000,000 feet of Hardwoods, and about the same quantity of Hardwood, Hemlock and Pine piled here in Owen Sound, and we should be able to interest you if in the market.

WILL MAKE SPECIAL PRICES ON
BROKEN LOTS AT OUTSIDE POINTS

Planing and Matching

—IN TRANSIT—

S. POMEROY, Orillia

PLANING, MATCHING, RESAWING,
SIDING, FLOORING, MOULDINGS
in Car Lots.

Factory near Station. Write for Prices
Phone 113

MASON, GORDON & CO.

WHOLESALE TIMBER

Montreal, Quebec

Eastern Agents The B. C. Mills, Timber & Trading Co., Vancouver, B. C.
DOUGLAS FIR Timber in any size or length supplied
WRITE FOR PARTICULARS AND QUOTATIONS.

EVERYTHING IN LUMBER AND TIMBER
DRESSED AND IN THE ROUGH

THE M'LENNAN LUMBER CO., LIMITED

MONTREAL QUE.

Office and Yard, 571 DORCHESTER ST.

P.O. Box 116

pcs. birch lumber, 36,160 pcs. boards, deals and ends, 17,890 bdls. shooks. Steamer Iona, for London, 5 pcs. doors, 1,063 pcs. lumber. Steamer Mauxman, for Bristol, 4,289 pcs. boards, 2,758 pcs. deals. Steamer Sicilian, for Glasgow, 3,765 pcs. deals, 381 logs, 2,232 pcs. boards. Steamer Athenia, for Glasgow, 393 pcs. deals. Steamer Tampican, for Newcastle, 54 pcs. lumber, 21,142 pcs. boards and deals. Steamer Oriana, for Port Natal, South Africa, 9,614 pcs. lumber, 917 bdls. lumber, 5,174 pcs. boards, 900 bdls. doors, 50 bdls. windows. For Algoa Bay, 369 pcs. boards, 670 pkgs. boards, 488 pcs. lumber, 126 bdls. doors. For Cape Town, 17,517 pcs. lumber, 28 bdls. lumber, 2,898 bdls. staves, 12 pcs. boards, 983 pcs. boards, 200 pcs. deals, 1,200 doors. For East London, 1,805 pcs. lumber, 86 bdls. lumber, 49 pkgs. boards, 1,563 pcs. boards, 491 doors.

TIMBER LIMIT TRANSACTIONS.

It is announced that the Bayless Pulp and Paper Company, of Binghampton, N.Y., has concluded a deal whereby it comes in possession of three hundred square miles of spruce timber on the River St. Anne, province of Quebec. The purchase was made of the Seminary of Quebec, an old Catholic institution, and the amount paid was one million dollars. The Seminary of Quebec received its charter from the King of France and it was later confirmed by the English. The deal has been progressing for some time, and it is announced that the syndicate will establish mammoth paper and pulp mills

in the vicinity, and use the timber in making wood pulp.

James C. Wright sold at auction at Hopewell Hill, N.B., on August 18th, his 800 acres of timber land—with saw mill—and the standing timber on a fifty-acre lot adjoining, the buyer being Warren Downey, of Cape Station, who secured the property for \$16,050. The property is situated at Memel, four miles from Hopewell Hill. The general impression is that it sold well.

On some date on or between September 15th and 20th the transfer of 166,000 acres of timber land, mills, etc., from the William Richards Company, of Chatham, N.B., to the International Paper Company, of New York, will be made. So far as can be learned the price to be paid will be between \$600,000 and \$750,000. The property which the Americans are purchasing gives them control of all of the Richards Company's business on the Miramichi, and they will therefore retain their mill property at Campbellton. The property to change hands includes 166,000 acres of timber land on the Taxis river, the Richards Company's mills at Boies-town and Chatham, and lumbering equipment.

The Wolverine Land & Lumber Company, of Menominee, Mich., are said to be negotiating for the Eddy-Glynn tract of timber land on the Whitefish and Spanish rivers, containing about 100,000,000 feet of pine. Cruisers recently went over the territory on their behalf.

Several Duluth lumbermen, including

John McAlpine, Henry Turrish, W. H. Cook, William O'Brien and the Lambers Bros., of Stillwater, are said to have recently disposed of some 260,000,000 feet of pine timber, situated north of Pelican Lake, to the Weyerhaeuser interests. The price is understood to have been about \$7 per thousand.

DEMAND FOR BOX SHOOKS.

Mr. G. Eustace Burke, Canadian commercial agent in Jamaica, writes to the Trade and Commerce Department urging lumbermen in Canada to try to catch the orders for orange and pineapple box shooks, which are needed in great quantities in the southern island. The orange season will shortly be in full swing and the demand will be very active. So far the United States shippers have been able to place their goods almost exclusively.

McNutt's saw mill at Tay Creek, N.B., was destroyed by fire recently, the loss being about \$4,000.

The box factory of the London Box Manufacturing & Lumber Company, London, Ont., was destroyed by fire last week, the loss being about \$35,000. F.G. Rumball is heavily interested.

A dispatch from Quebec states that the saw mills and lumber yard of Price Bros. & Company at Metabetchouan, Que., was burned on the 26th inst. The loss, about \$40,000, is said to be fully covered by insurance.

The saw mill of the Newville Lumber Company, Newville, N.S., with over a million feet of lumber, was destroyed by fire on August 26th. The loss will be in

the vicinity of \$59,000, about half of which is covered by insurance.

L. Dean Holden, Pres. J. M. Diver, Gen'l.-Mgr. F. A. Holden, Vice-Pres. E. C. Barre, Ass't Mgr.

The Cleveland-Sarnia Saw Mills Co., Limited.

Manufacturers and Wholesale Dealers in

Timber, Lumber, Lath and White Pine Shingles

Special Bills Cut to Order in White Pine, Norway and Fir, any length from 10' to 60' long.

SARNIA, ONT.

M. & L. Samuel, Benjamin & Co.

503 Temple Building, Toronto.

EXPORT DEPARTMENT.

Correspondence solicited with exporters of wooden goods, such as Sanitary Woodenware, Broom Handles, Fork and Shovel Handles, Turned Goods, etc. Payments made on receipt of Bill of Lading at Toronto. European House, SAMUEL SONS & BENJAMIN, 16 Philpot Lane, London, Eng.

J. B. Farwell & Son
CONTRACTORS AND DEALERS IN ..

Canadian Cedar Telegraph, Telephone and Electric Light Poles

Bancroft, Ont., and Oswego, N.Y.

ARTHUR A. WATT
WIARTON, ONT.

Dealer in Hard and Soft Wood, Lumber, Lath, Shingles, Cedar Posts and Tiles

SPECIAL—50,000 4/4, 8/4 and 12/4 Soft Elm 30,000 3/4 Maple, C & B; 18,000 4/4 Soft Maple 100,000 4/4 M. R. Basswood; 18,000 4/4 Mill Run Pine Sidings, 40,000 4/4 and 8/4 Birch; 40,000 6/4 Beech. Prices on application

THE KING AND BARTLES LUMBER CO.
PINE, POPLAR AND HARDWOODS

HEADQUARTERS: Citizens' Building, Cleveland, O.
HARDWOOD: Distributing Yard, McMinnville, Tenn.
We buy and sell Pine in Car and Cargo Lots

BANK ST. CHAMBERS

OTTAWA, ONTARIO

W. B. BARTRAM

WHOLESALE LUMBER AND TIMBER MERCHANT

White Pine, Quebec Spruce and Hardwood.

Special Bills sawn on short notice. Barge or car load lots

All Inquiries Given Prompt Attention.

J. GORDON MACLAREN

HINTONBURG, ONT.

DIMENSION TIMBER { In Spruce, White and Red Pine, up to 40 feet.
In Douglas Fir, up to 90 feet.

Every Inquiry receives our Prompt attention.

Write for quotations. B. C. Cedar Shingles

SASH - DOORS - BLINDS

Please mention this paper when corresponding with advertisers.

CARTER POWELL LAND & LUMBER CO., LIMITED

604 Temple Building, Toronto

To **MILLMEN**—Cash buyers all kinds **HARDWOODS**

Cable address "Quartered Toronto." Codes, A. B. C., 5th and Lumberman's

THE IMPERIAL LUMBER CO., LIMITED

SAW AND PLANING MILLS, WARREN, ONT.

RED AND WHITE PINE DEALS

All kinds of **SAWN LUMBER** by Carload or Cargo.

BRANCH OFFICE, MANCHESTER, ENG.

Head Office, **TORONTO, CAN.**

Registered Cable Address, "Pinewood." "American Lumberman" Telecode.

B. C. RED CEDAR SHINGLES

Several cars now in transit, hence can give prompt delivery.

SEND IN YOUR ORDERS

C. A. LARKIN - - Toronto

J. D. SHIER LUMBER CO., LIMITED
BRACEBRIDGE, ONT.

MANUFACTURERS OF **LUMBER, LATH AND SHINGLES**

Pine, Hardwood and Hemlock Floorings and Ceilings. Sash and Doors, Wood Turnings etc. All Dressed Lumber Kiln Dried if desired End Matched Flooring a Specialty.

GOOD PINE SIDINGS A SPECIALTY

Planing, Matching, Resawing, etc. In Car Lots.

Manufacturer of **Doors, Sash, Mouldings, Ceilings** End-Matched and Bored **HARDWOOD FLOORING** A SPECIALTY.

Lumber Kiln Dried in Any Quantity.

J. R. EATON - Orillia, Ont.

Correspondence Solicited. Phone No. 54.

CEDAR POLES

5,000 pieces, 10 to 20' long. Suitable for Hops, etc. Price?—We'll write us.

THE LONG LUMBER COMPANY
HAMILTON

CACHE BAY LUMBER INDUSTRIES.

Geo. Gordon & Co.,
Manufacturers of RED and WHITE PINE

Band - Gang **LUMBER**
Circular

CACHE BAY, Ont. C. P. R. 26 miles West North Bay **AND LATH**

BRITISH COLUMBIA OPERATIONS.

The Bowman Lumber Company, of Revelstoke, have two logging camps and two logging engines at work on Fish Creek, delivering 120,000 to 150,000 feet a day.

Some Duluth capitalists, represented by Dr. Cook and others, were at Grand Forks, B.C., recently negotiating for the purchase of some 25 square miles of timber limits up the North Fork of the Kettle River. They have a cruiser with them for the purpose of cruising the timber. Should the deal go through, Dr. Cook and his associates will erect a large mill and find a market in the new places that are opening along the Kettle River in Nicola Valley.

The Kendall Logging Company, which has been working at Comox, has suspended operations. The men who were working for the company have put in their claims, which amount to \$1,900, the logs seized being worth approximately \$2,100. The engine, which was only partially paid for, has been taken back by the Chemaius Lumber Company, who had a lien on it, and the E. K. Wood Company, of Bellingham, are said to have a chattel mortgage on the rest of the logging outfit. The company operated on limits owned by the E. K. Wood Company. There are other creditors, but for what amounts has not been learned.

A Vancouver paper recently contained an announcement concerning the taxation of timber lands. It read: "Notices are being issued calling upon the holders of all timber under license to furnish returns as to the value set upon their timber to the tax collectors and assessors. Failing such returns the tax collectors are empowered to

assess the values themselves and levy the tax accordingly. It is estimated that there will be raised by this means a revenue of \$400,000." The above notice was somewhat misleading, and was further explained by the publication of the following: "We are informed that there are no notices being sent out by the assessor to the holders of licenses of timber lands, because timber lands held under lease or license are exempt from taxation by the act. What is being done, however, is that a form is being sent out to the owners of timber land to be filled up in accordance with the Act, showing the description, value and other particulars of the land they claim to be timber land, so that the assessor may know whether to assess it 2 per cent. as timber land or 4 per cent. as wild land. This form is being sent out in the ordinary course of the assessor's duties in preparation of the roll for 1906, and none are sent to the lessees or licensees of provincial timber lands."

BUSINESS NOTES.

A demand of assignment is reported to have been made upon Isreal Nantel, lumber dealer, Montreal.

David R. Galbraith, lumber manufacturer, Mar, Ont., is announced to have assigned to D. R. Jermyn.

The W. F. Hunting Lumber Company, Vancouver, B.C., report very good business in shingles this summer. They are running night and day.

The Liverpool firm of R. Parker & Company, Limited, in liquidation, has managed to pay no less than 15s 4½d on the pound, a result which will be very satisfactory to all concerned, including the directors.

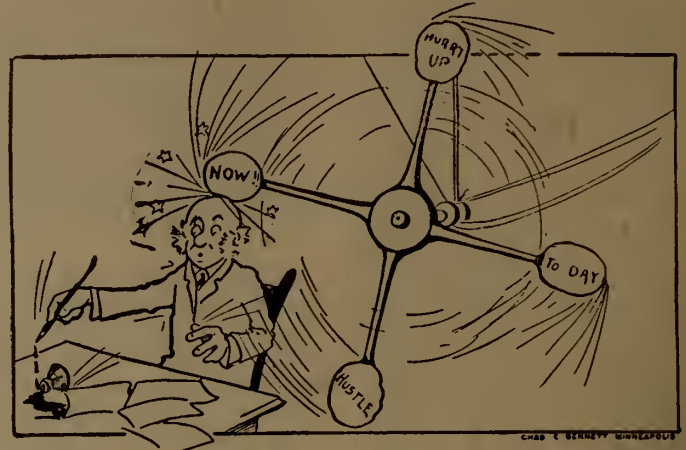

JUST A GENTLE REMINDER

That's all--a reminder that we can supply your wants in the lumber line. It's up to you NOW to realize that fact and to open up correspondence with us. Don't forget that SPRUCE LUMBER is our specialty—and should be yours. Let us tell you why.

The Red Deer Lumber Company
WINNIPEG, MAN.

UNITED STATES MANUFACTURERS AND WHOLESALERS

**YOU
CAN
REACH**

THE BONSAK LUMBER CO.
WHOLESALE HARDWOODS

ST. LOUIS
BY
RAIL, MAIL
WIRE OR
'PHONE

YELLOW PINE

We are in position to give first - class stock. Reasonable prices. Prompt shipments. Mills in Alabama, Mississippi and Arkansas.

MANN, WATSON & CO. Muskegon, Mich.

H. D. WIGGIN BOSTON, MASS.
89 STATE ST.

will inspect at mill and PAY CASH for

LOG RUN

Elm, Ash, Bass and other Hardwood

CORRESPONDENCE SOLICITED.

Is it your wish . . .

To Purchase or Sell as quickly as possible
A PARTICULAR LOT OF LUMBER
A MILL PROPERTY
SECOND-HAND MACHINERY

An Advertisement in the "Wanted" And "For Sale" Department of the

CANADA LUMBERMAN WEEKLY EDITION

Will secure for you a Buyer or Seller, as the case may be. Address: The Canada Lumberman, Toronto

THE ROBERT H. JENKS LUMBER CO.
CLEVELAND, OHIO

MANUFACTURERS AND WHOLESALERS OF

YELLOW PINE, POPLAR, HEMLOCK AND HARDWOODS

Yellow Pine Timbers a Specialty

Indiana Lumber & Veneer Co.
INDIANAPOLIS, IND.

Sawed and Sliced Quartered
Oak a Specialty

Correspondence Solicited. <<<<<

Veneers

McGLURE LUMBER CO.

Wholesale Dealers in . . .

Hardwood Lumber

Carry in Stock and Have for Sale

ASH, BASSWOOD, BEECH, BIRCH, BUTTERNUT, CHERRY, CHESTNUT, COTTONWOOD, CYPRESS, ELM, GUM, HICKORY, MAHOGANY, MAPLE, OAK, POPLAR, SYCAMORE, WALNUT, POLES (Oak, Hickory and Ash), RIMS and SPOKES (Oak and Hickory), OAK BENDING PLANK, OAK BILL STUFF, RAILWAY TIES.

Office and Yards: 520 to 530 Franklin St., DETROIT, MICH.

Correspondence Invited on All Hardwoods.

FRANK C. BURY

BURY & NOBLE

MASON A. NOBLE

WHOLESALE

LUMBER - DETROIT

MICHIGAN

Send us your inquiries for Southern Yellow Pine.

CANADIAN MANUFACTURERS and WHOLESALERS

THE PEMBROKE LUMBER CO.

PEMBROKE, ONT.

We make a specialty of Dimension Stock in Pine, Spruce and Hemlock, and solicit your enquiries.

ALBERT J. DELAPLANTE

WHOLESALE

Pine, Hemlock, Lath, Shingles, Etc.

Office: 503 Manning Chambers - - - TORONTO

FOR Pine, Hemlock, or Hardwood, Lumber and Timber, Telegraph Poles, Ties, Posts, Lath, Shingles, Dressed Lumber, Sash, Doors, Interior Finish, End Matched and Bored Hardwood Flooring, etc., try

JOHN HARRISON & SONS COMPANY, LIMITED

We have a complete stock, two Saw Mills running in summer and one all winter. HEAD OFFICE, SAW AND PLANING MILLS, OWEN SOUND, ONT.

RHODES, CURRY & CO., Limited LUMBER MERCHANTS.

Yards at Amherst, Little Forks, Sydney and Halifax.

BUILDING MATERIAL of all kinds carried in stock. We are buyers of Ontario Basswood, Elm and Pine.

Amherst, N.S.

Sawn and Hewn Spruce, Hemlock, Pine and Birch Timber, Spruce and Pine Boards and Plank, Birch and Ash Boards and Plank, Flooring, Shingles, etc.

JAMES J. MURPHY, Bank of Hochelaga Building QUEBEC

F. MCGIBBON & SONS, PENETANGUISHENE ONT.

Manufacturers of Pine, Hemlock and Hardwood Lumber, and dealers in Cordwood Hemlock Bills cut on short notice.

The Cook & Bros. Lumber Co. MANUFACTURERS OF

Of Ontario, Limited

MILLS at SPRAGGE, Algoma Dist., Ont. on "Soo" Branch C. P. R.

OFFICES: Manning Arcade, Toronto Coristine Building, Montreal And at Mills at Spragge.

White and Red Pine Lumber and Lath

Water Shipments

THE M. BRENNEN & SONS MANUFACTURING CO., LIMITED

Saw Mills at RAINY LAKE, Ontario. Planing Mill and Head Office: HAMILTON, Ontario.

THE NIPISSING LUMBER COMPANY, LIMITED

Mills at CACHE BAY and SPANISH RIVER, Ontario.

Manufacturers of and Wholesale Dealers in all kinds of LUMBER AND LATH

Both Railway Delivery and Water Shipments. Correspondence Solicited. The NIPISSING LUMBER CO., Limited Head Office: HAMILTON ONT.

A. F. BURY AUSTIN WHOLESALE LUMBER and TIMBER CANADA PINE

Bank of Ottawa Building, 224 St. James St., - MONTREAL, CANADA SPECIALTIES: Railway Bridge Timber and all kinds of Hardwoods; Ship Decking, Norway and White Pine, Dimension Timber, Norway Car Sills, Car Flooring, Telegraph Poles, Railway Ties, Oak and Whitewood, Planed and Rough Lumber, British Columbia Pine, Southern Pine, &c.; Birch Flooring, hollow back, end butted.

Eastern Agent for The Pacific Coast Lumber Company, Limited, Vancouver, B. C. Douglas Fir Timber in any size or length up to 90 feet long. Timber Planers face up to 24 inch x 30 inch. Dry Kilns of large capacity. Rough and Dressed Lumber, Douglas Fir and Cedar.

WRITE FOR PARTICULARS AND QUOTATIONS.

R. LAIDLAW LUMBER CO.

18 Toronto Street, Toronto

JAS. PLAYFAIR.

D. L. WHITE

PLAYFAIR & WHITE

Manufacturers and Wholesale Dealers

LUMBER • LATH • SHINGLES

Contractors for Railway Supplies BILL TIMBER a Specialty

MIDLAND, ONT

A. & P. WAIGE

Manufacturers of and Dealers in

Sawn and Planed Lumber, Dimension Timber. Joisting Car Sills, Car Flooring, Shingles and Lath.

PEMBROKE ONT.

GET YOUR LUMBER AND TIMBER FROM

PINE LUMBER COMPANY

(On C. P. R. Main line near Sudbury)

PINE, ONT.

MAITLAND, RIXON & CO. OWEN SOUND, ONTARIO.

Manufacturers and Dealers

LUMBER LATH, TIES, POLES, SHINGLES, ETC.

Make a Specialty of Long Pine, Cedar and Hemlock Bill Stuff. We ship by C. P. R., G. T. R., and by Water.

Turner Lumber Co., Limited

MANUFACTURERS

LUMBER and LATH

Shipments by Rail or Water.

Midland, Ont.

HARDWOOD FLOORING

End Matched, Bored, Steel Polished, and Bundled

Send for Price List

A few cars of selected Maple and Birch and other Hardwoods at close price

THE SEAMAN KENT CO., Limited

160 Bay St. Toronto

Factory, Meaford, Ont.

THE FOSS LUMBER COMPANY

WHOLESALE

BRITISH COLUMBIA FIR, SPRUCE AND

CEDAR LUMBER, RED CEDAR SHINGLES

We Solicit Your Inquiries.

J. F. FOSS, Manager.

624-625 Union Bank, Winnipeg, Man.

HARDWOOD FLOORING

MANUFACTURED IN

MAPLE, BIRCH, BEECH AND OAK

3/8, 1/2, 3/4, 1 and 1 1/2 inch thicknesses. Kiln-Dried, Hollow Backed, End Matched, Bored and Polished, bundled with wire baling. . . .

Also Stock fully machined for Spring Bed Frames

and

ALL KINDS OF HARDWOOD LUMBER

J. S. FINDLAY

OWEN SOUND, ONT.

AUGER & SON

We Buy, Sell and Deal in all kinds of Lumber and Timber in Canada and United States: Spruce, White Pine, White and Basswood, Ash, Cedar, Douglas Fir, Beech, Birch, Walnut, Cherry, Chestnut, Cottonwood, Hemlock, Maple, Norway Pine, Short and Long Leaf Yellow Pine, Oak, Redwood, Birch, Maple and Oak Floorings, Pulpwood, Ties and Cedar Poles.

Quebec

Cedar Cove Mill,
Vancouver, B.C.

E. H. HEAPS & CO.,
Vancouver, B. C.

Ruskin Mill
Ruskin, B. C.

Lumber, Lath, Shingles, Doors, Mouldings, Etc.

SPECIALTIES :

AA1 HIGH GRADE CEDAR SHINGLES.

Cedar Bevelled Siding, Cedar Door and Sash Stock, cut to size, Cedar Finish, Base, Casing, Newels, Balusters, etc. Douglas Fir Timber up to 85 feet in length.

W. J. SHEPPARD PRESIDENT
Waubaushene, Ont.

J. G. SCOTT, GENERAL MANAGER
Vancouver, B.C.

Pacific Coast Lumber Co.

LIMITED
VANCOUVER, B.C.
MANUFACTURERS OF

**Fir, Cedar and Spruce Lumber, Lath, Mouldings, Turned Work, Etc.
High Grade Red Cedar Shingles**

Ontario Representative, W. J. LOVERING,

112 Mail Building, TORONTO

D. C. CAMERO President and Manager.

WM. ROBERTSON, Secretary.

J. E. YOUNG, Cashier

The Rat Portage Lumber Co., Ltd.

Manufacturers
of

**White and Red Pine Lumber, Lath, Shingles, Sash,
Doors, Turned and Band Saw Work**

Dealers in CEDAR POSTS, POLES and TAMARAC PILING

Mills at RAT PORTAGE and RAINY RIVER, Ontario, WINNIPEG, Manitoba, and VANCOUVER, British Columbia. Head Office: RAT PORTAGE, Ontario

Our Vancouver Mill cuts High-Grade Cedar, Fir, Spruce and Red Cedar Shingles. Winnipeg Mills cut Pine, Tamarac and Spruce Lumber
We also Manufacture all kinds of Mouldings, Sash, Doors, Turned Work and Boxes. Correspondence solicited at all four points.

**Export Lumber &
Shingle Co., Limited**
Vancouver, B. C.

We are Exclusive Selling Agents in Canada
for 40 per cent. of the Shingles manufac-
tured in British Columbia. Daily shipping
capacity over 1 1/4 millions.

W. C. WELLS

PALLISER, B. C.

Manufacturer of

**High Grade Spruce, Fir, Cedar
and Lumber of all Descriptions.**

CORRESPONDENCE SOLICITED.

W. B. McKECHNIE, President.

C. MACRAE, Manager.

THE ALBERTA LUMBER CO.
Vancouver, B. C. LIMITED

Manufacturers of

BRITISH COLUMBIA RED CEDAR

All sizes to 24 inches wide, by 24 feet long—CLEAR.
B. C. FIR—DIMENSION AND FINISH.

SCRIBNER'S LUMBER AND LOG BOOK

A handy book for Lumbermen. Gives Correct Measurements
of Scantlings, Boards and Planks; Cubical Contents of Square
and Round Timber; Doyle's Rules, and much other practi-
cal information.

Price 35 Cents

ADDRESS THE CANADA LUMBERMAN, TORONTO, ONT.

1,000,000 Shingles Per Day

About half the B. C. Shingles used in Canada are sold by us. Our Daily Shipping Capacity is over One Million Shingles.

LUMBER

DOUGLAS FIR, SPRUCE and CEDAR
Fir and Cedar Lath

DOORS, WINDOWS, MOULDINGS, NEWELS, BRACKETS, BALUSTERS and all descriptions of INSIDE and OUTSIDE FINISH

P. O. Box 407 **UNION LUMBER COMPANY, Limited** Head Office: 536 Hastings St. Vancouver, B. C.

EMPLOYMENT BUREAU
R. B. ST. GEORGE
RAILWAY, LUMBER and
CONTRACTORS' AGENT
158 Canal St. Russell Block, Ottawa.
Men wanted at all times for Bush and Railroad
Work. Phone 1,950

**McLennan Timber Land and
Lumber Co., Limited**
Selling Agency and Dealers in all
kinds of Timber Lands.
Offices: Quebec, 131 St. Peter St.
Ottawa, Room 9, Central Chambers.

CANADIAN LUMBER WANTED

We solicit consignments of long
and short lumber from the Mari-
time Provinces and are prepared
to purchase White Pine and
Hardwoods in Ontario and Que-
bec.

ADDRESS:
CHAS. S. WENTWORTH & CO.
Room 510, 147 Milk St. - BOSTON, MASS.

HELP

Can be obtained at small cost by
advertising in the Want Columns
of the WEEKLY CANADA LUMBERMAN.

BRITISH WOOD BROKERS AND IMPORTERS

FARNWORTH & JARDIN

Wood Brokers and Measurers

Cable Address "Farnworth," Liverpool. 2 Dale St., 71 Regent Road BOTTLE, LIVERPOOL, ENG.

F. A. Lightbody & Co.

8 Gordon Street - GLASGOW, SCOTLAND

WOOD BROKERS

Cable Address: "TENEBRIS," GLASGOW. Codes: A. B. C., A 1, "Zebra" and Private
Agents for CANADIAN WHITE PINE AND SPRUCE; Hardwoods in Log, Etc.
Shipments handled to the best advantage to all ports in the United Kingdom Correspondence Solicited

LOUIS BAMBERGER,

2 Broad Street Building,
LONDON, E. C.

IMPORTER OF Telegraphic Address "Bellywood, London."

Pine, Spruce and all Canadian Wood Goods

Are Open to Contract for Glued-Up BASSWOOD KEYBOARDS

ZEBRA CODE A. B. C. CODE DIRECTORY CODE

GELLIBRAND, HEYWOOD & CO.

Wood Agents and Brokers

Cable Address: "GELLIGHT," LONDON 57 Gracechurch St. London, E.C. England

FELBER, JUCKER & CO.

Lumber Importers

MANCHESTER ENGLAND
Invite offers from Lumbermen for . . .
Spruce Deals and Battens, Spruce and Pine
Floorings, Shooks, Sashes, Mouldings, Dowels,
Broom Handles, Chair Stock, Seats, etc., or any
Woods Suitable for English Market.
Telegraphic Address: FELBER MANCHESTER.

Cable address: "Dundonian, Dundee."

BERG & SON,

Timber and Wood Pulp
Agents and Brokers

DUNDEE, SCOTLAND

Contracts made between Shippers and Importers
Correspondence solicited

SMITH & TYRER - 14 Tithebarn Street, LIVERPOOL .. WOOD AGENTS ..

Cable Address—"Walmer," Liverpool.
Halifax, N.S., Office—SMITH, TYRER & Co., Metropole Bldg., Hollis St. Halifax, N.S.

Edmiston & Mitchells TIMBER BROKERS

Cable Address: "EDMISTON" Glasgow. 33 Renfield Street, GLASGOW

GANT & KEMP TIMBER BROKERS

52 St. Enoch Square, GLASGOW

Cable Address: "TECTONA" Glasgow.
A 1 and A B C Codes used.

Telegrams and Cables: "Woodfeller, London." Codes: Zebra, Western Union, Southards, and A. B. C. 4th and 5th Editions

THOMPSON, BLOIS & CO.

Buyers of all Kinds of Lumber and Logs

17 GRACECHURCH STREET: LONDON, E. C.

Cash advances made against
shipping documents.

Branches:
MANCHESTER, HAMBURG.

JOSEPH OWEN & SONS, LTD.

Timber Importers

Cable Address "Owen Liverpool" Liverpool, Eng.

BUYERS OF

White Ash Logs and Planks.
Oak Logs and Planks.
Rock Maple Logs and Planks.
Rock Elm Logs.
Hickory Logs.

... ALSO ...

All classes of Lumber and Manufactured
Wood Goods suitable for the English
Market.

JAMES WEBSTER & BROTHER

BOOTLE, LIVERPOOL, ENGLAND

TIMBER MERCHANTS

BUYERS OF Oak, Birch, Ash, Grey Elm Logs and Lumber, Elm
Staves and Heading, Handles of all descriptions
Veneers A Specialty

ALFRED DOBELL & COMPANY WOOD AGENTS AND BROKERS

Liverpool and London Chambers - LIVERPOOL, ENGLAND

CABLE ADDRESS "DOBELL LIVERPOOL"

THE ONTARIO LUMBER CO. LIMITED

MILLS: North Bay, C.P.R. and G.T.R. Delivery.

WHITE PINE LUMBER, LATH AND SHINGLES.

35 and 36 Home Life Building TORONTO, Ont. MILLS: French River, Georgian Bay Water Shipment Only.

PEDWELL & LEMCKE, Lions Head, Ontario

MANUFACTURERS OF Pine, Hemlock and Hardwood Lumber, Shingles, Ties, Poles, Posts, Etc.

Rail or Water Shipments. Correspondence Solicited.

WE have Three Millions of Hemlock, running in lengths from 10 to 24 feet, which we are prepared to cut in blocks of 50,000 feet or over.

THE WOODSTOCK LUMBER & MANUFACTURING CO.

Dealers in Pine, Hemlock and Hardwood Lumber..

WOODSTOCK, ONTARIO

GEO. G. GLADMAN MANUFACTURER OF WHITE PINE AND HEMLOCK LUMBER LATH AND SHINGLES

Mills at Smith's Bay Township of Carling

PARRY SOUND, ONT.

CORRESPONDENCE SOLICITED

A. P. EBERT

MANUFACTURER OF AND DEALER IN

Pine and Hardwood Lumber, Lath, Shingles, Posts, Broom Handles, and Short Hardwood Dimension Stock

WIARTON, ONT.



THE NEW LINE

Through the Spruce Forests of the Laurentian Mountains—between Quebec and Hawkesbury.

WATER-POWERS, TIMBER LIMITS AND ELECTRIC POWER FOR SALE. IDEAL PULP-MILL SITES.

Unexcelled Export Facilities at Quebec.

A. J. GORRIE, General Supt. MONTREAL GUY TOMBS G. P. & P. A.

CURRENT LUMBER PRICES--WHOLESALE

TORONTO, ONT.

CAR OR CARGO LOTS.

Table listing various lumber products like Pine, Hemlock, and Shingles with their respective prices per car or cargo lot.

HARDWOODS--PER M. FEET CAR LOTS.

Table listing hardwood products such as Elm, Rock, Mill, Birch, and Cherry with prices per car lot.

QUEBEC, QUE.

WHITE PINE--IN THE RAFT

Table listing white pine products in the raft with prices per car lot.

RED PINE--IN THE RAFT.

Table listing red pine products in the raft with prices per car lot.

OAK--MICHIGAN AND OHIO.

Table listing oak products from Michigan and Ohio with prices per car lot.

ELM.

Table listing elm products with prices per car lot.

ASH.

Table listing ash products with prices per car lot.

BIRCH.

Table listing birch products with prices per car lot.

OTTAWA, ONT.

MANUFACTURERS' PRICES.

Table listing lumber products in Ottawa with prices per car lot.

Table listing various lumber products like Pine good strips, Pine good shorts, and Pine, No. 1 dressing.

Table listing various lumber products like Pine, hox boards, Pine mill culls, and Pine O. culls.

SARNIA, ONT.

Table listing lumber products in Sarnia like Uppers, Selects, and Fine, Com. and Better.

Table listing lumber products in Sarnia like No. 1 Barn, No. 2 Barn, and No. 3 Barn.

ALBANY, N.Y.

Table listing lumber products in Albany like Uppers, Selects, and Fine common.

Table listing lumber products in Albany like 1x12 inch shippers, 4/4 inch, and 4/4 Box boards.

Table listing lumber products like Pine, Lath, and Shingles with prices per car lot.

BUFFALO AND TONAWANDA, N.Y.

WHITE PINE.

(Wholesale selling price.)

Table listing white pine products in Buffalo and Tonawanda with prices per car lot.

The following quotations on hardwoods represent the jobber's buying price at Buffalo and Tonawanda:

Table listing hardwood products like White Ash, Black and Brown Ash, Birch, Elm, and Maple.

BOSTON, MASS.

Table listing lumber products in Boston like White Pine Uppers, Selects, and Fine Common.

NEW BRUNSWICK CEDAR SHINGLES.

Table listing New Brunswick Cedar Shingles with prices per car lot.

BRITISH COLUMBIA SHINGLES.

Table listing British Columbia Shingles with prices per car lot.

WESTERN CANADA

Western Offices of The Canada Lumberman,
720-721 Union Bank Building, WINNIPEG, MAN.; 536 Hastings Street, VANCOUVER, B. C.

THE CANADIAN PACIFIC LUMBER COMPANY.

Twelve miles east of the city of Vancouver, on the south shore of Burrard Inlet, is Port Moody, the erstwhile western terminus of the Canadian Pacific Railway. Not much is left in the way of building of what at one time promised to be an important city. The extension of the C.P.R. westward practically killed the prospects of the town and the most important establishment now existing there is the large saw mill plant of the Canadian Pacific Lumber Company. The location is an ideal one. With the main line of the railway running right through their property, and the harbor nearby, where ocean going vessels can sail right up to within a stone throw of the mill, the shipping facilities are hard to beat. And the company have not been slow to make use of, and improve on, the natural advantages of their location.

The first mill was built some ten years ago by the Burrard Inlet Red Cedar Lumber Company, Limited. This mill had a capacity of about 65,000 feet per day of ten hours, and was operated under several different managements until six years ago, when it was taken over by the present company. From that time it was operated continuously until July of 1904, when fire destroyed the saw mill, machine shop, one large kiln, several



CITY OF NEW WESTMINSTER, B. C., WHERE DOMINION EXHIBITION WILL BE HELD, SEPTEMBER 27 TO OCTOBER 7, 1905.

The whole mill was designed and the work of construction superintended by members of the firm. Its present capacity is in the neighborhood of 100,000 feet per ten hours, but adequate provision has been made and ample power provided to increase this to 150,000 feet with but little additional outlay. This will be done as soon as trade conditions justify the expenditure.

The main mill building is 60 feet by 300 feet long and contains a double circular breaking down saw on one side, a 53 inch gang saw in the middle, while back of that is the 60 inch gang edger, opposite and to one side is the automatic slasher and automatic trimmer. On the side opposite the breaking down saw, room has been left for the installation of another breaking down saw and re-saw.

sizer and a sorting table. By a system of transfers and live rolls the lumber is carried from the main part into this wing, where several men are kept busy sorting out the material as it arrives.

The power plant for the saw mill is located in another wing 45 x 60 feet, also attached to the main building. Here are four large boilers, each 60 inches by 16 feet long, and a pair of driving engines, 20 x 24 inch cylinders. These engines run the breaking down saws, the live rolls, transfers, trimmers and conveyors. The gang saw is driven by a separate engine 14 x 20 and the edger and lath mill by another engine 14 x 18. A pair of engines 9 x 12 are used to run the sizer, the re-saw and the shaving fan. This use of separate power for the different machines is an important feature, as it permits



GENERAL VIEW OF SAW MILL OF CANADIAN PACIFIC LUMBER COMPANY, PORT MOODY, B. C.

planers and about half the stock of lumber on hand.

Nothing daunted, however, the company started in and rebuilt the mill, this time on a much larger scale. Construction on the new mill began on the first of September of last year and by the beginning of March following the new plant was in full operation under the same management as before the fire.

Everything has been arranged to work as automatically as possible, live rollers and transfers being used wherever possible, and the machines being so placed that each operation leads conveniently to the next. Of the twenty men employed on the mill floor not one has any real laborious work to do.

There is a 60 x 75 foot wing attached to the main mill building, what contains a lumber

the independent operation of parts of the mill.

A special feature of the new mill is the induced draft on the boilers. This is the only one in operation on any of the saw mills on the coast and is proving a great success. The system was specially designed by the members of the firm. It practically consumes the smoke and all danger of fire from sparks is eliminated.

The planing mill plant proper is on the

opposite side of the railway track, and having separate power may be run entirely independent of the saw mill. All material from the saw mill is delivered to the planing mill or dry kilns by an overhead tramway crossing the railway track. There are four dry kilns each 18 feet wide by 100 feet long. The planing mill is 52x60 feet. It consists of six large planers and other necessary machinery. The power for this is furnished by a 66 inch by 16



GANG SAW, CANADIAN PACIFIC LUMBER COMPANY.

foot boiler supplying steam for 14x18 inch cylinder engine.

Canadian machinery has been used almost entirely throughout the whole plant. The Waterous Engine Works Company, of Brantford, the Wm. Hamilton Manufacturing Company, of Peterboro', the Vancouver Engineering Works, and Ross & Howard, of Vancouver, all contributing to the successful and complete equipment of this up-to-date plant. The saws in use were all made by the A. J. Burton Saw Company, of Vancouver, and among the eighty saws furnished "there is not one," said Mr. Roe, the general manager, "that is not giving entire satisfaction."

The company aim to keep all their manufactured stock under cover, and to this end have erected four large sheds each covering over 30,000 square feet, in which to accommodate the manufactured stock on hand. Their trade is almost entirely, at present, with Manitoba and the Territories. The complete establishment at Port Moody covers an area of land about 2100 feet long by 1100 feet wide. The plant was located there with a view to both rail and cargo trade.

The company draw their supply of lumber principally from limits situated about 120 miles up the coast. They own sufficient timber limits to keep the mill running to its full capacity for twenty years to come.

The personnel of the Canadian Pacific Lumber Company is as follows: President, T. W. Paterson; vice-president and superintendent, Robt. Abernethy; secretary-treasurer, T. F. Paterson, and managing director, P. D. Roe.

Forest fires have recently done considerable damage in British Columbia and New Brunswick.

The Bailey Supply Company, Limited, has been organized at Winnipeg, to deal in oils, threshers, supplies, etc. The capital stock is \$30,000.

THE LUMBER BUSINESS OF BRITISH COLUMBIA: ITS FUTURE, AND THE QUANTITY AND QUALITY OF TIMBER.

By WILLIAM SHANNON.

Although it is over forty years since the lumber business was started in British Columbia, comparatively little is known of the resources of the country in this respect, even by the men engaged in the business. This need not be wondered at when we consider the extent of the timber areas and the roughness of the country. British Columbia has over a thousand miles of coast line from the southern boundary to Alaska, that is, including the bays and inlets, and many of the valleys and mountains are covered with a valuable growth of timber. No part of the world is so favorably situated with regard to water courses, these, in many cases, extending over a hundred miles inland; they can be safely navigated by the largest vessels afloat, and could afford perfect shelter for all the shipping of the civilized world.

Our coast being mountainous, we are supplied with water powers which cannot be equalled anywhere. Many of the streams coming in at the head of the inlets are capable of producing power enough to run several large mills.

The different timbers found in British Columbia are: Douglas pine or fir, which is of two varieties, red and yellow; red and yellow cedar, white hemlock, or Alaska pine; larch, cypress, white pine and spruce along the coast; and tamarack, Norway pine, black pine, white birch, cottonwood and poplar in the interior.

The Douglas pine or fir is found on the southern part of the coast, up about as far as Queen Charlotte Sound, or a distance from Vancouver of about 240 miles. There is very little of it found farther north. This timber is manufactured largely into lumber and shipped to the different markets of the world. It has always been largely sought after. It is known as red and yellow fir, but on close inspection it can easily be seen that it is of the same class of timber, but the soil and other conditions cause it to differ somewhat. The fir grown in favorable spots in the valleys and on the side hills, where it is shaded from the winds and the soil, is productive of a heavier growth, is softer and differs a little in color.

The red fir grows in the more exposed places on the side hills and other prominent points; it is harder, and there is more pitch in it, and, therefore, it is not so good for making boards, but is fully as good for bridge timber.

The red cedar generally grows among the fir, or in certain localities adjoining it, and on the northern coast, where there is no fir, the cedar seems to take its place. This timber, of late years, has been sought after for the eastern markets, but very little of it has been shipped abroad. It is the best shingle timber that we have in the province.

The hemlock that grows in the southern

part of British Columbia is generally known as the red or hard hemlock. It is not considered to be much good for lumber, and has not been made much use of yet. In the northern part of the province and on the higher levels of the mountains, we have what is known as the white hemlock, but the proper name of this timber is Alaska pine. The bark and the foliage somewhat resemble the red hemlock, but the wood is entirely different, being white and rather resembling the spruce in color. The trees are generally clear of limbs and knots, and there is no pitch to be found in this timber. It is used for finishing houses, also for making boxes, and in many cases, it has been made up into mouldings and doors. It is soft and very easily handled, having a strong tough fibre, and when painted is a very pretty wood.

The cypress or yellow cedar is to be found on the high altitudes, but is more plentiful on the northern coast, near Alaska. This yellow cedar resembles the red cedar very much in the bark and foliage, but the wood is entirely dissimilar, being of a yellowish color and more closer in the grain. It is a very heavy timber, and has a peculiar odor or smell. It is of great value for boat building and cabinet work, and makes most beautiful mouldings, and, when dressed and oiled, will polish equal to mahogany. It is by far the most valuable timber we have in British Columbia, but the quantity is very limited.

The larch is also generally found on the northern coast and on elevated mountain sides. It resembles the spruce in appearance, but the



AUTOMATIC TRIMMER AND TRANSFER ROLLS, CANADIAN PACIFIC LUMBER COMPANY.

wood is white in color. It is a stronger timber than the spruce and better for house finishing. The trees have generally very clean trunks, grow tall and straight, and are large and very round. Very little of this wood has been made use of yet, but the tests that have been made of it show it to be superior to either fir or cedar for house finishing. It is also a good wood to make into mouldings or doors. It is found in large quantities at different places along the coast, and it is the opinion of many experts in the timber business that it will be considered one of the most valuable timbers we have in a very short

time. Wherever it has been used it has given the best of satisfaction.

The spruce is to be found in the north in large quantities. Our spruce is what is generally known as the white spruce.

We have also what is known as the balsam, or white fir. For some purposes this is a very good timber.

The tamarack which grows in the interior of British Columbia is a very different tree to the tamarack to be found in the eastern countries; it attains a larger size and is clear of knots or limbs, and the trunk is very straight and round and makes the very best of lumber. It has also been used for shingles.

The Norway pine is something similar to what is found in the east.

The black pine is a very pretty tree; it never grows to any great size, but is noted for a very clean trunk and carrying its thickness. Although the bark is black, the wood is as white as snow and very soft. It makes a beautiful finish for housework. No white pine is a better quality of timber than this.

The size of the timber along the coast, especially the southern part, is very large, the common size of the fir being from three to six feet in diameter, and the red cedar is still larger. The larch is more of an average size than any other timber, being from two to five feet on the stump. The white hemlock is from eighteen inches to three and a half or four feet on the stump; the cypress in the north is about a similar size. The timber in the interior is generally of smaller growth.

In regard to the quality of the timber, it is a well known fact to those who are well acquainted with it that the timber in the north is decidedly of a better quality than that found in the south. It is a softer timber, with a stronger fibre, and is better adapted for nice finishing or fine work than the southern timber.

The white birch is to be found near the Peace river in large quantities; it is similar to the same class of timber in the east.

The timber of this province will cut about the following quantities: The southern part of the coast will average about 30,000 feet board measure to the acre; the northern part of the coast will average from 20,000 to 25,000 feet, and the interior will run much the same, although there are large districts of the country where the timber will not average more than 15,000 or 18,000 feet to the acre.

It is only within the last few years that lumbering has been carried on extensively anywhere. Mills are operated in the Kootenays and on the southern coast, but there are no mills on the northern coast, and but little timber has been taken from there yet.

Along the southern coast a large percentage of the timber is held by mill men and others. There are large quantities of timber on the west coast of Vancouver Island which still belong to the Crown; there is not much fir timber to be found there.

The timber along the northern coast is situated in benches and in places is elevated from two to three thousand feet above sea level. In many places it will be difficult to

take out, but this can be done by adopting the same system as is used in the mountains of Nevada. Here they bring portable mills into the mountains and saw up the lumber, and then run it through flumes; they put water in the flumes, which prevents the lumber from going too fast in the steep grades and floats it in the level places. In many places they have flumes from fifteen to twenty miles long. The same means will have to be used to lumber our mountain districts along the coast.

The amount of timber yet available in British Columbia, without counting the extreme northern part of the province, will amount to over 7,000,000 acres, not including the timber of the Great Laird River or the Cassiar country, where there are very extensive groves.

The market for the timber of the Kootenays is in the Northwest Territories, a market that is steadily increasing and in the very near future will be the greatest lumber market to be found on the continent of America. The market for the timber on the coast has been foreign in the past, and there has been a large quantity shipped to the North-west. The principal market has been found in South America and quite a quantity of lumber has been shipped to England and other parts of Europe and some to China, and the prospects of the markets that will be open to us in the future are indeed very bright. When we consider that the great timber areas of the Middle States have become depleted and that the large cities on the Atlantic coast will soon have to find their supply of lumber from another quarter, and the fact that the Panama Canal will be completed in the very near future, which will admit of steam vessels taking large cargoes of lumber from the different points along our northern coast and running to the docks of the large eastern cities and there unloading, we will readily admit that the prospects have never been so bright in the lumber business.

Many of the shrewdest Michigan lumbermen have invested already in our timber, with a view to manufacturing the lumber in the future and bringing it through the Panama Canal to the eastern markets that their people have been supplying for generations.

Another great market that is opening up for our British Columbia coast timber is China and Japan. It is well known that what little timber is in these countries is of a hard nature and not suitable for building lumber, and none of it is at all suited for the manufacture of pulp or paper. Mexico is filling up with people, and they will soon become great consumers of our lumber.

From present appearances, the duty on lumber going into the United States will be removed, and no doubt we will have a reciprocity of the tariff in this direction. This will give us one of the greatest markets to be found anywhere in the world, right at our door.

THE PULP BUSINESS.

Along the northern coast a large quantity of our timber is especially adapted for making pulp or paper, being of a soft nature, and as it is generally cut in short or cord-wood lengths

for this purpose, it would be much easier to take it out of the rough and inaccessible places. There is also considerable of the timber that would be too small for making lumber that is just suitable for pulp. In no other part of the world are such water powers available for this purpose, right on navigable water.

Our climate would also aid this industry, as it is mild and moist and work could be carried on during the whole year. It has been proved by experts that no part of the world possesses such large quantities of pulp timber as the Dominion of Canada, and we can say that no part of the Dominion of Canada possesses such fine pulp timber as British Columbia, or has the natural advantages for the manufacture of pulp or paper. The timber available for this purpose is unlimited, and the market for pulp is good.

It is well-known that Japan and China have no timber suitable for this purpose, and the amount that Japan is buying from all countries has more than doubled during the last four years, and no doubt in the future they will manufacture their pulp here and ship it to Japan and make paper there with their cheap labour, when they will be able to compete with any part of the world. Also, there is a large amount of paper and pulp shipped to Australasia, a country that has no pulp wood.

When we consider all these facts we must come to the conclusion that timber in no other country is so favorably situated as ours for the future market, and by judicious legislation the country will derive a great revenue from its timber.

In my next I will try to deal with our legislation and lumber laws, and the revenue that may be obtained from our timber.

THE MUNDY LUMBER COMPANY.

The new plant of the Mundy Lumber Company at Three Valley Lake, 15 miles from Revelstoke, B. C., commenced cutting early in July. The new mill has a daily capacity of seventy thousand feet. The mill building proper is 95 feet long by 44 feet wide. There is a "lean-to" wing adjoining, 48 feet long, with an average width of 35 feet. A separate building, of brick and stone, 28x50 feet, contains the engines and boilers. The planing mill building is located at one end of the saw mill and measures 30x50 feet. The saw mill is equipped with a saw carriage, 72 inches, open, operated by an eleven inch gunshot feed. This carriage is designed specially to handle the extra large logs which are abundant on the company's limits. A nine foot double-cutting band saw has been put in, also a steam log loader and kicker. The equipment includes a 54 inch edger, a five-saw overhead slab slasher, a three-saw trimmer, a lath mill, bolter and trimmer. A full set of live rolls and transfers is in use and a long sorting table with live rolls. The mill is thoroughly equipped with saw-dust conveyor and all other apparatus wherewith to keep the place as clean as possible.

The planing mill contains one heavy timber planer, two other very heavy planers, a large sticker and re-saw, besides the various other machines necessary to complete the equipment.

The brick engine and boiler house contains three boilers, 72 inches by 18 feet, developing 450 h. p., one engine 18 inches diameter with 36 inch stroke for running the saw mill and another 16x18 for the planing mill.

The whole plant was installed by the Waterous Engine Works Company, under the direction of their western representative, Mr. Hugh B. Gilmour.

THE Wood-Worker and Retailer

POWER REQUIRED FOR WOOD-WORKING MACHINES.

One of the first questions which the intending user of electric driving has to decide is the total quantity of power that will be necessary. Some very useful tables showing the power required by different wood-working machines have recently been published by the Clyde Valley Electrical Power Company, Glasgow, of which Mr. D. A. Starr, a well-known Canadian, is manager. We take the liberty of reproducing these tables below. The calculations are based on the machines being loaded.

WOOD BORING AND DRILLING MACHINES.

Horizontal boring and mortising machine, drilling 4 in. dia., mortising 8½ in. deep by 11½ in. long, 3.68 h.p. Boring and mortising machine, .49 h.p. Hatch boring machine, boring ⅝ in. hole in hatch 22 in. broad in two minutes, 3 h.p. Drill, 1¼ in. spindle, 6 in. stroke, drilling 1 in. hole, 1.09 h.p.

WOOD MOULDING MACHINES.

Edge moulder and shaper, vertical spindle, 2 h.p. Moulder, horizontal spindle, capacity 7½ in. by 2½ in., 2.45 h.p. Wood moulding machine, driven by 10 b.h.p. shunt 600 r.p.m. motor through belt, cutting teak about 5-in. square on three sides, and ploughing fourth side, moulding passing through 13 ft. per minute, 10.5 h.p.

MORTISING AND TENONING MACHINES.

Tenon and mortising machine, 2.11 h.p. Tenon and mortising machine, 2.73 h.p. Tenon and mortising machine, 2.25 h.p. Tenoning machine, 1-3 h.p. Dovetailing machine, to dovetail up to 15 in. to 36 in. wide by 1¼ in. thick, ¼-1 h.p.

WOOD PLANERS.

Planing machines, 36 in. wide, driven by 10 b.h.p. shunt 600 r.p.m. motor through belt, 3-16 in. cut off 27 in. wide pine at 14 ft. per minute, 8 h.p.; 5-16 in. cut off 12½ in. wide teak at 14 ft. per minute, 6 h.p.; ¼ in. cut off 22½ in. wide teak at 14 ft. per minute, 7 h.p. Planing machine 24 in. wide, driven by 5 b.h.p. shunt 600 r.p.m. motor through belt, planer speed, 2,200 r.p.m., planing 16¼ in. pine, ⅝ in. cut, at 14.5 ft. per minute, 3.25 h.p.; planing 16¼ in. pine, 1-32 in. cut at 14.5 ft. per minute, 2.5 h.p.; planing 14 in. pine, ⅝ in. cut, at 14.5 ft. per minute, 3 h.p. Planer, 12 in. cutter, taking 3 cuts to ⅝ in. or 3 in. pine, 2.32 h.p. Wood planer, 13½ in. rotary knives (2 horizontal, 2 vertical), 4.24 h.p. Wood planer, 24 in. rotary knives, 3.03 h.p. Wood planer, 17½ in. rotary knives, 4.63 h.p.

Wood planer, 28 in. rotary knives, 5 h.p. Wood planer, 28 in., Daniel's pattern, 3.20 h.p. Wood planer and matcher, capacity 14½ in. by 4¾ in., 6.91 h.p. Wood planing machine, cutting ⅝ in. off plank 10 in. broad by 17 ft. long in 1.5 minutes, 8.8 h.p. Wood planing machine, heavy, cutting ⅝ in. off plank 7 in. by 13 ft. 6 in. long in 30 seconds, 16 h.p. Thickness machine, 2 ft. 6 in. bed, surfacing yellow pine, 11 in. wide, at 13 ft. per minute, 5.5 h.p. Combined planing and moulder machine for flooring and match boarding, for planks up to 9 in. wide by 3 in. thick, 5-6 h.p.; for planks up to 16 in. wide by 6 in. thick, 7-8 h.p.

VARIOUS SAWS.

Circular saw, 10 in. dia., cutting 3 in. pine, 3.07 h.p. Circular saw, 23 in. dia., 3.23 h.p. Circular saw, 35 in. dia., 5.64 h.p. Circular saw, 32 in. dia., cutting yellow pine 11 in. deep at 7 ft. per minute, maximum, 12.4 h.p., average, 9 h.p. (motor and shafting alone). Circular saw, 33 in. dia., cross-cut lignum vitæ, 9¼ in. deep by 18 in. long, 12.6 h.p. (motor and shafting alone). Circular saw, 36 in. diameter, cutting yellow pine 11 in. deep 20 ft. per minute, 21.5 h.p. (motor and shafting alone). Band saw, 28 in. dia. wheel, width ¾ in., 2.33 h.p. Band saw, 34 in. dia. wheel, .96 h.p. Circular saw, 35 in., driven by 15 b.h.p. shunt 600 r.p.m. motor, belt from motor to saw, 3 to 1 ratio, cutting 10 in. teak about 8 ft. per minute, 14 h.p. Note—Belt slipping prevented a higher speed of cutting; with a better drive a 20 h.p. motor would be required. Portable circular saw, 24 in., D.D., 4 b.h.p. shunt 1500 r.p.m. motor, sawing 6 in. beech 4 ft. per minute, 4 h.p.; sawing 2 in. white pine 10 ft. per minute, 2.75 h.p. Band saw, 36 in. driving wheels, saw ½ in. wide, driven by 2 b.h.p. shunt 1000 r.p.m. motor through Renold chain, sawing 5½ in. Kauri pine, 1.43 h.p.; sawing 9¾ in. Kauri pine, 2.8 h.p.; sawing 7½ in. yellow pine, 1.63 h.p. Circular saw, 24 in., driven by 10 b.h.p. shunt 600 r.p.m. motor through belt, speed of saw, 1,000 r.p.m., cutting 5 in. ash about 10 ft. per minute, 6 h.p. Sawmill circular saw (to take 60 in. dia. saw), driven by 30 b.h.p. shunt 600 r.p.m. motor through belt, speed of saw 750 r.p.m., sawing damp pitch pine 12 ft. per minute, thickness from 10 in. to 17 in. (average, 14 in.). Power taken—Maximum, 36 h.p.; minimum, 21 h.p.; mean, 26 h.p. Grating saw, driven by 10 b.h.p. shunt 600 r.p.m. motor through belt—Work: Cutting 4 grooves 1⅝ in. wide by ¾ in. deep in teak, speed of cutting 2 ft. per minute, grooving, 10 h.p.;

the drive is a bad one with jockey pulleys for the belts. Small circular saw, cutting 6 in. pitch pine hand fed, 6.4 h.p. Band saw machine, to saw 16 in. to 22 in. deep, ½-1 h.p. Combined band saw machine and saw bench, to saw 9 in. deep, 4-5 h.p. Combined roller feed timber and deal frames, to saw logs 16 in. dia. by 25 ft. long, 3-4 h.p. Combined roller feed timber and deal frames, to saw logs 42 in. dia. by 45 ft. long, 12-14 h.p. Fret saw machine, to cut up to 8 in. deep, 1-1½ h.p. Rack feed timber frames, logs 16 in. in dia. by 25 ft. long, 4-5 h.p.; logs 36 in. dia. by 40 ft. long, 10-12 h.p. Rip-saw, cutting speed 9,000 ft. per minute, ripping hardwood 6 in. thick at 10 ft. per minute, 15 h.p. Roller feed timber frames, for logs 23 in. dia. by 25 ft. long, 5-6 h.p. Roller feed timber frames, for logs 30 in. dia. by 35 ft. long, 8-9 h.p. Log sawing machines, for trees up to 4 ft. dia., 4-5 h.p. Log sawing machines, for trees up to 6 ft. dia., 6-7 h.p. Rack circular saw bench, saws up to 42 in. dia., to saw 16 in. deep, 5-6 h.p. Rack circular saw bench, saws up to 78 in. dia., to saw 33 in. deep, 14-16 h.p.

MISCELLANEOUS MACHINES.

General joiner, four cutters, to saw 9 in. deep, to plane 9 in. wide by 3 in. thick, 5-6 h.p. Pattern maker's lathe, 2-3 h.p. Rounding machines, to round up to 1½ in. dia., ½-1 h.p.; to round up to 3 in. dia., 1-1½ h.p.

DETAILS OF POWER REQUIRED TO DRIVE A 24-IN. SAW FRAME.

Number of Saws.	Size and Character of Each Log.		Time Cutting of each Log	H. P. for each Log.
	ft. in.	in.		
12	18	16 deep. Birch	63	19
12	17	6 x 16 " "	50	22.21
12	27	6 x 16 " "	51	17.6
12	21	3 x 16 " "	49	21.8
11	15	0 x 14 " "	35	20.4
13	10	3 x 18 " "	22	17.4
13	9	3 x 17 " "	19	18.3
21	20	0 x 17½ Pitch Pine	42	26.2
14	31	3 x 17 Am. Ash	63	19.3
14	24	3 x 15 " "	41	20.7
15	17	0 x 16 " "	32	20.6
15	17	3 x 16 " "	29	21.1
28	16	0 x 22 Yellow Pine	—	27.4
28	16	6 x 23 " "	49	29.1
28	16	0 x 23 " "	48	27.4
28	13	8 x 22 " "	58	28.6

Power required to start machine = 23 h.p.
Running light = 9.75 h.p.

VIBRATION IN MACHINERY.

Under this heading a correspondent of the American Machinist tells some of his experience, among other cases of vibration being that of a dovetailing machine. He says: "This machine was among a group of other wood-working machines, including some planers. The spindle in this case was verti-

FOR THE CAMP

We have a very suitable lot of goods for camp supplies. We make this kind of trade a specialty. You who are not getting suited just as well as you would like, try us for your next order, and give us a chance to demonstrate our ability to give you satisfaction in this very important department of your business.

H. P. ECKARDT & CO.

Wholesale Grocers

TORONTO

cal, there being a journal at both top and bottom, and, in addition, an end journal to support the weight of the shaft and to take up any end play, as end play in a machine of this description would cause the dovetails to be cut to uneven depths, thus spoiling the appearance of the work. There was no heavy mass attached to this shaft, as in the case of the disk grinder, there being simply a plain shaft with two collars at the top journal and the dovetailing cutters having a tapered shank and fitting into the top of the spindle, which was driven by a light pulley about 4 inches in diameter.

This machine would run for a long time without any vibration, then without any apparent reason it would commence to vibrate so badly that it was impossible to do any work on it, which proceeding on its part greatly puzzled the man in charge. His method of getting over the trouble was to stop the machine and wait some time, then start up again, when it was often found that the vibration had disappeared. As the trouble was getting worse, it was decided to call in the engineer and get things made right. On examining the machine, it was found that the journals had worn very loose and that the shaft was also pretty badly worn; the journals were adjusted and the machine speeded up and ran all right. There was a slight vibration, but it was practically nothing, and would not affect the working of the machine.

Suspecting, however, that the slackness of the journals was not altogether the cause of the vibration, the engineer asked to have some of the machines around started up, still keeping the dovetailing machine running. All the machines were fixed on a wooden floor supported by joists underneath and raised some distance from the ground. No sooner were some of the machines set in motion than the dovetailing machine seemed to get into tune with the vibration set up in the floor and to vibrate very badly. This satisfied the engineer that it was the shaft that was at fault, and, seeing that it was somewhat worn, it was decided to make a new one in preference to using any means to put the machine out of tune with the rest or deaden the vibration. When the new shaft was put in place and connected up there was no further trouble.

James Ford, an American timber cruiser, was drowned recently in Jervis Inlet, B.C.

FISHER'S POWER RIVETING MACHINE.

The illustration shows a power riveting machine which has been in use in the United States for about three years, for use in riveting hoops for pails, lard, jelly and candy packages, etc. The inventor has now made arrangements for its manufacture, under the Canadian patent, with the John McDougall Caledonian Iron Works Company, Limited, of Montreal.

Provision is made in the machine for bringing up the rivets, successively, in position to be engaged with the hoop, and for heading the rivet with a hammer, or

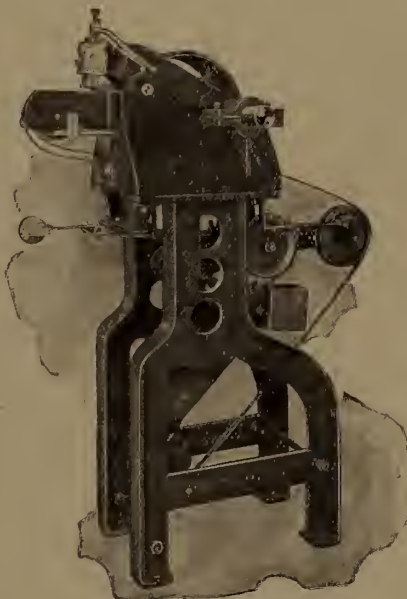

FISHER'S POWER RIVETING MACHINE.

more properly with a press, which runs continuously by power. Suitable provision is also made for holding the lap closely during the riveting process. This construction allows the operator the use of both hands exclusively for handling hoops, thereby enabling a boy or girl to rivet rather more than double the number of hoops, in a given time, which could be riveted by the old process.

The machine has a record in the United States of one hundred hoops riveted in three minutes.

SCROLL, RIP AND RESAWING MACHINE.

This engraving represents the No. 5 patent heavy band-scroll, rip and re-sawing machine manufactured by the Defiance Machine Works, of Defiance, Ohio. It is a combination of three machines in one, and it will be found a most desirable and useful tool for woodworkers in general. It will do all kinds of scroll sawing from the most delicate work using the finest saw blade, up to sawing heavy hard wood such as used in wagon, agricultural implement, railway cars, and ship construction work. It is capable of carrying a saw blade up to 2" wide, and as a hand feed ripping saw it covers every requirement and it will be found more economical than a circular saw, as the saw kerf is smaller, and it will do more work and do it easier without the liability of injuring the operator. As a re-sawing machine, it will split lumber 12" wide and any-

thing narrower, either straight or beveling, and it will saw smooth and true. It can be changed in a moment's time from one class of work to the other.

The frame is a massive casting in one piece, with cored center and a broad floor base to stand firm. Every line in its design is new and original.

The table, of iron, is in two parts, the one at the left is stationary, and it is 20" by 29"; the main table is 30" by 34", and it is arranged to tilt for bevel sawing to 45° angle, by a circular rack and pinion operated by a convenient hand wheel, which is provided with a friction binder to lock the table and hold it in any desired position. The circular bearing underneath the table is laid off in degrees, so that it can be accurately set to any angle required. The distance from the inside of the frame to the saw is 36", and it measures 51" from the inside of the frame to the outside edge of the table, giving ample room for large wide sawing.

The patent rip saw gauge is attached to the table by

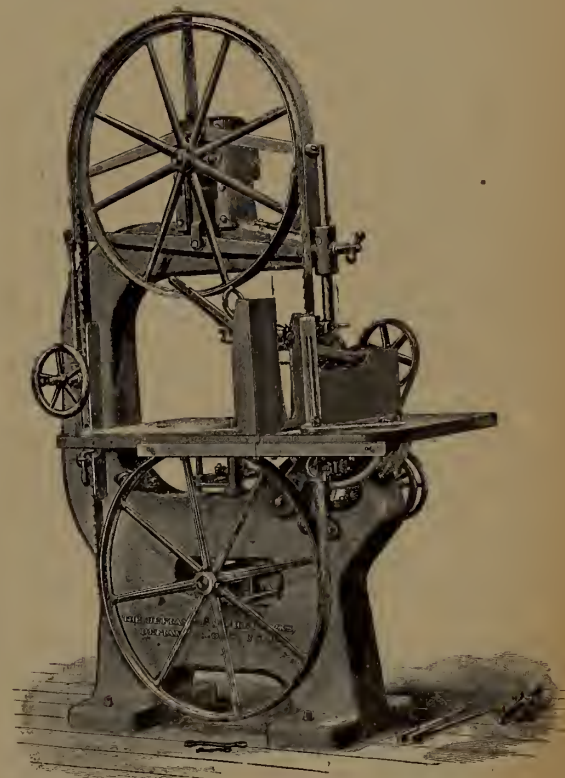

NO. 5 PATENT HEAVY BAND-SCROLL, RIP AND RE-SAWING MACHINE.

a friction binder, and it can be instantly set to any position. It can be used on either the right or left hand side of the saw. A scale is laid off on the table by which to set the gauge the desired distance from the saw, without the use of a rule.

The re-sawing attachment is accurately constructed with cut gears and is driven by a belt from the lower wheel shaft. It can be quickly adjusted to saw lumber of different thickness, and width and when the table is tilted, it will saw beveling.

J. W. Turnbull has started a lumber yard at Pense, N.W.T.

THE NEWS

ONTARIO.

—Thomson & Emery have built a sash and door factory at Fort Frances, Ont.

—William Lawson, of Shallow Lake, Ont., is building a saw mill at Cockburn Island.

—Robert Stewart, Limited, Guelph, Ont., are building a three-storey addition to their planing mill.

—The new saw mill of W. Mason at Hintonburg, Ont., is expected to be in operation early this month.

—James Bennoch, lumber merchant, Stratford, Ont., has sold out to Brown & Company, Limited, of St. Marys.

—Jessie Seygley, of Pelee Island, Ont., while running a portable saw mill on his farm, fell on the saw and was killed.

—The North Bruce Lumber Company, of Lion's Head, Ont., met with the misfortune of having their tug "Gertie C." burned.

—The name of Graham, Horne & Company, Limited, Mine Centre, Ont., has been changed to the Mine Centre Lumber Company, Limited.

—The Frank Perry Lumber Company, of Tuckersall, in the Lake Superior district, recently took about 100 men to their timber limits about fifty miles north of Michipicoten, Ont., where operations will be carried on this winter.

—Mr. Davidson has purchased forty acres of land for his proposed woodenware factory at Haileybury, Ont. It is understood that he is negotiating for a timber limit. The factory is not likely to be built until next year.

—The Algonquin Company, Limited, has been incorporated, with head office in Toronto and a capital of \$300,000. It is proposed to operate timber limits and saw mills and engage in the destructive distillation of wood and the manufacture of bi-products. The directors of the company are: Thomas Minton, F. Sinclair, William Bullock, John Creighton and G. T. Bullock, all of Toronto.

—It is understood the management of the Lake Superior Consolidated Company are considering the re-opening of the sulphite pulp mill as soon as arrangements can be made for a supply of raw material. A report from Superintendent Hodgson, who has charge of this department, shows the amount of wood cut for the various works this year as follows:—120,000 cords of wood for the charcoal plant, 130,000 cords of wood for the pulp mill, 10,000,000 feet of pine for the saw mills, and 200,000 feet of birch for the veneer mills.

—The Temiskaming Lumber & Manufacturing Company, Haileybury, Ont., has been incorporated with a capital of \$500,000, to acquire timber lands, operate saw mills and manufacture woodenware. The incorporators are: Frank Thomas Lawlor and Harvey D.

Graham, of Haileybury; Wesley D. Davidson, lumber merchant, and Harvey E. Howe, lumberman, of Rawdon, Que., and Elmer D. McCallum, timber scaler, of Vankleek Hill, Ont.

THE EASTERN PROVINCES.

—Robert Loughery contemplates building a saw mill at Canaan, Que.

—O. Dufresne, jr., & Frere, lumber dealers, Montreal, have dissolved, and O. Dufresne, jr., has registered a new business.

—The new planing mill of Laverdure & Son at Janelville, Que., has been completed.

—J. D. Bush and Benjamin F. Bush have registered under the name of Bush Bros. to operate a sash and door factory at Sherbrooke, Que.

—The rotary saw mill and lumbering equipment of William H. O'Brien will be sold by public auction at Bathurst, N. B., on September 5th.

—James Waddell intends installing steam power in the saw mill at Reed's Point, N. B., having purchased the necessary engine from the Waring Company, of St. John.

—Rev. W. S. Bullock has erected a saw mill and sash and door factory at Roxton Pond, Que., operated by water power. A new dam was built, giving a 70 foot head.

—The Miramichi Lumber Company has been organized in Portland, Me., for the purpose of doing a general lumber business in New Brunswick, Canada, and elsewhere, with \$400,000 capital. R. C. Bradford, of Portland, is president.

—The Fred S. Morse Lumber Company, of Springfield, Ohio, advise us that they are handling a considerable quantity of spruce and cedar shingles from Quebec. They are also wholesalers of all kinds of southern woods, including cypress, hard pine, white-wood, etc.

—Two portable mills owned by J. P. Mosier and operated at Musquash, N. B., under the supervision of G. Brittain, of St. Martins, recently cut 750,000 feet of lumber in two weeks, or an average of over 31,000 feet a day for each mill. This is good work for a portable mill.

—At the annual meeting of the Trois Pistoles Pulp & Lumber Company, held at Trois Pistoles, Que., last month, the following officers and directors were elected for the ensuing year: President, E. W. Tobin, M. P.; vice-president, Fred S. Morse; secretary, J. A. Begin; treasurer, R. T. Wells. The company have two mills producing spruce lumber and cedar shingles.

—Robert McElroy has rebuilt the saw mill at Grafton, N.B., which he purchased last spring. The main mill is 110 x 30 feet and contains a new rope-feed

rotary and improved shingle machine with patent shingle bolter, a patent edger, a rotary bed-planer, a new endless haul up gear and a new lath machine. The engine room is 36 x 21 ft. and contains a 100 horse power engine and a small portable boiler used for running the steam pump in case of fire. The boiler house is 41 x 19 feet and contains two steel boilers. The furnaces are arranged to burn all the sawdust and refuse.

MANITOBA AND THE TERRITORIES.

—W. H. Mills has opened a lumber yard at Okotoks, N. W. T.

—The Gibson Lumber Company have opened a lumber yard at Riverside, N.W.T.

—Skead & Company, Limited, lumber dealers, Calgary, N.W.T., have been incorporated.

—The Medicine Hat Lumber & Manufacturing Company has commenced at Medicine Hat, N.W.T.

—The Davidson & Fraser Lumber Company, Limited, have purchased the business of the Great West Lumber Company, Moose Jaw, N. W. T., and intend increasing the quantity of lumber carried in stock.

—The Independent Lumber Company has recently been formed at Moose Jaw, N.W.T., James C. Shields being the manager in charge. Col. Stevenson, of Detroit, is the president. It is said to be the intention to locate yards at a number of important points in the province.

—The Northwest Lumber Company and Blain & McKelvey, who operate saw mills at Ponoka, N.W.T., applied to the authorities to control the waters of Pigeon Creek sufficiently to permit of log driving operations. This permission having been refused, these firms are now considering the removal of their mills to Pigeon Lake.

BRITISH COLUMBIA.

—The name of the Hunting-Lea Lumber Company, Vancouver, B. C., has been changed to the W. F. Hunting Lumber Company.

—The saw mill at Morrissey Junction, B. C., recently purchased by A. J. McGuire & Company, has resumed operations. The product will be both lumber and shingles.

—The logging firm of McDougall & Cameron, of Vancouver, B. C., recently sustained considerable loss as the result of forest fires. Their donkey engine was damaged.

—The new saw mill of the Moore & Whittington Lumber Company at Victoria, B. C., was completed last month and is now in operation. It is equipped with the latest machinery and has a capacity of 25,000 feet

TENTS

That are the acme of perfection, in all details of work. BRITISH ROYAL NAVY method of cut, workmanship and finish. MATERIAL used made in SCOTLAND by the Navy Contractors. Samples and prices are mailed on request.

TOBIN TENT & AWNING CO. OF OTTAWA Long Distance phone No. 432

CRAIG MINE CRYSTAL CORUNDUM WHEELS

Our Pure Crystal Corundum Saw Gummars have no equal for their Rapid, Cool, Cutting Properties.



Read the following from Bulletin 180 of the United States Geological Survey, which says:

"Often a distinction is made between emery and corundum, many persons not recognizing emery as a variety of corundum.

Emery is a mechanical admixture of corundum and magnetite or hematite. It is, of course, the presence of corundum in the emery that gives to it its abrasive qualities and makes it of commercial value, and the abrasive efficiency of emeries varies according to the percentage of corundum they contain."

Emery is imported, mined by Greeks and Turks and contains only about 25% corundum. Our Crystal Corundum is guaranteed to be 98% pure alumina, a Canadian product, mined and manufactured by Canadians for Canadians.

HART CORUNDUM WHEEL COMPANY, Limited, Hamilton, Ont, Can.

per day. Directly across the bay the new mill for John Taylor is being rapidly carried to completion. The site is an ideal one, having ample room for yard purposes.

—The Cooke & Tait Lumber Company, Vancouver, have just installed a battery for cutting flooring. Their dry kilns are being moved to a more suitable location.

—Fire was discovered in the lumber yard of the Royal City Planing Mills at New Westminster, B.C., on August 10th, but was extinguished before much damage was done.

—The induced draft system that was installed in the boiler room of the Royal City Planing Mills at New Westminster has been running for two months now and is giving every satisfaction.

—The Elk Lumber & Manufacturing Company, Fernie, B. C., are shipping lumber to the Northwest Territories and as far east as Winnipeg. The mill has a capacity of 150,000 per day.

—It is announced that the Cananian Pacific Lumber Company, which already operate a large saw mill at Port Moody, B. C., will shortly build another mill there, for which purpose the Rock Point property has been purchased.

—The Brunette Saw Mills and the Royal City Planing Mills, of New Westminster, B.C., are each supplying about half the lumber used in the construction of the new Industrial Building and the new Manufacturers Building for the Dominion Fair in that city.

—The mill of the North Star Lumber Company, Cranbrook, B. C., has recently been closed down for improvements. A new edger and trimmer and a set of live rolls have been installed and other improvements made which will greatly facilitate the work of the mill.

—The W. F. Hunting Lumber Company, of Vancouver, will commence work on the extension of their mill early this month. The new part will be built on to the old site, extending out over False Creek. When complete this plant will have a daily capacity of about 500,000 shingles.

—The Ladysmith Lumber Company have decided to remove their saw mill now situated at Fiddicks, B. C., to a site about four miles from Ladysmith. When rebuilt the mill will be thoroughly modernized and largely increased in size. Arrangements have been made for a spur line of railway to the mill. This location will bring the mill nearer the company's timber limits.

—A quantity of saw mill machinery recently left Vancouver, B. C., on the steamer "Tartar" for Canton, China, consigned to the Wan Yip Timber Company. It is understood that the Canadian machinery excels anything of the kind to be obtained in China, and that the Chinese are putting into practice the experience which they have obtained in the saw mills of British Columbia.

—A report from British Columbia states that parties who expect the Grand Trunk Pacific to run at least a branch line through House Pass in the Rockies to the north of Beavermouth, are planning a raid on timber situated on Canoe Creek and on the North Fork of the Columbia, in the neighborhood of the Big Bend dis-

trict. It is reported that at least 150 square miles of timber lands will be taken up if the report of an expert, who is now cruising the land, turns out as satisfactorily as expected.

—Ralph Simpson has an up-to-date shingle mill at Arrowhead, B.C. The main building is 40 x 50 feet and the boiler house 20 x 35 feet. The present capacity is 40,000 shingles per day, but it is proposed to install two more machines during the coming winter. The mill has been in operation since April 1st, and has been kept very busy; in fact, Mr. Simpson has been unable to fill the orders as fast as they have come in. He has now on hand several orders for carload lots for Northwest customers. He usually gets a good price, which is due to the fact that he manufactures a No. 1 shingle.

—No doubt a great many lumbermen intend visiting the Dominion Exhibition to be held at New Westminster, B. C., from September 27th to October 11th, and the Union Lumber Company, of Vancouver, extend a cordial invitation to all such to visit them in their new offices, 536 Hastings street, opposite the Molsons Bank. And, realizing the trouble and inconvenience many are put to, especially at Exhibition time, through having their mail come to the General Delivery, they further suggest that any who wish, may have their mail addressed care of the Union Lumber Co., Box 407, Vancouver, and it will be a pleasure to see that the letters are carefully looked after.

—E. G. Pake, formerly a lumberman at Duluth, Minn., has been in British Columbia recently making arrangements for building a large saw mill on the west coast of Vancouver Island. He is general manager of the Sutton Lumber & Trading Company, which has large holdings of timber in the vicinity of Clayoquot, about 75 miles northwest of Victoria, B. C. The plan is to erect a mill to cut the cedar timber into rough lumber for shipment around the Horn in sailing vessels to New York for the trade of the New England States. It is expected that the mill will be ready for operations early next year. Mr. Pake was for a long period superintendent at Duluth for Alger, Smith & Company.

—John Hanbury, of Brandon, Man., has purchased the box factory and saw mill of the British Columbia Box & Lumber Company at Vancouver, B. C. The plant consists of a band mill re-saw and other necessary equipment. It is his intention, for the present at least, to discontinue box-making and run the mill altogether on cedar lumber. As the business progresses, additional plant will be added and the mill enlarged. The purchase of this property gives Mr. Hanbury a chain of mills, located at Brandon, Manitoba, and Cranbrook, Moyie, Elko and Vancouver, B.C., He has also secured 11,000 acres of timber limits at Sechelt and about 4,000 acres in the Kootenay district.

—In connection with the harbor improvements at Vancouver, B.C., is a large area of "made land" that is being reclaimed between the C.P.R. station and the Pacific Coast Lumber Company. A very admirable arrangement has been entered into between the railway and the lumber company. The C.P.R. are putting in a bulwark of stone and piling about 200 yards from the shore, the Pacific Coast Lumber Company are filling in between with their refuse, and the railway company will put on a top coating of earth three feet thick. By this arrangement the lumber company easily dispose of their refuse and the C.P.R. get good filling-in material right at hand. The conditions attached are that the Pacific Coast Lumber Company may use the area, which is probably a quarter of a mile long, for a piling ground until such time as the C.P.R. needs it for its own purposes, which may be years hence.

—The Red Cedar Lumber Company, of Vancouver, have just completed a new brick stack 75 feet high, doing away with the old iron stacks. A great objection to the iron stacks has been the action of the salt water atmosphere on the metal, causing them to give out within one or two years, oftentimes falling and compelling a temporary cessation of operations. A feature of their new stack is a brick sawdust burner attached to it. The burner is built like a huge box some 15 feet high, the top being in the form of a hopper so balanced that the weight of the refuse falling on it from the carrier causes it to open, depositing the refuse inside. The stack and saw-dust burner are located about fifteen feet away from the boilers, but the smoke from the latter will be conveyed by draft pipe into stack directly above the level of the top of the burner. This design of stack and burner is entirely new in Vancouver but promises to be thoroughly efficient and is certainly a very safe arrangement.

Two recent publications from Sheldon & Sheldon, Galt, Ont., describe their steel plate fans and steam specialties.

—A report from Bloomfield, Vt., states that the Connecticut Valley Lumber Company has entered a suit against the Grand Trunk Railway involving half a million dollars. The lumber company claims that 30,000 acres of timber land owned by the company were destroyed in 1903 by fire, said to have been caused by a locomotive of the defendant corporation. The claim of the Connecticut Lumber Company is for \$300,000. Several other cases will be brought up by different lumber firms, with losses aggregating \$200,000 by the same fire, as these firms have agreed that the Connecticut Valley suit shall be regarded as a test. More than 500 witnesses have been summoned.

RAILS and TRACK SUPPLIES

NEW and Re-Laying from 12 to 60 lbs. per yard with fastenings; for Lumbering, Mining and Contracting Work. Immediate shipment from Stock. Get our prices before purchasing.

SESSENWEIN BROS.,
101 Shannon Street, Montreal

The Man Who Knows He Has a Good Thing



Hanchett Circular Swage Shaper

s always glad to send it out on trial for he knows that it is the best way meritorious goods can get an even show with weaker imitations. We are always glad to send the **Hanchett Saw Swages and Pressure Side Shapers** out on approval. Will save your saws and make them need less care when fitted with these tools.

Let us send them to you for 30 days use.

Write us for prices, etc.

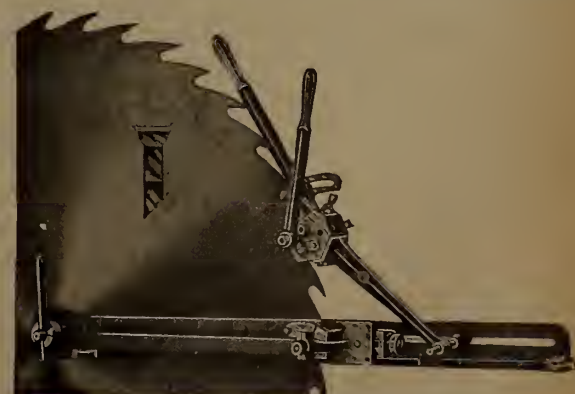

Hanchett Circular Saw Swage

HANCHETT SWAGE WORKS, BIG RAPIDS, MICH., U.S.A.

WOOD PULP ~ DEPARTMENT

COUNTERVAILING DUTY ON CANADIAN PULP.

Collectors of customs in the United States received instructions, about August 1st, to collect 25 cents per ton additional on all importations of ground wood brought in from Quebec, regardless of whether the wood from which the pulp was made was cut on Crown lands or not. This extra assessment is known as a countervailing duty, the same being to offset the rebate of 25 cents per cord allowed by the Province of Quebec on the cost of wood cut on Crown lands when that wood is ground into pulp anywhere in Canada. Since the decision of the United States Board of General Appraisers in the countervailing duty cases, the collectors at the various ports have been assessing the extra duty only on pulp made from wood cut on Crown lands or where the pulp was mixed, being part from Crown land and part from private land wood.

An appeal against the above duty was taken to the Northern District Court of New York, and Judge Ray, in his review, affirms the decision of the United States Board of General Appraisers. His decision is as follows:

This is an appeal from a decision of the Board of General Appraisers, rendered February 17, 1904, imposing a countervailing duty on wood pulp imported from the Dominion of Canada.

Albert H. Washburn for the United States. Henry J. Cookingham for appellant. Ray, District Judge.

This appeal relates to protest 58,943-B, 59,372-B, 59,489-B, 58,164-B, 58,162-B, 58,160-B, and 59,940-B, countervailing duty on wood pulp.

Subdivision 393 of the Tariff Act of 1897 reads as follows:

"Mechanically ground wood pulp, one-twelfth of one cent per pound, dry weight; chemical wood pulp, unbleached, one-sixth of one cent per pound, dry weight; bleached, one-fourth of one cent per pound, dry weight: Provided, that if any country or dependency shall impose an export duty on pulp wood exported to the United States, the amount of such export duty shall be added, as an additional duty, to the duties herein imposed upon wood pulp, when imported from such country or dependency."

The wood pulp in question came from Canada as an importation into the United States.

The board held that pulp manufactured in Ontario from wood cut from public lands in Quebec was subject to the countervailing duty; that pulp made from wood cut from public lands in Quebec and manufactured in Quebec was subject to the countervailing duty; that pulp manufactured from wood cut from private lands and manufactured either in Quebec or Ontario was not subject to the countervailing duty, and that as the pulp could not be segregated but the proportions could be established by a percentage, the entire importation was not subject to the duty, but only that percentage of pulp which was made from wood taken from public lands.

The importers contend:

First.—That the Government has no right to impose a countervailing duty upon pulp imported from any part of the Dominion of Canada.

Second.—That in any event the countervailing duty cannot be imposed upon pulp manufactured in Ontario from wood cut on public lands in the Province of Quebec.

Third.—That in no event is the countervailing duty leviable on pulp imported from Quebec except as to the extent that it is made from wood cut on public lands, and upon which there has been a reduction of the stumpage dues.

The Dominion of Canada is divided into provinces, among which are Ontario and Quebec.

By the British North America Act (Chap. 3 of 30-31 Victoria) the Dominion of Canada has exclusive power to impose export or import duties. But in sections 91 and 92 of that act we find in the distribution of powers among the Provinces that it is provided each Provincial Legislature has the following power of legislation: (1) Power of direct taxation within the province in order to the raising of revenue for provincial purposes. (2) Management and sale of public lands belonging to the province and of the wood and timber thereon. (3) Shop, saloon, tavern, auctioneer and other licenses, in order to the raising of the revenue for provincial, local or municipal purposes. I think each province has the power of taxation by way of license in those matters confided to it. If in the exercise of this power lawfully granted, whether by the mother country direct or by it through the Dominion, the province in point of fact and effect imposes an export duty on pulp wood exported to the United States, it is an imposition of that duty by the Dominion of Canada. There is no question that the Dominion of Canada is a dependency of the Kingdom of Great Britain.

I do not regard it necessary to recite the various laws, &c., bearing on the subject. In effect, by authority of law, an export duty is imposed. It is not done directly by the Kingdom of Great Britain or directly by the Dominion of Canada, but it is done under legislation authorized by the Dominion.

I cannot agree with the reasoning that arrives at a conclusion that this is not a duty imposed by a dependency of the country we call England, one of the great powers of the world. It is not called an export duty by that Dominion, but is imposed as a license fee. The merchandise cannot escape our law because we call it export duty and Quebec or Ontario calls it a license. The question is what is it in effect and in fact.

The decision of the Board of General Appraisers is affirmed.

DUTY ON ROSSED PULP WOOD.

The unexpected action of the United States Treasury Department in notifying the collectors of customs to assess all importations of rossed wood at 20 per cent. ad valorem has aroused the indignation of the large consumers in the United States. The officials of each one of the big paper companies that draws its supply principally from Canada are considerably exercised over the new turn of affairs. All of them have filed protests in the names of their companies against the collection of the duty. In addition to these protests there is now a movement on foot to make a joint protest to the authorities at Washington.

In the protest the main point that will be brought to the attention of the Secretary of the Treasury will be the fact that the delay in settling the controversy over the duty rests with the Government, as the case on appeal

has been before the United States Circuit Court for over a year. It will be recalled that the United States Board of General Appraisers on March 31, 1904, rendered a decision in favor of the importers and against the assessment of the 20 per cent. duty that had been imposed under instructions from Washington. From this decision continuing the free entry of rossed wood the Government appealed in the early part of the following May. Since then the case has slumbered in the clerk's office at Burlington, Vt. Because of the delay of the Government to prosecute its appeal the paper manufacturers concerned took it for granted that nothing further would be heard of the case.

Now, after two years since the 20 per cent. duty was assessed, namely, June, 1903, the importers are suddenly aroused from their slumber by the instructions sent out by the Treasury Department to the collectors to assess rossed wood at 20 per cent. pending final decision by the courts.

The Paper Trade Journal says that practically all the paper manufacturing companies in Northern Maine, New Hampshire, Vermont and New York are now in arms against the assessment of the duty. As the outlook for getting the order rescinded is not good, many of the manufacturers have already made arrangements to have their wood shipped in the rough with the bark on. But, although there seems little chance of continuing the free entry for rossed wood, the paper men concerned are not going to let the matter drop without first making a vigorous protest. The unfairness of their treatment at the hands of the Government is what they object to principally. The case, they say, should have been decided long ago if the Government really meant to try to collect 20 per cent. ad valorem on rossed wood on the ground that it was a manufactured article.

Canadian pulp wood shippers were notified by their American representatives to ship no more rossed pulp wood to the United States for the present. It is estimated that only about half of the year's shipments have been made so far, and the remainder is on the hands of the Canadian shippers. Canada exports about 500,000 cords of pulp wood per year, about half of which is machine peeled.

PULP NOTES.

Dr. Carl Kellner, Ph. D., the well known expert in sulphite wood pulp matters, whose name is familiar to all in the paper and pulp industry, died in Vienna recently.

The Royal Paper Mills at East Angus, Quebec, have been closed for an indefinite period. It is stated that an effort will be made to sell or lease the property. The pulp mill will be continued in operation, as will the saw mill.

The C. W. Rantoul Company, of 41 Park Row, New York, have taken the selling agency for the high grade ground wood output of the Brompton Pulp and Paper Company, of Brompton Falls, Que. The mill of this company, completed a little over a year ago, is said to be one of the most thoroughly up-to-date pulp mills in the country.

Herr A. Scheck, a commissioner of the German Government, who has been in Canada recently making an inspection of forests, says that we have enough pulp wood to supply the world forever. The pulp wood consumed in the German Empire, he says, has come in the past from Norway and Sweden, but the resources of those kingdoms are becoming exhausted, and as a result the German Government is looking for a new source of supply. For the past three years Herr Scheck has been studying the forests of the United States and submitting reports thereupon to the German Government.

C. H. VOGEL

A. M. Can. Soc. C.E.
OTTAWA, CAN. ENGINEER

Surveys, Plans, Specifications and Supervision

WATER POWER

Paper, Pulp and Sulphite Fibre Mills

PAT. OSCILLATING BOB SLED KNEE
Hauls 25 per cent. easier, and wears longer, and is lighter than all others.

THOMPSON MFG. CO., Ltd.,
Grand Bay, N. B.

G. T. KNIGHT & SON

Manufacturers of

Building Supplies

we make a specialty of
Doors and Sashes; Mouldings and all kinds of turned goods.

Address, MEAFORD, ONT.

Phone
Main 2158

Alexander
Engraving Co.

Half Tone,
Zinc-Block,
Wood Engraving,
Photo Engraving,
Photo Lithography

14 Adelaide St. West
Toronto, Can.



“DOBLE” Tangential Water Wheel

3,700 H.P., 240 R.P.M.,
1,531 Ft. Head, 12 Ft. 5
in. Dia., 17,000 Lbs.

Doble Wheels Were Awarded the Grand Prize at St. Louis Worlds Fair.

THE JOHN McDOUGALL
GALEDONIAN IRON WORKS COMPANY,
Ltd.

MONTREAL

—BUILDERS FOR CANADA—

Write for Bulletins No. 6 and 7.

ELECTRICITY

If you desire to keep posted on the wonderful progress that is taking place in the use of electricity for an almost endless variety of purposes, you should subscribe to the

Canadian Electrical News and Engineering Journal

A 44 PAGE MONTHLY,
PRICE \$1 PER YEAR

Write for free sample copy to

The G. H. Mortimer Publishing Co.

LIMITED

Toronto - Montreal - Winnipeg

Shingle Saw Grinder

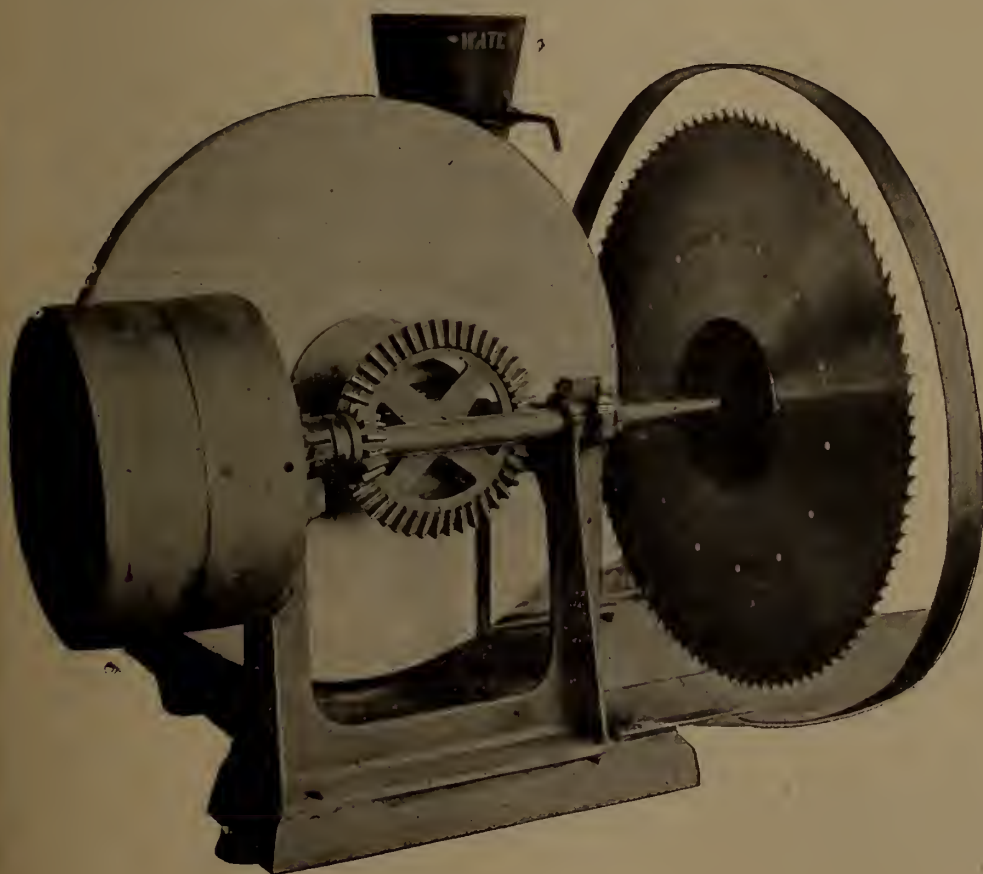

FOR keeping down the thickness of shingle saws and thereby saving timber, we are now putting on the market a grinding machine. Several of these machines have been running in different mills for some months. It will at once be seen that we have made a radical change from anything at present on the market for this purpose. The saws are ground much quicker with the grindstone than with the emery wheel. It is also found that the grindstone does not roll the saws out of shape as the emery wheels do. The cut shows the machine so clearly that very little, if any, explanation is necessary. The shaft on which the saw is fastened is driven direct with the belt; the grindstone being driven with a bevel gear and pinion. The grindstone is made to move back and forth by the cam. The grindstone shaft is not at right angles to the saw shaft, but at an angle equal to the taper on the saw. This angle can be made greater or less by turning the eccentric sleeve in which one end of the shaft runs. The position of the feeding cam can be adjusted in or out by slacking up the bolts holding it and pushing it in the direction wanted. The machine is simplicity itself, and as will be seen, is built very strong.

Letson & Burpee, Limited, Vancouver, B. C.

FORESTRY DEPARTMENT

MUNICIPAL FOREST RESERVES.

Mr. Thomas Southworth, Director of Forestry for Ontario, has this to say in his last report on the subject of municipal forest reserves:

"As a preliminary and experimental measure looking toward the creation of small municipal reserves in settled districts possessing considerable areas of non-agricultural or inferior land, I would suggest that the Assessment Act be amended so as to allow townships to hold, in perpetuity, lots purchased at tax sales. If it were considered advisable, the power to hold such lands for a longer period than seven years might be restricted to such areas as the municipal council might by by-law set apart as forest reserves, subject to such regulations regarding their management as might from time to time be enacted by the Provincial Administration. The small value attaching to

such waste and partially denuded areas as the abandoned clearings which are sold for taxes enables the community to reclaim at trifling expense a large portion of the territory which should never have been allowed to pass into the hands of private owners, and the communities more especially interested ought to be permitted to take advantage of the opportunity thus presented to restore to useful production by reforestation such lands as have proven unfit for agricultural development".

New Ontario, Mr. Southworth says, is rapidly being denuded of trees, and he expresses the opinion that the province should retain the ownership, or at any rate the control of a sufficient proportion of the areas thrown open for settlement to insure the preservation of an adequate proportion of wooded land to maintain the favorable conditions of climate and water supply for the development of the districts in question. The ideal system which would secure the maximum of productiveness both as regards agriculture and the industries dependent upon wood as a raw material, would be the maintenance of a number of small local

timber reserves interspersed throughout the cultivated districts under some form of efficient public control. While it might not, for various reasons, be possible to at once establish such a system on as comprehensive and scientific a basis as could be desired, a beginning should at least be made by the setting aside before the country is opened up for settlement such small tracts of land as are obviously better adapted for the growth of timber than for tillage."

Mr. Southworth continues: "It seems desirable that before any new township is thrown open for settlement the surveyors be instructed to report as to rough and non-agricultural land embraced within its boundaries with a view to withdrawing such areas from settlement and retaining them as timber reserves. The surveyors, in addition to considering the nature and quality of the soil, should also be instructed to have special regard to the location of such non-arable or poor lands, as regards streams and water-courses as an important factor in deciding whether such land should be reserved or thrown open for occupation."

LUMBERMEN

— SHOULD SEE OUR —

PATENT SEAMLESS HEEL LARRIGANS

No chance to rip where it generally does rip
in the ordinary make. Also our

PATENT LEGGING

The only legging where the bell front is held down close to the foot so that
it can't turn up

— BOTH MANUFACTURED BY —

THE R. M. BEAL LEATHER CO. LIMITED.

LINDSAY, ONT.

Write Us

Steel Frame
Dry Kiln Trucks
Plain or Roller
Bearing Wheels
Steel Frame Lumber Trucks
WRITE FOR BLUE PRINTS
MONTEITH, NIXON & CO.
Makers of Good Trucks
256 Macdonell Ave. - TORONTO

GIANT CAR MOVER

SEE THAT SLIDING WEDGE
IT BLOCKS THE WHEEL,



M'n'f'urers Price

\$3.00
EACH

B. & R. Patent

CASH WITH ORDER
OR BY EXPRESS C. O. D.

Thousands of Testimonials.

See "THE RAILWAY EQUIPPER"
Our Monthly Publication. Mailed Free
M. MITSHKUN CO. DETROIT, MICH.

For Fans, Separators, Dust Collectors Blowers and Shavings Systems Heating and Dry Kiln Systems

SEND FOR CATALOGUE TO

HINRICH & PACE - Revelstoke, B. C.

The Cook & Bros.
Lumber Co.
Of Ontario, Limited
MILLS at SPRAGGE, Algoma Dist., Ont.
on "Soo" Branch C.P.R.
OFFICES: (Manning Arcade, Toronto
Coristine Building, Montreal
And at Mills at Spragge.

MANUFACTURERS OF

White and Red Pine
Lumber and Lath

Water Shipments

PAROID ROOFING

FOR THE

PANAMA CANAL

The first proposals issued by the Isthmian Canal Commission called for Paroid Roofing, or equal, and the order was placed with us.

The U. S. Government again recognizes the standard qualities of Paroid, having used many carloads in this country, Cuba and the Philippines.

If you believe in quality, get our samples and booklet.

F. W. BIRD & SON, MAKERS,

HAMILTON, ONT.

Established in U. S. A. in 1817.

LUMBER INSURERS GENERAL AGENCY, INC.

MANAGERS OF THE EXCLUSIVELY LUMBER INSURING COMPANIES

LUMBER UNDERWRITERS

F. W. MATTOCKS, Attorney

UNDERWRITERS

CHAS. M. BETTS H. SHUMWAY LEE C. H. PRESCOTT, JR.
 C. H. CARLETON ROBERT C. LIPPINCOTT FRANK C. RICE
 FRED'K W. COLE JOHN JAY MCKELVEY HORACE F. TAYLOR
 LEWIS DILL ANGUS MCLEAN M. S. TREMAINE
 W. A. HOLT FRED'K W. MATTOCKS PENDENNIS WHITE
 W. C. LAIDLAW EUGENE F. PERRY

LUMBER INSURANCE CO. OF NEW YORK

PENDENNIS WHITE, Pres. HORACE F. TAYLOR, Vice-Pres. R. H. MCKELVEY, Sec.

DIRECTORS

S. M. CLEMENT JOHN D. LARKIN HENRY J. PIERCE
 LEWIS DILL JOHN JAY MCKELVEY C. H. PRESCOTT, JR.
 WM. H. GRATWICK HUGH MCLEAN FRANK C. RICE
 WILLIAM HAMLIN FRED'K W. MATTOCKS HORACE F. TAYLOR
 W. A. HOLT GEORGE A. MITCHELL PENDENNIS WHITE
 W. C. LAIDLAW EUGENE F. PERRY

COMBINED ASSETS OVER \$500,000

66 BROADWAY, NEW YORK

Sept. 1, 05

To Canadian Lumbermen—

Last month you entertained as your guests the members of the National Wholesale Lumber Dealers Association. You may be interested to know that it has been brought out at various meetings of this Association that one alone of our several lumber insurance companies has saved to the members yearly more than the entire expenses of conducting the Association.

Our companies were organized by members of the National Association to insure lumber exclusively - and at right rates. Our facilities are open to every clean, well-managed lumber yard.

*Respectfully
 Lumber Insurers Genl Agency*

CHAIR OF FORESTRY.

First steps toward the raising of \$150,000 to be used in the endowment of a chair of applied forestry at Yale University were taken at a meeting of the executive committee of the National Lumber Manufacturers' Association at Chicago last month. The committee has in charge the raising of the necessary funds for the endowment of a special committee of three practical lumbermen to co-operate with the Yale Forest School faculty with a view of directing the course of study along practical lines and also of the work of securing a committee of 100 lumbermen, who will have charge of the work in the various lumbering districts.

Try an advertisement in the CANADA LUMBERMAN.

SETTLERS LOW RATES WEST.

The Chicago and North Western Railway will sell low one way second class settlers tickets, daily from Sept. 15th to Oct. 31st, 1905, to points in Utah, Montana, Nevada, Idaho, Oregon, Washington, California and British Columbia. Rate from Toronto to Vancouver, Victoria, New Westminster, B. C., Seattle, Wash., or Portland, Ore., \$42.25; to San Francisco or Los Angeles, Cal., \$44.00. Correspondingly low rates from all points in Canada. Choice of routes. Best of service. For full particulars and folders write to B. H. Bennett, General Agent, 2 East King St., Toronto, Ont.

P. PAYETTE & CO.

Manufacturers of Saw Mill and Engine Machinery and all kinds of Marine Machinery.
1 ENETANGUISHENE, ONT

THE LUMBER ANTI-STAIN COMPANY

Head Office, WILMINGTON, DELAWARE

To the Lumber Trade of Canada:

We hereby give notice that two infringement suits have been filed in the Circuit Court of the United States for the Western District of Michigan, Northern Division, for the infringement of our patent No. 746,678, dated December 15, 1903, relating to the treatment of lumber for the prevention of sap staining, and we warn others that infringements of our rights will be vigorously prosecuted. Rights to use this valuable process may only be obtained by applying to

Robert H. Munson, President,

Lumber Anti-Stain Company,

Sault Ste. Marie, Mich.

Our Canadian patent is number 91936.



These Mules Cannot Break This Yarn

BECAUSE IT WAS MADE BY THE

Consumers Cordage Co., Limited



Poor Yarn is Dear at Any Price

We Manufacture

**Double and Single Lath Yarn,
Shingle Yarn, and Cordage**

Of Every Description

Our mills are equipped with the latest improved machinery for making extra long lengths of Transmission Rope.

CONSUMERS CORDAGE CO., LIMITED
Montreal and Halifax

New Sawmill Machinery FOR SALE



- One No. 1 Lane Mill R. H. Wood Frame. 16 ft. Carriage, Rope Feed, New.
- One No. 0 Lane Mill R. H. Wood Frame. 24 ft. Carriage Rack and Pinion Feed, New.
- One No. O Lane Mill R. H. Wood Frame. 25 ft. Carriage Rack and Pinion Feed, New.
- One 50 in. Circular Rip Saw, Shurley-Dietrich, New.
- One 2 Saw Trimmer, New.
- One Lockport Shingle and Heading Machine, New.
- One Double Edger, 3 Saw complete with End Tables, New.

MISCELLANEOUS

- 15000 ft. Sprocket Chain, all styles.
- 3000 ft. Manilla Transmission Rope.
- 5000 ft. Rubber Belting.
- A Large Stock of Pipe and Boiler Tubes.
- Wood and Iron Pulleys, Pillow Boxes, Hangers.

The above Machines are all new and are offered at prices that must compel attention.

The Manitoba Iron Works Co.

LIMITED

Logan Ave. W., WINNIPEG

THE LUMBER MUTUAL FIRE INSURANCE COMPANY

BOSTON, MASS.

STRENGTH

NET ASSETS, MARCH 31, 1904

\$684,105.91

ECONOMY

DIVIDENDS TO POLICY HOLDERS

33 $\frac{1}{3}$ %

MAIL EXPIRING POLICIES WITH YOUR ORDER.

WARNOCK TOOLS

Best in the World



If Strength, Durability, Correct Construction and Lightness are an object, we have the article you are looking for.

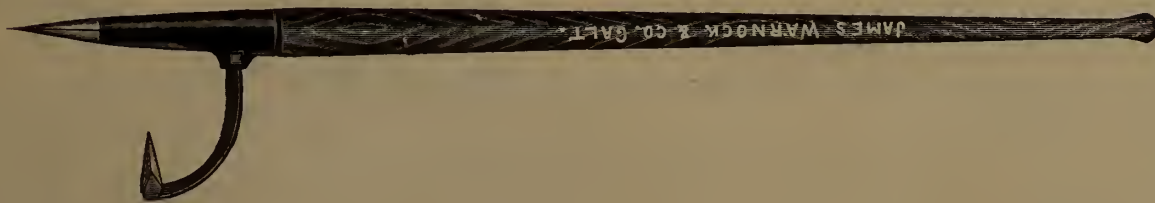
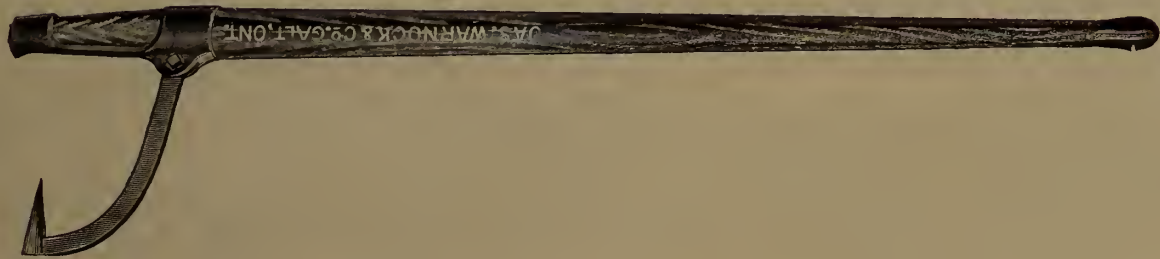

THE JAMES WARNOCK CO., LIMITED
GALT, ONT.

THE DYMENT FOUNDRY COMPANY

BARRIE, ONTARIO

Manufacturers of

Engines, Boilers Steam Feeds . . .

AND A COMPLETE LINE OF

Saw, Shingle and Lath Mill Machinery

Can ship mills in a week's notice. Write us for prices and Catalogue.

F. J. DRAKE'S

SAW AND SHINGLE MILL MACHINERY

STATIONARY SAW MILLS
PORTABLE SAW MILLS
SHINGLE AND HEADING MACHINES
SHINGLE AND HEADING JOINTERS
TIE MILLS. SLASH TABLES
LATH AND PICKET MACHINES
LATH BOLTERS. LUMBER TRIMMERS
LOG JACKS AND CHAINS
SAW CUMMERS
DRAG SAW MACHINES
SHAFTING, PULLEYS, ETC.

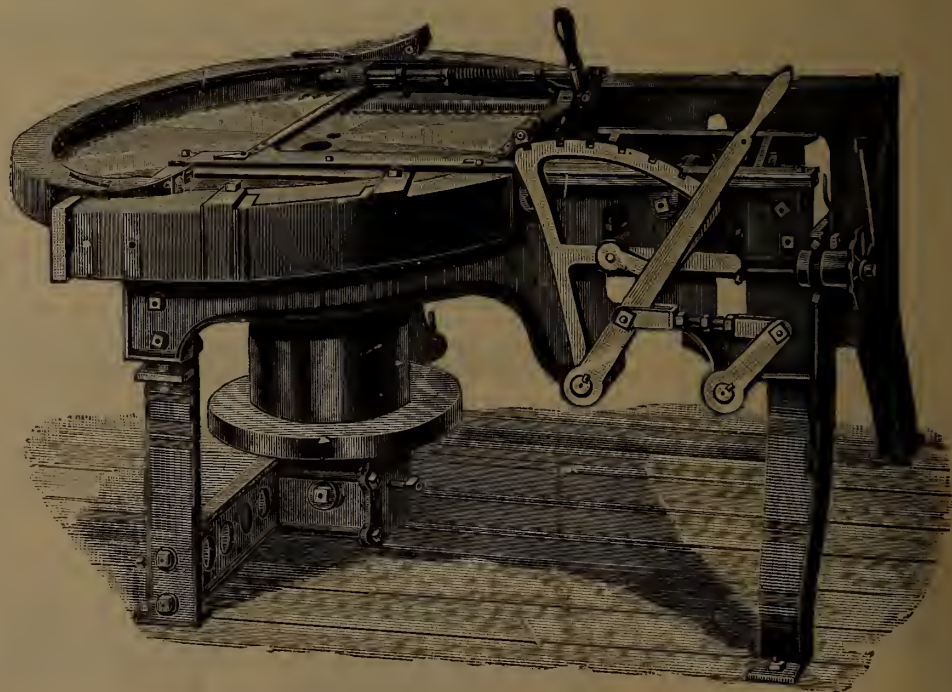

*Complete Outfits of Mill Machinery
at Bottom Prices*

Capacity 25,000 to 50,000 per day.

F. J. Drake,

BELLEVILLE,
ONTARIO

P. H. WRIGHT
43 Bank Street, OTTAWA
Lumbermen's Agent
All kinds of Mill and Bush
help secured on short notice
Telephone 2586

OILS

Manufacturers High-grade Cylinder, Machine and Sawmill Oils.

Calypsol Grease

for Sawmill Purposes a Specialty.
Our products are made from finest Pennsylvania stocks.

We solicit your correspondence.

St. John St.,
MONTREAL. Commercial
Oil Co.,
Offices and Works: Manchester, Eng. Hamilton, Ont.
Hamburg, Germany.
Newark, N. J.
Chicago, Ill.

THE E. L. PURVIS CO.,
18 COLBORNE ST., TORONTO, ONT.



PIPE AND BOILER COVERINGS

Asbestos Mineral Wool
and all kinds of Fireproofing

Material Agents for

FAMOUS MICA COVERINGS

H. J. FRIEL
EMPLOYMENT AND LUMBERMEN'S AGENT
Bushmen supplied on short notice, also
mill hands. Hotel help of all kinds procured.
Office: 73 BANK STREET
Phone 721 OTTAWA



Sole Canadian Agents - Prices Reduced
WATEROUS, BRANTFORD, CANADA

MAPLE LEAF
STITCHED COTTON DUCK
BELTING
DOMINION BELTING CO. LTD.
HAMILTON CANADA

WANTED

**Supplies
Beech, Maple or
Birch Cutwood**

To be air-dried and cut from Prime Clear Stock.
11 1/2" long x 7/8" and 15 1/2" long x 1" x 1".

Also

Maple or Sycamore Squares

From 1 1/2" to 4" Square, rising by eights, and in
multiples of 7" long up to 28".

Quote lowest prices per cubic foot delivered
c. i. f. Liverpool, England,
to Box No. 50
CANADA LUMBERMAN

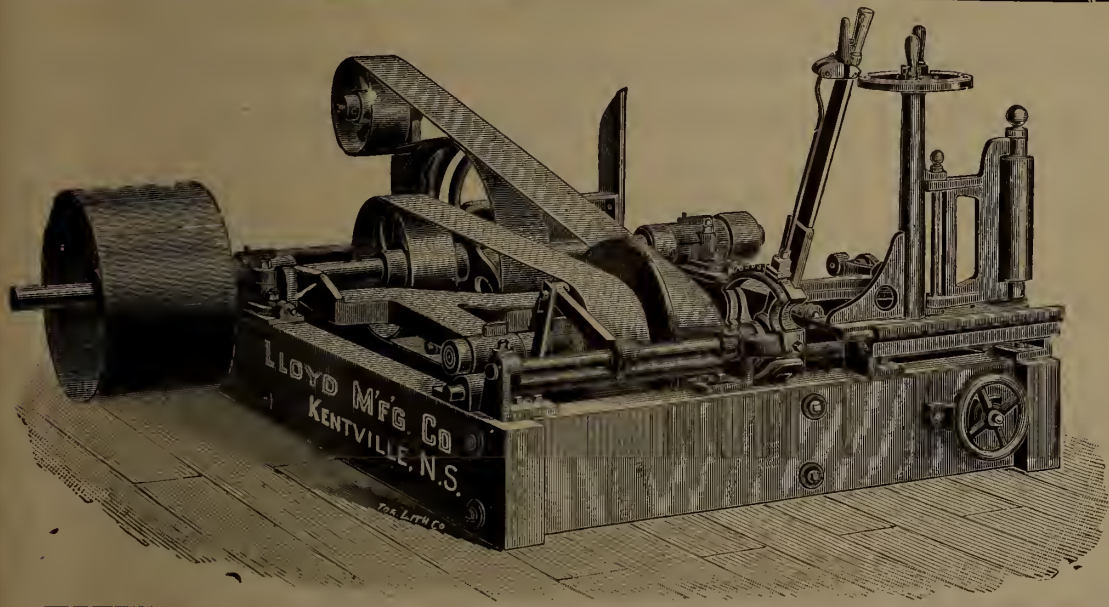

**Lloyd Manufacturing
Go'y** JOHN I. LLOYD, Proprietor.

SAW MILL OUTFITS

Pulp Machinery, Belting, Etc.

OUR SPECIALTIES:

- Band Saw Mill Machinery,
- Improved Rotary Saw Mills,
- with Green Mountain Dogs,
- Also Screw Post Dogs,
- Turbine Water Wheels,
- Power Feed Gang Edgers
- Buzz and Surface Planers,
- Heading Rounders,
- Stave Machines, Stave Jointers
- Stave Planers.

KENTVILLE, N. S.

Special to Lumbermen, Miners and Railway Contractors



We are Manufacturers of:—Mince Meat, Baking Powder, Coffee, Spices,
Flavoring Extracts, Mustards, Tomato Catsup, Worcestershire Sauce,
Jams, etc., and all kinds of Grocers' Sundries for Camp Use. Also Sauer
Kraut, Pickles and Sausage Meat.

- Mince Meat put up in 75 Pound Tubs. 1/2 Barrels about 300 Pounds.
- Barrels about 600 Pounds.
- Sauer Kraut and Pickles in Barrels. Sausage Meat in 50 Pound Tins.
- Sauce and Catsup in 5 Gallon Pails.

ALL GOODS GUARANTEED

Special Attention Given to Mail Orders



The Capstan Manufacturing Co., TORONTO, ONT., CAN.



Ever
seen
one
of
these
powerful

MCCIFFERT LOG LOADERS

at work, loading or skidding logs, or maybe, switching its own empties? If you haven't you can't fully appreciate the immense amount of heavy work it can do—and at such a saving. It is really wonderful.

You'll be interested in "Modern Methods in the Woods" appearing in the October issue of this paper. Watch for it—read every word. It will pay you.

Clyde Iron Works
Duluth, Minnesota, U. S. A.

FOR IMMEDIATE SHIPMENT

☐ A Water Wheel Plant consisting of a pair of our 30 in. Crocker Turbines horizontally set in central discharge Steel Case. All complete with Draft Tube, Driving Pulley and Woodward Governor.

☐ We have this plant in stock ready for instant shipment.

☐ We invite enquiries and will promptly furnish complete information.

☐ We can make the price attractive.

THE JENGKES MACHINE CO., LIMITED
SHERBROOKE, QUE.

ATKINS ALWAYS AHEAD!



QUALITY IS THE THING!

THE MILLMAN'S MILLENIUM

Is not yet here, but the introduction of Atkins Silver Steel Saws has made the day appreciably nearer.

Atkins Saws are as perfect as modern, up-to-date methods, human ingenuity and skill can make them.

They are the most economical Saws to operate because they are tempered just right and will hold a keen cutting edge longer and do 25% more work without filing, will saw true and always make first-class, even lumber, thus being conducive to the operator's peace of mind, happiness and prosperity.

A trial will demonstrate the truth of this statement. Let's hear from you. Our Sawyer's Hand Book free for the asking.

E. C. ATKINS & CO., Inc.,

Leading Manufacturers of Circular, Band, Cross-Cut, Hand and Wood Saws, Etc.

Factories and Home Office,
Indianapolis, Ind. U.S.A.

Canadian Branch,
56 King St East, Toronto, Ont.

The Gravenhurst

"BOSS" SHINGLE MACHINE

The Best Machine on the Market

The Simplest in Construction of any Machine Built

We build Shingle Machines both Horizontal and Vertical
We also build All Kinds of Saw Mill and Shingle Mill Machinery.

Send Us Your Orders, Large or Small—We Can Fill Them

Write for Catalogue

B. R. MOWRY & SONS
GRAVENHURST, ONT.



**SHERMAN'S
FLOORING MACHINES**
PATENTED

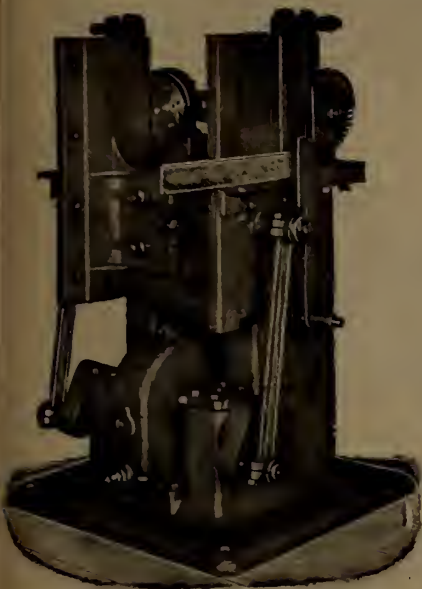

Above cut shows our End Matcher, the best machine in the market for end matching flooring strips. They do rapid and accurate work, and are durable—therefore used by leading flooring manufacturers. Make your flooring profitable by end matching it.

We Make the
**SHERMAN SIDE
BORING MACHINES**
and the
**SHERMAN FACE
BORING MACHINES**

To bore flooring while it is being run on the flooring machine. Write for circular and list of users

W. S. SHERMAN CO.
1150 Holton St., Milwaukee, Wis.

**Reliable
Veterinary
Remedies**

No logging outfit is complete without a supply of reliable veterinary remedies. Getting the wrong kind means the loss of the use of your horses when time is valuable.

Johnson's Veterinary Remedies are guaranteed never to fail when used as directed. You get your money back if they ever do.

They are
Johnson's Horse Liniment No. 1.
A penetrating Alcoholic Liniment. Put up in one gallon jugs, with full directions, per imperial gal. \$4.50

Johnson's Horse Liniment No. 2.
A combination of the best oils used as liniments, imp gallon . \$3.00

Johnson's Horse Colic Remedy.
A sure and speedy cure for colic Imperial gallon \$5.00

Johnson's Veterinary Healing Ointment.
Positively the best all-round healing ointment made. In use by the largest owners of horse flesh in Canada. Put up in 2 lb tins, each . . . \$2.00 or in 1/4 lb tins, per dozen . . \$3.00

Johnson's Condition Powders. (Concentrated). Put up in bulk, per lb . . . 3c.

These goods being put up in bulk are more economical than others, as cost of bottling, etc., is saved.

CAMP REMEDIES.

In addition to our Veterinary Remedies we make a line of medicines for lumbermen, including a strong, penetrating liniment, healing ointment, cholera cure, liver pills, cough syrup, in fact anything in the form of Camp Drug Supplies. We know that there are no better remedies made than those we offer. There may be others nearly as good, but they lack our guarantee. Satisfaction or money back. A trade discount of 10% allowed off all orders amounting to \$100.

Send postal for printed matter.

A. H. JOHNSON
Wholesale Druggist
Collingwood, Ont.

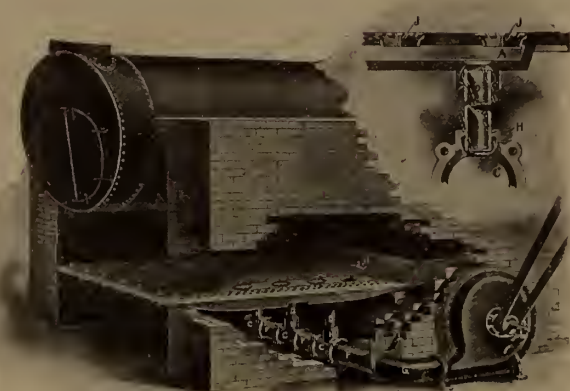

The Gordon Hollow Blast Grate Co.
Greenville, Michigan

SOLE MANUFACTURER OF

THE GORDON HOLLOW BLAST GRATE
AND
THE FAMOUS "TOWER" LINE
OF
EDGERS AND TRIMMERS

The Gordon Hollow Blast Grate makes two boilers do the work of three, gives as good results with wet, green or frozen sawdust or other refuse as a draft grate gives with dry wood, and saves labor in firing. We pay the freight. Sold on approval, and returnable at our expense, if unsatisfactory.

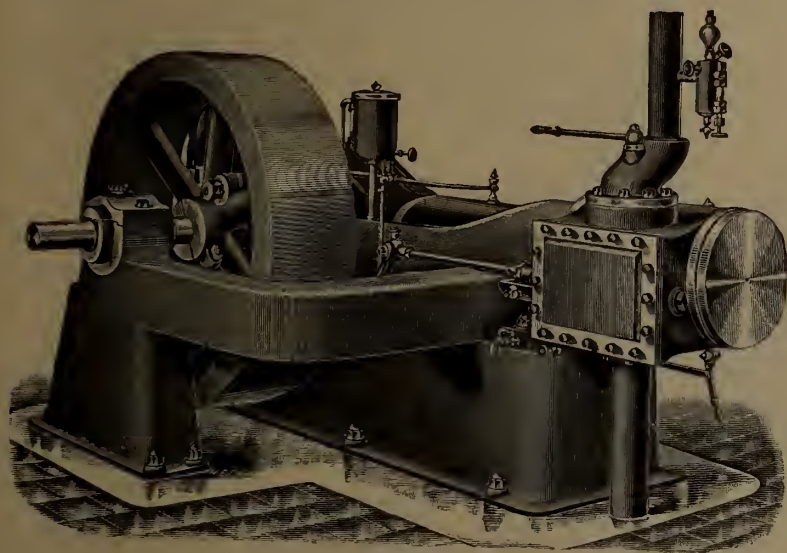

Our Engines are fitted with Automatic Governors and run at Regular Speed, whether Loaded or Light.

They use about 25 Per Cent Less Steam than the best engines with a throttling governor.

They are built on the Interchangeable System so that duplicate parts exact in fit can be supplied at any time.

In Sizes up to 125 Horse Power the outboard bearing is attached to the frame, as shown in the cut, keeping it perfectly in line.

ROBB ENGINEERING CO., LIMITED
Amherst, N.S.

Gonnell & Dengler Machine Co.

ROCHESTER, N. Y.

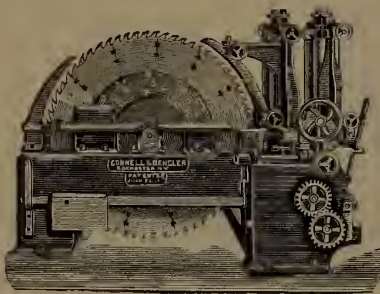

44 inch Circular Re-Saw.

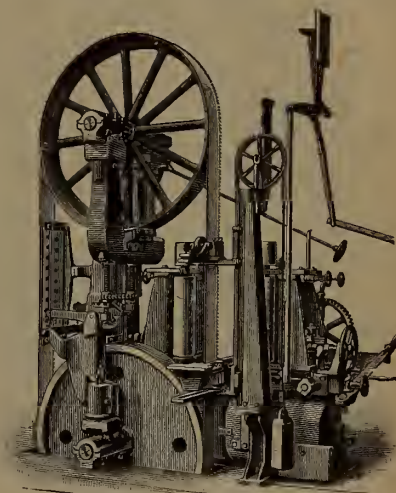

60 inch Band Re-Saw

Manufacturers
of . . .

**Box Makers' and
Planing Mill Machinery**



Heavy 26 inch Divided Roll Planer and Matcher with 8 Feed Roll.

Dundas Lumberman



A New Axe tempered by a new process which enables us to submit to any lumberman three or more samples of Axes, all different degrees of hardness, and on a selection being made we will guarantee to furnish any number all exactly the same temper as sample chosen.

THE DUNDAS AXE WORKS
Dundas, Ont.

FOR THE GAMP TABLE

- Mess Pork
- Short Cut Pork
- Plate Beef
- Dressed Fresh Beef
- Long Clear Bacon, Butter, Cheese, &c.
- Smoked Hams
- Roll Bacon
- Pure Lard
- Pork Sausage

Write us for Special Prices on Car Load Lots.

THE PARK BLACKWELL CO., L'T'D

PORK AND BEEF PACKERS
TORONTO



Let Us Lend You a Hand in Making Shingles

We know something about the game of shingle making. Been at it—perfecting shingle making machinery for over 29 years, and we're not stretching the truth a particle when we say our line of Hand Feed, Single, Double and Ten-Blockers is without a peer on the market.

No matter what kind of a Shingle Machine you buy,

IF IT'S A "PERKINS"

you can rely on getting more and better shingles from the same stock and with less trouble and expense than with any similar machines. Cut shows our celebrated COLUMBIA SINGLE-BLOCKER—the champion one-blocker of the world. Write for catalog explaining our full line.

PERKINS & CO. - Grand Rapids, Mich.

RODGERS IRON MFG. CO. MUSKEGON, MICH.

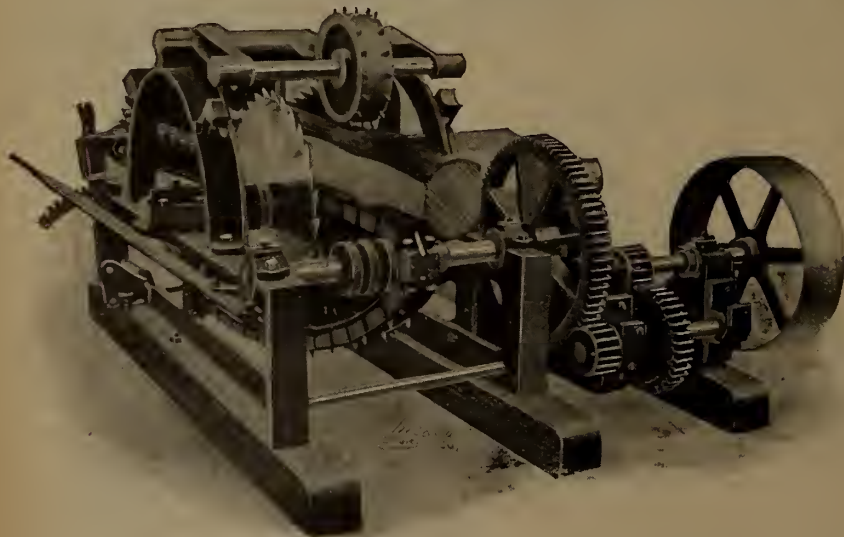

ADJUSTABLE LOG SIDER OR TIE MACHINE.

A Money Maker Write to Us
We will Tell You All About It



Rodgers Iron Mfg Co.,
Muskegon Mich.

Gentlemen—In regard to the adjustable log siding machine which we purchased of you, it is far beyond our expectations. We are now running 3" saws and have no trouble in sabbing our logs from 10" to 20" in diameter. We consider the machine one of the best of the kind on the market; in fact we know of no machine which will equal the one which we have. It is giving entire satisfaction, and we would be glad to show it to any parties who may be interested if they will call at our mill.
Yours very truly,

Berkley, Norfolk, Va., Sept. 8th, 1904.



Rodgers Iron Mfg. Co.,
Muskegon, Mich.

Gentlemen -
Replying to yours of recent date and referring to your Tie machine, we are cutting from 1,000 to 1,200 mine ties, 5 feet long, per day, with a 25 horse power engine.
Respectfully,

Fleming, Centre Co., Pa., March 11, 1905.

Cross-Grained and Knotty Lumber IS WELL FINISHED WITH

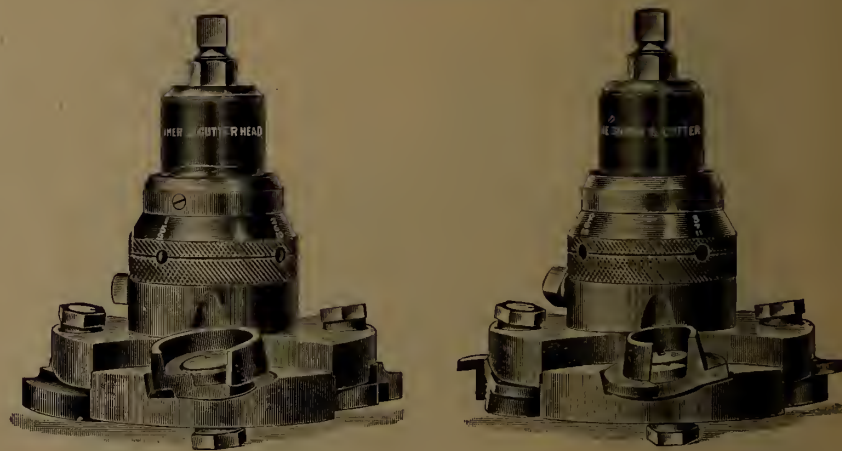

The Shimer Gutter Head

It reduces the number of culls as no other Head can.

The Cutters work alternately with side clearance; ply their way through the worst lumber that you may find for high grade finish.

The bit seats and their bit and bolt combinations supply the make-ready for every emergency.

For tight and loose fitting of tongue and groove joint, a single turn of the Expansion ring will suffice, with automatic stop and lock.

Nothing { COMPLICATED, TO GET OUT OF ORDER

The Shimer Cutter Head is made to fit any make of matcher or moulder. You take the measurements—we do the rest, and guarantee to fit your spindles. Address

SAMUEL J. SHIMER AND SONS
Milton, Pennsylvania

Perfect Swing Shingle Mill

Fitted with our "Automatic Trip."

Best Swing Shingle Machine on the Market today for cutting Shingles, Headings, Etc. . .

It will pay you

to write for description and price before placing your order.

We also Manufacture a complete line of . . .

SAW MILL MACHINERY, ENGINES AND BOILERS

THE **Owen Sound Iron Works Co. LIMITED**

Owen Sound, Ont.

SEND FOR CATALOGUE

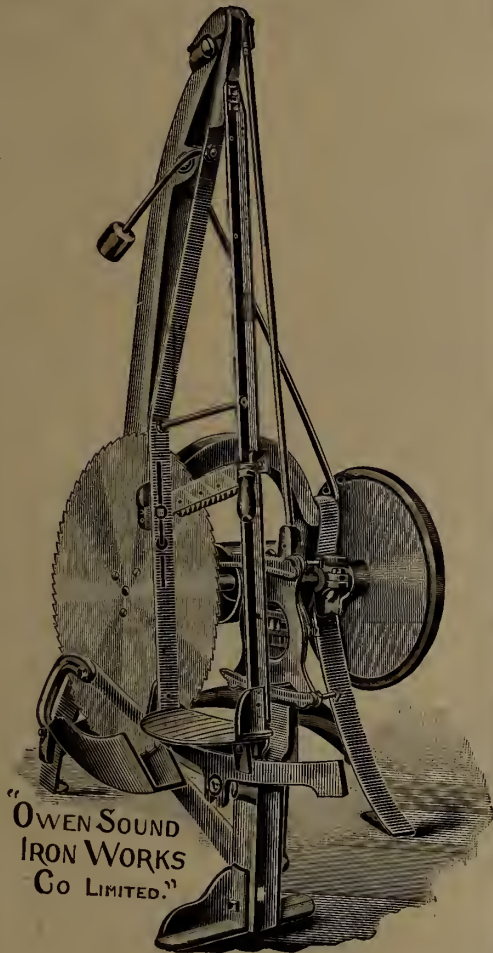

"OWEN SOUND IRON WORKS CO LIMITED."

RUBBER BELTING

For Transmitting Elevating and Conveying



Rubber Hose for Water Steam Air Suction Fire Protection

THE GUTTA PERCHA & RUBBER MFG. CO. OF TORONTO, LIMITED.

HEAD OFFICES: 47 YONGE STREET, TORONTO, CAN.

Branches: Montreal, Winnipeg, Vancouver.

New 200 Page Green Book 1904 EDITION.

"Saw and Knife Fitting Machinery and Tools"

MAILED FREE ON REQUEST.

A Book for Mill and Factory Managers, Superintendents, Foremen and Saw Filers.

BALDWIN, TUTHILL & BOLTON, GRAND RAPIDS, MICH., U.S.A.



B. T. & B. Full Automatic Knife Grinder. Style D

SAW AND KNIFE FITTING

THE NEW B. T. & B. MANUAL

Revised edition. 144 pages. Copiously illustrated and Durably Bound. Is an exhaustive treatise on the care of Saws and Knives.

A Practical Book for Saw Filers.

Mailed Postpaid on Receipt of Price

\$2.00

THE "B. T. & B." LINE

NEED ANYTHING?

- Sharpeners, Swages, Stretchers, Shapers, Side Files, Shears, Retoothers, Brazing Machines, Filing Clamps, Lap Grinders, Lap Cutters, Patch Machines, Crack Drills, Hammering Benches, Bench Grinders, Band Filers, Band Setters, Pulleys and Stands, Brazing Forges, Saw Sets, Saw Gauges, Swage Bars, Upsets, Straight Edges, Tension Gauges, Back Gauges, Leveling Blocks, Anvils, Hammers, Speed Indicators, Emery Dressers, Knife Grinders, Knife Balances, Shingle Saw Grinders, Burr Gummers, Post Brackets, Stretcher Bench Brackets, Cutters, Marking Stamps, Saw Guides, etc.

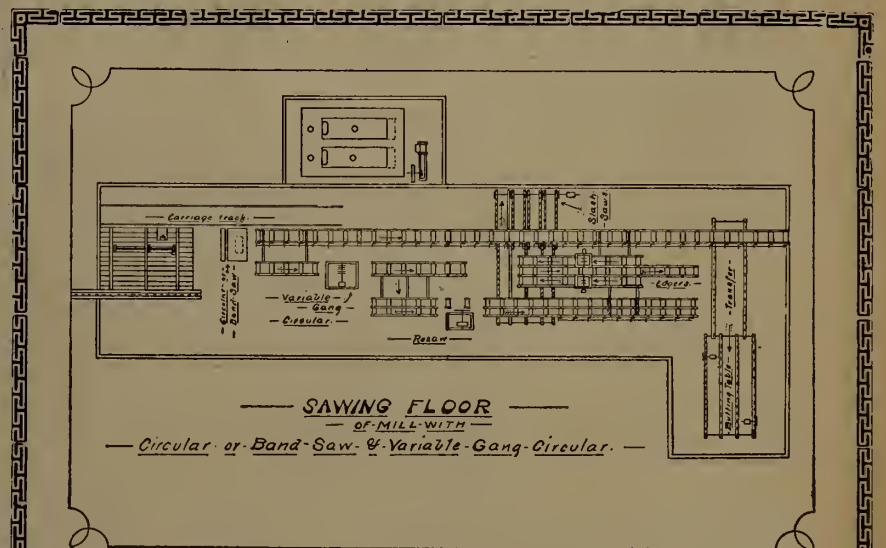

Sawing Floor of Mill with Circular or Band Saw and Variable Gang Circular

For cutting large and small logs at the same time, profitably, this mill has no equal. The variable Gang Circular (which takes the place of an upright gang) cuts the cants into any thickness from 1" to 9" by whatever width the cant has been slabbed to up to 10", and each cant put through may be cut into different sizes from the one immediately preceding or following it. Plans and estimates made of all kinds of sawmill work; machinery supplied and mills built if desired.

I. N. KENDALL

203 BRIDGE ST.

OTTAWA, ONT.

ADAM HALL,

PETERBOROUGH, ONTARIO
CANADA

MANUFACTURER OF . . .

STEEL RANGES

For Lumbermen's and Railway Camps, Boarding Houses and Hotels

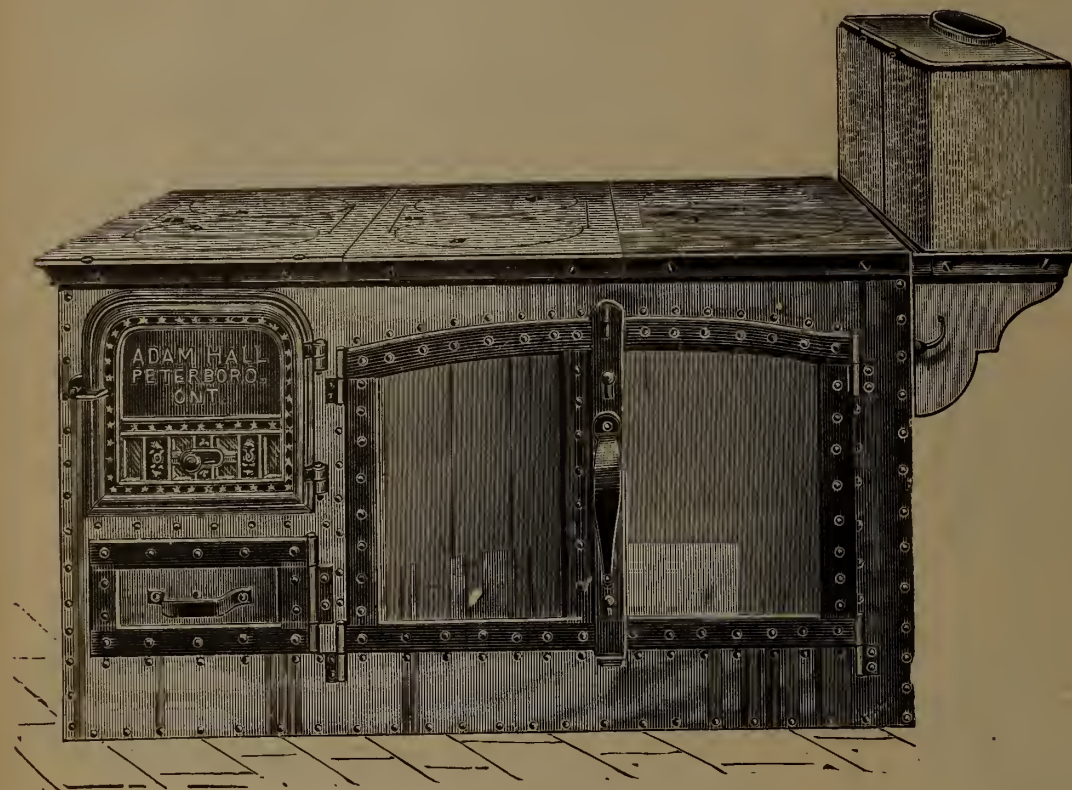

Lumbermen's Six Pot Hole Range with Reservoir.

The Lumberman Heater

36 Inch Lumberman Heater

42 Inch Lumberman Heater

48 Inch Lumberman Heater

This Heater is used in heating Lumbermen's Camps, Boarding Houses, School Houses and large buildings.

The body of the Heater is made of Heavy Boiler Plate. The ends are made of Heavy Cast Metal, with a large Fire Door.

It is a perfect Heater, and very durable.

We have been manufacturing Steel Ranges and Heaters for Lumber Camps for the past Twenty-four Years, and have supplied the wants of nearly all the Lumbermen in Quebec, Ontario and Manitoba—they are unexcelled for Baking and Cooking, and are strong and durable.

This No. 10-25 Range with 25 Gallon Copper Reservoir is the one we sell the most of, owing to the convenience of having a supply of hot water at all times. Will cook for 50 to 60 men. Weighs 450 pounds.

Write for Catalogue and Price List.

IMITATED BUT NEVER EQUALLED

40,000
Running in
Every Kind
of Timber



Perfect
in Material,
Workmanship
and Temper

GET THE GENUINE HOE CHISEL-TOOTH SAW

MADE ONLY BY

R. HOE & CO., 504 to 520 Grand Street, NEW YORK, N. Y., U.S.A.

NATURAL DRAFT
MOIST AIR . . . **DRY KILNS**

LUMBER TRUCKS and
TRANSFER CARS

Write for prices and particulars of the most simple and efficient Natural Draft Dryer on the market. Testimonials and list of users sent on application. Every square inch of heating surface is utilized to the uttermost and perfect ventilation and circulation is obtained by a very simple arrangement of ducts. Write for particulars to

SHELDON & SHELDON,
GALT, ONT.

FORMERLY McEACHREN HEATING & VENTILATING CO.



Experimenting with Dry Kilns
is an Expensive Luxury

Why keep on using a Kiln that has to be regulated with dampers, chimneys and complicated fans. Put in a Morton Automatic Moist Air Kiln and your Dry Kiln troubles will be ended. We do not sell a man a Dry Kiln to dry Mahogany and then tell him it will dry Basswood staves. Our thirty years experience in the Dry Kiln business yours for the asking.

Write to-day for Illustrated Catalogue "C"

The A. H. Andrews Co.

174-176 Wabash Avenue - - - CHICAGO, U.S.A.

Eby Machinery Co., Western Agents, 17-19 Main St., San Francisco, Cal.

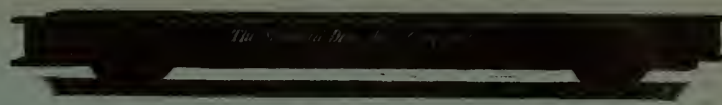

THE HIGHEST ACHIEVEMENT
IN TRUCK CONSTRUCTION

Standard Dry Kiln Trucks are best for your plant because they run more lightly, give less trouble and last longer than any other truck on the market. This we prove and guarantee.

Not only do they possess every modern feature of truck construction, but a number of the most valuable points about them are patented by us and cannot be reproduced in other trucks.

Standard Trucks have malleable iron wheels and spreaders; channel steel frame; steel rollers with cone-shaped ends that minimize the friction; lath-cut axles with milled ends, and many other advantages that are explained and illustrated in our printed matter.

Write for our Catalogue "D" and learn more about these better dry kiln trucks.

The Standard Dry Kiln Co.
Indianapolis, Indiana

SAW MILL OPERATORS are finding that

"MIDLAND" BEARING METAL

is all that WE CLAIM FOR IT

and then it is sold for only

15 CENTS A POUND

You will be pleased if you will give us a trial order

GEORGIAN BAY ENGINEERING WORKS

Midland, Ontario



FOR **DRY KILNS**

that will season lumber of all kinds and under all conditions, whether partially air-seasoned or green from the log, in shortest time and at least cost, entirely free from checking, warping or case hardening,

Write to—

McEACHREN HEATING & VENTILATING COMPANY, GALT, CANADA

HUTHER BROS. PATENT GROOVER OR DADO HEAD
For cutting any width groove from 1/4-inch to 2 inches or over

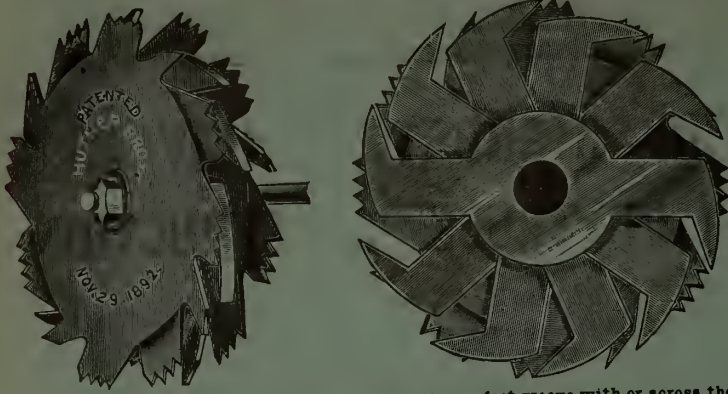

Can be used on any Circular Saw Mandrel. Will cut a perfect groove with or across the grain. This is the only Dado Head on the market that gives entire satisfaction on all classes of work. No screw adjustment. For different width grooves, simply remove or add inside cutters. Sold by builders and dealers of woodworking machinery in all parts of the United States. Will send on approval, in competition with any other make on the market; if not the best return at our expense HUTHER BROS., Platt Street, ROCHESTER, N.Y., manufacturers of Circular Saws, Morgan Pattern Lock-Corner Box Cutters, Concave Saws, etc.

LUMBERMEN'S LOG STAMPS
STEEL & RUBBER STAMPS, BRASS STENCILS, ETC.
THE SUPERIOR MFG. CO.
COR. BAY & ADELAIDE STS. TORONTO, CAN.
Write for Catalogue.

JNO. S. FIELDING, C. E.
WATER POWERS AND DAMS
Room 2, 15 Toronto Street - TORONTO

WIRE SCREENS

For every class of material
Perforated Metal of Steel, Copper, Brass, Zinc, for
all purposes
Special attention given to Miners' requirements

The B. GREENING WIRE CO., Limited
HAMILTON, ONT. - MONTREAL, QUE.



**AUTOMATIC
FEED PUMP AND
RECEIVER**

**STEAM and POWER
PUMPS**

**ENGINES
BOILERS**

**THE
SMART TURNER
MACHINE COMPANY**
Limited.
Hamilton - Ontario

Uncle Sam would not allow his battleships to be babbitted with inferior babbitt metal. New Battleship "Nebraska" is lined with Syracuse Babbitt. Always specify best. It is cheapest in the long run.

SYRACUSE SMELTING WORKS
MONTREAL - NEW YORK - SEATTLE

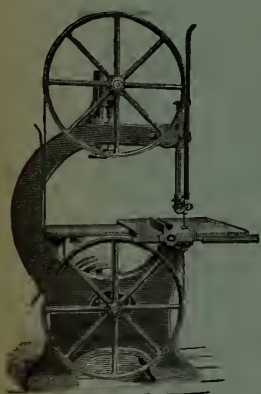

CRESCENT MACHINERY
Quality is all right.
So's the price.
**Band Saws
Jointers
Saw Tables**
Very low price on
BAND SAW BLADES
Catalogue tells the rest.
H. W. PETRIE
Dept. C. M.
TORONTO, ONT.



**THE
LEATHER
BELT
THAT'S
KNOWN
OUR
"EXTRA"**

**MONTREAL
WINNIPEG** **TORONTO
VANCOUVER**

PINK LUMBERING TOOLS

The Standard Tools

In Every Province of the Dominion, * * * * *
* * * * * New Zealand, Australia, Etc.



Pink Round Bill Peavey, Handles in Spli Maple

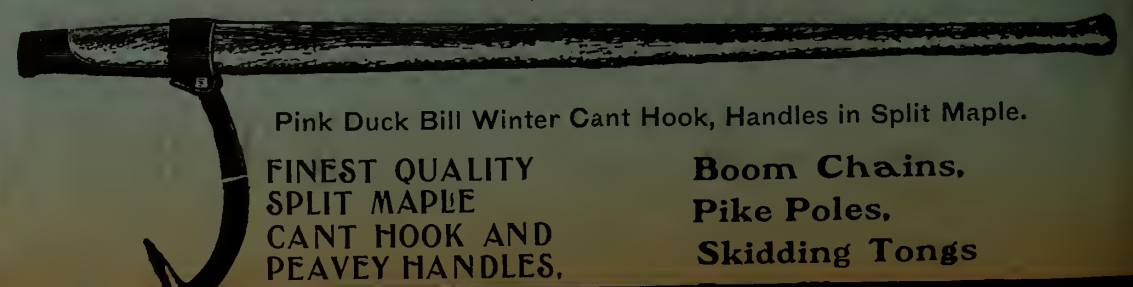

Pink Duck Bill Winter Cant Hook, Handles in Split Maple.

**FINEST QUALITY
SPLIT MAPLE
CANT HOOK AND
PEAVEY HANDLES,**

**Boom Chains,
Pike Poles,
Skidding Tongs**

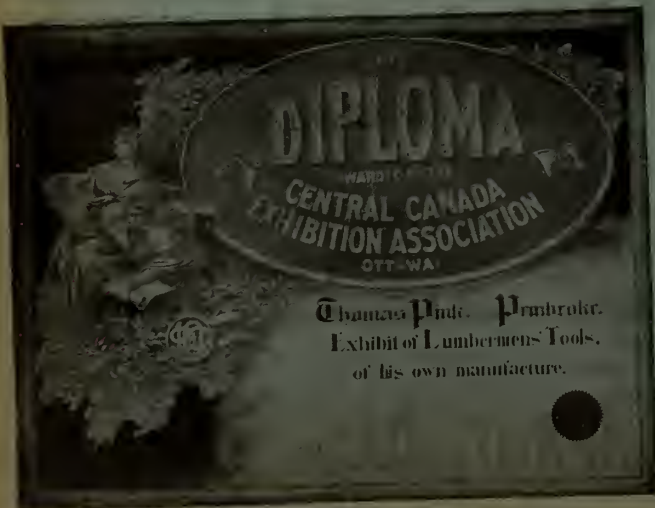

Thomas Pink, Pembroke.
Exhibit of Lumbermen's Tools,
of his own manufacture.

THOMAS PINK

THE CANADA LUMBERMAN AND WOOD-WORKER

REACHES REGULARLY MANUFACTURERS, BUYERS AND SELLERS OF TIMBER PRODUCTS IN EVERY PART OF CANADA AND LEADING IMPORTERS ABROAD

VOLUME XXV. }
NUMBER 10. }

TORONTO, MONTREAL — OCTOBER, 1905 — WINNIPEG, VANCOUVER

{ TERMS, \$1.00 PER YEAR
{ Single Copies, 10 Cents.

SNOW PLOWS

Logging Sleighs
Heavy Waggon

THE WILKINSON PLOUGH COMPANY, LIMITED
TORONTO, CANADA

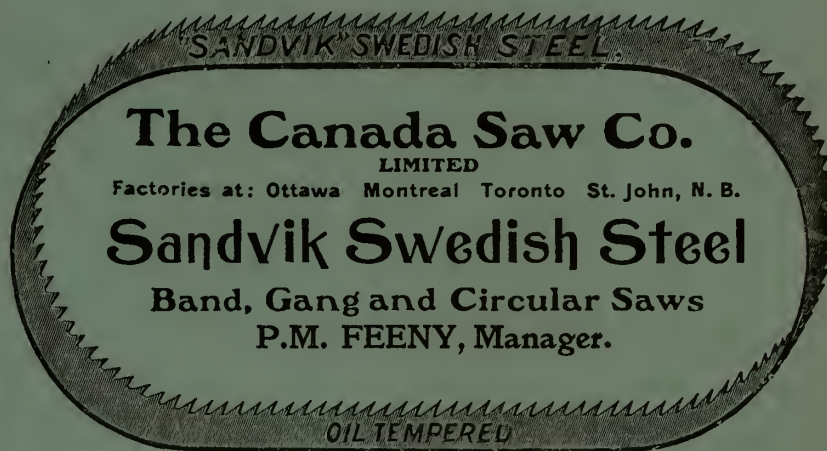

A Good Thing

A good thing is always worth the money. This is true of our belting.

J. L. GOODHUE & CO.,
DANVILLE, QUEBEC.

D. K. McLaren
GENUINE

Oak Belting
MILL SUPPLIES

751 Craig St., Montreal,
196 King Street West, Toronto
169 Prince William St., St. John, N. B.

WOODS LIMITED

Wholesale Manufacturers of . . .

LUMBERMEN'S AND CONTRACTORS' SUPPLIES

INCLUDING

Tents, Flags, Awnings, Tarpaulins, Clothing, Overalls, Shirts, Mitts, Underwear, Blankets, Axes, Moccasins, Woods Celebrated Eider Down Sleeping Bags

WOODS BUILDING - OTTAWA, CAN.

SEND FOR H. W. PETRIE'S
MONTHLY STOCK LIST
NEW & 2ND MACHINERY
TORONTO, CANADA

DICK'S BELTINGS



Never is affected by wetness, and does not stretch

Excels in Transmission Power

Always Uniform.

LARGE STOCK ON HAND

WRITE TO SOLE AGENTS:

J. S. YOUNG, 14 Hospital Street MONTREAL

HOISTING ENGINES

—FOR— Derricks,
—ANY— Winches, Wire Rope
and Fittings, Manila, etc.
—USE— W. H. C. MUSSEN & CO.
MONTREAL.

MANUFACTURERS OF

HIGH GRADE
CIRCULAR AND LONG SAWS
UNEXCELLED
SHINGLE SAWS



OUR INSERTED TOOTH SAW POSITIVELY THE BEST

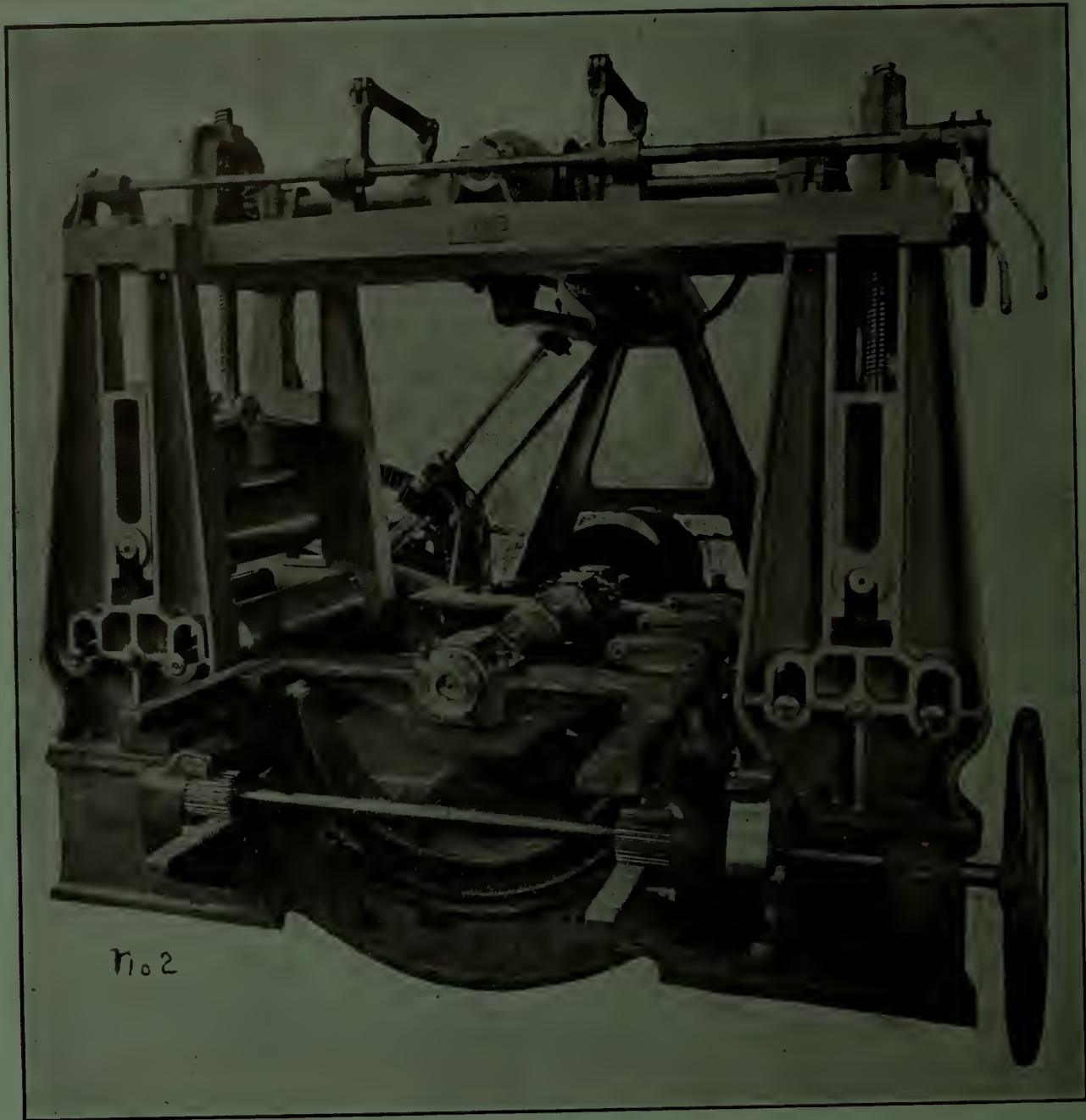

Kendall's Patent Variable Gang Circular

For sawing small logs from six to twelve inches diameter.

It has a capacity of easily seventy thousand feet of lumber in ten hours.

Is perfectly safe to the operator ; there has not been a single accident in over three years with this machine.

Lumber of varying thicknesses can be cut on this gang circular.

It is fully guaranteed as to the workmanship and material in same, and also as to its operation.

Write us for further particulars

The WM. HAMILTON MFG. CO., Limited
PETERBOROUGH, ONT., AND VANCOUVER, B.C.

Up-to-Date Sawmill Machinery

Head Offices :
MONTREAL.

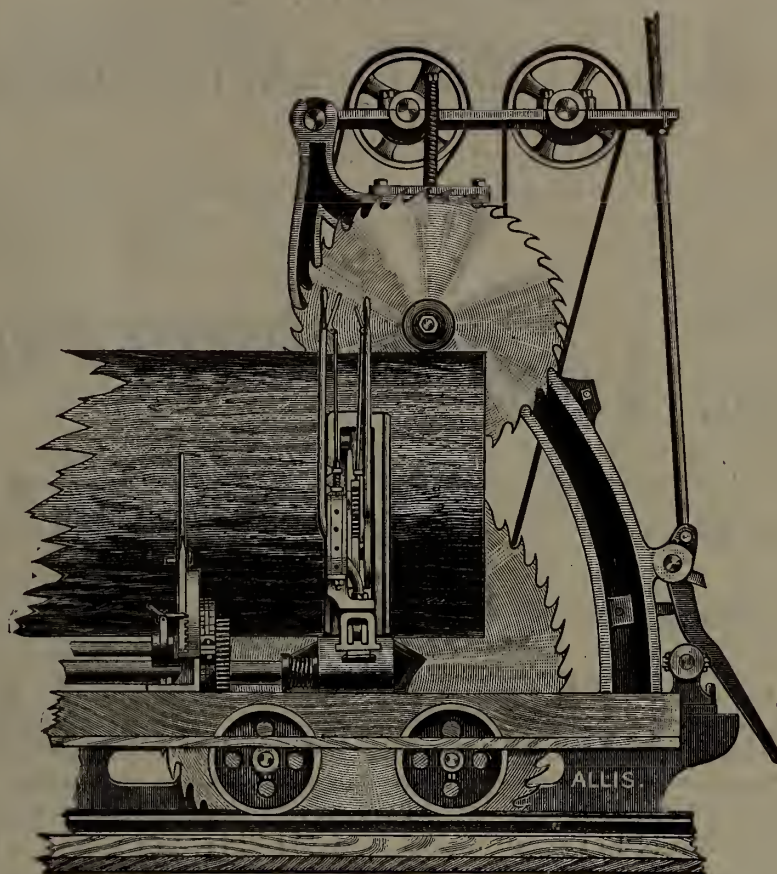

Branch Offices :
HALIFAX, TORONTO, WINNIPEG,
NELSON, VANCOUVER.

No. 1 Single Circular Mill with Inverted Top Saw Hanging.

Allis-Chalmers-Bullock, Limited



Simplex Shingle Packer

Easily adjusted from 24 to 28 inch bunch.

Side bars held firmly in place while packing. When end is turned down it releases side bars three-fourths of an inch and enables the bunch to be moved easily.

The frame that carries the side bars, also one that carries shaft, are of iron, making a firm or rigid frame.

MANUFACTURED ONLY BY

Letson & Burpee, Limited, Vancouver, B. C.

BRITISH COLUMBIA LUMBER AND SHINGLE MANUFACTURERS

The Canadian Pacific Lumber Co., Limited

PORT MOODY, B. C.

Manufacturers and Wholesale Dealers in All Kinds of

B. C. LUMBER, LATH, MOULDINGS, ETC.

Special Attention Given to Orders from Manitoba and the Territories



Long Distance Telephone Connection.



Address the Company at Port Moody or BYRNES & CUDDY, Selling Agents, WINNIPEG

PETER LUND, Managing Director.

J. BRECKENRIDGE, President.

MANUFACTURERS OF ALL KINDS OF

Grows Nest Pass Lumber Co., Limited

WARDNER, B. C.



BUILDING MATERIAL

Capacity 150,000 Feet Per Day.

Columbia River Lumber Company, Limited

HEAD OFFICE AT GOLDEN, B. C.

Largest Capacity in Mountains

MILLS AT { GOLDEN, B. C.
BEAVER, B. C.
KAULT, B. C.
CARLIN, B. C.

ROUGH AND DRESSED

LUMBER

FIR, SPRUCE
CEDAR AND PINE

LATH

Telephone Poles, Piling, Etc., a Specialty.

The Fernie Lumber Co., Limited, Fernie, B. C.

MANUFACTURERS OF AND DEALERS IN ALL KINDS OF

ROUGH AND DRESSED LUMBER

Dimension and Bridge Timber a Specialty.

Moulding in Stock or Made to Order.

JOS. GENELLE, Manager.

J. G. BILLINGS, Secretary.

THE YALE-COLUMBIA LUMBER COMPANY, LIMITED

Head Office: NAKUSP, B. C.

Mills at Nakusp, Westley and Cascade, B. C.

MANUFACTURERS OF

DEALERS IN

All Kinds Rough and Dressed Lumber, Mouldings, Lath, Etc.

Cedar and Fir Piles, Telephone and Telegraph Poles, Fence Posts, Etc.

NORTH STAR LUMBER COMPANY,

Head Office and Shipping Yards: ELKO, B. C.

Mills: CRANBROOK, B. C.

At present we have the following material in stock at Cranbrook, B. C.:

- 1,750,000 ft. Common Boards.
- 300,000 " Stock Boards, 8 in., 10 in. and 12 in.
- 300,000 " Shiplap, 8 in., 10 in. and 12 in.
- 100,000 " Flooring, Siding and Ceiling, 4 in. and 6 in.
- 1,550,000 " Dimensions, 8 to 24 ft.

We have a large quantity of 18 and 20 ft. lengths, from 2 x 4's to 2 x 12's.

The above is manufactured from a superior quality of pine, fir and tamarack logs. 75 per cent. of it is "bone dry."

Special sized timbers cut on short notice. Write for prices

MANUFACTURERS OF AND WHOLESALE

DEALERS IN



B. C. WHITE PINE LUMBER and LATH

Write Us About Our LARCH LUMBER

Factory Lumber
and
Tank Stock

A Specialty

RAYARD, B. C.

BRITISH COLUMBIA LUMBER AND SHINGLE MANUFACTURERS

FIR, CEDAR
and SPRUCE
LUMBER and
FINISH

PROMPT

FIR
TIMBER, Etc.
Dressed to 30 x 30 x 90



MOULDINGS
TURNINGS
and
LATH

SHIPMENTS

RED
CEDAR
SHINGLES

"Cascade Brand"
Always the Best

ADVERTISE YOUR WANTS IN

**Weekly
Canada
Lumberman**

Toronto Montreal Winnipeg

BLUE & DESCHAMPS

Manufacturers of

Tamarac, Hemlock, Spruce
Fir, Cedar and White Pine

MILL AND OFFICE: ROSSLAND, B. C.

China Creek Lumber Co., Limited

Manufacturers of

Fir, Tamarac and Yellow Pine

WE MAKE LATH

Mill at CHINA CREEK Office at ROSSLAND, B. C.

The MAYOOK LUMBER COMPANY, Limited

MANUFACTURERS OF

LARCH, PINE AND FIR TIMBER

Head Office: MAYOOK, B. C. WINNIPEG Office: 445 Main Street

Saw and Planing Mill at MAYOOK, B. C.



CEDAR LUMBER

Manufacturers and Shippers

Cedar, White Pine, Fir
Lumber, Lath, Mouldings, Shingles

Bowman Lumber Co., Ltd.
Revelstoke, B. C.

Mills at { REVELSTOKE, B. C.
COMAPLIX, B. C.

ROSS BROS & CO.

FORMERLY OF WHITEMOUTH, MAN.

SUCCESSORS TO THE ELKMOUTH LUMBER CO.
ELKMOUTH, BRITISH COLUMBIA

Full Lines Kept in

Pine, Fir and B. C. Tamarac

ORDER RESPECTFULLY SOLICITED

Send for Our Prices

Advertisements in the CANADA LUMBERMAN bring results—try one.

THE EAST KOOTENAY LUMBER CO., Limited

Saw and Planing Mills at Ryan, Cranbrook and Jaffray, B. C.

Capacity, 150,000 Feet Per Day

MANUFACTURING

LARCH

PINE and FIR

Lumber, Timber, and all kinds
of Mouldings, also dealers in
Railway Ties, Piles and Poles

Large Stocks of Well Seasoned Dry Material Always on Hand

HEAD OFFICE CRANBROOK, B. C.

USE MUNDY'S QUALITY

AIR DRIED LUMBER AND SHINGLES

— THREE VALLEY, B. C.

The Ladysmith Lumber Co., Limited

LADYSMITH, B. C.

Manufacturers of

LUMBER, LATH, SHINGLES, MOULDINGS, ETC.

SPECIALTY: The best Cedar Shingles manufactured on the Coast.

FRESH WATER FIR LATH ALWAYS IN STOCK.

Capacity of Shingle Mill, 100,000 per day of 10 hours.

Correspondence Solicited

**The Cook & Bros.
Lumber Co.**

Of Ontario, Limited
MILLS at SPRAGGE, Algoma Dist., Ont.
on "Soo" Branch C.P.R.

OFFICES { Manning Arcade, Toronto
Coristine Building, Montreal
And at Mills at Spragge.

MANUFACTURERS OF

**White and Red Pine
Lumber and Lath**

Water Shipments

**For Fans, Separators, Dust Collectors
Blowers and Shavings Systems
Heating and Dry Kiln Systems**

SEND FOR CATALOGUE TO

HINRICH & PACE

Revelstoke, B. C.

Get Rid of Your Trouble

with Gears, which are eating up too much of your power, by putting in a **Horizontal Setting** as shown here. This is the **Modern Way** and also the **Economical Way**, for it will save you **Water, Power, Time and Money**. This cut shows a **Globe case** containing a **Triumph Turbine**, with elbow, two pulleys, one of which may be cut off by a clutch, and governor, all mounted on the one steel frame. This setting is self-contained, rigid and durable, and permits a direct belt drive to the machine to be driven.

Our **Triumph Wheels** placed horizontally give from 5 to 10 per cent. better results than any other wheel, owing to their perfect discharge. For light powers with limited water our **Improved Standard Leffel and Vulcan Wheels** have no equals. If you are developing a new power or replacing an old setting, let us figure with you. We can furnish any style of setting for any head or power, and our experience in this line is at your service.

We also build the **Improved Lane Circular Saw Mills** with capacities of from 5 to 50 M. per day, **Shingle Machines**, and all **Machinery** for making lumber, lath or shingles.

Our new **Tie Machine** will make 1200 Ties in 10 hours. It's worth investigating.

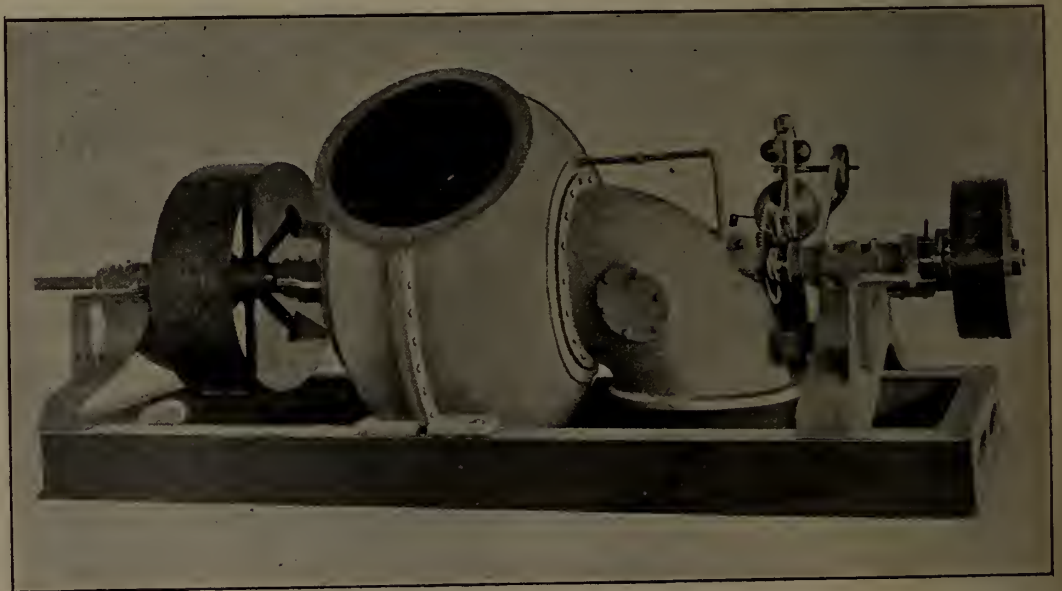

MADISON WILLIAMS

H. E. PLANT, Agent
Cor. Common and Nazareth Streets
Montreal, Que.

Successor to Paxton, Tate & Company
PORT PERRY, ONT.

Manitoba Iron Works
Western Selling Agents
Winnipeg, Man.

Merit Always Wins

Investigate Our Claims Regarding Superiority. We Can Convince You.

Read What One of Our Latest Converts Says:

"Find enclosed statement and check to balance account in full. We are pleased even beyond our expectations with the resaw. We have been using, as you know, another make of resaw for some years which was very satisfactory, but your machine does so much more and better work, taking apparently no more power, that we are only sorry we haven't one of your machines in place of the other. Besides that our filer says that he can keep your saws in shape with about half the labor that he can on the other machine.

Write Us regarding any Wood Working Machine you may need.

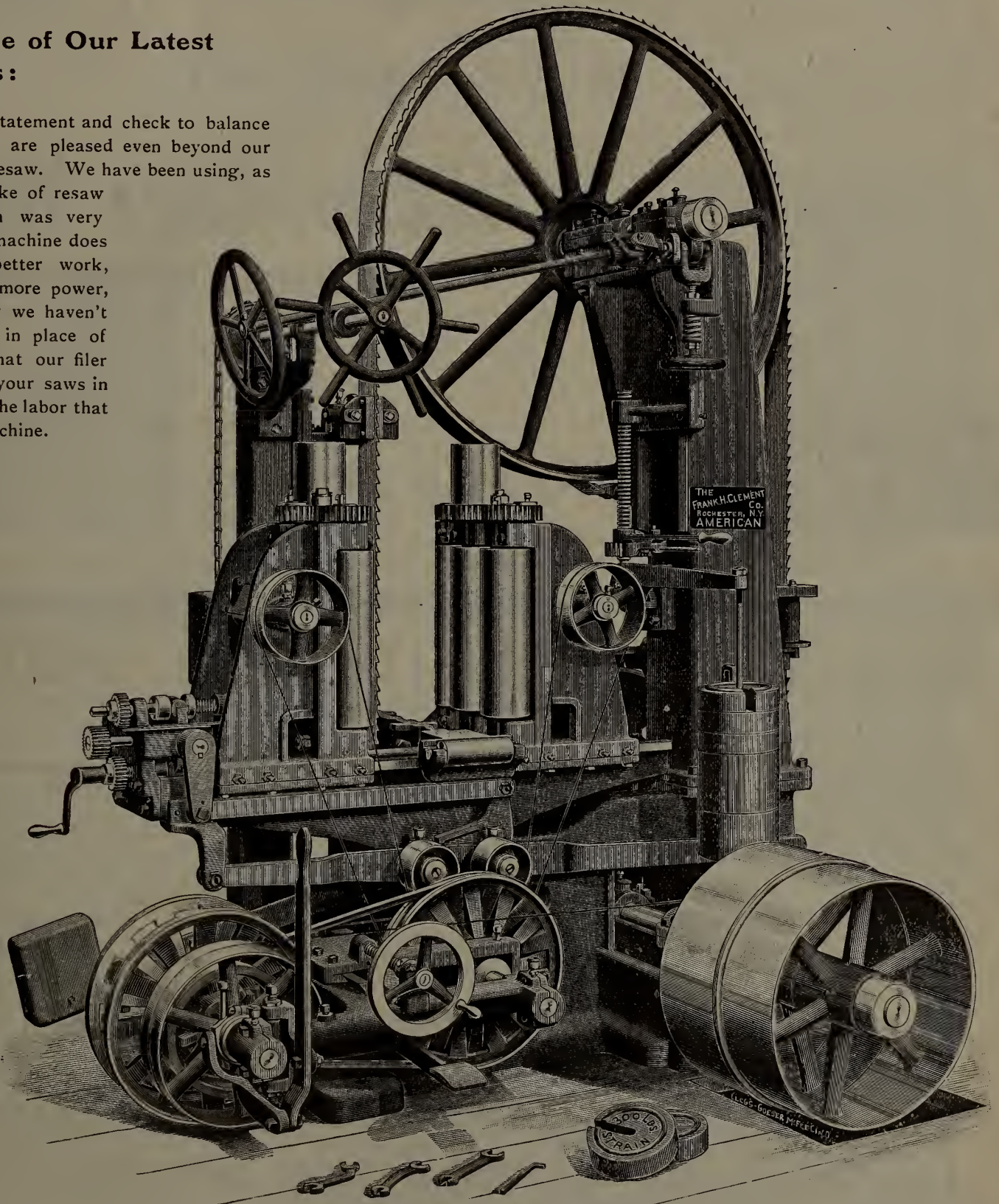

A Clement 48", 54" and 60" Band Resaw.



American
Wood Working Machinery Co.
 NEW ORLEANS CHICAGO NEW YORK



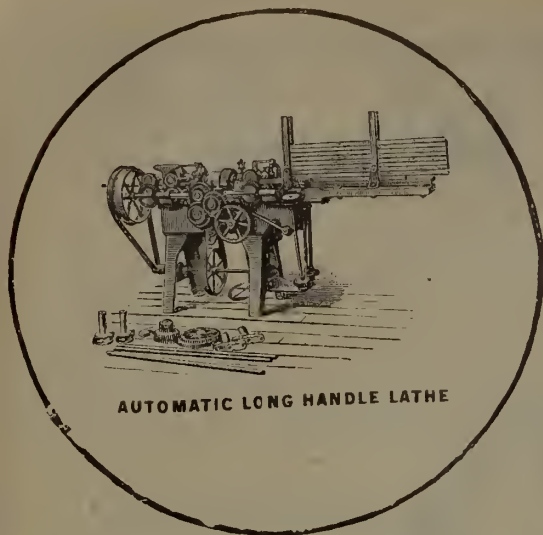

AUTOMATIC LONG HANDLE LATHE

**"DEFIANCE"
Wood--Working Machinery**

For Manufacturing
**HUBS, SPOKES, WHEELS, WAGONS,
CARRIAGES, RIMS, SHAFTS, POLES,
NECK-YOKES, SINGLETREES, BARREL
HOOPS.**

Handles of Every Kind, Insulated Pins, Spools,
Bobbins, Oval Wood Dishes, and General Wood-
Work.

Invented and Built by

THE DEFIANCE MACHINE WORKS,
Defiance, Ohio, U. S. A.



12" RIM, HOUND AND BOW BENDER



The **"Alligator"** Steam Warping Tugs

SIDE WHEELS OR TWIN SCREWS

The Twin Screws are arranged with flexible joint to
raise up in crossing portage

MANUFACTURED BY

WEST & PEACHEY, - Simcoe, Ont.

Cables carried in stock for renewals

THE E. LONG MANUFACTURING CO., ORILLIA, ONT.

THESE SAW CARRIAGES ARE MADE OF CAST STEEL, AND OPEN 36 TO 54 IN. FROM SAW.

We build Double Edgers, Steam Feeds, Log Jacks, Live Rolls, Trimmers, Slab Slashers, Steam Niggers.

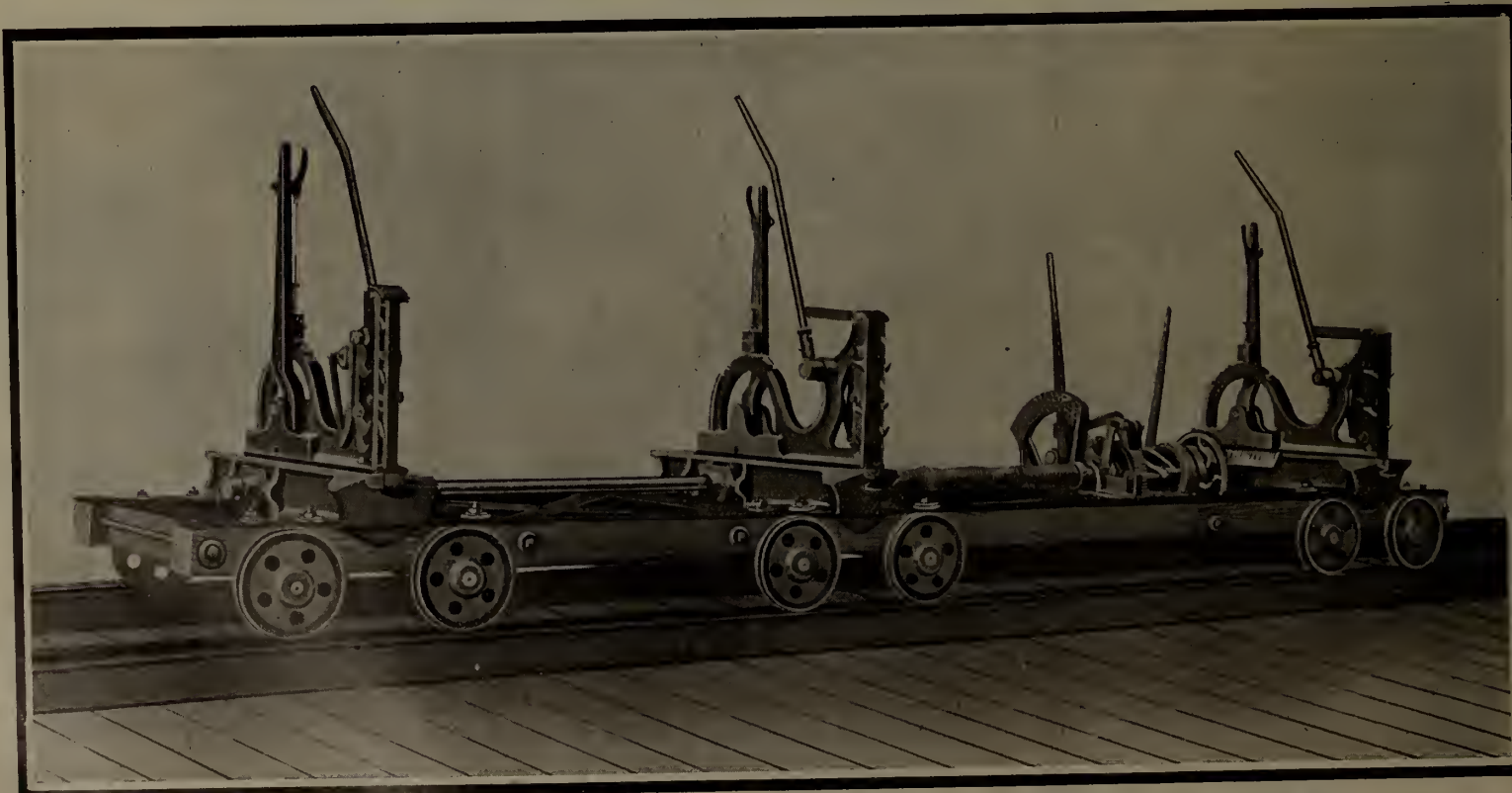

COMPLETE LINE OF SAW AND SHINGLE MILL MACHINERY
WRITE FOR CATALOGUE AND PRICES

R. H. SMITH CO., LIMITED

— St. Catharines, Ont. —

We are the Sole Manufacturers of Saws
under the

Simond's Process

in the Dominion of Canada.

There is no process its equal for tempering circular saws. Other makers recognize this fact, as some of them, in order to sell their goods, claim to have the same process. All such Claims are FALSE, as the patentee in the U. S. and ourselves are the only firms in the world who use it.



INSERTED TOOTH SAWS

Notice the improved shank. We call particular attention to the swell which strengthens it at the weakest part and which gives it more wear than the old style.

Shanks made in usual gauges and to fit your saws perfectly.

SHINGLE SAWS

The quality of the "Simonds" Shingle Saws is proven by the fact that the largest shingle and machine manufacturers in Canada are using them.

Run a "Simonds" and you will increase your output.



CROSS-CUT SAWS

THE "NARROW LEADER"

REFINED SILVER STEEL.

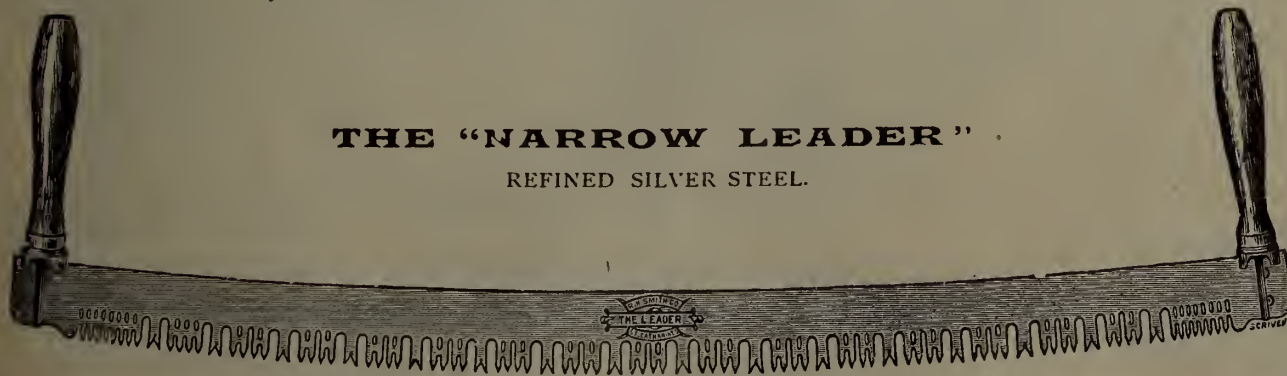

The Simond's temper and style of tooth make the "Leader" the fastest and easiest cutting saw manufactured.

Write for prices.

R. H. SMITH CO., Limited, St. Catharines, Ont.

CLASSIFIED INDEX OF ADVERTISERS

AXES
 Dundas Axe Works..... 39
 Warnock Co., James..... 40

ALLIGATOR TUGS
 West & Peachey..... 8

BELTING
 Beal Leather Co., R. M..... 39
 Dominion Belting Co..... 31
 Gutta Percha & Rubber Mfg. Co..... 41
 Goodhue & Co., J. L..... 1
 McLaren, D. K..... 1
 McLaren Belting Co., J. C..... 44
 Montreal Belting Co..... 11
 Waterous Engine Works Co..... 31
 Wilby, P. H..... 12
 Young, J. S..... 1

BABBITT METALS
 Georgian Bay Engineering Works... 43
 Syracuse Smelting Works..... 44

BOILERS
 Dymont Foundry Co..... 36
 John McDougall Caledonian Iron Works 30

DOORS
 New Century Refrigerator & Mfg. Co. 10

DRY KILNS
 Andrews Co., The A. H..... 43
 McEachren Heating & Ventilating Co. 43
 Sheldon & Sheldon..... 43
 Standard Dry Kiln Co..... 43

EMERY WHEELS
 Hart Corundum Wheel Co., Limited.. 28

ENGINES AND LOCOMOTIVES
 Dymont Foundry Co..... 36
 Gartshore, John J..... 10
 Robb Engineering Co..... 37

EDGERS
 Gordon Hollow Blast Grate Co..... 37

GRATES
 Gordon Hollow Blast Grate Co..... 37

LUMBERMEN'S SUPPLIES
 Beal Leather Co., R. M..... 39
 Barr, Alex..... 12
 Capstan Mfg. Co..... 39
 Johnson, A. H..... 37
 Park, Blackwell Co..... 39
 Thompson Mfg. Co..... 31
 Tobin, Joshua..... 28
 Woods, Limited..... 1

LUMBER AND SHINGLE MANUFACTURERS
 Bowman Lumber Co..... 6
 Cook & Bro. Lumber Co..... 6
 Canadian Pacific Lumber Co..... 4
 China Creek Lumber Co..... 5
 Crows Nest Pass Lumber Co..... 4
 Columbia River Lumber Co..... 4
 Cascade Mills..... 5
 East Kootenay Lumber Co..... 5
 Fernie Lumber Co..... 4
 Ladysmith Lumber Co..... 6
 Mundy Lumber Co..... 6
 Mayook Lumber Co..... 5
 North Star Lumber Co..... 4
 Ross Bros. & Co..... 5
 Staples, Otis..... 4
 Yale-Columbia Lumber Co..... 4

LUMBERMEN'S TOOLS
 Baldwin, Tuthill & Bolton..... 41
 Hay Knife Co., Peter..... 22
 Pink, Thomas..... 44
 Warnock Co., James..... 40

LUMBERMEN'S AGENTS
 Friel, H J..... 31
 Wright, H J..... 31

MISCELLANEOUS
 Alexander Engraving Co..... 39
 Bradstreets..... 10
 Canadian Office & School Furniture Co.. 10
 Clyde Iron Works—Log Loaders... 38
 Denton, Dunn & Boulton, Barristers. 11
 Fielding, J. S., Consulting Engineer.. 44
 Georgian Bay Engineering Works—
 Grinders..... 43
 Huther Bros.—Dado Heads..... 44
 Lumber Mutual Fire Insurance Co..... 34

Manitoba Gypsum Co.—Plaster..... 11
 Midland Engine Works Co.—Tram
 Car Wheels..... 12
 Superior Mfg. Co.—Log Stamps..... 44
 Spence & Co., R.—Files and Rasps.. 10
 Saw Gummer, A. T. McLatchie..... 31
 Sessenwein Bros.—Rails..... 29
 Toledo Fire Insurance Co..... 33
 Vogel, C. H.—Pulp Mill Engineer.... 31

OILS.
 Commercial Oil Co..... 31
 Canadian Oil Co..... 22
 Queen City Oil Co..... 10

PROVISIONS
 Eckardt & Co., H.P..... 27

PORTABLE SAW MILLS
 Drake, F. J..... 36

PLANERS AND MATCHERS
 Cowan & Co..... 35

PACKING AND PIPE COVERING
 Garlock Packing Co..... 12
 Purvis Co., E. L..... 31

ROPE
 Consumers Cordage Co..... 34
 Dominion Wire Rope Co..... 12
 Greening Wire Co., B..... 44
 Mussen & Co., W. H. C..... 1

ROOFING
 Bird & Son, F. W..... 31

RE-SAWS
 Cowan & Co..... 35

SAW SWAGES
 Hanchett Swage Works..... 29

SAW GAUCES
 Specialty Mfg. Co..... 31

SAWS
 Atkins & Co., E. C..... 38
 Burns Saw Co., E. R..... 1
 Hoe & Co., R..... 11
 Smith Co., R. H..... 9

SAW MILL MACHINERY
 Allis-Chalmers-Bullock..... 3
 Furniture City Tool Co..... 39
 Gordon Hollow Blast Grate Co..... 39
 Hamilton Mfg. Co., Wm..... 2
 Hinrich & Pace..... 6
 Jenckes Machine Co..... 38
 Kendall, I. N..... 41
 Long Mfg. Co..... 8
 Lloyd Mfg. Co..... 8
 Manitoba Iron Works..... 34
 Mowry & Sons, B. R..... 38
 Petrie, H. W..... 1
 Payette & Co., P..... 34
 Smart-Turner Machine Co..... 44
 Waterous Engine Works Co..... 42
 Williams, Madison..... 6

SHINGLE MILL MACHINERY
 Drake, F. J..... 36
 Letson & Burpee..... 3
 Long Mfg. Co., E..... 8
 Williams, Madison..... 5

STOVES
 Hall, Adam..... 11

TURBINES
 Jenckes Machine Co..... 38
 Williams, Madison..... 6

TRIMMERS
 Gordon Hollow Blast Grate Co..... 37

WOODWORKING MACHINERY
 Adde & Co..... 31
 American Woodworking Machinery
 Co..... 7
 Connell & Dengler Machine Co..... 37
 Cowan & Co., Limited..... 35
 Defiance Machine Works..... 8
 Perkins & Co..... 12
 Rogers Iron Mtg. Co..... 35
 Sherman Co., W. S..... 37
 Shimer & Sons, Samuel J..... 41
 Waterous Engine Works Co..... 42

The . . .
QUEEN CITY OIL CO. LIMITED
 Head Office: TORONTO.

HIGHEST GRADES OF
Refined Oils
Lubricating Oils
 AND ALL
Petroleum Products

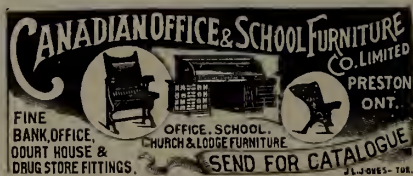

ESTABLISHED 1849.
BRADSTREET'S
 Capital and Surplus, \$1,500,000.
 Offices Throughout the Civilized World.
 Executive Offices:
 Nos. 346 and 348 Broadway, NEW YORK CITY, U.S.A.
 THE BRADSTREET COMPANY gathers information that reflects the financial condition and the controlling circumstances of every seeker of mercantile credit. Its business may be defined as of the merchants, by the merchants, for the merchants. In procuring, verifying and promulgating information, no effort is spared, and no reasonable expense considered too great, that the results may justify its claim as an authority on all matters affecting commercial affairs and mercantile credit. Its offices and connections have been steadily extended, and it furnishes information concerning mercantile persons throughout the civilized world.
 Subscriptions are based on the service furnished, and are available only by reputable wholesale, jobbing and manufacturing concerns, and by responsible and worthy financial, judiciary and business corporations. Specific terms may be obtained by addressing the company or any of its offices. Correspondence invited.
THE BRADSTREET COMPANY.
 OFFICES IN CANADA: Halifax N.S. Hamilton, Ont. London Ont.; Montreal, Que.; Ottawa, Ont.; Quebec, Que.; St. John, N. B. Toronto, Ont. Vancouver, B.C.; Winnipeg, Man.
 THOS. C. IRVING,
 Gen. Man. Western Canada, Toronto

RAILS For Logging Tramways, Switches, Etc.
YARD LOCOMOTIVES New and Second-Hand.
 John J. Gartshore
 83 Front St. West,
 (Opposite Queens Hotel), Toronto.

R. SPENCE & CO.
 Beech File Works.
HAMILTON, ONT.
FILE AND RASP MANUFACTURERS AND RE-CUTTERS
 A trial order solicited. Write for price list and terms.
 C. P. MOORE, PROPRIETOR.



New Century Refrigerator & Manufacturing Co., Limited
 Dudas, O., Can.

Our Business is Manufacturing
HARDWOOD VENEER . . . DOORS
 With Built Up Bodies

These Doors are guaranteed not to warp or twist and are superior in construction and finish to any other Door on the market.
 Send for Illustrated Catalogue and Prices.
 Special attention given to Architects' Designs of Doors and Trims.

AGENTS WANTED EVERYWHERE. ADDRESS DOOR DEPARTMENT

FRANK DENTON, K. C. HERBERT L. DUNN
W. MULOCK BOULTBEE.

DENTON, DUNN & BOULTBEE

Barristers, Solicitors, Notaries, etc.
National Trust Chambers. TORONTO

DO YOU USE IT?

BAUGHMAN'S BUYER & SELLER

THE HANDY BOOK FOR LUMBERMEN

Saves half the time and all the mistakes in figuring Invoices, Estimates and Inventory. Send for sample copy.

Flexible Cloth \$1.00
Flexible Leather 1.25

Sample Page Free. Address

H. R. H. BAUGHMAN
INDIANAPOLIS, IND, U. S. A.

MONTREAL BELTING CO.

595 St. Paul St., MONTREAL

Manufacturers
ENG'ISH OAK TANNED
LEATHER BELTING

Discounts 60, 10 and 5 Off Lists

DO NOT

underestimate the importance of checking your figures when ascertaining contents of cut material in 1/4, 5/4, 6/4 or 8/4 lumber, or surface measure for veneers, etc., for boxes, mill work, furniture, etc. Save time, labor, brainwork, and prevents errors by using the comprehensive, successful and highly recommended "Box Estimator" which gives results, decimally expressed, at a glance.

Sent on Trial.

J. M. LEAVER,
Sault Ste. Marie, Mich.

The Manitoba Gypsum Co.

LIMITED

MANUFACTURERS OF

HARDWALL PLASTER WOOD FIBRE PLASTER
PLASTER OF PARIS STUCCO ALABASTER
and All Kinds of Gypsum Products

The Only Plaster Co. in Western Canada

Quality of goods superior to any imported article, our mill being equipped with the latest improved machinery.

Dealers are invited to get our quotations before placing orders for Spring requirements

Office: 811 UNION BANK BUILDING, WINNIPEG

D. E. ROBERTS Lately in charge of the Plymouth
Plaster Co., at Fort Dodge, Iowa.
Superintendent of Manufacture

WM. MARTIN
General Manager

THE ORIGINAL AND ONLY PERFECT
CHISEL-TOOTH SAW

ALL OTHERS ARE IMITATIONS.



GOLD MEDAL (HIGHEST AWARD)
ST. LOUIS, 1904.

SEND FOR NEW ILLUSTRATED CATALOGUE,
WITH NEW PRICES AND NEW DISCOUNTS.

R. HOE & CO.

504-520 GRAND STREET,
NEW YORK, N. Y.

A. D. A. M. H. A. L. L.

PETERBOROUGH, ONTARIO
CANADA

MANUFACTURER OF

STEEL RANGES

For Lumbermen's and Railway Camps, Boarding Houses and Hotels

The Lumberman Heater

- 36 Inch Lumberman Heater
- 42 Inch Lumberman Heater
- 48 Inch Lumberman Heater

This Heater is used in heating Lumbermen's Camps, Boarding Houses, School Houses and large buildings.

The body of the Heater is made of Heavy Boiler Plate. The ends are made of Heavy Cast Metal, with a large Fire Door.

It is a perfect Heater, and very durable.

We have been manufacturing Steel Ranges and Heaters for Lumber Camps for the past Twenty-four Years, and have supplied the wants of nearly all the Lumbermen in Quebec, Ontario and Manitoba—they are unexcelled for Baking and Cooking, and are strong and durable.

This No. 10-25 Range with 25 Gallon Copper Reservoir is the one we sell the most of, owing to the convenience of having a supply of hot water at all times. Will cook for 50 to 60 men. Weighs 450 pounds.

Write for Catalogue and Price List.



Lumbermen's Six Pot Hole Range with Reservoir.

TEON BELTING



STEAM PPOOF
 WATER "
 HEAT "
 OIL "
 ACID "

Stronger and Cheaper than Leather.

LEATHER BELTING

GAPATA BELTING [BALATA TYPE]

CAMELS HAIR BELTING

LACE LEATHER, ETC.

Special Arrangements for Trial Belts.
Write for Price Lists and Discounts.

P. H. WILBY, 27 1/2 Front Street East, TORONTO

Phone Main 1930.

SOLE AGENT FOR CANADA.

Our special

Tram Car Wheels



made from a special mixture of Iron, are stronger, longer lived, low in price and lighter for their strength than any other wheel. Write for prices and samples of metal.

MIDLAND ENGINE WORKS CO.
MIDLAND, ONT.

LARGE STOCK CARRIED & CUT TO ANY LENGTH
BLOCKS, CLIPS, TURNBUCKLES, ETC.

WIRE ROPE

SPECIAL ROPES FOR LUMBERING
DOMINION WIRE ROPE Co., LTD
MONTREAL, QUE.

EVERY LUMBERMAN WANTS IT

35 cents buys it

Scribner's Lumber and Log Book

BRIMFUL OF EVERY-DAY
PRACTICAL INFORMATION

Address:
THE CANADA LUMBERMAN, Toronto

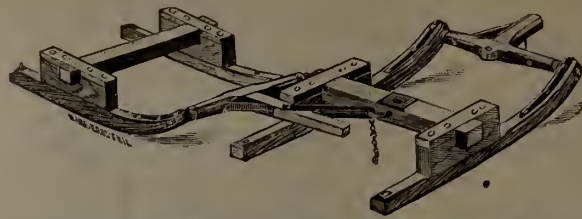

THE LUMBERMEN'S FRIEND

(Desjardin's Patent)
ALSO

Heavy Runners for Logging Sleighs
Bent to Order, Poles, Beams, Rollers,
Blocks, and other parts on hand at all times.

I ALSO MAKE
Boom Chains
Logging Chains
Skidding Tongs
Clevis' Heavy
Neckyokes and
Whiffletrees

Large
DUMPING WAGONS
for Mill Yards a
Specialty

ALEX. BARR

WRITE FOR PRICES

Manufacturer

Pembroke, Ont.



The Most Perfect Shingle Machine

in the world—the fastest, easiest operated, safest and strongest, is shown herewith.

THE Columbia Single-Blocker

will not only make more and better shingles in less time than any other shingle machine, but "IT WILL PRODUCE 1,000 ADDITIONAL SHINGLES FROM EVERY 1,000 FEET OF LOGS." Let's prove this to you. Write

PERKINS & GO. - GRAND RAPIDS, MICHIGAN



Garlock Packing Co.

HAMILTON - - - CANADA

—SOLE MANUFACTURERS OF—



GARLOCK'S PACKINGS

PATENTED

Asbestos and Mineral Wool Pipe and Boiler Coverings, Engineers' Supplies in General



THE CANADA LUMBERMAN AND WOOD-WORKER

VOLUME XXV.
NUMBER 8.

TORONTO, MONTREAL — OCTOBER, 1905 — WINNIPEG, VANCOUVER

TERMS, \$1.00 PER YEAR
Single Copies, 10 Cents

LUMBERING IN NEWFOUNDLAND

Much attention has of late years been paid to the development of the lumber industry in Newfoundland by the lumbermen of the Eastern provinces and the New England states. A vast amount of capital has been invested and a large amount of work already done, the investments in the majority of cases being productive of first class returns, while in others, owing to the greed of the speculator, or the inability of the operator to grasp actual and indisputable facts in connection with the forest wealth of the land, but poor returns have resulted.

In order to give the reader an accurate idea of the possibilities that lie before the industry, it is necessary to bear slightly upon the physical character of the country. The land embraces an area of 42,000 square miles, one third of this being taken up by rivers and lakes. Twenty-one thousand square miles are occupied by rough, broken, and swampy ground, unfit for cultivation, while the remaining 7,000 square miles are considered fit for agricultural operations. While in making this estimate we are aware that a large section of the island is yet to be explored, yet it can be assumed as approximately correct, because the productive lands are all in the river and lake valleys, all of which have been more or less explored, and it is in these districts that the largest areas of lumber are found. The highlands are generally destitute of soil, or possess soil of such character that the vegetation consists chiefly of moss or stunted growths of spruce and fir.

The timber belt exists principally in the north-eastern part of the Island and along the Exploits River and its tributaries, the Gander River and Lake, the Gambo, the Humber River, and the various rivers flowing into St. Georges Bay and the Bay of Islands and also the entire west coast. The largest spruce on the Island is at White Bay, where there is a large quantity of excellent growth. The northern peninsula opposite Labrador has not as yet been much explored, but it is thought to contain vast quantities of pulp wood. The southern and south-west

coast are entirely destitute of forest growth of any size.

The products of the forest are varied, the chief lumber being spruce, white pine, yellow pine, red pine, fir, juniper, birch, witch hazel, aspin, and white maple. The spruce is an invaluable wood for rough work and of admirable strength, although immense areas of it are exceedingly small and suitable only for pulp wood and railway sleepers. Many reasons are given to account for the diminutive



LUMBERING IN NEWFOUNDLAND—VIEW OF MILLERTON MILLS, SHOWING LIVE ROLLS CONVEYING LUMBER TO YARD.

size, but it is generally admitted that it is on account of the lightness of the soil, and also the fact that large areas have been burnt over.

The white pine is of superior quality and is the mainstay of the industry. It runs from 12 to 36 inches at the butt up to 40 feet before a limb is reached and then reaches from 10 to 30 feet further. Most of the trees make three saw logs, while fully 10 per cent. are free from knots. The pine belt occupies about 2,000 square miles of territory, and at a low estimate it is figured it contains 3,000,000,000 feet.

Newfoundland fir is considered particularly good, it grows to a good size and is sound. In England the spruce and fir are known as white-wood. In estimating the future of an industry an important factor which has considerable weight with the operator is the accessibility of the region he is operating in to the market, or to speak more concisely, the available means of transportation. In this respect Newfoundland is well served, having 6,000 miles of coast line

with deep bays, inlets and natural harbors, which are adjacent to many of the forest belts, besides possessing many valuable inland waters where rafts and logs can be floated to the mills with the greatest of ease. Chief among these is the Great Rattling River, Exploits, Sandy Lake emptying into the Grand Lake, Gambo River and others, all of which possess a horse power varying from 5,000 to 30,000, while at Millertown at the foot of Red Indian Lake on the Exploits River, is a horse power of 10,000, and further down the river at Grand Falls is the horse power of 30,000. At Bishop Falls, about three miles further down on

the Exploits River, is another power of from 20,000 to 30,000 horse. Again, there is the Reid Newfoundland Railway stretching from St. John to Port-aux-Basque with branches covering 648 miles and an admirable bay at steam service. By these splendid means of transportation all the timber areas can be reached and explored at a minimum of discomfort and cost.

Like all other lumber countries going through a rapid stage of development, Newfoundland has suffered from the old enemies—forest fires and indifference to the rudimentary principles of re-forestry.

To the traveller passing along the line of railroad, the lumber looks particularly forbidding, this being the case all along the line on account of the tremendous fires which have been caused through the carelessness of berry pickers, trouters, sporters, and pleasure seekers. The lumbermen have estimated the loss from fires during the past century as in the neighborhood of \$75,000,000, which it is safe to say with the exercise of ordinary care would to a great extent have been saved. The following are the leading lumber companies now operating on the island, with their output or capacity:

The Newfoundland Timber Estates, Limited, 300,000 feet daily.

Exploits Lumber Company, 85,000 feet daily.

Newland Lumber & Pulp Company, Limited, 100,000 feet daily.

St. Georges Lumber Company, 20,000 feet daily.

Fisher mill, with a capacity of 20,000 feet daily. The Newfoundland Timber Estates, Limited—the largest of these concerns—was incorporated under the laws of Newfoundland on March 21st, 1903, with a capital of \$3,000,000 and the following gentlemen as directors: Harry M. Whitney, Boston, president; Harry J. Crowe, Halifax, vice-president and general manager; W. D. Reid, of the Reid Newfoundland Company, treasurer; B. F. Pearson, Halifax, secretary. Operations are conducted at four different points, Millertown, Glenwood, Gander Bay and Gambo, and they have also a large shipping yard at Lewisport and an office at St. Johns, which is the headquarters of the Company. They own the exclusive right to log or lumber on 1,549,440 acres, or 2,421 square miles of land. A conservative estimate of the timber is 2,440,000,000 superficial feet in the proportion of 40 per cent. pine and the remaining 60 per cent. spruce and fir. Their properties at Glenwood and Millertown were purchased from Lewis Miller.

Millertown is a village twenty miles from Millertown Junction, on the Reid Newfound-



LUMBERING IN NEWFOUNDLAND—MILLS AT GANDER BAY.

land Railroad. It was built by Mr. Miller and includes sixty houses and two large mill—all the Company's property. It has railway connection with the Reid Newfoundland Railway by the Company's branch line twenty miles in length. The mills have each a capacity of 50,000 feet per day. Both are equipped in the most modern manner, with log haul-ups, trimmers, circulars, triple bench sawing machines, slabbers, lath machines, two band saws, Swedish gangs and a perfect roller equipment. There are also excellent yards for piling, into which railroad sidings are run and the lumber shipped to Lewisport, 80 miles away, where the company have a very large piling yard from which the lumber is shipped to the different markets. The village is situated at the foot of Red Indian Lake, which is 34 miles long by one to two broad. A great many of the villagers are immigrants from Sweden, thoroughly conversant with the lumber business through long training both in Sweden and here. They prove themselves thoroughly attached to their work and go into the woods with their families in the fall, remaining there all winter executing contracts with the company.

The property at Glenwood, which is situated

at Glenwood Lake on the Gander River, consists of two mills each with a capacity of 50,000 feet per day. A large quantity of pine is cut in these mills, while the total limits of spruce, pine and fir here amount to 300,000 acres. Splendid shipping facilities are provided by the Reid Newfoundland Railway to Lewisport, 27 miles away.

The Company's mill at Gander Bay, 30 miles from Glenwood, was purchased from the Phillips Estate, the former operators. The limits here cover about 270,000 acres of land on each side of the Gander River and Lake. The latter is over 30 miles long. The mill has recently been equipped with all modern machinery. Its capacity is 75,000 feet daily. The lumber manufactured at this point will be shipped directly to the South American and English markets.

The Gambo operations are on the Gambo River about 40 miles from Lewisport. Here the limits cover 195,000 acres and include a large quantity of pine. The mill is operated by water and is well equipped with machinery, the daily capacity being 50,000 feet. Connected

tity of fine pine. Their shipping port is at Botwoodville. They also own Bishops Falls water power, where there is an excellent site for a pulp and paper mill.

The New Land, Lumber & Pulp Company, incorporated under the laws of Newfoundland, have \$1,000,000 capital stock. The following gentlemen are directors: J. H. Williams, Albany, N. Y., president; Harry J. Crowe, Halifax,



LUMBERING IN NEWFOUNDLAND—MILLS AT NORRIS ARM.

vice-president and general manager; Henry Patton, Albany, N. Y., treasurer; Donald Morrison, ex-judge, St. Johns, Nfld., secretary. The limits consist of 320,000 acres, located in the pine belt of the island. Careful cruisers have estimated this property to have at least 15 cords of pulp wood on an average acre. The Company erected two years ago a large up-to-date mill at Norris Arm, where they can ship their product by water or rail. They have also built up a village at this place for their workmen and another small mill at Indian Arm.

Since the above was written a British syndicate, with a capital of \$5,000,000, is reported



LUMBERING IN NEWFOUNDLAND—RIVER DRIVING AT NORRIS ARM.

with it is a steam planing clapboard mill at which all the lumber intended for the local market from the various mills is planed, as this is the nearest point to St. Johns. A goodly number of schooners carry this lumber to the different local markets.

Lewisport is the shipping point for the output of all the mills except the one at Gander Bay. There is a lumber yard at Lewisport with a storage capacity of forty million feet, two miles of railway siding, offices and sheds. The port is open for navigation from the last of April till the middle of December.

The Company loaded eleven cargoes at this port for South America during the summer of 1904. The quality and manufacture of the lumber is particularly adapted for this market.

Indian Bay is a well wooded block of timber land consisting of 96,000 acres. This property has not yet been operated, the company holding it in reserve while developing their other properties.

The Exploits River Pulp Company is practically owned by Wood, Barker & Company, of Boston, Mass. Their limits consist of about 700,000 acres, on which there is a very large quantity of pulp wood, also a very large quan-

to have acquired several of the properties above described.

NEW TIMBER REGULATIONS.

Because of large quantities of burnt timber on Dominion lands in the Northwest Territories, which it is desirable to remove as it is a menace to the green timber in case of fire running through it, the regulations governing the disposal of timber on Dominion lands are amended by providing that the owners of timber berths may be permitted to obtain this timber upon payment of one-half of the dues provided by the regulations.

THE CANADIAN NATIONAL EXHIBITION.

The Canadian National Exhibition at Toronto this year was without doubt the most successful ever held. Progress was shown in the number and character of the exhibits, while the attendance far exceeded any previous exhibition, which was due in part no doubt to the exceptionally favorable weather.

In the Machinery Hall, an exhibit of special interest to mill men was that of the E. Long Manufacturing Company, of Orillia, Ont. They showed a No. o. saw mill carriage, opening 36 in. from saw, fitted with Knight dogs with over-hand ratchet set works. The knees are receded by coil springs and can be stopped in the required position by a hand brake, while the axle is fitted with self-oiling boxes, requiring a minimum of power to operate. They also showed a section of a No. 1 carriage with steel log seats and steel knees, with 40 in. opening, suitable for a mill of capacity of 25,000 feet per day, a section of a No. 2 carriage for a mill capacity of about 40,000 feet per day, a No. 1 two-saw edger, a No 2 three-saw edger, portable mills, etc.

In the exhibit of the A. R. Williams Machinery Company, Toronto, were to be seen in operation the Eclipse smoothing planer manufactured by Major Harper & Son, of Whitby, Ont., a pyramid of wood-split pulleys, and woodworking machinery and tools from the works of the McGregor-Gourlay Company and the Stevens Company, Galt, Ont., the Springfield Machine Tool Company, Springfield, Ohio, and Manning, Maxwell & Moore, New York and Chicago.

William R. Perrin & Company, Toronto, exhibited filter presses, hydraulic screw presses, detachable chain belt and conveying machinery.

Besides gas and gasoline engines, the Canadian Fairbanks Company exhibited wood split pulleys, belting, steam and power pumps, valves, scales and woodworking machines manufactured by the American Woodworking Machinery Company, for which they are Canadian agents.

The exhibitors of belting and mill supplies were the Dominion Belting Company, Hamilton, and D. K. McLaren, Montreal, the former showing their "Maple Leaf" brand of cotton duck belting and the latter their well-known oak tanned leather belting.

A very complete range of power transmission appliances was shown by the Dodge Manufacturing Company, Toronto, including wood split pulleys in operation, couplings, hangers, self-oiling bearings and the Dodge car puller, which has a capacity of from five to eight cars.

The Garlock Packing Company, of Hamilton, Ont., had a very creditable exhibit of Garlock packings, asbestos and mineral wool pipe and boiler coverings and other well-known lines.

The Canada Metal Company, Toronto, had a splendid display of babbitt and solder metals, copper, pig lead, etc.

J. N. Tallman & Sons, Hamilton, showed a general line of "Arctic" anti-friction babbitt metal, ingot copper, pig-lead, antimony, and machinery and ornamental brass, as well as

Tallman's white bearing metal, which they are just placing on the market.

The Canada Foundry Company again occupied a large space, the display including a Canada water tube boiler, an Underwriter's fire pump, 20 x 12 x 16, of a capacity of 1,500 gallons per minute, Northey pumps, "Easy" injectors, hydrants, valves, architectural iron work, etc.

An exhibit which attracted considerable attention was that of S.E. Bowser & Company, Fort Wayne, Ind., patentees of the Bowser system of oil storage. This is regarded as the up-to-date method for the handling and storing of oils and other non-lubricants, the self-measuring oil tanks being very convenient. The system can be adopted to all conditions and for all kinds of oil. Their special "factory" oil cabinet is very suitable for saw mills and woodworking factories, but a more complete system for a separate oil house can be furnished whereby the tanks are placed in the oil house and the bunks at a distance in the factory. Mr. J. B. Bate, 530 Front street west, is their Toronto representative.

"Paroid" roofing as manufactured by F. W. Bird & Son, Hamilton, was shown by the Eureka Mineral Wool Company, their Toronto representatives.

The Gilmour Door Company, of Trenton, Ont., had an exhibit in the Transportation Building. A complete line of handsome veneered doors in rare and highly finished woods was shown. In the Manufacturers' Building were to be seen attractive displays of the goods manufactured by the Gutta Percha & Rubber Manufacturing Company, Toronto; Durham Rubber Company, Bowmanville, Ont.; Berlin Rubber Company, Berlin, Ont.; and the Canadian Oil Company, Toronto. The Waterous Company, Brantford, Ont., exhibited a gasoline fire engine, and the Georgian Bay Engine Works, Midland, two gasoline engines.

UNITED STATES LUMBERMEN ENTER-TAINED AT SARNIA.

Sixteen lumber dealers from the states of Pennsylvania, Ohio and New York accepted the invitation of the Cleveland-Sarnia Saw Mills Company, of Sarnia, Ont., to be their guests on September 2nd. They were received by Mr. J. M. Diver, general manager of the company, and Mr. Fred W. Shaw, salesman, and escorted to the Hotel Vendome, where they took dinner. In the afternoon they were shown through the extensive plant of the company. They were taken for a trip up the lake on one of the tugs of the Reid Wrecking Company to view one of the company's large raft of logs at anchor about sixty miles up Lake Huron. On Monday the party were taken to Kettle Point on a fishing trip, returning to Sarnia in the evening and taking the steamer for Detroit.

The delegation was composed of the following gentlemen: L. D. Comau, Cleveland Lumber Co., Cleveland; J. H. Shaw, Wallace & Carley Lumber Company, Sharon, Pa.; J. R. Wishart, of A. Wishart & Sons, Sharon, Pa.; Chas. Loveless, Warren Mfg. Co., Warren, Ohio; Chas. Wood, Western Reserve

Lumber Co., Warren, Ohio; Louis Heller, of Heller Bros. Lumber Co., Youngstown, Ohio; A. Bruckman, of Bruckman Lumber Co., Alleghany, Pa.; Jas. D. Johnston, of the Jas. D. Johnston Lumber Co., Erie, Pa.; Geo. Carroll, of Geo. Carroll & Bro., Erie, Pa.; F. A. Brown, Brown Lumber Co., Massillon, Ohio; Chas. Ducotey, of Tollerton & Son, Alliance, Ohio; S. L. Malin, of Malin & Sons, Plainsville, Ohio; C. C. Jenkins, of C. C. Jenkins Lumber Co., Willoughby, Ohio; S. E. Putnam and H. Savage, of Putnam & Savage, sales agents for Cleveland-Sarnia Saw Mills Co., Cleveland, Ohio.

RAISING SUNKEN LOGS.

The beds of rivers where lumbering operations have been carried on for years are known to contain many sunken logs, and more attention is being given each year to the utility of raising them. A gentleman who has given the question much study and has formulated certain plans which he believes can be successfully carried out, is desirous of learning where logs have been sunk, particularly in rivers or streams on which lumbering has ceased. The editor of this journal will be glad to hear from anyone interested in the subject.

A HANDY LUMBER SCALE.

The accompanying "ready reference lumber scale" will be found convenient for any one needing its use. Nearly all of the ordinary dimensions of box lumber will be found contained in this first instalment:

READY REFERENCE LUMBER SCALE.
Lengths, feet.

Size inches.	10	12	14	16	18	20	22	24	26
1 x 2	1 1/2	2	2 1/2	3	3 1/2	4	4 1/2	5	5 1/2
1 x 3	2 1/2	3	3 1/2	4	4 1/2	5	5 1/2	6	6 1/2
1 x 4	3 1/2	4	4 1/2	5 1/2	6	6 1/2	7 1/2	8	8 1/2
1 x 5	4 1/2	5	5 1/2	6 1/2	7 1/2	8 1/2	9 1/2	10	10 1/2
1 x 6	5	6	6 1/2	7 1/2	8 1/2	9 1/2	10 1/2	11	11 1/2
1 x 7	5 1/2	6 1/2	7 1/2	8 1/2	9 1/2	10 1/2	11 1/2	12 1/2	13
1 x 8	6 1/2	7 1/2	8 1/2	9 1/2	10 1/2	11 1/2	12 1/2	13 1/2	14 1/2
1 x 9	7 1/2	8 1/2	9 1/2	10 1/2	11 1/2	12 1/2	13 1/2	14 1/2	15 1/2
1 x 10	8 1/2	9 1/2	10 1/2	11 1/2	12 1/2	13 1/2	14 1/2	15 1/2	16 1/2
1 x 11	9 1/2	10 1/2	11 1/2	12 1/2	13 1/2	14 1/2	15 1/2	16 1/2	17 1/2
1 x 12	10	11	12	13	14	15	16	17	18
1 x 13	10 1/2	11 1/2	12 1/2	13 1/2	14 1/2	15 1/2	16 1/2	17 1/2	18 1/2
1 x 14	11 1/2	12 1/2	13 1/2	14 1/2	15 1/2	16 1/2	17 1/2	18 1/2	19 1/2
1 x 15	12 1/2	13 1/2	14 1/2	15 1/2	16 1/2	17 1/2	18 1/2	19 1/2	20 1/2
1 x 16	13 1/2	14 1/2	15 1/2	16 1/2	17 1/2	18 1/2	19 1/2	20 1/2	21 1/2
1 x 17	14 1/2	15 1/2	16 1/2	17 1/2	18 1/2	19 1/2	20 1/2	21 1/2	22 1/2
1 x 18	15	16	17	18	19	20	21	22	23
1 x 19	15 1/2	16 1/2	17 1/2	18 1/2	19 1/2	20 1/2	21 1/2	22 1/2	23 1/2
1 x 20	16 1/2	17 1/2	18 1/2	19 1/2	20 1/2	21 1/2	22 1/2	23 1/2	24 1/2
1 1/2 x 4	4 1/2	5	5 1/2	6 1/2	7 1/2	8 1/2	9 1/2	10 1/2	11 1/2
1 1/2 x 6	6 1/2	7 1/2	8 1/2	9 1/2	10 1/2	11 1/2	12 1/2	13 1/2	14 1/2
1 1/2 x 8	8 1/2	9 1/2	10 1/2	11 1/2	12 1/2	13 1/2	14 1/2	15 1/2	16 1/2
1 1/2 x 10	10 1/2	11 1/2	12 1/2	13 1/2	14 1/2	15 1/2	16 1/2	17 1/2	18 1/2
1 1/2 x 12	12 1/2	13 1/2	14 1/2	15 1/2	16 1/2	17 1/2	18 1/2	19 1/2	20 1/2
1 1/2 x 4	5	6	7	8	9	10	11	12	13
1 1/2 x 6	7 1/2	8 1/2	9 1/2	10 1/2	11 1/2	12 1/2	13 1/2	14 1/2	15 1/2
1 1/2 x 8	9 1/2	10 1/2	11 1/2	12 1/2	13 1/2	14 1/2	15 1/2	16 1/2	17 1/2
1 1/2 x 10	11 1/2	12 1/2	13 1/2	14 1/2	15 1/2	16 1/2	17 1/2	18 1/2	19 1/2
1 1/2 x 12	13 1/2	14 1/2	15 1/2	16 1/2	17 1/2	18 1/2	19 1/2	20 1/2	21 1/2
1 1/2 x 14	15 1/2	16 1/2	17 1/2	18 1/2	19 1/2	20 1/2	21 1/2	22 1/2	23 1/2
1 1/2 x 16	17 1/2	18 1/2	19 1/2	20 1/2	21 1/2	22 1/2	23 1/2	24 1/2	25 1/2
1 1/2 x 18	19 1/2	20 1/2	21 1/2	22 1/2	23 1/2	24 1/2	25 1/2	26 1/2	27 1/2
1 1/2 x 20	21 1/2	22 1/2	23 1/2	24 1/2	25 1/2	26 1/2	27 1/2	28 1/2	29 1/2
2 x 3	5	6	7	8	9	10	11	12	13
2 x 4	6 1/2	8	9 1/2	10 1/2	11 1/2	12 1/2	13 1/2	14 1/2	15 1/2
2 x 5	8 1/2	10	11 1/2	12 1/2	13 1/2	14 1/2	15 1/2	16 1/2	17 1/2
2 x 6	10	12	14	16	18	20	22	24	26
2 x 7	11 1/2	14	16 1/2	18 1/2	21	23 1/2	25 1/2	28	30 1/2
2 x 8	13 1/2	16	18 1/2	21 1/2	24	26 1/2	29 1/2	32	34 1/2
2 x 9	15	18	21	24	27	30	33	36	39
2 x 10	16 1/2	20	23 1/2	26 1/2	30	33 1/2	36 1/2	40	43 1/2
2 x 11	18 1/2	22	25 1/2	29 1/2	33	36 1/2	40 1/2	44	47 1/2
2 x 12	20	24	28	32	36	40	44	48	52
2 x 14	23 1/2	28	32 1/2	37 1/2	42	46 1/2	51 1/2	56	60 1/2
2 x 16	26 1/2	32	37 1/2	42 1/2	48	53 1/2	58 1/2	64	69 1/2
2 x 18	30	36	42	48	54	60	66	72	78

—From Packages, Milwaukee.

Copp, Dixon & Company have decided to rebuild their woodworking factory at Sackville, N.B.

The Elk Lumber & Manufacturing Company, whose mill at Fernie, B.C., was destroyed by fire last month, will at once erect a temporary mill on the old site to saw their timber tributary to Fernie. Later, probably next fall, they will build a large mill at Hosmer, which is a more advantageous site on account of being nearer to the limits.

CORRESPONDENCE

ARE FORESTS DAMAGED BY LUMBERING OPERATIONS?

Translated from the Russian LESOPROMISHLENY VIESTNIK (timber exporters' news).

In whitewood forests, Government as well as private owned, the method of felling now in vogue is generally partial, i. e., of selected dimensions only. In the Government forests the buyers take the larger sizes, from six vershoks and thicker (10½ inch tops diameter), and in those belonging to private individuals from four vershoks and up (7 inch tops). On examining the felled areas in after years in both the above categories of forest, we came to the conclusion that there was an exceedingly large quantity of dry standing timber. After considerable study we decided that in Government forests, where the thicker sizes only were felled, the quantity of dry wood equalled that of the quantity taken out, and consisted more particularly of matured timber, while in forests belonging to private owners where thinner dimensions were cut down (7 inch diameter tops), the quantity of dry timber was very great indeed. We are inclined to attribute such a considerable deterioration of timber to the thinning of forests by felling the merchantable trees to such an extent that the remainder are swayed by the wind, and through the continued rocking movement the smaller fibres of the root break in the ground, the consequence of which is that the tree receives insufficient nourishment. After that its complete destruction is but a matter of time.

It is evident from the above that the system of felling timber as practised at present is faulty in the extreme, and should be discarded for a more perfect one, and one by which such a considerable proportion of standing timber would not be spoiled. The felling of picked dimensions is only possible in cases where wood is of no great value. Now that forests have become exceedingly valuable property, it is necessary that the Department of Forestry should work out a scheme which would not only give the greatest possible return, but would, at the same time, not cause the property itself to deteriorate in value. It can scarcely be termed satisfactory business when, after felling a certain number of trees, an almost equal quantity is irreparably damaged, all through our lack of knowledge of forestry. In view of this it becomes a matter of vital importance to determine the maximum number of trees which it is permissible to fell, without causing harm to the remainder. Various trials in whitewood forests should be made, for besides the dead loss of the dry wood, the whole property deteriorates, for these trees attract numerous harmful insects, the wood falls in time, choking up the forest, and the wind, with greater scope than ever, completes the work of devastation. Obstructions in forests such as are caused by fallen trees are conducive to fires, the harm of which it is unnecessary to dilate upon. Trials should be undertaken for a number of years in one centre. We consider that these should be carried out in Government forests by placing aside trial areas and determining in that way the maximum number of trees which it is feasible to fell simultaneously, without harming the remaining timber.

DR. CLARK'S OPINION.

As it has been claimed that similar conditions exist in Canada, the above article was submitted by the editor of the CANADA LUMBERMAN to Dr. Clark, Provincial Forester for Ontario, who kindly replied as follows:

TORONTO, AUGUST 28TH, 1905.

Editor CANADA LUMBERMAN:

DEAR SIR,—I have not seen these forests in Quebec and New Brunswick which, it is said, are being "absolutely ruined" by cutting selected dimensions. I have examined a large tract of spruce in New Hampshire which has been cut to a diameter limit of 12 inches for 25 years, and was in no way harmed by the process. Of course a diameter limit of 12 inches is high and the

cutting could not be regarded as an excessive thinning.

Excessive thinning of some kinds of trees would have much the effect described as occurring in Russia. The injury is, however, far from being wholly caused by injury to the root systems of the trees due to the swaying. It is in part at least due to the unfavorable moisture conditions brought about by the access of sun and wind to the soil, and not infrequently increased by "sun scald" and windfall.

The question as to what can be done to improve conditions as regards felling in Canada is a very large one, indeed. What is suited for one species is often not at all suited for others. Locality has also much to do with it, for what would be good practice on a spruce flat might be ruinous on a steep, wind-swept slope. As a rule a personal examination by a competent forester would be necessary to determine what under given conditions would be the wisest policy.

Viewed from the standpoint of future production, the greatest defects in present logging methods are (1) the absence of seed trees of valuable species on logged areas and the presence of seed trees of the inferior species which, in the absence of their more valuable neighbors, presently succeed in monopolizing the soil with their inferior progeny, and (2) the inflammable condition of the logging debris which all too often results in forest fires which practically destroy all hope of natural recovery for a generation.

Experiments in cleaning up the debris on logged areas on Minnesota pineries are most encouraging. It has been found by the lumbermen who bought the government stumpage on condition that the debris be cleaned up, that the cost of burning the brush as the logging proceeded was at most 25 cents per M feet cut, and where the stand was heavy, was as low as 15 cents per M. This would indicate that where stumpage values are at all considerable the state or province can well afford to take a little less money and have reasonable security from fire, and with a reservation of seed trees, good prospect of another crop of pine. It should be added that a second condition of the sale was that 5 per cent. of the trees (to be marked by trained foresters) were to be left for seed purposes. Some of these trees will doubtless blow down, and others may eventually die. There is, however, no doubt but that the forest will be regenerated and that the next crop will be white pine, and there is little danger from fire. The only experimental part was as to the practicability of burning the brush at moderate cost under American conditions. The effect of the absence of debris and the presence of seed trees has, of course, been known for a century.

Yours very truly,

JUDSON F. CLARK,

Provincial Forester.

PRESERVATION OF YOUNG PINE.

PEMBROKE, September 21st, 1905.

Editor CANADA LUMBERMAN:

DEAR SIR,—I notice a communication in this month's issue of the CANADA LUMBERMAN from E. Stewart, Superintendent of Dominion Forestry, asking whether it is more profitable for lumbermen to cut the young and immature pine or wait for its further development in growth. Speaking from a long experience and being familiar with all the conditions of the lumbering operations in the Ottawa and Nipissing districts, I have no hesitation in saying there is no profit in cutting young pine trees under 12 inches diameter on the stump. This practice has only been followed by Ottawa lumbermen for the past few years. Since the Ottawa Improvement Company have changed their system of collecting tolls by the piece to the thousand feet B. M., more small pine has been cut. Those small sapling saw logs are not only unprofitable to handle, but over 20 per cent. of them never reach the

mill. Whenever the water gets warm they get soggy and go to the bottom of the river.

The Crown Lands Department of Ontario should adopt the same regulations as the Province of Quebec, restricting the cutting of pine for saw logs to not less than 12 inches diameter on the stump, especially in localities where it is not exposed to forest fires from railways or settlers clearing land, and by instructing their forest rangers to see these regulations enforced, it would in a measure stop the unprofitable destruction of young pine. I would also suggest that the Government should insist on licensees placing sufficient fire rangers on all their limits to properly guard them during the summer months. There are large areas of cut and burned-over limits in the Ottawa district still held under license but not operated upon for some years, and no fire rangers in the territory. Those areas are now grown over with young red and white pine from 25 to 30 feet high and over sixty inches in diameter, sheltered by white birch and poplar that has caused this young pine to grow long and the trunks free from limbs and knots. They have a good start to produce valuable lumber in a few years and if protected will soon largely displace the other woods. In a short period of time this worthless country (and it is perfectly worthless for agricultural purposes) through the natural growth of this young pine, would be worth from \$10 to \$15 per acre; and not only for the value of the timber but for the climatic reasons also every precaution should be taken to guard it from forest fires.

Yours truly,

FORESTER.

LUMBER INSURANCE.

Sept. 20, 1905.

Editor CANADA LUMBERMAN:

DEAR SIR,—Your columns in the September number devoted to lumber insurance have been read with interest. The same question has been paramount with lumbermen in the United States for some time, agitated by a similar unjust system of raising rates on the part of the board companies, making the lumber trade pay higher premiums to retrieve the heavy losses experienced in other classes of business.

To offset this tendency on the part of the "old line" companies to make a good thing out of their lumber lines and their too evident and willing blindness to a fair discrimination in risks, stock and mutual fire insurance companies, limiting their risks strictly to the lumber trade, have been organized and operated with what success every lumberman knows.

For Canadian lumbermen to follow the same step is possible, though presenting a great outlay of time and expense. Lumbermen are not prepared off-hand to enter the insurance field without a careful study of the ins and outs of this complicated business, or the aid of experienced insurance men. The former means delay when prompt action is needed; the latter necessitates putting the organization out of the complete control of the lumbermen themselves.

Returning to the companies operating in the States, it is a well-known fact that they have won an excellent reputation for their prompt settlement of losses. Though not backed with heavy capital nor surplus, as compared with the "old line" companies, they are, in a sense, compelled to meet their obligations fairly. Dependent as they are upon the good-will of the lumber trade for their success, it is easily a fact that as soon as they prove unsafe or inclined to act otherwise than squarely, the lumber associations will make it too hot for them to continue their business.

Under the circumstances, and in consideration of the great saving involved in the cost of insurance, it should not be out of place for Canadian lumbermen to take advantage of these facilities to a large extent. There is one combination of these companies that is offering to place \$50,000 insurance on a single yard at rates not more than 80 per cent. of the charge of the board companies. Though this amount in some instances may seem like a mere drop in the bucket, would it not have some effect? Insurance companies are not so willing to see their profitable business turned to outside channels that they will not endeavor to meet the competition.

If the cost of \$50,000 insurance on a yard can be greatly reduced by placing it in outside companies, the

chances are that the board companies, through fear of losing still more of their business, will discover some new feature in the risk by which the rest of the insurance, in their opinion, will seem to merit a lower rate. Is it not an experiment worth trying?

The objection has been raised that these companies are not formally licensed under the laws of the Dominion. Setting aside the probability that they would doubtless register in Canada if given sufficient encouragement by lumbermen to do so, there are a few points which on consideration seem to make this not absolutely necessary.

The rapidly-growing recognition of the community of interest between the lumbermen of Canada and the United States, and the extensive field in their particular line open to these companies through the development of Canadian timber lands, should act as a strong incentive to them to treat as they hope to be treated. This is practically the same influence that the extensive development of lumber associations has had in the States.

Responsible to some State department as every one of them is, their records open to any who ask, their books examined by authorized inspectors, it remains for the policy holder to judge whether he can put his trust in them. Knowing their reputation and the circumstances under which they have been organized and operated, the question of safety becomes a minor consideration.

Yours truly,

"SUBSCRIBER."

PROPOSED AMENDMENTS TO TIMBER REGULATIONS.

TORONTO, September 10th, 1905.

Editor CANADA LUMBERMAN:

The Minister of Lands and Mines of Ontario has promised to consider any amendments to the Statutes affecting the lumber trade with a view of simplifying them. It is proposed to lay before him amendments so that they can go into effect next session.

In the meantime the views of practical lumbermen are wanted as to some of the difficulties at present existing and any communication from them will be carefully considered.

At present, amendments to the Rivers and Streams Act are being prepared. They are set out below. Under that Statute compensation is given if river improvements are used. But they must be tolls and the Courts say they must be fixed as tolls before the using, otherwise compensation is uncollectable. Again, one County Judge has decided that if a stream is once made floatable, no matter how long ago, all subsequent improvements are free. Another holds that the whole history of the river must be followed up and that cost of original improvements, even twenty years old, must be considered each time in fixing tolls, while a third Judge considers that only repairs and new improvements can be considered, although the old ones have cost money and are in good repair.

The following simple amendments are proposed.

1. Present Statute—(Sec. 11).

"But all persons shall have during the spring, summer and autumn freshets, the right to float and transmit saw-logs and other timber, rafts and crafts, down such rivers, creeks or streams and through and over the constructions and improvements, doing no unnecessary damage to the constructions and improvements, or to the banks of the said rivers, creeks or streams, subject to the payment to the person who has made the constructions and improvements of reasonable tolls."

Proposed Statute. Add to above the words

"which may be fixed as hereinafter mentioned either before or after the same have been used and may be so fixed either as to (1) the whole or any portion of such improvements, or (2) of the river, stream or creek affected thereby, or (3) may be limited to the annual repairs and new improvements made thereon."

2. Present Statute—(Sec. 13).

"And the Judge or Stipendiary Magistrate in fixing the tolls shall have regard to and take into consideration the original cost of the constructions and improvements, the amount required to maintain the

same and to cover interest upon the original cost, as well as such other matters as under all the circumstances may seem just and equitable."

Proposed Statute (insert words in italics).

"And the Judge or Stipendiary Magistrate in fixing the tolls shall have regard to and take into consideration the original cost of the construction and improvements to such extent as the same or any part thereof shall seem to him to be material in fixing the tolls upon such application, the amount required to maintain the same or the amount spent in repairs or new improvements and to cover interest upon the original cost or upon the cost involved in such application, as well as such other matters as under all the circumstances may seem just and equitable."

3. PRESENT STATUTE—(Sec. 11).

"In case any person shall construct in or upon such river, creek or stream, an apron, dam, slide, gate, lock, boom, or other work necessary to facilitate the floating or transmission of saw logs or other timber, rafts or crafts down such river, creek or stream, which was not navigable or floatable before the improvements were made, or shall blast rocks or remove shoals or other impediments, or otherwise improve the floatability of the river, creek or stream, such persons shall not have the exclusive right to the use of the river, creek, or stream or to the constructions and improvements."

Proposed Statute (add words in italics, making it read as follows):—

"In case any person shall construct in or upon such river, creek or stream, an apron, dam, slide, gate, lock, boom or other work necessary to facilitate the floating or transmission of saw logs or other timber, rafts or crafts down such river, creek or stream which was not navigable or floatable before the improvements were made or which has been made more easily navigable or floatable by any such improvements, or shall blast rocks or remove shoals or other impediments, or otherwise improve the floatability of the river, creek or stream, such person shall not have the exclusive right to the use of the river, creek or stream, or to the constructions and improvements."

The result of these changes is to (1) make compensation easily computed and to be fixed either before or after using, and (2) to enable compensation to be fixed either for total cost from the beginning or for a limited time or section as the parties may agree.

Any communications addressed to the undersigned or to this paper will be dealt with and laid before the Minister. It is intended to deal with the Timber licenses, Free Grant Acts, and Saw Log Driving Act in later letters.

Yours truly,

FRANK E. HODGINS,

(Of McMurrich, Hodgins & McMurrich, 103 Bay Street, Toronto.)

PREVENTION OF SAP STAIN IN LUMBER.

The Lumber Anti-Stain Company, of Bay Mills, Mich., have forwarded to us a copy of a letter which they have sent to the Timber News and which we reproduce below:

BAY MILLS, MICH., Sept. 8, 1905.

The Timber News,
84 Leadenhall St.,
London, E. C., Eng.

GENTLEMEN,—We have your esteemed favor of the 12th ultimo and beg to thank you for the issue of the Timber News of same date, received by us from you in the same mail. We note your article on "Sap Stain in Lumber" with reference to us and our process, all of which appears to be copied mainly from the CANADA LUMBERMAN.

The original in the CANADA LUMBERMAN was duly called to our attention. We did not intend to reply to it inasmuch as the erroneous portion of their statements is so manifestly a mistake that it would convey no effect of importance upon lumbermen who know anything about our process.

Nevertheless, since the article was being reprinted in other journals, we concluded to write to the CANADA LUMBERMAN calling attention to the erroneous portion of the article, and also to their erroneous conclusion,

which mistaken conclusion we see you have reprinted in your wording, namely, "They do not record a really good and profitable solution of what has always been and looks likely to remain, a difficult problem."

The article in the CANADA LUMBERMAN is substantially accurate except as to the following sentence which we quote: "But taking into consideration the royalty and the expense of doing the work, it is not generally considered advantageous."

We will remark first that this article is absolutely correct in stating that our process is "very simple," "quite successful" and that "any sap in the lumber, whether on edge or across the face of the board, is thus prevented from staining, and the lumber comes out white and bright."

Passing on to the erroneous statement of the article we have to say: When used on a limited scale, the lumber in this process is treated by hand at a cost for labor of 15 cents per thousand feet. Where handled on a large scale, by an inexpensive addition to the machinery equipment of the saw-mill, the treating is done automatically, doing away with labor cost entirely. This automatic treatment can be seen in operation in connection with our process to-day in the United States; and there will be much more of the mechanical treatment in evidence in the early future in connection with our process.

It is a commonly known fact that the depreciation in value of lumber from the sole reason of sap-staining will run as high as \$30.00 per thousand feet, or even more. The range of loss may be said to be, very conservatively speaking, from \$3.00 to \$30.00 per thousand feet.

Inasmuch as the Lumber Anti-Stain Company charges for royalty a nominal sum which is a mere fraction of the amount of saving effected by use of its process, and the labor and cost of material and apparatus is so inconsiderable that it can be almost ignored, we submit the statement referred to and the conclusion drawn by the CANADA LUMBERMAN and your esteemed selves, is not fair to us, and might work serious disadvantage to lumbermen who are not acquainted with the expense and results of our process.

We appreciate your courtesy in calling our attention to your article. We hope we have expressed ourselves in this communication in an agreeable and considerate tone.

We take the liberty of enclosing a copy of one of our pamphlets containing some of the testimonials we have received regarding our process.

Yours truly,

THE LUMBER ANTI-STAIN CO.

R. H. Munson, Pres.

PUBLICATIONS.

English Bros., Limited, Wisbech and Peterborough, England, have issued a new booklet designed chiefly to explain their system of creosoting timber.

"Terms Used in Forestry and Logging" is the title of Bulletin No. 61, which is about to be issued by the Forestry Division of the United States Department of Agriculture, Washington, D. C. The bulletin will include two separate lists of terms, the first comprising the technical vocabulary of American forestry, the second the terms in common use among lumbermen.

The second edition of "Tangible Results" has been issued by the Waterous Engine Works Company, Brantford, Ont. By means of several diagrams, the advantages and economy of the band saw over the circular saw are shown. The catalogue also contains illustrations and descriptions of several Waterous machines, including saw carriages, ratchet networks, timber dial, mill dogs, gunshot steam feed, trimmers, pulp-wood barkers, etc.

William Rider & Son, Limited, proprietors of the "Timber Trades Journal," London, England, have just published "Suwyn's Register of Timber Carrying Steamships." This is the first work that has appeared giving authentic particulars concerning the vessels engaged in the Baltic and White Sea timber trade, and it is anticipated that the valuable information it contains will prove of great convenience to chartering agents, ship brokers, timber importers, etc. It is intended to publish new editions periodically so as to keep the Register up-to-date.

THE Canada Lumberman

AND WOOD-WORKER

(Monthly and Weekly Editions—One Dollar Per Year.)

PUBLISHED BY

The C. H. Mortimer Publishing Company
of Toronto, Limited,

CONFEDERATION LIFE BUILDING, TORONTO.

BRANCH OFFICES:

38 ALLIANCE BUILDING, MONTREAL.

720-721 UNION BANK BUILDING, WINNIPEG.

Telephone 1274

22 GREAT ST. HELENS, LONDON, E. C.

536 HASTINGS STREET, SUITE 3, VANCOUVER, B. C.

Telephone 1943

The LUMBERMAN Weekly Edition is published every Wednesday,
and the Monthly Edition on the 1st day of every month.

TERMS OF SUBSCRIPTION:

One Copy, Weekly and Monthly, One year, in advance, \$1.00
One Copy, Weekly and Monthly, Six Months, in advance, 50
Foreign Subscription, \$2.00 a Year

ADVERTISING RATES ON APPLICATION.

THE CANADA LUMBERMAN AND WOOD-WORKER is published in the interest of and reaches regularly persons engaged in every part of Canada in the lumber, wood-working and allied industries. It aims at giving full and timely information on all subjects touching these interests, and invites free discussion by its readers.

Special care is taken to secure for publication in the WEEKLY LUMBERMAN the latest and most trustworthy market quotations throughout the world, so as to afford to the trade at home and abroad information on which it can rely in its operations.

Advertisers will receive careful attention and liberal treatment. For manufacturing and supply firms wishing to bring their goods to the attention of owners and operators of saw and planing mills, wood-working factories, pulp mills, etc., the CANADA LUMBERMAN AND WOOD-WORKER is undoubtedly the most direct and profitable advertising medium. Special attention is directed to "WANTED" and "FOR SALE" advertisements, which are inserted in a conspicuous position on front page of the Weekly Edition.

EXPORT CONSIGNMENTS OF LUMBER.

The number and geographical position of the countries contributing to the lumber supply of Great Britain has resulted in the growth of the consignment custom to the point where it has become a menace to the trade, affecting alike exporters and importers. The onus of this condition rests no more upon the shipper than upon the consignee, in fact, we are inclined to place the burden of responsibility largely upon the latter.

Referring particularly to American shipments to Great Britain, it will be admitted that manufacturers and exporters are constantly on the lookout for a market for their product, and are prepared to sell wherever they can secure a reasonable price. Unscrupulous brokers have scattered broadcast circulars inviting consignments of stock, usually enlarging upon the bright prospects for disposing of the lumber at a good margin of profit and agreeing to accept what seems but a just commission. Shipments made in this manner from a number of mills produce a glut on the market, and it is not difficult to imagine the result. Sales are impossible at anything but ruinous prices to the shipper. Furthermore, instances are on record where a clique of foreign buyers have established among themselves fixed prices as the maximum bids for certain consignments. If these bids are not accepted, and the broker is instructed to store the stock, it is but a short time before the charges, such as storage, insurance, etc., become very heavy, and represent a considerable percentage of the value of the lumber. The storing of the lumber also lessens the prospect of a sale, as newly-landed stock, easily accessible for inspection, is preferred. It is claimed that in London the landing and other expenses on consignments are simply enormous, even though they be met with a ready buyer.

American shippers are strongly recom-

mended to ship stock only on firm contracts at a stipulated price. Even the acceptance of offers of a certain advance against bill of lading can scarcely be considered in the interest of the trade, as the results too often prove disastrous.

There are many Canadian shippers who are willing and anxious to do business with Great Britain, but the stock must be inspected and accepted on this side and a guarantee given as to payment. The failure of many firms to do this is responsible for the difficulty they have experienced in forming a reliable trade connection in this country. A manufacturer may make one or two shipments, but if confronted with unusual and exorbitant charges his business cannot be retained.

PROSPERITY AND RAILWAY CONSTRUCTION.

It is doubtful if ever before in the history of Canada there were so many unmistakable evidences of prosperity—prosperity national in character, extending from the Atlantic to the Pacific. Labor is employed to the fullest extent, manufacturers are working to the limit and are largely sold in advance of production, the farmers are marketing abundant crops, and the building industry is very prosperous. A record of building operations this year exceeding nine million dollars in Winnipeg and six million dollars in Toronto but reflects the conditions which prevail almost everywhere. So great has been the demand for lumber for construction purposes that the mills have accumulated very little stock during the sawing season, which is evidence that the time is yet a long way distant when the building requirement will cease to be a large factor in the lumber market.

The immense crop of wheat in the Northwest is the greatest blessing that could be bestowed on that country. A conservative estimate places the yield at over eighty million bushels, (not to speak of a large oat crop), which, if marketed at seventy cents per bushel, represents a monetary return to the farmers of \$56,000,000. These figures are likely to be exceeded, but they are sufficiently near the mark to indicate the magnitude of the western wheat fields and consequent buying power of the farming community.

Another important factor contributing to the prosperity of the country is the construction of a second transcontinental railway, for which ground was broken last month. This national event is one in which lumbermen and owners of timber limits have a special interest. The building of the road will call for unlimited quantities of ties, bridge timbers and other kinds of railway material. Fortunately, the supply is abundant and Canadian contractors will reap the full benefit. Sir Wilfrid Laurier, who has unbounded faith in the future of the Dominion, has predicted that scarcely would the last spike of this road be driven when it would be found necessary to construct another ocean to ocean line.

But railway building in the west is not confined to the Grand Trunk Pacific. Other roads are extending very rapidly, the C.P.R., for instance, having recently awarded the contract

for over two hundred miles, all of which will contribute towards the general prosperity of the people.

PROVINCIAL LICENSING OF TRAVELLERS.

To the provinces of Quebec and British Columbia belongs the credit of having enacted the most ridiculous, selfish and annoying law which has yet been placed upon the statute books. This law imposes a tax on commercial travellers who enter these provinces from foreign countries and from the other provinces of Canada for the purpose of selling goods. For the benefit of any of our readers who are not familiar with this legislation, we print below the main sections of the two acts:

QUEBEC LICENSE LAW.

Any person not residing in the province who is desirous of acting as a commercial traveller, by soliciting or taking orders for or selling goods, wares or merchandise, other than intoxicating liquors, or by advertising or offering such goods for sale, by sample, catalogue or price list, for a person, firm or corporation having no place of business in Canada, shall first obtain a license therefor from the collector of provincial revenue for the district in which he begins his operations in the province. Such license is, subject to article 9 of this act, granted for one year, and expires on the first day of the month of May subsequent to its issue.

For each license for a person not residing in the province to act as a commercial traveller by soliciting or taking orders for, or selling goods, wares or merchandise, other than intoxicating liquors, or by advertising or offering such goods for sale, by sample, catalogue or price list, for a person, firm or corporation having no place of business in Canada, three hundred dollars.

BRITISH COLUMBIA LAW.

No commercial traveller, agent or other person, not being a resident of British Columbia, shall take or solicit orders, either for himself or any other person, for any goods, wares, merchandise, or other effects to be imported into this Province to fill such orders, unless and until he shall have taken out and had granted to him, for the period specified in the Schedule A hereto, a license under this Act, and paid therefor the license fee prescribed in said Schedule A in respect of the class of goods dealt with.

SCHEDULE A.

(a.) By every commercial traveller, agent, or other person taking or soliciting orders for liquor or cigars, or both, to be imported into the province to fill such orders. License fee, \$100 for every six months.

(b.) By every commercial traveller, agent, or other person taking or soliciting orders for goods, wares, merchandise, or other effects of any kind whatsoever (other than liquor or cigars), to be imported into the province to fill such orders. License fee, \$50 for every six months.

The above laws differ in one respect only. The Quebec legislators actually give a bounty for the sale within the province of intoxicating liquors, this being the only business which is exempt from taxation, whereas the British Columbia law discriminates only against the liquor trade. Just why one single business should be given special legislation is not very clear, and it is equally difficult to find any good reason whatever for the existence of the law as a whole.

Of what benefit can such a license be? It is

fair to assume that the system of averages will apply, and if the policy were universally adopted, each province would receive from the other provinces just as much revenue as would be collected from its residents when selling goods elsewhere in Canada. What has British Columbia to gain by such a license? Take the lumber business as an illustration. British Columbia lumber and shingles are sold in almost every province of the Dominion. With the two new provinces in the Northwest, this means that eight licenses would be necessary in order to cover the field, and the expense would be \$800 at the British Columbia rate and \$2,400 at the Quebec rate. As this would be an outlay for which no direct value would be received, many of the smaller firms would doubtless find it an almost insurmountable barrier to business.

But a broader view of the question should be taken. If we are to make progress and expand as we would like, provincialism must be cast aside. There should be no disposition to curtail the rights of fellow-citizens, but Canadians generally should unite in the building up of the country. Legislation of the kind under consideration is not calculated to promote harmony, nor does it strength our commercial position in any way, but on the contrary tends to weaken the bonds of trade and good will which should exist between all the provinces.

The steps that are being taken towards securing the repeal of the Quebec law should receive the hearty support of every reader of this journal, not only on account of the manifest unfairness of the legislation, but also because any disposition on the part of provincial legislatures to usurp the functions of the Federal government in matters relative to trade and commerce should be curbed at the outset.

A HOME-MADE ECONOMIZER.

I once had charge of a small sawmill plant, consisting of a 25 horse-power engine and boiler. It was pretty hard at time to keep the steam up to the required pressure, especially when the fuel was green slabs. I thought it would be a good thing to put in a fuel economizer and water heater.

The boiler was of the fire-box type. The

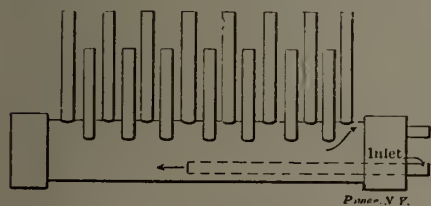

FIG. 1.

exhaust of the engine was turned up the smokestack and the heavy draft caused peices of bark to come through the flues continually; this kept them as clean as if they had been scraped with a patent flue scraper and then blown out. Taking advantage of this, I put in use a contrivance which effectually improved the steaming qualities of that boiler.

Fig. 1 is a sketch of the heater, which consists of a piece of 6-inch pipe, threaded at both ends and covered with two caps. A number of 3/4-inch pipes are plugged at one

end and screwed into the 6-inch pipe. The water tubes or quills were made short enough to lie below the water line when in position in the smok-box of the boiler, as shown in Fig. 2. The quills were put in only on top side, as shown, so that any sediment which might be in the water would not lodge in and scale them and cause them to burn out.

A short time ago I saw this same heater taken out of the boiler for inspection and the quills were not scaled at all. It had been in continued use for three years.

The position of the heater is such that it absorbs a great deal of heat and the feed water is fed through it as it goes to the boiler. Of course this device could hardly be used in

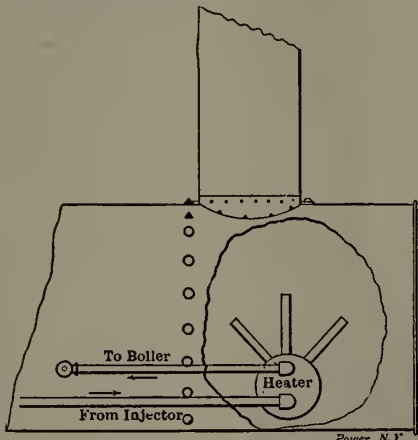

FIG. 2.

a boiler where the flues must be scraped from the smok-box end, as it stands directly in front of the flues.

The water connections between the boiler and heater should be large and ample; it is obvious that if they scaled and plugged up, there might be an over-pressure on the heater that would burst it. The lower connection, which is the delivery from the pump or injector, is extended in about half way, as shown by the dotted lines in Fig. 1, so as to insure circulation.

There was no check valve, nor anything of the kind between the heater and the boiler, so that there was always plenty of water in the heater. The check and stop valve were on the delivery to the heater.—J. M. Little, in Power.

PERSONAL.

Mr. Samuel S. Johnson, a millionaire lumberman of Minneapolis, died at Berkeley, Cal., on August 29th. Mr. Johnson was born in Canada in 1857.

The death took place last month of Mr. P. La Ferriere, president of the La Ferriere Lumber Company, Limited, Montreal and Murray Bay, Que.

Mr. J. D. Moody, manager of the Vancouver Lumber Company, left the latter part of August for a six weeks holiday to be spent at his home in Texas.

Mr. W. B. Tindall, of the Parry Sound Lumber Company, has been elected chairman of the Toronto branch of the Canadian Manufacturers' Association.

Mr. C. E. Moor, who has been superintendent of the sash and door factory of the Rat Portage Lumber Company at Winnipeg, has tendered his resignation.

Mr. Edwin Marshall, timber merchant, Nottingham, England, has been in Canada combining business with pleasure. Mr. Marshall buys considerable Canadian birch.

Mr. John Gray, of Coldwater, Ont., has tendered his resignation as bush manager for the Imperial Paper Company, Sturgeon Falls, Ont., and has been succeeded by Mr. Alexander Hamilton, of Warren.

Mr. T. Gibson is now on the road for the Rat Portage Lumber Company and will travel Manitoba and the Territories in the interest of their Vancouver mills. He will sell the product of these mills exclusively.

Mr. J. B. McWilliams, of Peterboro, Ont., for 33 years employed in the Ontario Crown Lands Department, has tendered his resignation. Mr. McWilliams has of late been inspector of Crown timber agencies.

Mr. R. H. Campbell, Ottawa, Secretary of the Canadian Forestry Association, was in Toronto last month making arrangements for the Dominion forestry convention to be held in Ottawa in January next.

Mr. Ira B. Myers, of St. John, N.B., has resigned from his position as representative of the United States Government at St. John after eight years' service. Mr. Myers was very popular among his business acquaintances.

Mr. William P. Fowle, superintendent of the Bellingham Bay Improvement Company's mill at Bellingham Bay, Wash., has resigned and has accepted a similar position with the Fraser River Saw Mills Company, of New Westminster, B.C.

Colonel Williamson and Mr. Marcus Crombie, who comprise the firm of Williamson & Crombie, Kingsbury, Que., recently visited British Columbia. Their trip to the Coast was in the nature of a pleasant jaunt and to see the vast timber resources of the West.

Mr. John Hendry, president of the British Columbia Mills, Timber & Trading Company, Vancouver, B.C., returned about the middle of September from his European trip. Mr. Hendry has not yet entirely recovered from his recent accident, but is gradually improving.

Mr. Arthur E. Millington has resigned his position as superintendent of the Lake Superior Corporation's pulp mill at Sault Ste Marie, Ont., and has been appointed general manager of the Spanish River Pulp & Paper Company, Webbwood, Ont. He has been succeeded by his brother, Mr. George Millington.

Mr. James T. Wheeler, a well-known citizen of Fredericton, N.B., died last month. He was a native of Kingsclear and in his capacity of lumber surveyor was well known along the St. John river. For some years he had been in the employ of Donald Fraser & Sons. He was sixty-seven years of age.

Messrs. Marcus Robinson and W. Forrest, two prominent timber merchants of Edinburgh, Scotland, have been visiting in Canada. Speaking, in Vancouver, of the British Columbia timber, Mr. Robinson stated that he expected it would be more largely used in shipbuilding in Great Britain in the near future.

Mr. S. J. Sutherland, who for many years has been president of the Sutherland-Innes Company, manufacturers of cooerage stock, Chatham, Ont., and New Orleans, and who has lived at the latter place, has retired from the active management of the concern and accompanied by his family will spend some time in Europe.

A telegram received at Fredericton, N.B., on September 20th, announced the death of Mr. William Sewell, a well-known lumberman of Lincoln, N.B., which occurred at St. Valliers, Que., from heart trouble. Mr. Sewell, who was 68 years of age, had spent most of his life in lumber operations. For a number of years he was engaged with the Cushing Company, and later with R. A. Estey. During the summer he worked as foreman for Glasier & Sons, and had accepted a similar position for the coming winter with John A. Morrison.

There passed away at Peterboro, Ont., on September 7th, a pioneer lumberman, in the person of Mr. William Snyder, aged ninety years. Deceased was born at Dickenson's Landing, near Cornwall, Ont., and engaged in business first at Montreal and later at Peterboro. He eventually embarked in the lumber business and in 1855 built and operated the saw mill which stood where the present waterworks pumping station at Peterboro is situated. Some years after he bought the mill at Auburn. His last operations were at Atherley, near Orillia, where he had a saw mill for some years. During the last two decades he has lived retired at Peterboro.

MODERN LOGGING METHODS IN THE WOODS

Ever since Pharaoh tried to reduce the cost of his bricks by cutting out the straw, and to increase his daily output by shoving up the speed of the poor Israelites a notch, man has been striving to get more for his money, and this growing desire to get more has increased in greater ratio than the means of getting it.

Time was when human energy measured the

machinery age—the day of increased speed in the making and decreased cost in the doing; yet with all the marvelous labor-saving devices of our time, in no field of industry has the revolution been so complete or greater opportunities offered for cutting costs than in the reduction of our immense forests, the handling of logs from the stump to the saw mill. As

in all productions where large bulk is a necessary feature, the item of transportation demands first consideration, and especially has this been true in the logging industry.

Realizing that the haulage or transportation of logs constituted so large a portion of their "cost at the mill", modern loggers have been quick to realize that by substituting the steel rail and logging car for the slow going logging sleigh, not only costs might be materially reduced but time and losses as well. Instead of depending on ice and snow for their movement to the creek or mill, the logging train insures continuous operation throughout the year. The

uncertainties, too, of the drive, the loss of stranded logs, and the possibility of fire and worms when hung over for a season from lack of water, are thereby eliminated. Thus the first real innovation in the woods had its beginning.

As one improvement oft begets another, so improved ways of transporting logs soon demanded modern ways of handling them. With the period of operation doubled and transporta-



NOVA SCOTIA : THE "MCGIFFERT" LOADING LARGE LOGS AT BRIDGEWATER.
After completing the first tier car is moved forward so that rear end may be loaded.



MISSISSIPPI : A "MCGIFFERT" LOADER IN THE SOUTH HANDLING LONG ONES.
Note the manner in which it permits empty cars to pass under or through itself.

limit of production and the amount produced depended solely on the number of workers, but with man's ever present appetite for "more", he soon discovered that the quickest way to get the start of the other fellow was through his brains, by devising machines that would do more work than a man could, and ever since he's been thinking up new methods or scheming to improve the old ones until this insatiable thirst for greater results has evolved the

tion facilities quadrupled, the necessity for better loading methods was imperative.

While the logging railroad has greatly augmented lumber operations, it is nevertheless merely the adaptation of an existing institution to a new field; whereas the steam log loader is an original creation conceived and devised for a specific purpose, without which the magnitude of present day operations would be impossible.

Increased speed and decreased cost in loading were of course the main object, yet the question of bringing logs up to the track for less money, the matter of wear and tear, reduced delay to rolling stock, and last but not least, greater independence of the swith engine at all times, were features also considered and embodied in this "wizard of the woods".

Constructed entirely of steel, powerful and rapid in its work, yet easy and economical to operate, the McGiffert log loader to-day represents the acme of ingenuity and skill, and is one of the most potent factors in the solution of modern railway logging.

Self-propelling, this labor saving machine is at once loader, locomotive and skidder combined, and can readily move itself or its cars wherever and whenever desired, greatly reduc-



MONTANA : THE "MCGIFFERT" MACHINE THAT LOADED 215,000 FEET OF LOGS IN EIGHT HOURS.
Observe the few men required in its operation.



MICHIGAN : A DECKER LOADER PUTTING ON THE LAST LOG IN A MICHIGAN WOODS OPERATION.



FLORIDA: BRINGING UP "BIG FELLOWS" WITH AN ACME STEAM SKIDDER. Note the two skidding lines in use at this end.

ing switch bills and the usual delays incident thereto.

By an ingenious arrangement in this device, the trucks may be swung outward and upward, allowing the machine to settle so that it rests solidly upon the ends of the ties, supported by



TEXAS: AN ACME SKIDDER HANDLING LONG TIMBER.

four strongly built and rigidly fixed legs, thus rendering possible the free passage (under and through itself) of the empty cars ready for loading. This is a feature which enables one body to pass another on one and the same track.



W. VIRGINIA: THE DECKER LOG LOADER, A SELF PROPELLING STEAM LOADER DESIGNED FOR SPECIAL CONDITIONS.

The McGiffert loader is adaptable to all conditions whether it be on standard or narrow gauge track, and loads advantageously whether the logs are above or below the rail, on high ground or from a swamp, close to or at a distance, and because of its strength and wide base is peculiarly fitted for skidding up to a distance of six to eight hundred feet each side of the track.

In support of this claim a Pennsylvania operator says he "skidded a log

scaling 2000 feet a distance of five hundred feet over rough ground and loaded it in fifteen minutes, an undertaking that under existing conditions would have required a team and five men five or six hours." In short, it fits into almost any phase of log handling and at a great saving over other methods.

As to the hoisting power and durability of this "giant of the woods," an idea may be formed from the testimony of a New Mexico owner who claims that his machine has lifted logs weighing 18,000 to 20,000 pounds, and a Texas lumberman says they "operated the loader from January 2 to June 21 without losing a single day." This is but further evidence of its strength and freedom from repairs.

The capacity of the McGiffert, like other machines, depends largely on the conditions attending, the size of logs to be loaded, distance from the track and manner in which they lie, and the experience of the operator and crew. An Arkansas firm reports that with a green crew, 114,000 feet were loaded the second day. Its speed ranges from this quantity up to 215,000 feet, a recent eight hours work accomplished in Montana. In fact, "10 cars per hour" comes from West Virginia and as high as 103,000 in three hours was claimed by a McGiffert owner in Mississippi. The highest of these records were, of course, attained under very favorable circumstances, but they only go to show the almost unbelievable possibilities of this machine. Even the very lowest average is more than double what can be performed by the old horse and man method.

That the saving feature of this device may be the better appreciated, one party writes that "it saves eight men and two teams in daily loading," while another says, "though inexperienced, have no difficulty in doing the work of three crews of team loaders, and will do even better." And still another claims, "it reduced our loading expenses fifteen dollars per day, besides considerably more on switching." In an actual test of two operations made by a party in West Virginia for the express purpose of determining the difference in cost when skidding and loading with McGiffert loader at one place, and teams at the other under exactly the same conditions, the

saving amounted to \$1.07 per thousand in favor of the machine. Surely these results speak volumes in favor of this labor saver.

The Acme skidder, a self-propelling, heavy and powerful machine, capable of effectively working a distance of 1,000 feet or more from the track, has fully proven its usefulness in many of our large undertakings. It is built entirely of steel and iron and equipped with two distinct double engines of four drums each. Two of the drums on each engine are for skidding lines, and two for side guy lines. Four lines for skidding are provided by this arrangement, which can be operated at the same time without interference one with another, and independent of each other. It thus covers a swath two thousand feet or more in width. The arrangement for guying and the self-propelling feature render it capable of moving from one point to another along the track with rapidity and ease.

That every phase of log handling may be met as circumstances demand, other devices are used, among which is the "Rapid" style of loader, a light, portable log loader, especially desirable for the smaller operations. This loader is mounted on a strongly braced frame of steel construction and designed to use on flat or logging cars by sliding over the top from one to another, as the loading progresses. The sliding operation is accomplished with a



MISSISSIPPI: LOADING A TRAIN LOAD OF HEAVY LOGS WITH A "RAPID." As each load is completed the loader is slid back on to the next car (under its own power.)

cable on one of the engine drums expressly arranged for the purpose. It can also be arranged for use on a logging sleigh for loading logs on sleighs at any point in the woods when cars are not used. It is powerful, and as the name implies, Rapid, very efficient in loading or skidding and a most satisfactory machine where conditions do not require the heavier and self-propelling machines.

The Clyde Iron Works, of Duluth, Minn., who manufacture these machines, make a specialty of log handling tools and machinery, and design particular equipment to suit any operation where something out of the ordinary line is required.



WISCONSIN: THE "RAPID" LOADER FROM LOGGING SLEIGH.



FOURTEENTH ANNUAL CONVENTION OF HOO-HOO.

Upwards of one thousand Hoo-Hoo were present at the fourteenth annual convention at Portland, Oregon, on September 9th. The Portland members "made good" and gave the visitors a splendid time. Snark of the Universe, C. D. Rourke, of Urbana, Ill., presided at the business sessions. The delegates were welcomed by the Mayor, the president of the Chamber of Commerce, and others. The annual address of the Snark spoke of the great prosperity of the Order, the concatenations of which had extended over the entire country from the Dominion of Canada to the Florida Straits.

The recommendations of the Snark were that the actual expenses of the members of the Supreme Nine should be paid from the funds of the order; that the Scrivenoter's salary be increased to \$1,999.99; that the annual meeting be held in some other month than September; and that the distress fund be increased.

The Scrivenoter's report showed a balance on hand of \$7,780.18, the largest ever reported. One hundred and twenty-five concatenations were held during the year. For number of concatenations held and men initiated, this breaks all previous records, surpassing what was regarded as probably the high water mark of last year. A comparative statement of concatenations held and men initiated from the beginning is as follows:

1892.....	15 concatenations	166 men.
1893.....	28 concatenations	458 men.
1894.....	87 concatenations	1,575 men.
1895.....	131 concatenations	1,393 men.
1896.....	92 concatenations	873 men.
1897.....	68 concatenations	687 men.
1898.....	74 concatenations	756 men.
1899.....	85 concatenations	861 men.
1900.....	83 concatenations	928 men.
1901.....	70 concatenations	747 men.
1902.....	77 concatenations	1,131 men.
1903.....	109 concatenations	1,721 men.
1904.....	119 concatenations	1,920 men.

In jurisdiction No. 8, under Arcanoper W. C. Laidlaw, Toronto, five concatenations were held and 95 candidates initiated.

It was decided to increase the Scrivenoter's salary to \$1,999.99 and to hold the next annual convention at Oklahoma City. On the recommendation of J. H. Baird, it was resolved to discontinue publishing the Hoo-Hoo handbook and as a substitute to print the names in a special edition of the Bulletin each year.

The election of officers for the ensuing year resulted as follows:—Snark—Robert D. Inman, Portland.

Senior Hoo-Hoo — A. C. Ramsey, St. Louis.

Junior Hoo-Hoo—George V. Denny, Savannah, Ga.

Bojum—Benj. F. Cobb, Chicago.

Scrivenoter—J. H. Baird, Nashville, Tenn.

Jabberwock—E. Stringer Boggess, Clarksburg, W. Va.

Custocatian—Farley Price, Little Rock, Ark.

Arcanoper — Donald Ferguson, London, Ont.

Gurdon—E. Clark Evans, Seattle, Wash.

A concatenation was held on September 9th, at which 200 kittens found their way into Hoo-Hoo land. This broke all records, the next largest being 92.

THE NORTH-WEST'S TIMBER RESOURCES.

Investors for the last few years have been turning their eyes westwards inspecting our

to-day to get a car of spruce lumber unless orders have been previously placed ahead.

"A lumberman from the Maritime Provinces remarked the other day that if they had only invested in the swamp lands before the pulp industry started, a good turnover would have been the result, but the timber lands have practically all been bought up there to such an extent that the present investor, he says, has a very small margin to work on, and while the North-west is, relatively speaking much in the same position as they were years ago (so far as investors are concerned in this particular line), we have this distinct difference in our favor that owing to the immense tide of immigration pouring in, the advent of the "Iron House" continually stretching out feeders to the steadily building main line over the boundless prairie of the west, which will eventually reach



LOG DRIVE ON THE LITTLE SWAN RIVER, NORTH SASKATCHEWAN TERRITORY.

lands and as a result millions of acres have been disposed of and settled, but it is surprising how little is known about the timber resources.

This particular industry, while limited to few customers as compared with land sales, is essentially a prime factor in the welfare of a country. In conversation with Mr. D. B. McDonell, of Winnipeg, who makes timber limits a specialty, he said:—"It would appear that this branch of industry, in the eyes of the Old World, is still in its infancy, and so it is in a manner, but the fact must not be lost sight of that the trees have blossomed and considerable ripe fruit picked in the way of the manufactured article, as borne out by the fact that fifty million feet was sold in the Northwest in 1897, twelve hundred million feet was sold during the fiscal year ending June 30, 1904, 332 million of which was consumed in Manitoba, and strange as it may appear, while there are a number of mills in operation, it is impossible

from ocean to ocean, the investors of to-day, says Mr. McDonell, have not only the same opening missed in the past, but the immediate prospects of realizing on their venture. There are numerous propositions, both for lumber or pulp wood, or both combined."

Mr. McDonell was asked as to the amount of timber available, and after a thorough investigation with careful calculation, including many trips west to British Columbia and north into Saskatchewan and Manitoba, he stated:—

"Approximately, at the time of writing and tributary to railway facilities, two billion two hundred and sixty-five million feet are available, which to manufacture would cost roughly speaking \$8 per M. (some blocks less) and the commercial value of which would be from \$15 to \$22 per M. Compare these margins with that of other countries, and the practical man will see that his investment is all that can be desired."

"STERLING" OILS

FOR SAW MILLS

WE SOLICIT ORDERS
TRADE LARGE AND SATISFACTORY
OUR AGENTS WILL CALL WITH "STERLING" CYLINDER,
ENGINE, DYNAMO, MACHINE AND SPECIALTY OILS

Greases, Packing, Waste, "Copperine," Ready Mixed Paints, Varnish, Red and Black Roof Paint; Smoke Stack Black for Boiler Fronts and Sawmill Refuse Burners, White Lead, Dry Colors, Etc.

Canadian Oil Co., Limited
Strachan Avenue, TORONTO, ONT.

Please mention THE CANADA LUMBERMAN when corresponding with advertisers.

Galt Machine Knife Works



MACHINE KNIVES OF EVERY DESCRIPTION
FOR **Woodworking Machines**
... Send for Price List ...
The Peter Hay Knife Co., Limited - Galt, Ont.

WESTERN CANADA

Western Offices of The Canada Lumberman,
720-721 Union Bank Building, WINNIPEG, MAN.; 536 Hastings Street, VANCOUVER, B. C.

CHINA BUYING CANADIAN MACHINERY.

The well known words "Made in Canada" will henceforth find frequent use in China's saw mills when speaking of the machinery used. With the sailing of the C.P.R. steamer "Empress of Japan" from Vancouver on August 14th there left for China the complete

Chinamen, while nominally employed by the local saw mills, are really in the employ of the Oriental concern. Their object is to find out all about the working qualities of the different machinery used in their respective mills. From time to time they reported to their chiefs in China. These reports were carefully given

this has also come to light. When H.R.H. the Prince of Wales was in Vancouver, in 1901, he visited the Hastings saw mill. A log 110 feet long and 54 inches in diameter was cut in the presence of the Duke, who was very deeply impressed with what he saw and apparently more particularly with the machines that did the work, for he enquired where they were manufactured. Being advised that the Peterboro company were the makers, he immediately made a note of it. On returning to London the Duke is known to have talked about his visit to the Hastings mill, and it is quite evident that his notes as to where the machinery was made were put to good use, for from London itself have come agents of the Chinese lumber firm to inspect the Canadian machinery. Their information was to supplement the reports of those Celestials employed in the mills.

Mr. Robert Hamilton, who was seen by these agents, merely gave them the names of the various mills in the province using his firm's machinery. Their report was also most favorable.

The saw mill equipment just shipped to the Wan Yip Company consisted of a single circular saw mill with a cutting capacity of 75,000 feet per ten hours. The mill building has been so laid out that it can be turned into a double mill at any time desired. The other machinery includes a saw husk frame, "Pacific Coast" carriage and friction feed works, "Pacific Coast" pattern; a double geared log jack, "Pacific Coast" pattern; a "Pacific Coast" gang edger; "Pacific Coast" cut-off saw and "Pacific Coast" turners.

Power is supplied by a heavy Corliss frame slide valve engine, 600 h.p., with heater, boiler feed and pump.

Owing to the difficulties of transportation the Hamilton Company arranged with a Hong Kong firm to supply the boilers, of which there will be four of 150 h. p. each, 72" inches diameter and 18 feet long, with a working pressure of 125 lbs.

The planing mill equipment consists of one large revolving bed surface planer 24 x 10, one heavy "Pacific Coast" moulding machine, a 36 inch band saw, a "Pacific Coast" re-saw machine and a complete outfit for making sash, doors and blinds. All the shafting, pulleys, bearings, belting, and in fact everything necessary, was supplied by the Wm. Hamilton Company. Next year they intend putting in a double cutting steam tension band mill and a 53 inch Hamilton oscillating gang saw, etc.

It is reported that Mr. W. P. Dutton, of Winnipeg, has severed his connection with the Elk River Lumber Company.

Mr. Gibson, of the Gibson Lumber Company, Winnipeg, has just returned from a business trip and reports business as very good all along the line.

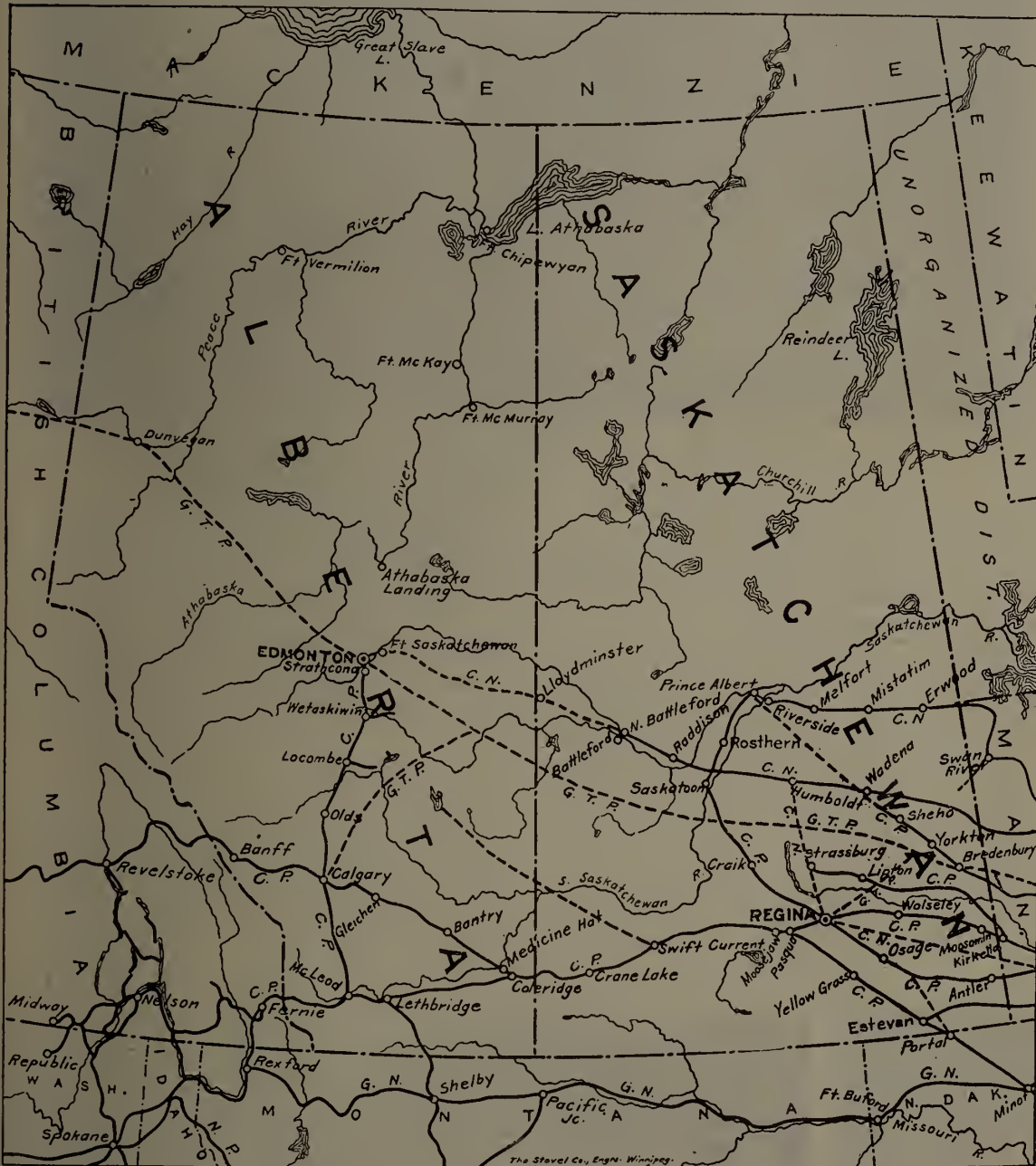

OUTLINE PLAN OF THE NEW PROVINCES OF ALBERTA AND SASKATCHEWAN, Where British Columbia Lumber and Shingles Find a Large Market.

equipment of machinery for a modern saw mill that is being erected in the Celestial Empire for the Wan Yip Timber Company. The story of why the Chinese capitalists chose Canadian manufactured machinery in preference to all others will probably prove interesting to the readers of the CANADA LUMBERMAN, and also serve to illustrate the patience and foresight of the Chinaman.

As far back as 1891, representatives of the Chinese lumber firm have been located in different saw mills on the Pacific Coast. These

and carefully preserved until such time as the Chinamen were ready to buy.

After due consideration the decision of the heads of the Oriental firm was that a Canadian firm—the Wm. Hamilton Manufacturing Company, of Peterboro—was the right firm to buy from. The opinion of the Chinese, based on the reports obtained from their delegates in the Western saw mills, to use their own words, was that the Wm. Hamilton Company's machinery "give no trouble."

Another interesting story with regard to

THE MUNDY LUMBER COMPANY

A Great Lumbering Enterprise at Three Valley, British Columbia

Two years ago nobody dreamed that picturesque Three Valley Lake, slumbering amid its mountain fastnesses, in the Eagle River Pass in British Columbia, sixteen miles west of Revelstoke, was destined to become the scene of one of the most important lumbering enterprises in the Interior. Nobody expected that the expert eye of the practical lumberman was here to find a mill site designed by Nature better than could be fashioned by the hands of man, and no expense for utilization beyond its equipment. Yet here was such a site, the like of which is rarely found, located almost against the road-bed of the great transcontinental railway, the Canadian Pacific.

The unexpected has happened, and the past few months have seen a wondrous change at Three Valley. Two years ago the neighborhood of the lake was known only to the trapper, and of the scores of thousands who yearly passed it in the railway trains and admired the beauty of the scenery, none dreamed that on the further shore of the lake existed one of the finest lumbering forests in British Columbia. It remained for Mr. A. McRae, of Revelstoke, to grasp the opportunity that so many now learn to their regret they missed, though lying at their very doors. McRae heard of the magnificent resources of Three Valley, and determined to investigate for himself. Although an old hand in the mountains he was amazed at the wealth of timber that he saw. It was on Dominion lands, and he arranged to take it up with a view of interesting capital in its development. As a result the capitalists now comprising the Eagle River Lumber Company and the Mundy Lumber Company investigated the proposition. They were expert lumbermen with many years of successful experience in the Eastern States. They were delighted with the result of their investigation and took up the timber berths they now hold, aggregating 160 miles. They then proceeded to organize the Eagle River Lumber Company, which owns the limits, and the

Mundy Lumber Company, which has erected the mill and will run the manufacturing end of the business.

The Eagle River Lumber Company is capitalized at \$1,000,000, and the investors consider the value of the timber in these limits worth all of 100 cents on the dollar on that capitalization.

The Mundy Lumber Company is organized with a capital of \$50,000, which will be in-



VIEW OF MUNDY LUMBER COMPANY'S SAW MILL, TAKEN HALF-MILE DISTANT.

creased from time to time as required to conduct the manufacture of lumber in all its branches, it being the intention of this company to add the necessary machinery to their plant as the business demands it.

The following gentlemen constitute the officers and proprietary of the Eagle River Lumber Company: F. W. Davis, president; S. A. Mundy, vice-president and manager; F. P. Schoonmaker, secretary; W. W. Bell, treasurer; directors, C. P. Collins, John McCrum, E. R. Schoonmaker, G. H. Mills, W. W. Bell, F. W. Davis, S. A. Mundy, H. Y. Telfer, and D. G. Cooper, all of Bradford, Pa., except Messrs. Telfer and Cooper, who are from Collingwood, Ont.

The Mundy Lumber Company composed is as follows: S. A. Mundy, president; E. R. Schoonmaker, vice-president; F. P. Schoonmaker, secretary; W. W. Bell, treasurer; directors, all the officers, with the addition of Messrs. C. P. Collins, John McCrum, and Geo. H. Mills. These gentlemen are all from Bradford, Pa.

THE TIMBER

on the Company's limits is mostly cedar, but there is a considerable proportion of white pine, fir, and spruce. The growth of timber is wonderful, and where logging operations are now going on it will cut 150,000 feet to the acre, while the Eagle River Company's holdings

will probably average 50,000 feet to the acre all round. Much of the timber is large, trees being as much as 12 feet in diameter. These trees will give a magnificent cut of clear lumber; as showing the size of the timber growing on these limits we publish herewith an engraving showing five persons with their arms outstretched, covering only half the girth of the tree.

LOGGING OPERATIONS.

Last Fall, under the management of Mr. E. R. Schoonmaker, the vice-president of the Mundy Lumber Company, a logging camp was put in on Three Valley Creek, and steps taken to improve the creek for logging purposes. Later a contract was let to Mr. E. L. Kinman



A GIANT CEDAR ON THE MUNDY COMPANY'S LIMITS.



DAM ON THREE VALLEY CREEK, USED FOR COLLECTING LOGS AND RAISING A HEAD OF WATER TO CARRY LOGS DOWN CREEK.

to supply 50,000,000 feet of logs to the mill. He brought over his logging plant from Trout Lake, effected further improvements to the Creek for floating logs, and built two substantial splashing dams. He also turned in part of Frog Creek to Three Valley Creek to increase the volume of water for splashing purposes. The first dam is a mile up the creek, and the second is about a quarter of a mile further on. The creek has been cleared out and straightened, and a flume built at each dam with a

facility with which they handle the heaviest logs over the roughest ground is amazing, the logs being delivered right into the splashing booms with no manual labor other than fixing haulage cables and clearing away obstructions in front of the logs.

So heavy is the timber in which these logging engines are now operating that, to allow room for the logging plant to work, only half the timber can be felled and taken out at a time, and the fellers and the logging plant will have to be taken over the ground a second time in order to complete the logging of it. Clarence Brownlee is foreman of the logging operations.

THE TOWNSITE.

The inauguration of the Mundy Lumber Company's enterprises has established a growing townsite at Three Valley. In addition to the Company's offices and store, dwellings for the employees have been erected. The townsite occupies a beautiful situation at the west end of Three Valley Lake, where the Eagle river leaves the lake, and it will ere long grow into a point of considerable population and importance. The railway station is a third of a mile distant, and the railway authorities are being urged to move to the new townsite, where practically all the traffic now is. This will probably be done. Opposite the townsite is a pretty little island called Pleasance Island in honor of Mrs. Mundy. A convenient dock for the accommodation of the

Company's steam tug has been built on the lake shore alongside the company's offices. A water supply has been put in. There is a daily mail service east and west, and a telephone has been installed which gives connection with Griffin Lake, from which the Company has the advantage of telegraphic communication with the outside world. A complete electric lighting system is being put in from the mill to light the townsite and docks, so that in a short time Three Valley has secured all the advantages of civilization.

THE MILL.

The "go" that has been put into the construction of the mill is evident from the fact that on May 1st there was no machinery on the ground, while by August 1st the mill was ready for operation. The site chosen for the mill is on the south side of the lake at the west end, and no better site could be found for the economical operation of the lumber industry. A railway spur runs right into the mill from the Canadian Pacific Railway Company's main line, and the mill is thus within three days' freight haul from Vancouver on the west and Calgary on the east. The Mundy Lumber Company have here magnificent booming facilities, their main boom in the lake being a mile long, while a mill has been built on a



MR. S. A. MUNDY, President of the Mundy Lumber Company and Vice-President of the Eagle River Lumber Company.



MR. F. W. DAVIS, President Eagle River Lumber Company.

water-tight water gate fitted to the head of each flume. The upper dam is 335 feet across, and affords a storage space of three-quarters of a mile up the creek.

The steam logging plant consists of two engines with their equipment. One of these engines has two 10 x 12 cylinders at 160 lbs. pressure, running 360 revolutions per minute. It is fitted with a double hauling drum. This engine can handle logs for a radius of a mile around. These engines were built by the Washington Iron Works, of Seattle, and the

cove of the lake which affords a naturally sheltered boom for holding the log supply for the mill available right at the foot of the log ladder. There is ample yard and dock accommodation. Docks will be built along the lake shore and lighted at night by electricity; while the yard will be in a safe position in case of fire, being cut off from the mill by a hill, which affords a natural buffet between the mill and the yard. A mountain stream comes down to the mill, from which is derived the water supply for the boilers; and by erecting a tank or dam on the mountain side a first class high pressure



MR. E. R. SCHOONMAKER, Vice-President Mundy Lumber Company.



MR. F. P. SCHOONMAKER, Secretary Eagle River Lumber Company and Mundy Lumber Company.



MR. W. W. BELL, Treasurer Eagle River Lumber Company and Mundy Lumber Company.



MR. JOHN MCCRUM, Director Mundy Lumber Company.

water service can be made available in case of fire.

The mill has been erected with two main features in view—economy of production and safety from fire. The boiler house is 28 feet x 60 feet, built of solid brick and iron, making this one of the safest mill buildings in the province so far as precautions against fire are concerned. The burner has been located over a lofty ridge situated on the east side of the mill, and this ridge forms a perfect cut-off between the mill and the burner, the refuse lumber being carried to the burner by means of a conveyor. The yard, loading and sorting platforms are located on the west side of the mill. The mill building proper is 152 feet in length by 44 feet in width.

The motive power of the mill is supplied by three horizontal return tubular boilers, 72 inches diameter, 18 feet long, with 4-in. tubes. The smoke-stack is 60 inches in diameter, 90 feet in height, and is fitted with ladder and spark arrester. The main engine is a beautiful piece of machinery, of 250 horse power, and took first prize at the World's Fair. The fly-wheel is 12 feet in diameter. This engine was built by the Buckeye Engine Company, of Salem, Ohio. This engine has a novel feature in that the governor is on the fly-wheel, which gives superior regulation of the speed of the engine. The engine is installed on a massive concrete foundation. There is also a condenser, and a duplex steam force pump for feeding the boilers in case of necessity, or for fire purposes.

The electric plant consists of a 450-light machine, supplied by the Milwaukee Electric Company. This dynamo is driven by a separate engine of 100-h.p. capacity.

Consistent with the company's policy of providing every possible precaution against fire, a brick oil house has been built for the storage of all inflammable oils.

THE MILL PLANT

is up-to-date in every particular. The logs are raised from the boom by the travelling log elevator, from which they are kicked on to the log deck by a steam kicker operated by the scaler with his foot. A steam loader places the log on to the carriage, and a steam nigger turns the log when necessary. The carriage is steel, with three log seats and knees openings 72 ins. from the saw line. The carriage is fitted with patent hammer dogs, and there are pneumatic cushions for bumpers at each end of the carriage run. The set for the logs is worked with steam, and the feed is a gun-shot feed 42 feet long.

The saw itself is what is known as a left-handed 14" Allis double cutting band, with extended bed, and the saws travel at the rate of 8500 feet a minute. From the saw the lumber is carried by live rolls, the larger timbers going right through the mill, while the smaller sizes are switched off to the edger. This is one of the best machines made, with latest labor saving devices. The saws are fitted with Hoe chisel teeth. Live rolls again carry the lumber from the edger, the off-cuts going to the slasher—a five saw machine which cuts all the waste into 3 feet lengths—

and the better grades passing on to the trimmer, from where it is carried over a 60 ft. sorting table. It then passes to the planing mill and is worked into the various kinds and descriptions of the finished products of the forest. The trimmer is fitted with patent saws, which leave the edges perfectly smooth. The planing mill is 60 feet x 40 feet and the power is furnished by an independent engine of 100 h.p. The shavings and dust are drawn off by a cyclone fan and go to feed the furnaces. The auxiliary plant of the planing mill consists of a steam saw setter, a resaw and rip-saw for mouldings, and automatic knife grinder. The band saws are filed in a separate room, where special machines for the different operations are fitted up. This machinery, too, is furnished with a separate engine. The capacity of the mill is 100,000 feet per day, running double shift. The plant was supplied by Waterous Engine Works Company, Limited, through their Vancouver agent, Mr. Hugh Gilmour. This firm has the reputation of turning out high grade saw-mill machinery.

A shingle mill, 40 feet x 16 feet, is built on the lake side of the mill, and it is expected that the output will be in the neighborhood of 150,000 per day. Lockport and Perkins machines are being used, and the Company hope to demonstrate that shingles of the very highest grade can be turned out on this class of machine. This addition to the sawmill will utilize a lot of timber that cannot be used in the sawmill, but in which there is a great deal of clear lumber suitable for making first-class shingles.

Mouldings of all kinds will be turned out by the planing mill. The shingles and lumber will all be air-dried, but a small steam kiln will be put in for handling mouldings. There is a well equipped blacksmith shop at the mill. Altogether, the Mundy Lumber Company bids fair to fulfil what it has started out to do, namely, to supply the trade with rough and dressed white pine and red cedar for every purpose.

GENERAL.

The Mundy Lumber Company is already, directly and indirectly, one of the largest employers of labor in the district. At the mill there are over 75 men on the pay roll, and an equal force is at work in the logging camps.

The Company's store and office building is 100 feet by 20 feet. The store is subdivided into grocery, dry goods and meat departments, in all of which large stocks are carried. The store is in charge of Mr. James Lane, who is also the Postmaster of Three Valley. On the upper floor of the building are the Company's offices and the living rooms of the manager and his staff. The offices are well furnished and equipped for work. A large boarding house has been built, covering a ground space of 70 feet by 40 feet. It is prettily situated on the lake shore, and is quite pretty architecturally. Stores are delivered right at the door by the Company's tug. The main dining room is 16 by 38, while a smaller one two feet narrower allows of the largest crew finding accommodation. There is a

verandah all round the building. A laundry has been built on a small island in the Lake, so that the best sanitary conditions can be obtained.

The Company own a tug which is kept hard at work. It has been named "Commodore McRae," after the popular postmaster of Revelstoke, and is in charge of Captain Patch.

The Company's operations are under the active management of Mr. Mundy, president of the Company, who is one of the most up-to-date lumbermen in this country.

The Mundy Lumber Company has a big field of operation before it, with first-class reserves of timber of an extent which will supply the raw material for many years to come. It has all the advantages of natural conditions and transportation that a mill could secure, and, with its up-to-date plant and practical management, is destined to take a prominent place in the great industrial enterprises of the West. We wish the Company all success in its operations.

SPRAGUE-McLEOD NUPTIALS.

Winnipeg society was in a flutter over the wedding of Harold Champion Hawkins Sprague, only son of Mr. D.E. Sprague, the well known lumberman and mill owner. Harold Sprague is not only a full fledged lumberman, but is also one of the prominent local Hoo-Hoo.

Society turned out en masse and donned its finest clothes for the occasion, so that the scene in the church and afterwards at the house was a most brilliant one. The bride, Miss Kathleen Louise McLeod, eldest daughter of Mr. and Mrs. W. W. McLeod, is one of the most popular girls in Winnipeg society.

Holy Trinity church, the scene of the happy event, was beautifully decorated, the altar being banked with white asters, sweet peas and daisies, and the chancel railing almost hidden with ferns and daisies, with ropes of smilax, studded with sweet peas, festooned overhead. The Ven. Archdeacon Fortin officiated and the beautiful choral service was used, the choir being in attendance.

Amidst showers of good wishes they left on the 5.20 train for the south, to spend a few days in Chicago before going to New York and other eastern points.

The groom's gift to the bride was a lovely ring, set with Burmese ruby and two diamonds; to the bridesmaids handsome art brooches, set with rubies and boroque pearls; to the groomsman gold cuff links, and to the ushers pearl scarf pins.

Mr. Tomlinson, the sales manager of the Red Deer Lumber Company, has returned from an extended trip to Red Deer Lake and other North-West points. He will close up the Winnipeg office and move to Red Deer, Sask., in a few weeks.

Considerable excitement has been caused at the Pacific Coast by the rumor that large quantities of American shingles were being imported into the Northwest, through Winnipeg, in an endeavor to cause a break among the members of the B. C. selling agency. There was no truth in the rumor whatever, and the representative of the CANADA LUMBERMAN was able to assure the B.C. firms that nothing of the kind existed. The shingles of U. S. manufacture that come into Canada are inferior to B. C. shingles and are worth 50 cents to 75 cents less.

FOR THE CAMP

We have a very suitable lot of goods for camp supplies. We make this kind of trade a specialty. You who are not getting suited just as well as you would like, try us for your next order, and give us a chance to demonstrate our ability to give you satisfaction in this very important department of your business.

H. P. ECKARDT & CO.

Wholesale Grocers

TORONTO

AMERICAN ENDLESS BED SINGLE SURFACER.

The illustration on this page shows the 30" x 12" American endless bed single surfacer manufactured by the American Woodworking Machinery Company, 136 Liberty Street, New York. This is a very strong and powerful machine intended for surfacing lumber of any kind for planing mills, box factories, bridge, boat and ship building, agricultural shops, etc., where a powerful feed is required and a large amount of surface is to be removed.

The main frame is very heavy, internally ribbed and has wide foot flanges. All working surfaces are planed and hand scraped, and cross girts are securely bolted to the main sides, making a solid frame as if it were

in diameter, 8" long; the cutting circle is 6"; speed, 3800. The cutter head pulleys are pneumatic.

The ways which carry the traveling bed are bolted to the main bed. They can be easily removed, replaced or repaired, when necessary, without taking the machine apart. They are 30 in. long and supported at each end as well as having two middle supports. The guides at both sides of bed allow the operator to run two or more pieces through at the same time.

The front and rear tables are adjustable and carry two rolls. These tables can be adjusted at their ends, which also prevents lumber from clipping on entering or leaving the machine.

The endless bed is driven by belt and compound

which are bushed with patent graphite bushing, requiring no oiling. Each section has independent pressure spring which can be adjusted for tension. The solid roll in rear of cutter head is made yielding by

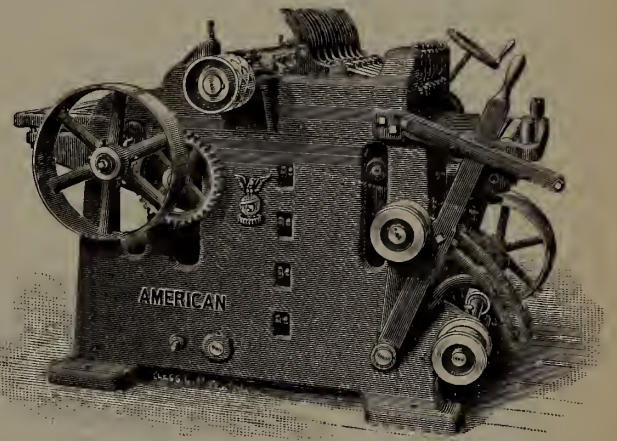

heavy spiral springs. A steel adjustable scraper is provided for this roll to keep it clean.

The power hoist for adjusting the bed is operated by clutch pulley for starting and stopping by lever at right-hand side of the machine, convenient to the operator—where he has a full view of the index plate. The hand wheel at the right of operator is for fine adjustment of table.

The adjustable tightener on feed belt is so arranged that slack is taken up when adjusting from 1/4 in. to 12 in., requiring only one feed belt.

BIRCH STAVES.

Staves promise to be an interesting feature of the market if things pick up a little later on. A good many of the coopers are looking out for cheaper staves. While elm is still chiefly used here, the outside shops have been turning more and more to oak, and lately to birch. It is figured now that the majority of shops in the small towns in the northwest use Southern oak staves, which they get for about a dollar less than elm. As for birch, it is growing in favor and bringing a better price. Coopers object to

it at first because it is harder to work, but those who have adopted birch are much pleased with it. Birch makes a handsome barrel, and no complaint has ever been received from them. The country mills have no dry kilns, and elm staves are generally sent air dried. The birch staves are kiln dried at the mill, so there is never any shrinkage.

—George Smiley & Sons, lumber and implements, Manor, N.W.T., are advertising their business for sale.

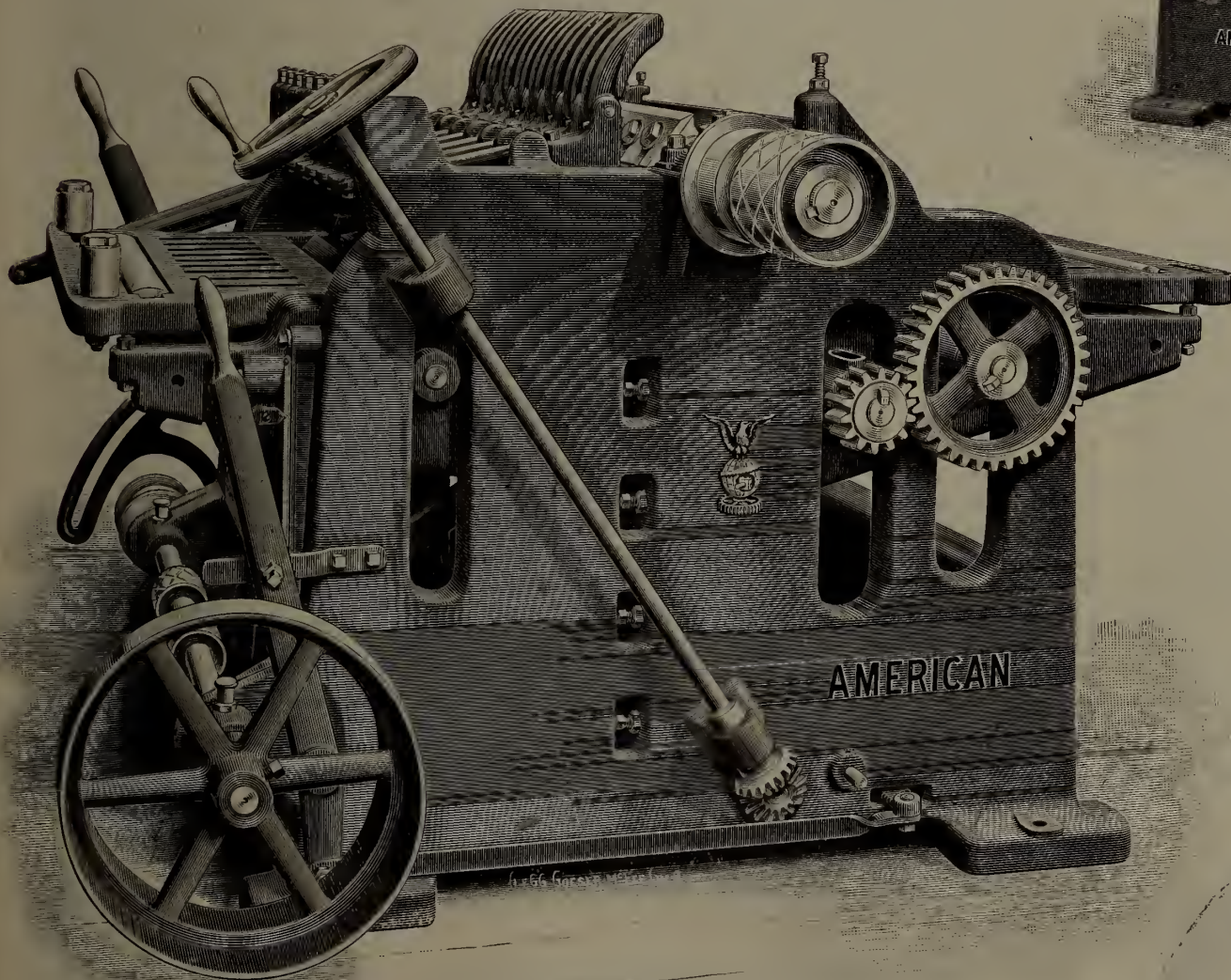

AMERICAN ENDLESS BED SINGLE SURFACER.

one solid casting. The cutter head boxes are cast solid on the sides of the frame, are self-oiling and 8 in. in length. The wear caused by the raising and lowering of the bed is taken up by means of steel gibs attached to the frame, which are adjusted by set screws.

The cylinder is a solid steel forging, three sided, tipped and carrying three knives. The journals are 2"

gears on both sides. Arrangements are made for taking up slack of bed. Rates of feed, 25, 40, 55 and 70 feet per minute.

The lags are supported at their extreme ends, as well as in the center, and extend practically the full width of the machine, making the wear equal the whole length of the knives.

The sectional roll is divided into 2 1/4 in. sections,

THE NEWS

ONTARIO.

—L. C. Poitras is announced to have disposed of his saw mill at Vernon, Ont.

—Joseph Snitchley has recently purchased Hugh Baird's saw mill at Markdale, Ont., and is continuing the operation of same.

—The late Samuel Bingham, of Ottawa, who was largely interested in lumbering operations, left an estate valued at \$277,360.

—J. R. Booth is pushing ahead the work on his new pulp and paper mill at the Chaudiere. The outlay involved will be about a million dollars.

—The Knight Bros. Company are building a new woodworking factory at Burks Falls, Ont. It will be 146 x 62 feet, with solid concrete walls.

—Reid Bros. have built a saw mill at Cockburn Island, in which they have installed the machinery formerly used in their mill in Amabel Township.

—It is reported that the C. Beck Manufacturing Company, of Penetanguishene, Ont., are considering the erection of a saw mill at Fort Frances, Ont.

—The Manning Wood Fibre Company, of Toronto, are said to have decided to build a factory in Brooke, a suburb of Owen Sound. The company will manufacture excelsior.

—Alex. McBeath, lumber dealer, and Henry Monteith, of the London road, Tuckersmith, have purchased a tract of timber land in the Parry Sound district and intend operating it next year.

—The saw mill of Little Bros. at Haileybury, Ont., was destroyed by fire on August 31st. An exploding boiler killed two men and injured three others. The loss of the mill is felt keenly, as it was the only source of lumber supply for Haileybury and Cobalt.

—The formation of the Fulton Lumber Company, Limited, has recently been completed, the head office being in Toronto and the capital stock \$25,000. The provisional directors are Elliott Fulton, Walter Fulton and George Fulton, lumbermen, of Fulton's Mills, Ont.; C. A. Barclay, lumberman, of Brougham, Ont.; and S. B. Woods, barrister, of Toronto.

—Gillies Bros., lumbermen, Braeside, Ont., some time ago purchased from J.R. Booth, of Ottawa, a timber limit in Temiskaming, a portion of which is in or adjoining Coleman Township, where the cobalt mining centre is now located. The limit is supposed to carry cobalt and every one is anxious to prospect. While Gillies Bros. have no right to the minerals, they claim that they can keep trespassers off the limit. It is probable that the Ontario Government will make an arrangement with the owner to surrender the portion of their claim immediately over the timber belt so that the Crown will be in a position to place the belt on the market.

—The incorporation was announced last month of

the Temagami Lumber Company, with head office at Orillia, Ont. The officers are well known lumbermen, namely: President, W.J. Smith, of John B. Smith & Sons, Toronto; Vice-President, George Gordon, of Geo. Gordon & Co., Cache Bay; W. J. Smith, George Gordon, John Barry, Thos. F. Strong, Robert Booth, and H. J. Bartlett. The company has purchased about 120,000,000 feet of pine which will be manufactured into lumber at Cache Bay and Callender. The pine comes from the famous Mackie tract, for which the late Thos. Mackie, M. P., of Pembroke, paid so large a figure at the last timber sale. It is expected to take seven years to cut this timber, but with their other operations the Company intend to cut between thirty and forty million feet a year. They already have a mill at Cache Bay, and another at Callender, and it is likely that a third mill will be erected at the latter places during the coming winter. Mr. Bartlett will continue to act as Canadian manager for White-neys, Skillings & Barnes.

MANITOBA AND THE TERRITORIES.

—Vodden & Wood have opened a lumber yard at Elkhorn, Man.

—E. W. Bean has established a lumber yard in Maymont, Alberta.

—The Lethbridge Lumber Company have opened a yard at Pincher, N. W. T.

—J. G. Ross, lumber dealer, Fielding, N.W.T., has sold out to Cowan & Company.

—Alex. Thom has sold his lumber business at Quill Lake, N. W. T., to Gardiner & Lyons.

—J. H. Sanderson, lumber merchant, Prince Albert, N. W. T., has started a branch in Vonda.

—The Jefferson & Miller Lumber Company, Stone-wall, Man., have registered a partnership.

—Currie & Company are announced to have decided to open a lumber yard at Vonda, Saskatchewan.

—The Prairie Lumber Company have sold their lumber yard at Hargrave, Man., to R. A. Knight.

—Ashdown & Bossons have built a new saw mill at Swansea River, Man., one of the growing towns of the West.

—Ferris Bros. & Company, lumber dealers, North Battleford, N. W. T., have opened a branch in Vermillion.

—The headquarters of the Red Deer Lumber Company will shortly be removed from Winnipeg to Red Deer, Sask.

—J. T. Thomas is constructing a dam at Gimli, Man., to operate grist and saw mills which he intends building in the near future. The machinery will be driven by a 20 inch water wheel and he expects to be

able to operate his mills eight months of the year by water power.

THE EASTERN PROVINCES.

—Tilton & Raymond have formed a new partnership in the lumber business at Stanstead, Que.

—McFarlane & Baird, lumber manufacturers, Hartland, N.B., have dissolved partnership, Mr. Baird continuing.

—The Pingstone Creek Lumber Company, Limited, Revelstoke, B. C., are negotiating for the sale of their property.

—Frank Scott, aged 28, was killed in Eaton's planing mill at Milltown, N. B., recently by being caught by the shafting.

—Alfred Adam and Arthur Dupuis have registered as the proprietors of the lumber business of Adam & Dupuis, Hereford, Que.

—While working in MacLaren's saw mill at Buckingham, Que., a man named Hayes was struck on the head by a slab and killed instantly.

—Adams & Hamelin is the name of a new lumber firm at Paquetteville, Que. The members of the firm are Alfred Adams and Roumald Hamelin.

—The Ingleside Pulp Company have built a new mill at Turtle Lake, N. B., which will be used to prepare logs for the Mispic pulp mill at St. John, N. B.

—An employee of MacLaren's sawmill at Buckingham, Que., met a peculiar death. A splinter from an edger struck him under the chin and penetrated upward through his brain, killing him instantly.

—It is reported that the Pearsons, the London, England, publishers, have completed negotiations for the acquisition of 2,000 square miles of forest land in Newfoundland, with the intention of establishing pulp mills on a large scale.

—Serious fires occurred last month on the headwaters of the St. John river. Several large tracts of valuable timber lands, in some of which St. John operators have an interest, were burned over. A quantity of logs left on brows last spring went up in smoke.

—In the September number the address of the Fred S. Morse Lumber Company, who are handling large quantities of spruce and cedar shingles from Quebec and are also wholesalers of southern woods, was given as Springfield, Ohio. This should have read Springfield, Mass.

—A terrible fatality occurred at Rood & McGregor's saw mill at New Glasgow, N. S., on September 19th. Clarence Cameron, aged 24, who was employed in taking away lumber from the saw, fell on the carriage and was thrown upon the saw and instantly killed.

TENTS

That are the acme of perfection, in all details of work. BRITISH ROYAL NAVY method of cut, workmanship and finish. MATERIAL used made in SCOTLAND by the Navy Contractors. Samples and prices are mailed on request.

TOBIN TENT & AWNING CO. OF OTTAWA Long Distance phone No. 432

CRAIG MINE CRYSTAL CORUNDUM WHEELS

Our Pure Crystal Corundum Saw Gummars have no equal for their Rapid, Cool, Cutting Properties.



Read the following from Bulletin 180 of the United States Geological Survey, which says:

"Often a distinction is made between emery and corundum, many persons not recognizing emery as a variety of corundum.

Emery is a mechanical admixture of corundum and magnetite or hematite. It is, of course, the presence of corundum in the emery that gives to it its abrasive qualities and makes it of commercial value, and the abrasive efficiency of emeries varies according to the percentage of corundum they contain."

Emery is imported, mined by Greeks and Turks and contains only about 25% corundum. Our Crystal Corundum is guaranteed to be 98% pure alumina, a Canadian product, mined and manufactured by Canadians for Canadians.

HART CORUNDUM WHEEL COMPANY, Limited, Hamilton, Ont, Can.

He was horribly lacerated. He was a native of lower Caledonia, Guysboro county, and unmarried.

—The A. L. Wright Lumber Company, Limited, has been organized for business, the officers being: President, George W. Fowler, M. P.; vice-president, Lewis A. Wright; secretary-treasurer, W. R. Wright. The company have just completed a new mill at Salisbury, N. B.

—The Thomas W. Flett Lumber Company, Limited, has been incorporated by T. W. Flett, John A. Flett and Margaret J. Flett, of Nelson, N. B.; C. J. Flett, of Melrose, Mass.; and W. J. Flett, of Boston. The capital is \$35,000 and it is proposed to carry on the lumber business of T. J. Flett at Nelson, N. B.

—Forest fires north of Moncton, N.B., have done considerable damage. The saw mill of George McSweeney at Gallagher Ridge was threatened, so Mr. McSweeney hired a special train and took about forty men from Moncton to fight the flames. The fire surrounded the mill and the men had a hard fight to save the property.

—Donald Fraser & Sons are now engaged in cutting out and turnpiking a road from their mills at Plaster Rock, N. B., direct to Trausers Lake, a distance of more than 30 miles. The road will be on their own property the whole distance. Henceforth they can haul their supplies from the station to the lake over an excellent, level, well-made road.

—The Chimalapa Land Company, composed of Canadian capitalists, are reported to have acquired 130,000 acres of valuable timber land in Mexico. George W. Fowler, M. P., is president of the company, and A. W. Wright, of Toronto, vice-president, while F. H. Hale, formerly member of parliament for Carleton County, N.B., will be superintendent of operations. Mr. Wright gives it as his opinion that there is an average of 500 cubic feet of mahogany timber per acre on the property. There is also a small quantity of Spanish cedar and some twenty other varieties of timber.

BRITISH COLUMBIA.

—The Rat Portage Lumber Company at Vancouver have recently put in a new gang edger, supplied by the Canadian Fairbanks Company.

—The Mundy Lumber Company have installed a complete exhaust system in their new mill at Three Valley Lake, B.C., supplied by the Canadian Fairbanks Company.

—The property of the Canadian Timber & Saw Mills Company, of Trout Lake, B.C., has been freed from indebtedness and arrangements are being made for disposing of the timber.

—O. E. Oleson, a millwright employed by the Vancouver Lumber Company, Vancouver, B. C., fell from one of the timbers, fracturing his skull. He died a few hours afterwards.

—The Northwestern Lumber Company has been incorporated by the British Columbia government, with a capital of \$10,000, to carry on the business of lumbermen, saw-millers and timber merchants.

—Alex. MacLaren, of the North Pacific Lumber Company, Barnet, B.C., has recently had a 45 horse power 3-cylinder engine installed in his yacht, "The Maple Leaf", by the Canadian Fairbanks Company.

—It is understood that Baker, Ryan & McNab, of Cranbrook, B.C., will build a saw mill on the Kootenay river at McConnell's ranch. The site is said to be favorable owing to excellent booming facilities.

—W. E. C. Koch, of Nelson, B.C., is constructing a saw mill on the Slocan river, about seven miles from Slocan Junction. It will be equipped with Waterous machinery and will have a daily capacity of 50,000 feet.

—S. C. Smith, proprietor of the Vernon Planing Mills, now has his mill at Penticton, B. C., in operation, cutting about 20,000 feet per day. The mill is of a semi-portable nature and was supplied by the Waterous Company.

—The King Lumber Company, Cranbrook, B.C., recently purchased a Fairbanks-Morse steam pump. This company have also installed a complete electric lighting plant in connection with their mill. A 60 light dynamo is in use.

—J. M. Pattullo, late of Tacoma, Wash., and J. A. Thomson have secured control of the Pacific Box Company, Vancouver, B.C., and intend considerably increasing the plant. The box-making equipment will be thoroughly modernized.

—The British Columbia Manufacturing Company has been formed at Revelstoke, B. C., to manufacture a stump burner invented by E. Adair. It is understood that it was recently tested in Vancouver and found to work very satisfactorily.

—The Kwaysie Bay Lumber Company are enlarging their plant to a daily capacity of 25,000 feet. They have purchased a complete new circular saw mill outfit from the Canadian Fairbanks Company. This company contemplates further improvements and additions in the spring.

—Jas. Leigh & Sons, of Victoria, are putting in a cement dry kiln and a couple of additional planers, one built by the Fay-Egan Company and the other by the McGregor-Gourlay Company. A new exhaust fan is also being added, the fan being supplied by the Boston Blower Company.

—Manning & Bruce, of Okanagan Landing, B. C., intend building a saw mill in the near future with a daily capacity of about 25,000 feet. They will manufacture fruit boxes to supply the local demand. They own some valuable timber limits in the neighborhood of Six Mile Creek and Shortt's Creek.

—The Fraser River Saw Mills Company have their mill at Barnet, B.C., ready for operations. The first million feet of lumber sawn will be used in further

additions to the mill, including a planing mill and shingle mill, both of large capacity, and a number of outbuildings and dwellings for employees.

—In connection with the announcement in last issue of the purchase of the mills of the British Columbia Box & Lumber Company, Vancouver, it should perhaps be explained that the transaction has no connection with the British Columbia Box Company, which is located on False Creek, and of which C. P. Moss is manager.

—The plant erected by the Monarch Wood Extracting Company, at Victoria, B.C., is now in operation. The company control a process for the extraction from native fir of turpentine and other products in which the wood is rich. The company, of which M. Calkins is manager, are offering \$4.50 a cord for green native fir.

—The remodelled mill of the Assiniboine Lumber Company, at Vancouver, B. C., started operations last month. The mill was formerly known as the British Columbia Box Factory. The new head of the enterprise is John Hanbury, of Brandon, Man., while the local manager is R. C. Ferguson, who was for many years manager of the Royal City Planing Mills. For some time the mill will run on cedar.

—The saw mill of the Elk Lumber & Manufacturing Company at Fernie, B. C., which was destroyed by fire on September 7th, was one of the most modern establishments in the West. It was built by American capitalists, including O. A. Robertson, of St. Paul, Minn., and F. G. Barrows, of Fergus Falls, Minn. It is understood that the Company will rebuild, as they own about 400,000,000 feet of standing timber in the vicinity.

—The saw mill which J. S. Emerson is erecting at Greenway Sound, B.C., is rapidly nearing completion. Mr. Emerson has covered a wide area in his machinery purchases. The Vancouver Engineering Works supplied the boiler, belting, shafting, and several other parts. Circular slashing down saws will be used. Mr. Emerson proposes later on to establish a planing mill in Vancouver, in connection with the Greenway Sound mill.

MUCH PLEASED.

Mr. M. Vance, James Bay Junction, Ont., writes: "I am much pleased with THE LUMBERMAN."

As a result of tests with concrete ties, the Lake Shore Railway has found them to be a failure, it is reported, and no more will be used. The concrete will not last nearly as long as wooden ties, it is claimed. They chip off at the edges until nothing but the iron stay in the interior remains.

RAILS and TRACK SUPPLIES

NEW and Re-Laying from 12 to 60 lbs. per yard with fastenings; for Lumbering, Mining and Contracting Work. Immediate shipment from Stock. Get our prices before purchasing.

SESSENWEIN BROS.,

101 Shannon Street, Montreal

CONSULT YOUR FILER . . .



Hanchett Circular Saw Swage

about that new swage or swage shaper you are going to buy, and if he has never used our tools just drop us a line and we will gladly send free for 30 days' trial one of our

HANCHETT ADJUSTABLE SAW SWAGES OR SWAGE SHAPERS

The Hanchett Swages have stood the test of years. They are standard make, and a customer who purchases one knows he is getting the best money can buy. Sold with unqualified guarantee.

Send for our new Catalogue "F". It tells all about our Saw Swages and Swage Shapers. Free for the asking.

Manufacturers of complete outfits for the filing room.

HANCHETT SWAGE WORKS, BIG RAPIDS, MICH., U.S.A.

THE HANCHETT AUTOMATIC BAND SAW SHARPENER.

In placing the Hanchett automatic band saw sharpener upon the market, the manufacturers are giving to users of saw mill machinery a very pronounced improvement in this class of saw sharpening machines. It is the product of twenty years practical experience in saw mills and in the construction of machinery for all classes of saw sharpening. Its ability to do superior work has been amply demonstrated in some of the best band mills in the United States. The machine is



THE HANCHETT AUTOMATIC BAND SAW SHARPENER.

compact, solid and strong. The mechanism and material is of the very best, while the finish placed upon these machines is claimed to be far above anything ever placed upon saw sharpening machinery.

The mechanism for the most part is altogether different from any other machine designed for sharpening saws. The machine runs with scarcely any noise or vibration.

It is of vital importance that a saw sharpener in motion should be free from vibration. Otherwise the result is an unevenly ground tooth, thus impairing the quality and quantity of work obtainable from any saw. This is obtainable by two chief modes of construction, both of which will strike the eye of the observer as soon as he sees the machine. Examine the illustration and you will observe that the emery wheel is driven direct from the countershaft by an endless rawhide rope, over two step grooved sheaves. This arrangement does away with all pulleys and brackets, effectually preventing vibration. The feed is run by a friction and disk and is consequently noiseless. The manufacturers have a patent friction which is so adhesive that the whole machine may be stopped before it will slip.

A card to the manufacturers, The Hanchett Swage Works, Big Rapids, Mich., will secure full information on this superior machine.

A SUCCESSFUL BUSINESS.

It is now just six months since the Manitoba Gypsum Company put their first advertisement in the CANADA LUMBERMAN and only four months since they brought down their first cargo of hard wall plaster. In the meantime they have had to face all kinds of competition. Their powerful rivals from the United States, backed up by large capital and with the prestige of an old established business, met them with derision as a small local concern that would soon be snuffed out for want of capital and experience. The reputation of goods made by a defunct company, which were not as good as they might have been, handicapped them probably more than the American competition.

But in spite of all, quality tells in the long run; and to-day the Manitoba Gypsum Company has the satisfaction of seeing great rents made in the wall of its opposition and the prospect of an early control of the plaster business of Western Canada.

The testimonials received by the Company from all quarters, especially from many who were at first utterly opposed to their goods, is an eloquent argument in favor of their products; the many fine business blocks and handsome residences finished with their hard wall or wood fibre plaster will long be silent evidence of the permanency of their material.

We understand that the company contemplate an early addition to their plant and propose further enlarging the line of their products by the manufacture of Plaster Slab, the latest form of lath used in modern building. As they now have a yearly capacity of twenty thousand tons, it will be seen how rapidly this business is developing.

NEW DOCK AT MANCHESTER, ENG.

No time has been lost by the Manchester Ship Canal Company in bringing into practical use the new dock which was so successfully opened by Their Majesties the King and Queen on Thursday, July 13th, and to the steamer "Egholm" has fallen the honour of being the first vessel to discharge in Dock No. 9.

This steamer is from Rafso in the Baltic, with 620 standards on account of H. Newsom, Sons & Company, Ltd., the agents for the steamer being Messrs. Herbert Watson & Company.

The steamer "Winnie" ran the "Egho'm" very closely as the pioneer steamer to enter the new dock. She arrived with a large cargo of spruce from Miramichi, on account of the well known firm of Messrs. Harrison, Robinson & Company, who have been consistent supporters of the canal from the outset, and head the list of timber importers.

The timber season is now in full swing, and everything points to Manchester beating her previous timber record, viz., 353,280 tons imported last year. In fact, up to the present time, the import of timber to Manchester exceeds by about 20,000 tons the quantity arrived during the same period last year.

In order to maintain the splendid reputation the port

has obtained, both with shipowners and merchants, for the handling of timber cargoes, it is essential that prompt discharge should be given to vessels after arrival, and that adequate space should be afforded on the open quays for the rapid handling of the traffic, including sorting, measuring, and delivery to railway waggons, carts, and storage ground. The large area of quay space, with a frontage of 2,700 feet on the north side of Dock No. 9, is specially welcome to the Canal Company at this period, and before many weeks have elapsed a large quantity of timber will be located there.

The visit of the King and Queen on August 13th marked an event as important as the opening of the Canal itself—the inauguration of the new (No. 9) dock—signifying that the Manchester Ship Canal Company has turned out a great success, and that its expansion has outgrown the already large facilities it has for the docking of ships and the storage of goods.

Mr. R. Dawson Harling, Canadian representative of the Manchester Ship Canal Company, whose address is 28 Wellington Street East, Toronto, will be pleased to answer any inquiries with reference to the lumber export trade to Manchester.

SHINGLE SAW SET GAUGE.

The cut herewith illustrates the new shingle saw set gauge just placed on the market by Messrs. E. C. Atkins & Company, Inc., Indianapolis, Ind. This



ATKINS SHINGLE SAW SET GAUGE.

tool is claimed to be the most desirable and satisfactory ever made for the purpose of gauging the set of teeth in shingle, heading and cylinder saws, and its utility will be immediately recognized by mill men everywhere. It can be quickly adjusted to any degree or pitch desired and insures a uniform set throughout the saw. It is nickel plated, very nicely finished and very inexpensive, the selling price being only 75c. each.

The JOHN McDUGALL CALEDONIAN IRON WORKS CO., Limited
MONTREAL, QUE.

BOILERS, TANKS, FILTERS,
MILL MACHINERY, Etc.

Builders in Canada of the Celebrated

"WORTHINGTON" TURBINE PUMPS

AND

"DOBLE" TANGENTIAL WATER WHEELS

General Agents in Canada for the INTERNATIONAL STEAM PUMP CO. and its Companies.

Catalogues on Application



THE CAMPBELL LUMBER COMPANY.

The Campbell Lumber Company, Limited, a short time ago purchased the property at Weymouth Bridge, N.S., owned by the Sissiboo Pulp & Paper Company, Limited. Although originally intending to exploit the lumber business only, they have manufactured considerable pulp, which we understand has given great satisfaction to the trade owing to its superior quality and texture. They have experimented with the manufacture of pulp from edgings and slabs which were formerly

put into the furnace and find that the very best quality of pulp is produced therefrom.

The Sissiboo property, with the former Campbell freehold acreage, gives the company about 40,000 acres of spruce lands and practical control in the Sissiboo lakes and waters, including eleven dams and water powers, controlling flowages for probably 100 square surface miles as reserve waters for driving logs and grinding pulp. This year they are manufacturing between eight and ten million feet of

lumber and expect to handle a much increased output during the coming year, including a few thousand tons of pulp. They also manufacture laths, shingles and box shooks, and make a specialty of South American cargoes.

Mr. McVicar intends building a saw mill here, the town having given some assistance.

William F. Lawrence & Sons, lumber dealers, Sarnia, Ont., have commenced the erection of a new planing mill, to be 80 x 175 feet and equipped with modern machinery.

P. H. WRIGHT
43 Bank Street, OTTAWA
Lumbermen's Agent
All kinds of Mill and Bush help secured on short notice
Telephone 2586

H. J. FRIEL
EMPLOYMENT AND LUMBERMEN'S AGENT
Bushmen supplied on short notice, also mill hands. Hotel help of all kinds procured.
Office: 73 BANK STREET
Phone 721 OTTAWA

THE NEW
Dominion Saw Gummer
Saw Gummer Cutters of all Descriptions
MANUFACTURED BY
A. T. McLATCHIE, Cardinal, Ont.

YOU WHO MAKE PICKETS



Can point over 5,000 a day with our famous **PORTLAND PICKET POINTER**. Gives any style of Gothic point desired; works easily, quickly, **perfectly**; will prove a big money earner for any lumber concern. Ask for illustrated booklet.

ADDE & CO.,
109 Kennebec Street,
-- PORTLAND, MAINE --

OILS
Manufacturers High-grade Cylinder, Machine and Sawmill Oils.
Calypsol Grease
for Sawmill Purposes a Specialty. Our products are made from finest Pennsylvania stocks.
We solicit your correspondence.
St. John St., MONTREAL.
Offices and Works: Manchester, Eng. Hamburg, Germany. Newark, N. J. Chicago, Ill.
Commercial Oil Co.,
Hamilton, Ont.

CANDY'S
REGISTERED TRADE MARK
AMERICAN COTTON BELTING
GUARANTEED.
Sole Canadian Agents - Prices Reduced
WATEROUS, BRANTFORD, CANADA

PAT. OSCILLATING BOB SLED KNEE
Hauls 25 per cent. easier, and wears longer, and is lighter than all others.
THOMPSON MFG. CO., Ltd.,
Grand Bay, N. B.
C. H. VOGEL
A. M. Can. Soc. C.E. OTTAWA, CAN. ENGINEER
Surveys, Plans, Specifications and Supervision
WATER POWER
Paper, Pulp and Sulphite Fibre Mills

THE E. L. PURVIS CO.,
18 COLBORNE ST., TORONTO, ONT.

PIPE AND BOILER COVERINGS
Asbestos Mineral Wool and all kinds of Fireproofing
Material Agents for
FAMOUS MICA COVERINGS

MAPLE LEAF
STITCHED COTTON DUCK
BELTING
DOMINION BELTING CO. LTD.
HAMILTON CANADA

WOODWORKERS SAY
"The convenience to the Sawyer and the saving in lumber make the **STANDARD AUTOMATIC SAW GAUGE** an article of much merit."
WRITE TO **SPECIALTY MFG. CO.**
DETROIT Mich.

PAROID ROOFING

FOR THE

PANAMA CANAL

The first proposals issued by the Isthmian Canal Commission called for Paroid Roofing, or equal, and the order was placed with us.

The U. S. Government again recognizes the standard qualities of Paroid, having used many carloads in this country, Cuba and the Philippines.

If you believe in quality, get our samples and booklet.

F. W. BIRD & SON, MAKERS,

HAMILTON, ONT.

Established in U. S. A. in 1817.

FORESTRY DEPARTMENT

ANNOUNCEMENT OF FORESTRY CONVENTION.

OFFICE OF THE PRIME MINISTER OF CANADA,
OTTAWA, 21ST August, 1905.

TO THE PUBLIC OF THE DOMINION OF CANADA:

Canada possesses one of the largest areas of virgin forest of any country in the world and is ranked by European experts first, or among the first of the important sources of the world's timber supply for the future.

The preservation of the streams in perennial and constant flow, which is largely controlled by the forests on the watersheds, will have an important influence on the industrial and agricultural development of the Dominion. The expansion of our electrical and mechanical industries will be regulated to a great extent by water, which forms the greatest source of power in all countries, and some of our western districts are dependent on irrigation to ensure the success of agricultural operations.

In all the older provinces the clearing of the soil has been carried to such an extent that the ill effects on the water supply and on agriculture are clearly marked, while on the western prairies the need of sheltering trees for houses and fields is seriously felt by the settlers.

The early construction of the Transcontinental Railway, and of other railways, through our northern forested districts and the consequent opening of those districts to general traffic, will increase the danger from fire, which has already been a most active agent of destruction.

These conditions are not new; they have from time to time received public attention, and during the Session just closed Parliament authorized the summoning of a convention for the more thorough discussion of the same.

I therefore hereby call a public convention to meet in the City of Ottawa on the 10th, 11th, 12th of January, 1906, under the auspices of the Canadian Forestry Association, and to this convention are specially invited:

Members of the Senate and House of Commons.

Lieutenant-Governors of the Provinces.

Members of Legislative Councils and Legislative Assemblies of the Provinces.

Dominion and Provincial Forest Officials.

Members of the Canadian Forestry Association.

Representatives of Lumbermen's Associations.

Representatives of Boards of Trade.

Representatives of Universities.

Representatives of Agricultural Colleges.

Representatives of Farmers' Institutes.

Representatives of Railway Companies.

Representatives of the Canadian Mining Institute.

Representatives of the Canadian Society of Civil Engineers.

Representatives of Associations of Land Surveyors.

Representatives of Fish and Game Associations, and all others who take an interest in Forestry.

An invitation is also extended to the Bureau of Forestry of the United States, the American

Forestry Association and the State Forestry Bureaus and Associations to send representatives to this Convention.

WILFRID LAURIER.

CANADIAN FORESTRY CONVENTION.

In accordance with the official summons issued by the Right Honourable the Premier of the Dominion, arrangements have been made for a Canadian Forestry Convention to be held in Ottawa on the 10th, 11th and 12th of January next, to consider the forests of the Dominion and their national importance.

This Convention is held under the auspices of the Canadian Forestry Association and the organization and carrying out of the project has been placed in the hands of the Association.

The subjects to be considered at the Convention will be discussed under the following divisions:—

1. The Nation and the Forest.
2. Forestry in Relation to Agriculture and Irrigation.
3. The Forest and the Lumber and Pulp Industries.
4. The Relation of our Forests to our other Industries: Railways; Water Powers; Mining; Building Trades; Wood Working Manufactures.
5. Scientific Forestry and Forestry Education.

By the kindness of the Canadian Railway Companies a single fare rate over their roads on the certificate plan will probably be allowed delegates, regardless of the number in attendance. In regard to rates on railways in the United States, announcement will be made later.

For further particulars application may be made to the Secretary of the Convention, Mr. R. H. Campbell, Department of Interior, Ottawa.

The officers and executive committee are as follows:

Honorary President, His Excellency the Governor General.

President, Right Honourable Sir Wilfrid Laurier.

Vice Presidents, His Honour Sir Henri Joly de Lotbiniere, R. L. Borden, M.P.

EXECUTIVE COMMITTEE:

His Honour J. B. Snowball, Lieut-Governor of New Brunswick.

His Honour Sir D. H. McMillan, Lieut-Governor of Manitoba.

His Honour A. E. Forget, Lieut-Governor of Saskatchewan.

Hon. Sydney Fisher, Minister of Agriculture for Canada.

Hon. W. C. Edwards, President Quebec Limit Holders' Association.

J. B. Miller, President Ontario Lumbermen's Association.

Chas. M. Hays, General Manager Grand Trunk Railway.

Hon. S. N. Parent, Chairman Transcontinental Railway Commission.

Hon. Nelson Monteith, Minister of Agriculture for Ontario.

Hiram Robinson, President Hawkesbury Lumber Company.

Hon. J. H. Agnew, Commissioner of Lands for Ontario.

Hon. F. J. Sweeney, Surveyor General of New Brunswick.

John Hendry, President B. C. Lumber and Shingle Manufacturers' Association.

Rev. A. E. Burke, Vice-President Canadian Forestry Association, Alberton, P.E.I.

H. M. Price, President Quebec Pulpwood Association.

Dr. Robert Bell, Director of the Geological Survey of Canada.

Thos. Southworth, Director of Forestry for Ontario.

M. J. Butler, C.E., Deputy Minister of Railways and Canals.

Cecil B. Smith, C.E., Chairman Temiskaming and Northern Ontario Railway Commission.

Dr. Judson F. Clark, Forester for the Province of Ontario.

Aubrey White, Hon. President Canadian Forestry Association.

E. G. Joly de Lotbiniere, President Canadian Forestry Association.

E. Stewart, Dominion Superintendent of Forestry.

Wm. Little, Westmount, P.Q.

Hon. H. Bostock, Vice-President of the Canadian Forestry Association.

D. McNicol, General Manager Canadian Pacific Railway.

Hon. A. E. Turgeon, Commissioner of Lands and Forests, Quebec.

Hon. R. F. Green, Chief Commissioner of Lands and Works for British Columbia.

Hon. Arthur Drysdale, Commissioner of Crown Lands for Nova Scotia.

J. R. Booth, Ottawa.

Hon. A. B. Warburton, Charlottetown, P. E.I.

B. E. Walker, General Manager Bank of Commerce.

F. W. Jones, President B. C. Mountain Lumbermen's Association.

J. L. Campbell, President Western Retail Lumbermen's Association, Melita, Man.

Wm. Saunders, L.L.D., Director of Dominion Experimental Farms.

J. S. Dennis, Director of Irrigation for the Canadian Pacific Railway Company.

Monsignor J. U. K. Laflamme, University of Laval.

F. C. Whitman, President Western Nova Scotia Lumbermen's Association.

Wm. Pearce, Vice-President Canadian Forestry Association, Calgary, Alberta.

Norman M. Ross, Assistant Superintendent of Forestry for Canada.

F. D. Wilson, Vice-President of the Canadian Forestry Association, Fort Vermilion, Alberta.

Secretary, R. H. Campbell, Secretary of the Canadian Forestry Association, Department of the Interior, Ottawa.

An English subscriber writes that the sawn stock received in his country from the United States and Canada is not to be compared to Swedish and Russian stock for quality of sawing and measurements as to standard sizes. He admires our ability to turn out great quantities of wood, but thinks we should take greater care in execution.

FINANCIAL STATEMENTS OF THREE LUMBER INSURANCE COMPANIES

Noteworthy Features of these Statements are

ASSETS: No Contingent Items.
All Cash or the Equivalent.

LIABILITIES: Slight Actual Liabilities.
Principal Items Capital and Reinsurance Reserve.

LUMBER INSURANCE COMPANY OF NEW YORK.

66 BROADWAY, NEW YORK.

ORGANIZED 1904.

PENDENNIS WHITE, President
S. M. CLEMENT, Buffalo, N. Y.
WILLIAM HAMLIN, Buffalo, N. Y.
JOHN G. LARKIN, Buffalo, N. Y.
HUGH McLEAN, Buffalo, N. Y.
HENRY J. PIERCE, Buffalo, N. Y.
HORACE F. TAYLOR, Buffalo, N. Y.

HORACE F. TAYLOR, Vice-President
LEWIS OILL, Baltimore, Md.
W. A. HOLT, Orono, Wis.
FREDERICK W. MATTOCKS, New York City
GEORGE A. MITCHELL, Buffalo, N. Y.
C. H. PRESKOTT, Jr., Cleveland, Ohio
PENDENNIS WHITE, Buffalo, N. Y.

R. H. McKELVEY, Secretary
WILLIAM H. GRATWICK, Buffalo, N. Y.
W. C. LAIDLAW, Toronto, Ont.
JOHN JAY McKELVEY, New York City
E. F. PERRY, New York City
FRANK C. RICE, Springfield, Mass.

STATEMENT JULY 1st, 1905.

ASSETS		LIABILITIES	
Cash in Banks.....	\$154,014.14	Capital Stock.....	\$200,000.00
Bonds.....	200,430.00	Reinsurance Reserve.....	54,578.40
Accrued Interest.....	2,812.62	Losses in process of adjustment.....	4,087.02
Due from Reinsuring Companies.....	1,121.49	Surplus.....	123,671.24
Premiums in process of Collection.....	24,158.41		
	382,536.66		382,536.66
Net Insurance in force.....		\$5,591,305.03	
Premiums in Force.....		109,156.80	
Losses Paid since organization.....		48,348.86	

TOLEDO FIRE AND MARINE INSURANCE CO.

SANDUSKY, OHIO

Organized 1848. As a Lumber Insurance Company 1902

EXECUTIVE COMMITTEE.

J. J. McKELVEY EUGENE F. PERRY FREDERICK W. MATTOCKS

AUGUST 1st, 1905

ASSETS		LIABILITIES	
Cash in Banks.....	\$101,617.61	Capital Stock.....	\$100,000.00
Sandusky City Bonds.....	40,497.80	Reinsurance Reserve.....	46,293.69
Accrued Interest.....	1,072.68	Losses in process of adjustment.....	2,503.81
Due from other Companies.....	1,271.01	Net Cash Surplus.....	20,493.72
Agents Balances and Premiums in Process of Collection.....	24,832.12		
	\$169,291.22		\$169,291.22
Net Insurance in Force.....		\$4,251,484.11	
Premiums in Force.....		92,587.39	
Losses paid since Re-organization.....		83,204.90	

Rates Consistent with the Hazard.
Direct Applications Solicited.

LUMBER INSURERS GENERAL AGENCY MANAGERS

66 Broadway, NEW YORK

SANDUSKY, OHIO

LUMBER UNDERWRITERS

66 BROADWAY, NEW YORK

Organized 1892. As a Lumber Insurance Company 1900

ATTORNEY, FREDERICK W. MATTOCKS

ADVISORY COMMITTEE

PENDENNIS WHITE EUGENE F. PERRY JOHN JAY McKELVEY

UNDERWRITERS

CHAS. M. BETTS, Philadelphia
FREDX. W. COLE, New York
C. H. CARLETON, Cleveland, Ohio
LEWIS OILL, Baltimore, Md.
W. A. HOLT, Orono, Wis.
M. S. TREMAINE, Buffalo, N. Y.

W. C. LAIDLAW, Toronto, Ontario
H. SHUNWAY LEE, Buffalo, N. Y.
ROBERT C. LIPPINCOTT, Philadelphia
JOHN JAY McKELVEY, New York
ANGUS McLEAN, Buffalo, N. Y.
PENDENNIS WHITE, North Tonawanda, N. Y.

FREDERICK W. MATTOCKS, New York
EUGENE F. PERRY, New York
C. H. PRESKOTT, Jr., Cleveland, Ohio
FRANK C. RICE, Springfield, Mass.
HORACE F. TAYLOR, Buffalo, N. Y.

STATEMENT JULY 1st, 1905

ASSETS		LIABILITIES	
Cash in Banks.....	\$94,827.06	Reinsurance Premiums Payable.....	\$ 5,153.42
Agents Balances and Premiums in Process of Collection.....	34,105.60	Losses in Process of Adjustment.....	292.35
Investment Loans.....	17,500.00	Reserve for Reinsurance.....	60,580.76
Due from Reinsuring Companies.....	6,599.87	Management Expense.....	5,673.67
	\$152,942.53	Net Surplus.....	81,242.33
			\$152,942.53
Net Insurance in Force.....		\$6,072,065.57	
Premiums in Force.....		121,161.52	
Losses Paid since Organization.....		174,442.85	

CHICAGO'S LUMBER CONSUMPTION.

In a recent issue of the American Lumberman is found the tabulated statement of the lumber receipts and shipments for Chicago during the first six months of 1905. The total receipts were 958,457,000 feet, all of which were brought in by rail excepting 132,454,000 feet by lake. The total shipments for the same period were 458,299,000 feet or less than one-half the receipts. This indicates a local consumption of more than 1,000,000,000 feet annually. The volume of business is greater than any six months since 1900 excepting in 1902, when the first half year's receipts and shipments were in excess. The receipts of shingles in 1905 were 280,600,000, with shipments of 219,087,000. This shows a local consumption of only 123,000,000 a year. It is quite evident from these figures that shingle makers must look for their customers outside of large cities.

SETTLERS LOW RATE WEST.

The Chicago and North Western Railway will sell low one way second class settlers tickets, daily from Sep. 15th to Oct. 31st, 1905, to points in Utah, Montana, Nevada, Idaho, Oregon, Washington, California and British Columbia. Rate from Toronto to Vancouver, Victoria, New Westminster, B. C., Seattle, Wash., or Portland, Ore., \$42.25; to San Francisco or Los Angeles, Cal., \$44.00. Correspondingly low rates. Best of Service. For full particulars and folders write to B. H. Bennett, General Agent, 2 East King St., Toronto, Ont.

P. PAYETTE & CO.

Manufacturers of Saw Mill and Engine Machinery and all kinds of Marine Machinery.
PENETANGHISHENF, ONT.

THE LUMBER ANTI-STAIN COMPANY

Head Office, WILMINGTON, DELAWARE

To the Lumber Trade of Canada:

We hereby give notice that two infringement suits have been filed in the Circuit Court of the United States for the Western District of Michigan, Northern Division, for the infringement of our patent No. 746,678, dated December 15, 1903, relating to the treatment of lumber for the prevention of sap staining, and we warn others that infringements of our rights will be vigorously prosecuted. Rights to use this valuable process may only be obtained by applying to

Robert H. Munson, President,
Lumber Anti-Stain Company.

Sault Ste. Marie, Mich.

Our Canadian patent is number 91936.

TRANSMISSION ROPE

We are the largest Manufacturers of **TRANSMISSION ROPE** in Canada. Our mills are equipped with special machinery for manufacturing extra long lengths. We import the most select Brands of Manila Fibre, and are therefore in a position to supply a **FIRST CLASS ROPE**.

Rope Transmission has proved to be the most satisfactory and economical drive.

If you contemplate buying, we would be pleased to have our expert call upon you.

CONSUMERS CORDAGE CO., LIMITED
Montreal and Halifax

The following items appear on our Stock List and are to be cleared out this month. It is all new machinery and will be offered at Figures which represent actual Cost to us.

SAW MILLS

- 535 1-No. 1 Lane Mill R. H. Wood Frame, 16 ft. Carriage, Rope Feed, New.
536 1-No. 0 Lane Mill R. H. Wood Frame, 24 ft. Carriage, Rack and Pinion Feed, New.
537 1-No. 0 Lane Mill R. H. Wood Frame, 25 ft. Carriage, Rack and Pinion Feed, New.
538 1-50 in. Circular Rip Saw, Shurley-Dietrich, New.

SAW MILL EQUIPMENT

- 539 1-2 Saw Trimmer, New.
540 1-Lockport Shingle and Heading Machine, New.
541 1-Double Edger, 3 Saw complete with End Tables, New.

The Manitoba Iron Works Co.
LIMITED

Logan, Henry, Brant and Dorothy Streets,
WINNIPEG, MAN.

THE LUMBER MUTUAL FIRE INSURANCE COMPANY
BOSTON, MASS.

STRENGTH

NET ASSETS, AUGUST 31, 1905
All Liabilities Deducted—Sec. 1—Chap. 188—Mass. Laws.

\$700,839.99

ECONOMY

DIVIDENDS TO POLICY HOLDERS

33 $\frac{1}{3}$ %

MAIL EXPIRING POLICIES WITH YOUR ORDER.

THE LATE ALFRED M. REGAN.

The untimely death of Mr. Alfred M. Regan, which occurred on August 30th just after our September number had gone to press, was a great shock to his many friends in Toronto and elsewhere. Although not in the best of health, he was still giving attention to his business duties. Leaving his office in the McKinnon Building on Melinda street about two o'clock in the afternoon, he had gone but a few yards when he fell on the street and expired within a few minutes.

For the last ten years deceased had been a member of the wholesale lumber firm of Regan & Nickels, being formerly connected with the R. S. Williams Piano Company. Though quiet and unassuming, he had many warm friends. He leaves a wife, but no family. It is understood that the business will be continued by Mr. Nickels as heretofore.

TRADE NOTES.

The Nova Scotia Iron & Steel Company have recently put in two automatic spike machines, manufactured by the Smart-Turner Machine Company, Hamilton, Ont.

The William Hamilton Manufacturing Company, of Peterboro, Ont., are operating to their maximum capacity, having orders in hand for several saw mill plants for British Columbia.

The Vancouver Engineering Works recently shipped a 10x15 road engine to Norton & McKinnon's logging camp and a 9x10 yarding engine to Vanstone & Hughes, of Okio Hollow, B.C.

The Hamilton Bridge Company have recently ordered from the Smart-Turner Machine Company, Limited, of Hamilton, two Standard duplex pumps for construction work.

The B. C. Mills, Timber & Trading Company have purchased another S. A. Woods planer and matcher from the Canadian Fairbanks Company for their Royal City Mills branch at Vancouver.

The Alexander Dunbar & Sons Company, Limited, has been incorporated, with a capital of \$75,000, to acquire the business of Alexander Dunbar & Son,

manufacturers of saw mill machinery, etc., Woodstock, N.B.

Campbell Bros., of St. John, N. B., report that they are finding a very large demand for their XXX brand of chopping axes, their business of this year being considerably in excess of that of last year.

The Robb Engineering Co., Amherst, N.S., have recently ordered from the Smart-Turner Machine Company, of Hamilton, one of their independent air pumps and jet condensers, also a Duplex boiler feed pump.

A license has been granted to E. C. Atkins & Company, of Indianapolis, Ind., to transact business in Ontario as manufacturers of saws, tools, etc. Mr. C. D. Ten Eyck, of Toronto, has been named as their attorney.

The business of John Bertram & Sons, Dundas, Ont., has been amalgamated with several large concerns in the United States, and under the new arrangement new buildings will be erected and a general policy of expansion inaugurated.

The International Harvester Company have placed an order for a centrifugal pump with the Smart-Turner Machine Company, Limited, of Hamilton. This is the sixth Smart-Turner pump the International Harvester Company have installed in their works.

The Vancouver branch of the Canadian Fairbanks Company has been removed to their new building at the corner of Water and Abbott streets. Besides the spacious offices, the company have extra large warehouse accommodation and their own side-track facilities at the rear.

The James Robertson Company, Limited, of Montreal, has been incorporated by J. M. H. Robertson, Charles M. Robertson, A. A. McMichael, James Robertson and Alex. Robertson. The object of the company is to acquire the business now carried on by the James Robertson Company at St. John, N.B.

The Canadian Fairbanks Company have installed an S. A. Woods planer in the Vancouver Lumber Company's new planing mill. All the belting used in this mill is the Fairbanks "Perfection" brand. The Fairbanks Company have also secured the contract to supply the main drive belt for this mill, which will be 48 inches wide by 8 ply thick and of their "F" brand.

The A. J. Burton Saw Company, of Vancouver, B.C.,

are in receipt of a letter from B. A. Hansen & Company, of Wellington, New Zealand, asking for quotations for supplying the necessary machinery for a new planing mill they are erecting. The letter mentions the CANADA LUMBERMAN as the medium through which Messrs. Hansen discovered the existence of the Burton Company. This is the second inquiry within recent date they have had from the Antipodes, the other coming from Australia. "It pays to advertise."

*You haven't time now to build and equip a **SAW MILL** but here is a new, smart, perfectly equipped, modern band saw mill plant that is for sale at a bargain. Located on both rail and tide-water, it can be taken down entire, including buildings, and moved promptly to any place you may want it.*



*Everything is here complete, assembled by experts in the business, and you are spared the time and worry of planning, buying, and collecting all this machinery and material. For particulars address **SAW MILL E, Box 775, New York City.***

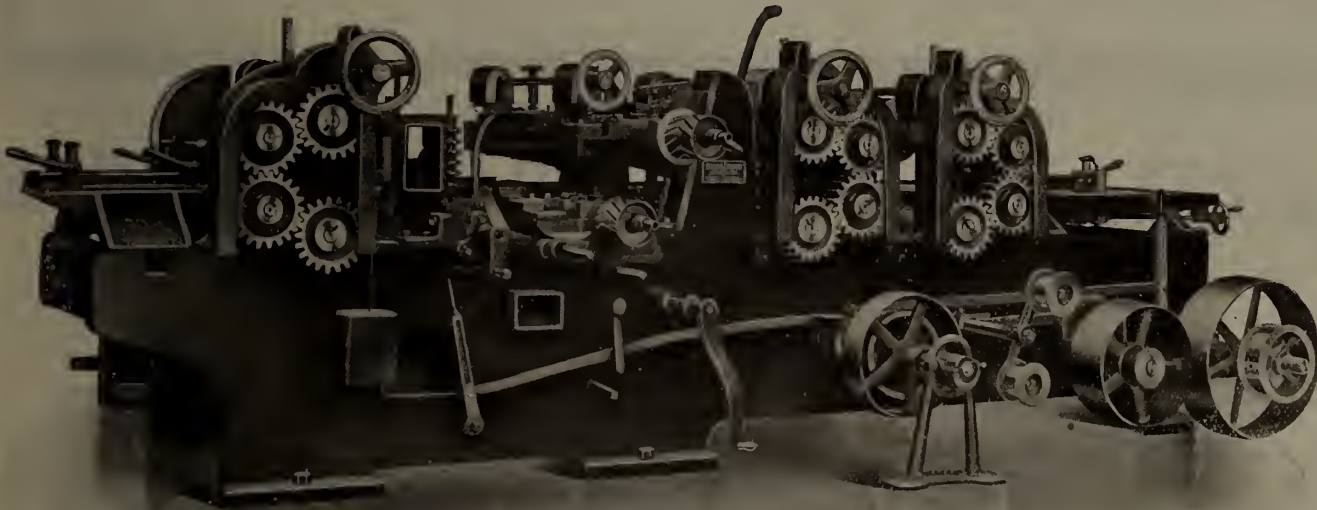

PLANER AND MATCHER

M 169

Made in several sizes; all fitted with wedge platen for instantly adjusting, regulating and distributing the cut between the cylinders; the greatest labor saver embodied in planing mill machinery. We manufacture a full line of wood working machinery. Write for prices and particulars.

COWAN & COMPANY

OF GALT, LIMITED
GALT, - CANADA

Rodgers Iron Mfg. Co.
MUSKEGON, MICH.

Write to us and we will tell you all about it. Read what they say—hundreds more like them.

Rodgers Iron Mfg. Co., Muskegon, Mich. Tomahawk, Wis., March 3, 1905.

Gentlemen: Your favor of February 24th is received; as we have just ordered another of your 72 inch Combination Edgers with inch and two inch gangs on them, should think this would be conclusive evidence of our satisfaction with your machines, as we already have three of them in operation.
Yours truly,

Rodgers Iron Mfg. Co., Muskegon, Michigan. West Monroe, La., Oct. 13, 1904.

Gentlemen: We beg to hand you herewith, check to cover one edger and fixtures as per your invoice of July 15th. We are very well pleased with the machine and the work it is doing.
Yours truly,



COMBINATION GANG EDGER WITH RIFT FLOORING ATTACHMENT

THE DYMENT FOUNDRY COMPANY

BARRIE, ONTARIO

Manufacturers of

Engines, Boilers Steam Feeds . . .

AND A COMPLETE LINE OF

Saw, Shingle and Lath Mill Machinery

Can ship mills in a week's notice. Write us for prices and Catalogue.

GANG LATH and PICKET MACHINE

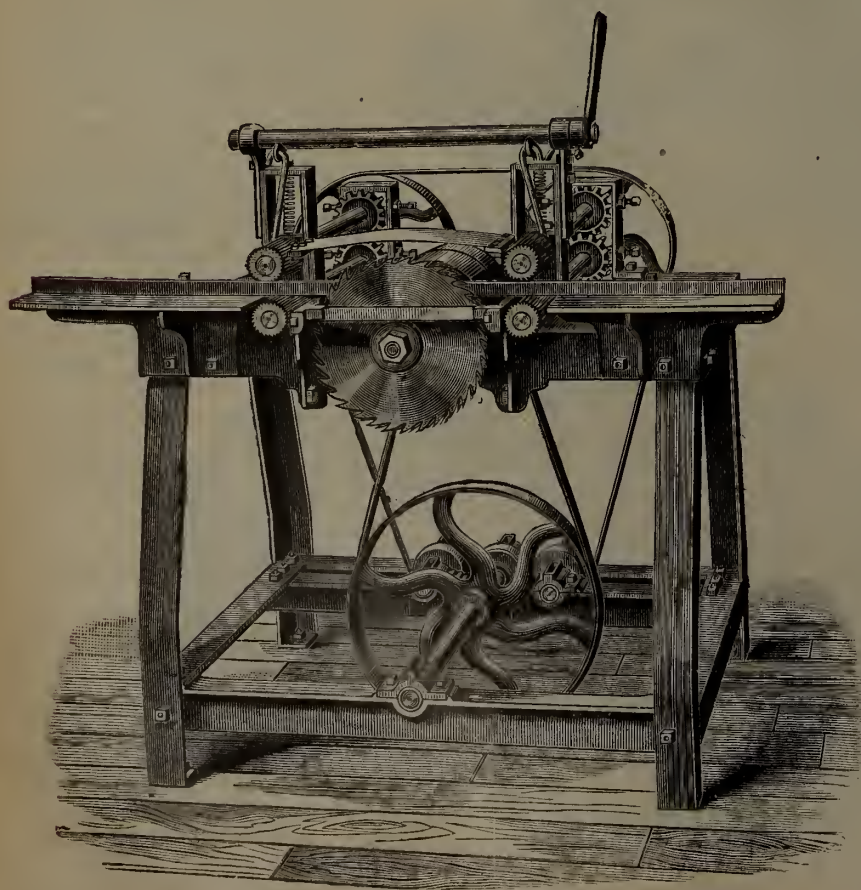

There is no better machine made for the price asked. It has a solid iron frame, which with the saw arbor bearings is cast in one piece. The drive pulley is 8 in. and 9 in. face. Turned inside and out, and very finely balanced. The feed and press rolls are milled out of solid steel and tempered hard. It carries four 12 in. saws, and is adapted for both Lath and Pickets. With the Lath Bolter, its companion, it is capable of turning out a larger amount of work every day, probably more than any other medium price machine on the market.

I have one of these machines in stock now, very little used, and guaranteed in perfect order. Will sell cheap.

Send for Catalogue of Saw Mill, Lath Mill and Shingle and Heading Mill Machinery.

F. J. DRAKE, - - Belleville, Ont.

SHERMAN'S FLOORING MACHINES PATENTED

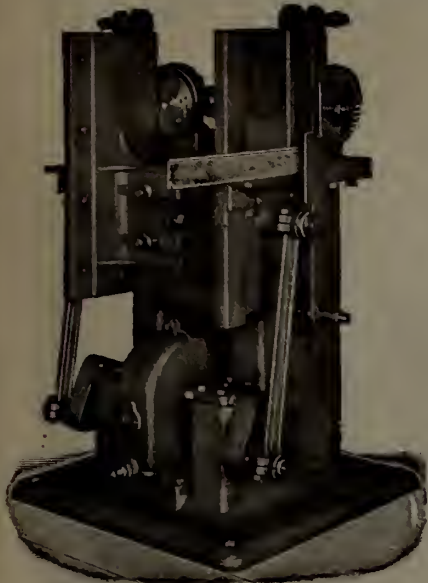

Above cut shows our End Matcher, the best machine in the market for end matching flooring strips. They do rapid and accurate work, and are durable—therefore used by leading flooring manufacturers. Make your flooring profitable by end matching it.

We Make the

SHERMAN SIDE BORING MACHINES
and the
SHERMAN FACE BORING MACHINES

To bore flooring while it is being run on the flooring machine. Write for circular and list of users

W. S. SHERMAN CO.
1150 Holton St., Milwaukee, Wis.

Reliable Veterinary Remedies

No logging outfit is complete without a supply of reliable veterinary remedies. Getting the wrong kind means the loss of the use of your horses when time is valuable.

Johnson's Veterinary Remedies are guaranteed never to fail when used as directed. You get your money back if they ever do.

They are

Johnson's Horse Liniment No. 1.
A penetrating Alcoholic Liniment. Put up in one gallon jugs, with full directions, per imperial gal. \$4.50

Johnson's Horse Liniment No. 2.
A combination of the best oils used as liniments, imp. gallon . \$3.00

Johnson's Horse Colic Remedy.
A sure and speedy cure for colic Imperial gallon \$5.00

Johnson's Veterinary Healing Ointment.

Positively the best all-round healing ointment made. In use by the largest owners of horse flesh in Canada. Put up in 2 lb tins, each . . . \$2.00 or in ¼ lb tins, per dozen . . \$3.00

Johnson's Condition Powders. (Concentrated).

Put up in bulk, per lb. 3c. These goods being put up in bulk are more economical than others, as cost of bottling, etc., is saved.

CAMP REMEDIES.

In addition to our Veterinary Remedies we make a line of medicines for lumbermen, including a strong, penetrating liniment, healing ointment, cholera cure, liver pills, cough syrup, in fact anything in the form of Camp Drug Supplies. We know that there are no better remedies made than those we offer. There may be others nearly as good, but they lack our guarantee. Satisfaction or money back. A trade discount of 10% allowed off all orders amounting to \$100.

Send postal for printed matter.

A. H. JOHNSON
Wholesale Druggist
Collingwood, Ont.

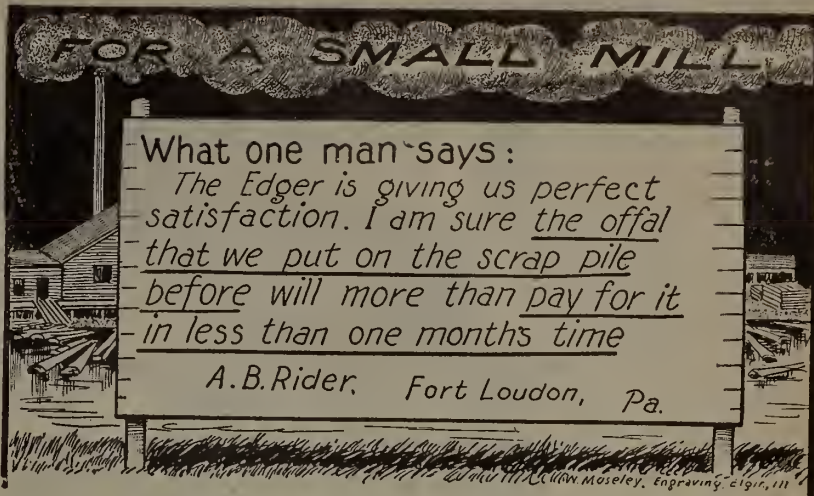

What one man says:
The Edger is giving us perfect satisfaction. I am sure the offal that we put on the scrap pile before will more than pay for it in less than one months time

A. B. Rider, Fort Loudon, Pa.

Do not waste time and lumber by doing your edging on the main saw or with a side edger. The "TOWER" 2 and 3-saw Gang Edgers will edge two or three boards while the main saw or side edger is edging one. Then a "TOWER" Edger wastes no more lumber than is absolutely unavoidable. Again, if you have one of these edgers, your main saw can be kept at work continuously making lumber and cants. Finally, a gang edger alone insures straight and parallel edges. We manufacture thirty different sizes and styles of gang edgers.

THE GORDON HOLLOW BLAST GRATE CO.
THE LARGEST MANUFACTURER OF
BLAST GRATES, EDGERS AND TRIMMERS
IN THE WORLD.
GREENVILLE, MICHIGAN.

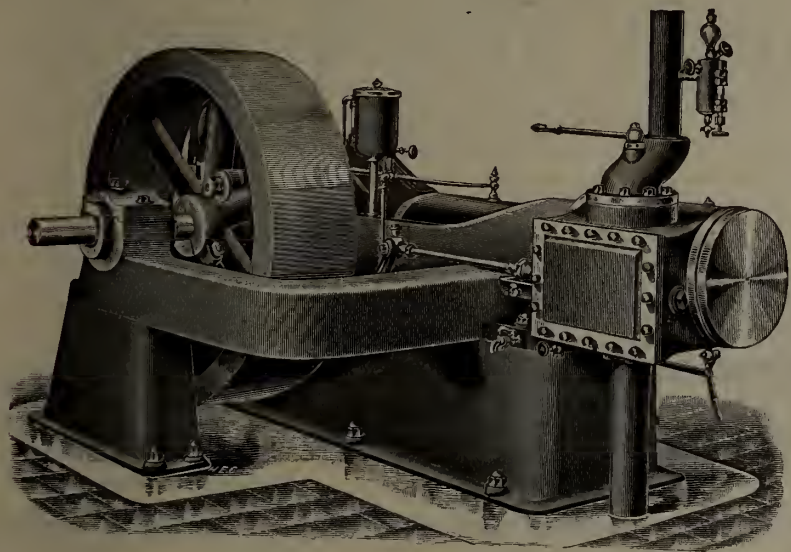

Our Engines are fitted with Automatic Governors and run at Regular Speed, whether Loaded or Light.

They use about 25 Per Cent Less Steam than the best engines with a throttling governor.

They are built on the Interchangeable System so that duplicate parts exact in fit can be supplied at any time.

In Sizes up to 125 Horse Power the outboard bearing is attached to the frame, as shown in the cut, keeping it perfectly in line.

ROBB ENGINEERING CO., LIMITED
Amherst, N.S.

Gonnell & Dengler Machine Co.

ROCHESTER, N. Y.

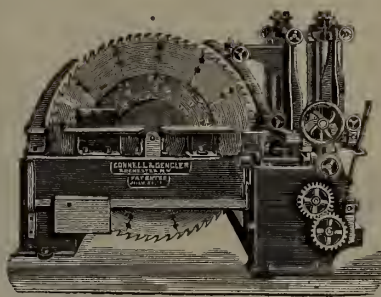

44 Inch Circul. r Re-Saw.

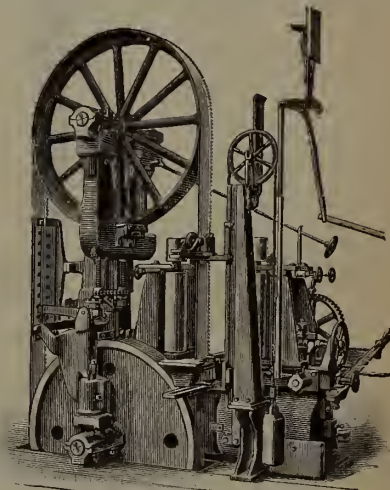

60 inc. Baad Re Saw

Manufacturers of . . .

Box Makers' and Planing Mill Machinery

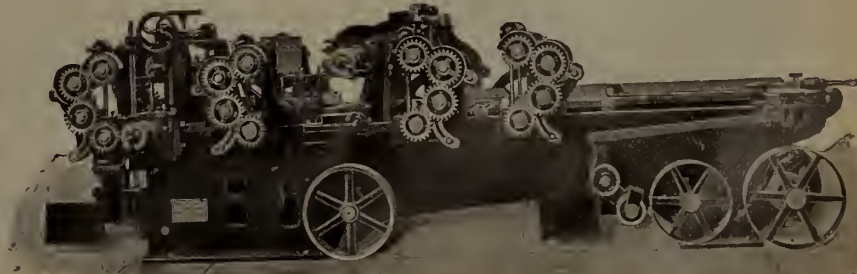

Heavy 26 Inch Divided Roll Planer and Matcher with 8 Feed Roll.

GANT FLIPS - - BOARD FLIPS

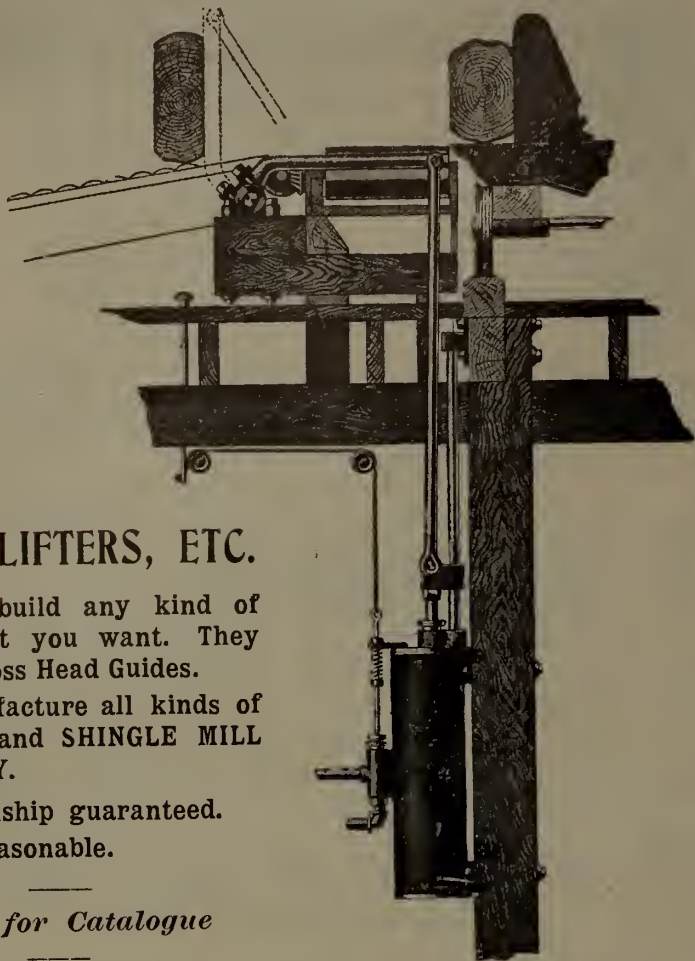

STOCK LIFTERS, ETC.

We can build any kind of a Flip that you want. They all have Cross Head Guides.

We manufacture all kinds of SAW MILL and SHINGLE MILL MACHINERY.

Workmanship guaranteed.
Prices reasonable.

Write for Catalogue

B. R. MOWRY & SONS,
GRAVENHURST, ONT.



Ever
seen
one
of
these
powerful

MCGIFFERT LOG LOADERS

at work, loading or skidding logs, or maybe, switching its own empties? If you haven't you can't fully appreciate the immense amount of heavy work it can do—and at such a saving. It is really wonderful.

Send for catalogue, also booklet of facsimile testimonial letters.

Clyde Iron Works
Duluth, Minnesota, U. S. A.

AT A BARGAIN

- ¶ One 350 Horse Power 16 in. and 28 in. x 36 in. Cross Compound Engine, fitted with Balanced Valves—a strong, durable Engine exactly suited to heavy Saw Mill service.
- ¶ We can finish it up in one week and will sell at a bargain.
- ¶ Full particulars on request.

The JENCKES MACHINE CO., Ltd.
SHERBROOKE, QUE.

ATKINS ALWAYS AHEAD!



QUALITY IS THE THING!

THE MILLMAN'S MILLENIUM

Is not yet here, but the introduction of Atkins Silver Steel Saws has made the day appreciably nearer.

Atkins Saws are as perfect as modern, up-to-date methods, human ingenuity and skill can make them.

They are the most economical Saws to operate because they are tempered just right and will hold a keen cutting edge longer and do 25% more work without filing, will saw true and always make first-class, even lumber, thus being conducive to the operator's peace of mind, happiness and prosperity.

A trial will demonstrate the truth of this statement. Let's hear from you.
Our Sawyer's Hand Book free for the asking.

E. C. ATKINS & CO., Inc.,

Leading Manufacturers of Circular, Band, Cross-Cut, Hand and Wood Saws, Etc.

Factories and Home Office,
Indianapolis, Ind. U.S.A.

Canadian Branch,
56 King St East, Toronto, Ont.



SCRIBNER'S LUMBER AND LOG BOOK

Price 35 Cents.

The CANADA LUMBERMAN, TORONTO

LUMBERMEN

—SHOULD SEE OUR—

PATENT SEAMLESS HEEL LARRIGANS

No chance to rip where it generally does rip in the ordinary make. Also our

PATENT LEGGING

The only legging where the bell front is held down close to the foot so that it can't turn up

—BOTH MANUFACTURED BY—

THE R. M. BEAL LEATHER CO. LIMITED. LINDSAY, ONT.

Write Us

Dundas Lumberman



A New Axe tempered by a new process which enables us to submit to any lumberman three or more samples of Axes, all different degrees of hardness, and on a selection being made we will guarantee to furnish any number all exactly the same temper as sample chosen.

THE DUNDAS AXE WORKS Dundas, Ont.

NEW SEASON'S CURING

LONG CLEAR BACON

SHORT CUT PORK - SAUSAGE, MEATS, &c.

High Grade Quality Write us for Quotations

THE PARK BLACKWELL CO., LTD. PORK AND BEEF PACKERS TORONTO

Don't Hurry---Just Keep Moving

Operators of Shaping Machines—and others who know—will tell you that one-half of their time is devoted to "fitting up" and "getting ready."



OUR "SOLID STEEL SHAPER CUTTERS"

(GUARANTEED)

Are used by manufacturers who by experience know that the "first cost" is very small compared with the "continual cost" when "open heads" are used. OUR CUTTERS are always ready for use, which means "always something doing" on the Shaping Machine.

In ordering—send sample of mould, diameter of spindle, and size of collars.

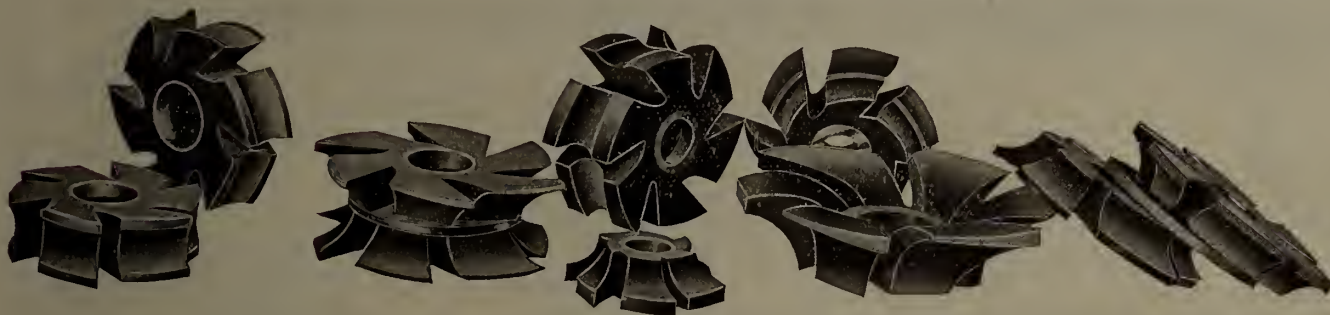

Furniture City Tool Company

189 CAMPAU STREET, GRAND RAPIDS, MICH., U.S.A.

AGENTS—Harron, Rickard & McCone, San Francisco, Cal. Schuchardt & Schutte, Berlin, Germany

Special to Lumbermen, Miners and Railway Contractors



We are Manufacturers of :—Mince Meat, Baking Powder, Coffee, Spices, Flavoring Extracts, Mustards, Tomato Catsup, Worcestershire Sauce, Jams, etc., and all kinds of Grocers' Sundries for Camp Use. Also Sauer Kraut, Pickles and Sausage Meat.

Mince Meat put up in 75 Pound Tubs. 1/2 Barrels about 300 Pounds. Barrels about 600 Pounds. Sauer Kraut and Pickles in Barrels. Sausage Meat in 50 Pound Tins. Sauce and Catsup in 5 Gallon Pails.

ALL GOODS GUARANTEED

Special Attention Given to Mail Orders

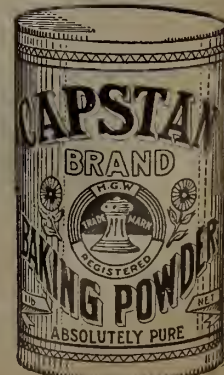

The Capstan Manufacturing Co., TORONTO, ONT., CAN.

WARNOCK TOOLS

Best in the World

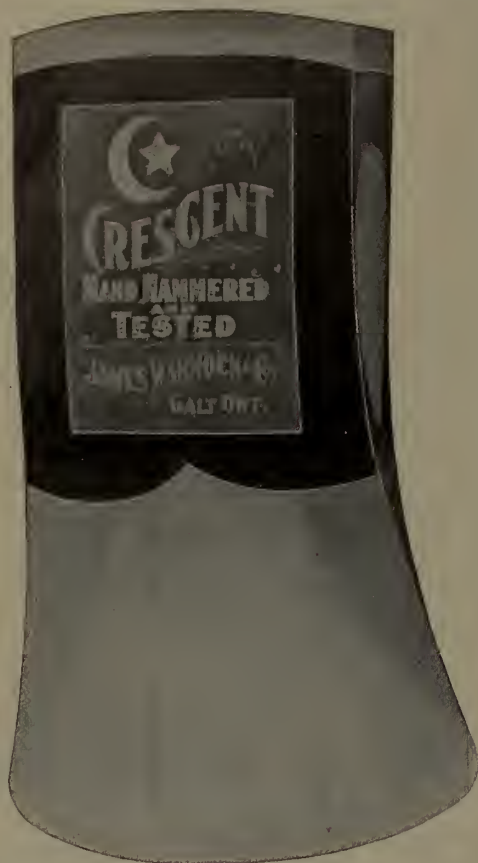

If Strength, Durability, Correct Construction and Lightness are an object, we have the article you are looking for.

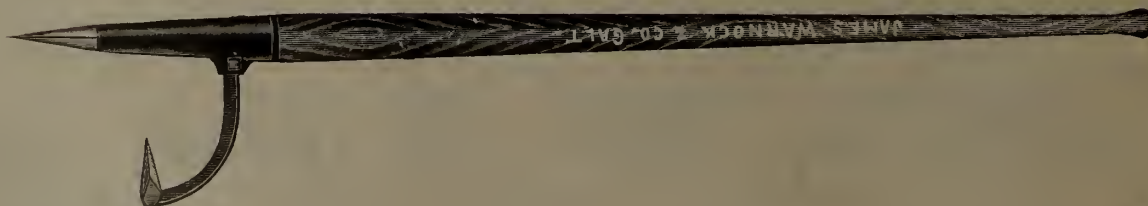
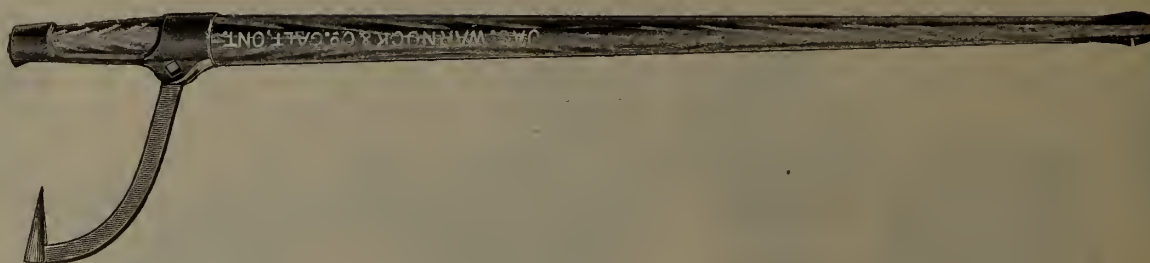

THE JAMES WARNOCK CO., LIMITED
GALT, ONT.

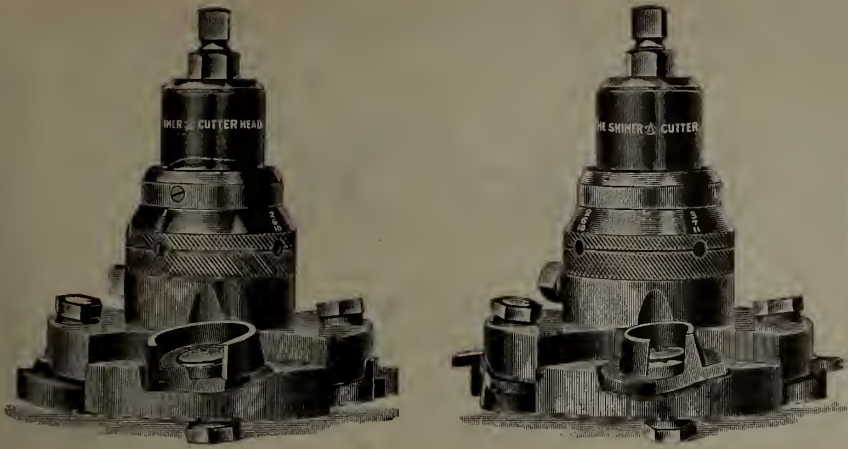

The Shimer Gutter Head

FOR FLOORING, CEILING, SIDING, SHIP LAP,
JOINTING, DOUBLE CEILING, DOORS, SASHES,
BLINDS, etc. SPECIAL TOOLS for Special Service

Should appeal to every user of a Matching, Moulding or Tenoning Machine because it does more and better work than others and requires less labor and expense to keep it in order.

We make it of every size and style to fit any machine and send on trial 30 days to responsible lumbermen.

Send for our 1905 Catalogue. It gives illustrations and complete description of a number of these tools, some of which will be of advantage to you.

SAMUEL J. SHIMER AND SONS

Milton, Pennsylvania

RUBBER BELTING

For
Transmitting
Elevating
and
Conveying



Rubber
Hose
for
Water
Steam
Air
Suction
Fire
Protection

THE CUTTA PERCHA & RUBBER MFG. CO.

OF TORONTO, LIMITED.

HEAD OFFICES: 47 YONGE STREET, TORONTO, CAN.
Branches: Montreal, Winnipeg, Vancouver.

New 200 Page Green Book

1904 EDITION.

"Saw and Knife Fitting Machinery and Tools"

MAILED FREE ON REQUEST.

A Book for Mill and Factory Managers, Superintendents, Foremen and Saw Filers.

BALDWIN, TUTHILL & BOLTON,

GRAND RAPIDS, MICH., U.S.A.



B. T. & B. Full Automatic Knife Grinder. Style D.

SAW AND KNIFE FITTING

THE NEW B. T. & B. MANUAL

Revised edition. 144 pages. Copiously illustrated and Durably Bound. Is an exhaustive treatise on the care of Saws and Knives.

A Practical Book for Saw Filers.

Mailed Postpaid on Receipt of Price

\$2.00

THE "B. T. & B." LINE

NEED ANYTHING?

Sharpeners, Swages, Stretchers, Shapers, Side Files, Shears, Retoothers, Brazing Machines, Filing Clamps, Lap Grinders, Lap Cutters, Patch Machines, Crack Drills, Hammering Benches, Bench Grinders, Band Filers, Band Setters, Pulleys and Stands, Brazing Forges, Saw Sets, Saw Gauges, Swage Bars, Upsets, Straight Edges, Tension Gauges, Back Gauges, Leveling Blocks, Anvils, Hammers, Speed Indicators, Emery Dressers, Knife Grinders, Knife Balances, Shingle Saw Grinders, Burr Gummers, Post Brackets, Stretcher Bench Brackets, Cutters, Marking Stamps, Saw Guides, etc.

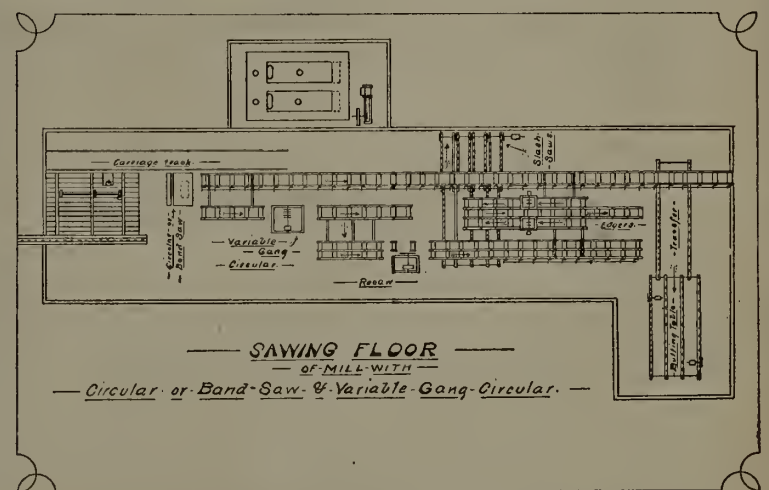

Sawing Floor of Mill with Circular or Band Saw and Variable Gang Circular

For cutting large and small logs at the same time, profitably, this mill has no equal. The variable Gang Circular (which takes the place of an upright gang) cuts the cants into any thickness from 1" to 9" by whatever width the cant has been slabbed to up to 10', and each cant put through may be cut into different sizes from the one immediately preceding or following it. Plans and estimates made of all kinds of sawmill work; machinery supplied and mills built if desired.

I. N. KENDALL

203 BRIDGE ST.

OTTAWA, ONT.

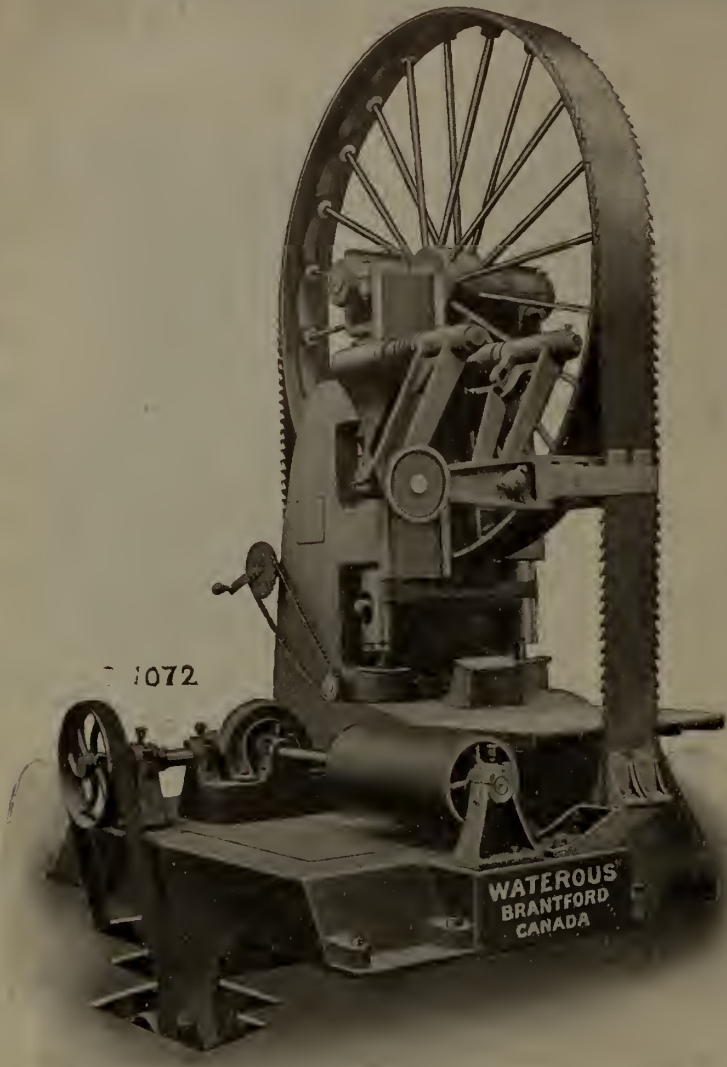

17 to 30% SAVED

By Cutting Small Logs with

DOUBLE CUTTING BAND MILL

Instead of with CIRCULAR

This Illustration shows our DOUBLE CUTTING PONY BAND MILL, 6 foot Wheels, Suitable for Portable or Stationary Mills

We Manufacture a Special
Complete Line of

Saw Mill Machinery

Designed Expressly for
Use with the

Pony Band Mill

We Can Supply Anything Necessary
for the Equipment of Any
Size Saw Mill

Send for our new No. 32A Circular



One of the many Double Cutting Band Mills with 8 ft. Band Wheel in Actual Operation

WATEROUS, BRANTFORD, CANADA

NATURAL DRAFT . . . DRY KILNS

**LUMBER TRUCKS and
TRANSFER CARS**

Write for prices and particulars of the most simple and efficient Natural Draft Dryer on the market. Testimonials and list of users sent on application. Every square inch of heating surface is utilized to the uttermost and perfect ventilation and circulation is obtained by a very simple arrangement of ducts. Write for particulars to

**SHELDON & SHELDON,
GALT, ONT.**

FORMERLY McEACHREN HEATING & VENTILATING CO.



**Experimenting with Dry Kilns
is an Expensive Luxury**

Why keep on using a Kiln that has to be regulated with dampers, chimneys and complicated fans. Put in a Morton Automatic Moist Air Kiln and your Dry Kiln troubles will be ended. We do not sell a man a Dry Kiln to dry Mahogany and then tell him it will dry Basswood staves. Our thirty years experience in the Dry Kiln business yours for the asking.

Write to-day for Illustrated Catalogue "C"

The A. H. Andrews Co.

174-176 Wabash Avenue - - CHICAGO, U.S.A

Eby Machinery Co., Western Agents, 17-19 Main St., San Francisco, Cal.



**THE HIGHEST ACHIEVEMENT
IN TRUCK CONSTRUCTION**

Standard Dry Kiln Trucks are best for your plant because they run more lightly, give less trouble and last longer than any other truck on the market. This we prove and guarantee.

Not only do they possess every modern feature of truck construction, but a number of the most valuable points about them are patented by us and cannot be reproduced in other trucks.

Standard Trucks have malleable iron wheels and spreaders; channel steel frame; steel rollers with cone-shaped ends that minimize the friction; lath-cut axles with milled ends, and many other advantages that are explained and illustrated in our printed matter.

Write for our Catalogue "D" and learn more about these better dry kiln trucks.

The Standard Dry Kiln Co.
Indianapolis, Indiana

USE

"MIDLAND" BABBITT METAL

IN YOUR BEARINGS

None Better

**GEORGIAN BAY ENGINEERING WORKS
MIDLAND, ONT.**



FOR **DRY KILNS**

that will season-lumber of all kinds and under all conditions, whether partially air-seasoned or green from the log, in shortest time and at least cost, entirely free from cheching, warping or case hardening,

Write to—

McEACHREN HEATING & VENTILATING COMPANY, GALT, CANADA

HUTHER BROS. PATENT GROOVER OR DADO HEAD
For cutting any width groove from 1/4-inch to 2 inches or over



Can be used on any Circular Saw Mandrel. Will cut a perfect groove with or across the grain. This is the only Dado Head on the market that gives entire satisfaction on all classes of work. No screw adjustment. For different width grooves, simply remove or add inside cutters. Sold by ap-builders and dealers of woodworking machinery in all parts of the United States. Will send on approval, in competition with any other make on the market; if not the best return at our expense. HUTHER BROS., Platt Street, ROCHESTER, N.Y., manufacturers of Circular Saws, Morgan Pattern Lock-Corner Box Cutters, Concave Saws, etc.

LUMBERMEN'S LOG STAMPS
STEEL & RUBBER STAMPS, BRASS STENCILS, ETC.
THE SUPERIOR MFG. CO.
COR. BAY & ADELAIDE STS. TORONTO, CAN.
Write for Catalogue.

JNO. S. FIELDING, C. E.
WATER POWERS AND DAMS
Room 2, 15 Toronto Street - TORONTO

WIRE ROPE



Special Alligator Ropes any lengths, fitted with proper attachments
Saw Carriage Ropes
Haulage Ropes
Elevator Ropes
Smoke stack stays, &c.
Standard and Lang's Patent Lay

THE B. GREENING WIRE COMPANY, LIMITED
HAMILTON, ONT. MONTREAL, QUE

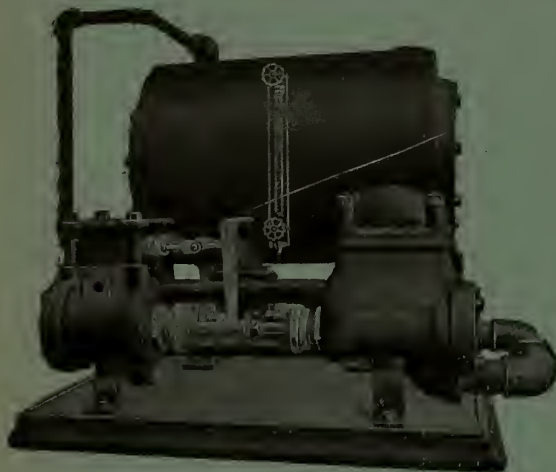

AUTOMATIC FEED PUMP AND RECEIVER
STEAM and POWER PUMPS
ENGINES BOILERS
THE SMART TURNER MACHINE COMPANY Limited.
Hamilton - Ontario

Uncle Sam would not allow his battleships to be babbitted with inferior babbitt metal. New Battleship "Nebraska" is lined with Syracuse Babbitt. Always specify best. It is cheapest in the long run.

SYRACUSE SMELTING WORKS

MONTREAL NEW YORK SEATTLE

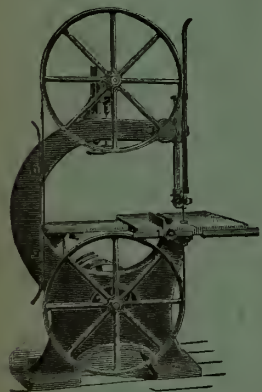

CRESCENT MACHINERY

Quality is all right. So's the price.

Band Saws
Jointers
Saw Tables

Very low price on **BAND SAW BLADES**
Catalogue tells the rest.

H. W. PETRIE
Dept. C. M.
TORONTO, ONT.



THE LEATHER BELT THAT'S KNOWN
OUR "EXTRA"



MONTREAL WINNIPEG TORONTO VANCOUVER

PINK LUMBERING TOOLS

The Standard Tools

In Every Province of the Dominion, * * * * *
* * * * * New Zealand, Australia, Etc.



Pink Round Bill Peavey, Handles in Split Maple

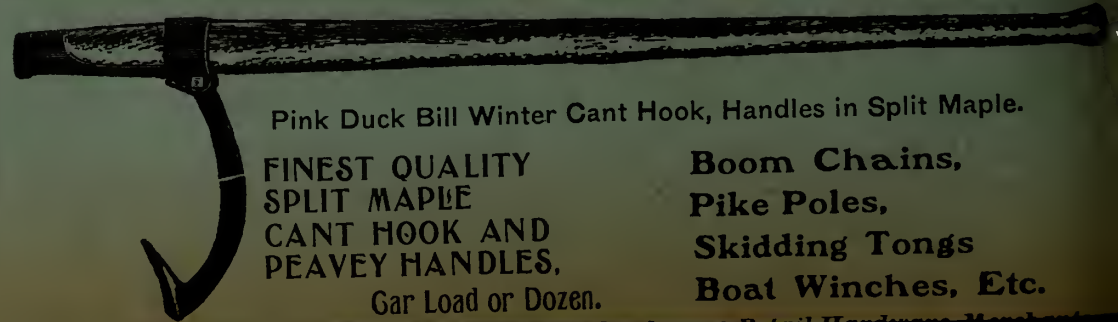

Pink Duck Bill Winter Cant Hook, Handles in Split Maple.

FINEST QUALITY SPLIT MAPLE CANT HOOK AND PEAVEY HANDLES,
Car Load or Dozen.

Boom Chains, Pike Poles, Skidding Tongs, Boat Winches, Etc.

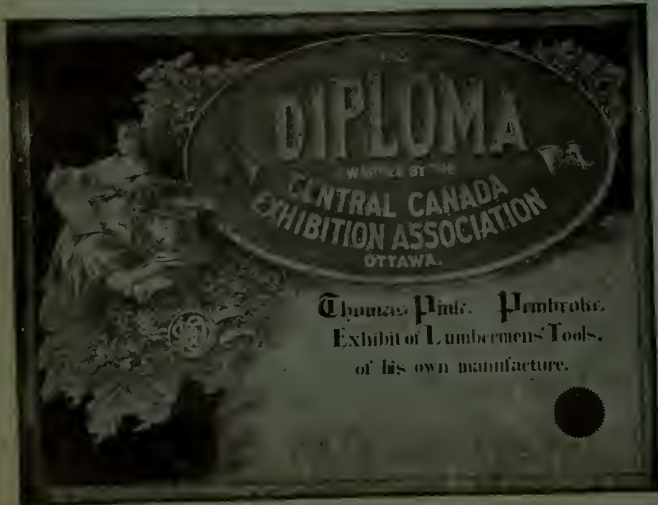

THOMAS PINK
Pembroke, Ont.

CANADA LUMBERMAN AND WOOD-WORKER

REACHES REGULARLY MANUFACTURERS, BUYERS AND SELLERS OF TIMBER PRODUCTS IN EVERY PART OF CANADA AND LEADING IMPORTERS ABROAD

VOLUME XXV. }
NUMBER 11. }

TORONTO, MONTREAL — NOVEMBER, 1905 — WINNIPEG, VANCOUVER

TERMS, \$1.00 PER YEAR
Single Copies, 10 Cents.

SNOW PLOW

Logging Sleighs
Heavy Waggon

THE WILKINSON PLOUGH COMPANY, LIMITED
TORONTO, CANADA



Which is Wisest?

Some people buy Belting on price, others on quality. Which is wisest?

J. L. GOODHUE & CO.,
DANVILLE, QUEBEC.

D. K. McLaren
GENUINE

Oak Belting
MILL SUPPLIES

751 Craig St., Montreal
196 King Street West, Toronto
169 Prince William St., St. John, N. B.

WOODS LIMITED

Wholesale Manufacturers of . .

LUMBERMEN'S AND CONTRACTORS' SUPPLIES

INCLUDING

Tents, Flags, Awnings, Tarpaulins, Clothing, Overalls, Shirts, Mitts, Underwear, Blankets, Axes, Moccasins, Woods Celebrated Eider Down Sleeping Bags

WOODS BUILDING - OTTAWA, CAN.

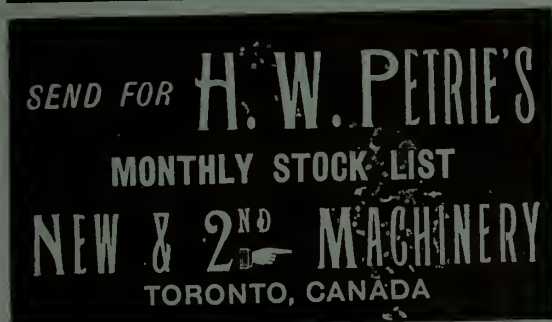

DICK'S BELTINGS



Never is affected by wetness, and does not stretch

Excels in Transmission Power

Always Uniform.

LARGE STOCK ON HAND

WRITE TO SOLE AGENTS:

J. S. YOUNG, 14 Hospital Street MONTREAL

The Atlas Car Mover



will move any car. All the force applied goes in a forward shove which is irresistible.

W. H. C. MUSSEN & CO.
MONTREAL.

MANUFACTURERS OF

HIGH GRADE
CIRCULAR AND LONG SAWS
UNEXCELLED
SHINGLE SAWS



OUR INSERTED TOOTH SAW POSITIVELY THE BEST

The Wm. Hamilton Mfg. Co. Limited

Builders of a Complete Line of

MODERN SAW MILL MACHINERY

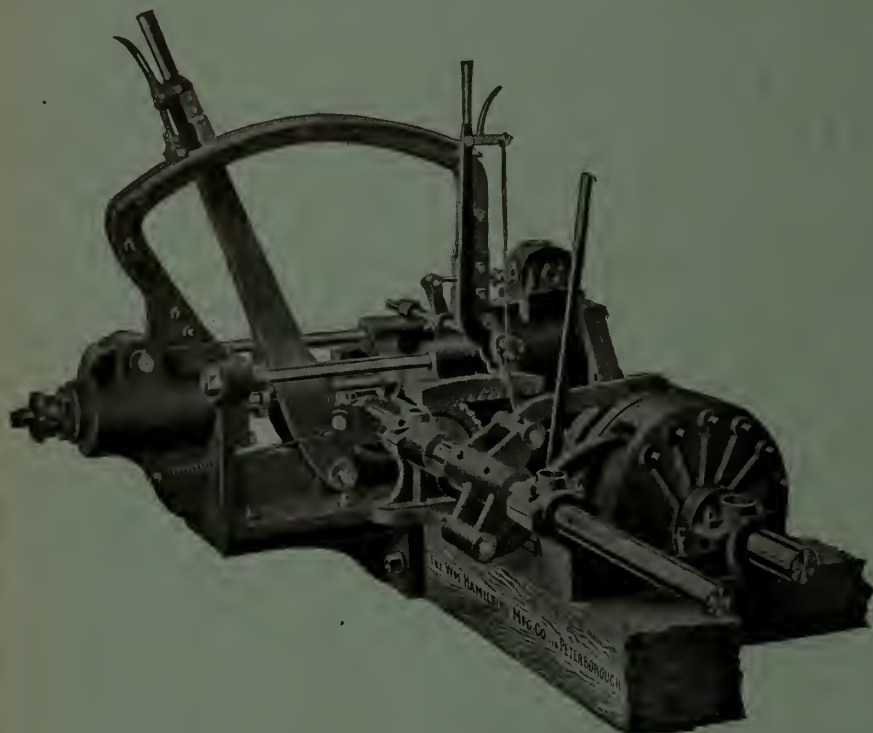

IMPROVED STEAM SETTING MACHINE

With Enclosed Dirt-Proof Ratchet Set Works.

This machine has all the advantages of steam setting machines, and in addition is larger and more powerful than others now on the market. It will set up to four inches with one throw of the lever, and will handle easily the largest log that can be cut on rack and pinion head blocks.

It is an ideal set works for a mill where quick and true work is an object, and it is giving satisfaction in more than a hundred mills.

A post card will bring our book, "Setting Machines for Sawmills", showing numerous different set works to meet all requirements.

IMPROVED "HAMILTON" LATH MILL

This machine was designed and built specially for handling a large output of lath per day. It is very strong and rigid, and is made throughout of the best material. It has a capacity of sixty thousand lath in ten hours.

It is fitted with an improved device for preventing the bolts from flying back, thus making it perfectly safe to the operator.

We build a complete line of lath mill machinery, and have just issued a booklet showing this class of machinery, suitable for mills of any size, and will send a copy anywhere on request.



Head Office and Works: PETERBOROUGH, ONTARIO

Branch Office: VANCOUVER, BRITISH COLUMBIA

Up-to-Date Sawmill Machinery

Head Offices :
MONTREAL.

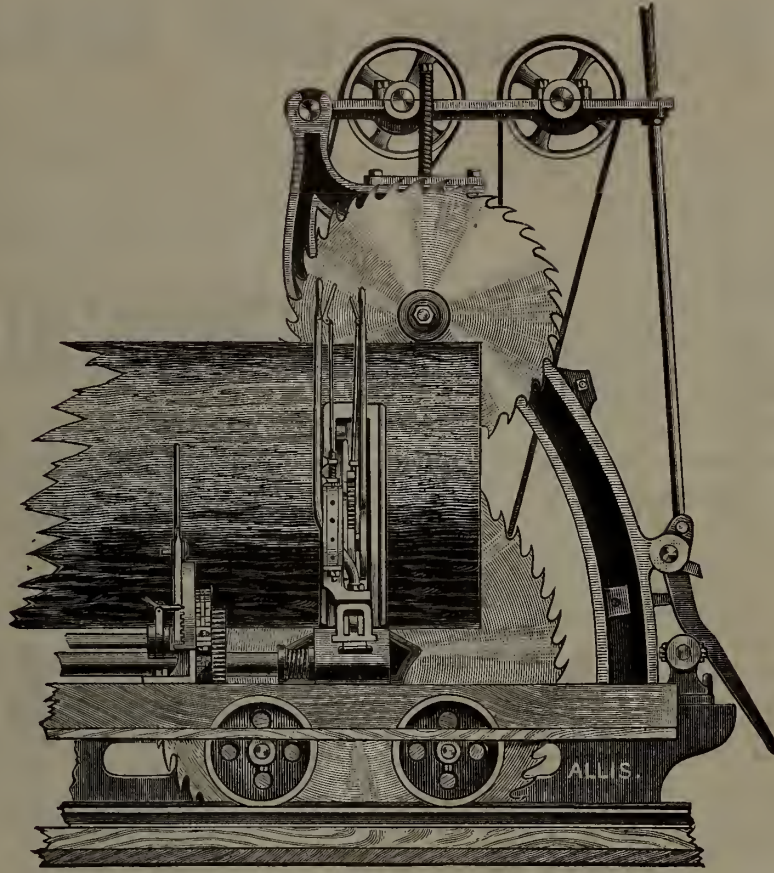

No. 1 Single Circular Mill with Inverted Top Saw Hanging.

Branch Offices :
HALIFAX, TORONTO, WINNIPEG,
NELSON, VANCOUVER.

Allis-Chalmers-Bullock, Limited

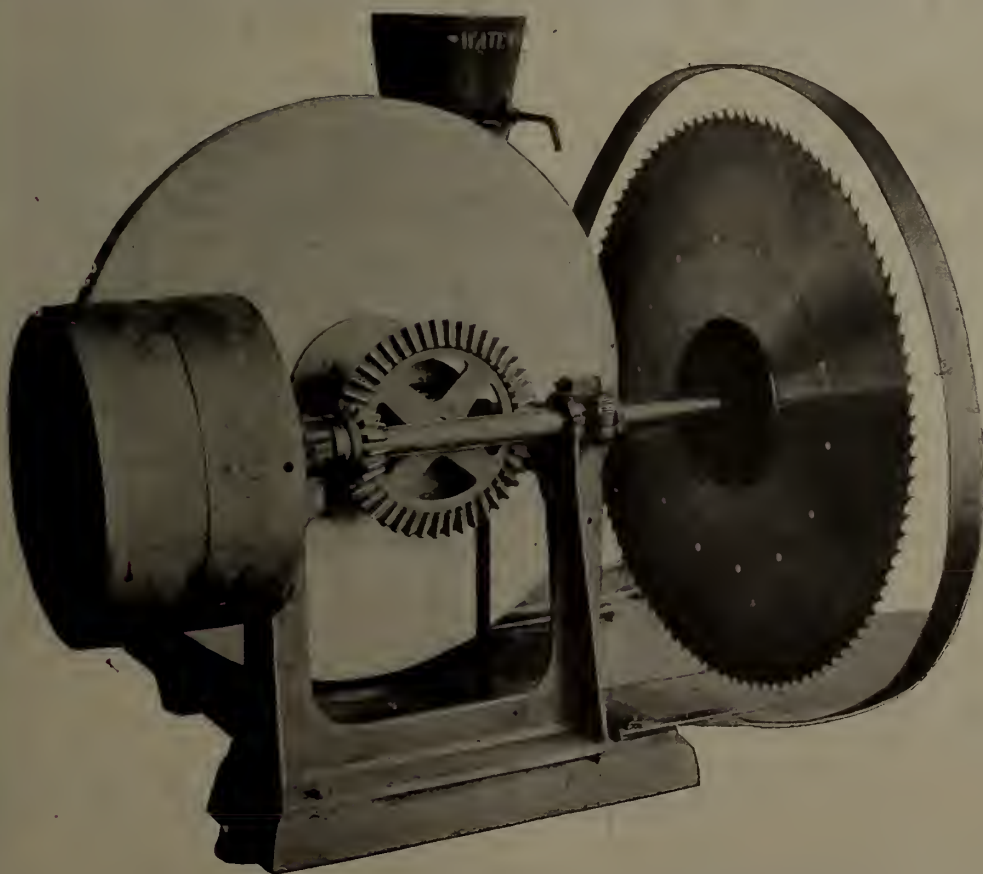

Shingle Saw Grinder

FOR keeping down the thickness of shingle saws and thereby saving timber, we are now putting on the market a grinding machine. Several of these machines have been running in different mills for some months. It will at once be seen that we have made a radical change from anything at present on the market for this purpose. The saws are ground much quicker with the grindstone than with the emery wheel. It is also found that the grindstone does not roll the saws out of shape as the emery wheels do. The cut shows the machine so clearly that very little, if any, explanation is necessary. The shaft on which the saw is fastened is driven direct with the belt; the grindstone being driven with a bevel gear and pinion. The grindstone is made to move back and forth by the cam. The grindstone shaft is not at right angles to the saw shaft, but at an angle equal to the taper on the saw. This angle can be made greater or less by turning the eccentric sleeve in which one end of the shaft runs. The position of the feeding cam can be adjusted in or out by slacking up the bolts holding it and pushing it in the direction wanted. The machine is simplicity itself, and as will be seen, is built very strong.

MANUFACTURED ONLY BY



Letson & Burpee, Limited, Vancouver, B. C.

BRITISH COLUMBIA LUMBER AND SHINGLE MANUFACTURERS

The Canadian Pacific Lumber Co., Limited
PORT MOODY, B. C.

Manufacturers and Wholesale
Dealers in All Kinds of

B. C. LUMBER, LATH, MOULDINGS, ETC.

Special Attention Given to Orders from Manitoba and the Territories  Long Distance Telephone Connection.  Address the Company at Port Moody or **BYRNES & CUDDY, Selling Agents, WINNIPEG**

PETER LUND, Managing Director. J. BRECKENRIDGE, President.

Grows Nest Pass Lumber Co., Limited
WARDNER, B. C.



MANUFACTURERS OF ALL KINDS OF

BUILDING MATERIAL

Capacity 150,000 Feet Per Day.

Columbia River Lumber Company, Limited
HEAD OFFICE AT GOLDEN, B. C.

Largest Capacity in Mountains

MILLS AT { GOLDEN, B. C.
BEAVER, B. C.
KAULT, B. C.
CARLIN, B. C.

ROUGH AND DRESSED

LUMBER

FIR, SPRUCE
CEDAR AND PINE

LATH

Telephone Poles,
Piling, Etc., a
Specialty.

The Fernie Lumber Co., Limited, Fernie, B. C.

MANUFACTURERS OF AND DEALERS IN ALL KINDS OF

ROUGH AND DRESSED LUMBER

Dimension and Bridge Timber a Specialty.

Moulding in Stock or Made to Order.

JOS. GENELLE, Manager.

J. G. BILLINGS, Secretary.

THE YALE-COLUMBIA LUMBER COMPANY, LIMITED

Head Office: NAKUSP, B. C.

Mills at Nakusp, Westley and Cascade, B. C.

MANUFACTURERS OF

DEALERS IN

All Kinds Rough and Dressed Lumber,
Mouldings, Lath, Etc.

Cedar and Fir Piles, Telephone and
Telegraph Poles, Fence Posts, Etc.

NORTH STAR LUMBER COMPANY,

Head Office and Shipping Yards: ELKO, B. C.

Mills: CRANBROOK, B. C.

At present we have the following material in stock at Cranbrook, B. C.:

- 1,750,000 ft. Common Boards.
- 300,000 " Stock Boards, 8 in., 10 in. and 12 in.
- 300,000 " Shiplap, 8 in., 10 in. and 12 in.
- 100,000 " Flooring, Siding and Ceiling, 4 in. and 6 in.
- 1,550,000 " Dimensions, 8 to 24 ft.

We have a large quantity of 18 and 20 ft. lengths, from 2 x 4's to 2 x 12's.

The above is manufactured from a superior quality of pine, fir and tamarack logs. 75 per cent. of it is "bone dry."

Special sized timbers cut on short notice. Write for prices

MANUFACTURERS OF AND WHOLESALE
DEALERS IN

B. C. WHITE PINE LUMBER and LATH

Write Us About Our LARCH LUMBER

Factory Lumber

and

Tank Stock

A Specialty



BRITISH COLUMBIA LUMBER AND SHINGLE MANUFACTURERS

FIR, CEDAR and SPRUCE LUMBER and FINISH

PROMPT

FIR TIMBER, Etc

Dressed to 30 x 30 x 90.



MOULDINGS TURNINGS and LATH

SHIPMENTS

RED CEDAR SHINGLES

"Cascade Brand" Always the Best

Scribner's Lumber and Log Book

A handy book for Lumbermen. Gives Correct Measurements of Scantlings, Boards and Planks: Cubical Contents of Square and Round Timber; Doyle's Rules, and other much practical information.

Price 35 Cents

THE CANADA LUMBERMAN
TORONTO, ONT.

BLUE & DESCHAMPS

Manufacturers of

Tamarac, Hemlock, Spruce Fir, Cedar and White Pine

MILL AND OFFICE: ROSSLAND, B. C.

China Creek Lumber Co., Limited

Manufacturers of

Fir, Tamarac and Yellow Pine

WE MAKE LATH

Mill at CHINA CREEK Office at ROSSLAND, B. C.

The MAYOOK LUMBER COMPANY, Limited

MANUFACTURERS OF **LARCH, PINE AND FIR TIMBER**

Head Office: MAYOOK, B. C. WINNIPEG Office: 445 Main Street

Saw and Planing Mill at MAYOOK, B. C.

CEDAR LUMBER

Manufacturers and Shippers

Cedar, White Pine, Fir Lumber, Lath, Mouldings, Shingles

Bowman Lumber Co., Ltd.

Revelstoke, B. C.

Mills at { REVELSTOKE, B. C. COMAPLIX, B. C.



ROSS BROS & GO.

FORMERLY OF WHITEMOUTH; MAN.

SUCCESSORS TO THE ELKMOUTH LUMBER CO.

ELKMOUTH, BRITISH COLUMBIA

Full Lines Kept in

Pine, Fir and B. C. Tamarac

ORDERS RESPECTFULLY SOLICITED

Send for Our Prices

Advertisements in the CANADA LUMBERMAN bring results—try one.

THE EAST KOOTENAY LUMBER CO., Limited

Saw and Planing Mills at Ryan, Cranbrook and Jaffray, B. C.
Capacity, 150,000 Feet Per Day

MANUFACTURING

LARCH
PINE and FIR

Lumber, Timber, and all kinds of Mouldings, also dealers in Railway Ties, Piles and Poles

Large Stocks of Well Seasoned Dry Material Always on Hand

HEAD OFFICE

CRANBROOK, B. C.

USE

MUNDY'S QUALITY

AIR-DRIED LUMBER AND SHINGLES

THREE VALLEY P. O., B. C.

The Ladysmith Lumber Co., Limited

LADYSMITH, B. C.

Manufacturers of

LUMBER, LATH, SHINGLES, MOULDINGS, ETC.

SPECIALTY: The best Cedar Shingles manufactured on the Coast.

FRESH WATER FIR LATH ALWAYS IN STOCK.

Capacity of Shingle Mill, 100,000 per day of 10 hours.

Correspondence Solicited

The Cook & Bros. Lumber Co.

Of Ontario, Limited
MILLS at SPRAGGE, Algoma Dist., Ont.
on "Soo" Branch C.P.R.

OFFICES (Manning Arcade, Toronto
Coristine Building, Montreal
And at Mills at Spragge.

MANUFACTURERS OF

White and Red Pine Lumber and Lath

Water Shipments

For Fans, Separators, Dust Collectors Blowers and Shavings Systems Heating and Dry Kiln Systems

SEND FOR CATALOGUE TO

HINRICH & PACE

Revelstoke, B. C.

Get Rid of Your Trouble

with Gears, which are eating up too much of your power, by putting in a Horizontal Setting as shown here. This is the Modern Way and also the Economical Way, for it will save you Water, Power, Time and Money. This cut shows a Globe case containing a Triumph Turbine, with elbow, two pulleys, one of which may be cut off by a clutch, and governor, all mounted on the one steel frame. This setting is self-contained, rigid and durable, and permits a direct belt drive to the machine to be driven.

Our Triumph Wheels placed horizontally give from 5 to 10 per cent. better results than any other wheel, owing to their perfect discharge. For light powers with limited water our Improved Standard Leffel and Vulcan Wheels have no equals. If you are developing a new power or replacing an old setting, let us figure with you. We can furnish any style of setting for any head or power, and our experience in this line is at your service.

We also build the Improved Lane Circular Saw Mills with capacities of from 5 to 50 M. per day, Shingle Machines and all Machinery for making lumber, lath or shingles.

Our new Tie Machine will make 1200 Ties in 10 hours. It's worth investigating.

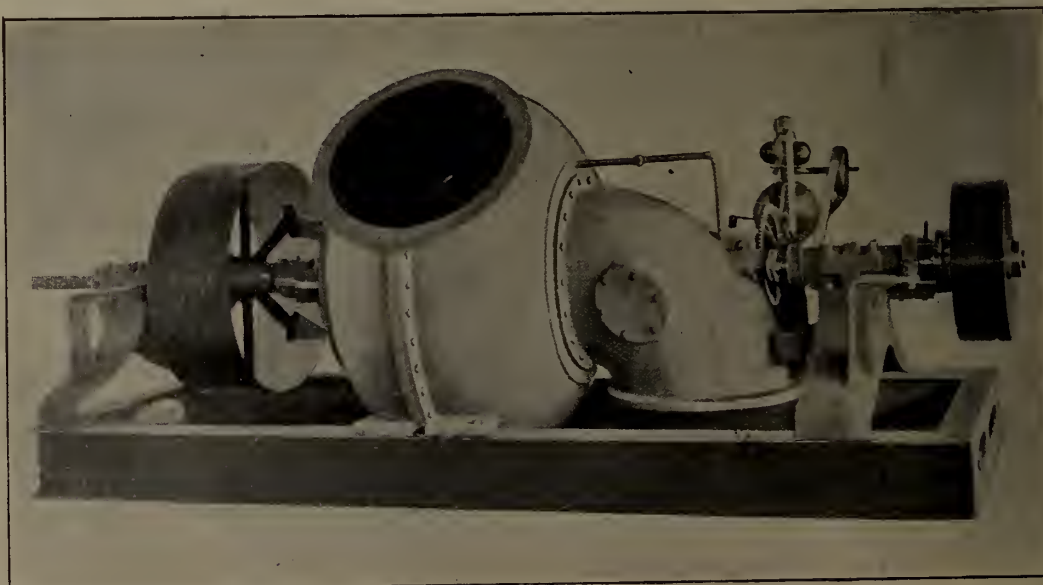

MADISON WILLIAMS

Successor to Paxton, Tate & Company
PORT PERRY, ONT.

H. E. PLANT, Agent
Cor. Common and Nazareth Streets
Montreal, Que.

Manitoba Iron Works
Western Selling Agents
Winnipeg, Man.

FRANK DENTON, K. C. HERBERT L. DUNN
 W. MULOCK BOULTBEE.
DENTON, DUNN & BOULTBEE
 Barristers, Solicitors, Notaries, etc.
 National Trust Chambers. TORONTO

DO YOU USE IT?
BAUGHMAN'S BUYER & SELLER

THE HANDY BOOK FOR LUMBERMEN
 Saves half the time and all the mistakes in
 figuring Invoices, Estimates and Invento-
 ry. Send for sample copy.

Flexible Cloth \$1.00
 Flexible Leather 1.25

Sample Page Free. Address

H. R. H. BAUGHMAN
 INDIANAPOLIS, IND, U. S. A.

MONTREAL BELTING CO.
 595 St. Paul St., MONTREAL
 Manufacturers
ENGLISH OAK TANNED
LEATHER BELTING
 Discounts 60, 10 and 5 Off Lists

DO NOT

underestimate the importance of checking your
 figures when ascertaining contents of cut ma-
 terial in 4/4, 5/4, 6/4 or 8/4 lumber, or surface
 measure for veneers, etc., for boxes, mill work,
 furniture, etc. Save time, labor, brainwork,
 and prevents errors by using the comprehen-
 sive, successful and highly recommended
 "Box Estimator" which gives results, deci-
 mally expressed, at a glance.

Sent on Trial.

J. M. LEAVER,
 Sault Ste. Marie, Mich.

The Manitoba Gypsum Co.

MANUFACTURERS OF

LIMITED

HARDWALL PLASTER WOOD FIBRE PLASTER
 PLASTER OF PARIS STUCCO ALABASTER
 and All Kinds of Gypsum Products

The Only Plaster Co. in Western Canada

Quality of goods superior to any imported article, our mill being equipped with the
 latest improved machinery.

Dealers are invited to get our quotations before placing orders for Spring requirements

Office: 811 UNION BANK BUILDING, WINNIPEG

D. E. ROBERTS Lately in charge of the Plymouth
 Plaster Co., at Fort Dodge, Iowa.
 Superintendent of Manufacture

WM. MARTIN
 General Manager

THE ORIGINAL AND ONLY PERFECT
CHISEL-TOOTH SAW
 ALL OTHERS ARE IMITATIONS.



GOLD MEDAL (HIGHEST AWARD)
 ST. LOUIS, 1904.

SEND FOR NEW ILLUSTRATED CATALOGUE,
 WITH NEW PRICES AND NEW DISCOUNTS.

R. HOE & CO.
 504-520 GRAND STREET,
 NEW YORK, N. Y.

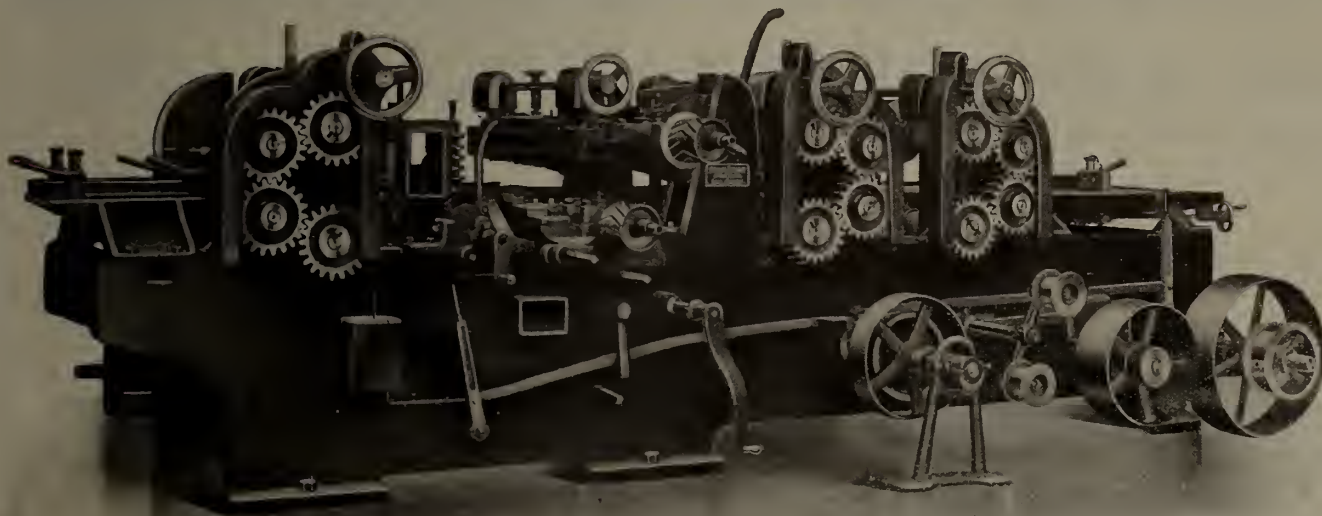

PLANER AND MATCHER

M 169

Made in several sizes; all fitted with wedge platen for instantly adjusting, regulating and distributing the cut between the cylinders; the greatest labor saver embodied in planing mill machinery. We manufacture a full line of wood working machinery. Write for prices and particulars.

COWAN & COMPANY
 OF GALT, LIMITED
 GALT, - CANADA

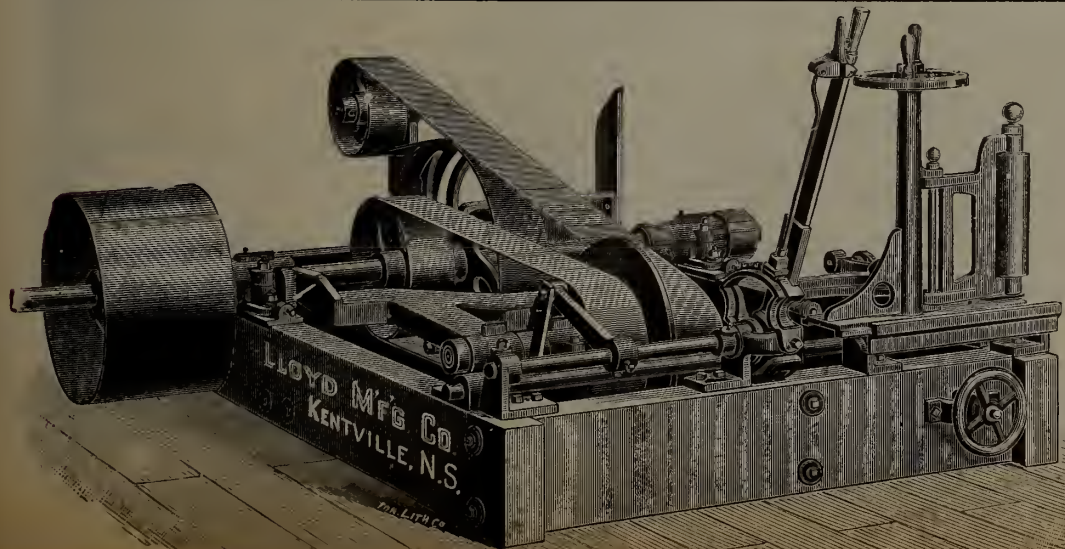

Lloyd Manufacturing
 Go'y JOHN I. LLOYD, Proprietor.

SAW MILL OUTFITS

Pulp Machinery, Belting, Etc.

OUR SPECIALTIES:

- Band Saw Mill Machinery,
- Improved Rotary Saw Mills,
- with Green Mountain Dogs,
- Also Screw Post Dogs,
- Turbine Water Wheels,
- Power Feed Gang Edgers
- Buzz and Surface Planers,
- Heading Rounders,
- Stave Machines, Stave Jointers
- Stave Planers.

KENTVILLE, N. S.

**"DEFIANCE"
Wood-Working Machinery**

For Manufacturing
**HUBS, SPOKES, WHEELS, WAGONS,
CARRIAGES, RIMS, SHAFTS, POLES,
NECK-YOKES, SINGLE TREES, BARREL
HOOPS.**

Handles of Every Kind, Insulated Pins, Spools,
Bobbins, Oval Wood Dishes, and General Wood-
Work.

Invented and Built by

THE DEFIANCE MACHINE WORKS,
Defiance, Ohio, U. S. A



"D" SHOVEL HANDLE LATHE



OVAL WOOD DISH MACHINE



The **"Alligator"** Steam Warping Tugs

SIDE WHEELS OR TWIN SCREWS

The Twin Screws are arranged with flexible joint to
raise up in crossing portage

MANUFACTURED BY

WEST & PEACHEY, - Simcoe, Ont.

Cables carried in stock for renewals

THE E. LONG MANUFACTURING CO., ORILLIA, ONT.

We build Double Edgers, Steam Feeds, Log Jacks, Live Rolls, Trimmers, Slab Slashers, Steam Niggers.

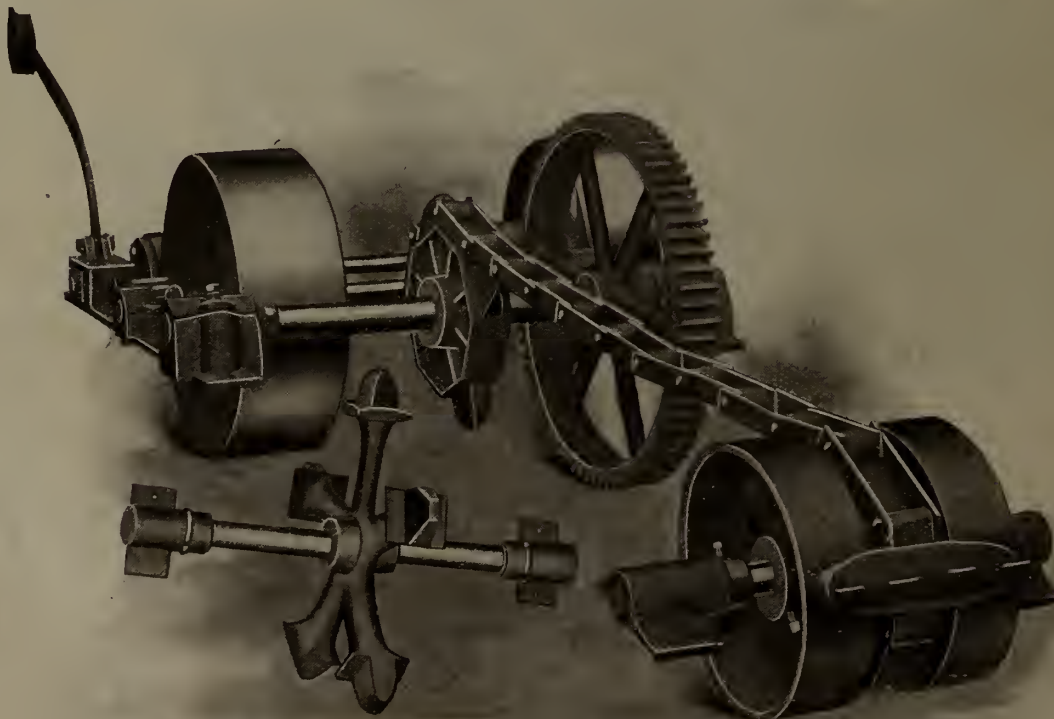

COMPLETE LINE OF SAW AND SHINGLE MILL MACHINERY
WRITE FOR CATALOGUE AND PRICES

THE MAPLE LEAF SAW WORKS



Shurly & Dietrich GALT, ONT.

Manufacturers of

**CIRCULAR SAWS
GANG SAWS
MILL SAWS
BAND SAWS
CROSS-CUT SAWS**

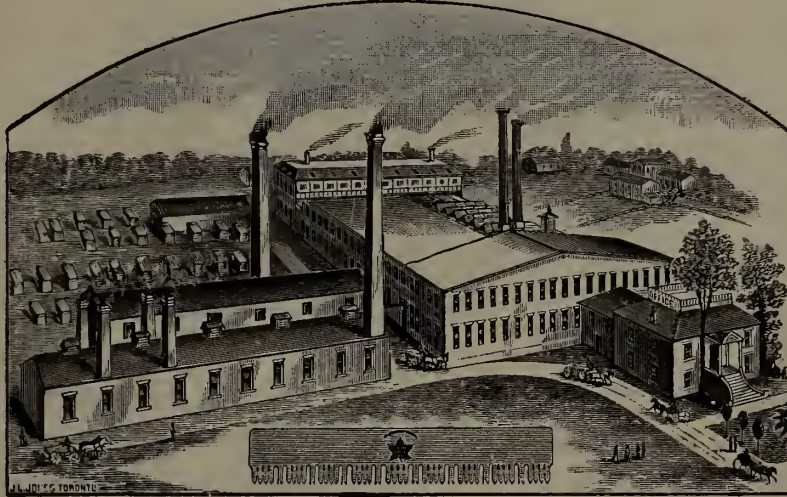

Manufacturers of

**HAND SAWS
BUCK SAWS
PLASTERING TROWELS
BUTCHER SAWS
STRAW KNIVES, &c.**



GROUND THIN ON BACK
Save Labor Save Gumming
Save Time Save Files

This Saw Stands Without a Rival

AND IS THE

FASTEST CUTTING SAW IN THE WORLD!

Its Superiority consists in its Excellent Temper. It is made of "Razor Steel," which is the finest ever used in the manufacture of Saws. We have the sole control of this steel. It is tempered by our secret process, which process gives a keener cutting edge and a toughness to the steel which no other process can approach.

Maple Leaf Saw Set

MANUFACTURED BY

SHURLY & DIETRICH, Galt, Ont.

Directions.—Place the set on the point of tooth, as shown in the accompanying cut, and strike a very light blow with a tack hammer. If you require more set, file the tooth with more bevel.
If you follow directions you cannot make a mistake. Be sure and not strike too hard a blow, and it will set the hardest saw. On receipt of 40 cents we will send one by mail.

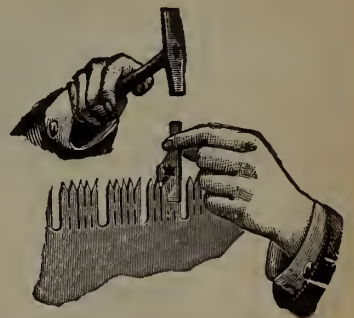

We are the only manufacturers in the world who export Saws in large quantities to the United States.

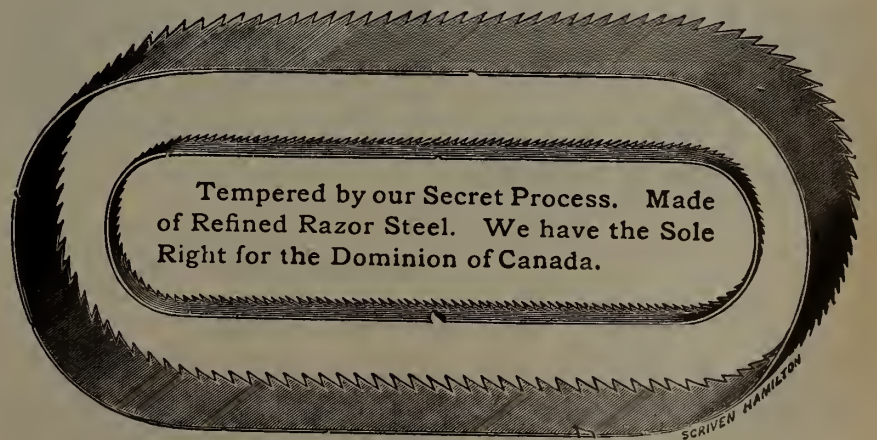

We Manufacture

HIGH GRADE BAND SAWS

Of All Widths and Lengths.

These Saws are made of Refined Swedish Steel imported direct, and tempered by our Secret Process; for Fine Finish and Temper are not excelled.

CLASSIFIED INDEX OF ADVERTISERS

AXES
 Dundas Axe Works. 37
 Warnock Co., James. 39

ALLIGATOR TUGS
 West & Peachey. 8

BELTING
 Beal Leather Co., R. M. 37
 Dominion Belting Co. 38
 Gutta Percha & Rubber Mfg. Co. 41
 Goodhue & Co., J. L. 1
 McLaren, D. K. 1
 McLaren Belting Co., J. C. 44
 Montreal Belting Co. 7
 Waterous Engine Works Co. 38
 Wilby, P. H. 12
 Young, J. S. 1

BABBITT METALS
 Georgian Bay Engineering Works. 43
 Syracuse Smelting Works. 44

BOILERS
 Dymont Foundry Co. 36
 John McDougall Caledonian Iron Works. 30
 Robb Engineering Co. 40

DOORS
 New Century Refrigerator & Mfg. Co. 10

DRY KILNS
 Andrews Co., The A. H. 43
 McEachren Heating & Ventilating Co. 43
 Sheldon & Sheldon. 43
 Standard Dry Kiln Co. 43

EMERY WHEELS
 Hart Corundum Wheel Co., Limited. 28

ENGINES AND LOCOMOTIVES
 Dymont Foundry Co. 36
 Gartshore, John J. 10
 Robb Engineering Co. 40

EDGERS
 Gordon Hollow Blast Grate Co. 40

GRATES
 Gordon Hollow Blast Grate Co. 40

LUMBERMEN'S SUPPLIES
 Beal Leather Co., R. M. 37
 Barr, Alex. 12
 Capstan Mfg. Co. 37
 Johnson, A. H. 47
 Park, Blackwell Co. 37
 Thompson Mfg. Co. 33
 Tobin, Joshua. 28
 Woods, Limited. 1

LUMBER AND SHINGLE MANUFACTURERS
 Bowman Lumber Co. 6
 Cook & Bro. Lumber Co. 6
 Canadian Pacific Lumber Co. 4
 China Creek Lumber Co. 5
 Crows Nest Pass Lumber Co. 4
 Columbia River Lumber Co. 4
 Cascade Mills. 5
 East Kootenay Lumber Co. 5
 Fernie Lumber Co. 4
 Ladysmith Lumber Co. 6
 Mundy Lumber Co. 6
 Mayook Lumber Co. 5
 North Star Lumber Co. 4
 Ross Bros. & Co. 5
 Staples, Otis. 4
 Yale-Columbia Lumber Co. 4

LUMBER DEALERS
 Baughman, H. R. H. 7
 Leaver, J. M. 7

LUMBERMEN'S TOOLS
 Hay Knife Co., Peter. 22
 Pink, Thomas. 44
 Sanford Logging Tool Co. 33
 Warnock Co., James. 39

LUMBERMEN'S AGENTS
 Friel, H. J. 38
 Wright, H. J. 38

LUMBERMEN'S BOOKS
 Knight & Co., G. T. 33
 Osborne & Clark. 34

MISCELLANEOUS
 Alexander Engraving Co. 37
 Bradstreets. 10
 Canadian Office & School Furniture Co. 10
 Clyde Iron Works—Log Loaders. 38
 Canadian Typewriter Co. 33
 Denton, Dunn & Boulthbee, Barristers. 2

Fielding, J. S., Consulting Engineer. 44
 Georgian Bay Engineering Works—
 Grinders. 43
 Huther Bros.—Dado Heads. 44
 Lumber Mutual Fire Insurance Co. 35
 Manitoba Gypsum Co.—Plaster. 7
 Midland Engine Works Co.—Tram
 Car Wheels. 12
 Northwest Steel and Iron Works. 33
 Superior Mfg. Co.—Log Stamps. 44
 Spence & Co., R.—Files and Risps. 10
 Saw Gummer, A. T. McLatchie. 33
 Sessenwein Bros.—Rails. 29
 Toledo Fire Insurance Co. 31
 Vogel, C. H.—Pulp Mill Engineer. 33

OILS.
 Commercial Oil Co. 38
 Canadian Oil Co. 22
 Queen City Oil Co. 10

PROVISIONS
 Eckardt & Co., H.P. 27

PORTABLE SAW MILLS
 Drake, F. J. 36

PLANERS AND MATCHERS
 Cowan & Co. 37

PACKING AND PIPE COVERING
 Garlock Packing Co. 12
 Purvis Co., E. L. 38

ROPE
 Consumers Cordage Co. 35
 Dominion Wire Rope Co. 12
 Greening Wire Co., B. 44
 Mussen & Co., W. H. C. 1

ROOFING
 Bird & Son, F. W. 33

RE-SAWS
 Cowan & Co. 7

SAW SWAGES
 Hanchett Swage Works. 29

SAW GAUGES
 Specialty Mfg. Co. 33

SAWS
 Atkins & Co., E. C. 38
 Burns Saw Co., E. R. 1
 Canadian Saw Co. 31
 Hoe & Co., R. 7
 Shurly & Dietrich 9

SAW MILL MACHINERY
 Allis-Chalmers-Bullock 3
 DeLoach Mill Mfg. Co. 33
 Gordon Hollow Blast Grate Co. 40
 Hamilton Mfg. Co., Wm. 2
 Hinrich & Pace. 6
 Jenckes Machine Co. 38
 Kendall, I. N. 41
 Long Mfg. Co. 8
 Lloyd Mfg. Co. 7
 Manitoba Iron Works. 35
 Mowry & Sons, B. R. 37
 Petrie, H. W. 1
 Payette & Co., P. 35
 Payne Machinery Exchange Co. 33
 Smart-Turner Machine Co. 44
 Savoie-Quay Co. 34
 Waterous Engine Works Co. 42
 Williams, Madison. 6

SHINGLE MILL MACHINERY
 Drake, F. J. 36
 Letson & Burpee. 3
 Long Mfg. Co., E. 8
 Perkins & Co. 12
 Williams, Madison. 5

TURBINES
 Jenckes Machine Co. 38
 Williams, Madison. 6

TRIMMERS
 Gordon Hollow Blast Grate Co. 40

WOODWORKING MACHINERY
 Adde & Co. 34
 American Woodworking Machinery
 Co. 11
 Connell & Dengler Machine Co. 40
 Cowan & Co., Limited. 7
 Defiance Machine Works. 8
 Rogers Iron Mfg. Co. 41
 Sherman Co., W. S. 40
 Shimer & Sons, Samuel J. 41
 Waterous Engine Works Co. 42

The . . .
QUEEN CITY OIL CO. LIMITED
 Head Office: TORONTO.

HIGHEST GRADES OF
Refined Oils
Lubricating Oils

AND ALL
Petroleum Products



ESTABLISHED 1849.
BRADSTREET'S
 Capital and Surplus, \$1,500,000.
 Offices Throughout the Civilized World.
 Executive Offices:
 Nos. 346 and 348 Broadway, NEW YORK CITY, U.S.A.
 THE BRADSTREET COMPANY gathers information that reflects the financial condition and the controlling circumstances of every seeker of mercantile credit. Its business may be defined as of the merchants, by the merchants, for the merchants. In procuring, verifying and promulgating information, no effort is spared, and no reasonable expense considered too great, that the results may justify its claim as an authority on all matters affecting commercial affairs and mercantile credit. Its offices and connections have been steadily extended, and it furnishes information concerning mercantile persons throughout the civilized world.
 Subscriptions are based on the service furnished, and are available only by reputable wholesale, jobbing and manufacturing concerns, and by responsible and worthy financial, judiciary and business corporations. Specific terms may be obtained by addressing the company or any of its offices. Correspondence invited.
THE BRADSTREET COMPANY.
 OFFICES IN CANADA: Halifax N.S. Hamilton, Ont. London Ont.; Montreal, Que.; Ottawa, Ont.; Quebec, Que.; St. John, N. B. Toronto, Ont. Vancouver, B.C.; Winnipeg, Man.
 THOS. C. IRVING,
 Gen. Man. Western Canada, Toronto

RAILS For Logging Tramways, Switches Etc.
YARD LOCOMOTIVES New and Second-Hand.
 John J. Gartshore
 83 Front St. West,
 (Opposite Queens Hotel), Toronto.

R. SPENCE & CO.
 Beech File Works.
 HAMILTON, ONT.
 FILE AND RASP MANUFACTURERS AND RE-CUTTERS
 A trial order solicited. Write for price list and terms.
 C. P. MOORE, PROPRIETOR.

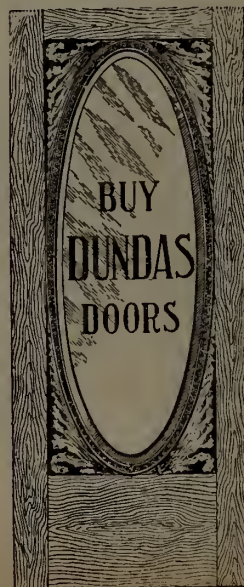

New Century Refrigerator & Manufacturing Co., Limited
 Dundas, Ont., Can.

Our Business is Manufacturing
HARDWOOD VENEER . . . DOORS
 With Built Up Bodies

These Doors are guaranteed not to warp or twist and are superior in construction and finish to any other Door on the market.
 Send for Illustrated Catalogue and Prices.
 Special attention given to Architects' Designs of Doors and Trims.

AGENTS WANTED EVERYWHERE. ADDRESS DOOR DEPARTMENT

30-in. x 12-in. American Endless Bed Single Surfacer

With Sectional Rolls and Power Hoist

Description, Catalogue
and Prices Furnished
on Application.

Investigation
Always Pays.

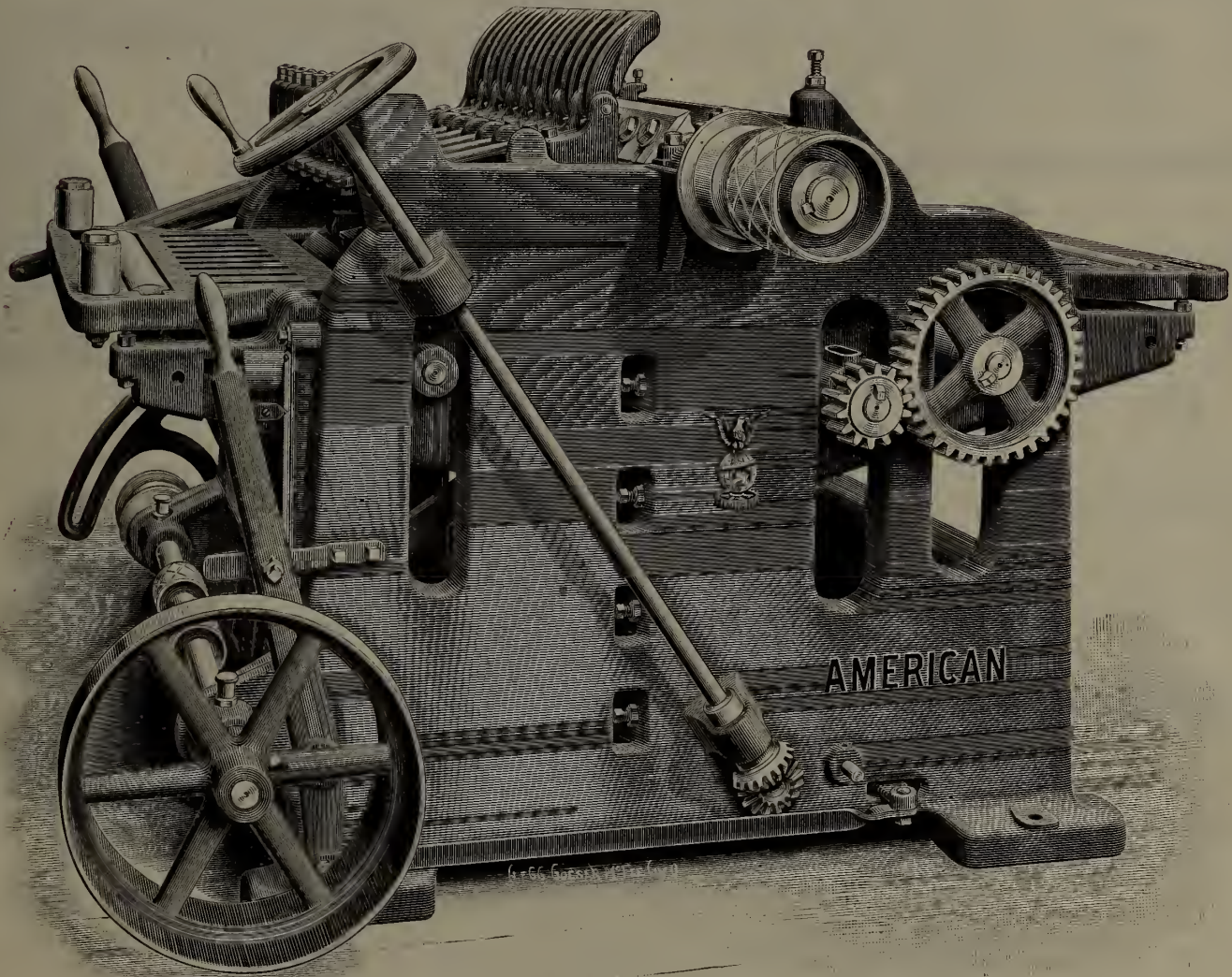
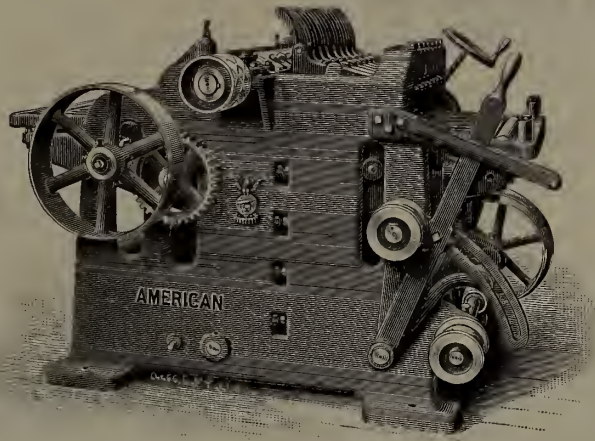

American Wood Working Machinery Co.

Canadian Agents:

The Canadian Fairbanks Co.,
Montreal and Vancouver

New York City,
136 Liberty St.



TEON BELTING



STEAM PFOOF
 WATER "
 HEAT "
 OIL "
 ACID "
 Stronger and Cheaper than
 Leather.

LEATHER BELTING
 CAPATA BELTING [BALATA TYPE]

CAMELS HAIR BELTING
 LACE LEATHER, ETC.

Special Arrangements for Trial Belts.
 Write for Price Lists and Discounts.

P. H. WILBY, 27 1/2 Front Street East, TORONTO

Phone Main 1930.

SOLE AGENT FOR CANADA.

Our special

Tram Car Wheels

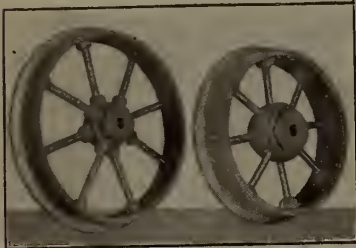

made from a special mixture of Iron,
 are stronger, longer lived, low in
 price and lighter for their strength
 than any other wheel. Write
 for prices and samples of metal.

MIDLAND ENGINE WORKS CO.
 MIDLAND, ONT.

WIRE ROPE FOR ALL PURPOSES IN STOCK

SPECIAL ROPES FOR LUMBERING
 BLOCKS - CLIPS - TURNBUCKLES - ETC.

The DOMINION WIRE ROPE CO., Ltd.
 MONTREAL

EVERY LUMBERMAN WANTS IT

35 cents buys it

Scribner's Lumber and Log Book

BRIMFUL OF EVERY-DAY
 PRACTICAL INFORMATION

Address:
 THE CANADA LUMBERMAN, Toronto

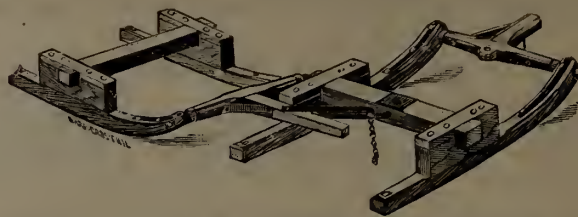

THE LUMBERMEN'S FRIEND

(Desjardin's Patent)
 ALSO

Heavy Runners for Logging Sleighs
 Bent to Order, Poles, Beams, Roll-
 ers, Blocks, and other parts on
 hand at all times.

I ALSO MAKE
 Boom Chains
 Logging Chains
 Skidding Tongs
 Clevis' Heavy
 Neckyokes and
 Whiffletrees

Large
 DUMPING WAGONS
 for Mill Yards a
 Specialty

ALEX. BARR

WRITE FOR PRICES Manufacturer Pembroke, Ont.



IF YOUR MILL IS NOT EQUIPPED WITH THIS MACHINE

It cannot compete with the one that is. That's plain. Why? Because

THE COLUMBIA SHINGLE MACHINE

Will produce more and better shingles, from the same stock, using the same saw kerf, and in less time, and with less power, than any similar machine on earth.

THE COLUMBIA SINGLE BLOCKER

Talk don't make this so. The machine itself proves it. It is the only shingle machine having point regulation, enabling you to get 1,000 additional shingles from every 1,000 feet of logs. Its many other points of superiority make this machine well worth your investigation if you're interested in shingle manufacturing economy. Write us.

PERKINS & CO., - GRAND RAPIDS, MICH.



Garlock Packing Co.

HAMILTON - - - CANADA

—SOLE MANUFACTURERS OF—



GARLOCK'S PACKINGS

PATENTED

Asbestos and Mineral Wool Pipe and Boiler
 Coverings, Engineers' Supplies in General

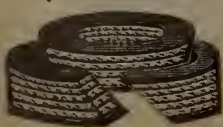

THE CANADA LUMBERMAN AND WOOD-WORKER

VOLUME XXV.
NUMBER II.

TORONTO, MONTREAL — NOVEMBER, 1905 — WINNIPEG, VANCOUVER

TERMS, \$1.00 PER YEAR
Single Copies, 10 CENTS

THE LATE MR. W. H. MURRAY.

The death of Mr. W. H. Murray, head of the firm of Murray & Gregory, Limited, St. John, N. B., which occurred at his home in that city on October 2nd, was the cause of wide-spread and profound regret. His illness extended over only a few days.

Mr. Murray, who was in his seventy-third year, was one of the oldest and most widely known lumbermen in the province of New Brunswick, as well as being prominently connected with other branches of business. He had been engaged in the lumber business for upwards of fifty years and had a very wide circle of acquaintances.

The late Mr. Murray was a native of Kingsclear, his father being the late Isaac Murray. He was educated at the public schools and at the University of New Brunswick, from which he graduated with a degree of B. A. in 1852. Soon after graduating he was appointed school inspector, but this occupation was not to his liking and he abandoned it and engaged in the lumber business with his uncle, the late Thos. Murray, who for many years operated a large saw mill at Springhill. In 1878 he acquired an interest in the mill property at Marble Cove, just above the falls at St. John, including the mill and thirteen acres of land fronting on deep water. The mill was destroyed by fire in 1876 and rebuilt in the same year. A little later the mill was again burned and on the site erected the present modern and extensive saw mill establishment. Mr. Murray became sole proprietor in 1882.

The greater portion of the output of this mill was deals for the English market, although shipments were also made to the United States and South America. The business continued to expand, and a few years ago Mr. J. Fraser Gregory, who had long acted as secretary for Mr. Murray, was admitted to partnership, and afterwards the business was formed into a joint stock company under the name of Murray & Gregory, Limited.

The capacity of the mill was slightly under twenty million feet annually, but this did not represent the extent of the firm's operations.

Their yearly cut totalled 40,000,000 feet of pine, spruce and cedar logs. Their timber holdings were very extensive, amounting to upwards of 800 square miles, situated on the Big Black, St. Francis and St. John rivers and Temiscouata Lake.

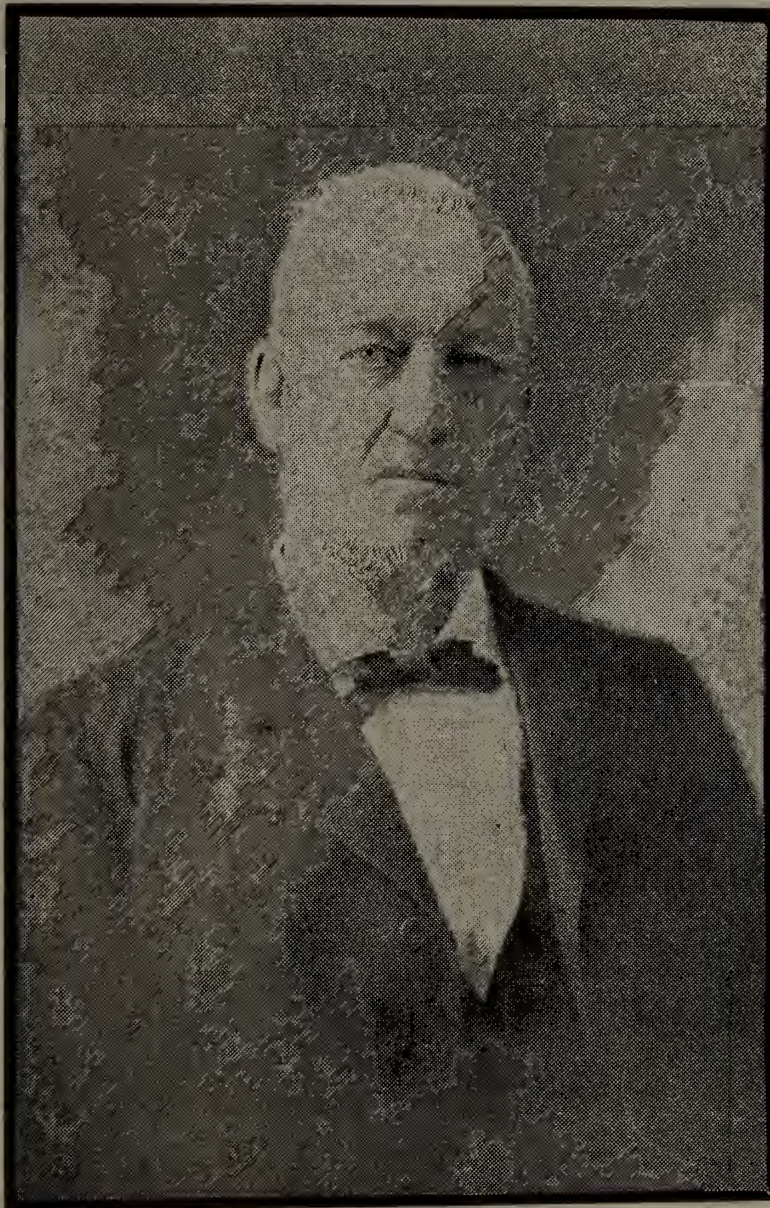

THE LATE MR. W. H. MURRAY, ST. JOHN, N. B.
By Courtesy of the St. John Telegraph.

In addition to his lumber interests, Mr. Murray was president of the James Pender Wire & Nail Company, of St. John N. B., and was interested in the St. John River Log Driving Company, the Fredericton Boom Company, the Cushing Sulphite Fibre Company, the Hartt Boot & Shoe Company, Limited, and the St. John Iron Works Company.

Few men were more highly esteemed than Mr. Murray, who, as a great captain of industry, came into contact with a large number

of people. He was a man of broad mind and generous instincts, an employer who treated his men well, a giver to the poor in no unstinted measure, and one whose word was as good as his bond. In business circles he was very highly regarded. Shrewd, energetic, quick to act, with mature judgment and pluck, he faced difficult situations and overcame them when less courageous men would have faltered and perhaps failed. Mr. Murray's estate is valued at upwards of \$600,000.

ENTERING THE SAW MILL FIELD.

The latest aspirant for saw mill honors on the Pacific Coast is Mr. J. S. Emerson, of Vancouver, president of the B. C. Loggers, Association. Mr. Emerson's mill is to be located at Greenway Sound, about 150 miles north of Vancouver, being the most northerly mill on the coast, and right in the heart of his timber limits.

The daily capacity of the mill is to be about 50,000 feet. At the time of writing Mr. Emerson is negotiating for the purchase of the necessary saw mill machinery. He will put in a fully equipped and up-to-date plant and it is his intention to extend the capabilities of the mill as business demands it. Mr. Emerson's object in locating his mill on the limits is that he may be enabled to secure a greater amount of lumber out of each tree cut. Many of the big trees, when cut down, split for a number of feet up, thereby necessitating a large amount of the very best part of the tree being cut off and left there. With the mill near by, the trees may be cut closer to the ground and all of the log utilized. Another feature in favor of Mr. Emerson's plan is

that he can bring down scows loaded with lumber much cheaper than logs can be brought down.

Asked if it would be difficult to procure men to run the mill up there, Mr. Emerson said he did not anticipate any trouble in that direction. At present he has nearly 300 men up there logging.

Charles Leon, age 54 years, was seriously injured at Fraser's mill, Deschenes, Que., by a load of lumber falling on him.

MEASURING THE HEIGHT OF TREES.*

There are several methods of determining the height of a standing tree. One of the simplest is to measure the shadow of the tree and the shadow of a straight pole of known length set perpendicular to the earth. Multiply the length of the shadow of the tree by the length of the pole and divide the product by the length of the shadow of the pole. The result will be the height of the tree.

A method used when the sun is not shining is to set two poles in a line with the tree. (See fig. 1.) From a point on one pole sight across

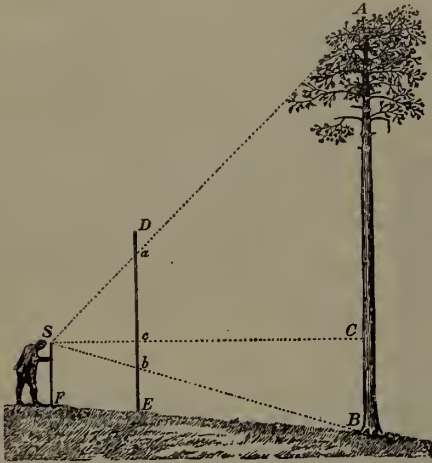

FIG. 1.—MEASURING THE HEIGHT OF A TREE BY MEANS OF TWO POLES.

the second pole to the base and to the top of the tree. Let an assistant note the points where the lines of vision cross the second pole and measure the distance between these points. Also measure the distances from the sighting point on the first pole to the base of the tree and to the lowest vision point on the second pole. Multiply the distance between the upper and lower vision points on the second pole by the longer of the other two measurements and divide by the shorter; the result will be the height of the tree.



FIG. 2.—MEASURING HEIGHT OF TREE BY USE OF KNOWN HEIGHT TO EYE OF OBSERVER.

Example: Let $ab = 6$; $Sb = 4$; and $SB = 30$;
then $\frac{6 \times 30}{4} = 45$, height of tree.

Another method sometimes used is as follows: The observer walks on level ground to a distance from the foot of the tree about equal to its estimated height. He then lies on his back, stretched at full length (fig. 2), and an assistant notes on a perpendicular staff erected at his feet, the exact point where his line of vision to the top of the tree crosses the staff.

The height of this point from the ground BC is measured and his own height from his feet to his eyes AB. Then: $AB : BC = AD : DE$.

$$DE = \frac{BC \times AD}{AB}$$

Example: Let $AB = 6$; $BC = 5$; $AD = 60$;
then $\frac{5 \times 60}{6} = 50$, height of tree.

FAUSTMANN'S HEIGHT MEASURE.

This instrument, shown in fig. 3, consists of a skeleton rectangular metal frame having two crossbars at one side of its longitudinal center, the frame and bars being in one piece. A slide, reversible end for end and having beveled edges, works in undercut grooves formed in the inner edges of the crossbars. This slide is provided at its ends with thumb notches, and with transversely arranged index marks, designated I and II. A plumb line carrying a plummet is attached to the slide in the center of the index mark II. A retaining spring secured to the back of the frame and bearing against the inner face of the slide holds it in any position in which it may be set. The left-hand end bar of the frame is furnished with an eyepiece, and the right-hand end bar with an objective, these being made of metal and hinged so as to be folded down out of the way when the device is not in use. A long, narrow mirror, hinged to the frame at a point below the objective, is furnished to reflect a right-hand horizontal scale and a left-hand horizontal scale engraved upon the lower bar of the frame, and meeting at a zero point which is intersected by a line passing through the longitudinal centre of the slide. The right-hand scale runs to 75 and the left-hand scale to 225, the latter scale extending upward on the left-hand end bar of the frame. The right-hand crossbar is provided with a vertical scale running upward from zero to 100, and continued on



FIG. 3.—FAUSTMANN'S HEIGHT MEASURE.

secured, which gives the total height of the tree. If the observer should be standing so that the level of his eye is below the base of the tree, he should first determine the height from the level of his eye to the top of the tree, then the height from the level of his eye to the base of the tree, and subtract the last result from the first, which gives the true height of the tree. Cost about \$10. (See fig. 4.)

A cheaper form of this instrument has a wooden frame and slide, and scales printed upon strips of paper and pasted upon the frame.

CLINOMETER FOR MEASURING HEIGHTS.

This instrument, shown in Fig. 5, consists of a square panel of wood recessed to receive a metal disk and a glass which protects it. The disk has a curved right-hand scale and a curved left-hand scale engraved upon it below its center. These scales meet each other at a zero point, and correspond to each other in their graduations, which run outward in opposite directions from the zero point to 100. The graduations of these scales represent percentages of angles instead of degrees of angles, as do the graduations of most clinometers. These two scales are swept by a pendulum ball, the lower half of which is beveled and brought to an edge having a central index mark. The pendulum rod is formed at its upper end with an eye receiving a movable screw stud passing through the disk and panel and terminating at its rear end in a push button.

the left-hand crossbar with a scale running upward to 175. These scales are divided in fifths and numbered. The lines forming the scales are equally separated from each other and represent units of distance under any system of measurement that may be adopted. The handle of the device is attached to the left-hand crossbar.

To use the instrument, the observer measures the horizontal distance in feet, yards, or in any other desirable unit, from where he is to stand to the base of the tree. He then sets the slide by one or the other of its two index

*Reprinted by permission from the Woodman's Hand-Book, by Henry Solon Graves, published by the Bureau of Forestry, United States Department of Agriculture.

A spring secured to the back of the panel engages with the button and draws the head of the screw against the eye of the rod, and so holds the pendulum against swinging, except when the button is pushed inward to take the tension of the spring off the pendulum, which is then free to swing by gravity when the instrument is held in a vertical plane. The disk of the clinometer, shown in the figure, also



FIG. 4.—MANNER OF USING FAUSTMANN'S HEIGHT MEASURE.

has some directions engraved upon it. The instrument is only about 3 inches square and may be easily carried in the vest pocket.

To use the instrument the observer sights along its upper edge to the top of the tree and releases the pendulum by pressing the push button. When the pendulum comes to rest over the right-hand scale, the pressure on the push button is removed, permitting the spring to act to hold the pendulum until the reading can be taken. The number now opposite the index mark is the percentage of the angle formed by a line running from the observer's eye to the top of the tree and a horizontal line running from him to its trunk. This percentage is the ratio between the height of the tree above the level of the observer's eye and the horizontal distance from the observer to the tree. This value is multiplied by the horizontal distance from the observer to the tree. The result is the height of the tree above the level of the observer's eye. The observer then sights the instrument to the base of the tree, operates it as before, takes the reading from the left-hand scale, multiplies the value thus secured by the horizontal distance from him to the tree, and adds this result to the result previously obtained, and thus secures the total height of the tree. These computations may be greatly simplified by taking all observations at a distance of 100 feet or 100 yards from the tree.

A more elaborate form of the instrument is furnished with a hinged cover to shut over the glass and with two sights located at the upper corners of the panel.

COMBINED SURVEYORS' HAND LEVEL AND CLINOMETER.

This instrument (shown in fig. 6) has a telescoping surveyors' hand level of ordinary construction, except that its spirit tube is located above instead of in its main tube, which, however, contains the usual inclined steel mirror and sighting cross wire.

Combined with the hand level is a clinometer comprising a plate screwed to one side of the main tube of the hand level and having engraved upon it a curved right-hand scale and a curved left-hand scale. These scales

are struck from the same centre and meet at a zero point, from which they are graduated outward in degrees to 90. A measuring arm, having a spatulate lower end beveled to receive vernier graduations, sweeps these scales. This arm is carried by a short shaft journaled in the upper edge of the plate and concentric with the two curved scales. The outer end of the shaft is furnished with a knurled hand wheel, by which the clinometer is operated. The inner end of the shaft carries a frame supporting the tubular case containing the spirit tube of the hand level, the centre of the case being cut away to show the bubble in the tube. A jam nut for setting the instrument is applied to the extreme inner end of the shaft, and when turned inward holds the same against turning. The measuring arm and frame are rigid with the shaft, so that when the same is turned in either direction they turn together and to the same extent, the same as if of one piece. The case stands at a right angle to the measuring arm, so that when the arm is placed at the zero point of the two scales the case will be exactly parallel with the longitudinal axis of the hand level.

A slot formed in the top of the main tube is located in line below the exposed middle portion of the spirit tube and in line above the mirror, and permits the bubble to be reflected in the mirror, which is so narrow and placed so close to the off side of the main tube that it does not interfere with the line of vision through the same and a view of the cross wire.

The hand level is often of use to lumbermen in laying out roads and trails and in locating dams. To use the instrument as a hand level it must first be set by swinging the case containing the spirit tube into line with the main

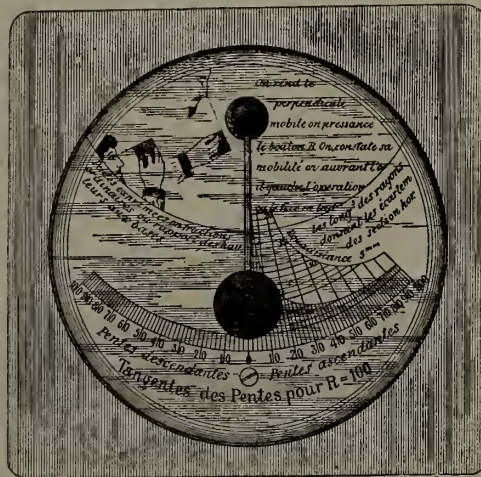

FIG. 5.—CLINOMETER FOR MEASURING HEIGHTS.

tube. The observer then sights at an object through the tube, which he brings to a level by the bubble reflected in the mirror, and then notes whether or not the object is above or below the cross wire. If the object is in direct line with the cross wire it is on the same level with his eye; otherwise the object is above or below the level of his eye, as the case may be.

The lumberman may also use the hand level in finding the height of a hill, or the height of any point on the slope of a hill, as is necessary in making topographical maps. To find the height of a hill, the observer begins at its base, and after leveling the instrument, sights in the desired direction, and notes the point ahead

intersected by the cross wire; he then advances to that point and repeats the operation, and so moves up the hill from point to point until the top is reached. As between each observation he advances a height equal to the distance from the ground to his eye, the height of the hill will be the product of that distance by the number of observations taken.

The instrument may also be used as a clinometer to ascertain the slope of a hill. To do this the observer sights the instrument at an object on the slope which is the same height above the ground as his eye and located above or below where he stands, according as he is

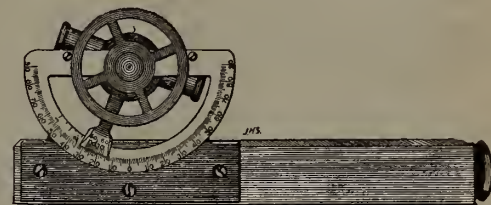

FIG. 6.—COMBINED SURVEYOR'S HAND LEVEL AND CLINOMETER.

sighting up or down the hill. He now uses the hand wheel to swing the tubular case until the bubble shows it is level. The measuring arm, which swings with the case, is at the same time swept over one or the other of the two scales, and indicates upon it the slope of the hill in degrees.

If the observer will provide himself with a table of natural tangents he may use the instrument for measuring the height of trees. He sights the instrument at the top of a tree and turns the hand wheel until the bubble shows that the case is level, at which time the measuring arm, which swings with the case, indicates upon the right-hand scale in degrees the angle formed by a line running from the observer's eye to the top of the tree and a horizontal line extending from his eye to the trunk of the tree. He then consults his table of natural tangents, which gives him the value of the angle secured, expressed as its tangent or percentage. The tangent or percentage of this angle multiplied by the horizontal distance from the observer to the tree gives the height of the tree above the observer's eye. He then sights to the base of the tree, and in the same manner ascertains the angle formed by a horizontal line running from him to the tree and a line running from his eye to the base of the tree. He now consults his table again for the value of this angle expressed as its tangent or percentage and multiplies this value by his horizontal distance from the tree, which gives the height of the tree from the ground to the level of his eye. The figures thus secured are added together, giving the total height of the tree. Cost, \$13.

The scales of the instrument are sometimes graduated in tangents or percentages of angles instead of in degrees, in which case a table of tangents is not needed.

A number of other height measures are used in Europe, but a full description of them is not given. The most important instruments are the Brandis height measure, the Weise height measure, the Christen height measure, the Klausner height measure, and the Winkler height measure.

Several instruments have been devised to measure the diameter of a tree at any desired height. They are of practical use when extremely accurate measurements of standing trees are desired, but will probably not be extensively used by timber cruisers. The names of these instruments are the Breyman dendrometer, the Winkler dendrometer (combined with the Winkler height measure), and the Wimmenauer dendrometer.

JOTTINGS BY THE WAY

The logs which are now being brought to the saw mills bear testimony in a very striking manner to the decadence of the white pine timber supply. To-day the logs in the Georgian Bay district average about fifteen to the thousand, while in the great white pine region of the Mississippi Valley twenty logs to the thousand is about the average. A gentleman who was lumbering on the Chippewa River



MILLS OF THE C. BECK MANUFACTURING COMPANY, PENETANGUISHENE, ONT.

about twenty years ago mentioned to the writer that he had bought nine million feet of logs giving nearly 350 feet each, or about three logs to the thousand. Such logs to-day would be considered objects of curiosity even by white pine operators.

* * *

For over thirty years the quantity of logs floated down the Mississippi river to Minneapolis has averaged 350,000,000 feet annually. We are told that it is estimated that ten per cent. of these logs are sunk in transit and never reach their predetermined destination. Norway logs sink easily, and through getting into bays or from other causes many white pine logs have also found their way to the bottom of the river. A conservative estimate of the quantity of sunken logs in the Mississippi river above Minneapolis would probably be one billion feet. If these could be raised they would be worth about twelve dollars per thousand, or a total of \$12,000,000. The time will doubtless come when this timber will be recovered, indeed, many propositions have already been considered looking to that end. One of the drawbacks, however, is that logging operations are still being conducted on the river. To recover the logs would doubtless involve a very heavy expense, but the venture would seem to offer a reasonable opportunity for profit.

* * *

Mr. W. King, the well known millwright, speaking to a representative of this journal recently at Revelstoke, B.C., said: "I believe two single bands and a resaw is the best system for lumbering in British Columbia. This would give a capacity of 140,000 ft. per diem. The saws will stand up to it better and will saw everything that comes. I think the gunshot steam feed is the best, especially for small timber, because it is quick. The element of danger can be eliminated if a safety valve is attached to the cylinder pipes that

drive the feed. The boiler room should be set clear away from the engine room—away from danger of fire. Dynamos should never be placed on wood or in the mill, but set up in the engine room on cement or stone foundations." Mr. King added that "a good mill always pays in the long run."

* * *

Mr. Donald Ferguson, of the Ferguson Lumber Company, London, Ont., thus expresses himself in respect to British Columbia shingles: "I have handled British Columbia shingles for years, and they are increasing

in favor constantly, but the business is being retarded by the internal dissensions of the British Columbia millmen. It is not so much the price shingles are selling at, but it is the numerous prices they are selling at. For instance, you get a circular that shingles are fixed at a certain price and you send for a large consignment. Just as they arrive, your customer comes to you and says, 'I am getting British Columbia shingles from another firm away under what you are selling for.' This means that the selling arrangement in the Pacific province is once more ruptured, and you face the annoyance of being obliged to sell at a loss, or have the other firm who has bought British Columbia shingles cheaper than you



DOCKS AND LUMBER YARDS OF THE C. BECK MANUFACTURING COMPANY, PENETANGUISHENE, ONT.

have get your business from you. This season selling conditions in the Ontario shingle trade have not been favorable. A great quantity of shingles was purchased in 1904, at the ruin prices then prevailing, for 1905 delivery, and these cheap shingles have been reaching the market throughout the present season, to the great disadvantage of those who were not fortunate enough to have ordered a year in advance."

Mr. John R. Martin, deputy timber inspector, started on his fall round of the Mountain mills on October 30th. Mr. Martin's territory covers Northeast Kootenay and all West Kootenay except Trout and Kootenay Lakes.

THE C. BECK MANUFACTURING COMPANY.

Away back in 1872, when Canada was a young nation and many of our larger cities were but little towns or hamlets, Mr. C. Beck started a saw mill in the little town of Penetanguishene, on the southern shore of the Georgian Bay. Since then many other mills have sprung into existence along those shores, but the little mill of C. Beck kept pace with the times and year by year increased its capacity and output until now it ranks amongst the larger mills in Ontario.

The plant now stretches three-quarters of a mile along the shore of the bay, covering in all about 100 acres. Two saw mills are in operation here, the new Keene mill, containing two modern band saws, and the Penetang mill, with a circular and gang saw, planing mill and box factory. The company also have a shingle mill in operation here, also a large tub and pail factory. In addition to this they have a box factory in Toronto which consumes upwards of three million feet of lumber annually.

The number of hands employed in their mills at Penetang averages 275. The annual lumber output is about twenty million feet and two hundred and fifty thousand boxes. Two tug boats, the "C. W. Chamberlain" and the "Wahnapitæ," are in use hauling the company's logs.

The timber limits owned by the Beck Company are scattered over the north shore of Georgian Bay and through the Algoma, Nipissing and Parry Sound districts, also out in the Rainy River district and other parts of the North-West.

The present company was incorporated in 1889, under the name of the C. Beck Manufacturing Company, with C. Beck president, and J. F. Beck secretary and treasurer.

CONCERNING BRITISH COLUMBIA.

Mr. Geo. A. Gall, the British Columbia representative of this journal, is now making

a tour of that province for the purpose of visiting the saw and shingle mills, studying the conditions of the trade, and securing as subscribers the few manufacturers who are not already on our list. The CANADA LUMBERMAN has now a large circulation in British Columbia, but it is our desire that the journal should reach regularly every mill in the province, and to this end our efforts shall be directed. The Vancouver office is located at 536 Hastings street.

Mr. W. F. Gurd, of Cranbrook, B. C., has resigned as the secretary of the Mountain Lumber Manufacturers Association and has been succeeded by Mr. Geo. P. Wells, of Nelson, B. C.

CORRESPONDENCE

LUMBER INSURANCE.

HILLSDALE, ONT., Oct. 11, 1905.

Editor CANADA LUMBERMAN :

DEAR SIR :—Replying to yours asking for our opinion on the high rates of insurance we have to pay and how it can be reduced. Our opinion is that insurance companies have lost so much money of late years that unless the company gets a high rate they would go under. The point is how can the risk be made safer for the company which is carrying it. The answer would be to make the mill safer from fire. How can we do this?

Mills usually take fire from some internal cause, either from a hot bearing or from the boiler house or a spark from the smoke-stack. We think a large percentage of mills take fire from the boiler furnace, the sawdust leaking out from the conveyors which feed the furnace with sawdust, and the conveyors being usually close to the stack or smoke box which conveys the smoke to the stack, thus making the dust ready to take fire. Under the ordinary way of building furnaces and feeding the sawdust in, there is always an escape of sparks. The opening of the furnace doors will often cause sparks to come out of the feeders, and if not seen in time, set fire to the mill, and we know the result to our sorrow. A properly constructed furnace should be as safe as a stove.

The writer was in a large mill not long since, just after 6 p.m., and looking through the boiler house saw smoke coming out through the spouts which let the sawdust down from the conveyors. In looking around for the cause of the smoke, I noticed that the watchman had opened the door at the end of the boiler where the tubes are cleaned, thus cutting all the draft off from the smoke-stack. The shutting off of the draft from the furnace in this way does not prevent the sawdust from burning in the furnace, and where would the sparks and smoke go but out of the furnace and on the dry dust around the spouts, and overhead. Many watchmen do this so as to make the fire hold out and thus keep the steam up without putting any fresh sawdust in the furnace. We think that the draft from the stack should never be entirely cut off from the furnace. There should always be enough draft to take the smoke and sparks, and if there is a damper in the stack or smoke-box it should be opened enough to draw the smoke and sparks off. The watchman will say that the steam will rise and blow off and waste the water—well, put more water in and let the steam blow, rather than run the risk of fire.

The furnace in our mill at Hillsdale was constructed so that the inspector of the company we insured in gave us $1\frac{1}{4}$ per cent. less than the usual tariff rate. Had it not been for the way the furnace was constructed, the inspector would not have insured it at all, on account of it being a shingle and lumber mill combined.

We think the only solution is to make the risk right and safe, then the insurance companies would be safe and able to give a low rate.

Yours truly,

WM. COOKE & SONS.

TIMBER SLIDE COMPANY'S ACT.

TORONTO, Oct. 25th, 1905.

Editor CANADA LUMBERMAN :

DEAR SIR :—Following my last letter I beg to suggest amendments to the Timber Slide Company's Act to be laid before the Minister of Lands and Mines.

The late Hon. A. S. Hardy made a ruling on this Act which has resulted in much loss. He decided that the expense of management and the sinking fund must be spread over all sections, whether operated or not. Consequently the company could only collect a part of this expense and sinking fund from those sections which were used. The rest was charged to the unused sections, and as nobody paid it, it was never recovered.

This distribution of the sinking fund over each

section also gave much trouble and caused much loss. Each section originally cost a certain amount and the sinking fund to replace that sum had to be earned by that section. But if it was not used, there was no return, and consequently no sinking fund was provided and the company never got it back.

To illustrate the hardship to the company of this method of dealing with expenses and sinking fund, take a company with 10 sections, costing \$500 a section. If the expenses of one year in operating the company were \$50.00 — and the sinking fund, (spread over the number of years the company was to last, say 10 years) was say \$45.00, then each section would be charged \$95 a year. If after five years only five sections were operated and produced a revenue, then for the last five years the remaining five sections would produce nothing and the company would be out \$475.00 each year.

The difficulty is to provide for this amount, because the lumberman who used only the five sections would not expect to pay this loss. The fact is that the Act was originally drawn when all the sections of a stream were used during the life of the company and cannot produce a fair result when only part are operated.

The theory of the Act is that the whole original expenditure and the repairs and the cost of management shall be repaid with interest when the company's charter expires. The Act needs to be entirely remodelled. The streams operated are longer and serve a greater area and as side streams are improved or limits are cleared up many sections become useless.

The sections to be dealt with are 21, 40 and 43—section 21 provides for the annual statement of receipts and expenditures of the company and an estimate of the proposed improvements and of the number of logs to come down.

Sections 40 (in part) reads as follows:—"40. The tolls for the first year shall be calculated upon the estimates herein before required to be made of the cost of the works, and the quantity of different kinds of timber expected to pass down the stream, and the tolls in all future years shall be calculated upon the cost of the works and the quantity of different kinds of timber expected to pass down the stream, and the receipts and expenditure, according to the accounts of the then next preceding year, as rendered in accordance with the provisions of section 21 and the following sections of this Act; and the tolls shall be so calculated that, after defraying the necessary cost of maintaining and superintending the works and running, driving, booming, towing, sorting and rafting logs and other timber, and providing an equal annual sinking fund, which invested at six per centum, shall be sufficient to pay back to the shareholders the amount of their paid-up stock at the end of the time limited for the existence of the company and collecting the tolls, the balance of the receipts may as nearly as possible be equal and in no case exceed \$10 for every \$100 expended and invested in the said works."

Section 43 (in part) reads as follows:—"43. The annual account required to be rendered by every company shall contain a schedule of the tolls calculated as aforesaid, which it is proposed to collect in the following year, which schedule shall be published in the manner provided by section 9 hereof prior to the first day of March in each year."

The necessary amendments suggested are as follows: Add to section 21:

11. A statement and description of any sections of the works which it is believed will not produce tolls during the current year and of the amount of the sinking fund and cost of office charges relating to superintending the works properly attributable to each.

12. A statement of the surplus received over the expenditures actually made during the past year and

the sinking fund required in such year or of any deficiency actually occurring.

Add to section 43:

"And in fixing the schedule of tolls it shall be lawful for the company to charge such an amount as will provide for the raising of the sinking fund and the cost of the office charges relating to superintending the works which it is estimated will not be produced from those sections which are not likely to produce any tolls during the year provided such amount and a description of the non-producing sections are specified in the return required to be made under section 40 of this Act.

This amendment will enable the Commissioners of Crown Lands to deal equitably with both the company and the lumbermen using the stream.

Section 50 also requires amendment. It only provides for a penalty of \$10 for resisting or impeding the company in its operations. This is quite insufficient, nor does it take into account the loss to the lumbermen themselves who may be seriously damaged by the obstruction, as for instance the breaking of a boom, or the destruction of a dam.

The following amendment to section 50 is suggested:

After the words "Molest the company or its servants in the exercise of any rights secured to them by this Act" insert the words "Or shall interfere with or damage any of the works, dams, piers, slides, booms or any chain or other fastening attached thereto or any raft, crib of timber or sawlogs or impedes or blocks up any channel or passage intended for the transmission of timber."

Instead of the words "a fine of not more than \$10 nor less than \$1.00" insert "a fine which shall equal the actual loss or damage occurring to the company."

And add to the section:

"And if by reason of such wrongful act any person or corporation using any of the works of the company or its property as aforesaid or doing any act in relation thereto with its permission suffers damage, such person or corporation shall have an action against the person doing such wrongful act to recover such damage in any Court of Competent Jurisdiction."

FRANK E. HODGINS,

103 Bay Street, Toronto.

TIMBER CULLERS.

According to the last report of the Commissioner of Crown Lands for Ontario, cullers' licenses have been issued to 1,062 persons residing within the province.

CASUALTIES.

A logger named James Allen was killed by a falling tree at Howe Sound B.C., the tree being blown down during a wind storm.

L. Croft, a logger employed at the Monarch Company's camp at Port Renfrew, B.C., was struck by a wire cable used for hauling logs and seriously injured.

A bad accident happened to Thomas Muise, jr., at Murchie's mill, Deer Lake, N.B. He was employed at the carriage of the rotary saw, when through a mishap and to save himself from a fatal accident, he jumped over the moving saw, which severed his right leg below the knee.

Finley Shortreed was killed on the logging road of the British Columbia Mills, Timber & Trading Company's Rock Bay camp. He was conductor of No. 6 logging train, which was derailed by a misplaced switch. The deceased was crushed between the logs and drawhead and died about two hours later.

William Burke, foreman in the Shepard & Morse mill at Bayswater, Ont., had his left hand so badly injured by a saw that amputation was found necessary. He was inspecting the saw which was not turning out good work and undertook to measure the boards by a piece of scantling. The stick which he held drew his hand to the saw.

The William Hamilton Manufacturing Company, of Peterboro, Ont., have recently supplied steam tension band mills for the Colonial Lumber Company, Pembroke, Ont., and the Small & Bucklin Lumber Company, New Westminster, B.C. These are double cutting mills. They have also secured large orders for machinery from The Northern Pacific Lumber Company, Barnet, B.C., and the Victoria Lumber & Manufacturing Company, Chemainus, B.C.

THE Canada Lumberman AND WOOD-WORKER

Monthly and Weekly Editions—One Dollar Per Year.

PUBLISHED BY

The C. H. Mortimer Publishing Company
of Toronto, Limited,

CONFEDERATION LIFE BUILDING, TORONTO.

BRANCH OFFICES:

38 ALLIANCE BUILDING, MONTREAL.
720-721 UNION BANK BUILDING, WINNIPEG.

Telephone 1274

22 GREAT ST. HELENS, LONDON, E. C.
536 HASTINGS STREET, SUITE 3, VANCOUVER, B. C.
Telephone 1943

The LUMBERMAN Weekly Edition is published every Wednesday,
and the Monthly Edition on the 1st day of every month.

TERMS OF SUBSCRIPTION:

One Copy, Weekly and Monthly, One year, in advance, \$1.00
One Copy, Weekly and Monthly, Six Months, in advance, 50
Foreign Subscription, \$2.00 a Year

ADVERTISING RATES ON APPLICATION.

THE CANADA LUMBERMAN AND WOOD-WORKER is published in the interest of and reaches regularly persons engaged in every part of Canada in the lumber, wood-working and allied industries. It aims at giving full and timely information on all subjects touching these interests, and invites free discussion by its readers.

Special care is taken to secure for publication in the WEEKLY LUMBERMAN the latest and most trustworthy market quotations throughout the world, so as to afford to the trade at home and abroad information on which it can rely in its operations.

Advertisers will receive careful attention and liberal treatment. For manufacturing and supply firms wishing to bring their goods to the attention of owners and operators of saw and planing mills, wood-working factories, pulp mills, etc., the CANADA LUMBERMAN AND WOOD-WORKER is undoubtedly the most direct and profitable advertising medium. Special attention is directed to "WANTED" and "FOR SALE" advertisements, which are inserted in a conspicuous position on front page of the Weekly Edition.

IMPORTANT WORK FOR THE FOREST SERVICE.

The United States Forest Service, formerly known as the Bureau of Forestry, has agreed to co-operate with the lumber trade to accomplish two very desirable purposes, namely, the collection of annual statistics and the adoption of a system of standard grades. This co-operation has been secured through The National Lumber Manufacturers' Association and is another indication of the great usefulness of lumber organizations, of which, unfortunately, there are too few in Canada.

The collection of yearly statistics relative to the lumber industry of the United States has heretofore devolved upon private enterprise, and for that reason they have not been sufficiently accurate and complete to be of much benefit to the trade. The co-operation of the Forest Services with the different lumber associations will doubtless accomplish much better results than in the past and admit of the publication of statistics which will be of almost incalculable benefit to the lumber industry.

A subject of equal importance is uniform lumber grades. The Forest Service is not expected to compile a system of standard grades, but simply to make such a compilation of the grades now in use as will be of service to lumber producers and consumers. The information thus obtained, however, is certain to be of value in eventually preparing the way for a standard system, which is doubtless the object hoped for.

The important work above referred to should appeal very strongly to Canadian lumbermen. Our position does not compare favorably with the United States in either statistics or grades, and when the new order of things is in vogue we will be at a distinct disadvantage. It may be said that no attempt is made by the lumber trade to secure statistics relative to the annual cut and shipments of all kinds of lumber,

stocks held at the mills, etc. But the need of uniform inspection is still more apparent. In the United States certain rules are recognized in certain districts, but in this country even this much has not been accomplished. The result of such a condition is that foreign buyers prefer to place their orders with United States firms, who can at least furnish some basis of inspection.

A TIMBER FAMINE.

Hon. Arthur Hill, of Saginaw, Mich., has conducted extensive lumbering operations in both the United States and Canada. His knowledge of the timber resources of the two countries obtained through practical experience has been supplemented by a careful study of economic conditions. Few men are better able to estimate the available supply and probable demand. His prediction, therefore, that we are approaching a lumber famine cannot be subjected to criticism as being the expression of a theorist, but must be recognized as a plain and well considered statement concerning a subject of vital interest to the country. Mr. Hill has observed, as have many others, that notwithstanding the increasing use of steel, cement, etc., in building operations, the demand for lumber has not diminished, but on the other hand is steadily growing larger. Lumber that twenty-five years ago graded as mill culls and sold at \$4 per thousand feet is to-day bringing between \$20 and \$30. The rapidity with which the timber of North America has been cut down and consumed is indeed startling, although seemingly only recognized in very recent years.

The annual consumption of timber in the United States has been estimated at fifty billion feet, while taking the same basis for calculation, namely, 650 feet per capita, the consumption in Canada would be about four billion feet, or a total domestic consumption for the two countries of fifty-four billion feet. But this figure does not represent the full extent of the demand upon the timber supply. The products of the forests of North America are being exported to all parts of the world. Considering the vast quantity of timber which is each year required for the domestic and export trade, Mr. Hill's prediction comes as a timely warning.

The lumber manufacturer is directly interested in the question of timber supply. With the approaching exhaustion of the great white pine belt, the tendency of stumpage values has been to increase. This tendency is almost certain to continue and values be established far above the present for all kinds of timber. Many manufacturers are owners of limits. A question to which they should give consideration is whether more money could not be made by preserving their timber areas to a greater extent than in the past. It is not expected that lumbermen, engaged in that branch of industry as a business, will recognize any claims on behalf of a timber supply for future generations. Necessity demands that their mills shall be employed during the sawing season, their customers retained, and their business kept in tact. Conservative operations,

however, would seem to be the part of wisdom. The crowding of mills with the object of reaching the maximum of production does not always mean large profits, a statement to which emphasis should be given as the timber supply becomes less plentiful.

ARE THE HARDWOODS OVERLOOKED?

The building season now drawing to a close has doubtless been the most active in the history of this country. The three largest cities, Montreal, Toronto and Winnipeg, each show a substantial gain over last year in the value of permits issued, and much the same conditions exist at other places. Lumber for building purposes has been consumed in enormous quantities.

White pine is still the favorite finishing wood, and influenced by the heavy demand for building purposes in late years, prices have advanced to a high basis. Hardwoods, on the other hand which are also used to some extent for finishing material, have made little progress, and prices are to-day lower than a year ago. The explanation of this seems to be that hardwoods are lacking in popular favor owing to common ignorance of their qualities. Architects have become so accustomed to specifying pine finish that they give little or no thought to the substitution of other woods which might answer equally well and at considerably less cost.

Among the hardwoods to be found in this country, birch is predominant. This wood is now used largely for furniture making and flooring, but for finishing purposes has not been employed to any extent. There is no reason, however, why it should not be so employed, as it has a pleasing color and clear grain and when properly stained its appearance is greatly enhanced. That birch has been in greater demand this year than the other hardwoods may be the beginning of a wider recognition of its many advantages.

Basswood has been extremely inactive all season and shows a marked decline as compared with, say, two years ago, but for reasons which are not far to seek. The price was carried up beyond a legitimate value, substitution followed, and the market thus lost has not yet been recovered. But basswood is a splendid lumber for many purposes and should soon regain its former position.

The hardwood trade of Canada is yet only in its infancy. There are great possibilities for the industry, and as our manufactories increase in number so will hardwoods increase in consumption and value. Allowing for stumpage, logging, manufacturing and marketing, there is little profit in producing hardwoods at the present time, but the intrinsic worth they represent will be recognized in later years.

A Canadian concern, finding no special machines on the market for the manufacture of meat skewers, is building a set of machines of its own invention. The machines which make the skewers used in the United States are owned by a company which prefers to sell the product rather than the machines, hence the machines are not in the market.

BURNING SAWDUST.

I see an inquiry from a Spanish reader in regard to burning sawdust, and as I am a native of the lumber district of the State of Michigan I might help him out by telling him how it is done there. At the place I come

sawdust along the bottom of the trough. This arrangement is put over the top of the boiler arches and fastened; then holes are cut in the bottom and a piece of pipe or chute made of heavy iron is put in to carry the sawdust down to the firebox. These chutes should

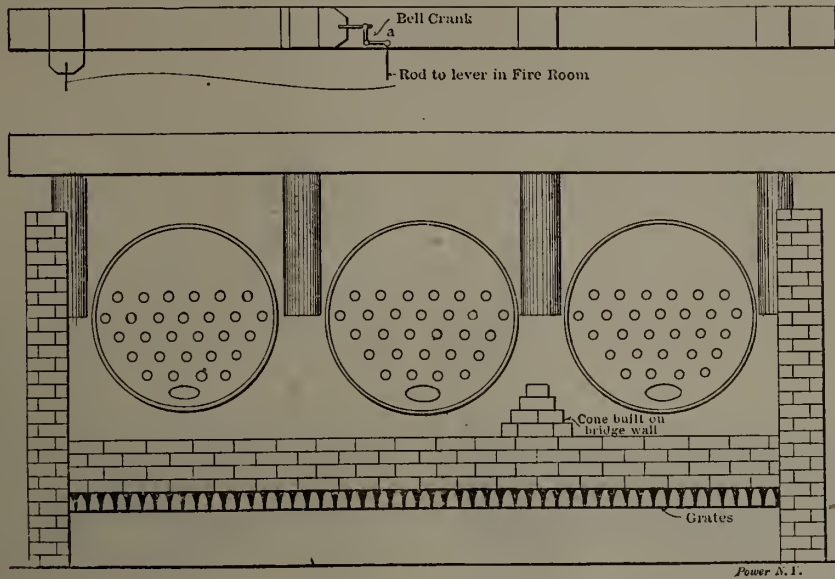

BURNING SAWDUST.

from sawdust is worth 35 cents per wagon load for ice-packing purposes. The logs there are cut in the winter and rolled into the river during the months of March and April and floated to the mills and sawn into lumber during summer, so they lie in the water from ten days to eight months.

The kind of timber is pine, hemlock, maple, beech, birch, ash, elm, and basswood. They are all good for fuel, but the conditions have to be the best to get steam with elm and basswood sawdust. The boilers mostly used are 5 feet in diameter, 16 feet long, with 4-inch tubes, set one, two and three in a battery, sometimes separated by a wall but better all in one arch and connected to a common steam dome and common mud drum, as this method lessens the care of fires and water. The proportion of grates is 36 square feet to the boiler. With grates 6 feet long and placing the boilers one foot apart this can be secured. This also allows the sawdust feeder to come down between the boilers. The grates should have 40 or 50 per cent. of opening and should be set about 26 or 28 inches below the boilers at the fire-door end and 3 or 4 inches lower at the bridge wall. The bridge wall should be about 8 or 9 inches from the boiler, and cones or pyramids built on top of the bridge wall, as shown in the sketch, between the boilers, sometimes help their steaming qualities. A second bridge wall should be built at the back end of the boiler and the space between the two filled up and payed over with brick. When cones are used it is not necessary to build them all the way back. A liberal stack should be used and a good draft secured. I have gotten good results from a boiler with a draft 9-16 inches of water at the base of the stack, but this was not considered a good draft. In these mills the firing is done with a chain conveyor. An iron trough is built about 12 inches deep and 16 or 18 wide, through which is run a double line of sprocket chain, to which are riveted angle-iron buckets which drag the

be as wide as the conveyor and 8 or 10 inches the other way, and should come down to the bottom of the arches at the sides and between the boilers. A slide should be provided to close the chutes. This should be fastened to the bottom of the conveyor and made to open the chute all the way across the conveyor rather than from the side. Long levers for operating these slides are hung from framework down in front of the boilers in easy reach of the fireman, and are connected to the slides by means of rods and bell cranks. The method

the centre of the grates. The dust should be left as it falls into the fire and not barred nor spread around. It will pile up and roll down until it meets under the boiler. It should then be banked up against the bridge wall a little, but should not quite reach out to the firedoors. The fire and flames will then come up at the front and go over the top of the dust and give a good hot fire. If the fire is open at the bridge wall the flames will be short and small amount of fire is all that can be got. Care should be taken not to get too much dust in so it will roll down against the fire-door, as this would smother the fire. The slides should be so set as to supply the dust as it is burned, which can be done after a little practice. Never attempt to burn slabs or chunk wood with sawdust. Use wood to start with, then build up sawdust fire slowly. When the edges of the fire have met under the boiler the fires are generally at their best. I have known cases where the back of the grates had to be covered with brick in order to get the fire to burn at front. I have also seen 5x16-foot boilers give good results with only 28 square feet of grate surface, but they were not good to handle, as the fires would burn out so quickly if the dust stopped coming for a few moments and this meant some hand firing. —"J.W.M." in Power.

LOSS IN LOG DRIVING.

In connection with log driving a question has been presented to the readers of The Paper Trade Journal which is quite interesting in a way. It is this: What percentage of logs is lost in sinking from being waterlogged during the drives covering a two year cut? Estimates have been made by river men and loggers



From Bulletin No. 34 U. S. Bureau of Forestry.
THE LARGEST MILL IN THE STATE OF NEW YORK, OPERATING TWO GANG SAWS, TWO BANDS AND TWO CIRCULARS.

shown at *a* is the better, as each slide would be the same distance open to supply fires, whereas in the other case the first slide would be about 2 inches open, the next 4, the next 6, etc., and the large opening would let a lot of cold air into the fire which would be detrimental. The conveyor and chutes should be so set as to deliver the sawdust a little back of

all the way from 5 to 20 per cent. If someone with authority can give some definite information on this question a number of Canadian pulp manufacturers will be pleased to hear from him.

Major Woodridge is rebuilding his saw and planing mill at Palmerston, Ont.

WESTERN CANADA

Western Offices of The Canada Lumberman,
720-721 Union Bank Building, WINNIPEG, MAN.; 536 Hastings Street, VANCOUVER, B. C.

ENERGETIC OFFICERS OF A LUMBER COMPANY.

We have much pleasure in presenting on this page portraits of the officers of the Red Deer Lumber Company of Winnipeg. The officers are as follows: O. A. Robertson, president and general manager, St. Paul, Minn.; F. G. Barrows, vice-president, Fergus Falls, Minn.; W. B. Tomlinson, treasurer and sales manager, Winnipeg, Man.; F. B. Lynch, Secretary, Red Deer, Sask. The officers are also connected with the Elk Lumber Company, of Fernie, B.C., whose mill was recently burned down, entailing a loss to the company of over \$100,000. We understand, however, that they have decided to rebuild at once.

The Red Deer Lumber Company have their mills at Barrows, Sask., on the shore of the Red Deer lake. On the first of the year the headquarters of the Red Deer Lumber Company will be transferred from Winnipeg to Barrows.

THE NEW WESTMINSTER EXHIBITION.

The Dominion Fair at New Westminster, B. C., which closed on October 7th, was an eye-opener. Not even the officers of the Royal Agricultural and Industrial Society, under whose auspices the first Dominion Fair west of the Rockies was held, fully realized the vast resources of Western Canada until they saw the exhibits all together.

Two magnificent buildings have been erected on the Fair grounds this year—one the Administrative and Industrial Building and the other the Manufacturers Building. The old Main Building had been moved to a new site and thoroughly renovated. In this building were placed all the agricultural exhibits, and they practically took the whole building.

In the Manufacturers building, which is a U shaped structure running back 140 feet with a front elevation about 160 feet, were located many exhibits, nearly all of these, however, being the products of Eastern firms in charge of their local agents.

The only electrical manufacturing firm exhibiting was the Canadian General Electric Company, who had on display induction motors and direct current generators, electric heating apparatus and supplies.

The Canada Foundry Company had a line of steam and power pumps, one of the latter being operated by a C.G.E. induction motor and supplying water for a miniature water fall, which proved a great attraction, especially as it was one of the few exhibits in motion.

The Gurney Foundry Company, through their local agents, T. J. Trapp & Company, had a splendid display of stoves, ranges and boilers. The Gurney "Bright Idea" and "Oxford Comfort" boilers were particularly

noticeable and favorably commented upon. The Chapman Double Ball Bearing Company, through their Winnipeg agents, Messrs. Gowan & Company, had on exhibit a goodly number of pulleys, bearings, etc., showing the advantages of their bearing. A feature of this display was a 115/16 line shaft, twenty feet long, driven by an ordinary cotton thread for belting, motor power being supplied by a small fan

two machines, Messrs. Letson & Burpee showed a full line of salmon canning machinery and a large assortment of mill supplies, bearings, link belting and Reeves wood-split pulleys, they being the B.C. agents for the latter.

A interesting display, and about the only one in the way of a lumber exhibit, was a small "corner in shingles," where there was on ex-



MR. O. A. ROBERTSON, Treasurer and General Manager.



MR. W. B. TOMLINSON, Treasurer and Sales Manager.



MR. F. G. BARROWS, Vice-President.



MR. F. B. LYNCH, Secretary.

OFFICERS OF THE RED DEER LUMBER COMPANY.

motor. Mr. Gowan reports great success with this bearing in the west.

One of the best displays was that of Messrs. Letson & Burpee, of Vancouver. A "Simplex" shingle machine, all iron frame, the first of that design, was shown in operation. A shingle saw re-grinder by which the grinding is done by a grindstone instead of an emery wheel, was also shown in operation. Both of these machines represent a stride forward in the perfecting of saw mill equipment. Besides these

hibition a few bunches from a number of firms, including the Serpentine Lumber Company and the Brunette Saw Mills Company of New Westminster, and the British Lion Milling Company of Hazelmere, B.C. A feature of these bunches was the large number of 20 inch shingles (full width of the bunch) in the lot. That of the Serpentine Lumber Company did not appear to contain a solitary shingle less than 20 inches wide.

It is to be regarded that the lumber industry

the chief one of the province—was little represented. It is true that not very attractive exhibits can be evolved from the ordinary output of a saw mill, and yet united effort and energy on the part of the lumbermen would likely have resulted in something of interest.

Messrs. Gilley Bros., local agents for Rosebank lime, the B.C. Pottery Company and the Vancouver Portland Cement Company, had a display of tile and drain pipes and other clay products, also specimens of "Vancouver Brand" cement.

The Vanstone Heating and Plumbing Company had an interesting display of bathroom fittings. Their display of Vanstone water tube, hot water heaters received a good deal of attention. Messrs. Hardman & Bryson also had two bath rooms fully equipped and a display of supplies, fittings, etc.

Messrs. Cope & Frey, of Vancouver, and T. Mowbray & Company, of New Westminster, had a united display of electric fixtures, electric heating devices, and electric novelties. The British American Paint Company showed a full line of Elephant brand and Ironide paints and Creosote stain, "the great shingle preserver."

Just outside the Industrial building was a unique display in the shape of wire wound wood stave pipes, manufactured by the Pacific Coast Pipe Company of Vancouver. A six inch main of this pipe is laid round the exhibition grounds providing ample water for fire, protection and water supply for all the buildings. This pipe is connected direct with the city mains and is under a pressure of 199 lbs. During the fair the trench was opened near the entrance of the Industrial building, showing the pipe as it is in the ground and giving a practical demonstration.

Looking across the grounds towards the Agricultural Hall, the eye beheld a sight that suggested a demonstration of quick work by some hook and ladder company of firemen. On closer examination it was found to be the display of automatic locking extension ladders, made by the Alright Extension Ladder Company of Vancouver. This ladder is the latest invention of Mr. Waggoner, the inventor of the ladder made by the Waggoner Ladder Company of London, Ont. Mr. Waggoner is forming a company in Vancouver to manufacture his latest patent, and to be known as the Alright Extension Ladder Company.

One display that probably called forth more favorable comment than any other was that of five ready-made houses manufactured by the B.C. Mills, Timber & Trading Company. The houses, which were put together under the direct supervision of Mr. E. C. Mahoney, the inventor of them, were in various stages of completion, thereby enabling the visitors to see exactly how the houses are constructed and what goes into them. One of them had been fully finished and completely furnished and fitted up by the Hudson Bay Company.

—The Sussex Lumber Company, Limited, Elkmouth, B. C., has been succeeded by McInnis & Puttle.

—The Independent Lumber Company, Limited, have acquired the business of the Anderson Lumber Company, Halbrite, N. W. T.

MR. E. S. HOWE.

The three saw mills belonging to the East Kootenay Lumber Company, of Cranbrook, B.C., have already been described in these columns, and in a recent issue we published a portrait of the general manager of the company, Mr. Archibald Leitch. We are now permitted to show the portrait of the secretary, Mr. E. S. Howe, who is in charge of the sales department and is one of the best posted younger lumbermen in British Columbia.

WESTERN CANADA'S PULP RESOURCES.

By Wm. Shannon.

The Dominion of Canada is claimed by experts to have the largest supply of pulp timber of any country in the world, and no part of the Dominion is so favorably situated for the manufacture of pulp and paper as is British Columbia.

The climate of the Coast is moist and without frost; this is a very essential point in the manufacture of pulp, thus allowing the mills to run the year round. There is no part of the



M. E. S. HOWE,
Secretary East Kootenay Lumber Company, Cranbrook, B. C.

world that has such great water power available as our Western Coast, which also has hundreds of miles of inland waters which the largest vessels afloat can safely navigate. Our timber is far superior to any to be found elsewhere in the Dominion.

The Douglas fir—the great lumber timber—disappears as we go north of Queen Charlotte Sound, and the spruce, one of the best pulp timbers, takes its place. As pulp timber, we have spruce, and a timber which is similar to spruce, commonly called larch, also white fir and hemlock, and in the Interior there are cottonwood and poplar, which make the cheaper grade of pulp. Although the Coast is rough and broken with mountains, still the timber can be taken out cheaply, especially for pulp purposes. There are many places that would be difficult to get logs out of, for lumber purposes, owing to the steepness of the ground, but pulp timber which is cut into cordwood could easily be run out by flume to the water; therefore our Coast timber, from its location and its quality, is more suitable for pulp purposes than for lumber. Looking over the estimates of experts, as to the number of cords of pulp timber per acre, in Ontario we find the

average about 13, and this is well known to be a correct estimate. A conservative estimate on our Coast would place it at 35 cords of pulp timber to the acre. Our timber is of a softer character and therefore easier worked.

The following figures obtained from the Japanese Custom House returns serve to show the enormous growth, in two years, in the quantity of wood pulp imported to Japan alone. During 1901 a little over 3,000,000 "kin" (equal to 4,000,000 lbs.) of wood pulp was imported into Japan. In 1903 this was increased to 12,125,560 "kin" or 16,167,413 lbs., representing a value of \$313,569,700. Of this Canada's share amounted to 141,219 lbs., valued at \$16,946.35. We may look to China and Japan as our principal future markets, as there is no suitable timber in those countries for pulp. They will no doubt import most of their pulp from this Coast and with cheap labor manufacture the paper themselves.

It is well known that there is no pulp wood in Australasia and already there is a large quantity of paper and pulp being shipped from this port (Vancouver) to those parts each month.

In 1900, the amount of pulp and pulp wood shipped from Canada to the States amounted to \$1,500,000 in value, and since then the annual export has more than doubled.

Mr. John McFarlane, of the Canadian Paper Company, reports as the result of his observations in England and Europe recently, that Great Britain and the Continent form a market that will stand at least half a million tons of Canadian pulp per annum.

It is to be hoped that the Government will devise such measures as will enable the location of pulp lands in such a way that the industry may prosper, and still safeguard the public interest.

Vancouver, B. C., September 20th, 1905.

THE REVELSTOKE LUMBER COMPANY.

Arrangements for the reconstruction of the Revelstoke Lumber Company's mill at Big Eddy, near Revelstoke, B. C., have been completed and a start was made last month by laying out the mill site. The order for the machinery equipment of the mill has already been placed with Mr. H. B. Gilmour, British Columbia agent for the Waterous Engine Company, of Brantford.

The equipment will include an eight foot double cutting band mill and Waterous steel carriage; a 54" Big Champion edger which will edge cants 8 feet thick; all live rolls and automatic transfers; a five saw overhead slab-slasher; trimmers, lath mill and bolter.

They will bring logs to the edge of mill with 300 feet centre log chain, the log in the mill will be handled on live rolls so as to cut logs in two while in the mill with a steam jump saw. It is the intention of the company to do all their logging into 32 foot logs or longer, these to be cut in the mill into required length before sawing. This is the only mill in British Columbia equipped this way.

Power will be derived from four boilers each 60 in. x 16 ft. long, of 85 h.p., and a pair of Waterous Tangye bed engines of 300 h.p. The

huge burner will be behind a rock bluff 350 feet away from the mill.

The Revelstoke Lumber Company are also building a blacksmith and machine shop combined. They are putting in a large planing mill in connection with their saw mill. All the machinery in this will be of the latest improved design. It is the intention of Mr. Chas. F. Lindemark, the managing director, to have one of the best equipped mills in America. The company have extensive limits of about 45 square miles, mostly cedar, spruce, fir and white pine, all adjoining the Columbia river on which the mill is built.

ACCOMODATION FOR MILL EMPLOYEES.

An interesting feature of the magnificent plant of the Pacific Coast Lumber Company at Vancouver is the way they look after the welfare of the Asiatic labor. Two large boarding houses, one for the Chinese and the other for the Japanese, have been erected on Georgia street, one on each side of the Company's handsome office building. A beautifully kept lawn lies between the office building and the boarding houses, where exquisite flower beds in different designs are laid out. The name of

rooms, including a plunge bath. The next flat is used for bed rooms and school room. The latter room is well arranged for the purpose for which it is used. Special teachers are employed and lessons are given three times a week. The subjects taught chiefly are reading, writing, arithmetic, and English. On Sundays the religious welfare of the intimates is looked after by local religious bodies. The top flat is occupied altogether by bed rooms, a peep into the bed rooms revealing conditions not unlike what may be seen in any of the rooms of young men who are boarding. Nice clean beds are provided, and on the wall could be seen pictures and other bric-a-brac dear to the heart of the intimates.

The boarding houses are rented entirely to one man, an Oriental, who then boards the employees of the mill at a nominal figure.

The scheme is meeting with much success and the Pacific Coast Lumber Company are to be congratulated on the way they have provided for their employees.

TIMBER RESOURCES OF BRITISH COLUMBIA.

The timber resources of the province of British Columbia are very instructively and

754,560 acres, but this must not be taken as all of present commercial value, as much of it is covered with small trees, only fit for fuel and local lumber, which would not be considered as 'timber' by the loggers.

There are over 100 sawmills in the province, big and small, with a combined daily capacity of over 2,000,000 feet, but this limit has never



JAPANESE BOARDING HOUSE OF PACIFIC COAST LUMBER COMPANY, VANCOUVER, B. C.



HEAD OFFICE OF THE PACIFIC COAST LUMBER COMPANY, VANCOUVER, B. C.
Photo Taken During the Mining Engineers' Visit, August, 1905.

the company has also been worked out in flowers, the full length of the lawns.

A representative of the CANADA LUMBERMAN was shown through one of these boarding houses by Mr. J. G. Scott, the general manager of the Company. Everything is in splendid condition. The building, which is three stories high, is well laid out. The lower flat is occupied by the large dining room, kitchen and store rooms, also well equipped bath

succiently set forth in Bulletin 21 recently issued by the Bureau of Provincial Information, Victoria, of which Mr. R. M. Palmer is secretary. The pamphlet is very convenient in size, attractively prepared, and reflects great credit on all those instrumental in its production.

The acreage of timber under lease is about 2,000 square miles, and the total area of forest and woodland is estimated by the Statistician at 285,554 square miles, or 182,-

been reached, the annual cut running between 300,000,000 and 350,000,000 feet.

Exact figures as to the amount of capital invested in lumbering in British Columbia are hard to obtain, but a conservative estimate places the aggregate at \$4,250,000, represented by mills, logging plants, logging railways, tug boats, etc., and exclusive of the value of lands purchased and leased as timber limits, which would total at least \$1,500,000 more.

The bulletin also sets forth the possibilities of the pulp industry, and in this connection, after alluding to the various companies already formed, says:

"The markets that can, with special facility, be supplied from British Columbia, are: Japan, Australia, China, New Zealand, Hawaii, the Philippines, Western Coast of South America, Western Coast of Mexico, and Asiatic Russia. The home market is a rapidly-growing one, and with the steady growth of population a correspondingly rapid increase of the requirements in the way of paper may reasonably be anticipated. The long distance from the Eastern mills and the freight rates make competition from the East impossible.

The work of building Small & Bucklin Lumber Company's saw mill at New Westminster, B. C., will soon be completed.

"STERLING" OILS

FOR SAW MILLS

WE SOLICIT ORDERS
TRADE LARGE AND SATISFACTORY
OUR AGENTS WILL CALL WITH "STERLING" CYLINDER,
ENGINE, DYNAMO, MACHINE AND SPECIALTY OILS

Greases, Packing, Waste, "Copperine," Ready Mixed Paints, Varnish, Red and Black Roof Paint; Smoke Stack Black for Boiler Fronts and Sawmill Refuse Burners, White Lead, Dry Colors, Etc.

Canadian Oil Co., Limited
Strachan Avenue, TORONTO, ONT.

Please mention THE CANADA LUMBERMAN when corresponding with advertisers.

Galt Machine Knife Works



MACHINE KNIVES OF EVERY DESCRIPTION
FOR **Woodworking Machines**
... Send for Price List ...
The Peter Hay Knife Co., Limited - Galt, Ont.

CANADA LUMBERMAN

AND WOOD-WORKER

WEEKLY EDITION

The Lumberman Monthly Edition 44 pages} \$1.00/PER YEAR {The Lumberman Weekly Edition every week.

THIS PAPER REACHES REGULARLY THE PRINCIPAL LUMBER MANUFACTURERS AND DEALERS THROUGHOUT CANADA, AND WHOLESALE BUYERS IN GREAT BRITAIN, THE UNITED STATES, AND OTHER FOREIGN MARKETS.

VOL. XIII

TORONTO, MONTREAL — NOVEMBER 1, 1905 — WINNIPEG, VANCOUVER

No. 34

CANADA LUMBERMAN

PUBLISHED BY

The G. H. Mortimer Publishing Co.'s
of Toronto, Limited

Confederation Life Building - TORONTO.

Branch Offices:

38 ALLIANCE BUILDING, MONTREAL
720-721 UNION BANK BUILDING, WINNIPEG.
Telephone 1274.

536 HASTINGS ST., SUITE 3, VANCOUVER, B. C.
22 GREAT ST. HELEN'S, LONDON, E. C.

The Weekly Lumberman—Published every Wednesday, contains reliable and up-to-date reports of market conditions and tendencies in the principal manufacturing districts and leading domestic and foreign wholesale markets. A weekly medium of information and communication between Canadian timber and lumber manufacturers and exporters and the purchasers of timber products at home and abroad.

The Monthly Lumberman—A 44-page journal, discussing fully and impartially subjects pertinent to the lumber and wood-working industries.

WANTED AND FOR SALE

Advertisements will be inserted in this department at the rate of 15 cents per line each insertion. When four or more consecutive insertions are ordered a discount of 25 per cent. will be allowed. This notice shows the width of the line and is set in Nonpareil type; 12 lines make one inch. Advertisements must be received not later than 4 o'clock p. m. on Tuesday to insure insertion in the current week's issue

FOR SALE—ABOUT 40 M. FEET 1" GOOD Ash Culls. Apply Box 111, CANADA LUMBERMAN, Toronto.

CEDAR FOR SALE—10,000 PCS. ROUND Cedar 8-16 and 25 feet long, at the Spanish boom. Also cedar, pine and spruce lumber for sale here at Larchwood. JAMES MCCREARY, Larchwood, Ont.

HEM-LOCK DRY HEMLOCK WANTED—ALSO Cedar Shingles and Lath. TORONTO LUMBER COMPANY, 432 Logan Avenue, Toronto.

FOR SALE

A QUANTITY OF CEDAR AND HEMLOCK R. R. Ties, No. 1 and 2; 10,000 Cedar Fence Posts; 1" and 1 1/4" Basswood; 2" and 3" Maple; cut in 1904; excellent shipping condition. 1905 cut contains Pine, Hemlock, Basswood, Maple, Elm and Ash lumber and 10,000 cords Slabs. LILLICRAP, TATE LUMBER CO'Y., Lakefield, Ont.

FOR SALE

Large Tract of Timber

THE PROPERTY OF

The Canadian Land and Immigration Company of Haliburton, (Limited)

This company has a large tract of well timbered land about 125 miles north-east of Toronto. There are large quantities of Cedar, Hemlock, Spruce, Balsam, Basswood, Beech, Cherry, Birch, Maple, also considerable Pine, Elm and Ash on this tract. It is well served by two railroads, one of which is about to be extended through the centre of the property. The company are prepared to sell this timber in blocks ranging from 5,000 to 10,000 acres, or more if desired.

There are several good mill sites on the property. This would be a good opportunity for parties who are at present cut out and are looking for a new location.

Maps and plans and further particulars can be had by applying to

W. H. LOCKHART GORDON,
Managing Director,
157 Bay Street, Toronto.

WANTED—TEN THOUSAND CORDS Hard and Soft Wood; also same quantity of Slabs. SIMCOE WOOD AND LUMBER CO., 52 Yonge Street Arcade, Toronto.

FOR SALE—REDBIRCH, HEWED SQUARE, 12 inch and up, 12 feet to 16 feet long. Apply Box 325 CANADA LUMBERMAN, Toronto, Ont.

WANTED, HARDWOOD SALESMAN to cover Ontario and New York State, must be experienced and acquainted with trade, good salary to the right man. Address Box 324 CANADA LUMBERMAN, Toronto, Ont.

A LARGE MILL IN THE EASTERN TOWNSHIPS cutting annually 2 million ft. birch lumber for English Market would like to find some one who could work up waste stock into chairs, etc. Renting part of mill with power for the purpose. Address GREAT NORTHERN LUMBER CO., LTD., Scotstown, Que.

FOR SALE AT A BARGAIN—NO. 3 HAMILTON Carriage Steam Feed, 7 1/2" cylinders and all connections, circular outfit complete with iron husk, mandril, etc. Two boilers 22 feet long, 4 feet in diameter, six boilers 20 feet long and 4 feet in diameter, two 14" flues in each. Full Second Hand outfit for Circular Mill. THE ONTARIO LUMBER COMPANY, LIMITED, Toronto, Ont.

BIRCH WANTED

CORRECTED SIZES.

3 inches x 8 inches x 14 ft. plump

also

3 1/2 " x 8 " x 14 ft. "

Clear Stock, free from knots, hearts and shakes

5 to 20 Carloads

Name price, delivered Toronto, and quantity can supply

Also a few cars choice Hard Maple
3 1/2 inches x 6 inches x 7 ft. or 14 ft. long

MASSEY-HARRIS CO. Limited,
Toronto, Ont.

MACHINERY FOR SALE

We have for sale the following second hand machinery, in good condition. Write us for full particulars and prices of any machine.

- 1 26" x 32" engine, box frame, slide valve on top of cylinder, driven with rock shaft.
- 2 No. 3 single cutting band mills, made by Prescott Co.
- 2 Two block carriages with Prescott offset, made by Prescott Co.
- 1 Two block Garland carriage.
- 1 Boss shingle machine, made by Mowry.
- 1 Hall shingle machine.
- 4 Perkins Grand Triumph shingle machines.
- 3 Drake hand shingle machines.
- 4 Perfection power shingle machines.
- 1 Double block shingle machine, Perkins make.
- 1 Drag saw.
- 1 Knee bolter.
- 1 Perkins Class A cut-off.
- 2 Wheel jointers.
- 2 Knot saw frames.
- 7 Shingle packers.
- 1 Heading trimmer.
- 2 Rich automatic saw sharpeners.
- 1 Independent condenser.
- 1 Portable boiler and engine, boiler with 32" fire box, and 28-3" tubes, 12 h p., engine 8 x 12.
- 1 Greenlee No. 1 improved automatic cut-off machine, with countershaft.
- 1 Friction feed complete, frictions 15" wide.
- 1 36" standard Lefel water wheel.
- 1 Upright boiler 70" x 32" with sixty 2" tubes.
- 1 " " 54" x 32" with ninety 1 1/2" tubes.
- 1 10" x 16" twin engine, steam feed, complete.

THE WM. HAMILTON MFG. CO., LIMITED
Peterborough, Ont.

WANTED, ORDERS FOR HICKORY RIM strips and shaft strips, quartered white oak and rough yellow pine. MCCLURE LUMBER CO., Detroit, Mich.

FOR SALE—ABOUT 150 M. FEET 1" MIXED hardwood culls, on C.P.R. line. For particulars address WM. SMITH, 393 ST. ANTOINE ST., Montreal, Que.

FOR SALE, A GOOD SAW MILL, CAN SAW from 15 to 25 thousand per day, with everything complete, nearly new. Apply to ROBERT STEWART, Vasey P. O., Ont.

WANTED, NORWAY PINE, ALSO WHITE Pine—quantity No. 3 and No. 4, 1-inch, 1 1/4-inch and 1 1/2 inch. Quote us f.o.b. Chicago. AMERICAN BOX COMPANY, Chicago, U.S.A.

I WANT TO BUY A SECOND-HAND SAW MILL that will cut from 15 to 25 M per day of 10 hours. Must be good and sound, with Lath Machine, Trimmers, Double Edger, etc. Address A. MCBETH, Kippen, Ont.

WANTED—LARGE QUANTITY OF 1-INCH Maple, must grade common and better, state quantity, very best price and shipping point. Apply M. McBurnie, care CANADA LUMBERMAN, Toronto, Ont.

WANTED—A MAN WITH A GOOD PORT- ABLE mill to saw lumber in the county of Hastings during the winter and spring of 1906 and succeeding one or two seasons. Address Box 326 CANADA LUMBERMAN, Toronto, Ont.

HAVE YOU ANY STOCK WHICH YOU wish to sell? If so, make the fact known to probable buyers by placing an advertisement in the Wanted and For Sale Department of this journal. Address, CANADA LUMBERMAN, Toronto.

WANTED.

LATHS BY CAR OR VESSEL, ANY QUAN- TITY, large or small, up to 10,000,000, 1 1/2" or 1 3/4". Address C. S. WENTWORTH & Co., 147 Milk Street, Boston, Mass.

SAWMILL PROPERTY FOR SALE, INTER- IOR of British Columbia; favorably situated on railway, with good water facilities. 1,440 acres good timber; very convenient; capacity of mill 20,000 per day. Apply J.M., care CANADA LUMBERMAN, Vancouver, B. C.

WANTED—BIRCH, ASH, BASSWOOD, ELM, Oak logs, strictly 1st quality, carload lots, 20 inches and up. A small % of 15 to 20 inches taken, steady trade. Quote delivered price F.O.B. Buffalo or at point of shipment. Can use almost any length. For further particulars apply THE DAVID GILMOUR DOOR CO., Buffalo, N. Y.

WANTED.

IN NEW ONTARIO, A BUYER OR A PART- NER with capital, to take half interest in water power Saw mill and lumber business. A large amount of timber adjacent to mills; this is a snap; will sell outright or half interest. Address HARRIS & Co., Day Mills, Ont.

TIMBER LIMITS FOR SALE ON THE RESTIGOUCHE RIVER, N.B.

A large tract of wilderness land well timbered with spruce, cedar and hardwood, principally spruce of virgin growth, situated on the Restigouche about 20 miles above Tide Head; easy of access and can be operated with little expense. A rare chance for those wanting to embark in the manufacture of lumber. For further particulars apply to O. SMITH, Campbellton, Restigouche Co., N.B.

The saw mill of the Upper Yukon Consolidated Company at Caribou was destroyed by fire on October 14th. The mill had a daily capacity of about 30,000 feet and the loss is estimated at \$50,000.

CURRENT TRADE CONDITIONS. ONTARIO.

Manufacturers are have every confidence in the white pine market, which they believe shows strong evidence of continued firmness. The desire of American dealers to acquire stock even at the present high price is doubtless due to the falling off in the supply from the Lake Superior district, where there is very little lumber that has not passed out of first hands. Buffalo and Tonawanda wholesalers have been ready buyers of all the lower grades, which have been leading in point of demand all season. There is a constant enquiry for mill culls, which bring from \$11 to \$14 at the mill, according to location. Dead culls are worth from \$7 to \$9.

There is not much animation to the hardwood trade and prices are somewhat irregular. Mill run basswood, for instance, is held by some manufacturers at \$20, while others are offering it at \$18 and claim that even at this figure buyers are not plentiful. The salvation of the hardwood trade would seem to depend to some extent upon the extent of logging operations this winter. If the output is not greatly curtailed so as to permit of the existing stock of lumber being worked off, it may be difficult to maintain prices at the present low basis, and this notwithstanding the fact that the cost of manufacture warrants an advance.

QUEBEC AND NEW BRUNSWICK.

Some of the St. John mills have resumed operations, a raft of 1,000,000 feet of logs having arrived from the booms and about 2,000,000 feet more being expected. There is no hope, however, of getting out the many millions that are hung up on the Upper St. John river, and accordingly there will be a great scarcity of lumber next spring. There has been much activity in shipping to the United States, the figures for the three

months ended September 30th being \$573,175.17, as compared with \$336,178.64 for the corresponding time in 1904. These periods represent the shipments of lumber, clapboards, shingles, lath, pulp wood, etc. There were received at Boston in one week recently 24 schooners from the provinces loaded with lumber, shingles and lath. The demand continues active and the available supply seems to be steadily decreasing. The shingle market, on the other hand, lacks snap, which is the only reason why prices are not higher, as the supply is light. Extras are still offered at from \$3.30 to \$3.40 for Boston delivery.

MANITOBA AND BRITISH COLUMBIA.

The developments of the past two weeks have been in the direction of establishing higher prices for the lumber output of British Columbia. The coast mills, it will be remembered, cut the price of rough lumber for delivery to the Northwest to \$17 because the Mountain mills had reduced prices with the object of capturing the Northwest trade. There was an actual loss in selling lumber at this price. The manufacturers of the province, therefore, held a meeting in Vancouver recently and agreed to sell at one price, namely, \$19 per thousand. This agreement is looked upon with favor by the manufacturers and is likely to be followed by a further advance in the near future, as the business is not yet profitable. Orders are more plentiful and as the demand from the Northwest agricultural districts is likely to show expansion, prospects are brighter than they have been for the past year. Dealers who purchased rough lumber at the minimum price of \$17 will now be able to realize a good profit.

UNITED STATES.

The stability of the lumber market of the United States has not been impaired. As the fall advances the demand seems to grow more

urgent, with the result that many dealers have more orders on their books than they can fill. The northern pine situation is exceptionally strong. The extensive purchases of a Chicago dealer have been no small factor in sustaining prices, as it is said that about one-half of the total Lake Superior production has thus been absorbed. Such a condition does not inspire much hope of lower prices during the winter months. A strong demand continues at Buffalo, Tonawanda and New York, which points practically reflect the conditions existing throughout the whole Eastern States. Box and No. 1 and No. 2 barn are in short supply. Hemlock sells very readily and in some districts the demand is greater than the supply. A slight change for the better has occurred in the hardwood trade. Orders are more plentiful and prices a little firmer. There is a splendid call for plain oak, ash and birch, while elm, basswood and maple do not show as much life.

White pine and norway lath are eagerly inquired for. Chicago wholesale dealers are shipping white pine lath in mixed cars at \$5.25: No. 2 white pine at \$4.50, No. 1 norway at \$4.75, No. 1 hemlock at \$4.50, and No. 2 norway at \$4.25.

GREAT BRITAIN.

The improved conditions recently noted are becoming more marked. Inquiries for lumber are increasing notwithstanding the advance in prices which has taken place during the past few weeks. Transactions in spruce are quite numerous. The prevailing prices for spruce in the docks are £10 per standard for 3x9 inch second quality, £9 5s. for thirds, and £8 10s. for fourths. Importers are also willing to pay higher prices for stock to be delivered. Two cargoes from St. John, with about 60 per cent. seven and eight inch, changed hands recently at about £7 17s. 6d. per standard, and it is stated that for a small

cargo from one of the Baie Chaleur ports, with 60 per cent narrow stock, £8 2s. 6d. c. i. f. has been declined. The position of Quebec spruce in London and Liverpool is reported to be very strong. In second quality, 3x9 inch, there has been a rise of 5s. to 10s. during the past few weeks. The white pine market is firm but does not show the activity which characterizes the spruce trade. Birch lumber is said to be slated for an advance in the near future, the supply being light. Wane pine timber, on the other hand, is sluggish, the high price having greatly restricted consumption and induced the use of substitutes as far as possible.

STOCKS AND PRICES.

John Brooks has moved his portable saw mill from Kent county to Brooklyn, N. B., to saw for Charles Pickard. He expects to cut 1,500,000 feet.

A considerable quantity of timber will be required for a new wharf to be constructed at St. John, N. B., for which D. C. Clark has secured the contract. The timber to be used will consist chiefly of hemlock, red pine and southern pine.

The Big Bend Lumber Company, of Arrowhead, B. C., have started a large logging camp at Fourteen Mile, below Revelstoke, and another extensive camp is to be put in at Fosthall Creek. The company figure on putting in three more camps the coming winter, making five in all.

When blown-down white pine timber will bring \$7.50 per thousand, and norway \$6.50, the value of pine stumpage in the north can be appreciated. It also, in a way, explains why No. 6 boards are selling for about \$6.50 on the docks at Duluth.

Two large rafts of pulp wood, which were being towed from Musquash to Mispic, N. B., went to pieces between Cape Spencer and Black Point and drifted out to the open sea. The rafts belonged to the Inglewood Pulp Company and contained about 1,000,000 feet, practically all of which will be lost to the company.

ST. JOHN LUMBER SHIPMENTS.

According to figures obtained at the office of the United States Consul, the lumber shipments from the port of St. John, N. B., to the United States during the three months ended September 30th were much greater in value than those for the like period in 1904. The figures in detail are given below:

FROM NEW BRUNSWICK LOGS.		
	1904.	1905.
Long Lumber..	\$ 36,293.74	\$124,877.54
Lath	70,807.37	96,688.86
Clapboards....	2,387.63	257.50
Firewood.....		1,465.00
Piling	2,127.50	6,921.60
Pulpwood.....	1,590.00	1,538.00
Shingles	10,631.47	35,006.93
Staves and shooks	737.47	3,613.50
Wood Pulp	43,488.05	66,810.11
Totals.....	\$168,063.23	\$337,197.04
FROM MAINE LOGS.		
	1904.	1905.
Long Lumber..	\$143,477.50	\$198,667.38
Lath	16,887.25	22,555.25
Shingles	6,929.00	12,374.00
Clapboards....		2,381.50
Shooks.....	821.66	
Totals....	\$168,115.41	\$235,678.13
Grand Totals..	\$336,178.64	\$573,175.17
Increase, 1905 quarter		\$236,996.53

TIMBER LIMIT TRANSACTIONS.

The sale of the 800 acre lot of timber land at Memel, N. B., belonging to James C. Wright, which was made by public auction last August to Warren Downey for \$16,050, has been declared off and the property was sold last week to W. Malcolm Mackay, of St. John, at private terms. Peter J. McClelan, of Riverside, will have control of the property and will conduct the lumbering operations, which will be commenced at once. Mr. McClelan owns an adjoining property at Memel of about 690 acres, and the two properties make one of the most valuable timber areas in the province.

W. C. CRAWFORD

Tilbury Ont.
 Manufacturer of
Handles—Axe, Fork, Pick, Etc.
 Also Hard and Soft Wood Heading and Red, and White Oak, Maple and Elm Lumber
 Can supply Second Growth White or Red Oak squares up to 38 in. long in large quantities.

Planing and Matching
 —IN TRANSIT—

S. POMEROY, Grillia
 PLANING, MATCHING, RESAWING,
 SIDING, FLOORING, MOULDINGS
 in Car Lots.
 Factory near Station. Write for Prices.
 'Phone 113

KNIGHT BROTHERS CO. LIMITED **Burk's Falls, Ont.** **KILN-DRIED BIRCH FLOORING** **Send for Catalogue** ***** Samples by Mail** **KNIGHT BROTHERS CO LIMITED** **Burk's Falls.**

Keenan Bros., Limited
 Owen Sound, Ont.
HARDWOOD, HEMLOCK AND PINE LUMBER

We carry a full supply of native Hardwoods always on hand and solicit your inquiries. At the present time we have piled at outside points about 2,000,000 feet of Hardwoods, and about the same quantity of Hardwood, Hemlock and Pine piled here in Owen Sound, and we should be able to interest you if in the market.
WILL MAKE SPECIAL PRICES ON BROKEN LOTS AT OUTSIDE POINTS

MASON, GORDON & CO.
 80 St. Francis Xavier Street - MONTREAL, QUE.
 WHOLESALE **LUMBER and TIMBER**
 Car and Cargo Lots Only
 Specialty: Dimension Timber in DOUGLAS FIR, PINE, HEMLOCK, SPRUCE, YELLOW PINE or OAK.
 Correspondence Solicited.

EVERYTHING IN LUMBER AND TIMBER
 DRESSED AND IN THE ROUGH
THE McLENNAN LUMBER CO., LIMITED
 MONTREAL QUE.
 Office and Yard, 571 DORCHESTER ST. P.O. Box 116

BRITISH COLUMBIA LETTER.

(Correspondence of the CANADA LUMBERMAN.)

VANCOUVER, B.C., October 23rd, 1905.—Conditions in the lumber industry in British Columbia are very good at present, and especially does this pertain to the coast mills. Local demand is brisk, Northwest trade is better than for many months, and the export business continues on a fairly large scale. In the last letter reference was made to the large number of ships which were loading at the Hastings mill, and figures which have since been made public show that this year will be one of the best in export the Hastings mill has had for some time. Approximately 40,000,000 feet will be sent to various parts of the world. At the Chemainus mills, also, ships are constantly taking on cargo for foreign ports.

Local mills are working full time with orders. This is the time of year when trade with the middle west is good, and added to this is the great local consumption of lumber. Building has been going on apace in Vancouver this year, which will be one of the best on record. Heaps & Company, The Royal City Mills, the Pacific Coast Lumber Company, the Rat Portage Lumber Company and the Vancouver Lumber Company are all very busy with local orders.

Prices are firm, without change. An advance is looked for in logs, but this may be stood off for a

while owing to the couple of weeks of very fine weather which has followed the wet September. Many logs will have been put in the water to supply the demand which shows as yet no signs of decreasing. Loggers are very confident that a sharp jump will be made before long in the price.

The continued poor condition of the shingle business is the only bad feature in connection with the industry. While prices do not alter to any extent, the demand is comparatively slack, without much prospect of immediate improvement.

Much activity is displayed on Vancouver Island. Americans are to the fore in securing large tracts of timber for sawmill purposes, and when they erect mills they will cut for the export trade. Work is progressing on the plant of the Seattle Cedar Lumber Manufacturing Company near Clayoquot. This will be a shingle mill having the capacity of 380,000 shingles every ten hours.

The E. H. Heaps Company had a bad fire last Tuesday when their dry kilns were burned with something over \$10,000 loss, partly covered by insurance. The men at the mill, with the brigade, worked several hours in saving the rest of the mill. Just at the time that the alarm was given, Mr. E. H. Heaps was proposing the health of his son's bride, the wedding having taken place that afternoon.

The Elk Lumber and Manufacturing Company, whose mill at Fernie

was burned down recently, announced that the rebuilding would take place at Hosmer, some miles from its former site. The C.P.R. offered inducements to this end, but the company has since decided to erect its new mill at Fernie. The structure will be of steel, and as nearly fire-proof as it is possible to make a saw mill.

NEW FREIGHT TARIFF.

The new C. P. R. lumber tariff on eastbound shipments from British Columbia, the conditions and terms of which were arranged in Vancouver several weeks ago, at a conference between representatives of the mills and C. P. R. freight traffic officials, took effect on November 1. The principal concession made by the railway to the lumbermen is the granting of the fir rate of forty cents per hundred pounds into Manitoba to rough cedar shipments which at present take a fifty-cent rate. The fir rate of fifty cents to Fort William is also to be dropped to forty-five cents. Mixing of fir and rough cedar and shingles in cars is also permitted at respective carload lot rates.

SPRUCE IN ENGLAND.

One week seems to bear a very close resemblance to another with regard to spruce, says the Timber Trades Journal of September 21st. The season can now be said to be practically at an end, as the steam-

ers to clear with the large deck loads have all sailed from their loading ports (the Canadian law prohibiting their departure after the 12th inst.), and as far as we can learn, are practically all disposed of, the latest sale being a 1,700 standards St. John cargo, containing 70 per cent. 7 in. and 8 in., with about 5 per cent. 3 x 11, at a fraction under £7 17s. c.i.f. to a Bristol Channel port. We should say that this compares

L. Dean Holden, Pres. J. M. Diver, Gen'l.-Mgr. F. A. Holden, Vice-Pres. E. C. Barre, Ass't Mgr

The Cleveland-Sarnia Saw Mills Co., Limited.

Manufacturers and Wholesale Dealers in

Timber, Lumber, Lath and White Pine Shingles

Special Bills Cut to Order in White Pine, Norway and Fir, any length from 10' to 60' long.

SARNIA, ONT.

TELEGRAPH POLES WANTED

We buy all lengths. Write us for prices and you will see that by cutting your Cedar into Poles it will net you more than you can get out of it in any other way.

J. B. FARWELL & SON

Successors to M'Caffrey & Farwell. Baneroft, Ont. Oswego, N.Y.

ARTHUR A. WATT

WIARTON, ONT.

Dealer in Hard and Soft Wood, Lumber, Lath, Shingles, Cedar Posts and Ties

SPECIAL.—50,000 4/4, 3/4 and 12/4 Soft Elm 30,000 3/4 Maple, C & B; 18,000 4/4 Soft Maple 100,000 4/4 M. R. Basswood; 18,000 4/4 Mill Run Pine Sidings, 40,000 4/4 and 3/4 Birch; 40,000 6/4 Beech. Prices on application.

THE KING AND BARTLES LUMBER CO.

PINE, POPLAR AND HARDWOODS

HEADQUARTERS HARDWOOD
Citizens' Building, Cleveland, O. Distributing Yard
McMinnville, Tenn.
We buy and sell Pine in Car and Cargo Lots

THE IMPERIAL LUMBER CO., LIMITED
SAW AND PLANING MILLS, WARREN, ONT.
RED AND WHITE PINE DEALS
All kinds of **SAWN LUMBER** By Carload or Cargo.
Registered Cable Address, "Pinewood." "American Lumberman" Telecode.
BRANCH OFFICE, MANCHESTER, ENG.
Head Office, TORONTO, CAN.

SAGINAW LUMBER & SALT CO.
MANUFACTURERS OF
LUMBER AND SALT
Mills at Sandwich, Ont.
R. H. ROYS, Pres.
RALPH LOVELAND, Vice-Pres.
C. A. KENT, Sec'y.
R. S. ABBOTT, Treas.
SAGINAW, MICH.

BANK ST. CHAMBERS OTTAWA, ONTARIO

W. B. BARTRAM

WHOLESALE LUMBER AND TIMBER MERCHANT

White Pine, Quebec Spruce and Hardwood.
Specialties: Basswood and Birch. Barge or car load lots
All Inquiries Given Prompt Attention.

J. GORDON MACLAREN

HINTONBURG, ONT.

DIMENSION TIMBER { In Spruce, White and Red Pine, up to 40 feet.
In Douglas Fir, up to 90 feet.

Every inquiry receives our Prompt attention.
Write for quotations. B. C. Cedar Shingles
SASH - DOORS - BLINDS

J. D. SHIER LUMBER CO., LIMITED
BRACEBRIDGE, ONT.
MANUFACTURERS OF
LUMBER, LATH AND SHINGLES
Pine, Hardwood and Hemlock Floorings and Ceilings. Sash and Doors, Wood Turnings etc. All Dressed Lumber Kiln Dried if desired. End Matched Flooring a Specialty.
GOOD PINE SIDINGS A SPECIALTY
Planing, Matching, Resawing, etc. In Car Lots.
Manufacturer of Doors, Sash, Mouldings, Ceilings
End-Matched and Bored **HARDWOOD FLOORING** ASPECIALTY.
Lumber Kiln Dried in Any Quantity.
J. R. EATON - Orillia, Ont.
Correspondence Solicited. Phone No. 54.

SEVERAL CARS THE LONG LUMBER COMPANY HAMILTON
CEDAR Long Distance Phones 1650-1651
SQUARES

CACHE BAY LUMBER INDUSTRIES.

Geo. Gordon & Co.,
Manufacturers of RED and WHITE PINE
Band - Gang LUMBER
Circular AND LATH
CACHE BAY, Ont. C. P. R. 26 miles West North Bay

CARTER POWELL LAND & LUMBER CO., LIMITED
604 Temple Building, Toronto
To **MILLMEN**—Cash buyers all kinds **HARDWOODS**
Cable address "Quartered Toronto." Codes, A. B. C., 5th and Lumberman's

Please mention this paper when corresponding with advertisers.

favorably with the sale reported in our last issue of a steamer cargo to the same district, this latter cargo containing 50 per cent. 3 x 9 and 10 per cent. 3 x 11, at £8 c.i.f. The iron and steel industries in the Midlands report active trade. This should have a tendency to give a healthy tone to the consumption of spruce at the Bristol Channel ports, and there is sufficient enquiry about to encourage the hope that still better reports will be forthcoming. In the North-West districts we have heard of no new sales to report, but judging from the visible activity in this neighborhood, we should say that spruce maintains the enhanced prices merchants paid.

is to come, millmen claim that this has necessitated a \$1 per thousand raise on all kinds of lumber.

In addition to the local members of the British Columbia Lumber and Shingle Manufacturers' Association who were present at the meeting, those from the interior were: Mr. F. W. Jones, manager of the Columbia River Lumber Company, Golden; Mr. Peter Lund, manager of the Crow's Nest Pass Lumber Company, Wardner; Mr. George P. Wells, of Palliser; and Mr. E. A. Watts, of Cranbrook.

In addition to the matter of prices, subjects of general interest to the industry were also discussed.

ADVANCE IN LUMBER PRICES.

Representatives of the lumber industry from all over the province of British Columbia held a meeting at Vancouver on October 23rd, when it was agreed to maintain a regular schedule of prices. For some time past there has been war between the manufacturers of the interior and the coast, as a result of which the coast men reduced the price of rough lumber from \$19 and \$20 to \$17. This practically put a number of the interior mills out of business. Now a satisfactory and harmonious basis has been arrived at.

Rough lumber has been restored to \$19, and is selling at that price uniform throughout the province. Because of the stiff price of logs and the almost sure increase which

BUSINESS NOTES.

The assignment is announced of the Detroit Box Company, Detroit, Mich. The list of creditors reaches seventy-five and the total liabilities \$68,104.41. One or two Canadian firms are interested.

Mr. Justice Perdue has made an order appointing the National Trust Company receivers of the Manitoba Lumber Company, which carried on business at Winnipeg, Roland, Carman and elsewhere. The application was made at the instance of the Foss Lumber Company. It is claimed that the directors have sold out their stock, that the concern is insolvent and the assets of the company are now being sold without there being any board of directors in charge.

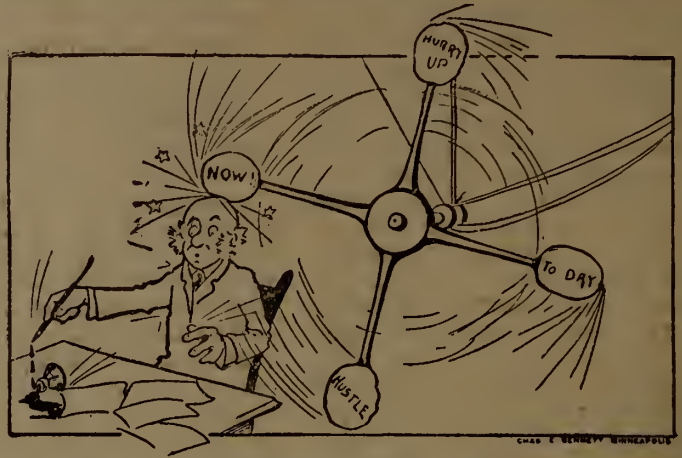

JUST A GENTLE REMINDER

That's all--a reminder that we can supply your wants in the lumber line. It's up to you NOW to realize that fact and to open up correspondence with us. Don't forget that SPRUCE LUMBER is our specialty—and should be yours. Let us tell you why.

The Red Deer Lumber Company
WINNIPEG, MAN.

UNITED STATES MANUFACTURERS AND WHOLESALERS

YOU
CAN
REACH

THE BONSAK LUMBER CO.
WHOLESALE HARDWOODS
ST. LOUIS
BY
RAIL, MAIL
WIRE OR
'PHONE

YELLOW PINE

We are in position to give first - class stock. Reasonable prices. Prompt shipments. Mills in Alabama, Mississippi and Arkansas.

MANN, WATSON & CO. Muskegon, Mich.

H. D. WIGGIN BOSTON, MASS.
89 STATE ST.

will inspect at mill and PAY CASH for

LOG RUN
Elm, Ash, Bass and other Hardwood
CORRESPONDENCE SOLICITED.

SAW AND PLANING MILL ANNUAL CAPACITY, 100,000,000 FEET.

THE DIXIE LUMBER CO.
WHOLESALE YELLOW PINE MANUFACTURERS
ST. LOUIS, MISSOURI.

Timbers, Rift Sawn Flooring and Finishing
Mills at LITTLE BAY, ARK., ALDEN BRIDGE, LA., ALLENTOWN, LA.

THE ROBERT H. JENKS LUMBER CO.
CLEVELAND, OHIO
MANUFACTURERS AND WHOLESALERS OF
YELLOW PINE, POPLAR, HEMLOCK AND HARDWOODS
Yellow Pine Timbers a Specialty

McGLURE LUMBER CO.
Wholesale Dealers in . . .
Hardwood Lumber
Carry in Stock and Have for Sale

ASH, BASSWOOD, BEECH, BIRCH, BUTTERNUT, CHERRY, CHESTNUT, COTTONWOOD, CYPRESS, ELM, GUM, HICKORY, MAHOGANY, MAPLE, OAK, POPLAR, SYCAMORE, WALNUT, POLES (Oak, Hickory and Ash), RIMS and SPOKES (Oak and Hickory), OAK BENDING PLANK, OAK BILL STUFF, RAILWAY TIES.
ROUGH YELLOW PINE TIMBERS and PLANK

Office and Yards: 520 to 530 Franklin St., DETROIT, MICH.
Mills: Eutaw, Ala.; McClure Station, Ala.

Correspondence Invited on All Hardwoods.

Indiana Lumber & Veneer Co.
INDIANAPOLIS, IND.

Sawed and Sliced Quartered
Oak a Specialty

Correspondence Solicited. <<<<

Veneers

FRANK G. BURY **BURY & NOBLE** MASON A. NOBLE

WHOLESALE **LUMBER - DETROIT** MICHIGAN

Send us your inquiries for Southern Yellow Pine.

CANADIAN MANUFACTURERS and WHOLESALERS

THE PEMBROKE LUMBER CO.
PEMBROKE, ONT.

We make a specialty of Dimension Stock in Pine, Spruce and Hemlock, and solicit your enquiries.

ALBERT J. DELAPLANTE
WHOLESALE

Pine, Hemlock, Lath, Shingles, Etc.

Office: 503 Manning Chambers - - TORONTO

FOR Pine, Hemlock, or Hardwood, Lumber and Timber, Telegraph Poles, Ties, Posts, Lath, Shingles, Dressed Lumber, Sash, Doors, Interior Finish, End Matched and Bored Hardwood Flooring, etc., try

JOHN HARRISON & SONS COMPANY, LIMITED

We have a complete stock, two Saw Mills running in summer and one all winter. HEAD OFFICE. SAW AND PLANING MILLS, OWEN SOUND, ONT.

RHODES, CURRY & CO., Limited
LUMBER MERCHANTS.

Yards at Amherst, Little Forks, Sydney and Halifax. BUILDING MATERIAL of all kinds carried in stock. We are buyers of Ontario Basswood, Elm and Pine. Amherst, N.S.

Sawn and Hewn Spruce, Hemlock; Pine and Birch Timber, Spruce and Pine Boards and Plank, Birch and Ash Boards and Plank, Flooring, Shingles, etc.

JAMES J. MURPHY, Bank of Hochelaga Building QUEBEC

F. MCGIBBON & SONS, PENETANGUISHENE ONT.

Manufacturers of Pine, Hemlock and Hardwood Lumber, and dealers in Cordwood Hemlock Bills cut on short notice.

The Cook & Bros. Lumber Co. MANUFACTURERS OF
Of Ontario, Limited
MILLS at SPRAGGE, Algoma Dist., Ont. on "Soo" Branch C. P. R.
OFFICES { Manning Arcade, Toronto
Corstine Building, Montreal
And at Mills at Spragge.
White and Red Pine Lumber and Lath
Water Shipments

THE M. BRENNEN & SONS MANUFACTURING CO., LIMITED

Saw Mills at RAINY LAKE, Ontario. Planing Mill and Head Office: HAMILTON, Ontario.

THE NIPISSING LUMBER COMPANY, LIMITED

Mills at CACHE BAY and SPANISH RIVER, Ontario. Manufacturers of and Wholesale Dealers in all kinds of **LUMBER AND LATH**
Both Railway Delivery and Water Shipments. Correspondence Solicited. The NIPISSING LUMBER CO., Limited Head Office: HAMILTON, ONT.

A. F. BURY AUSTIN
WHOLESALE LUMBER and TIMBER
CANADA PINE

Bank of Ottawa Building, 224 St. James St., - MONTREAL, CANADA
SPECIALTIES: Railway Bridge Timber and all kinds of Hardwoods; Ship Decking, Norway and White Pine, Dimension Timber, Norway Car Sills, Car Flooring, Telegraph Poles, Railway Ties, Oak and Whitewood, Planed and Rough Lumber, British Columbia Pine, Southern Pine, &c.; Birch Flooring, hollow back, end butted.

Eastern Agent for The Pacific Coast Lumber Company, Limited, Vancouver, B. C.
Douglas Fir Timber in any size or length up to 90 feet long. Timber Planers face up to 24 inch x 30 inch. Dry Kilns of large capacity. Rough and Dressed Lumber, Douglas Fir and Cedar.

AUGER & SON

We Buy, Sell and Deal in all kinds of Lumber and Timber in Canada and United States: Spruce, White Pine, White and Basswood, Ash, Cedar, Douglas Fir, Beech, Birch, Walnut, Cherry, Chestnut, Cottonwood, Hemlock, Maple, Norway Pine, Short and Long Leaf Yellow Pine, Oak, Redwood, Birch, Maple and Oak Floorings, Pulpwood, Ties and Cedar Poles

Quebec

R. LAIDLAW LUMBER CO.

JAS. PLAYFAIR. D. L. WHITE.
PLAYFAIR & WHITE
Manufacturers and Wholesale Dealers
LUMBER • LATH • SHINGLES

Contractors for Railway Supplies BILL TIMBER a Specialty MIDLAND, ONT.

A. & P. WHITE Manufacturers of and Dealers in
Sawn and Planed Lumber, Dimension Timber. Joisting Car Sills, Car Flooring, Shingles and Lath.
PEMBROKE ONT.

MAITLAND, RIXON & CO. OWEN SOUND, ONTARIO.
Manufacturers and Dealers

LUMBER LATH, TIES, POLES, SHINGLES, ETC.
Make a Specialty of Long Pine, Cedar and Hemlock Bill Stuff. We ship by C. P. R., G. T. R., and by Water.

Turner Lumber Co., Limited
MANUFACTURERS
LUMBER and LATH
Shipments by Rail or Water. • Midland, Ont.

HARDWOOD FLOORING
End Matched, Bored, Steel Polished, and Bundled
Send for Price List
A few cars of selected Maple and Birch and other Hardwoods at close price
THE SEAMAN KENT CO., Limited
160 Bay St. Toronto Factory, Meaford, Ont.

HARDWOOD FLOORING
MANUFACTURED IN
MAPLE, BIRCH, BEECH AND OAK
3/8, 1/2, 3/4, 1 1/4 and 1 3/8 inch thicknesses. Kiln-Dried, Hollow Backed, End Matched, Bored and Polished, bundled with wire baling. . . . Also Stock fully machined for Spring Red Frames and
ALL KINDS OF HARDWOOD LUMBER
J. S. FINDLAY - OWEN SOUND, ONT.

A SPLENDID ROUTE.

The Wisconsin Central Railway is justly termed the "Sportman's Line" because it reaches into and through the very heart of the choicest hunting grounds in America. The very best wild fowl shooting of the entire North is reached ONLY by this line. Hundreds of beautiful lakes abounding in wild rice and celery attracts myriads of ducks and geese and afford the finest kind of cover and the choicest shooting to be found the country over. The Wisconsin Central Railway caters especially to the sporting public and during the various seasons for hunting and fishing furnishes daily information to its patrons as to local conditions anywhere along its lines upon application to the nearest ticket agent. It also arranges its train service with special reference to the convenience and comfort of sportsmen, and its employes are constantly on the alert to make travel over their lines pleasant and comfortable. This line offers the best route between Chicago, St. Paul, Milwaukee, Minneapolis or to Lake Superior points via Ashland, Wisconsin. Information given by addressing—
JAS. C. POND, Wis. Cent. R. R. Milwaukee

ADVERTISE YOUR WANTS IN
Weekly Canada Lumberman
Toronto Montreal Winnipeg
Vancouver

Cedar Cove Mill,
Vancouver, B.C.

E. H. HEAPS & CO.,

Vancouver, B. C.

Ruskin Mill,
Ruskin, B. C.

Lumber, Lath, Shingles, Doors, Mouldings, Etc.

SPECIALTIES :

AA1 HIGH GRADE CEDAR SHINGLES.

Cedar Bevelled Siding, Cedar Door and Sash Stock, cut to size, Cedar Finish, Base, Casing, Newels
Balusters, etc. Douglas Fir Timber up to 85 feet in length.

W. J. SHEPPARD, PRESIDENT Waubushene, Ont.	J. G. SCOTT, GENERAL MANAGER Vancouver, B.C.
MANUFACTURERS OF	
FIR, CEDAR AND SPRUCE LUMBER LATH, MOULDINGS TURNED WORK ETC.	Pacific Coast Lumber Co., Limited VANGOUVER, B.C. HIGH GRADE RED CEDAR SHINGLES
Ontario Representative, W. J. LOVERING, 112 Mail Building, TORONTO	

D. C. CAMERON, President and Manager.

WM. ROBERTSON, Secretary.

J. E. YOUNG, Cashier.

The Rat Portage Lumber Co., Ltd.

Manufacturers
of

White and Red Pine Lumber, Lath, Shingles, Sash, Doors, Turned and Band Saw Work

Dealers in CEDAR POSTS, POLES and TAMARAC PILING

Mills at RAT PORTAGE and RAINY RIVER, Ontario WINNIPEG, Manitoba, and VANCOUVER, British Columbia. Head Office: RAT PORTAGE, Ontario
Our Vancouver Mill cuts High-Grade Cedar, Fir, Spruce and Red Cedar Shingles. Winnipeg Mills cut Pine, Tamarac and Spruce Lumber
We also Manufacture all kinds of Mouldings, Sash, Doors, Turned Work and Boxes. Correspondence solicited at all four points.

Export Lumber & Shingle Co., Limited Vancouver, B. C.

We are Exclusive Selling Agents in Canada
for 40 per cent. of the Shingles manufac-
tured in British Columbia. Daily shipping
capacity over 1 1/4 millions.

W. C. WELLS

PALLISER, B. C.
Manufacturer of
High Grade Spruce, Fir, Cedar
and Lumber of all Descriptions.
CORRESPONDENCE SOLICITED.

W. B. MCKECHNIE, President.

C. MACRAE, Manager.

THE ALBERTA LUMBER CO.

Vancouver, B. C. LIMITED

BRITISH COLUMBIA RED CEDAR

All sizes to 24 inches wide, by 24 feet long—CLEAR.
B. C. FIR—DIMENSION AND FINISH.

SCRIBNER'S LUMBER AND LOG BOOK

A handy book for Lumbermen. Gives Correct Measurements
of Scantlings, Boards and Planks; Cubical Contents of Square
and Round Timber; Doyle's Rules, and much other practi-
cal information.

Price 35 Cents

ADDRESS THE CANADA LUMBERMAN, TORONTO, ONT.

1,500,000 Shingles Per Day

About half the B. C. Shingles used in Canada are sold by us. Our Daily Shipping Capacity is over One Million Shingles.

LUMBER

DOUGLAS FIR, SPRUCE and CEDAR
Fir and cedar Lath

DOORS, WINDOWS, MOULDINGS, NEWELS, BRACKETS, BALUSTERS and all descriptions of INSIDE and OUTSIDE FINISH

We make a Specialty of the handling of Timber Lands, Mill Properties and Lumber

Investments generally

—Correspondence Invited—

P.O. Box 407 **UNION LUMBER COMPANY, Limited** Head Office: 536 Hastings St. **Vancouver, B. C.**

WE have Three Millions of Hemlock, running in lengths from 10 to 24 feet, which we are prepared to cut in blocks of 50,000 feet or over.

THE WOODSTOCK LUMBER & MANUFACTURING CO.

Dealers in Pine, Hemlock and Hardwood Lumber..

WOODSTOCK, ONTARIO

PEDWELL & LEMCKE, Lions Head, Ontario

MANUFACTURERS OF Pine, Hemlock and Hardwood Lumber, Shingles, Ties, Poles, Posts, Etc.

Rail or Water Shipments.

Correspondence Solicited.

BRITISH WOOD BROKERS AND IMPORTERS

FARNWORTH & JARDINE

Wood Brokers and Measurers

Cable Address "Farnworth," Liverpool. 2 Dale St., 71 Regent Road **BOOTLE, LIVERPOOL, ENG**

F. A. Lightbody & Co.

8 Gordon Street - GLASGOW, SCOTLAND

WOOD BROKERS

Cable Address: "TENEBRIS," GLASGOW. Codes: A. B. C., A 1, "Zebra" and Private.

Agents for **CANADIAN WHITE PINE AND SPRUCE**; Hardwoods in Log, Etc. Shipments handled to the best advantage to all ports in the United Kingdom. Correspondence Solicited.

LOUIS BAMBERGER, 2 Broad Street Building, LONDON, E. C.

IMPORTER OF Telegraphic Address "Bellywood, London."

Pine, Spruce and all Canadian Wood Goods

Are Open to Contract for Glued-Up **BASSWOOD KEYBOARDS**

ZEBRA CODE

A. B. C. CODE

DIRECTORY CODE

GELLIBRAND, HEYWOOD & CO.

Wood Agents and Brokers

Cable Address: "GELLICHT," LONDON 57 Gracechurch St. London, E.C. England

FELBER, JUCKER & CO.

Lumber Importers

MANCHESTER ENGLAND

Invite offers from Lumbermen for . . . Spruce Deals and Battens, Spruce and Pine Floorings, Shooks, Sashes, Mouldings, Dowels, Broom Handles, Chair Stock, Seats, etc., or any Woods suitable for English Market.

Telegraphic Address: FELBER MANCHESTER.

ONE DOLLAR

Will pay your subscription to the CANADA LUMBERMAN for

ONE YEAR

SMITH & TYRER - 14 Tithebarn Street, LIVERPOOL

.. **WOOD AGENTS** ..

Cable Address—"Walmer," Liverpool.

Halifax, N.S., Office—SMITH, TYRER & Co., Metropole Bldg., Hollis St. Halifax, N.S.

Edmiston & Mitchells

TIMBER BROKERS

Cable Address: "EDMISTON" Glasgow.

33 Renfield Street, GLASGOW

GANT & KEMP  **TIMBER BROKERS**

52 St. Enoch Square, GLASGOW

Cable Address: "TECTONA" Glasgow. A1 and A B C Codes used.

Telegrams and Cables: "Woodfeller, London."

Codes: Zebra, Western Union, Southards, and A. B. C. 4th and 5th Editions.

THOMPSON, BLOIS & CO.

Buyers of all Kinds of Lumber and Logs

17 GRACECHURCH STREET: LONDON, E. C.

Cash advances made against shipping documents.

Branches: MANCHESTER, HAMBURG.

JOSEPH OWEN & SONS, LTD.

Timber Importers

Cable Address "Owen Liverpool" Liverpool, Eng.

BUYERS OF

White Ash Logs and Planks. Oak Logs and Planks. Rock Maple Logs and Planks. Rock Elm Logs. Hickory Logs.

... ALSO ...

All classes of Lumber and Manufactured Wood Goods suitable for the English Market.

JAMES WEBSTER & BROTHER

BOOTLE, LIVERPOOL, ENGLAND

TIMBER MERCHANTS

BUYERS OF Oak, Birch, Ash, Grey Elm Logs and Lumber, Elm Staves and Heading, Handics of all descriptions Veneers A Specialty

ALFRED DOBELL & COMPANY
WOOD AGENTS AND BROKERS

Liverpool and London Chambers - LIVERPOOL, ENGLAND

CABLE ADDRESS "DOBLE LIVERPOOL"

THE ONTARIO LUMBER CO. LIMITED

MILLS: North Bay, C.P.R. and G.T.R. Delivery.

WHITE PINE LUMBER, LATH AND SHINGLES.

35 and 36 Home Life Building TORONTO, Ont. MILLS: French River, Georgian Bay Water Shipment Only.

EMPLOYMENT BUREAU R. B. ST. GEORGE RAILWAY, LUMBER and CONTRACTORS' AGENT

158 Canal St, Russell Block, Ottawa. Men wanted at all times for Bush and Railroad Work. Phone 1,950

McLennan Timber Land and Lumber Co., Limited

Selling Agency and Dealers in all kinds of Timber Lands. Offices: Quebec, 131 St. Peter St. Ottawa, Room 9, Central Chambers.

CANADIAN LUMBER WANTED

We solicit consignments of long and short lumber from the Maritime Provinces and are prepared to purchase White Pine and Hardwoods in Ontario and Quebec.

ADDRESS: CHAS. S. WENTWORTH & CO. Room 510, 147 Milk St. - BOSTON, MASS.

GEO. G. GLADMAN MANUFACTURER OF WHITE PINE AND HEMLOCK LUMBER LATH AND SHINGLES PARRY SOUND, ONT. CORRESPONDENCE SOLICITED

A. P. EBERT MANUFACTURER OF AND DEALER IN

Pine and Hardwood Lumber, Lath, Shingles, Posts, Broom Handles, and Short Hardwood Dimension Stock WIARTON, ONT.

Is it your wish... To Purchase or Sell as quickly as possible A PARTICULAR LOT OF LUMBER A MILL PROPERTY SECOND-HAND MACHINERY

An Advertisement in the 'Wanted' and 'For Sale' Department of the CANADA LUMBERMAN WEEKLY EDITION Will secure for you a Buyer or Seller, as the case may be. Address, The Canada Lumberman, Toronto

Please Mention this Paper when Corresponding with Advertisers.

CURRENT LUMBER PRICES--WHOLESALE

TORONTO, ONT.

CAR OR CARGO LOTS.

Table listing lumber prices for various grades and sizes in Toronto, Ontario, including Pine cuts, Douglas fir, and Hemlock.

HARDWOODS--PER M. FEET CAR LOTS.

Table listing prices for various hardwoods such as Elm, Hickory, Maple, Oak, and Cherry.

QUEBEC, QUE.

WHITE PINE--IN THE RAFT

Table listing white pine prices in the raft for Quebec, Quebec.

RED PINE--IN THE RAFT.

Table listing red pine prices in the raft for Quebec, Quebec.

OAK--MICHIGAN AND OHIO.

Table listing oak prices from Michigan and Ohio for Quebec, Quebec.

ELM.

Table listing elm prices for Quebec, Quebec.

ASH.

Table listing ash prices for Quebec, Quebec.

BIRCH.

Table listing birch prices for Quebec, Quebec.

OTTAWA, ONT.

MANUFACTURERS' PRICES.

Table listing manufacturers' prices for various lumber grades in Ottawa, Ontario.

Table listing lumber prices for Pine good strips and shorts in Sarnia, Ontario.

SARNIA, ONT.

Table listing prices for Uppers and Selects in Sarnia, Ontario.

Table listing prices for Fine, Common, and Better grades in Sarnia, Ontario.

Table listing prices for No. 1 Cuts in Sarnia, Ontario.

Table listing prices for No. 2 Cuts in Sarnia, Ontario.

Table listing prices for No. 3 Cuts in Sarnia, Ontario.

Table listing prices for Mill Run in Sarnia, Ontario.

Table listing prices for Lath in Sarnia, Ontario.

Table listing prices for Shingles in Sarnia, Ontario.

ALBANY, N.Y.

Table listing prices for various lumber grades in Albany, New York.

Table listing prices for Pine, Spruce, and Hemlock in Buffalo and Tonawanda, New York.

Table listing prices for Lath and Shingles in Buffalo and Tonawanda, New York.

BUFFALO AND TONAWANDA, N.Y.

WHITE PINE.

(Wholesale selling price.)

Table listing prices for various white pine products in Buffalo and Tonawanda, New York.

The following quotations on hardwoods represent the jobber's buying price at Buffalo and Tonawanda:

Table listing prices for White Ash in Buffalo and Tonawanda, New York.

Table listing prices for Black and Brown Ash in Buffalo and Tonawanda, New York.

Table listing prices for Birch in Buffalo and Tonawanda, New York.

Table listing prices for Elm in Buffalo and Tonawanda, New York.

Table listing prices for Maple in Buffalo and Tonawanda, New York.

BOSTON, MASS.

Table listing prices for various lumber grades in Boston, Massachusetts.

NEW BRUNSWICK CEDAR SHINGLES.

Table listing prices for New Brunswick Cedar Shingles.

BRITISH COLUMBIA SHINGLES.

Table listing prices for British Columbia Shingles.

THE DOMINION EXHIBITION NEW WESTMINSTER.

The recent Dominion Exhibition at New Westminster, B.C., was singularly successful. Notwithstanding the prevalence of rainy weather for the greater part of the time, the attendance was large and much interest was shown in the numerous exhibits. Mr. George A. Gall, the British Columbia representative of this journal, was permanently established on the grounds, his headquarters being shown in the accompanying engraving. Here he re-

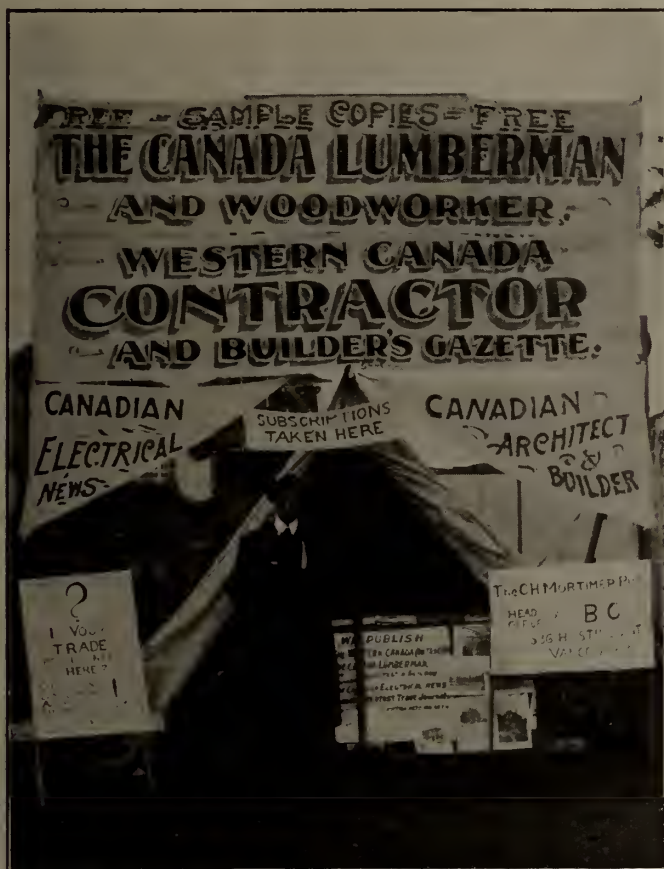

OUR HEADQUARTERS AT THE DOMINION EXHIBITION, NEW WESTMINSTER, B. C., SEPTEMBER 27 TO OCTOBER 7, 1905.

ceived hundreds of visitors from the West and some from the East. The publishers have unbounded faith in the future of Western Canada and intend in every possible way to promote the interests of western advertisers and subscribers. Our British Columbia office is located at Suite 3, 536 Hastings street, Vancouver, where friends of the paper will always be welcome.

NEW CANADIAN CAR SERVICE RULES.

Following are the new car service rules formulated by the Board of Canadian Railway Commissioners :

1. All freight in carloads, or less, handled by shippers or consignees, is subject to a service charge of \$1 per car per day of 24 hours, or part thereof, if not loaded or unloaded within 48 hours.

Exception.—Twenty-four hours additional will be allowed on cars loaded with coal and coke in bulk, boards and deals.

2. Cars delayed under load beyond the free time, for any reason for which shippers or consignees are responsible, will be subject to the car service charge.

3. On cars placed before 12 o'clock noon, free time begins at noon; if placed after 12 o'clock noon, free time begins at 7 o'clock

a. m. following. Cars to be accessible at all times during the period allowed for loading and unloading. Time lost through interruption, for which the railway is responsible, to be added to the free time allowance.

4. No charge will be made for Sundays or legal holidays.

5. When, owing to wet or stormy weather, loading or unloading is temporarily impracticable, agents will extend the free time allowance so as to give altogether the full free time period of suitable weather.

Agents must immediately report particulars to the manager, and note in their daily reports "waived Rule 5" opposite each car affected, giving dates on which the car service charge has not been assessed.

6. When, owing to irregularities in transportation, cars have been "bunched" and are tended to the consignee in numbers beyond his ascertained reasonable ability to unload within the authorized free limit, he shall be allowed such additional time as may be necessary to unload the cars so in excess, by the exercise of due and usual diligence. The agent must at once report the particulars to the manager and obtain his ratification.

7. When both cars and tracks are owned by the same private party, no charge will be made.

8. Consignees must be promptly notified of the arrival of their freight, and will be held to have been notified when notice of arrival is given at their address or place of business, or if notice is mailed to the address given on the way-bill, consignee will be held to have been advised at 7 a.m. of the day following.

9. Twenty-four hours will be allowed to consignees, after notice of arrival, in which to pay charges, if any, and give orders for special placing or delivery. If not ordered within that time, car will be considered as for public team track delivery, and will be placed accordingly, and if not unloaded within the free time will be subject to the car service charge.

Twenty-four hours additional will be allowed for clearance of customs, where the destination is a port of entry.

Where the destination is not a port of entry, 48 hours will be allowed for clearance of customs at the outside port of entry.

10. The extra time after notice of arrival for paying charges and ordering will not apply on cars for which agents have previous or standing orders or arrangements for placing for regular delivery on designated tracks or private sidings.

11. The delivery of cars to private tracks shall be considered to have been made either when such cars have been placed on the tracks designated, or when they would have been placed but for some condition for which shipper or consignee is responsible.

12. If, after placing, cars are ordered to

another siding on the same road to complete loading or unloading by the same shipper, or the same consignee, and no switching or reconsigning charge is made, the free allowance will be computed from the original placing, less the time occupied in replacing the car.

13. If car is reshipped or reconsigned, the original consignee shall pay \$1 per car per day, or part thereof, for all time in excess of the period allowed by these rules, so that 48 hours free time may remain to the party taking delivery.

14. Should a switching road give notice that it is unable to receive cars for private sidings, owing to conditions for which shippers or consignees are responsible, then any railway having cars for such consignee must so advise them. Car service will accrue until the cars are accepted by the switching road, and will be collected by the railway which is holding them.

15. Cars held in transit for inspection, cleaning, bagging, completion or change of load, change of destination, etc., and detained over the time allowed for such purposes, will be subject to car service charges, which must be billed forward as directed by the accounting department. If such shipments are transferred to other cars, the car service charges will follow on the cars to which transfer is made. The forwarding agent, or in the case of change of destination, the agent by whom arranged, must make the following notation on the bill of lading, "Subject to car service charges at" The amount must also be inserted in the "back charges" column of the bill of lading, when practicable.

16. So-called industrial, logging or private roads handling cars for themselves or other parties, must be charged car service on all cars delivered to them from the time placed upon the interchange tracks until returned thereto, allowance being made for the time necessary to perform the switching service (not to exceed 24 hours), in addition to the free time herein authorized.

17. Cars must not be held short of the destination for the purpose of evading these rules. Loaded cars held back for cause must be reported to the manager.

18. When cars are delayed or refused by consignees because of alleged incorrectness in the railway rates or charges, car service must be collected if charges or weights are found to be correct.

19. Agents must in all cases collect car service charges as soon as accrued. Should payment be refused, agents will withhold delivery, either by sealing or locking car, or placing it where it will not be accessible.

20. When the contents of a car are apparently not worth the combined freight and car service charges, and consignee fails to take delivery, the agent must wire the manager for instructions.

21. All complaints, disputes and uncertainties which may arise under these rules must be referred at once to the manager. The manager may reduce or cancel the charges should he consider that the circumstances justify such action.

Claims should be filed with the manager direct, and must be accompanied by the receipted bills for the amounts paid.

ARGUMENTS FOR AN IMPORT DUTY ON LUMBER.

The following communication from Mr. Alexander MacLaren, of Ottawa, one of the largest owners of milling plants in Canada, sets forth succinctly many of the contentions of the lumbermen of Canada regarding an import duty on lumber and shingles.

The question of an import duty on lumber coming into Canada, that is now agitating the public mind, presents itself to my mind as follows: Being a lumberman who is extensively interested in British Columbia, Manitoba and the Northwest, and also in Quebec, I am obliged to make a distinction between the west and the east—the west as represented by British Columbia, the Northwest Territories, Manitoba and Western Ontario, the east as represented by Eastern Ontario, Quebec and the provinces east.

Let us deal first with the west. Is it in the interests of the west and Canada in general (for anything that affects the west for good or evil affects the whole of Canada) to put in force a \$2 import duty on lumber?

Those against the \$2 duty say it will affect the development of the country—that the settler will have to pay more for his lumber. Well, suppose the \$2 duty was in force, how much increase in prices would the settler have to pay for his lumber? Certainly not a greater increase over the present or past prices than what that \$2 duty would amount to. Home competition regulates this.

It is estimated that two carloads of lumber, say, 30 thousand feet, will put up a house and a barn sufficient for a settler for the first ten or twelve years. Well, suppose I come to the settler and say: "I will furnish you that lumber for \$22 per thousand feet, or a total of \$660." "But," he says, "I can buy it from the American lumberman at \$20 or a total of \$600. Why should I give you \$60 more?" I reply, "I cannot sell at less or I would lose money, but I will tell you what I will do. You buy from me at my price and I will agree to take 20 per cent. of it in payment in hay, oats, horses, beef, wheat or its equivalent in flour. I will not only do that this year with you, but I will continue to do so for the next ten years. Not only that, but during the winter months, when your sons or your farm laborers are out of work I will give them work; i. e., for this \$60 additional, you create a direct home market for your produce and a home labor market for your farm help during the winter months."

"On the contrary, if you purchase from the American lumbermen you kill my lumber business and force me to shut down. Your \$600 goes out of the country, never to return. The American lumberman will not buy your hay and oats, horses, cattle, flour, etc., as he buys it from his own settler in his own country. Your labor market for your farm help during the winter is lost to you, or is at such a distance from you and in another country, that should your help go there to look for labor during the winter there is a danger it may never return."

Let this be presented to the settler in this way and who will he deal with? I see only one answer to this—the Canadian lumberman

of course. Then why should the settler object, or the Government hesitate, to put on the \$2 duty.

It is estimated that the consumption of lumber in Manitoba and the Northwest is some 600,000,000 feet per annum. In 1903 there was imported some 60,000,000, or 10 per cent. of the consumption. At present we have not got the importation for 1904, but it is believed it will be fully 20 per cent.

This 10 per cent. to 20 per cent. is bought by the middleman at lower prices than the Canadian manufacturer can afford to sell at.

Does the settler get the benefit of this?

It is claimed that the lack of the \$2 duty permits the settler to get his lumber that much cheaper, but this is not so. The manufacturer of lumber does not deal direct with the consumer. There is a middleman. He buys from the manufacturer and sells to the consumer. Naturally the middleman buys where he can buy cheapest. At present he is getting from 10 per cent. to 20 per cent. of his lumber from the American lumberman at, say, \$2 per thousand less. Does he give the settler or consumer the benefit of this?

No! He knows that it is not the 10 per cent. or 20 per cent. of the American commodity that regulates the market price, but that it is the 80 per cent. and 90 per cent. of the Canadian commodity that does so. Consequently, the middleman just gets an additional profit out of the settler or consumer. He uses the American lumber as a lever to increase his own profit.

You will also note that there are large areas of timber through Manitoba, the Territories and British Columbia not yet taken up. Should the consumption of lumber or demand increase there are large supplies to draw from and plenty of people ready to go into the business to manufacture same, and therefore, by competition among themselves, keep prices at a proper level, and is it not better to manufacture the lumber in your own country than to run the risk of having it destroyed by fire?

The more that is manufactured in Canada West, the more it will swell through its ground rents and royalties the exchequer of the Dominion and Provincial governments, and bring about a reciprocity of benefits to our own citizens.

There are, from time to time, large bonuses given by the Government to establish trade relations with foreign countries, but we should look to our internal affairs. Charity begins at home, and most people prefer a home market, where it benefits each and all, to a foreign one. If the Canadian lumbermen could get into the United States lumber market on the same basis as they get into ours, the western manufacturers could then, to some extent, take care of themselves by retaliating on the American lumbermen.

In conversation with one Northwest member he referred two or three times to the high prices of lumber in 1903, saying they had advanced as much as \$7 per thousand on some of the higher grades of lumber. This was not local to the Northwest or to Manitoba. It was general all over the world. Lumber was sold commonly on the Pacific Coast for export

trade at an advance of \$6 to \$7 in 1903 over prices of 1901 and 1902, and in Ontario and Quebec and throughout the United States the advance ranged from \$6 per thousand and upwards to over \$15 per thousand, or, in other words, lumber advanced all over the world from 50 per cent. to 100 per cent., but then the ordinary laborer's wages advanced in like proportion and other commodities that enter into the manufacture of lumber advanced also in more or less degree. Therefore, the Northwest member, or the consumer in Manitoba or the Northwest, should not blame the manufacturers of British Columbia or the Northwest for the great advances in lumber in 1903. It was a case all over the world of the demand exceeding the supply, aggravated by the fact that the demand sprang up very suddenly and transportation companies were unable to handle the amount of lumber even that was available.

Then, again, settlers and merchants from Ontario, Quebec and the Eastern Provinces, who were accustomed to the values of lumber in those provinces previous to 1902, would naturally find lumber very high, but he was not aware that in his old province a change had taken place and lumber was from 50 per cent. to 100 per cent. dearer; besides this, he did not take into consideration that it costs in railway freight \$12.80 per thousand on rough lumber from points on the coast to points in Manitoba and the Northwest, thus leaving a very small margin for the manufacturer.

I would point out to the consumer of Manitoba and the Northwest that matters now are rapidly drifting to a period when they will see even higher prices than were seen or dreamt of in 1903. Canadian mills are running half time and a great many are closing down and others will shortly close down. This will stop the building of more mills.

The consumption of lumber is increasing in Manitoba and the Northwest. More American lumber is coming in each year. What will be the position of the consumer in the Northwest when trade revives again all over the world? The American lumber will cease to come into Manitoba and the Northwest except at enormous prices. The bulk of the Canadian mills being shut down and no supply of logs on hand, the Canadian consumer will be up against a great shortage of lumber and prices will go soaring again for a couple of years.

What an opportunity the American lumberman will then have and a few Canadian lumbermen who can survive the present depression. Would it not be better to put on an import duty and maintain a steadier market by keeping our home industries alive than bringing about such a condition of affairs. Would not the country with its home industries alive, even although barely existing, and with trade again getting good all over the world, be in a better position to grow, and grow rapidly, taking advantage of the early growth and best part of the trade, and not the tail end of it.

I operate a mill at Barnett, B. C., with a capacity of about 25,000,000 feet per year. During a dull period it I could run it, cutting and selling say 15,000,000 feet per annum,

and merely pay expenses of operating, I would operate rather than shut down. The 100 odd million feet of lumber that now comes in from the American side would keep in existence seven mills the size of ours. A mill the size of ours, if shut down, would throw out of work some 450 men. Consequently on this basis, an import duty would keep employed over 3000 men and feed the large families dependent on them; would prevent about \$2,000,000 annually paid out from leaving the country never to return, or, in other words, with an import duty we would increase the population of our country many thousands; would increase our wealth many millions; would tend towards a steadier and more uniform market and greater stability in all things connected therewith. All this at a cost of what?

The figures given above show that the cost cannot possibly exceed \$200,000. We feel satisfied that it would cost the consumer absolutely nothing and that other benefits accrue therefrom that make the cost nil to the settler, under the most unfavorable point of view.

The only argument that seems to be advanced against an import duty on lumber by the Eastern lumbermen is the probability of the Americans increasing the present duty on lumber going into the United States. This there is little fear of, as conditions have changed so within the past fifteen or twenty years that any increase in the American import duty would now be paid by the consumer in the United States. Their white pine, basswood, etc., and such lumber as is used in the box trade, has practically disappeared and they must now look to Canada for their supplies. The Southern pine and Douglas or Oregon fir is unsuitable for the box trade, and spruce that in the past filled a large part of the box trade and still fills a portion of it, is fast disappearing from the market as sawn lumber and is being utilized instead or held for pulp and paper purposes, where more labor can be given our working classes and more money made out of it. Furthermore, the United States customs laws provide for a drawback of duties on raw material imported and re-exported in further manufactured form, of the duty paid less 10 per cent., and I am credibly informed that the amount of lumber that thus passes through the United States from Canada is much greater than is generally supposed. If this is the case even the doubling of the American duty could not materially affect the Eastern Canadian manufacturer, even if conditions were not as already stated above.

LUMBER DISPUTE SETTLED.

The case of the Rat Portage Lumber Company against the Canadian Northern Railway, which promised to be one of especial interest before the railway commissioners at the recent sitting in Winnipeg, was not heard, the parties having reached an amicable settlement. The lumber company complained that the railway company had not supplied cars when required to haul saw logs from Rainy River to Winnipeg, and in consequence they had suffered great loss in not having material for their mill.

THE STEAM TENSION BAND MILL.

Realizing the advantages that would be possessed by a band mill in which the weight tension could be replaced by a straining system operated by steam, saw mill machinery manufacturers have been trying for some years to provide such a device, but up to the time this mill was put on the market, none of these attempts had proved very successful.

The mill shown herewith was first introduced into the United States about four years ago, where it immediately sprang into favor on account of its simplicity of design and easy and successful operation. Its manufacture has lately been taken up in Canada by the Wm. Hamilton Manufacturing Company, of Peterborough, and we understand it is proving as popular in this country as in the United States, the lumbermen

be instantaneous, and consequently the saw will always be kept in proper tension to do its best work.

Another very valuable feature of this mill is the speed with which saws can be changed on same. Saws of unequal length may be substituted in the same time as saws of equal length. All the time required in this operation is what it actually takes to handle the saws, as, on this mill, the strain can be taken off the saw, the top wheel lowered and raised again throughout its whole range of movement, and the strain put on again, all in less than ten seconds.

The top guide is moved up and down by a steam cylinder located on back part of frame, and so constructed that the piston will be automatically locked in position the instant the valve lever is released.

All mechanism for tilting, raising and lowering the

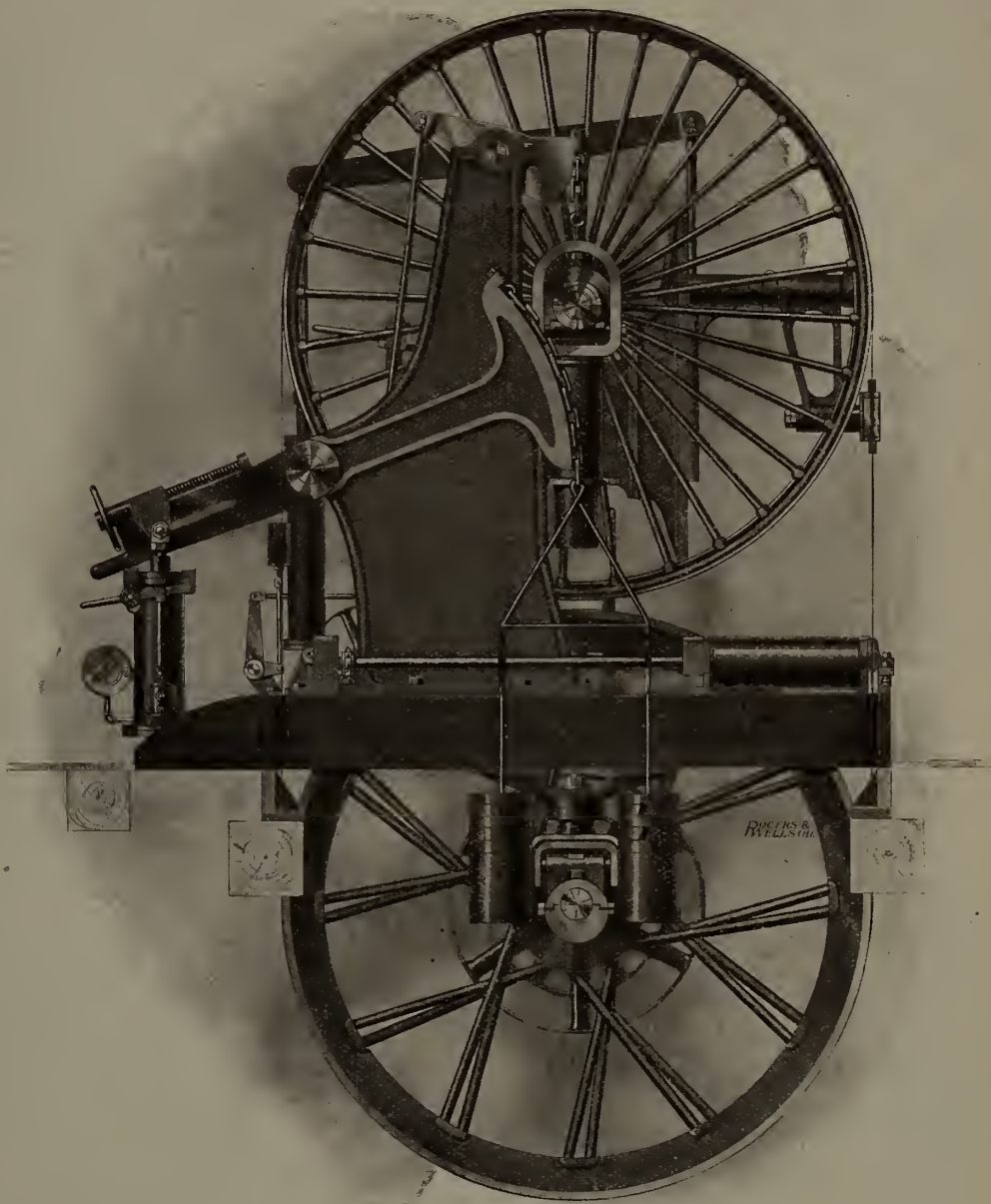

STEAM TENSION BAND MILL MANUFACTURED BY WM. HAMILTON MANUFACTURING CO.

fully appreciating its many time and labor saving qualities.

As has been said, this steam tension device takes the place of the old system of levers and weights, and it is well known that the action of a weight—especially one as heavy as must be used in the tension mechanism of a band mill—is necessarily slow on account of its inertia. In order to get the best results in sawing, the tension device should be very sensitive and capable of responding instantly to the varying demands of the work. As it is manifestly impossible for any form of weight tension to adequately meet these requirements, this mill has been supplied with a direct acting steam cylinder, so arranged that the strain on the saw can be varied at will from 3,500 pounds up to exactly the required amount. Ample provision is also made to enable a practically equable strain to be carried on the saw under varying boiler pressures.

It will be evident to anyone familiar with the use of steam, that the action of this saw straining device must

top wheel is overhead and entirely out of the sawdust and dirt.

The mill is also made very strong, heavy and rigid, and is capable of handling any logs that can be cut by mills of the same size. There is no complicated mechanism about it, and it does not require more attention than any other type of band mill. It is made in three sizes, with eight, nine and ten foot wheels.

Any person requiring detailed information in regard to this mill, can obtain same by writing direct to the Wm. Hamilton Manufacturing Company at Peterborough, Ont., or Vancouver, B.C.

The Miller Manufacturing Company, of Parry Sound, Ont., was incorporated last month, with a capital of \$45,000, to manufacture the Miller adjustable gang saw, the invention of G. B. Miller. The provisional directors of the company are: G. G. Gladman, G. B. Miller, C. A. Phillips and David Macfarlane.

THE Wood-Worker and Retailer

POWER REQUIRED FOR WOODWORKING MACHINES.

Some interesting tests carried out in order to ascertain the power required by various wood-working machines are recorded in the Electrician, an English journal. All the machines were fitted with electric motors by Electro-Motors, Ltd., some of the tests being made with an electromotive force of 460 volts, and the remainder with an electromotive force of 214 volts. The ease and exactitude with which the power required by machines can be determined when they are electrically driven are well known, and offer inducements for carrying out such tests.

It was found in the trials that a circular saw driven at about 1,000 revolutions per minute by a 12-h.p. motor, and taking a cut at the rate of 6 feet per minute on 10-inch by 7-inch damp pitch pine, required 13.8-h.p. Another circular saw, 19 inches diameter, driven by a 7-h.p. motor, required 2.14-h.p. when running light. When cutting deal with a 2-inch cut, at the rate of 6 feet 2 inches in 10 seconds, 5-h.p. were required. With a 1 1/4-inch cut 4 feet 2 inches were sawed in 5 seconds, and required 4-h.p.; with the same cut, a length of 7 feet 3 inches was sawed in 8 seconds, with a horse power of 4.3; while with a 6-inch cut 5.2-h.p. were needed to saw a length of 2 feet in 20 seconds. A 5-h.p. motor, running at 1,200 per minute, and driving a band saw and a vertical spindle machine by means of two belts taken off one pulley, developed, when driving the belts alone, 1.48-h.p., and when driving the two belts and the band saw running light, the power required was 2.14-h.p. The speed of the hand saw was 4,800 feet per minute, and that of the vertical spindle about 4,000 revolutions per minute. Another band saw driven by a 3 1/2-h.p. motor, at a speed of 3,600 feet per minute, took 1.3-h.p. when running light, but when making a 6-inch cut in deal, 2.58-h.p. were needed when sawing 2 feet in 25 seconds. With a 2-inch cut in mahogany, 2.14-h.p. were required for sawing 1 foot in 4 seconds; for a 4 3/4-inch cut in oak it took 3-h.p. to saw at the rate of 1.5 feet in 15 seconds, while a 2 3/4-inch cut in beech took 2.86-h.p. when 1 foot was sawed in 15 seconds.

A tenoning machine, driven at 5,700 revolutions per minute by a link belt from a 5-h.p. motor, took 3.4-h.p. when running light, and 5.86-h.p. when tenoning pitch pine and removing 3 1/2 cubic inches of wood in 10 seconds. A planer, designed for 8-inch by 24-inch planks, and driven from a 5-h.p. motor, took 3.4-h.p. in making 1/8-inch undercut in pitch pine 9 inches wide, and finished a plank 8.5 feet long

in 25 seconds. A 1/4-inch overcut from a plank of pitch pine 5 inches wide required 3.2-h.p. when finishing a 6-foot length in 20 seconds. Another planer, designed for 20-inch by 8 inch planks, and driven by a 5-h.p. motor, required 4.3-h.p. when making a 3/16-inch cut from a 9-inch wide deal plank at a speed of 7 feet 2 inches in 45 seconds; and it took 4.6-h.p. when making a cut 3/32-inch deep off an 18-inch wide deal plank at the rate of 3 feet 8 inches in 17 seconds. An emery wheel used for grinding tools, and running at 1,640 revolutions per minute, required 0.43-h.p. when not grinding; but when working on a straight molding cutter the current ranged from 0.616-h.p. to 1.25-h.p. A 6-inch emery wheel, driven at 1,860 revolutions per minute from a 2 1/2-h.p. motor, took 0.72-h.p. for the motor and belts only, 1.3-h.p. with the emery wheel running light, and 1.6-h.p. when grinding a molding cutter.

GRADING OF BOXES.

At the semi-annual meeting of the National Association of Box Manufacturers held at Niagara Falls, N. Y., last month, the report of the committee on uniform grades was presented by Mr. Chas. E. Turner. Among other things, Mr. Turner said he believed that just as many boxes would be sold to-day if prices averaged from \$1.50 to \$2 per thousand higher. There is just as much lumber sold today, he contended, as there would be if lumber ranged from \$2 to \$3 per thousand lower. But the lumbermen's methods of selling force the highest level, while box makers' methods force the lowest level. He thought that perhaps 75 per cent. of the boxes made are one grade, and are found in grade No. 2. The committee recommended the grading of boxes because uniform prices cannot be had unless there are uniform values. It recommended uniform methods of figuring contents of boxes, for otherwise standard values could not be established. It held that boxes of like grade turned out from factories working under like conditions for lumber value and labor values should bring the same prices, and that those factories are entitled to a reasonable manufacturers' profit. Continuing, he said it was as easy to grade a box by its general characteristics as it is to grade a No. 3, a No. 4 or a No. 5 board, and there should be no greater disparity in the prices of boxes than there is in the prices of lumber.

The grading conclusions of the committee were as follows:

GRADE NO. 1, STYLE NO. 1.

Lumber in this grade of boxes must be clean and smooth appearing. Shall contain no rot, coarse knots, shake, wane or wormholes.

Examples:—Pine boxes matched and printed f. o. b. Wausau. Base rate, \$24.35.

No.	Length.	Width.	Depth	Bd. Ft.	Price.	%-3/8
1	18	13	9 7/8	5.10	12.42	7/8-3/8
2	18 3/8	8 3/4	10	3.95	9.62	"
3	28 7/8	8	7 3/4	3.72	9.05	"
4	14 7/8	10	9	3.53	8.60	"
5	28 3/4	5 7/8	6	3.20	7.80	"
6	17 1/2	9	10 5/8	4.05	10.27	"
7	17	9 1/4	10 7/8	4.12	10.45	"
8	15 1/4	10	8 3/4	3.52	8.92	"

Remarks:—Lumber No. 3, \$15.00; Waste, 15 per cent; Workbill, \$4.00; Manufacturer's profit, \$2.00.

NOTE:

Boxes 1 pc. side and end 5 to 5 1/2 in. deep.
Boxes 1 pc. side and end 6 1/4 to 7 1/2 in. deep.
Boxes 1 pc. side and end 8 1/4 to 9 1/2 in. deep.
Boxes 1 pc. side and end 10 1/4 to 11 1/2 in. deep.
(Add \$1.00 per 1,000 to base rate.)

GRADE NO. 2, STYLE NO. 1.

Lumber in this grade of boxes may contain the following defects, but not enough to detract from the appearance of the box or weaken the pieces. Some sound rot, shake, sound knots and wormholes.

Examples:—Pine boxes matched and printed f. o. h. Wausau. Base rate, \$22.65.

No.	Length.	Width.	Depth	Bd. Ft.	Price.	%-3/8
1	18	13	9 7/8	5.10	11.55	7/8-3/8
2	18 3/8	8 3/4	10	3.95	8.95	"
3	28 7/8	8	7 3/4	3.72	8.43	"
4	14 7/8	10	9	3.53	8.00	"
5	28 3/4	5 7/8	6	3.20	7.25	"
6	17 1/2	9	10 5/8	4.05	9.58	"
7	17	9 1/4	10 7/8	4.12	9.75	"
8	15 1/4	10	8 3/4	3.52	8.32	"

Remarks:—Lumber, \$12.00; Waste, 20 per cent; Workbill, \$5.50; Profit, \$2.00.

NOTE:

Boxes 1 pc. side and end 5 to 5 1/2 in. deep.
Boxes 1 pc. side and end 6 1/4 to 7 1/2 in. deep.
Boxes 1 pc. side and end 8 1/4 to 9 1/2 in. deep.
Boxes 1 pc. side and end 10 1/4 to 11 1/2 in. deep.
(Add \$1.00 per 1,000 to base rate.)

GRADE NO. 3, STYLE NO. 1.

Lumber in this grade of boxes may contain the following defects: Sound rot, some soft rot, coarse knots, wane, wormholes and shake, but the defects above named shall not be so numerous as to materially weaken the box.

Examples:—Pine boxes matched and printed, 1 or 2 pc. sides f. o. b. Wausau; base rate, \$18.85.

No.	Length.	Width.	Depth	Bd. Ft.	Price.	%-3/8
1	18	13	9 7/8	5.10	9.62	7/8-3/8
2	18 3/8	8 3/4	10	3.95	7.45	"
3	28 7/8	8	7 3/4	3.72	7.00	"
4	14 7/8	10	9	3.53	6.65	"
5	28 3/4	5 7/8	6	3.20	6.05	"
6	17 1/2	9	10 5/8	4.05	7.65	"
7	17	9 1/4	10 7/8	4.12	7.75	"
8	15 1/4	10	8 3/4	3.52	6.67	"

Remarks:—Lumber, \$9.00; Waste, 20 per cent; Workbill, \$4.50. Profit, \$2.00.

NOTE:

Boxes 1 pc. side and end 5 to 5 1/2 in. deep.
Boxes 1 pc. side and end 6 1/2 to 7 1/2 in. deep.
Boxes 1 pc. side and end 8 1/4 to 9 1/2 in. deep.
Boxes 1 pc. side and end 10 1/4 to 11 1/2 in. deep.
(Add \$1.00 per 1,000 to base rate.)

GRADE NO. 4, STYLE NO. 3.

(Cleated.)

Lumber in this grade of boxes may contain many defects, such as soft red rot, knotholes, wormholes, shake; in fact, anything that will hold a nail and will carry the contents.

Examples:—F. o. b. Wausau; base rate, \$17.50.

No.	Length.	Width.	Depth.	Bd. Ft.	Price.
	36 1/2	34	34 1/2	60.53	105.93
	48	34	34 1/2	71.75	125.56
	52	37 1/2	34 1/2	80.32	140.56
	39 1/2	37 1/2	34 1/2	67.52	118.36
	37	13	13	10.50	18.38
	37	25 1/2	13	16.00	28.18

FOR THE CAMP

We have a very suitable lot of goods for camp supplies. We make this kind of trade a specialty. You who are not getting suited just as well as you would like, try us for your next order, and give us a chance to demonstrate our ability to give you satisfaction in this very important department of your business.

H. P. ECKARDT & CO.

Wholesale Grocers

TORONTO

Remarks:—Lumber, \$7.00; Workbill, \$4.50; Waste, 25 per cent.; Profit, \$2.15.

Terms:—Sixty days, or 2 per cent. discount for cash within 10 days from date of invoice. The discount applies only to net amount of invoice after deducting freight from delivered prices.

AMERICAN IMPROVED 10-IN. FOUR-SIDED MOULDER.

The improved four-sided moulder illustrated herewith is a very heavy machine, capable of working mouldings 10" wide, 5" thick, on four sides. The frame is cast solid in one piece, well braced and perfectly rigid, with

lowered 12" on ball bearings. The tail-piece in rear of under head swings vertically out of the way.

The top head has a lateral adjustment, while the under head has lateral and vertical adjustments, and is provided with sliding throat-plates and chip-breaker in the table. The journal boxes are placed on an incline so that the belts pull more on the bottom of the boxes.

The inside and outside head-stocks have vertical and horizontal adjustments and may be set to an angle. They are both attached to the table, avoiding any possible vibration. The inside head is provided with chip-breaker and take-up, and the outside head has an adjustable spring chip-breaker. Both spindles run on

be furnished by the American Wood Working Machinery Co., the Levi Houston Co. branch, Liberty street, New York.

MAKING FLOORING.

I note that one writer says it is very difficult to make flooring, surfaced both sides and tongued and grooved, all at one running. Nearly all the flooring made in the south is worked this way, and I never heard a man complain of having any trouble to keep the machines in adjustment. I have been running flooring this way for several years, and have been having no trouble with the matching. I think that if a planing mill cannot

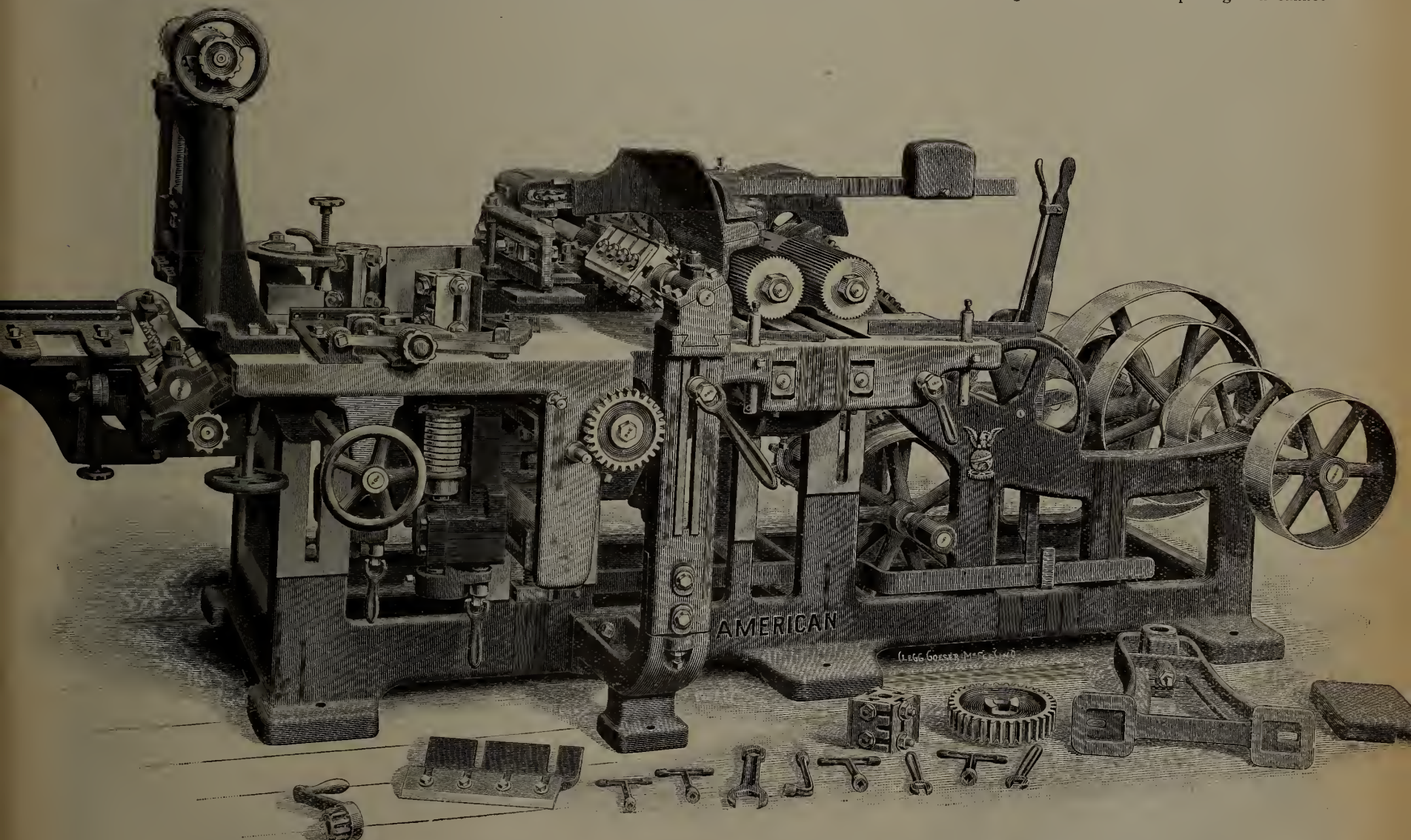

AMERICAN IMPROVED 10-IN. FOUR-SIDED MOULDER, MANUFACTURED BY THE AMERICAN WOOD-WORKING MACHINERY COMPANY.

all working parts easily accessible. An outside bearing is provided for the top arbor, firmly clamped to the frame, and is adjustable for lining up when necessary.

The feed consists of two 5½" top rolls and two 6" bottom rolls, all powerfully driven by heavy gearing. The top rolls are raised by means of a lever which permits the operator to place a form for setting the knives and withdrawing the work from the cutters when desirable.

The table is clamped to the frame at the front end, at the outside bearing and at the rear end, and may be

self-oiling steps. All cylinder pulleys are pneumatic. The hood over the top head is adjustable to and from the cutters, and the pressure-foot or chip-breaker is hinged on the hood, with springs in the hinge to avoid vibration. The pressure-foot in rear of top head is sectional, adjustable horizontally and vertically, hinged, and can be swung over the top of frame. The pressure-foot over under head is also sectional, and is fastened to table independent of frame, thus preventing all vibration.

Further particulars regarding the above machine will

make "S. 2 S." flooring successfully without running the lumber twice, it needs a new foreman.—J. H. MILLS, JR., in Woodworker.

STANDARD APPLE BOX.

In June, 1906, an act making a uniform sized apple box will become effective in Canada. This box is ten by ten by twenty-two inches inside measure; it contains twenty-two hundred cubic inches, which is one bushel or about one-third of a barrel. Smaller sized boxes are recommended for South Africa, France and Germany.

THE NEWS

ONTARIO.

—A. K. Van Wyck is offering for sale his planing mill at Parkhill, Ont.

—A new box factory will be built by the London Box Company, London, Ont.

—Ledingham & Son have just completed improvements to their saw mill at Alma, Ont.

—The R. Laidlaw Lumber Company are building a large planing mill on Dundas street, Toronto.

—E. Wand has purchased the planing mill at Peterboro, Ont., recently operated by R. Clinkscale.

—It is understood that Boyd Bros. and T. L. Blakely have purchased the Wilson planing mill at Flesherton, Ont.

—The Rat Portage Lumber Company's steamer "Monarch" was recently damaged by fire to the extent of \$2,000.

—The Dickson Company are said to be considering the erection of a planing mill in connection with their saw mill at Peterboro, Ont.

—J. B. Smith & Sons, Toronto, have recently installed a steam tension band mill in their saw mill at Callendar, Ont., supplied by the William Hamilton Manufacturing Company.

—R. Nuttel is building a saw mill at Devlin, Ont., to which place he will remove his machinery from Sturgeon River. It is the intention to manufacture lumber, barrel staves and heading.

—Alex. MacBeath, of Kippen, Ont., recently returned home from a visit to his newly acquired timber limit near North Bay, Ont. He selected the site and next year intends building a mill.

—It is said to be the intention of the Cleveland-Sarnia Saw Mills Company to build a match factory. This company will, according to report, operate their saw mill all winter, bringing in the logs by rail.

—The long-standing suit between Milton Spears, of Powassen, and the Huntsville Syndicate, of Huntsville, in connection with lumber deals made in 1899 and 1892, was amicably settled last month. Both parties were apparently satisfied with the compromise.

—The Long Lake Lumber Company, Limited, has recently been incorporated, with a capital of \$40,000, the head office being at Toronto, although operations will be carried on in the district of Parry Sound. The directors include H. E. Hurlburt and George W. Hurlburt, both of Novar, Ont.

—J. R. Booth, Ottawa, has recently purchased from Robb Engineering Company, Limited, Amherst, N.S., two 400 h.p. Robb-Armstrong Corliss engines, one 350 h.p. Robb-Armstrong Corliss engine and three 100 h.p. Robb-Armstrong Corliss engines. This machinery is for Mr. Booth's new paper mills.

—The Canadian Cooperage Company are doing a nice business at Galetta, Ont., in the manufacture of

cooperage stock. They are figuring on putting in a complete plant for the making of hoops and heading, so that in 1906 they expect to be making all kinds of slack cooperage stock, and can then supply mixed car orders, for which they find considerable demand. The manager is H. D. Chapman.

—The Preston-Bell Furniture and Lumber Company, of Fort Frances, Ont., are considering the project of establishing a pulp mill on Rainy Lake in connection with their lumbering enterprises. The company control a water power capable of developing eight hundred horse power, and it is their intention to use this to operate the pulp mill. A mill for manufacturing building paper may also be established.

—The Opemican River Improvement Company, Limited, has been organized, to construct improvements on the McDougall, Opemican and Ottetail rivers, in the district of Nipissing. The capital is \$35,000 and head office at Hawkesbury, Ont. The provisional directors are well-known lumbermen, including W. C. Edwards and John A. Cameron, of Rockland; Hiram Robinson, Hawkesbury; and H. K. Egan, R. L. Blackburn and R. G. Cameron, of Ottawa.

THE EASTERN PROVINCES.

—The Improved Match Company are to begin operations at once at Drummondville, Que.

—Walso Hobart has registered as proprietor of the lumber business of Hobart & Company, Montreal.

—A. W. Giard and Mederic Faucher will conduct a lumber and general store business at La Patrie, Que.

—Mrs. A. G. Munich has registered as proprietress of the business of the Montcalm Lumber & Wood Company, Montreal.

—W. J. Carnwath, of Hopewell Hill, N.B., will operate a saw mill this winter on timber property at Memel recently purchased from Howard Stevens.

—H. P. Boles, who recently installed a rotary in his saw mill at Centre, N. S., met with the misfortune of having his mill destroyed by fire last month.

—Primrose Bros. have completed sawing for this season at Liverpool, N.S., and have removed their mill to Chester. The lumber has been shipped to New York.

—The Haskill Lumber Company, of Fassette, Que., have recently purchased a new locomotive for hauling logs. It will be operated on the Salmon River and Northern Railway.

—The business of the Ivy Manufacturing Company, Limited, cooperage materials, Montreal, has been registered. The proprietors are Arthur N. Paiton and William C. Jarvis.

—The Tracadie Lumber Company's saw mill at Sheila, N. B., which was burned last month, consisted of a

band mill with band resaw, circular saw, three clap-board machines, box board machine, a complete box board shoo plant and a planing mill. The mill was one of the most complete in the province. The Tracadie Lumber Company was organized at Bangor, Maine, in 1897, the officers being: President, F. W. Hill; secretary treasurer, L. C. Tyler; general manager, R. H. Wing.

—T. E. Babbitt & Sons have completed their saw mill at St. Mary's, N.B. The main part of the mill is 30 x 100 feet, with a stone engine house 18 x 40 feet, of fireproof construction. The plant at present consists of a rotary, shingle machine, planer, matcher and moulder. In addition to the mill buildings they have erected a neat business office, machine shop, lumber sheds and a large tenement house. It is understood that they have also under consideration the erection of a sash and door factory.

—In accordance with the desire to have the boundary between the Province of Quebec and Newfoundland's coast strip, along the Labrador peninsula, clearly defined, the Quebec Government, with the approval of the Federal authorities, will take steps to have the matter settled in the courts. Newfoundland some time back issued timber licenses in the interior of Labrador. Premier Gouin's intention is to have some of this timber seized, after which the courts will be asked to say whether the Island colony has any right to issue licenses under which the lumbermen operate.

—A meeting of the directors of the Chimalapa Land Company was held in Montreal early in October, when it was decided to proceed with the erection of mills. This company, as stated in a previous issue, have acquired large timber areas in Mexico, the intention being to export the lumber to Europe, the United States and probably to Canada. The erection of a veneer mill at St. John, N.B., is said to be under consideration. George W. Fowler, M. P., of Sussex, N. B., and F. H. Hale, ex-M.P. of Woodstock, N. B., have gone to Mexico to superintend operations. Others interested in the company are: James Robertson, Montreal; R. G. Haley, St. John, N.B.; Wm. A. Marsh and John Ritchie, Quebec; P. H. Hale, Enderby, B. C.; James T. White, New York; Judge McCrimmon, Whitby; A. W. Wright and J. A. McIntosh, Toronto, and Shearer, Brown & Wills, Montreal.

MANITOBA AND THE TERRITORIES.

—Higgs & Hopd have opened a lumber yard at Paynton, N. W. T.

—T. A. Burrows, M. P., intends building a saw mill near Grand View, Man.

—W. L. Martin has re-engaged in the lumber business at Wapella, N. W. T.

—S. V. Bray, lumber dealer, Wolseley, N. W. T.,

TENTS

That are the acme of perfection, in all details of work. BRITISH ROYAL NAVY method of cut, workmanship and finish. MATERIAL used made in SCOTLAND by the Navy Contractors. Samples and prices are mailed on request.

TOBIN TENT & AWNING CO. OF OTTAWA Long distance phone No. 432

CRAIG MINE CRYSTAL CORUNDUM WHEELS

Our Pure Crystal Corundum Saw Gummars have no equal for their Rapid, Cool, Cutting Properties.

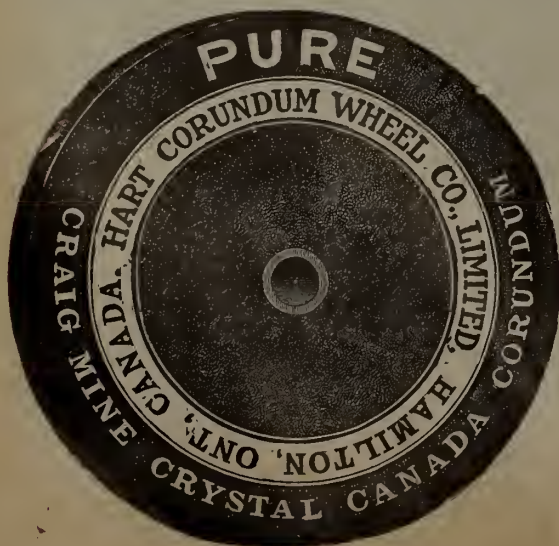

Read the following from Bulletin 180 of the United States Geological Survey, which says:

"Often a distinction is made between emery and corundum, many persons not recognizing emery as a variety of corundum.

Emery is a mechanical admixture of corundum and magnetite or hematite. It is, of course, the presence of corundum in the emery that gives to it its abrasive qualities and makes it of commercial value, and the abrasive efficiency of emeries varies according to the percentage of corundum they contain."

Emery is imported, mined by Greeks and Turks and contains only about 25% corundum. Our Crystal Corundum is guaranteed to be 98% pure alumina, a Canadian product, mined and manufactured by Canadians for Canadians.

HART CORUNDUM WHEEL COMPANY, Limited, Hamilton, Ont, Can.

has been succeeded by the Independent Lumber Company, Limited.

—Miller & Robinson have opened a lumber yard in Lloydminster, Saskatchewan.

—Moler & Peplar, Wetaskiwin, N. W. T., have sold out their business to the Rosenroll Lumber Company.

—D. R. Fraser & Company are building a large burner at their mill at Edmonton, N. W. T., to consume the sawdust and other waste material.

BRITISH COLUMBIA.

—Thomas Leask, who is building a sash and door factory at Cranbrook, B. C., expects to have it in operation at an early date.

—The Ladysmith Lumber Company's mill near Kimberly, B.C., will probably be completed this month. New boilers and other improved machinery have been installed.

—A. G. Laulbert & Company, of Nelson, B. C., are now operating a mill of their own on Slocan river, manufacturing their own stock for their retail lumber yard in that city.

—The Adair Manufacturing Company has been organized, with a capital of \$75,000, to manufacture the Adair patent stump burner. A factory will likely be built at Revelstoke.

—The Revelstoke Lumber Company, who recently lost their mill at Revelstoke, B. C., will rebuild a little east of the old site. C. F. Lindemark is the enterprising manager of this company.

—Walter Gilley is building a new wharf at New Westminster, B. C., for the Fraser River Sawmills, Limited, the intention being that vessels shall load lumber at this port as was the case a decade ago.

—The Red Cedar Lumber Company, whose saw mill at Cedar Cove, B. C., was destroyed by fire a few weeks ago, have the work of rebuilding well under way. New machinery has been purchased, as practically all the old equipment, with the exception of the boilers, was destroyed.

—The Dickason-Goodman Lumber Company, of Kansas City, Mo., who recently purchased the lumber property of W. C. Wells, M.P.P., Palliser, B.C., intend considerably enlarging the mill. It is stated that they will also establish a chain of independent lumber yards throughout the Northwest.

—The Arrowhead Lumber Company, of Arrowhead, B. C., which is expected to be sold shortly to American capitalists, have a very complete plant, consisting of a double cutting band and a large gang saw, planing mill with four planers, two matchers, flooring machines, dry kilns, lath machines, etc.

—The Bowman Lumber Company, Comaplix, B. C., recently cut a tree that graded 12,000 feet board measure. At the new Mundy Lumber Company's plant at Three Valley Lake, 15 miles west of Revelstoke, it is reported that they are cutting down trees that run eight and nine logs to the tree.

—All the lumber at the Otis Staples mills at Bayard B. C., is sorted by Chinamen, the grader being a white

man. The Chinamen elect their own foreman, and sort the lumber deftly and quickly, placing it on the tram cars and keeping the platforms clear. It is noticeable that they learn the grade marks very quickly, and that all their work is done in silence and without any confusion.

—The Kootenay River Lumber Company, of which Mr. Genelle is manager, are operating at Nelson, B.C., cutting principally western pine, fir and larch, with a small percentage of cedar. They have some excellent cottonwood (or whitewood as some call it) tributary to their mills. This wood is expected to become of great value for buggy or cutter stock, also for the manufacture of fanning mills and like purposes.

—Minnesota capitalists, presumably the Weyerhaeuser interests, have purchased 43,000 acres of timber lands on the eastern coast of Vancouver Island, B.C. The tract, which contains a vast quantity of standing fir and cedar of the best quality, is located between the Salmon and Campbell rivers. The purchasers are planning the erection of a saw mill in Vancouver with a capacity of 70,000,000 feet per annum.

—The Seattle Cedar Manufacturing Company are establishing mills on the west coast of Vancouver Island, B. C. The mill will be the largest cedar mill in the world, having a capacity of 380,000 shingles every ten hours. The main mill plant, which will cost \$500,000, will be built on Mosquito Harbor, Mears Island, while the smaller mill plant, which will cost \$50,000, will be situated on Nootka Sound. The company will build a large wharf a mile long, and will have their own steamers. The company have sufficient timber to last for twenty years.

—The Canadian Timber & Saw Mills, Limited, of Trout Lake, B. C., which recently resumed operations, under the management of J. D. Kennedy, contemplate making extensive alterations and improvements to their plant, including the installation of additional machinery. The lumber that is at present being manufactured will be used chiefly in the work of re-construction. It is the intention to build a new dry kiln of generous proportions also. The whole company is being re-organized in order to provide the necessary funds for the contemplated improvements.

—The Yale-Columbia Lumber Company and the Kootenay River Lumber Company, both in British Columbia, amalgamated during the latter part of September, under the name of the Yale Columbia Lumber Company, Limited. The personnel of the new company is the same as that of the Yale-Columbia Company previous to the amalgamation. The Yale-Columbia Lumber Company, Limited, own and operate four different saw mills, at Nakusp, Westley Cascade and Nelson, giving a total cutting capacity 175,000 feet per day of ten hours.

—Duluth and Superior parties are reported to have just secured an option to buy the timber limits and saw mill of the Arrowhead Lumber Company at Arrowhead, B. C. The deal involves \$650,000. The timber consists of a billion feet, principally cedar, and the saw mill has a capacity of 200,000 feet a day. The property was thrown on the market after the death of President McLeod, of typhoid, and of Manager Beatty, a victim of a fire in the mill boarding house last February. The probable buyers are A. Gowan and C. L. Twohey, of Duluth; Thomas Kileen, of Superior, and James B. McCormick and A. C. Underhill, of Rutledge, Minn. Mr. McCormick is slated for the management.

—The present mill of the Bowman Lumber Company at Comaplix, B.C., is shortly to be replaced by a new and modern mill of much greater capacity. The company intend to install a double-cutting band mill, with live rolls and the very latest machinery equipment, the whole to be operated by new steam power plant. This mill, with their present plant at Revelstoke, will give the company a cutting capacity of over 200,000 feet per 20 hours. They are also contemplating extensive improvements to their Revelstoke mill. The Bowman Lumber Company have their own car ferry service operating across the upper end of the Arrow Lake between Comaplix and Arrowhead, thus giving them direct railroad shipping facilities in connection with their mill. The ferry is large enough to carry six loaded freight cars each trip. Besides this they operate a passenger and mail boat from Arrowhead to Comaplix and Beeton, at the head of the Lardo mining district, also running their own general store at Comaplix, which carries a complete stock of everything in the way of supplies.

—The Arrowhead Lumber Company, of Arrowhead, B.C., intend increasing the capacity of their planing mill by about two-thirds its present capacity in order to handle the full product of their saw mill. The planing mill was built for handling the product of their band mill, but since the addition of the gang saw it is inadequate for the mill output. The work of increasing the capacity of their steam plant, which may mean the addition of another boiler, will also be gone ahead with. Two more dry kilns of over 50,000 feet capacity each will be erected this winter. Work is at present under way on the extension of their yard accommodation, and piling is being driven in along the edge of the lake for over one-eighth of a mile. The electric lighting system is being extended down the entire length of the yard to permit of piling and shipping at night time and giving a longer working day during the winter. They have recently completed the extension of their water-works system and pumping plant, with water mains running to all parts of the mill property. The normal pressure on the water main is approximately 100 lbs. which can be easily raised to 250 lbs. if needed by the operating of the three large pumps in the mill. A tank with a capacity of 60,000 gallons is located on the hill immediately above the mill.

RAILS and TRACK SUPPLIES

NEW and Re-Laying from 12 to 60 lbs. per yard with fastenings; for Lumbering, Mining and Contracting Work. Immediate shipment from Stock. Get our prices before purchasing.

SESSENWEIN BROS.,
101 Shannon Street, Montreal

CONSULT YOUR FILER . . .



Hanchett Circular Saw Swage

about that new swage or swage shaper you are going to buy, and if he has never used our tools just drop us a line and we will gladly send free for 30 days' trial one of our

HANCHETT ADJUSTABLE SAW SWAGES OR SWAGE SHAPERS

The Hanchett Swages have stood the test of years. They are standard make, and a customer who purchases one knows he is getting the best money can buy. Sold with unqualified guarantee.

Send for our new Catalogue "F". It tells all about our Saw Swages and Swage Shapers. Free for the asking.

Manufacturers of complete outfits for the filing room.

HANCHETT SWAGE WORKS, BIG RAPIDS, MICH., U.S.A.

FORESTRY DEPARTMENT

MICHIGAN FORESTRY ASSOCIATION.

The Michigan Forestry Association was recently organized at a convention at Grand Rapids. The officers chosen were as follows: John H. Bissell, Detroit, president; Thornton A. Green, Ontonagon, vice-president; T. M. Sawyer, Ludington, secretary, and John J. Hubbell, Mainstee, treasurer. The Board of Directors for one year includes: Mrs. Louisa A. King, Alma; Hon. C. J. Monroe, South Haven; Dr. L. L. Hubbard, Houghton; Walter C. Winchester, Grand Rapids; H. N. Loud, Au Sable; Hon. Geo. B. Horton, Fruit Ridge. With the election of these able officers and directors, the Michigan Forestry Association becomes a fact and not a theory.

Probably no movement in the state has brought out a more generous response than this project. Hon. Arthur Hill, a member of the commission, has visited Europe for the purpose of studying forestry conditions there, and refuses to use any of the state appropriation for his expenses. More time and thought has been given to this work than the promoters will ever admit.

The convention was presided over by the Hon. Arthur Hill of Saginaw, Thornton A. Green, the prominent lumberman of Ontonagon, while Prof. Roth, of Ann Arbor, state forest warden, and Hon. Chas. W. Garfield of Grand Rapids, president of the Michigan Forestry Commission, were active spirits.

The convention was held at the Park church, the entrance and interior of which were appropriately decorated by the liberal use of the state forestry exhibit used at the St. Louis fair, now a part of the Kent museum at Grand Rapids. The room was hung with placards bearing pertinent inscriptions, among which were:

"It takes thirty years to grow a tree, and thirty minutes to cut it down and destroy it."

"A country without wood is a house without a roof."

"Next to the earth itself, the forest is the most useful servant of man."—Pinchot.

On the back of the program appeared the following paragraphs, giving the facts con-

cerning Michigan's denuded lands and stating the plans and purposes of this much needed association:

The original forest of Michigan was among the finest in the world. It suggested the motto upon our shield.

Part of this destruction was necessary in the interest of the settlement. Much of it was inexcusable waste, for scarcely one-half of the state is settled and a scant one-third of the land is improved.

About one-third of the state is cut and burned over—an unproductive waste area. Every acre of this might and should bear a forest cover, growing a dollar's worth of timber every year.

More than six million acres of this area is state tax lands.

This enormous loss appeals to our people. They demand that something shall be done. The farmer, the business man, the press, all join in this demand.

The state has felt the pressure of this demand and made a start. It has improved the fire laws; it has set aside a small portion of these lands as a permanent forest reserve.

To increase this reserve; to gather and spread information in the interest of a permanent forest policy; to awaken an abiding interest in reforestation, is the message as well as the duty of the Michigan Forestry Association.

CHAIRMAN'S REMARKS.

"When I was a boy," said Chairman Hill, "my father had a mill on Saginaw river, and all his logs were taken from booms across the river. That was as far as he had to go for timber. Now how remote our forests are, when lumber comes from away across the continent. We are approaching a timber famine. I rode last spring from London to Southampton and within fifteen miles of London there is a young pine forest which is larger than the total pine area in Michigan to-day. France, England and Germany are in the front rank among nations in providing homegrown timber. I visited the cement plant at Elk Rapids recently and it seems to me that anyone who is making cement, or any substitute for lumber, is a public benefactor. One would think with the increasing use of steel, cement, etc., in building operations that the demand for lumber would diminish, but it is not so. The use of lumber is increasing continually. Lumber that was used in house building twenty-one years ago and graded as mill culls at \$4 per thousand is good enough now to go in with the \$30 grade. It is really a crime against the state and its citizens that its denuded lands should remain waste, when they will grow timber."

RESOLUTIONS ADOPTED.

Following are the resolutions adopted:

"Whereas, this association is deeply impressed with the facts that the forests of our state have largely disappeared and the remnants are rapidly disappearing; that millions of capital formerly invested in lumbering and other woodworking interests have left and are leaving the state, and the state is paying large sums in importing lumber and timber materials which our state should grow in abundance; large areas of our lands are in a cut and burned-over waste land condition, involving a loss to our people of millions of dollars every year; the policy and laws of our state act in a way to discourage the holding of reforestation of these lands; the lack of proper protection of forest property has prevented the conservative management of the woodlot farm forest; the state neglects its own lands and thereby hinders the improvement of lands by private effort; the present system of dealing with tax title lands acts in the direction of further timber denudation; and

"Whereas, The Michigan Forestry Association has for its objects the promotion of forestry in all directions; therefore be it

"Resolved, that this association use its best efforts to secure

"Modification of our laws, which will enable the holding and reforestation of forest lands, and encourage conservative management of our farm forests as well as restocking denuded lands.

"Improvement and strengthening of our laws for protection of forest property against fire or trespass.

"Modification of our laws dealing with the disposition and management of our state lands, so that correct principles of forestry may be applied to all wooded areas not distinctly agricultural.

"Continuance and extension of the work of the Michigan Forestry Commission, and that it be provided with ample funds to carry on a more extensive campaign of education among the people.

"That it may be made a prominent part of the work of the association to urge the establishment and perpetuation of a general system of farm forestry throughout the state.

"That this association act in harmony with the American Forestry Association and with the National Bureau of Forestry, realizing that in so doing we will further the cause of forestry everywhere.

"That the newspaper editors and publishers of the state be made honorary members of the association."

The JOHN McDOUGALL CALEDONIAN IRON WORKS CO., Limited
MONTREAL, QUE.



Boilers, Tanks, Filters
MILL MACHINERY, Etc.

Builders in Canada of the Celebrated

"WORTHINGTON" TURBINE PUMPS

AND

"DOBLE" TANGENTIAL WATER WHEELS

General Agents in Canada for the INTERNATIONAL STEAM PUMP CO. and its Companies.

Catalogues on Application

Fires in Lumber and Woodworking Risks

The following table is a summary of the experience of seven lumber insurance companies, all of whom have kept a careful record of the causes of fires in lumber yards and mills. This table is quoted from the September issue of "Lumber Insurance," published at 66 Broadway, New York, by the Lumber Insurers General Agency, managers of three of the leading lumber insurance companies.

Causes of Fires Sustained by Seven Lumber Insurance Companies

Known Causes, Internal	
Back draft or from boiler and furnace.....	45
Sparks from smoke stack.....	17
Sparks from coal stove.....	4
Sparks from refuse pit.....	4
Sparks from emery wheel.....	2
Dust on top or rear of boiler.....	3
Over-heated furnace.....	1
Over-heated kiln.....	3
Spontaneous combustion in shavings vault, packing-room, glazing room or kiln.....	25
Hot box or journal.....	6
Friction of belting over tight pulley.....	3
Defective electric wiring.....	3
Defective heating apparatus, poor flues.....	12
Gasolene explosion.....	2
Gas explosion.....	1
Lamp explosion.....	2
Boiling over of pot of tar on stove.....	1
Slacking of lime caused by high water or floods.....	20
Accumulation of oil through gas main.....	1
Spark caused by metal substance accidentally dropping in refuse grinder.....	1
Smoking.....	7
Carelessness by tramps or others.....	7
Boys' bon-fires.....	3
	173
Known Causes, External	
Lightning.....	24
Railroad locomotive sparks.....	49
Tug or steamer sparks.....	8
Fire crackers.....	2
Woodworker mill exposure.....	19
Livery stable or barn exposure.....	15
Frame row exposure.....	32
Frame elevator exposure.....	23
Flour mill exposure.....	1
Forest exposure.....	7
Spark from burning building across street.....	14
Spark from distant burning building.....	9
Conflagration.....	5
All other exposures.....	45
	253
Incendiarism	
Fires said to have been of incendiary origin.....	66
Unknown Causes	
Fires of unknown origin.....	293
Total.....	785

LUMBER INSURERS GENERAL AGENCY, Inc.

66 Broadway, NEW YORK

Sandusky, OHIO

Combined Cash Assets Over \$700,000.00

Managers of Lumber Insurance Co. of New York, 66 Broadway, New York; Toledo Fire and Marine Insurance Co., Sandusky, Ohio; Lumber Underwriters, 66 Broadway, New York.

Direct applications for insurance on Canadian risks are solicited, and will receive prompt attention. Rates consist with the hazard.



THE NEW VICEGERENT SNARK.

Canadian Hoo-Hoo are permitted to observe on this page the countenance of Mr. R. D. Inman, who was elected Snark of the Universe at the Portland concatenation September 9th. The new Snark is president of Inman, Poulsen & Company, of Portland, Oregon, and an



MR. R. D. INMAN, Vicegerent Snark.

enthusiastic Hoo-Hoo who will doubtless guide the craft through a year of prosperity.

THE LATE JOSEPH TURNER.

Mr. Joseph Turner, president of the Turner Lumber Company, Midland, Ont., died very suddenly in Toronto on Friday, October 27th. Some years ago he conducted extensive lumbering operations in Michigan. He began his career with S. H. Webster & Company, of Bay City, and later formed a co-partnership with the late W. H. Tousey. He was instrumental in having the Blodgett sawmill removed from Muskegon to Bay City. This he operated under the name of the South End Lumber Company, Mr. S. O. Fisher being associated with him in this enterprise.

About 1890, the timber supply of Michigan having become exhausted, he turned his attention to Canada, purchasing limits and operating in the Georgian Bay district. Since that time he has been prominent in Canadian lumber circles and a strong advocate of an import duty on American lumber so as to equalize the conditions. His logging operations have mostly been carried on in the South River district, while the manufacturing has been done at Midland, where the head office for Ontario is located.

No man, perhaps, had a better knowledge of lumbering than the late Mr. Turner. He was a director of the Spanish River and Ausable Boom Company, the French River Boom Company, and the Vermillion River Boom Company. Mr. Turner was prominent in the Masonic order, being a Knight Templar and a thirty-second degree Scottish Riter. Deceased was 56 years old and leaves a widow, a resi-

dent of Bay City, and four sons, all associated with their father in business. They are Dwight J., of Midland; S. F. and Clarence A. of South River, and Arthur B. Turner, of New York city.

STRONG TESTIMONIALS.

The Canada Saw Company, Limited, of Ottawa, are constantly in receipt of letters bearing testimony to the satisfaction given by their saws for both lumber and shingle mills. Two testimonials received this year are reproduced below:

John Fenderson & Company, Incorporated, manufacturers of lumber, shingles and lath, Sayabec, Que., say: "We have tested the band saw shipped us lately on our band resaw against some of the best American makes and are pleased to say that our saw man reports yours the best. Kindly rush lath saws on order."

The Metis Lumber Company, manufacturers of spruce lumber and cedar shingles, Price, Que., express their opinion as follows: "The 10 shingle saws you shipped us last month have been at work now a week, and we are pleased to say that they are giving us evidence of being A1 saws in every respect. They were in perfect order when received, and all without exception fitted on the collars so accurately that there was no need of hammering or retouching them in any way. We are highly pleased with the saws, and your punctuality in shipping them to us. They arrived here on the day preceding the date of shipment specified in the order. As we require immediately four other shingle saws exactly similar to those you have already shipped us, we have wired you to-day to inquire how soon you could furnish them, and hope you may be able to do so promptly. The 66 inch cut-off saws you supplied us are also satisfactory. We may say that this is the first time in our experience that we have been able to express entire satisfaction with any considerable lot of saws that we have bought from Canadian makers."

PERSONAL.

Mr. F. A. Mulholland, of the Imperial Veneer Company, Sundridge, Ont., has gone to Cuba, having been commissioned to purchase a veneer plant for the Cuban Realty Company.

Mr. Henry Milton Martin, of Vancouver, federal Crown land and timber agent for the Yukon, with Messrs. John F. Surgue and J. Sylvester, assistant inspectors, have been suspended from office owing to alleged irregularities.

Mr. A. Byrne, of the Garlock Packing Company, Hamilton, has returned from an extensive business and pleasure trip to Europe. He visited London, Paris and many other of the large business centres, having been absent for four months.

Mr. Edgar C. Baker has ceased to represent Messrs. Smith, Tyer & Company, timber merchants, of Liverpool, Eng., and Mr. Colin Campbell Tyer, who has been associated with Mr. Baker for the last two years, will undertake the management of their Halifax office.

Mr. E. W. Wylie, of Read Island, B. C., a prominent lumberman and pioneer of the country, was a visitor in Vancouver last month, his trip being a combination of business and pleasure. Mr. Wylie reports better times and increasing activity among the loggers up north.

Mr. R. H. Campbell, of the Department of Interior, Ottawa, has been promoted to the position of chief clerk and head of the timber and mines branch, which became vacant through the resignation of Mr. Ryley. Mr. Campbell is also secretary of the Canadian Forestry Association.

Mr. G. P. Wells, late manager of the W. C. Wells Company at Palliser, B. C., is mentioned as likely to be appointed permanent secretary and organizer of the Mountain Lumber Manufacturers' Association. He is certainly well qualified for the position, being a thorough lumberman.

The offices of the Arrowhead Lumber Company, Arrowhead, B. C., were the scene of a pleasant event recently, when Mr. Rend Gibbons, the general manager of the mill, was made the recipient of a set of solid silver knives, forks, spoons, etc., from the

employees of the company, as a mark of their esteem, it being the occasion of Mr. Gibbon's return from Calgary, where he was, on the 9th ultimo united in wedlock to Miss Mills, late of Chester, N. S.

Mr. John Grier, of the lumber firm of J. & B. Grier, Montreal, died at Ste. Anne de Bellevue on Saturday, September 30th, in his 76th year. He was born and educated in Ottawa (then By-Town.) At 20 years of age, he went into the timber and lumber business, and three years later was joined by his brother, Mr. Brockwill Grier, when the firm of J. & B. Grier was formed. Fifty-five years ago he married Miss Olive Dunning, who pre-deceased him thirteen years ago. Mr. Grier is survived by one son and three daughters.

Mr. and Mrs. Hiram Robinson, of Ottawa, celebrated their golden wedding on Wednesday, October 25th, the fiftieth anniversary of their marriage. Mr. Robinson, who is president of the Hawkesbury Lumber Company, has had a most successful business career, and although he has ever been an ardent worker, he has found ample time to devote himself to public matters. He was born in Hawkesbury, Ont., in 1831, and from 1847 was employed in the Gatineau lumbering district for Hamilton Bros. In 1850 he was given a position in the Ottawa office and in 1888 was made president of the Hawkesbury Lumber Company, which took over the business of Hamilton Bros. He is interested in the Upper Ottawa Improvement Company, the Ottawa & Hull Power Company and other enterprises, and is an active officer of the Canadian Forestry Association.

KENDALL'S PATENT ROTARY VALVE.

Mr. I. N. Kendall, of Ottawa, has patented a rotary valve for canter, kickers and log loaders, which is intended to take the place of the ordinary piston valve heretofore used for this purpose. The cut herewith shows the valve and the manner in which it is attached to the cylinder. It is claimed to be the simplest, most easily adjusted and most economical valve of any valve on the market to-day, and can be attached to any canter or kicker now in use.

Should the cylinder to which it is desired to attach these valves have but one feed pipe as many have with the old style piston valve, all that is necessary to do is to drill and tap two holes in cylinder for 1 in. pipe as shown at B in small cut, which shows a method of attaching valve to cylinder. In operation steam is admitted to cylinder through pipe A, causing piston to move to opposite end from which steam is admitted. When work has been done and it is desired to exhaust the steam and allow piston to return to original position, the part in valve which admits steam to pipe A is closed by operating handle H, and part in valve connecting pipe B with the pipe to open air is placed in position. When the descending piston has crossed the point where pipe B enters the cylinder it shuts off the steam from further escape through pipe B and confines

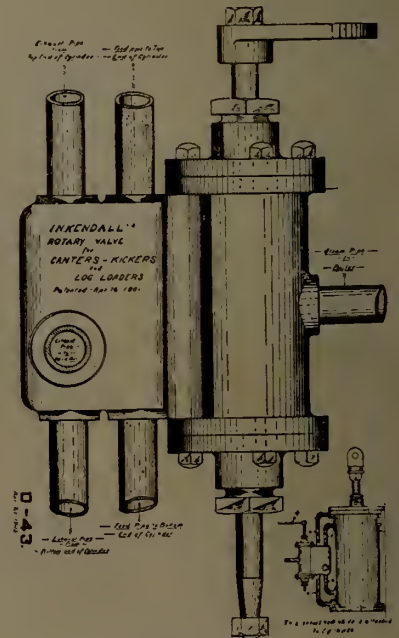

KENDALL'S PATENT ROTARY VALVE.

it to the space in the cylinder, between the bottom of the cylinder and the descending piston. As the steam there confined cannot escape through pipe A it follows that it must form a cushion for the descending piston and prevent it from coming in contact with the bottom of the cylinder with any considerable force. The valve being rotary and semi-circular is held up tightly to its seat by means of the steam pressure behind it, which is counter-balanced by means of springs which prevent the steam from pressing the valve too tightly to its seat. The use of two pipes to each end of cylinder from valve, one for steam and one for exhaust, was first used in connection with this valve and is Mr. Kendall's invention.

STATE MAP ON A PLANK.

Most easterners are more or less curious about the big trees of the western coast country, but unless they can take a trip to that section they must be content with pictures of the forest mammoths or "tall" stories told regarding them by persons who have visited the timber districts. Those who attend the Lewis and Clark Exposition at Portland, in the midst of the big tree country, find plenty of material there to satisfy their curiosity. While, as stated, Portland is in the land of the big tree, most of the mammoth trees in the immediate vicinity have been cut down, and it is necessary to go some little distance before finding a tree big enough to hollow out and use as a two-room house. But at the Exposition there is a hollow stump which is used as an office by Ezra Meeker, an old pioneer, who has a collection of early relics; and there is another stump section, hollowed out, which will accommodate about thirty people very comfortably.

In the Washington state building there is a map of the eastern section of that state, painted upon the surface of a plank cut from a Washington spruce tree. The tree was 12 feet 8 inches in diameter at the butt. The map is about 12 feet square, and is undoubtedly the largest map ever made on one plank.

TRADE NOTES.

The Capstan Mfg. Company, Toronto, have installed a new mincemeat machine with a capacity of a ton per hour it meets the demands of the fall trade.

The Canadian Fairbanks Company, Montreal, will shortly issue the first section of their new supply catalogue, which will be devoted to pipe and steam fitters' tools.

Henry Disston & Sons, saw manufacturers, are building a large brick factory on Lombard street, Toronto, from which the Canadian trade will be supplied.

Large sales of their new four inch steam setting mashine are being made by the William Hamilton Manufacturing Company. They have been installed by J. B. Smith & Sons, Toronto, Colonial Lumber Company, Pembroke, and others.

The Laurie Engine Company, Montreal, have supplied one of their standard Corliss engines for a new pulp mill now being built at Seven Islands, in the Gulf of St. Lawrence. They are also building a cross compound Corliss engine and a Simplex power pump for the Rolland Paper Company, of St. Jerome, Que.

The Canada Saw Company, Limited, of Ottawa, are

building a new factory in St. Henri, Que. It will be 100x145 feet, four stories, and equipped with all the latest machinery for the manufacture of band, circular, cross-cut and hand saws. The company have had a very successful season and report very bright prospects for next year.

Mr. Soy has succeeded Mr. Freeman as superintendent of the Grand River Lumber Company's mill at Hamilton Inlet, Labrador, in which Mr. Alfred Dickie, of lower Stewiacke, N. S., is largely interested.

The Hart Corumdam Wheel Company and the Canadian Corumdam Company have amalgamated, under the name of the Canadian Hart Corumdam Wheel Company, Limited. The capital stock of the new concern is \$75,000 and the head office will be at Hamilton. The provisional directors are G. F. Webb, C. S. Wilcox, S. E. Sherk and C. H. Warren.

Official announcement has been made that the Niles-Bement-Pond Manufacturing Company, of New York, have acquired a controlling interest in the business of Bertram & Sons, Dundas, Ont. The capital of the company has been increased from \$200,000 to \$400,000, the intention being to make extensive improvements, including the erection of new buildings.

PAT. OSCILLATING BOB SLED KNEE
 Handles 25 per cent. easier, and wears longer, and is lighter than all others.
THOMPSON MFG. CO., Ltd.,
 Grand Bay, N. B.

FOR SALE

In guaranteed good serviceable condition, Steam Engines, Boilers Pumps and attachments, Iron and Wood Working Tools. Less freight to Niagara Falls, N. Y., or equivalent. Catalogue mailed for asking.

PAYNE MACHINERY EXCHANGE CO.
 ELMIRA - - - - - NEW YORK

STEARNS BILLING VISIBLE TYPEWRITER

Manitord—Gauze Carbon Paper
 Royal Paragon Typewriter Ribbons
 Cantype Spring Frame Duplicators
 Stencil Paper and Inks

CANADIAN TYPEWRITER CO.,
 119 St. Francois Xavier St., Montreal
 68 Victoria St., Toronto

THE NEW
Dominion Saw Gummer
 Saw Gummer Cutters of all Descriptions
 MANUFACTURED BY
A. T. McLATCHIE, Car. inal, Ont.

WANTED

Saw mill men to send for 144 page catalogue of up-to-date line of saw mill, gang edger, lumber trimmer, planing mill and shingle mill machinery manufactured by
DELOACH MILL MFG. Co.,
 P.O. BOX 509, Atlantic, Ga.

A COMPLETE FACTORY FOR \$650

- 1 Concrete Stone Making Machine.
- 1 Concrete Brick Making Machine.
- 1 Power Concrete Mixer.
- 1 5 H. P. Gasoline Engine.
- 1 Window Cap and Sill Mould.
- 1 Set of Sidewalk Toois.

This is the most complete outfit made for the manufacture of concrete building material. Get ready for the spring trade. \$650 invested in this outfit will bring larger returns than \$3,000 in a Mercantile Business or \$6,000 invested in a farm. We shall be pleased to send you our catalogues and printed matter.

NORTHWESTERN STEEL AND IRON WORKS
 EAU CLAIRE - - - - - WISCONSIN

C. H. VOGEL
 A. M. Can. Soc. C.E.
 OTTAWA, CAN. ENGINEER
 Surveys, Plans, Specifications and Supervision
 - WATER POWER
 Paper, Pulp and Sulphite Fibre Mills

G. T. KNIGHT & SON
 Manufacturers of
Building Supplies
 we make a specialty of
 Doors and Sashes; Mouldings and all kinds of turned goods.
 Address, MEAFORD, ONT.

Please mention the CANADA LUMBERMAN when corresponding with advertisers.

"SANFORD" LOGGING TOOLS
 Have been for 50 years
"THE STANDARD" FOR LUMBERMEN

OUR MOTTO: Quality, not Quantity. The Best is the Cheapest.



We make a Specialty of
LABOR SAVING TOOLS FOR LUMBERMEN

"SANFORD TOOLS" are guaranteed to please

Send for our "Illustrated Catalogue" and let us quote you—We can interest you

A. SANFORD LOGGING TOOL CO.,
 OSHKOSH, WISCONSIN, U.S.A.

WOODWORKERS SAY
 "The convenience to the Sawyer and the saving in lumber make the **STANDARD AUTOMATIC SAW GAUGE** an article of much merit."
 WRITE TO
SPECIALTY MFG. CO.
 DETROIT Mich.

SANFORD LOGGING TOOLS.

Loggers and mill men will be interested in the advertisement in this issue of the A. Sanford Logging Tool Company, Oshkosh, Wis., who manufacture the largest and most complete line of lumbermen's tools and specialties in the United States. For fifty years this firm has made a specialty of supplying the lumbermen with the best tools that good material and experienced mechanics could produce—their aim has always been and still is, to make "better tools" than any other manufacturer.

The Sanford Logging Tool Company have just erect-

ed a mammoth fire-proof plant consisting of three large buildings constructed of stone, brick and steel, and equipped with modern and up-to-date machinery, giving them the largest and most up-to-date plant of the kind in the world. They issue an illustrated catalogue, which is free for the asking, showing their complete line, consisting of cant hooks, peavies, pike poles, timber carriers, skidding tongs, chain hooks, cold shuts, saw and axe wedges, logging dogs, log stamps, wagon woods and irons, car movers, lumber rollers, timber dollies, lumber carts and other labor saving tools for lumbermen too numerous to enumerate here.

A RUSSIAN MINE OF OAK.

A Russian timber dealer is said to have discovered a valuable mine of oak in a river of South Russia, it being in layers 3 or 4 feet deep, scattered over 150 square miles, and its most striking feature is its variety of colors, supposed to be due to the variegated soil of the river bottom. No fewer than 12 shades of pink, blue, yellow and brown have been noted, each log having its own uniform shade. The logs taken out have ranged from 40 to 200 feet in length and from 15 to 20 inches in diameter, and it is estimated that more than 150,000, averaging 70 feet, remain.

OSBORNE & CLARK

WHOLESALE

HARDWOOD LUMBER . .

MAPLE AND OAK FLOORING

300 Lumber Exchange, MINNEAPOLIS, MINN.



LET THE BOY WORK IT

Any boy can point 5,000 or more pickets a day with a *Portland Picket Pointer*. Easy in manipulation; speedy in action; perfect in results. More than doubles profits on picket making.

Booklet Free

TRY THIS METER

The Famous Portland Lineal Meter

A little machine, but a big saver of stock, time and cash, for you when sticking moulding, etc.

Write For Circulars



ADDE & CO.,

109 Kennebec St. - PORTLAND, ME.



RESAWING MACHINE

This machine has been designed to meet the demand of mill owners for a powerful machine. In this machine the frame is cast in one piece. All the legs are of cast iron and those under the saw table are cast in one piece with it.

The rolls are of large size and driven by still larger gears cut from the solid. This gives a powerful drive. The machine, as can be seen from the engraving, is provided with a steam press and there is a very convenient gauging mechanism for the stationary roll, not shown in the cut.

The most up to date resawing machine made.

THE SAVOIE-GUAY COMPANY

Makers of Saw Mill Machinery,

PLESSISVILLE STATION, P. Q.

USE

"MIDLAND" BABBITT METAL

IN YOUR BEARINGS

None Better

GEORGIAN BAY ENGINEERING WORKS
MIDLAND, ONT.

PAROID ROOFING

"The Roofing of Quality"

You can save money and guarantee permanent results if you use Paroid on all of your work. The U.S. Government, the largest railroads and manufacturers all over the United States and Canada have used Paroid for many years.

Write us for samples, prices and dealer's proposition.

F. W. BIRD & SON, MAKERS,

Established in U. S. A. in 1817.

Canadian Factory & Office:

HAMILTON, ONT.

THE RETAILERS' PROFIT.

In reply to questions on the subject, a number of retailers in the Northwest have expressed the opinion that a gross profit of twenty-five per cent. should be asked on the upper grades of lumber carried by them, and that a gross profit of fifty per cent. on mouldings is none too much. Both of the stocks must be handled with special care. The finishing grades of white pine must be piled with a great deal of care and protected from the weather. If it becomes discolored with age or is damaged in appearance in any way, the customer will not take it at the high price that must be asked to

insure any profit at all. In the case of mouldings, they must be kept in a rack from which rain and dirt must be excluded. They become almost worthless to the retailer if they lose the brightness of new lumber. For these reasons the above profits are no more than the retailer ought to get to insure him against loss on the portion that becomes unsaleable after it has been carried for some time.

Some very fine specimens of larch from the East Kootenay Lumber Company's mills at Cranbrook were recently examined by experts at Winnipeg. Architects and builders say it is undoubtedly a splendid wood for interior finish.

SETTLERS LOW RATE WEST.

The Chicago and North Western Railway will sell low one way second class settlers tickets, daily from Sep. 15th to Oct. 31st, 1905, to points in Utah, Montana, Nevada, Idaho, Oregon, Washington, California and British Columbia. Rate from Toronto to Vancouver, Victoria, New Westminster, B. C., Seattle, Wash., or Portland, Ore., \$42.25; to San Francisco or Los Angeles, Cal., \$44.00. Correspondingly low rates. Best of Service. For full particulars and folders write to B. H. Bennett, General Agent, 2 East King St., Toronto, Ont.

P. PAYETTE & CO.

Manufacturers of Saw Mill and Engine Machinery and all kinds of Marine Machinery.

PENETANGHISHENE, ONT

TRANSMISSION ROPE

We are the largest Manufacturers of **TRANSMISSION ROPE** in Canada. Our mills are equipped with special machinery for manufacturing extra long lengths. We import the most select Brands of Manila Fibre, and are therefore in a position to supply a **FIRST CLASS ROPE**.

Rope Transmission has proved to be the most satisfactory and economical drive.

If you contemplate buying, we would be pleased to have our expert call upon you.

CONSUMERS CORDAGE CO., LIMITED
Montreal and Halifax

The following items appear on our Stock List and are to be cleared out this month. It is all new machinery and will be offered at Figures which represent actual Cost to us.

SAW MILLS

- 535 1-No. 1 Lane Mill R. H. Wood Frame, 16 ft. Carriage, Rope Feed, New.
- 536 1-No. 0 Lane Mill R. H. Wood Frame, 24 ft. Carriage, Rack and Pinion Feed, New.
- 537 1-No. 0 Lane Mill R. H. Wood Frame, 25 ft. Carriage, Rack and Pinion Feed, New.
- 538 1-50 in. Circular Rip Saw, Shurley-Dietrich, New.

SAW MILL EQUIPMENT

- 539 1-2 Saw Trimmer, New.
- 540 1-Lockport Shingle and Heading Machine, New.
- 541 1-Double Edger, 3 Saw complete with End Tables, New.

The Manitoba Iron Works Co.

LIMITED

Logan, Henry, Brant and Dorothy Streets,
WINNIPEG, MAN.

THE LUMBER MUTUAL FIRE INSURANCE COMPANY

BOSTON, MASS.

STRENGTH

NET ASSETS, NOVEMBER 30, 1905

All Liabilities Deducted—Sec. 1—Chap. 188—Mass. Laws.

\$714,868.12

ECONOMY

DIVIDENDS TO POLICY HOLDERS

33 $\frac{1}{3}$ %

MAIL EXPIRING POLICIES WITH YOUR ORDER.

THE DYMENT FOUNDRY COMPANY

BARRIE, ONTARIO

Manufacturers of

Engines, Boilers Steam Feeds . . .

AND A COMPLETE LINE OF

Saw, Shingle and Lath Mill Machinery

Can ship mills in a week's notice. Write us for prices and Catalogue.

DRAKE'S IMPROVED

"Swing" Shingle and Heading Machine

The old time Swing Shingle Machine has been before the public for many years. It had many good points which are so well known that it is unnecessary to mention them here.

The Machine shown in the accompanying cut is an improvement over any other Swing Shingle Machine in the market. Its simplicity renders it easily managed by anyone capable of keeping a saw in order. It is thoroughly adapted for sawing either shingles or heading without removal or addition of any parts. It is easily adjusted for any desired thickness of either shingles or heading, and any desired taper for shingles is readily obtained by screws placed for the purpose. The set works are tilted for butts and points automatically, or any desired number of butts or points may be cut from either top or bottom of block.

Machines are furnished with or without jointer.

We are quoting special low down prices for quick delivery. Let us quote you and send for Catalogue.

F. J. DRAKE,

BELLEVILLE,

ONTARIO

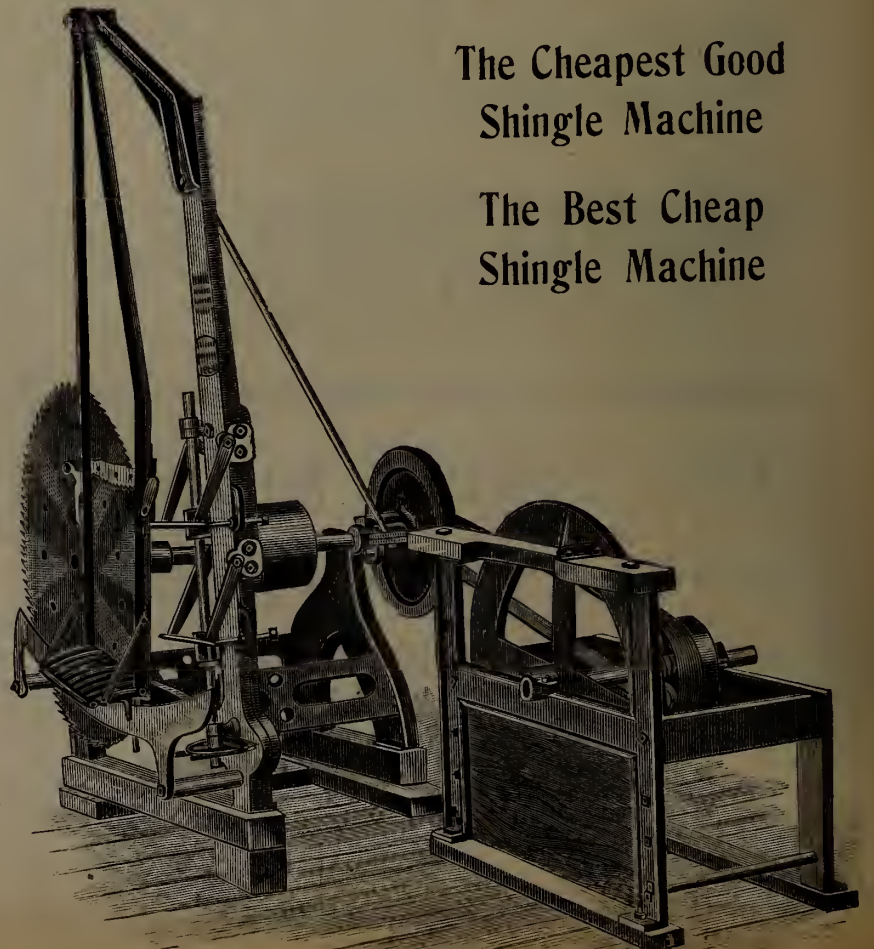

The Cheapest Good
Shingle Machine

The Best Cheap
Shingle Machine



SCRIBNER'S LUMBER
AND LOG BOOK
Price 35 Cents.
The CANADA LUMBERMAN
TORONTO

Dundas Lumberman



A New Axe tempered by a new process which enables us to submit to any lumberman three or more samples of Axes, all different degrees of hardness, and on a selection being made we will guarantee to furnish any number all exactly the same temper as sample chosen.

THE DUNDAS AXE WORKS
Dundas, Ont.

LUMBERMEN

—SHOULD SEE OUR—

PATENT SEAMLESS HEEL LARRIGANS

No chance to rip where it generally does rip in the ordinary make. Also our

PATENT LEGGING

The only legging where the bell front is held down close to the foot so that it can't turn up

—BOTH MANUFACTURED BY—

THE R. M. BEAL LEATHER CO. LIMITED.

Write Us

LINDSAY, ONT.

NEW SEASON'S CURING

LONG CLEAR BACON

SHORT CUT PORK - SAUSAGE, MEATS, &c.

High Grade Quality
Write us for Quotations

THE PARK BLACKWELL CO., LTD.

PORK AND BEEF PACKERS
TORONTO

Special to Lumbermen, Miners and Railway Contractors



We are Manufacturers of:—Mince Meat, Baking Powder, Coffee, Spices, Flavoring Extracts, Mustards, Tomato Catsup, Worcestershire Sauce, Jams, etc., and all kinds of Grocers' Sundries for Camp Use. Also Sauer Kraut, Pickles and Sausage Meat.

Mince Meat put up in 75 Pound Tubs. 1/2 Barrels about 300 Pounds.
Barrels about 600 Pounds.
Sauer Kraut and Pickles in Barrels. Sausage Meat in 50 Pound Tins.
Sauce and Catsup in 5 Gallon Pails.

ALL GOODS GUARANTEED
... Special Attention Given to Mail Orders ...



The Capstan Manufacturing Co., TORONTO, ONT., CAN.

The Gravenhurst

"BOSS" SHINGLE MACHINE

The Best Machine on the Market

The Simplest in Construction of any Machine Built

We build Shingle Machines both Horizontal and Vertical

We also build All Kinds of Saw Mill and Shingle Mill Machinery.

Send Us Your Orders, Large or Small—We Can Fill Them

Write for Catalogue

B. R. MOWRY & SONS
GRAVENHURST, ONT.

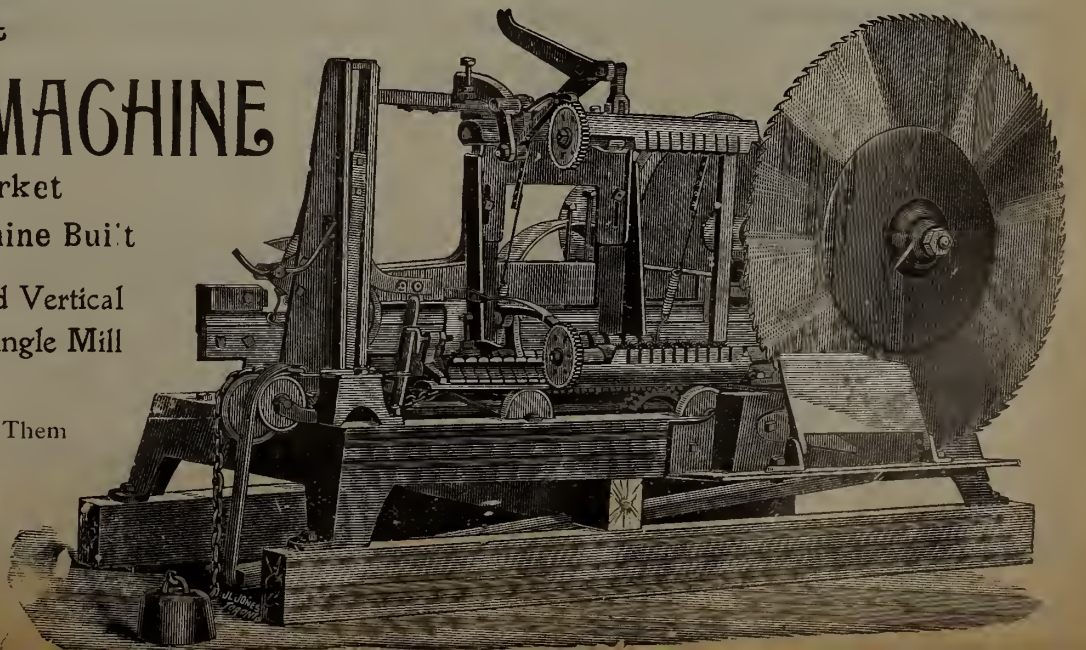

P. H. WRIGHT
 43 Bank Street, OTTAWA
Lumbermen's Agent
 All kinds of Mill and Bush
 help secured on short notice
 Telephone 2586

OILS
 Manufacturers High-grade Cylinder, Ma-
 chine and Sawmill Oils.
Calypsol Grease
 for Sawmill Purposes a Specialty.
 Our products are made from finest Penn-
 sylvania stocks.
 We solicit your correspondence.
 St. John St., **Commercial**
 MONTREAL. **Oil Co.,**
 Offices and Works :
 Manchester, Eng. Hamilton, Ont.
 Hamburg, Germany.
 Newark, N. J.
 Chicago, Ill.

THE E. L. PURVIS CO.,
 18 COLBORNE ST., TORONTO, ONT.

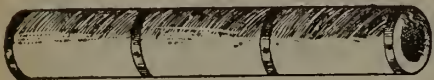

PIPE AND BOILER COVERINGS

Asbestos Mineral Wool
 and all kinds of Fireproofing

Material. Agents for

FA MOUS MICA COVERINGS

H. J. FRIEL
 EMPLOYMENT AND LUMBERMEN'S AGENT
 Bushmen supplied on short notice, also
 mill hands. Hotel help of all kinds procured.
Office : 75 BANK STREET
 Phone 721 - - - - - OTTAWA



Sole Canadian Agents - Prices Reduced
WATEROUS, BRANTFORD, CANADA

MAPLE LEAF
STITCHED COTTON DUCK
BELTING
DOMINION BELTING CO. LTD.
HAMILTON CANADA



Ever
 seen
 one
 of
 these
 powerful

MC GIFFERT LOG LOADERS

at work, loading or skidding logs, or maybe, switching
 its own empties? If you haven't you can't fully appre-
 ciate the immense amount of heavy work it can do—
 and at such a saving. It is really wonderful.

Send for catalogue, also booklet of facsimile testimonial
 letters.

Clyde Iron Works
 Duluth, Minnesota, U.S.A.

AT A BARGAIN

- ¶ One 350 Horse Power 16 in. and 28 in. x 36 in. Cross Compound Engine, fitted with Balanced Valves—a strong, durable Engine exactly suited to heavy Saw Mill service.
- ¶ We can finish it up in one week and will sell at a bargain.
- ¶ Full particulars on request.

The JENCKES MACHINE CO., Ltd.
 SHERBROOKE, QUE.

ATKINS ALWAYS AHEAD!

DEFINITE IDEAS



QUALITY IS THE THING!

are suggested to mill men by the words Atkins and Silver Steel. You know that Atkins stands for honesty and thoroughness in workmanship and the most careful supervision of every detail of saw making. And Silver Steel stands for the most perfect material that ever went into a saw.

"The Proof of the Pudding is in the Eating"—An impartial trial will establish the fact that our Saws will cut 25% more lumber at less expense of the and labor than any others.

Write us for our Sawyers Hand Book.
 General Sales Agents for Covels Filing Room Machinery.

E. C. ATKINS & CO., Inc.,
 Leading Manufacturers of Circular, Band, Cross-Cut, Hand and Wood Saws, Etc.

Factories and Home Office,
 Indianapolis, Ind. U.S.A.

Canadian Branch,
 56 King St East, Toronto, Ont.

WARNOCK TOOLS

Best in the World



If Strength, Durability, Correct Construction and Lightness are an object, we have the article you are looking for.

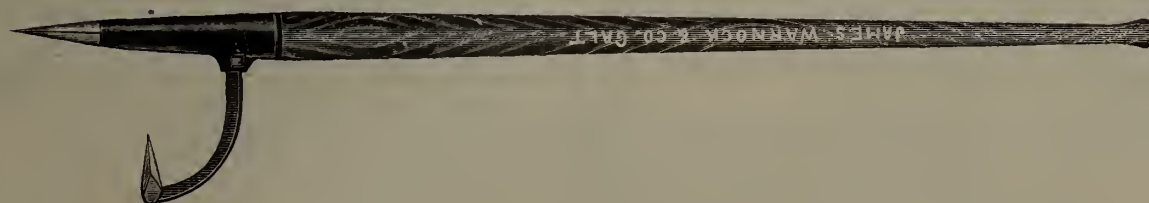
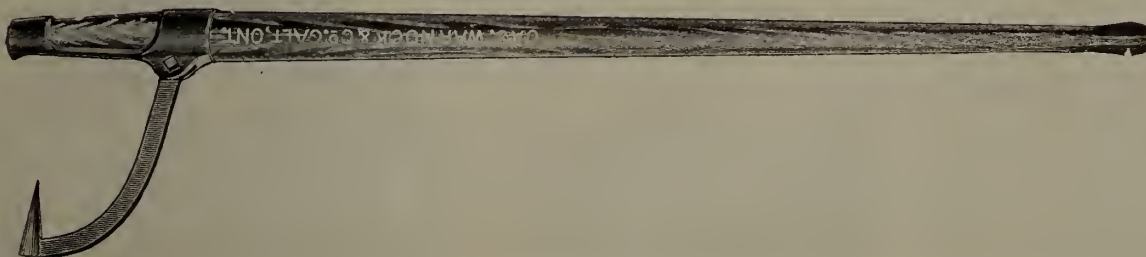

THE JAMES WARNOCK CO., LIMITED
GALT, ONT.

Cross-Grained and Knotty Lumber
IS WELL FINISHED WITH

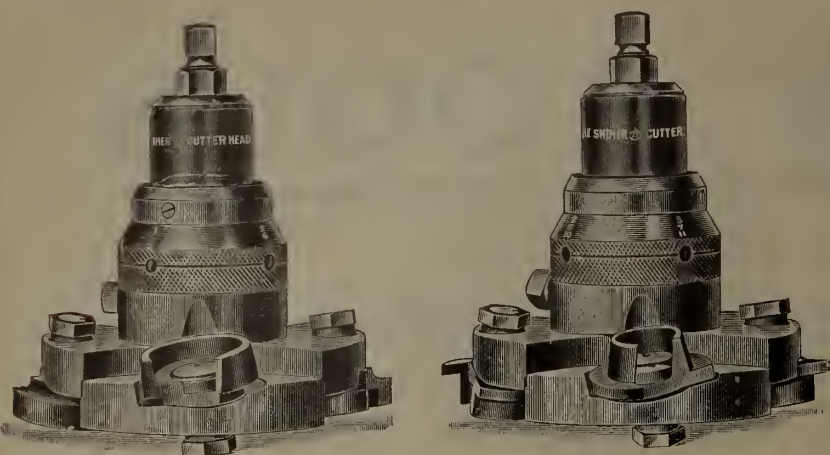

The Shimer Gutter Head

It reduces the number of culls as no other Head can.
The Cutters work alternately with side clearance; ply their way through the worst lumber that you may find for high grade finish.
The bit seats and their bit and bolt combinations supply the make-ready for every emergency.
For tight and loose fitting of tongue and groove joint, a single turn of the expansion ring will suffice, with automatic stop and lock.

NOTHING { **COMPLICATED TO GET OUT OF ORDER**

The Shimer Cutter Head is made to fit any make of matcher or moulder. You take the measurements—we do the rest, and guarantee to fit your spindles. Address

SAMUEL J. SHIMER AND SONS
Milton, Pennsylvania

RUBBER BELTING

For
Transmitting
Elevating
and
Conveying



Rubber
Hose
for
Water
Steam
Air
Suction
Fire
Protection

THE GUTTA PERCHA & RUBBER MFG. CO.
OF TORONTO, LIMITED.

HEAD OFFICES: 47 YONGE STREET, TORONTO, CAN.
Branches: Montreal, Winnipeg, Vancouver.

RODGERS IRON MFG. CO.

MUSKEGON, MICH.

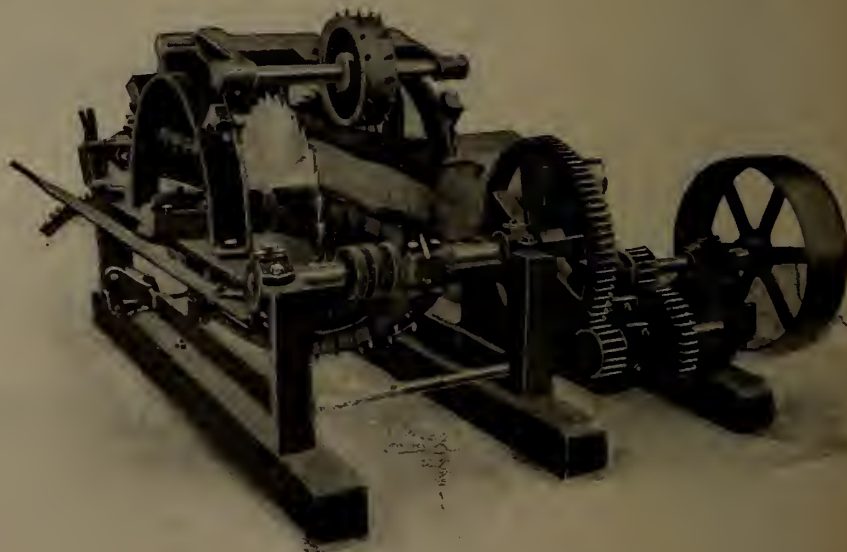

ADJUSTABLE LOG SIDER OR TIE MACHINE.

A Money Maker Write to Us
We will Tell You All About It

Berkley, Norfolk, Va., Sept. 8th, 1904.

Rodgers Iron Mfg. Co.,
Muskegon Mich.

Gentlemen—In regard to the adjustable log siding machine which we purchased of you, it is far beyond our expectations. We are now running 3" saws and have no trouble in slabbing our logs from 6" to 20" in diameter. We consider the machine one of the best of the kind on the market; in fact we know of no machine which will equal the one which we have. It is giving entire satisfaction, and we would be glad to show it to any parties who may be interested if they will call at our mill.
Yours very truly,

Fleming, Centre Co., Pa., March 11, 1905.

Rodgers Iron Mfg. Co.,
Muskegon, Mich.

Gentlemen -
Replying to yours of recent date and referring to your Tie machine, we are cutting from 1,000 to 1,200 mine ties, 5 feet long, per day, with a 25 horse power engine.
Respectfully

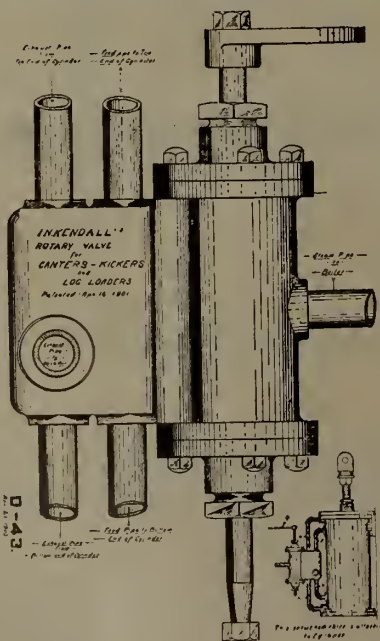

The Kendall Rotary Valve for Canters

KICKERS, LOG LOADERS AND JUMP-UP SAWS

Can be attached to any Canter or Kicker now in use. It won't leak steam but it will cushion the piston at either end of the cylinder without fail. Many of these valves have been in use for the past four years without having any repairs or attention paid to them.
They are cheap in price too.

I. N. KENDALL, 203 Bridge St.
OTTAWA

SHERMAN'S FLOORING MACHINES

PATENTED

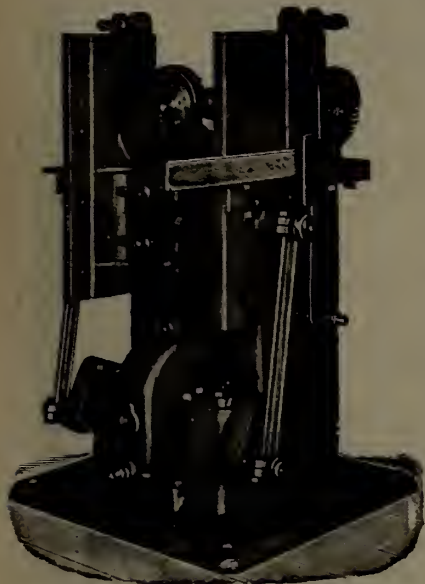

Above cut shows our End Matcher, the best machine in the market for end matching flooring strips. They do rapid and accurate work, and are durable—therefore used by leading flooring manufacturers. Make your flooring profitable by end matching it.

We Make the

SHERMAN SIDE BORING MACHINES

and the

SHERMAN FACE BORING MACHINES

To bore flooring while it is being run on the flooring machine. Write for circular and list of users.

W. S. SHERMAN CO.

1150 Holton St., Milwaukee, Wis.

Reliable Veterinary Remedies

No logging outfit is complete without a supply of reliable veterinary remedies. Getting the wrong kind means the loss of the use of your horses when time is valuable.

Johnson's Veterinary Remedies are guaranteed never to fail when used as directed. You get your money back if they ever do.

They are

Johnson's Horse Liniment No. 1.

A penetrating Alcoholic Liniment. Put up in one gallon jugs, with full directions, per imperial gal. \$4.50

Johnson's Horse Liniment No. 2.

A combination of the best oils used as liniments, imp gallon . \$3.00

Johnson's Horse Colic Remedy.

A sure and speedy cure for colic Imperial gallon \$5.00

Johnson's Veterinary Healing Ointment.

Positively the best all-round healing ointment made. In use by the largest owners of horse flesh in Canada.

Put up in 2 lb tins, each . . . \$2.00

or in 1/4 lb tins, per dozen . . \$3.00

Johnson's Condition Powders. (Concentrated).

Put up in bulk, per lb 3c.

These goods being put up in bulk are more economical than others, as cost of bottling, etc., is saved.

CAMP REMEDIES.

In addition to our Veterinary Remedies we make a line of medicines for lumbermen, including a strong, penetrating liniment, healing ointment, cholera cure, liver pills, cough syrup, in fact anything in the form of Camp Drug Supplies. We know that there are no better remedies made than those we offer. There may be others nearly as good, but they lack our guarantee. Satisfaction or money back. A trade discount of 10% allowed off all orders amounting to \$100.

Send postal for printed matter.

A. H. JOHNSON

Wholesale Druggist

Collingwood, Ont.

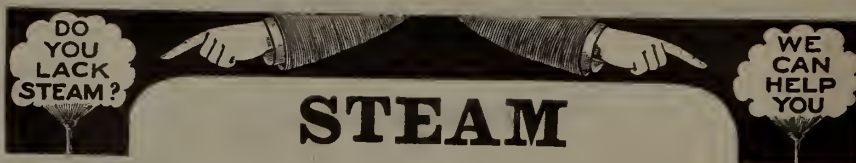

STEAM

Are your present boilers capable of generating steam PART of the time but not ALL of the time?

Would you like to obtain EVERY OUNCE of steam your boilers are capable of making EVERY MOMENT in the day?

Would you like to do it with sawdust alone?

THE

GORDON HOLLOW BLAST GRATE

will enable you to do it.

Sold on approval, and returnable at our expense if unsatisfactory.

The GORDON HOLLOW BLAST GRATE CO.



The Largest Manufacturer of Blast Grates, Edgers and Trimmers in the World

GREENVILLE, MICHIGAN.

A FINE STEAM PLANT

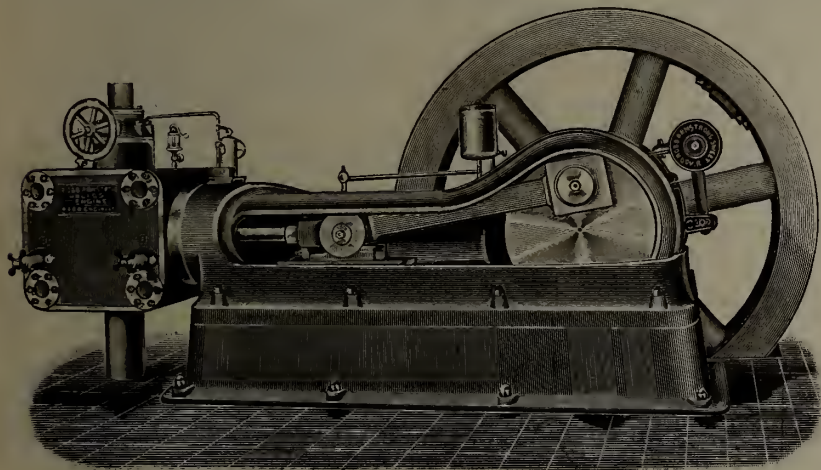

"I will say without qualification that it is as fine a boiler and engine plant as I have ever had the pleasure of seeing for its size. The engine was working without heating and absolutely without any noise. I wish to congratulate you on your success in building this class of engine and hope that we may have pleasure in dealing with you again."

The above refers to a 350 horse power Robb-Armstrong Corliss engine and two 175 horse power Robb-Mumford boilers installed by us.

ROBB ENGINEERING CO., Ltd.
AMHERST, N.S.

AGENTS: WILLIAM McKAY, 320 Ossington Avenue, Toronto. WATSON JACK & COMPANY, Bell Telephone Bldg., Montreal. J. F. PORTER, 353 Carlton St., Winnipeg.

Gonnell & Dengler Machine Co.

ROCHESTER, N. Y.

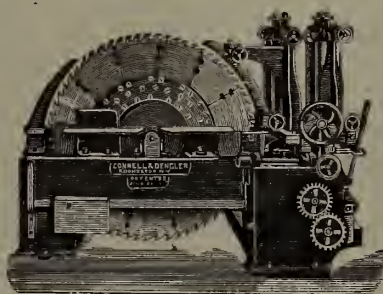

44 inch Circular Re-Saw.

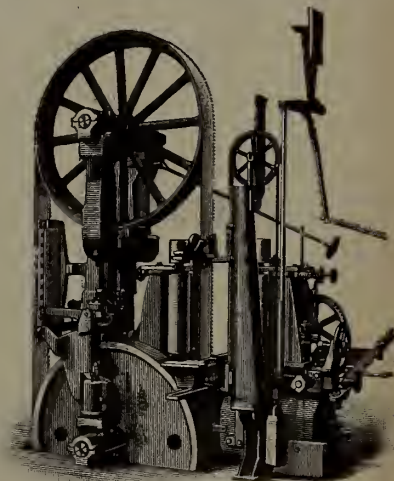

6c 11c. Band Re-Saw

Manufacturers of . . .

Box Makers' and Planing Mill Machinery



Heavy 26 inch Divided Roll Planer and Matcher with 8 Feed Roll.

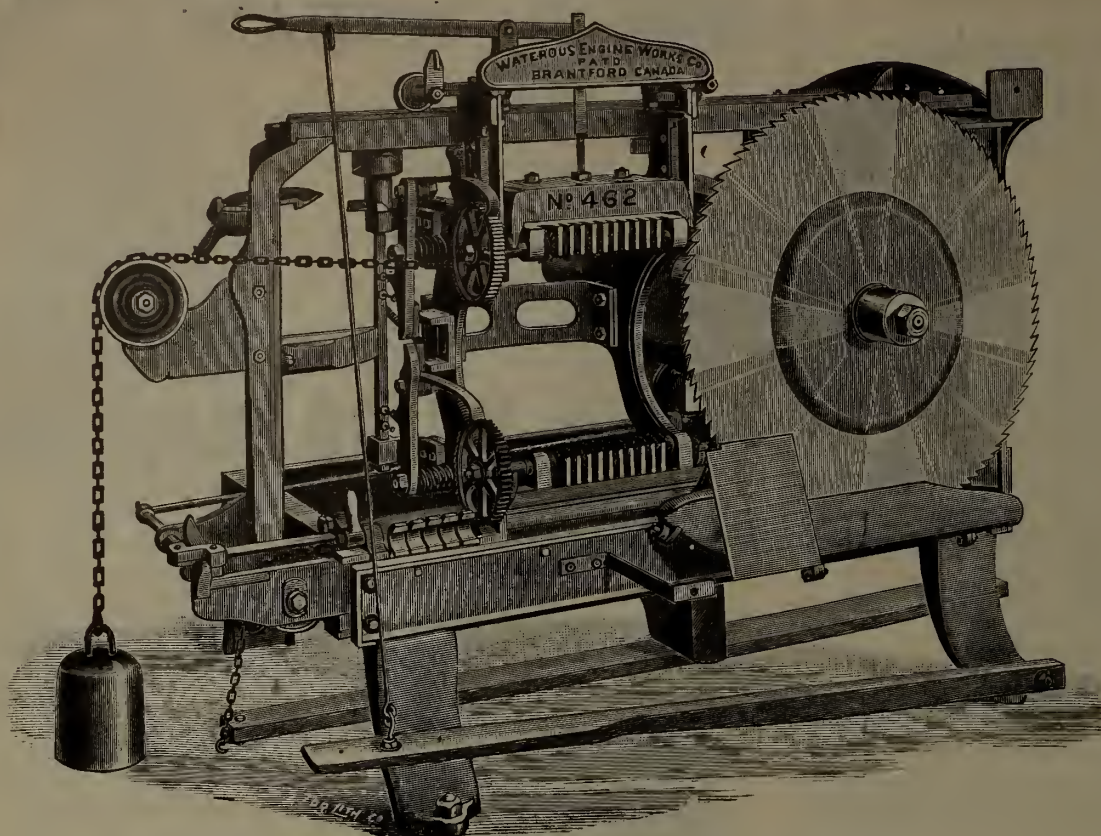

WATEROUS SELF-FEED SHINGLE MACHINE
(BUILT IN FIVE SIZES)

Leaves but $\frac{7}{8}$ in waste on spalt when desired.

This machine is the result of many years experience in this line.

THE IMPROVED "DIXIE"
HAND FEED SHINGLE MACHINE

Patented in United States and Canada

ROLLER BEARING CARRIAGE
AUTOMATIC TILT
QUICK DROP TILT



(BUILT IN FOUR SIZES)

Send for Circular giving full particulars of these machines, and prices. . . .

WATEROUS ENGINE WORKS CO.
BRANTFORD, CAN.

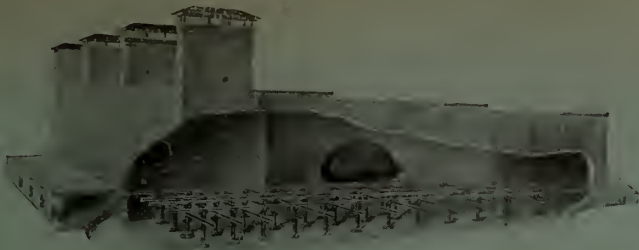

THE STANDARD DRY KILN

is sold on its proven merits. Briefly, these are:
 (1) Successful application of the one correct drying principle; (2) Simplicity and safety of its system, and ease of operation; (3) Modern brick and steel construction of the kiln building.

Satisfactory drying of all kinds of woods not only is claimed for "The Standard" Moist Air System—but is demonstrated and guaranteed to every purchaser.

Ask us to Send You Catalogue "D" and Other Interesting Printed Matter

The Standard Dry Kiln Co.
 Indianapolis, Indiana

The Standard Dry Kiln's efficiency has recently been increased and the cost and labor of installation decreased, by important and exclusive improvements in its heating apparatus.



Experimenting with Dry Kilns is an Expensive Luxury

Why keep on using a Kiln that has to be regulated with dampers, chimneys and complicated fans. Put in a Morton Automatic Moist Air Kiln and your Dry Kiln troubles will be ended. We do not sell a man a Dry Kiln to dry Mahogany and then tell him it will dry Basswood staves. Our thirty years experience in the Dry Kiln business yours for the asking.

Write to-day for Illustrated Catalogue "C"

The A. H. Andrews Co.

174-176 Wabash Avenue - - - CHICAGO, U.S.A.

Eby Machinery Co., Western Agents, 17-19 Main St., San Francisco, Cal.



PLANING MILL EXHAUSTERS

Piping—Furnace Feeders

Cyclone Dust Collectors

Systems Installed Complete

— ALSO —

Natural Draft and Blower Dry Kiln Apparatus

Trucks, Cars, Etc.

Hot Blast Heating Systems

— Write for Catalogues —

SHELDON & SHELDON Engineers and Manufacturers
 GALT ONTARIO



FOR DRY KILNS

that will season lumber of all kinds and under all conditions, whether partially air-seasoned or green from the log, in shortest time and at least cost, entirely free from checking, warping or case hardening,

Write to—

McEACHREN HEATING & VENTILATING COMPANY, GALT, CANADA

HUTHER BROS. PATENT GROOVER OR DADO HEAD
For cutting any width groove from 1/4-inch to 2 inches or over

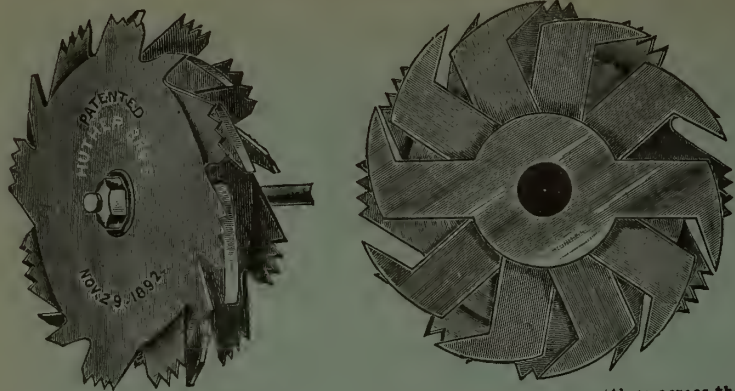

Can be used on any Circular Saw Mandrel. Will cut a perfect groove with or across the grain. This is the only Dado Head on the market that gives entire satisfaction on all classes of work. No screw adjustment. For different width grooves, simply remove or add inside cutters. Sold by builders and dealers of woodworking machinery in all parts of the United States. Will send on approval, in competition with any other make on the market; if not the best return at our expense. **HUTHER BROS.**, Platt Street, ROCHESTER, N.Y., manufacturers of Circular Saws, Morgan Pattern Lock-Corner Box Cutters, Concave Saws, etc.

LUMBERMEN'S LOG STAMPS
STEEL & RUBBER STAMPS, BRASS STENCILS, ETC.
THE SUPERIOR MFG. CO.
COR. BAY & ADELAIDE STS., TORONTO, CAN.
Write for Catalogue.

JNO. S. FIELDING, C. E.
WATER POWERS AND DAMS
Room 2, 15 Toronto Street - TORONTO

WIRE ROPE



All Kinds and Sizes and for All Purposes.

Standard and Lang's Patent Lay.

Prices Right. Prompt Shipments.

PROMPT SHIPMENTS

PRICES RIGHT Rope Fittings Rope Grease

THE B. GREENING WIRE COMPANY, LIMITED

HAMILTON, ONT.

MONTREAL, QUE

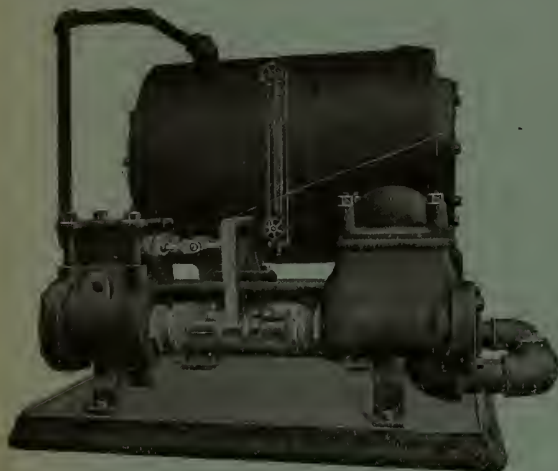

AUTOMATIC FEED PUMP AND RECEIVER
STEAM and POWER PUMPS
ENGINES BOILERS
THE SMART TURNER MACHINE COMPANY Limited.
Hamilton - Ontario

Uncle Sam would not allow his battleships to be babbitted with inferior babbitt metal. New Battleship "Nebraska" is lined with Syracuse Babbitt. Always specify best. It is cheapest in the long run.

SYRACUSE SMELTING WORKS

MONTREAL NEW YORK SEATTLE

CRESCENT MACHINERY

Quality is all right. So's the price.

Band Saws
Jointers
Saw Tables

Very low price on **BAND SAW BLADES**
Catalogue tells the rest.

H. W. PETRIE
Dept. C. M.
TORONTO, ONT.

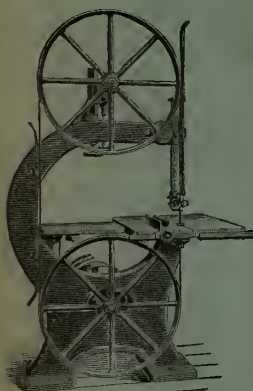

THE LEATHER BELT THAT'S KNOWN
OUR "EXTRA"



MONTREAL
WINNIPEG

TORONTO
VANCOUVER

PINK LUMBERING TOOLS

The Standard Tools

In Every Province of the Dominion, * * * * *
* * * * * New Zealand, Australia, Etc.



Pink Round Bill Peavey, Handles in Split Maple

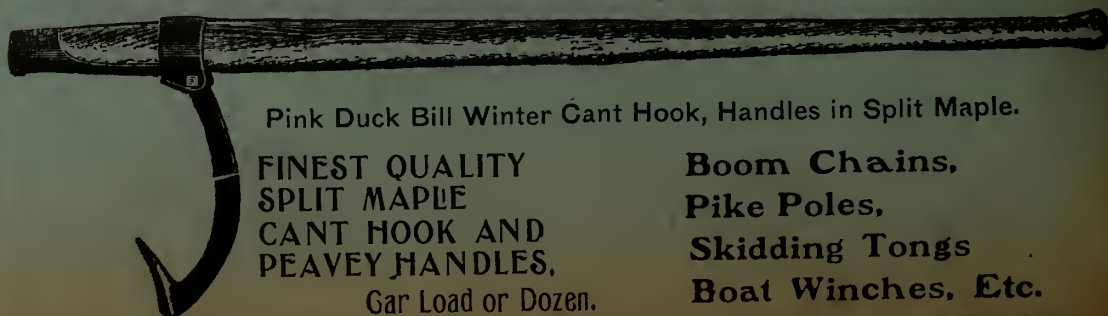

Pink Duck Bill Winter Cant Hook, Handles in Split Maple.

FINEST QUALITY SPLIT MAPLE CANT HOOK AND PEAVEY HANDLES.

Gar Load or Dozen.

Boom Chains, Pike Poles, Skidding Tongs, Boat Winches, Etc.

Sold Throughout the Dominion by all Wholesale and Retail Hardware Merchants.

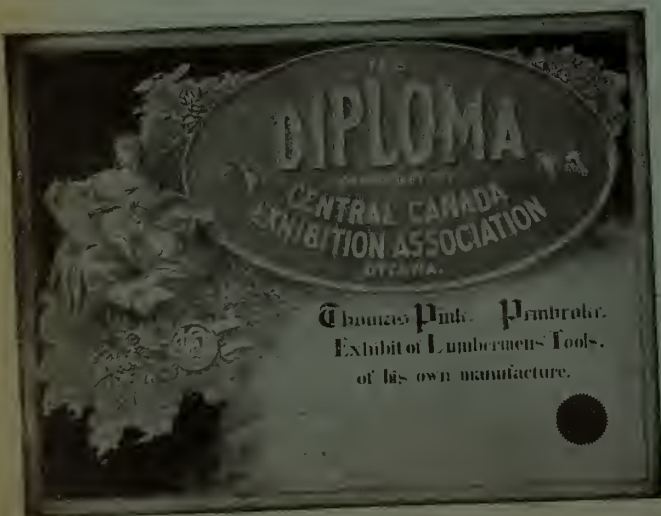

Thomas Pink, Pembroke, Exhibit of Lumbermen's Tools, of his own manufacture.

THOMAS PINK
Pembroke, Ont.

Send for Catalogue and Price List.

THE CANADA LUMBERMAN AND WOOD-WORKER

REACHES REGULARLY MANUFACTURERS, BUYERS AND SELLERS OF TIMBER PRODUCTS IN EVERY PART OF CANADA AND LEADING IMPORTERS ABROAD

VOLUME XXV. }
NUMBER 12. }

TORONTO, MONTREAL — DECEMBER, 1905 — WINNIPEG, VANCOUVER

{ TERMS, \$1.00 PER YEAR
Single Copies, 10 Cents. }

SNOW PLOWS

Logging Sleighs
Heavy Waggon

THE WILKINSON PLOUGH COMPANY, LIMITED
TORONTO, CANADA



LEATHER BELTING

It isn't the price, it's what you get for the price, that counts.

J. L. GOODHUE & CO.,
DANVILLE, QUEBEC.

D. K. McLaren
GENUINE

Oak Belting
MILL SUPPLIES

751 Craig St., Montreal
196 King Street West, Toronto
169 Prince William St., St. John, N. B.

WOODS LIMITED

Wholesale Manufacturers of . .

LUMBERMEN'S AND CONTRACTORS' SUPPLIES

INCLUDING

Tents, Flags, Awnings, Tarpaulins, Clothing, Overalls, Shirts, Mitts, Underwear, Blankets, Axes, Moccasins, Woods Celebrated Eider Down Sleeping Bags

WOODS BUILDING - OTTAWA, CAN.

SEND FOR H. W. PETRIE'S
MONTHLY STOCK LIST
NEW & 2ND MACHINERY
TORONTO, CANADA

DICK'S BELTINGS



Never is affected by wetness, and does not stretch

Excels in Transmission Power

Always Uniform.

LARGE STOCK ON HAND

WRITE TO SOLE AGENTS:

J. S. YOUNG, 14 Hospital Street MONTREAL

ALLIGATOR ROPES

We Carry in Stock a Large Assortment of WIRE ROPE and Fittings and Ship Promptly.

W. H. C. MUSSEN & CO.
MONTREAL, QUE.

The E. R. BURNS SAW CO.
TORONTO, ONT.

MANUFACTURERS OF HIGH-GRADE

CIRCULAR AND LONG SAWS

UNEXCELLED

SHINGLE SAWS

OUR INSERTED TOOTH SAWS POSITIVELY THE BEST



The Wm. Hamilton Mfg. Co. Limited

Builders of a Complete Line of

MODERN SAW MILL MACHINERY

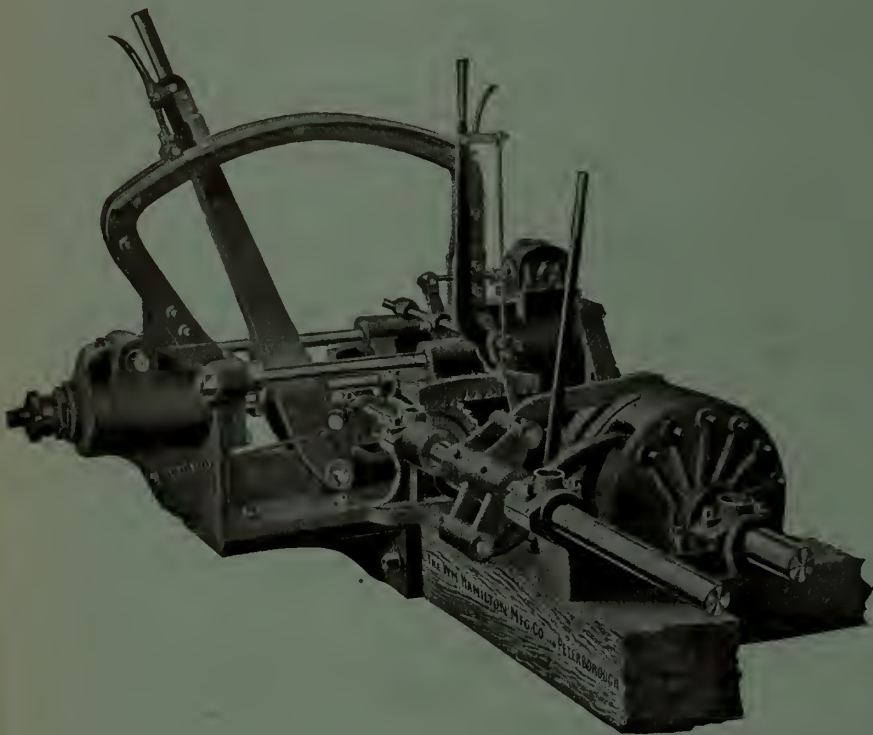

IMPROVED STEAM SETTING MACHINE

With Enclosed Dirt-Proof Ratchet Set Works.

This machine has all the advantages of steam setting machines, and in addition is larger and more powerful than others now on the market. It will set up to four inches with one throw of the lever, and will handle easily the largest log that can be cut on rack and pinion head blocks.

It is an ideal set works for a mill where quick and true work is an object, and it is giving satisfaction in more than a hundred mills.

A post card will bring our book, "Setting Machines for Sawmills", showing numerous different set works to meet all requirements.

IMPROVED "HAMILTON" LATH MILL

This machine was designed and built specially for handling a large output of lath per day. It is very strong and rigid, and is made throughout of the best material. It has a capacity of sixty thousand lath in ten hours.

It is fitted with an improved device for preventing the bolts from flying back, thus making it perfectly safe to the operator.

We build a complete line of lath mill machinery, and have just issued a booklet showing this class of machinery, suitable for mills of any size, and will send a copy anywhere on request.



Head Office and Works: PETERBOROUGH, ONTARIO

Branch Office: VANCOUVER, BRITISH COLUMBIA

Up-to-Date Sawmill Machinery

Head Offices :
MONTREAL.

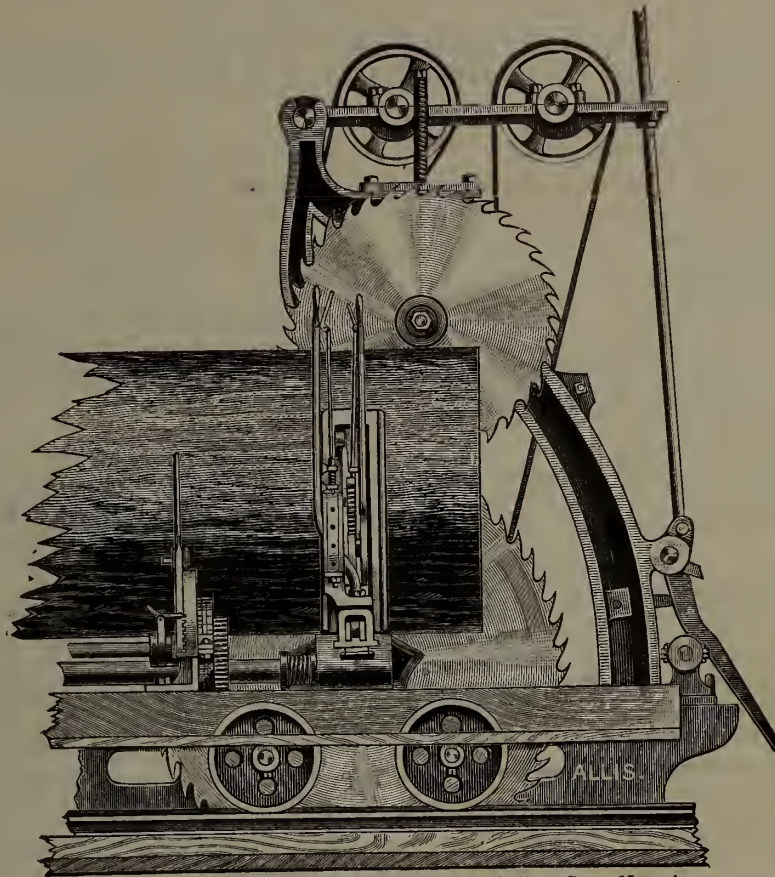

Branch Offices :
HALIFAX, TORONTO, WINNIPEG,
NELSON, VANCOUVER.

No. 1 Single Circular Mill with Inverted Top Saw Hanging.

Allis-Chalmers-Bullock, Limited

IMITATED BUT NEVER EQUALLED

40,000
Running in
Every Kind
of Timber



Perfect
in Material,
Workmanship
and Temper

GET THE GENUINE HOE CHISEL-TOOTH SAW

MADE ONLY BY

R. HOE & CO., 504 to 520 Grand Street, NEW YORK, N. Y., U.S.A.

BRITISH COLUMBIA LUMBER AND SHINGLE MANUFACTURERS

The Canadian Pacific Lumber Co., Limited
PORT MOODY, B. C.

Manufacturers and Wholesale
Dealers in All Kinds of

B. C. LUMBER, LATH, MOULDINGS, ETC.

Special Attention Given to Orders from Manitoba and the Territories † Long Distance Telephone Connection. † Address the Company at Port Moody or BYRNES & CUDDY, Selling Agents, WINNIPEG

PRTER LUND, Managing Director.

J. BRECKENRIDGE, President.

MANUFACTURERS OF
ALL KINDS OF

Grows Nest Pass
Lumber Co., Limited
WARDNER, B. C.



BUILDING MATERIAL

Capacity 150,000 Feet Per Day.

Columbia River Lumber Company, Limited

HEAD OFFICE AT GOLDEN, B. C.

Largest Capacity in Mountains

MILLS AT { GOLDEN, B. C.
BEAVER, B. C.
KAULT, B. C.
CARLIN, B. C.

ROUGH AND
DRESSED

LUMBER

FIR, SPRUCE
CEDAR AND PINE

LATH

Telephone Poles,
Piling, Etc., a
Specialty.

The Fernie Lumber Co., Limited, Fernie, B. C.

MANUFACTURERS OF AND DEALERS IN ALL KINDS OF

ROUGH AND DRESSED LUMBER

Dimension and Bridge Timber a Specialty.

Moulding in Stock or Made to Order.

JOS. GENELLE, Manager.

J. G. BILLINGS, Secretary.

THE YALE-COLUMBIA LUMBER COMPANY, LIMITED

Head Office: NAKUSP, B. C.

Mills at Nakusp, Westley, Cascade and Nelson, B. C.

We Use American Lumberman Telecode

MANUFACTURERS OF

DEALERS IN

All Kinds Rough and Dressed Lumber,
Mouldings, Lath, Etc.

Cedar and Fir Piles, Telephone and
Telegraph Poles, Fence Posts, Etc.

NORTH STAR LUMBER COMPANY,

Head Office and Shipping Yards: ELKO, B. C.

Mills: CRANBROOK, B. C.

At present we have the following material in stock at Cranbrook, B. C.:

- 1,750,000 ft. Common Boards.
- 300,000 " Stock Boards, 8 in., 10 in. and 12 in.
- 300,000 " Shiplap, 8 in., 10 in. and 12 in.
- 100,000 " Flooring, Siding and Ceiling, 4 in. and 6 in.
- 1,550,000 " Dimensions, 8 to 24 ft.

We have a large quantity of 18 and 20 ft. lengths, from 2 x 4's to 2 x 12's.

The above is manufactured from a superior quality of pine, fir and tamarack logs. 75 per cent. of it is "bone dry."

Special sized timbers cut on short notice. Write for prices

MANUFACTURERS OF AND WHOLESALE
DEALERS IN

B. C. WHITE PINE
LUMBER and LATH

Write Us About Our LARCH LUMBER

Factory Lumber
and
Tank Stock

A Specialty



BRITISH COLUMBIA LUMBER AND SHINGLE MANUFACTURERS

FIR, CEDAR
and SPRUCE
LUMBER and
FINISH

PROMPT

FIR
TIMBER, Etc.

Dressed to 30 x 30 x 90.



MOULDINGS
TURNINGS
and
LATH

SHIPMENTS

RED
CEDAR
SHINGLES

"Cascade Brand"
Always the Best

Scribner's Lumber
and Log Book

A handy book for Lumbermen.
Gives Correct Measurements of
Scantlings, Boards and Planks:
Cubical Contents of Square and
Round Timber; Doyle's Rules,
and other much practical infor-
mation.

Price 35 Cents

THE CANADA LUMBERMAN
TORONTO, ONT.

BLUE & DESCHAMPS

Manufacturers
of

Tamarac, Hemlock, Spruce
Fir, Cedar and White Pine

MILL AND OFFICE: ROSSLAND, B. C.

China Creek Lumber Co., Limited

Manufacturers of

Fir, Tamarac and Yellow Pine

WE MAKE LATH

Mill at CHINA CREEK

Office at ROSSLAND, B. C.



MAYOOK, B.C.

MANUFACTURERS OF

Larch, Pine and Fir Lumber

Large Stocks of Well Seasoned Material Always on Hand.

Mail Orders Given Prompt Attention.

Head Office: MAYOOK, B.C. - Winnipeg Office: 445 Main St.

Advertisements in the CANADA LUMBERMAN bring results—try one.



ROSS BROS. & CO.

FORMERLY OF WHITEMOUTH, MAN.

Successors to the Elkmouth Lumber Co.

ELKMOUTH, BRITISH COLUMBIA

FULL LINES KEPT IN

PINE, FIR and LARCH

Orders Respectfully Solicited.



BOWMAN
LUMBER CO. LIMITED
REVELSTOKE, B. C.

Manufacturers

Cedar, White Pine, Fir
Products.

Siding, Gelling, Mouldings and Finish.

Good Lumber and Prompt
Shipments our Specialty.

Mills at { REVELSTOKE, B. C.
COMAPLIX, B. C.

THE EAST KOOTENAY
LUMBER COMPANY LIMITED

Saw and Planing Mills at Ryan, Cranbrook and Jaffray, B. C.
Capacity 150,000 Feet per Day.



BUY E. K. L. Co.'s
LARCH

PINE AND FIR

Lumber, Timber, and all kinds of Mouldings,
also Dealers in Railway Ties, Piles and Poles.

Large Stocks of Well Seasoned
Dry Material always on hand.

HEAD OFFICE
CRANBROOK, B. C.

USE **MUNDY'S QUALITY**

AIR-DRIED LUMBER AND SHINGLES

THREE VALLEY P. O., B. C.

The Ladysmith Lumber Co., Limited
LADYSMITH, B. C.

Manufacturers of

**LUMBER, LATH, SHINGLES,
MOULDINGS, ETC.**

SPECIALTY: The best Cedar Shingles manufactured on the Coast.

FRESH WATER FIR LATH ALWAYS IN STOCK.

Capacity of Shingle Mill, 100,000 per day of 10 hours.

Correspondence Solicited

**The Cook & Bros.
Lumber Co.**

Of Ontario, Limited
MILLS at SPRAGGE, Algoma Dist., Ont.
on "Soo" Branch C.P.R.

OFFICES (Manning Arcade, Toronto
Coristine Building, Montreal
And at Mills at Spragge.

MANUFACTURERS OF

**White and Red Pine
Lumber and Lath**

Water Shipments

**For Fans, Separators, Dust Collectors
Blowers and Shavings Systems
Heating and Dry Kiln Systems**

SEND FOR CATALOGUE TO

HINRICH & PACE

Revelstoke, B. C.

Get Rid of Your Trouble

with Gears, which are eating up too much of your power, by putting in a Horizontal Setting as shown here. This is the Modern Way and also the Economical Way, for it will save you Water, Power, Time and Money. This cut shows a Globe case containing a Triumph Turbine, with elbow, two pulleys, one of which may be cut off by a clutch, and governor, all mounted on the one steel frame. This setting is self-contained, rigid and durable, and permits a direct belt drive to the machine to be driven.

Our Triumph Wheels placed horizontally give from 5 to 10 per cent. better results than any other wheel, owing to their perfect discharge. For light powers with limited water our Improved Standard Leffel and Vulcan Wheels have no equals. If you are developing a new power or replacing an old setting, let us figure with you. We can furnish any style of setting for any head or power, and our experience in this line is at your service.

We also build the Improved Lane Circular Saw Mills with capacities of from 5 to 50 M. per day, Shingle Machines and all Machinery for making lumber, lath or shingles.

Our new Tie Machine will make 1200 Ties in 10 hours. It's worth investigating.

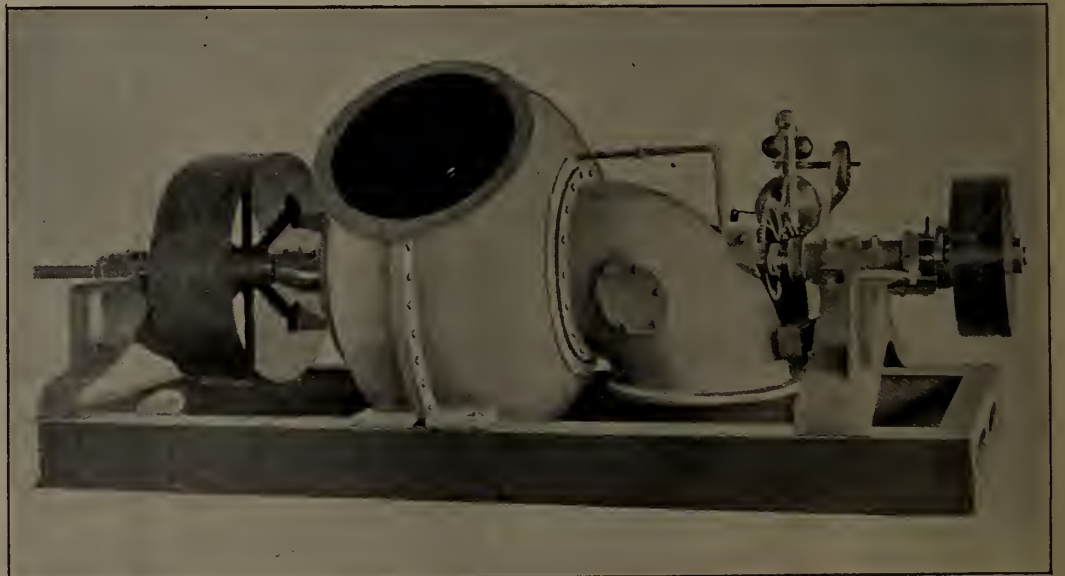

MADISON WILLIAMS

H. E. PLANT, Agent
Cor. Common and Nazareth Streets
Montreal, Que.

Successor to Paxton, Tate & Company
PORT PERRY, ONT.

Manitoba Iron Works
Western Selling Agents
Winnipeg, Man.

R. H. SMITH CO., LIMITED

— St. Catharines, Ont. —

We are the Sole Manufacturers of Saws under the

Simond's Process

in the Dominion of Canada.

There is no process its equal for tempering circular saws. Other makers recognize this fact, as some of them, in order to sell their goods, claim to have the same process. All such Claims are FALSE, as the patentee in the U. S. and ourselves are the only firms in the world who use it.



INSERTED TOOTH SAWS

Notice the improved shank. We call particular attention to the swell which strengthens it at the weakest part and which gives it more wear than the old style.

Shanks made in usual gauges and to fit your saws perfectly.

SHINGLE SAWS

The quality of the "Simonds" Shingle Saws is proven by the fact that the largest shingle and machine manufacturers in Canada are using them.

Run a "Simonds" and you will increase your output.



CROSS-CUT SAWS

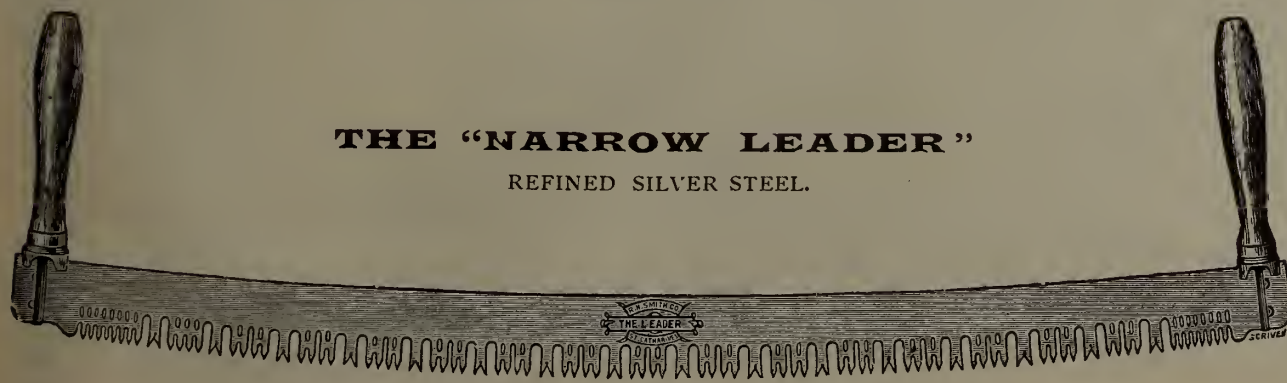

The Simond's temper and style of tooth make the "Leader" the fastest and easiest cutting saw manufactured.

Write for prices.

R. H. SMITH CO., Limited, St. Catharines, Ont.

"DEFIANCE" Wood-Working Machinery

For Manufacturing
**HUBS, SPOKES, WHEELS, WAGONS,
CARRIAGES, RIMS, SHAFTS, POLES,
NECK-YOKES, SINGLE TREES, BARREL
HOOPS.**

Handles of Every Kind, Insulated Pins, Spools,
Bobbins, Oval Wood Dishes, and General Wood-
Work.

Invented and Built by

THE DEFIANCE MACHINE WORKS,
Defiance, Ohio, U. S. A



NO. 1 HUB TURNING LATHE



32" SPOKE TURNING LATHE



The "Alligator" Steam Warping Tugs

SIDE WHEELS OR TWIN SCREWS

The Twin Screws are arranged with flexible joint to
raise up in crossing portage

MANUFACTURED BY

WEST & PEACHEY, - Simcoe, Ont.

Cables carried in stock for renewals

THE E. LONG MANUFACTURING CO., ORILLIA, ONT.

We build Double Edgers, Steam Feeds, Log Jacks, Live Rolls, Trimmers, Slab Slashers, Steam Niggers.

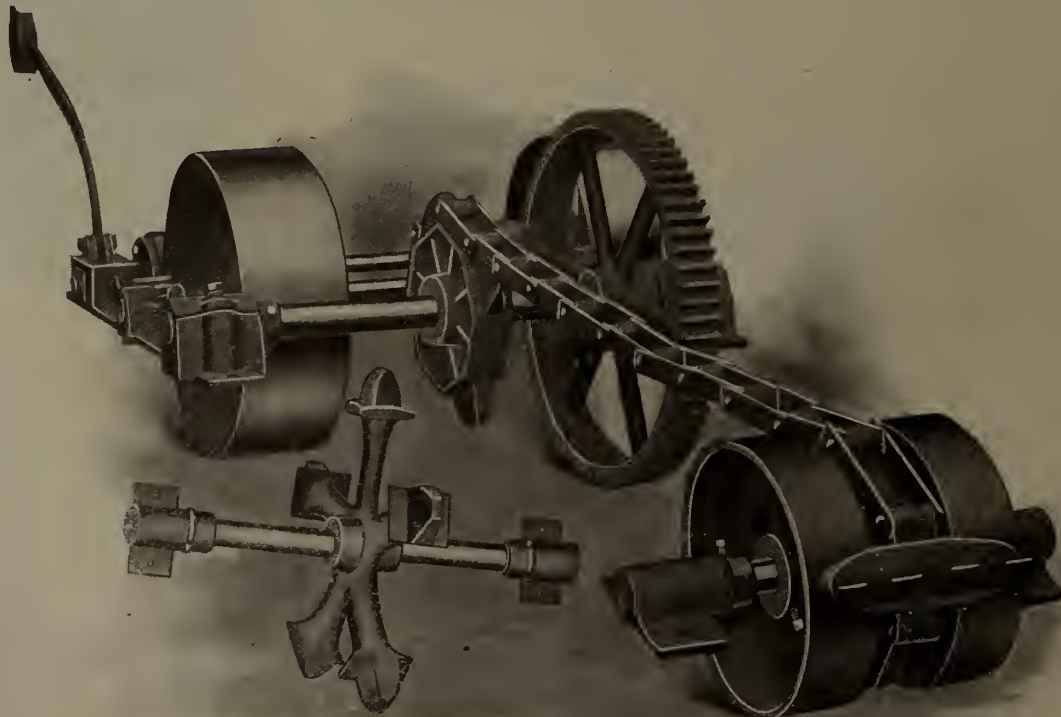

COMPLETE LINE OF SAW AND SHINGLE MILL MACHINERY
WRITE FOR CATALOGUE AND PRICES



Turin Glazed Bevel Plate.

Hand Carved. Made in "A" Quality; also in Plain Oak and Quartered White Oak. 3-0 x 7-0, 1 1/4. Plain Oak. 3-0 x 7-0, 1 1/4. Quartered White Oak.

Established 1889
Incorporated 1896

**WE SOLICIT THE TRADE
OF RETAILERS ONLY**

E. J. DAVIS MFG. CO.
21st & Morgan Streets
CHICAGO

Manufacturers of _____

**VENEERED
DOORS**

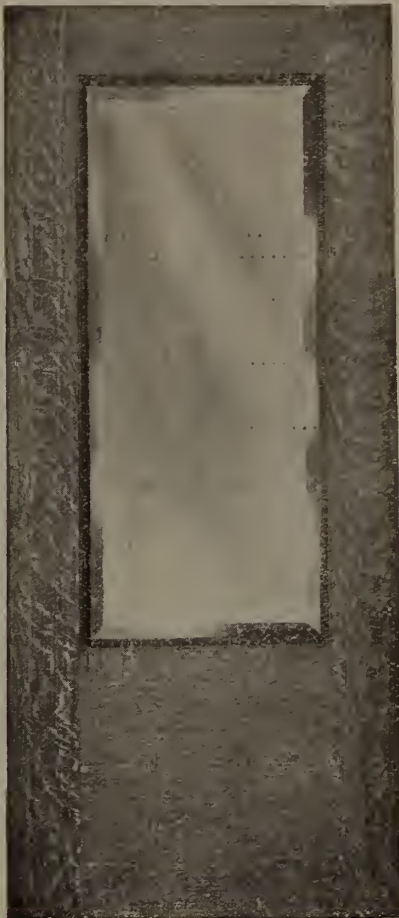

Andover.

Egg and Dart Moulding around glass; glazed with Bevel Plate Glass. Made in "A" Quality; also in Plain Red and Quartered White Oak. 3-0 x 7-0, 1 1/4. Plain Red Oak. 3-0 x 7-0, 1 1/4. Quartered White Oak.



Portsmouth Glazed Bevel Glass.

Hand Carved. Made in "A" Quality; also in Plain Red and Quartered White Oak. 3-0 x 7-0, 1 1/4. Plain Red Oak. 3-0 x 7-0, 1 1/4. Quartered White Oak.

We Solicit a Share of Your Business

E. J. DAVIS MFG. CO.
21st and Morgan Streets
CHICAGO, ILL., U.S.A.

Our Doors are known the world over and are recognized as the best made.

Send for Catalogues and Price Lists



Euclid Glazed Bevel Plate.

Hand Carved. Made in "A" Quality; also in Plain Red and Quartered White Oak. 3-0 x 7-0, 1 1/4. Plain Red Oak. 3-0 x 7-0, 1 1/4. Quartered White Oak.

CLASSIFIED INDEX OF ADVERTISERS

AXES

Dundas Axe Works..... 37
Warnock Co., James..... 39

ALLIGATOR TUGS

West & Peachey..... 8

BELTING

Beal Leather Co., R. M..... 37
Dominion Belting Co..... 38
Gutta Percha & Rubber Mfg. Co..... 41
Goodhue & Co., J. L..... 1
McLaren, D. K..... 1
McLaren Belting Co., J. C..... 44
Montreal Belting Co..... 32
Waterous Engine Works Co..... 38
Wilby, P. H..... 12
Young, J. S..... 1

BABBITT METALS

Georgian Bay Engineering Works... 43
Syracuse Smelting Works..... 44

BOILERS

Dyment Foundry Co..... 36
John McDougall Caledonian Iron Works 30
Robb Engineering Co..... 40

DOORS

New Century Refrigerator & Mfg. Co. 10
Davis Mfg. Co., E. J..... 9

DRY KILNS

Andrews Co., The A. H..... 43
McEachren Heating & Ventilating Co. 43
Sheldon & Sheldon..... 43
Standard Dry Kiln Co..... 43

DADO HEADS

Huther Bros..... 35
Mattison Machine Works, C..... 30

EMERY WHEELS

Hart Corundum Wheel Co., Limited.. 26

ENGINES AND LOCOMOTIVES

Dyment Foundry Co..... 36
Gartshore, John J..... 10
Robb Engineering Co..... 40

EDGERS

Gordon Hollow Blast Grate Co..... 40

GRATES

Gordon Hollow Blast Grate Co..... 40

INSURANCE

Lumber Mutual Fire Insurance Co.... 33
National Lumber Insurance Co..... 35
Toledo Fire Insurance Co..... 31

LUMBERMEN'S SUPPLIES

Beal Leather Co., R. M..... 37
Barr, Alex..... 12
Capstan Mfg. Co..... 35
Johnson, A. H..... 40
Park, Blackwell Co..... 37
Thompson Mfg. Co..... 32
Tobin, Joshua..... 26
Woods, Limited..... 1

LUMBER AND SHINGLE MANUFACTURERS

Bowman Lumber Co..... 6
Cook & Bro. Lumber Co..... 6
Canadian Pacific Lumber Co..... 4
China Creek Lumber Co..... 5
Crows Nest Pass Lumber Co..... 4
Columbia River Lumber Co..... 4
Cascade Mills..... 5
East Kootenay Lumber Co..... 5
Ferne Lumber Co..... 4
Ladysmith Lumber Co..... 6
Mundy Lumber Co..... 6
Mayook Lumber Co..... 5
North Star Lumber Co..... 4
Ross Bros. & Co..... 5
Staples, Otis..... 4
Yale-Columbia Lumber Co..... 4

LUMBER DEALERS

Knight & Co., G. T.....
Osborne & Clark..... 34
Sanford Furniture & Woodenware Co. 32

LUMBERMEN'S TOOLS

Hay Knife Co., Peter..... 35
McFarlane Neill Mfg. Co..... 44
Pink, Thomas..... 44
Sanford Logging Tool Co..... 32
Warnock Co., James..... 39

LUMBERMEN'S AGENTS

Friel, H. J..... 38
Wright, H. J..... 38

LUMBERMEN'S BOOKS

Leaver, J. M..... 32

MISCELLANEOUS

Alexander Engraving Co..... 37
Bradstreets..... 10
Canadian Office & School Furniture Co. 10
Clyde Iron Works—Log Loaders.... 38
Canadian Typewriter Co..... 33
Denton, Dunn & Boulbee, Barristers. 32
Fielding, J. S., Consulting Engineer.. 35
Georgian Bay Engineering Works—
Grinders..... 43
Manitoba Gypsum Co.—Plaster..... 30
Midland Engine Works Co.—Tram
Car Wheels..... 12
Northwest Steel and Iron Works.... 32
Superior Mfg. Co.—Log Stamps..... 35
Spence & Co., R.—Files and Rasps.. 10
Saw Gummer, A. T. McLatchie..... 32
Sessenwein Bros.—Rails..... 27
Saw Mill for Sale—Box 775, New York 41
Vogel, C. H.—Pulp Mill Engineer.... 32

OILS.

Commercial Oil Co..... 38
Queen City Oil Co..... 10

PROVISIONS

Eckardt & Co., H.P..... 25

PORTABLE SAW MILLS

Drake, F. J..... 36

PLANERS AND MATCHERS

Cowan & Co..... 38

PACKING AND PIPE COVERING

Garlock Packing Co..... 12
Purvis Co., E. L..... 38

ROPE

Consumers Cordage Co..... 33
Dominion Wire Rope Co..... 12
Greening Wire Co., B..... 35
Mussen & Co., W. H. C..... 1

ROOFING

Bird & Son, F. W..... 34

RE-SAWS

Cowan & Co..... 38

SAW SWAGES

Hanchett Swage Works..... 27

SAWS

Atkins & Co., E. C..... 38
Burns Saw Co., E. R..... 1
Canadian Saw Co..... 34
Hoe & Co., R..... 7
Smith Co., R. H..... 7

SAW MILL MACHINERY

Allis-Chalmers-Bullock..... 3
DeLoach Mill Mfg. Co..... 32
Gordon Hollow Blast Grate Co..... 40
Hamilton Mfg. Co., Wm..... 2
Hinrich & Pace..... 6
Jenckes Machine Co..... 37
Kendall, I. N..... 41
Long Mfg. Co..... 8
Lloyd Mfg. Co.....
Mershon & Co., W. B..... 35
Manitoba Iron Works..... 33
Mowry & Sons, B. R..... 41
Petrie, H. W..... 1
Payette & Co., P..... 33
Payne Machinery Exchange Co..... 32
Smart-Turner Machine Co..... 44
Savoie-Quay Co..... 34
Waterous Engine Works Co..... 42
Williams, Madison..... 6

SHINGLE MILL MACHINERY

Drake, F. J..... 36
Long Mfg. Co., E..... 8
Perkins & Co..... 12
Williams, Madison..... 6

TURBINES

Jenckes Machine Co..... 37
Williams, Madison..... 6

TRIMMERS

Gordon Hollow Blast Grate Co..... 40

WOODWORKING MACHINERY

Adde & Co..... 34
American Woodworking Machinery
Co..... 11
Cowan & Co., Limited..... 7
Defiance Machine Works..... 8
Rogers Iron Mtg. Co..... 37
Sherman Co., W. S..... 40
Shimer & Sons, Samuel J..... 41
Waterous Engine Works Co..... 42

The . . .

QUEEN CITY OIL CO. LIMITED

Head Office: TORONTO.

HIGHEST GRADES OF

Refined Oils

Lubricating Oils

AND ALL

Petroleum Products

CANADIAN OFFICE & SCHOOL FURNITURE CO. LIMITED

PRESTON ONT.

FINE BANK OFFICE, COURT HOUSE & DRUG STORE FITTINGS.

OFFICE, SCHOOL, CHURCH & LODGE FURNITURE

SEND FOR CATALOGUE

ESTABLISHED 1849.

BRADSTREET'S

Capital and Surplus, \$1,500,000.

Offices Throughout the Civilized World.

Executive Offices:
Nos. 346 and 348 Broadway, NEW YORK CITY, U.S.A.

THE BRADSTREET COMPANY gathers information that reflects the financial condition and the controlling circumstances of every seeker of mercantile credit. Its business may be defined as of the merchants, by the merchants, for the merchants. In procuring, verifying and promulgating information, no effort is spared, and no reasonable expense considered too great, that the results may justify its claim as an authority on all matters affecting commercial affairs and mercantile credit. Its offices and connections have been steadily extended, and it furnishes information concerning mercantile persons throughout the civilized world.

Subscriptions are based on the service furnished, and are available only by reputable wholesale, jobbing and manufacturing concerns, and by responsible and worthy financial, judiciary and business corporations. Specific terms may be obtained by addressing the company or any of its offices. Correspondence invited.

THE BRADSTREET COMPANY.

OFFICES IN CANADA: Halifax N.S. Hamilton, Ont. London Ont.; Montreal, Que.; Ottawa, Ont.; Quebec, Que.; St. John, N. B. Toronto, Ont. Vancouver, B.C.; Winnipeg, Man.

THOS. C. IRVING,
Gen. Man. Western Canada, Toronto

RAILS For Logging Tramways, Switches Etc.
New and Second-Hand.

YARD LOCOMOTIVES

John J. Gartshore
83 Front St. West,
(Opposite Queens Hotel) Toronto.

R. SPENCE & CO

Beech File Works.
HAMILTON, ONT.
FILE AND RASP MANUFACTURERS AND RE-CUTTERS

A trial order solicited. Write for price list and terms.
C. P. MOORE, PROPRIETOR.

New Century Refrigerator & Manufacturing Co., Limited

Dundas, Ont., Can.

Our Business is Manufacturing

HARDWOOD VENEER . . . DOORS

With Built Up Bodies

These Doors are guaranteed not to warp or twist and are superior in construction and finish to any other Door on the market.

Send for Illustrated Catalogue and Prices.

Special attention given to Architects' Designs of Doors and Trims.

AGENTS WANTED EVERYWHERE. ADDRESS DOOR DEPARTMENT

Thirty-Two Years Experience in Building Moulders Enables Us to Give You the Best Machine for Your Work. Write Us.

HOUSTON TYPE AMERICAN IMPROVED 10" FOUR-SIDED MOULDER

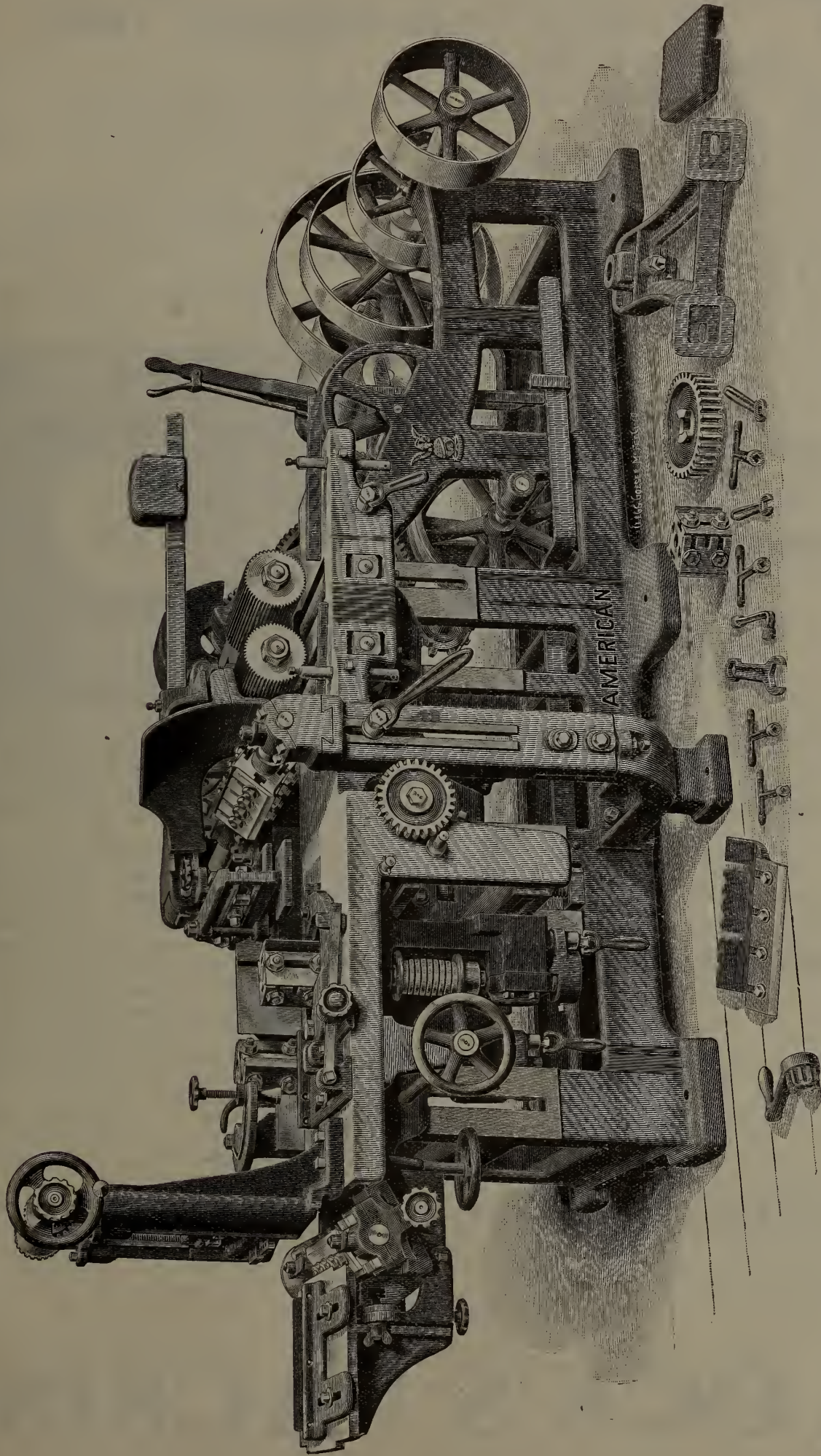

For Full Particulars Regarding any Wood Working Machine Address

American Wood Working Machinery Co.

The Canadian Fairbanks Co.,
Montreal and Vancouver

New York City,
136 Liberty St.



TEON BELTING



STEAM PFOOF
WATER " "
HEAT " "
OIL " "
ACID " "

Stronger and Cheaper than Leather.

LEATHER BELTING
CAPATA BELTING [BALATA TYPE]

CAMELS HAIR BELTING
LACE LEATHER, Etc.

Special Arrangements for Trial Belts.
Write for Price Lists and Discounts.

P. H. WILBY, 27 1/2 Front Street East, TORONTO
Phone Main 1930. SOLE AGENT FOR CANADA.

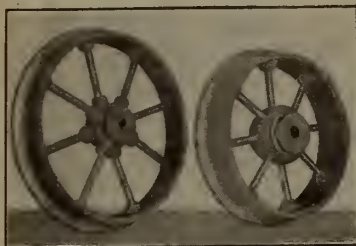

Our special Tram Car Wheels

made from a special mixture of Iron, are stronger, longer lived, low in price and lighter for their strength than any other wheel. Write for prices and samples of metal.

MIDLAND ENGINE WORKS CO.
MIDLAND, ONT.

WIRE ROPE FOR ALL PURPOSES IN STOCK

SPECIAL ROPES FOR LUMBERING
BLOCKS - CLIPS - TURNBUCKLES - ETC.

The DOMINION WIRE ROPE CO., Ltd.
MONTREAL

EVERY LUMBERMAN WANTS IT

35 cents buys it

Scribner's Lumber and Log Book

BRIMFUL OF EVERY-DAY
PRACTICAL INFORMATION

Address :
THE CANADA LUMBERMAN, Toronto

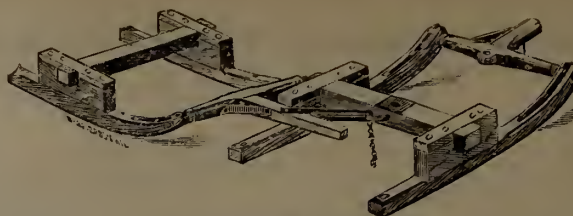

THE LUMBERMEN'S FRIEND

(Desjardin's Patent)

ALSO

Heavy Runners for Logging Sleighs
Bent to Order, Poles, Beams, Rollers,
Blocks, and other parts on
hand at all times.

I ALSO MAKE
Boom Chains
Logging Chains
Skiddin Tongs
Clevis' Heavy
Neckyokes and
Whiffletrees

Large
DUMPING WAGONS
for Mill Yards a
Specialty

ALEX. BARR

WRITE FOR PRICES

Manufacturer

Pembroke, Ont.



A POSITIVE FACT ADMITS OF NO ARGUMENT

Granted that's true, are you open to conviction on the fact that the COLUMBIA SHINGLE MACHINE will produce 1000 additional shingles from every 1000 feet of logs? And that it will produce more and better shingles from the same stock, using same kerf, than any other similar machine?

If you are, we'd like to demonstrate to your entire satisfaction the truth of these positive facts, and that you can't afford to make your shingles on any other machine. Isn't it up to you?

Write us.

PERKINS & CO., - GRAND RAPIDS, MICH.



Garlock Packing Co.

HAMILTON

CANADA

—SOLE MANUFACTURERS OF—



GARLOCK'S PACKINGS

PATENTED

Asbestos and Mineral Wool Pipe and Boiler Coverings, Engineers' Supplies in General

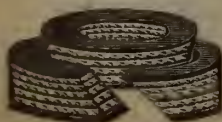

THE CANADA LUMBERMAN AND WOOD-WORKER

VOLUME XXV. }
NUMBER 12. }

TORONTO, MONTREAL — DECEMBER, 1905 — WINNIPEG, VANCOUVER

{ TERMS, \$1.00 PER YEAR
Single Copies, 10 Cents }

THE LATE MR. JOSEPH TURNER.

The portrait of the late Mr. Joseph Turner, to whose death reference was made in the November number, is presented on this page. Deceased was president of the Turner Lumber Company and a gentleman who was very highly esteemed.

It is learned that his extensive lumbering operations in Ontario, reaching about fifty million feet annually, will be continued by his sons, who have for some years been associated with him in business. The new officers of the company are: Dwight J. Turner, president; Clarence A. Turner, vice-president; Stanley F. Turner, secretary-treasurer.

The head offices of the company have been removed from Midland to Toronto, although representatives will still be permanently located at Midland, South River and Cutler.

FIRE PROTECTION ALONG RAILROADS.

The escape of glowing coal from the ash-pan and of sparks from the smoke-stack, especially the latter, has been one of the most fruitful sources of forest fires wherever steam railway construction and operation are conducted on forested lands.

Much may be done by using spark arresting screens in the extension front of the locomotives, by care in firing, and by forbidding the dumping of glowing coals when engines are in motion. Unfortunately, no device has yet been perfected by which the escape of sparks from the smokestack may be entirely prevented, and the safety of the forest must be sought by the combined use of such safeguards as are found to be practicable, together with an efficient patrol of the right of way.

At the Quebec meeting of the Canadian Forestry Association in March, 1905, the following timely resolution was unanimously adopted:

Resolved, that in view of the proposed construction of a new transcontinental railway and the projection of other lines passing largely through coniferous forests, the attention of the governments of the Dominion and the provinces, and also of the railway companies, be called to the serious danger of loss of valuable timber consequent upon the construction and operation of such lines, if all possible precautions to prevent the starting of fires are not taken, and to urge that the question be given full and careful consideration, that to the end

sought the party or parties contracting to build the different sections of the said roads be required to enter into an agreement for an efficient equipment and control to prevent fires, that at such seasons as may be necessary an effective patrol be established along the afforested line of railway, and that the officers both of the governments and the railways be required to use all possible diligence to prevent the starting or spread of fires through defective equipment or through the carelessness of



THE LATE MR. JOSEPH TURNER.

the operators or negligence of the employees under their control.

The following review of an article in the *Centralblatt für das gesammte Forstwesen*, June 1905, pp. 271-274, on this timely topic, is quoted from the *Forestry Quarterly*, vol. III, No. 3, p. 311. An interesting feature of the official regulations of the Prussian government noted in this article is the insistence of a close forest cover being maintained as near as is practicable to the rails. It is, of course, absolutely necessary to clear the forest away a sufficient distance to enable the engineers to see their signals and to prevent accident by windfalls across the rails. Beyond this necessary clearing, however, the more completely the forest cover is maintained the less the danger from fire.

"The latest formulation of measures to protect forest areas against fires from locomotives was made by Dr. Kienitz in the German Forstwirtschaftsrath in February.

"Recognizing that the railroad companies can reduce, but by no means avoid entirely, the escape of fire from the locomotives, and that with increased traffic an efficient patrol system becomes practically impossible, the necessity of safety appliances along the right of way is argued. The cost of these appliances must, of course, be kept in proportion to the result, and the more endangered forests (conifers on dry soil) call for greater care. These appliances may be merely woven wire-fences or light metal fences (applicable only near civilization) or else cleared or planted safety-strips.

"The best safety-strips are not open but wooded strips of moderate width with trees dense enough and high enough to prevent the passage of glowing coals and in such a condition that a fire if started goes out of itself.

"Open safety-strips even if the ground is kept plowed, which is the best means of preventing fires, are less desirable, because, to be effective, they must be broader than is usually practicable—100 feet on each side is still insufficient—and if not fit for farm use constitute a great waste.

"The construction of such safety-strips is based on the observation of the manner in which fires originate and propagate. All fires originate on the ground, stem and top fires included which run up from the ground if inflammable material intervenes and go out when the ground fire is stopped.

"The ground fire in its incipience goes out by itself when meeting small impediments of non-inflammable material, a plough-furrow, a trail; it becomes more dangerous as it increases in circumference. Hence excessive breadth of the safety-strip (without plough-strips or trails) may become a source of danger.

"The safety against fire is not to be sought so much in the non-inflammability of the green leaves as in the absence of dry branches and the presence of non-inflammable bark. The thick bark of a pine makes it the most resistant species; but the soil cover is, of course, the main source of danger.

"Upon the basis of these general principles the Prussian Ministry of Agriculture and Forests has issued specific instructions for the construction and maintenance of safety-strips. These are to have a breadth of 40 to 50 feet

with a plowed strip or trail or road or ditch or otherwise open ground of 3 feet width along the embankment, and another such strip of 4 to 5 feet on the opposite side of the wooded strip; the first to prevent fires running into, the latter to prevent fires from running out of the safety-strip. Within the latter all easily inflammable material is to be removed and trees are to be trimmed up to 4.5 feet. Only the green branches on the side toward the railroad are never to be removed.

"The two plowstrips (paralleling the roadway) are to be connected every 75 to 100 feet by cross strips, to confine possible fires still further. In moorlands sanding over these strips may be necessary.

"In new railroad constructions the opening through the forest is to be *made no wider than the absolute necessity of safe railroading requires*. Where danger from windfalls is to be anticipated the opening is to be widened as far as necessary, *to be at once reforested*.

"For this reforestation on sandy soils especially the Scotch Pine yearlings or three-year old transplants (4 x 4 feet) are to be used, and Spruce for better sites. Until the plants are about 3 feet high, the ground is annually in the spring cultivated. When the lower branches begin to die they are trimmed off, and all dead plants are removed; but every green twig is preserved."

LUMBER STRAIGHTENER AND PILER.

Mr. George H. Whistle, of Toronto, has been granted a patent, No. 92,896, for a lumber pile straightener and lumber piler, shown by the accompanying drawings. The statement

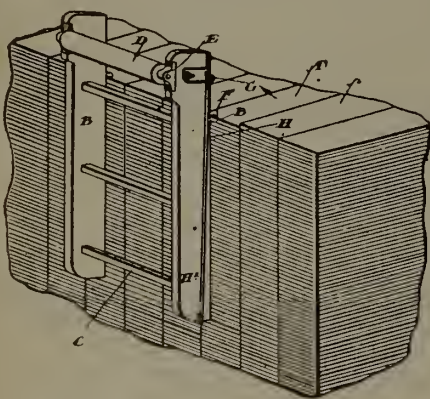

Fig. 1

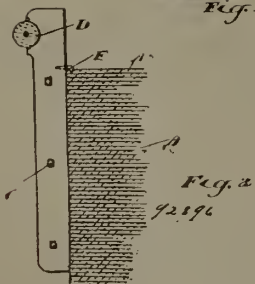

Fig. 2

LUMBER STRAIGHTENER AND PILER.

of his claim for the new invention is as follows:

1. A combined lumber pile straightener and lumber piler comprising the uprights, cross bars connecting them, the spurs extending inwardly from the inside edge of the uprights, and the roller journaled in suitable bearings on the uprights.

2. A combined lumber pile straightener and lumber piler comprising the uprights, cross bars connecting them, the spuds extending inwardly from the inside edge of the uprights,

the roller journaled in suitable bearings on the uprights and handles secured on each upright.

3. A combined lumber pile straightener and lumber piler comprising the uprights suitably connected together and having an index line marked on one side thereof and located farther away from the inside edge of the upright at the bottom than at the top, and a plumb line designed to register with such line, and means for hanging the uprights upon the edge of the lumber pile.

4. A combined lumber pile straightener and lumber piler comprising the uprights suitably connected together and having an index line marked on one side thereof and located farther away from the inside edge of the upright at the bottom than at the top, a plumb line designed to register with such line, and spuds having bent spike-like ends designed to extend into the edge of the boards of the lumber pile.

MODERN SINGLE BAND HARDWOOD SAW MILL.

On the opposite page are shown the plans of an approved type of a single band saw mill especially adapted for the cutting of hardwoods. It was recently constructed by Messrs. Bliss & Van Auken, of Saginaw, Mich., who have had many years experience in the building and running of saw mills of many types, this mill being erected by them as the result of all these years of experience. It has been thoroughly worked out and demonstrated that for cost, efficiency, economy in the number of men employed and output, it fully equals or excels the best mills of this type ever erected. The plans, which are reproduced by permission from the Hardwood Record, of Chicago, show a mill 30x96 feet in size, and illustrate the machinery floor, saw floor and the filing room in the third story. The mill is equipped with machinery manufactured by the M. Garland Company, of Bay City, Mich. This equipment is made up of an eight-foot band mill, a three carriage, a three saw edger, a trimmer and a slasher. The carriage is fitted with Prescott steam set works manufactured by the Prescott Company, Menominee, Mich.

The machinery is actuated by a rope drive, which, with pulleys and shafting, was installed by the Dodge Manufacturing Company, of Mishawaka, Ind. The mill is very closely connected, and is entirely free from complicated appliances. The arrangement of carriage, live rolls, etc., permits of sawing timber up to twenty-four feet in length. In the case of Bliss & Van Auken this equipment was put in to accommodate the sawing of hemlock, although the chief output of the mill is maple cut to one inch, which is manufactured to supply their flooring factory.

The regular output of the mill in a ten hour run is from 26,000 to 30,000 feet of one inch hard maple, and from 45,000 to 55,000 feet of hemlock, cut to one and two inches, and timbers. The maple logs average ten to the thousand, while the hemlock runs eight to the thousand. This entire sawmill construction and equipment cost less than \$20,000.

There are some peculiar features connected with the great Bliss & Van Auken enterprise

at Saginaw. In addition to this sawmill, they operate a custom planing mill; a maple flooring factory; a plant for the manufacture of roller bearings; another for the construction of gasoline pumping engines, and still another in which windmills and water-tanks are made. Besides this, they are producers of salt, and supply power for the running of some minor plants in the vicinity. The power for this entire list of manufacturing enterprises is supplied from one power plant which consists of a 350 h.p. upright, water tube boiler, actuating a 24x48 Corliss engine. The engine is belted direct to the planing mill, and by means of a rope-drive to the sawmill, while it also actuates a large dynamo which supplies the electric current which drives the individual machines in the flooring plant and the other factories enumerated. This engine is in constant service from Monday morning to the following Sunday morning, although but a small number of the plants are run at night.

The logs with which this mill is supplied are delivered from the Company's timber purchase at Haakwood, on the Mackinaw division of the Michigan Central, by train, and are dumped into a steam-heated log pond contiguous to the mill. The flooring plant is a small and compact one which produces about 18,000 feet of maple flooring in a ten-hour run. Every machine has direct motor connection. The system employed in making flooring at this plant is what is known as the edge tongue and grooving. The maple lumber as it comes from the dry kiln is stripped and the knot defects cut out. The strips are then double surfaced on a Twin Hoyt machine; they are then end matched, and the best surface scraped. The next operation consists in tonguing and grooving, which is performed on a fast running Hoyt edge matcher, manufactured, like the other Hoyt tools, by the American Woodworking Machinery Company. This machine dresses and matches, hollow-backs and bores for blind nailing. The floor material is then assorted, and the bundles are transferred to the warehouse by means of an endless belt conveyor. All the flooring is loaded into cars under cover.

The Canadian Fairbanks Company, Montreal, intend publishing a monthly bulletin in the interests of their business. It will be called "The Fairbanks Standard." The Company will be glad to place any of our readers who may be interested on their mailing list.

The William Hamilton Manufacturing Company, of Peterboro, Ont., have just issued a catalogue devoted entirely to lath mill machinery. Illustrations are shown of their Pacific Coast gang lath bolter, improved "Hamilton" lath mill and bolter, No. 1 gang lath mill and bolter, binder and trimmer, etc.

The Pratt & Whitney Company, of Hartford, Conn., have purchased a plant in Dundas, Ont., for the manufacture of its full line of small tools, taps, reamers, milling cutters, punches, dies, etc. The building is a modern structure and the power plant is already in place. The machinery equipment is being gotten ready and will be sent there and operations begun immediately. This plant will also include a department for manufacturing a full line of twist drills, an elaborate equipment of special machinery having been purchased for this purpose. The output of this new factory will be handled by the Canadian Fairbanks Company, Limited, who will have the exclusive sales agency for Canada.

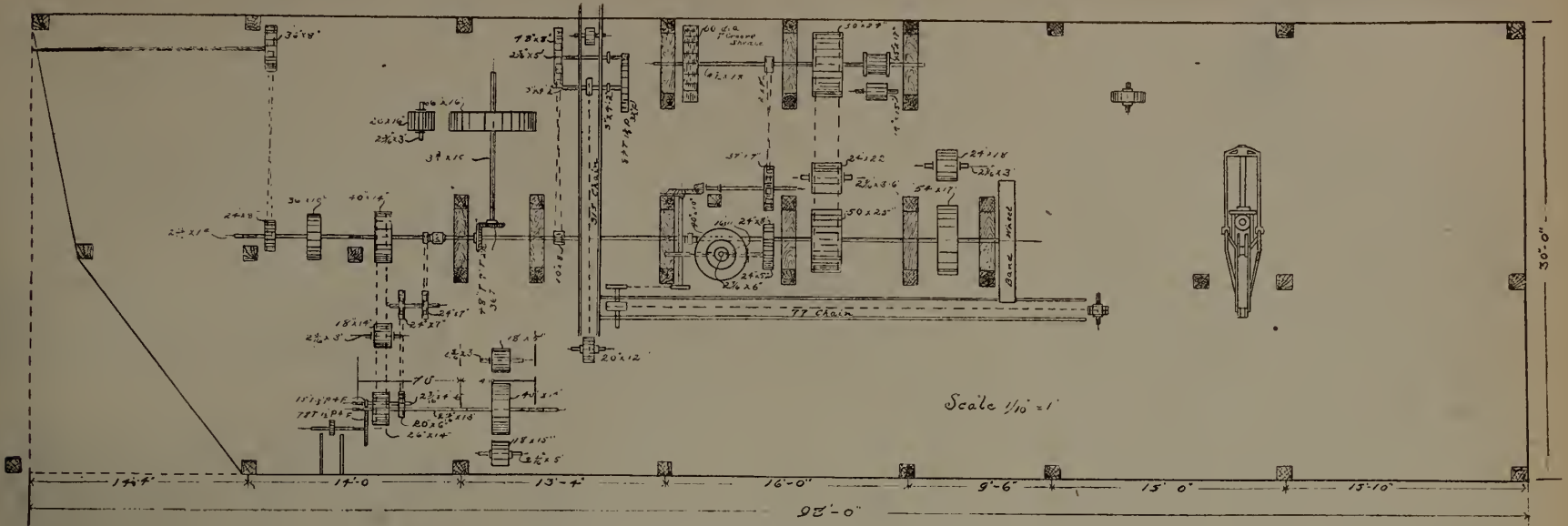

PLAN OF MACHINERY FLOOR, SINGLE BAND MILL.

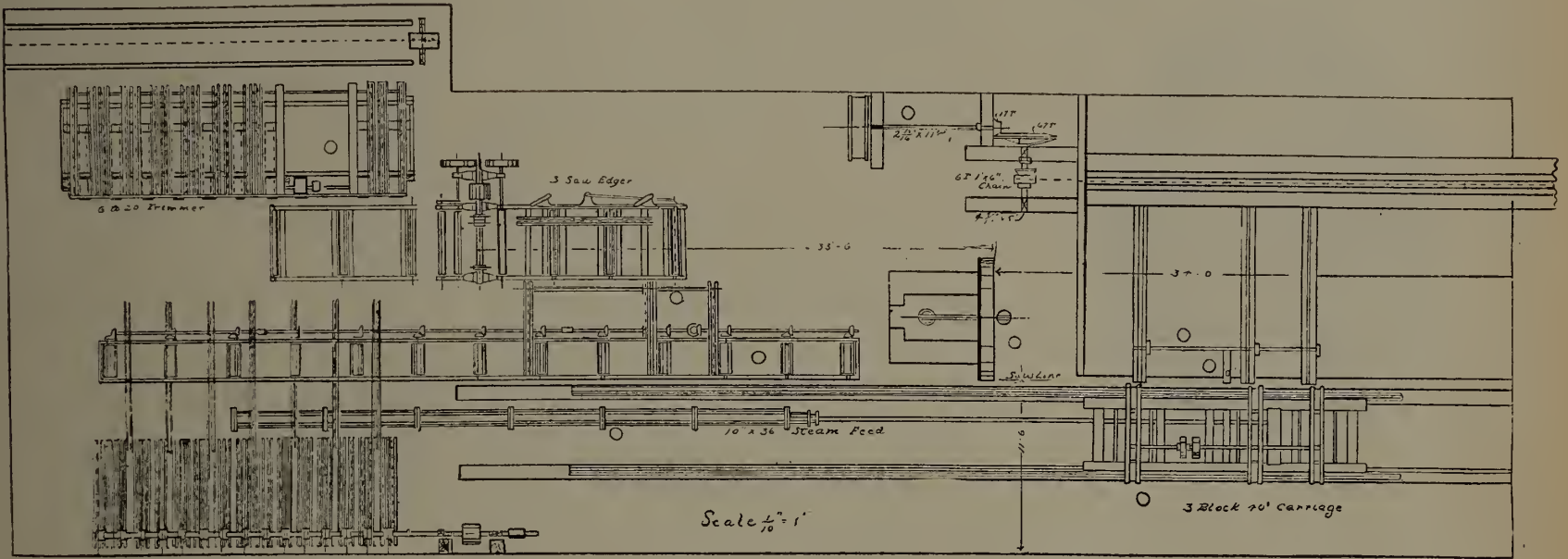

PLAN OF SAW FLOOR, SINGLE BAND MILL.

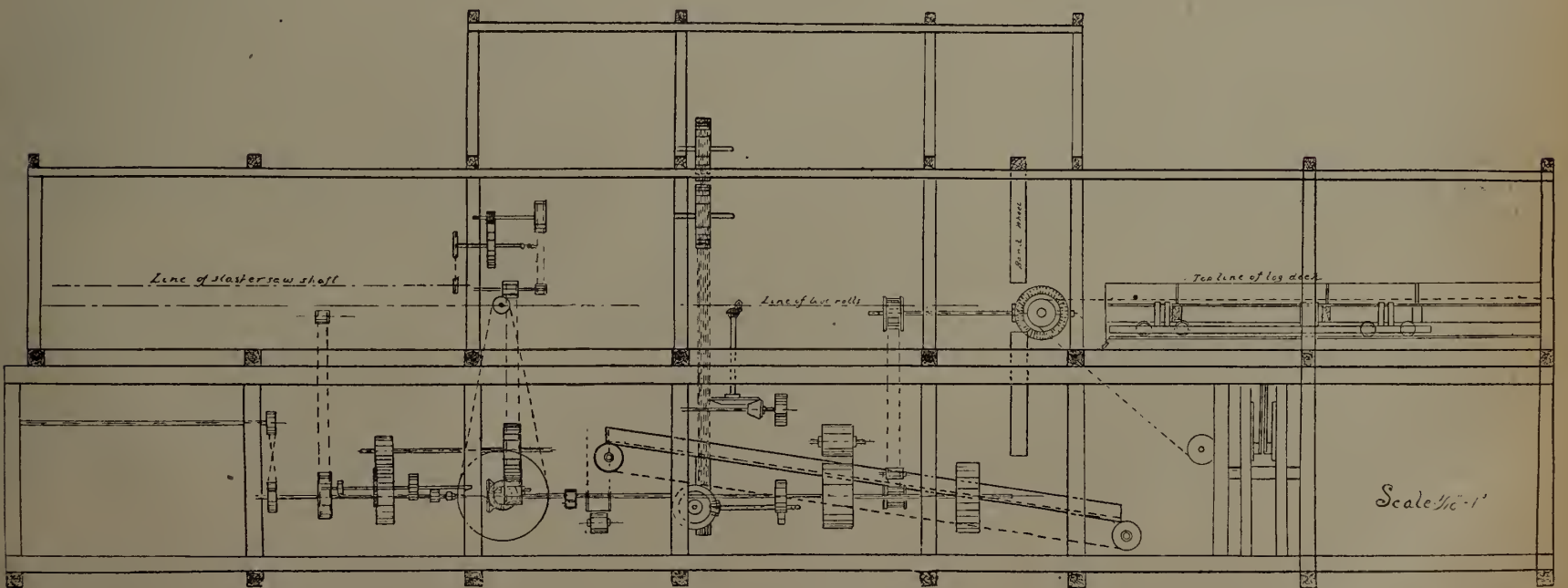

ELEVATION OF SINGLE BAND MILL.

PLANS OF A MODERN SINGLE BAND HARDWOOD MILL.

What Old-Time Subscribers Say of the "Canada Lumberman and Wood-Worker."

Glancing over the mailing list of the CANADA LUMBERMAN, the publishers have felt gratified to observe the considerable number of subscribers of long standing. Of a subscription list of three thousand, and which is steadily growing, two hundred and seventy-two have been subscribers for between ten and twenty-three years, which fact may, we think, be accepted as tangible evidence that our efforts to produce a journal of interest and value to the lumber trade have met with a fair measure of appreciation and success. The honor of being the oldest subscriber belongs to Mr. J. Breakey, the well-known mill owner of Quebec city, whose address label bears the date "January, 1883." This honor is closely contested by Mr. George Cormack, who has conducted a wholesale lumber business at Whitby, Ont., for many years and has been a subscriber since October, 1883. Mr. C. Mickle, of the lumber manufacturing firm of Mickle, Dyment & Company, Gravenhurst, Ont., is the third oldest subscriber, having been a constant reader of the journal since October, 1885, while among those who subscribed in 1886 and are still on the list are Messrs. C. P. Holton, Belleville, Ont.; A. D. Ritchie, Three Rivers, Que.; Jos. Bedard, Richmond, Que.; J. C. Schliehauf, West Lorne, Ont.; J. Sheppard & Son, Sorel, Que.; Alex. Mustard, Brucefield, Ont.; Vigars Bros., Port Arthur, Ont.; S. H. Craig, London, Ont.; W. J. Reid, Ayr, Ont., and Jas. Carswell, Renfrew, Ont. What a few of the subscribers say of the paper, after a test of ten years and upwards, may be of interest to the trade, and is printed below:

GEO. RATHBONE, manufacturer of sash, doors, blinds and mouldings, dealer in pine, hemlock and hardwood lumber, Toronto: I have much pleasure in stating that I have found the CANADA LUMBERMAN AND WOOD-WORKER of very great service to my business; I consider it a medium that was greatly needed in the interests of the producer and consumer of lumber, and I think both parties have benefited by its publication. It gives a great deal of valuable information to the manufacturers and dealers in lumber, and assists them in many ways, through making known to each other their requirements in your columns.

J. C. PRESCOTT, lumber manufacturer, Albert, Albert Co., N.B.: I don't know that I have any suggestions to make toward the betterment of THE LUMBERMAN. It is all right as it is. As all of my lumber, or about all of it, goes to foreign markets, the CANADA LUMBERMAN as an advertising medium is quite an advantage to me in keeping me posted in regard to the markets, etc. I hope it will continue to prosper and will do all I can to further its interests.

JONES BROS., Katrine Station, Ont.: We are pleased at your appreciation of continuous support as you put it, but we assure you that no thanks are due us—"the shoe is on the other foot." The CANADA LUMBERMAN is all right and improving all the time, and must be a help or become almost a necessity to all lumbermen. Hoping that continued success and improvement will be yours, and that all your subscribers will carefully examine their labels to save you the trouble of drawing their attention to it.

JAMES SHEPPARD & SON, dressed lumber, mouldings, etc., Sorel, Que.: We have much pleasure in stating that the CANADA LUMBERMAN is an up-to-date journal as far as the lumber business is concerned, and is

indispensable to lumbermen. We have frequently used the "For Sale" and "Inquiry" columns, and they have always been satisfactory to us.

S. ANGLIN & CO., lumber merchants, Kingston, Ont.: We always find something of interest and profit in your Weekly and Monthly.

ALEX. MCCOOL, lumber manufacturer, Pembroke, Ont.: Regarding the merits of your journal, I must say I could not suggest anything in the way of improvement. I have been a subscriber to THE CANADA LUMBERMAN AND WOODWORKER for over twelve years, and I hope to continue on, as the paper is always full of valuable information. It should be in the hands of every man connected with the lumber business, also every foreman, mill-wright, filer and sawyer.

A. E. ALEXANDER & SON, hardware merchants, Campbellton, N.B.: Have taken your journal for some time and like it well. As sickness forced me to quit the active lumber business four years ago, I don't take as much interest as formerly, but still I will continue to be a subscriber and would not wish to be without it.

GEORGE LEIGHTON, dealer in lumber, lath and shingles, Harriston, Ont.: I receive the CANADA LUMBERMAN regularly and am very much pleased with it. I fully believe that every lumberman and dealer should be a constant reader of it, as it is a great benefit to them in their business. With best wishes for your continued success.

THE HORWOOD LUMBER CO., LIMITED, St. John's, Nfld.: We like your lumber journal very much and find its perusal a constant pleasure and profit.

R. NICHOLSON, dealer in lumber, manufacturer of sash, doors, mouldings, etc., Strathroy, Ont.: I am pleased to say that I find your paper very interesting to me as it keeps me informed of prices, etc. It is a paper no lumberman should be without.

A. K. VAN WYCK, Banner planing mill and saw mill, Parkhill, Ont.: I have always regarded your publication as indispensable to mill men. It certainly contains a world of information that cannot be got without it. Wishing you success beyond your expectations.

CANADA FURNITURE MANUFACTURERS, LIMITED, Woodstock, Ont.: Your paper has been coming to our office continuously for the last ten or twelve years, and we are very much pleased to say that we read it with a great deal more carefulness than several other publications for which we subscribe. We have obtained a great deal of valuable information, and we find that its market quotations are safeguards in regard to the prevailing prices and conditions of the lumber market. Hoping that in future you will be attended with a full measure of commercial prosperity.

CLARKE BROTHERS, lumber, Bear River, N.S.: Regarding the CANADA LUMBERMAN, we consider it the best periodical that we know of, devoted to the interests it advocates. It has always been a welcome visitor and receives careful perusal. Where it is of such uniform excellence, it is a difficult matter for us to suggest anything in the way of improvement.

H. CARGILL & SON, manufacturers of and dealers in doors, sash, blinds, flooring, etc., Cargill, Ont.: We have always found the CANADA LUMBERMAN of very great benefit to us in our business, sometimes getting ideas which would pay for almost innumerable subscriptions. We cannot suggest any improvement at this writing but will advise you should any occur to us.

UNITED FACTORIES, LIMITED, brushes, brooms and woodenware, Newmarket, Ont.: We have been taking the CANADA LUMBERMAN for a number of years, and

while we are not at present directly interested in the manufacture of lumber as we were at the time we first subscribed for your paper, yet we consume a very large quantity of lumber in our factories. We would say to you that we find the CANADA LUMBERMAN to be very valuable to us in that line, both with regard to market quotations and the articles written in connection with the lumbering industry, and we wish you every success in the publication of it.

WILLIAMSON & CROMBIE, saw, planing, clapboard and shingle mills, Kingsbury, P.Q.: We are pleased to express our appreciation of your journal, the CANADA LUMBERMAN AND WOOD-WORKER, which we consider to be one of the very best of its kind.

SHEPARD & MORSE LUMBER COMPANY, manufacturers and wholesale lumber dealers, Burlington, Vt.: We take great pleasure in saying that we consider your paper one of the best lumber journals published, and while we subscribe for a number of lumber journals, we enjoy reading the CANADA LUMBERMAN the best of all.

JOHN A. MORRISON, PHOENIX MILL, Fredericton, N.B.: I am very well satisfied with your paper. My business is in the soft woods and the New England market. You are giving your subscribers all the information that we can expect, and it affords me satisfaction when your paper both weekly and monthly come to hand. I read it all.

W. W. CARTER, manufacturer of pine and hardwood lumber, staves, hoops and headings, Fesserton, Ont.: I have been a subscriber to your CANADA LUMBERMAN for the past ten years and during that time I have always found the LUMBERMAN right up-to-date in lumber news, keeping its patrons fully posted with all prices, etc.; it comes as a welcome visitor every week, and no lumberman should be without it for the small price of the subscription.

DAVID ROSS, Whitmouth, Man.: I fully realize the benefit that your paper is to the lumber trade of Canada, and no reader could put a higher value upon its merits than the writer of this letter, and the trade owe you a debt of gratitude that is beyond price. Go on with your work and your reward must follow.

ED. C. NICHOLSON & SON, sash, door and blind factory, St. Catharines, Ont.: The CANADA LUMBERMAN is a clean cut and up-to-date paper—a welcome visitor. It puts us in touch with what is doing all around us. The first thing we look for is the trade reports. The cuts of men and mills are excellent.

KEELING & CO., manufacturers of lumber, lath and shingles, Warren, Ont.: "In 12 years we have spent \$12.00 in subscriptions for the CANADA LUMBERMAN, and we have no hesitation in writing 'value received.' What interests us most in the Weekly Edition is the first page, 'Wanted and For Sale'—we read that first—then 'Current Trade Conditions,' and if there was a column as in the monthly edition, 'The News,' we would look over that next.

MCLAURIN BROTHERS, lumber, Montreal, Que.: There is always more or less news in your paper that is interesting to us. We hope some day to see your paper three times its present size. Wishing you every success.

G. B. HOUSSE LUMBER COMPANY, LIMITED, dealers in all kinds of rough and dressed lumber, Portage la Prairie, Man.: We have found your paper of interest in many respects.

N. D. SEAMAN & SONS, manufacturers of and dealers in lumber, lath, shingles, etc., Sauble Falls, Ont.: In looking over the years I have been a subscriber to the CANADA LUMBERMAN I consider it to be one of the best lumber journals in America (if not the very best),

always abreast of the times; everything new and useful to the woodworking interest can be found within its cover. I believe it should be in the hands of every lumber manufacturer in the Dominion, and do not miss an opportunity to recommend it to my co-occupationists.

GEO. CORMACK, wholesale lumber merchant, Whitby, Can.: I desire, as an old subscriber, to express the high appreciation and satisfaction I entertain in perusing the weekly and monthly contents, esteeming it as a publication of great merit, combining all up-to-date quotations from the various markets with useful and timely information in the best interests of the particular industries represented. Would not be without its counsel which I find very valuable indeed, and wish you every success and prosperity, with an increasing circulation.

J. H. EYER, wholesale lumber merchant, Toronto, Ont.: Your journal is a very welcome visitor to my office. I always consider your views on the market prospects to be good, and in fact to my view the chief value of your journal lies in these editorials.

JAMES YOUNG, manufacturer of and dealer in butter tubs, apple barrels, staves, heading, sash, doors, blinds, etc., Auburn, Ont.: I have been generally fairly well pleased with the conduct of the LUMBERMAN and your weekly articles "Current-Trade Conditions" have been read with interest.

A. KRAUSE, manufacturer of lumber, lath, shingles, etc., Williamsford, Ont.: The CANADA LUMBERMAN has been of great value to me in my business and it has also greatly improved during the last 10 years.

A. BARNET, lumber merchant, Renfrew, Ont.: I have always found your publication a very good source of valuable information in all things connected with the lumbering trade, since I commenced taking it some years ago.

J. B. FRASER, (of Fraser & Co.), lumber manufacturers, Ottawa, Ont.: I have been a subscriber to THE CANADA LUMBERMAN for a great many years, and have found it of very great interest and value to us in our business. I could not offer any suggestion for its improvement. It seems to me thoroughly up-to-date both in respect to reading matter and illustrations, and I much prefer it to any of the English or American publications of a similar kind.

L. F. LILLICRAP, The Lillicrap, Tate Lumber Company, manufacturers and dealers in lumber, lath, shingles and wood, Lakefield, Ont.: I am pleased to be a subscriber to your paper after ten years trial, and would say that I very much appreciate your efforts, I must say success, in providing the lumber trade with an up-to-date publication. With best wishes for the success of your journal and trusting that I will be one of your numerous subscribers ten years hence.

SCHULTZ BROS. COMPANY LIMITED, manufacturers of packing cases, frames, sash, doors, blinds, mouldings, etc., Brantford, Ont.: The CANADA LUMBERMAN has been coming to our office for a great many years and we have no intention at the present time of cancelling our subscription.

EMILE DUBE, Riviere-du-Loup, Station, Que.: I have much pleasure in stating that I have always found the CANADA LUMBERMAN a valuable help to my trade. I have been a subscriber for many years and I would not be without it. It is a well informed and a well edited paper and can be compared with advantage with any foreign review published in the interest of the lumberman. Wishing you continued success and progress.

A. MCPHENSON & Co., manufacturers of lumber and shingles, Longford Mills, Ont.: There has been a great improvement in your publication the last ten years and each week we look forward to receiving THE LUMBERMAN AND WOOD-WORKER. After reading we give them to the foreman or others as we often find

Some good pointer which we and they may take advantage of. Wishing you all success and prosperity.

THE M. BRENNEN & SONS MFG. CO., LIMITED, wholesale lumber, lath and shingles, Hamilton, Ont.: The CANADA LUMBERMAN has helped us to keep in touch with the market and the lumber trade in general, and its arrival always means a few hours of useful pleasure.

STANDARD OIL COMPANY OF NEW YORK, manufacturers of box shooks, Oswego, N. Y.: Our continued interest in your publication is based upon the fact that your paper is not too large to permit examination in the time which may be reasonably devoted to office literature; it speaks upon the special subject to which it is devoted and nothing else. The best of all, it has seemed to give concisely and briefly the market conditions uninfluenced by the wishes or interests of either the buyer or the seller.

LARD BROS., wholesale and retail dealers in lumber, lath, shingles, doors, sash, etc., Dresden, Ont.: Relative to the merits of your journal, would say that we have been a continuous subscriber for a great many years, and consider the money well spent, having found therein many items of interest to lumber dealers (whose industry you represent) and we are pleased to have an opportunity to express our appreciation of your journal which is invaluable to lumbermen or any person connected with the lumber industry.

HERMAN NOSS & SONS, manufacturers and wholesale and retail dealers in lumber and mill work, York, Pa.: The CANADA LUMBERMAN is a welcome visitor to our office and cannot see how we could do without it. It's up-to-date in every respect and should be in every office.

WILSON BROS., LIMITED, wholesale and retail manufacturers of doors, sash, wood turnings, interior finish, hardwood and pine flooring, etc., Collingwood, Ont.: You will no doubt be pleased to learn that we place THE LUMBERMAN ahead of any other trade publication we get, and we get quite a number, both Canadian and from across the line. We have been subscribers ever since we started in business and at no time has it ever occurred to us to discontinue. Your summary of the Current Trade Conditions has been of value to us time and again in our purchases and sales, and while we have not found it infallible, we consider it the best authority available on the lumber situation. We consider the "Wood-Worker" department a good one and would like to see it developed.

WM. LITTLE, Westmount, Que.: I take the greatest pleasure in saying that I have the highest opinion of the merits of the CANADA LUMBERMAN as a trade paper. In every respect it appears to me to be an admirable publication. Its weekly issues giving the price lists of all important lumber markets must be of great value to all those engaged in manufacturing, while the monthly issue always contains matter of interest and value to all lumbermen, and being well printed on good paper and of convenient size, and all supplied for the moderate price of one dollar a year, I cannot see wherein it can be improved. A complete file of the CANADA LUMBERMAN will be found to contain a fair account of all important matters relating to the Canadian lumber industry for the past quarter of a century, during all of which time it has been to me a most welcome visitor. With best wishes for the continued prosperity of the CANADA LUMBERMAN.

Beech as a hardwood flooring is coming to the front rapidly, and inasmuch as the supply of beech in the Southern States appears to be more plentiful than the supply of plain maple in the north, it is beginning to look like it will quite extensively replace maple. High-grade beech flooring is selling for practically the same price as maple right along, and it is claimed that in some respects it is a superior wood. However this may be, the fact remains that beech flooring is coming to the front, and in so doing has materially increased the market value of good beech lumber.



COLLINGWOOD DECEMBER 8TH.

The first concatenation to be held under the auspices of the new Vicegerent for Eastern Canada, Bro. J. G. Cane, of Toronto, will take place at Collingwood on Friday, December 8th. Bro. Cane's appointment was made by the Supreme Nine as the result of strong recommendations received from numerous members of the district, and it is safe to predict that they will be on hand to assist him in making his first concatenation a record-breaker. Members are promised something unique.

Bro. E. J. Ryan, backed up by a corps of active locals, will extend the hand of hospitality to all visitors. To those who know not Collingwood, it may be mentioned that located there is the modern mill of the Charlton Sawmill



BRO. J. G. CANE,
Vicegerent Snark for Eastern Canada.

Company, which has made more than one record.

As to the concatenation, from the first stroke of the gavel to the conclusion of the session "on the roof," lively times are promised. How many kittens will venture to penetrate the darkness is not yet known, but a fair-sized class seems to be in prospect. Every Hoo-Hoo member within a radius of two hundred miles is expected to answer the roll call, so arrange your plans to be in Collingwood on December 8th. Absentees will be subjected to a fine or nine cents, payable upon demand of the Scribe-noter.

14080.

AN AMERICAN VIEW.

Lower freight rates from the Coast into Canada means more American lumber in that country, temporarily at least. In time, however, the Canadian will insist on reciprocity or protection and will secure one of them.—West Coast and Puget Sound Lumberman.

—The Standard Lumber Company have just installed an electric light plant in their saw mill at Cranbrook, B. C. They also propose to employ a traction engine for logging operations, believing that they can effect a considerable saving by so doing.

THE Canada Lumberman AND WOOD-WORKER

Monthly and Weekly Editions—One Dollar Per Year.)

PUBLISHED BY

The C. H. Mortimer Publishing Company
of Toronto, Limited,

CONFEDERATION LIFE BUILDING, TORONTO.

BRANCH OFFICES:

38 ALLIANCE BUILDING, MONTREAL.

720-721 UNION BANK BUILDING, WINNIPEG.

Telephone 1274

22 GREAT ST. HELENS, LONDON, E. C.

536 HASTINGS STREET, SUITE 3, VANCOUVER, B. C.

Telephone 1943

The LUMBERMAN Weekly Edition is published every Wednesday,
and the Monthly Edition on the 1st day of every month.

TERMS OF SUBSCRIPTION:

One Copy, Weekly and Monthly, One year, in advance, \$1.00
One Copy, Weekly and Monthly, Six Months, in advance, 50
Foreign Subscription, \$2.00 a Year

ADVERTISING RATES ON APPLICATION.

THE CANADA LUMBERMAN AND WOOD-WORKER is published in the interest of and reaches regularly persons engaged in every part of Canada in the lumber, wood-working and allied industries. It aims at giving full and timely information on all subjects touching these interests, and invites free discussion by its readers.

Special care is taken to secure for publication in the WEEKLY LUMBERMAN the latest and most trustworthy market quotations throughout the world, so as to afford to the trade at home and abroad information on which it can rely in its operations.

Advertisers will receive careful attention and liberal treatment. For manufacturing and supply firms wishing to bring their goods to the attention of owners and operators of saw and planing mills, wood-working factories, pulp mills, etc., the CANADA LUMBERMAN AND WOOD-WORKER is undoubtedly the most direct and profitable advertising medium. Special attention is directed to "WANTED" and "FOR SALE" advertisements, which are inserted in a conspicuous position on front page of the Weekly Edition.

BRITISH COLUMBIA LOGGING LAWS.

The uncertainty regarding the legal status of the timber laws of British Columbia continues to be the subject of discussion, and during the past month developments of rather an interesting character have occurred. On the ground that Mr. J. S. Emerson intended to export a boom of logs in contravention of the law prohibiting such export, Government officials seized his tugs, logging equipment and logs, the purpose of such action being that the legality of the law prohibiting the export of timber might be tested. Mr. Emerson immediately took legal action to compel the release of the logs on the ground that the act did not apply to logs cut under a hand-logger's license and also that the Government could produce no evidence that the logs were to be exported.

Judge Henderson decided against Mr. Emerson on the main issue, but at the same time allowed him to come out of the legal fight virtually the victor. He held that the act legally applied to logs cut under a hand-logger's license, but that there was no right justifying a seizure or forfeiture on a mere declaration that Mr. Emerson intended to export the logs without first manufacturing them into lumber. It is altogether probable that the Government will appeal against the decision in respect to seizure, while Mr. Emerson is believed to be in favor of testing the export law in the higher courts.

The clause under which the Government seized the logs reads as follows: "All timber cut from Provincial lands must be manufactured within the confines of the province of British Columbia, otherwise the timber so cut may be seized and forfeited to the Crown and the lease cancelled." As the result of the claim that this clause applied only to timber cut under leases and permitted the export of all other timber, the Government in 1903 passed an order-in-Council providing that

timber cut under special license should also be manufactured in the province. It was no doubt the original intention of the Government to prohibit entirely the export of timber from the province, as is done in Ontario, but the wording of the act left room for doubt as to its application, and the order-in-Council was accordingly adopted. This left only the rights of the hand-logger to be determined and the controversy which has now been commenced between the Government and Mr. Emerson will likely bring about a decision in this respect which will finally dispose of the points in dispute which have unsettled the logging industry of British Columbia for some time past.

Sympathy for Mr. Emerson is not lacking, as it is felt that the timber laws of British Columbia have been rendered somewhat vague by the numerous amendments that have been made thereto.

CANADA'S TRADE WITH AUSTRALIA.

A special report has been made to the Department of Trade and Commerce, Ottawa, dealing with the possibilities of the Australian market for British Columbia lumber. While Washington and Oregon lumbermen are keenly exploiting that market, we are told that British Columbia manufacturers are making little effort and do not enjoy even a fair proportion of the Australian trade. The report urges that the lumber exported to that market be carefully manufactured and graded, under which conditions it should compete successfully with the United States product.

In this connection we wish to refer to the excellent work which was done by Mr. J. S. Larke, Canadian Commercial Agent in Australia, during his recent visit to Canada. Mr. Larke told the business people of this country some very plain facts, among these that the annual imports into Australia are about \$250,000,000 in value. Canadians, in Mr. Larke's opinion, should supply a much larger proportion of this trade, as the Australians are imperialists and with all other conditions equal would prefer trading within the empire. A preferential tariff, better transportation facilities and export houses with capital, are given as the three essentials in the development of trade between this country and the Antipodes. Many of the statesmen in Australia are in favor of a preferential tariff, and Mr. Larke believes that a preferential arrangement could be arranged.

Mr. Larke says that transportation is the key of foreign business and urges the Canadian manufacturers to work together with the object of securing low freight rates from the railways on export shipments, also a monthly steamship service between Eastern Canada and Australia. It is of no value to the Australian to know that the Canadian manufacturer produces goods cheaper than his foreign competitors if this is more than counterbalanced by the disparity in freight rates. Not one-tenth of the Canadian exports to Australia go by way of Vancouver, the bulk being through New York and Liverpool, which makes a tremendous difference in freights.

Mr. Larke's advice that Canada cannot do business in Australia by postage stamp is to the point. Our manufacturers should first advertise their goods, and follow this up, where the business is large enough to warrant it, by sending their own expert agent to represent them. When this is not feasible, several manufacturers in kindred but not competitive lines, should join together and send out an agent to represent them. Business has been lost in the past by carelessness in the manufacture and packing of goods, and he points out that special pains should be taken in packing goods for a water voyage of several thousand miles.

LUMBER TRADE EXPANSION.

The lumber industry of Canada is being developed upon most satisfactory lines. Thanks to the foresight of the Provincial Governments in prohibiting the export of the raw forest product to the United States, our manufacturing capacity has increased perhaps 50 per cent. within the last ten years. During this period one feature has been strikingly apparent, namely, the large number of United States manufacturers who have transferred their base of operations to this country. Not only have they invested extensively in timber limits, but they have established large saw mills and wood-working plants and are applying those thorough business methods which make lumbermen more than mere "hewers of wood" and by which every dollar is got out of the timber that it is capable of yielding. Many of the saw mills in Ontario are now owned and operated by former residents of the United States, while at the present time American capitalists are investing largely in British Columbia timber limits. These investments, it is satisfactory to know, are not being made from a speculative standpoint, but with the intention of securing the raw material for saw-milling establishments.

While we welcome American capitalists to this country under such conditions, we believe that Canadians are missing golden opportunities and permitting Americans to outdo them in securing possession of our valuable forests. Being accustomed to a plentiful supply of timber, we may not appreciate its value to the same extent as our cousins across the line, many of whom have witnessed the exhaustion of the timber supply of their district and the consequent extinction of the saw-milling industry.

A bulletin issued by the forestry division of the Department of Agriculture says the amount of wood annually consumed in the United States for packing boxes and baskets can not be given in exact figures, but it is much greater than is generally realized. The state of Michigan alone has forty-eight box-making establishments with an annual product valued at \$2,272,621. Other states have a yet larger output. There is hardly a business in the whole country which would not be unfavorably affected by a serious shortage in packing-box material.

COOPERAGE STOCK TOPICS

COOPERAGE STOCK MANUFACTURERS TO ORGANIZE.

A meeting of the manufacturers of cooperage stock was held in Toronto on October 31st, for the purpose of discussing trade conditions and to endeavor to devise some practical plan to increase the consumption of barrels and to manufacture cooperage stock at prices that would induce the consumers to use barrels. The following manufacturers were present: — James Innes, Sutherland - Innes Company, Chatham; W. H. Matthews, Trenton; John Cooper, Tupperville; F. H. Lawrence, Watford; W. B. Cargill, Cargill; Neil Watson, Mayor of Mull, Ont.; J. R. Reaume, Essex;



MR. F. H. LAWRENCE,
Who has been Appointed to Organize the Cooperage Stock
Manufacturers.

J. P. McAllister, Guelph; R. M. Pincombe, Strathroy; W. A. Burt, Toronto; G. S. Zimmerman, Tavistock; John Anderson, Wallaceburg, and J. C. Sheppard, Tilsonburg. Letters from a number of others expressed sympathy with the project.

It appears that the tendency of the past few years has been in the direction of using other packages than barrels for sugar, flour, apples and other commodities. Owing to the scarcity of elm timber, and the improved demand for hardwood lumber generally, there has been keen competition in the buying of timber by the different manufacturers, the result of which has been to increase the price of cooperage stock considerably, and consequently the price of barrels also. The manufacturers hope, by agreeing upon a uniform price to be paid for timber, to be able to sell their cooperage stock at more reasonable prices and also to prevent the wide fluctuations which have sometimes taken place.

The plan under consideration is the incorporation of a joint stock company, with a capital of, probably \$100,000, to which each manufacturer will subscribe according to the capacity of his mills. It is believed that such an agency would effect a considerable

saving in the cost of marketing the production of the different mills. The control of the output is another question which will likely be considered by the proposed organization. The headquarters of the company will be in Toronto.

THE MANUFACTURE OF HOOPS.

Since elm timber has become scarce and the first quality high in price, manufactures of hoops are facing a serious problem. It is generally conceded that hoops, as well as other cooperage stock, should be sold at a reasonable price, and manufacturers interested in the permanent trade desire to keep the values consistent with that of staves and heading, especially since the wire hoops have made such serious encroachments of late years. Good elm lumber commands a fair price, and the veneer concerns of the north are using a great deal of the elm timber, for which they often pay fancy figures. With the exception of a few manufacturers in Michigan, there are no concerns holding large quantities of elm timber or timbered lands, and it is commonly admitted that small factories, temporarily located where tracts of elm timber can be found, are better propositions than more permanent institutions.

Starting with the purchasing and cutting of timber, there are many opportunities for mistakes and losses before the manufactured hoop is loaded into the car. In the first place, timber must be bought in the right quality. Though some trees show green leaves and are apparently in good condition, many are, at the same time, so old that they are not a profitable investment for hoop timber. Dry rot has set in, and especially near the heart, the wood is a total waste.

Second-growth hard elm generally makes a very poor hoop. In the saw mill such timber cannot be separated into stave bolts and hoop plank, as can many logs having common defects, but the entire piece is often unfit for hoops and had better be left in the woods.

Many manufacturers make a mistake by letting timber stand too long. Recently there was a discussion among some manufacturers relative to dead timber, one claiming that it could not be coiled, but the fact is that hoops made from logs that have practically lost their life can, in many cases, be coiled, and we have seen such hoops put on the yard, apparently sound, but break afterward in the coil while being seasoned. For this reason inspection of the coils of hoops when the stock is being loaded is very essential, as defects of this kind are apt to be overlooked by the inspector behind the coilers.

Proper sawing of the plank is necessary to get out the timber to the best advantage, and a great waste caused by uneven plank is often noticed. For instance, it will run from $1\frac{3}{8}$ inches to $1\frac{1}{2}$ inches instead of being sawed just right and kept within $\frac{1}{16}$ of an inch of the

proper thickness. A variation of more than this amount is not necessary if the saw mill is a good one and the operators are experienced.

As in staves, many of the defects in hoops can be traced to improper steaming or boiling. There has been much discussion as to whether boiling or steaming the plank is the most advantageous. Either process will bring good results if properly carried out, but the most essential feature is to have the plank thoroughly cooked and the knife sharp. Otherwise, the timber will be shattered and, of course, will not work or coil with as low a per cent. of breakage.

The proper planing and lapping of a hoop determines its general appearance and is a part of the manufacture often given too little attention. The bits should be kept very sharp and ground many times, even though it costs a little more to supply the new ones. Recently we have noticed some hoops which were defective on account of not having a thin lap, or in some cases none at all. We have known keg hoops to break in the coil and in tressing because they were lapped over each other in the coil, a dent in the hoop resulting from its contact with the blunt end of the hoop next to it which should have been lapped to a thin edge. Even if damage on this account is not common, coopers prefer a hoop that is properly lapped and it costs little more to keep the saws in their proper position and in condition to do good work, both at the point and the lap of the hoop.

In coiling stock it is often noticed that mill men permit the coilers to use a stick or an iron bar across the boiling vat and to take out a large bundle of hoops with a hook, allowing them to rest on the support while being coiled. This plan is not a bad one provided a few hoops at a time are taken out of the water. If a trial is made you will be surprised to see how much the breakage increases where coilers are allowed to cool their hoops in this manner in order to work them easily.

Many manufacturers have boys to inspect the coils before loading on the wagons or trolleys, and the work is done in a very careless manner. The position is really a very important one, and should not be held by an incompetent person. The short hoops, as well as the long hoops, should be gone over carefully, and if every hoop that shows a defect is removed enough will be left in that cannot be seen or that will develop in seasoning to cover the 2 or 3 per cent. allowed for breakage and loss. We have noticed at some plants that enough help is not employed to properly cull the hoops at the coilers during a run on particularly bad timber, possibly while working up some logs that had lain too long and when the breakage was excessive for a short time in the mill. Assistance should be given the regular coiler in such cases or the hoops piled to one side to be worked over at odd times.

Hoops, to be properly piled on the yard, should be put on platforms not less than one foot above the ground to keep them away from the excessive moisture of the earth and grass and to more easily allow circulation. When properly seasoned, they should be taken in under cover and not allowed to remain exposed to rains and sun until they are over-seasoned, often becoming brash as well as discolored. — W. C. Hartman, in Southern Lumberman.

WESTERN CANADA

Western Offices of The Canada Lumberman,
720-721 Union Bank Building, WINNIPEG, MAN.; 536 Hastings Street, VANCOUVER, B. C.

THE CROW'S NEST PASS LUMBER COMPANY.

The saw-milling plant at Wardner, B. C., owned and operated by the Crow's Nest Pass Lumber Company, Limited, is the largest plant of its kind in the interior of British Columbia.

The saw mill equipment is composed of a double mill, and consists of two double cutting band mills of the latest improved patterns and

central point, where it is dumped into the large double conveyor chain, which carries its load of one cord every five minutes to the burner.

To the casual observer, it seems a pity that so much excellent fuel must be destroyed, when such extensive territory lies only a few miles to the east, where the fuel question is of so great importance. The reason for not shipping this fuel to the Territories is given by the

rolls into the slasher chains, where it is carried through six large slasher saws and cut up into four foot lengths. It is then dumped into the lath mill conveyor, where the lath stock is picked out, after which the waste is conveyed to the burner.

The filing and saw fitting room is especially worthy of notice. Here three large automatic grinders are continually at work; two of these handle the large double cutting band saws, and



MR. PETER LUND, GENERAL MANAGER.



GENERAL VIEW OF SAW MILL AND LUMBER YARD, CROW'S NEST PASS LUMBER COMPANY.

one large 96" (double) diamond gang edger, which handles the output from both band saws and takes cants up to eight inches in thickness. This machine is a little saw mill in itself, and contributes largely towards the output of the plant.

The mill is equipped throughout with every automatic appliance known to the saw-milling industry. The great automatic conveyors, travelling through the plant, pick up every particle of refuse, and convey the same to one

manager that no cars are available for that purpose during the running season of the mill, and that this product will not stand re-handling.

The large automatic trimmers are a source of great interest to the spectator, where ten saws appear and disappear automatically to trim off the ends, and any defect contained in the material passing over the same. All heavy refuse, such as slabs, edgings, culls, etc., are dropped automatically from the live

one all the circular saws, which in this plant are of great number and variety. The band saws are made in this department from plain steel plate. The workmanship on these saws is of marked excellence, and is being done under the supervision and master hand of Mr. W. C. Lichti.

The power plant consists of a battery of four immense boilers. This great steam plant consumes the sawdust from both mills, the same being distributed automatically into the great



OFFICE AND STAFF.



THE BIG MILL, CAPACITY 150,000 FEET PER DAY.

ovens as it is required. In the engine room, two immense twin engines are running so quietly and smoothly that a person must actually see them in order to know that they are running. The main drive belt in this mill is 48 inches wide, 140 feet in length, of double leather, and endless.

The entire saw milling department is superintended by Mr. H. C. Lindsay. Mr. Lindsay has had thirty-five years of experience in the saw milling business, and has had charge of some of the largest mills in the United States. He has been connected with the Crow's Nest Pass Lumber Company since its inception, and is very proud of his plant and his work.

The planing mills of the Company are super-

ing and scaling lumber. The loading facilities are such that fifteen cars can be loaded at one time, and dropped by gravity into the railway yards.

The Company's lumber yards are located and arranged so that the lumber can be handled with the greatest ease. The ground comprising the lumber yard consists of about forty acres, which slopes gradually to the south and towards the loading platform, thus making the drying and seasoning of lumber accomplished very conveniently.

The Company's water supply is obtained from a mountain stream about two miles from the mill, where a dam has been constructed and a six-inch main laid to the mill site and

consists chiefly of larch, cedar, spruce and yellow pine.

Logging operations are now carried on extensively. The field of operations is divided into two districts: The St. Marys river district is in charge of Mr. Edward Feagan. Two large camps, equipped for one hundred men each, are now in full swing, together with a number of jobbers and smaller camps. Ten million feet of logs will be driven out of the St. Marys river this season, including 100,000 railroad ties.

The Kootenay river district is in charge of Mr. David Breckenridge, who is operating two large camps in the Skookumchuck district, where about two hundred and fifty men



LOG POND AND PARTIAL VIEW OF JACK LADDER.



ALLEY NO. 68, IN THE LUMBER YARD.

intended by Mr. Otto Wisner. Mr. Wisner, as Mr. Lindsay, has had wide experience in his line. This department has a separate power plant, which furnishes steam for the two immense dry kilns, from which 50,000 feet of kiln-dried lumber is being discharged daily. The entire output of flooring, ceiling and siding is put into this kiln direct from the saws, and is dried, manufactured, and in No. 1 shipping condition forty-eight hours after having been taken from the mill pond. The planing mill is equipped with every up-to-date appliance and is operated night and day. One of the most complete electric light plants in British Columbia has been installed, and is operated from this department. Every part of the company's premises is lighted—the yards and mills by arc lights, and the buildings, from cellar to hay mow, by incandescent lamps.

The shipping platform is in charge of Mr. W.J. Montgomery. The system in vogue in this department is second to none in Canada. Mr. Montgomery has had wide experience in grad-

distributed through the lumber yard, mills, and all other buildings. This assures at all times a full supply of pure water for all purposes.

The mill pond has been taken out of the Kootenay river through a channel running behind an island, which has been improved by the construction of a dam at the outlet of this channel, at a cost of \$12,000. Forty large piers have also been constructed for booming purposes in the Kootenay river. The capacity of the mill pond proper is about six million feet of logs. A storage boom has been constructed about six miles above Wardner in the Kootenay river, for the purpose of holding the entire drive, which is expected to reach thirty million feet of logs in the spring of 1906.

The Company's timber supply is exclusively from the Kootenay river and tributaries. Over one hundred thousand acres of timber is controlled by the company, the most of which is of excellent quality, and is estimated to supply the mill to its full capacity for forty years. It

will be employed throughout the season, together with a number of smaller camps and jobbers.

Messrs. Carlin & Doyle, of Fort Steele, have a large camp located on Sheep Creek, about forty miles north of Fort Steele, where fifty men are employed. About three million feet of logs will be supplied from this source.

About one hundred men will be employed in the spring for the purpose of driving these logs to the mill. The Company have now under consideration the construction of a large steamboat for the purpose of transporting supplies and men to their logging camps on the Upper Kootenay river.

The offices and accounting departments are located on the side hill, overlooking the entire works; they are modern in construction, roomy and well lighted, and impress the visitor at once with the fact that behind this gigantic enterprise there exists a governing force and energy, possessed of all the necessary business training, with full knowledge of the



THE SORTING PLATFORM



VIEW OF DRY KILN.

importance of discipline, system and tact, as well as a sense of fairness, without which no great institution can continue, or be maintained.

Mr. Peter Lund, the managing director, secretary and treasurer, and the founder of this concern, is forty-two years of age. He was born in Christianstad, Sweden, emigrated



VIEW OF FILING ROOM.

to the Red River Valley at the age of nine years, and has since been closely in touch with the Canadian West. He is possessed of great business courage and force, and has unlimited confidence in the future of his adopted country.

Mr. T. G. Jones is the accountant of the Company, and is a man of superior qualifications in his line.

Mr. Harold Darling is the Company's paymaster, and keeps the accounts between the Company and its employees. He is courteous and gentlemanly in his dealings with all, and



W. BARCLAY, Shipper. W. T. MONTGOMERY, Yard Foreman.
H. C. LINDSAY, Mill Superintendent. O. WISNER, Planing Mill Foreman.

has the faculty of impressing the men with the fact that they are dealt with fairly. They always leave with kindly feeling towards the office.

Mr. A. Sheppard has charge of the shipping end of the office and attends to the greater part of the correspondence, and is possessed of exceptional ability in his line.

Mr. Lund, who is the power behind the

throne, is a partner in the firm of Breckenridge & Lund, railway contractors, who are extensively engaged in railway construction throughout Western Canada. Mr. Lund is also vice-president, secretary and treasurer in the Breckenridge & Lund Coal Company, Limited, whose mines are at Lundbreck, Alberta, where arrangements are now being made to supply a large portion of the rapidly increasing demand for domestic coal. Mr. Lund, with his partner, Mr. Breckenridge, is also interested largely in a number of retail lumber and fuel companies throughout the province of Alberta.

Mr. Lund was asked to explain the reason of the neatness of the premises, and the general harmony prevailing throughout, his answer being that he had the best lot of men in Canada.

The photographs reproduced herewith are by Mr. H. Penson, Amateur Photographer, Wardner, B. C.

LOADING LUMBER.

The North Star Lumber Company have installed an entirely new system for loading cars at their Cranbrook mill. A long platform has been built, extending from the edger saw out in the yard about five car lengths. On this has been erected a system of live transfer rolls which carry the lumber directly from the saws to the cars, where, by an automatic arrangement, the boards are raised off the live rolls which have been carrying them forward and, being brought in contact with a chain carrier running at right angles to the rolls, they are carried off the platform and dumped into the freight cars which have been hauled up alongside. By this method three men can do what it takes seven or eight men to do in the old way of yard delivery, one man being employed in oiling the rolls, keeping the running gear in order and releasing any congestion of the lumber that may occur in transit, while the other two men are engaged in directly handling the lumber as it is automatically dumped into the cars on which it is conveyed to the company's planing mill at Elko. The system is entirely new in British Columbia and was installed under the supervision of Mr. J. M. Sissosn. About 50,000 feet of lumber can be easily and conveniently loaded in one day by this method, it being possible, owing to the length of the system of rolls, to load five cars in succession without moving any.

FIGHTING FOREST FIRES IN BRITISH COLUMBIA.

Mr. Alex. McRae, forest ranger at Revelstoke, B.C., thus refers to the efforts of the Dominion Government to protect the timber lands in British Columbia: "My district covers from Beaver on the east to Sicamous on the west and from Arrowhead on the south to Carnes creek on the north. We employed from time to time over 100 men and fought over 58 fires. We got them all out before they caused very much damage but three which got beyond our control for a period of about a week, perhaps. We saved many millions of valuable timber, at a cost to the country of exactly

\$2128.25. The most of the fires occurred in the latter end of April, from clearing of the C.P.R. right of way, which as you know, is compulsory under the law. We have our system pretty well in hand now, however, and thanks to Mr. Kilpatrick's and local officials' help, instructions are now ordered for the immediate report of every fire seen in the district to my headquarters here. Thus we get at once on the ground, and you know, prevention is better than cure. The season is from May to October, but I think an effort will be made to make it begin earlier as a result of past experiences. J. Leamy, of New Westminster, is chief of the work in British Columbia and we work under the orders of Superintendent E. Stewart of Ottawa, who has developed the system, so happily instrumental in saving much to the country, into its present workable and creditable use and method."

REPAIRING A LOOSE PULLEY.

A correspondent of the American Machinist tells how he stopped the wobbling of a badly worn loose pulley in a wood-working plant. It ran on the main shaft and had been neglected for years. The shaft had been worn down 1/16-inch smaller than the original size, and very much out of the round. The section

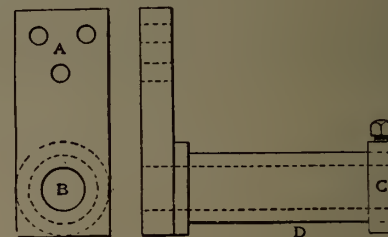

REPAIRING A LOOSE PULLEY.

of shaft could not be taken down for several reasons, mainly because it meant the shutting down of quite a number of machines. Having removed and rebored the pulley, a casting was made as per sketch. The three holes A were drilled clearance for 1-inch bolts. The bearing was then bolted to a faceplate and bored out at B 1/32 larger than the shaft, so it would readily slip on. The outside D was turned down to bearing size for the pulley. The pulley being slipped on, a collar C, with a setscrew, held it in place. The new bearing, with the pulley on, was then bolted in position to a joist. It has been running six months and is quite satisfactory.

AN OLD SAW MILL.

The oldest saw mill in the State of Oregon is thus described by the Pacific Lumber Trade Journal:

This saw mill is indeed a crude affair, constructed largely from poles and shakes. The power comes from a large water wheel—twelve feet in diameter. Attached to this is a belt of elk hide which operates an "up-and-down-saw" of ancient manufacture and a crude carriage. Throughout the country the Luderman mill, as it is known, is now regarded as a curiosity, though it has not been so many years since the people in that section took great pride in it as their greatest manufacturing industry. At one time it saved all the lumber used in building houses and bridges in that part of Oregon.

CANADA LUMBERMAN

AND WOOD-WORKER

WEEKLY EDITION

The Lumberman Monthly Edition 44 pages} \$1.00 PER YEAR {The Lumberman Weekly Edition every week.

THIS PAPER REACHES REGULARLY THE PRINCIPAL LUMBER MANUFACTURERS AND DEALERS THROUGHOUT CANADA, AND WHOLESALE BUYERS IN GREAT BRITAIN, THE UNITED STATES, AND OTHER FOREIGN MARKETS.

VOL. XIII

TORONTO, MONTREAL — NOVEMBER 29, 1905 — WINNIPEG, VANCOUVER

No. 38

CANADA LUMBERMAN

PUBLISHED BY

The G. H. Mortimer Publishing Co'y
of Toronto, Limited

Confederation Life Building - TORONTO.

Branch Offices:

38 ALLIANCE BUILDING, MONTREAL
720-721 UNION BANK BUILDING, WINNIPEG.
Telephone 1274.
536 HASTINGS ST., SUITE 3, VANCOUVER, B. C.
22 GREAT ST. HELEN'S, LONDON, E. C.

The Weekly Lumberman—Published every Wednesday, contains reliable and up-to-date reports of market conditions and tendencies in the principal manufacturing districts and leading domestic and foreign wholesale markets. A weekly medium of information and communication between Canadian timber and lumber manufacturers and exporters and the purchasers of timber products at home and abroad.

The Monthly Lumberman—A 44-page journal, discussing fully and impartially subjects pertinent to the lumber and wood-working industries.

WANTED AND FOR SALE

Advertisements will be inserted in this department at the rate of 15 cents per line each insertion. When four or more consecutive insertions are ordered a discount of 25 per cent. will be allowed. This notice shows the width of the line and is set in Nonpareil type; 12 lines make one inch. Advertisements must be received not later than 4 o'clock p. m. on Tuesday to insure insertion in the current week's issue.

FOR SALE—100,000 FT. HEMLOCK, TO BE cut to order. Address P. O. 6, Care "LUMBERMAN," Victoriaville, P. Q.

WANTED—TEN THOUSAND CORDS Hard and Soft Wood; also same quantity of Slabs. SIMCOE WOOD AND LUMBER CO., 52 Yonge Street Arcade, Toronto.

CEDAR FOR SALE—10,000 PCS. ROUND Cedar 8-16 and 25 feet long, at the Spanish boom. Also cedar, pine and spruce lumber for sale here at Larchwood. JAMES MCCREARY, Larchwood, Ont.

FOREMAN—MILLWRIGHT OPEN FORENGAGEMENT, A 1 references, 15 years experience in saw mill construction, up-to-date methods. Address Box 327 CANADA LUMBERMAN, Toronto, Ont.

FOR SALE, A GOOD SAW MILL, CAN SAW from 15 to 25 thousand per day, with everything complete, nearly new. Apply to ROBERT STEWART, Vasey P. O., Ont.

FOR SALE—250 M. FEET 1", 1 1/4", 1 1/2", 2", 3", 4" Hard Maple first class stock, 2" Hard and Soft Elm, 3/4" 1" Basswood, Cherry, White Ash, Pine and Hemlock, on C. P. R., near Ingersoll. This season's cut. Write for quotations to W. F. GALLOWAY or W. PARTLO, Ingersoll, Ont.

WANTED

Canadian Lumbermen, Limit Holders and Mill Men to supply a steady demand for dry, wormy pine lumber; also short butt logs for immediate shipment to be cut by portable mills or otherwise, so that useless waste is not handled.

Worm holes, splits, shakes, knots and small amount rot not objected to. All to be cut into one inch lumber and about the following dimensions, in lengths of 8 to 16 feet and small per cent. shorter lengths, 4, 6, 8, 10, 12 inches wide and up.

We are open to contract with right parties for a steady supply of about a car load a week to start with.

Quote prices free on cars.
For further particulars apply

THE DAVID GILMOUR DOOR CO.,
579 Tonawanda St.,
Buffalo, N. Y.

BOOK-KEEPER WANTED—FOR LUMBER Office in County Town. Apply Box 328, CANADA LUMBERMAN, Toronto.

FOR SALE—REDBIRCH, HEWED SQUARE, 12 inch and up, 12 feet to 16 feet long. Apply Box 325, CANADA LUMBERMAN, Toronto.

WANTED.

LATHS WANTED FOR SHIPMENT BY car this winter. Either 1 1/2" or 1 3/4", standard Spruce. Butted 4 ft. Address C. S. WENTWORTH & CO., 147 Milk Street, Boston, Mass.

WANTED—A MAN WITH A GOOD PORTABLE mill to saw lumber in the county of Hastings during the winter and spring of 1906 and succeeding one or two seasons. Address Box 326 CANADA LUMBERMAN, Toronto, Ont.

LUMBER MANUFACTURERS AND DEALERS, sawmill engineers, etc. desiring advertising space in Canadian Section, Special Annual Issue, London (England). Timber Trades Journal, please write authorized agent, R. ST. J. YOCKNEY, 45 Gloucester Street, Ottawa.

FOR SALE—100,000 FEET DIMENSION Spruce Timber, to be delivered on first snow roads, viz. 6 x 6, 7 x 7, 8 x 8, 9 x 9, average in proportion about 5 zes. Lengths 18 to 32 feet. Address "LUMBERMAN," P. O. 6, Victoriaville, Que.

MILL PARTNERSHIP WANTED

EXPERIENCED MAN WITH CAPITAL wishes to acquire partnership in small saw mill in interior of B. C. on railway, might buy outright if satisfactory arrangements could be made. Address PARTNERSHIP, CANADA LUMBERMAN, Vancouver office.

FOR SALE AT A BARGAIN—NO. 3 HAMILTON Carriage Steam Feed, 7 1/2" cylinders and all connections, circular outfit complete with iron husk, mandril, etc. Two boilers 22 feet long, 4 feet in diameter, six boilers 20 feet long and 4 feet in diameter, two 14" flues in each. Full Second Hand Outfit for Circular Mill. THE ONTARIO LUMBER COMPANY, LIMITED, Toronto, Ont.

MACHINERY FOR SALE

We have for sale the following second hand machinery, in good condition. Write us for full particulars and prices of any machine.

- 1 26" x 32" engine box frame, slide valve on top of cylinder, driven with rock shaft.
 - 2 No. 3 single cutting band mills, made by Prescott Co.
 - 2 Two block carriages with Prescott offset, made by Prescott Co.
 - 1 Two block Garland carriage.
 - 1 Boss shingle machine, made by Mowry.
 - 1 Hall shingle machine.
 - 4 Perkins Grand Triumph shingle machines.
 - 3 Drake hand shingle machines.
 - 4 Perfection power shingle machines.
 - 1 Double block shingle machine, Perkins make.
 - 1 Drag saw.
 - 1 Knee boiler.
 - 1 Perkins Class A cut-off.
 - 2 Wheel jointers.
 - 2 Knot saw frames.
 - 7 Shingle packers.
 - 1 Heading trimmer.
 - 2 Rich automatic saw sharpeners.
 - 1 Independent condenser.
 - 1 Portable boiler and engine, boiler with 32" fire box, and 28-3" tubes, 12 h p., engine 8 x 12.
 - 1 Greenlee No. 1 improved automatic cut-off machine, with countershaft.
 - 1 Friction feed complete, frictions 15" wide.
 - 1 36" standard Lefel water wheel.
 - 1 Upright boiler 70" x 32" with sixty 2" tubes.
 - 1 " 54" x 32" with ninety 1 1/2" tubes.
 - 1 10" x 16" twin engine, steam feed, complete.
- THE WM. HAMILTON MFG. CO. LIMITED
Peterborough, Ont.

FOR SALE: ABOUT 3 CARS OF 3" AND 1 car 2" White Maple Winter cut. Address ANDREW KNOX, Box 22, Norwood, Ont.

WANTED—1" 6/4" AND 2" BLACK ASH, 6/4" and 2" Basswood, all common and better, dry. Box 326, CANADA LUMBERMAN, Toronto.

WANTED—PRIME 1S & 2S ROCK ELM Planks, 2 1/2" and 3" thick by 5" and up wide by 12' to 16' long. JAMES KENNEDY & CO., LIMITED, Cincinnati, Ohio.

HARDWOOD SALESMAN WANTED, WHO has good connection with the trade and thoroughly posted in grades, strictly temperate, Box 331 CANADA LUMBERMAN, Toronto.

WANTED—AN UP TO DATE INSPECTOR to buy and ship Pine and Hardwood Lumber from the Georgian Bay District. Address Box 332 CANADA LUMBERMAN, Toronto, Ont.

FOR SALE—A QUANTITY OF EACH OF the following: 1/4" Spruce, 1" Spruce, 1" Basswood, 1" Soft Maple, 1" Cedar, 1" Soft Elm. Apply Box 334 CANADA LUMBERMAN, Toronto, Ont.

AN UP-TO-DATE SAW MILL—NEWLY built this summer; capacity fifteen to twenty M per day; six miles from a new railway line James Bay Railway. For particulars apply to JOHN THOMPSON, McKellar P. O., Ont.

FOR SALE—75,000 FEET 1 IN. BIRCH, 25,000 feet 2 in. Birch. Entire product of logs cut and piled six months; best shipping conditions; snap for some one if shipped before December 31. Box 330 CANADA LUMBERMAN, Toronto, Ont.

WANTED BL'CK ASH

ONE INCH AND THICKER 1S & 2S AND No. 1 common; must be well manufactured and of good fair widths. BROWNLEE & CO., Detroit, Mich.

FOR SALE

THIRTY-FIVE HORSE PORTABLE ENGINE and boiler locomotive suitable for saw mill nearly new. Address Box 333 CANADA LUMBERMAN, Toronto.

SAW LOGS

WE ARE OPEN TO PURCHASE FIVE Million Feet of Pine, Spruce and Hemlock logs, 12 to 25 ft., in boom Arnprior, June or July delivery. OTTAWA LUMBER CO'Y, Ottawa, Canada.

LATH WANTED

32" LATH IN PINE, SPRUCE OR HEMLOCK. Must be well manufactured and good grade. State lowest price f.o.b. shipping point, giving rate and weight to Utica and New York. Utica Branch, RICE & LOCKWOOD LUMBER CO., Utica, N. Y.

FOR SALE

One second-hand Engine Lathe, 32 inch swing, 22 foot bed, with face plate and chuck combined, steady rest and counter shaft—to be sold cheap to replace with new tool.

Also one second-hand Tubular Boiler 3 feet diameter, 12 feet long. Apply

ST. JOHN IRON WORKS, Ltd.
P. O. Box 391. - Vulcan St., St. John.

FOR SALE

NEXT SEASON'S SCUT OF HEMLOCK, PINE, BIRCH and Maple Lumber, also orders taken for Veneers and Handles, will also saw one million feet of logs at price per M feet. Shipment by Rail or Vessel. Correspondence solicited T. H. DECEW & Co., Bruce Mines, Ont.

MILL PROPERTY FOR SALE

SAW MILL IN PROVINCE OF QUEBEC, capacity 50 M ft. per day, equipped with Side Edge Slab Saw Perkins Single Machine, best Feed Grinder, all in good condition. Also 33 acres of land as mill site. Timber enough for 20 years, fed from rivers, good crop of logs for next season. Reason for selling, going into other business. Address Box 329 CANADA LUMBERMAN, Toronto.

DON'T BUY PULPWOOD

until you have had my quotations. Best market prices on spruce and poplar pulpwood furnished on request.

GEO. F. WHALEN

PORT ARTHUR, ONT.

CURRENT TRADE CONDITIONS.

ONTARIO.

Reports from all sections of the country tell of a good pine and hemlock trade and but little falling off in the demand for building material. The month of November, however, experienced more than usual activity, and it is probable that the next two weeks will witness a curtailment consequent upon the approach of the winter season. In Toronto building is still active, which is sustaining the retail demand for lumber. The mills are moving stock by rail as rapidly as possible, but the inability of the railways to supply a sufficient number of cars is causing much inconvenience.

Prices of lumber are quite as firm as last week and promise to continue on a strong basis, as the aggregate quantity of pine and hemlock stock in first hands is very moderate. The hardwood trade is rather featureless. The recent discussion of the comparatively low price of basswood has, it is said, caused a little buying in some

quarters, but values show no inclination to advance. Lath are strong and the white pine variety very scarce. "It is impossible to find a firm who have a stock on hand" is the report which reaches us from Ottawa.

QUEBEC AND NEW BRUNSWICK.

More general strength characterizes the lumber market of the Eastern Provinces than at any previous time this year. Negotiations in connection with next year's business suggest the probability of shippers asking higher prices for waney pine timber, while there is also a disposition to hold birch timber for better prices. As the British market has now fallen into line, there is no weakness anywhere, and indications point to an all-round improvement in trade. There has been a sharp advance in freight rates from St. John by the winter steamers, as, owing to the better demand, shippers are anxious to send forward as many deals as possible. The spruce shipments from that port up to the end of October were 140,436,544 superficial feet, as compared with 152,738,255 feet in 1904. The birch shipments were 6,188,709 feet, as against 4,802,545 feet last year. There has been a good demand for birch planks at very satisfactory prices.

MANITOBA AND BRITISH COLUMBIA.

There is little falling off in the demand for lumber for building purposes and most of the mills have a considerable number of orders on their books. There is plenty of stock, however, to supply the requirements, and, statements to the contrary notwithstanding, no price changes are likely to be witnessed during the next few weeks. It may be that later on the mills will be compelled to advance their quotations owing to the high cost of logs. Fir logs are now selling in Vancouver at from \$7 to \$8.50, and as the supply is by no means plentiful, higher prices in the near future are predicted. It is under-

stood that the British Columbia Lumber & Shingle Manufacturers' Association are considering the advisability of closing down the shingle mills for two months simultaneously with the Puget Sound mills. This would enable the surplus product to be worked off.

UNITED STATES.

The lumber demand is still quite insistent and apparently there are plenty of people who are willing to buy lumber at present prices for other than immediate requirements. The condition of stocks is such as to remove any hope of lower prices during the winter months, while if the consumption should continue at the present enlarged volume, it is not unlikely that some classes of stock at least will be advanced before the spring. Nearly all the northern pine product has passed out of first hands, and still the railroads and car builders are in need of stock. There is hardly any limit to the price that can be obtained for spruce for prompt delivery, but the average price may be said to be \$26 for 10 and 12 inch dimension and \$24 for 9 inch and under, Boston delivery. Hemlock is strong, prices for piece stuff in the Saginaw Valley ranging from \$13 up, according to length. The hardwood situation is still somewhat unsatisfactory, but appears to be slowly mending. Wisconsin dealers report a good demand for maple, rock elm and birch, and basswood is doing better than earlier in the year, although that is not saying much.

A sharp advance in the price of red cedar shingles is predicted as the result of the expected shutting down of the Washington mills. The demand in the east is strong and stocks light. Clears are reported to be selling in Boston and Tonawanda at \$3.25 wholesale.

GREAT BRITAIN.

The improvement in the tone of the British market has been main-

tained and the outlook for business is much brighter than during the summer months. The market has apparently taken a turn for the better, the light stocks no doubt being an important influence in bringing about this change. The stock of pitch pine at Liverpool, for instance, is only 346,000 cubic feet, as against 815,000 cubic feet last year, while at Manchester it is only 178,000 cubic feet, as against 439,000 cubic feet last year. Shippers are asking from 67s. 6d. to 70s. per load as against 52s. paid last year. Spruce and whitewood are still on the rise and eagerly sought after. The shortage in these lumbers is also very marked and promises to be still more pronounced before new arrivals next year. For 3 x 11 inch unassorted spruce, £9 10s. per standard was recently realized at auction, the 3 x 9 inch bringing £9 5s., prices which are considered as very satisfactory. There is a splendid demand for birch planks at advancing prices, and the scarcity of sawn laths at the mills in Sweden has caused a sharp rise in the prices of these goods. Some shippers are asking 10½d. c.i.f. London.

No business for next year has been closed so far as can be learned. It is reported that some agents are asking an advance on this year's opening prices, while importers claim that the present retail prices will not permit them to give even as much as they did last winter.

STOCKS AND PRICES.

Buffalo jobbers quote first-class elm flour barrel staves at \$8.50 to \$9; basswood heading, 5½ to 5¾ cents, and coiled hoops, \$9.50 to \$10 for 6-foot.

Charles Hawkes, of Lower Cape, N.B., has taken the contract to cut the lumber on the Turner property at Germantown for William Mackay, of St. John, N.B.

The improvement in value of spruce deals in Great Britain is now reflected in hemlock. An advance of fully 15s. per standard has been recorded during the last two

months; £6c.i.f. for ordinary specification has been done, North-west Coast port.

The Sims Lumber Company, of Sault Ste. Marie, Ont., have contracted with Kerr Bros., of Calumet, Mich., for the delivery of 200,000 feet of pine logs during the winter.

There are fourteen inches of snow on the upper St. John river, in New Brunswick. One hundred million feet is the estimate of the cut. The average wages are about \$26 to \$28 per month.

The Port Renfrew Logging Company, which for the last couple of years has conducted logging operations at San Juan, west coast of Vancouver Island, B.C., have suspended work there and dismantled their camps, all the timber on the limits having been cut.

The lumber market at Boston, says the New York Lumber Trade Journal, has been moderately active during the first half of the month and throughout the list values are firmly held. The fine weather has been a great help to business. Spruce still causes the greatest comment, and it is almost impossible to make quotations to cover the market. Yards have very small stocks. Wholesalers have taken orders for delivery during February and later. For prompt shipment \$25 and \$27 are quoted, and in a few instances even higher prices have been paid. Spruce laths are in active demand. Even mill men have been in town looking for supplies. It is reported that one mill has asked as high as \$5 for 1½-inch by rail, but \$4.50 is the top price reported paid. A few sales of 1½-inch are reported as having been made at around \$4.50 for quick delivery. The hemlock situation is

W. C. CRAWFORD

Tilbury Ont.

Manufacturer of . . .

Handles—Axe, Fork, Pick, Etc.

Also Hard and Soft Wood Heading, and Red and White Oak, Maple and Elm Lumber.

Can supply Second Growth White or Red Oak squares up to 38 in. long in large quantities.

Planing and Matching

—IN TRANSIT—

S. POMEROY, Grillia

PLANING, MATCHING, RESAWING, SIDING, FLOORING, MOULDINGS in Car Lots.

Factory near Station. Write for Prices. Phone 113

KNIGHT BROTHERS CO. LIMITED
Burk's Falls, Ont.

KILN-DRIED BIRCH FLOORING

Send for Catalogue
and Samples by Mail

KNIGHT BROTHERS CO. LIMITED
Burk's Falls.

Keenan Bros., Limited
Owen Sound, Ont.

HARDWOOD, HEMLOCK AND PINE LUMBER

We carry a full supply of native Hardwoods always on hand and solicit your inquiries. At the present time we have piled at outside points about 2,000,000 feet of Hardwoods, and about the same quantity of Hardwood, Hemlock and Pine piled here in Owen Sound, and we should be able to interest you if in the market.

WILL MAKE SPECIAL PRICES ON
BROKEN LOTS AT OUTSIDE POINTS

MASON, GORDON & CO.
80 St. Francis Xavier Street - MONTREAL, QUE.

WHOLESALE LUMBER and TIMBER

Car and Cargo Lots Only

Specialty: Dimension Timber in DOUGLAS FIR, PINE, HEMLOCK, SPRUCE, YELLOW PINE or OAK.

Correspondence Solicited.

EVERYTHING IN LUMBER AND TIMBER
DRESSED AND IN THE ROUGH

THE M'LENNAN LUMBER CO., LIMITED

MONTREAL QUE.

Office and Yard, 571 DORCHESTER ST.

P.O. Box 116

BIRCH PLANKS.

Birch planks, says the Timber News of Liverpool, Eng., have gone the notch higher, a good line having been placed to London at £8 10s. c.i.f. for shipment from St. John promptly, we understand. Sales have been made to Liverpool, where freights generally are a shade lower, at £8 5s. c.i.f. for St. John shipment, with Halifax a shade lower than this price. Glasgow has not as yet responded to improved values. We are inclined to think that £8 10s., c.i.f., is the high-water mark, and that shippers and manufacturers will not be wise in trying to force c.i.f. values above this figure, which gives them a fair return, otherwise the impetus which high prices give to production may put supply above demand and cause the inevitable. Concessions for spring shipments will likely be made, but it is too early, with the data we at present have, to form an opinion, as much will depend on the winter and what quantity of logs can be got out and hauled to the mills.

We hear a good deal of no consumption. It will therefore be interesting to give and compare the

figures for the 10 months of this year with the two previous years for the port of Liverpool, as culled from the brokers' stock sheets. The figures given are: Consumption, 572,000 cub. ft. for this year, 289,000 cub. ft. for last year, and 487,500 cub. ft. for 1903, an increase of almost double the preceding year and 85,000 cub. ft. in excess of 1903—strange, but authentic. The indications, with the improved state of the tinplate trade (who are large consumers of hardwood for boxes) and of trade generally, are more favorable than at this period last year, and it is well to bear this in mind. Prices are 20s. higher than this period last year, which must also be kept in mind.

We hear of a sale of Quebec birch to London, small average, at an advance on last year's prices.

H. D. WIGGIN BOSTON, MASS.
89 STATE ST.

will inspect at mill and PAY CASH for

LOG RUN

Elm, Ash, Bass and other Hardwood
CORRESPONDENCE SOLICITED.

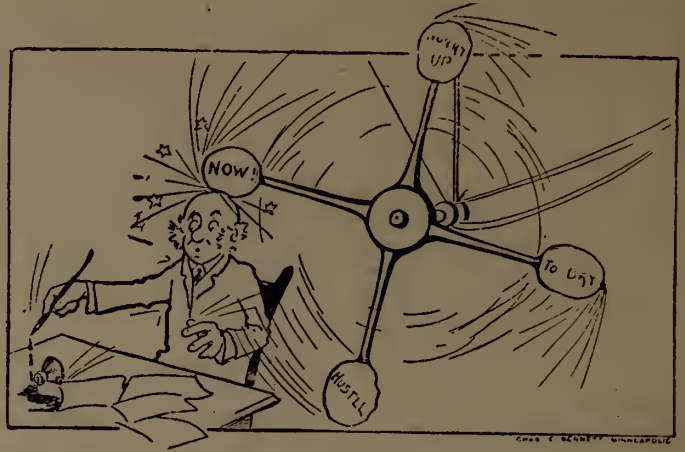

JUST A GENTLE REMINDER

That's all—a reminder that we can supply your wants in the lumber line.

It's up to you NOW to realize that fact and to open up correspondence with us.

Don't forget that SPRUCE LUMBER is our specialty—and should be yours. Let us tell you why.

The Red Deer Lumber Company
WINNIPEG, MAN.

R. H. ROYS, Pres.
RALPH LOVELAND, Vice-Pres.
C. A. KENT, Sec'y.
R. S. ABBOTT, Treas.

SAGINAW LUMBER & SALT CO.
MANUFACTURERS OF
LUMBER AND SALT

Mills at Sandwich, Ont.

SAGINAW, MICH.

UNITED STATES MANUFACTURERS AND WHOLESALERS

**YOU
CAN
REACH**

THE BONSAK LUMBER CO.
WHOLESALE HARDWOODS

ST. LOUIS
BY
RAIL, MAIL
WIRE OR
'PHONE

YELLOW PINE

We are in position to give first-class stock. Reasonable prices. Prompt shipments. Mills in Alabama, Mississippi and Arkansas.

MANN, WATSON & CO. Muskegon, Mich.

THE WICKS LUMBER COMPANY
BATTLE CREEK, - MICH.

We will pay cash for Hardwood Lumber; especially want

Black Ash and Rock Elm

J. F. QUIGLEY LUMBER & LAND CO.
GRAND RAPIDS, MICH.
HARDWOOD LUMBER

SEND TO US FOR QUOTATIONS

OFFICE:
106 Michigan Trust Building

GRAND RAPIDS, MICHIGAN

FRANK C. BURY

BURY & NOBLE

MASON A. NOBLE

WHOLESALE

LUMBER - DETROIT

MICHIGAN

Send us your inquiries for Southern Yellow Pine.

McGLURE LUMBER CO.

Wholesale Dealers in . . .

Hardwood Lumber

Carry in Stock and Have for Sale

ASH, BASSWOOD, BEECH, BIRCH, BUTTERNUT, CHERRY, CHESTNUT, COTTONWOOD, CYPRESS, ELM, GUM, HICKORY, MAHOGANY, MAPLE, OAK, POPLAR, SYCAMORE, WALNUT, POLES (Oak, Hickory and Ash), RIMS and SPOKES (Oak and Hickory), OAK BENDING PLANK, OAK BILL STUFF, RAILWAY TIES.

ROUGH YELLOW PINE TIMBERS and PLANK

Office and Yards: 520 to 530 Franklin St., DETROIT, MICH.
Mills: Eutaw, Ala.; McClure Station, Ala.

Correspondence Invited on All Hardwoods.

SAW AND PLANING MILL ANNUAL CAPACITY, 100,000,000 FEET.

THE DIXIE LUMBER CO.

WHOLESALE YELLOW PINE MANUFACTURERS
ST. LOUIS, MISSOURI.

Timbers, Rift Sawn Flooring and Finishing

Mills at LITTLE BAY, ARK., ALDEN BRIDGE, LA., ALLENTOWN, LA.

THE ROBERT H. JENKS LUMBER CO.
CLEVELAND, OHIO

MANUFACTURERS AND WHOLESALERS OF

YELLOW PINE, POPLAR, HEMLOCK AND HARDWOODS

Yellow Pine Timbers a Specialty

CANADIAN MANUFACTURERS and WHOLESALERS

THE PEMBROKE LUMBER CO.
PEMBROKE, ONT.

We make a specialty of Dimension Stock in Pine, Spruce and Hemlock, and solicit your enquiries.

ALBERT J. DELAPLANTE
WHOLESALE

Pine, Hemlock, Lath, Shingles, Etc.

Office: 503 Manning Chambers - - TORONTO

FOR Pine, Hemlock, or Hardwood, Lumber and Timber, Telegraph Poles, Ties, Posts, Lath, Shingles, Dressed Lumber, Sash, Doors, Interior Finish, End Matched and Bored Hardwood Flooring, etc., try

JOHN HARRISON & SONS COMPANY, LIMITED

We have a complete stock, two Saw Mills running in summer and one all winter. HEAD OFFICE. SAW AND PLANING MILLS, OWEN SOUND, ONT.

RHODES, CURRY & CO., Limited
LUMBER MERCHANTS.

Yards at Amherst, Little Forks, Sydney and Halifax. BUILDING MATERIAL of all kinds carried in stock. We are buyers of Ontario Basswood, Elm and Pine.

Amherst, N.S.

Sawn and Hewn pruce, Hemlock, Pine and Birch Timber, Spruce and Pine Boards and Plan, Birch and Ash Boards and Plank, Flooring, Shingles, etc.

JAMES J. MURPHY, Bank of Hochelaga Building **QUEBEC**

F. MCGIBBON & SONS, PENETANGUISHENE ONT.

Manufacturers of Pine, Hemlock and Hardwood Lumber, and dealers in Cordwood Hemlock Bills cut on short notice.

The Cook & Bros. MANUFACTURERS OF **Lumber Co.**

Of Ontario, Limited MILLS at SPRAGGE, Algoma Dist., Ont. on "Soo" Branch C. P. R.

OFFICES { Manning Arcade, Toronto
Cristine Building, Montreal
And at Mills at Spragge.

White and Red Pine Lumber and Lath

Water Shipments

THE M. BRENNEN & SONS MANUFACTURING CO., LIMITED

Saw Mills at RAINY LAKE, Ontario. Planing Mill and Head Office: HAMILTON, Ontario.

THE NIPISSING LUMBER COMPANY, LIMITED

Mills at CACHE BAY and SPANISH RIVER, Ontario.

Manufacturers of and Wholesale Dealers in all kinds of LUMBER AND LATH

Both Railway Delivery and Water Shipments. Correspondence Solicited. The NIPISSING LUMBER CO., Limited Head Office: HAMILTON ONT.

A. F. BURY AUSTIN
WHOLESALE LUMBER and TIMBER
CANADA PINE

Bank of Ottawa Building, 224 St. James St., - MONTREAL, CANADA

SPECIALTIES: Railway Bridge Timber and all kinds of Hardwoods; Ship Decking, Norway and White Pine, Dimension Timber, Norway Car Sills, Car Flooring, Telegraph Poles, Railway Ties, Oak and Whitewood, Planed and Rough Lumber, British Columbia Pine, Southern Pine, &c.; Birch Flooring, hollow back, end butted.

Eastern Agent for The Pacific Coast Lumber Company, Limited, Vancouver, B. C. Douglas Fir: Timber in any size or length up to 90 feet long. Timber Planers face up to 24 inch x 30 inch. Dry Kilns of large capacity. Rough and Dressed Lumber, Douglas Fir and Cedar.

WRITE FOR PARTICULARS AND QUOTATIONS.

R. LAIDLAW LUMBER CO.

JAS. PLAYFAIR.

D. I. WHITE.

PLAYFAIR & WHITE

Manufacturers and Wholesale Dealers

LUMBER • LATH • SHINGLES

Contractors for Railway Supplies
BILL TIMBER a Specialty

MIDLAND, ONT.

A. & P. WHIGE

Manufacturers of and Dealers in

Sawn and Planed Lumber, Dimension Timber. Joisting Car Sills, Car Flooring, Shingles and Lath.

PEMBROKE ONT.

MAITLAND, RIXON & CO. OWEN SOUND, ONTARIO.

Manufacturers and Dealers

LUMBER LATH, TIES, POLES, SHINGLES, ETC.

Make a Specialty of Long Pine, Cedar and Hemlock Bill Stuff. We ship by C. P. R., G. T. R., and by Water.

THE TURNER LUMBER COMPANY, LIMITED
TORONTO, ONT.

National Life Chambers,
25 Toronto Street (Tel. Main 6244)

Wholesale Lumber Manufacturers and Merchants

Lumber Manufactured at Midland, South River and Cutler.

HARDWOOD FLOORING

End Matched, Bored, Steel Polished, and Bundled

Send for Price List

A few cars of selected Maple and Birch and other Hardwoods at close price

THE SEAMAN KENT CO., Limited
160 Bay St. Toronto Factory, Meaford, Ont.

HARDWOOD FLOORING

MANUFACTURED IN

MAPLE, BIRCH, BEECH AND OAK

3/8, 5/8, 7/8, 1 1/8 and 1 3/8 inch thicknesses. Kiln-Dried, Hollow Backed, End Matched, Bored and Polished, bundled with wire baling. . . .

Also Stock fully machined for Spring Bed Frames

and

ALL KINDS OF HARDWOOD LUMBER

J. S. FINDLAY - OWEN SOUND, ONT.

A SPLENDID ROUTE.

The Wisconsin Central Railway is justly termed the "Sportman's Line" because it reaches into and through the very heart of the choicest hunting grounds in America.

The very best wild fowl shooting of the entire North is reached ONLY by this line. Hundreds of beautiful lakes abounding in wild rice and celery attracts myriads of ducks and geese and afford the finest kind of cover and the choicest shooting to be found the country over.

The Wisconsin Central Railway caters especially to the sporting public and during the various seasons for hunting and fishing furnishes daily information to its patrons as to local conditions anywhere along its lines upon application to the nearest ticket agent. It also arranges its train service with special reference to the convenience and comfort of sportsmen, and its employes are constantly on the alert to make travel over their lines pleasant and comfortable.

This line offers the best route between Chicago, St. Paul, Milwaukee, Minneapolis or to Lake Superior points via Ashland, Wisconsin.

Information given by addressing—

JAS. C. POND, Wis. Cent. R. R.
Milwaukee

ADVERTISE YOUR WANTS IN

Weekly Canada Lumberman

Toronto Montreal Winnipeg
Vancouver

AUGER & SON

We Buy, Sell and Deal in all kinds of Lumber and Timber in Canada and United States: Spruce, White Pine, White and Basswood, Ash, Cedar, Douglas Fir, Beech, Birch, Walnut, Cherry, Chestnut, Cottonwood, Hemlock, Maple, Norway Pine, Short and Long Leaf Yellow Pine, Oak, Redwood, Birch, Maple and Oak Floorings, Pulpwood, Ties and Cedar Poles

Quebec

Cedar Cove Mill,
Vancouver, B.C.

E. H. HEAPS & CO.,

Ruskin Mill,
Ruskin, B. C.

Vancouver, B. C.

Lumber, Lath, Shingles, Doors, Mouldings, Etc.

SPECIALTIES :

AA1 HIGH GRADE CEDAR SHINGLES.

Cedar Bevelled Siding, Cedar Door and Sash Stock, cut to size, Cedar Finish, Base, Casing, Newels
Balusters, etc. Douglas Fir Timber up to 85 feet in length.

<p>W. J. SHEPPARD PRESIDENT Waubausheene, Ont.</p>	<p>J. G. SCOTT, GENERAL MANAGER Vancouver, B.C.</p>	
<p>MANUFACTURERS OF</p>		
<p>FIR, CEDAR AND SPRUCE LUMBER LATH, MOULDINGS TURNED WORK ETC.</p>	<h1 style="font-size: 2em;">Pacific Coast Lumber Co., Limited</h1> <p>VANGOUVER, B.C.</p>	
		<p>HIGH GRADE RED CEDAR SHINGLES</p>
<p>Ontario Representative, W. J. LOVERING, 112 Mail Building, TORONTO</p>		

D. C. CAMERON, President and Manager.

WM. ROBERTSON, Secretary.

J. E. YOUNG, Cashier

The Rat Portage Lumber Co., Ltd.

Manufacturers
of

White and Red Pine Lumber, Lath, Shingles, Sash, Doors, Turned and Band Saw Work

Dealers in CEDAR POSTS, POLES and TAMARAC PILING

Mills at RAT PORTAGE and RAINY RIVER, Ontario WINNIPEG, Manitoba, and VANCOUVER, British Columbia. Head Office: RAT PORTAGE, Ontario
Our Vancouver Mill cuts High-Grade Cedar, Fir, Spruce and Red Cedar Shingles. Winnipeg Mills cut Pine, Tamarac and Spruce Lumber
We also Manufacture all kinds of Mouldings, Sash, Doors, Turned Work and Boxes. Correspondence solicited at all four points.

Export Lumber & Shingle Co., Limited

Vancouver, B. C.

We are Exclusive Selling Agents in Canada
for 40 per cent. of the Shingles manufac-
tured in British Columbia. Daily shipping
capacity over 1 1/4 millions.

W. C. WELLS

PALLISER, B. C.

Manufacturer of
**High Grade Spruce, Fir, Cedar
and Lumber of all Descriptions.**
CORRESPONDENCE SOLICITED.

W. B. McKECHNIE, President.

C. MacRAE, Manager.

THE ALBERTA LUMBER CO.

Vancouver, B. C. LIMITED

Manufacturers of
BRITISH COLUMBIA RED CEDAR

All sizes to 24 inches wide, by 24 feet long—CLEAR.
B. C. FIR—DIMENSION AND FINISH.

SCRIBNER'S LUMBER AND LOG BOOK

A handy book for Lumbermen. Gives Correct Measurements
of Scantlings, Boards and Planks; Cubical-Contents of Square
and Round Timber; Doyle's Rules, and much other practi-
cal information.

Price 35 Cents

ADDRESS THE CANADA LUMBERMAN, TORONTO, ONT.

1,500,000 Shingles Per Day

About half the B. C. Shingles used in Canada are sold by us. We have a Daily Shipping Capacity of One Million Five Hundred Thousand.

LUMBER

DOUGLAS FIR, SPRUCE and CEDAR Fir and Cedar Lath

DOORS, WINDOWS, MOULDINGS, NEWELS, BRACKETS, BALUSTERS and all descriptions of INSIDE and OUTSIDE FINISH

We make a Specialty of handling Timber Lands, Mill Properties and Lumber Investments generally
(Correspondence Solicited)

P. O. Box 407 **UNION LUMBER COMPANY, Limited** Head Office: 536 Hastings St. Vancouver, B. C.

The **WOODSTOCK LUMBER & MANUF'G. CO. Limited**
WOODSTOCK, ONTARIO
Wholesale Dealers in
HEMLOCK, PINE and HARDWOODS, SHINGLES and LATH,
And All Kinds of House Furnishings.

PEDWELL & LEMCKE, Lions Head, Ontario
MANUFACTURERS OF . . . Pine, Hemlock and Hardwood Lumber, Shingles, Ties, Poles, Posts, Etc.
Rail or Water Shipments. Correspondence Solicited.

BRITISH WOOD BROKERS AND IMPORTERS

FARNWORTH & JARDINE
Wood Brokers and Measurers
Cable Address "Farnworth," Liverpool. 2 Dale St., 71 Regent Road BOOTLE, LIVERPOOL. ENG

SMITH & TYRER - 14 Tithebarn Street, LIVERPOOL
.. WOOD AGENTS ..
Cable Address—"Walmer," Liverpool.
Halifax, N.S., Office—SMITH, TYRER & Co., Metropole Bldg., Hollis St. Halifax, N.S.

F. A. Lightbody & Co.
8 Gordon Street - GLASGOW, SCOTLAND
WOOD BROKERS
Cable Address: "TENEBRIS," GLASGOW. Codes: A. B. C., A 1, "Zebra" and Private.
Agents for CANADIAN WHITE PINE AND SPRUCE; Hardwoods in Log, Etc.
Shipments handled to the best advantage to all ports in the United Kingdom. Correspondence Solicited.

Edmiston & Mitchells
TIMBER BROKERS
Cable Address: "EDMISTON" Glasgow. 33 Renfield Street, GLASGOW

LOUIS BAMBERGER, 2 Broad Street Building, LONDON, E. C.
IMPORTER OF Pine, Spruce and all Canadian Wood Goods
Telegraphic Address "Bellywood, London."
Are Open to Contract for Glued-Up BASSWOOD KEYBOARDS

GANT & KEMP TIMBER BROKERS
52 St. Enoch Square, GLASGOW
Cable Address: "TECTONA" Glasgow. A 1 and A R C Codes used.

ZEBRA CODE A. B. C. CODE DIRECTORY CODE
GELLIBRAND, HEYWOOD & CO.
Wood Agents and Brokers
Cable Address: "GELLIGHT," LONDON 57 Gracechurch St. London, E.C. England

Telegrams and Cables: "Woodfeller, London." Codes: Zebra, Western Union, Southards, and A. B. C. 4th and 5th Editions.
THOMPSON, BLOIS & CO.
Buyers of all Kinds of Lumber and Logs
17 GRACECHURCH STREET: LONDON, E. C.
Cash advances made against shipping documents. Branches: MANCHESTER, HAMBURG.

FELBER, JUCKER & CO.
Lumber Importers
MANCHESTER ENGLAND
Invite offers from Lumbermen for . . .
Spruce Deals and Battens, Spruce and Pine Floorings, Shooks, Sashes, Mouldings, Dowels, Broom Handles, Chair Stock, Seats, etc., or any Woods Suitable for English Market.
Telegraphic Address: FELBER MANCHESTER.

ONE DOLLAR
Will pay your subscription to the CANADA LUMBERMAN for
ONE YEAR

JOSEPH OWEN & SONS, LTD.
Timber Importers
Cable Address "Owen Liverpool" Liverpool, Eng.
BUYERS OF
White Ash Logs and Planks.
Oak Logs and Planks.
Rock Maple Logs and Planks.
Rock Elm Logs.
Hickory Logs.
... ALSO ...
All classes of Lumber and Manufactured Wood Goods suitable for the English Market.

JAMES WEBSTER & BROTHER
BOOTLE, LIVERPOOL, ENGLAND
TIMBER MERCHANTS
BUYERS OF Oak, Birch, Ash, Grey Elm Logs and Lumber, Elm Staves and Heading, Handles of all descriptions
Veneers A Specialty

ALFRED DOBELL & COMPANY
WOOD AGENTS AND BROKERS
Liverpool and London Chambers - LIVERPOOL, ENGLAND
CABLE ADDRESS "DOBLE LIVERPOOL."

THE ONTARIO LUMBER CO. LIMITED

MILLS: North Bay. C.P.R. and G.T.R. Delivery.

WHITE PINE LUMBER, LATH AND SHINGLES.

35 and 36 Home Life Building TORONTO, Ont. MILLS: French River, Georgian Bay Water Shipment Only.

EMPLOYMENT BUREAU R. B. ST. GEORGE

RAILWAY, LUMBER and CONTRACTORS' AGENT 158 Canal St. Russell Block, Ottawa Men wanted at all times for Bush and Railroad Work. Phone 1,950

McLennan Timber Land and Lumber Co., Limited

Selling Agency and Dealers in all kinds of Timber Lands. Offices: Quebec, 131 St. Peter St. Ottawa, Room 9, Central Chambers.

CANADIAN LUMBER WANTED

We solicit consignments of long and short lumber from the Maritime Provinces and are prepared to purchase White Pine and Hardwoods in Ontario and Quebec.

ADDRESS: CHAS. S. WENTWORTH & CO. Room 510, 147 Milk St. - BOSTON, MASS.

BANK ST. CHAMBERS

OTTAWA, ONTARIO

W. B. BARTRAM & CO.

WHOLESALE LUMBER AND TIMBER MERCHANT

White Pine, Quebec Spruce and Hardwood. Specialties: Basswood and Birch. Barge or car load lots All Inquiries Given Prompt Attention.

J. GORDON MACLAREN

HINTONBURG, ONT.

DIMENSION TIMBER In Spruce, White and Red Pine, up to 40 feet. In Douglas Fir, up to 90 feet.

Every inquiry receives our Prompt attention. Write for quotations. B. C. Cedar Shingles SASH - DOORS - BLINDS

A. P. EBERT

MANUFACTURER OF AND DEALER IN

Pine and Hardwood Lumber, Lath, Shingles, Posts, Broom Handles, and Short Hardwood Dimension Stock WARTON, ONT.

CURRENT LUMBER PRICES--WHOLESALE

TORONTO, ONT.

CAR OR CARGO LOTS.

Table listing lumber prices for various types like 1 inch No. 1 Pine, 2 inch No. 1 Cuts, etc., with prices per 1000 ft.

Table listing prices for HARDWOODS—PER M. FEET CAR LOTS, including Ash White, Elm, Rock, Mill, etc.

QUEBEC, QUE.

WHITE PINE—IN THE RAFT

Table listing prices for Square white pine, measured off, 30 to 40 feet average.

RED PINE—IN THE RAFT

Table listing prices for Measured off, according to average and quality.

OAK—MICHIGAN AND OHIO.

Table listing prices for Elm, according to average and quality.

ASH.

Table listing prices for 10 inches and up, according to average and quality.

BIRCH.

Table listing prices for 14 inch, 16 inch, 17 inch, 18 inch.

OTTAWA, ONT.

MANUFACTURERS' PRICES.

Table listing prices for Pine, good sidings, 1 in x 8 in. and up, etc.

Table listing prices for Pine good strips, 1 in., 1 1/2 in., 2 in., etc.

Table listing prices for Pine, box boards, Pine mill culls, Spruce, 1 inch, etc.

SARNIA, ONT.

Table listing prices for UPPERS, 1 in., 10" and up wide, etc.

Table listing prices for SELECTS, 1 in., 8" and up wide, etc.

Table listing prices for FINE COMMON, 1 in., 8" and up wide, etc.

Table listing prices for NO. 1 CUTS, 1 in., 8" and up wide, etc.

Table listing prices for NO. 2 CUTS, 1 in., 6" and up wide, etc.

Table listing prices for NO. 3 CUTS, 1 in., 6" and up wide, etc.

Table listing prices for MILL RUN, 1" x 4", 1" x 5", etc.

Table listing prices for 1 1/2 x 4 and 5", 1 1/2 x 6" and up, etc.

Table listing prices for NO. 1 BARN, 1 in., 1 1/2" and 2" 29 to 32 00, etc.

Table listing prices for NO. 2 BARN, 1 in., 1 1/2" and 2" 23 to 25 00, etc.

Table listing prices for NO. 3 BARN, 1 in., 1 1/2" and 2" 20 to 22 00, etc.

Table listing prices for NO. 1, 1", 1 1/2", 1 3/4", 2", etc.

Table listing prices for MILL CULLS, Mill Run Culls 1", 1 1/2", etc.

Table listing prices for LATH, No. 1, 32", No. 2, 48", etc.

Table listing prices for SHINGLES, XXX W.P. or W. Cedar, 5 to 6 x 16", etc.

ALBANY, N.Y.

Table listing prices for Uppers, 3 in., 2 1/2 in., 1 to 2 in., etc.

Table listing prices for LATH, Pine, Sawed Pine ex. XXXX, Bound butts, etc.

BUFFALO AND TONAWANDA, N.Y.

WHITE PINE.

(Wholesale selling price.)

Table listing prices for Uppers, 1, 1 1/2, 1 3/4 and 2, 2 1/2 and 3 in., etc.

The following quotations on hardwoods represent the jobber's buying price at Buffalo and Tonawanda:

Table listing prices for WHITE ASH, 1st & 2nd, 1 inch, 36 00 38 00, etc.

Table listing prices for BLACK AND BROWN ASH, 1st & 2nd, 6 inch np, 33 00 35 00, etc.

Table listing prices for BIRCH, 1st & 2nd, 6 inch & np, red, 40 00 42 00, etc.

Table listing prices for ELM, 1st & 2nd, rock, 6 in & np, 6 00 28 00, etc.

Table listing prices for MAPLE, 1st & 2nd, hard, 20 00 23 00, etc.

BOSTON, MASS.

Table listing prices for White Pine Uppers, 1 to 2 inch, Selects, 1 to 2 inch, etc.

NEW BRUNSWICK CEDAR SHINGLES.

Table listing prices for Extras, Clears, Second clears, etc.

BRITISH COLUMBIA SHINGLES.

Table listing prices for Red Cedar Extras, 16 in. 5 butts to 2 in., etc.

BOILER INSPECTION IN ONTARIO.

Mr. James T. Burke, Inspector of Factories for Ontario, in his annual report to the Minister of Agriculture, refers at some length to boiler inspection. He says:

Preliminary to a boiler inspection, the boiler, flues, mud-drum, ashpit, and all connections should be thoroughly cleaned, to facilitate a careful examination. Blisters may occur in the best iron or steel, and their presence, and also that of thin places, is ascertained by going over all parts of the boiler with a hammer. When blisters are discovered, the plates should be repaired or replaced. Repairing a blister consists in cutting out the blistered space and riveting a "hard patch" over the hole on the inside of the boiler, if possible, to avoid forming a pocket for sediment. All seams, heads, and tube ends should be examined for leaks, cracks, corrosions, pitting and grooving, detection of the latter possibly requiring the use of a magnifying glass. Uniform corrosion is a wasting away of the plates, and its depth can be determined only by drilling through the plate and measuring the thickness, afterwards plugging the hole. Pitting is due to a local chemical action, and is readily perceived. Grooving is usually due to buckling of the plates when under pressure, and frequently to the careless use of the sharp calking tool. Seam leaks are generally caused by overheating, and demand careful examination, as there may be cracks under the rivet heads. If such cracks are discovered, the seam should be cut out, and a patch rivetted on. Loose rivets should be carefully looked for, and should be cut out and replaced, if found. Pockets, or hulging, and burns should be looked for in the firebox. The former are not necessarily dangerous, but if there are indications of their increasing, they should be heated and forced back into place or cut out and a patch put on. Burns are due to low water, the presence of scales, or to the continuous action of flames formed on account of air leaking through the brickwork. The burned spots should be cut out and patched as previously described. The conditions of all stays, braces, and their fastenings should be examined, and defective ones replaced. The shell of the boiler should be thoroughly examined externally for evidences of corrosion, which is liable to set in on account of dampness, exposure to weather, leakage, etc., and may be serious. The boiler should be so set that joints and seams are accessible for inspection and should have as little brickwork in contact with it as possible. The brickwork should be in good condition, and not have air holes in it, since they decrease the efficiency of the boiler and are liable to cause injury to the plates by burning, as above explained, and also by unevenly heating and distorting them. The mud-drum and its connections are liable to corrosion, pitting and grooving, and should be examined as carefully as the boiler.

All valves about a boiler should be easy of access, and should be kept clean and working freely. Each boiler should have at least three gauge cocks, properly located, and it is of the utmost importance that they be kept clean and in good order, and the same may be said of the glass water gauge. The middle gauge cock should be at the water level of the boiler, and the other two should be placed one above and one below it, at a distance of about 6 inches.

The conditions of the pumps or injectors should be looked into, to make sure that they are in the best working order. The steam gauge should be tested to ascertain that it indicates correctly, and if it does not it should be corrected. If the hydraulic test is to be used, the boiler should be tested to a pressure of 50 per cent. higher than that at which the safety valve will be set.

EXTERNAL INSPECTION WHEN BOILER IS UNDER STEAM.

The gauge cocks, and also the gauge glass, should be tried, to make sure that they are not choked. The steam gauge should be taken down, if permissible, and tested, and corrected, if necessary. The gauge pointer should move freely. Blowing out the gauge connection will show whether it is clear or not. The boiler connections should be examined for leaks. The safety valve should be lifted from its seat, to make sure that it does not stick from any cause, and it should be seen that the weight is in the right place. Observe from

the steam gauge if the valve blows off at the pressure it is set for. See that all pumps and feed apparatus are working properly, and that the blow-off and check valves are in good order. Blisters and bagging may sometimes be detected in the furnace. The condition of the brickwork is of considerable importance, since the existing of air-holes is a source of trouble, as already explained.

INCRUSTATION. One of the chief sources of trouble to the boiler user is that of incrustation. All water is more or less impure; and as the water in the boiler is continuously evaporated, the impurities are left behind as powder or sediment. This collects on the plates, forming a scaly deposit, varying in nature from a spongy, friable texture to a hard, stony one. This deposit impedes the transmission of heat from the plates to the water and often causes overheating and injury to the plates. The various impurities in the water may be either in suspension or solution. If the former, the water can be purified by filtration before going into the boiler. If the latter, the substances must be first precipitated and then filtered. Many impurities may be removed by heating the water before feeding it into the boiler. The first thing to do, when dealing with a water supply, is to have an analysis of it made by a competent chemist. The fact that water contains a certain amount of solid matter is no criterion as to its unfitness for boiler use. The presence of certain salts, as carbonate or chloride of sodium, even in large quantities, would not be serious if due attention were given to the blowing off. On the other hand, salts of lime in the above proportion would be very objectionable, requiring greatly increased attention in the matter of purification and blowing off or else cleansing out.

The various methods of dealing with impure water may be classed as follows:

1. **FILTRATION.** Where the matter is held in suspension, it can be removed, before the water enters the boiler, by the aid of settling tanks or by filtering, or by forcing the water up through layers of sand, broken brick, etc., or by using filtering cloths in a proper machine.

2. **CHEMICAL TREATMENT.** Clark's process combined with a frequent filtration (the joint process being known as the Atkins system), has been successfully applied on small and large scales in the chalk districts of England. Lime water is mixed with the water to be purified, the amount used depending on the composition of the water as determined by a careful analysis. The lime is thus precipitated, and the water is then filtered in a machine containing travelling cotton cloths. Not only is the carbonate of lime entirely removed, but it has been proved that any sulphate of lime that may be present is also prevented from incrusting. This is important, as the latter impurity forms, perhaps, the worst scale one has to contend with.

Various chemical compounds are in use for boilers. Carbonate of soda is perhaps the best general remedy. It forms the basis, in fact, of nearly all boiler compounds, whatever their name or appearance. This soda deals efficaciously both with the carbonate and the sulphate of lime. The precipitates thus thrown down do not form a hard crust; they can be washed out in the form of a sludge or mud.

Carbonate of soda is also useful where condensers are employed, as it counteracts the effect of the grease, which is brought over with the exhaust steam. If used in too large quantities, it will cause priming. The best way to use it is to make a solution of it and connect with the feed, fixing a cock so as to regulate the amount fed in. Soda ashes is much cheaper, but more of it is required, and, besides, it is generally impure. Caustic soda removes lime scale quicker than ordinary soda does, but it is much stronger and liable to attack the plates. It should be used in smaller quantities than the ordinary kind.

Barks, molasses, vinegar, etc., develop acids that attack the plates. Animal and vegetable oils do the same, and also harden the deposits, and make their removal more difficult. It is a good rule to keep all animal and vegetable matter out of boilers altogether.

FEED-WATER HEATERS. Carbonates and sulphates of lime are precipitated by high temperatures. The heaters should be arranged so that the deposit forms chiefly on a series of plates that can be easily removed

for cleaning. If the deposit gathers in pipes, however it is simply transferring the evil from one vessel to another. A double advantage is gained by these heaters, for the feed water is put into the boiler already heated, and so fuel is saved.

MECHANICAL AIDS. Deposits take place chiefly in sluggish places. Various devices to aid circulation have been brought out. With good attention and a not too impure water, they give satisfactory results.

Potatoes, linseed oil, molasses, etc., are sometimes put into the boiler with the idea of lessening scale formation, by forming a kind of coating around the particles of solid matter and so preventing their adhering together. This certainly takes place, but the substances are injurious, as already pointed out. Whenever a boiler has been cleaned out, we may with advantage give the inside a thin coating of oil, or tallow and black lead; this arrests the incrustation to a great extent.

Sand, sawdust, etc., are often used, the idea being that their grains act as centres for the gathering together of the solid matter in the water, the resulting small masses not readily collecting together themselves being easily washed out. This may be so, but the cocks, valves, etc., are liable to suffer from the practice.

Kerosene is strongly recommended by some boiler users. There is no doubt that in many cases its use has given good results. It prevents incrustation, by coating the particles of matter with a thin covering of oil, the deposit thus formed being easily blown out. The oil also seems to act on the scale already formed, breaking it up and thus facilitating its removal. As already remarked, it is a good plan, when the boiler is empty, to give the inside a good coating of this oil, afterward putting it in with the feed, the supply being regulated automatically. As to the quantity required, this will be found to vary in different cases, according to the nature of the water; an average of one quart per day for every 100 horse power will give good results in most cases.

In marine boilers, strips of zinc are often suspended; the deposit often settles on them instead of on the boiler plates. Also, any scale that may be formed on the latter is less hard and compact and more easily broken up. Further, any acids formed by the oil and grease brought over from the condenser attack this zinc instead of the boiler plates.

MISCELLANEOUS. Acids are often introduced into boilers to dissolve the scale already formed, the solid matter then being washed out. This treatment should be adopted with great care if at all, as the plates are likely to be affected.

Scale is often loosened and broken up by deliberately inducing sudden expansion or contraction in the boiler. In the former case, the expansion is brought about by blowing off the boiler, and then, when it is quite cooled down, turning on steam at as high a temperature as obtainable, thus causing the scale to expand more quickly than the plates and thus become loose.

In the second method, the boiler is blown off when the steam is at its highest, and a stream of cold water is then turned in. The fires are then drawn, and the fire-hole doors, dampers, etc., opened, letting in a rush of cold air. All this cools the plates, and, by the contraction thus brought about, loosens the scale. These two practices should be guarded against.

Foaming or priming is usually due either to forcing a boiler beyond its capacity for furnishing dry steam, or to the presence of foreign matter. It is dangerous if occurring to any great extent, since water may be carried along with steam into the engine, and a cylinder head knocked out. Foaming when it cannot be checked by the use of the surface blow-out apparatus, may necessitate the emptying of the boiler, which must then be filled with fresh water; this rids the boiler of the impurities that have collected during the operation of the boiler.

MEETING OF WHOLESALE LUMBERMEN.

The fourteenth annual meeting of the National Wholesale Lumber Dealers Association will be held on Wednesday and Thursday, March 7th and 8th, 1906. The place of the meeting has not yet been decided upon.

THE Wood-Worker and Retailer

BALUSTER TURNING MACHINE.

A tool that should prove of special interest to all manufacturers of balusters, spindles, light table legs, etc., is shown in the accompanying illustration of the Mattison No. 2 baluster machine. It has an average capacity of 1000-1200 pieces per day, and will turn in round or octagon all the delicate patterns heretofore requiring hand work. The quality of the work is equal to that done by hand, and every piece comes out exactly alike in size and shape.

One of the main features of this machine is

perfectly firm, free from chatter or vibration.

The turning attachment is supported by an oscillating carriage, designed to admit of any necessary adjustment. It works on a rocker shaft and is operated by a powerful compound lever feed, which, in connection with resisting cushion springs, enables the operator to feed the work against the cutters with ease and perfect safety. When the carriage reaches the stop the toggle link arrangement practically locks it, so that it is held rigidly in place while the cut is being made.

In the cutter system is also embodied

AUTOMATIC WOOD BENDING MACHINE.

The engraving on opposite page represents the patent 12 in. automatic wood bending machine which has been designed and is manufactured by the Defiance Machine Works, of Defiance, Ohio. It is claimed to meet all the requirements for the successful and economical bending of felloes for carriage and wagon wheels, wagon hounds, carriage bows, reaches and other similar classes of bent wood stock.

It is capable of bending the lightest felloes used for carriage wheels, up to the heaviest work required for farm wagon, truck and artillery wheels, bending hardwood as large as 5 in. in thickness, 12 in. in width, with adjustments sufficient to accommodate changes from 17 in. to 72 in. circles; also wagon hounds to any circle required, and carriage bows from 36 in. up to 44 in. wide; the form for this work is adjustable to bend any widths between the sizes specified.

The frame is a massive casting, and is substantial in all its parts. Its total height is 9 ft. 9 in., and the floor space necessary to accommodate it is, length, 14 ft.; greatest width, 6 ft.; lesser width, 4 ft. A foundation of masonry is not required under the machine, as an average floor well supported is sufficient.

It embodies an entirely new feature in the application of power, the object being a drastic longitudinal stress upon the timber to be bent. This is secured by means of an elastic cable railway held taut by four powerful springs which are capable of exerting an aggregate energy of six thousand pounds. Upon this railway roll the trucks by which are carried the inner or lower ends of the levers, or bending arms, long experience in the art of bending timber proving this action to be necessary to secure a shape in satisfactory agreement with the form upon which the timber is bent.

The levers or bending arms form a level table when down, and are covered with a master strap to receive the straight material. They are of cast iron, made hollow and strongly reinforced. They are planed true on the upper surfaces and otherwise fitted up with extreme care. The head blocks mounted upon their upper surfaces are furnished with an automatic eccentric releasing device to release the augmenting end thrust which occurs during the process of bending.

The chain drum is driven by a powerful worm screw and gear. To the outer end of the screw shaft two frictional clutch pulleys are fitted, one used for running the bending levers up, and driven with a 6 in. belt,



BALUSTER TURNING LATHE MANUFACTURED BY C. MATTISON MACHINE WORKS.

the work-holding device. The stock is not held between centers, as it is a well known fact that where this method is used to hold long, slim stock, it is impossible to prevent springing and vibratin, no matter what style of cutter-head is used. The work-holding device consists of two sets of self-centering V-shaped chucks, each having a bearing of sufficient length to give a good leverage, these chucks gripping the stock at each end close up to the cut. They are constructed on the principle of a scroll chuck. Both ends of the stock are clamped by the operation of a lever, and are rotated simultaneously. A friction brake is used to control the movement of the jaws, so that in case the stock should not be of an even thickness on both ends, the clamps will adjust themselves to it automatically. This device, together with the steady rest in middle of piece, insures the work being held

another very valuable improvement. The steel cylinder head is provided with six dovetailed slots, into which are fitted the knife holders. These are adjustable and can be removed at any time without loosening the knife when grinding. The knife is held on the carrier in such a position as to make a perfect shear cut. All the knives are made of plain tool steel, and any man who can make the knives for a moulder or shaper can make them for this machine as well. This is a point not to be overlooked, for it means the cutting down of a big item of expense in the cost of extra knives, and also does away with the delays incurred where it is necessary to order the knives of the manufacturer.

Circulars giving full description, together with sample of work turned out, can be had of the manufacturer, the C. Mattison Machine Works, Beloit, Wisconsin.

FOR THE CAMP

We have a very suitable lot of goods for camp supplies. We make this kind of trade a specialty. You who are not getting suited just as well as you would like, try us for your next order, and give us a chance to demonstrate our ability to give you satisfaction in this very important department of your business.

H. P. ECKARDT & CO.

Wholesale Grocers

TORONTO

the other with a 5 in. belt for backing the arms down, and they should revolve in opposite direction. The vertical lever shown is used to control the frictions and start, stop or back down the bender arms.

The forms for the bending of felloes are of cast iron, turned true, and with a collapsible friction at each end of the arc to secure the easy removal of the stock after bending, and enabling the use of stock about 9 in. shorter than can be bent with an ordinary form, which effects a large saving in material. A wooden

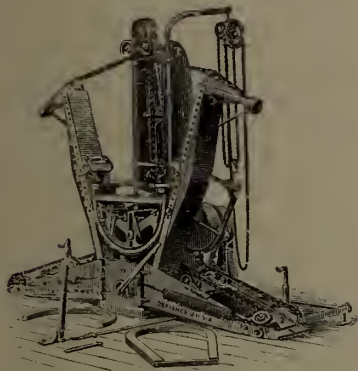

12 IN. PATENT AUTOMATIC FELLOE, HOUND AND BOW BENDING MACHINE.

cap is used on top of the form, which is of the same length as the diameter of the form, and is always taken off with the bent wood, requiring one cap for each batch of timber bent, and it must be left in until the batch of timber is cold and thoroughly set, so as not to spring when the shackle is taken off. The forms are held on a sliding head stock, having a vertical movement, by means of which the timber can be firmly held at the initial point of bending, thus securing it against fracture on the outer arc, and preventing it from retreating from the form at that point. After the operation of bending is completed the machine can be set to run down to the position for the succeeding operation and automatically arrested.

The capacity of this machine is sufficient to bend about 2,500 felloes 1½ in., or about 1,200 wagon hounds in ten hours, and other classes of work in proportion. Timber to the amount of 12 in. in width, either in one piece or pieces aggregating that amount, can be bent at one operation.

Robert Shouldice, a hand logger, was killed at Funderick's Arm, B.C., by a log rolling over him.

OBITUARY.

THOMAS BRYCE.

After a somewhat prolonged illness, Thomas Bryce, a well known citizen of Toronto, died at his home on Woodlawn avenue on November 6th. Forty years ago Mr. Bryce came to Toronto from Symington, Scotland, and, with his brother, engaged in the lumber and building business. They operated a planing mill on the water front at the foot of Berkeley street and continued to do a successful business for many years.

A few years ago Mr. Bryce was elected as an Alderman for Ward 2, but retired after one year of service. Later he accepted a position on the Court of Revision, where his judgment was highly regarded. He was prominent in society circles, being a Mason and a member of St. Andrew's Society, the Caledonian Society and the Sons of Scotland. Personally he was highly esteemed, having a sympathetic disposition and a modest demeanor. Mrs. Bryce and one son and one daughter survive him.

DONALD S. MCLEAN.

Donald S. McLean, of McLean Brothers, wholesale lumber dealers, North Tonawanda, N. Y., died November 4, at Detroit, Mich., from heart disease and congestion of the lungs, for which he had been under treatment about three weeks. Deceased was born in Linton, York county, Ont., October 14, 1855. He was educated in the public schools at Georgetown and Collingwood. After teaching school for about three years he left Canada and went to Detroit, Mich., where he entered the employ of Robinson Brothers, with whom he learned the lumber business. He travelled for Robinson Brothers as salesman for a number of years, and also for Miller & Lewis, of Bay City, Mich. Afterwards he was with Henry W. Sage & Co., of Albany, N. Y., as manager of their business at that point. In 1892 he started into business with his brother Hugh, with headquarters at Rhineland, Wis., under the name of McLean Brothers. In 1897 the firm moved to North Tonawanda, N. Y. Mr. McLean continued to reside in Albany, from which point he looked after the Eastern end of the firm's business, until 1901, when he moved to North Tonawanda.

KILGOUR SHIVES.

Sad, indeed, was the tragic death of Mr. Kilgour Shives, manager of the Shives Lumber Company, Campbellton, N.B. Sincere sorrow was felt throughout the province, and especially in the district in which he lived, for all who knew him realized his great worth.

Mr. Shives, in company with Mr. MacLean, his millwright, went up the river towards the lumber camps of the firm, and while walking through the woods, the trigger of a rifle he was carrying was caught by the brush and the charge set off. The bullet entered Mr. Shives' body on the right side, passing clean through the body and coming out just below the heart. The unfortunate man remained conscious for a short time, but fully realizing his condition, gave directions concerning his business and a last word of farewell for his wife and family.

Although Mr. Shives had not passed the prime of life, he had accomplished much and had fairly begun much larger and more promising activities on behalf of himself and others. He was easily one of the most prominent mill men of New Brunswick and was fully trusted and greatly respected by all who had business dealings with him. Few men had a larger circle of personal friends. He was a quiet, unostentatious gentleman, with a genial, kindly disposition and a generous heart, making warm friends wherever his acquaintanceship extended. After combating many difficulties he had succeeded in establishing a great business venture, alike profitable to himself and the province, but, alas, he has been cut down in the very prime of manhood, and in the midst of his great activity.

Mr. Shives was the manager and secretary-treasurer of the Shives Lumber Company, and carried on extensive lumbering operations on the Restigouche river and its tributaries. The company operate a shingle mill and saw mill in Campbellton and a large saw mill on the Restigouche river just below Ferguson's Point, about four miles above Campbellton. Mr. Shives has been for the last fifteen years one of the largest lumber operators on the Restigouche, one of the largest employers of labor, and one of the foremost citizens of Campbellton. He was the son of the late Alexander Shives, who conducted a lumber business at Salamanca, near Fredericton, running the mill now owned by J. A. Morrison. Here Kilgour Shives was born forty-eight years ago. He was educated in St. John and in 1877 took charge of the mill on the Strait Shore, then owned by his father and uncle. For about three years he conducted that business, and in 1880 the mill which is now known as the Warner. Then Mr. Shives spent some years at Dunsmane, a mile beyond Sussex, where he managed a mill owned by his father. After that he went to Campbellton, where he started milling operations on his own account on a small scale at first, but gradually extending his plant as business increased. His business increased so that it came to be one of the most important of its kind in the province, and was a few years ago turned into a joint stock company, of which Col. Cutler, of Stetson, Cutler & Company, is president. The company own very extensive timber limits both in New Brunswick and Quebec.

In addition to his lumbering operations, Mr. Shives was one of the promoters of the Restigouche and Western Railroad, of which he was president for two years. Since it became the International Railroad he has been president for three years, holding this position at the time of his death. These were the only two enterprises in which he was engaged.

In his earlier life Mr. Shives was an active member of the militia, and was noted as being one of the best shots in the province—a gift which is possessed in an almost equal degree by his sons. He was on several occasions a member of the Wimbledon team, and has won many prizes in both England and Canada.

Mr. Shives married Miss Minnie Mills, daughter of the late William Mills, of St. John. They had five children, all of whom survive.

A word to the reader: Send us a contribution for the January number. Your experience in some particular instance is certain to be interesting to somebody else.

THE NEWS

ONTARIO.

—The Temagami Lumber Company are building a large saw mill at Callender, Ont.

—The death took place last month of M. Lottridge, saw mill owner, Newholme, Ont.

—It is stated that the Empire Lumber Company will build a large saw mill at Latchford, Ont.

—It is reported that the Rat Portage Lumber Company will build a new saw mill at Fort Frances, Ont.

—Thomas McGill, of Kearney, Ont., has submitted a proposition to the Town Council of Cornwall, Ont., to establish a chair factory at that place.

—The Ross-Taylor Company, Limited, of Exeter, Ont., have doubled the capacity of their dry kiln and installed one of Sheldon & Sheldon's natural draft dry kilns.

—A. Tait's saw mill at Orillia, Ont., which has been in operation for the past thirty years, is being offered for sale. It is probably the oldest manufacturing plant in the town.

—Improvements will be made this winter to most of the saw mills at Owen Sound, Ont., including those owned by John Harrison & Sons, Maitland, Rixon & Company, Keenan Brothers and J. S. Findlay.

—Charles Mueller, of Waterloo, Ont., proposes to erect a new coopeage plant with at least double the capacity of his present establishment. The town has been asked to give a small bonus.

—The Keewatin Lumber Company have not yet taken steps towards the rebuilding of their saw mill at Keewatin, Ont. It has been rumored that an American firm had obtained an option on the site for a flour mill.

—The ratepayers of the Township of Sarawak last month voted in favor of granting exemption from taxation to the Manning Wood Fibre Company, of Toronto, to establish a factory there for the manufacture of excelsior.

The Huron Lumber Company, operating a saw mill at Spanish River, Ont., with an annual capacity of 20,000,000 feet, is reported to have sold the mill to the Spanish River Lumber Company, by whom it has been stocked with logs the last five years.

—The Liskeard Brick, Coal and Lumber Company, Limited, has been incorporated, with headquarters at Toronto and a capital of \$40,000. It is proposed to acquire the business now carried on at New Liskeard, Ont., by Ord Brothers, and to engage in the manufacture of brick, tile, lumber, etc.

—The C. Beck Manufacturing Company, Penetanguishene, Ont., have been making improvements to their saw mill and have installed a steam and oil separator and an automatic feed pump and receiver, with outside packed plunger pump with pot valves.

This apparatus was purchased from the Smart-Turner Machine Company, of Hamilton.

—The Turner Lumber Company have, as a matter of business convenience, changed their head office from the town of Midland to the city of Toronto, their new address being National Life Chambers, 25 Toronto street. They will continue to manufacture the logs from their limits at Midland or other Georgian Bay points, and also at South River, and will have representatives at Midland, South River and Cutler. All sales, however, will be made at the head office in Toronto.

THE EASTERN PROVINCES.

—William Potter is about to build a saw mill at Canning, N. S.

—La Macaza Shingle and Lumber Company, La Macaza, Que., has been dissolved.

—Albert Prevost, sash and door factory, Papineauville, Que., has discontinued business.

—J. & T. Jardine, of Richibucto, N. B., have sold the Mundle saw mill on the Main river.

—The Industrial Company, of Chicoutimi, Que., has been incorporated, to deal in lumber, etc.

—Pratt Bros., Incorporated, Sellarville, Que., have obtained a charter to carry on a lumber business.

—John W. Quinn has registered the lumber business of B. Quinn & Company, Windsor Mills, Que.

—N. H. Roy, general store and saw mill, Elm Tree, N. B., has been succeeded by Roy & LeVasseur.

—The A. I. Wright Company have just completed the construction of a new saw mill at Salisbury, N. B.

—Mrs. John A. Bulmer has registered as proprietress of the lumber business of John Bulmer & Company, Montreal.

—The Roxton Mill & Chair Manufacturing Company, Roxton Falls, Que., has been dissolved and a new company registered to carry on the business.

—It is expected that the Davison Lumber Company will operate their mill at Bridgewater, N.S., all winter, for which purpose a steam pond is now being constructed.

—E. S. Marchesseault has recently sold his lumber business at Farnham, Que., to Roy & Potoin. Mr. Marchesseault has left Canada for France, where he will in future reside.

—The Newville Lumber Company are rebuilding their saw mill near Parrsboro, N. S., which was recently destroyed by fire. The Robb Engineering Company will supply the boilers and engines.

—A new company has been incorporated, under the name of J. & T. Jardine, Limited, to take over the lumber and milling business now carried on by J. & T.

Jardine at Rexton, N. B. The capital of the new concern is \$75,000.

—The Scott Lumber Company, of Fredericton, N.B., have built a new mill at Bailey Creek, near Fredericton Junction, which will be devoted exclusively to the manufacture of laths for the American market.

—The Improved Match Company, Limited, recently celebrated the opening of their new factory at Drummondville, Que. The building is a brick structure three stories high and lighted by electricity, the machinery being operated by water power.

—John Fenderson & Company, of Sayabec, Que., are building a new circular mill at River Rogue, about twelve miles from Sayabec, which it is intended to operate in the winter. It will cut about 20,000 feet daily and start running about January 1st.

—C. M. McKenzie, A. J. Craig and J. W. Hogg have entered into partnership, under the name of C. M. McKenzie & Company, to manufacture and deal in all kinds of lumber at Pictou, N.S. The lumbering operations will for the most part be conducted in Pictou county.

—E. E. Ring, state forestry commissioner of Maine, estimates that there is now standing in that state 21,000,000,000 feet of spruce. The timber area of the St. John river is placed at 7,400 square miles, containing 6,942,000,000 feet of spruce, 427,000,000 feet of pine, and 1,830,000,000 feet of cedar.

—T. E. Babbitt & Sons are now manufacturing lumber, shingles, lath, etc., at their new mill at St. Mary's, N.B. The shingle machines were manufactured by the well-known firm of McFarlane, Thompson & Anderson, of Fredericton, N.B., and the rotary mill by Lloyd & Son, of Kentville, N.S.

—The Miramichi Lumber Company, who have acquired the property of the William Richards Company, Chatham, N.B., intend introducing modern methods of lumbering. Saws will be used exclusively in cutting down trees, thus effecting a saving in timber. The tops of trees will be used for pulp wood, to be driven to the Chatham booms and barked at a mill to be built there.

—The Fredericton Boom Company will apply at the next session of the Legislature of New Brunswick for amendments to the acts relating to the company, and among other things to provide for an increase in the tolls and charges for securing and rafting logs and lumber as follows: Pine timber, from thirty-five cents to fifty cents per ton; hackmatack timber, from sixty cents to seventy-five cents per ton; spruce and pine logs and other lumber, excepting cedar, from eighty-five cents to one dollar per thousand superficial feet; cedar of all kinds, from one dollar and thirty cents to one dollar and forty cents per thousand superficial feet; spruce and pine logs belonging to any one owner

TENTS

That are the acme of perfection, in all details of work. BRITISH ROYAL NAVY method of cut, workmanship and finish. MATERIAL used made in SCOTLAND by the Navy Contractors. Samples and prices are mailed on request.

TOBIN TENT & AWNING CO. OF OTTAWA Long Distance phone No. 432

CRAIG MINE CRYSTAL CORUNDUM WHEELS

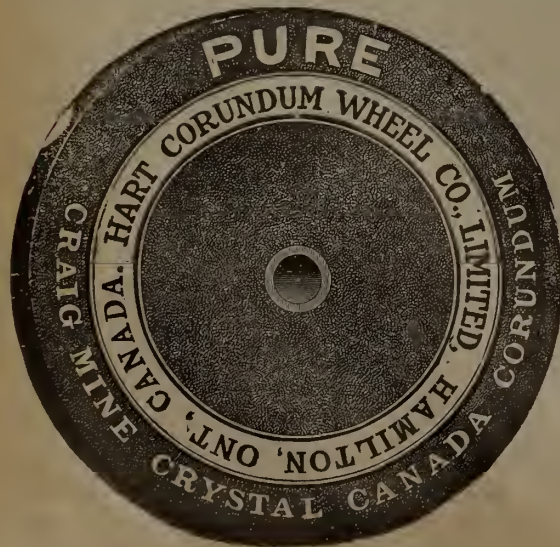

Our Pure Crystal Corundum Saw Gummars have no equal for their Rapid, Cool, Cutting Properties.

Read the following from Bulletin 180 of the United States Geological Survey, which says:

"Often a distinction is made between emery and corundum, many persons not recognizing emery as a variety of corundum

Emery is a mechanical admixture of corundum and magnetite or hematite. It is, of course, the presence of corundum in the emery that gives to it its abrasive qualities and makes it of commercial value, and the abrasive efficiency of emeries varies according to the percentage of corundum they contain."

Emery is imported, mined by Greeks and Turks and contains only about 25% corundum. Our Crystal Corundum is guaranteed to be 98% pure alumina, a Canadian product, mined and manufactured by Canadians for Canadians.

HART CORUNDUM WHEEL COMPANY, Limited, Hamilton, Ont, Can.

averaging less than seventy superficial feet, from six cents to seven cents each.

—J. Newton Pugsley, of Parrsboro, N.S., will in future conduct a direct export trade in lumber. He has established permanent business connections with John E. Moore, of St. John, N.B., and will make regular shipments from West Bay direct to the European, South American and United States markets. In addition to the shipment of the output of his own mills, he will purchase the stocks of other operators. Mr. Pugsley has engaged Alonzo O. Seaman as confidential clerk and assistant manager, and their combined ability, experience and energy should ensure the success of the enterprise.

MANITOBA AND THE TERRITORIES.

—The Great West Lumber Company, Limited, are commencing in Winnipeg.

—Miller & Robinson have opened a lumber yard at Lloydminster, Saskatchewan.

—The J. C. Graham Lumber Company will build a large warehouse in Winnipeg.

—Duffs & Clements, lumber and hardware dealers, Olds, N.W.T., have sold their lumber business to F. D. Becker.

—The National Supply Company has been incorporated at Winnipeg, Man., to manufacture and deal in builders' supplies, lumber, etc. The promoters include A. T. Davidson and W. Welfley, contractors.

—The Independent Lumber Company have completed the building of their lumber yards at Moose Jaw, N.W.T., and Mr. Steward has been appointed local manager. At present they have twenty-three yards throughout Manitoba, Saskatchewan and Alberta.

—The Land, Log and Lumber Company, Limited, has been incorporated at Winnipeg, Man., with a capital stock of \$300,000. The charter gives the company power to carry on the business of lumbering in all its branches. The incorporators are: J. S. Lovell, William Bain, Robert Gowans, E. W. McNeill and W. F. Ralph, all of Toronto.

BRITISH COLUMBIA.

—The King Lumber Company, of Cranbrook, B. C., are erecting a mill at Yahk, B. C., where they have extensive limits.

—The Cranbrook Sash & Door Company, of Cranbrook, B. C., are putting in a dowel door making plant with complete equipment of six machines.

—J. S. Emerson, of Vancouver, B. C., expects to have his new mill at Greenway Sound completed at an early date. It is located 300 miles north of Vancouver.

—The Canadian Lumber & Timber Company, Vancouver, B. C., have applied for permission to purchase forty acres of land situated near Rocks Falls, west of Howe Sound, and adjacent to their mill.

—The Big Bend Lumber Company will double the capacity of their mill at Arrowhead, B. C. The contract for the necessary machinery has been given to the Waterous Engine Works Company, of Brantford, Ont.

—Proctor & MacDougall, of Fernie, have started a new retail yard at Pincher Creek, where they are carrying a stock of all kinds of lumber. W. J. Finlick is in charge. A planing mill has been built there also.

—The machinery for the new mill of the Small & Bucklin Lumber Company at New Westminster, B. C., has arrived and is now being installed. The company hope to have the mill in operation by the first of the year.

—The saw and shingle mill to be built by the Seattle Cedar Manufacturing Company, to which reference was made in the November number, will be located on Mosquito Harbor, while a second mill of smaller size will be constructed at Nootka. McEwen Brothers, of New York, are behind the enterprise.

—Watts & Company, of Wattsburg, B. C., intend putting in a new dry kiln this winter and increasing the capacity of their mill to about 40,000 feet per ten hours by the installation of a new boiler and engine of 120 h.p. At present the wooden stave pipe department is shut down, but this will be resumed during the winter.

—Ross Bros., lumber manufacturers, Elkmouth, B. C., are doing some dredging leading from the Kootenay river to their mill, to permit the floating of logs right to the mill at exceedingly low water. This winter they intend building a larger boiler house and adding another boiler. They intend also to increase the motive power to enable them to maintain a full cutting capacity of 45,000 feet per day of ten hours. A new planer will probably be installed in order to cope with the increased output of the mill.

The Kimberley Milling & Manufacturing Company, of Kimberley, B. C., of which Chas. A. Gaskell is manager, intend building a large refuse conveyor at their plant this winter and installing a complete live roll system for loading cars direct from the saw. A change was made in the personnel of this firm recently, Mr. Chas. Spilstead having sold his interest to Mr. Gaskell and moved to Edmonton. The limits owned by this company are all around Mark Creek and occupy property owned by the North Star Mining Company.

—The Robinson-MacKenzie Lumber Company, of Cranbrook, B. C., are busy at present taking out logs for their next year's cut. This work will continue for a month or two yet. They expect to put in a new logging railroad about six miles long, to run from the main line of the C.P.R. Crow's Nest Pass branch past the mill and about four miles into the bush. Owing to the slowness of the Railway Commission at Ottawa in granting final permission the road is at present in abeyance and may now have to be postponed for another year. In their mill they are installing a new

planer and are contemplating the installation of a new carriage with gunshot feed and steam loader nigger and kicker and a new edger. This, with the new boiler and engines recently put in, will make the plant practically a new one and give a cut of 50,000 feet per ten hours.

—The Revelstoke Lumber Company's new mill at Revelstoke, B. C., is being built as rapidly as possible. The foundation for the superstructure is of concrete. The engine and boiler house is a separate building, built of brick and fireproof. The main building will be 36 x 126 feet, and the planer room will run off the main mill building in the form of an L and will be 84 x 74 feet. Each building will be two stories in height. The electric light plant will include a 500 light dynamo driven by a 50 horse power engine. The capacity of the mill will be about 125,000 feet per day, running two shifts, and it is expected to be completed by April 1st.

PERSONAL.

Mr. E. Todd, who has conducted a retail lumber yard at Brantford, Ont., for a number of years, has retired from the lumber business and purchased a 600 acre farm near Caledonia, Ont., to which he will devote most of his attention. He may, however, handle some lumber in a wholesale way.

Mr. W. S. Gore, who for thirty years has been Deputy Commissioner of Lands and Works for British Columbia, has retired from the service and has been succeeded by Mr. N. F. McKay, who has been private secretary to the Premier. Mr. Gore is one of the oldest officials in the civil service and is held in high esteem.

Mr. Robert Moore, who has represented Pettibone & Douglas, lumber exporters, Polo, Illinois, for several years, and has resided at Gravenhurst, Ont., in which district he has become widely known among lumbermen, has removed to 131 Gladstone avenue, Toronto. He will continue to represent the above named firm, who make extensive shipments to Great Britain.

The death occurred on October 26th of Mr. Michael Purtle, of the McInnes & Purtle Lumber Company, of Elkmouth, B.C. Deceased contracted a cold by getting wet while engaged in his work, which was followed by an attack of typhoid fever that resulted in his demise after but ten days illness. The late Mr. Purtle hailed from Sussex, N.B., where he gained his first experience in the lumber business, which he followed all his life. Coming to British Columbia one year ago, he formed a partnership with Mr. McInnes in July last and immediately took an active interest in the business. The remains were embalmed and shipped back to his brother, Mr. Dennis Purtle, of Sussex. Mr. Purtle was a widower and leaves a daughter twelve years of age.

RAILS and TRACK SUPPLIES

NEW and Re-Laying from 12 to 60 lbs. per yard with fastenings; for Lumbering, Mining and Contracting Work. Immediate shipment from Stock. Get our prices before purchasing.

SESSENWEIN BROS.,
101 Shannon Street, Montreal

CONSULT YOUR FILER . . .



Hanchett Circular Saw Swage

about that new swage or swage shaper you are going to buy, and if he has never used our tools just drop us a line and we will gladly send free for 30 days' trial one of our

HANCHETT ADJUSTABLE SAW SWAGES OR SWAGE SHAPERS

The Hanchett Swages have stood the test of years. They are standard make, and a customer who purchases one knows he is getting the best money can buy. Sold with unqualified guarantee.

Send for our new Catalogue "F". It tells all about our Saw Swages and Swage Shapers. Free for the asking.

Manufacturers of complete outfits for the filing room.

HANCHETT SWAGE WORKS, BIG RAPIDS, MICH., U.S.A.

WANTED—A SALVAGE LAW.

It would indeed be interesting to know the quantity of timber that is lying at the bottom of the rivers, lake and creeks in Canada on which lumbering operations have been conducted. There are doubtless many millions of feet, which, if recovered, would be worth a large sum of money. Propositions looking to the recovery of some of this timber have been considered, but one of the drawbacks seems to be the absence of a salvage law in respect to sunken logs. As is well known, nearly all logs bear the hammer mark of the owner and would therefore legally be his property when recovered. Another person raising them would have no guarantee of a return for his labors unless by previous arrangement with the owner. If there existed a salvage law by which, under certain conditions defined therein, the logs would become the property of the person raising them, we believe there would soon develop considerable activity in this direction.

Where certain firms have carried on lumbering operations on a stream for a number of years, it would seem to be advisable, even in the absence of a salvage law, to take united action towards the recovery of the sunken logs, as timber is now too valuable to be left lying in the beds of streams if it can be recovered by reasonable efforts.

DEATH OF WINNIPEG LUMBERMEN.

Within a couple of weeks the grim reaper, Death, has made sad havoc at Winnipeg among the lumber fraternity. What renders it especially sad was that in the death of three of these lumbermen the Order of Hoo-Hoo loses three good members, whilst all of them were young men—men who had been looked upon as among the coming generation of western business men.

The first was Daniel Lewis Lincoln (Hoo-Hoo No. 9980), who has been buyer for the Imperial Elevator Company, at Winnipeg, for some years. His health suddenly failed, tuberculosis developed, and he went to Pueblo, Colorado, where he died. He was buried at his former home in Livermore, Iowa. "Dan," as he was familiarly called, was formerly buyer for the J. & W. C. Shull Lumber Company, Minneapolis, and a splendid young business man. The Hoo-Hoo sent a beautiful wreath and resolution of regret to his family.

Thaddeus R. Case (Hoo-Hoo No. 5715), of Winnipeg, Man., died suddenly on November 10 at Calgary. The cause of Mr. Case's demise was heart failure and suffocation. He was a member of the firm of Case & Chandler, of Winnipeg, and later of the J. C. Graham Lumber Company, and had resided in that city for many years. He was one of the first lumber merchants to introduce American lumber into the Canadian West, and had enjoyed a great measure of success in his business operations. Mr. Case was 38 years of age. He went to Winnipeg as the representative of the Pine Tree Lumber Company. He was born at Gilead, Ind. A wife and son survive him. Mr. Case joined the Hoo-Hoo on June 7, 1898, at Fargo, N. D.

The many friends of the late James Franklin

Foss (Hoo-Hoo No. 6603) paid their last respects to his memory on November 21st, when his remains were interred in St. John's cemetery, Winnipeg.

The circumstances of the death of the young man were very sad. During the early part of November he was in good spirits, and when it was found necessary to undergo an operation for appendicitis he did not consider it serious. He went to Fargo, and the operation was performed, but he died on Saturday. The deceased was the owner and manager of the Foss Lumber Company. His former home was in Minneapolis, and he came to Winnipeg three and one-half years ago. He was prominently identified with the Hoo-Hoo. Not only was the deceased a very successful lumberman but he was the youngest man in the lumber business in Winnipeg city, and one of the most popular business men in the province. The deceased is survived by his widow, who was Miss Easton, of Winnipeg.

The funeral was very largely attended and the floral offerings were many and beautiful. The pall-bearers were W. B. Tomlinson, Jay Spencer, Dan McDonald, T. Dunn, George Lister and W. E. Robinson, all friends and Hoo-Hoo.

THE ELEPHANTS AS LOGGERS.

Pall Mall Magazine, London:—The elephants round us were dragging the logs to the mill to be sawn. They were harnessed for this with a broad breastband and heavy chains. A native looped the chains around the logs, and the elephants started off with them and deposited them on the trolley. Others were picking up the sawn planks with their trunks and carrying them across the yard to be piled.

A mahout sat on the neck of every elephant, and if the animal picked up too small a plank the mahout would hint, with his iron spike, that two might go to that load. Then, grunting, the elephant would pick up the second with infinite delicacy of balance, turn, march over and deposit them beside the pile, always returning for another load so long as there were any planks ready. When there were none he would take his ease in the sun and wait. Or perhaps there were heavy logs to be pushed from one place to another, and if pushing would do, with his trunk curled against the log, no elephant would give himself the trouble of picking it up any more than a housemaid will pick up a chair on casters.

More fascinating it was than I can tell to see the jungle patriarch kneel down to a heavy log, twist his trunk around it, place it on top of the pile, and then calculate its position and push and pull until it was square in its place. The oddest, because the most reasonable thing, was to see the elephant, pushing against the end of a very heavy log, stretch out one hind leg to give himself balance and purchase. That seemed to bring him, somehow, very near to us. He was not only doing our work, but he was doing it in our way.

Presently, with one accord, all the elephants dropped work and moved in the direction of the sheds. "That means its 11 o'clock," said the foreman; "dinner hour. Not for King Edward himself could we get them to do a

stroke of work from now till 3. It's their off time. At 3 they begin again and work till dusk, and they start about 6 in the morning, but they don't understand overtime."

FORESTRY PUBLICATION.

The October number of the Canadian Forestry Journal is of special interest in view of the Canadian Forestry Convention to be held in Ottawa in January next, of which it makes announcement. The first article is a sketch of "The Montreal Forest Congress" held in Montreal in 1882. This meeting gave the impulse resulting in the establishment of the fire ranging service which has saved from destruction large areas of forest throughout Canada. "Woodland Taxation" by Dr. Judson F. Clark, Forester for the Province of Ontario, is a practical article of great value and will help materially towards a clearer understanding of the effects of such taxation and of the principles on which it should be based. Other articles are "Tree Planting in the West," by Norman M. Ross, Assistant Superintendent of Forestry for Canada; "West African Forests and Forestry," by Dr. A. Harold Unwin; "The Balsam Poplar," "Forestry in Ontario," and "Forest Fires in Ontario." Two splendid illustrations of the timber north of Prince Albert, Saskatchewan, demonstrate that the West has good forest as well as fertile fields.

EXCELSIOR BABBITT METAL.

Mr. J. R. Stratton, of Moncton, N. B., has invented a new babbitt metal called the "Excelsior," which is being placed on the market by the Excelsior Car Bush and Babbitt Company, of Moncton. The babbitt is a new composition in anti-friction metals. We understand that it is not a lead and antimony babbitt like those in common use, but contains only a very small proportion of those metals. It is about 25 per cent. lighter in weight, and it is claimed that its melting point is more than twice as high, and although it is harder, does not cut or wear the journal, while its durability is said to be from three to four times that of the babbitts in ordinary use and its anti-friction qualities are nearly perfect.

The Company advise us that the metal has been in use under test conditions in the hardest places that could be found for about two years and has given complete satisfaction and received the approval of the Shives Lumber Company and William Richards Company, Campbellton, N. B., Dominion Iron & Steel Company, Sydney, N. S., Record Foundry & Machine Company, Moncton, N. B., and other large concerns. Having demonstrated the merits and usefulness of the metal by extended test, the Company are now arranging to place it on the market, being satisfied that they have an article that will effect a large saving to users of anti-friction metals and command a ready and extended sale. The babbitt can be used in ordinary shells, but they consider that their shell filled with their babbitt will make a complete bearing more useful and economical than solid brass or any other kind of bearing. The manager of the company is Mr. R. A. Borden.

Samuel Hutton, aged 25, was killed and fearfully mangled in Cushing's saw mill at Fairville, N. B. A cast-iron wheel below the floor burst and tore up the floor. Hutton fell into the hole thus made and was mangled by rapidly-revolving parts of the broken wheel.

The Jenckes Machine Company, Limited, of Sherbrooke, Que., recently shipped to the Haskell Lumber Company, of Montebello, Que., who are building a large new saw mill, three 150 h.p. 72" diameter x 18' long high pressure tubular boilers, and a large bill of transmission machinery.

LUMBERING IN WISCONSIN AND MINNESOTA.

[By Our Travelling Representative.]

In Minneapolis, which is the lumber centre of the Northwestern States, the dealers all report having passed through a splendid season. The prices at present prevailing are fortified, they say, by the scarcity of labor and the available timber limits. Wages of men in the bush are higher, provisions are higher, and the demand being active, prices will be sustained. The retailer who did not stock up early in the year because he expected a drop in prices has seen his mistake, and 1906 is likely to be another good year.

Considerable discussion having arisen regarding the profitableness of logging by steam, the representative of the CANADA LUMBERMAN called upon several of the leading concerns operating in Minnesota and Wisconsin. The general consensus of opinion is that logging by steam can be done profitably where any other means would entail great loss.

The Backus-Brooks Company, of Minneapolis, say that where timber is remote from water and rail and so sparsely timbered that they could not afford to build a spur line or even sled it in, logging must be done by steam. An ice track or road is made by use of a snow-plow and rutter, sprinklers being sent over the road each night. The steam loggers will haul six or eight sleds, bringing in fifty thousand feet of logs each trip. Where the timber is scattered it is brought to this ice road, many settlers and farmers delivering logs to the side of this road.

Wisconsin will for many years show great timber cuts and is not nearly so badly "cut out" as many easterners seem to think. It is estimated that the Foster-Latimer mill at Mellen has a twenty-five year cut in sight, the Nash Company at Shamagolden fully fifteen or more years, the Stearns Lumber Company (who operate in the Odanah Indian Reservation), at least twelve years cut, the Edward Hines Company

about the same, and the Davis Lumber Company, at Medford, a twenty year cut. Of course, all this calculation depends upon the trade and prices. If the present good prices continue, not only Hines, but every other lumberman will cut every log he can get sawed.

It will be about ten or twelve years before all the white pine is gone from Wisconsin, so far as extensive cuts are concerned, anyway. Then the smaller mills and "Jim-crow" portables will get in their work and run probably twenty-five years longer. Wisconsin is now a big hemlock state. North of Stevens' Point there is a vast supply of hemlock and hardwoods.

Some large timber interests, are being centered on the north shore of Lake Superior, in the state of Minnesota. Alger, Smith & Company have absorbed a number of interests in Lake and Cook counties, not far from the Canadian border. This places that company practically the only loggers in that section of the country. Two Harbors, Minn., is the nearest port on the lake. Alger, Smith & Company are logging 100,000,000 feet annually on the north shore of Lake Superior, transporting it over their own road, the Duluth & Northern Minnesota, as far as Knife River, where it is transferred over the Duluth & Iron Range Railway to the company's two sawmills at Duluth. It is said that there is enough timber in the immediate territory of this road to keep the mills in operation for about five years.

The logging camps in the Ashland (Northern Wisconsin) district are hard at work. Cold weather and heavy frosts have trebled their capacity. At present there are seven large camps on the Bad River Reservation that are run all through the year, but a big increase in the crews is made as soon as snow is on the ground.

Alex. Dunbar & Sons, Woodstock, N. B., have been granted a patent for a new gang saw.

NOTES.

We understand that the Shay locomotive manufactured by the Lima Locomotive and Machine Company, for whom Messrs. W. D. Hofins & Company, of Seattle, Wash., are sales agents, has been awarded the Gold Medal Superior Jury by the authorities of the Lewis & Clark Exposition, Portland, Oregon.

Messrs. T. H. DeCew & Son have recently purchased the business of Gardner Bros. & Company at Bruce Mines, Ont. They are making considerable alterations to the mill and plant, which when completed will give them a modern establishment for the manufacture of lumber, veneers and handles on short notice.

—The Elk Lumber & Manufacturing Company, whose mill at Fernie, B. C., was destroyed by fire a short time ago, have finally decided upon rebuilding their mill on the site of the former one. It was rumored that the mill would not be re-erected at the same place, but at Hosmer. The foundation will be constructed wholly of stone right up to the saw floor and from the saw floor up the structure will be of steel.

—J. A. Tomlinson conducts a model logging camp at Okus Hollow, B.C., where sanitary buildings have been provided for the workmen. Three buildings of the portable knockdown type, manufactured by the British Columbia Mills, Timber and Trading Company, of Vancouver, have been installed. One is a bunkhouse, another a cookhouse, and the third a general utility building. Upon moving his camp from Surge Narrows to Okus Hollow recently, Mr. Tomlinson decided to put in the portable buildings, as he had come to the conclusion that for the purposes of logging-camps that class of buildings was the least expensive as well as the most desirable for other reasons. The portable buildings are put up at a greater initial cost than the common rough board type of houses, but in the long run they cost less because they may be moved from camp to camp, whereas the old style always became a dead loss when camps were moved.

THE CANADA SAW CO.

LIMITED

HEAD OFFICE
OTTAWA, ONTARIO

Manufacturers of
SAWS

of all Descriptions



WE have gained our envious reputation through our special process of tempering and the use of "Sandvik" Swedish Steel, and

"WHAT WE HAVE WE HOLD"

Nothing too small for
OUR CLOSEST ATTENTION

Send Orders to Nearest Factory



FACTORIES AT
Ottawa, Ont.
Montreal, P.Q.
Toronto, Ont.
St. John, N.B.

We Give Prompt and Careful Attention to Repair Work.

FORESTRY DEPARTMENT

CANADIAN FORESTRY CONVENTION PROGRAM.

The following program has been arranged for the forthcoming Dominion Forestry Convention at Ottawa, but is subject to alteration:

WEDNESDAY, 10TH JANUARY.

- 10 A. M.—Preliminary Business.
President's Address—The Right Honourable Sir Wilfrid Laurier.
Address by the President of the Canadian Forestry Association—Mr. E. G. Joly de Lotbiniere.
Address by Mr. Gifford Pinchot, Chief of the Forest Service of the United States.
Impromptu Addresses.
(Note.—It is proposed to invite His Excellency the Governor General to be present at this Session and address the Convention.)
- 2 P. M.—The Nation and the Forest.
"Dominion Forestry", E. Stewart, Dominion Superintendent of Forestry.
"Forest Reserves," Thos. Southworth, Director of Forestry for Ontario.
"Forest Fires," Dr. Robert Bell, Acting Director of the Geological Survey.
"Railway Motive Power and Forest Protection," Cecil B. Smith, Chairman of the Temiskaming Railway Commission.

THURSDAY, 11TH JANUARY.

- 10 A. M.—Forestry in Relation to Agriculture.
Address by Hon. Sydney Fisher, Minister of Agriculture for Canada.
"Forestry in Older Canada," C. C. James, Deputy Minister of Agriculture for Ontario.
"Forestry on the Experimental Farms," Dr. Wm. Saunders, Director of Experimental Farms.
"Forestry in the Eastern Provinces," Rev. A. E. Burke, Alberton, P. E. I.
"Forestry and Irrigation," J. S. Dennis, Director of Irrigation for the Canadian Pacific Railway.
"Tree Planting in the West," Norman M. Ross, Assistant Superintendent of Forestry for Canada.
- 2 P. M.—The Forest and the Lumber and Pulpwood Industries.
Address by Hon. W. C. Edwards, President of the Quebec Limit Holders' Association.
Paper by a representative of the Ontario Lumbermen's Association.
"The Forests of Nova Scotia," F. C. Whitman, President of the Western Nova Scotia Lumbermen's Association.
"The Lumber Industry in British Columbia," F. W. Jones, President of the Mountain Lumbermen's Association.
"The Pulpwood Industry," H. M. Price, President of the Quebec Limit Holders' Association.

FRIDAY, 12TH JANUARY.

- 10 A. M.—The Relation of our Forests to our other Industries.
"The Wood Supply of the Railways," W. F. Tye, Chief Engineer of the Canadian Pacific Railway. A Representative of the Grand Trunk Railway.
"Water Powers," C. H. Keefer, C. E.
"The Forest and the Mine," Fredk. Keffer, Manager of the British Columbia Copper Company.
"The Pulp Industry in Canada," E. B. Biggar, Editor of the Pulp and Paper Magazine.
"Newspapers and the Paper Supply," a Representative of the Canadian Press Association.
"The Manufacturers' Wood Supply," J. K. Osborne, Vice-President of the Massey Harris Co'y.
- 2 P. M.—"Forestry Education," Monsignor J. U. K. Laflamme, University of Laval.
"Municipal Forest Reserves," Dr. Judson F. Clark, Forester for the Province of Ontario.
Report of Committee on Resolutions.

An official report on forestry in the United States says forest destruction has never been so rapid as at present, that the supply of lumber has never been so near exhaustion, and that a prolonged lumber famine is impending.

The Manitoba Gypsum Co. LIMITED

MANUFACTURERS OF

HARDWALL PLASTER WOOD FIBRE PLASTER
PLASTER OF PARIS STUCCO ALABASTER
and All Kinds of Gypsum Products

The Only Plaster Co. in Western Canada

Quality of goods superior to any imported article, our mill being equipped with the latest improved machinery.

Dealers are invited to get our quotations before placing orders for Spring requirements

Office: 811 UNION BANK BUILDING, WINNIPEG

D. E. ROBERTS Lately in charge of the Plymouth Plaster Co., at Fort Dodge, Iowa.
Superintendent of Manufacture

WM. MARTIN
General Manager



An Everlasting Dado-Head

It cuts with a shear, faster and smoother than any other head
It is adjustable to the smallest fractional part of an inch.
It is indexed and can be accurately and quickly adjusted without removal from the machine.
It is EVERLASTING because any mechanic can refit it with new knives.
Its construction is plain and simple, making it easy to take care of.
It never loses its accuracy of size, its perfect shear cut, and its maximum of efficiency, no matter how long used.
You can try one for ten days and if you do not find it right in every way, return it at our expense.
Get our large circular.

C. Mattison Machine Works, Beloit, Wis.

The JOHN McDOUGALL CALEDONIAN IRON WORKS CO., Limited

MONTREAL, QUE.



Boilers, Tanks, Filters MILL MACHINERY, Etc.

Builders in Canada of the Celebrated

"WORTHINGTON" TURBINE PUMPS

AND

"DOBLE" TANGENTIAL WATER WHEELS

General Agents in Canada for the INTERNATIONAL STEAM PUMP CO. and its Companies.

Catalogues on Application

LUMBER INSURERS GENERAL AGENCY INC.

66 BROADWAY - - NEW YORK CITY

We believe that this office, offering the combined facilities of the three strongest lumber insurance organizations and having at its command the lines of several reinsurance companies, holds open to you the most practicable opportunity for transferring your entire line to companies able and willing to write at fair rates, and pay promptly in the event of loss.

These companies have more assets and more surplus in proportion to the amount of risk than any of the large general insurance companies.

Ask us to send a representative to see you, or to send blanks on which you can give a description of your risk.

LUMBER INSURANCE COMPANY

OF NEW YORK

Capital and Surplus \$300,000.

66 Broadway - - NEW YORK

TOLEDO FIRE & MARINE INSURANCE COMPANY

Capital \$100,000

SANDUSKY - - OHIO

LUMBER UNDERWRITERS

Cash Assets November 1st, \$167,484.09
Sixteen Underwriters

66 Broadway - - NEW YORK

The Lumber Insurers General Agency is in one sense like your local insurance agent. He relieves you of the burden of correspondence with a multitude of distant and scattered companies; but at the same time it gives you the benefit of the economy of dealing direct with the companies' managers.

TRADE NOTES.

Sheldon & Sheldon, manufacturers of dry kilns and heating apparatus, Galt, Ont., are building an addition to their factory.

The William Richards Company have ordered from the Robb Engineering Company two 150 horse power boilers for their mill at Campbellton, N. B.

The Robb Engineering Company, Amherst, N. S., have ordered from the Smart-Turner Machine Company, Hamilton, Ont., one of their duplex boiler feed pumps.

Cushing Brothers, Calgary, Alberta, have installed in their planing mill a duplex plunger pump, supplied by the Smart-Turner Machine Company, Limited, Hamilton, Ont.

The Westinghouse, Church, Kerr Company have placed an order with the Smart-Turner Machine Company, Limited, of Hamilton, for two of their duplex outside packed plunger pumps with pot valves to be installed in the power house of the Ottawa Electric Company, Ottawa, Ont.

The Alexander Dunbar & Sons Company, Limited, has been incorporated, with a capital of \$75,000, to acquire the foundry business carried on by Alexander Dunbar & Sons at Woodstock, N.B. The incorporators are Alexander Dunbar, senior, Alexander Dunbar, junior, Andrew Dunbar, William Dunbar and Harry Dunbar.

Application has been made for the incorporation of the James Robertson Company, Limited, of Montreal, to purchase and acquire the business carried on at St. John, N.B., and throughout the provinces of New Brunswick, Nova Scotia and Prince Edward Island by the James Robertson Company. The capital stock of the new company is \$70,000.

The Canadian Fairbanks Company, Limited, have been appointed sales agents for the John Bertram & Sons Company, of Dundas, Ont. The Bertram Company have long been known as the leading Canadian machine tool builders, and their product is well known not only in Canada but all over the world. It has reached a standard which has brought them in the front rank

of machine tool builders in any country. They have recently become identified with the Niles-Bement-Pond Company, and with the facilities offered by this company, the Canadian Fairbanks Company will be able to offer the Canadian public the very latest and best machine tool construction.

ONTARIO TIMBER REGULATIONS.

Toronto, Nov. 28th, 1905.

Editor CANADA LUMBERMAN:

Dear Sir,—At the approaching session it is hoped that the Act under which the Crown timber regulations are passed, dating now back to 1869, and the regulations themselves, will be amended. The one which gives most trouble is dated 26th March, 1895, and is as follows:

"All timber licenses are to expire on the 30th day of April next after the date thereof, but as to lots sold or located during the currency of any license the same shall immediately after sale or location be withdrawn from the operation of said license so far as timber other than pine is concerned"

It is difficult to do the absolutely fair thing as between the settler and licensee of the timber. The Province is anxious for settlers, but it must be careful not to unfairly hamper lumbering operations. I venture to suggest that while it has always been the policy of the Government to consider settlers first, it should now require evidence that the land selected is reasonably fit for cultivation. It is a notorious fact that lumbermen find the limits within their licenses "jumped", so to speak, by a man who is anxious to be bought out. On the other hand, it is well known that lumbermen hearing that a location is likely to take place, will bend their energy to stripping that particular lot. This is perhaps natural, as they have their whole outfit in the woods and the withdrawal of the lot may mean serious additional expense in their operations. What is really wanted is that no unfair advantage should be taken of the lumbermen and that no proper location should be denied to the bona fide settler. Perhaps an amendment such as follows might meet the difficulty:

"All timber licenses are to expire on the 30th day of April next after the date thereof, but as to lots sold or located during the currency of any license the same shall after notice to the licensee of said sale or location be withdrawn from the operation of said license so far as timber other than pine is concerned, provided, however, that before the selling or location the Minister of Lands and Mines shall be satisfied that the lot in question has over 50 per cent. of its acreage in lands which can be reasonably cultivated and is otherwise fit and suitable for location.

Yours truly,
FRANK E. HODGINS.

Alex. Henderson, in reporting to the Bureau of Mines on the value of agricultural lands in the Metagami district, says: "The country in general resembles the Abitibi with the exception that the large timber is smaller, both poplar and spruce. Much of the latter would average five to six inches in diameter. One variety of spruce forest was quite different from anything I had seen in former years. It was a dry spruce forest, trees four to six inches. The soil is a very hard, dry clay, with a little mould on top. This kind of forests is of considerable extent but the small timber makes it doubtful if it is of much value agriculturally. Between the Metagami and Muskego rivers is a strip of well-drained land two or three miles wide and twelve miles long. It is a good clay loam soil."

THE NEW
Dominion Saw Gummer
Saw Gummer Cutters of all Descriptions
MANUFACTURED BY
A. T. McLATCHIE, Car. inal, Ont.

C. H. VOGEL
A. M. Can. Soc. C.E.
OTTAWA, CAN. ENGINEER
Surveys, Plans, Specifications and Supervision
WATER POWER
Paper, Pulp and Sulphite Fibre Mills

PAT. OSCILLATING BOB SLED KNEE
Hauls 25 per cent. easier, and wears longer, and is lighter than all others.
THOMPSON MFG. CO., Ltd.,
Grand Bay, N. B.

MONTREAL BELTING CO.
595 St. Paul St., MONTREAL
Manufacturers
ENGLISH OAK TANNED LEATHER BELTING
Discounts 60, 10 and 5 Off Lists

FOR SALE
In guaranteed good serviceable condition, Steam Engines, Boilers Pumps and attachments, Iron and Wood Working Tools, Less freight to Niagara Falls, N. Y., or equivalent. Catalogue mailed for asking.

PAYNE MACHINERY EXCHANGE CO.
ELMIRA - - - NEW YORK

FRANK DENTON, K. C. HERBERT L. DUNN
W. MULOCK BOULTBEE.

DENTON, DUNN & BOULTBEE
Barristers, Solicitors, Notaries, etc.
National Trust Chambers. TORONTO

WANTED

Millwrights and Mechanics capable of appreciating superior mechanism in saw mills and wood working machinery to send for a 144 page catalogue of up-to-date line of saw mill, gang edger, lumber trimmer, planing mill and shingle mill machinery manufactured by
DELOACH MILL MFG. CO.,
P. O. Box 509,
Atlanta, Ga.

SANDFORD FURNITURE AND WOODENWARE, LIMITED
FENELON FALLS, ONTARIO
PLANING and MATCHING in Transit
Dealers in all kinds of NATIVE HARDWOODS, Kiln Dried Flooring Siding and Mouldings.

Car Lot Prices on Application.

DO NOT

underestimate the importance of checking your figures when ascertaining contents of cut material in 4/4, 5/4, 6/4 or 8/4 lumber, or surface measure for veneers, etc., for boxes, mill work, furniture, etc. Save time, labor, brainwork, and prevents errors by using the comprehensive, successful and highly recommended "Box Estimator" which gives results, decimally expressed, at a glance.

Sent on Trial.

J. M. LEAVER,
Sault Ste. Marie, Mich.

A COMPLETE FACTORY
FOR \$650

- ! Concrete Stone Making Machine.
- ! Concrete Brick Making Machine.
- ! Power Concrete Mixer.
- ! 5 H. P. Gasoline Engine.
- ! Window Cap and Sill Mould.
- ! Set of Sidewalk Tools.

This is the most complete outfit made for the manufacture of concrete building material. Get ready for the spring trade. \$650 invested in this outfit will bring larger returns than \$3,000 in a Mercantile Business or \$6,000 invested in a farm. We shall be pleased to send you our catalogues and printed matter.

NORTHWESTERN STEEL AND IRON WORKS
EAU CLAIRE - - - WISCONSIN

"SANFORD" LOGGING TOOLS

Have been for 50 years

"THE STANDARD" FOR LUMBERMEN

OUR MOTTO: Quality, not Quantity.
The Best is the Cheapest.



We make a Specialty of

LABOR SAVING TOOLS FOR LUMBERMEN

"SANFORD TOOLS" are guaranteed to please

Send for our "Illustrated Catalogue" and let us quote you—We can interest you

A. SANFORD LOGGING TOOL CO.,
OSHKOSH, WISCONSIN, U.S.A.

"Rush Orders a Special Delight."

PUBLICATIONS.

The November number of *For California*, published by the California Promotion Committee, is devoted to the forest and lumbering industry of the state of California. United States Forester Gifford Pinchot, than whom there is no greater authority on the timber interests of the country, contributes an article on the objects of forest reserves, and shows the great good that is done to the state by the United States government by means of the national forest reserves. Following in the same line is an article by E. T. Allen, State Forester, who talks of the combination of interests of private owners and the state. Clarence E. Edwards has an article on "The Pine Industry," and George O. Brehm tells of the use of eucalyptus as a hardwood. The pioneer lumberman, E. C. Williams,

gives an interesting article on redwood and J. F. Nash tells of scientific lumbering in contradistinction to the old style of cutting the forests.

"Edgers" is the title of the latest catalogue published by the William Hamilton Manufacturing Company. It refers to their many types of edgers, including the "Garland," "Star," and "Pacific Coast" and the "Kendall" patent variable gang circular.

NEW ROUTE TO SOUTHERN CALIFORNIA.

The opening to traffic of the San Pedro, Los Angeles and Salt Lake Railroad, known as the Salt Lake Route, between Salt Lake City and Los Angeles, makes available a most desirable short line to Southern California. This will doubtless be of great interest to the ever-increasing number of people who journey each winter to this sunny clime.

In anticipation of a large volume of this class of traffic, a handsome equipment of modern vestibuled trains has been placed in service in connection with the Overland Limited train of the Chicago, Union Pacific and North Western Line, the most luxurious train in the world. This forms a new and interesting route by which first class tourist travel can reach the sunshine and flowers of Southern California, travelling on fast schedules and in luxurious comfort. Rates, folders and full information can be obtained from B. H. Bennett, General Agent, 2 East King St., Toronto, Ont.

P. PAYETTE & CO.

Manufacturers of Saw Mill and Engine Machinery, and all kinds of Marine Machinery.
PENETANGHISHENE, ONT

TRANSMISSION ROPE

We are the largest Manufacturers of **TRANSMISSION ROPE** in Canada. Our mills are equipped with special machinery for manufacturing extra long lengths. We import the most select Brands of Manila Fibre, and are therefore in a position to supply a **FIRST CLASS ROPE**.

Rope Transmission has proved to be the most satisfactory and economical drive.

If you contemplate buying, we would be pleased to have our expert call upon you.

CONSUMERS CORDAGE CO., LIMITED
Montreal and Halifax

Three Complete Saw Mills

To be Sold at Manufacturers' Prices

TO CLEAR OUT A STOCK

These Mills are of the Lane Pattern, perfectly new, with capacity of 10 to 15 thousand per day. We have also for sale one **Saw Trimmer**, one **Lockport Shingle Mill** and one **Double Edger**.



The Manitoba Iron Works Co.
LIMITED

Logan Avenue West, WINNIPEG

THE LUMBER MUTUAL FIRE INSURANCE COMPANY
BOSTON, MASS.

STRENGTH

ECONOMY

NET ASSETS, OCTOBER 31, 1905
All Liabilities Deducted—Sec. 1—Chap. 188—Mass. Laws.

DIVIDENDS TO POLICY HOLDERS

\$721,712.50

33 ¹/₃ %

MAIL EXPIRING POLICIES WITH YOUR ORDER.

MORE ABOUT LARCH.

Architects and builders are now recognizing the utility of the western or mountain larch for interior finish. It is very similar, although considered by experts to be much better, than the famous American or Idaho larch. Speaking of the latter, Mr. E. T. Chaplin, the well known lumber expert, said:—"Larch lumber is of a reddish color, resembling fir in grain and quality. It is as hard as fir, but carpenters claim it does not split as easily. It is a better lasting wood when exposed to the weather

than the Coast fir. It has very little tendency to warp when exposed, although it is hard to dry and avoid season check. It takes a very beautiful polish and for inside finish is an ideal wood. However, it is difficult to furnish this material absolutely free from defects, such as season checks, etc."

The larch found around Cranbrook and Ryan, B.C., is a particularly fine grade and when worked up into interior finish is very beautiful. It is also adapted for the manufacture of railway cars. Many carpenters do

not like to use it because after a nail is driven into it, it is very hard to pull it out, but this is one of its recommendations.

Do not hide your light under a bushel. Tell others of what you have accomplished in the direction of the economical production of lumber.

W. S. Dwindelle, a prominent resident of Minneapolis, has been in British Columbia recently looking into the lumber industry. He is said to be favorably impressed with the idea of building a saw mill on the Fraser river at New Westminster, which mill would utilize the timber cut by the Fraser River Tannery Company, in which he is a large shareholder.

OSBORNE & CLARK

WHOLESALE

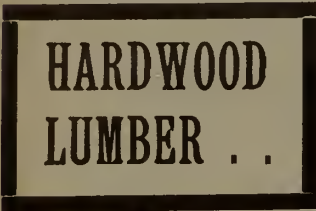

MAPLE AND OAK FLOORING

300 Lumber Exchange,
MINNEAPOLIS, MINN.



Quick, reliable, durable, adjustable, easy to work. There's the story of

The Portland Picket Pointer

in a nutshell. A really perfect pointer; costs but little. Write for descriptive booklet.

Yours for true measuring,

The Portland Lineal Meter

Is 'true to the inch' on moulding, flooring, sheathing, etc., does away with over-runs and so soon pays for itself. The acknowledged "best yet." Write for booklet.



ADDE & CO.,
109 Kennebec St. - PORTLAND, ME.



RESAWING MACHINE

This machine has been designed to meet the demand of mill owners for a powerful machine. In this machine the frame is cast in one piece. All the legs are of cast iron and those under the saw table are cast in one piece with it.

The rolls are of large size and driven by still larger gears cut from the solid. This gives a powerful drive. The machine, as can be seen from the engraving, is provided with a steam press and there is a very convenient gauging mechanism for the stationary roll, not shown in the cut.

The most up to date resawing machine made.

THE SAVOIE-GUAY COMPANY
Makers of Saw Mill Machinery,
PLESSISVILLE STATION, P. Q.

USE

"MIDLAND" BABBITT METAL

IN YOUR BEARINGS

 **None Better**

GEORGIAN BAY ENGINEERING WORKS
MIDLAND, ONT.

PAROID ROOFING

"The Roofing of Quality"

EVERY lumber dealer in Canada can make with Paroid one of their best paying side lines, and our advertising campaign on Paroid is bound to bring you new customers for your other lines. Thousands of lumber dealers all over the United States handle Paroid. There is a reason for it. Write for our dealer's proposition and see for yourself.

F. W. BIRD & SON, Makers
Established in U. S. A. in 1817

Canadian Factory and Office: Hamilton, Ont.

LUMBERMEN'S LOG STAMPS
 STEEL & RUBBER STAMPS, BRASS STENCILS, ETC.
THE SUPERIOR MFG. CO.
 COR. BAY & ADELAIDE STS. TORONTO, CAN.
 Write for Catalogue.

JNO. S. FIELDING, C. E.

WATER POWERS AND DAMS

Room 2, 15 Toronto Street - TORONTO

WIRE ROPE

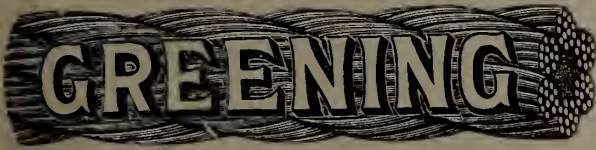

"ACME" Brand

Highest grade of hoisting rope made. Extra tensile strength for heavy work. One strand painted green, look for it.

Use Greening's Rope Grease for Lubrication

THE B. GREENING WIRE COMPANY, LIMITED

HAMILTON, ONT.

MONTREAL, QUE

Galt Machine Knife Works



MACHINE KNIVES OF EVERY DESCRIPTION

FOR **Woodworking Machines**

... Send for Price List ...

The Peter Hay Knife Co., Limited - Galt, Ont.

1,000 Mershon Band Resaws

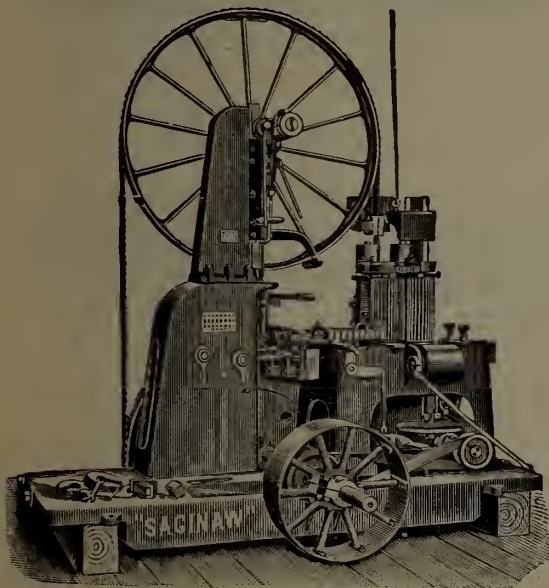

IN DAILY USE



BUY DIRECT AND GET

— THE —

GENUINE



W. B. MERSHON & CO.

Saginaw

Mich, — U. S. A.

FIRE

\$250,000, full paid, is the basis of every Policy issued by the

NATIONAL LUMBER INSURANCE CO.
of BUFFALO, N. Y.

Stock Policy. N. Y. State Laws.

No assessment; no objectional feature

Instruct your Agent to Write to Us

THE WEST!!

Golden Opportunities
for Wooden Ware Factories

"The Trades & Industries Committee, composed of members of City Council and Board of Trade, believe there is a good opening for Furniture and Wooden Ware Factories in Vancouver, B.C.

Parties interested and wishing for information, write—

THE SECRETARY."

HUTHER BROS. PATENT GROOVER OR DADO HEAD
For cutting any width groove from 1/4-inch to 2 inches or over

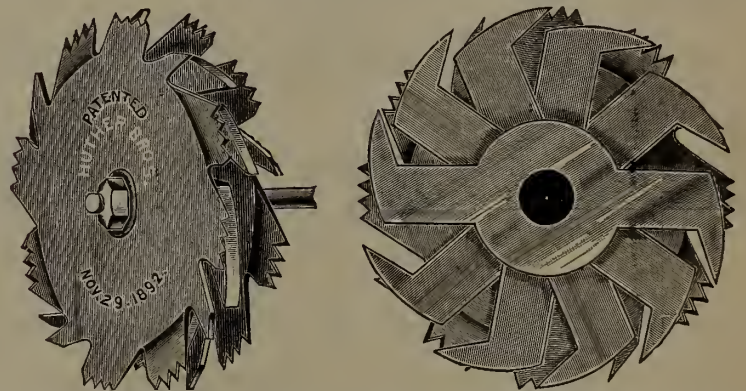

Can be used on any Circular Saw Mandrel. Will cut a perfect groove with or across the grain. This is the only Dado Head on the market that gives entire satisfaction on all classes of work. No screw adjustment. For different width grooves, simply remove or add inside cutters. Sold by builders and dealers of woodworking machinery in all parts of the United States. Will send on approval, in competition with any other make on the market; if not the best return at our expense. HUTHER BROS., Platt Street, ROCHESTER, N.Y., manufacturers of Circular Saws, Morgan Pattern Lock-Corner Box Cutters, Concave Saws, etc.

Special to Lumbermen, Miners and Railway Contractors



We are Manufacturers of:—Mince Meat, Baking Powder, Coffee, Spices, Flavoring Extracts, Mustards, Tomato Catsup, Worcestershire Sauce, Jams, etc., and all kinds of Grocers' Sundries for Camp Use. Also Sauer Kraut, Pickles and Sausage Meat.

Mince Meat put up in 75 Pound Tubs.	1/2 Barrels about 300 Pounds.
	Barrels about 600 Pounds.
Sauer Kraut and Pickles in Barrels.	Sausage Meat in 50 Pound Tins.
	Sauce and Catsup in 5 Gallon Pails.

ALL GOODS GUARANTEED

Special Attention Given to Mail Orders



The Capstan Manufacturing Co., TORONTO, ONT., CAN.

THE DYMENT FOUNDRY COMPANY

BARRIE, ONTARIO

Manufacturers of

Engines, Boilers Steam Feeds . . .

AND A COMPLETE LINE OF

Saw, Shingle and Lath Mill Machinery

Can ship mills in a week's notice. Write us for prices and Catalogue.

Internal Friction - Double Geared
Solid Iron Frame Log Jack

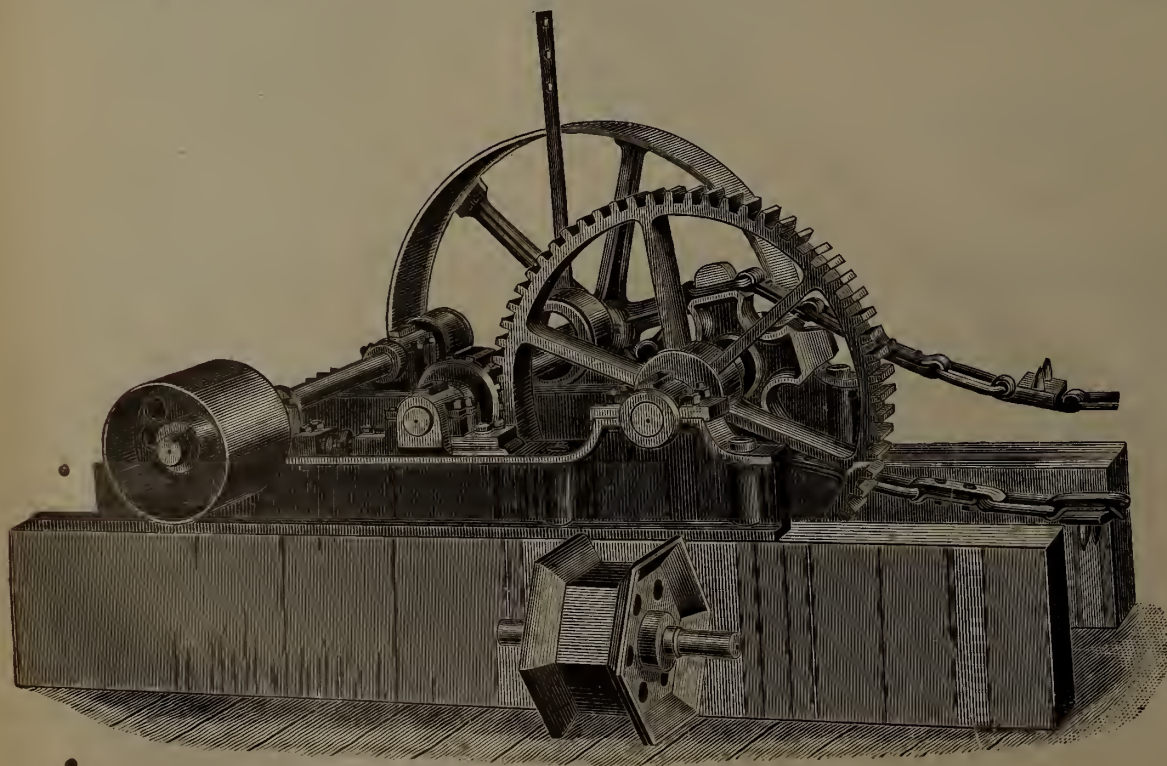

o ——— o

The strongest and easiest running machine made for the purpose. The frame is one solid casting. The shafts are all steel, and of ample size. Boxes are adjustable for wear. Any kind of sprocket or chain wheel will be furnished to fit any size or style of chain.

This machine may be placed on mill floor or on timbers below mill floor, whichever is most convenient.

Correspondence Solicited

Catalogues of saw mill, shingle mill and lath mill machinery on request.

o ——— o

F. J. DRAKE - - Belleville, ONT.



SCRIBNER'S LUMBER AND LOG BOOK

Price 35 Cents.

The CANADA LUMBERMAN, TORONTO

LUMBERMEN

— SHOULD SEE OUR —

PATENT SEAMLESS HEEL LARRIGANS

No chance to rip where it generally does rip in the ordinary make. Also our

PATENT LEGGING

The only legging where the bell front is held down close to the foot so that it can't turn up

— BOTH MANUFACTURED BY —

THE R. M. BEAL LEATHER CO. LIMITED.
LINDSAY, ONT.
Write Us

Dundas Lumberman



A New Axe tempered by a new process which enables us to submit to any lumberman three or more samples of Axes, all different degrees of hardness, and on a selection being made we will guarantee to furnish any number all exactly the same temper as sample chosen.

THE DUNDAS AXE WORKS
Dundas, Ont.

NEW SEASON'S CURING

LONG CLEAR BACON

SHORT CUT PORK - SAUSAGE, MEATS, &c.

High Grade Quality
Write us for Quotations

THE PARK BLACKWELL CO., LTD.
PORK AND BEEF PACKERS
TORONTO

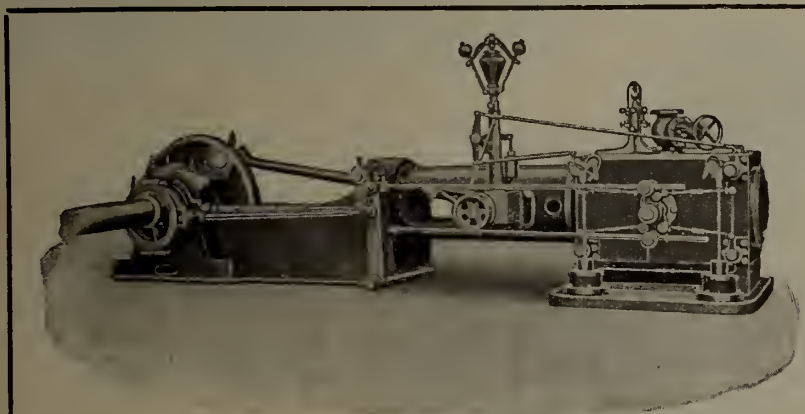

Jenckes-Corliss Engine, Tange Frame, Double Eccentric, Size 18" x 42".

Corliss Engines

The Jenckes-Corliss is built in all sizes for every service; in Simple and Compound Styles with the usual modifications. Write for Illustrated Bulletin.

The Jenckes Machine Co., Limited
48 Lansdowne Street - Sherbrooke, Que.

Rodgers Iron Mfg. Co.
MUSKEGON, MICH.

Write to us and we will tell you all about it. Read what they say—hundreds more like them.

Tomahawk, Wis., March 3, 1905.

Rodgers Iron Mfg. Co.
Muskegon, Mich.

Gentlemen:

Your favor of February 24th is received; as we have just ordered another of your 72 inch Combination Edgers with inch and two inch gangs on them, should think this would be conclusive evidence of our satisfaction with your machines, as we already have three of them in operation.

Yours truly,

~ ~ ~

West Monroe, La., Oct. 13, 1904.

Rodgers Iron Mfg. Co.,
Muskegon, Michigan.

Gentlemen:

We beg to hand you herewith, check to cover one edger and fixtures as per your invoice of July 15th.

We are very well pleased with the machine and the work it is doing.

Yours truly,

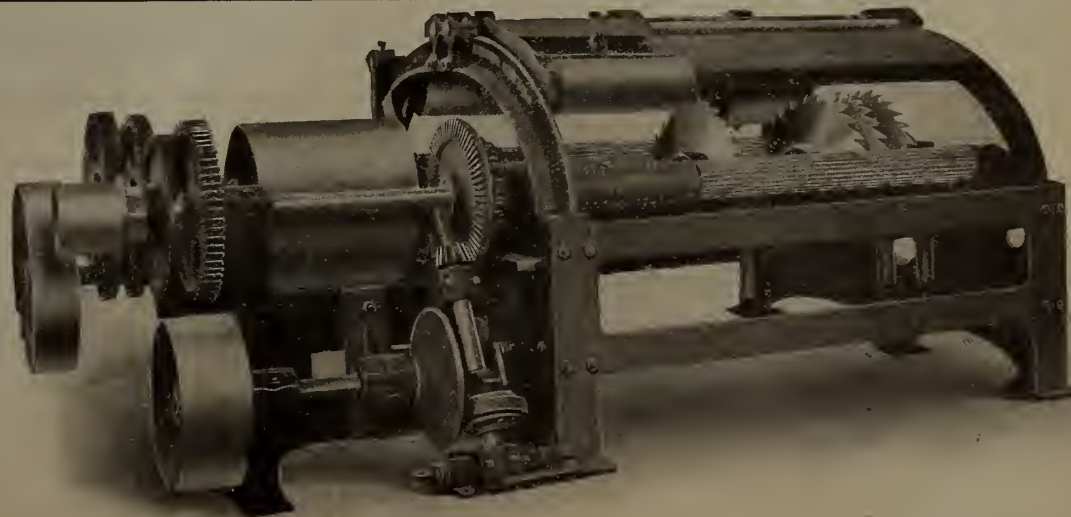

COMBINATION GANG EDGER WITH RIFT FLOORING ATTACHMENT

P. H. WRIGHT
 43 Bank Street, OTTAWA
Lumbermen's Agent
 All kinds of Mill and Bush
 help secured on short notice
 Telephone 2586

H. J. FRIEL
 EMPLOYMENT AND LUMBERMEN'S AGENT
 Bushmen supplied on short notice, also
 mill hands. Hotel help of all kinds procured.
 Office: 73 BANK STREET
 Phone 721 - - - OTTAWA

OILS

Manufacturers High-grade Cylinder, Machine and Sawmill Oils.

Calypsol Grease

for Sawmill Purposes a Specialty. Our products are made from finest Pennsylvania stocks.

We solicit your correspondence.

St. John St.,
 MONTREAL. **Commercial**
 Offices and Works: **Oil Co.,**
 Manchester, Eng. **Hamilton, Ont.**
 Hamburg, Germany.
 Newark, N. J.
 Chicago, Ill.



WATEROUS, BRANTFORD, CANADA

Sole Canadian Agents - Prices Reduced



Ever
 seen
 one
 of
 these
 powerful

McCiffert Log Loaders

at work, loading or skidding logs, or maybe, switching its own empties? If you haven't you can't fully appreciate the immense amount of heavy work it can do—and at such a saving. It is really wonderful.

Send for catalogue, also booklet of facsimile testimonial letters.

Clyde Iron Works
 Duluth, Minnesota, U.S.A.

THE E. L. PURVIS CO.,
 18 COLBORNE ST., TORONTO, ONT.



PIPE AND BOILER COVERINGS

Asbestos Mineral Wool and all kinds of Fireproofing

Material. Agents for

FAMOUS MICA COVERINGS

MAPLE LEAF
STITCHED COTTON DUCK
BELTING
DOMINION BELTING CO. LTD.
HAMILTON CANADA

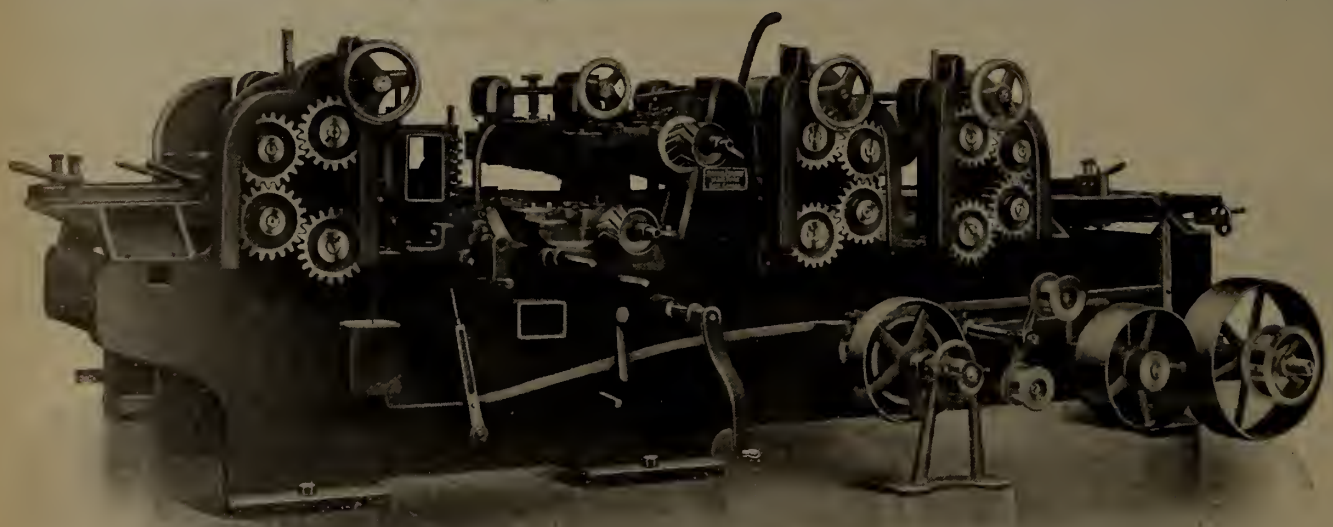

PLANER AND MATCHER

M 169

Made in several sizes; all fitted with wedge platen for instantly adjusting, regulating and distributing the cut between the cylinders; the greatest labor saver embodied in planing mill machinery. We manufacture a full line of wood working machinery. Write for prices and particulars.

COWAN & COMPANY
 OF GALT, LIMITED
 GALT, - CANADA

ATKINS ALWAYS AHEAD!

DEFINITE IDEAS



QUALITY IS THE THING!

are suggested to mill men by the words Atkins and Silver Steel. You know that Atkins stands for honesty and thoroughness in workmanship and the most careful supervision of every detail of saw making. And Silver Steel stands for the most perfect material that ever went into a saw.

"The Proof of the Pudding is in the Eating"—An impartial trial will establish the fact that our Saws will cut 25% more lumber at less expense of time and labor than any others.

Write us for our Sawyer's Hand Book.
 General Sales Agents for Covel's Filing Room Machinery.

E. C. ATKINS & CO., Inc.,

Leading Manufacturers of Circular, Band, Cross-Cut, Hand and Wood Saws, Etc.

Factories and Home Office,
 Indianapolis, Ind. U.S.A.

Canadian Branch,
 56 King St East, Toronto, Ont.

WARNOCK TOOLS

Best in the World



If Strength, Durability, Correct Construction and Lightness are an object, we have the article you are looking for.

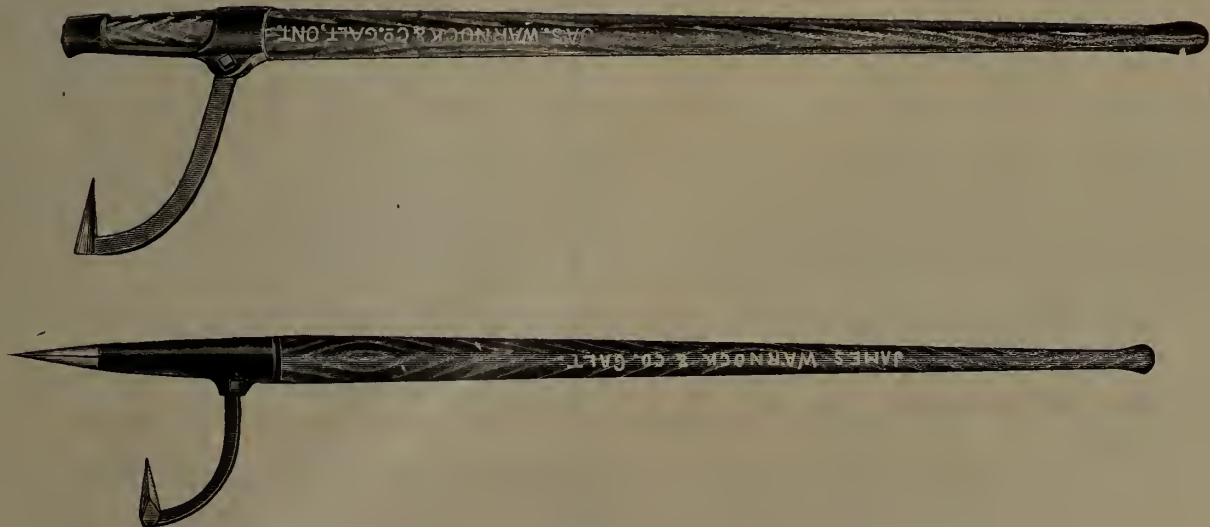

THE JAMES WARNOCK CO., LIMITED

GALT, ONT.

Cross-Grained and Knotty Lumber
IS WELL FINISHED WITH

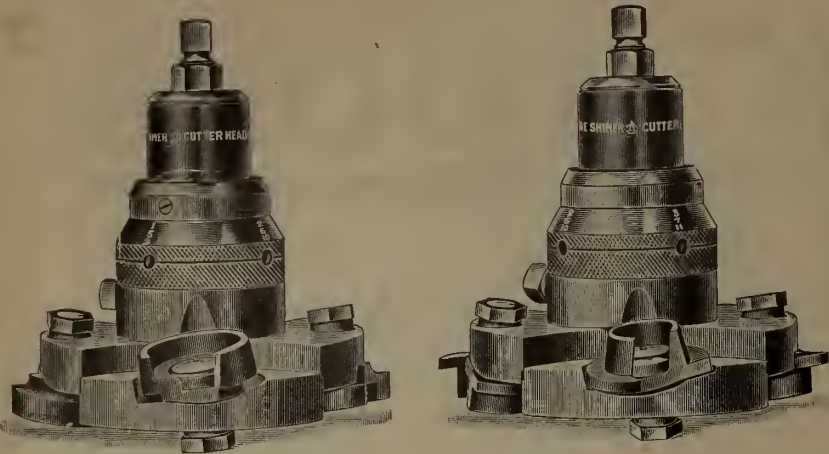

The Shimer Cutter Head

It reduces the number of culls as no other Head can.

The Cutters work alternately with side clearance; ply their way through the worst lumber that you may find for high grade finish.

The bit seats and their bit and bolt combinations supply the make-ready for every emergency.

For tight and loose fitting of tongue and groove joint, a single turn of the expansion ring will suffice, with automatic stop and lock.

NOTHING { **COMPLICATED**
TO GET OUT OF ORDER

The Shimer Cutter Head is made to fit any make of matcher or moulder. You take the measurements—we do the rest, and guarantee to fit your spindles. Address

SAMUEL J. SHIMER AND SONS
Milton, Pennsylvania

RUBBER BELTING

For
Transmitting
Elevating
and
Conveying



Rubber
Hose
for
Water
Steam
Air
Suction
Fire
Protection

THE GUTTA PERCHA & RUBBER MFG. CO.
OF TORONTO, LIMITED.

HEAD OFFICES: 47 YONGE STREET, TORONTO, CAN.
Branches: Montreal, Winnipeg, Vancouver.

STEAM NIGGER

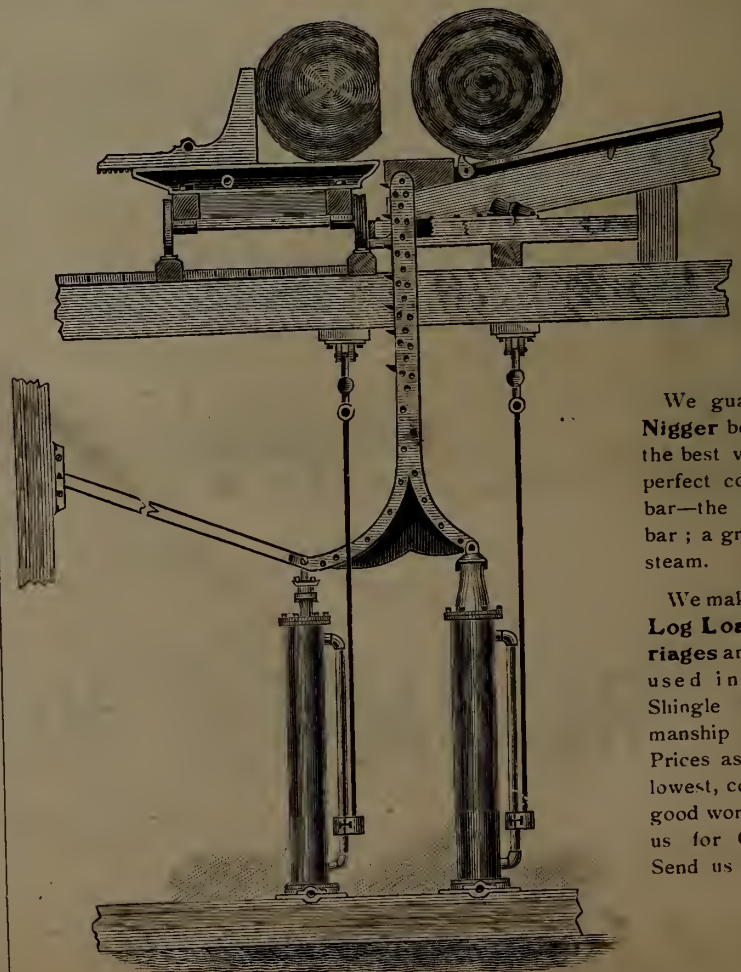

We guarantee this Nigger because it has the best valve made; perfect control of the bar—the best type of bar; a great saver of steam.

We make Kickers, Log Loaders, Carriages and everything used in a Saw or Shingle Mill. Workmanship guaranteed. Prices as low as the lowest, consistent with good work. Write to us for Catalogue. Send us your orders.

B. R. MOWRY & SONS,
GRAVENHURST, ONT.

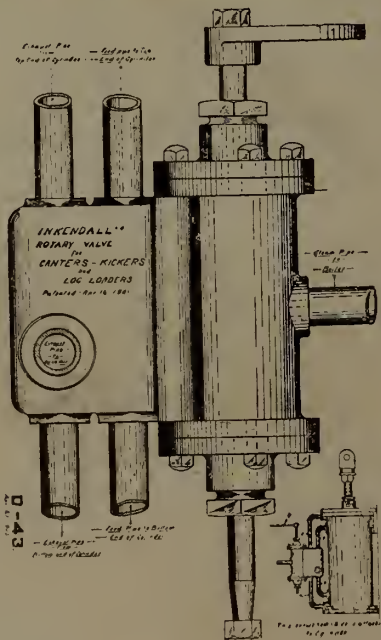

The Kendall Rotary Valve for Canters

KICKERS, LOG LOADERS AND JUMP-UP SAWS

Can be attached to any Canter or Kicker now in use. It won't leak steam but it will cushion the piston at either end of the cylinder without fail. Many of these valves have been in use for the past four years without having any repairs or attention paid to them. They are cheap in price too.

I. N. KENDALL, 203 Bridge St.
OTTAWA

SHERMAN'S FLOORING MACHINES PATENTED

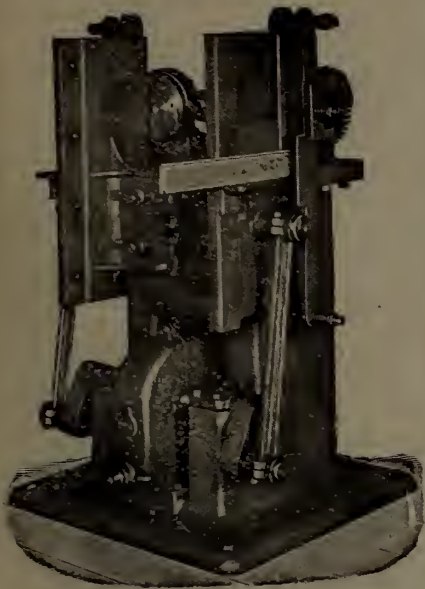

Above cut shows our End Matcher, the best machine in the market for end matching flooring strips. They do rapid and accurate work, and are durable—therefore used by leading flooring manufacturers. Make your flooring profitable by end matching it.

We Make the **SHERMAN SIDE BORING MACHINES** and the **SHERMAN FACE BORING MACHINES**

To bore flooring while it is being run on the flooring machine. Write for circular and list of users.

W. S. SHERMAN CO.
1150 Holton St., Milwaukee, Wis.

Reliable Veterinary Remedies

No logging outfit is complete without a supply of reliable veterinary remedies. Getting the wrong kind means the loss of the use of your horses when time is valuable.

Johnson's Veterinary Remedies are guaranteed never to fail when used as directed. You get your money back if they ever do.

They are
Johnson's Horse Liniment No. 1.
A penetrating Alcoholic Liniment. Put up in one gallon jugs, with full directions, per imperial gal. \$4.50

Johnson's Horse Liniment No. 2.
A combination of the best oils used as liniments, imp. gallon . \$3.00

Johnson's Horse Colic Remedy.
A sure and speedy cure for colic. Imperial gallon \$5.00

Johnson's Veterinary Healing Ointment.
Positively the best all-round healing ointment made. In use by the largest owners of horse flesh in Canada. Put up in 2 lb tins, each . . \$2.00 or in 1/4 lb tins, per dozen . . \$3.00

Johnson's Condition Powders. (Concentrated). Put up in bulk, per lb. . . . 3c.

These goods being put up in bulk are more economical than others, as cost of bottling, etc., is saved.

CAMP REMEDIES.
In addition to our Veterinary Remedies we make a line of medicines for lumbermen, including a strong, penetrating liniment, healing ointment, cholera cure, liver pills, coughsyrup, in fact anything in the form of Camp Drug Supplies. We know that there are no better remedies made than those we offer. There may be others nearly as good, but they lack our guarantee. Satisfaction or money back. A trade discount of 10% allowed off all orders amounting to \$100.

Send postal for printed matter.

A. H. JOHNSON
Wholesale Druggist
Collingwood, Ont.



STEAM

Are your present boilers capable of generating steam PART of the time but not ALL of the time?

Would you like to obtain EVERY OUNCE of steam your boilers are capable of making EVERY MOMENT in the day?

Would you like to do it with sawdust alone?

GORDON HOLLOW BLAST GRATE

will enable you to do it.

Sold on approval, and returnable at our expense if unsatisfactory.

The GORDON HOLLOW BLAST GRATE CO.



The Largest Manufacturer of Blast Grates, Edgers and Trimmers in the World

GREENVILLE, MICH.

A FINE STEAM PLANT

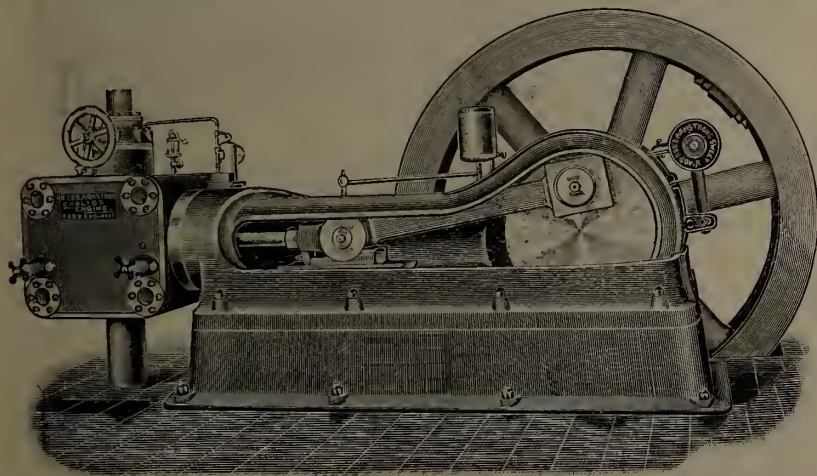

'I will say without qualification, at it is as fine a boiler and engine plant as size. I have ever had the pleasure of seeing for. The engine was working without heating and absolutely without any noise. I wish to congratulate you on your success in building this class of engine and hope that we may have pleasure in dealing with you again.'

The above refers to a 350 horse power Robb-Armstrong Corliss engine and two 175 horse power Robb-Mumford boilers installed by us.

ROBB ENGINEERING CO., Ltd.
AMHERST, N.S.

AGENTS: WILLIAM McKAY, 320 Ossington Avenue, Toronto. WATSON JACK & COMPANY, Bell Telephone Bldg Montreal. J. F. PORTER, 355 Carlton St., Winnipeg.

SAW MILL FOR SALE VERY CHEAP



New, perfectly equipped, improved band saw mill plant (including buildings) located on both rail and tide-water, that can be easily taken down, shipped and set up. The buildings were designed, and the machinery bought, set up and arranged by an acknowledged expert, so as to produce the most work at the least cost.

If you want to save the bother, loss of time, worry and fuss incident to creating and equipping the most profitable band saw mill plant and save about half the cost, here is your opportunity! But you must act now! Procrastination is the thief of profits. Address

Saw Mill "F" Box 775, New York, N. Y.

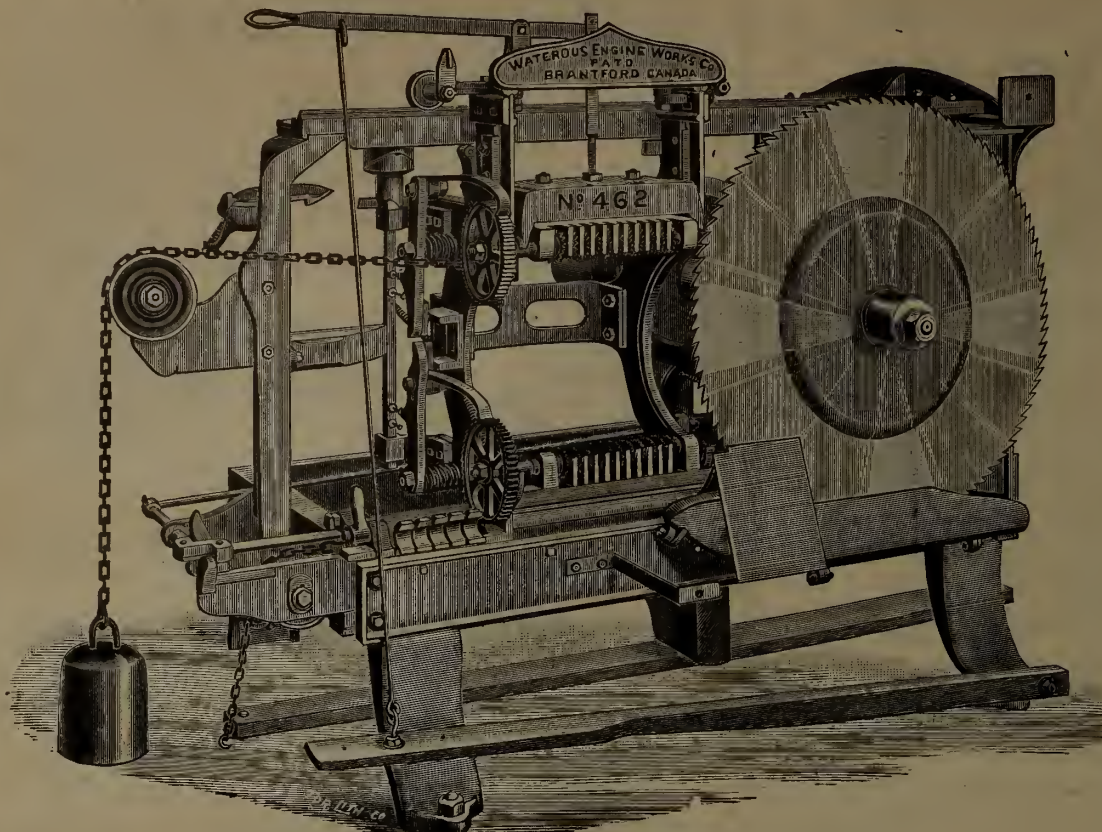

WATEROUS SELF-FEED SHINGLE MACHINE
(BUILT IN FIVE SIZES)

Leaves but 7/8 in
waste on spalt
when desired.

This machine is
the result of many
years experience
in this line.

THE IMPROVED "DIXIE"
SELF-FEED SHINGLE MACHINE

Patented in United States and Canada

ROLLER BEARING CARRIAGE
AUTOMATIC TILT
QUICK DROP TABLE



(BUILT IN FOUR SIZES)

Send for Circular giving full particulars
of these machines, and prices.

WATEROUS ENGINE WORKS CO.
BRANTFORD, CAN.



Experimenting with Dry Kilns is an Expensive Luxury

Why keep on using a Kiln that has to be regulated with dampers, chimneys and complicated fans. Put in a Morton Automatic Moist Air Kiln and your Dry Kiln troubles will be ended. We do not sell a man a Dry Kiln to dry Mahogany and then tell him it will dry Basswood staves. Our thirty years experience in the Dry Kiln business yours for the asking.

Write to-day for Illustrated Catalogue "C"

The A. H. Andrews Co.

174-176 Wbash Avenue - - CHICAGO, U.S.A.

Eby Machinery Co., Western Agents, 17-19 Main St., San Francisco, Cal.

WHY BUY "STANDARD" DRY KILN TRUCKS?

Because they are BETTER—better in materials, better in construction—run more easily, give more satisfactory service and have a longer life of usefulness than any other dry kiln truck on the market.

These statements we PROVE in our printed matter by a detailed description of every part of "The Standard" Trucks.



If you are having truck troubles tell us to send you our Catalogue "D" and the booklet "Truck Truths". Then compare your present trucks with "The Standard".

THE STANDARD DRY KILN CO'Y INDIANAPOLIS, IND.



PLANING MILL EXHAUSTERS

Piping—Furnace Feeders

Cyclone Dust Collectors

Systems Installed Complete

— ALSO —

Natural Draft and Blower Dry Kiln Apparatus

Trucks, Cars, Etc.

Hot Blast Heating Systems

— Write for Catalogues —

SHELDON & SHELDON

Engineers and Manufacturers
GALT, ONTARIO



FOR _____

DRY KILNS

that will season lumber of all kinds and under all conditions, whether partially air-seasoned or green from the log, in shortest time and at least cost, entirely free from checking, warping or case hardening,

Write to—

MC EACHREN HEATING & VENTILATING COMPANY, GALT, CANADA



McFARLANE'S BOSS LUMBERING TOOLS

On our "BOSS" PEAVEYS and CANT HOOKS we use only FORGED STEEL SOCKETS. They are the LIGHTEST and STRONGEST on the MARKET. They are all fitted with air dried SPLIT ROCK MAPLE HANDLES, and shipped to every lumbering point in CANADA.

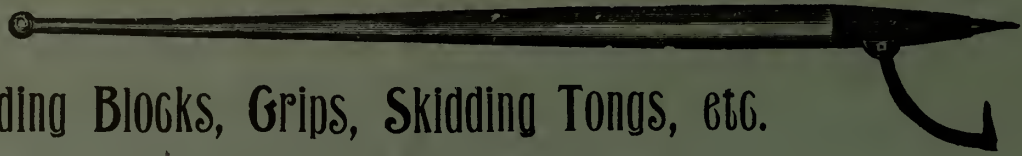

Steel Yarding Blocks, Grips, Skidding Tongs, etc.

WRITE FOR QUOTATIONS

THE McFARLANE-NEILL MFG. CO., LIMITED, ST. MARY'S, YORK CO., N. B.

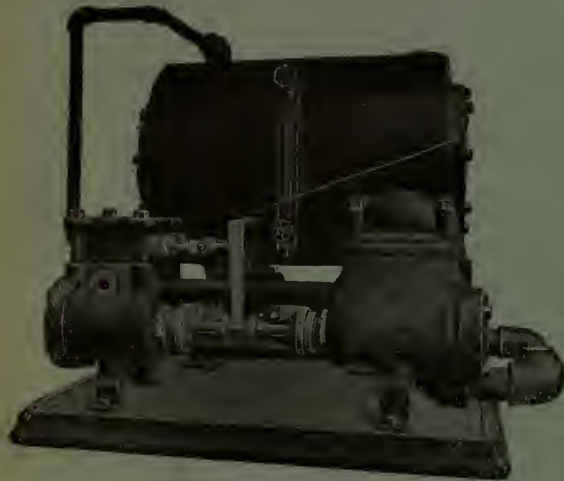

AUTOMATIC
FEED PUMP AND
RECEIVER

STEAM and POWER
PUMPS

ENGINES
BOILER

THE
SMART TURNER
MACHINE COMPANY
Limited.
Hamilton - Ontario

Uncle Sam would not allow his battleships to be babbitted with inferior babbitt metal. New Battleship "Nebraska" is lined with Syracuse Babbitt. Always specify best. It is cheapest in the long run.

SYRACUSE SMELTING WORKS

MONTREAL NEW YORK SEATTLE

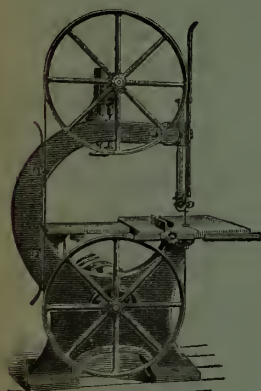

CRESCENT MACHINERY

Quality is all right.
So's the price.

Band Saws
Jointers
Saw Tables

Very low price on
BAND SAW BLADES
Catalogue tells the rest.

H. W. PETRIE
Dept. C. M.
TORONTO, ONT.



THE
LEATHER
BELT
THAT'S
KNOWN
OUR
"EXTRA"

MONTREAL TORONTO
WINNIPEG VANCOUVER

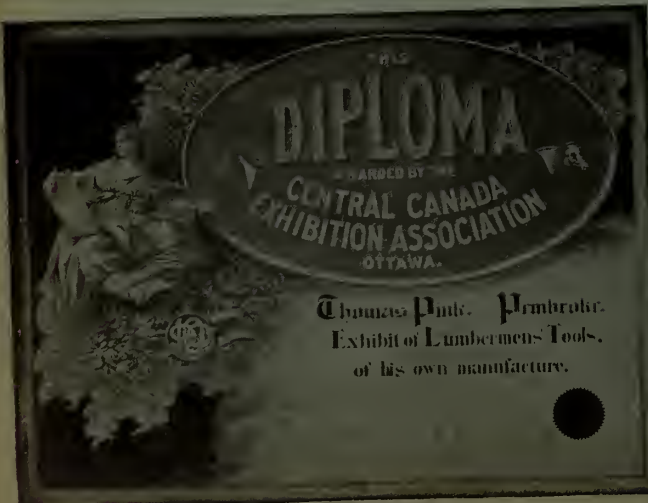

THOMAS PINK
Pembroke, Ont.

PINK LUMBERING TOOLS

The Standard Tools

In Every Province of the Dominion, * * * * *
* * * * * New Zealand, Australia, Etc.



Pink Round Bill Peavey, Handles in Split Maple

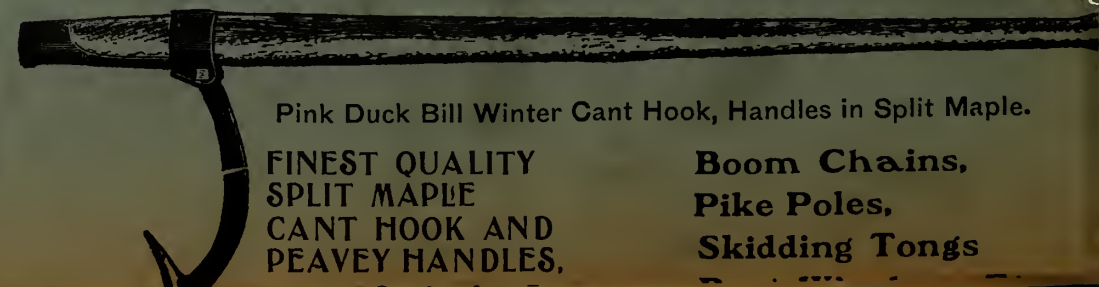

Pink Duck Bill Winter Cant Hook, Handles in Split Maple.

FINEST QUALITY
SPLIT MAPLE
CANT HOOK AND
PEAVEY HANDLES.

Boom Chains,
Pike Poles,
Skidding Tongs